



Addis Ababa University
Addis Ababa Institute of Technology
School of Electrical and Computer Engineering
Telecommunication Engineering Graduate Program

Coverage, Capacity and Cost Performance Analysis
of 5G Sub-band(3.5GHz) and 5G
Millimeter-wave(26GHz): In the Context of Addis
Ababa, Ethiopia

By:

Tamerat Kebebew

Advisor:

Beneyam Berehanu(PhD)

A Thesis Submitted to the School of Electrical and Computer Engineering Graduate Studies
in Partial Fulfillment of the Requirements for the Degree of Master of Science in
Telecom Network Engineering

August 2023

Addis Ababa, Ethiopia



Addis Ababa Institute of Technology
School of Electrical and Computer Engineering
Telecommunication Engineering Graduate Program

Thesis Title

**Coverage, Capacity and Cost Performance Analysis of 5G
Sub-band(3.5GHz) and 5G Millimeter-wave(26GHz): In the
Context of Addis Ababa, Ethiopia**

By:

Tamerat Kebebew

Members of the examining committee's names and signatures:

Beneyam Berehanu(PhD)

Advisor	Signature	Date
---------	-----------	------

Internal Examiner	Signature	Date
-------------------	-----------	------

External Examiner	Signature	Date
-------------------	-----------	------

Chair or School Dean	Signature	Date
----------------------	-----------	------



Declaration

I, the undersigned, declare that this thesis is my original work, that it has not been submitted for a degree at this or any other university, and that all sources of materials utilized in the thesis have been properly credited.

Tamerat Kebebew

Name

Signature

Place: Addis Ababa Institute of Technology, Ethiopia.

Date of Submission: _____

This thesis has been submitted for approval for examination by a university advisor.

Beneyam Berehanu(PhD)

Name

Signature

Abstract

Mobile network operators (MNOs) face an escalating demand for mobile data due to the growth of smart devices and services. Developing countries, Ethiopia included, are witnessing significant growth in mobile data traffic. The 5th generation mobile network (5G) has been explored and integrated into new standards to accommodate the data traffic growth. Ethio telecom has undertaken trials using the sub-band(3.5GHz) to cater to the swiftly growing data needs. The 5G sub-band(3.5GHz) is the mid-frequency band that offers wider bandwidth than the current mobile network spectrums. Yet, in pursuit of a better strategy for the future, MNOs are considering the millimeter wave 5G technology to increase bandwidth, reinforce capacity, and improve reliability.

This research focused on a comparative evaluation of the performance of the two 5G bands. A meticulously selected hotspot near Bole International Airport, covering a 2-square-kilometer area, is designated as the testing ground. The method combines components including radio network planning, coverage simulations, capacity evaluations, and cost assessments, and a tailored scenario analysis is executed. This procedure made use of the simulation software FEKO + Winprop 2020.

The research findings are significant. The range of the 5G millimeter wave (26 GHz) network covered a shorter distance, unlike the 5G sub-band (3.5 GHz), which covers greater distances. For instance, the radius of coverage for the 5G sub-band is 0.262 km, whereas for the 5G millimeter wave, it's 0.185 km. This implies that signals transmitted by 5G millimeter wave networks weaken after a relatively short distance, whereas signals from the 5G sub-band maintain their strength over greater distances without notable signal degradation.

Capacity simulations confirm that the 5G millimeter wave has a capacity exceeding twice that of the 5G sub-band, with values such as average cell throughput of 854.56 Mbps and 398.1 Mbps, respectively. The cost analysis underscores the cost efficiency of the 5G sub-band in the short term, while the 5G millimeter wave emerges as a more viable long-term solution due to its capacity advantages. Additionally, the payback period is 3.17 years for the 5G sub-band and 2.82 years for the 5G millimeter wave, further reinforcing the

long-term viability of the millimeter wave approach.

Keywords— *5G New Radio, Link Budget, Radio Planning, sub-band, Winprop, SS-RSRP, QoS, SINR, millimetric wave, and propagation model*

Acknowledgements

Primarily, I would like to thank the Almighty God and his Mother Holy Virgin Mariam for guiding me in every aspect while doing this study.

Furthermore, I would like to express my profound appreciation to my advisor, Beneyam Berehanu(Ph.D.). His unwavering encouragement, steadfast support, and invaluable guidance have been a driving force behind the successful completion of this thesis. Without his generous mentoring, this research endeavor would not have reached its conclusion.

Moving forward, my sincere gratitude is directed towards my evaluators, Dr. -Eng. Yihenew Wondie and Dr. Murad Ridwan. Their insightful recommendations, constructive feedback, and meticulous corrections have played an indispensable role in advancing my thesis. Their contributions have not only refined my work but have also instilled in me the determination to persevere through the entire research process.

Moreover, I want to extend my deepest appreciation to ethio telecom and Addis Ababa University, especially the Addis Ababa Institute of Technology, for bestowing upon me the scholarship opportunity that has enabled my pursuit of academic growth. I extend my heartfelt thanks to them for their generous support, which has propelled my educational aspirations.

Additionally, it is essential to convey my utmost appreciation to Dr. Seifu Girma. His unwavering support has been invaluable and deserving of the highest gratitude. His continuous assistance and guidance have left a profound impact, for which I am genuinely thankful for his dedication to my academic journey.

Equally significant is my heartfelt appreciation for my friends and colleagues. Your presence and unwavering support have made a significant impact, and I extend my heartfelt thanks to each of you.

Last, but certainly not least, I extend my sincere appreciation to my dear wife, Tigist Ayichew, and to my young daughter, Solyana, as well as my son, Olyad. Their boundless affection and unwavering support have been my guiding light and the wellspring of motivation throughout the entirety of the thesis process.

Table of Contents

Declaration	iii
Abstract	iv
Acknowledgments	vi
Table of Contents	vii
List of Figures	xi
List of Tables	xii
List of Acronyms	xiii
1 Introduction	1
1.1 Background and Motivation	1
1.2 Statement of the Problem	3
1.3 Objectives	4
1.3.1 General Objective	4
1.3.2 Specific Objectives	4
1.4 Methodology	5
1.5 Significance of the Study	6
1.6 Literature Review	7
1.7 Scope and Limitation	10
1.7.1 Scope of the Study	10
1.7.2 Limitation of the Study	11
1.8 Contribution	11
1.9 Thesis Outline	11
2 Background on 5G Technology	12
2.1 Evolution of Mobile Communication	12
2.2 Overview of 5G Technology	13

2.2.1	5G New Radio Network Architecture overview	15
2.2.2	5G Radio Protocol Architecture	17
2.2.3	5G Frame Structure	20
2.2.4	Waveforms and Modulation	21
2.2.5	5G New Radio Network Technology Requirements and Targets . .	25
2.2.6	Frequency Bands of 5G New Radio	25
2.2.7	Core Specification	27
2.2.8	massiveMIMO	30
2.2.9	Beamforming	31
2.2.10	5G Use Cases	33
2.3	Characteristics of 5G Sub-band(3.5GHz) and 5G mmwave(26GHz)	35
2.3.1	5G Sub-bands	35
2.3.2	Millimeter Waves (mmwave)	36
3	Radio Network Planning Background	37
3.1	Overview of Radio Planning	37
3.2	Radio Network Planning Phases	37
3.2.1	Preparation Phase	38
3.2.2	Nominal Planning Phase	38
3.2.3	Detail Planning Phase	38
3.2.4	Network Rollout Phase	38
3.2.5	Network Optimization Phase	39
3.2.6	Dimensioning Process	39
3.3	Coverage Planning	39
3.3.1	Radio link budget	40
3.3.2	Propagation models	45
3.3.3	Propagation Model Selections	50

3.3.4	Antenna Placement and Configuration	52
3.3.5	Coverage Evaluation Parameters	53
3.3.6	Coverage Based Site Counts	54
3.4	Capacity Planning	55
3.4.1	Capacity Calculation Based on Geographical Population	56
3.4.2	Network Capacity Evaluation and Performance Analysis	57
3.4.3	Capacity Requirements	58
3.4.4	Data volume per month	58
3.4.5	Capacity Based Site Count	60
3.5	Simulation	61
3.5.1	Site Survey	61
3.5.2	Digital Map	61
3.5.3	Simulation Work Flow	62
3.6	Radio Optimization	64
3.6.1	Azimuth Optimization	64
3.6.2	Tilt Adjustment	64
3.7	Techno-economic analysis of 5G mobile networks	64
4	Deployment Scenarios and Methodology	68
4.1	Deployment Scenario	68
4.1.1	Geographical Area	68
4.1.2	Network Topology	69
4.1.3	Frequency bands	70
4.2	Methodology	71
4.2.1	Requirements	71
4.2.2	Radio Link Budget Calculation	71
4.2.3	Coverage Calculation	76

4.2.4	Coverage Based Site Counts of 5G sub-band(3.5GHz)	78
4.2.5	Coverage Based Site Counts of 5G mmwave(26GHz)	78
4.2.6	Capacity Calculation	79
4.2.7	Define the Number of Base Stations	85
4.2.8	Optimum number of Base Station count by using Coverage and Capacity Table 4.7	85
4.2.9	Techno-economic Analysis	85
5	Simulation Results and Performance Comparisons	90
5.1	Simulation Results	90
5.1.1	Simulation Configurations using Winprop	90
5.1.2	4G-Advanced (2.6GHz) As Benchmark	92
5.1.3	Simulation of Sub-band (3.5GHz) on Existing 4G-Advanced Site	93
5.1.4	Simulation of Sub-band (3.5GHz) with Site Modification	93
5.1.5	Simulation of 5G mmwave (26GHz)	94
5.2	Network Coverage Performance Comparison	95
5.2.1	Coverage Radius Analysis	98
5.2.2	Coverage from capacity Perspective	99
5.3	Network Capacity Performance Comparison	101
5.3.1	Data Rate and Throughput Simulation Calculation	101
5.4	Network Quality Performance Comparison	104
5.4.1	SINR Comparison	104
5.4.2	Coverage and Capacity Discussion and Findings	107
6	Conclusion and Future work	110
6.1	Conclusion	110
6.2	Future Work	111
	Bibliography	112

List of Figures

1.1	World Mobile Subscribers	1
1.2	Data user of ethiotelecom increments[4]	2
1.3	General Methodology	6
2.1	5G Radio Access Network Standardization[16]	14
2.2	5G Overall Architecture[19]	17
2.3	5G user plane protocol stack[19]	18
2.4	5G control plane protocol stack[19]	19
2.5	Numerology and Slot length[21]	21
2.6	Overall Procedure for Waveform Generation[22]	23
2.7	How UE detect[33]	32
3.1	Radio link budget[38]	45
3.2	Type of site configurations (a) Omni-directional (b) Two-sector (c) Tri-sector[64]	55
4.1	(a) Addis Ababa Digital map (b) Selected area with existing base station	69
4.2	Coverage Dimensioning Flow Chart	76
4.3	Capacity flow chart	80
4.4	Revenue difference of 5G sub-band and 5G mmwave	88
4.5	Overall calculation of Techno-economic Analysis of 5G sub-band and 5G mmwave	89
5.1	Configure the parameter on Winprop simulator of 4G-Advance	91
5.2	4G-Advanced Simulation Result	92
5.3	5G sub-band(3.5GHz) on existing site Simulation Result	93
5.4	5G Modified sub-band on existing site Simulation Result	94
5.5	5G mmwave(26GHz) Simulation Result	95

5.6	4G-Advance SS-RSRP Simulation Result	96
5.7	5G Modified sub-band SS-RSRP Simulation Result	96
5.8	5G mmwave SS-RSRP Simulation Result	97
5.9	RSRP/SS-RSRP Analysis	98
5.10	Coveragr Comparison by using Radius from Table 5.1	99
5.11	5G sub-band(3.5GHz) coverage with 40 Mbps threshold Simulation Result	100
5.12	5G mmwave(26GHz) coverage with 100 Mbps threshold Simulation Result	101
5.13	4G-Advance capacity Simulation Result	102
5.14	5G modified sub-band capacity Simulation Result	102
5.15	5G mmwave(26GHz) capacity Simulation Result	103
5.16	Average throughput analysis	103
5.17	5G Network SS-RSRQ Simulation Result (a) 5G sub-band (b) 5G mmwave	104
5.18	4G Advanced SINR	105
5.19	5G mmwave(26GHz) SINR	106
5.20	5G sub-band(3.5GHz) SINR	106
5.21	SINR Comparative Analysis	107

List of Tables

2.1	Technical Requirements and Targets [26]	26
2.2	NR (New Radio) Operating Bands (Frequency Range 1)[28]	28
2.3	NR (New Radio) Operating Bands (Frequency Range 2)[29]	29
3.1	Coverage requirements and Standard Signal Strength indicators of LTE[63]	54
3.2	Subcarrier spacing with maximum resource block allocation in bandwidth	60
3.3	Overhead values for FR1 and FR2	60
4.1	5G sub-band(3.5GHz) Radio link budget	74
4.2	5G mmwave(26GHz) Radio link budget	75
4.3	Indicates the summary of the parameters and cell radius of sub-band(3.5GHz)	77
4.4	Indicates the summary of the parameters and cell radius of 5G mmwave(26GHz)	77
4.5	5G sub-band(3.5GHz) Capacity parameters with its value	81
4.6	Capacity parameters with its value for 5G mmwave(26GHz)	83
4.7	Optimum number of Base Station count by using Coverage and Capacity	85
4.8	CAPEX of 5G sub-band and 5G mmwave	87
4.9	OPEX of 5G sub-band and 5G mmwave	88
5.1	Differnt network technology of Coverage Radius	98

List of Acronyms

3GPP	Third-Generation Partnership Project
5G NR	5th Generation New Radio
AMF	Access and Mobility Management Function
ARPU	Average Revenue per User
AUSF	Authentication Server Function
BCCH	Broadcast Control Channel
BPSK	Binary Phase Shift Key
CAPEX	Capital expenditure
CP-OFDM	Cyclic Prefix OFDM
CSI-RS	Channel State Information Reference Signal
DFT-s-OFDM	Direct Fourier Transform Spread OFDM
DL	Down Link
DM-RS	Demodulation Reference Signal
ECA	Economic Commission for Africa
EDGE	Enhanced Data for Global Evolution
EIRP	Effective Isotropic Radiated Power
eMBB	Enhanced Mobile Broadband
EPC	Evolved Packet Core
E-UTRAN	Evolved Universal Mobile Telecommunications System Terrestrial RAN
FDMA	Frequency Division Multiple Access
gNodeB	Next-generation NodeB
IEEE	Institute of Electrical and Electronics Engineers
ITU	International Telecommunication Union
LOS	line of sight
MAPL	Maximum Allowable Pathloss

MIMO	multiple input multiple output
METIS	Mobile and Wireless Communications Enablers for the Twenty-Twenty Information Society
mmMAGIC	Millimetre-Wave Based Mobile Radio Access Network for Fifth Generation Integrated Communications
NAS	Non-Access Stratum
NEF	Network Exposure Function
NFR	Network Function Repository
NOMA	Non-Orthogonal Multiple Access
OFDM	Orthogonal Frequency Division Multiplexing
OTP	Open Transport Protocol
PBCH	Physical Broadcast Channel
PCF	Policy Control Function
PDCP	Packet Data Convergence Protocol
PDSCH	Physical Downlink Shared Channel
PUSCH	Physical Uplink Shared Channel
PSS	Primary Synchronization Signal
QoS	Quality of Service
QPSK	Quadrature Phase Shift Key
RAN	Radio Access Network
RLC	Radio Link Control
RRC	Radio Resource Control
SCS	Subcarrier Spacing
SDAP	Service Data Adaptation Protocol
SINR	Signal to Interference Plus Noise Ratio
SNR	Signal Interference to Noise Ratio
SSS	Secondary Synchronization Signal
UE	User Equipment
UPF	User Plane function

Chapter 1

Introduction

1.1 Background and Motivation

The rollout of 5G technology has opened new horizons for mobile communication, promising data rates beyond imagination and ushering in an era of unparalleled connectivity. As the demand for high-speed, low-latency, and reliable mobile services surges, telecommunication operators worldwide are striving to deploy 5G networks that can meet the exponential growth in data traffic and accommodate the expanding subscriber base.

As reported in [1], the global mobile subscriber count reached 8.3 billion in the second quarter of 2022 and is projected to surge to approximately 9.1 billion by 2027. Notably, the number of 5G subscriptions saw a remarkable increase of 70 million during the quarter, reaching a total of 690 million. It is anticipated that by the end of 2027, there will be a staggering 4.4 billion 5G subscriptions worldwide, accounting for 48 percent of all mobile subscriptions. Consequently, by 2027, 5G is expected to become the primary mobile access technology.

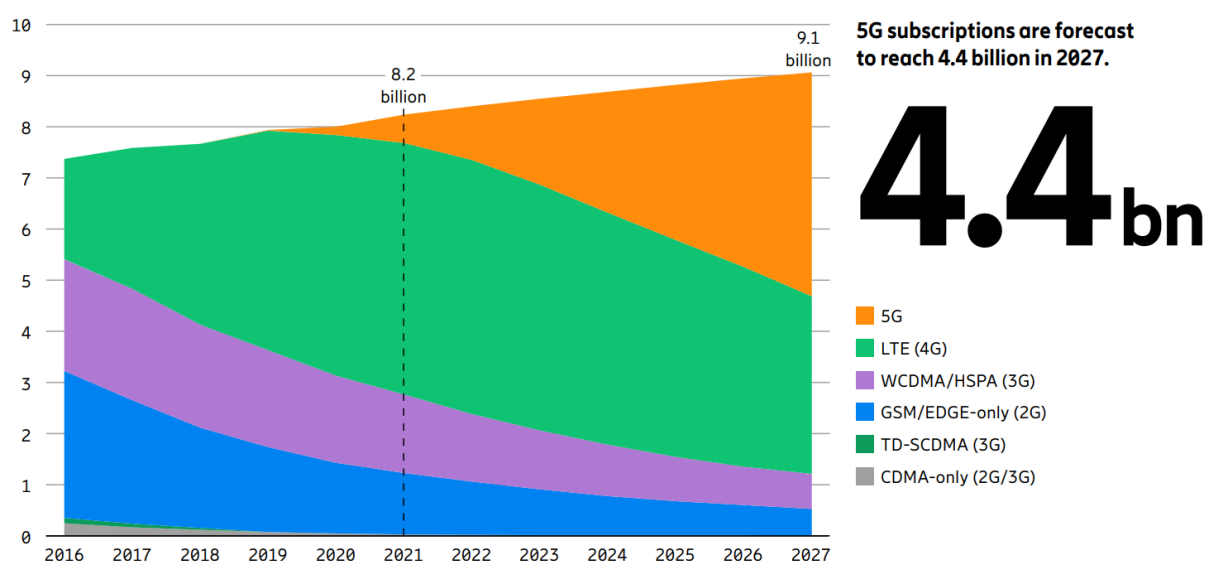

Figure 1.1: World Mobile Subscribers

In Sub-Saharan Africa, the adoption of 5G subscriptions is projected to surpass 10 percent

by 2027 [1]. Similarly, in Ethiopia, the growth in demand far exceeds the current count of 64.5 million total mobile subscribers, with a notable 26.1 million mobile data subscribers [2]. As indicated in [3], the consumption of mobile data is rapidly accelerating in Ethiopia, leading to ongoing capacity challenges that are likely to persist in the upcoming years.

With a multitude of frequency bands available for 5G deployment, operators must make well-informed choices based on their specific requirements and objectives. Two prominent frequency bands, the 5G sub-band at 3.5GHz and the 5G mmwave at 26GHz, have emerged as strong contenders for offering distinct advantages in terms of network performance[5].

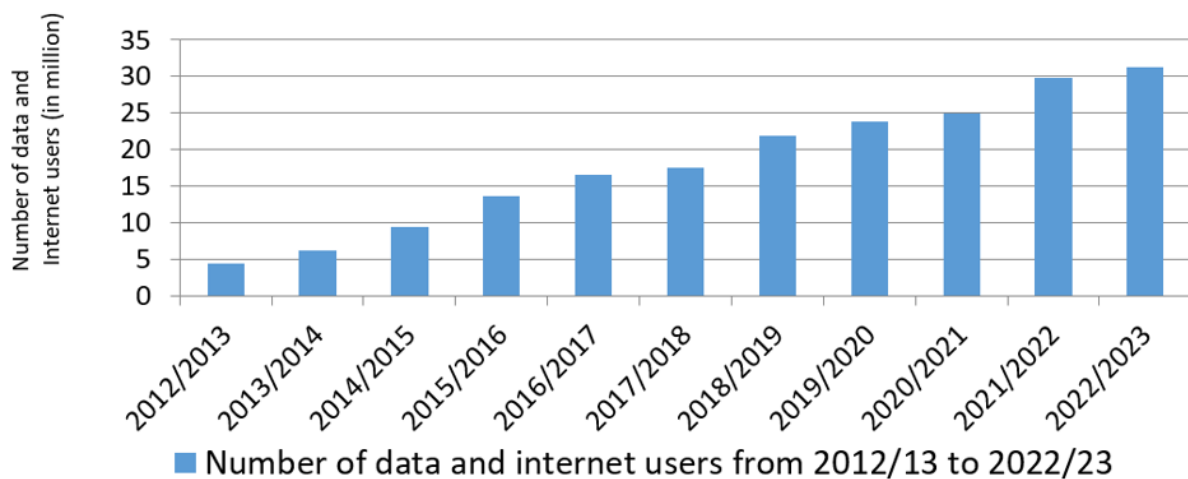

Figure 1.2: Data user of ethiotelecom increments[4]

The 5G sub-band at 3.5GHz strikes a balance between coverage and capacity, making it well-suited for providing wide-area coverage, particularly in urban environments. This band has the potential to serve a large number of subscribers with adequate data rates, which is crucial for supporting various applications ranging from enhanced mobile broadband to IoT services. On the other hand, the 5G mmwave at 26GHz stands out for its immense capacity and ability to deliver multi-gigabit data rates, making it ideal for densely populated areas with high data demands. However, the mmwave band exhibits challenges related to signal propagation, requiring the denser deployment of small cells to ensure adequate coverage[6].

This thesis aims to conduct an in-depth comparison of the 5G sub-band (3.5GHz) and 5G mmwave (26GHz) based on real-world data traffic and the number of subscribers

in operational 5G networks. By analyzing comprehensive datasets provided by major telecommunication operators, we seek to quantify and evaluate the network coverage, capacity, and cost performance of each frequency band. The findings from this research will enable stakeholders to make data-driven decisions regarding spectrum allocation, network deployment strategies, and infrastructure investments, ultimately fostering the efficient and widespread adoption of 5G technology.

1.2 Statement of the Problem

The rapid surge in data demands has compelled Ethio telecom to implement 4G and 4G-Advance technologies to meet the increasing requirements. In response to the ever-growing need for data capacity, the company has recently introduced 5G technology, commencing with the deployment of Massive MIMO with a Sub-band (3.5 GHz) frequency band. To further enhance data capacity, the deployment of 5G mmwave technology (High-band) has become indispensable. However, despite the critical importance of this technology for addressing data demands, there remains a notable absence of research and understanding regarding the coverage and capacity planning for 5G mmwave networks in the context of Ethiopia.

As such, the primary problem addressed in this thesis is the lack of comprehensive studies on 5G mmwave coverage and capacity planning in Ethiopia. The introduction of this advanced technology necessitates a thorough investigation and comparison of the coverage and capacity performance between the 5G sub-band (3.5GHz) and 5G mmwave (26GHz) in urban environments.

Research Questions:

1. Coverage Comparison: What are the disparities in coverage performance between 5G sub-band (3.5GHz) and 5G millimeter wave (26GHz) technologies? How do the propagation characteristics of these frequency bands impact coverage range and signal quality in urban settings?
2. Capacity Comparison: What are the variations in network capacity between 5G

sub-band (3.5GHz) and 5G millimeter wave (26GHz) technologies? How do factors like bandwidth availability and interference levels influence the achievable capacity in these frequency bands in urban areas?

3. Cost Comparison: What are the cost implications associated with deploying 5G sub-band (3.5GHz) and 5G millimeter wave (26GHz) networks? How do infrastructure costs, equipment costs, and operational expenditures differ between these frequency bands, particularly in an urban environment?

By addressing these research questions, the thesis aims to shed light on the suitability and effectiveness of 5G mmwave technology in Ethiopia's urban environments, considering both its radio coverage and capacity capabilities. This research is essential for effective network planning and the successful deployment of 5G mmwave networks, enabling Ethio telecom to harness the full potential of this cutting-edge technology to meet the escalating data demands of its users in a cost-efficient manner.

1.3 Objectives

1.3.1 General Objective

The general objective of the research on the coverage, capacity, and cost performance comparison of 5G sub-band (3.5GHz) and 5G millimeter wave (26GHz) technologies using radio planning and coverage and capacity simulation is to provide a comprehensive understanding of the performance differences between these frequency bands. The research aims to assist network operators, service providers, and stakeholders in making informed decisions regarding the deployment strategies of 5G networks.

1.3.2 Specific Objectives

The following specific objectives have been specified in order to attain the overall goal:

- To analyze and select the propagation model of 5G sub-band(3.5GHz) and 5G mmwave(26GHz)

- To evaluate and compare the coverage performance of 5G sub-band (3.5GHz) and 5G millimeter wave (26GHz) technologies using radio planning and coverage simulation techniques:
- To compare the capacity of 5G sub-band (3.5GHz) and 5G millimeter wave (26GHz) technologies using radio planning and capacity simulation techniques:
- To analyze the cost implications associated with the deployment of 5G sub-band (3.5GHz) and 5G millimeter wave (26GHz) networks using cost evaluation frameworks.

By achieving these specific objectives, the research aims to provide a comprehensive understanding of the coverage, capacity, and cost performance differences between 5G sub-band (3.5GHz) and 5G millimeter wave (26GHz) technologies. The findings will contribute to the body of knowledge in the field of 5G network planning and facilitate evidence-based decision-making for network deployments.

1.4 Methodology

The thesis "Coverage, Capacity, and Cost Performance Comparison of 5G Sub-band (3.5GHz) and 5G Millimeter Wave (26 GHz)" employs a methodological framework consisting of four main stages.

1. **Literature review** This step involves reading and understanding the existing research on the study of 5G coverage, capacity, and cost performance. To identify the gaps in the study and to develop the research questions.
2. **Data collection** This step involves collecting data on the coverage, capacity, and cost performance of the 5G sub-band (3.5GHz) and 5G mmwave (26GHz). The type of data collected will depend on the research questions asked. For example, collect data on the propagation characteristics of the two bands, the interference levels, and the energy efficiency.
3. **Mathematical model** This step involves developing a mathematical model to represent the system studied. This model can be prepared for simulation and the system under different conditions.
4. **Simulation** This step involves using the mathematical model to simulate the perfor-

mance of the 5G sub-band (3.5GHz) and 5G mmwave (26GHz) under different conditions. The simulation results interpret the data and answer the research questions.

5. **Interpretation of results** This step involves interpreting the simulation results and drawing conclusions about the coverage, capacity, and cost performance of the 5G sub-band (3.5GHz) and 5G mmwave (26GHz).

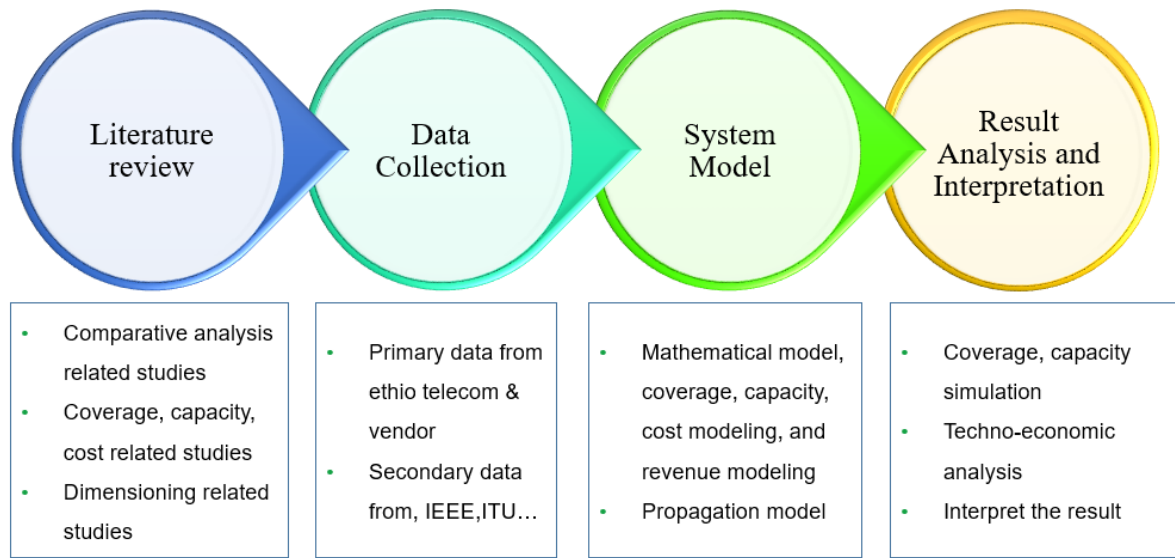

Figure 1.3: General Methodology

1.5 Significance of the Study

The significance of the thesis on "5G Mobile Radio Network Coverage, Capacity, and Cost Performance Analysis of 5G Sub-band (3.5GHz) and 5G mmwave (26GHz) in case of Addis Ababa, Ethiopia" is multifaceted and can have important implications for various stakeholders:

1. **Advancing Telecommunication Infrastructure:** The research can contribute to the development and advancement of telecommunication infrastructure in Addis Ababa by providing insights into the feasibility and performance of 5G networks. Understanding the coverage, capacity, and cost aspects will help telecommunication authorities and service providers make informed decisions on network deployment and investment.

2. **Informing Regulatory Decisions:** The analysis can offer valuable information to

regulatory bodies in Ethiopia, aiding them in developing appropriate policies, spectrum allocation, and guidelines for 5G network deployment. It can help ensure the efficient use of resources and the optimal development of 5G networks in the country.

3. Enhancing Connectivity and Digital Services: As 5G technology promises enhanced data rates and lower latencies, the findings of the thesis can help improve connectivity and enable the development of innovative digital services in Addis Ababa. This can potentially foster economic growth and technological advancements in the region.

4. Bridging the Digital Divide: Understanding the cost implications and performance of 5G networks in both urban and rural areas of Addis Ababa can contribute to bridging the digital divide. It can help identify opportunities to provide high-speed internet access and digital services to underserved regions.

5. Supporting Industry and Business: The analysis of cost performance can be of particular interest to businesses and industries in Addis Ababa. Knowledge of the cost-effectiveness of 5G deployment can encourage companies to invest in 5G infrastructure and take advantage of the benefits it offers, leading to potential advancements in various sectors.

6. Academic Contribution: The thesis can contribute to the academic community by expanding the knowledge base on 5G network performance in specific sub-bands. It can serve as a reference for future research and studies related to 5G deployment and optimization.

1.6 Literature Review

The literature review section in the introduction provides an overview of existing research and studies related to 5G network deployments, specifically focusing on the performance comparison of 5G sub-band and 5G millimeter Wave networks. The section serves to establish the current state of knowledge in the field and identify any gaps or limitations that the present study seeks to address.

In [7], the authors conduct a comprehensive analysis by considering various factors such as

signal propagation characteristics, antenna technologies, network deployment scenarios, user density levels, traffic patterns etc. Through simulations and mathematical models based on real-world data sets from urban environments with varying population densities, they compare the coverage range capabilities as well as capacity limitations between sub-band frequencies (below 6 GHz) commonly used in previous generations like LTE/4G systems versus mmwave frequencies (above 24 GHz), which are being explored for higher data rates but have limited propagation distances.

Additionally, the paper also examines the cost implications associated with deploying each frequency band by considering factors such as infrastructure requirements including base stations density needed for adequate coverage or capacity demands. Overall, this research provides valuable insights into understanding how different frequency bands perform in terms of coverage area, capacity, and costs within a given environment.

The study [8] discusses the performance analysis of 5G mobile radio networks in both sub-6GHz and mmwave bands, focusing on the n78 band (3.3-3.8GHz TDD) in Australia. It suggests applying LTE cell planning techniques to this 5G band and co-locating 5G NR on existing LTE base stations for initial rollout. The paper presents a link budget, coverage predictions, and trial measurements for a 5G NR trial at 3.5GHz, indicating similar coverage to LTE networks, with adjustments possible through beamforming or power changes. While it touches on spectrum support from 600MHz to mmwave bands, it notes higher frequencies bring increased bandwidth but also penetration losses, requiring distinct planning. However, it lacks an extensive mmwave analysis, suggesting further research for a comprehensive understanding.

According to [9], focuses on analyzing the coverage area and network planning using the Urban Micro (UMi) propagation model. The results provide insights into observed parameters such as SS-RSRP, SS-SINR, and data rate for different scenarios. This information can help in understanding the feasibility and performance of implementing 5G in an industrial area like Karawang. However, it does not specifically address topics related to sub-band analysis or cost performance analysis mentioned in your title.

In [10], the comparison of network planning in mid-band (2.6 GHz) and high-band (26 GHz) frequencies for 5G NR (New Radio). The study uses Mentum Planet 7.3 software

to simulate network coverage in Jababeka Industrial Estate. It shows that the LOS scenario performs better than the NLOS scenario, with higher data rates achieved at 26 GHz compared to 2.6 GHz. This information can help you understand how different frequency bands impact network performance in terms of coverage and data capacity for a specific area like Jababeka Industrial Estate. However, it does not specifically address cost performance analysis.

In [11], the dimensioning and optimization of a 5G New Radio network in a specific area of Addis Ababa, Ethiopia. The study aims to analyze the network performance and identify areas for improvement. The research methodology includes data collection, network modeling, and simulation. The results show that certain areas of the network experience high congestion and poor signal quality. Based on these findings, recommendations are provided for network optimization strategies in urban areas. However, this paper does not specifically focus on coverage analysis or cost performance analysis of different sub-bands or mmwave frequencies in 5G networks.

In [12], the analysis and optimization of 5G coverage predictions using a beamforming antenna model and real drive test measurements. The study discusses the importance of accurate coverage prediction for planning and optimizing wireless networks, particularly in the early deployment phase of 5G technology. It also explores different path loss models (3GPP and mmMAGIC) and evaluates their accuracy in predicting 5G coverage in various scenarios. Additionally, it investigates the use of machine learning algorithms to improve path loss modeling accuracy. However, this specific study does not focus on capacity or cost performance analysis related to sub-band or mmwave technologies specifically.

In [13], the study evaluates how these technologies perform in different environments such as urban areas with high population density or rural regions with sparse populations. It assesses their coverage capabilities by considering factors like penetration through obstacles. Additionally, the study examines the capacity potential offered by each technology in terms of data transfer rates, network efficiency, latency levels, etc., enabling stakeholders to determine which one is more suitable for specific use cases requiring high bandwidth.

Overall findings from this analysis will provide valuable insights into understanding how

different frequency bands affect network coverage while considering factors like data transfer rates and bandwidth availability across various scenarios. The comparative evaluation will help stakeholders make informed decisions based on budget considerations when selecting appropriate frequency bands for specific use cases or applications within mobile radio networks.

The literature reviews delve into the evaluation of coverage, capacity, and cost performance in 5G mobile radio networks, focusing on the n78 sub-band within sub-6GHz and acknowledging the challenges of mmwave frequencies. The reviews reveal the adaptability of LTE planning techniques for initial 5G deployment, highlighting similar coverage to LTE in the n78 band. Technical insights include link budgets, coverage predictions, and trial results at 3.5GHz while noting that mmwave frequencies offer higher bandwidth but with potential penetration losses, necessitating distinct planning strategies. However, the reviews admit to limited coverage of mmwave analysis and recommend further research for a comprehensive understanding of their performance in 5G networks.

1.7 Scope and Limitation

1.7.1 Scope of the Study

This thesis focuses specifically on Addis Ababa, Ethiopia, and narrows down to a specific area around Bole, covering a 2-kilometer square region. This ensures that the analysis remains relevant and specific to the target location. The thesis concentrates on the performance analysis of two key 5G frequency bands, namely, 3.5GHz (sub-band) and 26GHz (mmwave). The investigation will delve into aspects such as coverage, capacity, and cost performance of these bands. The thesis examines the 5G mobile radio network's performance in scenarios where there is a clear line of sight between the transmitters and receivers, considering outdoor conditions.

1.7.2 Limitation of the Study

The findings may not be directly applicable to other regions or cities, as the analysis is limited to the specific area around Bole, Addis Ababa. The thesis does not account for variations in network operator strategies, infrastructure quality, or spectrum allocation, which can significantly impact the results. While the thesis considers cost performance, it may have limitations in obtaining accurate and up-to-date cost data from network operators and infrastructure providers.

1.8 Contribution

The thesis contributes by conducting a comprehensive analysis of 5G mobile network performance in Addis Ababa, Ethiopia, focusing on the 3.5GHz sub-band and 26GHz mmwave band. The contributions of this work include an overall 5G radio planning approach involving mm-wave technology, spectrum analysis, and the identification of candidate bands. In the context of rapidly advancing technologies and increasing demand for wireless communication services, the planning of cellular radio networks, especially in terms of coverage and capacity, is a complex task. This research aims to provide insights and guidance for local engineers, supporting both strategic planning for MNOs and the Ethiopian Telecommunication Agency's regulatory frameworks. Additionally, the study offers optimization strategies for eAthiotelecom's existing network.

1.9 Thesis Outline

The thesis outline follows a structured progression: Chapter 2 provides a foundational understanding of 5G technology, Chapter 3 dives into radio planning principles, Chapter 4 outlines the methodology for deployment scenarios, Chapter 5 presents simulation results and performance comparisons, and the concluding chapter summarizes findings, underscores their significance, and suggests future research directions, creating a cohesive narrative that guides the reader through the research journey from background knowledge to practical applications and insights.

Chapter 2

Background on 5G Technology

2.1 Evolution of Mobile Communication

The evolution of mobile communication represents a remarkable journey through technological advancements that have shaped the way we connect and interact. Beginning with the emergence of the first-generation (1G) mobile systems, which introduced wireless voice communication, the subsequent generations have steadily expanded the capabilities of mobile networks, leading us to the era of 5G. This evolutionary path has been marked by pivotal milestones that have revolutionized the concept of connectivity.

The transition to second-generation (2G) mobile systems marked a significant leap, with the introduction of digital technology in the early 1990s. This transition led to improved voice quality, and enhanced encryption, and paved the way for text messaging, which would soon become an integral part of our daily communication. The shift from analog to digital paved the way for greater spectral efficiency, making mobile communication more accessible to a wider population.

The arrival of third-generation (3G) mobile systems heralded the era of mobile data. The early 2000s saw the introduction of 3G networks, enabling faster data transmission, basic internet access, and the emergence of multimedia services on mobile devices. This was a transformative step that laid the groundwork for the fourth-generation (4G) systems, with Long-Term Evolution (LTE) technology, delivering high-speed mobile broadband. 4G revolutionized how we consume media, use apps, and conduct business on mobile devices.

The transition to the fifth-generation (5G) technology is perhaps the most anticipated leap in mobile communication history. 5G promises to be a game-changer, not merely in terms of speed, but by redefining what mobile networks can achieve. With ultra-low latency, massive device connectivity, and support for diverse applications, 5G opens the

door to a new era of innovation. From IoT to augmented reality, 5G will enable previously unimaginable use cases, impacting various industries and revolutionizing the way we live and work.[14][15]

2.2 Overview of 5G Technology

The 5G New Radio (5G NR), representing the fifth generation of wireless access technology, is a significant advancement pioneered by the Third-Generation Partnership Project (3GPP), the primary objective addressing a diverse range of scenarios anticipated in the future evolution of mobile technologies. In contrast to its precursor, LTE (4G), 5G NR introduces a multitude of compelling advantages. It leverages higher frequency bands to support exceptionally wide transmission bandwidths, enabling the realization of extremely high data rates, catering to the ever-increasing demand for data-intensive applications.

Furthermore, 5G NR adopts an ultra-lean network design, enhancing energy efficiency and minimizing interference, thereby reducing the need for continuous transmissions and resulting in a more sustainable and environmentally friendly approach. Additionally, one of the pivotal features of 5G NR is its capability to sustain multiple subcarrier spacing configurations, leading to reduced latency. This low-latency characteristic is crucial in unlocking the potential for real-time interactions, enabling ultra-responsive applications such as autonomous vehicles, augmented reality, and remote medical procedures.

Moreover, 5G NR is designed with a forward-compatible mindset, ensuring that it can seamlessly integrate and support forthcoming, yet unknown, services and applications. Its beam-centric architecture further enables the extensive utilization of advanced techniques like beamforming, allowing for precise directional signal transmission, and accommodating a vast number of antenna elements. This design choice significantly improves the overall network performance, coverage, and capacity, enabling 5G NR to pave the way for a new era of connectivity and innovation[17].

3GPP Release 15 plays a pivotal role by providing specifications for both non-standalone and stand-alone modes of operation in the context of 5G technology. The non-standalone operation involves the integration of new facilities with existing LTE/LTE-Advanced net-

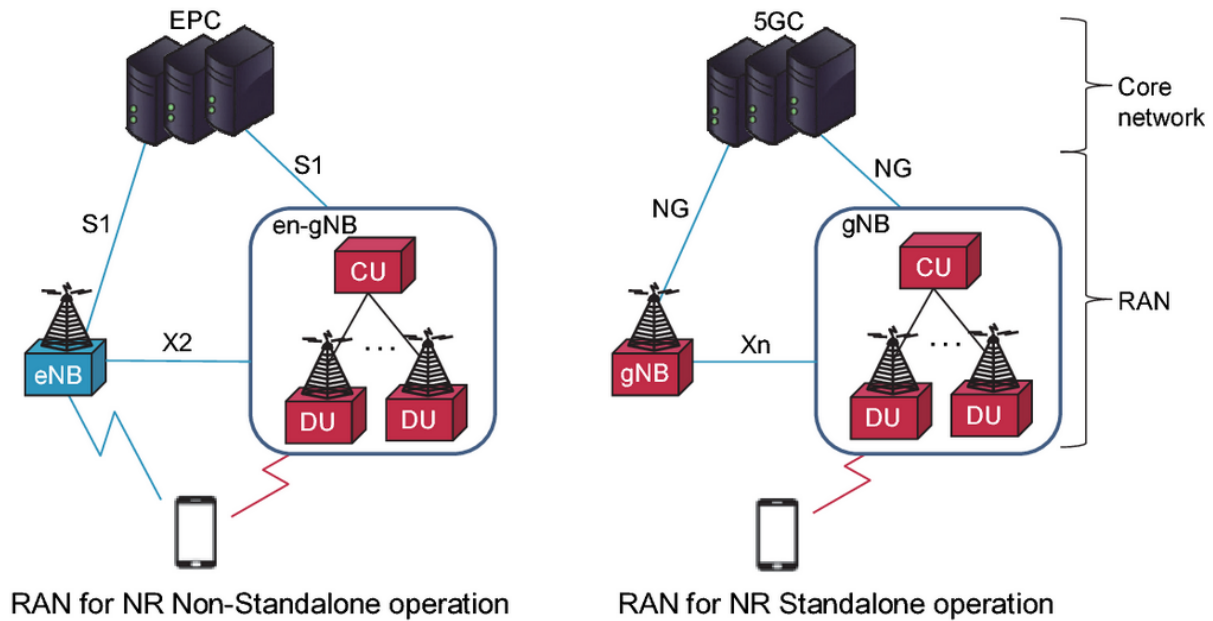

Figure 2.1: 5G Radio Access Network Standardization[16]

works, while the stand-alone operation empowers New Radio (NR) facilities to function independently. In the non-standalone mode, the familiar Evolved Packet Core (EPC) used for LTE networks is employed in the central network.

In contrast, for stand-alone operation, the novel 5G Core (5GC) takes center stage. It's important to highlight that the ongoing development of the 5G network means that there isn't a final consensus on its standardization yet. Nevertheless, there are active proposals for the implementation of this advanced network. This underscores the dynamic nature of the 5G landscape, with continuous advancements and discussions shaping the future of mobile communication.

For a more visual understanding, Figure 2.1 provides valuable insights into the operations of Standalone and Non-Standalone modes, respectively. These figures serve as valuable references, elucidating the contrasting functionalities of these operation modes within the evolving 5G framework, contributing to the broader understanding of the thesis's exploration of 5G mobile radio network coverage, capacity, and cost performance analysis, specifically focusing on the sub-band and mmwave aspects[18].

2.2.1 5G New Radio Network Architecture overview

The 5G New Radio (NR) network architecture presented in Figure 2.2. and encompasses various elements that work together to provide advanced wireless connectivity. Here's an overview of the key terms you mentioned, explained within the context of the 5G overall architecture:

CN (Core Network): The Core Network is a central part of the 5G architecture responsible for managing network functions, including user authentication, mobility management, connectivity, and routing of user traffic. It plays a crucial role in facilitating communication between user equipment (UE) and other network components.

EPC (Evolved Packet Core): The Evolved Packet Core was the core network architecture introduced in 4G LTE systems. In 5G, the 5G Core (5GC) is used. The EPC may still be utilized in non-standalone mode when combined with existing LTE networks, while the 5GC is used for standalone 5G operation.

NG-C (Next Generation Control Plane): NG-C refers to the next generation of the control plane in the 5G architecture. It includes advanced network functions for control and management, offering features like network slicing, support for diverse use cases, and efficient resource allocation.

NG-U (Next Generation User Plane): NG-U represents the next generation of the user plane in the 5G architecture. It focuses on handling user data traffic, ensuring efficient routing, low latency, and high-speed data transmission to support a wide range of modern applications and services.

Xn Interface - User Plane: The Xn interface, specifically in the user plane, facilitates seamless data transmission between adjacent gNBs (Next-Gen NodeBs) in the 5G Radio Access Network (NR-RAN). This interface ensures an optimal user experience during handovers and efficient resource allocation between neighboring cells.

Xn Interface - Control Plane: In the control plane, the Xn interface connects adjacent gNBs, enabling coordination of radio resources, handover management, and exchange of control signals. This interface is essential for maintaining smooth mobility, resource

allocation, and overall network management.

gNB (Next-Gen NodeB): The gNB is a core component of the 5G Radio Access Network (NR-RAN). It serves as the advanced base station that directly communicates with User Equipment (UE), such as smartphones, tablets, and IoT devices. The gNB manages wireless connections, data transmission, and reception, providing improved performance compared to previous generations.

AMF (Access and Mobility Management Function) / UPF (User Plane Function): The AMF is a key component in the 5G Core (5GC) network. It handles access and mobility management tasks, including session management, mobility handling, and connection setup for UEs. The UPF manages user plane traffic, ensuring efficient routing and forwarding of data packets.

5GC (5G Core): The 5G Core network is a central part of the 5G architecture, providing advanced network functions. It includes control plane and user plane separation, network slicing, support for diverse use cases, and improved scalability compared to previous core networks.

NR-RAN (New Radio - Radio Access Network): The NR-RAN is the radio access network component of the 5G system. It comprises gNBs that provide radio connectivity for UEs and connect to the 5G Core (5GC) network. The NR-RAN delivers high-speed wireless communication and supports the capabilities of 5G technology.

ng-eNB (Next-Generation evolved NodeB): While not a standardized 5G term, "ng-eNB" could potentially refer to an evolved version of the LTE eNB (evolved NodeB) with some 5G capabilities.

UE (User Equipment): UE, or User Equipment, represents devices used by end-users to access the 5G network. This includes smartphones, tablets, IoT devices, and other mobile gadgets that communicate with gNBs and leverage the capabilities of the 5G network.[19]

These terms collectively contribute to the comprehensive architecture of 5G New Radio

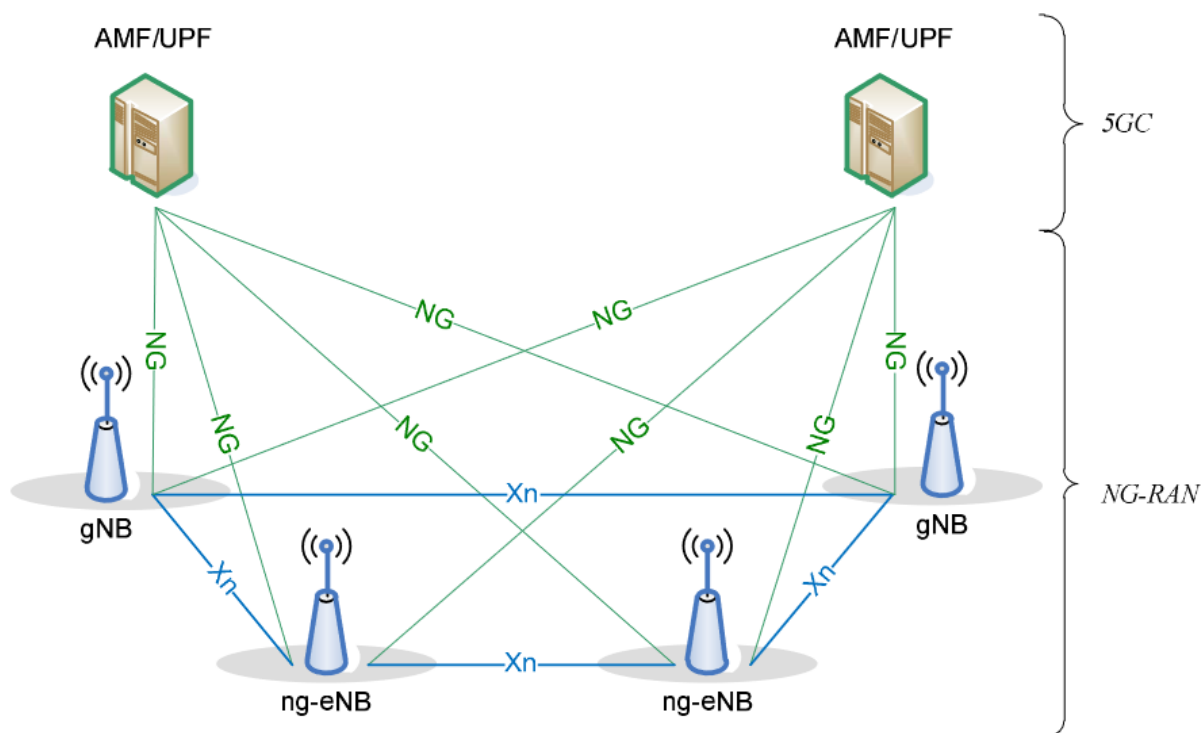

Figure 2.2: 5G Overall Architecture[19]

networks, enabling high-performance, low-latency connectivity, and supporting a wide range of applications and services.

2.2.2 5G Radio Protocol Architecture

User Plane

Figure 2.3 underneath illustrates the protocol stack pertaining to the user plane. Within this stack, SDAP, PDCP, RLC, and MAC sublayers execute the functions outlined, with their termination occurring at the gNB on the network side.

SDAP (Service Data Adaptation Protocol): SDAP is responsible for adapting and optimizing the service data for efficient transmission over the air interface. It handles functions like header compression, packet prioritization, and mapping different service flows onto bearers.

PDCP (Packet Data Convergence Protocol): PDCP is responsible for ensuring the

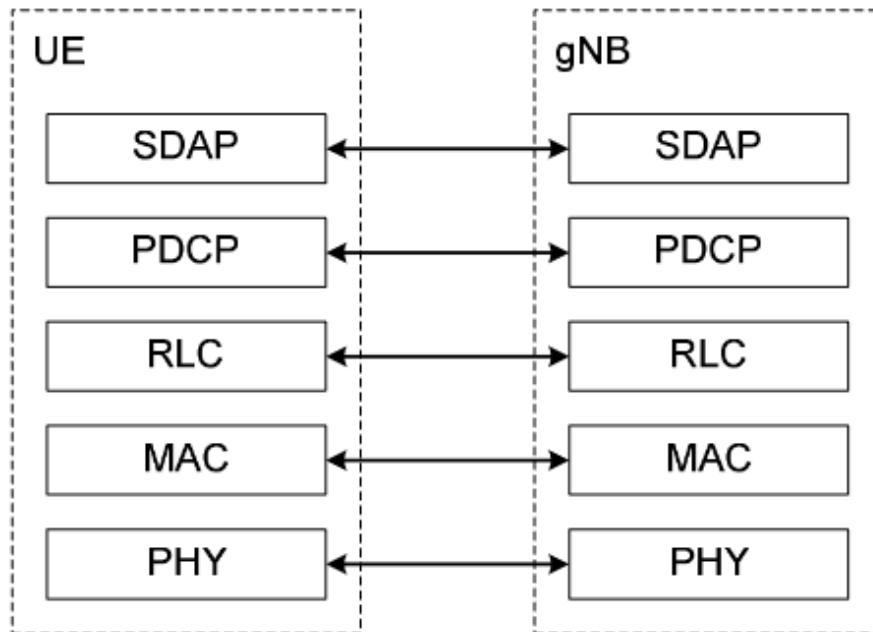

Figure 2.3: 5G user plane protocol stack[19]

integrity and security of user data during transmission. It performs tasks such as header compression, encryption, and duplicate detection.

RLC (Radio Link Control): RLC manages the reliability of the radio link by segmenting data into smaller units, performing error detection and correction, and managing the reordering of data packets.

MAC (Medium Access Control): MAC is responsible for managing access to the shared radio medium, scheduling transmissions, and controlling power levels. It ensures the efficient sharing of resources among multiple users.

PHY (Physical Layer): The PHY layer is the lowest layer in the protocol stack and is responsible for converting data into radio signals for transmission over the air interface. It includes tasks like modulation, coding, and RF signal generation.

These layers collectively form the user plane protocol stack, each contributing to the efficient and reliable transmission of data in the 5G mobile radio network.[19]

Control Plane

Figure 2.4 below demonstrates the arrangement of the protocol stack concerning the control plane. Within this arrangement:

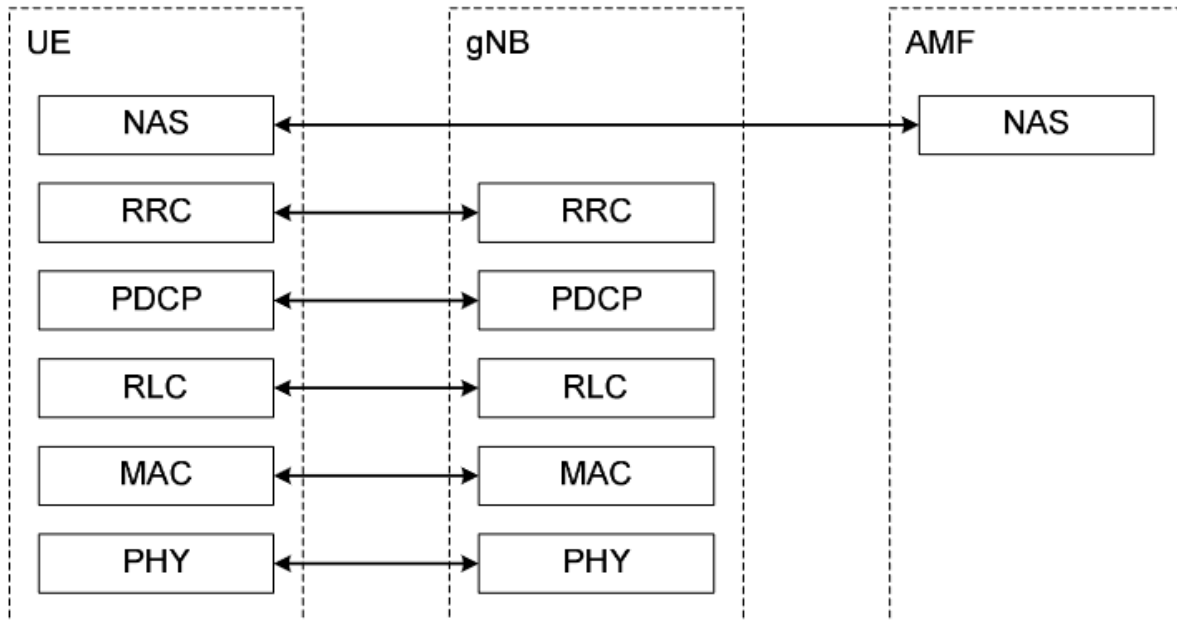

Figure 2.4: 5G control plane protocol stack[19]

The functions enlisted by PDCP, RLC, and MAC sublayers (culminating at the gNB on the network side) are carried out. The functions cataloged for RRC (culminating at the gNB on the network side) are also executed. The NAS control protocol (culminating at AMF on the network side) executes the tasks detailed in TS 23.501 [20]), encompassing functions such as authentication, mobility management, and security control. In this context, the terms "NAS" and "RRC" signify:

NAS (Non-Access Stratum): The Non-Access Stratum is a protocol layer responsible for managing functions such as authentication, mobility management, and session management for user equipment (UE) in the control plane. It interacts with the Access Stratum (AS) to ensure seamless communication.

RRC (Radio Resource Control): RRC is a protocol layer that manages the configuration and control of radio resources for communication between the UE and the network. It handles tasks like connection establishment, mobility management, and handovers. These layers, including NAS and RRC, collectively form the control plane protocol stack,

playing essential roles in maintaining reliable communication and efficient resource management in the 5G mobile radio network.[19]

2.2.3 5G Frame Structure

The 5G frame structure refers to the way in which data and control information are organized within the physical layer of a 5G wireless communication system. It outlines how data is divided into smaller units, how these units are transmitted over the airwaves, and how synchronization and control information are embedded to ensure proper communication between the base station and user devices.

5G frame structure is designed to be highly flexible and adaptable to accommodate various use cases and scenarios. It introduces a concept known as "numerology," which involves parameters like subcarrier spacing, symbol duration, and slot configuration. These parameters can be adjusted to suit different requirements, such as high data rates, low latency, or massive device connectivity.

Numerology

5G numerology is a fundamental concept that governs the arrangement of subcarriers, symbols, and time intervals within the physical layer of a 5G wireless communication system. It involves a set of parameters that define how data is transmitted over the airwaves, specifying aspects like subcarrier spacing, symbol duration, and slot configuration.

Key components of 5G numerology include:

Subcarrier Spacing: This parameter defines the frequency separation between adjacent subcarriers, which are the individual carriers used to carry data. Different subcarrier spacings can be chosen to optimize spectral efficiency and coverage for specific scenarios.

Symbol Duration: Symbols are basic units of transmission that carry data. The duration of symbols is determined by the chosen subcarrier spacing. Shorter symbols are advantageous for low-latency communications, while longer symbols can provide higher resilience against fading and interference.

Slot Configuration: Slots are groups of symbols within a frame, and their configuration can vary based on the desired balance between latency and data rate. More slots in a frame can lead to higher data rates, but it can also result in longer latency.

Time Intervals: 5G numerology also defines various time intervals within a frame, such as guard intervals and cyclic prefixes, which help mitigate multipath propagation and interference.[21]

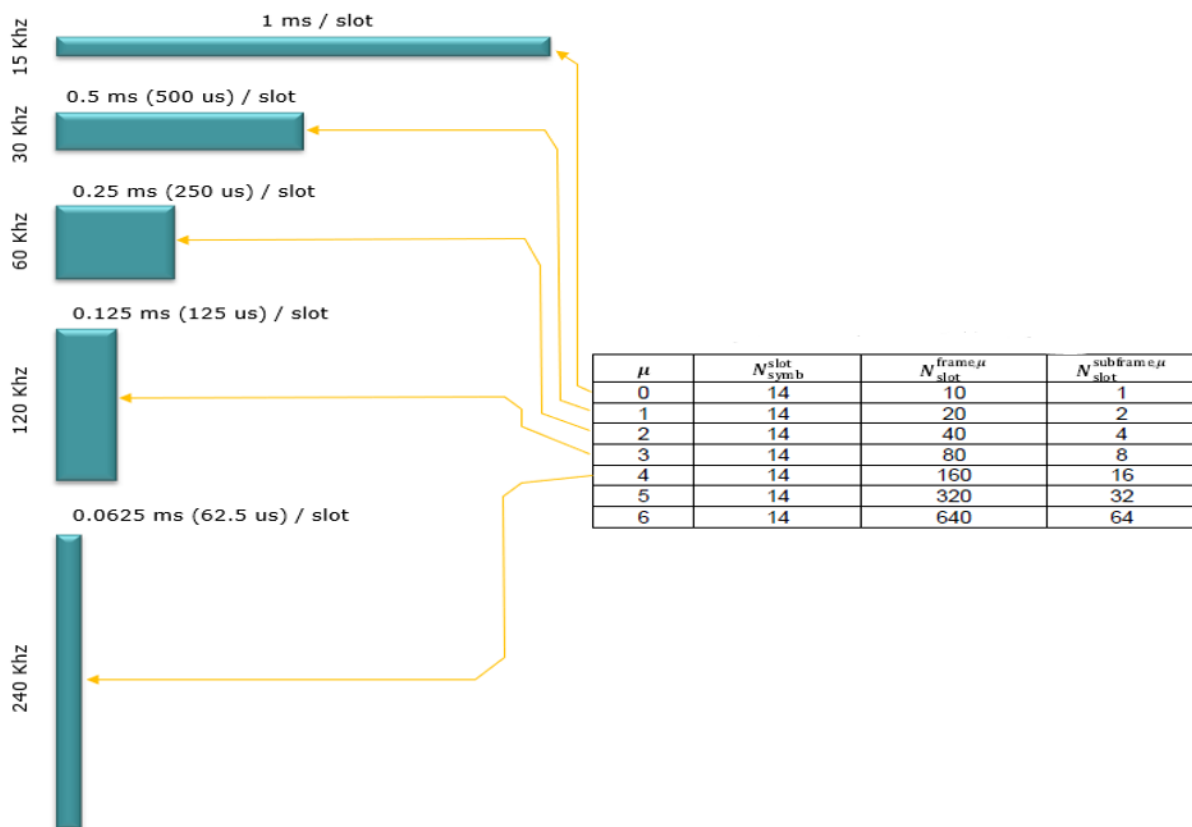

Figure 2.5: Numerology and Slot length[21]

2.2.4 Waveforms and Modulation

Waveforms in 5G

In 5G, waveform refers to the specific type of signal that is used to transmit data over the airwaves. The choice of waveform is a critical design consideration in wireless communication systems, as it directly affects factors like data rate, spectral efficiency, reliability, and power consumption. 5G employs different waveforms to optimize various aspects of

communication. One of the key waveforms used in 5G is Orthogonal Frequency Division Multiplexing (OFDM), which I'll explain in more detail below.

Orthogonal Frequency Division Multiplexing (OFDM): OFDM is a widely used waveform in 5G and other modern wireless communication systems. It is particularly well-suited for high-data-rate applications, frequency-selective fading environments, and efficient spectrum utilization. OFDM divides the available frequency spectrum into multiple narrow subcarriers, each carrying a portion of the data. These subcarriers are closely spaced, and they are orthogonal to each other, meaning that they do not interfere with each other even when transmitted in the same frequency band.

Certainly, here's a concise explanation of each of these terms in the context of 5G:

CP-OFDM (Cyclic Prefix Orthogonal Frequency Division Multiplexing): A modulation technique in 5G where a cyclic prefix is added before each OFDM symbol to combat multipath interference, enhancing signal reliability.

DFT-s-OFDM (Discrete Fourier Transform Spread OFDM): An advanced 5G modulation technique that spreads energy across multiple subcarriers using DFT to mitigate frequency-selective fading and improve performance.

Sub-Carrier Mapping: In 5G, assigning data and control signals to specific subcarriers in a structured grid, optimizing spectrum utilization, and enabling efficient communication.

IFFT (Inverse Fast Fourier Transform): In 5G, a process to convert data from the frequency domain to the time domain before transmission, allowing modulation onto subcarriers.

CP-Insertion (Cyclic Prefix Insertion): In 5G, adding a copy of the end part of an OFDM symbol before transmission to counter multipath effects, aids accurate data recovery at the receiver.[19]

Key features of OFDM in 5G:

1. **Spectral Efficiency:** OFDM allows efficient use of the available spectrum by dividing

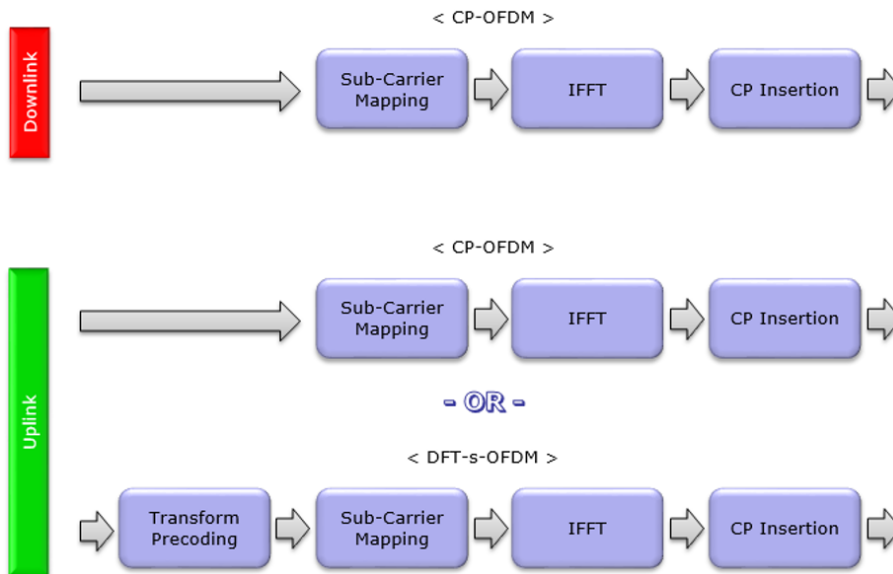

Figure 2.6: Overall Procedure for Waveform Generation[22]

it into many closely spaced subcarriers. This enables higher data rates compared to older modulation schemes.

2. **Resistance to Frequency-Selective Fading:** In wireless communication, signals may experience fading due to multipath propagation, where signals take different paths and arrive at the receiver with different delays. OFDM's ability to divide the data into multiple subcarriers helps combat this fading, as the impact of fading on each subcarrier is relatively small. This results in better overall reliability.

3. **Low Interference:** The orthogonality of the subcarriers in OFDM ensures minimal interference between them, even in dense frequency environments.

4. **Guard Intervals:** OFDM systems often use guard intervals between the subcarriers to account for potential delays caused by multipath propagation. These guard intervals help prevent inter-symbol interference.

5. **Adaptive Modulation and Coding (AMC):** OFDM enables adaptive modulation and coding, allowing the system to dynamically adjust the modulation scheme and error correction coding based on channel conditions. This optimizes performance in varying environments.

6. **Resource Allocation:** OFDM allows for flexible resource allocation, where different

users or devices can be assigned different subsets of subcarriers based on their communication needs.[23] [24]

Modulation schemes in 5G

Modulation in 5G, as in any wireless communication system, refers to the process of encoding information onto a carrier signal in order to transmit it over the airwaves. The carrier signal acts as a medium to carry the data from the transmitter to the receiver. By modulating the carrier signal's properties, such as amplitude, frequency, or phase, the information is embedded into the signal in a way that can be transmitted and then extracted at the receiver.

In 5G, modulation serves several important purposes:

1. **Data Encoding:** Modulation enables the representation of digital data in a format suitable for wireless transmission. Binary data (0s and 1s) generated by computers and devices need to be converted into analog signals that can travel through the air.
2. **Efficient Spectrum Utilization:** Different modulation schemes offer varying degrees of efficiency in terms of spectral utilization. By using more complex modulation schemes, 5G can transmit more data per unit of bandwidth, resulting in higher data rates.
3. **Data Rate and Capacity:** The choice of modulation scheme directly impacts the achievable data rate and capacity of the network. More advanced modulation schemes can transmit more bits per symbol, resulting in higher data rates.
4. **Spectral Efficiency:** Spectral efficiency refers to how efficiently the available frequency spectrum is used to transmit data. 5G aims to provide higher spectral efficiency than its predecessors, allowing more data to be transmitted within the same frequency band.
5. **Signal Quality and Robustness:** Different modulation schemes have varying degrees of resilience to noise and interference. By selecting appropriate modulation schemes, 5G can maintain signal quality and robustness even in challenging environments.

Common modulation schemes used in 5G include:

Quadrature Amplitude Modulation (QAM): QAM modulates both the amplitude and phase of the carrier signal. Higher-order QAM, such as 256-QAM, can transmit more bits per symbol but is more susceptible to noise and interference.

Phase Shift Keying (PSK): PSK modulates the phase of the carrier signal to represent different symbols. 5G might use various levels of PSK, such as 4-PSK or 8-PSK.

Amplitude Shift Keying (ASK): ASK modulates the amplitude of the carrier signal to represent different symbols. It's less commonly used in high-speed data communication due to its susceptibility to noise.

Frequency Shift Keying (FSK): FSK modulates the carrier signal's frequency to encode information. It's less common in 5G due to its limitations in terms of data rate and spectral efficiency.[25]

2.2.5 5G New Radio Network Technology Requirements and Targets

The provided Table outlines the essential technical performance criteria for IMT-2020 radio interfaces. These criteria are derived from a range of capabilities necessary to enable the functionalities required for 5G use cases and scenarios. Table 2.1 elaborates on the technical benchmarks and objectives pertaining to 5G New Radio.

Please remember that the values provided in this table are general indications and may vary based on factors such as deployment scenario, frequency bands used, network congestion, and technological advancements.

2.2.6 Frequency Bands of 5G New Radio

In the context of 5G (fifth-generation) mobile networks, Frequency Range 1 (FR1) and Frequency Range 2 (FR2) refer to different portions of the electromagnetic spectrum that are allocated for wireless communication. These frequency ranges are defined by regulatory bodies to ensure efficient and coordinated use of the spectrum for various

Table 2.1: Technical Requirements and Targets [26]

Parameter	Requirement	Indicative Value / Range
Max Data Rate	Significantly Higher	DL: 20 Gbps UL: 10 Gbps
Max Spectral Efficiency	Maximize Utilization	30bps/HZ, 15 bps/Hz
Customer Experience Data Rate	Consistently High	100 Mbps, 50 Mbps and above
Customer Level Latency	Ultra-Low	1 - 10 ms
Control Level Latency	Ultra-Low	1 - 5 ms
Connecting Density	High Density	1,000,000 devices per km ²
Consistency	Reliable and Consistent	Seamless across regions
Flexibility	Dynamic Adaptability	On-Demand Resource Allocation
Bandwidth	Utilize Wide Range	100 MHz and above

communication purposes. Here's a brief explanation of FR1 and FR2:

Frequency Range 1 (FR1): Frequency Range 1 covers frequencies in the sub-6 GHz range. It includes frequency bands that are lower in frequency and longer in wavelength. FR1 is well-suited for providing wide coverage, penetrating obstacles like buildings, and delivering reliable outdoor and indoor communication. Many of the 5G deployments worldwide, especially in the early stages, utilize FR1 due to its propagation characteristics and compatibility with existing cellular networks.

Some of the common frequency bands within FR1 for 5G include portions of the 600 MHz, 700 MHz, 1.4 GHz, 2.6 GHz, and 3.5 GHz bands, among others in Table 2.2.

Frequency Range 2 (FR2): Frequency Range 2 covers frequencies in the millimeter-wave (mmwave) range, typically above 24 GHz. FR2 provides significantly higher bandwidths, which can enable extremely high data rates and low-latency communication. However, mmwave signals have shorter wavelengths and are more sensitive to obstructions like buildings and foliage. As a result, mmwave frequencies are more suitable for densely populated urban areas and specific use cases like ultra-high-speed connections and high-capacity scenarios.

Common mmwave frequency bands within FR2 include portions of the 24 GHz, 28 GHz, 39 GHz, and 60 GHz bands, among others in Table 2.3.

Both FR1 and FR2 have their advantages and limitations. FR1 is well-suited for providing broad coverage and supporting legacy devices, while FR2 enables extremely high data rates but requires careful network planning due to its propagation characteristics. 5G networks often utilize a combination of both frequency ranges to achieve a balance between coverage and capacity, catering to a wide range of use cases and deployment scenarios.[27]

2.2.7 Core Specification

The 5GC provides a flexible and virtualized architecture that enables various services and use cases, including enhanced mobile broadband, massive IoT, and ultra-reliable low-latency communications. As of my last update in September 2021, here are some key aspects of the 5G core specifications:

Service-Based Architecture (SBA): The 5GC is designed using a service-based architecture, which allows functions to communicate through well-defined service-based interfaces. This enhances modularity, flexibility, and the ability to deploy services dynamically.

Network Slicing: Network slicing enables the creation of virtual, isolated networks tailored to specific use cases, industries, or services. Each slice has its own characteristics, performance requirements, and resources.

Control Plane and User Plane Separation (CUPS): The CUPS concept separates the control plane and user plane functions, enabling more efficient scaling and management of the network.

Session Management: The 5GC provides advanced session management capabilities for handling different types of devices, services, and communication patterns.

Table 2.2: NR (New Radio) Operating Bands (Frequency Range 1) [28]

NR Operating Band	Uplink Range(MHz)	Downlink Range (MHz)	Duplex Mode
n1	1920 – 1980	2110 – 2170	FDD
n2	1850 – 1910	1930 – 1990	FDD
n3	1710 – 1785	1805 – 1880	FDD
n5	824 – 849	869 – 894	FDD
n7	2500 – 2570	2620 – 2690	FDD
n8	880 – 915	925 – 960	FDD
n12	699 – 716	729 – 746	FDD
n20	832 – 862	791 – 821	FDD
n25	1850 – 1915	1930 – 1995	FDD
n28	703 – 748	758 – 803	FDD
n34	2010 – 2025	2010 – 2025	TDD
n38	2570 – 2620	2570 – 2620	TDD
n39	1880 – 1920	1880 – 1920	TDD
n40	2300 – 2400	2300 – 2400	TDD
n41	2496 – 2690	2496 – 2690	TDD
n48	3550 – 3700	3550 – 3700	TDD
n50	1432 – 1517	1432 – 1517	TDD
n51	1427 – 1432	1427 – 1432	TDD
n66	1710 – 1780	2110 – 2200	FDD
n70	1695 – 1710	1995 – 2020	FDD
n71	617 – 652	617 – 652	FDD
n74	1427 – 1470	1475 – 1518	FDD
n75	N/A	1432 – 1517	SDL
n76	N/A	1427 – 1432	SDL
n77	3300 – 4200	3300 – 4200	TDD
n78	3300 – 3800	3300 – 3800	TDD
n79	4400 – 5000	4400 – 5000	TDD
n80	1710 – 1785	N/A	SUL
n81	880 – 915	N/A	SUL

Table 2.3: NR (New Radio) Operating Bands (Frequency Range 2) [29]

Band	Common name	Uplink Range(MHz)	Downlink Range (MHz)	Duplex mode
n257	LMDS	26500 – 29500	26500 – 29500	TDD
n258	K-band	24250 – 27500	24250 – 27500	TDD
n260	Ka-band	37000 – 40000	37000 – 40000	TDD
n261	Ka-band	27500 – 28350	27500 – 28350	TDD

Network Function Virtualization (NFV): The 5GC utilizes NFV principles to virtualize network functions, allowing them to run on common off-the-shelf hardware and be dynamically orchestrated.

Network Exposure Function (NEF): The NEF allows authorized third-party applications to interact with the 5GC and access specific network services and functions.

Authentication and Security: The 5GC implements enhanced security measures to protect user data, ensuring end-to-end encryption and authentication.

Mobility Management: The 5GC provides improved mobility management for seamless handover between cells and access technologies.

Policy and Charging Control: Enhanced policy and charging control mechanisms enable operators to manage network resources, quality of service, and billing more effectively.

Support for IoT: The 5GC includes features designed to support massive IoT deployments, including low-power and low-latency communication requirements.

Edge Computing Support: The 5GC architecture allows integration with edge computing resources, enabling low-latency services and applications at the network edge. [30]

2.2.8 massiveMIMO

Massive MIMO (Multiple-Input Multiple-Output) is a key technology in 5G (fifth-generation) wireless networks that significantly enhances network performance by using a large number of antennas at the base station. It's a form of advanced MIMO technology designed to improve capacity, coverage, and overall spectral efficiency. In Massive MIMO, the number of antennas at the base station can be much larger than in traditional MIMO systems, often ranging from dozens to hundreds.

Here are some key features and benefits of Massive MIMO in the context of 5G:

Increased Spatial Multiplexing: Massive MIMO enables the simultaneous transmission and reception of multiple data streams to and from multiple user devices. By using a large number of antennas, the base station can serve multiple users in the same time-frequency resources, thereby increasing the network's capacity.

Improved Signal Quality and Coverage: The use of multiple antennas helps mitigate the effects of fading, interference, and signal reflections. This leads to improved signal quality, better coverage, and enhanced user experiences, even in challenging environments.

Higher Spectral Efficiency: Massive MIMO optimally allocates resources to users, increasing the spectral efficiency of the network. This results in higher data rates for individual users and more users being served simultaneously.

Enhanced Beamforming: The many antennas in Massive MIMO systems enable sophisticated beamforming techniques. Beamforming focuses the transmission energy towards the intended user, reducing interference and increasing signal strength.

Energy Efficiency: Due to its ability to focus energy, Massive MIMO systems can transmit signals with lower power, reducing energy consumption and extending battery life for user devices.

Interference Reduction: Massive MIMO's advanced signal processing can significantly mitigate interference, which is especially important in dense urban areas where many users are communicating simultaneously.

Flexible Spectrum Usage: With higher spatial degrees of freedom, Massive MIMO can dynamically allocate resources to different users based on their channel conditions, traffic demands, and quality of service requirements.

Support for Beam Management: Massive MIMO supports dynamic beam management, allowing the base station to adapt its beamforming patterns to user mobility and changing conditions.

Scalability: Massive MIMO is well-suited for future network growth and increased user demands. As more antennas are added to the base station, the network's capacity and performance can scale accordingly.

Massive MIMO is a critical technology in 5G networks and plays a significant role in achieving the promised high data rates, low latency, and massive device connectivity that 5G aims to deliver. It enables operators to efficiently serve a large number of users with diverse data needs while maximizing the utilization of available spectrum resources.[31]

2.2.9 Beamforming

Beamforming is utilized alongside phased array antenna systems to concentrate wireless signals toward a specific chosen direction, typically directed at a particular receiving device. This leads to an enhanced signal reception at the user equipment (UE), and also reduces the level of interference between individual UE signals.

Phased antenna arrays are meticulously engineered so that the radiation patterns emitted by each individual element synergize constructively, and those from neighboring elements unite to form an effective radiation pattern known as the main lobe. This main lobe efficiently transmits energy in the desired direction.

Simultaneously, the antenna array is meticulously designed to ensure that signals transmitted in undesired directions counteract each other destructively, creating areas of minimal signal strength known as nulls, as well as additional radiation lobes aside from the main lobe, termed side lobes.

The comprehensive antenna array system is purposefully designed to optimize the energy

radiated through the main lobe while maintaining energy levels in the side lobes within an acceptable threshold.

Manipulation of the main lobe's direction, or beam, is achieved through the adjustment of radio signals applied to each antenna element within the array.[32]

How UE detects

In simple terms, the gNB sends out a series of SSB beams in various directions, and the UE identifies the strongest beam from these. Then, the UE sends a PRACH signal to a designated location associated with a particular SSB beam ID. In other words, the gNB determines the SSB beam that the UE detected based on the PRACH location it received from the UE.

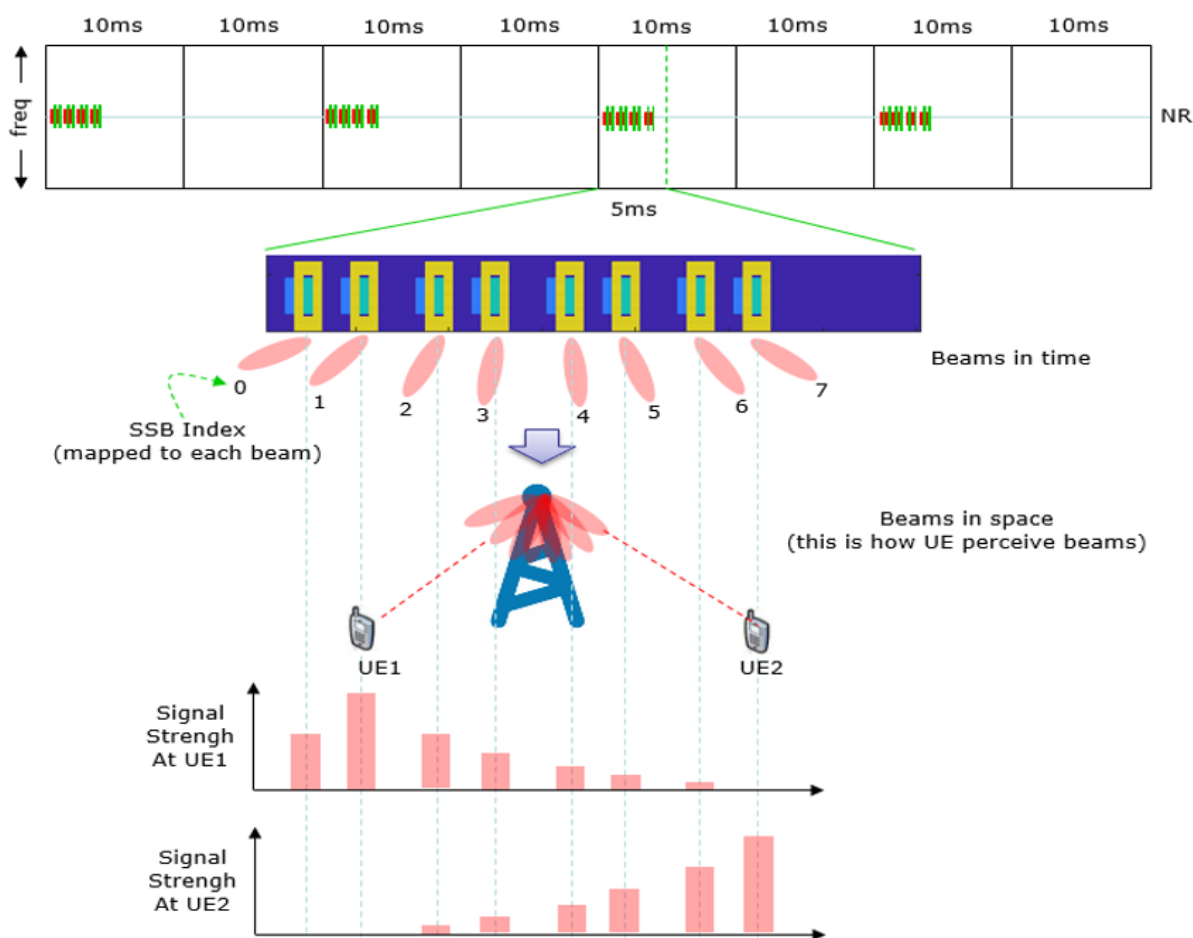

Figure 2.7: How UE detect[33]

Benefits of beamforming

Utilizing the principles of electromagnetic interference, beamforming enhances the precision of 5G connections, collaborating with MIMO to elevate the data throughput and connection density within 5G network cells.

The outcome of this technique is the generation of highly focused transmissions, which prove particularly advantageous for mmwave transmissions. These transmissions are susceptible to significant path loss and encounter challenges in penetrating obstacles like walls. With the aid of beamforming, the improved Signal-to-Noise Ratios (SNR) extend the reach of signals, benefiting both outdoor and, crucially, indoor coverage.

Another key advantage of beamforming is its capacity to eliminate or "nullify" interference. This capability is especially valuable in densely populated urban settings where numerous signal beams could potentially interfere with one another.

On the whole, beamforming's efficacy in reducing both internal and external interference, along with enhancing SNR, supports the implementation of advanced signal modulation schemes like 64QAM and 16QAM. These collective advancements contribute significantly to the enhancement of network cell capacity.[32]

2.2.10 5G Use Cases

5G, the fifth generation of wireless technology, presents a transformative shift with a wide array of innovative use cases across industries. With its enhanced capabilities in terms of speed, latency, and connectivity, 5G has the potential to revolutionize various sectors.

Enhanced Mobile Broadband (eMBB)

Enhanced Mobile Broadband (eMBB) is centered on how individuals utilize these networks. This encompasses activities such as streaming 8K videos, engaging in immersive experiences through Augmented Reality/Virtual Reality (AR/VR), accessing infotainment in connected transportation, and businesses supporting mobile broadband connectivity. The vital criteria within this domain include achieving ultra-high spectral effi-

ciency, facilitating extremely high data transmission rates, and minimizing interruption times.

All these aspects are effectively addressed by the 5G New Radio (NR) technology outlined in Release 15. As the infrastructure support for 5G NR continues to expand, these use cases will progressively become more widely accessible. This classification can be viewed as a blend of evolutionary and revolutionary trends, as the utilization of cellular connectivity in laptops is not entirely novel, yet the realization of immersive AR/VR experiences and other data-intensive applications was not feasible with previous generations of cellular networks.

Massive Machine Type Communications (mMTC)

This classification pertains to extensive machine-to-machine interactions, encompassing a vast number of connected devices within the Internet of Things (IoT). Predominantly, these devices operate using battery power and necessitate reliable connectivity with low latency, all while optimizing their energy usage. The primary challenge lies in ensuring scalability and dependable connectivity for the immense array of IoT devices that engage in sporadic and brief communication sessions. Achieving broad coverage and effective indoor penetration is essential, along with maintaining cost-effectiveness and energy efficiency.

Ultra-Reliable, Low-Latency Communications (URLLC)

This represents a truly groundbreaking aspect of 5G for many, as it introduces a level of performance previously unseen in practical applications. It can be likened to an amplified version of the Internet of Things (IoT). It encompasses domains such as advanced transportation, where vehicles can navigate intricate road scenarios and prevent collisions by collaborating with one another. It also encompasses use cases tied to the fourth industrial revolution, like time-sensitive factory automation.

Additionally, URLLC includes remote healthcare, involving devices that monitor vital signs and respond automatically or semi-automatically as required. This category ex-

tends to remote medical procedures, such as surgeries conducted in ambulances, during emergencies, or in remote regions, with real-time guidance from a distant doctor. In all these scenarios, a remarkably stable connection is imperative, operating with end-to-end latency rates of approximately a millisecond or less. The specific attributes needed to facilitate URLLC are currently being defined and will be incorporated into Releases 16 and 17. In essence, URLLC embodies the forthcoming direction of 5G, even if this future is just a few years away.[34]

2.3 Characteristics of 5G Sub-band(3.5GHz) and 5G mmwave(26GHz)

5G networks encompass a range of frequency bands, each with distinct characteristics that cater to specific use cases and deployment scenarios. This section delves into the unique attributes of sub-6GHz bands and millimeter waves, shedding light on their advantages and challenges.

2.3.1 5G Sub-bands

Advantages

Coverage: Sub-bands exhibit superior coverage capabilities due to their longer wavelengths. Signals in this range can propagate over longer distances and are less prone to blockage by obstacles.

Penetration: Sub-6GHz signals can penetrate buildings and obstacles more effectively, making them suitable for indoor and urban environments.

Stability: These bands are less affected by atmospheric conditions, making them more stable for communication.

Challenges

Limited Spectrum: The available spectrum in sub-6GHz bands is relatively limited, leading to potential congestion as the number of connected devices increases.

Capacity Limitations: While offering good coverage, sub-bands might face challenges in providing ultra-high data rates and massive capacity demanded by certain 5G use cases.

Interference: Due to wider coverage, the potential for interference from adjacent cells or neighboring networks is higher.

2.3.2 Millimeter Waves (mmwave)

Advantages

High Capacity: Millimeter waves offer significantly higher bandwidth, enabling multi-gigabit data rates and meeting the demands of data-intensive applications.

Low Congestion: The abundance of available spectrum in mmwave bands reduces the likelihood of network congestion.

Enhanced Spectral Efficiency: Smaller wavelengths enable more efficient frequency reuse patterns, leading to better spectral efficiency.

Challenges

Limited Range: Millimeter waves have limited range due to higher free-space path loss and sensitivity to obstacles, necessitating dense deployment of small cells.

Blockage and Fading: Signals at these frequencies are susceptible to blockage by buildings, trees, and even rain. This can cause signal attenuation and fading.

Complex Beamforming: Millimeter waves require sophisticated beamforming techniques to overcome propagation challenges and ensure stable connections.

Chapter 3

Radio Network Planning Background

3.1 Overview of Radio Planning

Constructing a radio network is a multifaceted endeavor necessitating thorough radio planning due to several critical factors. Spectrum allocation limitations, as a foundational concern, demand meticulous allocation of the finite radio spectrum to prevent interference and ensure efficient utilization. Moreover, the rapid emergence of new data services and technologies requires proactive planning to accommodate diverse service requirements, such as high data rates and low latency, thus enabling the network to adapt to evolving user needs.

Simultaneously, the need for network extension in the future of existing networks requires seamless integration and expansion planning to maintain service quality, prevent coverage gaps, and manage interference. Furthermore, radio planning plays a pivotal role in optimizing costs while ensuring network service quality, striking a balance between resource efficiency and user experience. Ultimately, efficient resource utilization is at the core of radio planning, minimizing waste, reducing environmental impact, and enhancing the sustainability of radio networks in an era of increasing connectivity demands.

3.2 Radio Network Planning Phases

The Radio Network Planning Process for both 5G sub-band (3.6GHz) and 5G mmwave (26GHz) frequencies encompasses several key phases: Preparation, Nominal Planning, Detail Planning, Network Rollout, and Network Optimization.

Here's an overview of each phase:

3.2.1 Preparation Phase

This phase involves collecting relevant data, including geographical information, existing network infrastructure, and regulatory requirements. For the 5G sub-band, focus on assessing population density and coverage needs. For 5G mmwave, consider building structures, obstacles, and blockage scenarios. This data forms the foundation for subsequent planning steps.

3.2.2 Nominal Planning Phase

In this phase, preliminary planning occurs based on high-level requirements. Determine the approximate number and locations of base stations, taking into account coverage and capacity needs. Frequency band allocation is initiated, considering the characteristics of each band. This phase provides a conceptual layout of the network's footprint.

3.2.3 Detail Planning Phase

Detailed planning involves refining the network design based on more granular data. Define precise antenna positions, orientations, and power levels. For the 5G sub-band, plan macro and micro cell deployment for comprehensive coverage. For 5G mmwave, deploy small cells in high-density areas to address shorter propagation ranges.

3.2.4 Network Rollout Phase

During this phase, physical deployment of the network takes place. Base stations are installed, connected, and integrated into the overall infrastructure. For the sub-band, focus on achieving seamless coverage across urban, suburban, and rural areas. In mmwave, small cells are placed strategically for targeted high-capacity coverage.

3.2.5 Network Optimization Phase

After deployment, the network is optimized to achieve optimal performance. In the sub-band, consider handover algorithms, interference mitigation, and parameter fine-tuning for seamless connectivity. For mmwave, focus on beamforming calibration, mitigating blockage effects, and addressing small cell interference to ensure consistent service.

Each phase is iterative, and adjustments may be made based on real-world observations and measurements. The unique characteristics of the 5G sub-band and mmwave frequencies influence the considerations in each phase, such as antenna design and propagation modeling. Successful execution of this process ensures a well-designed, efficient, and optimized network that meets coverage, capacity, and performance objectives in line with the characteristics of each frequency band.

3.2.6 Dimensioning Process

The dimensioning process in 5G mobile radio planning involves determining the necessary network parameters and configurations to achieve desired coverage, capacity, and cost performance for different frequency bands, such as the 5G sub-band (3.5GHz) and 5G mmwave (26GHz). This process ensures that the network is designed to meet specific requirements and objectives[35].

3.3 Coverage Planning

Coverage planning involves determining the appropriate cell layout and positioning of base stations (gNBs) to achieve the desired coverage area. It provides the maximum area that can be concealed by a base station. Coverage dimensioning comprises radio link budget and coverage analysis.

3.3.1 Radio link budget

The radio link budget for the 5G sub-band (3.5GHz) and 5G mmwave (26GHz) involves a series of calculations and parameters that determine the overall signal strength between a base station and user equipment. For the sub-band, factors like transmitter power, antenna gains, free space path loss, receiver sensitivity, and cable losses are considered along with safety margins to account for uncertainties. In the mmwave range, similar factors apply, but the unique characteristics of mmwave propagation, such as increased free space path loss and potential higher cable losses, necessitate careful consideration of these elements to ensure reliable communication between the base station and user equipment.

3.3.1.1 Radio link budget parameters

Each of these parameters in the context of the radio link budget for both 5G sub-band (3.6GHz) and 5G mmwave (26GHz):

Morphology: Morphology refers to the physical characteristics of the environment where the wireless communication system operates. It includes factors such as urban, suburban, or rural settings, which affect signal propagation, reflections, and obstacles.

Cell Edge Coverage Probability: Cell edge coverage probability represents the likelihood that user equipment (UE) at the edge of a cell will maintain a reliable signal connection. It measures the probability of maintaining a certain quality level at the cell boundary. The minimum net throughput that a single user equipment (UE) needs to achieve at the cell edge. This requirement sets a threshold for the service quality that must be provided at the outer limits of the cell's coverage area. It can also establish the minimum achievable Modulation and Coding Scheme (MCS) to ensure reliable communication. Typically, this parameter is determined by the network operator based on the specific services and performance expectations at the cell edge.[36]

User Environment: The user environment considers factors like user density, mobility patterns, and interference levels. It helps characterize the type of users and their behaviors

in a given area, which impacts network capacity and performance.

Data Channel Type: Data Channel Types in the context of wireless communication, particularly in cellular networks like 5G, refer to specific channels used for transmitting data between the base station (gNB) and user equipment (UE). Two commonly used data channels in 5G are PDSCH (Physical Downlink Shared Channel) and PUSCH (Physical Uplink Shared Channel):

PDSCH (Physical Downlink Shared Channel): PDSCH is a downlink data channel used to transmit user data from the gNB to the UE. It is responsible for delivering various types of data, including user-specific data, broadcast information, and system control information. PDSCH employs various modulation and coding schemes (MCS) to adapt to the channel conditions and deliver data reliably to the UE.

PUSCH (Physical Uplink Shared Channel): PUSCH is an uplink data channel used for transmitting user data from the UE to the gNB. UEs share the PUSCH channel for sending their data to the gNB. Similar to PDSCH, PUSCH also adapts its modulation and coding schemes based on the channel conditions to ensure successful transmission of user data to the gNB.[25] [37]

Number of Layers: The number of layers refers to the spatial multiplexing in a MIMO system. It indicates how many independent data streams can be transmitted and received concurrently using different antenna elements, enhancing capacity and data rates.

Duplex Mode: The duplex mode defines how the uplink and downlink communication occurs. Frequency Division Duplexing (FDD) uses separate frequencies for uplink and downlink, while Time Division Duplexing (TDD) uses the same frequency with time division.

Operation Frequency: Operation frequency is the specific frequency band at which the communication system operates. For 5G, this can be either 3.5GHz for sub-band or 26GHz for mmwave.

Operation Bandwidth: Operation bandwidth is the range of frequencies allocated for communication. In this case, it's 100MHz for sub-band and 400MHz for mmwave.

UE Antenna Height: UE antenna height is the height of the user equipment's antenna.

It affects signal propagation and path loss.

Data Rate: The data rate is the rate at which data is transmitted or received, indicating the speed of communication.

gNB Tx Power: gNB Tx power is the transmit power of the base station. It determines the signal strength transmitted by the network.

gNB Antenna Gain: gNB antenna gain refers to the directional gain of the base station antenna, influencing the coverage area.

Cable Loss: Cable loss represents signal attenuation in the connecting cables, affecting overall signal strength.

EIRP: Effective Isotropic Radiated Power (EIRP) is the power radiated from an ideal isotropic antenna, accounting for antenna gain.

$$EIRP = P_{Tx} + G_{Tx} - Cableloss_{Tx} \quad (3.1)$$

Where;

P_{Tx} : *isthetransmitterpower(dBm)*

G_{Tx} : *isthetransmitterantennagain(dBi)*

UE Noise Figure: UE noise figure measures how much additional noise the user equipment adds to the received signal. A distinctive value for the noise figure is among 6 to 8 dB.

Temperature: Temperature is the ambient temperature in the environment, impacting signal propagation and noise levels.

Boltzmann Constant: Boltzmann constant relates noise temperature to the noise power, influencing thermal noise calculations.

Max Number of Resource Blocks: Max number of resource blocks defines the maximum number of frequency blocks available for communication.

Subcarrier Spacing: Subcarrier spacing is the frequency separation between adjacent

subcarriers in OFDM modulation.

PRB Size: Physical Resource Block (PRB) size determines the data capacity of each block in the communication system.

Thermal Noise: Thermal noise is the noise level introduced by temperature, affecting the signal-to-noise ratio.

$$N = KBT \quad (3.2)$$

Where:

K: indicates the Boltzmann constant ($1.38 \times 10^{-23} \text{J/K}$);

T: specifies absolute temperature at a value of 290K;

B: indicates channel bandwidth which is 20MHz.

Receiver Noise Figure: The receiver noise figure quantifies the noise added by the receiver, affecting overall signal quality.

SINR: Signal-to-Interference-plus-Noise Ratio (SINR) indicates the ratio of useful signal to interference and noise. Accordingly, SINR is a vendor-specific parameter.

Receiver Sensitivity: Receiver sensitivity is the minimum signal strength required for reliable communication.

$$\text{Receiver Sensitivity} = \text{Noise figure} + \text{SINR} + \text{Thermal noise} \quad (3.3)$$

Control Channel Overhead: Control channel overhead accounts for additional data sent for control purposes.

UE Antenna Gain: As outlined by the regulations set by 3GPP, user equipment (UE) is mandated to incorporate a basic antenna that possesses a gain of 0 dBi for each individual antenna port.

Rx Antenna Gain: Rx antenna gain represents the gain of the user equipment's receiving antenna.

UE Maximum Total Transmitter Power: Refers to the transmission power of the

user equipment (UE), which depends on the specific power category assigned to the UE. Currently, only one power category is defined in the 3GPP TS 36.101 standard, known as class 3, which allows for the highest transmit power of 23dBm.

Body Loss: Body loss accounts for signal attenuation due to the human body, relevant for wearable devices.

Shadow Fading Loss: Shadow fading loss models signal attenuation due to obstacles in the environment.

Interface Margin: Interface margin provides a buffer to account for uncertainties in the communication environment.

Maximum Allowed Propagation Loss: Maximum allowed propagation loss defines the acceptable limit of signal loss.

$$\text{Pathloss (dBm)} = \text{gNodeB transmit power (dBm)} - 10 \log_{10}(\text{subcarrier quantity}) + \text{gNodeB antenna gain (dBi)} - \text{gNodeB cable loss (dB)} - \text{penetration loss (dB)} - \text{foliage loss (dB)} - \text{body block loss (dB)} - \text{interference margin (dB)} - \text{rain/ice margin (dB)} - \text{slow fading margin (dB)} + \text{UT antenna gain (dB)} - \text{thermal noise figure (dBm)} - \text{UT noise figure (dB)} - \text{demodulation threshold SINR (dB)} [38]$$

BS Antenna Height: BS antenna height refers to the height of the base station's antenna.

UE Antenna Height: UE antenna height is the height of the user equipment's antenna.

Cell Radius: Cell radius represents the coverage area of a cell in the network.

These parameters collectively influence the radio link budget, helping to design, plan, and optimize wireless communication systems for optimal coverage, capacity, and performance in both 5G sub-band (3.5GHz) and 5G mmwave (26GHz) frequency bands. Compute the upper limit of the signal strength margin within a 5G NR network, contingent on factors like cell radius, gNodeB/UT arrangement, propagation model, and attenuations. This entails evaluating the link budget, which signifies the received signal level and subsequently contrasting it with the minimum sensitivity threshold of the re-

ceiver. This comparative analysis elucidates whether the radio channel’s condition aligns with the necessary criteria for successful operation or not. Furthermore, this process offers insights into the status of the radio channel as well as the coverage range, influenced by the cell radius.

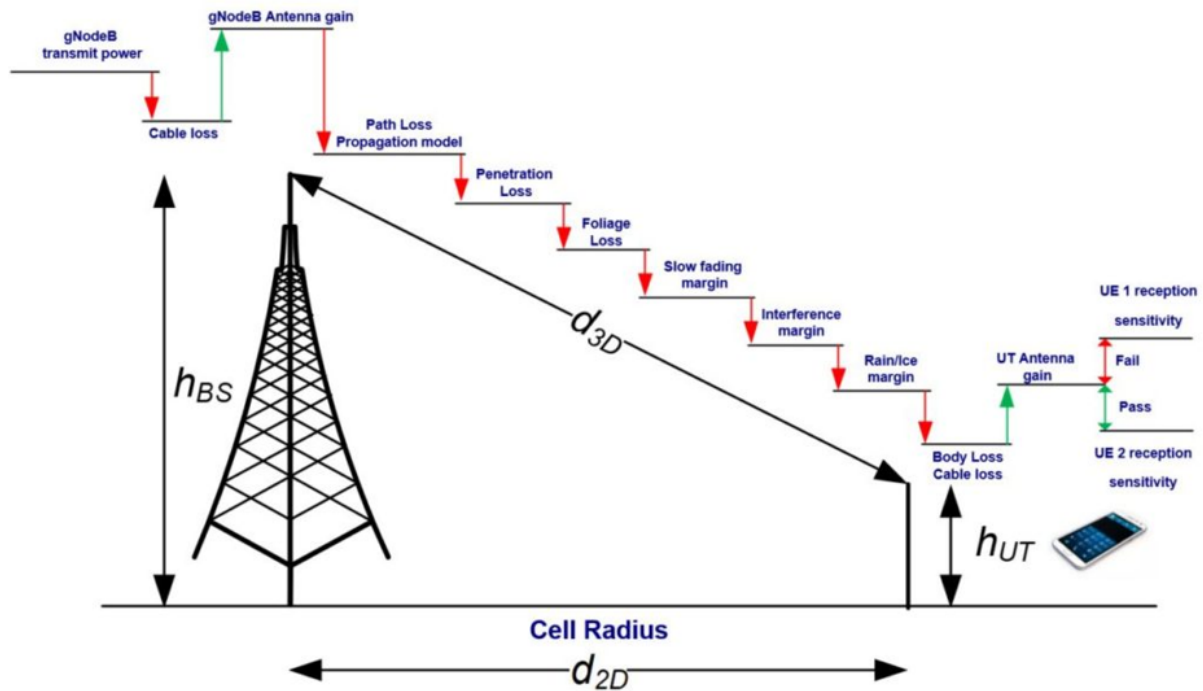

Figure 3.1: Radio link budget[38]

3.3.2 Propagation models

3.3.2.1 5G sub-band propagation models

There are several channel propagation models that can be used for the 5G sub-band (3.5GHz) to predict how wireless signals will propagate in different environments. Each model is designed to capture specific aspects of signal propagation and is suited for different deployment scenarios.

Here are a few commonly used channel propagation models with explanations:

Okumura-Hata Model: The Okumura-Hata model is an empirical path loss model that considers distance, frequency, and base station and mobile antenna heights to estimate path loss. It is suitable for urban and suburban environments where signal reflections and diffraction play a significant role[39].

Cost-231 Hata Model: Similar to the Okumura-Hata model, the Cost-231 Hata model provides path loss estimates based on distance, frequency, and antenna heights. It's widely used for urban and suburban environments and is known for its simplicity and ease of use[39][40].

Extended Hata Model (eHata): The eHata model is an extension of the Hata model that takes into account additional factors such as terrain variations, clutter types, and frequency. It provides more accurate predictions in scenarios with varying topography and building characteristics[38].

ITU-R P.1411-7 Model: The ITU-R P.1411-7 model considers different clutter types (urban, suburban, rural) and includes factors like building density, street width, and antenna heights. It's a comprehensive model suitable for various environments[41].

WINNER II Model: The WINNER II model offers a detailed approach, accounting for both macrocell and microcell environments. It considers parameters like building density, street layout, and antenna height to provide accurate path loss predictions[42].

COST 2100 Model: The COST 2100 model addresses a wide range of scenarios, including indoor, outdoor, and hybrid environments. It takes into account factors like wall penetration loss and can be customized for specific scenarios[43].

METIS Model: The METIS project developed advanced channel models that go beyond traditional approaches. These models account for spatial consistency, MIMO, beamforming, and dynamic scenarios. They provide a more accurate representation of real-world signal behavior[44].

3.3.2.2 5G mmwave propagation models

There are several channel propagation models that can be used for 5G mmwave to predict how wireless signals will propagate in different environments. Due to the unique characteristics of mmwave frequencies, these models often consider the effects of higher free space loss, atmospheric absorption, and sensitivity to obstacles. Here are a few commonly used channel propagation models for 5G mmwave:

3GPP TR 38.900 Urban Microcell and Urban Macrocell Models:

- This effort to offer channel models from 0.5-100 GHz depend on an adjustment of 3GPP's extensive exertion to improve replicas from 6 to 100 GHz in TR 38.900.
- The 3GPP (Third Generation Partnership Project) has defined channel models for mmwave frequencies in urban microcell and urban macrocell environments. These models consider various factors such as building geometry, street layout, and clutter density. The urban microcell model accounts for small cell deployments with shorter distances, while the urban macrocell model is suitable for larger cell sizes[45].

METIS Model:

The METIS project, mentioned earlier, also includes channel models that address the unique characteristics of mmwave frequencies. These models consider spatial consistency, beamforming, and dynamic scenarios to provide accurate predictions for mmwave propagation[44]. Addressed the demands of 5G specifications (such as broad frequency coverage, extensive bandwidth, massive MIMO, and precise polarization modeling). Conducted comprehensive channel measurements across a range of frequencies spanning 2GHz to 60GHz. Developed diverse channel modeling approaches, including map-based, stochastic, and hybrid models. The stochastic model, for instance, concentrated on scenarios like outdoor squares, indoor cafeterias, and indoor shopping malls.

MiWEBA Model:

- Tackled a range of obstacles: Including shadowing, spatial uniformity, dynamic environments, spherical wave representation, dual mobility Doppler effects, balance between diffuse and distinct reflections, and polarization considerations.
- Introduced a Quasi-deterministic channel model.
- Conducted channel measurements at the 60 GHz frequency.
- Emphasized scenarios like university campuses, street canyons, hotel lobbies, back-haul connections, and device-to-device interactions.[46]

ITU-R M Channel Models:

- Dealt with the challenges related to propagation loss and atmospheric attenuation in millimeter waves.
- Introduced advancements in antenna array technology and semiconductor technology.
- Outlined deployment scenarios that primarily targeted high data rate services in densely populated urban settings. These scenarios included indoor shopping malls, enterprise environments, residential settings, urban hotspots in squares or streets, and mobile connectivity within cities.[47]

NYU WIRELESS Channel Models:

- Carried out extensive urban propagation measurements across the 28/38/60/73 GHz frequency bands, encompassing both outdoor and indoor channels. These measurements are ongoing.
- Introduced three key areas for 5G mmwave channel modeling, which constitute minor adaptations or expansions of the current below 6GHz channel models as defined by 3GPP.
- Modeling of line-of-sight (LOS), non-line-of-sight (NLOS), and blockage scenarios, incorporating a squared exponential term.
- Broadband power delay profiles that encompass time clusters and spatial lobes, representing a straightforward extension to the existing 3GPP Small-Scale Channel Model (SSCM).
- A physics-based path loss model that utilizes existing 3GPP path loss equations, replacing the variable "floating" optimization parameter with a deterministic 1-meter "close-in" free space reference term. This replacement aims to offer a uniform and reliable definition of "path loss exponent" across various parties, scenarios, and frequencies.[48]

802.11 ad/ay Channel Models:

- Employed ray-tracing techniques to study indoor channels within the 60 GHz frequency band. The study encompassed scenarios such as conference rooms, cubicles, and living rooms.
- Introduced intra-cluster parameters, specifically addressing ray excess delay and the distribution of ray power.
- Presented models for human blockage, incorporating metrics like blockage probability and the attenuation caused by blockages[49].

5G mmwave Channel Model Alliance:

- Aims to facilitate the advancement of core research related to measuring, analyzing, identifying physical attributes, and statistically characterizing mmwave propagation channels.
- Organized into six cooperative working groups: Steering Committee, Modelling Methodology Group, Measurement Methodology Group, as well as groups dedicated to defining and parameterizing Indoor, Outdoor, and Emerging Usage Scenarios.
- Supported by the Communications Technology Research Laboratory housed within the National Institute of Standards and Technology (NIST).[50]

mmMAGIC:

- Unites prominent infrastructure vendors, significant European operators, top-tier research institutions and universities, measurement equipment suppliers, and a small and medium-sized enterprise (SME).
- Plans to conduct comprehensive radio channel measurements spanning the 6-100 GHz spectrum.
- Aims to create and confirm sophisticated channel models that will undergo rigorous validation and feasibility assessment for proposed concepts and systems. These models will also be instrumental in regulatory and standards contexts.[51]

3.3.3 Propagation Model Selections

The selection of appropriate propagation models plays a pivotal role in accurately predicting signal behavior and optimizing network design for distinct frequency bands. For the 5G sub-band (3.5GHz), the Cost 231-Hata path loss model was selected by the vendor of Ethio telecom. This well-established model takes into account factors such as frequency, distance, and the urban environment to estimate path loss accurately. By leveraging empirical data and accounting for various terrain characteristics, the Cost 231-Hata model aligns with the study's goal of assessing coverage, capacity, and cost performance in sub-band frequencies. Its applicability enables a comprehensive evaluation of signal propagation, aiding in informed decisions about base station placement and configuration.

Conversely, for the 5G mmwave (26GHz) scenario, the 3GPP TR 38.901 model is a fitting choice. Given the unique propagation characteristics of mmwave frequencies, this model encompasses a wide range of parameters including beamforming, blockage effects, and path loss in complex urban environments. Its incorporation reflects the study's emphasis on addressing the challenges and opportunities posed by mmwave propagation. The 3GPP TR 38.901 model facilitates the evaluation of coverage and capacity in scenarios where direct line-of-sight and blockage events significantly impact signal propagation. By employing this model, the thesis aims to provide insights into optimizing network deployment, ensuring effective coverage, and enhancing overall performance within the context of 5G mmwave deployments.

3.3.3.1 Technical Challenges in Millimeter Wave Channel Modeling

Millimeter wave (mmwave) communication introduces several technical challenges that need to be addressed for accurate channel modeling. These challenges arise due to the unique propagation characteristics of mmwave frequencies and their interactions with the environment[52]. Some of these challenges include:

Free Space Path Loss: Mmwave signals experience higher free space path loss compared to lower frequency signals. This results in a rapid decrease in signal strength as the

distance between the transmitter and receiver increases. Modeling this loss accurately is crucial for predicting signal coverage and link quality[53].

Atmospheric Attenuation: Mmwave signals are more susceptible to atmospheric absorption and attenuation. Factors like rain, fog, and humidity can significantly impact signal strength. Accurate modeling of these atmospheric effects is important for understanding signal degradation under different weather conditions[54].

Vegetation Attenuation: Foliage, trees, and other vegetation can cause signal attenuation in mmwave scenarios. The interactions between signals and foliage introduce additional loss and signal degradation. Modeling how signals penetrate vegetation and the resulting attenuation is important for designing outdoor mmwave networks[55][56].

Channel Sparsity: Mmwave channels exhibit a sparsity property, meaning that only a limited number of significant propagation paths contribute to signal reception. Capturing this sparsity accurately in channel models is essential for optimizing resource allocation and estimating channel capacity[57].

Blockage Effect: Mmwave signals are highly sensitive to obstacles such as buildings, walls, and human bodies. These obstructions can block or attenuate signals, leading to coverage gaps and degradation in signal quality. Modeling how blockages impact signal propagation is critical for designing reliable mmwave networks[58][59].

Beam Misalignment: Mmwave systems often use highly directional antennas and beamforming to establish links. However, the alignment of these narrow beams between the transmitter and receiver can be challenging, especially in mobile scenarios. Accurate modeling of beam misalignment effects is necessary for maintaining consistent connections.

Large-Scale Path Loss Models

Large-scale path loss models for millimeter wave signal strength prediction can be categorized into three primary groups [48]. These classifications encompass the Close-in (CI) model with a reference distance of 1 meter, the CI model incorporating a path loss

exponent that accounts for frequency or height (CIF and CIH models), and the Floating intercept (FI) path loss model, which is alternatively known as the ABG model due to its utilization of three parameters: alpha, beta, and gamma[60].

Close-in (CI) free space reference distance model

The Close-in (CI) free space reference distance model is a type of large-scale path loss model used to predict signal strength in millimeter wave communications. It is characterized by a reference distance of 1 meter, which represents a relatively close range between the transmitter and receiver. This model takes into account the attenuation of the signal over this short distance and uses it as a reference to estimate the path loss at other distances. The CI model assumes that the path loss increases with distance from the reference point, and it forms the basis for further variations of the model, such as the CIF and CIH models. The CI model's simplicity and the fact that it provides a basic estimate of path loss make it a useful tool for initial signal strength prediction in millimeter wave scenarios[61].

$$PL^{CI}(f_c, d3D)[dB] = FSPL(f_c, 1m) + 10n \log_{10}(d3D) + (\sigma)^{CI} \quad (3.4)$$

Where $(\sigma)^{CI}$ is the shadow fading (SF) that is displayed as a zero-mean Gaussian random variable with a standard deviation in dB, n is the path loss exponent (PLE) recognized by diminishing the fault of the measured data to $d3D$ less than 1m, $FSPL(f, 1 m)$ is the free space path loss (FSPL) at frequency f_c in GHz at 1 m.

3.3.4 Antenna Placement and Configuration

In the methodology section of a study comparing the coverage, capacity, and cost performance of 5G sub-band (3.5GHz) and 5G millimeter wave (26GHz) networks, the antenna placement and configuration would involve the following steps:

1. **Antenna Selection:** Determine the antennas to use in the study. The selected antenna beamforming antennas, depend on the network requirements and capabilities.
2. **Antenna Height:** Decide on the optimal height for the antennas. This is based on

factors such as the terrain, the desired coverage area, and the propagation characteristics of the frequencies being studied (3.5GHz and 26GHz). The antenna height is 25 meters for the sub-band (3.5GHz) and 10 meters for the mmwave.

3. Azimuth and Tilt Angles: Specify the azimuth and tilt angles for the antennas. Azimuth angle determines the horizontal direction of the antenna beam, while tilt angle controls the vertical coverage angle. These angles are adjusted to achieve the desired coverage objectives.

4. Antenna Distribution: Determine the placement of antennas within the study area. This involves selecting suitable locations for base stations or access points and ensuring an appropriate distribution to cover the target area effectively. Factors like building height, population density, and geographical features are considered during this process.

3.3.5 Coverage Evaluation Parameters

Coverage evaluation parameters in wireless communication systems like 5G are essential for assessing the quality and reach of the network. Two key frequency bands for 5G are the sub-6 GHz band (which includes 3.5 GHz) and the millimeter-wave (mmwave) band (which includes 26 GHz). The evaluation parameters for coverage in these bands typically include:

SS-RSRP (Serving Cell Reference Signal Received Power): SS-RSRP measures the received power of the reference signal from the serving cell. It's a fundamental parameter used to determine signal quality and cell selection. These parameters are often used in LTE and 5G networks to assess coverage quality.

Signal Strength (Received Signal Strength Indicator, RSSI): Signal strength measures the power level of the received signal at a specific location. It is often used to estimate coverage since stronger signals indicate better connectivity and coverage.

SS-RSRQ (Serving Cell Reference Signal Received Quality): SS-RSRQ considers both signal power and quality. It's the ratio of SS-RSRP to the interference and noise levels, providing insight into the received signal's overall quality.[62]

SINR (Signal-to-Interference-plus-Noise Ratio): SINR measures the ratio of the desired signal strength to the combined interference and noise. It's a key metric for assessing signal quality in the presence of noise and interference. A higher SNR indicates a more reliable signal, which is crucial for maintaining stable communication.

Table 3.1: Coverage requirements and Standard Signal Strength indicators of LTE[63]

Radio frequency Conditions	RSRP(dBm)	RSRQ(dB)	SINR(dB)
Excellent	≥ -80	≥ 10	≥ 20
Good	-80 to-90	-10 to -15	13 to 20
Midcell	-90 to -100	-15 to -20	0 to 13
Cell edge	≤ -100	≤ -20	≤ 0

3.3.6 Coverage Based Site Counts

Cellular Planning

The main objective of this section is to elucidate broader concepts within the realm of cellular planning, with the intention to assess and validate the strategy employed at this level. To commence, a pivotal assumption is made wherein cell dimensions remain consistent within a particular coverage area defined by specific parameter configurations. The use of a hexagonal cell structure is anticipated, in line with the concept of tri-sector station commonly adopted in real-world network cell architectures.

This geometry is favored for its ability to minimize overlap and gaps. Additionally, a standard handover ratio is defined for each cell size, but this approach has limitations when dealing with particularly large cell sizes. The size of the cells is determined by the layout of the site, and the cell radius is computed based on the design of each site, which may take the form of omni-directional, 2-sector, or 3-sector configurations.

For each variety of site configurations shown in the figure above, the site area is calculated as:

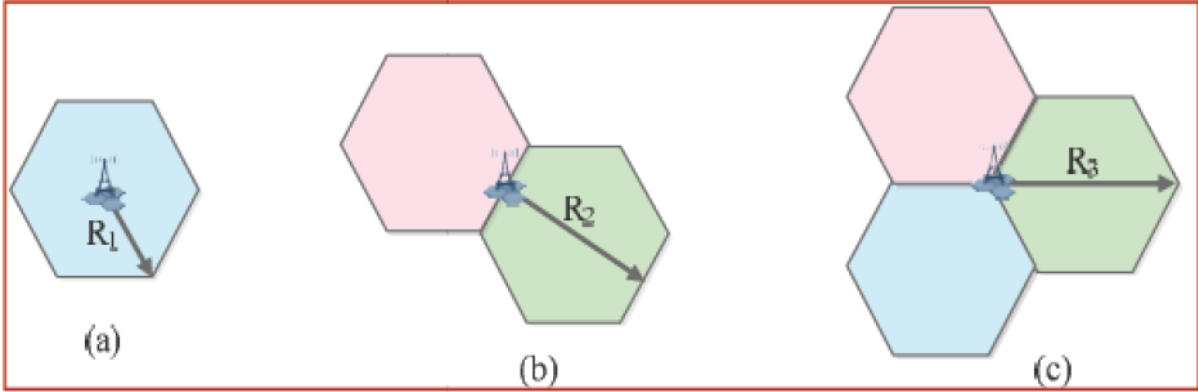

Figure 3.2: Type of site configurations (a) Omni-directional (b) Two-sector (c) Tri-sector[64]

For Omni-directional:

$$SA[KM^2] = 3/2\sqrt{3}[R_1]^2[KM] \quad (3.5)$$

For 2-Sector:

$$SA[KM^2] = \sqrt{3}[R_2]^2[KM] \quad (3.6)$$

For 3- Sector:

$$SA[KM^2] = 9/8\sqrt{3}[R_3]^2[KM] \quad (3.7)$$

Where; SA is denoting Site area. Finally, the site count based on Coverage is calculated as:

$$T_{NS} = T_{CA}/SA \quad (3.8)$$

Where; TNS is the total number of sites

SA is the site area

and TCA is the target coverage area.

3.4 Capacity Planning

This section focuses on utilizing user density, estimating busy-hour users, and data levels per month to determine the optimal number of base stations required for the 5G New Radio (NR) network.

Capacity planning is a pivotal step in crafting an efficient 5G New Radio (NR) network that meets user demands while maintaining superior service quality. This section outlines the methodologies employed to determine the optimal number of base stations required for the 5G sub-band (3.5GHz) and 5G mmwave (26GHz) frequency scenarios. Our approach capitalizes on user density (population density), estimating busy-hour users, and data consumption levels per month to accurately gauge the network's capacity requirements.

3.4.1 Capacity Calculation Based on Geographical Population

Capacity calculation based on geographical population density is an approach used to estimate the network capacity requirements for a wireless communication system in a specific geographic area, taking into consideration the distribution of population or users. This method is particularly useful for urban and suburban network planning, where user density can vary significantly across different regions. Here's how capacity calculation based on geographical population density works:

Population Density Data

Obtain data or estimates of population density in the target area. This data can be collected from census records, surveys, or other demographic sources. It quantifies the number of people or potential users in different geographic regions.

$$5G_{EMS} = TP * T_{EMS} * 5G_{EMS}(percent) * SA \quad (3.9)$$

Where;

5G_{EMS}: 5G expected mobile subscriber

TP: Total population per kilometer square

T_{EMS}: Total expected mobile subscriber

SA: Total selected area

User Behavior Analysis

Analyze the behavior of users in different geographic areas. Consider factors such as the density of mobile device usage, types of applications and services commonly used, and usage patterns (e.g., peak hours, special events).

Traffic Demand Estimation

Estimate the expected traffic demand in each region based on population density and user behavior analysis. This involves calculating the data traffic generated by users in each area, considering factors like voice calls, video streaming, web browsing, and IoT device communications.

3.4.2 Network Capacity Evaluation and Performance Analysis

The evaluation of network efficiency is typically measured through metrics like throughput and SINR. In telecommunications, SINR serves as a metric for assessing network quality. It is defined as the ratio of the signal of interest's power to the combined sum of interference power (from all the other interfering signals) and background noise power. The SINR value is calculated using the subsequent formula.

$$SINR = P_{rsignal} / InterferenceSignal + NoisePower \quad (3.10)$$

Where;

P_r signal is received a power which is the desired signal

$$P_r = P_t * G_t * G_r / Pathloss \quad (3.11)$$

Where; P_t : is the transmitter power; G_t : is the transmitter antenna gain; G_r : is the receiver antenna gain.

Data Rate and Data Throughput Analysis

Data rate and data throughput are indicative of the network's ability to deliver data to users at different rates. Data rate refers to the speed at which data is transmitted, while data throughput represents the amount of data successfully delivered over a given time period. In our performance evaluation, we measure both metrics to assess the network's capacity to provide high-speed data services. This analysis takes into account the modulation schemes, coding rates, and resource allocation strategies employed by the network.

In the hypothetical scenario, it aligns with the Shannon channel capacity. The throughput can be derived using the formula for Shannon capacity. The Shannon capacity formula aims to encompass both the efficiency of system bandwidth and the effectiveness of SINR within the radio network. The formula for Shannon capacity, as stated in [65], is as follows:

$$C(bps) = BW \log_2(1 + SINR) \quad (3.12)$$

Where; C : is channel capacity(bps); BW: is the Channel bandwidth in Hz; SINR: is Signal interference plus noise ratio.

3.4.3 Capacity Requirements

The overall count of users: - The quantity of users holds significance in establishing the count of sites required to accommodate capacity. Forecasting user figures is a crucial preliminary step before initiating network planning, ensuring the network can handle forthcoming user expansion. It is therefore vital to comprehend the social and economic elements that impact user counts within a particular market and predict how these numbers might alter over the upcoming years. The subsequent presumptions are embraced in this investigation to underscore the comprehensive contribution of all elements essential for effective network capacity planning.

3.4.4 Data volume per month

Data volume per month is an accounting solution by which a user can buy a certain amount of data service. In the capacity estimation, the data service is expressed by a

certain amount of data volume per month per subscriber. The capacity planning can be ongoing by estimating the daily traffic of the busy hour traffic as a percentage.

Calculate the average total throughput per subscriber@ Busy Hour (BH):

Average throughput per month

First step: Calculate the average total throughput per subscriber@ Busy Hour (BH):

Average throughput per month

$$BusyHour(Kbps) = (Monthlypackage * 8bit/byte) / Numofdays * Time(seconds) * BHratio \quad (3.13)$$

Second step: Calculate 5G new radio aggregate throughput or data rate

$$5Gthroughput(inMbps) = 10^{-6} \cdot \sum_{j=1}^J \cdot V_{layers}^{(j)} \cdot R_{MAX} \cdot (N_{PRB}^{BW_{j,y}} \cdot 12/T_s^y) (1 - OH^{(j)}) \quad (3.14)$$

Where:

J: number of aggregated component carriers in a band or band combination

Rmax: 948/1024

For the j-th CC (component carrier),

Vlayers(j) is the maximum number of layers

Qm(j): Maximum modulation order, Qm is 2 for QPSK, 4 for 16-QAM, 6 for 32-QAM, 8 for 256-QAM

f(j): Scaling factor, can take any value from 1/0.8/0.75/0.4;

y: 5G New radio numerology can take any value from 0 to 5;

Tsy: Average OFDM symbol duration in a subframe for y value,

NPRBBW(j),y: Maximum RB Allocation in bandwidth,

BW (j) with numerology (y),

BW (j) is UE-supported maximum Bandwidth in the given band or in band combinations.

RE (Resource elements) are come together into PRBs (Physical Resource Blocks). Each PRB consists of 12 Subcarriers. OH (j): Overhead which takes any of the following values in Table 3.3.

Table 3.2: Subcarrier spacing with maximum resource block allocation in bandwidth

BW(MHz)	Maximum RB	Freq. band(FR1)	Freq. band(Fr2)	(SCS)
50	270	✓		15 kHz
100	273	✓		30 kHz
100	135	✓		60 kHz
200	264		✓	60 kHz
400	264		✓	120 KHz

Table 3.3: Overhead values for FR1 and FR2

(OH)	FR1 DL	FR1 UL	Fr2 DL	FR2 UL
0.14	✓			
0.18			✓	
0.8		✓		
0.1				✓

3.4.5 Capacity Based Site Count

By using Equation DL and UL data rate can be calculated as;

$$Max.noofuserpersite(DL) = \frac{Aggregatecapacitythroughputpersite(DL)}{Av.throughputpersubscriberatBH} \quad (3.15)$$

$$Max.noofuserpersite(UL) = \frac{Aggregatecapacitythroughputpersite(UL)}{Av.throughputpersubscriberatBH} \quad (3.16)$$

3.5 Simulation

The simulation presents a pragmatic and structured approach to investigating complex systems. Within this study, simulation serves to explore the nominal planning phase of 5G network radio network planning, facilitated through the utilization of the Winprop tool. The simulation for 5G radio network planning encompasses activities such as link budget computation, propagation modeling via the terrain model, prediction of coverage, and estimation of capacity. This section delves into an exhaustive analysis of the planning process for radio network dimensioning, encompassing intricate parameter considerations, culminating in the evaluation of the outcomes from the planned network.

3.5.1 Site Survey

Identify suitable locations for base stations. Consider factors such as existing infrastructure, regulatory approvals, and the availability of power and backhaul connectivity. Optimize site placement to ensure adequate coverage overlap between cells while minimizing interference.

3.5.2 Digital Map

A digital map used for simulating a 5G mobile radio network is a computer-based representation of the geographical area where the network deployment and performance analysis will take place. This digital map serves as the foundational canvas upon which the simulation software creates a virtual environment to model real-world conditions. Here's how a digital map contributes to the simulation process:

Geographical Representation: The digital map accurately portrays the physical layout of the simulation area, including terrain features, buildings, roads, and other structures. It provides a visual representation of the real-world environment where the 5G network will be deployed.

Terrain Data: The map includes elevation data to reflect the variations in the landscape,

such as hills, valleys, and slopes. This information is crucial for accurate radio signal propagation modeling, as signal behavior is influenced by the terrain.

Obstacle Identification: The map identifies obstacles that could impact signal propagation, such as buildings, trees, and other structures. These obstacles can cause signal blockages and reflections, affecting coverage and capacity.

Coverage Prediction: The digital map helps the simulation software predict how signals will propagate in the area, considering factors like path loss, shadowing, and diffraction. This information is essential for predicting coverage areas and identifying potential dead zones.

Antenna Placement: The map assists in determining the optimal locations for placing base station antennas gNodeBs for optimal coverage and capacity. Antennas can be placed on buildings or towers within the simulation area.

Environmental Factors: The map may include information about urban density, land use, and other environmental factors that impact signal propagation and network performance.

Visualization: The digital map provides a visual interface that allows researchers and engineers to observe simulation results through coverage maps, signal strength plots, and other visual representations.

Parameter Configuration: The map helps in configuring simulation parameters based on the specific characteristics of the simulation area, such as antenna heights, tilt angles, and power settings.

3.5.3 Simulation Work Flow

Simulation of a 5G mobile radio network using WinProp involves creating a virtual environment to model the behavior and performance of the network in a controlled and computationally efficient manner. WinProp is a widely used radio propagation modeling software that allows for the accurate prediction of signal propagation, coverage, interference, and other network parameters. Here's an overview of how the simulation process

works:

Network Design and Configuration: The simulation begins by designing the network layout, which includes placing base stations (eNodeBs/gNBs), antennas, and other network components. Parameters such as antenna height, tilt, azimuth, power, and frequency bands are configured based on real-world scenarios.

Terrain and Environment Modeling: WinProp incorporates terrain data and environmental features such as buildings, trees, and obstacles to create a realistic representation of the propagation environment. This is crucial for accurately predicting signal behavior.

Path Loss and Propagation Modeling: The software employs advanced path loss models (like COST 231-Hata or 3GPP models) to estimate signal attenuation over distance. These models consider factors like frequency, distance, antenna characteristics, and environment to predict how signals propagate through the simulation area.

Signal Strength Prediction: WinProp calculates signal strength at various points in the simulation area, allowing you to visualize coverage patterns and areas of weak or strong signal quality.

Interference Analysis: The simulation also considers interference from neighboring cells, which can impact network performance. Interference analysis helps in identifying potential areas of poor service quality.

Capacity Estimation: By modeling user distributions and traffic patterns, the simulation predicts the network's capacity in terms of the number of users that can be supported in different areas.

Data Throughput and Quality Prediction: Based on signal strength, interference, and capacity estimates, WinProp can predict data throughput and quality metrics like SINR (Signal-to-Interference-plus-Noise Ratio) for different locations.

Result Analysis: Simulation results are presented through coverage maps, plots, and statistical data. These outputs help assess network performance, identify coverage gaps, and optimize network design parameters.

3.6 Radio Optimization

This section focuses on the optimization strategies employed to enhance the performance of the 5G mobile radio network. Optimization is a vital process in ensuring that a 5G mobile radio network delivers optimal performance, catering to the evolving demands of users and applications. This section outlines the methodologies employed to optimize the network's coverage, capacity, and overall performance for both the 5G sub-band (3.5GHz) and 5G mmwave (26GHz) frequency scenarios.

3.6.1 Azimuth Optimization

Azimuth optimization involves optimizing the horizontal orientation of antennas to enhance coverage and minimize interference. By carefully adjusting azimuth angles, we ensure that antennas are pointing in the direction of high user concentration, enhancing signal strength and quality. Azimuth optimization also addresses potential coverage gaps and ensures that users within a given area experience seamless connectivity.

3.6.2 Tilt Adjustment

Tilt adjustment focuses on optimizing the vertical inclination of antennas to achieve optimal coverage across different geographical terrains. By adjusting the tilt angle, we optimize signal propagation for users located at varying heights, such as those in tall buildings or low-lying areas. Tilt adjustment enables us to mitigate signal blockage and shadowing effects, thereby improving overall network coverage and user experience.

3.7 Techno-economic analysis of 5G mobile networks

Techno-economic analysis of 5G mobile network coverage, capacity, and cost performance comparison of two different frequency bands, specifically 3.5GHz and 26 GHz, involves evaluating the technical and economic aspects of deploying and operating these networks. This analysis is important for network operators and decision-makers to understand the

trade-offs between coverage, capacity, and cost when deploying 5G infrastructure.

CAPEX and OPEX: CAPEX includes the initial investment in infrastructure, equipment, and spectrum licensing. OPEX includes ongoing operational costs like energy consumption, maintenance, and regulatory compliance.

OPEX

Energy Consumption Cost:

$$EnergyCost = TotalEnergyConsumption * CostPerUnitOfEnergy \quad (3.17)$$

Maintenance and Repairs Cost:

$$MaintenanceCost = No.OfBSAnnualMaintenanceCostPerBS \quad (3.18)$$

Depreciation: Depreciation accounts for the gradual loss of value of assets over their useful life, affecting the net cash flow calculation.

TCO: The total cost of ownership encompasses both CAPEX and OPEX, giving a holistic view of the costs associated with the network.

$$TCO = CAPEX + OPEX + Depreciation \quad (3.19)$$

Net Cash Flow: This is the cash inflow generated by the project after accounting for operational costs and depreciation.

$$NetCashFlow = TotalCashInflows - TotalCashOutflows \quad (3.20)$$

Cumulative cash: flow represents the running total of net cash flow over a series of periods.

ROI: ROI measures the profitability of the investment relative to the capital invested. A higher ROI indicates a more favorable investment.

$$ROI = (NetProfit/TotalInvestment)100 \quad (3.21)$$

$$NetProfit = AnnualRevenue - OPEX - Depreciation \quad (3.22)$$

Payback Period: The payback period signifies how long it takes to recover the initial investment. A shorter payback period is generally more favorable.

$$PaybackPeriod = TotalInvestment/AnnualCashFlow \quad (3.23)$$

Sensitivity Analysis: NPV accounts for the time value of money and helps assess the project's financial viability over time.

Net Present Value (NPV):

$$NPV = \sum (CashFlow_t / (1 + DiscountRate)^t) \quad (3.24)$$

Cost-Benefit Analysis: The cost-benefit ratio compares the net present value of benefits to the net present value of costs, offering insights into the project's overall desirability.

$$CostBenefitRatio = NetPresentValueBenefits/NetPresentValueCosts \quad (3.25)$$

Infrastructure Costs: This includes expenses related to base station deployment and site acquisition. The number of base stations and sites determines the coverage and capacity of the network.

Total Base Station Cost:

$$TotalCost = NumberOfBaseStationsCostPerBaseStation \quad (3.26)$$

Site Acquisition Cost:

$$SiteAcquisitionCost = NumberOfSitesCostPerSite \quad (3.27)$$

Spectrum Licensing Costs: Acquiring spectrum for the desired frequency bands involves a cost. This cost can impact the overall project budget.

$$SpectrumCost = BandwidthCostPerMHzLicenseDuration \quad (3.28)$$

Equipment Costs: Base station equipment and user devices contribute to the initial

investment. The number of users and base stations influences costs.

$$BSEquipmentCost = No.BSCostPerBSEquipment \quad (3.29)$$

Revenue Generation: ARPU indicates the average revenue earned per user. It's an essential metric for assessing the potential profitability of the network.

Average Revenue per User (ARPU):

$$ARPU = TotalRevenue/NumberOfSubscribers \quad (3.30)$$

Chapter 4

Deployment Scenarios and Methodology

4.1 Deployment Scenario

4.1.1 Geographical Area

The selection of Bole Airport in Addis Ababa, Ethiopia, as the site for conducting a comprehensive site survey for the study of 5G mobile radio networks, encompassing both the sub-band (3.5GHz) and 5G mmwave (26GHz) frequency bands, is marked by careful consideration and strategic reasoning. This choice is anchored in the airport's status as a prominent communication hotspot and its remarkable daily foot traffic, which exceeds 20,000 passengers[66].

The designated area, a rectangular zone measuring 1.2 km by 1.7 km in front of the airport, translating to a 2 square kilometer space, enhances the precision of this site selection. This chosen area encapsulates a dynamic microcosm of urban connectivity demands.

Furthermore, the presence of international hotels, the Millennium Hall, and embassies in the selected vicinity enhances the site's relevance and significance, augmenting the richness of data and insights that can be gleaned. This comprehensive site survey holds the potential to offer valuable insights into the intricate interplay of coverage, capacity, and cost performance for both frequency scenarios, thus contributing to a deeper understanding of 5G network deployment strategies.

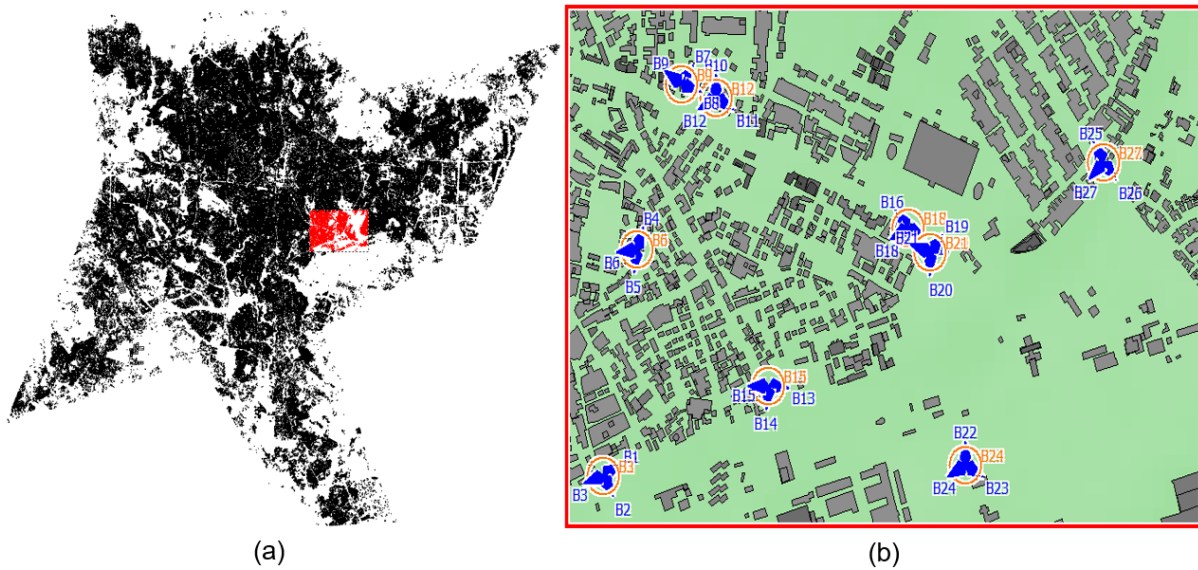

Figure 4.1: (a) Addis Ababa Digital map (b) Selected area with existing base station

4.1.2 Network Topology

The choice of network topology for the deployment scenario of 5G sub-band (3.5GHz) and 5G mmwave (26GHz) networks depends on various factors, including the specific goals of the deployment, the geographical area, user density, and available infrastructure. Here are common network topologies:

Hierarchical Cell Structure

Description: The hierarchical cell structure involves the use of multiple cell layers, typically consisting of macro cells, micro cells, and small cells. This approach is especially suitable for urban and densely populated areas where coverage and capacity are essential.

Cell Types:

Macro Cells: Macro cells are the largest and provide broad coverage over a wide area. They typically operate in the sub-6GHz bands like the 3.5GHz sub-band and can cover several kilometers.

Micro Cells: Micro cells are smaller cells with a more limited coverage area than macro cells. They typically operate in the 26GHz frequency band and can cover a few hundred

meters.

Micro cells are typically deployed at street level, on lampposts, or buildings. They use highly directional antennas to focus the signal in very specific directions. This helps to reduce interference and improve capacity.

Micro cells are well-suited for providing high-capacity coverage in densely populated areas, such as airports, sports stadiums, and concert venues. They can also be used to provide coverage in areas where macro cells cannot reach, such as inside buildings or behind hills.

Small Cells: Small cells are deployed at street level, on lampposts, or buildings, and they operate in both sub-6GHz and mmwave bands, depending on the capacity and coverage requirements. Small cells are closely spaced to provide high-capacity coverage in densely populated areas.

Macro cells in the 5G sub-band (3.5GHz) offer wide coverage suitable for suburban and urban areas, balancing coverage and capacity. Micro cells in 5G mmwave (26GHz) are small-scale, high-capacity cells ideal for dense urban environments, addressing intense data demands with smaller coverage areas.

Use Case: This hierarchical structure allows for seamless handovers between different cell layers, ensuring that users experience continuous connectivity while optimizing capacity and coverage based on their location and traffic demands.

4.1.3 Frequency bands

In Ethiopia, the regulatory authority has chosen to allocate and deploy 5G in the sub-band of 3.5GHz, aligning with global trends in using sub-6GHz frequencies for 5G networks to provide widespread coverage and penetration capabilities. However, they have not selected 5G mmwave frequencies for deployment. The suggestion to consider the 26GHz mmwave band, by ITU-R region recommendations, underscores the potential for using higher-frequency mmwave spectrum for high-capacity 5G applications, particularly in dense urban areas.

4.2 Methodology

4.2.1 Requirements

The planned average throughput per user for 5G networks varies based on frequency band, network setup, and deployment. In the sub-band (3.5 GHz) band, the average throughput per user is 40 Mbps for downlink and 10 Mbps for uplink. In mmwave (26 GHz) bands, 5G can deliver much higher throughput, 100 Mbps for downlink and 25 Mbps for uplink per user.

4.2.2 Radio Link Budget Calculation

Chapter 3 is dedicated to the meticulous process of link budget calculation for the network. This process involves a thorough analysis of path loss, the incorporation of antenna gains, and careful consideration of multiple influencing factors to precisely ascertain the requisite signal strength for ensuring dependable communication.

Transmitter Power

5G Sub-band (3.5GHz):

The transmitter power for 5G sub-band deployments in the 3.5GHz range typically ranges from around 10 watts (40 dBm) for small cells to several tens of watts (e.g., 60-70 dBm) for macro cells or base stations. 5G Sub-band(3.5GHz) used 10 watts (40 dBm) for Urban Macro deployment. These power levels cover larger geographic areas and provide reliable coverage in urban, suburban, and rural environments.

5G mmwave (26GHz):

5G mmwave deployments in the 26GHz range operate at much higher frequencies and typically require higher transmitter power to compensate for signal attenuation and propagation challenges. Transmitter power for mmwave base stations can range from several tens of watts (e.g., 40-50 dBm) to even over 100 watts (e.g., 50-60 dBm). 5G mmwave(26GHz)

used 40 watts (46 dBm) for Urban Micro deployment. Higher power is often needed to overcome signal blockage by obstacles and to provide the desired coverage in dense urban areas.

Path loss Models

COST 231 Model (for 5G Sub-band at 3.5GHz):

COST 231 is a widely used path loss model for estimating signal propagation in cellular networks. However, it was primarily developed for earlier generations of cellular networks like 2G and 3G. While it may be used as a starting point for path loss estimation in the 3.5GHz sub-band, 5G networks often employ more advanced and accurate models that take into account the specific characteristics of 5G deployments, including higher frequencies and beamforming.

3GPP TR 38.901 Model (for 5G mmwave at 26GHz):

3GPP (3rd Generation Partnership Project) is a standards organization that defines specifications for mobile telecommunications, including 5G. TR 38.901 is part of the 3GPP standard that provides guidelines for path loss modeling in the mmwave frequency range, including 26GHz. This model takes into account the unique propagation characteristics of mmwave frequencies, which include high atmospheric absorption and susceptibility to blockage by obstacles. It provides more accurate path loss predictions for mmwave-based 5G networks, considering factors like antenna patterns and beamforming.

Antenna Gain

5G Sub-band (3.5GHz):

For 5G deployments in the sub-band at 3.5GHz, antennas often have moderate to high gain, depending on the specific use case and deployment scenario. Typical base station antennas for macrocells in urban or suburban environments may have gains in the range of 14-18 dBi.

5G mmwave (26GHz):

In the mmwave frequency range, antennas tend to have higher gains to compensate for the increased free space path loss at these frequencies. mmwave base station antennas may have gains ranging from 20 dBi to 30 dBi or even higher. Due to the directional nature of mmwave signals and beamforming technologies, these antennas are designed to create highly focused beams to establish communication with user equipment.

Propagation Characteristics in 3.5GHz and 26GHz Bands

Propagation Characteristics:

Line of Sight (LOS) Conditions: Describe LOS conditions and their characteristics, emphasizing their importance for signal propagation in wireless networks. Discuss how LOS conditions are more prevalent at lower frequencies, such as 3.5GHz. Explain how LOS conditions contribute to strong and stable signal propagation, making them advantageous for network deployment.

Non-Line of Sight (NLOS) Conditions: Define NLOS conditions and their impact on signal propagation. Highlight the challenges NLOS conditions pose, including signal attenuation, multipath interference, and fading. Explain that NLOS conditions are more common in mmwave bands, such as 26GHz, due to their susceptibility to blockage by obstacles.

Deployment Considerations: Discuss the implications of LOS and NLOS conditions for the deployment of 5G sub-band (3.5GHz) and 5G mmwave (26GHz) networks.

Address how NLOS conditions in the 3.5GHz band can provide reliable coverage and penetration, even in LOS scenarios to some extent. Explain the challenges posed by LOS conditions in the mmwave band (26GHz) and the need for advanced technologies, such as beamforming and massive MIMO, to overcome these challenges.

In the subsequent section, we will execute the link budget calculation using Excel and record the results in Table 4.1(5G sub-band(3.5GHz) and 4.2(5G mmwave(26GHz).

Table 4.1: 5G sub-band(3.5GHz) Radio link budget

Parameters	Downlink/Uplink Budget Variable
Morphology	Urban
Duplex mode	TDD/TDD
User environment	Outdoor
System bandwidth (MHz)	100/100
Frequency band (MHz)	3500/3500
Cell edge rate (Mbps)	40/10
Max number of resource block (KHz)	273/273
MIMO Scheme	4x4/4x4
Tx output power (dBm)	A = 35
Tx antenna gain (dBi)	B = 8
TX cable and connector loss (dB)	C = 2
Transmitter body loss (dB)	D
EIPR per subcarrier (dBm)	E=A+B-C-D
UE noise figure (dB)	F = 9
Subcarrier spacing (kHz)	I = 30
Subcarrier	J = 12
PRB size (kHz)	G=I*J
Thermal noise (dB)	L=KBT
Receiver noise floor (dBm)	M=F+L
SINR (Linear)	$N = \text{Factor } B * (2^{(\text{Datarate}/\text{Factor}A)} - 1)$
SINR (dB)	O=10*log N
Receiver sensitivity (dBm)	P=M+O
Control channel overhead (dB)	Q = 0.14
Rx antenna gain (dB)	R = 0
Body loss (dB)	S
Shadowing fading loss (dB)	T = 5
Interference margin (dB)	V = 5
MAPL (dB)	MAPL=E-P-Q+R-S-T-V
Cell radius(KM)	0.355

Table 4.2: 5G mmwave(26GHz) Radio link budget

Parameters	Downlink/Uplink Budget Variable
Morphology	Urban
Duplex mode	TDD/TDD
User environment	Outdoor
System bandwidth (MHz)	400/400
Frequency band (MHz)	26000/26000
Cell edge rate (Mbps)	100/25
Max number of resource block (KHz)	264/264
MIMO Scheme	4x4/4x4
Tx output power (dBm)	A = 46
Tx antenna gain (dBi)	B = 16
TX cable and connector loss (dB)	C = 2
Transmitter body loss (dB)	D
EIPR per subcarrier (dBm)	E=A+B-C-D
UE noise figure (dB)	F = 7
Subcarrier spacing (kHz)	I = 120
Subcarrier	J = 12
PRB size (kHz)	G=I*J
Thermal noise (dB)	L=KBT
Receiver noise floor (dBm)	M=F+L
SINR (Linear)	$N=Factor B*(2^{(Datarate/Factor.A)} - 1)$
SINR (dB)	O=10*log N
Receiver sensitivity (dBm)	P=M+O
Control channel overhead (dB)	Q = 0.18
Rx antenna gain (dB)	R = 0
Body loss (dB)	S = 3
Shadowing fading loss (dB)	T = 4
Interference margin (dB)	V = 2
MAPL (dB)	MAPL=E-P-Q+R-S-T-V
Cell radius(KM)	0.190

4.2.3 Coverage Calculation

Use the link budget calculations to determine the coverage area for each base station. This helps you understand the range of each cell.

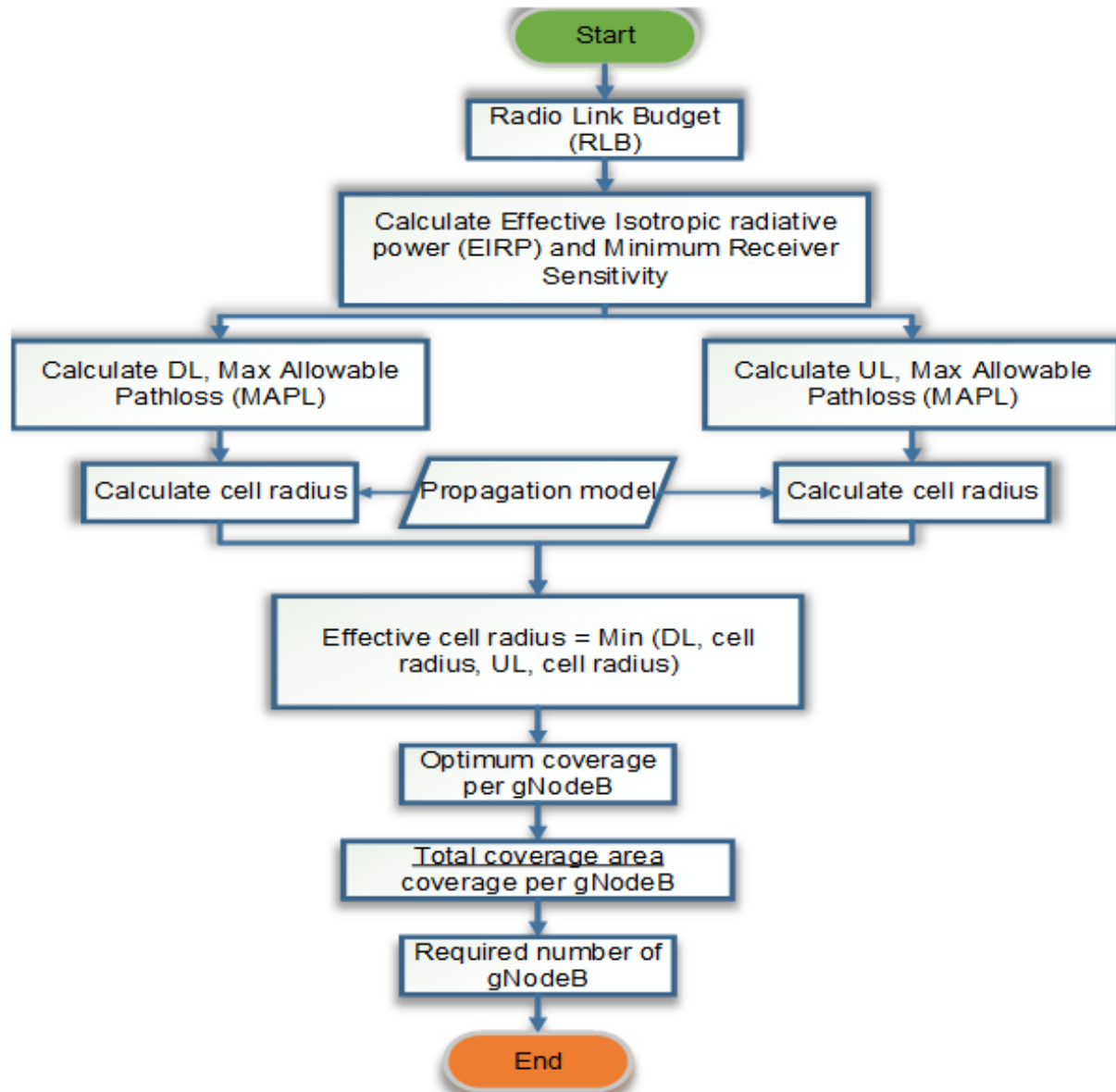

Figure 4.2: Coverage Dimensioning Flow Chart

Then, calculate the path loss value with the following equation

$$\text{Pathloss (dBm)} = \text{gNodeB transmit power (dBm)} - 10 \log_{10} (\text{subcarrier quantity}) + \text{gNodeB antenna gain (dBi)} - \text{gNodeB cable loss (dB)} - \text{penetration loss (dB)} - \text{foliage loss (dB)} - \text{body block loss (dB)} - \text{interference margin (dB)} - \text{rain/ice margin (dB)} - \text{slow fading margin (dB)} + \text{UT antenna gain (dB)} - \text{thermal noise figure (dBm)} - \text{UT noise figure}$$

(dB) – demodulation threshold SINR (dB)[38]

$$PL = 32.4 + 21 \log_{10}(d_{3D}) + 20 \log_{10}(fc) \quad (4.1)$$

Then find the radius from the above equation

$$d_{2D} = \sqrt{10^{(PL-32.4-20\log_{10}(fc)/10.5)}} - (h_{BS} - h_{UT}) \quad (4.2)$$

Table 4.3: Indicates the summary of the parameters and cell radius of sub-band(3.5GHz)

Parameter	DL	UL
gNodeB Antenna Height (m)	25	25
UE Antenna Height (m)	1.5	1.5
Frequency in MHz	3500	3500
MAPL (dB)	126.869	128.869
Cell radius(Km)	0.355	0.404
Effective cell radius (Km)	0.355	

Table 4.4: Indicates the summary of the parameters and cell radius of 5G mmwave(26GHz)

Parameter	DL	UL
gNodeB Antenna Height (m)	10	10
UE Antenna Height (m)	1.5	1.5
Frequency in MHz	26000	26000
MAPL (dB)	108.585	108.602
Cell radius(Km)	0.190467	0.190821
Effective cell radius (Km)	0.190467	

4.2.4 Coverage Based Site Counts of 5G sub-band(3.5GHz)

Now Suppose that all gNodeB's are three sectored sites (Tri-sector), the site area and the total number of coverage-based sites count are calculated by using Equation 3.7 and Equation 3.8 respectively as follows and get the radius from table 4.1 $R=0.355$ KM for DL and $R=0.404$ km for UL:

Coverage calculation for DL

$$SA[km^2] = 9/8\sqrt{3}[R_{sub}]^2[km] = 9/8\sqrt{3}[0.355km]^2 = 0.246km^2$$

The Coverage area of the Bole Sub City (part of the sub-city of Addis Ababa) is 0.246 Km².

Thus, the total number of sites for the target area is:

$$T_{NS} = T_{CA}/SA = 2/0.246 = 8.13 = \underline{8gNodeBs}$$

Coverage calculation for UL

$$SA[km^2] = 9/8\sqrt{3}[R_{sub}]^2[km] = 9/8\sqrt{3}[0.404km]^2 = 0.318km^2$$

The Coverage area of the Bole Sub City (part of the sub-city of Addis Ababa) is 0.318 Km².

Thus, the total number of sites for the target area is:

$$T_{NS} = T_{CA}/SA = 2/0.318 = 6.3 = \underline{6gNodeBs}$$

Hence, a total of 8(Eight) Coverage-based gNodeBs for DL and 6(six) for UL gNodeBs are required to deliver the radio coverage for the 2 Km² area around Bole airport for the 5G sub-band(3.5 GHz).

4.2.5 Coverage Based Site Counts of 5G mmwave(26GHz)

Now Suppose that all gNodeB's are three sectored sites (Tri-sector), the site area and the total number of coverage-based sites count are calculated by using Equations 3.7 and

3.8 respectively as follows and get the radius from table 4.2 $R=0.190$ KM for DL and $R=0.191$ km for UL:

Coverage calculation for DL

$$SA[\text{km}^2] = 9/8\sqrt{3}[R_{\text{mmwave}}]^2[\text{km}] = 9/8\sqrt{3}[0.190\text{km}]^2 = 0.0704\text{km}^2$$

The Coverage area of the Bole Sub City (which is one sub-City of Addis Ababa) is 0.0704 Km^2 .

Thus, the total number of sites for the target area is:

$$T_{NS} = T_{CA}/SA = 2/0.0704 = 28.57 = \underline{29gNodeBs}$$

Coverage calculation for UL

$$SA[\text{km}^2] = 9/8\sqrt{3}[R_{\text{mmwave}}]^2[\text{km}] = 9/8\sqrt{3}[0.191\text{km}]^2 = 0.0711\text{km}^2$$

The Coverage area of the Bole Sub City (which is one sub-City of Addis Ababa) is 0.0711 Km^2 .

Thus, the total number of sites for the target area is:

$$T_{NS} = T_{CA}/SA = 2/0.0711 = 28.13 = \underline{28gNodeBs}$$

Hence, a total of 29(Twenty nine) Coverage based gNodeBs for DL and 28(Twenty eight) Coverage based gNodeBs for UL are required to deliver the radio coverage for a 2 Km^2 area around Bole airport for 5G mmwave(26GHz).

4.2.6 Capacity Calculation

Estimate the expected traffic load in the target area. Consider factors like the number of users, types of services (e.g., video streaming, IoT devices), and expected data usage.

5G sub-band(3.5GHz) capacity Requirements

Throughput at cell-edge in downlink (DL) and uplink (UL)

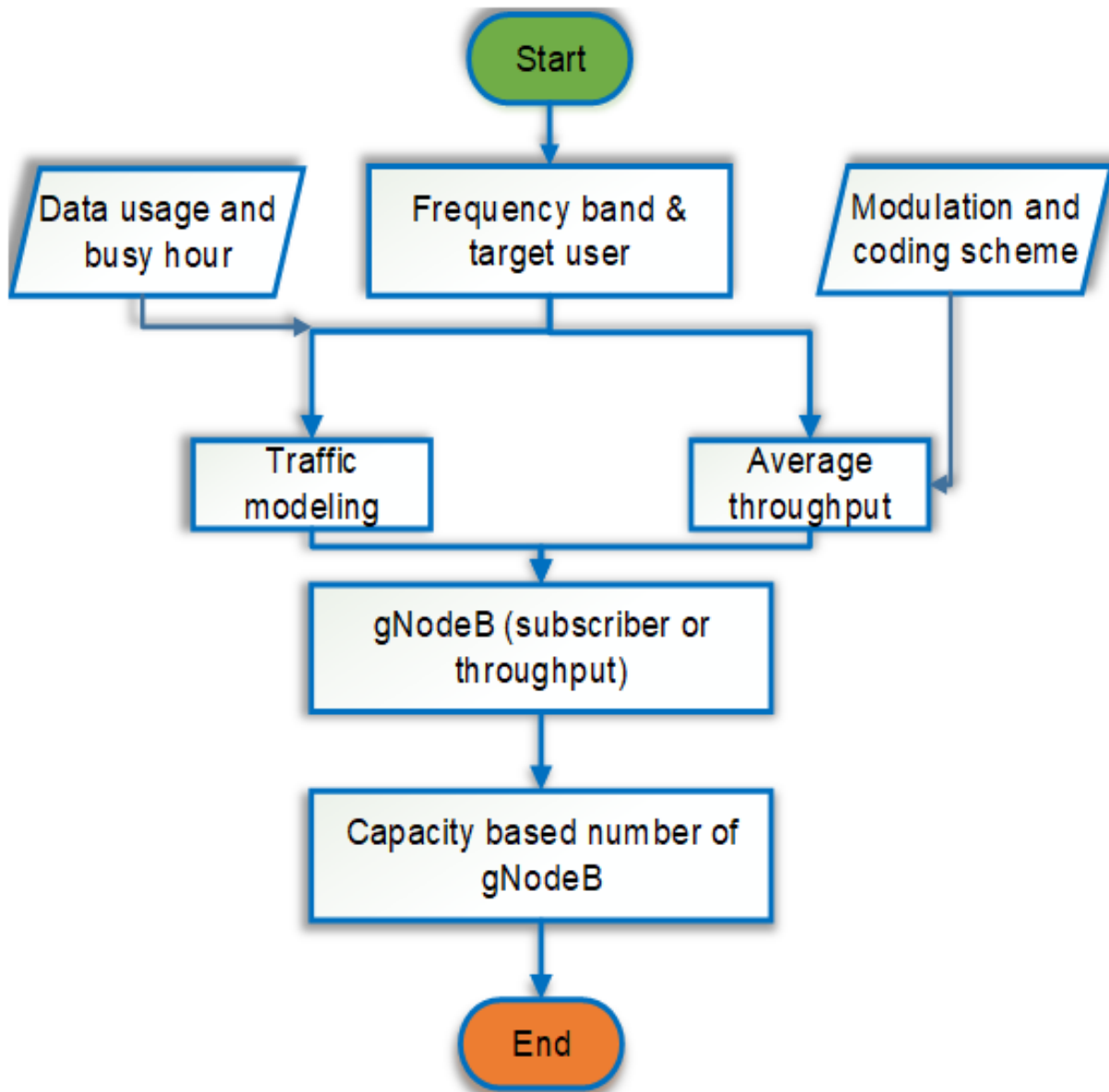

Figure 4.3: Capacity flow chart

Throughput at cell-edge design targets in the downlink and uplink are assumed to be 40 Mbps and 10 kbps respectively.

The assumption we are using in this thesis: -

- In the context of Addis Ababa, specifically in the Bole sub-city, the term "population density" refers to the measure of how many individuals reside within a given area of one square kilometer. In this case, the population density within the Bole sub-city is quantified as 3567 individuals per square kilometer in 2022.

By using the equation 3.9

$$5G_{EMS} = 3880 * 0.7 * 0.4 * 2 = 2172.8 = 2173 \text{ subscribers}$$

Data volume per month

Data volume per month is an accounting solution by which a user can buy a certain amount of data service. In the capacity estimation, the data service is expressed by a certain amount of data volume per month per subscriber. The capacity planning can be ongoing by estimating the daily traffic of the busy hour traffic as a percentage.

Now, calculate the peak 5G new radio capacity throughputs or data rate by using Equation 3.14. Accordingly; in this thesis design; consider the following values in Table 4.5.

Table 4.5: 5G sub-band(3.5GHz) Capacity parameters with its value

Parameters	Downlink	Uplink
Frequency	3.5 GHz	3.5 GHz
Bandwidth(MHz)	100MHz	100MHz
Overhead(OH)	0.14(DL)	0.08(UL)
Max. code rate(Rmax)	948/1024	948/1024
Number carriers(J)	1	1
Number of Layers (V)	4	4
Scaling factor/ signaled per band (f)	1	1
Max. number of Resource block	273	273
Sub-carrier per Resource block	12	12
Sub-carrier spacing	30KHz	30KHz
Average OFDM symbol duration (Ts)	$3.577 * 10^{-5}$	$3.577 * 10^{-5}$
Numerology(μ)	1	1
Bits per Symbol from modulation scheme(QM)	8	6

Hence, the aggregate capacity throughput per site or data rate from Equation 3.14 and Table 4.5 can be calculated as:

Downlink Data rate (in Mbps)

$$DL\ trh = 10^{-6} * 1 * 2 * 8 * 1 * (948/1024) * (273 * 12) * (14 * 2^1 / 10^{-3} (1 - 0.14))$$

$$DLtrh = 2337Mbps$$

Uplink Data rate (in Mbps)

$$UL\ trh = 10^{-6} * 1 * 2 * 6 * 1 * (948/1024) * (273 * 12) * (14 * 2^1 / 10^{-3} (1 - 0.08))$$

$$ULtrh = 1875Mbps$$

The maximum subscriber number per site is now calculated as:

Max.no of Subs per Site(DL)

=Aggregate capacity throughput per site or data rate (DL)/Total Av.throughput per Subscriber@BH)

$$= 2337/15.56 = 149\ subscribers$$

Aggregate capacity throughput per site or data rate (UL)/Total Av.throughput per Subscriber@BH)

$$= 1875/15.56 = 120\ subscribers$$

5G mmwave(26GHz) capacity Requirements

Throughput at cell-edge in downlink (DL) and uplink (UL)

Throughput at cell-edge design targets in the downlink and uplink are assumed to be 100 Mbps and 20 kbps respectively. 5G mmwave (millimeter wave) technology is a part of the fifth-generation (5G) mobile network technology. It operates at significantly higher frequencies compared to previous generations, enabling faster data transmission speeds and increased network capacity. In the context of our scenario, if 5G mmwave technology is introduced after five years, and the population increases by 4.3 % per year during that time, it suggests that the population of the area will grow steadily over the given period.

Calculate the number of subscribers using equation 3.9

$$5G_{EMS} = 4400 * 0.8 * 0.5 * 2 = 3520\ subscribers$$

First step: Calculate the average total throughput per subscriber@ Busy Hour (BH):

Average throughput per month calculated using equation 3.13 Total Av.throughput per

Subscriber@BH= 15.69 Mbps

Total Av.throughput per Subscriber@BH= 25.648 Mbps

Second step: Calculate 5G new radio aggregate throughput or data rate

Now, calculate the peak 5G new radio capacity throughputs or data rate by using equation 3.14. Accordingly; in this thesis design; consider the following values in Table 4.6.

Table 4.6: Capacity parameters with its value for 5G mmwave(26GHz)

Parameters	Downlink	Uplink
Frequency	26 GHz	26 GHz
Bandwidth(MHz)	400MHz	400MHz
Overhead(OH)	0.18(DL)	0.1(UL)
Max. code rate(Rmax)	948/1024	948/1024
Number carriers(J)	1	1
Number of Layers (V)	4	4
Scaling factor/ signaled per band (f)	1	1
Max. number of Resource block	264	264
Sub-carrier per Resource block	12	12
Sub-carrier spacing	120KHz	120KHz
Average OFDM symbol duration (Ts)	$3.577 \cdot 10^{-5}$	$3.577 \cdot 10^{-5}$
Numerology(μ)	3	3
Bits per Symbol from modulation scheme(QM)	8	6

Hence, the aggregate capacity throughput per site or data rate from Equation 3.14 and Table 4.6 can be calculated as:

Downlink Data rate (in Mbps)

$$DL \text{ trh} = 10^{-6} * 1 * 4 * 8 * 1 * (948/1024) * (264 * 12) * (14 * 2^3/10^{-3}(1 - 0.18))$$

$$DLtrh = 8610Mbps$$

Uplink Data rate (in Mbps)

$$UL\ trh = 10^{-6} * 1 * 4 * 6 * 1 * (948/1024) * (264 * 12) * (14 * 2^3 / 10^{-3} (1 - 0.1))$$

$$ULtrh = 6081Mbps$$

The maximum subscriber number per site is now calculated as:

Max.no of Subscribers per Site

=Aggregate capacity throughput per site or data rate (DL)/Total Av.throughput per Subscriber@BH)

$$DL = 8610 / 25.648 = 335 \text{ subscribers}$$

=Aggregate capacity throughput per site or data rate (UL)/Total Av.throughput per Subscriber@BH)

$$UL = 6081 / 25.648 = 237 \text{ subscribers}$$

Capacity Based Site Counts of 5G network

Capacity Based Site Counts of 5G sub-band(3.5GHz)

$$Cap.basedSitescount_{(DL)} = \frac{TotalSubscribernumberoftherequiredarea}{Max.noofSubsperSite_{(DL)}} \quad (4.3)$$

Capacity based Sites count(DL)

$$= 2173 / 149 = 14.34 = 14 \text{ gNodeBs}$$

Capacity based Sites count(UL)

$$= 2173 / 129 = 16.42 = 16 \text{ gNodeBs}$$

Capacity Based Site Counts of 5G mmwave(26GHz) Calculate using equation 3.15 and 3.16

Capacity based Sites count(DL)

$$= 3520 / 335 = 10.5 = 11 \text{ gNodeBs}$$

Capacity based Sites count(UL)

$$= 3520/237 = 14.8 = 15 \text{ gNodeBs}$$

4.2.7 Define the Number of Base Stations

Based on the capacity calculations and coverage requirements, determine how many base stations are needed to cover the target area effectively.

4.2.8 Optimum number of Base Station count by using Coverage and Capacity Table 4.7

Table 4.7: Optimum number of Base Station count by using Coverage and Capacity

Network type	Cov. DL	Cov. UL	Cap. DL	Cap. UL	Optimum
5G sub(3.5GHz)	8	6	14	16	16
5G mmwave(26GHz)	29	28	11	15	29

4.2.9 Techno-economic Analysis

Cost Planning

Step 1: Data Collection

Gather data related to network deployment costs, operational expenses, expected revenue, and subscriber growth projections.

Step 2: Cost Estimation

Calculate the initial capital expenditure (CapEx) for each network, including equipment costs, site acquisition, and installation. Calculate the operational expenditure (OpEx), which includes ongoing maintenance, power, and other operational costs.

Step 3: Revenue Estimation

Estimate the revenue generated by each network based on subscriber projections and pricing models.

Step 4: Cash Flow Projection

Create a cash flow projection for each network, incorporating CapEx, OpEx, and revenue over a specified time period.

Step 5: Discount Rate

Determine an appropriate discount rate, typically based on the cost of capital or an industry-specific rate.

Step 6: Net Present Value (NPV)

Calculate the NPV for each network using the following formula:

$$NPV = \text{Cash Flow} / (1 + \text{Discount Rate})^t$$

Where:

Cash Flow is the net cash flow for each year. Discount Rate is the chosen discount rate. t is the year of the cash flow.

Step 7: Internal Rate of Return (IRR)

Calculate the IRR using the cash flows and the following formula:

$$0 = \text{Cash Flow} / (1 + IRR)^t$$

Use numerical methods or financial software to find the IRR that makes the equation equal to zero.

Step 8: Payback Period

Determine the payback period, which is the time it takes for the cumulative cash flow to equal the initial investment. Calculate it by accumulating the cash flows year by year

until they cover the initial investment.

Step 9: Compare Results

Compare the NPV, IRR, and Payback Period for the 5G sub-band and 5G mmwave technologies. A positive NPV, a higher IRR, and a shorter payback period generally indicate better economic viability.

In Table 4.8, you would collect data related to the annual capital expenditures incurred to establish and expand the 5G mobile network. These values represent the financial investments made to build and launch the network infrastructure.

Table 4.8: CAPEX of 5G sub-band and 5G mmwave

CAPEX	5G sub-band(3.5GHz)	5G mmwave(26GHz)
Spectrum	2,000,000	3,000,000
Site Survey and Network design	11250	22500
New gNodeB	10500	21000
Cost related to base station	450000	900000
Co site installation	1500	3000
gNodeB implementation	150	300
Total (\$)	2,473,400	3,946,800

In Table 4.9, you would collect data related to the annual operating expenses associated with the 5G mobile network. These values represent the recurring costs required to keep the network operational and deliver services to customers.

Both CAPEX and OPEX are critical considerations in network planning and financial management. CAPEX reflects the upfront investments required to build the network, while OPEX represents the ongoing costs to ensure its smooth operation. Accurate data collection and analysis of both CAPEX and OPEX are essential for effective network planning, budgeting, and financial sustainability.

The payback period is a financial metric that indicates the time it takes for an investment to generate enough net cash flows to recover the initial investment cost. In your case, the

Table 4.9: OPEX of 5G sub-band and 5G mmwave

OPEX parameters	Distribution (%)	5G sub	5G mmwave
Network driven per site /year	60%	77716.71	155433.23
Network maintenance and operation	36%	362.75	725.5
Site rental	36%	4.72	9.4
License renewal			
Energy consumption	15%	153.11	306.22
Backhaul costs per site/year	9%	91.87	183.73
Business driven	4%	408.29	816.6
Marketing and sales (advertising)	20%	204.14	408.28
Billing and customer care	8%	81.65	163.3
Customer service related costs	6%	61.24	122.5
General Administration	6%	61.24	122.5
Total (\$)		79145.73	158291.47

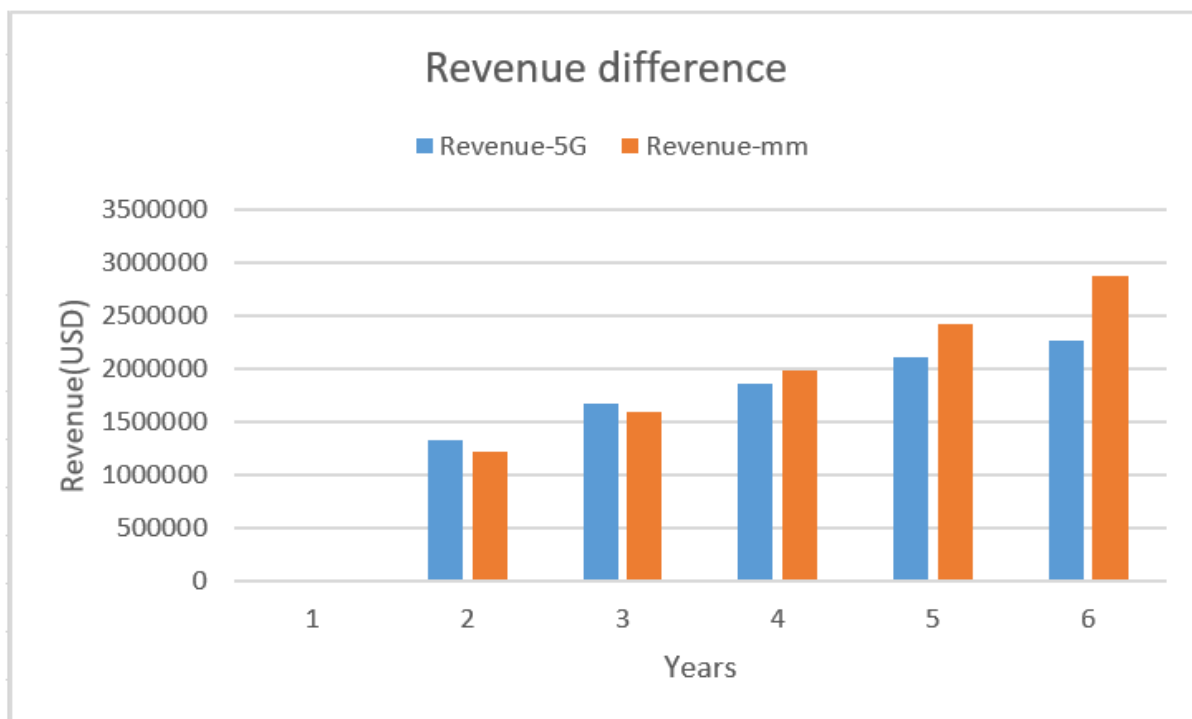

Figure 4.4: Revenue difference of 5G sub-band and 5G mmwave

Discount Rate	Study period					
	0	10%	11%	12%	13%	14%
Years	Investment year	1	2	3	4	5
Revenue-5G		\$ 1,332,576.00	\$ 1,668,240.00	\$ 1,868,240.00	\$ 2,112,000.00	\$ 2,262,016.00
Capex-5G	\$ (2,473,400.00)					
Revenue-mm		\$ 1,218,816.00	\$ 1,588,608.00	\$ 1,988,352.00	\$ 2,419,200.00	\$ 2,883,456.00
Capex-mm	\$ (3,946,800.00)					
Opex-5G		\$ (79,145.73)	\$ (87,851.77)	\$ (98,393.98)	\$ (111,185.19)	\$ (126,751.12)
Opex-mm		\$ (158,291.47)	\$ (175,703.53)	\$ (196,787.95)	\$ (222,370.39)	\$ (253,502.24)
Cash out-5G	\$ (2,473,400.00)	\$ (79,145.73)	\$ (87,851.77)	\$ (98,393.98)	\$ (111,185.19)	\$ (126,751.12)
Net Cash-5G	\$ (2,473,400.00)	\$ (1,219,969.73)	\$ 1,580,388.23	\$ 1,769,846.02	\$ 2,000,814.81	\$ 2,135,264.88
Net Cash-mm	\$ (3,946,800.00)	\$ 1,060,524.53	\$ 1,412,904.47	\$ 1,791,564.05	\$ 2,196,829.61	\$ 2,629,953.76
CCF-5G	\$ (2,473,400.00)	\$ (3,693,369.73)	\$ (2,112,981.50)	\$ (343,135.48)	\$ 1,657,679.33	\$ 3,792,944.21
CCF-mm	\$ (3,946,800.00)	\$ (2,886,275.47)	\$ (1,473,371.00)	\$ 318,193.05	\$ 2,515,022.66	\$ 5,144,976.41
DCF-5G	\$ (2,473,400.00)	\$ (1,109,063.40)	\$ 1,306,105.98	\$ 1,329,711.51	\$ 1,366,583.43	\$ 1,325,831.49
DCF-mm	\$ (3,946,800.00)	964113.2099	\$ 1,167,689.64	\$ 1,346,028.58	\$ 1,500,464.18	\$ 1,632,994.37
NPV-5G	\$ 1,745,769.02					
NPV-mm	\$ 2,664,489.99					
IRR(%)-5G	25%					
IRR(%)-mm	30%					
PBP-5G Sub(Years)	3.17					
PBP-mm(years)	2.82					

Figure 4.5: Overall calculation of Techno-economic Analysis of 5G sub-band and 5G mmwave

payback period for 5G sub-band (3.5GHz) is 3.17 years, while for 5G mmwave (26GHz), it is 2.82 years. This means that the investment in 5G mmwave technology is expected to recover its initial costs more quickly, in 2.82 years, compared to the 3.17 years needed for the 5G sub-band technology. A shorter payback period is generally favorable, as it indicates a quicker return on investment.

Chapter 5

Simulation Results and Performance Comparisons

This chapter focuses on the simulation methodologies used and the analysis of the results obtained from the simulations for both 5G sub-band (3.5GHz) and 5G mmwave (26GHz) frequency scenarios.

5.1 Simulation Results

Involve a series of carefully structured stages to comprehensively assess network performance across different frequency bands:

5.1.1 Simulation Configurations using Winprop

WinProp is a comprehensive radio wave propagation modeling and simulation tool used for various wireless communication systems.

Here are the basic steps for configuring 5G networks in WinProp:

Project Setup: Create a new project or open an existing one if you have already set it up. Define the geographical area for your simulation by specifying the region of interest (ROI), including the size, shape, and terrain information.

Propagation Models: Configure the propagation models to be used for your 5G simulation. WinProp supports various propagation models such as ray tracing, ray launching, and ray bundle methods, depending on your specific needs and the available data.

Antenna Configuration: Define the antenna characteristics for both the transmitter (eNodeB or gNB) and receiver (UE) sides. You'll need to specify antenna types, gains, radiation patterns, and positions.

Base Station Deployment: Place the 5G base stations (eNodeBs or gNBs) within the ROI. You can configure their locations, heights, and other parameters.

Frequency Bands and Channel Models: Define the frequency bands and channel models relevant to your 5G network simulation. Consider factors like bandwidth, carrier frequency, and channel characteristics.

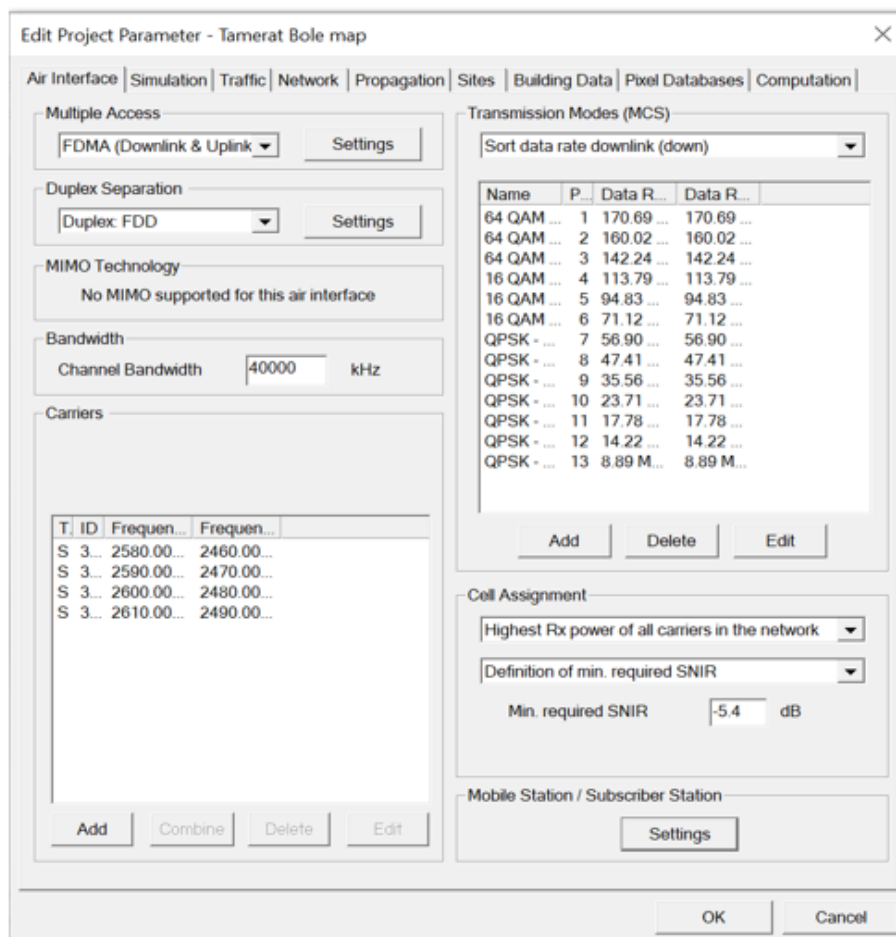

Figure 5.1: Configure the parameter on Winprop simulator of 4G-Advance

Propagation Analysis: Run the propagation analysis simulation to calculate signal strength, interference, and other relevant metrics. You may need to set up specific simulation scenarios to capture different aspects of your 5G network, such as coverage analysis, capacity analysis, or interference analysis.

Data Collection and Analysis: Collect simulation results and analyze them using WinProp's tools and visualization capabilities. This step involves examining metrics like signal-to-noise ratio (SNR), signal-to-interference-plus-noise ratio (SINR), and others.

Optimization and Fine-Tuning: Based on the analysis results, you may need to optimize your 5G network configuration by adjusting parameters such as antenna heights, positions, or power levels.

Reporting: Generate reports and visualizations to document your simulation results and findings.

5.1.2 4G-Advanced (2.6GHz) As Benchmark

The initial step involves simulating a 4G-Advanced network operating at 2.6GHz with 40MHz bandwidth, serving as a benchmark for evaluating subsequent 5G simulations. This benchmark provides a basis for understanding coverage, capacity, and performance metrics that can be achieved in an advanced 4G network scenario with existing 9 NodeBs refer from Figure 5.1 and 5.2.

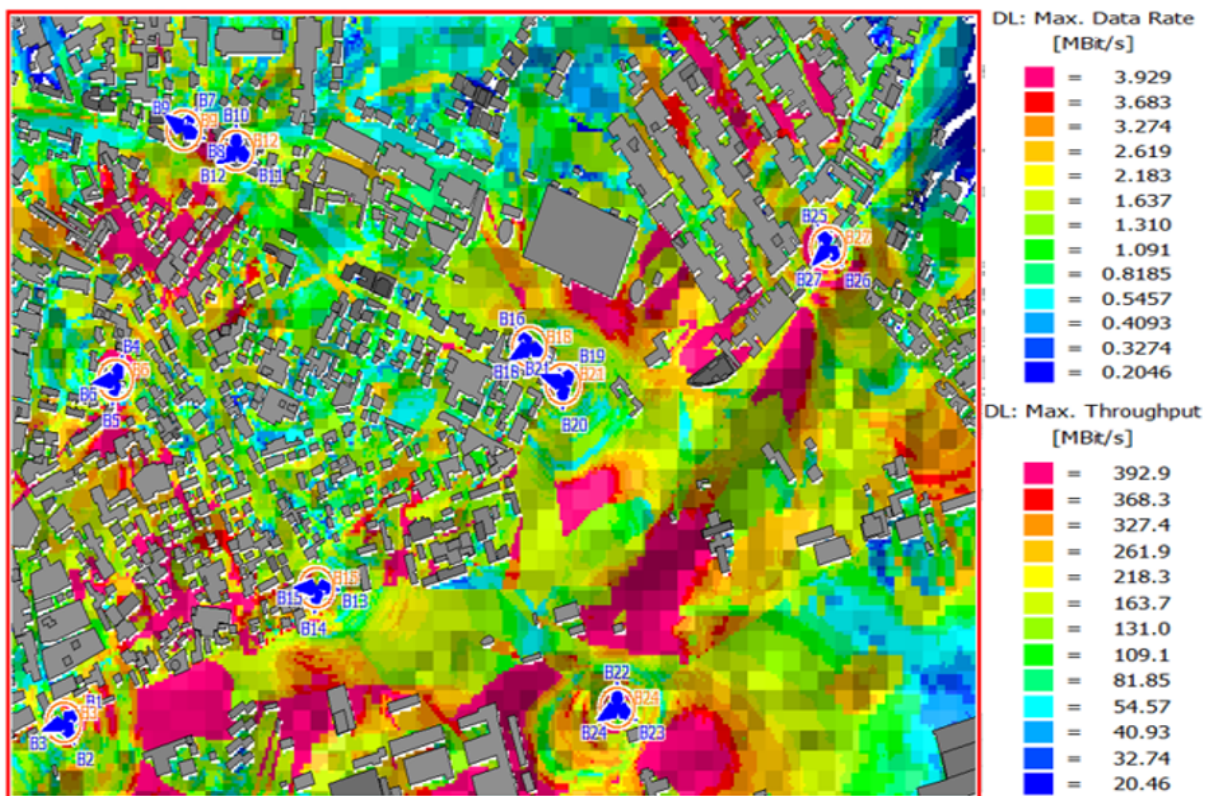

Figure 5.2: 4G-Advanced Simulation Result

5.1.3 Simulation of Sub-band (3.5GHz) on Existing 4G-Advanced Site

In this phase, a simulation is conducted to model the deployment of a 5G sub-band (3.5GHz) network on an existing 4G-Advanced site. Parameters are configured to reflect the sub-band's characteristics. The aim is to ascertain how the 5G sub-band performs in comparison to the benchmarked 4G network.

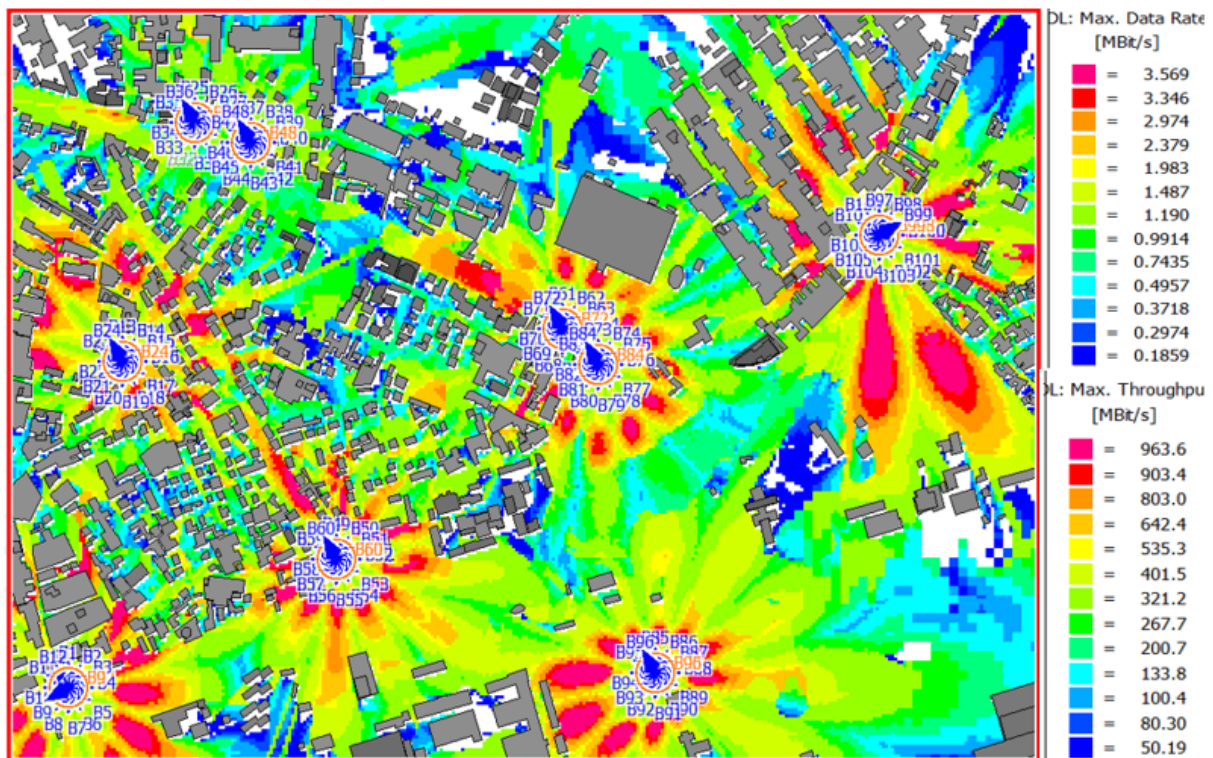

Figure 5.3: 5G sub-band(3.5GHz) on existing site Simulation Result

5.1.4 Simulation of Sub-band (3.5GHz) with Site Modification

This step involves augmenting the sub-band (3.5GHz) network's coverage and performance by strategically adding gNodeBs to areas with coverage gaps(holes) or weak signals. This modification optimizes network coverage and evaluates the effects of these additions on overall network performance with 9 existing sites and adds other 6 sites to cover gaps.

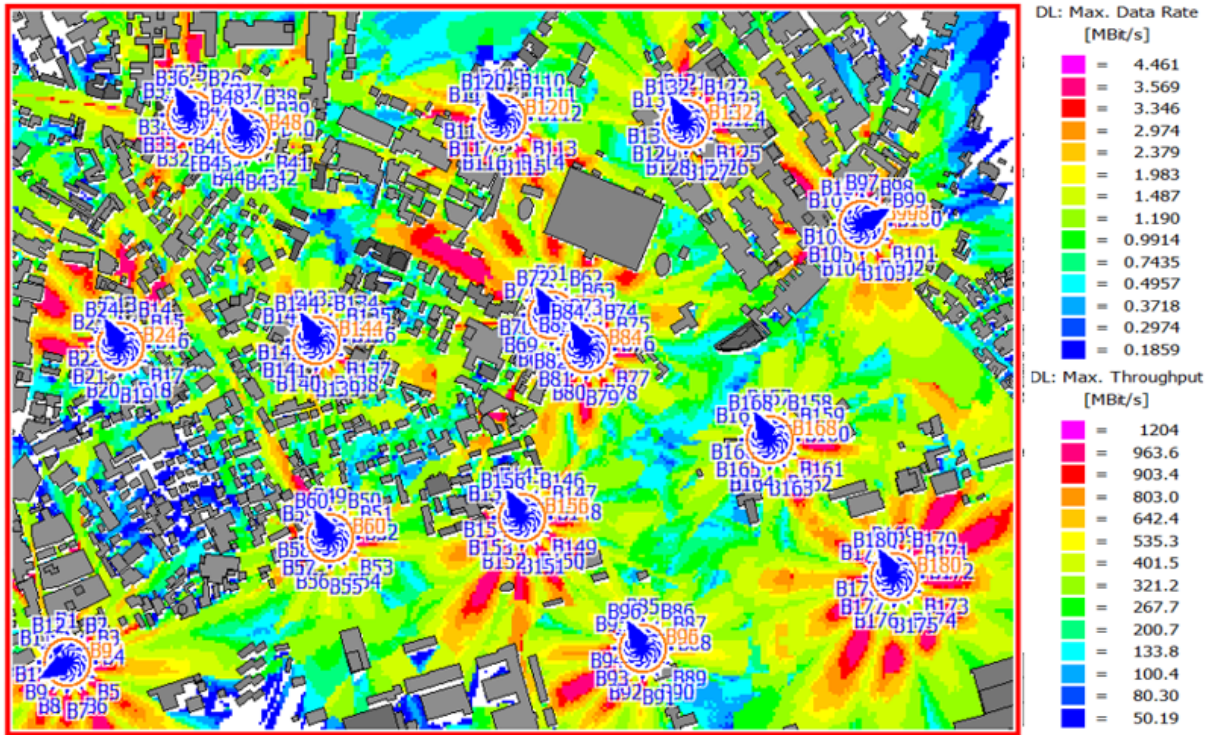

Figure 5.4: 5G Modified sub-band on existing site Simulation Result

5.1.5 Simulation of 5G mmwave (26GHz)

In the final step, the simulation focuses on deploying a 5G network operating in the mmwave (26GHz) frequency range, employing 30 gNodeBs. This simulation is tailored to account for the distinctive attributes of mmwave frequencies, characterized by their remarkable capacity potential and heightened susceptibility to signal obstruction by obstacles.

The primary objective is to comprehensively assess the 5G mmwave network’s ability to provide coverage, capacity, and performance, particularly in comparison to established benchmarks like the 5G sub-band and 4G-Advanced networks. This evaluation is vital, given that mmwave signals exhibit pronounced weakness in Figure 5.5 when it comes to penetrating physical obstructions, necessitating the consideration of advanced deployment strategies to maximize network efficiency and overcome coverage limitations.

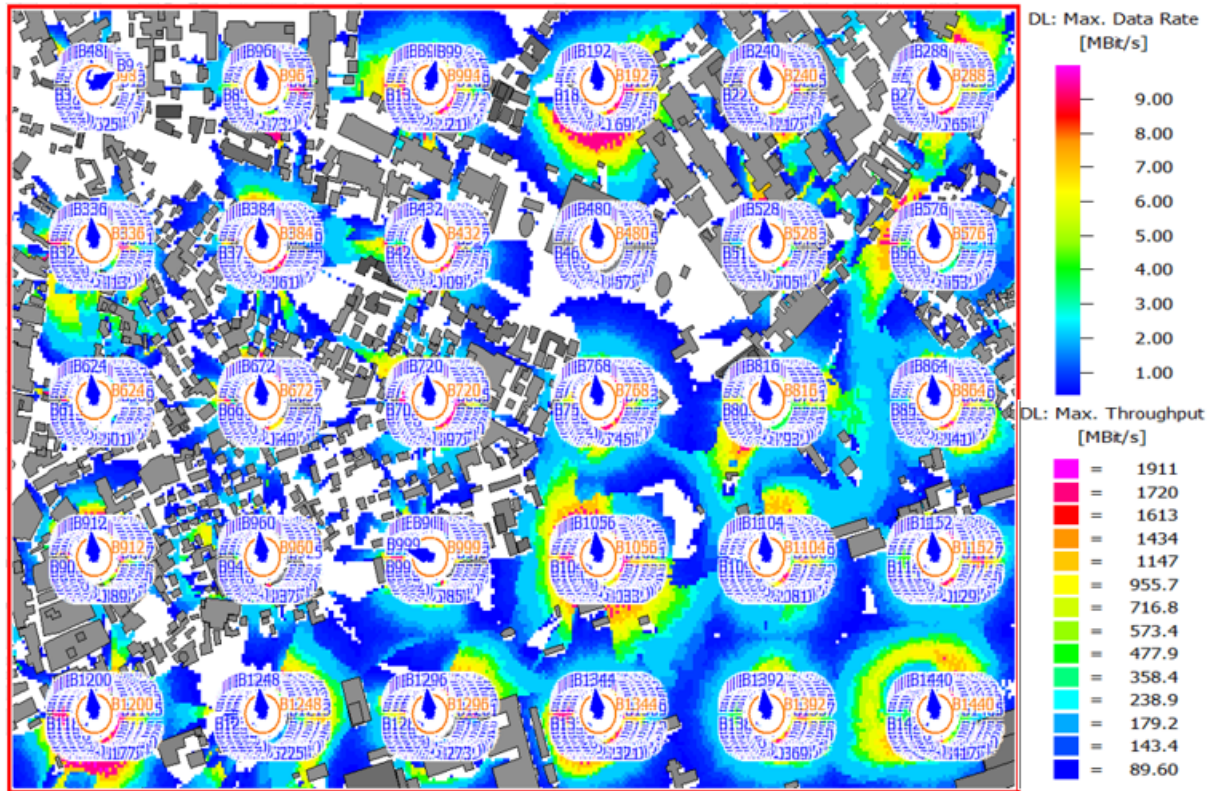

Figure 5.5: 5G mmwave(26GHz) Simulation Result

5.2 Network Coverage Performance Comparison

The coverage achieved by the sub-band (3.5GHz) and mmwave (26GHz) networks is compared to determine which frequency scenario offers broader coverage.

The network coverage performance evaluation involves a comprehensive examination of differences between the 5G sub-band (3.5GHz) and 5G mmwave (26GHz) frequency bands regarding network coverage. This detailed analysis integrates the signal quality indicators SS-RSRP (Serving Cell Reference Signal Received Power), SS-RSSI (Serving Cell Reference Signal Strength Indicator), and SS-RSRQ (Serving Cell Reference Signal Received Quality), along with coverage radius. These indicators collectively provide insights into the strength, quality, and extent of network coverage.

A comprehensive evaluation is conducted to compare the network coverage performance of three distinct frequency bands: 4G-Advance (2.6GHz), 5G sub-band (3.5GHz), and 5G mmwave (26GHz). This comparison is based on the SS-RSRP (Serving Cell Reference Signal Received Power) values of -120 dBm to -70 dBm, -113 dBm to -70 dBm, and -110

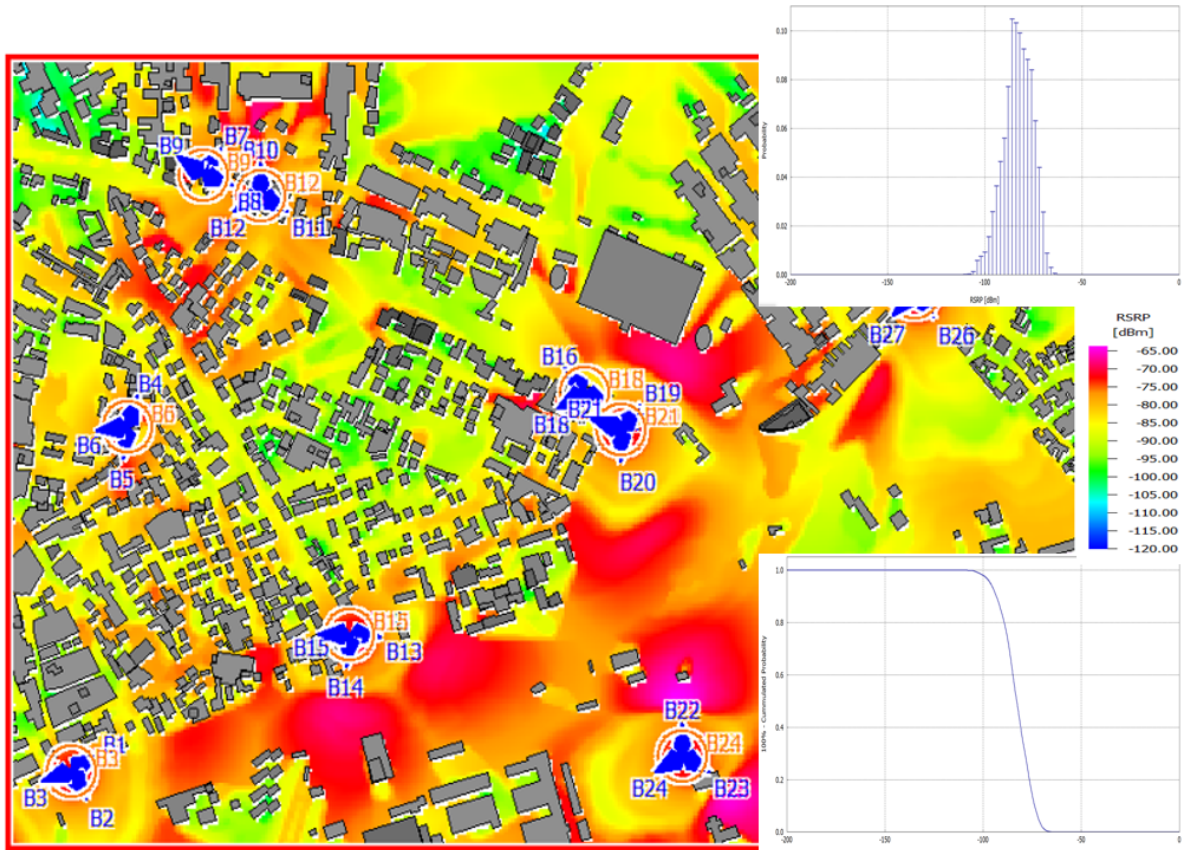

Figure 5.6: 4G-Advance SS-RSRP Simulation Result

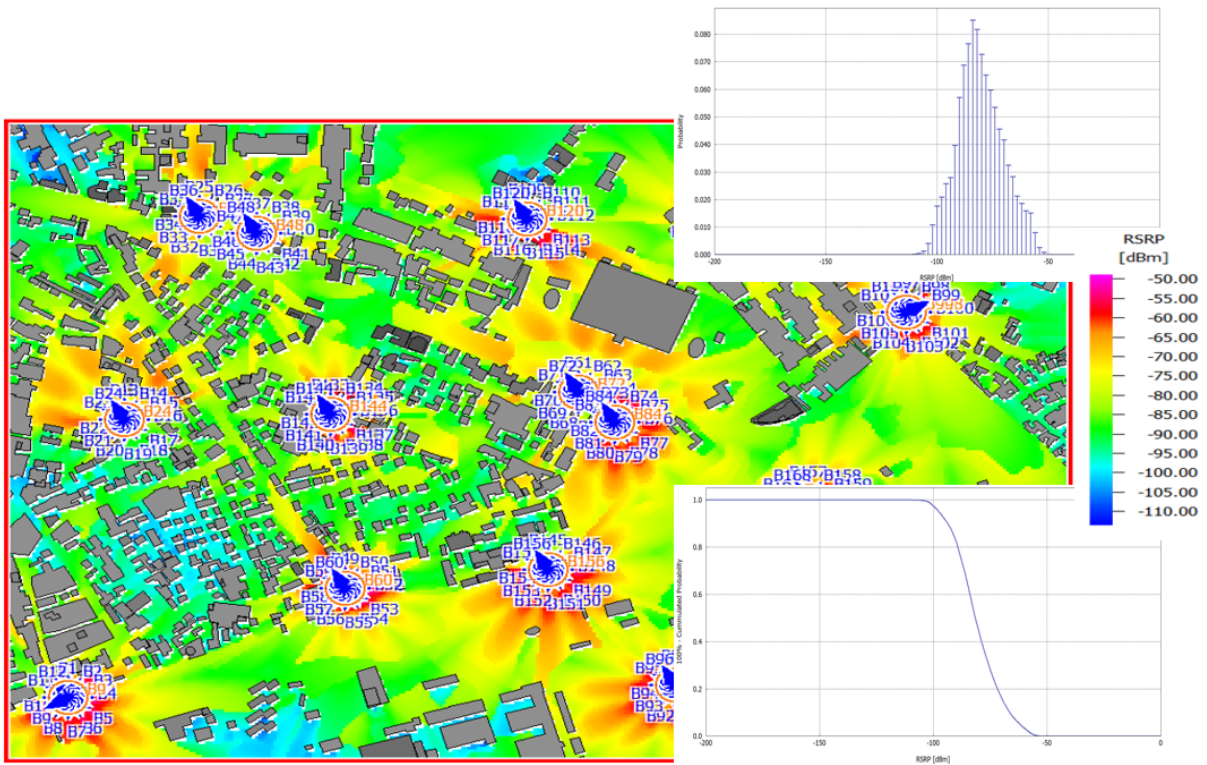

Figure 5.7: 5G Modified sub-band SS-RSRP Simulation Result

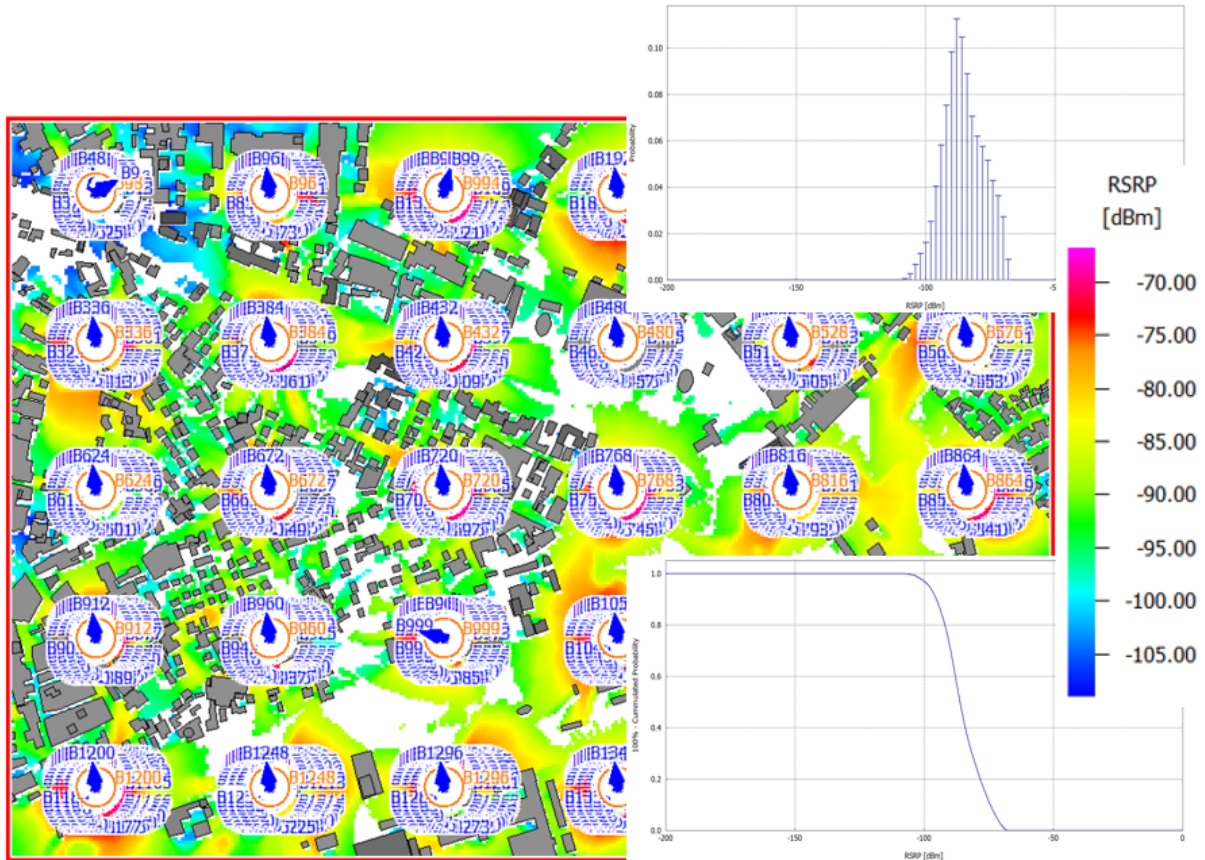

Figure 5.8: 5G mmwave SS-RSRP Simulation Result

dBm to -63dBm, respectively, for each frequency band. The primary goal of this network coverage performance comparison is to provide insights into the coverage capabilities of these frequency bands and to assess their suitability for different deployment scenarios see from Figure 5.9.

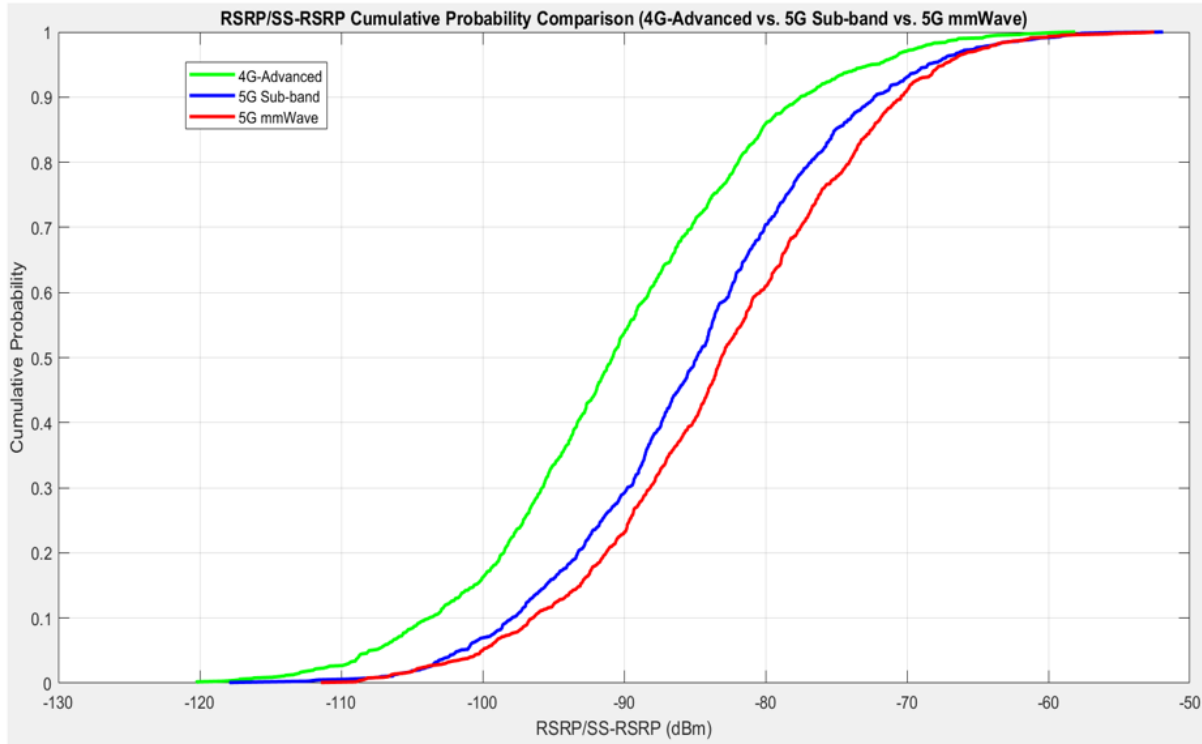

Figure 5.9: RSRP/SS-RSRP Analysis

5.2.1 Coverage Radius Analysis

The coverage radius represents the distance from a base station (gNodeB) where devices experience reliable signal reception. The analysis includes comparing the coverage radius between the 4G-advance, sub-band, and mmwave frequency bands. This comparison illustrates the reach of the network in both frequency ranges and the impact of propagation characteristics on coverage distance refer on Table 5.1 and on Figure 5.10.

Table 5.1: Different network technology of Coverage Radius

Network technology	Radius(Km)
4G-Advance	0.337
5G sub-band(3.5GHz)	0.262
5G mmwave(26GHz)	0.185

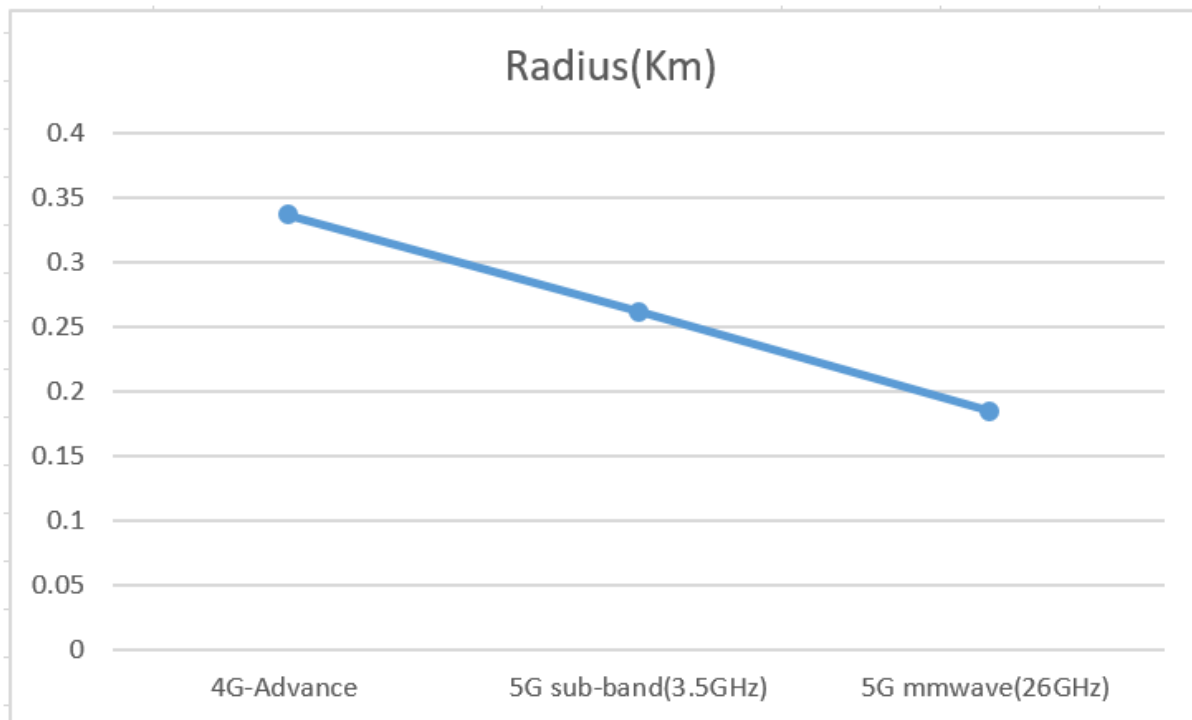

Figure 5.10: Coveragr Comparison by using Radius from Table 5.1

5.2.2 Coverage from capacity Perspective

5G Sub-band (3.5 GHz) with 40 Mbps Threshold: Covered 96.5% on figure 5.11

This means that with the designated coverage area of the 5G sub-band operating at 3.5 GHz, the network is designed to provide a minimum data rate of 40 Mbps to users. The coverage area has been carefully planned and engineered to encompass 96.5% of the targeted region. In other words, within this coverage area, users should expect to experience data rates of at least 40 Mbps. This is a high level of coverage, indicating that a vast majority of the specified region has access to the network's services.

The fact that 96.5% of the area is covered suggests that the network's signal should be available and usable across most urban and suburban settings, and potentially even some rural areas. This type of coverage is particularly important for ensuring a consistent and reliable experience for users across a wide range of scenarios.

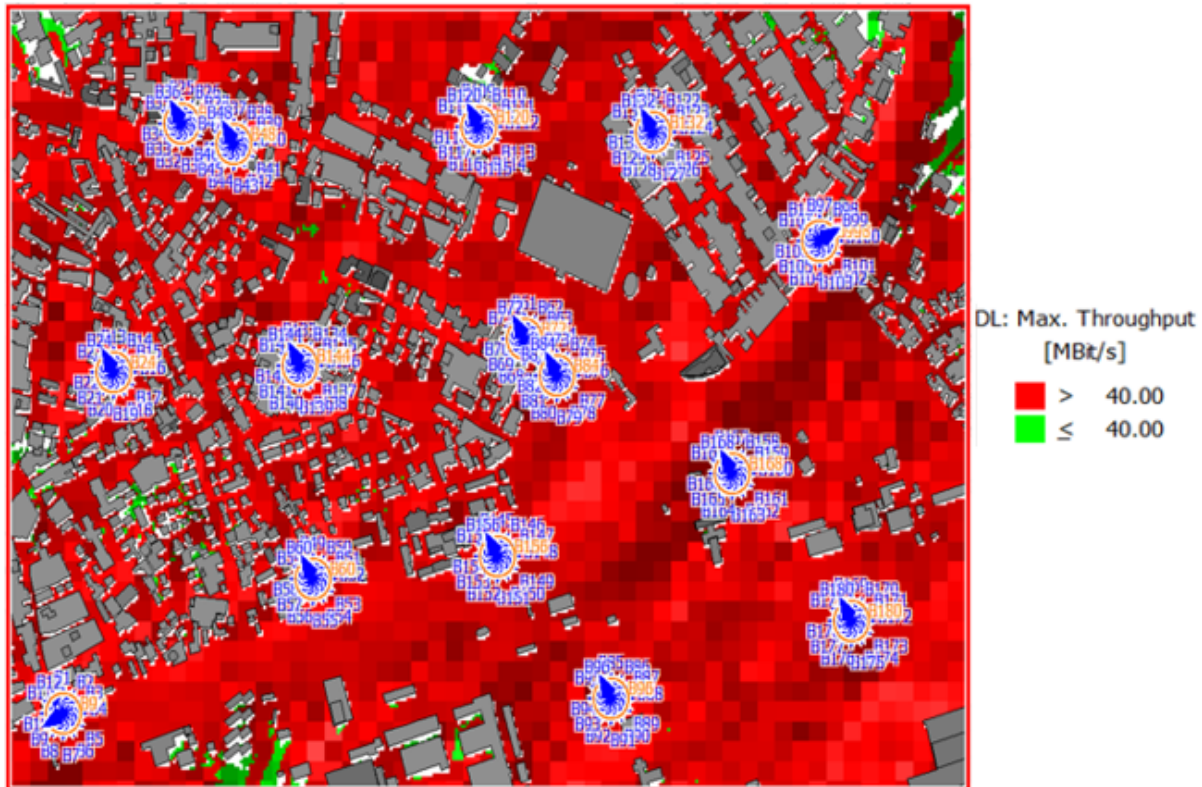

Figure 5.11: 5G sub-band(3.5GHz) coverage with 40 Mbps threshold Simulation Result

5G mmwave (26 GHz) with 100 Mbps Threshold: Covered Near to 68% figure 5.12

The 5G mmwave operating at 26 GHz is known for its high data rates but also for its limited coverage area due to its higher frequency characteristics. In this case, the network is designed to deliver a minimum data rate of 100 Mbps within the coverage area. However, the coverage area for mmwave is more constrained compared to lower frequency bands due to the challenges of signal propagation at higher frequencies.

When it's mentioned that the coverage is "near to 68%," it means that approximately 68% of the specified area is within the coverage zone for this mmwave network. This suggests that the network's services are available in more limited geographic regions compared to the sub-6 GHz bands. The coverage area might encompass dense urban areas, stadiums, high-traffic locations, and other specific zones where the higher capacity of mmwave can be effectively utilized.

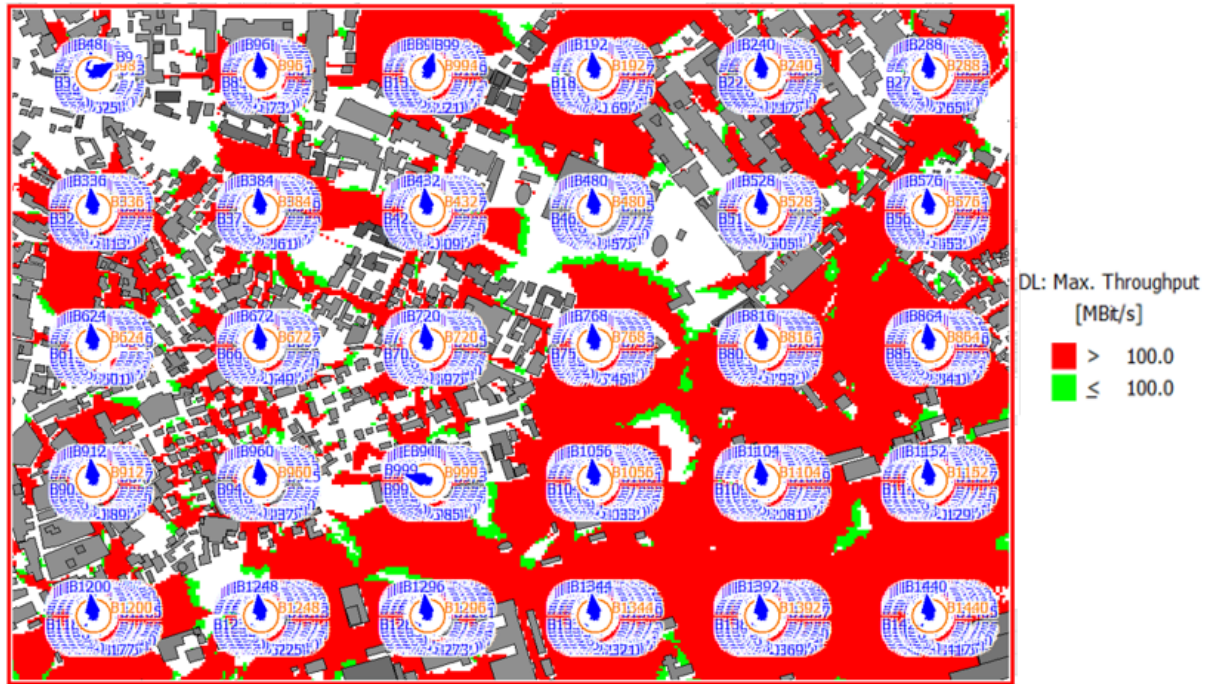

Figure 5.12: 5G mmwave(26GHz) coverage with 100 Mbps threshold Simulation Result

5.3 Network Capacity Performance Comparison

An extensive network capacity performance comparison is conducted using data rate and throughput metrics. This comparison assesses the data transmission capabilities of three distinct frequency bands: 4G-Advance (2.6GHz), 5G sub-band (3.5GHz), and 5G mmwave (26GHz). The objective is to gain insights into the capacity of these frequency bands to handle data traffic efficiently and provide higher data rates and throughput.

Data Rate and Throughput Calculation: Data rate refers to the rate at which data can be transmitted over the network, while throughput represents the amount of data that can be successfully transmitted within a given timeframe. For each frequency band, the data rates and throughput are calculated based on simulations that replicate real-world usage scenarios.

5.3.1 Data Rate and Throughput Simulation Calculation

Data rate refers to the rate at which data can be transmitted over the network, while throughput represents the amount of data that can be successfully transmitted within a

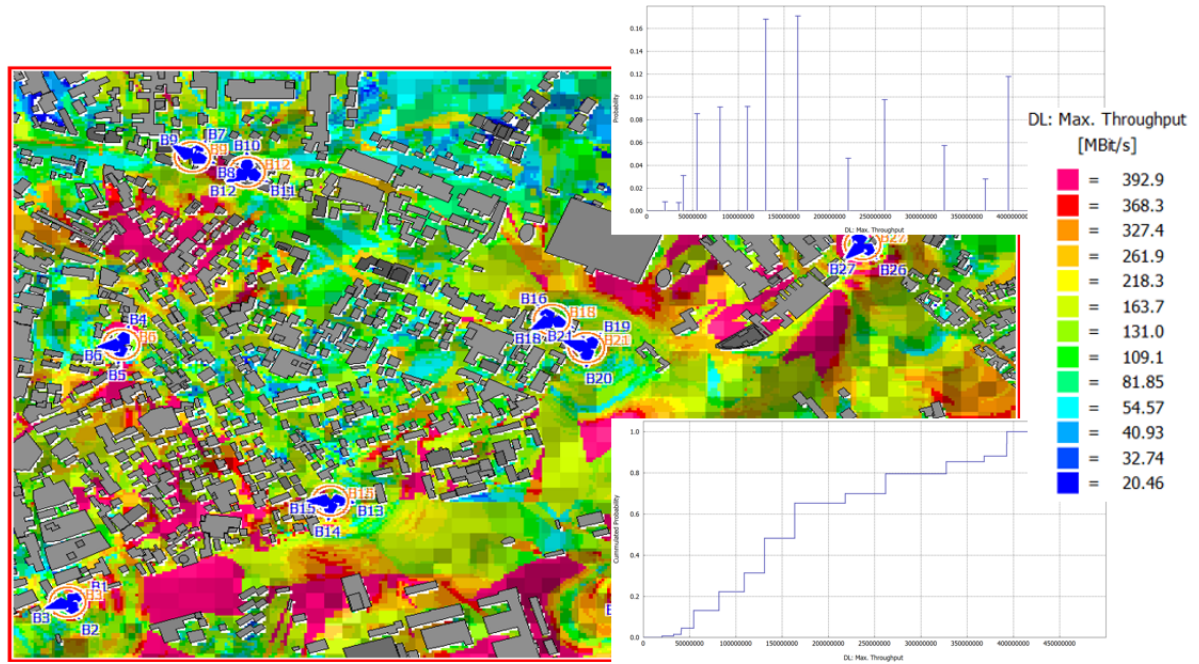

Figure 5.13: 4G-Advance capacity Simulation Result

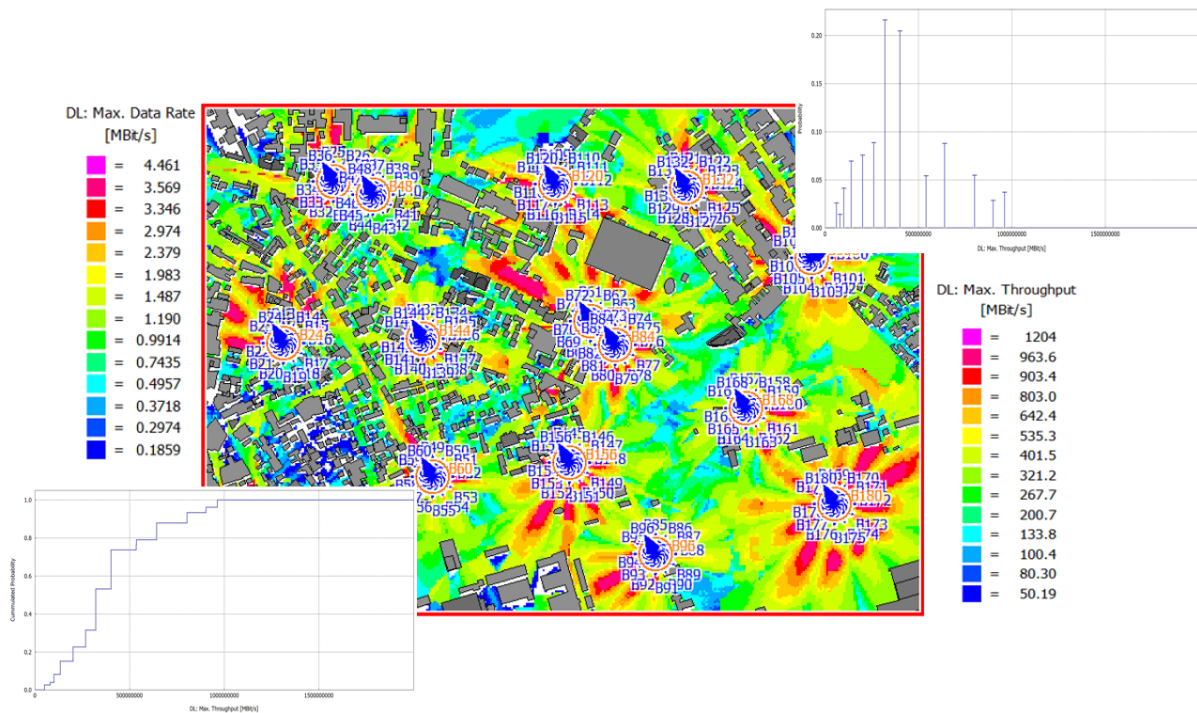

Figure 5.14: 5G modified sub-band capacity Simulation Result

given timeframe. The data rates and throughputs are calculated for each frequency band based on simulations replicating real-world usage scenarios.

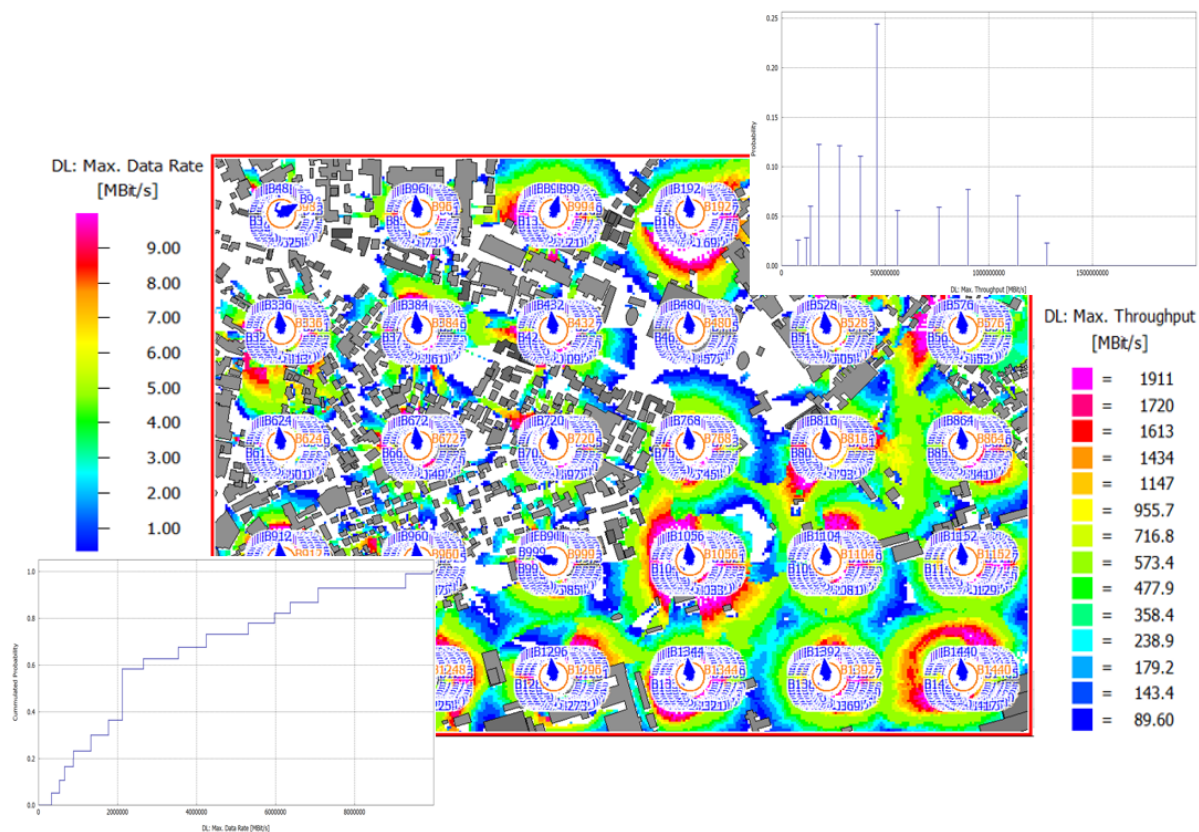

Figure 5.15: 5G mmwave(26GHz) capacity Simulation Result

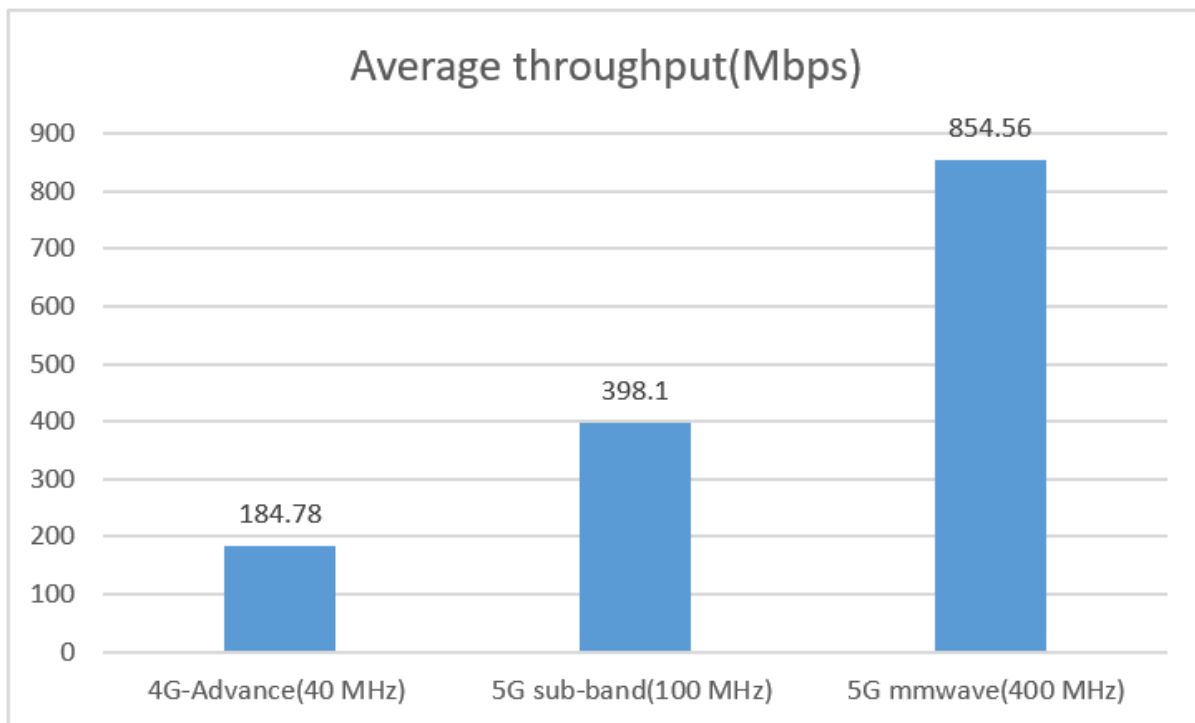

Figure 5.16: Average throughput analysis

5.4 Network Quality Performance Comparison

In the context of 5G networks, SS-RSRQ is a critical metric that reflects the quality of synchronization and reference signals received by user equipment (UE) from base stations (BS). It takes into account both the signal strength and the level of interference or noise present in the received signals. By using simulation results, we can draw insights into how these two different frequency bands perform in terms of signal quality and interference levels.

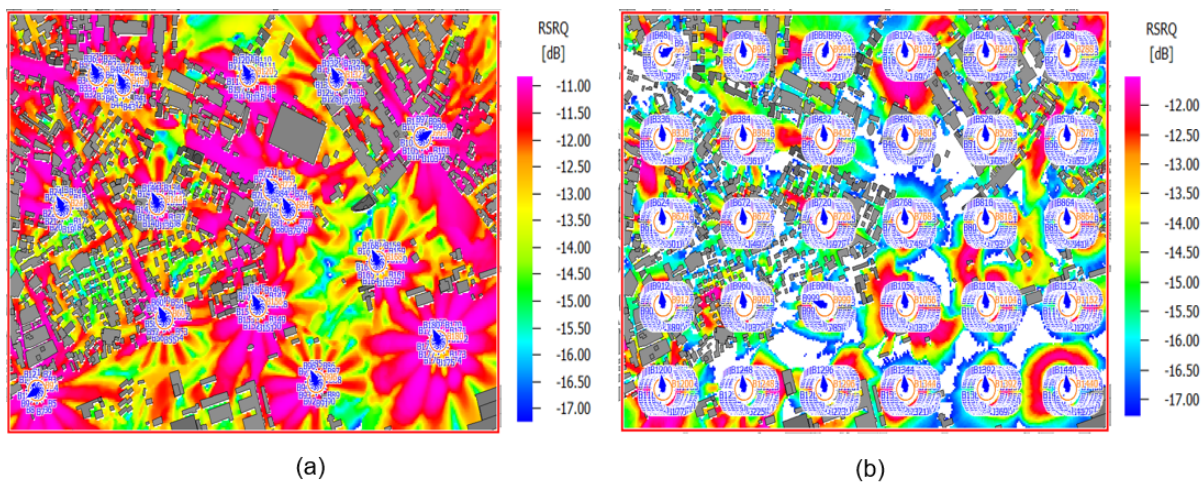

Figure 5.17: 5G Network SS-RSRQ Simulation Result (a) 5G sub-band (b) 5G mmwave

5.4.1 SINR Comparison

The SS-SINR (Secondary Synchronization Signal-to-Interference and Noise Ratio) comparative performance analysis between 5G sub-band (3.5GHz) and 5G mmwave (26GHz) is a critical aspect of network planning and optimization. Sub-band frequencies, operating in the lower spectrum range, tend to provide more robust coverage and better signal propagation through obstacles, making them well-suited for wider area deployments and indoor scenarios.

Conversely, mmwave frequencies, despite their potential for extremely high data rates, have limited propagation range and are prone to signal blockage by obstacles, especially in dense urban environments. The SS-SINR analysis evaluates how these frequency bands

perform in terms of signal quality, interference, and noise, directly impacting network capacity, data rates, and overall user experience. This analysis guides network engineers and operators in making informed decisions about frequency band selection based on specific deployment requirements and trade-offs between coverage and capacity.

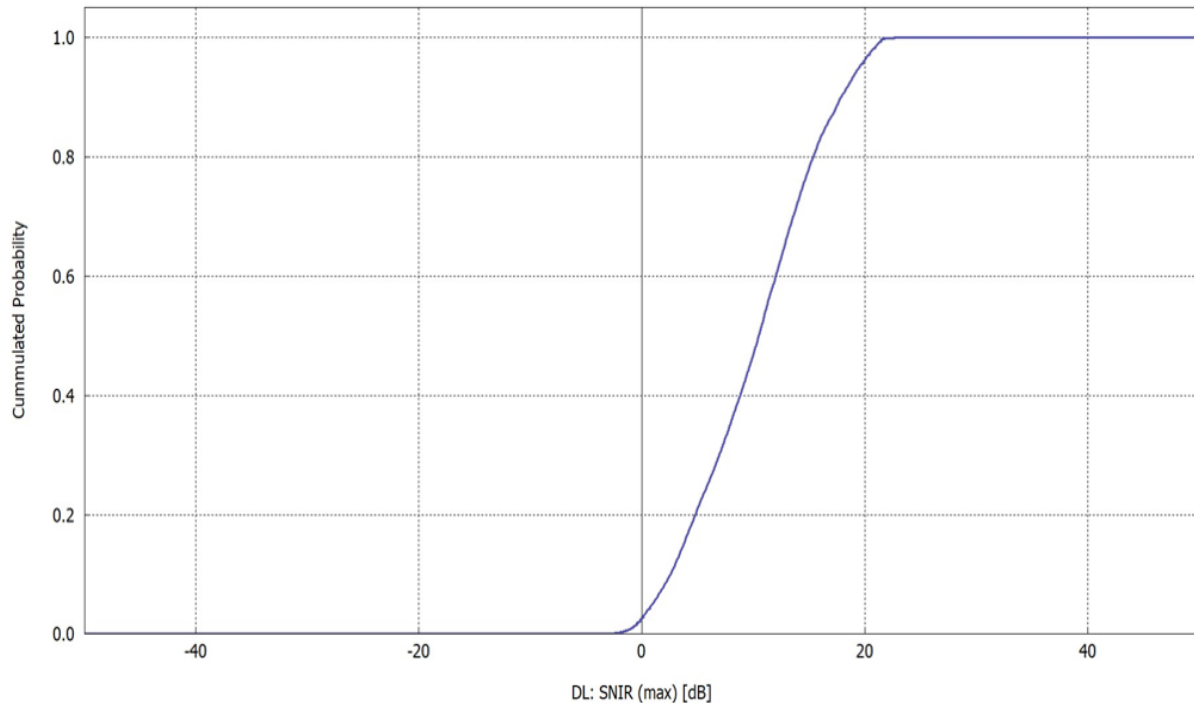

Figure 5.18: 4G Advanced SINR

4G-Advanced (LTE-A): In the comparison, 4G-Advanced shows the lowest SINR values among the three technologies. This is expected as 4G networks operate at lower frequencies, often below 2 GHz. Lower frequency bands have less capacity for higher data rates and may experience more interference, resulting in lower SINR. However, 4G-Advanced is still capable of providing relatively stable and efficient communication.

5G Sub-band (3.5 GHz): The SINR values for 5G sub-band, which operates in the mid-band spectrum around 3.5 GHz, show a moderate improvement compared to 4G-Advanced. This improvement is due to the higher frequency, which allows for increased data capacity and potentially reduced interference compared to lower frequency bands. Users in this band can experience better data rates and overall network performance compared to 4G.

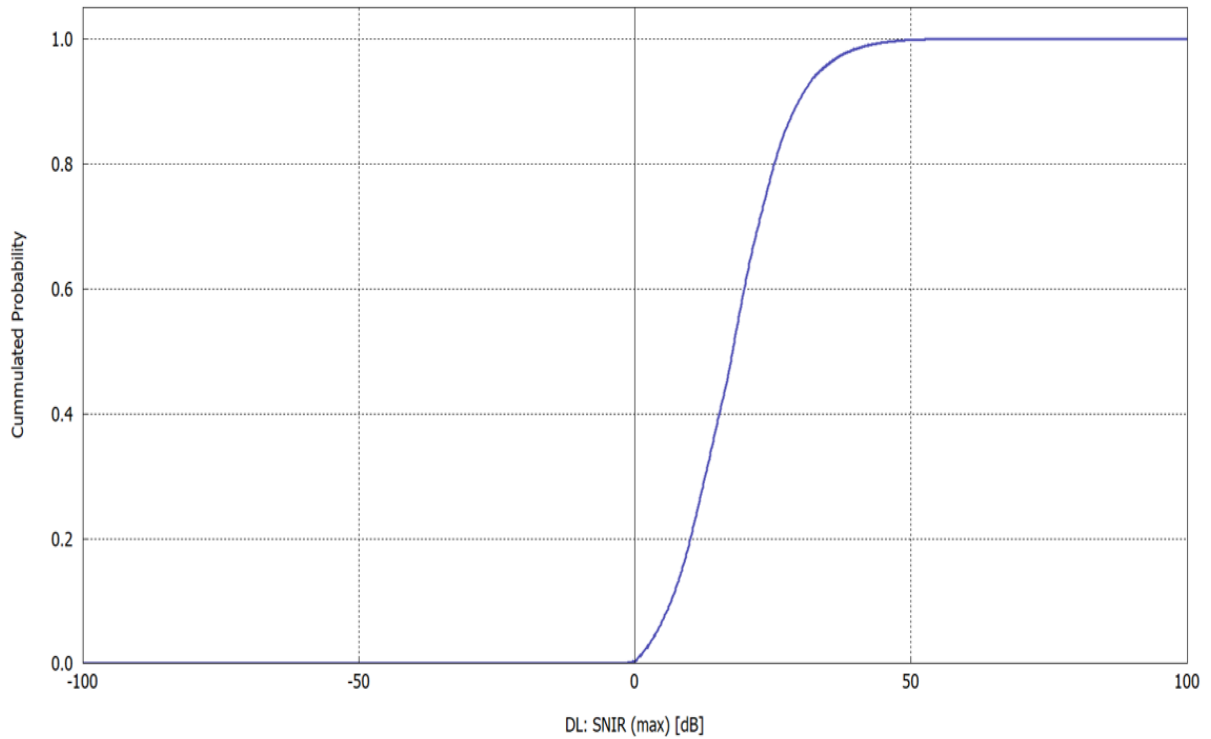

Figure 5.19: 5G mmwave(26GHz) SINR

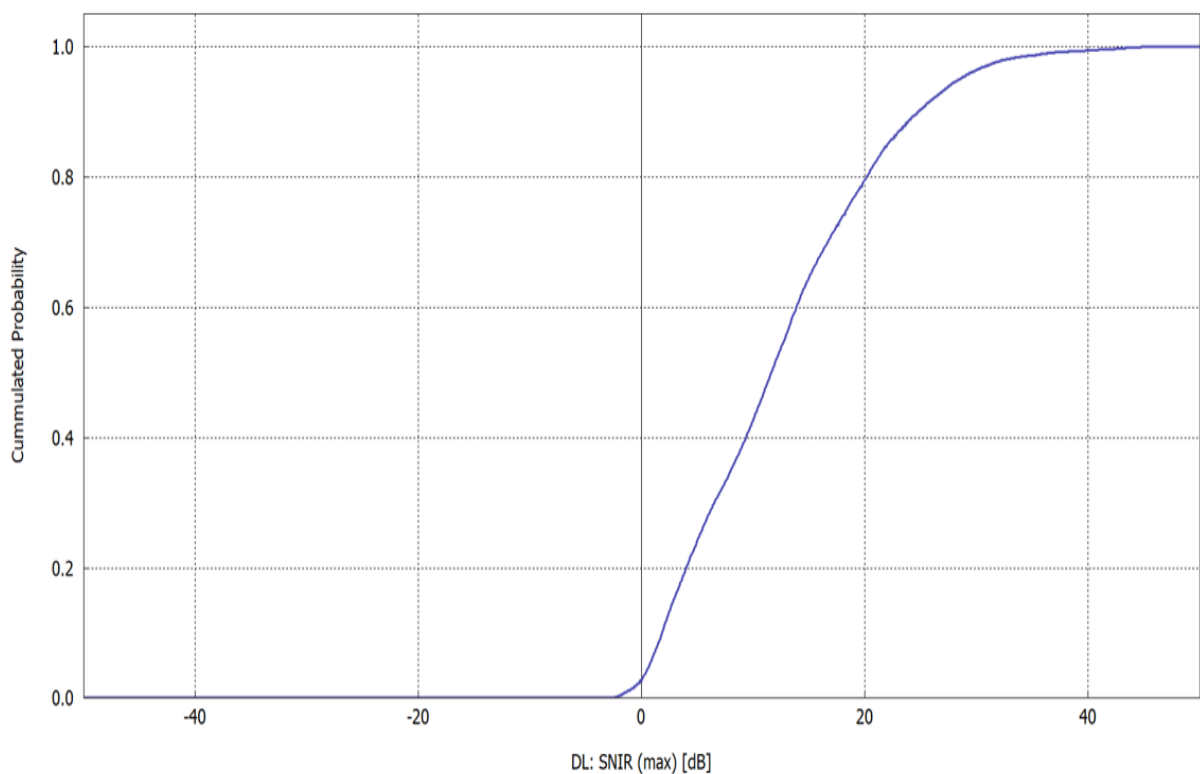

Figure 5.20: 5G sub-band(3.5GHz) SINR

5G mmwave (26 GHz): 5G mmwave demonstrates the highest SINR values among

the three technologies. Operating in the mmwave spectrum offers a significant advantage in terms of capacity and reduced interference. However, it's important to note that mmwave signals are highly directional and have limited coverage range, making network deployment and coverage planning critical. The higher SINR in mmwave indicates the potential for extremely high data rates and low latency, which are key features of 5G for applications like ultra-fast downloads and low-latency communication.

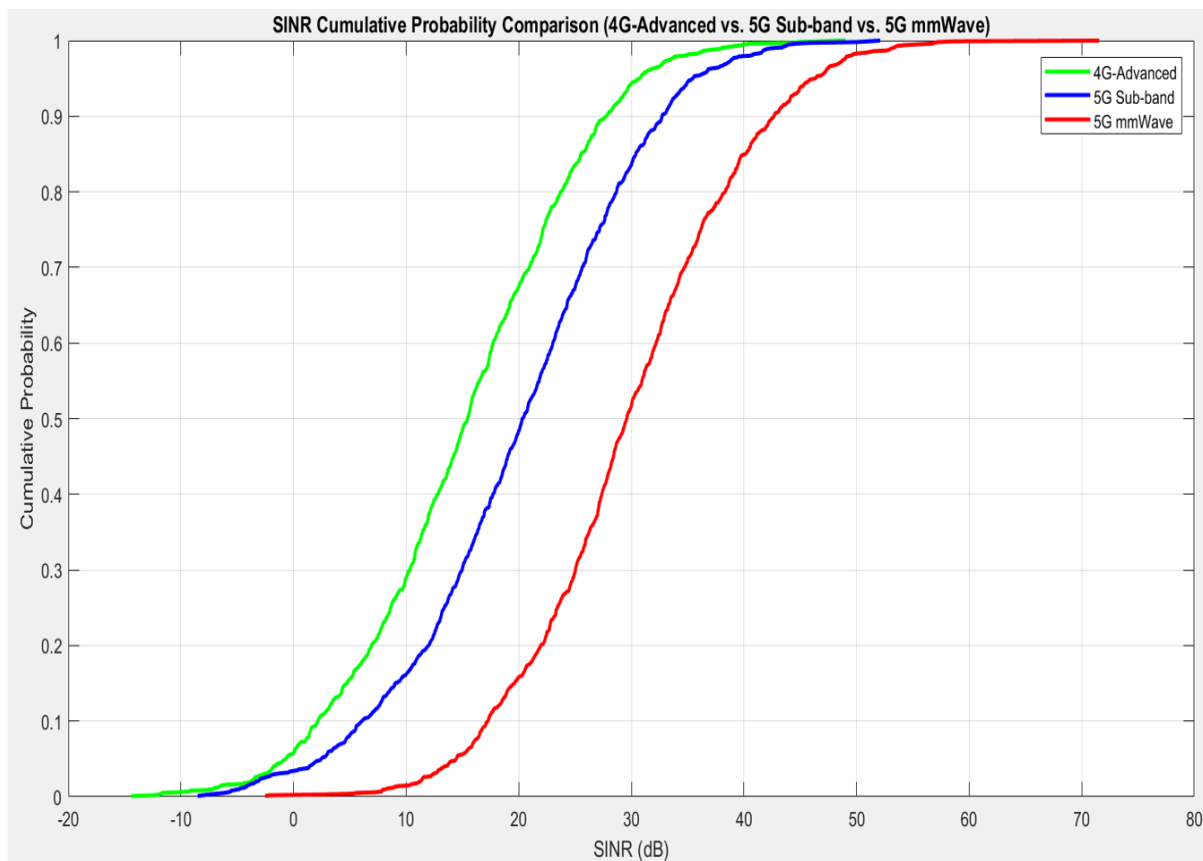

Figure 5.21: SINR Comparative Analysis

5G Network Comparison Simulation Results Qualitatively

5.4.2 Coverage and Capacity Discussion and Findings

The coverage performance findings are explored based on radio planning, coverage analysis, and capacity simulations. The aim is to provide a comprehensive understanding of the coverage capabilities of each frequency band in relation to one another.

4G-Advance (2.6GHz) Coverage Analysis

The simulation results for the 4G-Advance frequency band at 2.6GHz indicate its established outdoor coverage area and signal propagation characteristics. It serves as a benchmark for comparison. The discussion can highlight its relatively wider outdoor coverage, making it suitable for urban and suburban environments. However, limitations in dense urban areas and signal penetration through obstacles should be considered.

5G Sub-band (3.5GHz) Coverage Potential

The qualitative analysis of the 5G sub-band at 3.5GHz reveals its potential for enhanced coverage compared to 5G mmwave. This higher frequency range enables better signal penetration through buildings and obstacles, resulting in improved outdoor coverage in urban scenarios. The discussion can emphasize how this band can address coverage gaps and enhance connectivity, particularly in densely populated areas.

5G Millimeter Wave (26GHz) Urban Coverage analysis

The discussion on the 5G millimeter wave frequency band at 26GHz highlights its unique characteristics. While its outdoor coverage area is shorter, it excels in delivering high-capacity connections in urban areas. The discussion can compare its coverage potential with the other bands, showcasing its suitability for high-demand scenarios and urban hotspots, such as shopping centers or event venues.

The comparative analysis of coverage performance findings considers outdoor coverage reach, signal propagation capabilities, and potential coverage gaps in various scenarios. It highlights the trade-offs between coverage and capacity for each frequency band, offering insights into their specific applications and strengths in different deployment scenarios.

Capacity Discussion and Findings The capacity performance findings are explored based on radio planning, coverage analysis, and capacity simulations. The objective is to offer a comprehensive understanding of the capacity capabilities of each frequency band and their relative strengths.

4G-Advance (2.6GHz) Capacity Analysis

The simulation results for the 4G-Advance frequency band at 2.6GHz provide insights into its capacity capabilities. While it offers stable and reliable connections with a reasonable data rate, the discussion can highlight potential challenges in densely populated areas. Due to its lower frequency, it might face limitations in delivering ultra-high data rates required for modern applications such as high-definition video streaming or virtual reality.

5G Sub-band (3.5GHz) Enhanced Capacity Potential

The qualitative analysis of the 5G sub-band at 3.5GHz demonstrates its capacity potential compared to 4G-Advance. The higher frequency range allows for greater data rates and throughput, making it suitable for addressing the growing demands of data-intensive applications. The discussion can emphasize its capability to support higher user densities and offer enhanced user experiences with faster data speeds.

5G Millimeter Wave (26GHz) High-Capacity Characteristics

The discussion on the 5G millimeter wave frequency band at 26GHz highlights its high-capacity characteristics. While its coverage area is relatively localized, it excels in providing ultra-high data rates and throughput. The discussion can qualitatively compare its capacity potential with the other bands, showcasing its ability to cater to scenarios requiring massive data transfer, such as crowded event venues or urban centers.

The comparative analysis of capacity performance findings considers data rates, throughput, and the ability to support high user densities. It underscores the trade-offs between coverage and capacity for each frequency band, offering insights into their specific applications and strengths in different usage scenarios.

Chapter 6

Conclusion and Future work

6.1 Conclusion

In conclusion, our comprehensive analysis of 5G mobile radio network coverage, capacity, and cost performance between the 5G sub-band (3.5GHz) and 5G mmwave (26GHz) has shed light on crucial aspects of these two frequency bands. Through the application of radio network planning coverage, capacity simulation, and cost assessment, we've gained valuable insights into their respective strengths and limitations.

Starting with coverage, the SS-RSRP results indicated that 5G mmwave (26GHz) is a higher value of -110 dBm compared to 5G sub-band's (3.5GHz) -113 dBm. This suggests that the sub-band has advantage in terms of coverage reachability, likely due to its better propagation characteristics and ability to penetrate obstacles.

Moving on to capacity, our capacity simulation revealed a significant performance gap between the two frequency bands. Specifically, the 5G mmwave (26GHz) capacity exceeding twice that of 5G sub-band (3.5GHz). This remarkable difference underscores the mmwave's ability to offer substantially higher data rates and accommodate a larger number of connected devices. However, this advantage is balanced by its inherent limitations, such as shorter range and susceptibility to signal blockage by obstacles.

Finally, our cost comparison analysis has illuminated an interesting dynamic between the two frequency bands. In the short run, 5G sub-band (3.5GHz) demonstrates a better cost performance. Its deployment is associated with lower initial expenses, making it a favorable choice for rapid implementation. On the other hand, 5G mmwave (26GHz) exhibits a stronger cost advantage in the long run. Despite its higher initial costs, the mmwave's significantly enhanced capacity and data rates position it as a more cost-efficient option over time due to its ability to cater to growing data demands and evolving network needs.

6.2 Future Work

The study "Coverage, Capacity and Cost Performance Analysis of 5G Sub-band(3.5GHz) and 5G Millimeter-wave(26GHz)" highlights the need for further research on optimizing hybrid networks combining both sub-bands(3.5 GHz)and mmwave(26 GHz). This is because hybrid networks have the potential to offer the best of both worlds: the wide coverage and good penetration of sub-bands, and the ultra-high capacity and low latency of mmwave.

However, there are a number of challenges that need to be addressed in order to optimize hybrid networks. One challenge is how to seamlessly hand over users between sub-bands and mmwave as they move around. Another challenge is how to allocate resources between the two bands in a way that maximizes overall performance.

Furthermore, there is a compelling opportunity to investigate the reliability and performance of a network mix, simulating the simultaneous operation of both sub-band and mmwave frequencies. Such an investigation could provide a nuanced understanding of the dynamics between the two frequency ranges, offering insights into achieving a synergistic network configuration that optimizes coverage, capacity, and cost efficiency. This multi-faceted exploration promises to reshape the landscape of 5G deployment, unlocking new potentials for robust and high-capacity connectivity solutions.

Bibliography

- [1] Ericsson, "Ericsson Mobility Report" Q2 Update, August 2022.
- [2] E. Monitor, "Ethiopian Monitor," 28 July 2022. [Online]. Available: <https://ethiopianmonitor.com/2022/07/28/Ethio-telecom-reports-61-3bln-birr-annual-revenue/>.
- [3] Beneyam B., "On the relevance of capacity enhancing 5G technologies for Ethiopia," in 10th Ethiopian ICT Annual Conference (EICTC-2017) 3, Addis Ababa, 2017.
- [4] <https://www.statista.com/statistics/749569/ethiopia-ethio-telecom-data-and-internet-subscribers/>
- [5] <https://www.howtogeek.com/428337/not-all-5g-is-equal-millimeter-wave-low-band-and-mid-band-explained/>
- [6] <https://www.macrumors.com/guide/mmwave-vs-sub-6ghz-5g/>
- [7] Ahamed, M.M.; Faruque, S. 5G Network Coverage Planning and Analysis of the Deployment Challenges. *Sensors* 2021, 21, 6608. <https://doi.org/10.3390/s21196608>
- [8] Tristan Curry; Robert Abbas "5G Coverage, Prediction, and Trial Measurements" arXiv:2003.09574v1 [eess.SP] 21 Mar 2020. <https://arxiv.org/pdf/2003.09574.pdf>
- [9] S. B. Barutu, A. Hikmaturokhman and M. P. K. Praja, "Planning of 5G New Radio (NR) mmwave 26 GHz in Karawang Industrial Area," 2020 IEEE International Conference on Communication, Networks and Satellite (Comnetsat), Batam, Indonesia, 2020, pp. 42-49, doi: 10.1109/Comnetsat50391.2020.9329010.
- [10] A. Sukarno, A. Hikmaturokhman and D. Rachmawaty, "Comparison of 5G NR Planning in Mid-Band and High-Band in Jababeka Industrial Estate," 2020 IEEE International Conference on Communication, Networks and Satellite (Comnetsat), Batam, Indonesia, 2020, pp. 12-17, doi: 10.1109/Comnetsat50391.2020.9329000.
- [11] Efrem, Teshome "5G New Radio Network Dimensioning and Optimization: A Case Study in Arada Sub-City Addis Ababa Arada Sub-City Addis Ababa" <http://ir.bdu.edu.et/handle/123456789/14522>

-
- [12] M. Sousa, A. Alves, P. Vieira, M. P. Queluz and A. Rodrigues, "Analysis and Optimization of 5G Coverage Predictions Using a Beamforming Antenna Model and Real Drive Test Measurements," in *IEEE Access*, vol. 9, pp. 101787-101808, 2021, doi: 10.1109/ACCESS.2021.3097633.
- [13] Eshetu Tessema W., "5G Radio Network Dimensioning and Millimetric Wave Propagation Modeling: The Case of Kirkos Sub-city, Addis Ababa" September, 2020
- [14] Sheikh, Tasher; Babul, Rahman "Evolution of Mobile Communication Networks" National Conference on Recent Trends in Electronics and Communication Engineering (NCRT-ECE- 2020) August 2020
- [15] Salih, Azar "Evolution of Mobile Wireless Communication to 5G Revolution" Article in Technology Reports of Kansai University · June 2020 <https://www.researchgate.net/publication/342549960>
- [16] A. Minokuchi, et.al, "5G standardization Trends at 3GPP", *NTT DOCOMO Technical Journal* Vol.19, No.3PP.5-12, Jan.2018.
- [17] Gus Vos "What is 5G NR (New Radio)?" January 2022 <https://www.sierrawireless.com/iot-blog/what-is-5g-nr/>
- [18] 5G System; Technical Realization of Service Based Architecture; Stage 3 (3GPP TS 29.500 version 16.4.0 Release 16)
- [19] 5G; NR; NR and NG-RAN Overall description; Stage-2 (3GPP TS 38.300 version 16.2.0 Release 16)
- [20] 3GPP TS 38.401: "NG-RAN; Architecture description", version 15.3.0 Release 15
- [21] 5G; NR; Physical channels and modulation (3GPP TS 38.211 version 16.7.0 Release 16)
- [22] <https://www.sharetechnote.com/html/5G/5G Waveform.html>
- [23] Concepts of Orthogonal Frequency Division Multiplexing (OFDM) and 802.11 WLAN", Keysight Technologies web page,

-
- [24] A. F. Demir, M. Elkourdi, M. Ibrahim, and H. Arslan, “Waveform design for 5G and beyond,” in *5G Networks: Fundamental Requirements, Enabling Technologies, and Operations Management*. John Wiley and Sons, Ltd, 2018, ch. 2, pp. 51–76., which has been published in final form at [<https://onlinelibrary.wiley.com/doi/abs/10.1002/9781119333142.ch2>]
- [25] 5G; NR; Physical channels and modulation (3GPP TS 38.211 version 15.2.0 Release 15)
- [26] ITU-R, “Minimum requirements related to technical performance for radio interface(s),” IMT-2020 2017.
- [27] R. Dilli, ”Analysis of 5G Wireless Systems in FR1 and FR2 Frequency Bands,” 2020 2nd International Conference on Innovative Mechanisms for Industry Applications (ICIMIA), Bangalore, India, 2020, pp. 767-772, doi: 10.1109/ICIMIA48430.2020.9074973.
- [28] 5G; NR; User Equipment (UE) radio transmission and reception; Part 1: Range 1 Standalone (3GPP TS 38.101-1 version 15.2.0 Release 15)
- [29] 5G; NR; User Equipment (UE) radio transmission and reception; Part 2: Range 2 Standalone
- [30] IPLOOK 5GC Product description
- [31] Chataut, R., and Akl, R. (2020). Massive MIMO Systems for 5G and Beyond Networks—Overview, Recent Trends, Challenges, and Future Research Direction. *Sensors* (Basel, Switzerland), 20(10). <https://doi.org/10.3390/s20102753>
- [32] Carl Lutnaes ”Beamforming in 5G mm-wave radio” March 2020
- [33] 3GPP TR 38.802 (V14.2.0)-6.1.6.1
- [34] S.E.Elayoubi, ”5G service requirements and operational use cases: Analysis and METIS II vision,” in *Proc. IEEE Eur. Conf. Netw. Commun. (EuCNC)*, 2016.
- [35] Alcobia, B. LTE radio network deployment design in urban environments under different traffic scenarios. Diss. M. Sc. Thesis, Instituto Superior Técnico, Lisbon, Portugal, 2017.

-
- [36] Kumar, Suman; Kalyani, S.”Optimal Thresholds for Coverage and Rate in FFR Schemes for Planned Cellular Networks” January 2014
- [37] 5G; NR; Medium Access Control (MAC) protocol specification(3GPP TS 38.321 version 15.3.0 Release 15)
- [38] 5G; Study on channel model for frequencies from 0.5 to 100 GHz (3GPP TR 38.901 version 16.1.0 Release 16)
- [39] <https://www.rfwireless-world.com/Terminology/Okumura-Hata-Model-basics.html>
- [40] Chhaya, D., Prasad, M.V.S.N. and Dalela, P.K. (2012) TUNING OF COST-231 HATA MODEL FOR RADIO. Computer Science and Information Technology, 5, 255-267.
- [41] ITU Workshop: Overview of activities of ITU-R Study Group 3 on radio wave propagation, 10 April 2014
- [42] JOUR, Kyösti, Pekka”WINNER II channel models” February 2008
- [43] L. Liu et al., ”The COST 2100 MIMO channel model,” in IEEE Wireless Communications, vol. 19, no. 6, pp. 92-99, December 2012, doi: 10.1109/MWC.2012.6393523.
- [44] Leszek Raschkowski”METIS Channel Models” July 2015
- [45] 3GPP ”Study on channel model for frequency spectrum above 6 GH”3GPP TR 38.900 V15.0.0 (2018-06)
- [46] “MiWEBA project homepage <http://www.miweba.eu> (FP7-ICT-2013-EU-Japan, project number: 608637),” 2015
- [47] ITU-R propagation prediction methods for interference and sharing studies ITU 2012 Handbook
- [48] <https://wireless.engineering.nyu.edu/long-range-models/>
- [49] Jason D. Hintersteiner ”What You Need to Know About 802.11ad and 802.11ay” WLPC 2019

-
- [50] <https://www.nist.gov/system/files/documents/ct1/5G-Millimeter-Wave-Channel-Model-AllianceV2.pdf>
- [51] <https://5g-ppp.eu/mmmagic/>
- [52] Minimum Requirements Related to Technical Performance for IMT-2020 Radio Interface(s), document ITU-R M. [IMT-2020.TECH PERFREQ], Oct. 2016.
- [53] H. J. Liege, “An updated model for millimeter wave propagation in moist air,” *Radio Sci.*, vol. 20, no. 5, pp. 1069–1089, 1985.
- [54] E. K. Smith, “Centimeter and millimeter wave attenuation and brightness temperature due to atmospheric oxygen and water vapor,” *Radio Sci.*, vol. 17, no. 6, 1982.
- [55] F. K. Schwering, E. J. Violette, and R. H. Espeland, “Millimeter wave propagation in vegetation: Experiments and theory,” *IEEE Trans. Geosci. Remote Sens.*, vol. 26, no. 3, pp. 355–367, May 1988.
- [56] T. S. Rappaport, G. R. Maccartney, M. K. Samimi, and S. Sun, “Wideband millimeter-wave propagation measurements and channel models for future wireless communication system design,” *IEEE Trans. Commun.*, vol. 63, no. 9, pp. 3029–3056, Sep. 2015.
- [57] T. S. Rappaport, G. R. Maccartney, M. K. Samimi, and S. Sun, “Wideband millimeter-wave propagation measurements and channel models for future wireless communication system design,” *IEEE Trans. Commun.*, vol. 63, no. 9, pp. 3029–3056, Sep. 2015.
- [58] T. Rappaport et al., “Broadband millimeter-wave propagation measurements and models using adaptive-beam antennas for outdoor urban cellular communications,” *IEEE Trans. Antennas Propag.*, vol. 61, no. 4, pp. 1850–1859, Apr. 2013.
- [59] T. Bai, R. Heath, “Coverage and Rate Analysis for Millimeter Wave Cellular Networks,” *IEEE Transactions on Wireless Communications*, vol. 14, no. 2, pp. 1100–1114, Feb. 2015.

-
- [60] Path loss models for 5G millimeter wave propagation channels in urban micro-cells, in 2013 IEEE Global Communications Conference (GLOBECOM), Dec. 2013, pp.3948–3953.
- [61] K. Haneda et al., “Frequency-agile path loss models for urban street canyons,” IEEE Transactions on Antennas and Propagation, vol. 64, no. 5, pp. 1941-1951, May 2016.
- [62] <https://www.rfwireless-world.com/5G/5G-NR-RSRP-RSRQ-SINR-measurements.html>
- [63] <https://www.digi.com/support/knowledge-base/understanding-LTE-signal-strength-values>
- [64] 3GPP Technical Specification TR 25.912,” Feasibility study for evolved Universal Terrestrial Radio Access (UTRA) and Universal Terrestrial Radio Access Network (UTRAN) (3GPP TR 25.912 version 8.0.0 Release 8)”, Technical Report 2009-01.
- [65] E. Dahlman and S. Parkvall, “NR - The new 5G radio-access technology,” 2017
- [66] <https://naijaquest.com/best-airports-in-africa/>