

ADDIS ABABA UNIVERSITY
ADDIS ABABA INSTITUTE OF TECHNOLOGY
SCHOOL OF GRADUATE STUDIES

**A FINITE ELEMENT METHOD BASED ANALYSIS OF
CORBELS**

By
Finotework Asnake

November 2016

Addis Ababa

**A FINITE ELEMENT METHOD BASED ANALYSIS OF
CORBELS**

Finotework Asnake

A Thesis Submitted to

The School of Graduate Studies of Addis Ababa University

**in Partial Fulfillment of the Requirements for the Degree of
Master of Science in Structural Engineering**

Addis Ababa University

Addis Ababa, Ethiopia

November 2016

ADDIS ABABA UNIVERSITY
ADDIS ABABA INSTITUTE OF TECHNOLOGY
SCHOOL OF GRADUATE STUDIES

This is to certify that the thesis prepared by Finotework Asnake, entitled: *A Finite Element Method Based Analysis of Corbels* and submitted in partial fulfillment of the requirements for the Degree of Master of Science in Structural Engineering complies with the regulations of the University and meets the accepted standards with respect to originality and quality.

Approved by Board of Examiners

<u>Dr. Shifferaw Taye</u>	_____	_____
Advisor	Signature	Date
<u>Dr.-Ing. Girma Zerayohannes</u>	_____	_____
External Examiner	Signature	Date
<u>Dr.-Ing. Bedilu Habte</u>	_____	_____
Internal Examiner	Signature	Date
<u>Dr. Agizew Nigussie</u>	_____	_____
Chairman	Signature	Date

DECLARATION

I, the undersigned, declare that the thesis is my original work, and has not been presented for a degree in any other university and that all sources of materials used for the thesis have been duly acknowledged.

Name: Finotework Asnake

Signature: _____

Place: Addis Ababa University

Institute of Technology

Addis Ababa

Date: November, 2016

ABSTRACT

In view of the increasing need of industry and infrastructure these days, finding the structural element that capable of transferring high load are critical. Corbels are widely used in concrete structures in view of the advantages such as transferring high load to the supporting. Yielding of tension tie, failure of end anchorage of the tension tie, failure of concrete by compression or shearing and bearing failure are the main contribution to failure of reinforced concrete corbels. Thus, stress analysis and parametric study has become popular as an area of research on corbels to minimize the failure and optimal design of corbels.

This thesis presents a parametric study of the behavior of reinforced concrete corbels using finite element analysis software ANSYS. The parameters taken into consideration has been geometry of a corbel (width, thickness, outside edge depth and shear span to effective depth ratio), concrete strength, reinforcement ratio, loading condition (uniform, line and concentrated load) and type of modeling (2D and 3D). These variables have been used to conduct a series of finite element analyses for the purpose of achieving the objective of this thesis. Finally, the result obtained from the finite element analysis has been presented and compared with a strut and tie model.

Conclusions were then made concerning the effects of adjusting the parameters of the model. By increasing thicknesses, width, and outside edge depth of RC corbels, both the deflection and the principal stress have been reduced. As the shear span to effective depth ratio increase, the deflection and principal stress also increased. Corbels subjected to loading condition varies from uniformly distributed to concentrated, there were a significant reduction in the principal stress. And also the results showed that modeling using two dimensional approach gives lower values of stress and deflection than a full three dimensional model. A comparison of principal stress showed that the solutions based on finite element analysis deviated slightly from the strut and tie model.

Key words: Corbels, Finite Element, Strut and Tie Model

ACKNOWLEDGMENTS

I would like to express sincere gratitude to my advisor Dr. Shifferaw Taye for his valuable suggestions and clarifications with all doubts I have encountered during the entire research work. His valuable advice, encouragement, sincerity, very humble way of approach which is never been forgotten throughout my life.

Next, I have no words to express my warm feeling and appreciation to my mother for profound encouragement and enormous assistance in all years of my life.

TABLE OF CONTENTS

LIST OF FIGURES	v
LIST OF TABLES	vi
NOTATIONS	vii
1. INTRODUCTION	1
1.1 BACKGROUND	1
1.2 OBJECTIVE OF THE STUDY	2
1.3 METHODOLOGY	2
1.4 SCOPE AND LIMITATION	3
1.5 THESIS OUTLINE	3
2. LITRATURE REVIEW	4
2.1 INTRODUCTION	4
2.2 DESIGN METHODS OF CORBELS	4
2.2.1 Shear Friction Method	4
2.2.2 Strut and Tie Method	6
2.2.3 Finite Element Method	9
2.2.4 Code Provsions for Corbel Design	14
3. FORMULATION OF FINITE ELEMENT METHOD	15
3.1 FORMATION OF STRUCTURE MATRICES	15
3.2 DEVELOPMENT OF ELEMENT STIFFNESS MATRIX	15
3.3 VIRTUAL STRAIN ENERGY	16
3.4 VIRTUAL WORK OF EXTERNAL FORCES	16
3.5 THE GOVERNING EQUATION	17
3.6 DISPLACEMENT FUNCTION	17
3.7 THE STIFFNESS MATRIX [K]	18
4. STRUCTURAL IDEALIZATION AND PARAMETRIC STUDY	20
4.1 DESCRIPTION OF THE MODEL	20
4.2 FINITE ELEMENT IDEALIZATION	21

4.3 FINITE ELEMENT MODELING	22
4.3.1 Two Dimensional Plane Stress Model	23
4.3.2 Three Dimensional Solid Element	23
4.3.3 Reinforcement Idealization	24
4.4 MESHING	25
4.5 PARAMETRIC STUDY	26
4.6 SCOPE AND LIMITATION OF THE MODEL.....	27
4.7 STRUT AND TIE MODEL EXAMPLE.....	28
5. ANALYSIS OF RESULT	34
5.1 GENERAL	34
5.2 EFFECT OF CHANGE IN GEOMETRY	34
5.3 EFFECT OF CHANGE IN CONCRETE STRENGTH	38
5.4 EFFECT OF CHANGE IN REINFORCEMENT RATIO	39
5.5 EFFECT OF CHANGE IN LOADING CONDITION	40
5.6 EFFECT OF CHANGE IN TYPE OF MODELING	42
5.7 COMPARISON OF STM AND FEM	44
5.8 SUMMARY OF THE ANALYSIS RESULTS	48
6. CONCLUSION AND RECOMMENDATION	50
6.1 CONCLUSION	50
6.2 RECOMMENDATION	51
REFERENCE	52
APPENDIX	
APPENDIX A- PLANE 183	A-1
APPENDIX B- SOLID 186	B-1
APPENDIX C- LINK 180	C-1

LIST OF FIGURES

Fig. 4.1 Corbel model	20
Fig. 4.2 Three dimensional model of SOLID 186	24
Fig. 4.3 Corbel with preliminary dimension	28
Fig. 4.4 Strut-and-tie model of a corbel for the loading and dimensions	29
Fig. 5.1 Displacement resultant with variable outside edge depth	35
Fig. 5.2 Maximum principal stress with variable outside edge depth	35
Fig. 5.3 Displacement resultant with variable shear span to effective depth ratio	36
Fig. 5.4 Maximum principal stress with variable shear span to effective depth ratio	36
Fig. 5.5 Displacement resultant with variable width	37
Fig. 5.6 Maximum principal stress with variable width	37
Fig. 5.7 Displacement resultant with variable thickness	38
Fig. 5.8 Maximum principal stress with variable thickness	38
Fig. 5.9 Displacement resultant with variable concrete strength	39
Fig. 5.10 Maximum principal stress with variable concrete strength	39
Fig. 5.11 Displacement resultant with variable loading condition	41
Fig. 5.12 Maximum principal stress with variable loading condition	41
Fig. 5.13 Displacement resultant with variable modeling type	43
Fig. 5.14 Maximum principal stress with variable modeling type	43
Fig. 5.15 Maximum principal stress with different analyzing method	44
Fig. 5.16 Contour plot of displacement resultant for 3D model	45
Fig. 5.17 Contour plot of principal stress for 3D model	45
Fig. 5.18 Contour plot of nodal stress for 2D model	46
Fig. 5.19 Vector plot of principal stress for 2D model	46
Fig. 5.20 Contour plot of displacement resultant for LINK180 element	47
Fig. 5.21 Contour plot of principal stress for LINK180 element	47
Fig. A1 PLANE183 Geometry	A-1
Fig. A2 PLANE183 Stress output	A-3
Fig. B1 SOLID186 Homogeneous structural solid geometry	B-1
Fig. B2 SOLID186 Homogeneous structural solid stress output	B-3
Fig. C1 LINK180 Geometry	C-1
Fig. C2 LINK180 Stress output	C-2

LIST OF TABELS

Table 4.1 Form of material properties	20
Table 4.2 Range of input parameters in the model	27
Table 4.3 Summary of results of analyzing corbel by strut and tie model	33
Table 5.1 Summary of results of analyzing corbel with different reinforcement ratio ...	40
Table 5.2 Comparison of displacements and principal stresses in 2D and 3D model	42
Table 5.3 Comparison of maximum compression principal Stresses in FEM and STM	44

NOTATIONS

F_u	largest factored force
F_n	nominal strength of the strut or node
F_i	force in the strut or tie,
θ	inclination of the inclined strut
A_{vf}	area of shear reinforcement
μ	shear friction coefficient
$\{F\}$	total imposed loading vector
$[K]$	overall stiffness matrix
$\{\delta\}$	overall displacement vector
$\{q\}$	column matrix of internal displacements at a point in the element
$\{Q\}$	column matrix of displacements of the nodal points
$[N]$	shape function
$\{e\}$	total strain
$[B]$	strain displacement transformation matrix
$\{\mathcal{E}\}$	elastic strain
$\{\mathcal{E}_0\}$	initial strain due to temperature change, pre-stress
$\{\sigma\}$	column matrix of stresses
$[D]$	square matrix of elasticity coefficients
δU	virtual strain energy
δW	virtual work of all external forces
$[k]$	element stiffness matrix
$\{\delta_e\}$	vector nodal displacement
E	modulus of elasticity of steel
ν	Poisson's ratio
f_{cd}	design compressive strength of concrete
f_{ck}	characteristic cylinder compressive strength of concrete
f_y	yield stress
f_{yk}	characteristic strength of the reinforcement

γ_c	partial safety factor for concrete
γ_s	partial safety factor for reinforcing steel
a	shear span
d	effective depth
a/d	shear span to effective depth ratio
d_1	outside edge depth of corbel
b	width of corbel
t	out of plane width (thickness) of corbel
h	overall depth of corbel
V	vertical load
V/H	vertical to horizontal load ratio
usum	displacement sum vector
FEM	finite element method
STM	strut and tie model

This page intentionally left blank

1. INTRODUCTION

1.1 BACKGROUND

A corbel is a short, stocky cantilever member that transfer load from a beam to an adjoining member such as a column or wall. Corbels fall under the broader term of non-flexural members. Deep beam, pile caps, steeped joints, and nibs also belong to this category. When a non-flexural member is subjected to increasing load, plane sections do not remain plane, and a non-linear strain distribution develops [7].

Corbels are extensively used in the precast concrete industry. The most common function of a corbel is to enable transfer of load from a beam, to a column. It is usually constructed monolithically with the column.

The shear span to effective depth ratio is often less than unity. Owing to their geometric proportions, corbels are commonly classified as a discontinuity region (D-region), where the strain distribution over their cross section depth is nonlinear, even in the elastic stage, and their strength is predominantly controlled by shear rather than flexure. The analysis and design of these corbels and other non-flexural members, like dapped ended beams, deep beams, pile caps and openings in slabs, becomes difficult with ordinary flexural analysis as the true behavior of the member can't be predicted with the ordinary flexure theory. In the past many structural analysis approaches have been developed to address the various problems faced in real life. Some of the advanced features include the non-linear stress analysis, shear friction method, finite element method, and so on. Further to this the strut-and-tie modeling has been developed as an alternative structural analysis method to address regions of discontinuity. As the complex nature of the stress distribution in D-region particularly in corbels, advanced, clear and more accurate analysis procedure is required to better understand of stress distribution.

Reinforced concrete corbels are generally known to display several modes of failure [7], such as anchorage failure or yielding of main longitudinal reinforcement, shear splitting at the interface between column and corbel, diagonal splitting or crushing of the concrete strut joining the loading point and bottom point of the interface, and local crushing failure under the bearing plate of the applied load.

1.2 OBJECTIVE OF THE STUDY

In the design of structures, the analysis of sections is carried out in order to give a realistic assessment of the stress distributions and hence the required strengths that are necessary to make the structure safe for use. In reinforced concrete corbels, there is a problem of failure of end anchorage of the tension tie, yielding of tension tie, failure of concrete by compression or shearing and bearing failure because of the inadequate strength and detailing. This can be avoided or minimized by proper method of analysis and modification of the different corbel parameters. Therefore, identifying and understanding the factors that affect the performance of reinforced concrete corbels is an important issue for safe design. The finite element method should be able to isolate more conveniently these specific parameters for study.

Thus, the main objective of this thesis are to conduct a parametric study to establish the effects of different input parameters on the behavior of reinforced concrete corbels using existing finite element software package ANSYS.

Specific objective

1. To Model corbel using existing finite element software package ANSYS;
2. To conduct a parametric study of change in geometry, reinforcement ratio, concrete strength, loading condition and modeling type on the behavior of reinforced concrete corbels;
3. To perform a stress analysis using ANSYS software and compare the result with a strut and tie model.

1.3 METHODOLOGY

Appropriate analysis and design detailing for reinforced concrete corbels are required due to the high transferred loads from the crane and precast elements which rested on corbels. To achieve the above objective, use the following methodology. A parametric study on the behavior of corbels was carried out using finite element method. In finite element method the general purpose software ANSYS was used to model and analysis corbels. By considering different loading condition, concrete strength, reinforcement ratio, modeling type and geometric proportion of corbels, parametric study has been made. Following the finite element analysis conclusion and when results were in hand,

an analytical analysis was carried out using strut and tie model with the help of Excel sheets. Different literatures related to the problem at hand were reviewed and incorporate to supplement the study. Based on the output, conclusion and recommendation has been made.

1.4 SCOPE AND LIMITATION

This thesis work should concentrate on the analysis of reinforced concrete corbels for various parameters. The analyses were to be carried out in the finite element program ANSYS, with its implemented features, such as the material models for concrete and steel. This study is helpful as a guide for researcher and structural engineers to better understanding of stress development in the corbels and lead to in preparing suitable practical guidelines for design and simple analysis. The analysis was carried out based on the numerical and analytical methods rather than experimental.

1.5 THESIS OUTLINE

This thesis is organized into six chapters. Chapter 1 is an introduction to the topic followed by the statement of the problem, objectives, methodology and scope of the study. A literature review of the different methods of analyzing reinforced concrete corbels is presented in Chapter 2. Chapter three is about the general finite element method formulation. Formation of structure matrices, development of element stiffness, deriving displacement function and solving equation is briefly described. Chapter 4 is about the structural idealization of corbels and description of the parameters. Modeling and analysis of corbels by considering different parameters using finite element general purpose software, ANSYS has been dealt. In chapter 5, the computer output and its physical interpretation are presented in graphical and tabular form with the help of Excel spread sheet. Chapter 6 provides the conclusion obtained from this work and suggests future work in this area.

2. LITERATURE REVIEW

2.1 INTRODUCTION

Until the 1960's, corbels were designed as short cantilevers using the shear and flexural provisions derived for beams of normal proportions. This is surprising as these procedures were not considered applicable to deep beams which have much in common with corbels. The 1960's saw the development of two new methods of corbel design. The Americans introduced two empirically based methods while the Europeans developed approach based on the truss analogy. With the rapid expansion of research in to the design and behavior of corbels, it became clear that many corbels failed prematurely due to inadequate methods of detailing. In this year, various standard detailing procedures were developed, particularly in the areas of main steel anchorage, bearing pad size and placement, and the provision of secondary reinforcement. While the Americans are still in favor of an empirically based design approach, the truss analogy method of design has become increasingly accepted elsewhere. The present state of the art application of the truss analogy incorporates the use of plasticity theory in combination with a simple strut and tie model [7].

2.2 DESIGN METHODS OF CORBELS

There are various approaches for the design of disturbed regions like corbels such as Strut and Tie Model (STM), shear friction method and finite element method. These methods are described briefly in this chapter.

2.2.1 Shear Friction Method

The shear friction concept provides a convenient tool for the design of members for direct shear where it is inappropriate to design for diagonal tension, as in precast connections, and in brackets and corbels. The concept is simple to apply and allows the designer to visualize the structural action within the member or joint. The approach is to assume that crack has formed at an expected location. As slip begins to occur along the crack, the roughness of the crack surface forces the opposing faces of the cracks to separate. This separation is resisted by reinforcement (A_{vf}) across the assumed crack. The tensile force ($A_{vf}f_y$) developed in the reinforcement by this strain induces an equal and opposite nominal clamping force, which in turn generates a frictional force ($A_{vf}f_y\mu$)

parallel to the crack to resist further slip [2]. In this section a brief review of previous studies about the application of the shear friction method for design of reinforced concrete corbels is presented.

Kriz and Raths [9] undertook an extensive experimental study into the behavior of reinforced concrete corbels. The purpose of the study was directed towards the development of design criteria for corbels. For their experimental work, 195 corbels were tested, of which 124 were loaded vertically while the remaining 71 corbels were loaded both vertically and horizontally. The main findings were, the corbel strength was significantly reduced by horizontal forces acting outward from the column, and the strength of a corbel subjected to vertical loads only can be increased by adding extra tension reinforcement or horizontal stirrups until a maximum amount of reinforcement is reached. The strength decreases as the (a/d) ratio increases and increases as the main reinforcement ratio (ρ) increases.

Mattock [16] conducted experimental research relating to shear transfer in concrete. He showed that shear friction theory can be extended to include the case of concrete with reinforcement at an angle to the shear plane. Mattock proposed a flexural model which considers the corbel as a free body cut from the corbel-column interface. The corbel is designed to resist a combination of vertical and horizontal loads using the laws of statics. The variables studied were shear span to effective depth ratio, (a/d) , vertical to horizontal loads ratio, (V/H) , the amount of main reinforcement and secondary reinforcement (stirrups) and the type of aggregate.

Hermansen and Cowan [19] proposed the modified shear-friction theory. They assumed that when a crack forms on the shear plane the reinforcement crossing the crack is stressed to yield. The major conclusion reached by Hermansen and Cowan is that specimen with single corbel (exterior corbel) showed no significant difference in behavior in comparison to those with double corbels (interior corbel). Hermansen and Cowan's design method called for the design of three main modes of failure. These modes of failure included shear failure, flexural failure, and secondary failure (anchorage, bearing).

2.2.2 Strut and Tie Models

Strut-and-tie models are most appropriately used for the design of disturbed regions, or D-regions. These D-regions are characterized by a complex flow of internal stresses and include regions adjacent to discontinuities caused by abrupt changes of cross section or the presence of concentrated loads or reactions (corbels, deep beams, dapped-end beams, and anchorage zones at the end of prestressed beams). In the design of these disturbed regions, it is inappropriate to assume that plane sections remain plane or that the shear stress is uniform over the depth of the member, therefore the standard design rules for flexure and shear do not apply. ACI 318 codes [2] permitted the use of strut-and-tie models for the design of discontinuity regions. In STM, a load resisting truss is idealized to carry the forces through the D-region to its supports. The shape of the load resisting truss and its selection depends on the experience of designer, who is free to choose the shape of the load resisting truss with only limited guidance and constraints. The structure is assumed to be sufficiently ductile so that the load is supported in the same fashion as envisioned by the designer and no part of the truss is over stressed. The compression members of the truss are called Struts, which resist the compression forces and the struts capacities are determined on the basis of equations proposed by ACI 318. These struts are assumed as prismatic, bottle shaped or fan shaped. The tensile members of the truss are called ties, which are reinforced with steel bars. The joints of truss are called Nodes [1].

A design with the strut-and-tie model typically involves the following steps [1]:

1. Define and isolate D-regions.
2. Compute resultant forces on each D-region boundary.
3. Devise a truss model to transfer the resultant forces across the D region. The axes of the strut and ties, respectively, are oriented to approximately coincide with the axes of compression and tension stress field.
4. The forces in the truss member are calculated.
5. The effective widths of the struts and nodal zones are determined considering the forces from the previous steps and the effective concrete strengths. Strength checks are based on $\Phi F_n \geq F_u$
6. Reinforcement is provided for the ties considering the steel strengths defined. The reinforcement is detailed to provide proper anchorage in the nodal zones.

In this section a brief review of previous studies about the application of the strut and tie model for design of reinforced concrete corbels is presented.

Franz and Niedenhoff [17] performed the photo-elastic study of resin model corbels and their goal was to analyze the behavior of corbels under shear load. Their finding shows that the structural action of a corbel resembles that of a simple determinant truss. The truss model consisted of compression struts and tension ties. Their result revealed that, the tensile stress at the upper edge of the corbel is relatively constant from the load to the root of the bracket, an approximately straight strut develops at the compressive face where the stresses are relatively constant, stress concentration were found to develop at the root of the corbel and the shape of the corbel has little influence on the state of the stress within the corbel. While this method has the advantage of simplicity and ease of use, the method proposed by Franz and Niedenhoff does not consider horizontal loads and the cracking which occurs.

Somerville, reported reviews to the available test data and previous design methods on corbels to determine the major parameters that influence its behavior [12]. He suggested an alternative method for enhancing the strength due to (a/d) ratios. Some investigators indicated that truss analogy is not applicable to corbels with low values of (a/d) ratios. Somerville limits the use of truss analogy to values of (a/d) ratios equal or greater than (0.6). Therefore, for determining the shear strength of corbels having low values of (a/d) ratios, alternative approaches have been suggested.

Hagberg [14] devised a truss model using a geometrical method of force distribution. He felt that the advantage of this model were it can effectively predict the capacity of a corbel, it provides a rational basis for corbel detailing and it is suited to computer aided design. And he makes assumption in his model were; failure is caused by yielding of the reinforcement or by crushing of the concrete (shear failure is not considered as a failure criterion), uniaxial tests are used to determine the strength of materials, the concrete strength is equal to the cylinder test strength, the strength of concrete in tension is neglected and the geometry of the corbel shall conform with the mathematical model. The reinforcement is assumed to act as a linear tension member. The effect of dowel action by the reinforcement is ignored. Hagberg believed his design approach to be valid for corbels having a/d ratios between 0.15-1.0, subjected to combinations of vertical and horizontal loads.

Hwang [3] presented a softened strut-and-tie model for determining the shear strength in corbels. 178 test specimens from literature were used for comparison with the proposed method. The studied corbels have various parameters, such as (a/d) ratios, different strength categories and horizontal reinforcement. The predictions of the ACI empirical equations were found to be conservative for the selected test data and more pronounced conservatism was found for corbels with low (a/d) or those made with high-strength concrete. It is thus confirmed that vertical stirrups are not useful for shear strength of a corbel with $a/d \leq 1$. In the model proposed by Hwang, it was found that the web reinforcement was efficient in two ways: the first was to form tension ties and provide shear transferring paths; the other was to control the crack widths and retard the softening process of the cracked concrete. As a result, the shear capacity of corbels using the softened strut-and-tie model proposed by Hwang can be obtained, though several assumptions based on linear elastic beam theory are imposed.

Yong [13] performed a study to check the applicability of the ACI 318 Code and the truss analogy theory, proposed by Hagberg, on reinforced concrete corbels with concrete strength greater than 41.4 MPa. A total of eight high strength concrete corbels, divided into four series with concrete strength ranging from 41.7 MPa to 82.7 MPa and the shear span to depth ratio, (a/d), was equal to 0.393. The corbels were loaded monotonically to failure. The researchers in this paper concluded that the ACI 318 code provisions are conservative for high strength concrete. In addition to the above, the truss analogy model predicted values were safe and less conservative than the ACI Code. But they concluded that this conservatism of the ACI Code may not necessarily be found in corbels with larger (a/d) ratios or subjected to horizontal loads in addition to the vertical loads.

Singh [10] presented a complete example on the analysis and design of a double corbel using the strut-and-tie method. The purpose was to amplify the application of the practical recommendations given by the ACI 318 Code regarding the design of structural members using the strut-and-tie method. The strut-and-tie method of design is based on the assumption that appropriate regions in concrete structures can be analyzed and designed using hypothetical pin-jointed trusses consisting of struts and ties connected at nodes.

2.2.3 Finite Element Method

The rapid development of computers has completely revolutionized research and practice in every scientific and engineering field. The dream that every office and home would have a computer terminal and personal computers has become a reality. Since the 1990s personal computers have become as popular as pocket calculators were in the 1970s and slide rules in the 1950s. Following this trend, analysis and design methods that provide computerized solutions to scientific and engineering problems have been developing rapidly for increasingly routine use [5]. In this paper, focus on one such significantly developed method, the finite element method.

The concept of the finite element method was originally introduced for structural analysis by Turner, Argyris and Kelsey in the mid-50's. The name finite element was originally coined in a paper by Clough in 1960, in which the technique was presented for plane stress analysis. Since then general progress has been so rapid that the method is now one of the most powerful tools available in structural analysis. It has also been recognized as a general numerical method for approximately solving various systems of partial differential equations with known boundary conditions. Thus its application covers a wider range of physical problems other than structural. For instance, problem arising in such fields as fluid mechanics, electro-dynamics, temperature fields, and from one dimensional problem to three dimensional problems can be solved [8].

The method is a general discretization procedure for solving continuum problems defined by certain classes of mathematical statements. The continuum is subdivided into finite regions termed elements, each of which possesses a finite number of unknown parameters which approximate the values of the field variables which define the problem. These field variables may be scalars, vectors, or high order tensors. These elements connect with each other through common points existing on their boundaries at which continuity and compatibility of the field variables are enforced. These common points are termed nodes. A set of functions are chosen to define the variation of the required field variable within each element in terms of the unknown nodal values. In structural mechanics problems, the unknown field variables can be displacements, stresses, or both. This gives rise to the displacement (stiffness) method, the force (flexibility) method, or the hybrid method respectively. The displacement method is the most widely used because of its relative ease of formulation compared to the other

methods [8]. This study uses the displacement method. Thus for each element, a standard set of simultaneous equations can be formulated to relate these physical quantities. Physically assembling these elements to form the whole structure is equivalent to superimposing these element equations mathematically. The result is a large set of simultaneous equations, which are suited for solution by computer. Upon implementing the loading and boundary conditions for structural problems, the assembled set of equations can be solved and the unknown parameter found. Substituting these values back to each element formulation provides the distributions of stress and displacement everywhere within each element. This solution procedure is called finite element analysis (FEA).

The finite element method is unique in the way it can formulate the properties of individual elements of any type of problem. One of its main attractions is the ease with which it can be applied to problems with geometrically complicated boundaries [8]. The price that must be paid for this flexibility is in the amount of numerical computation required. Usually a large number of simultaneous equations have to be solved; if more elements and nodes are included for increased accuracy, then more equations will result. A number of popular brand of finite element analysis packages are now available commercially. Some of the popular packages are STAAD/PRO, GT-STRUDEL, NASTRAN, LISA, ABACUS and ANSYS. Using these packages one can analyses several complex structures. In this section a brief review of previous studies about the application of the finite element method for linear and nonlinear analysis of reinforced concrete corbels is presented.

Prasad [11] analyzed reinforced concrete corbels using the nonlinear finite element method. The analysis indicated that the method may be used to predict the response of reinforced concrete structures. Details regarding orientation and distribution of cracks as well as stresses in concrete and steel at various locations may be obtained and studied. The finite element approach is regarded as a feasible method of analysis and design especially with the increasing of experimental costs and the decreasing of computational costs.

Rezaei [15] investigated the effect of column-load on corbels. Single and double corbels with different levels of axial column load were modeled and analyzed by means of finite element software computer package. The axial load capacity of the column was first

determined, and then the load was applied on top of the column increasing gradually until reaching the predetermined level, after that, the load was applied on the corbels until failure was achieved. It was found that the strength of double corbels was more influenced than that of single ones due to the axial column load. The latter was found to enhance the stiffness of corbels.

A nonlinear finite element approach was implemented, in the same year, by Yousif [18] to study the behavior of high strength reinforced concrete corbels using a simplified softened strut-and-tie model. The analysis was based on truss analogy, following the provisions of Appendix A of the ACI 318 Code. Different parameters such as a/d , primary and secondary reinforcement ratios and concrete compressive strength have been studied. The study showed that the finite element method was a suitable tool for the analysis of high-strength concrete corbels, and that the strut-and-tie model was a simple and effective design tool that may give reasonable predictions of the failure load capacity of high strength reinforced concrete corbels.

Basic step in the finite element method[4]

1. Selection of element type and discretization of the continuum

The first step is to decide on the type of element to be used, and then to subdivide the continuum or solution region into a suitable number of elements with associated nodes. In general the following points are considered in element selection:

i. Element type

The selection of the element will be related to the type of problem to be solved. Generally it can be grouped as plane stress/plane strain/Axisymmetric, plate bending, shells and three dimensional (solid analysis). In each group different levels of accuracy can be obtained. This depends on the number of nodal points and corresponding degrees of freedom which are associated with the element type. Nodal points are usually placed on the boundaries of the elements, although internal nodes can also be included in certain elements in order to increase efficiency. Usually the higher the order of element, the more accurate and expensive it.

ii. Element size

In general the finer the mesh the better the accuracy, but at the same time the larger the computational effort required. The number of elements to be used will be decided by the type of structure to be analysed, but generally more elements are required in regions where stresses vary rapidly than in regions where they vary gradually.

iii. Element aspect ratio

The aspect ratio for two dimensional elements is defined as the ratio of largest dimension of the element to the smallest dimension. The optimum aspect ratio at any location within the mesh depends upon the difference in rate of change of displacement in different directions.

2. Shape function

A shape function is the variation of field variable, and its derivatives, through an element in terms of its values at the nodes. Therefore shape functions are closely related to the number of nodes and hence type of element. Often polynomials are selected as shape functions because they are relatively easy to manipulate mathematically, particularly with regard to integration and differentiation. However, the degree of polynomial chosen will depend on the number of nodes and the degree of freedom associated with the elements.

3. Element properties

After establishing the finite element model (i.e., once the element type and its shape function have been selected) , element properties have to be determined. These are expressed in terms of matrices and related to the nodal parameters and material properties of the element. Some common matrices are the strain and stress matrices which define the strain and stress respectively at specific points in the element in terms of its nodal displacements, the elasticity matrix which is used to relate stresses to strains at certain point, and so on. Some of these matrices combine to define the stiffness matrix which forms part of the basic equation governing the overall behavior of the element. This equation expresses the relation between displacements and forces at element nodes in terms of the element stiffness.i.e.,

$$\{F\}^e = [k]^e \{\delta\}^e \quad (2.1)$$

where, $\{F\}^e =$ vector of unknown element force

$[k]^e =$ element stiffness matrix

$\{\delta\}^e =$ vector of unknown displacement

This equation is general and valid for all element.

4. Assembly of element properties

Element properties have to be assembled to express the behavior of the entire solution region. In the structural displacement method, the assembly process is based on the laws of compatibility and equilibrium. It is required that the body remains continuous. Also displacement of two adjacent points must have identical values for compatibility to be satisfied. The matrix equation for the system has the same form as the equations for an individual element except that they now contain terms associated with all nodes. This equation is then modified to take in to account any boundary condition of the problem. These are the physical constraints or supports that must exist so that the structure or continuum has a unique solution.

5. Solution of the system of equation

The equations assembled have the form:

$$\{F\} = [K] \{\delta\} \quad (2.2)$$

where $\{F\}$, $[K]$ and $\{\delta\}$ are total imposed loading vector, the overall stiffness matrix and overall displacement vector respectively.

These equation are solved for the unknown variables by using either a direct solution method (i.e. Gauss elimination,...) or an iterative method (i.e. Gauss-seidal,...).

6. Final calculation

After solving the equations, a complete solution of the problem is obtained by evaluating quantities depending on the solved unknown field variables. That means in stress analysis, calculation of strains follow from calculation of the unknown nodal displacement and hence stresses can be calculated.

2.2.4 Code Provisions for Corbel Design

In the USA, much of the research material relating to corbel design has been of an empirical or semi-empirical nature. Accordingly, the ACI318 design approach to corbels has been based on empirical or semi-empirical method. In Europe, where the literature has favoured the truss-analogy that is a strut-and-tie model approach. Similarly in Ethiopia, EBCS code have tended towards this method of design. Strut and tie modeling of reinforced concrete structures is used in the design of discontinuous or d-region like corbels. For those regions, shear is the critical mode of failure and EBCS 2 allows for its design using strut and tie models (STM). However EBCS 2 provides very little guidance in using strut and ties models, which covers mainly the effective concrete strength provisions for the various strut and tie elements and the codes lacks extensive coverage of the STM design procedures for different cases.

3. FORMULATION OF FINITE ELEMENT METHOD

3.1 FORMATION OF STRUCTURE MATRICES

A structural model assembled from a finite number of discrete elements is substituted for the continuous structure. These elements are separated by imaginary lines and are interconnected by a finite number of nodes. The equations of elasticity for the continuous structure are formulated in matrix form using these elements.

3.2 DEVELOPMENT OF ELEMENT STIFFNESS MATRIX

In the finite element analysis it is assumed that the displacements at any point within the element can be related to the displacements at the nodes by using function. This function which relates the field variable at any point within the element to the field variables of nodal points is called shape function or interpolation function. And in equation form:

$$\{q\} = [N]\{Q\} \quad (3.1)$$

With the displacements at any point within the element given, the corresponding total strains are obtained by differentiating Equation (3.1)

$$\{e\} = [B] \{Q\} \quad (3.2)$$

$$= \{\mathcal{E}\} + \{\mathcal{E}_0\} \quad (3.3)$$

Assuming linear elastic behavior for material, the stresses are related to the elastic strains by generalized Hooke's Law:

$$\{\sigma\} = [D] (\{e\} - \{\mathcal{E}_0\}) \quad (3.4)$$

Substituting Equation (3.2) in to Equation (3.4) gives

$$\{\sigma\} = [D][B]\{Q\} - [D] \{\mathcal{E}_0\} \quad (3.5)$$

For virtual nodal displacements $\delta\{Q\}$, the corresponding virtual displacements at any point within the element are obtained from Equation (3.1).

$$\delta\{q\} = [N] \delta\{Q\} \quad (3.6)$$

and from equation (3.2) the virtual strains become

$$\delta\{\boldsymbol{\varepsilon}\} = \delta\{\mathbf{e}\} = [\mathbf{B}] \delta\{\mathbf{Q}\} \quad (3.7)$$

the governing finite element equations for unit length of the structure will be developed from a consideration of the principle of virtual work which takes the form:

$$\delta U = \delta W \quad (3.8)$$

3.3 VIRTUAL STRAIN ENERGY

The strain energy maybe expressed as

$$U = \int_v U_0 \, dv \quad (3.9)$$

If now, virtual displacements are imposed on the structure, there will be accompanying virtual strains and the variation of the strain energy density will be given by:

$$\delta U_0 = \delta \{\boldsymbol{\varepsilon}\}^t \{\boldsymbol{\sigma}\} \quad (3.10)$$

Consequently, the variation of the strain energy will be

$$\delta U = \int_v \delta U_0 \, dv = \int_v \delta \{\boldsymbol{\varepsilon}\}^t \{\boldsymbol{\sigma}\} \, dv \quad (3.11)$$

Substitution of Equations (3.5) and (3.7) in to Equation (3.11) yields

$$\delta U = \int_v \delta \{\mathbf{Q}\}^t ([\mathbf{B}]^t [\mathbf{D}] [\mathbf{B}]) \{\mathbf{Q}\} \, dv - \int_v \delta \{\mathbf{Q}\}^t [\mathbf{B}]^t [\mathbf{D}] \{\boldsymbol{\varepsilon}_0\} \, dv \quad (3.12)$$

3.4 VIRTUAL WORK OF EXTERNAL FORCES

The structure is assumed to be subjected to a system of surface forces $\{\mathbf{T}\}$, body forces $\{\mathbf{X}\}$, and a set of concentrated forces $\{\mathbf{P}\}$ applied at the nodes interconnecting the boundaries of the elements. The virtual work of external forces, due to virtual displacements at the nodes, is then given by:

$$\delta W = \int_v \delta \{\mathbf{q}\}^t \{\mathbf{X}\} \, dv + \int_s \delta \{\mathbf{q}\}^t \{\mathbf{T}\} \, ds + \delta \{\mathbf{Q}\}^t \{\mathbf{P}\} \quad (3.13)$$

Substitution of Equation (3.6) in to (3.13) yields

$$\delta W = \int_v \delta \{\mathbf{Q}\}^t [\mathbf{A}]^t \{\mathbf{X}\} \, dv + \int_s \delta \{\mathbf{Q}\}^t [\mathbf{A}]^t \{\mathbf{T}\} \, ds + \delta \{\mathbf{Q}\}^t \{\mathbf{P}\} \quad (3.14)$$

3.5 THE GOVERNING EQUATION

Equating the Equation (3.12) and (3.14) as required by Equation (3.8) results in

$$\begin{aligned} & \int_v \delta \{Q\}^t [B]^t [D] [B] \{Q\} dv - \int_v \delta \{Q\}^t [B]^t [D] \{\epsilon_0\} dv \\ & = \int_v \delta \{Q\}^t [A]^t \{X\} dv + \int_s \delta \{Q\}^t [A]^t \{T\} ds + \delta \{Q\}^t \{P\} \end{aligned} \quad (3.15)$$

This equation is valid for value of virtual displacements. Hence

$$[k] \{Q\} = \{P\} + \int_v [B]^t [D] \{\epsilon_0\} dv + \int_v [A]^t \{X\} dv + \int_s [A]^t \{T\} ds \quad (3.16)$$

where, $[k] = \int_v [B]^t [D] [B] dv =$ element stiffness matrix.

Addition of these element matrices yields the stiffness matrix for the entire structure. Equation (3.16) then becomes

$$[K] \{Q\} = \{P\} + \int_v [B]^t [D] \{\epsilon_0\} dv + \int_v [A]^t \{X\} dv + \int_s [A]^t \{T\} ds \quad (3.17)$$

where, $[K] =$ structure stiffness matrix

3.6 DISPLACEMENT FUNCTION

In the finite element analysis aim is to find the field variables at nodal points by rigorous analysis, assuming at any point inside the element basic variable is a function of values at nodal points of the element. This function which relates the field variable at any point within the element to the field variables of nodal points is called shape function. In two dimensional stress analyses, in which basic field variable is displacement.

$$u = \sum N_i u_i, \quad v = \sum N_i v_i \quad (3.18)$$

For the case of four node rectangular element the equation becomes

$$u = \sum N_i u_i = N_1 u_1 + N_2 u_2 + N_3 u_3 + N_4 u_4$$

$$v = \sum N_i v_i = N_1 v_1 + N_2 v_2 + N_3 v_3 + N_4 v_4$$

i.e. $\{\delta\} = [N] \{\delta_e\} \quad (3.19)$

3.7 THE STIFFNESS MATRIX [K]

Equation (3.1) is now differentiated to give the total strains any point within the element in Equation (3.2) i.e., $\{e\} = [B] \{Q\}$

The stiffness matrix for each element is given by

$$[k] = \int_v [B]^t [D] [B] dv \quad (3.20)$$

The elasticity matrix [D] in case of isotropic materials, for plane stress

$$[D] = \frac{E}{1-\mu^2} \begin{bmatrix} 1 & \mu & 0 \\ \mu & 1 & 0 \\ 0 & 0 & \frac{1-\mu}{2} \end{bmatrix} \quad (3.21)$$

And for plane strain case

$$[D] = \frac{E}{(1+\mu)(1-2\mu)} \begin{bmatrix} 1-\mu & \mu & 0 \\ \mu & 1-\mu & 0 \\ 0 & 0 & \frac{1-2\mu}{2} \end{bmatrix} \quad (3.22)$$

$$[k] = \iint_{-1}^1 [B]^T [D] [B] t_w |J| ds dt \quad (3.23)$$

$$\begin{array}{l} \text{Coordinate transformation } x = x(s, t) \\ y = y(s, t) \end{array} \quad \longleftrightarrow \quad \begin{array}{l} s = s(x, y) \\ t = t(x, y) \end{array}$$

Jacobian matrix

$$[J] = \begin{bmatrix} \frac{\partial x}{\partial s} & \frac{\partial y}{\partial s} \\ \frac{\partial x}{\partial t} & \frac{\partial y}{\partial t} \end{bmatrix} \quad (3.24)$$

$$[J] = \frac{1}{8} \{x_c\}^T \begin{bmatrix} 0 & 1-t & t-s & s-1 \\ t-1 & 0 & s+1 & -s-t \\ s-t & -s-1 & 0 & t+1 \\ 1-s & s+1 & -t-1 & 0 \end{bmatrix} \{y_c\} \quad (3.25)$$

where, $\{x_c\} = \begin{Bmatrix} x_1 \\ x_2 \\ x_3 \\ x_4 \end{Bmatrix}$, $\{y_c\} = \begin{Bmatrix} y_1 \\ y_2 \\ y_3 \\ y_4 \end{Bmatrix}$

$$[B(s, t)] = \frac{1}{[J]} [B_1 | B_2 | B_3 | B_4] \quad (3.26)$$

$$[B_1] = \begin{bmatrix} a(N_{i,s}) - b(N_{i,t}) & 0 \\ 0 & c(N_{i,t}) - d(N_{i,s}) \\ c(N_{i,t}) - d(N_{i,s}) & a(N_{i,s}) - b(N_{i,t}) \end{bmatrix} \quad (3.27)$$

where, $N_{1,s} = \frac{\partial N_1}{\partial s} = \frac{(t-1)}{4}$ $N_{1,t} = \frac{\partial N_1}{\partial t} = \frac{(s-1)}{4}$

$N_{2,s} = \frac{\partial N_2}{\partial s} = \frac{(1-t)}{4}$ $N_{2,t} = \frac{\partial N_2}{\partial t} = \frac{-(s+1)}{4}$

$N_{3,s} = \frac{\partial N_3}{\partial s} = \frac{(t+1)}{4}$ $N_{3,t} = \frac{\partial N_3}{\partial t} = \frac{(s+1)}{4}$

$N_{4,s} = \frac{\partial N_4}{\partial s} = \frac{-(t-1)}{4}$ $N_{4,t} = \frac{\partial N_4}{\partial t} = \frac{(1-s)}{4}$

$$a = \frac{1}{4} [y_1(s-1) + y_2(-s-1) + y_3(s+1) + y_4(1-s)]$$

$$b = \frac{1}{4} [y_1(t-1) + y_2(1-t) + y_3(t+1) + y_4(-1-t)]$$

$$c = \frac{1}{4} [x_1(t-1) + x_2(1-t) + x_3(t+1) + x_4(-1-t)]$$

$$d = \frac{1}{4} [x_1(s-1) + x_2(-s-1) + x_3(s+1) + x_4(1-s)]$$

Addition of these element matrices in accordance with the nodal numbering of each element yields the stiffness matrix for the entire structure [K].

The body and surface load is given by the equation below.

$$\{ f_b \} = \iint_{-1}^1 [N]^T \{ x_b \} t_w \quad || \quad ds dt \quad (3.28)$$

$$\{ f_s \} = \int_L [N]^T \{ T \} t_w \quad || \quad dL \quad (3.29)$$

4. STRUCTURAL IDEALIZATION AND PARAMETRIC STUDY

4.1 DESCRIPTION OF THE MODEL

As an attempt to do a parametric study on the behavior of corbels, a modeling and stress analysis was carried out. The model used in order to do a parametric study was a corbel having different shear span to effective depth ratio, loading condition, concrete strength, reinforcement ratio and dimension. This model was first modeled by a finite element method and considering different parameters which have affects the behavior of corbels. It was compared the result of finite element method with the code provision in the analysis of corbels, the model was reanalyzed by a strut-and- tie model. The structures were hypothetical and have been chosen for the illustrative purpose.

Assumption- homogenous, isotropic, uncracked linear elastic material property

Table 4.1 Form of material properties

	E (MPa)	ν
Concrete	31000	0.2
Reinforcement	200000	0.3

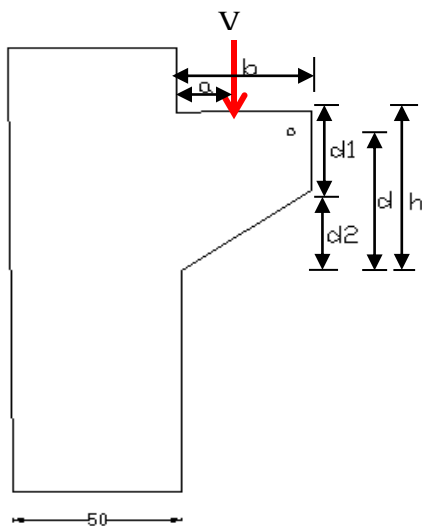

Fig. 4.1 Corbel model

4.2 FINITE ELEMENT IDEALIZATION

In finite element method, modeling of the problem is one of the aspects that govern the accuracy of the solution and efficiency of computational time. An assemblage of two or three dimensional elements can be used for idealization. The number of elements chosen for the assemblage depends on the accuracy desired. With properly formulated finite elements, the result converges to the exact solution with decreasing element size. Accordingly the larger the number of elements the more accurate the solution obtained. In addition the aspect ratio of the elements should be kept near to one in order to get accurate solutions [4]. Compatibility at nodes does not always ensure compatibility across the element boundaries. To avoid such discontinuities, interpolation functions over the element are assumed in such a fashion that the common boundaries will deform together, such elements are called compatible elements. In static analysis of the finite element method, the state of stress within each element is determined from nodal displacement. This is accomplished using interpolation functions, strain displacement relations and constitutive properties of the material.

Finite element software, ANSYS, has been used for modeling the corbels and doing parametric study. It is commercial software with three-dimensional analysis capabilities, delivering innovative, dramatic simulation technology advances in every major physics discipline, along with improvements in computing speed and enhancements to enabling technologies such as geometry handling, meshing and post-processing. It was chosen in this study because of its popularity and capabilities in handling large range of problems. Elements, modeling and the parameters considered were described in this chapter.

As mentioned earlier the model was done using ANSYS software. It is general purpose finite element software solving a wide variety of mechanical problems. These problems include static/modeling package for numerically dynamic, structural analysis (both linear and nonlinear), heat transfer, and fluid problems, as well as acoustic and electromagnetic problems. In general, ANSYS solution process may be broken into the following three stages [20].

1. Preprocessing:

Defining the problem the major steps in preprocessing are (i) define key points/lines/volumes, (ii) define element type and material/geometric properties, and (iii)

mesh lines/areas/volumes as required. The amount of detail required will depend on the dimensionality of the analysis, i.e., 1D, 2D, axisymmetric, and 3D.

2. Solution:

The main goal of finite element analysis is to examine how a structure or component response to certain loading condition. Specifying the proper loading conditions, is therefore, a key stepping analysis. Assigning loads, constraints, and solving here, it is necessary to specify the loads (point or pressure), constraints (translational and rotational), and finally solve the resulting set of equations. In the solution phase of the analysis, the computer takes over and solves the simultaneous equations that the finite element method generates. The element solution is usually calculated at the elements integration points.

3. Post processing:

Post processing means reviewing the results of an analysis. It is probably the most important step in the analysis, because it shows how the applied loads affect the design, how good finite element mesh is, and so on. Further processing and viewing of the results in this stage one may wish to see (i) lists of nodal displacements, (ii) element forces and moments, (iii) deflection plots, and (iv) stress contour diagrams or temperature maps.

4.3 FINITE ELEMENT MODELING

Two sets of modeling have been used for these problems. The first was using the two dimensional approach (plane stress), while the second was using the three dimensional approach (solid element). Material property is assumed to be homogenous and isotropic within the material. The linear analysis method has also been used. In the first case of modeling the two dimensional approach has been adopted. In this case the corbel has been modeled using plane stress elements (PLANE 183) [20]. Two dimensional elements were in which modeling of part of the section idealizes the response of the whole structure. While in the three dimensional modeling, the whole structure was modeled. The two dimensional approach was far more time saving and interpreting the result was easy, since the number of element used is smaller compared to the three dimensional analysis.

In the second type of three dimensional modeling, the corbel was modeled using solid element (SOLID 186) [20]. This idealization gives accurate simulation for geometry and location of reinforcing bars. The 20-node quadratic brick element is adopted to represent concrete in the present study. The reinforcement representation that has been used in this study was the discrete representation. It was considered to be an axial member built into the concrete element. The reinforcing bars were assumed to be capable of transmitting axial force only.

4.3.1 Two Dimensional Plane Stress Model

In the first type of modeling the two dimensional approach has been adopted. In this case the corbel has been modeled using plane stress elements (PLANE 183). The element has 8 or 6 nodes, each having two degrees of freedom. These are translations in the nodal x and y direction. PLANE183 has quadratic displacement behavior and is well suited to modeling irregular meshes. The element may be used as a plane element (plane stress, plane strain and generalized plane strain) or as an axisymmetric element. This element has plasticity, hyperelasticity, creep, stress stiffening, large deflection, and large strain capabilities. The remaining element description is given in Appendix A.

4.3.2 Three Dimensional Solid Element

In the case of three dimensional modeling, the corbel was modeled using solid element (SOLID 186). This element has 20 node and 3 DOFs at each node. It has three translational DOFs, i.e. translation in the x, y and z direction. It has 3D 20 nodes structural solid element that exhibits quadratic displacement behavior. The element has plasticity, hyperelasticity, stress stiffening, creep, large deflection, and large strain capabilities. It also has mixed formulation capability for simulating deformations of nearly incompressible elastoplastic materials, and fully incompressible hyperelastic materials. The remaining description of the element is given in Appendix B.

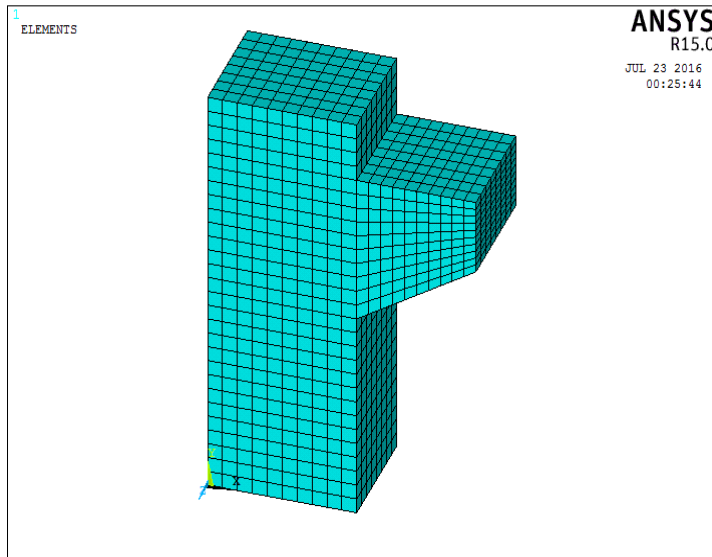

Fig. 4.2 Three dimensional model of SOLID 186 [20]

The quadratic twenty node brick elements shown in Figure (4.2) were adopted to represent concrete. This type of element is popular due to its superior performance. A major advantage of the quadratic twenty node brick element over the eight node brick element, when studying complex cases, is that less number of elements can be used, as well as it may have curved sides and therefore provides a better fit to curved sides of an actual structure. Material property is assumed to be homogenous and isotropic within the material. Linear elastic behavior prior to cracking is assumed in modeling concrete.

4.3.3 Reinforcement Idealization

Compared to concrete, steel is a much simpler material to represent. Its stress-strain behavior can be assumed to be identical in tension and compression. In reinforced concrete members, reinforcing bars are normally long and relatively slender and therefore they can be assumed to be capable of transmitting axial forces only. In the current study, the uniaxial stress-strain behavior of reinforcement was simulated by an elastic linear model.

Three techniques were existed to model steel reinforcement in finite element models for reinforced concrete [6], these were:-

- a) Discrete Representation
- b) Embedded Representation
- c) Smeared (Distributed) Representation

In the present study, the steel reinforcements were represented by LINK180 [20]. It is a 3D spar that is useful in a variety of engineering applications. The element can be used to model trusses, sagging cables, links, springs, and so on. The element is a uniaxial tension compression element with three degrees of freedom at each node: translations in the nodal x, y, and z directions. The element has Elasticity, isotropic hardening plasticity, kinematic hardening plasticity, creep, large deflection, and large strain capabilities. The remaining description of the element is given in Appendix C.

LINK 180 represented a steel reinforcement as discrete representation and included within the properties of 20 node solid elements. Perfect bond was assumed to exist between the concrete and the reinforcing bars. To provide the perfect bond, the link element for the steel reinforcing bar was connected between nodes of each adjacent concrete solid element, so the two materials share the same nodes.

4.4 MESHING

After creating of volumes, a finite element analysis requires meshing of the model. In other words, the model is divided into a number of small elements, and after loading, stresses and strains are calculated at integration points of these small elements. To obtain good results, for SOLID186 element the mesh was set up such that square or rectangular elements were created. The volume sweep command was used to mesh the solid. The necessary element divisions are noted. The meshing of the reinforcement is a special case compared to the volumes. The reinforcement model was meshed using line elements so that the nodes of the line elements come exactly over the node of the solid elements which are later merged so that both rebar elements and the concrete elements share the same nodes.

There are several ways to establish and determine a suitable mesh. How the mesh is established is mainly depending on what kind of results that are expected. Basically, to obtain more precise and accurate results, the elements size should be small and the element type should contain a large number of nodes. It is also preferable that the approximation technique should be of high order. The negative aspect of this is that the simulation can be time consuming and also the mesh can become too complex to work with [4]. A convergence of results is obtained when an adequate number of elements are used in a model. This is practically achieved when an increase in the mesh density has a

negligible effect on the results. By changing the size of the elements used in the model, the optimal mesh size was achieved. It was deemed most appropriate to use the 10 mm element size due to its converged value and trial duration.

4.5 PARAMETRIC STUDY

Parametric studies can be done by simply varying one input parameter and all other input parameters are set to constant values. Through parametric studies, it could verify the performance of model in simulating the physical behavior of reinforced concrete corbels, due to the variation in a certain parameter values. Having modeled the problem of corbel analysis, the following parameters were used to study the behavior.

1. *Effect of change in geometry.* Corbels having different outside edge depth, width and thickness were considered for the stress analysis. The range of depth at outside edge was 0.1 - 0.3 m, the range of width and thickness were 0.35 - 0.5 m. And different shear span to depth ratio (a/d) were considered. The range of shear span to depth ratio was 0.33 to 0.77.
2. *Effect of change in concrete strength.* Concrete strength varies from C-25 to C-60 were used to conduct a parametric study.
3. *Effect of change in reinforcement ratio.* The range of reinforcement ratio, ρ , was 0.0 to 0.55.
4. *Effect of change in loading condition.* Three different loading conditions were considered. These were point load, line load and distributed load conditions.
5. *Effect of change in type of modeling.* Full three dimensional solid models and two dimensional plane stress elements in which modeling of part of the section idealizes the response of the whole structure were considered with respect to variation in outside edge depth.
6. *Effect of change in analyzing method.* In order to compare the result of finite element analysis with the analytical method which stated in the code provision, the corbel is reanalyzed using STM with variable shear span to depth ratio (a/d).

Table 4.2 Range of input parameters in the model

	Ranges	
	Minimum	Maximum
Shear span to effective depth ratio ,a/d	0.33	0.77
Corbel outside edge depth ,d1 (m)	0.1	0.3
Corbel width ,b (m)	0.35	0.5
Corbel thickness ,t (m)	0.35	0.5
Concrete strength (MPa)	25	60
Reinforcement ratio, ρ (%)	0.0	0.55
Loading condition	Concentrated, line & uniformly distributed	
Modeling type	Two dimensional & three dimensional	

4.6 SCOPE AND LIMITATIONS OF THE MODEL

This thesis work should concentrate on the analysis of reinforced concrete corbel. The analyses were to be carried out in the finite element program ANSYS, with its implemented features, such as the material models for concrete and steel. The purpose of this study was to acquire a better understanding of the behavior and response of the reinforced concrete corbel under different parameters. This significant perception should lead to in preparing suitable practical guidelines for design and simple analysis. To model such a discontinue region as corbel in an exact way is not possible. So simplifications are needed. Simplifications will make it easier to model, but it must be considered that it will also affect the results from the simulations. The most important limitation is that the concrete is modeled as a linear elastic material, which means that redistribution of stress due to cracks in the concrete is not considered in the model. The gross section is resisting the applied loads at all stress levels, and that the stress-strain relationship is perfectly linear, even if the compressive strain in the concrete exceeds 0.003 or if the tensile stress at the location of the reinforcing bars exceeds the yield stress of the steel. The other important assumption in finite element analysis is that the material is isotropic and homogeneous. To the contrary, reinforced concrete is a highly composite material.

4.7 STRUT-AND-TIE MODEL EXAMPLE

Model description

A single corbel projected 400 mm from a 500×400 mm column is analyzed using STM according to Euro code 2. The corbel is given to resist a factored load 400 kN, acting at 150 mm from the face of the column. Assumption-Plate size 200×150×10 mm and material property is C-30 and Fe400

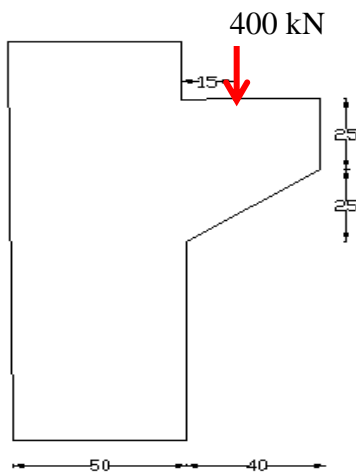

*All dimensions are in cm

Fig. 4.3 Corbel with preliminary dimension

Procedure

1. Determine the material data

The design strength concrete is,

$$f_{cd} = 0.85 f_{ck} / \gamma_c, \quad f_{ck} = 24 \text{ MPa}$$

$$f_{cd} = 0.85 \times 24 / 1.5 = 13.6 \text{ MPa}$$

The design strength steel is,

$$f_{sd} = f_{yk} / \gamma_s$$

$$f_{sd} = 400 / 1.15 = 347.8 \text{ MPa}$$

2. Check section strength below the plate with the assumed section

Node A located at 150 mm from the face of the column

Distance A to B = 150 mm + 500 mm – 50 mm = 600 mm

Node C located at $a/2$ from the right side of the column.

where, a is a depth stress block resisting the force in the strut C-E

The node at C three compression struts and one tension tie connected. The stress limit for CCT node is $\sigma_{Rd2,max} = k2v fcd = 12.3 MPa$

$$a = \frac{F_{C-E}}{12.3 \times b} = \frac{F_{C-E} \times 1000}{12.3 \times 400} = 0.203 F_{C-E} \text{ mm}$$

Summing moment about D gives,

$$\sum M_D = 400 \times 600 - F_{C-E} \times (450 - a/2)$$

$$a = 0.203 F_{C-E} \text{ mm}$$

$$0 = 240000 - 450 F_{C-E} + 0.1015 F_{C-E}^2$$

$$F_{C-E} = \frac{450 \pm \sqrt{450^2 - 4 \times 0.1015 \times 240000}}{2 \times 0.1015}$$

$$F_{C-E} = 3813 \text{ kN or } 620 \text{ kN}$$

Thus, $F_{C-E} = 620 \text{ kN}$ and $a = 0.203 \times 620 = 125.9 \text{ mm}$

Node C located at $a/2 = \frac{125.9}{2} = 62.9 \text{ mm}$ from edge of the column adjacent to C and length of C-D is $450 - 62.9 = 387 \text{ mm}$

5. Solve forces in the strut and ties

Node A:

Force acting on node A

Strut A-C has a horizontal projection of $600 \text{ mm} - 387 \text{ mm} = 213 \text{ mm}$

Vertical force of 400 kN, a horizontal force of $\frac{213 \text{ mm}}{450 \text{ mm}} \times 400 \text{ kN} = 189 \text{ kN}$

Axial force of A-C = 442 kN compression

Angle between A-C and A-B is $\tan^{-1}\left(\frac{450}{213}\right) = 64.67^\circ$

Tie A-B = 189 kN tension

Node B:

Force acting on node B

Strut B-C has a horizontal projection of 387 mm

Summing the horizontal force gives the horizontal component of the force in B-C as 189 kN

Vertical force in B-C is $\frac{450 \text{ mm}}{387 \text{ mm}} \times 189 \text{ kN} = 220 \text{ kN}$

Axial force of B-C = 290 kN compression

Angle between B-C and B-D is $\tan^{-1}\left(\frac{387}{450}\right) = 40.69^\circ$

Tie B-D = 220 kN tension

Node C:

Force acting on node

Sum of vertical force at node C = $-400 - 220 + 620 = 0$ ok!

Summing the horizontal force gives $189 - 189 = 0$

Angle between strut A-C and tie C-D is $180^\circ - 64.67^\circ = 115.33^\circ$

Angle between strut B-C and tie C-D is $90^\circ - 40.69^\circ = 49.31^\circ$

7. Compute the required width of strut and tie

i. Calculate width of tie

Assumed $\Phi = 20 \text{ mm}$ and length of bearing, $l_b = 200 \text{ mm}$

$W_t = \Phi + 2 \times \text{cover} = 20 + 2 \times 25 = 70 \text{ mm}$

ii. Calculate width of strut

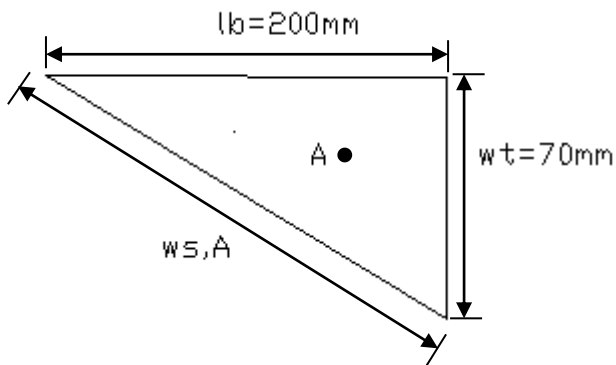

$$W_{s,A} = W_t \cos \theta + l_b \sin \theta = 70 \cos 64.67^\circ + 200 \sin 64.67^\circ = 211 \text{ mm}$$

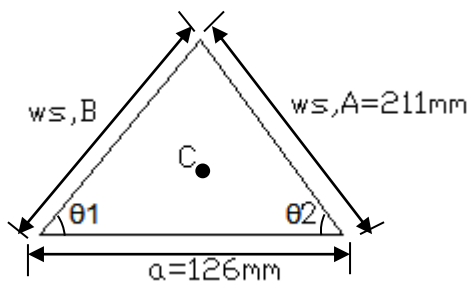

where, $\theta_1 = 64.67^\circ$ and $\theta_2 = 49.31^\circ$

$$\text{From sine law, } \frac{\sin 49.31^\circ}{w_{s,B}} = \frac{\sin 64.67^\circ}{211 \text{ mm}}$$

$$w_{s,B} = \sin 49.31^\circ \times 211 \text{ mm} / \sin 64.67^\circ = 177 \text{ mm}$$

8. Calculate the required strut stress

Knowing the strut force and the corresponding geometry, the strut stress can be found.

$$\sigma_{AC} = \frac{F_{AC}}{W_s \times b} = \frac{442 \times 1000 \text{ N}}{211 \times 400 \text{ mm}^2} = 5.24 \text{ MPa} < f_{cd} = 13.6 \text{ MPa}$$

$$\sigma_{BC} = \frac{F_{BC}}{w_s \times b} = \frac{290 \times 1000 \text{ N}}{177 \times 400 \text{ mm}^2} = 4.096 \text{ MPa} < f_{cd} = 13.6 \text{ MPa}$$

$$\sigma_{CE} = \frac{F_{CE}}{w_s \times b} = \frac{620 \times 1000 \text{ N}}{126 \times 400 \text{ mm}^2} = 12.916 \text{ MPa} < f_{cd} = 13.6 \text{ MPa}$$

Table 4.3 Summary of results of analyzing corbel by strut and tie model

a/d	Compressive principal stress (Pa)
0.33	1.29E+07
0.44	1.31E+07
0.55	1.32E+07
0.66	1.33E+07
0.77	1.35E+07

5. ANALYSES OF RESULTS

5.1 GENERAL

Modeling of the corbel was undertaken as illustrated in chapter four. After preparing the model that depicts the corbel property, meshing of the elements was undertaken and static analysis was conducted. The material properties used for the model were described in chapter four.

This chapter presents the results obtained from the parametric study. The main categories taken into consideration were effect of change in geometry, concrete strength, reinforcement ratio, loading condition and modeling type. By examining the effects caused by adjusting the different parameters of the model, a better understanding of how each component of the model contributes to the system could be gained. The geometry components to be examined, on an individual case by case basis, were the corbel thickness, width, outside edge depth and the shear span to effective depth ratio. Distributed, line and concentrated loading condition were examined under different outside edge depth and also considered in two dimensional as well as three dimensional modeling of reinforced concrete corbels. Change in concrete strength and reinforcement ratio also considered in this study. In order to verify the result of finite element model, the corbels were reanalyzed by a strut and tie model.

ANSYS general purpose finite element software has been used for parametric study and the software provides a feature that evaluates the mesh quality. After several tryouts the mesh passed all the quality tests and the analysis is done, ANSYS checks whether any badly shaped elements exist. There were no such warning messages in the analysis progress window or in the standard output file, so it's possible to inspect and accept the analysis results. The results obtained were presented in the next sections.

5.2 EFFECT OF CHANGE IN GEOMETRY

In this part of analysis, the paper concentrates on how change in geometry affects the performance of corbels. Thickness, width, outside edge depth and the shear span to effective depth ratio were selected in order to do a parametric study. The output of this analysis is presented for each corbel for varying geometry as follows.

For all the analyses conducted in this section of parametric study, the following features were kept the same:

- Loading ($V= 400$ kN)
- Overall depth of corbel ($h = 0.5$ m)
- Effective depth of corbel ($d= 0.45$ m)
- Modeling type - three dimensional approach

Case 1. 3D model with variable outside edge depth

In this section, the effect of change in outside edge depth on the performance of reinforced concrete corbel was manifested by obtaining the variation in displacement resultant and maximum principal stress was presented.

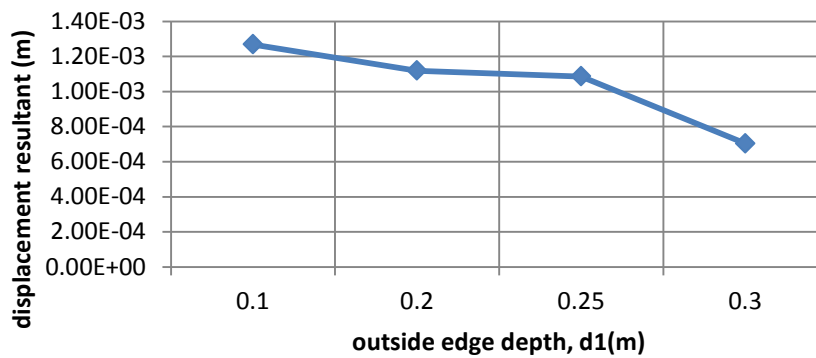

Fig. 5.1 Displacement resultant with variable outside edge depth

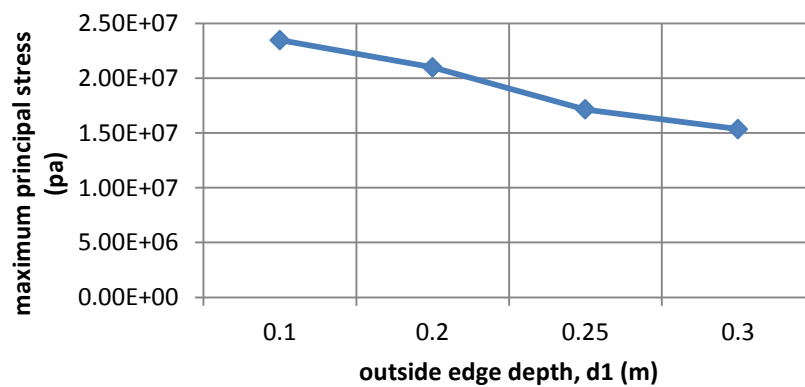

Fig. 5.2 Maximum principal stress with variable outside edge depth

The displacement resultant and the maximum principal stress with variable outside edge depth were decreased as corbels subjected to concentrated loading. That is the outside

edge depth increased from 0.1 to 0.3 m the value of the displacement resultant and the maximum principal stress were decreased by 44.5% and 34.6% respectively.

Case 2. 3D model with variable shear span to effective depth ratio

In this section, the effect of change in shear span to effective depth ratio on the performance of reinforced concrete corbel was manifested by obtaining the variation in displacement resultant and maximum principal stress was presented.

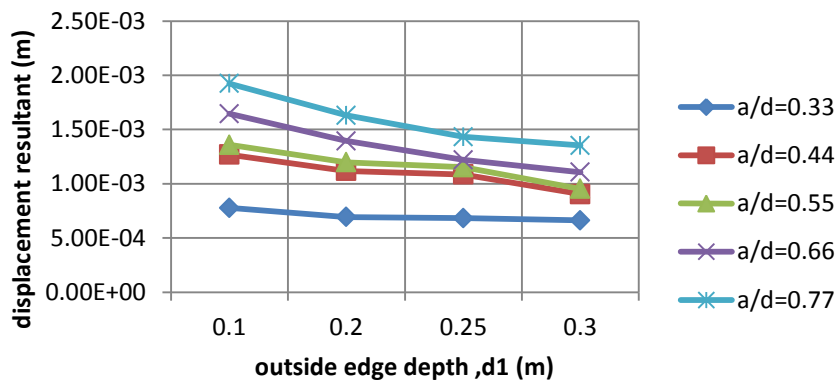

Fig. 5.3 Displacement resultant with variable shear span to effective depth ratio

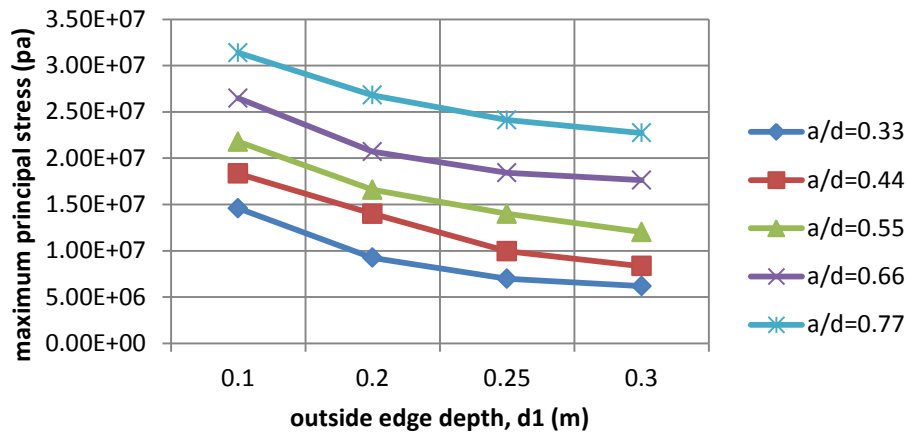

Fig. 5.4 Maximum principal stress with variable shear span to effective depth ratio

From the graphical result above, it was observed that when the shear span to effective depth ratio (a/d) increased from 0.33 to 0.77, the displacement resultant was increased by 59.6% and the maximum principal stress was increased by an amount of 53.5%. This was due to as the shear span increase, the bending action also increased and leads to increasing deflection and stress.

Case 3. 3D model with variable width

In this section, the effect of change in width on the performance of RC corbel was manifested by obtaining the variation in displacement resultant and maximum principal stress was presented.

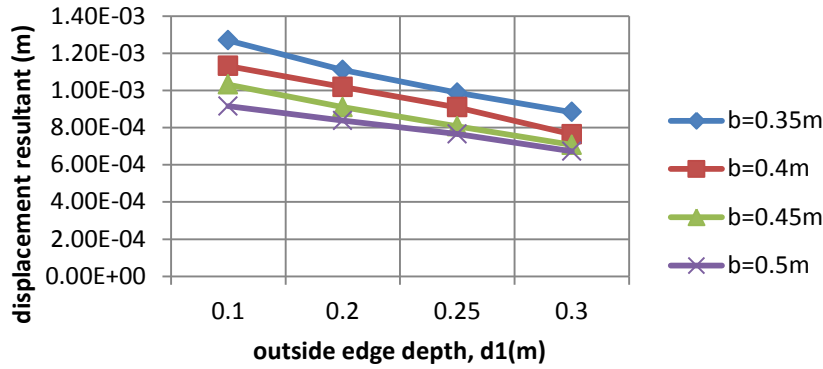

Fig. 5.5 Displacement resultant with variable width

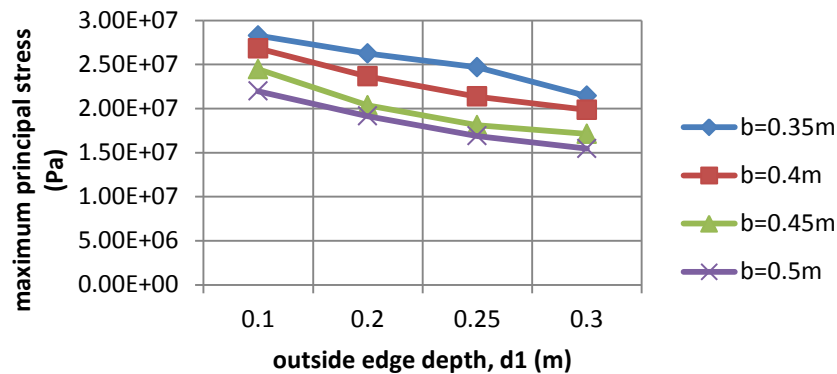

Fig. 5.6 Maximum principal stress with variable width

The displacement resultant and the maximum principal stress were decreased as the width of a corbel was increased from 0.35 to 0.5 m. The displacement resultant was decreased by 27.9% while the maximum principal stress decreased by an amount of 22.3%.

Case 4. 3D model with variable thickness

In this section, the effect of change in thickness on the performance of reinforced concrete corbel was manifested by obtaining the variation in displacement resultant and maximum principal stress was presented.

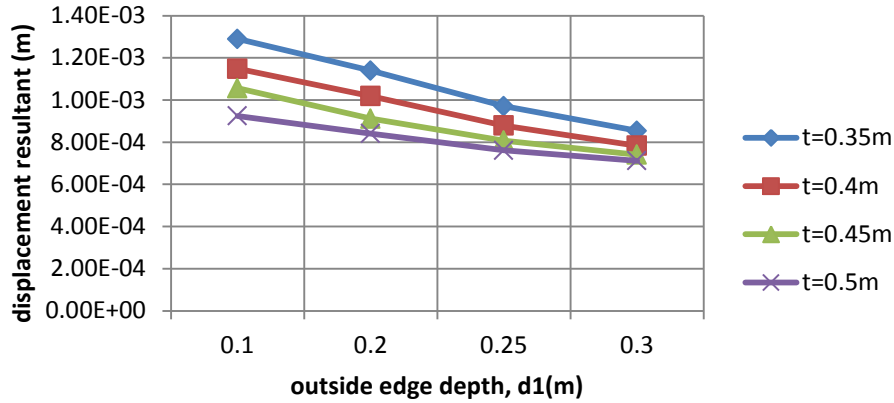

Fig. 5.7 Displacement resultant with variable thickness

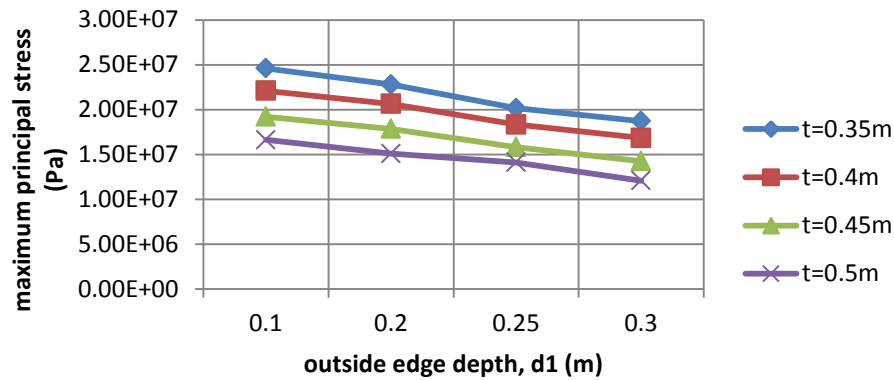

Fig. 5.8 Maximum principal stress with variable thickness

In case when the corbels were subjected to concentrated load with variable thickness, the displacement resultant and the maximum principal stress were decreased as the thickness of a corbel increased from 0.35 to 0.5 m. There were a 28.3% and 32.4% decreasing in displacement resultant and maximum principal stress values respectively.

5.3 EFFECT OF CHANGE IN CONCRETE STRENGTH

In this part of analysis, the paper concentrates on how change in concrete strength affects the performance of corbels. The output of this analysis was presented for each corbel for varying concrete strength as follows.

For all the analyses conducted in this section of parametric study, the following features were kept the same:

- Loading (V= 400 kN)
- Overall depth of corbel (h = 0.5 m)

- Width of corbel ($b = 0.4$ m)
- Thickness of corbel ($h = 0.5$ m)
- Effective depth of corbel ($d = 0.45$ m)
- Modeling type - three dimensional approach

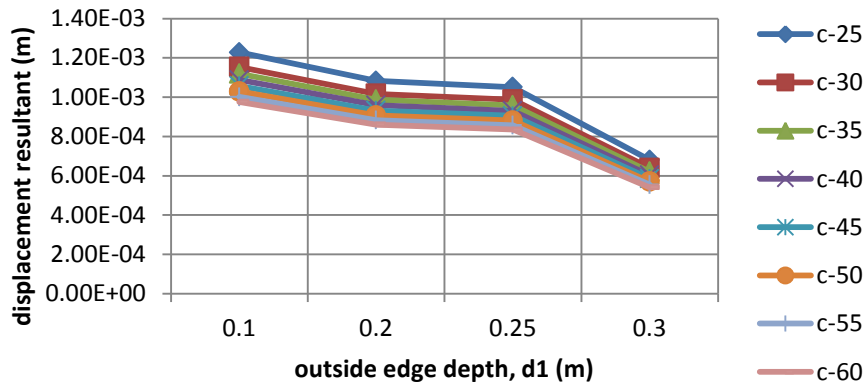

Fig. 5.9 Displacement resultant with variable concrete strength

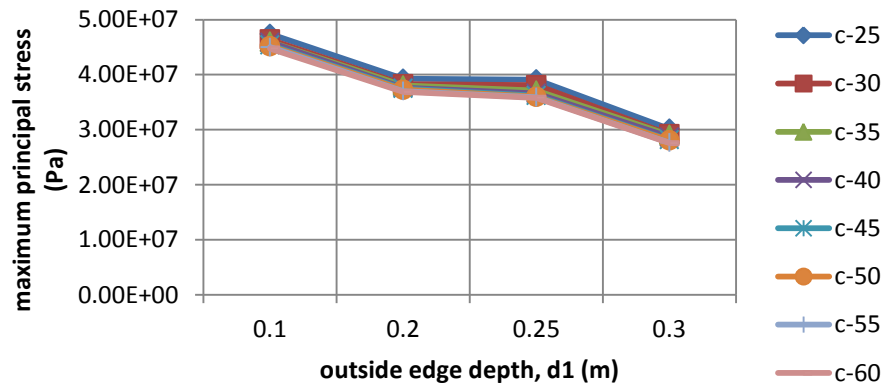

Fig. 5.10 Maximum principal stress with variable concrete strength

As concrete strength varies from C-25 to C-60, both the displacement resultant and the maximum principal stress were decreased. There were 20.5% and 5.57% decrease in displacement resultant and the maximum principal stress respectively.

5.4 EFFECT OF CHANGE IN REINFORCEMENT RATIO

In this part of analysis, the paper concentrates on how change in reinforcement ratio affects the performance of corbels. The output of this analysis was presented for each corbel for varying reinforcement ratio as follows.

For all the analyses conducted in this section of parametric study, the following features were kept the same:

- Loading (V= 400 kN)
- Overall depth of corbel (h = 0.5 m)
- Width of corbel (b= 0.4 m)
- Thickness of corbel (h = 0.5 m)
- Effective depth of corbel (d= 0.45 m)
- Modeling type - three dimensional approach

Table 5.1 Summary of results of analyzing corbel with different reinforcement ratio

Reinforcement ratio, ρ (%)	Displacement resultant (m)	Maximum principal stress (Pa)
0.0	1.12E-03	3.93E+07
0.15	1.14E-03	3.96E+07
0.2	1.17E-03	3.97E+07
0.25	1.18E-03	3.98E+07
0.3	1.18E-03	3.98E+07
0.35	1.19E-03	3.98E+07
0.4	1.19E-03	3.98E+07
0.45	1.19E-03	3.98E+07
0.5	1.19E-03	3.98E+07
0.55	1.19E-03	3.98E+07

From the tabulated result above, as the reinforcement ratio varies from 0.0 to 0.55 there were a little bit variation on both the displacement resultant and the maximum principal stress especially in lower value.

5.5 EFFECT OF CHANGE IN LOADING CONDITION

As loading condition is one of a key factor influencing behavior of reinforced concrete corbels, this section will concentrate on it. The loading conditions were concentrated, line load and uniformly distributed load which were applied at a three dimensional solid model. The output of this analysis is presented for each loading type for varying outside edge depth as follows. For all the analyses conducted in this section of parametric study, the following features are kept the same:

- Width of corbel (b= 0.4m)
- Thickness of corbel (t=0.4m)

- Overall depth of corbel ($h = 0.5$ m)
- Effective depth of corbel ($d = 0.45$ m)
- Modeling type - three dimensional approach

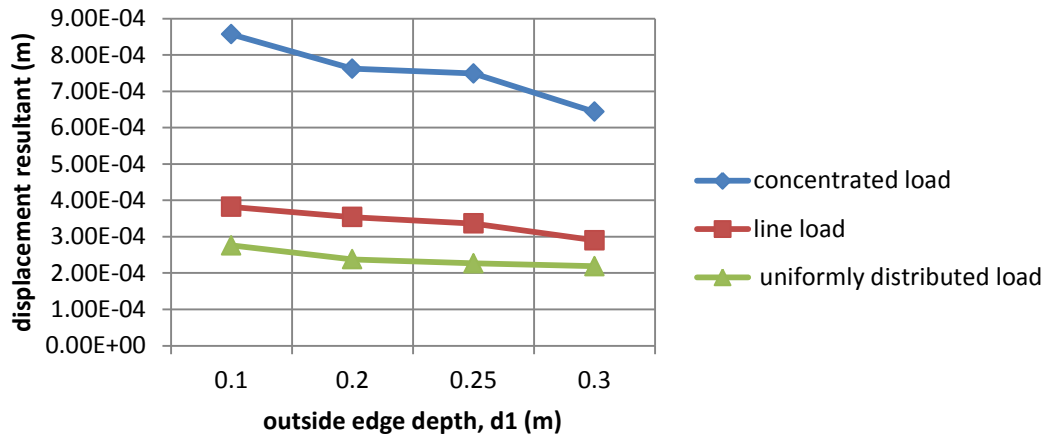

Fig. 5.11 Displacement resultant with variable loading condition

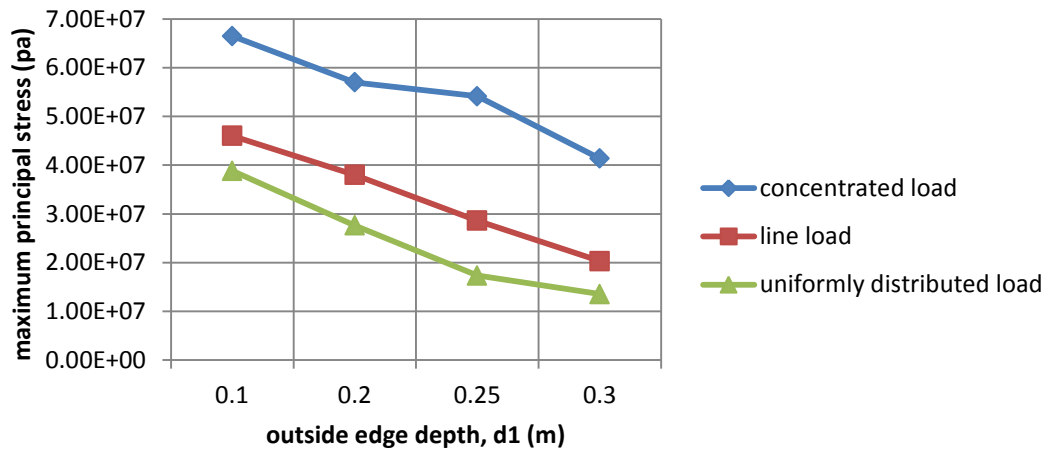

Fig. 5.12 Maximum principal stress with variable loading condition

In case when the corbels subjected to different loading conditions were presented in the above graph. Effect of concentrated load, line load and uniformly distributed load with variable outside edge depth were evaluated. Both the displacement resultant and the maximum principal stress were decreased as the loading varies from concentrated to uniformly distributed load. As the loading in the corbel varies from concentrated to line loading, the displacement resultant and the maximum principal stress were decreased by

55.4% and 30.8% respectively. There was a 67.8% and 41.6% decrease in the displacement resultant and the maximum principal stress for corbel subjected from concentrated to uniformly distributed load. The percentage decrease in the model was 28% and 15.6% recorded for loading varies from line to uniformly distributed load.

5.6 EFFECT OF CHANGE IN TYPE OF MODELING

In this section, the effect of change in modeling type on the performance of reinforced concrete corbels will study. One is for full three dimensional solid model while the other is two dimensional plane stress elements in which modeling of part of the section idealizes the response of the whole structure were considered with respect to variation in outside edge depth. The output from this analysis is given below.

For all the analyses conducted in this section of parametric study, the following quantities or features are kept the same:

- Loading ($V = 400 \text{ kN}$)
- Width of corbel ($b = 0.4 \text{ m}$)
- Overall depth of corbel ($h = 0.5 \text{ m}$)
- Effective depth of corbel ($d = 0.45 \text{ m}$)
- Shear span ($a = 0.2 \text{ m}$)

Table 5.2 Comparison of displacements and principal Stresses in 2D and 3D model

d1 (m)	Displacement Resultant (m)		Maximum variation	Maximum principal stress (Pa)		Maximum variation
	2D model	3D model		2D model	3D model	
0.1	7.19E-04	1.27E-03	43.33%	1.44E+07	2.35E+07	38.60%
0.2	6.68E-04	1.12E-03	40.30%	1.11E+07	2.10E+07	47.10%
0.25	6.30E-04	1.02E-03	38.00%	9.62E+06	1.71E+07	43.90%
0.3	6.09E-04	9.03E-04	32.60%	8.01E+06	1.53E+07	47.80%

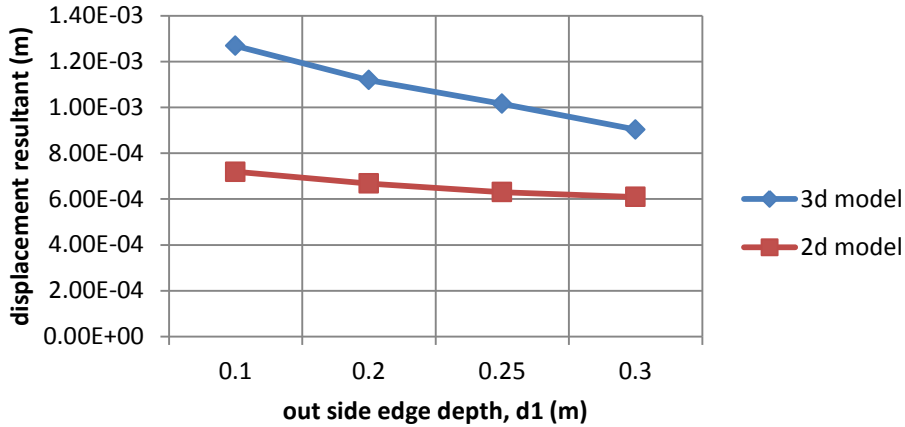

Fig. 5.13 Displacement resultant with different modeling type

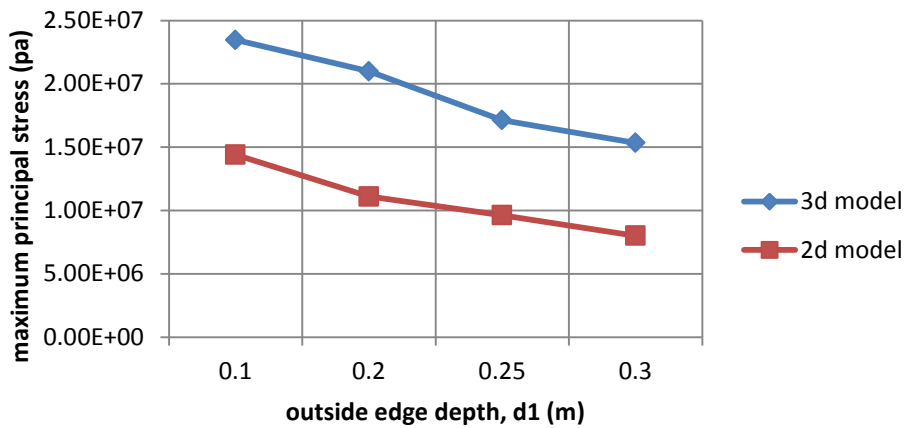

Fig. 5.14 Maximum principal stress with different modeling type

Corbels have been modeled as a solid three dimensional as well as two dimensional plane stress element. Two dimensional elements were in which modeling of part of the section idealizes the response of the whole structure, while in the three dimensional modeling, the whole structure was modeled. The two dimensional approach was far more time saving and interpreting the result was easy, since the number of element used is smaller compared to the three dimensional analysis. The parametric study shows that both the displacement resultant and the maximum principal stress were high in case of corbels modeled as solid model as compared to plane stress model. There were a 43.33% and 47.80% maximum variation in displacement resultant and the maximum principal stress respectively.

5.7 COMPARISON OF STM AND FEM

In this part of analysis, the paper concentrates on how varies the numerical analysis that is the finite element method from the strut and tie model in the behavior of corbels with respect to different shear span to effective depth ratio. For all the analyses conducted in this section of parametric study, the following quantities or features are kept the same:

- Loading ($V= 400 \text{ kN}$)
- Width of corbel ($b= 0.4\text{m}$)
- Overall depth of corbel ($h = 0.5 \text{ m}$)
- Effective depth of corbel ($d= 0.45 \text{ m}$)
- Outside edge depth ($d_1=0.25\text{m}$)

Table 5.3 Comparison of maximum compression principal stresses in FEM and STM

a/d	Maximum compressive principal stress (pa)		Maximum variation
	FEM	STM	
0.33	1.35E+07	1.29E+07	4.5%
0.44	1.40E+07	1.31E+07	6.4%
0.55	1.49E+07	1.32E+07	11.4%
0.66	1.54E+07	1.33E+07	13.6%
0.77	1.59E+07	1.35E+07	15.09%

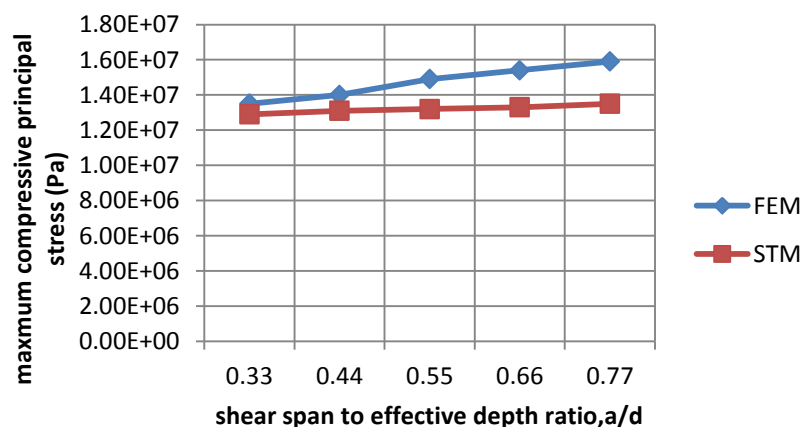

Fig. 5.15 Maximum principal stress with different analyzing method

The result of a finite element method of analyzing corbel was compared with the analytical method that is a strut and tie model. The maximum compressive principal stress with respect to a shear span to effective depth ratio for the finite element model

and strut and tie model were presented in graphically. The result shows that there was a maximum variation of 15.09% decrease in maximum compressive principal stress in STM as compared to FEM.

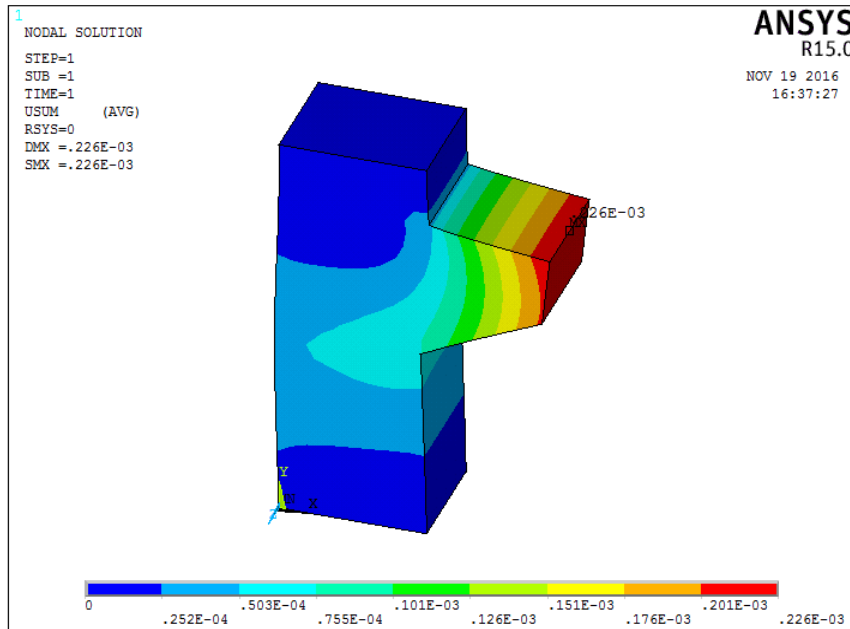

Fig. 5.16 Contour plot of displacement resultant for 3D model

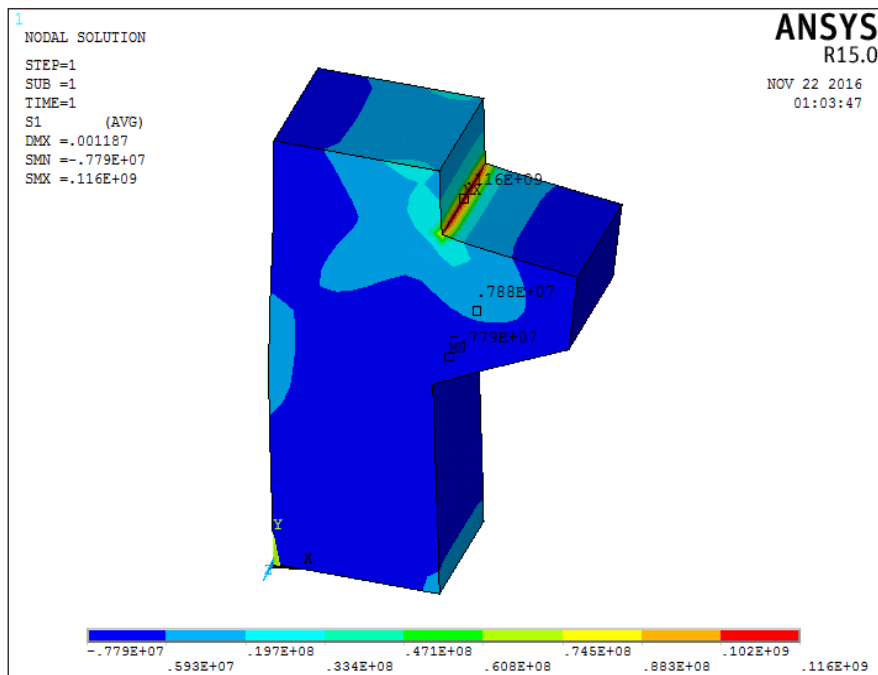

Fig. 5.17 Contour plot of maximum principal stress for 3D model

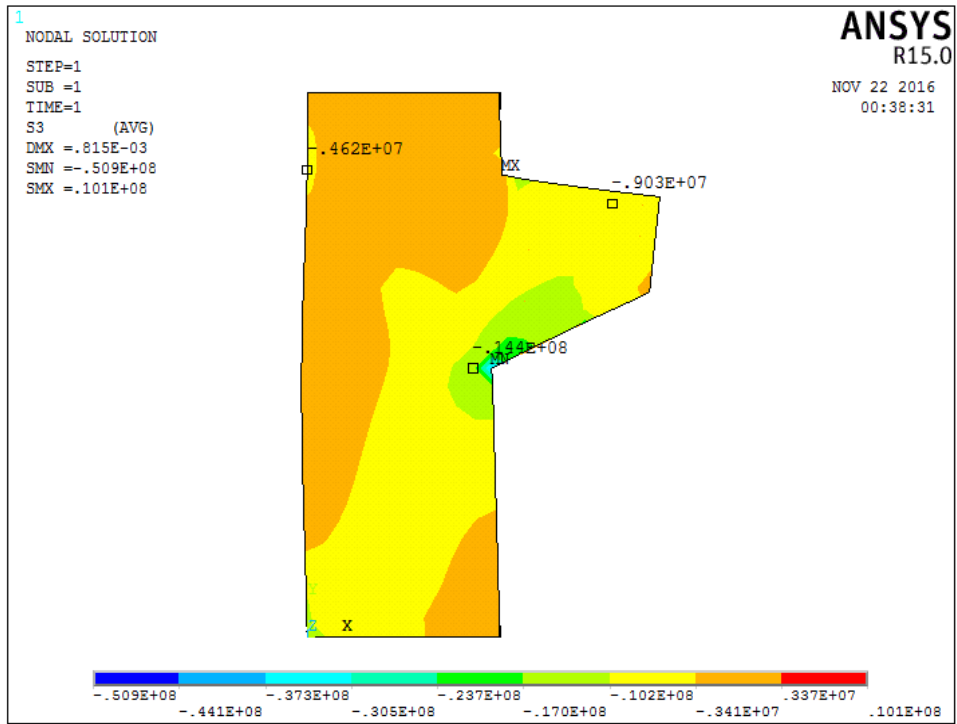

Fig. 5.18 Contour plot of nodal stress for 2D model

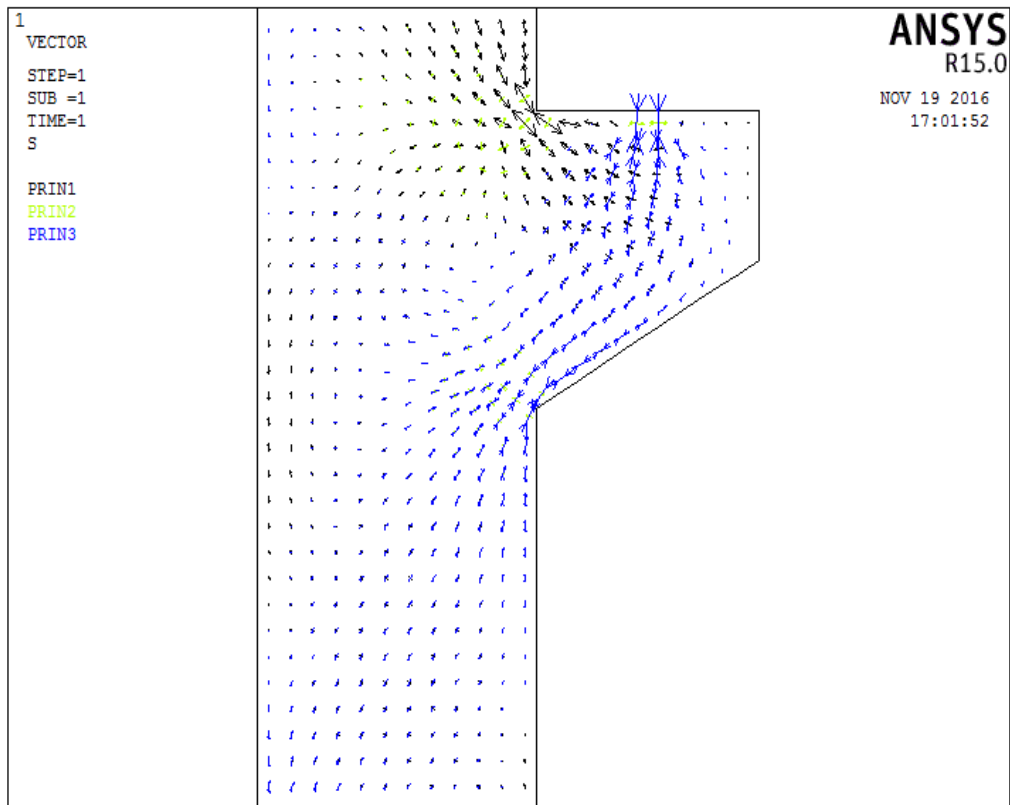

Fig. 5.19 Vector plot of principal stress for 2D model

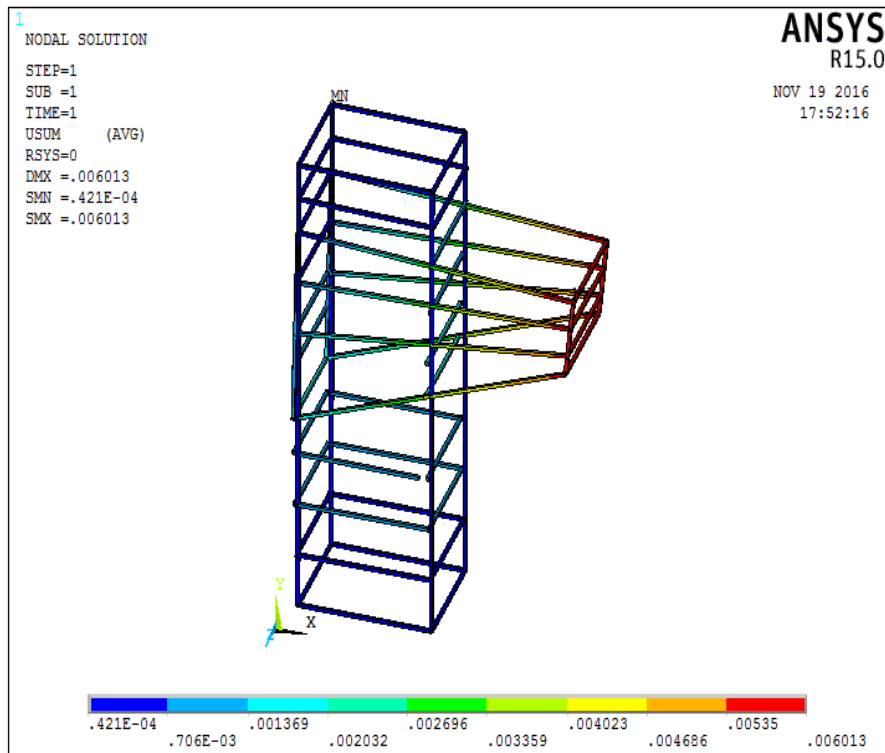

Fig. 5.20 Contour plot of displacement resultant for LINK180 element

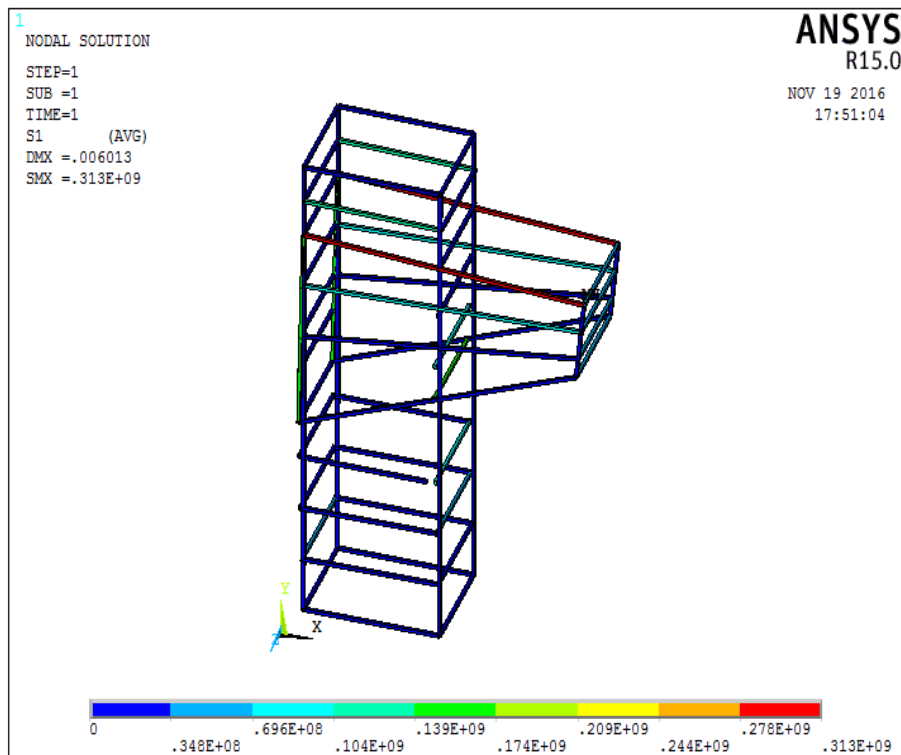

Fig. 5.21 Contour plot of principal stress for LINK180 element

5.8 SUMMARY OF THE ANALYSIS RESULTS

Generalizing the analysis result, the FEM for the different loading condition, geometry, concrete strength, reinforcement ratio and modeling type, the following observations has been made.

Throughout the parametric study involving the geometric makeup of the finite element analysis model one consistent conclusion can be made. As the thicknesses, width and outside edge depth of corbel were increased, the deflection and the maximum principal stress decreased. This is due to the fact that as the flexural rigidity, EI , increases, decreasing the stress and deflection. And it also compromised with the code provision in limiting outside edge depth not to be less than half of the overall depth, h . It clearly shows that if the outside edge depth, d_1 less than $0.5h$ the value of principal stress was high and it may be failure occur beneath the bearing plate. When the outside edge depth equals the corbel overall depth ($d_1=h$), there was a stress free area around the outside lower corner of corbel and this area in most cases are ignored in stress analysis. The shear span-to-depth ratio, and therefore, strut inclination, plays a significant role in determining the shear strength of the corbels. As the shear span to effective depth ratio increase, the principal stress and the deflection were increased and lower the corbel strength. The maximum strength was obtained at the shear span approaches the column-corbel interface but as the shear span far away from the interface, it represents condition of pure bending. Generally, through parametric study of the effect of changing geometry of corbels, significant variation in both deflection and principal stress shows in corbels with different shear span to effective depth ratio and a little bit effect observed in width and thickness variation of a corbels.

As variation in concrete strength and reinforcement ratio on the behavior of corbels observed, there were a little bit effect on the displacement resultant and the maximum principal stress values. Especially effect of reinforcement ratio was negligible in a linear stress analysis of reinforced concrete corbels.

For corbels subjected to uniform loading exhibits increasing the strength compared with concentrated loading. Both the principal stress and deflection was decreased when the corbel was subjected to uniform loading as compared to corbel subjected to concentrated loading. Similarly corbels subjected to line load exhibits increasing the strength

compared with concentrated loading. But the degree of increment was different in the two cases.

In the two dimensional approach of the finite element method, the result with different outside edge depth have been a significant deviation from the three dimensional approach. The deflection and principal stress values of two dimensional model found out to be less than of from the full three dimensional analysis. The element use in two dimensional was less and as the number of finite element increase the result was approached to the exact solution. So that the three dimensional approach was useful in predicting the corbel behavior approach to the exact solution. But a major drawback of these three dimensional approach were as the number of element increase, the size of each element becomes small and it is difficult to identify the stress in each element and takes a long time and internal memory in running the analysis.

Finally in order to compare a result of finite element approach with the analytical method, corbels were reanalyzed by a strut and tie model with respect to different shear span to effective depth ratio. Comparing the result of finite element method with the strut and tie model, the principal stress obtained using the STM are generally smaller. These variation may come from as a strut and tie model is based on the lower bound plasticity theory while the assumption made in this thesis for finite element model was linear, elastic, isotropic material property. The capacity of the struts was checked to ensure that their compressive stress does not exceed the effective stress capacity. The maximum compressive principal stress value obtained from the analysis doesn't reach the effective compressive strength of concrete.

6. CONCLUSIONS AND RECOMMENDATIONS

6.1 CONCLUSIONS

This study was conducted to study structural behavior of reinforced concrete corbels with a number of parameters. In this paper, numerical approach has been used for predicting the behavior of reinforced concrete corbels. A parametric study was made by varying the geometry, concrete strength, reinforcement ratio, loading condition, modeling type and method of analyzing to investigate their effect on the deflection and maximum principal stress of corbels. The general purpose finite element software ANSYS was used to do a parametric study. The contribution of this thesis work can be summarized as follows:

1. As the outside edge depth, width and thickness increased, the displacement resultant and the principal stress were decreased in corbels of three dimensional model subjected to concentrated loading.
2. Both the displacement resultant and the principal stress were increased, as the shear span to effective depth ratio increase.
3. Corbels subjected to uniform and line loading gives lower displacement and principal stress than of subjected to concentrated load.
4. The value of displacement resultant and principal stress in three dimensional model was higher than of two dimensional model.
5. The concrete strength and reinforcement ratio were little effect on the uncracked section of corbel.
6. To verify the result of finite element model with different shear span to effective depth ratio, corbels were reanalyzed by strut and tie model. The compressive principal stress using a strut and tie model gives lower result than of a finite element method.

EBCS 2 provides very little guidance in using strut and ties models, which covers mainly the effective concrete strength provisions for the various strut and tie elements. The code lacks extensive coverage of the STM design procedures for different cases and it is difficult to do a comprehensive parametric study. So that the finite element method gives through insight for different parameters which affect the behavior of reinforced concrete corbels.

From the study under taken, the above resulted conclusions are indications of structural behavior of corbels with different parameter. Therefore, for the increasing demand on use concrete corbel like in industry, the observations and conclusions made in this thesis could help to bring clear understanding of the stress distribution of corbels and lead to in preparing suitable practical guidelines for design and simple analysis. And also will increase the possibility of using it in confidence.

6.2 RECOMMENDATIONS

Generally, the following areas are worthy for further research in the light of this thesis.

1. The most important limitation made is the assumption of linear concrete behavior, which in practice means that an assumption of no cracks in the concrete is made. To be able to perform a complete analysis of the system must the non-linearity of concrete be built-in to the model.
2. Provide clarification on STM in EBCS 2 since it provides very little guidance in using strut and ties models.
3. The present study was on a numerical and analytical method of analyzing corbel. Doing experimental investigation and comparing the result with finite element method can be taken up as an area of further work.

REFERENCE

1. Tjen, N.T., and Daniel, A.K., "Computer-Based Tools for Design by Strut-and-Tie Method: Advances and Challenges" *ACI Structural Journal*, V.99, No.5, September-October 2002, pp.586-594.
2. ACI 318-02, "Building Code Requirements for Structural Concrete (ACI 318-02) and Commentary (ACI 318R-02)", American Concrete Institute, Michigan, USA, 2002.
3. Hwang, S.J., Lu, W.Y., and Lee, H.J., "Shear Strength Prediction for Reinforced Concrete Corbels", *ACI Structural Journal*, Vol.97, No.4, July-August, 2000, pp. 543–552.
4. Bhavikatti, S.S., "Finite Element Analysis", New Age International Limited Publishers, New Delhi, 2005.
5. Hsu, T.C., and Mo, Y.L., "Unified Theory of Concrete Structures", University of Houston, USA, A John Willey and Sons Limited Publishers, 2010.
6. Moaveni, S., "Finite Element Analysis Theory and Application with ANSYS", Minnesta State University, Mankato, Prentice Hall, Upper Saddle River, New Jersey Publisher, 1999.
7. Powell, R.E., and Foster, S.J., "Experimental Investigation On Rectangular Corbels Cast In High Strength Concrete", M.Eng thesis, the University of New South Wales, Sydney, Australia, August 1994.
8. Akthem, A.A., "A Nonlinear Finite Element Study of Reinforced Concrete Beams", Ph.D. thesis, University of Glasgow, August 1983.
9. Kriz, L.B., and Raths, C.H., "Connections in Precast Concrete Structures-Strength of Corbels", *PCI Journal*, V.10, No.1, N.4, February 1965, pp.16–61.
10. Singh, B., Mohammad, Y., Kaushik S., "Design of a Double Corbel using the Strut-and Tie Method", *Asian Journal, Civil Engineering. Building Housing*, 2005 pp.21–33.
11. Prasad, H.N., Channakeshava, B.K., Prasad, K.T., Iyengar, S.R., "Nonlinear Finite Element Analysis of Reinforced Concrete Corbel" *Composite. Structure*, 1993, pp.343–354.
12. Somerville, G., "The Behavior and Design of Reinforced Concrete Corbels", *Cement. Concrete Association, Technical Report 42.472*, London, August 1972.
13. Yong, Y.K., McCloskey, D.H., Nawy, E.G., "Reinforced Corbels of High-Strength Concrete", *American Concrete Institute, Detroit*, 1985, pp.197–212.
14. Hagberg, T., "Design of Concrete Brackets: On the Application of the Truss Analogy", *ACI Journal*, V.80, No.1, January-February 1983, pp.3–12.

15. Rezaei, M.N, Osman, S.A., Shanmugam, N.E., “Effect of Column-Load on Single and Double Corbels”, Proceeding of the first Iranian Students Scientific Conference in Malaysia, April 2011.
16. Mattock, A.H., “Design Proposals For Reinforced Concrete Corbels”, PCI Journal, Prestressed Concrete Institute, V.21, No.3, May–June 1976, pp.18–42
17. Franz, G., and Niedenhoff, H., “Reinforcement for Brackets and Short Beams” , V.48, No.5, 1963, pp.112–120
18. Yousif, A., “Prediction of Ultimate Load Capacity of High-Strength Reinforced Concrete Corbels”, Al-Rafidain Engineering, 2009, pp.12–27.
19. Hermansen, B., Cowan, J., “Modified Shear-Friction Theory for Brackets Design”, ACI Journal, 1974, pp.55–60.
20. “ANSYS Theory Reference: Release 15.0” , SAS IP ,Inc

This page intentionally left blank

APPENDIX A

PLANE 183

A1. Element Description

PLANE183 is a higher order 2-D, 8-node or 6-node element. PLANE183 has quadratic displacement behavior and is well suited to modeling irregular meshes (such as those produced by various CAD/CAM systems).

This element is defined by 8 nodes or 6 nodes having two degrees of freedom at each node: translations in the nodal x and y directions. The element may be used as a plane element (plane stress, plane strain and generalized plane strain) or as an axisymmetric element. This element has plasticity, hyperelasticity, creep, stress stiffening, large deflection, and large strain capabilities. It also has mixed formulation capability for simulating deformations of nearly incompressible elastoplastic materials, and fully incompressible hyperelastic materials. Initial state is supported.

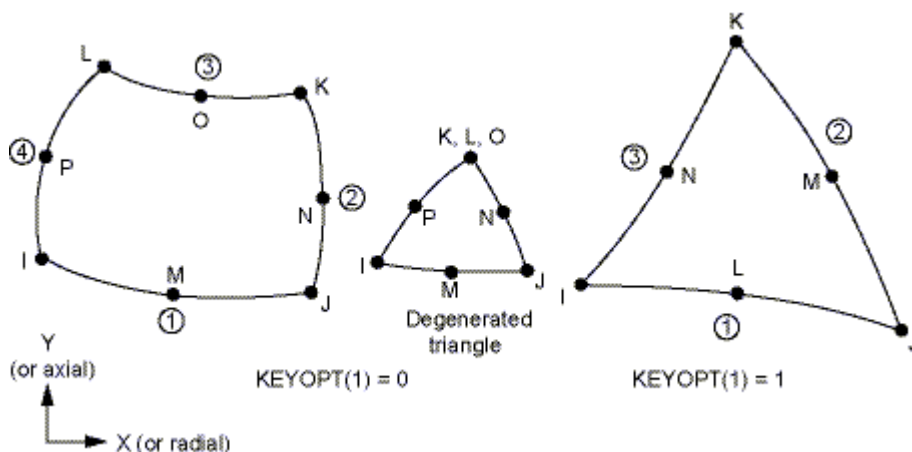

Fig.A1 PLANE183 Geometry

A2. PLANE183 Input Data

The geometry, node locations, and the coordinate system for this element are shown in Fig. A1.

Although a degenerated triangular-shaped element may be formed by defining the same node number for nodes K, L and O when KEYOPT (1) = 1, it is better to use KEYOPT (1) = 1 for triangular shaped elements.

In addition to the nodes, the element input data includes a thickness (TK) (for the plane stress option only) and the orthotropic material properties. Orthotropic material directions correspond to the element coordinate directions.

Pressures may be input as surface loads on the element faces as shown by the circled numbers in Fig.A1. Positive pressures act into the element. Temperatures may be input as element body loads at the nodes. The node I temperature T(I) defaults to TUNIF. If all other temperatures are unspecified, they default to T (I). If all corner node temperatures are specified, each mid side node temperature defaults to the average temperature of its adjacent corner nodes. For any other input temperature pattern, unspecified temperatures default to TUNIF.

The nodal forces, if any, should be input per unit of depth for a plane analysis (except for KEYOPT (3) = 3 or KEYOPT (3) = 5) and on a full 360° basis for an axisymmetric analysis.

For the case of hyperelastic materials, the output of stress and strain is always with respect to the global Cartesian coordinate system rather than following the material/element coordinate system.

KEYOPT (3) = 5 is used to enable generalized plane strain.

KEYOPT (6) = 1 sets the element for using mixed formulation.

The effects of pressure load stiffness are automatically included for this element.

A3. PLANE183 Input Summary

Nodes

I, J, K, L, M, N, O, P when KEYOPT (1) = 0

I, J, K, L, M, N when KEYOPT (1) = 1)

Degrees of Freedom

UX, UY

Real Constants

None, if KEYOPT (3) = 0, 1, or 2

THK - Thickness if KEYOPT (3) = 3

Material Properties

EX, EY, EZ, PRXY, PRYZ, PRXZ (or NUXY, NUYZ, NUXZ),

ALPX, ALPY, ALPZ (or CTEX, CTEY, CTEZ *or* THSX, THSY, THSZ),

DENS, GXY, GYZ, GXZ, ALPD, BETD

Surface Loads

Pressures --

face 1 (J-I), face 2 (K-J), face 3 (L-K), face 4 (I-L) when KEYOPT(1) = 0

face 1 (J-I), face 2 (K-J), face 3 (I-K) when KEYOPT(1) = 1

Body Loads

Temperatures --

T(I), T(J), T(K), T(L), T(M), T(N), T(O), T(P) when KEYOPT(1) = 0

T(I), T(J), T(K), T(L), T(M), T(N) when KEYOPT(1) = 1

Body force densities --

The element values in the global X and Y directions.

Special Features

Birth and death, element technology auto select, initial stress, large deflection, large strain, linear perturbation, material force evaluation, nonlinear stabilization, rezoning, and stress stiffening

A4. PLANE183 Output Data

The solution output associated with the element is in two forms:

- Nodal displacements included in the overall nodal solution
- Additional element output as shown in in element output definition

The element stress directions are parallel to the element coordinate system.

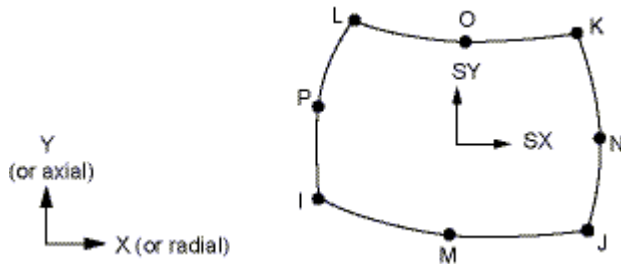

Fig. A2 PLANE183 Stress Output

A5. PLANE183 Assumptions and Restrictions

- The area of the element must be positive.
- The element must lie in a global X-Y plane as shown in Fig. A1 and the Y-axis must be the axis of symmetry for axisymmetric analyses. An axisymmetric structure should be modeled in the +X quadrants.
- A face with a removed mid side node implies that the displacement varies linearly, rather than parabolically, along that face. Use at least two elements to avoid hourglass mode for KEYOPT (1) = 0.
- A triangular element may be formed by defining duplicate K-L-O node numbers. For these degenerated elements, the triangular shape function is used and the solution is the same as for the regular triangular 6-node elements, but might be slightly less efficient for KEYOPT (1) = 0. Since these degenerated elements are less efficient, the triangle shape option (KEYOPT (1) = 1) is suggested for this case.
- When mixed formulation is used (KEYOPT (6) = 1), no mid side nodes can be missed. If you use the mixed formulation (KEYOPT (6) = 1), you must use the sparse solver (default).
- Stress stiffening is always included in geometrically nonlinear analyses.

APPENDIX B

SOLID186

B1. Element Description

SOLID186 is a higher order 3-D 20-node solid element that exhibits quadratic displacement behavior. The element is defined by 20 nodes having three degrees of freedom per node: translations in the nodal x, y, and z directions. The element supports plasticity, hyperelasticity, creep, stress stiffening, large deflection, and large strain capabilities. It also has mixed formulation capability for simulating deformations of nearly incompressible elastoplastic materials, and fully incompressible hyperelastic materials.

SOLID186 is available in two forms:

- Homogeneous Structural Solid (KEYOPT(3) = 0, the default)
- Layered Structural Solid (KEYOPT(3) = 1)

SOLID186 Homogeneous Structural Solid is well suited to modeling irregular meshes (such as those produced by various CAD/CAM systems). The element may have any spatial orientation.

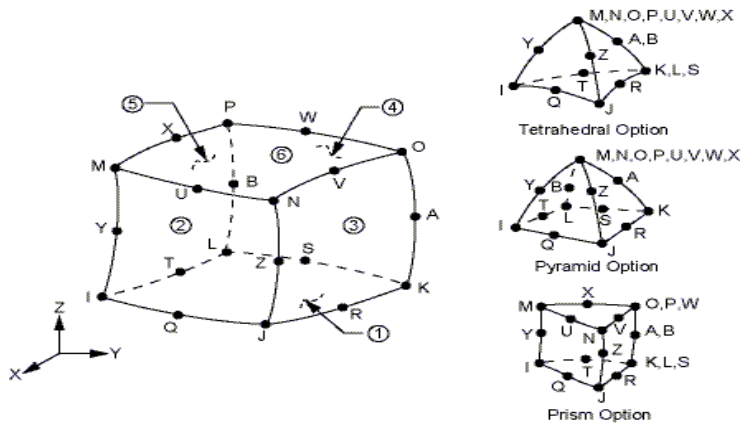

Fig.B1 SOLID186 Homogeneous Structural Solid Geometry

B2. Input Data

The geometry, node locations, and the element coordinate system for this element are shown in Fig. B1. A prism-shaped element may be formed by defining the same node numbers for nodes K, L, and S; nodes A and B; and nodes O, P, and W. A tetrahedral-shaped element and a pyramid-shaped element may also be formed as shown in Fig.B1.

In addition to the nodes, the element input data includes the anisotropic material properties. Anisotropic material directions correspond to the element coordinate directions.

Pressures may be input as surface loads on the element faces as shown by the circled numbers on Fig.B1. Positive pressures act into the element. Temperatures may be input as element body loads at the nodes. The node I temperature T(I) defaults to TUNIF. If all other temperatures are unspecified, they default to T(I). If all corner node temperatures

are specified, each mid side node temperature defaults to the average temperature of its adjacent corner nodes. For any other input temperature pattern, unspecified temperatures default to TUNIF.

B3. SOLID186 Homogeneous Structural Solid Input Summary

Nodes

I, J, K, L, M, N, O, P, Q, R, S, T, U, V, W, X, Y, Z, A, B

Degrees of Freedom

UX, UY, UZ

Real Constants

None

Material Properties

EX, EY, EZ, ALPX, ALPY, ALPZ (or CTEX, CTEY, CTEZ or THSX, THSY, THSZ), PRXY, PRYZ, PRXZ (or NUXY, NUYZ, NUXZ), DENS, GXY, GYZ, GXZ, ALPD,

Surface Loads

Pressures --

face 1 (J-I-L-K), face 2 (I-J-N-M), face 3 (J-K-O-N),

face 4 (K-L-P-O), face 5 (L-I-M-P), face 6 (M-N-O-P)

Body Loads

Temperatures --

T(I), T(J), T(K), T(L), T(M), T(N), T(O), T(P), T(Q), T(R), T(S), T(T), T(U), T(V), T(W), T(X), T(Y), T(Z), T(A), T(B)

Body force densities --

The element values in the global X, Y, and Z directions.

Special Features

Birth and death, element technology auto select, initial stress import, large deflection, large strain, linear perturbation, material force evaluation, nonlinear stabilization, stress stiffening

B4. SOLID186 Homogeneous Structural Solid Element Technology

SOLID186 uses the uniform reduced integration method or the full integration method, as follows:

- **Uniform reduced integration method**

Helps to prevent volumetric mesh locking in nearly incompressible cases. However, hourglass mode might propagate in the model if there are not at least two layers of elements in each direction.

- **Full integration**

The full integration method does not cause hourglass mode, but can cause volumetric locking in nearly incompressible cases. This method is used primarily for purely linear analyses, or when the model has only one layer of elements in each direction.

B5. SOLID186 Homogeneous Structural Solid Output Data

The solution output associated with the element is in two forms:

- Nodal displacements included in the overall nodal solution
- Additional element output as shown in element output definition.

The element stress directions are parallel to the element coordinate system.

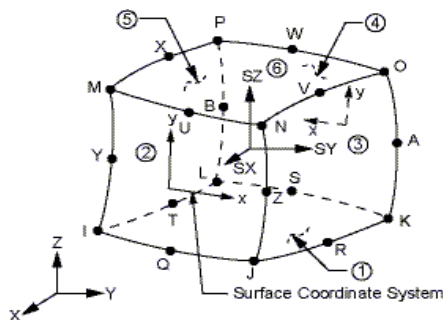

Fig.B2 SOLID186 Homogeneous Structural Solid Stress Output

B6. SOLID186 Homogeneous Structural Solid Assumptions and Restriction

The element must not have a zero volume. Also, the element may not be twisted such that the element has two separate volumes (which occur most frequently when the element is not numbered properly). Elements may be numbered either as shown in Fig.B1. Or may have the planes IJKL and MNOP interchanged.

- An edge with a removed mid side node implies that the displacement varies linearly, rather than parabolically, along that edge. Use at least two elements in each direction to avoid hourglass mode if uniform reduced integration is used (KEYOPT (2) = 0).
- When degenerated into a tetrahedron, wedge, or pyramid element shape, the corresponding degenerated shape functions are used. Degeneration to a pyramidal form should be used with caution. The element sizes, when degenerated, should be small to minimize the stress gradients. Pyramid elements are best used as filler elements or in meshing transition zones.
- For mixed formulation (KEYOPT (6) = 1), no mid side nodes can be missed, and no degenerated shapes are recommended. If you use the mixed formulation, you must use the sparse solver (default).
- Stress stiffening is always included in geometrically nonlinear analyses. Prestressed effects can be activated.

APPENDIX C

LINK 180

C1. Element Description

LINK180 is a 3-D spar that is useful in a variety of engineering applications. The element can be used to model trusses, sagging cables, links, springs, and so on. The element is a uniaxial tension-compression element with three degrees of freedom at each node: translations in the nodal x , y , and z directions. Tension-only (cable) and compression-only (gap) options are supported. As in a pin-jointed structure, no bending of the element is considered. Plasticity, creep, rotation, large deflection, and large strain capabilities are included.

By default, LINK180 includes stress-stiffness terms in any analysis that includes large-deflection effects. Elasticity, isotropic hardening plasticity, kinematic hardening plasticity, Hill anisotropic plasticity, Chaboche nonlinear hardening plasticity, and creep are supported. To simulate the tension-/compression-only options, a nonlinear iterative solution approach is necessary; therefore, large-deflection effects must be activated prior to the solution phase of the analysis. Added mass, hydrodynamic added mass and loading, and buoyant loading are available.

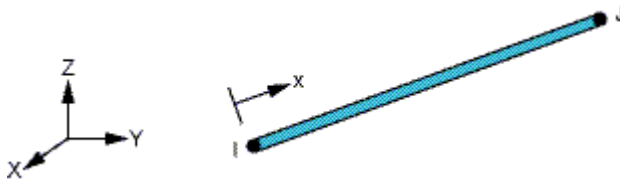

Fig.C1 LINK180 Geometry

C2. Input Data

The geometry, node locations, and the coordinate system for this element are shown in Fig. C1. The element is defined by two nodes, the cross-sectional area (A), added mass per unit length, and the material properties are input.

The element x -axis is oriented along the length of the element from node I toward node J. Temperatures may be input as element body loads at the nodes. The node I temperature $T(I)$ defaults to TUNIF. The node J temperature $T(J)$ defaults to $T(I)$.

LINK180 allows a change in cross-sectional area as a function of axial elongation. By default, the cross-sectional area changes such that the volume of the element is preserved, even after deformation. The default is suitable for elastoplastic applications. By using KEYOPT (2), you may choose to keep the cross section constant or rigid.

LINK180 offers compression-and-tension, tension-only, and compression-only options. Specify the desired behavior via KEYOPT (3).

C3. LINK180 Input Summary

Nodes

I, J

Degrees of Freedom

UX, UY, UZ

Material Properties

EX, (PRXY or NUXY), ALPX (or CTEX or THSX), DENS, GXY, ALPD, BETD

Surface Loads

None

Body Loads

Temperatures --

T(I), T(J)

Special Features

Birth and death, initial stress, large deflection, large strain, linear perturbation, ocean loading material, nonlinear stabilization, stress stiffening

C4. LINK180 Output Data

The solution output associated with the element is in two forms:

- Nodal displacements included in the overall nodal solution
- Additional element output as shown in fig below

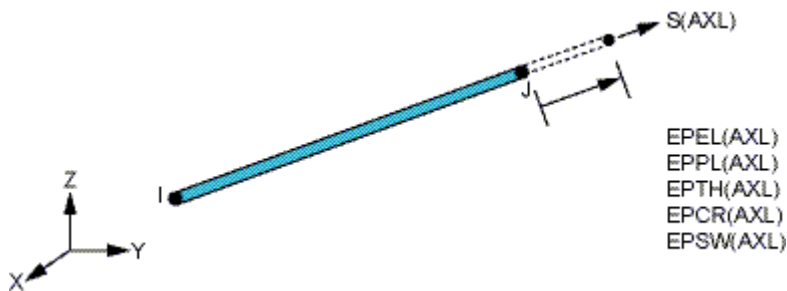

Fig.C2 LINK180 Stress Output

C5. LINK180 Assumptions and Restrictions

- The spar element assumes a straight bar, axially loaded at its ends and of uniform properties from end to end.
- The length of the spar must be greater than zero, so nodes I and J must not be coincident.
- The cross-sectional area must be greater than zero.

- The temperature is assumed to vary linearly along the length of the spar.
- The displacement shape function implies a uniform stress in the spar.
- Stress stiffening is always included in geometrically nonlinear analyses
- To simulate the tension-/compression-only options, a nonlinear iterative solution approach is necessary.
- The output axial force may not be exact when using ocean loading with nonlinear materials.