

ADDIS ABABA UNIVERSITY
SCHOOL OF GRADUATE STUDIES
FACULTY OF INFORMATICS
DEPARTMENT OF INFORMATION SCIENCE

A Case-Based Approach for Designing Knowledge-Based System for
AIDS Resource Center (ARC): The Case of Warmline Clinician
Consultation Service

By

Alemu Jorgi Muhammed

A Thesis Submitted To the School of Graduate Studies of Addis Ababa
University in Partial Fulfillment of the Requirements for the Degree of
Master of Science in Information Science

June 2010

Addis Ababa, Ethiopia

ADDIS ABABA UNIVERSITY
SCHOOL OF GRADUATE STUDIES
FACULTY OF INFORMATICS
DEPARTMENT OF INFORMATION SCIENCE

A Case-Based Approach for Designing Knowledge-Based System for
AIDS Resource Center (ARC): The Case of Warmline Clinician
Consultation Service

Alemu Jorgi Muhammed

June 2010

Name and Signature of Members of the Examining Board

Ato Mahder Alemayehu

Chair person, Examining Board

Signature

Ato Getachew Jemaneh

Advisor

Signature

Ato Tibebe Bashah

Examiner

Signature

DEDICATION

I would like to dedicate my thesis to my Dad and Mam, who passed away waiting for this achievement, and to my sisters, who encouraged me all these years.

Acknowledgement

First and for most I would like to thank God “*Allah*” who blessed me with the ability to finish this thesis and granted me success in this long-time endeavor “*Alhamdulillah*”. Next, my especial thanks go to my beloved family for their support and encouragement throughout my study.

I would like to thank my advisor Ato Getachew Jemaneh who patiently advised with scholar guidance and constructive comments on my work throughout this endeavor. My thanks also go to Dr. Million Meshesha and Dr. Sebsbie H/Mariam for their valuable and unreserved support from the development of the research proposal to the final write up of the thesis.

I am also greatly indebted to Ali yassin, Abdu Seid and Solomon Abebe who helped me in giving valuable comments and editing the paper at the time of this work.

My deep appreciation and thanks extended to the AIDS Resource Center (ARC) especially the Warmline staff, particularly Dr. Adfirs Beyene and Dr. Fatuma Seid for their cooperation during the knowledge acquisition. My deeply felt gratitude also goes to the Department of Information Science and its entire staff for their support throughout my stay as a graduate student. I would also like to express my appreciation to the wonderful friends I have had at the Department of Information Science most of whose my group members.

Last but not least, I would like to acknowledge my friends at home, Abinew Ali, Ebrahim Chekol and Miftah Hassen, for making my life prettier and making all those hardships I had to go through easier.

Alemu Jorgi Muhammed

Table of Contents

Acknowledgement	ii
List of Tables	vii
List of Figures	viii
List of Acronyms	ix
List of Appendices	xi
Abstract	xii
CHAPTER ONE	1
INTRODUCTION	1
1.1 Background	1
1.2 The Statement of the Problem and Justification	4
1.3 The Objectives of the Study	8
1.3.1 General Objective	8
1.3.2 Specific Objectives	8
1.4. Methodology of the Study.....	9
1.5 Scope and Limitation of the Study.....	10
1.6 Application of the Study.....	10
1.7 Organization of the Thesis	11
CHAPTER TWO.....	12
REVIEW OF THE LITERATURE (1)	12
2.1 Artificial Intelligence.....	12

2.2 Knowledge-Based Systems (KBS) Background	13
2.2.1 Knowledge-Based System Structure	13
2.2.2 Approaches for Designing Knowledge-Based Systems	15
2.3 Overview of the Case-Based Systems.....	18
2.3.1 Significance Case-Based Reasoning	19
2.3.2 Architecture of Case-Based Reasoning	20
2.3.3 CBR Problem Areas /CBR Process.....	22
2.4 Techniques in Case-Based Reasoning (CBR).....	27
2.4.1 CBR Tools.....	27
2.4.2 Selection of Case-based Reasoning Tools	28
2.4.3 Case-Based Framework for JCOLIBRI	28
2.5 Related Research Works	31
2.5.1 Knowledge-Based System in Medical Domain	31
2.5.2 Knowledge-Based System for HIV/AIDS	33
CHAPTER THREE	36
REVIEW OF THE LITERATURE (2)	36
3.1 Background of the Problem Domain	36
3.2 The Challenges of Person Living with HIV/AIDS (PLWHA)	37
3.3 Care, Support and Follow Up of PLWHA	38
3.4 Telephone Consultation Service Systems in Ethiopia.....	40
3.4.1 Warmline (Telephone Consultation Services).....	41
3.4.2 HIV/AIDS Treatment as Prevention.....	42
3.4.3 HIV/AIDS Treatment (Antiretroviral Therapy)	43

CHAPTER FOUR	49
RESEARCH DESIGN AND METHODOLOGY.....	49
4.1 Introduction.....	49
4.2 Study Area.....	49
4.3 Study Subjects	50
4.4 Knowledge Source	50
4.5 Knowledge Acquisition procedures	50
4.6 Sampling Techniques.....	51
4.7 Data Preparation for Analysis.....	51
4.8 CBR Design and Implementation Tool.....	52
4.8.1 Design and building the CBR model-----	52
4.8.2 CBR Implementation Tool -----	53
4.9 Testing and Evaluation.....	54
CHAPTER FIVE	55
KNOWLEDGE ACQUISITION AND CONCEPT MODELLING	55
5.1 Knowledge Acquisition	55
5.1.1 Knowledge Acquisition from Domain Expert -----	56
5.1.2 Knowledge Acquisition from Relevant Documents -----	56
5.2 Knowledge Modeling.....	57
5.3 Knowledge Acquisition to Identify Case Feature.....	58
5.3.1 Modeling Concept to Manage ADR Associated with ARV -----	58
5.3.2. Concepts of some Signs and Symptoms of PLWHA -----	60
5.3.3. Modeling the Concepts of Patients Factors-----	63

5.3.4 Concept Modeling for Patients' Current Medication -----	65
5.3.5. Concepts for CD4 Count and Viral Load Test for the Patients-----	68
5.3.6 Other Medication-----	70
CHAPTER SIX	72
DESIGN, IMPLEMENTATION AND PERFORMANCE EVALUATION	72
6.1 Introduction.....	72
6.2 Designing CBR in HIV Case Knowledge-Based System	72
6.3 Case-Based Reasoning System for ADR Case Patients	73
6.3.1 Building the Case-Base -----	74
6.3.2 Case Representation -----	75
6.3.3 Managing Connectors -----	80
6.3.4 Managing Task/ Methods-----	81
6.3.5 Deploy the CBR Application -----	85
6.4 Testing and Performance Evaluation	86
6.4.1 Experimental Setting-----	86
6.4.2 Testing the Prototype CBR System-----	86
6.4.3 Evaluation of the Performance of the System.....	95
CHAPTER SEVEN	103
CONCLUSIONS AND RECOMMENDATIONS	103
7.1 Conclusion.....	103
7.2 Recommendation	105
References	107
Appendices.....	114

List of Tables

Table 5.1 Input and Output of ADR Associated to ARV... ..	58
Table 6.1 Selected Features for the ADR Description.....	76
Table 6.2 Selected Attributes for ADR Case Management.....	78
Table 6.3 Performance of Similarity Measure.....	92
Table 6.4 Evaluation of Case Test Similarity.....	93
Table 6.5 Relevant Cases Assigned by Domain Experts for Sample Test Case.....	96
Table 6.6 Performance Measure Precision-Recall.....	97
Table 6.7 Performance Evaluation for Previous Researches.....	98
Table 6.8 The Performance Evaluation of the System by Domain Experts (group I).....	100
Table 6.9 Performance Evaluation of the System by Domain Experts (group II).....	101

List of Figures

Fig. 2.1 Structure of KBS.....	14
Fig. 2.2 CBR Cycle Adopted from Aamodt & Plaza (1994).....	21
Fig. 2.3 JCOLIBRI Architecture Adopted from Stoyanov & Govedarova (2005).....	29
Fig. 5.1 Case Concept for Determining Drug Toxicity of ADR.....	60
Fig. 5.2a Concepts in Managing Diarrhea.....	61
Fig. 5.2b Concepts in Managing Rash Hypersensitivity.....	62
Fig. 5.2c Concepts in managing fever.....	62
Fig. 5.3 Cases involved in Concepts of Patients Factor to Treat ADR.....	63
Fig. 5.4 Concepts to Patients' Profiles.....	64
Fig. 5.5 Status of Patients and Current Medication Condition.....	65
Fig.5.6 Concepts of Poor Adherence which Result in Adherence.....	66
Fig. 5.7 Cases for Treatment Failures and Switching.....	68
Fig. 5.8 Concepts of CD4 Count to Confirm the Clinical Status of the Patient.....	69
Fig. 5.9 Concepts for Clinical and Laboratory State during ADR.....	70
Fig. 5.10 Treating ADR when ARV interacts with other Medication.....	71
Fig. 6.1 Architecture of CBR for HIV/AIDS Case Consultation Service.....	73
Fig. 6.2 Main Window JCOLIBRI.....	74
Fig. 6.3 Defining the Case Structures.....	79
Fig. 6.4 Plain Text XML Schemas.....	80
Fig. 6.5 Configuring Connectors.....	80
Fig. 6.6 Managing Tasks/Methods.....	85
Fig. 6.7 Windows for Case Entry into the Case-Base	85

List of Acronyms

ACTG - AIDS Clinical Trial Group

ADR-Adverse Drug Reaction

AI- Artificial Intelligence

AIDS- Acquired Immunodeficiency Syndrome

API-Application Programming Interface

ARC-AIDS Resource Center

ART-Antiretroviral Treatment

ARV- Antiretroviral

ASCII -American Standard Code for Information Interchange

CBO-Community-Based Organizations

CBR-Case-Based reasoning

CCP- Center for Communication Programs

CD4- Cluster of Differentiation 4

CDC- Centers for Disease Control and Prevention

CTSHIV- Customized Treatment Strategies for HIV

EFV- Efavirenz

GUI-Graphical User Interface

HAART- Highly Active Antiretroviral Therapy

HAPCO-HIV/AIDS Prevention and Control Office

HIV- Human Immunodeficiency Virus

JCOLIBRI- Java Class Ontology Libraries Integration for Building Reasoning Infrastructure

KBS-Knowledge-Bases System

MOH-Ministry Of Health

NCCC-National Clinician Consultation Service

NFV Nelfinavir

NGO-Non-Governmental Organization
NNRTI-Non-nucleoside Reverse Transcriptase Inhibitors
NVP- Nevirapine
OI-Opportunistic Infections
PACTG- Pediatric AIDS Clinical Trials Group
PEP- Post Exposure Prophylaxis
PEPFAR- US President's Emergency Plan for AIDS Relief
PIs-Protease Inhibitors
PLWHA-Person Living with HIV/AIDS
PMTCT-Prevention of Mother to Child Transmission
RBS-Rule- Based System
UNAIDS- Joint United Nations Program on HIV/AIDS
UNICEF- United Nations Children's Fund
VCT-Voluntary Counseling and Testing
WHO-World Health Organization
XML-Extended-Markup Language

List of Appendices

Appendix I: Sample Questions that were asked during the Interview with Domain Experts....	114
Appendix II: Application Design Using JCOLIBRI 1.1.....	115
Appendix III: Case Similarity Query Result Window	118

Abstract

The study was conducted with the aim to explore the potential of case-based reasoning (CBR) in solving complex side effects of HIV/AIDS cases for PLWHA who have already begun antiretroviral therapy. The knowledge was acquired from domain experts using semi-structured interview and discussion. Then knowledge modeling was employed using hierarchical tree structure that represents concepts and parameters very easily. Based on the model, the knowledge was represented using the case-based reasoning approach. The CBR system was developed using JCOLIBRI version 1.1, which is the most compatible and reliable CBR tool to deal with case-based system.

The most important part of a Case-Based Reasoning model includes case retrieval; the similarity measuring stage, reuse; which allows domain expert to transfer retrieval case solution to suit for the current case, revise; to test the solution and retain to store the confirmed solution to the case-base. For a new case patient, whose recommendations was not yet to be confirmed and who had an indefinite circumstances, the CBR model was effectively used to retrieve solution for the new case at hand based on previous similar solved cases . These similar cases could provide useful information to the clinicians, in reaching a potential solution for the new case.

The prototype developed in this study was evaluated to measure its performance. User acceptance test and statistical analysis (i.e. precision and recall) were the two scenarios that the researcher used to evaluate the performance of the prototype for this study. As evaluated by domain experts in the Warmline, the performance of prototype showed promising result. Moreover, the performance of the prototype was evaluated using recall/precision calculations. Thus, an average recall value of 72%, with an average precision of 63% has been achieved in the study. Encouraging results were registered for overall performance of the prototype. In general, the system has basically achieved the goal since the main objective of the system was to find the potential useful similar cases efficiently for the users.

CHAPTER ONE

INTRODUCTION

1.1 Background

Due to the rapid spread of HIV/AIDS with an alarming rate throughout the world, the number of people infected with HIV or ill with AIDS continues to increase. New estimations have recently resulted in substantial changes in number of persons living with HIV worldwide. Currently, number of persons living with HIV worldwide is 33.2 million (UNAIDS and WHO, 2007). Everyday, over 6800 persons become infected with HIV and over 5700 persons die of AIDS, mostly because of inadequate access to HIV prevention and treatment services (UNAIDS and WHO, 2007). Nowadays, it is true that many people are living with the virus. As the number of people living with HIV/AIDS (PLWHA) rises at higher rate, there is a need to better manage the patients, and to respond quickly to their problems for appropriate care, treatment, advice and follow-up.

In Ethiopia, the national HIV/ AIDS Resource Center (ARC) was established in 2002 through a multi-dimensional public/private partnership including the Centers for Disease Control and Prevention (CDC), Johns Hopkins Bloomberg School of Public Health/Center for Communication Programs (CCP), Ethiopian Government HIV/AIDS Prevention and Control Office (HAPCO) and various international and local government and non-government organizations (NGOs) (Hopkin, 2005).

As mentioned in ARC (2009), despite the recent campaign in improving access to treatments are significant victories in fighting against HIV/AIDS in Ethiopia, the low ratio of experienced HIV-care providers per infected patient poses another significant obstacle, mainly in rural areas of the country. Doctors, nurses, pharmacists and other health-care professional altogether play an integral role in providing quality care, but many of them do not have a specialized knowledge and skills necessary for managing complex HIV treatment regimens.

To fill this gap, ARC established the Fitun Warmline which is fully functional since May 2008. The Warmline provides expert clinical advice on HIV/AIDS management for health-care

providers, from those with limited access to expert consultation to those with complex antiretroviral therapy (ARC, 2009). It also supports the health-care-workers to stay current on the latest information about HIV/AIDS.

Likewise, according to Telecommunication and Health-Care (2008), Warmline has a great role in the country in providing telephone based informational services that have been successfully used to provide HIV/AIDS clinical advice and education to less experienced health-care providers.

Health-care workers in the country can contact the Warmline by dialing 932 free of charge from anywhere through the telephone call. The National HIV Telephone Consultation Service (Warmline) established in Addis Ababa at AIDS Resource Center offers clinicians' free consultation services in HIV care. This service provides prompt consultation to clinicians working at different hospitals and clinics throughout the country (ARC, 2009). The consultation service for the health-care includes adverse drug reaction, drug interaction, prevention of mother to child transmission, recommendations for post exposure prophylaxis, treatment against opportunistic infections, selection of combination antiretroviral (ARV) drug regimens and treatment failure.

The experts working on Warmline hear the cases as the health-care workers enquire HIV cases, when possible, they answer the questions immediately. For more complex cases, the domain experts discuss the issue together to produce a reliable and informative answer and then return the call within a few hours.

To be successful, health-care organizations must provide competitive services that are valued by patients. One of the promising approaches is to integrate computer technology and artificial intelligence into health services. In the recent health-care literature, application of knowledge-based systems (KBSs) has been reported and it has been proved that advanced technology can help to improve health service qualities (Ling and Li, 1999).

KBS is a sub-field of Artificial Intelligence (AI) that works on knowledge-base for effective decision making by imitating the behavior of human expert within a well-defined, narrow

domain of knowledge. It mainly focuses on knowledge and uses inference to solve problems. Thus, KBSs are more recognized in medical domain due to its ability to reason over extensive knowledge-bases and to learn ideas and update its knowledge-base regularly (Tan, 2008).

KBS has come across a variety of approaches based on the knowledge-representation methods and the reasoning strategies applied during implementation. Rule-based reasoning (RBR) and case-based reasoning (CBR) are two popular approaches used in knowledge-based systems (Prentzas and Hatzilygeroudis, 2007).

Rules usually represent general knowledge, whereas cases encompass knowledge accumulated from specific (specialized) situations (Ling and Li, 1999). One of the major characteristic of a RBS is the handling of problems with a well-defined knowledge-base that contain rules. It uses a deductive approach to deduce solutions from a set of rules. However, in partially understood domain this approach may become impractical (Prentzas and Hatzilygeroudis, 2007). The system may not cover deep knowledge of the complex, internal mechanisms of the problem domain. It suffers from a number of limitations. It is unable to deal with open texture problems, i.e. existing rules may not match the problem exactly, and therefore assessments made only on the basis of rules. It is also unable to deal with domain complexity and with structural details in solving a problem.

This problem may be solved using a CBR, which can solve problems by incorporating past experiences, even in a partially understood domain. Hence, CBR could work in problem domains where the underlying models used for solutions are not well understood. Historically, CBR has shown its greatest success in areas where individual cases or precedents govern the decision-making processes (Prentzas and Hatzilygeroudis, 2007).

In line with this, Popa (2008) found that CBR is a basic problem solving technique that uses and adapts the solutions of analogous past problems to solve new problems. The primary goals of AI research in CBR are to identify the ways that human reasoners draw conclusions from comparing cases, and where possible, to design computer programs to implement these methods or to assist humans to perform tasks (Ashley, 1992). Thus, it can provide an alternative to rule-based expert

systems, and is especially appropriate when the number of rules needed to capture an expert's knowledge is unmanageable or when the domain theory is too weak or incomplete (Lopez, 2001).

1.2 The Statement of the Problem and Justification

The Human Immunodeficiency Virus (HIV) has created enormous challenges worldwide. The diseases are now still common and very dangerous in many countries of the world especially in developing nations like Ethiopia. The number of People Living with HIV/AIDS (PLWHA) in Ethiopia is about 1.1 million with 7.7% and 0.9% prevalence rate in the urban and rural population respectively and 134,450 have already died of AIDS (MOH and HAPCO, 2007). This shows that Ethiopia is one of the countries which is most heavily affected by the epidemic.

In 2009, AIDS Resource Center reported that 3,500 health-care workers with more than 420 sites are providing antiretroviral treatment (ART) services to more than 180,447 patients in Ethiopia. Despite advances in treatment, the occurrence of side effects on PLWHA and managing the cases at all sites in the country are the major problems faced by health-care professionals. In determining the problems of PLWHA, doctors, nurses, pharmacists and other health-care professionals confront with many difficulties: the patients' symptoms are usually unclear and difficult to distinguish (Phuonga, n.d). Doctors always have to try and refer many times before making a decision. Consequently, the decision depend not only the patients' symptoms but also the doctors' experiences, because a wrong decision means, a wrong treatment and the patient would die (Phuonga, n.d).

As discussed with domain experts working in the Warmline, on average, they received 400 calls about different HIV cases in a week. Dr. Adefris (personal communication, March 21, 2010) at Warmline explained that the majority of these calls originated from all over the country stress on the complex issues for the provisions of antiretroviral therapy. Among the different HIV cases that need antiretroviral therapy: adverse drug reaction/side effects, opportunistic infectious diseases, prevention of mother to child transmission, post exposure prophylaxis, drug interaction, and treatment failures are the most commonly encountered problems.

In addition to this, Assegid (2007) noted that the antiretroviral drug (ARV) medication on some people cause severe adverse reaction that impose dose reduction or discontinuation of treatment, others have presented side effects that are uncomfortable or annoying and can interfere with their daily quality of life. Assegid also explained that the frequency of ADRs among patients who were on ARV drugs was found out to be 24% of the total population under taken for the study as compared to the total HIV/AIDS cases encounter on PLWHA. ADR classified as mild (no medical intervention/therapy required), moderate (no or minimal medical intervention/therapy required), severe (change one or more drug, or change regimen medical intervention/therapy required), and life threatening (which involve discontinuation of medical intervention/therapy required). Severe and life threatening of the ADR patients who were on ARV drug account 19%, which is higher as compared to any other country.

HIV/AIDS consultation services and treatments at various situations demand high level experts' knowledge and practical experience about the particular cases involving HIV patients (ARC, 2009). This in turn requires availability of qualified manpower at various levels, including hospitals, clinics and other health-care centers where HIV/AIDS consultation services are offered. However, the practical situations in Ethiopia dictate that there is a significant shortage of qualified manpower. As a result, the existing system could not address all the problems occurred on PLWHA due to the following limitations:

- There are many health-care professionals that are calling to the Warmline domain expert(s) that in turn creates workload.
- The call service is not accessible at the required level
- It is not as effective as face-to-face evaluation by experts since there are many cancellation of call which poses communication barriers.

So, the aim of this research is to address the problems that were discussed so far in focusing the following major problems.

- Patients on HAART commonly suffer from side effects.
- The risk of the side effects varies from drug to drug, drug class to drug class and patient to patient.

- Experts may have different views on the same case which results service inconsistency due to high complexity, uncertainty, and subjectivity nature of the side effects.

Thus, establishing good consultation service is a fundamental part of the treatment, care and support for PLWHA which is one of the simplest means to help people live longer and more productive lives. The majority of PLWHA live in countries where health-care, resources and experts are scarce (ARC, 2009). For them, good advising and treatment system is a right way to respond to the illness.

These are researches done to investigate the application of KBS in the area of HIV/AIDS. For instance, Anteneh (2004) attempted to design a knowledge-based system in antiretroviral therapy. In addition, Redit (2006) developed knowledge-based system for HIV pre-test counseling. Both researcher works tried to address the problem using a rule-based reasoning approach. A rule-based knowledge-based system is based on the general knowledge domain which cannot deal with cases when deviated from the general rules (Ling and Li, 1999). Furthermore, it is characterized by poor scalability and inflexibility. That means inclusion of new knowledge or updating of existing knowledge usually means redesign of at least a part of the system. It performs poorly outside their boundaries (i.e. it is restricted with facts and rules that are in the knowledge-base but not when new cases are encountered). In addition, due to its closed-world assumption, RBS requires that all facts be known to the system otherwise, unknown facts are false (Luan et al, 2005).

However, most of the medical domains, particularly in HIV/AIDS, involve cases which have incomplete rule and ill-defined challenges that can be unsolved using the conventional RBS, so the CBR is the appropriate choice to handle the problems.

Thus, the problem can be addressed using CBR which can be made to learn by continuing to the CBR method by remembering and reusing information from a previous similar experience (Maher, 1995). New problem could be solved using CBR in such a way that adapting and combining old solutions to solve a new problem, to critique new situations based on old cases. Maher (1995), also described the advantage of CBR is that as the complexity of the knowledge-base increases, a CBR knowledge-base system is probably easier to maintain rather than a rule-

based system. For example, it is easier to add, modify or delete a case in a CBR system as opposed to changing rules, which often requires a lot of restructuring in a rule-based system.

Therefore, to alleviate the above mentioned problems and to expand the consultation service all over the country, there should be an alternative solution to control the harshness of the disease. In this regard, the application of KBS and utilization of up to date technologies could be utmost important. Hence, this study has attempted to design a case-based reasoning knowledge-based system that can assist domain experts to provide appropriate treatment and consultation service to those people living with HIV/AIDS.

In general, shortage of high level experts in the area of HIV/AIDS motivated the researcher to focus on representing and modeling domain knowledge of experts in the field so that the research output would serve as a highlight to provide expertise consultation service in the area where specialized experts are unavailable.

1.3 The Objectives of the Study

The research has the following general and specific objectives

1.3.1 General Objective

The general objective of this research was to explore the applicability of CBR for developing a knowledge-based system that could assist the domain experts in providing efficient and effective treatment and consultancy services for PLWHA.

1.3.2 Specific Objectives

The following specific objectives were set to achieve the general objective of the study.

- To review documents in order to understand concepts and principle of knowledge-based system and available technologies.
- Acquire the necessary tacit and explicit knowledge required to build the knowledge-based system using interview and detailed discussion with domain experts at ARC, Warmline, in particular.
- Explore and extract the procedures and domain knowledge in national HIV/AIDS Telephone Call Consultation Service.
- Construct a case structure comprising of relevant attributes that have a direct impact on diagnosis and treatment of HIV/AIDS patients.
- Design the knowledge model that is suitable for case-based reasoning for HIV/AIDS treatment and consultation service.
- Build the case-base comprising of various HIV/AIDS patients' cases in order to implement the CBR model.
- Develop a case-based prototype knowledge-based system for the CBR model
- Evaluate the prototype system to measure its performance and report the findings.
- Make conclusions and recommendations as future research areas.

1.4. Methodology of the Study

In order to achieve the objectives of the research, literature review, identification of knowledge source, knowledge capturing, sampling technique, knowledge representation, selection of system development tools, testing and experimenting of the system, and evaluation were employed. Exhaustive literature review was conducted to investigate concepts and principles in KBS, especially in CBR. In addition, literature on the HIV/AIDS, especially those dealing with side effect of antiretroviral drugs on PLWHA and their challenges was reviewed. Besides, to investigate what others have done on KBS, in HIV/AIDS, reviewing of the available related research works was conducted.

The domain knowledge was acquired from both primary and secondary sources using interviews, direct observation and documents such as books, journals, magazines and proceedings and the Internet to understand the problem area in-depth. Using the purposive sampling techniques, five experts were selected and semi-structured interview was conducted to acquire the required tacit knowledge from domain experts. The acquired domain knowledge was modeled using hierarchical tree structure. The reason for choosing hierarchical tree structure is its simplicity and ease of use to model the knowledge.

The knowledge was modeled using the hierarchical tree structure and implemented using case-based reasoning system. The system used the case in the form of case features or attribute-value pairs to represent the domain knowledge. A prototyping approach was used to design the KBS so that the system has been tested first for its feasibility before taking on the complete task of designing and implementing the system. For the purpose of developing the prototype and knowledge representation JCOLIBRI was used. JCOLIBRI was preferred due to its flexibility and the various features it provides for the development of the desired system. JCOLIBRI uses simple to complex case structure and represents cases in very simple way. JCOLIBRI stores cases in text and database such that it manages big case-bases in a very efficient way. It also facilitates CBR system design by providing graphical tool.

The validity of the expert system was tested using the test dataset to check its performance with the domain experts. Decision of human experts on previous cases is compared with the systems

recommendation in order to proof its applicability in HIV/AIDS. To test the performance of the prototype, the researcher used test dataset. Then the actual users evaluated the prototype by taking user feedback and standard measure of system performance (precision and recall).

1.5 Scope and Limitation of the Study

Even though there are many problems in the HIV/AIDS area, due to shortage of time and scarcity of resources, the scope of the research was limited to the development of a prototype KBS for the national HIV/AIDS Telephone Call Consultation Service (Warmline) of AIDS Resource Center in Ethiopia. The study considered people living with the virus and faced challenges with different HIV cases treated in the domain of clinician consultation service. To develop the KBS, a series of steps were followed including knowledge acquisition, knowledge modeling, indexing and storage, retrieval, case adaptation and retain along with the integration of CBR. However, the study focused on the CBR retrieval and adaptation phase of the CBR model. Due to the complexity and limited time available, ADR/side effects of antiretroviral drugs cases were considered for representation in the case-base, rather than all the HIV cases available. This is due to the high prevalence of adverse drug reaction (ADR) among HIV-infected person on antiretroviral therapy in Ethiopia as compared to other mentioned HIV cases (Assegid, 2007). The prototype does not involve incorporating the other HIV cases in the case-base (i.e. opportunistic infections, PMTCT, drug interaction, PEP, treatment failures).

1.6 Application of the Study

The significance of this study could be stated as follows:

- The AIDS Resource Center of Ethiopia could apply the output of this research in order to improve the limitations of the current consultation service system and provide effective clinician information services to its users.
- The outcome of the study is highly useful to those health-care providers working at hospitals, clinics and others. The system might provide timely, complete, consistent and relevant information concerning care, support and treatment of HIV/AIDS patient cases.

- As provision of efficient advisory and treatment services about HIV/AIDS cases, person living with HIV/AIDS (PLWHA) will be the beneficiary of this research output.
- The overall result of this research would contribute to the effort of improving and prolong the quality of life for PLWHA in general and reduce the harshness of the virus and confront of side effects in particular.
- This research might serve as a base for future researchers in the area.

1.7 Organization of the Thesis

The whole work of this thesis was organized in seven chapters. The first chapter dealt with background information about HIV/AIDS and knowledge-based system. It also consisted of statement of the problems, objectives of the study and discusses the scope and the methodology followed throughout this research. The second chapter comprised literature review on case-based reasoning (CBR), detailed discussion was presented about the CBR techniques used to solve CBR problems, architecture of CBR, and problem area of CBR, framework of JCOLIBRI including other CBR tools. Review of related research works on medical and HIV/AIDS were also included.

The third chapter provided background information in HIV/AIDS. It also dealt with challenges and their care, support and follow-up of PLWHA, current clinician consultation service for the research setting area, HIV/AIDS treatment and treatment as prevention, adverse drug reaction and opportunistic infection disease.

The fourth chapter described research design and methodology. This part dealt with all the necessary steps and techniques to apply in this thesis. It includes data collection methods and procedures, design and building of the CBR model, selection tool for implementation, and testing and validation was presented. In chapter five, the knowledge acquisition and modeling knowledge of domain experts using hierarchical tree was presented. Chapter six was devoted to the discussion of the implementation and evaluation of the system. Chapter seven gives final conclusions and forward recommendations for future studies.

CHAPTER TWO

REVIEW OF THE LITERATURE (1)

2.1 Artificial Intelligence

Rao et al (1999) described that Artificial Intelligence (AI), as a discipline, has grown enormously during the past decades. Its application today spans the realm of manufacturing, finance, management and medicine. Implementation of the appropriate AI technique in an application is often a must to satisfy competitive needs.

Moreover, Kashyap (1997) stated that:

“AI is the subfield of computer science that attempts to develop machines that are capable of emulating human thought processes. In other words, the ability of a machine to perform tasks thought to require human intelligence i.e. modeling the behavioral aspect of human reasoning and learning. Typical applications include game playing, language translation, expert systems, and robotics .”

AI's scientific goal is to understand intelligence by building computer programs that exhibit intelligent behavior. It is concerned with the concepts and methods of symbolic inference or reasoning by a computer and how the knowledge used to make those inferences will be represented inside the machine (Engelmore and Feigenbaum, 1993). According to Engelmore, and Feigenbaum (1993), the term intelligence covers many cognitive skills, including the ability to solve problems, learn, and understand language; AI addresses all of these concepts. But, most progress to date in AI has been made in the area of problem solving concepts and methods for building programs that reason about problems rather than calculate a solution.

Tadele (2005) citing Forsyth (1986) explained that the 1970's is the period that AI researchers shifted their focus from developing generally intelligent machines to solving real world problems. As a result, KBS turned out to be one of the first emerged fields of applied AI. Often, the term KBS is reserved for programs whose knowledge-base contains the knowledge used by

human experts, in contrast to knowledge gathered from textbooks or non-experts (Engelmore, & Feigenbaum, 1993).

2.2 Knowledge-Based Systems (KBS) Background

KBS is a branch of Artificial Intelligence that has become a reality in the systems development world nowadays. KBSs are usually embedded in other applications, performing knowledge-specialized tasks (De Parga, 2009). Moreover, Sajja (2008) stated that KBS is productive tool of AI working in a narrow domain to impart quality, effectiveness, and knowledge-oriented approach in decision making process.

KBS is the result of a long investigation process performed by Artificial Intelligence scientists. It is an Artificial Intelligence based tool that works on knowledge-base for effective decision making in more human oriented way using the expert knowledge (De Parga, 2009). It must have the capability to make logical inferences based on the knowledge stored. KBSs are very domain-specific. Typically, a medical knowledge-base system cannot be used to find faults in the design of an electrical circuit (Kashyap, 1997).

Hence, KBS is a group of computer programs that tries to emulate, and even do better than in some situations. The idea is not to replace human thinking by a machine, just the expertise of a competent professional (De Parga, 2009).

2.2.1 Knowledge-Based System Structure

In order to design KBS, it is necessary to become familiar with the way such systems are structured. A KBS has three levels of organization: knowledge-base, working memory and an inference engine. Apart from these, it has a user interface which permits the user to interact with the system (Kashyap, 1997). Fig.2.1 shows the relationship between these parts of a KBS.

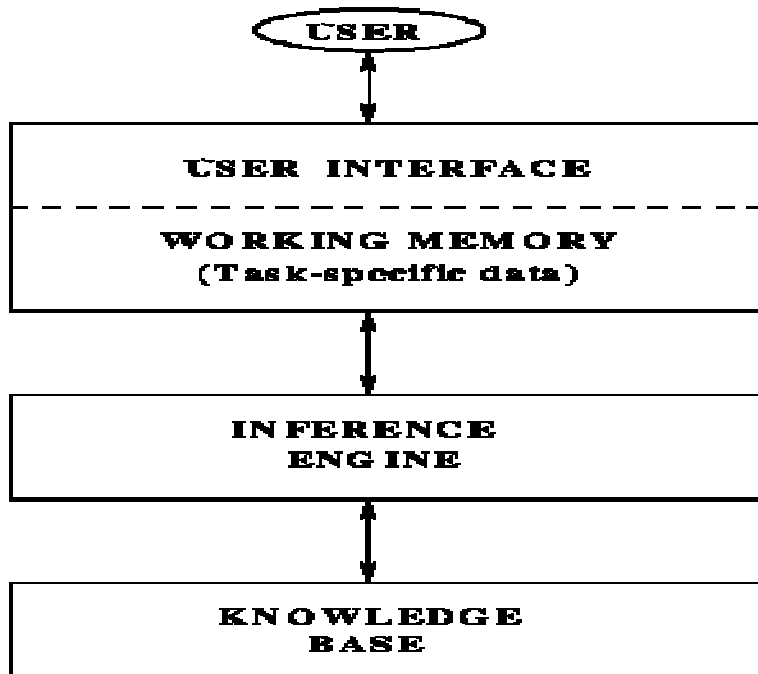

Fig.2. 1 Structure of Knowledge-Based systems Adapted from Kashyap (1997)

The structure and components of KBS as explained by (Kashyap, 1997) are the following:

Knowledge-Base

The knowledge-base is the facts and rules part of the KBS. It contains the formal representation of the knowledge provided by the domain experts. This knowledge may be in the form of problem-solving such as cases, procedures, or data intrinsic to the domain.

Inference Engine

Having a knowledge-base alone is not of much use if there are no facilities for navigating through and manipulating the knowledge to deduce something from facts stored in knowledge-base. Therefore, an inference engine in the KBS is a need to solve the actual problems in generating solution from the facts to arrive at some conclusion.

Working Memory/Task Specific Data

It is like a temporal-auxiliary memory that stores the user data, initial problem data, hypothesis, and intermediate results during the inference process. Through it, we can know the current

system status and how it was reached. The best way to store this information is in relational databases, rather than in other rudimentary systems.

User Interface

The user interface can make communication between the knowledge-based system and the user possible. The user interacts with the system through a user interface in dialog form between the user and the system which may use in the form of menus, natural language or any other style of interaction.

Users

Those are the individuals who use the system for their problem solving assistance or the individuals who will be consulting the system to get advice which would have been provided by the expert.

2.2.2 Approaches for Designing Knowledge-Based Systems

Different approaches have been used to develop a KBS. Among those different approaches, RBR and CBR are the two most familiar and well known approaches (Lopez, 2001).

Conventional rule-based expert systems use human expert knowledge to solve real-world problems that normally would require human intelligence. Expert knowledge is often represented in the form of rules or as data within the computer (Abraham, 2005). A KBS developed using RBR encodes its knowledge in the form of “If...Then “rules, where, “IF condition /premises, THEN, action/conclusion”. Thus, RBR systems solve problems by following a generative approach, typically rule-chaining, in which they create a deductive path from the evidence (facts) to the hypotheses (goals).

Although this approach is widely used, Prentzas & Hatzilygeroudis (2007) found that the following were some of the drawbacks that observed in this approach.

Brittleness of rules: With rule-based knowledge-based systems, it is not possible to draw conclusions from rules if missing values appear in the input data. For a specific rule, a certain number of condition values must be known in order to evaluate the logical function connecting

its conditions. In addition, rules do not perform well in cases of unexpected input values or combinations of them.

Inference efficiency problems: In some condition, the performance of the inference engine may not be well performing, as the size of rules in the knowledge-base becomes very complex.

.Scalability: Inference handles each problem from scratch, whether it has dealt with the same problem successfully in the past or not. That is why rule-based inference usually faces the scalability problem.

Difficulty in maintenance of large rule-bases: Maintaining of rule-base knowledge-based system is a difficult task in complex rule situations. The rule-base may have problems such as redundant rules, conflicting rules, rules with redundant or missing conditions, missing rules etc.

Problem-solving experience is not exploited: A rule-based system is not self-updatable, in the sense that there is no inherent mechanism to incorporate experience acquired from dealing with past problems. Such experience could contribute decisively in the inference process, as it could assist in handling special cases or exceptions not expressed by rules.

Interpretation problems: In dealing with a specific situation, rules may sometimes need to be specialized, but rule-base is effective in general problem domain.

On the other hand, CBR can provide an alternative to rule-based expert systems, and is especially appropriate when the number of rules needed to capture an expert's knowledge is unmanageable or when the domain theory is too weak or incomplete. CBR can work in problem domains where the underlying models used for solutions are not well understood (Lopez, 2001).

In general, CBR has more advantages as compared to rule-base reasoning in some areas of problem domain. According to Shiu and Pal (2004), the advantages of CBR from various points of view include:

- Avoiding repeating mistakes made in the past

The reasons for failure as well as success to problems were recorded in attempting to solve the case. As a result, information about what caused failures in the previous case can be used to expect potential failures in the future.

- Providing flexibility in knowledge modeling

CBR systems uses past experience to solve current problems by adapting or revising solution.

However, others like rule-based systems, due to their rigidity in the problem formulation and modeling, they cannot solve problems when they encounter some missing or incomplete data.

- Reasons in domains that have not been fully understood, defined or modeled

A case-based reasoner can still work using only a small set of cases from the domain despite in a condition where insufficient knowledge exists to derive solutions for problems at hand.

- Making prediction of the probable success of proffered solution

In CBR system, the past solution for a case is stored in the case-base for future use. When similar cases are arising, the case-based reasoner tried to derive the solution for current problems. This is done by referring previous stored solution, its level of success of these solution, and differences between pervious and current reasons of cases.

- Learn over time

The main feature of CBR over rule-base reasoning is the ability to learn as they express more problems and get solutions. As solutions of cases are frequently tested and level of success is determined, then these cases can be added into the case-base along with their proper solutions and helps solving future problems.

- Reasons with incomplete or imprecise data and concepts

Since retrieved cases may not always be similar to the current query cases, or due to the increased disparity between the current and retrieved cases, any incomplete and imprecision data and concepts can be dealt by the case-base reasoner still continue.

- Avoiding repeating all the steps that need to be taken to arrive at a solution

In RBS that requires significant processes to create a solution from scratch, the CBR approach of modifying a previous solution can significantly reduce the processing requirement.

- Extending to a broad range of domains

CBR can be applied on various numbers of application domains. This is due to the appearing of unlimited number of ways representing, indexing, adapting and retrieving cases.

Hence, the limitation that in counter in the rule-based system, case-based reasoning approach was selected for this study.

2.3 Overview of the Case-Based Systems

CBR has grown, in part, out of the more general field of AI. Lützelschwab (2007) stated that, the field of CBR has a relatively young history and has its origin in research being done in cognitive science. Shiu and Pal (2004) described that CBR focused on problems such as how people learn a new skill, and how humans generate hypotheses about new situation based on their past experiences.

Since the late 1970s, many CBR applications have been developed by research institutes or industrial companies in order for solving specific domain problems (Abdrabou & Salem, 2008). In addition, there are several tools or shells that have been built to facilitate the building of a CBR application by non-programmer users. Most of these tools aim to provide Application Programming Interfaces (APIs) which provide a set of functions that deal with CBR algorithms and methodologies. They are intended to help programmers to embed these APIs in their application development. In order to access more complex problems the research goes to provide an open development environment that lead users to more uniform tool at the level of design.

During the period 1977 to 1993, CBR research was highly regarded as a plausible high-level model for cognitive processing. It mainly focused on problems such as how people learn a new skill and how humans generate hypotheses about new situations based on their past experiences (Abdrabou & Salem, 2008).

CBR has become one of the greatest tools for solving problems and learning in the recent years. This approach has spread all over the world within a very short period after originating in the US. CBR is fundamentally different from other AI approaches as it derives the solutions for problems from experience. That is to say, several pieces of experience are stored in the system as cases, usually called old cases, and when a new case is encountered, it is solved similarly to a similar old case stored in the system. Nowadays many people or organizations, such as physicians, drilling engineers, financial consultants etc, use CBR techniques for solving complicated problems (Selam, 2007).

2.3.1 Significance Case-Based Reasoning

According to Ashley (1992), a case is described as a particular set of empirical circumstances presenting a problem for decision, solution or classification as an instance of a type. It particularly presents the circumstances and situation of a discrete episode, action, person, or thing. It is empirical in that it deals with something that actually exists or happens. It presents a problem for decision, that is, circumstances constituting a matter for consideration and analysis resulting in an outcome. Finally, a case is an instance or example of the particular type of outcome, the category under which it has been classified, or the concept which the decision maker has applied.

The basic format of a case comprises of: problem, solution, and result. The problem describes the state of the situation and any constraints. The solution contains the action taken to correct the problem and the result holds the information that describes the level of success or failure that was achieved when the response was applied to the problem (Miller, 2009). Based on what is included in a case, the case can be used for a variety of purposes (Salem, 2007):

- Cases that include a problem description and solution can be used in deriving solutions to new problems;

- Cases that include a problem description and outcome can be used in evaluating new situations and
- Cases that have a specified solution can be used in evaluating proposed solutions and anticipating potential problems before they occur.

Accordingly, CBR can mean different things depending on the intended use of the reasoning: adapt and combine old solutions to solve a new problem, explain new situations according to previously experienced similar situations (Lopez, 2001). Similarly, (Kolodner 1993) cited in (Miller ,2009) explained CBR is intended to mimic that people typically use to solve problems. This is the use of past experiences to reason about new situations. CBR is used to solve new similar problems, explain new situations, critique new solutions, or to create an equitable solution.

2.3.2 Architecture of Case-Based Reasoning

The CBR principle is based on an analogy to the human task of “mentally searching for similar situations which happened in the past and reusing the experience gained in those situations” (Lützelschwab, 2007).

According to Aamodt & Plaza (1994) the problem solving life cycle in a CBR system consists essentially of the following four parts:

- Retrieve most similar case or cases

During this process, the system seeks the cases from case-base to find the most approximate case or cases to the current situation.

- Reuse the cases to attempt to solve the problem

The domain expert evaluates the ranked search results in order to decide if the solution retrieved is applicable to the problem.

This process includes using the retrieved case and adapting it to the new situation. At the end of this process, the reasoner might propose a solution.

- Revise the proposed solution if necessary

The solution is revised (adapted) manually (by the user) or automatically (by the CBR system) to make the solution best match for the problem at hand.

- Retain the new solution as a part of a new case

This process enables CBR to learn and create a new solution and a new case that should be added to the case-base. The confirmed solution is retained with the problem, for future situation, as a new case in the knowledge-base. Fig. 2.2 shows a graphical representation of the typical CBR cycle:

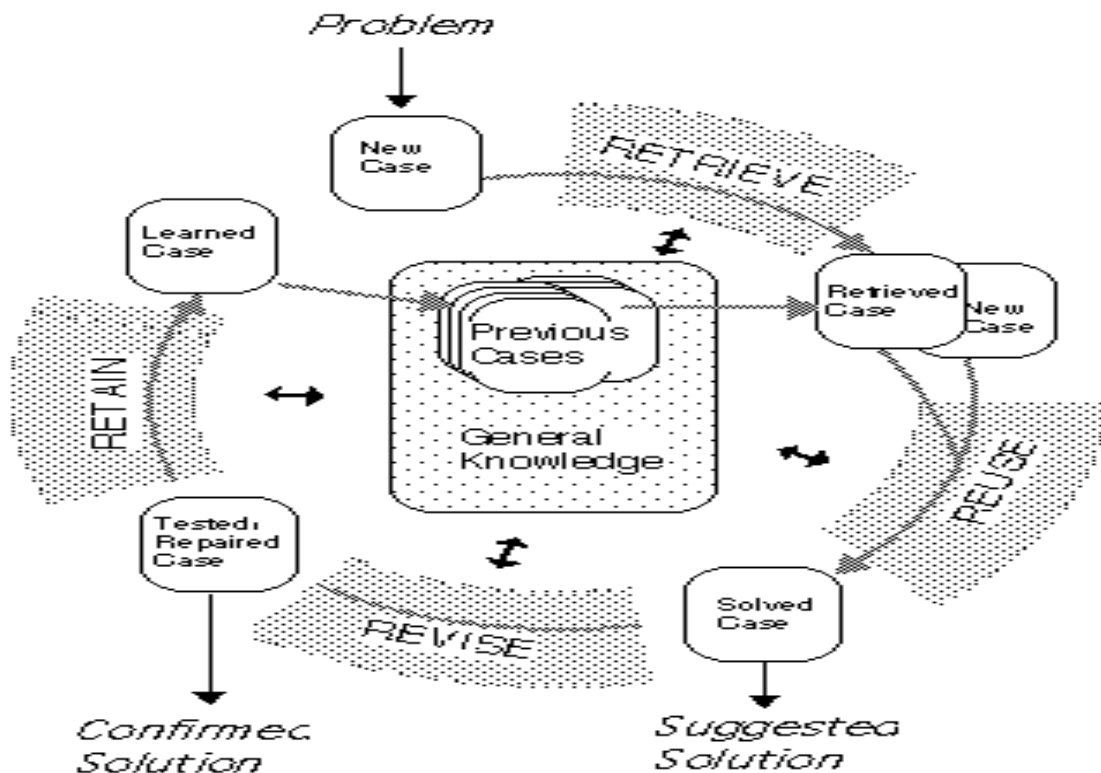

Fig 2.2: CBR Cycle Adopted from Aamodt and Plaza (1994).

Figure 2.2 show that how a CBR system solves new problems by adapting solutions to previous solved cases that are stored in knowledge-base. By receiving a new input, the best matching case is searched in the case-base and an appropriate solution is retrieved. Having retrieved cases from

the case-base, the retrieved solution is adapted to fit the new problem. If the solution fails, explain the failure and learn it, to avoid repeating. If the solution succeeds and warrants retention, incorporate it into the case memory as a successful solution.

With this regard, Lützelschwab (2007) revealed that in situations where a previous identical case is retrieved, assuming that its solution was successful, it can be offered as a solution to the current problem. In the more likely situation that the case retrieved is not identical to the current case, an adaption phase occurs. During adaption, differences between the current and retrieved cases are first identified and then the solution associated with the case retrieved is modified, taking these differences into account. The solution returned in response to the current problem specification may then be tried in the appropriate domain setting.

2.3.3 CBR Problem Areas /CBR Process

The challenge in CBR, as elsewhere, is to come up with methods that are suited for problem solving and learning in particular subject domains and for particular application environments. According to Aamodt and Plaza (1994) found that core problems addressed by CBR research can be grouped into the following areas. These are case representation, indexing, storage, retrieval and adaptation. Now, let's discuss these techniques.

2.3.3.1 Case Representation

Determining the appropriate case features is the task for knowledge engineering in CBR systems. A case-based reasoner is heavily dependent on the structure and content of its collection of cases often referred to as its case memory (Aamodt & Plaza, 1994). It contains the information content of case and situation where that information or experience can be used. Besides, Salem (2007) said that case representation involves defining the terminology of the domain and gathering representative examples of problem solving by the expert. In addition cases can be represented in a variety of forms using the full range of AI representational formalisms including frames, objects, predicates, semantic nets and rules - the frame/object representation currently being used by the majority of CBR software (Watson & Marir, 1994).

The representation problem in CBR is primarily the problem of deciding what to store in a case, finding an appropriate structure for describing case contents, and deciding how the case memory should be organized and indexed for effective retrieval and reuse. An additional problem is how to integrate the case memory structure into a model of general domain knowledge, to the extent that such knowledge is incorporated (Aamodt & Plaza, 1994).

As mentioned by Ashraf and Iqbal (2006) citing Pal and Shiu (2004), to represent cases with appropriate format, the following factors should be considered.

- Language or shell to implement CBR system. The selection of shell may reduce the number of formats for case representation.
- Indexing and search mechanism. The format of case should be selected according to search mechanism.
- Type or structured associated with content. These types must be available in case representation.

A case is a combination of components. Components are description of a problem and its solution. Problem description consists of a set of attributes and values. Thus, these attributes predict a solution. Therefore, selecting appropriate case representation language, shell, and format should be the task of the knowledge engineer in the design and implementation of case-based knowledge-based systems.

2.3.3.2 Case-Indexing Process

Case indexing involves assigning indices to cases to facilitate their retrieval (Watson & Marir ,1994). The CBR system derives its power from its ability to retrieve relevant cases quickly and accurately from its memory. Figuring out when a case should be selected for retrieval in similar future situations is the goal of the case indexing process.

As mentioned by Watson and Marir (1994) and Ashraf, and Iqbal (2006), indices should have the following features:

- Be predictive.
- Should show the purpose for which case will be used.

- It must address future use of case-base.
- It should be easy to recognize it in feature.

According to Watson and Marir (1994), indices can be done manually or automatically. Choosing indices manually involves deciding a case's purpose with respect to the aims of the reasoner and deciding under what circumstances the case will be useful.

On the other hand automatic indexing involves the following process (Watson & Marir, 1994; Ashraf & Iqbal , 2006):

- Indexing cases by features and dimensions that tend to be predictive across the entire domain i.e., descriptors of the case which are responsible for solving it or which influence its outcome.
- Difference-based indexing selects indices that differentiate a case from other cases
- Similarity and explanation-based generalization methods, which produce an appropriate set of indices for abstract cases created from cases that share some common set of features, whilst the unshared features are used as indices to the original cases
- Inductive learning methods which identify predictive features that are then used as indices. These techniques are widely used and commonly use variants of the ID3 algorithm used for rule induction.
- Explanation-based techniques, which determine relevant features for each case.

2.3.3.3 Case-Memory Organization or Storage

One important aspect in efficient CBR system is case storage. Once cases are represented and indexed, they can be organized into an efficient structure for retrieval. Case storage is an important aspect in designing efficient CBR systems. It should reflect the conceptual view of what is represented in the case and take into account the indices that characterize the case. The case-base should be organized into a manageable structure that supports efficient search and retrieval methods. A balance has to be found between storing methods that preserve the semantic richness of cases and their indices and methods that simplify access and retrieval of relevant cases (Watson & Marir, 1994).

2.3.3.4 Case Retrieval

Building a structure or process that will return the most appropriate case (from the case memory) is the goal of the retrieval process (Salem, 2007). The retrieve task starts with a partial problem description, and ends when a best matching previous case has been found. Its subtasks are referred to as identify features, initially match, search, and select, executed in that order. The identification task basically comes up with a set of relevant problem descriptors; the goal of the matching task is to return a set of cases that are sufficiently similar to the new case given a similarity threshold of some kind, and the selection task works on this set of cases and chooses the best match. According to Watson & Marir (1994), the following are the most common and familiar case retrieval approaches.

Nearest-Neighbor

This approach involves the assessment of similarity between stored cases and the new input case, based on matching a weighted sum features. The biggest problem here is to determine the weights of the features. In general, the use of this method leads to the retrieval time increasing linearly with the number of cases. Therefore this approach is more effective when the case-base is relatively small. A typical algorithm for calculating nearest neighbor matching is:

$$\text{Similarity } (fI, fR) = \frac{\sum_{i=1}^n w_i \times \text{sim}(f_i^I, f_i^R)}{\sum_{i=1}^n w_i}$$

Equation 2.1 Formula for Nearest-Neighbor algorithms adopted from Watson & Marir (1994).

Where:

- w =weighting of a feature (or slot),
- sim = similarity function for attributes i in cases fI and fR
- fI = the values for feature i in the input cases.
- fR = the values for feature i in the retrieved cases
- n = number of attributes in each case

Induction

Induction algorithms (e.g. ID3) determine which features do the best job in discriminating cases, and generate a decision tree type structure to organize the cases in memory. This approach is useful when a single case feature is required as a solution, and where that case feature is dependent upon others.

Knowledge Guided Induction

This method applies knowledge to the induction process by manually identifying case features that are known or thought to affect the primary case feature. This approach is frequently used in conjunction with other techniques, because the explanatory knowledge is not always readily available for large case-bases.

Template Retrieval

Similar to SQL-like queries, template retrieval returns all cases that fit within certain parameters. This technique is often used before other techniques, such as nearest neighbor, to limit the search space to a relevant section of the case-base.

2.3.3.5 Case Adaptation

It is a technique to alter retrieved case for reproducing new solution for new problem (Ashraf & Iqbal, 2006). Once a matching case is retrieved a CBR system should adapt the solution stored in the retrieved case to the needs of the current case. Adaptation looks for prominent differences between the retrieved case and the current case and then applies formulae or rules that take those differences into account when suggesting a solution. Case adaptation improve overall problem solving ability of CBR. In general, there are two kinds of adaptation in CBR (Ashraf & Iqbal, 2006):

- Structural adaptation, in which adaptation rules are applied directly to the solution stored in cases.
- Derivational adaptation that reuses the algorithms, methods or rules that generated the original solution to produce a new solution to the current problem. In this method, the

planning sequence that constructed that original solution must be stored in memory along with the solution. Derivational adaptation, sometimes referred to a re-instantiation, can only be used for cases that are well understood.

2.4 Techniques in Case-Based Reasoning (CBR)

2.4.1 CBR Tools

CBR tool is software that can be used to develop several applications that require CBR methodology (Abdrabou & Salem, 2008). Many CBR tools have been developed for the application of CBR. Accordingly, Abdrabou and Salem (2008) identified the following CBR tools.

CASPAIN: This is a CBR tools written in C language which can run on operating systems like; MS DOS, MAC, or UNIX with no graphical user interface. It performs simple nearest-neighbor matching to retrieve cases from the database. Store cases including adaptation rules, in the form of an ASCII file.

CASUEL: This is a common case representation language developed by European INRECA project (Integrated reasoning from cases). It supports rule formalism for exchanging case completion rule as well as case adaptation mechanism for defining similarity measures. This tool doesn't support to store cases in different file format.

CBR-WORK: This is a kind of CBR shell supports all the required tools to model, maintain and consult a case-base. CBR-works is running on MS window, MAC, OS/2 and various UNIX platforms. It also supports an object oriented model and flexible retrieval methods.

JCOLIBRI: The application framework of JCOLIBRI comprises a hierarchy of JAVA classes plus a number of XML files. The framework is organized around four main elements: tasks and methods, case-base, connectors, and JCOLIBRI core. It represents cases in a simple way and supported by different data types which define any cases. As compared to other CBR tools, it is more powerful in representing, store and adaptation mechanism. It supports many types of adaptation mechanism and has many ways to represent cases.

CASE ADVISOR: This is another CBR tool which is very easy to use and suitable for simple case-based diagnostic systems. But, as compared to JCOLIBRI, it is not powerful and does not offer many features.

2.4.2 Selection of Case-based Reasoning Tools

For this study selection of appropriate tools for effective representation, indexing, organization/storing and retrieval of cases is the first task for the successful implementations of the system. After a review of a variety of available CBR tools, JCOLIBRI has been selected. JCOLIBRI is a software artifact that promotes software reuse for building CBR systems. It can integrate the application of well proven software engineering techniques with a knowledge level description (Recio-Garcia and Daz-Agudo, 2004).

The researcher motivation for choosing this tool is based on a comparative analysis between JCOLIBRI and other frameworks. Such as availability (open source framework), implementation (the Java implementation implies to a great extend usability, extensibility and user acceptance), GUI (the provided graphical tools facilitate the system design). Another decision criterion is connected with the fact JCOLIBRI affords the opportunity to incorporate ontology in the CBR system to use it for case representation and content-based reasoning methods to assess the similarity between them (Stoyanov, Govedarova, & Popchev, 2005).

2.4.3 Case-Based Framework for JCOLIBRI

JCOLIBRI framework shows a hierarchy of java classes and number of XML files (Ashraf & Iqbal, 2006). A framework can be considered as a semi-complete application that can be specialized to produce custom applications. It can be applied in a wide range of domain, and can be enhanced by adding new components (Abdrabou & Salem, 2008). JCOLIBRI framework comprises: case-base (in-memory organization of cases), task and method, and JCOLIBRI core modules ((Stoyanov, Govedarova & Popchev, 2005). It also shows the four different data source types (Persistence Layer), which are connected with the other framework components via objects, referred to as Connectors.

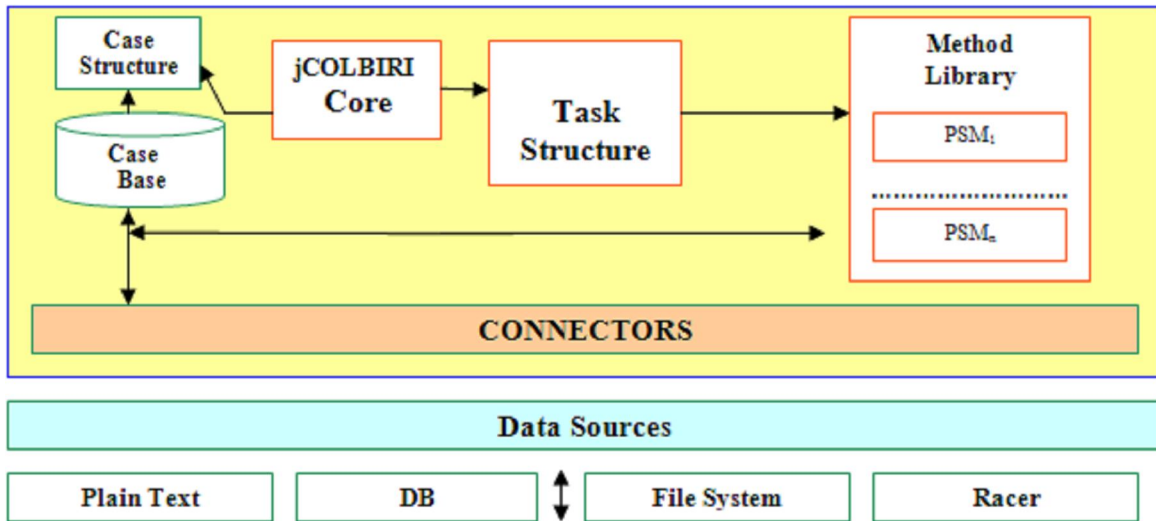

Fig. 2. 3. JCOLIBRI Architecture Adopted from Stoyanov, Govedarova and Popchev(2005)

The design of the framework using JCOLIBRI comprises a hierarchy of Java classes plus a number of XML files organized around the following elements (Stoyanov, Govedarova & Popche, 2005):

2.4.3.1 Case Structure

A case represents an actual happening of the past. It needs to make this information available in a form suitable to be reused and eventually adapted to the new problem. A case is defined in a certain structure and holds the essential information to the specific problem that has been solved with this case (Lützelshwab, 2007). JCOLIBRI represents a case in a very general way. The framework support several case structures, from plain attribute value records to hierarchical trees with composed attributes.

There are two types of attributes: simple and compound. Simple attributes are described by name, type, weight and local similarity function whereas compound attributes collect other simple or compound attributes allowing complex case structures. The properties of the compound attributes are the name and the global similarity function. When two cases are compared, the local similarity functions are used to compare simple attribute values. Global similarity functions are linked to compound attributes and are used to gather similarities of the collected attributes in a unique similarity value. At last the similarity value of two cases is

computed as the similarity of their description concepts (Recio, 2002) & (Stoyanov, Govedarova & Popchev, 2005).

2.4.3.2 Case-Base and Connectors

As mentioned by Recio et al. (2002), the cases can be stored in relational databases, ASCII text files, XML files, etc. The designer has to define the storage and retrieval mechanism, and how to index the cases in memory to increase the speed of the queries. JCOLIBRI has a memory organization interface that assumes the whole case-base can be read into memory for the CBR to work with it. CBR systems access store cases in an efficient way. But, problem occurs when size of case-base grows. JCOLIBRI manages the problem when the size of case-base grows as follows (Recio et al, 2002):

✓ Persistency Mechanism

Persistency is built around connectors. A connector represents the first layer of JCOLIBRI on top of the physical storage. Connectors are objects that know how to access and retrieve cases from the medium and return those cases to the CBR system in a uniform way. The use of connectors give JCOLIBRI flexibility against the physical storage. Thus, the system designer can choose the most appropriate connector for the designing of the system (Recio et al., 2002). JCOLIBRI can be implemented in the following different types of connectors (Bello-Tomás González-Calero and Díaz-Agudo, 2004):

- File system connector to retrieve cases stored in XML files.
- JDBC connector that makes possible the use of JCOLIBRI with most of the databases available in the market.
- RACER connector that allows the designer to use RACER, a description logics system, as source for cases.

✓ In-Memory Organization

The second layer of Case-base Management is the Case-base (data structure) used to organize the cases once read and loaded by the connector into memory.

2.4.3.3 Tasks/ Methods

Tasks are the key elements that represent the method goal and can identify it by name and description in an XML file. XML files explain tasks supported by the framework and the methods to solve these tasks (Abdrabou & Salem, 2008). The most well-known knowledge level analysis applied to CBR systems describes the general CBR cycle in terms of four tasks (4 Rs) at the highest level of generality (Recio-Garcia and Daz-Agudo, 2004): retrieve the most similar cases, reuse their knowledge to solve the problem, revise the proposed solution and retain the experience. Each one of the CBR tasks involves a number of more specific subtasks. Each one of the four CBR tasks involves a number of more specific sub-tasks. Moreover, JCOLIBRI has additional methods to solve the preparation and maintenance tasks which are named as pre cycle (loads the cases from data sources) and post cycle (stores the learned cases in the persistence layer).

2.4.3.4 JCOLIBRI Core

The core is the actual code that supports the methods included in the framework. Stoyanov, Govedarova & Popchev (2005) explained that the core is the most important component of the framework. It is in charge of maintaining the CBR configuration and executing the application. When a user generates a CBR application template, it generates the Java code that configures the core components with the appropriate tasks, methods, data types and case structures. The core is composed of CBRstate (maintains the tasks and method configuration), CBRcontext (contains the case-base and working-cases), Packages (manage the remaining components, such as similarity functions, case structure).

2.5 Related Research Works

2.5.1 Knowledge-Based System in Medical Domain

The application of IT research and development to support health and medicine is an emerging research area with significant potential. Major initiatives to improve the quality, accuracy and timeliness of health-care data and information delivery are emerging all over the world (Masizana-Katongo, Leburu-Dingalo and Mpoeleng, 2009). The applications of IT including

KBS have been used to carry out efficient and effective knowledge processing on complex problems to support various problem domains since the 1970's.

Research works have been conducted in the field of expert systems for medical domain. Even though the output of these researches have their own limitations, important achievements have been obtained and produced significant contribution to the present stage of KBS. The most popular application of expert systems in the area of health and medicine are described below:

According to Masizana-Katongo, Leburu-Dingalo and Mpoeleng (2009) citing Jackson (1986), MYCIN was one of the early rule-based expert systems used for medical diagnosis developed in the Stanford University. It was the most popular medical expert systems used to aid physicians in diagnosing and treating patients with infectious blood diseases caused by bacteremia (bacteria in the blood) and meningitis (bacterial that causes inflammation of the membrane surrounding the brain and spinal cord). MYCIN was the pioneer in demonstrating how a system can be used to successfully perform medical diagnosis. Clinical knowledge in MYCIN is represented as a set of IF-THEN rules with certainty factors attached to diagnoses. It was a goal directed system, using a basic backward chaining reasoning strategy (resulting in exhaustive depth-first search of the rules base for relevant rules though with additional heuristic support to control the search for a proposed solution).

Another early expert system is the PACE (Patient Care Expert System) developed by Evans (1996) cited in Masizana-Katongo, Leburu-Dingalo and Mpoeleng (2009) which was conceived in 1977 with the purpose being to make "intelligent selections" from the overwhelming and ever changing information related to health in order to facilitate patient care. The system started off as an educational system for the nursing profession. Throughout the years the system evolved and went through many development generations to a point where it became an advanced clinical management system capable of supporting the entire health-care field to diagnose and care for patients with pulmonary diseases.

In addition, INTERNIST I, was an experimental computer-based diagnostic consultant for general internal medicine. INTERNIST-I was a rule-based expert system designed at the University of Pittsburgh in 1974 for the diagnosis of complex problems in general internal

medicine. It uses patient observations to deduce a list of compatible disease states based on a tree-structured database that links diseases with symptoms (Miller et al., 1982 cited in Kumar, Singh and Sanyal, 2009).

Matsopoulos et al. (2004) cited in Masizana-Katongo, Leburu-Dingalo and Mpoeleng (2009) designed an expert system called, MITIS system at the National Technical University of Athens. The MITIS system was developed to assist in the management and processing of obstetrical, gynaecological, and radiological medical data. The concept behind this system is to record and store information from experts in medical departments of gynaecology, radiology and obstetrics to provide a centralized mechanism for managing patient information within and outside a hospital.

All these expert systems mentioned above were developed using rule-based approach. Despite the rule-based expert system approach paradigm is powerful; it has some drawbacks when applied to medical problems (Luan et al, 2005).

- The knowledge acquisition process for most medical applications is challenging even not covered with rules. A medical domain expert system requires detailed knowledge, but much of the rule-based approach is represented in the form of IF-THEN statements.
- The acquired knowledge from the medical domain is highly context-dependent in most cases which are not covered with general rules.
- Rule-based expert systems are inflexible with poor scalability. Inclusion of new knowledge or updating of existing knowledge usually means redesign of at least a part of the system. This can cause serious problems for many medical applications. For instance, HIV/AIDS treatment strategy evolves quickly as their understanding of the disease and its treatment deepens. For instance, the U.S. Public Health Service updates its HIV/AIDS treatment guidelines at least once a year.

2.5.2 Knowledge-Based System for HIV/AIDS

HIV and AIDS information is required to be accurate, timely and easy to understand. As it is essential that HIV and AIDS information distributed should be from an expert source, KBSs are preferential ways to undertake this task.

The advent of HIV and AIDS has prompted the development of KBS in this problem domain (Luan et al, 2005). In the recent years, researchers are developing KBSs on HIV and AIDS to assist mainly medical practitioners.

The Customized Treatment Strategies for HIV (CTSHIV) was one of the KBS for management of HIV-Infected Patients. CTSHIV expert system was developed at the University of California Irvine as a tool that "...recommends individualized treatment strategy for HIV patients..." The concept behind the system is to analyze the strains of HIV in a patient and find out what antiretroviral agent the strain is resistant to. Based on this information the system is then able to determine which antiretroviral drugs are appropriate for that particular patient. Although CTSHIV is aimed at physicians as a diagnostic tool, it does have the advisory capabilities in that it refers users to more information in respect to recommendations being generated (Kumar, Singh and Sanyal, 2009; Pazzani Michael et al., 1999).

Redit (2006) designed a prototype knowledge-based system for HIV pre-test counseling. As she indicated in the thesis the primary objective of the work is to look into the feasibility of employing the expert system technology to the area of pre-test counseling using the knowledge Pro Gold expert system shell. The system was able to demonstrate the applicability of the expert system technology to the area of voluntary counseling and testing at a satisfactory level. The major limitation that is observed in her work is that rule-based systems perform poorly outside their boundaries (i.e. it is restricted facts and rules which is in knowledge-base but not when new cases are arriving). It doesn't solve problems using past experience. Some of this is due to the closed-world assumption, which requires that all facts be known to system, implying that unknown facts are false. As a result, pure rule-based representations are too weak to represent the complexities of the real world either effectively or efficiently.

In addition, Anteneh (2004) has done a rule-based system to design and develop a prototype knowledge-based system for antiretroviral therapy. In his study, he made an effort to explore applicability of knowledge-base system in antiretroviral therapy to assist in the choice drug for individual patients which mainly focus on prescribing regimens for "treatment-naïve" patients only. However, the system suffered from lack of consultancy service like managing of side

effects and follow-up of patients on HAART therapy when they are suffering by different side effects associated with antiretroviral drugs.

So, the main challenges of HIV/AIDS for both health-care professionals and PLWHA are the adverse event, drug interaction, treatment against opportunity infection;. Hence, without adequate management of these side effects, antiretroviral drugs will not be maintained at sufficient concentrations to suppress HIV replication and lower the plasma viral load. This indicates that there are still researches worthy issues with respect to enhancing the functionality of the system and uncover problem domain in the area of HAART therapy.

In this study, it is observed that there is a need for creating case-based reasoning for handling new cases due to poor performance of rule-based systems outside their boundaries and unseen circumstances, because making HIV/AIDS treatment decision is far more complex than most other diseases.

CHAPTER THREE

REVIEW OF THE LITERATURE (2)

3.1 Background of the Problem Domain

The Human Immunodeficiency Virus (HIV) has created an enormous challenge worldwide. It has spread further, faster and is expanding its scope with more disastrous long-term effects than any other disease. Since its recognition, HIV has infected close to 70 million people, and more than 30 million have died due to Acquired Immunodeficiency Syndrome (AIDS) worldwide (HAPCO & MOH, 2007).

Nearly 34 million people in the world are currently living with HIV/AIDS, and 31.3 million of these are adult people. As 2.7 million of people worldwide become newly infected in 2008, the epidemic continues to grow. As a result, the total number of people living with the virus in 2008 was more than 20% higher than the number in 2000, and the prevalence was roughly threefold higher than in 1990 (UNAIDS & WHO, 2009).

In 2008, as UNAIDS reported around 22.4 million of people living with HIV/AIDS in the world were living in Africa, with HIV prevalence rate in the general population of 5.2%. Of the total number of people living with the virus in Africa, more than 67% are living in sub-Saharan region, where AIDS is the leading cause of death. In Africa, continued treatment scale-up and HIV prevention efforts are bringing results in some countries, but mortality from AIDS remains high in sub-Saharan Africa due to the extensive unmet treatment need (UNAIDS, 2009).

Ethiopia is one of the countries that hardly hit by HIV/AIDS epidemic in the Sub Saharan Africa. According to the MOH (2007) based on Single Point Estimate “AIDS in Ethiopia Report” there will be more than 1.2 million people living with the virus, prevalence of adult infection is 2.4% (urban 7.7%, rural 0.9%), and of these 397,818 require ART, in the same year, it is estimated that, 28,073 people will die of the endemic by the year 2010.

In addition, HAPCO (2009) revealed that HIV/AIDS has been and still is the greatest challenge to the Ethiopia health system, like other most sub-Saharan African countries. It has remained among the major causes of deaths of adults so far. In 2007, UNAIDS&WHO estimated that everyday, over 6800 persons become infected with HIV and over 5700 persons die of AIDS, this is the reason that lack of adequate access to HIV prevention and treatment services. Now, the HIV pandemic remains the most serious of infectious disease challenges to public health in Ethiopia.

This shows that AIDS remains a leading cause of mortality which results greatly disrupts the economic and social bases of families. As adult group mostly affected with the virus, loss of human capital become high; this in turn affects labor and production. Moreover, the illness and impending death will result an enormous impact on national productivity and earnings.

To minimize the above risks, the country should make much effort on individual, family, community, institutional, regional and national levels to provide preventive, treatment, care and support for person living with HIV/AIDS.

3.2 The Challenges of Person Living with HIV/AIDS (PLWHA)

Studies show that PLWHA and their families confront major challenges in their workplace, living home as well as in addressing the impact of HIV/AIDS on their quality of life. Many are forced to leave their jobs due to persistent stigma and discrimination or they simply become too ill to continue working. They lose essential income that they need to cover their medical expenses and the basic living costs for themselves and their households. HIV-related stigma can negatively impact social relationships, access to resources, social support provision and the psychological well being of PLWHA. As a consequence, PLWHA faced not only the physical and psychological consequences of their infection; they are also suffered with stigmatizing reactions from others (Stutterheim, 2008).

Although many PLWHA may want to know more about information related to HIV virus, the stigma attached to the individual, lack of clarity and transparency from them, faced trouble in

getting the services provided by different agencies. As result, lack of access to this information was hindering from effective utilization of the existing continuum of care, support and treatment services. Moreover, a failure to assess and prioritize the actual felt needs of recipients was also mentioned as one of the constraints, which seriously limited benefits of the existing services (Family Health International, 2004).

A further shortcoming due to fear of stigma and lack of transparency with PLWHA leads difficulty in getting appropriate services. For instance, they can't visit voluntary counseling and testing (VCT) center, which constitutes an important part of the continuum of care and support services, particular provided by a number of indigenous and international non-governmental organizations (NGOs).

However, care, support, adherence, comprehensive and specialized medical services for PLWHA to prolong and improve quality of life was emphasized. Besides, clarity and transparency having to tell others they are HIV-positive, can make easy for them to ask questions or get the information they need.

3.3 Care, Support and Follow Up of PLWHA

In addition to treatment, care and support are the main issues for those PLWHA for the well being of others and themselves. They all need support to relieve the challenges of illness. However, much research indicates that, until recently, HIV prevention efforts in most countries, including Ethiopia, are focused primarily on encouraging the majority of people, those not at risk, to engage in safe sex practices. Among the safer sex practices promoted are: abstaining (A) from having sex or delaying of sexual debut, being faithful (B) to a single sexual partner, and avoid having multiple sex partners and using condoms (C) consistently when having sexual intercourse (Strebel, Cloete & Simbayi, 2009).

This has meant that people who know they are HIV positive have been largely ignored regarding prevention efforts in the HIV epidemic. Soon after, it has been recognized that there are a lot of people affected by the virus despite HIV prevention strategies focused on promoting people to

engage in safe sex. In order to be successful, the strategies of HIV policy program efforts also have to target PLWHA.

As described previously, Ethiopia is one of the seriously affected countries in sub Saharan Africa. With more than 1.1 million people living with HIV and an estimated 397,818 people requiring treatment, as result of this, the government of Ethiopia has taken measures to reduce loss of life due to HIV and mitigate the impact of the epidemic on society (MOH, 2007). Thus, providing high-quality and comprehensive interventions for social mobilization as well as HIV/AIDS prevention, treatment, care and support are challenging task requiring cooperation among a wide range of stakeholders at different levels of the health-care system (MOH&HAPCO, 2007).

As Ministry of Health and HIV/AIDS Prevention and Control Office (2007) explained social mobilization in the context of HIV/AIDS response stated that:

“It is a movement aimed at creating community involvement and ownership to address problems related to HIV/AIDS prevention, control, treatment, care and support. It focuses on participation of all possible sectors and civil society in mobilization of local resources, use of indigenous knowledge and enhancement of people’s creativity and productivity through mass campaigns. The concept has an extremely positive significance, since real change can be accelerated through joint efforts against the HIV/AIDS epidemic.”

As a result, the government policy on HIV/AIDS in Ethiopia give attention towards the implementation of preventive programs and the provision of rehabilitative services to those already infected and affected by the virus. Since HIV/AIDS is not curing diseases, the care and support system constitutes the core of the rehabilitation component of the policy. Currently, various governmental and nongovernmental agencies as well as community-based organizations (CBOs) are actively involved in addressing the problems that occurred in PLWHA through care and support services (Family Health International-Ethiopia & HAPCO, 2002).

Further, in response to the epidemic, the government of Ethiopia issued an HIV/AIDS policy in 1998. It subsequently established HAPCO and the National AIDS Council, and took several steps to prevent further disease spread, and to increase accessibility to HIV/AIDS care, treatment and support for persons living with HIV/AIDS. In July 2003, the government adopted the policy of ARV drug supply and use, paving the way for additional initiatives that facilitate access to free and low-cost ARVs. In January 2005, the government launched the free ARV treatment initiative (MOH & HAPCO, 2007). The expected continued increase in HIV/AIDS patient load throughout the country, resulting difficult challenges for existing health-care providers for rapid scale-up and intensive follow-up of patients on treatment.

On behave of this, the government of Ethiopia took further steps in increasing accessibility to HIV care, treatment and support for persons living with HIV by establishing appropriate national consultation services to address problems faced by health-care providers in their working clinics or hospitals . Among these, the National AIDS Resource Center (ARC) in Addis Ababa was established to improve access to quality HIV/AIDS care and treatment in Ethiopia. Currently, this organization is known by providing relevant and authenticated HIV/AIDS related information for all PLWHA in the country and expert consultation for health-care providers caring for PLWHA. To run this program effectively, the HIV/AIDS Twinning Center established a partnership linking the ARC in Addis Ababa with the National Clinicians' Consultation Center (NCCC) of the University of California, San Francisco (UCSF), Department of Family Medicine, to strengthen ARC's capacity to implement a telephone consultation service, or Warmline, that provides clinical information and advice to health-care providers caring for PLWHA and ultimately improve access to quality HIV/AIDS care and treatment.

3.4 Telephone Consultation Service Systems in Ethiopia

The AIDS Resource Center (ARC), a nongovernmental organization in Ethiopia has been designated to serve as source of authentic and relevant information related to HIV/AIDS and other allied areas for both PLWHA and health-care workers that give care for those HIV infected throughout the country. Both Hotline and Warmline in ARC use telephone call system to provide HIV/AIDS related information to their clients remotely. Most Hotline calls originate from the

general population in the country which need information about basic and simple question for HIV related issues. Thus, it seems simple and not requiring high level experts to answer the questions. On the other hand, most Warmline calls originate from Health-care workers and concerned to antiretroviral therapy, including managing side effects of HIV case, interpreting drug resistance tests, selecting drug regimens, HIV testing and managing opportunistic infections which need further research to answer questions by experts.

Hence, this study focuses on Warmline to give consultation services for those health-cares professionals such as Physicians and Physician assistants that are working on every healthy sector of the country in getting help to manage problems encounter HIV patient cases.

3.4.1 Warmline (Telephone Consultation Services)

American International Health Alliance revealed that increased access to ARVs (antiretroviral) drugs in Ethiopia has generated a need for members of the health sector workforce to rapidly increase their knowledge on HIV/AIDS care. To achieve this, ARC along with its partners including Johns Hopkins Center for Communication Programs, and Ethiopia's National HIV/AIDS Prevention and Control Office with support from PEPFAR through the U.S. Centers for Disease Control and Prevention established FITUN Warmline. It is a telephone call service designed to provide health-care professionals across Ethiopia with accurate and up-to-date answers to their questions about HIV/AIDS case management and treatment.

The Warmline provides free clinical advice on managing HIV/AIDS to clinicians with a wide range of experience (Ronald et al., 2003). Managing HIV/AIDS patients' cases such as caring for multiple patients with antiretroviral resistance, adverse events associated with ARV, drug interaction, management of opportunistic infections, and primary care of persons with HIV/AIDS in both available and limited access expert consultation. Besides, Chang et al (2008) explained that the Warmline helps care-givers on prevention effort like preventions of mother to child transmission, occupational exposure and post exposure prophylaxis and also how to treat opportunistic infection that is caused due to HIV/AIDS. In general, the Warmline addressed important clinical issues, including the need for urgent medical attention, medication side effects,

and general follow-up needs. Most clinical staff felt that the Warmline made their jobs easier and improved the health of patients.

However, oneWorld.net (2009) found that the low ratio of experienced HIV-care providers per infected patient is not proportional to address problems come from all regions particularly in remote areas of the country. Similarly, despite all health-care workers play an integral role in providing quality care concerning HIV related patient cases, many do not have the specialized knowledge and skills necessary to manage complex HIV treatment regimens and its adverse event.

3.4.2 HIV/AIDS Treatment as Prevention

Treatment as prevention is a term increasingly used to describe HIV prevention methods that use antiretroviral treatment to reduce the chance of HIV transmission (Chang et al, 2008). Such kind of prevention methods are used to reduce the risk of HIV from one person to another for example from an HIV positive pregnant woman to her unborn baby. It is also used to prevent HIV infection from being established in someone who has recently been exposed to the virus - like health-care worker who has received a needle stick injury. Therefore, treatment as prevention already works in the case of PMTCT and PEP.

3.4.2.1 Post Exposure Prophylaxis (PEP)

It is a kind of treatment as prevention which is given when health-care workers exposed to risks like needle stick and other exposures (Chang et al, 2008). During this happening, the consultants assess risk of exposure, use of rapid and standard HIV tests, need for PEP, and PEP regimen selection, as well as counseling and follow-up testing protocols. Then, the health-care workers receive immediate PEP recommendations that are often critical after needle stick and other exposures.

3.4.2.2 Prevention of Mother to Child Transmission (PMTCT)

The strategies for PMTCT involve more than just antiretroviral treatment (ART). The first step is the prevention of infection in women of childbearing age, coupled with prevention of unintended pregnancy in HIV positive women. Other strategies to prevent the virus passing from mother to

child include safe-delivery practices and advice on infant feeding (UNICEF, 2006). Even though it seems simple in managing of PMTCT, there are cases which are not easily managed by every health worker. During such difficulties, the health-care workers call to the Warmline experts and get guideline from them and treat it accordingly. Chang et al (2008) noted that this consultation service aimed at preventing mother-to-child HIV transmission by providing advice on treating HIV-infected pregnant women and about their infants. The experts provide advice on indications and interpretations of standard and rapid HIV tests in pregnancy as well as consultation on antiretroviral use in pregnancy, labor and delivery, and the postpartum period.

3.4.3 HIV/AIDS Treatment (Antiretroviral Therapy)

Faragon (2008) stated that the advent of Highly Active Antiretroviral Therapy (HAART) has dramatically transformed the treatment of HIV infection from a fatal disease to a chronic illness, similar to other diseases like diabetes and hypertension. In addition, Luan et al (2005) also explained that antiretroviral therapy, the only effective long-term treatment strategy to date, has resulted in significant declines in mortality and morbidity of patients with HIV infection and AIDS.

ARVs directly attack HIV. This enables the immune system to continue functioning and to overcome most opportunistic infections. There are over 20 ARVs in four different classes, defined according to the method by which they attack the virus. Because a single ARV cannot suppress the virus effectively, most doctors prescribe three or more ARVs from two different classes. This is known as combination therapy, or antiretroviral therapy (ART); when several drugs are taken, it may be known as HAART (Global AIDS Programme, 2006).

According to Rudorf and Krikorian (2005) and Global AIDS Programme (2006), there are four different classes of antiretroviral therapy. These are described below.

- **Nucleoside Reverse Transcriptase Inhibitor (NRTI):** It is considered the backbone of an antiretroviral combination regimen. The NRTI agents currently available include: Zidovudine, Lamivudine (3TC), Stavudine, Didanosine, Zalcitabine, Abacavir, Emtricitabine Nucleotide Reverse Transcriptase Inhibitors (NtRTI) – Tenofovir.

- Non-nucleoside Reverse Transcriptase Inhibitors (NNRTI): Inhibit reverse transcriptase directly by binding to the enzyme and interfering with its function. Drugs such as Nevirapine (NVP) and Efavirenz (EFV) belong to this class. The second and third classes act on the reverse transcriptase enzyme.
- Protease Inhibitors (PIs): It targets viral assembly by inhibiting the activity of protease, an enzyme used by HIV to cleave nascent proteins for final assembly of new virions. Drug of this class includes Nelfinavir (NFV).
- Entry Inhibitors (or fusion inhibitors): This interferes with binding, fusion and entry of HIV-1 to the host cell by blocking one of several targets. Maraviroc and enfuvirtide are the two currently available agents in this class.

With the advent of this ARV therapy, survival and quality of life have improved significantly. ARV therapy has also dramatically decreased mother-to-child transmission rates, as well as occupational transmission. However, ARV therapy, specifically HAART, has introduced a number of complications previously unseen in pre-HAART patients (Philbrick et al, 2005). Complex interplay among adverse reactions (ranging from minor to life threatening), factors that affect adherence, and temperamental drug interactions make ARV therapy an art strongly rooted in science. Thus, the challenge is for every health-care professional, especially pharmacists, for contributions to optimize the care of these patients. Likewise, Luan et al (2005) state that “...Treatment decision-making for most diseases, including HIV/AIDS is currently both partially art and partially science due to the uncertainties, imprecision, and subjectivities involved.”

Despite advances in HIV treatment and reductions of mortality rate due to the advent of HAART, the number of PLWHA become increases as more ART users are eligible. This in turn creates workload for health worker in managing side effects of medication associated with HAART such as drug interactions, adverse drug reaction and treatment failures, and infected with opportunistic infection diseases are often complicated to manage by health-care providers.

Hence, health-care providers involved with HIV care must remain up-to-date with new information on drug interactions, side effects and cause of treatment for those HIV patients because no regimen will be effective if the patient does not take it properly. So, adherence to ARV therapy is one of the most important predictors of treatment efficacy.

3.4.3.1 Adherence to ARV Care

Adherence to ARV care is a key issue to be considered in any ART program. Adherence is taking the correct dose of medications, on schedule, and following dietary instructions. Poor adherence is linked to the development of drug resistance, higher mortality rates, lower rates of increase in CD4 cell count, lower rates of undetectable viral load, lower therapeutic success and increased hospital days (Alemayehu & Endrias, 2008).

Luan et al (2005) explained that adherence is an important factor in antiretroviral therapy. Without adequate adherence, antiretroviral drugs will not be maintained at sufficient concentrations to suppress HIV replication and lower the plasma viral load. In addition to being associated with inferior short term virological response, poor adherence accelerates development of drug resistance. In order to achieve desirable treatment result, at least 95% adherence is required. Adherence is a very complicated issue involving many factors so that before prescribing a regimen, the clinician must consider the likelihood that the patient will adhere to the dosage schedule (total number of pills taken per day and dosing frequency)(Luan et al, 2005). Moreover, successful HIV treatment requires strict adherence to antiretroviral therapy therefore interventions to improve and maintain adherence to treatment are essential. One way to help improve treatment adherence is a strong initial counseling at entry and continuous counseling at follow up visits. Whether adequate adherence or not, drug interaction, adverse drug reaction and even treatment failure associated to ARV are common to HIV/AIDS patients. Thus, managing such difficult events of HIV patients properly also help them to prolong and improve their health condition.

3.4.3.2 Drug Interaction

Everyone responds to drugs differently. The way a person responds to a drug is affected by many factors, including genetic makeup, age, body size, the use of other drugs and dietary supplements (Hussar, 2007). The effects of drug interactions are usually unwanted and sometimes harmful to life. Interactions may increase or decrease the actions of one or more drugs, resulting in side effects or failed treatment. According to Hussar (2007), drug interacts may fall on the following possible condition.

- **Drug-Drug Interaction**

Drug-drug interactions can involve prescription or nonprescription (over-the-counter) drugs. Types of drug-drug interactions include duplication, opposition (antagonism), and alteration of what the body does to one or both drugs.

- **Drug-Nutrient Interaction**

Nutrients include food, beverages (including alcohol), and dietary supplements. Consumption of these substances may alter the effects of drugs the person takes.

- **Drug-Disease Interaction**

Sometimes, drugs that are helpful in one disease are harmful in another disorder. Drug-disease interactions are common among elders who tend to have more diseases even though it can occur in any age group. Infants and older people particularly have problems with drug response. Their liver and kidneys function less effectively, so drugs that are broken down by the liver or excreted by the kidney tend to accumulate, thus potentially causing problems.

3.4.3.3 Adverse Drug Reactions /Managing Side Effects

Adverse drug reactions are common among HIV infected patients because of the large number of medications they require and the underlying altered immune status. In the UK a major study of hospital patients found that up to 6.5% of admissions were due to ADRs, three-quarters of which were judged preventable. Of those patients admitted with an ADR, 2.3% of died (Blenkinsopp et al, 2007) citing (Pirmohamed et al, 2004). On the other hand, research has been conducted in

Ethiopia to assess the magnitude of ADR on the HIV patient who has taken anti-HIV medication. Assegid (2007) explained that the frequency of ADRs among patients who were on ARV drugs was found out to be 24% of the total population under taken for the study.

Therefore, adverse events following medical therapies are common. Identifying true drug adverse events, however, is challenging. Complicating factors of drug reactions include the numerous clinical symptoms and multiple mechanisms of drug-host interaction, are poorly understood (Riedl and Casills, 2003). Differentiating between complicating consequences of HIV infection and toxicities of drugs used in the management of HIV infection is not easy. However, the experience gained with combination antiretroviral (ARV) drugs has led to the recognition of several distinct adverse drug events.

Serious and life-threatening adverse events associated with HAART are common and more likely to occur as AIDS-defining events. Such adverse event should be managed and treated properly so as to improve the health conditions of the patients (HAPCO&MOH, 2007).

3.4.3.4 Treating an Adverse Drug Reaction

Several factors will be considered in treating adverse reactions, such as comorbid conditions, the patient's other current medications, the availability of alternative regimens, and the patient's history of medication, stage of HIV, co-administration of other drugs, co-existing infection or opportunistic infections and chronic illness (Marfatia& Smita, 2005; AETC, 2007). In addition, the patient's report of severity can be investigated in both the clinical and laboratory interpretation because some patients may report overemphasizes symptoms, whereas others underemphasize symptoms). These are important input parameter that must be considered when determining the drug adverse reactions associated with ARV.

3.4.3.5 Opportunistic Infections (OIs) Diseases Associated with ARV

Opportunistic infections (OIs) diseases associated with ARV are one of the challenges in HIV patients. HIV causes progressive depletion of the CD4 T cells, resulting in conditions known as opportunistic infections or malignancies (HAPCO & MOH, 2007). Similarly, AVERT (2010) an international AIDS charity notice that people with advanced HIV infection are vulnerable to

infections and malignancies that are called 'opportunistic infections' because they take advantage of the opportunity offered by a weakened immune system.

Therefore, prophylaxis and early treatment of other infections were done to improve the quality and length of life of people living with HIV, even before the advent of HAART. However, opportunistic infections continue to cause morbidity and mortality in HIV/AIDS patients even after ART. Due to the fact that some patients do not have a sustained response to antiretroviral agents for multiple reasons, such as poor adherence, drug toxicities, drug interactions, or initial acquisition of a drug-resistant (HAPCO & MOH, 2007).

CHAPTER FOUR

RESEARCH DESIGN AND METHODOLOGY

4.1 Introduction

This chapter covers the research design and methodology employed for the study. It mainly dealt with collecting the required knowledge for the research and how that knowledge is collected from primary and secondary sources. The chapter also dealt with the approach used and the conditions under which the various stages of investigations were carried out so as to make experiments and to achieve the required results.

4.2 Study Area

Before the research activities carried out, it was necessary to define the problem for the research. After some preliminary investigation using participatory observation, interview and detail discussion with senior experts apart from reviewing of relevant cases, it was decided to focus on Telephone Call Clinician Consultation Service (Warmline).

The Warmline is staffed with three doctors, one pharmacist, two nurses and one laboratory technologist who are working on a full time basis and four other voluntaries. All full time workers are trained on ART treatment and adherence counseling which is mandatory to work in collaboration with respect to their profession. The organization is working in collaboration with a multi-dimensional partnership and often gets technical and other assistance from Central Disease Control (CDC) Ethiopia, HIV/AIDS Prevention and Control Office (HAPCO), John Hopkins University and World Health Organization (WHO).

Thus, the Warmline was taken as the research area since the physician in the Warmline confront with many HIV case problems in providing support to health-care workers in the country. In addition, since the communication is through telephone call, cancellation of call is a major problem that encounter to health professionals in giving appropriate therapy to their clients. On the other hand, the highly qualified experts who are trained in the country or abroad with regard

to HIV/AIDS are available so that their experience is utmost important to duplicate using KBS so as to use by less qualified professional to manage HIV/AIDS cases in all region of the country.

4.3 Study Subjects

The study subjects for this research were person living with HIV/AIDS (PLWHA) started on antiretroviral treatment when they encountered problems with antiretroviral (ARV) drugs.

4.4 Knowledge Source

Knowledge acquisition for the study relies on many sources. Both primary and secondary source of knowledge were obtained for the purpose of this study. As primary sources, various experts in the Warmline including medical doctors, pharmacists, laboratory technologists, nurses, public health specialists, and a psychiatrist were interviewed. Besides, relevant literature from all possible sources and formats, including journal articles, guideline for HIV case management and antiretroviral therapy, HIV related books, thesis, the Internet and related websites were reviewed as secondary sources.

4.5 Knowledge Acquisition procedures

The knowledge acquisition procedures for this study were carried out mainly through interview and discussion with individual experts. Among the various available interview techniques, semi-structured interview method was constructed and employed for the study. Since it combines the features of both unstructured and structured techniques, it is the preferred style of interview as it helps to focus the experts on the key questions and help avoid them giving unnecessary information. It is also flexible and suitable to ask subsequent questions than structured interview. Thus, an in-depth semi-structured interview was conducted with senior experts by asking questions about the methods how they advise health-care workers when they treat HIV patients those who affected by adverse events of HIV cases, the problems usually encounter, their experience in solving these problems, the kind of cases usually requested by health workers, the different opportunistic infection disease and treatment mechanisms as illustrated (Appendix I).

Some experts were usually busy and interviews held in the expert's work environment were likely to be interrupted. To fill this gap and maximizing access to the expert knowledge and minimize interruptions, experts were hold meetings away from the expert's workplace such as meetings after work hours and on weekends.

In addition, recorded HIV cases were collected from the Warmline. These recorded cases contain information on patient's details, the WHO clinical staging of the disease at the start of ART, duration of treatment, drug details, and nature of the adverse drug reactions, severity, solution, and result of investigations performed were collected by consulting the experts for those cases and terminology that need more clarity.

4.6 Sampling Techniques

To acquire domain knowledge for the research, five experts were selected using purposive sampling techniques. According to Bless and Higson-Smith (2000), cited in Tan (2008) purposive sampling is used in special situations in which a researcher selects unique cases that are especially informative for an in-depth investigation. From the five experts, two were medical doctors with MD degree having more than two years of experience. One of them was nurse with BSc degree having 2 years of experience. The remaining two were laboratory technologist and a pharmacist with BSc degree with more than two years of experience. Acquiring knowledge from five domain experts from eleven available experts in the area was sufficient for the purpose of this research. To maximize the acquisition process experts were selected based on their educational qualifications, year of experience, and their immediate job positions in the domain area in order to minimize the constraints of the knowledge acquisition tasks.

4.7 Data Preparation for Analysis

This was a step where the collected cases were arranged into a form that will be suitable for the selected CBR tools. As a result, missing values and noisy characters in the recorded cases were removed during the preparation of case features for building the CBR case-base. The reason for avoiding missing values and noisy characters, are due to the fact that unknown values may lead to uncertain consequences. Thus, important case features were derived in order to build the case-base in the development of the CBR system.

4.8 CBR Design and Implementation Tool

4.8.1 Design and building the CBR model

After clearing and transforming the collected cases and derives appropriate case features in designing the CBR case-base, the next task will be building the CBR model using the cases. In order to get the required information for the research and comments for the different stages of the experimentation and evaluation, a total of fifty-one recorded cases were collected from AIDS resource center of Ethiopia. The cases have been used for training, testing and validation of the model. Efforts were made to make the cases as representative as possible. In order to construct the CBR system, the cases were organized into training and test dataset and leave-one-out cross-validation testing proportion was applied. Leave-one-out cross-validation is simply n -fold cross-validation, where n is the number of instances in the dataset. Each instance in turn is left out, and the learning method is trained on all the remaining instances (Witten & Frank, 2005).

According to Witten & Frank (2005), leave-one-out cross-validation is attractive for two main reasons. First, the more data used for training in each case, presumably increases the chance of that the classifier is an accurate one. Second, the procedure is deterministic; no random sampling is involved. Despite the high computational cost, it offers a chance of squeezing the maximum out of a small dataset and obtaining as accurate an estimated as possible. So as to fully utilize the available cases, the researcher has used all the adverse drug reaction cases collected to construct the case-base, and each case was also used as a new case for testing the system. The first test case was used as the description of cases for retrieving similar cases from the 50 other cases. As a result, the researcher could make 51 retrievals with 51 different new testing cases and, during the tests, the case-base always held 50 cases.

Shi and Yeh (1999) designed a research using case-based reasoning on the integration of case-based system and GIS (geographical information system) in development control. To build the case-base for that research, a total of thirty-nine available planning application cases were used. Using the principle of leave-one-out crosses validation, the available cases divided into thirty-nine cases as training dataset and thirty-nine cases for testing datasets. Using this size of dataset, Shi and Yeh explained that the research has achieved its objectives since the system supports the users in finding useful cases efficiently. Moreover, Baig (2008) conducted a master thesis that

helped in supporting for diagnosing stroke patients using case-based reason. In building the case-base, forty-five stroke patient cases were used and fifteen cases for testing the system and the remaining thirty for training. This showed that constructing case-base using fifty-one adverse drug reaction cases reasonable for this research. A prototyping approach was used to design the CBR system so that the system has been tested first for its feasibility before taking on the complete task of designing and implementing the system.

4.8.2 CBR Implementation Tool

The selection of development tool for CBR system must satisfy certain criteria in order to save time and effort in fulfilling its objective. It also takes into account the selected tool is fully functional to support and implement the knowledge. For the study, JCOLIBRI was selected as prototyping implementation tool. JCOLIBRI(Java Class Ontology Libraries Integration for Building Reasoning Infrastructure) is an object-oriented framework in Java for building CBR systems that is an evolution of previous work on knowledge intensive CBR (Stoyano, Govedarova & Popchev, 2005). It is a technological evolution of COLIBRI (Cases and Ontology Libraries Integration for Building Reasoning Infrastructures). The choice of JCOLIBRI is due to the following basic reasons:

- JCOLIBRI represents cases in a very simple way and has also various functionalities to represent the acquired and structured knowledge.
- It offers an easier development process that is based on the reuse of past designs and implementations.
- Framework is supported by different data types which define any simple case
- The tool supports different knowledge representation techniques.
- It supports good interface facilities with external programs and systems.
- It is also accessibility and ease of use.

4.9 Testing and Evaluation

The developed CBR system was tested and evaluated to ensure the software performance is meeting towards established objectives. The evaluation process was more concerned with system validation and user acceptance. Validation efforts determine if the system performs the intended task satisfactorily. User acceptance efforts are concerned with issues impacting how well the system addresses the needs of the user (Tan, 2008).

The validity of the knowledge-based system was tested using the test dataset to measure the performance the system. The developed system was tested separately based on the module. Immediately following the development of the prototype system, an informal test to evaluate the completeness of knowledge-base, is conducted. This test provides the early verification of the system. In the next, the system was tested against real problems from its domain. The objectives are to determine the effectiveness of the system in solving the problems that arises from HIV cases and to detect uncover system deficiencies. Past cases were used for testing. During this time, there is a certain incorrect results provided by CBR system. These incorrect results was discussed and reasoned out with domain expert. Mistakes were corrected immediately by modifying the case-base. Finally, the prototype has been tested and decision of human experts on previous cases was compared with the system recommendations in order to proof its applicability in HIV/AIDS.

Having developed the prototype, the performance of the system was evaluated by taking different criteria to measure performance of the system. One criterion is users' test acceptance. The researcher uses questionnaires to collect users' feedback to see the system acceptance by users. On the other hand, statistical analysis using the standard precision and recall has been used to evaluate the retrieval performance of the prototype system.

CHAPTER FIVE

KNOWLEDGE ACQUISITION AND CONCEPT MODELLING

5.1 Knowledge Acquisition

Jones (1989) explained knowledge acquisition as the process of extracting, structuring and organizing knowledge from one source, usually human experts to a computer program. The process of knowledge acquisition typically involves a knowledge engineer gaining “both tacit and explicit knowledge “from human expert in the subject domain as well as relevant documents (Miller, 2009). It is the bottleneck of artificial intelligence. Knowledge acquisition in general includes the elicitation, collection, analysis, modeling and validation of knowledge for effective implementation of knowledge-base system. Knowledge elicitation and structuring are the two most sub activities of knowledge acquisition processes which are carried out by knowledge engineer in order to build knowledge-base system (Jones, 1989).

The knowledge acquisition process for CBR is fundamentally similar. Most differences are largely terminology discrepancy. According to Miller (2009) citing Cunningham and Bonzano, (1999), knowledge acquisition process satisfies two major tasks in CBR: Problem analysis and development of the inference mechanism. Problem analysis involves transforming the knowledge acquired from the domain expert organized in the case-based data structure. On other hand, the inference mechanism is the algorithm used for similarity assessment during the case retrieval process.

Therefore, the main purpose of this chapter is to obtain the knowledge from experts and relevant documents, structuring and building the model by identifying the concepts and variables involving in managing of PLWHA when encounter problems associated with antiretroviral therapy. In this research, the knowledge acquisition process was performed through the collection of case histories, interviewing domain experts and review of related documents.

5.1.1 Knowledge Acquisition from Domain Expert

Human experts often use their knowledge and experience to solve real problems in their workplace. In such situation experts apply not only their heuristics knowledge but also they use their experience that need subjective judgment in making decision related to the particular problem. A typical example using such decision is a medical diagnosis. When the physician faced with a new patient the doctor examines the patients' current symptoms and compares with those patients that were having similar symptoms before. The treatment of those similar patients are then used and modified, if necessary, to fit with the current new patient cases. This shows that in developing a knowledge-base system, capturing of experts knowledge and the procedures how they perform their task is very important. In addition When attempting to capture and preserve knowledge, it is also essential to consider the type of knowledge to be gathered. A particular knowledge may exist in either tacit or explicit knowledge form. The most valuable knowledge is in the heads of experts (tacit knowledge). Tacit knowledge has a limited life. Due to this reason the vast amount of tacit knowledge in experts mind should be codified and digitized in order to be used and understood by non-experts. The knowledge at the core of a well developed knowledge-base system comes from human experts despite it can be developed from a range of sources such as textbooks, manuals and simulation models. Hence, tacit knowledge is acquired from human experts (doctors, pharmacist, laboratory technician, nurse) using the selected knowledge acquisition methods.

5.1.2 Knowledge Acquisition from Relevant Documents

In addition to tacit knowledge, explicit knowledge has also major contribution in developing case-based reasoning systems. These documents were obtained from various sources. So, knowledge is extracted from national guideline in the treatment of HIV/AIDS prepared for universal use in the country, relevant HIV related books, research journals, leaflets (brochures) from the library of AIDS resource Center (ARC), both publication and un publication materials such as WHO, UNAIDS, MOH and different website (to download publications by Ethiopian researchers on different HIV/AIDS area as well as researches have been done abroad the country).

5.2 Knowledge Modeling

Once cases have been collected and obtained the relevant knowledge through interview from domain experts, the next task would be modeling the knowledge. Knowledge is the subjective interpretation of information in effort to recognize the applications and approach to act upon in the mind of perceiver. As such, knowledge is hard to conceive as an absolute definition in human terms. It attaches purpose and competence to knowledge, resulting in the potential to generate action (Makhfi, 2008).

Hence, knowledge modeling involves organizing and structuring of the knowledge gathering during knowledge acquisition. It is an activity, which provides an implementation independent specification of the knowledge to be represented in the knowledge-base. Knowledge modeling packages are combinations of different knowledge or concepts into a reusable format for the purpose of preserving, improving, sharing, aggregating and processing knowledge to simulate intelligence (Makhfi, 2008). Here, the basic concepts that reveal the main activities and decisions that are made to solve cases in the domain are modeled.

To model the knowledge captured from collected HIV patients' cases, hierarchical tree structure was used. This knowledge modeling method depicted the knowledge in the hierarchical manner, where the goal is placed at the highest level of the hierarchy and factors leading to that goal or concepts are represented down the hierarchy with primary parameters at the root of the tree. The hierarchy of the tree is preferred due to its ease of use for modeling and simplicity to explain the concepts of knowledge in the problem area. In the hierarchical tree modeling, ellipses are used to represent the concepts and the arrows move from the higher level to the branch is used to connect concepts in the modeling process.

For this research, only the concepts of HIV-infected persons in relation to adverse drug reaction are modeled. Thus, the next sections illustrate the conceptual models for concepts of adverse drug reaction associated to ARV and ways of treating.

5.3 Knowledge Acquisition to Identify Case Feature

As explained in the previous chapter adverse drug reaction is a harmful, unwanted effect of a drug even it can result in death unless it can be managed properly. Since occurring of ADRs may significantly impact a patient's quality of life and drug adherence, health-care workers should be aware of common ADRs with ARV and the potential management strategies.

Concepts used in treatment of HIV patient cases when they are exposed to adverse drug reaction are presented in Table 5.1. These concepts are captured and determined by interviewing domain experts and investigating the collected patients' case history consulting with experts. The interpretation of these concepts help to model the framework required for determining patients' report of severity and to treat them accordingly.

Input parameters	Output parameters
Age of the patients	Recommendation
Sex of the patient	
Current medication	
CD4 count	
Duration since startART	
Signs and symptoms	
patient's other medication	
Co-infection and chronic illness	
Lab result other than CD4 count	

Table 5.1 Input and Output Parameters of ADR Treatment of HIV Patients.

5.3.1 Modeling Concept to Manage ADR Associated with ARV

Adverse drug reactions are common, ranging from mild to life-threatening conditions for the people who use ant-HIV medication. The mild toxicities require symptomatic therapy as they are

self limiting but these toxicities require counseling so that patients need to continue treatment. On the other hand those which cause severe and life-threatening condition involve range from substitution or modification of one or more drug to switch regimen or even to stop all the medication. However, to arrive at such decision is not as such easy. It involves many clinical trial or laboratory investigations to get the cause of the adverse event. Due to the reason that some toxicity is due to class-specific effects while others are related to individual drugs.

To manage the adverse effect on the patient, it should first be determined whether or not the problem is due to ARV or co-medication. Next to this, the effects of the drug that the patient currently used are checked. By analyzing the patients' complaint severity report, assess the degree of toxicity using ACTG/PACTG adverse event grading system. Finally, they decide whether the adverse event needs to continue, modify or discontinue the medication (Fig 5.1).

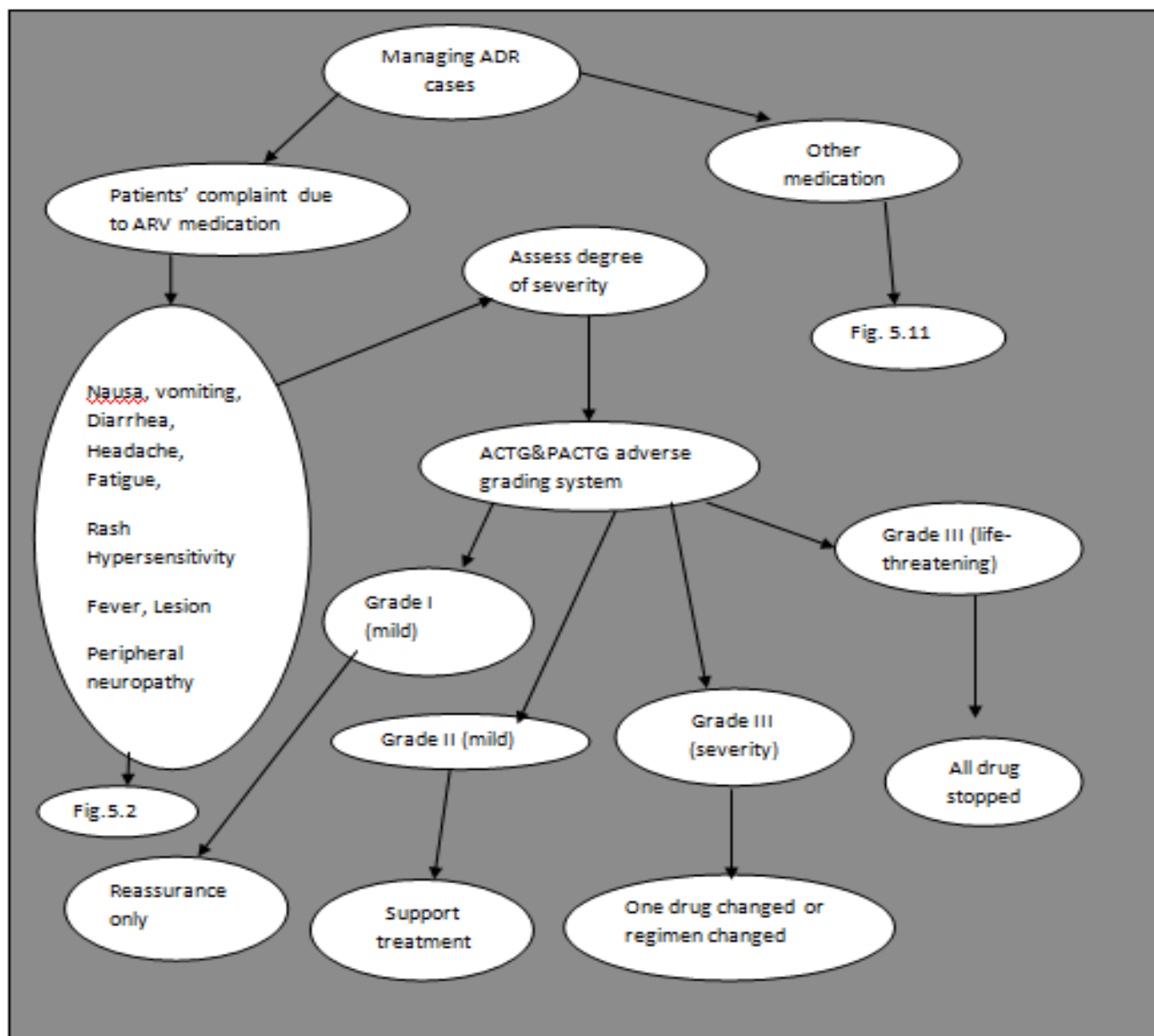

Fig 5.1 Case Concept for Determining Drug Toxicity of ADR

5.3.2. Concepts of some Signs and Symptoms of PLWHA

To manage the ADR and assess through ACTG and PACTG adverse grading system, the doctor first listens to patient's complaint. Many complaints are arisen as a result of adverse events from PLWHA who use anti-HIV medication. For example, nausea, vomiting, diarrhea, headache, allergic reaction, rash hyper sensitivity and lesions are commons. Thus, the treatment and management of such events are based on the grading level of the effects.

To illustrate the concept of diarrhea, rash hyper sensitivity and fever are shown, as examples how physicians manage when such and other complaints occur in HIV patients.

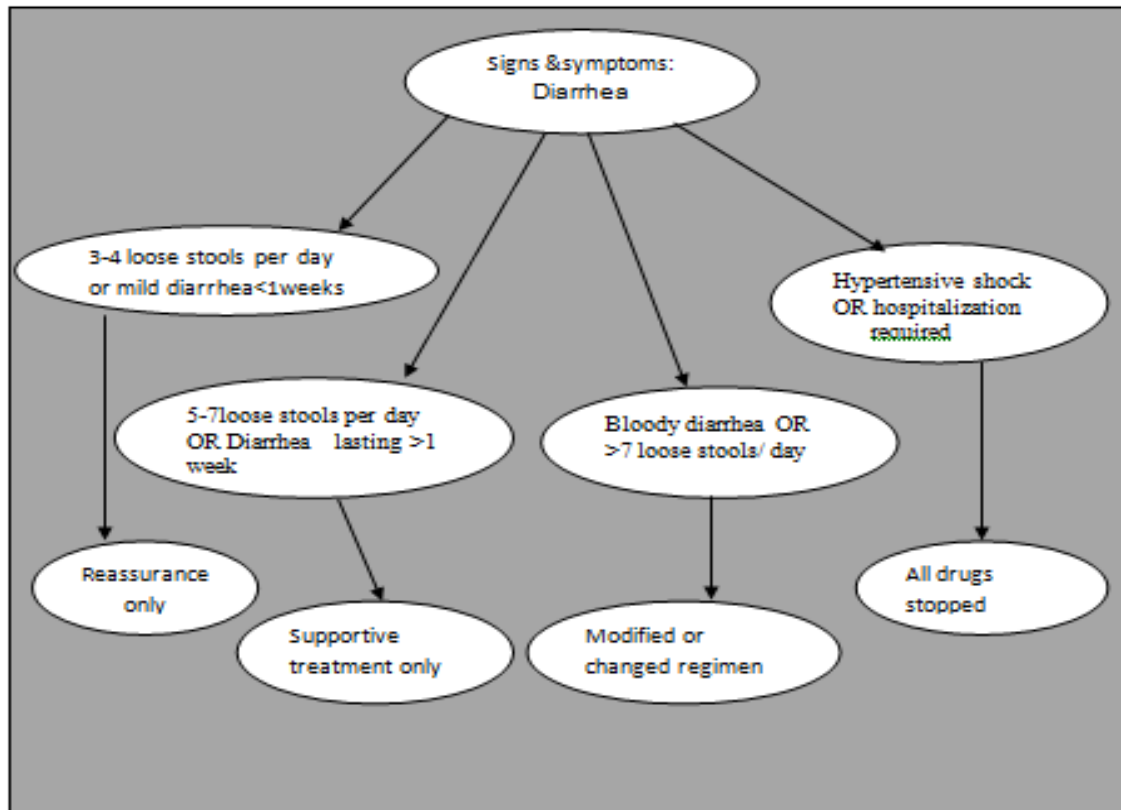

Fig. 5.2a Concepts in Managing Diarrhea

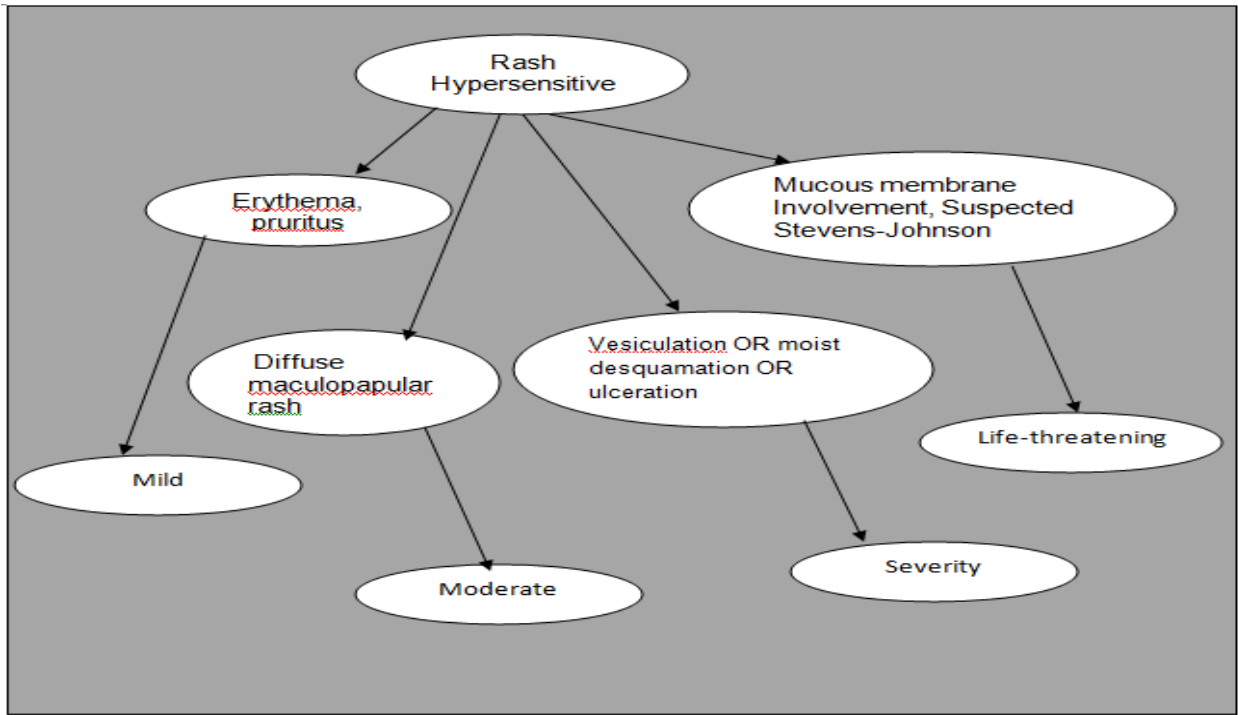

Fig.5.2 b Concepts in Managing Rash Hypersensitivity

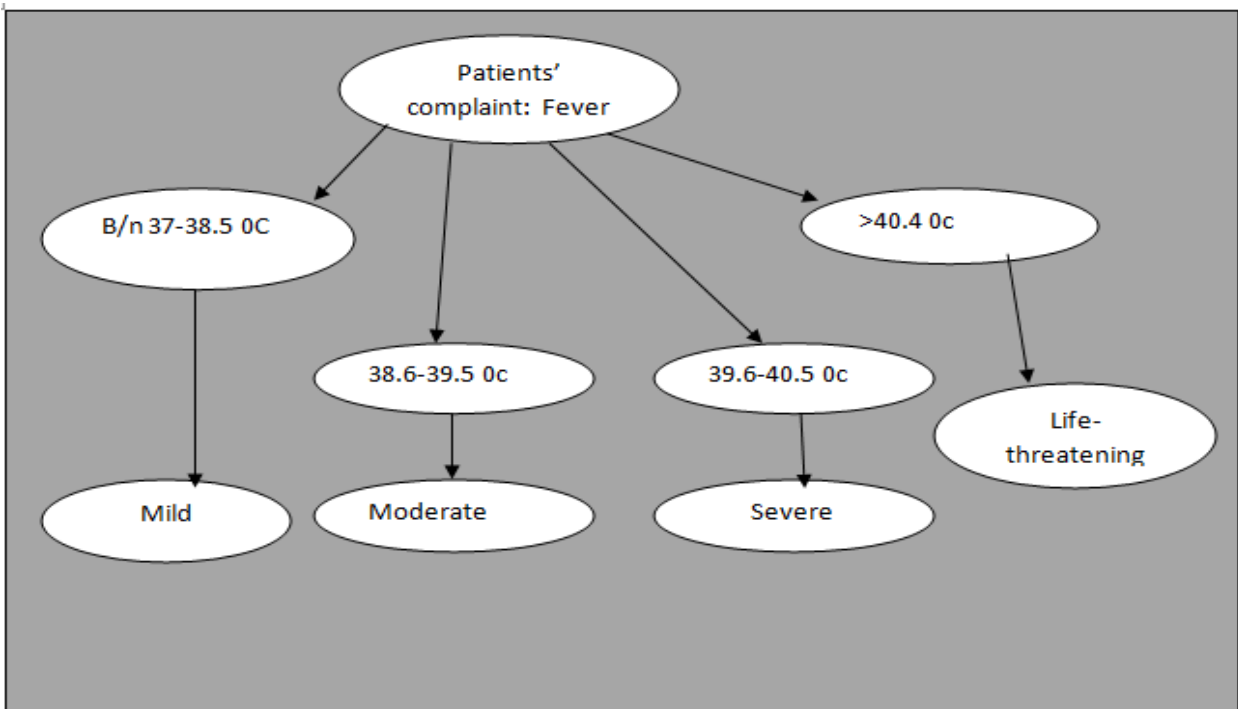

Fig. 5.2c Concepts in Managing Fever

5.3.3. Modeling the Concepts of Patients Factors

Patients' factors are the most important parameters that should be taken into account when treating patients encounter adverse drug reaction associated to antiretroviral (ARV). After examining the severity grading of the adverse event through clinical and laboratory investigation, the decision may be:

- Grade I drug toxicity (mild): - short-lived or mild discomfort; no medical intervention/therapy required.
- Grade II drug toxicity (moderate):-some assistance may be needed; no or minimal medical intervention/therapy required.
- Grade III drug toxicity (severe):- some assistance usually required; medical intervention/therapy required, hospitalization possible,
- Grade IV drug toxicity (severe life-threatening):- significant assistance required; significant medical intervention and therapy is required or rest home care.

These are not adequate in treating the adverse events to modify or change the regimen of current medication. So, in addition to this drug toxicity, patient's factor; patient's profiles (weight, age, gender of the patient) and genetic abnormalities, personalities and habits should be considered. Hence, the recommendation for modification as well as change regimen should be based on the above mentioned criteria.

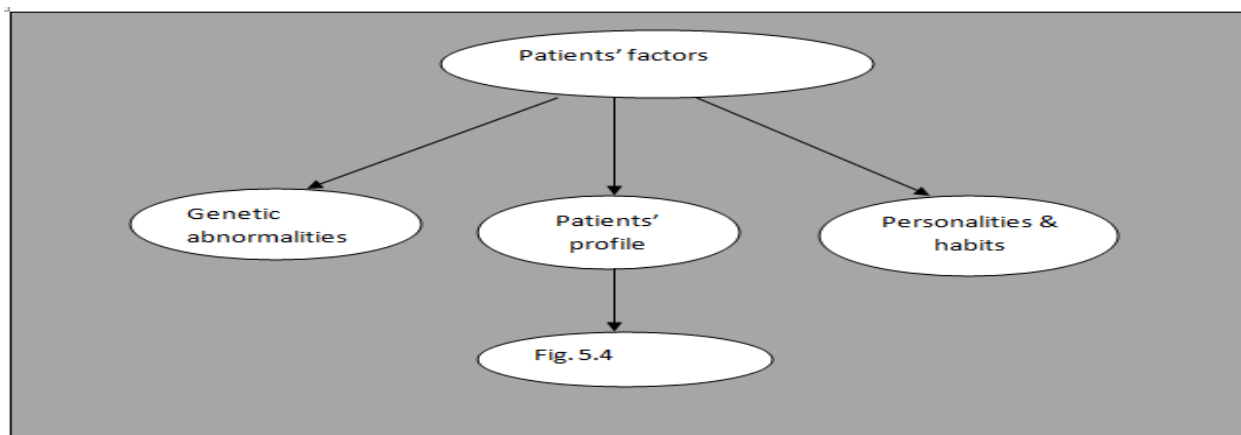

Fig. 5.3 Cases involved in Concepts of Patient Factor to Treat ADR.

5.3.3.1 Concepts of Patient's Profiles

Patients' profiles are the most determinant factors in medical process. Apart from sex, age, and weight mentioned above considering pregnancy is the most important element in treating patients.

Pregnancy: - treating of pregnant women and women of child bearing potential are not similar to men and those women who are not productive. For instance, the choice of ARV regimen for women during first trimester should never include EFV if the woman is in the first line regimen. So it is advisable to substitute with NVP. There is concern that exposure to EFV during the first trimester may lead to central nervous system birth defects during the period of organogenesis. Moreover, EFV should be avoided in women of child bearing age, unless effective contraception can be ensured. Therefore, in treating women for adverse drug reaction, to modify or change regimen accordingly, these factors should be considered (Fig 5.4).

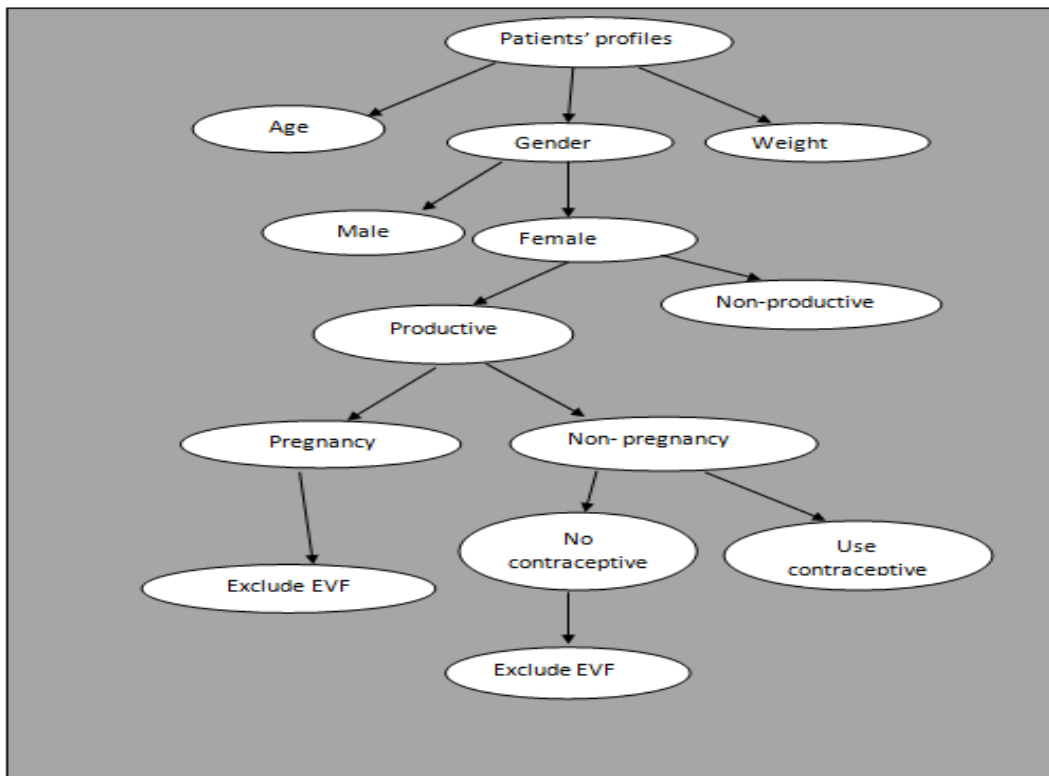

Fig.5.4 Concepts of Patients Profiles

5.3.4 Concept Modeling for Patients' Current Medication

Current medication of patients' is other important parameters in determining and managing adverse drug reactions. So, knowing the person's status of medication he/she is currently on is the major consideration in determining the causes and solutions of the adverse effects because toxicities of some drugs are due to class-specific effects while others are related to individual drugs. The current treatment conditions of the person may be either on initial regimen, one or two drug changed, regimen changed or all drugs stopped. This information helps as clue to treat the ADR accordingly (Fig.5.5).

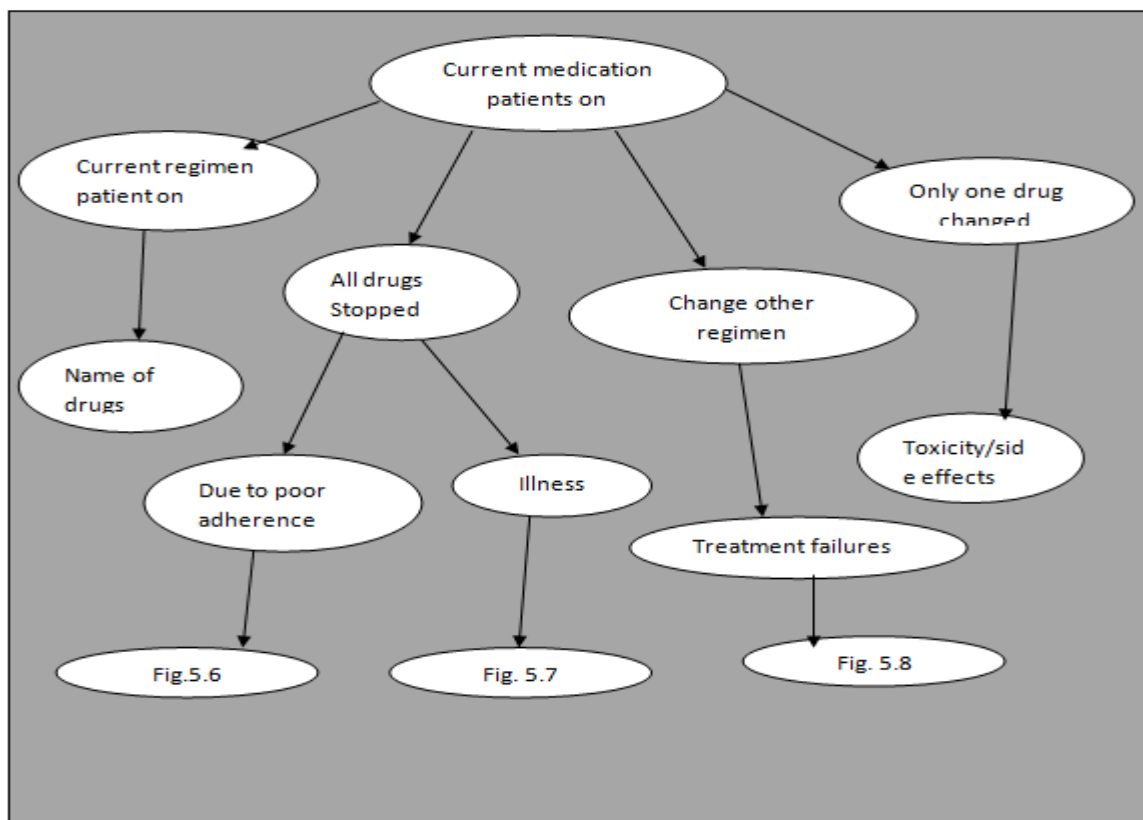

Fig.5.5 Status of the Patients and Current Medication Condition

5.3.4.1 Modeling of Concepts for Poor Adherence

Persons on HIV treatment need to take three or more types of ARVs everyday for the rest of their lives. If drugs are not taken routinely, at around the same time every day, HIV may become resistant to the therapy or may cause adverse events. In addition, there are a number of factors that commonly cause adherence problems like incorrect drug or drug combination, incorrect route of administration, incorrect dose and incorrect duration of therapy. Lastly, poor adherence results adverse events on the body of the ART users.

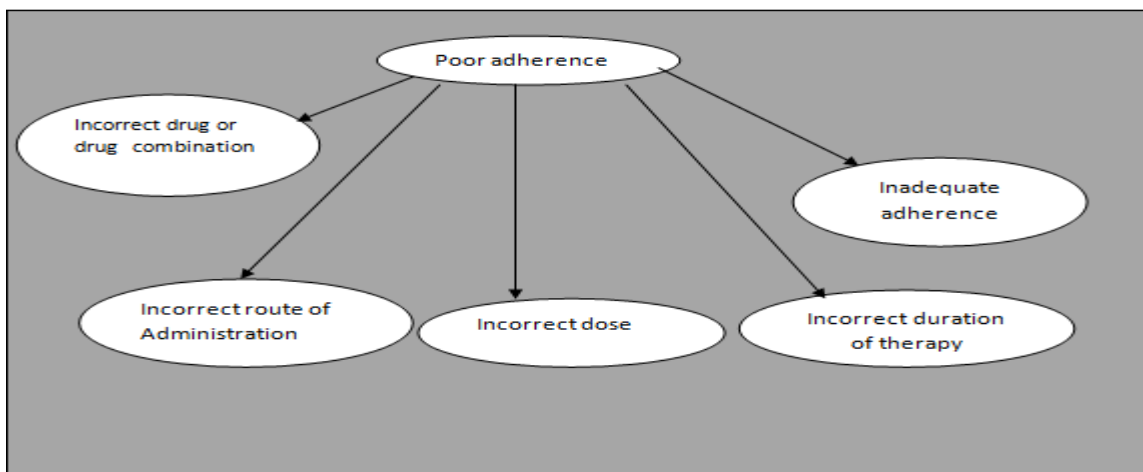

Fig. 5.6 Concepts of Poor Adherence which result in ADR

5.3.4.2 Concepts of Co-Infection and Chronic Illness

Illness other than HIV infection is also another factor that should be taken into account when treating an adverse drug reaction particularly on modification or change of regimens for the patients. For example treating of Tuberculosis (TB) depends on the patients CD4 count. If the CD4 count is greater than 200 cells/mm³, then the ARV treatment should be started after the TB treatment is completed. On the one hand, the ARV treatment waits till the intensive treatment is finished provided that the CD4 count is between 50 and 200 cells/mm³. However, the ARV drug started immediately if the CD4 count becomes below 50 cells/mm³. Moreover, the decision on how to adjust dose when the HIV patient has renal failure depends on the results of the Renal Function Test (RFT). The decision with ARV is depending on the drug toxicity grading level. Hepatic failure is another illness tested through Liver Function Test (LFT). Hence, the dose adjustment in patients largely depends on the drugs nature of the metabolism.

5.3.4.3 Managing Treatment Failures

In treating adverse drug reaction, physicians decide the treatment based on drug toxicity levels which are classified as mild, moderate, severe and life threatening. Based on clinical and lab test results, if the toxicity of drug is life threatening, then there is a need to switch regimens. The main cause to switch from first line regimen to the second line regimen is treatment failure which can be checked through clinical Failure (i.e. defined as a new or recurrent WHO stage 4 condition), CD4 Cell Failure (immunological failure) defined as fall of CD4 count to pre-therapy baseline (or below); or 50% fall from the on-treatment peak value defined as a(if known); or persistent CD4 levels below 100 cells/mm³ and virological failure (i.e. plasma viral load above 10000 copies/ml).

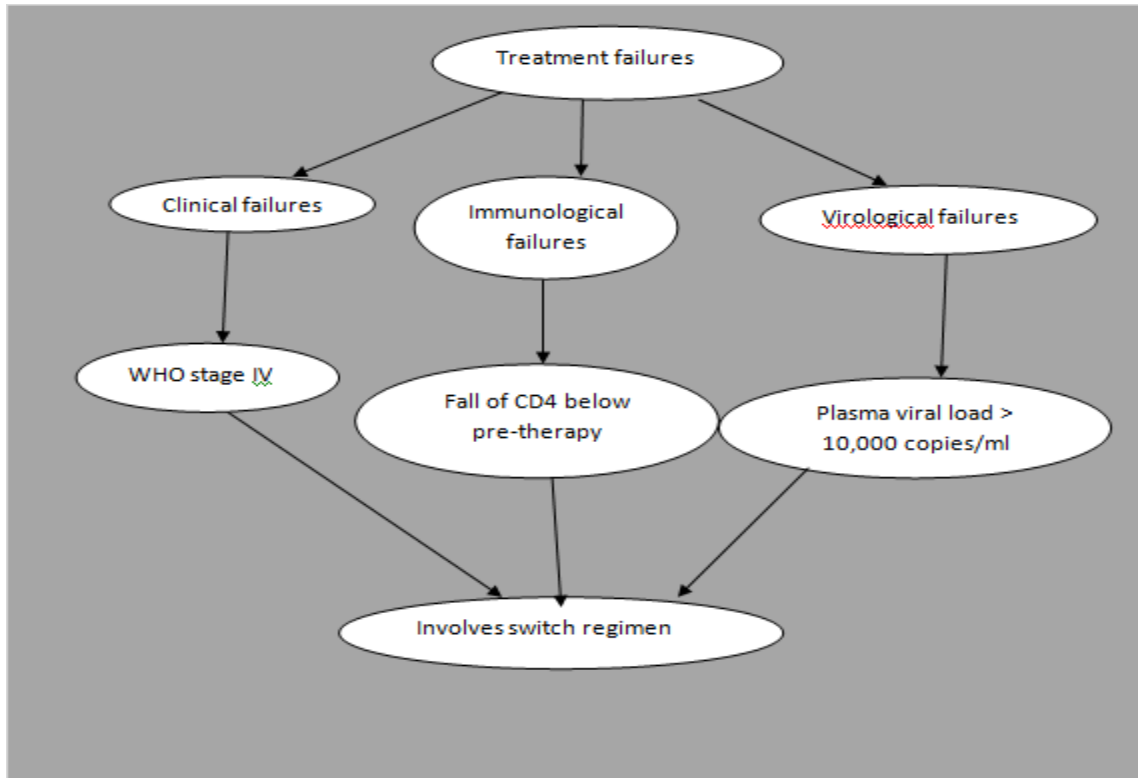

Fig. 5.7 Case of Treatment Failures and Treatment Alternatives

5.3.5. Concepts for CD4 Count and Viral Load Test for the Patients

The CD4 count is the most important parameters for initiating treatment as well as monitoring patients' progress on ART. The normal CD4 count ranges from 500-1500 cells/mm³ and values below 500 are abnormal in HIV patients. Patients with CD4 count in between 350-500 have mild immune suppression; moderate in between 200-350 and when less than 200 cells/mm³, develops severe immune suppression (Fig.5.8).

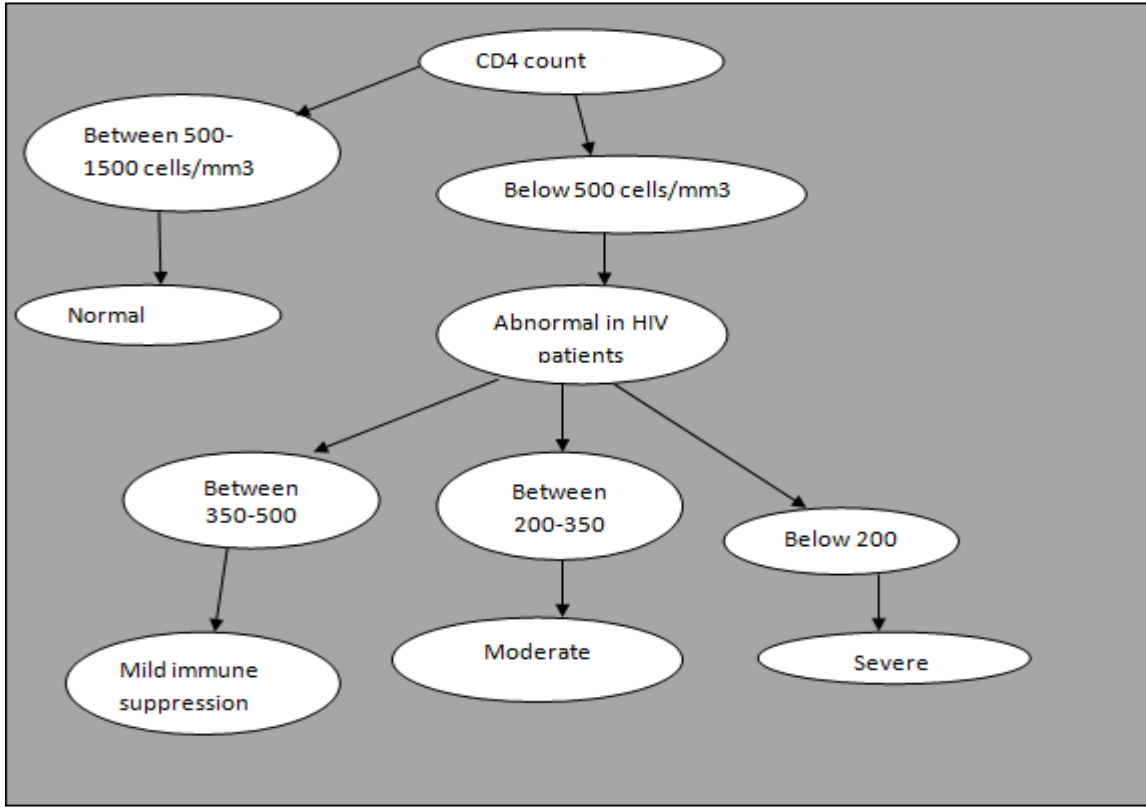

Fig. 5.8 Concepts of CD4 Count to Confirm the Clinical Status of HIV Patients

5.3.5.1 Concepts of Clinical & Laboratory States during ADR

When a person is suffering with adverse event associated with ARV medication, experts try to treat this adverse effect based on clinical or lab test results. CD4 count and viral load test are usually carried out. As result, CD4 count and viral load lab test help to know the health status progress of PLWHA by comparing against pre-therapy of CD4 count and viral load at start of ART. Hence, if the CD4 count shows increasing while decreasing in viral load (which measures the amount of HIV in an individual's blood) during lab test, then the person is on good health condition and the medication is also effective. On the one hand, if the CD4 count lab test result shows a declination while increasing viral load than baseline at start of ART, then the medication is not effective. A falling of CD4 count and a rise of viral load are a sign that HIV is progressing, and that the immune system is becoming weaker. During these event physicians involve many tasks like modifications of medication, like dose, type or change of regimens. On the other hand, there are cases when both CD4 count and viral load lab test results decline. In this

particular situation, physicians recommend patients to continue the same medication the patients currently use (Fig 5.9).

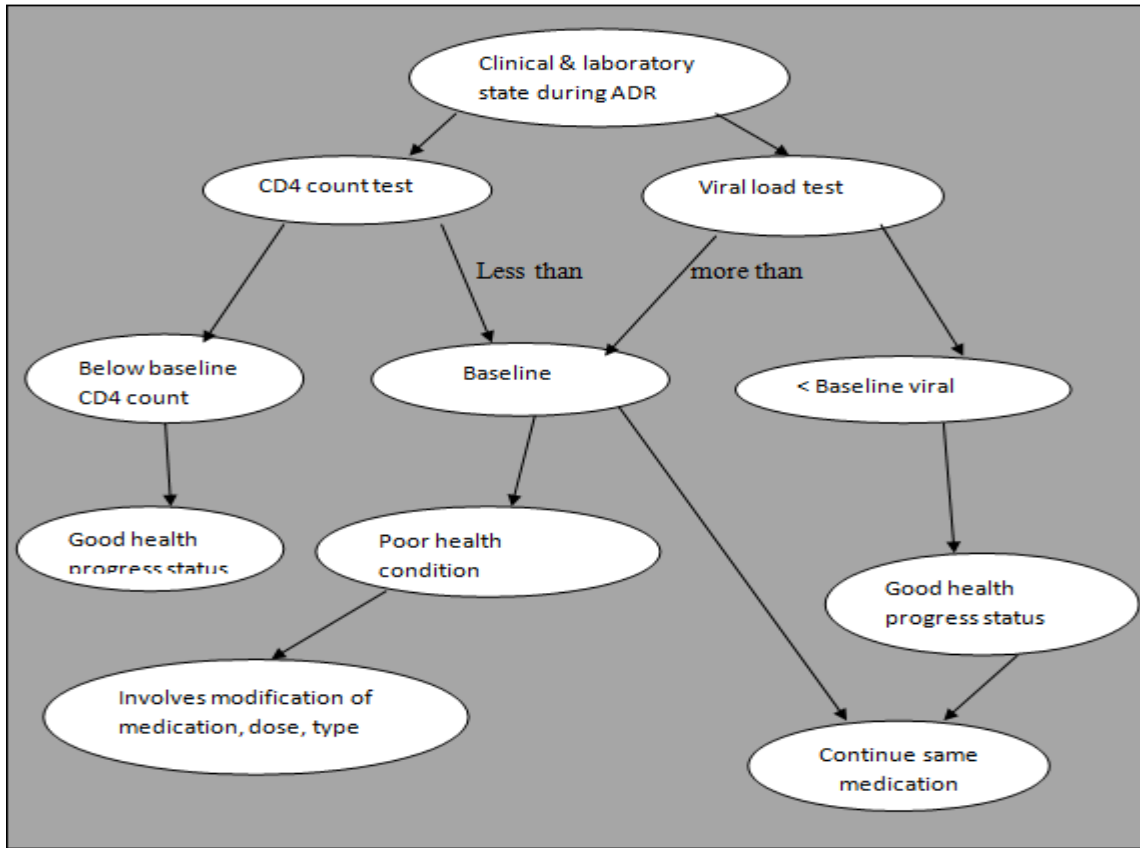
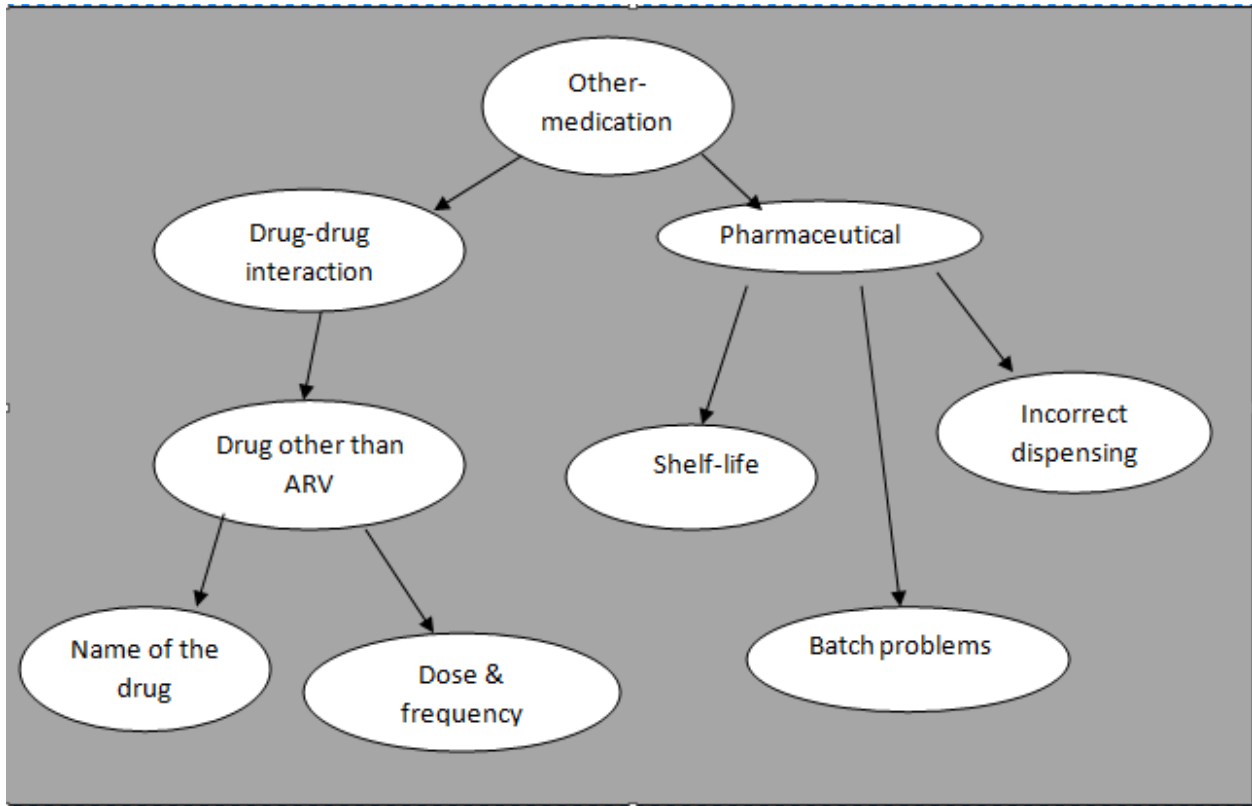

Fig5.9 Concepts for Clinical & Laboratory State during ADR

5.3.6 Other Medication

Another parameter that should be considered in managing adverse drug reactions associated to ant-HIV medication is interaction with other medication. So when the patient feels such kinds of problems, he/she should report to the nearest health-care provider. Then the physician starts the treatment by discussing with the patients and asking the type of medication he/she has taken along with ARV, including the name, dose and frequency. Finally, they observe the effects of the co-medication to the ARV so as to treat the patients (Fig 4.10).



5.10 Treating ADR when ARV Interacts with Other Medication

CHAPTER SIX

DESIGN, IMPLEMENTATION AND PERFORMANCE EVALUATION

6.1 Introduction

The design and implementation part of this section cover the discussion on developing of case-based reasoning system. The evaluation part, on the other hand, contains the result obtained when the prototype is tested using the test dataset. Hence, having the required cases and knowledge from domain experts, and relevant documents, the next task is coding the knowledge into computer using efficient knowledge representation tools. For this research, JCOLIBRI is used to design and implement the prototype and to construct the case structure. Before starting the components of design and implementation process, it is important to show the overall designing structure of the new CBR system for HIV/AIDS cases treatment and consultation services.

6.2 Designing CBR in HIV Case Knowledge-Based System

Fig.6.1 shows that the framework of CBR system for HIV/AIDS case treatment and consultation service. To develop the KBS, the knowledge engineer collects the required knowledge from domain experts and relevant documents. Hence, in the designing of CBR for HIV/AIDS case consultation service, the researcher collected relevant cases from domain experts and the required knowledge was built. Thus, building of CBR was started by collecting the previously solved cases in the Warmline that the physician advised health-care workers when they treated patients. The acquired cases needed further processing in order to define case structure and derive important attributes. Having done this, the selected attributes should be assigned weights and other important parameters.

Once the CBR system was developed, users could easily use to solve HIV/AIDS case problems. Users could interact to the system in order to retrieve best match cases from the case-base to solve problems. As users enter problem description (query) through user interface, the system searches the best matching cases from the case-base and return possible solution in ranked order to the problems described in the query. If exact matching occurred in between the query and

cases in the case-base, users can directly derive the solution or if the similarity or matching is approximate, then modification of the proposed solution is required (i.e. adaptation of solution carried out) so as to fit the current problem at hand. Lastly, the best modified solution to the problem should be stored to the case-base for future use. Thus, the CBR system updates its case-base incrementally as the system learns from this problem solving experience as presented (Fig.6.1).

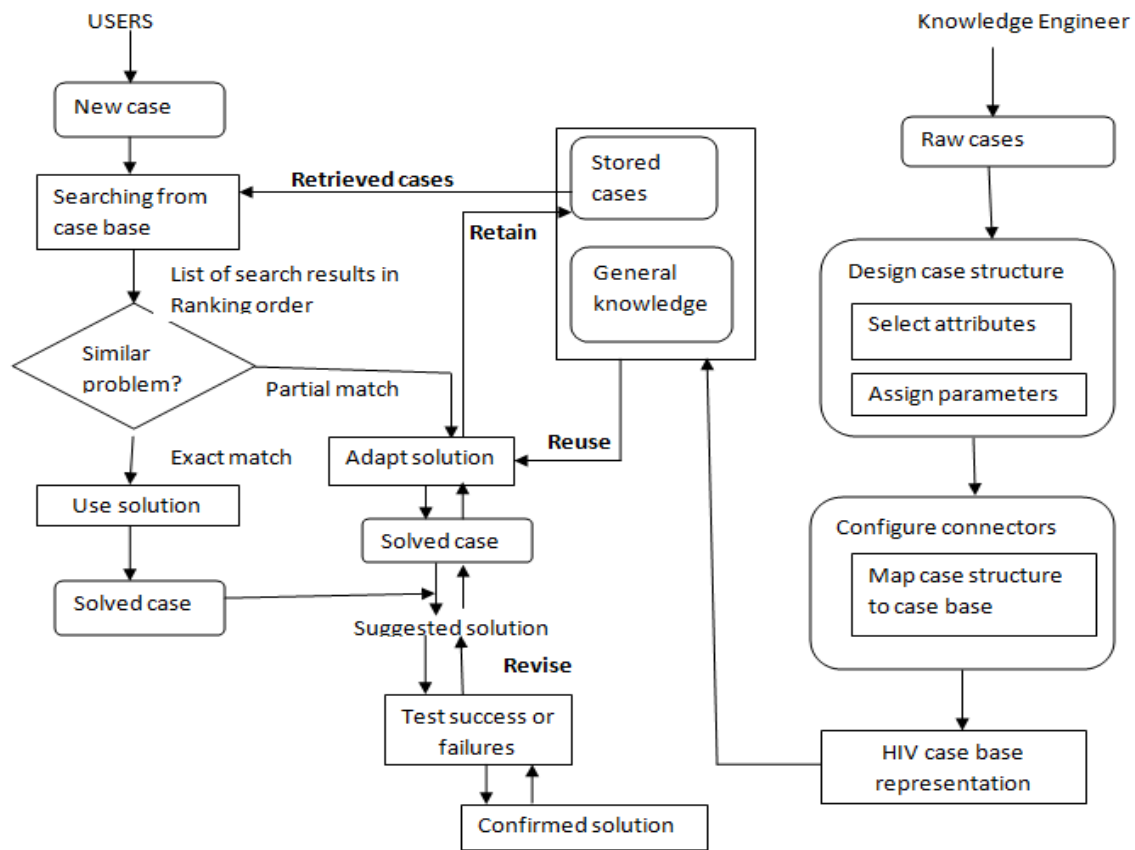

Fig.6.1 Architecture of CBR for HIV/AIDS cases treatment and consultative services

6.3 Case-Based Reasoning System for ADR Case Patients

In this section the researcher tried to use the main feature of JCOLIBRI to present the application. As Recio-Garcia and Daz-Agudo (2004) described JCOLIBRI has been constructed as core modules to offer the basic functionality for developing CBR application.

Developing a new CBR system is made by writing some Java classes that extend classes of the framework, and configuring some XML files. To make easier this process the interface layer provides several graphical tools that help users in the configuration of a new CBR system.

To launch the application the study used the graphical user interface (GUI) of the tool. JCOLIBRI can be started by clicking on exe. file of JCOLIBRI.bat and become ready to use as shown in the following main JCOLIBRI window.



Fig.6.2 Main Window JCOLIBRI

Developing a CBR system is a complex task where many decisions must be made. In this study, the development of CBR system for ADR case patient was divided into the following processes and sub processes, which are in accordance with the objectives of the research as well.

6.3.1 Building the Case-Base

As it was described in the first chapter of this study, one of the objectives was to build case-base comprising of various HIV/AIDS patients' cases to provide most useful similar cases to support physicians for managing current HIV/AIDS case problems. As a result, the researcher used a real life HIV/AIDS case medical data that physician gave advice to health-care workers, in turn, to

manage cases that involve in treating of HIV/AIDS patients. The cases are stored in the case-base as a text file after the knowledge engineer has analyzed and interpreted the case.

The case-base in the CBR system is presented as plaintext form comprising N columns representing case attributes($\{A_1, A_2, A_3, \dots, A_n\}$) and M rows representing individual cases C ($\{C_1, C_2, C_3, \dots, C_M\}$) each attributes has a sequence of possible values associated to each column attribute $A = \{V_1, V_2, V_3, \dots, V_k\}$.

The main task of the CBR system is designing the case-base containing the knowledge of the experts. To this end, the case-base consists of a set of cases that represent past knowledge of physician in advising health-care workers to treat HIV/AIDS patients those who have been affected by ADR. All missing values and noisy characters were removed during the preparation of cases to store in the case-base. Hence, the cases used in the building of the case-base were complete.

6.3.2 Case Representation

The case structure has been formulated that can easily be represented in JCOLIBRI. Designing of such case structure helps easily define the features available in the case and to measure the similarity between existing and new cases. Hence, the overall application of this research is to retrieve similar cases from the case-base that can guide future reasoning, problem solving and also transforming a solution retrieved into a solution appropriate to the current problems. The collections of cases were structured to make efficient in retrieval process. This is done through case indexing process. Indexing refers to assigning indices to cases for retrieval and comparisons of query to the case in the case-base (Lützel Schwab, S., 2007).

6.3.2.1 Selections of Case Features/Attribute Selection

After review of the selected cases and several discussions with domain experts (all of them having experience on ADR cases) from the AIDS Resource Center of Ethiopia, important features of an ADR case have been identified. Due to time constraints and complexity of the cases, the researcher focuses only those attributes which have a direct impact on decision in managing HIV/AIDS particularly ADR case patients were selected and Table 6.1, presents the

identified features. The attributes were extracted from raw cases by the researcher guided with experts in the problem domain.

Attributes name	Description
Age	Age of the patient
Sex	Sex of the patient
Current medication	Current Regimen patients on
CD4 count	To judge current clinical status of patient
Signs and symptoms	Types of ADR presented due to anti-HIV medication
Duration since initiation ART	time taken until appearance of the sings & symptoms
Co-medication	Name of other drug on use during ADRs by Patients
Co-infection & chronic illness	Other diseases developed to patients other than HIV virus
Lab results	Lab results other than CD4
Recommendations	Physician decision to the patient

Table 6.1 Selected Features for the ADR Description

Similarity Types of Case Attribute

After having identified important case features, the next task with JCOLIBRI is the definition of an appropriate similarity measure. Here, as described in Chapter two, JCOLIBRI follows the local-global approach which divides the similarity definition into a set of local similarity measures for each attribute and a global similarity measure for calculating the final similarity value. The attributes are simple and compound. Simple attributes are described by name, type, weight and local similarity function. The properties of the compound attributes, on the other hand, are the name and the global similarity function. Hence, local similarity functions are used to compute the similarity of simple attributes whereas global similarity functions are linked to compound attributes and used to get similarity of collected attributes in unique similarity values.

There are different types of local as well as global similarities. Here, the types of local similarity that we used in this application are discussed.

- Local similarities
 - **Equal:** In this local similarity, the input query and cases in the case-base are expected to be matched to get result. Otherwise, matching is failed.
 - **Interval:** In the interval similarity, exact value match is not mandatory. When it is assigned to the simple attribute and assigned interval values, JCOLIBRI remained this interval values in searching the similarity case in the case-base.

- Global similarity
 - **Average:** It is a type of global similarity that considers the average of all attribute similarity values.

Description and Weight of Case Attributes

A single case for this research purpose had nine description attributes which served to hold the descriptions of the problems and one solution attributes which could hold the solutions for the problems after having best match cases to the problems at hand. Table 6.2 presents descriptions of case attributes.

Most significance attributes			
Name	Data types	weight	Local similarity
Current-medication	string	0.9	Equal
Signs &Symptoms	string	0.9	Equal
Laboratory results	string	0.8	Equal
Significant attributes			
Co-infection & chronic illness	string	0.7	Equal
Co-medication	Boolean	0.7	Equal
CD4count	integer	0.6	Interval
Other attributes			
Duration since initiationART	integer	0.5	Interval
Age of patient	integer	0.4	Equal
Sex of patient	string	0.4	Equal
Solution Attribute			
Recommendations	string	1.0	Average

Table 6.2 Similarity and weight of Attributes for ADR Case Management

Table 6.2 above shows the description of case attributes regarding name, data types, and weight, local and global similarity. Attributes which are considered to be *most significance attributes* to the problem domain like current-medication, signs and symptoms, and laboratory results have the highest weight value 0.9, 0.9 and 0.8 respectively. On the other hand, *significant attributes* including co-infection and chronic illness, co-medication and CD4 count have medium weight values 0.7, 0.7 and 0.6 respectively as compared to *other attributes* like duration since initiation of ART, age and sex of the patient. The assignment of weights to attributes indicates that how often physician use those attributes for recommendations to treat patients with regard to the adverse of HIV/AIDS case patients. In local similarity, two attributes have interval local similarity while the rest of them have equal local similarity. All attributes except CD4 count and duration since initiations of ART which are integer type, the rest of them defined as string.

6.3.2.2 Case Structure in JCOLIBRI

One of the features of JCOLIBRI is to define case structure very easily. This is done by using the case structure window. The selected attributes are added to the description window of case structure while their properties are assigned for each selected attributes to the right side of the property window. Having done this the program generates a java code automatically and required to save the code in XML files. Most significance attributes to the problem domain are selected and set by declaring their weights and the others are also treated accordingly by the researcher guided with domain experts.

To build the case structure, the researcher used the graphical tools of JCOLIBRI (Fig 6.3). As shown below, the window is divided in two regions. The left panel displays the structure of the case as a tree, and the right panel shows the property values of the selected attributes. Once the case structure is configured and defined, it is saved with XML File.

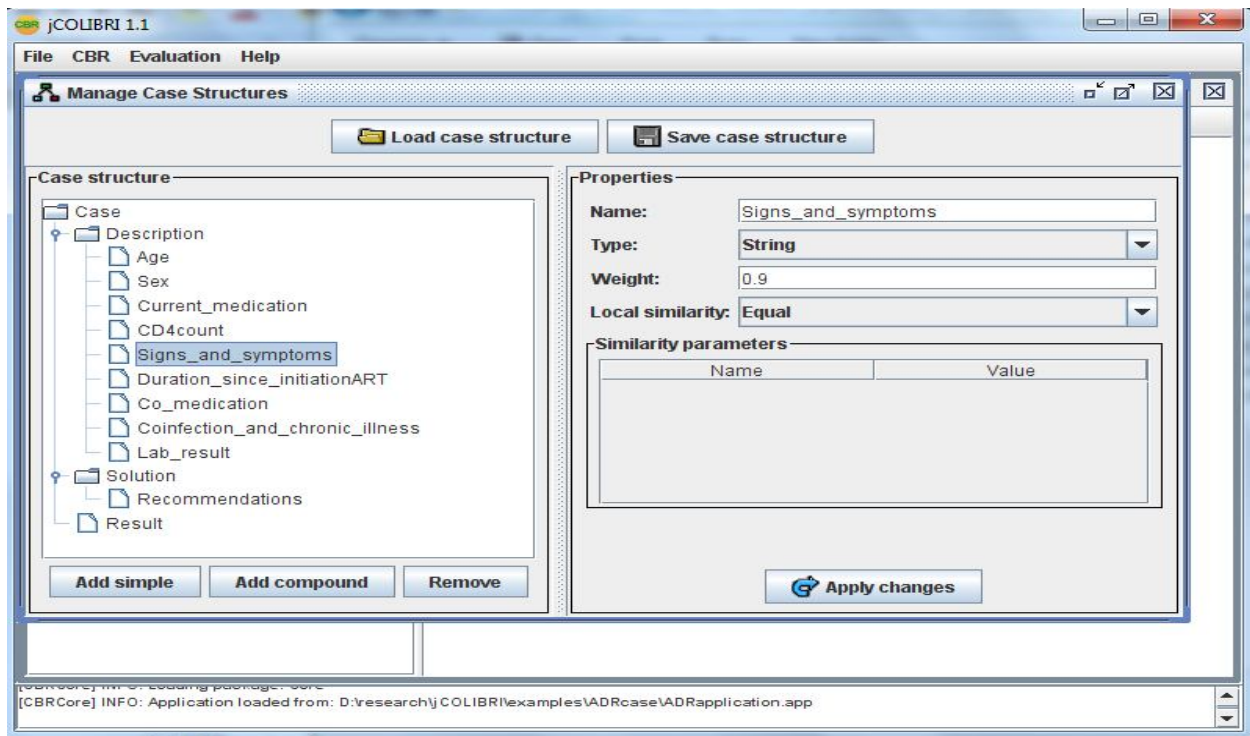

Fig. 6.3 Defining the Case Structure

6.3.3 Managing Connectors

For this research a plain text connector was used and configured. Hence, the connector helps to map the case structure to the column from the plain text files which is stored in the case-base. Connector has also saved in XML file similar to case structure. In configuring the connectors, an important task is to specify the paths of the case structure and text files. In this regard, the file path shows the path to the text file that contains the case-base and the delimiters characters that separate the values in the file as shown below in Fig.6.4.

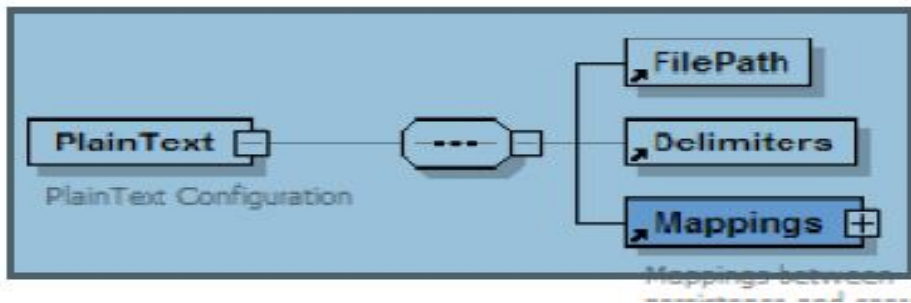

Fig. 6.4 Plain Text XML Schema

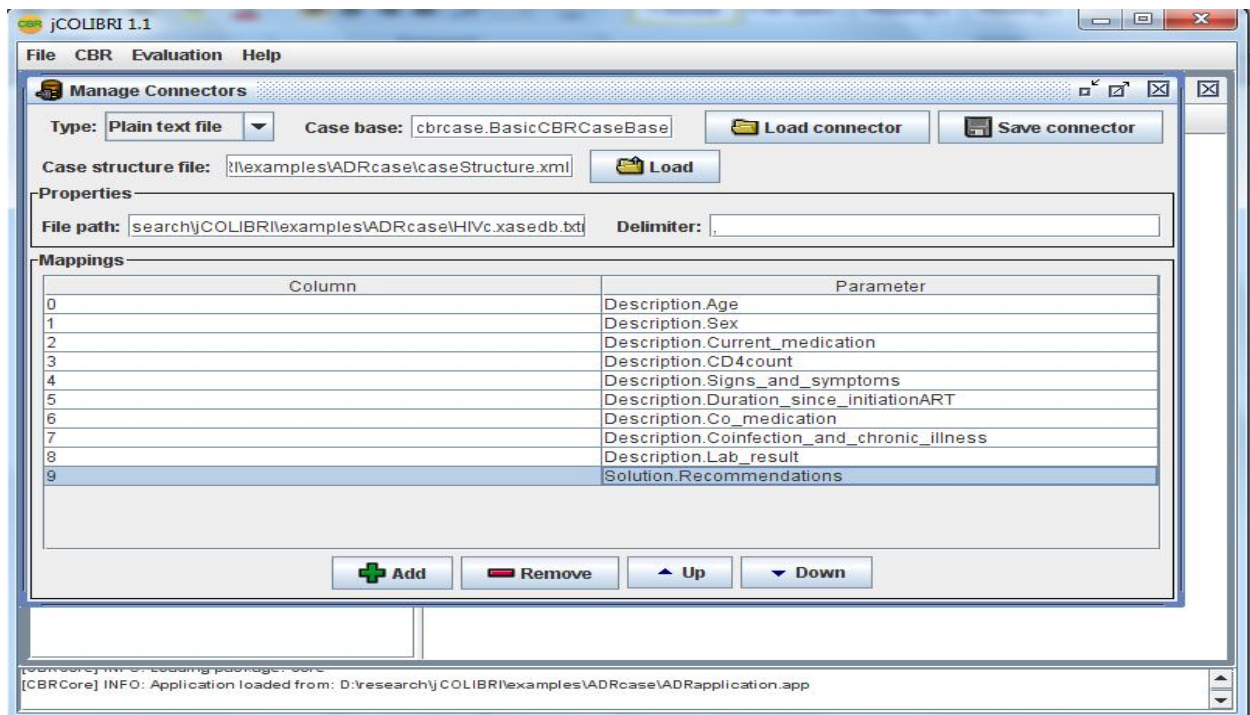

Fig. 6.5 Configuration of Connectors

6.3.4 Managing Task/ Methods

Recio-Garcia and Daz-Agudo (2004) posit that JCOLIBRI is organized in packages. These packages can perform and execute the tasks/methods decomposition process. Once defining the data structure aspect of the CBR system, for example the case structure, the connector to load and store the case-base, the next phase is configuring the more dynamic part of the CBR system: the tasks/methods. Now, further description for task and methods are treated separately in the following section.

6.3.4.1 Managing Tasks

After configuring the case structure and connectors, the next task is selecting tasks and methods for the application. Different packages are available in JCOLIBRI. The core is defined as the most important package in JCOLIBRI (Recio-Garcia & Daz-Agudo, 2004). The core is composed of CBRstate (maintain the tasks and methods configuration), CBRcontext (contain the case-base and the working-case). Hence, the core task package is presented for this research purpose. The main components of core tasks include:

- **Pre cycle:** This part of the task involves in retrieving data from case-base (i.e. used to load cases from the case-base). It is responsible for the execution of tasks before the main CBR cycle.
- **Main CBR cycle:** This main CBR cycle describes the typical cycle tasks at the highest level. Retrieve the most similar cases, reuse their knowledge to solve the problem, revise the proposed solution and lastly retain the experience. Further explanations are required for the sub tasks of each main CBR tasks.
- ✚ **Case Retrieval:** This phase of CBR model involves finding similarity between cases to the input query using the selected algorithm for case retrieval. Then the algorithm searches most similar cases from the case-base and select most similar case together with their solutions to the new problem. Similarity function can be parameterized through system configuration. The task of retrieval task includes the following sub tasks:
 - **Select working-cases task:** This sub task of retrieval task selects working-cases from case-base and stores them into current context.

- **Compute similarity tasks.** It is used to compute the similarity of cases between the previous stored cases in the case-base to the input query.
- **Select best case.** It returns best cases from case-base which has more degree of similarity to the input query. When the descriptions of a new application are input, the system calculates the similarities of previous cases in the case-base and only those cases whose similarity values are equal to a threshold set by the user in the case retrieval task will be retrieved.

Case retrieval began with a case description and end when best matching previous similar situation has been found in the case-base. Its sub process includes identifies features of the case, initial match of the query to case features of the case in case-base, searching and finally best fit set of cases which are similar to the new case will be returned.

Case Similarity, Matching and Ranking

The primary goal of the CBR system is to retrieve best similar cases by using some similarity assessment of heuristic functions. The similarity function involves in computing the similarity between the query and case, and selects the nearest similar case to the query. Thus, JCOLIBRI uses the nearest neighbor algorithms as a case retrieval technique. Nearest-neighbor algorithms used to measure the similarity between the source case and queries, and return the search results in their ranking order. For each attribute in the query and case, a local similarity function measures the similarity between two simple attribute values. Based on the matching weighted sum features from those simple attributes, the similarity score between the queries and cases for each simple attribute is assigned.

Finally, the average score of each attribute between the case and the query are computed and the result is assigned to the object (similarity between the case and query). The maximum degree of similarity among the retrieved cases is displayed according to their ranking order.

 **Reuse/Adaptation:** Once one or more cases are identified in the case-base during case-retrieval as being very similar to the new problems, the solutions are selected for this particular problem (i.e. transforming the retrieved solution to meet the requirement of a new situation). This is a reuse stage in order to generate a proposed solution for the new problem.

Although physician could learn a lot directly from similar previous cases, there are situation, where cases are not always similar to the new case at hand. During this circumstance, the physicians have to adapt this knowledge according to the particular context of the new problem. In this study, once matching cases are retrieved, the system allows physicians to adapt the suggested solutions stored in the retrieved cases to the need of the new situation. Thus, the result of adaptation could be suggestion for modifying previous solution, for instance, under new problem a new opinion may need to be added, a previous opinion may not be needed or it may need to be modified.

✚ **Revise Task:** This stage is the evaluation stage about the selected solution in reuse phase. After selecting the most similar cases from search results, the solution for the problem should be confirmed and validated before the solution is stored for future use.

✚ **Retain task:** The system stores a new case into the case-base for future use. Having confirmation in revision phase, the problem together with the obtained solution is stored. These are done when the retrieved case solution is appropriately validated and confirmed through reuse and revise steps.

- **Post cycle:** It executes after a main CBR cycle. Its main role is to close the session between case-base and graphical user interface (GUI).

6.4.4.2 Managing Methods

The method packages stores classes that resolve the task. These classes can resolve the CBR cycle using in programming or using graphical user interface (GUI). All tasks that are mentioned above should have their own methods to be assigned in order to achieve the tasks goal. The following are list of methods which has been used to solve tasks for this application.

LoadCaseBaseMethod: This method returns the whole available case from the case-base to designer. The method receives connector configuration files as parameters.

ConfigureQueryMethod: The method resolves obtain query task. By receiving case structure as input parameters, it displays a graphical user interface window so that user can request query to retrieve cases from the case-base.

SelectAllCaseMethod: It allows displaying all the available cases from the case-base to the result window.

SelectSomeCaseMethod: This method resolves to select best task by choosing the "n" most high similarity value from the returned cases. It requests the number of cases to give as input to get best match with the requested input.

NumericSimComputationalMethod: This is used to calculate similarity between the query and cases that are available in the case-base.

NumericProportionMethod: It is the sub method of reuse task which involve in computing numeric proportion between the description attributes and solution attributes.

ManualRevisionMethod: Manual revision method permits users to modify cases in the query window as they need.

In general, tasks in JCOLIBRI can be solved by several methods. So, choosing the most appropriate method for the task is the role of the knowledge engineer in the design of the CBR application. As shown in Fig.6.6, the left side shows pre cycle, CBR cycle and post cycle. When the designer selects on either of the task, the task configuration window displayed on the right side.

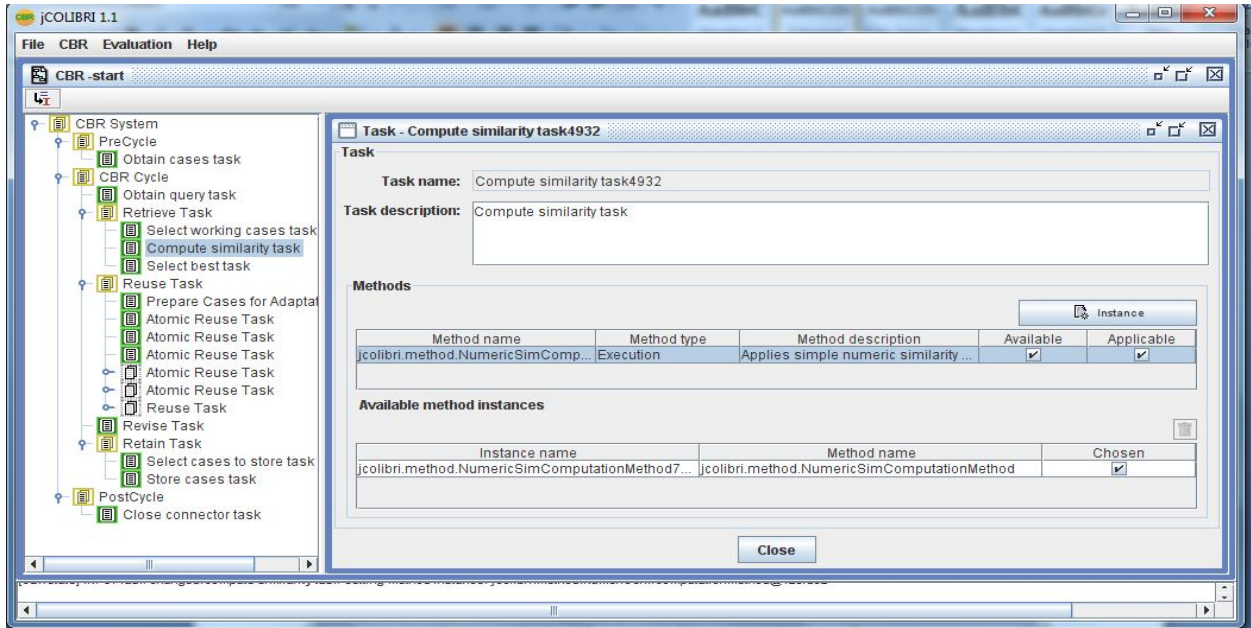

Fig 6.6 Managing Tasks/Methods

6.3.5 Deploy the CBR Application

Once defining and configuring all the steps required in JCOLIBRI, it is time to test the CBR application using the real HIV patient data (Fig.6.7).

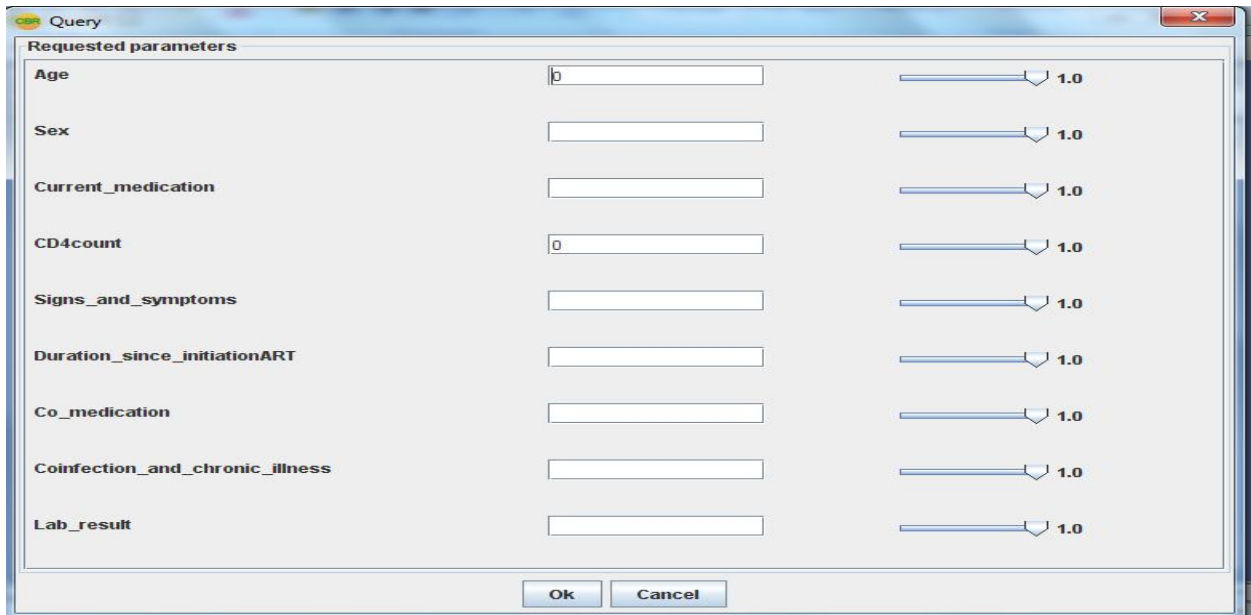

Fig. 6.7 Windows for Case Entry into the Case-Base

6.4 Testing and Performance Evaluation

6.4.1 Experimental Setting

The case-base is the core of the CBR system. Hence the construction of a case-base is the first and most important step in building a CBR system. As a result, a suitable ADR cases due to antiretroviral therapy that assured by selected physicians advised health-care workers to treat patients have been selected and stored in the case-base. The cases consist of various degrees of complexity in terms of the amount of parameters, weight, and type constructs. For this research, a total of fifty-one typical adverse drug reaction/side effect cases in Warmline were available for building and testing the system as the details presented in section 4.9.1.

6.4.2 Testing the Prototype CBR System

In this part, the validity of the knowledge-based system was tested using selected test dataset to check its validity and performance with domain experts. For purposely selected cases and assured by some human experts on previous cases were compared with the systems recommendations in order to proof its applicability in HIV/AIDS. Samples of the comparisons were given in the following sections.

Case1:

A 32 year old patient who started D4T, 3TC, NVP (1a) three months ago presented with rash seven days ago which was initially on the trunk and currently involves the back and extremities. The rash is maculopapular with no vesiculation but minimal excoriation and fever. He saw small lesions in the mouth in the frenulem area. The patient started cotrimoxazole seven days prior to ART initiation and her liver function test was SGOT18 and SGPT 27 at base line.

Q. What is the possible cause of the rash and what kind of treatment is recommended?

From the above case description the following facts are extracted manually and fed as the HIV case application query. In making a recommendation, physicians consider the following case descriptions.

The patient was male with age of 32 years.

The patient's current medication is 1a (nevarapine based regimen) and unknown CD4 count.

The patient is three months duration since initiation of ART and present rash with minimal excoriation and fever.

The patient is hepatitis illness with lab result SGOT18 and SGPT 27 and used other drugs such as cotrimoxazole.

Recommendations by physician:

Based on these facts the physician recommended that the patient has rash which involves the whole body with fever and minor mucocutaneous lesions. If all other things are ruled out, the possible cause is drug induced. As a result, nevarapine and Cotrimoxazole are the causes. Hence, it is advisable to substitute nevarapine with effaverenze and send sample for liver function test. Based on the laboratory result you can determine the toxicity level and act accordingly.

Recommendation by the prototype:

The case descriptions are fed to the prototype with jCOLIBRI1.1:

The prototype computes the similarity of the description query to the case in the case-base and selects possible solutions and the user selects the best task that most suits the case at hand. Based on this, the prototype CBR suggested the solution as to substitute nevarapine for effaverenze and send sample for liver function test.

The result showed that there is no difference between the recommendations made by the physician and the CBR prototype in this particular given case.

Case 2:

Q.I saw a female patient who has been on HAART (D4T, 3TC, NVP) for one month and CTM prophylaxis for 15 days and started to have progressive maculopapular rash all over the body with no mucosal involvement since 01 day. Her current CD4 count is 160cells/mm³ and lab tx (SGOT 468, SGPT420, ALP 523). She has no fever, no Hx of allergy. CTM was discontinued since then but to no avail. What is the possible cause? How can we manage this case?

In making a recommendation, physicians consider the following case descriptions.

The patient is female with unknown age.

The patient's current medication is D4T, 3TC, NVP and 160cells/mm³ CD4 count.

The patient is one month duration since initiation of ART and present maculopapular rash all over the body.

The patient is hepatitis illness with lab result SGOT 468, SGPT420, ALP 523 and used other drugs such as CTM cotrimoxazole.

Recommendations by the physician:

Based on these facts the physician recommended that the patient is on NVP with grade IV toxicity. So all drugs should be stopped and treat with symptomatic (antihistamine) and supportive therapy. Don't re-challenge with NVP again.

Recommendation by the prototype:

The case descriptions are fed to the prototype with jCOLIBRI1.1:

The prototype computes the similarity of the description query in the case-base and then selects possible solutions. Based on this, the system suggested the solution as the patient is on NVP with grade IV toxicity. All drugs should be stopped and treat with symptomatic (antihistamine) and supportive therapy.

The result indicated that no difference between the recommendations made by the physician and the prototype CBR in this particular given case.

Case 3:

I have got 22 years old HIV positive female patient currently on 1c for four month, her CD4 count was 397 on December and by now it dropped down to 180. She got jaundiced and referred to Adama hospital, admitted and treated there and came back to us with the referral paper which says to start her on cotrimoxazole prophylaxis. At Adama U/S done and report says liver and

spleen size 16 and 13.3 cm respectively with both normal echo pattern ,normal GB and abdominal LAP with impression of hepatomegally secondary to unknown. When she came back to us she has still a compliant of cough and persistent fever and the jaundice not resolved totally.
Q. Which regimen will be appropriate for her?

In making a recommendation, physicians extract following facts or case features.

The patient was female with age of 22 years.

The patient's current medication is 1c and 180 cells/mm³ CD4 count.

It has been four month since the patient started ART and present cough and persistent fever.

The patient was jaundiced illness with lab result liver and spleen size 16 and 13.3 cm and used other drugs such as cotrimoxazole prophylaxis.

Recommendations by the physician:

Based on these facts the physician recommended that continue the medication currently on and treat OI, test viral load then determine what is going next based on the lab results.

Recommendation by the prototype CBR:

The case descriptions are fed to the prototype with jCOLIBRI1.1:

The prototype computes the similarity of the description query in the case-base and then selects possible solutions. Based on this, the prototype CBR suggested the solution as, the patient encounter grade II toxicity, and then can continues the drugs and made close follow-up.

The recommendations made by the physician and the prototype CBR showed a slight difference. However, the solution can efficiently support the health professional with useful information despite the solution showed a partial matching to the case at hand.

Case 4:

I have a female client who is 35 years old. She has started ART two years ago and her baseline CD4 was 230. Since then she has been taking combivir/effaverinze and she is adherent to the treatment. We have been assessing her CD4 every 6 month but the value remains the same as the base line. My question is what is this cause and what should we do? Since the time she started

ART, she has lost 1kg.and we couldn't do her viral load test. In making a recommendation, physicians collect the following case descriptions from the given case.

The patient was female with age 35 years old.

The patient's current medication is combivir/effaverinze and 230 cells/mm³ CD4 count.

It has been two years since the patient started ART and the problem was no progress in clinical status.

The patient has no other illness and lab result has not been done and also no other drugs taken.

Recommendations by the physician:

Based on these facts the physician recommended that the possible reasons for this could be laboratory error, or patient is not responding to the treatment. Therefore the options are to repeat the CD4 count at different lab and collect the sample around similar time.

Recommendation by the prototype CBR:

The case descriptions are fed to the prototype with jCOLIBRI1.1:

The prototype couldn't retrieve similar cases in the case-base for the problem at hand. This shows that the input query did not match any case in the case-base.

The recommendation made by the physician and the system is not the same. That means the system couldn't retrieve similar previously solved cases which could match to the current problem in the case-base. This showed that there is no or less coverage of similar cases for this particular case in the case-base. However, this can be improved by increasing the coverage of representative cases.

For every run using the test dataset, the same procedures were applied for the remaining test cases. Thus, the prototype was tested and verified by comparing the solution attained by prototype with previously recommended case by human experts. In general, the test showed that among the total sample test cases, five did not match any case in the case-base. Having checked in the case-base it was ensured that there was no case in the case-base similar to these five test cases. On the one hand, most similar cases were retrieved by the system, when the input case has

attribute values the same as those cases in the case-base. It was also found that useful cases which help physician in recommendations included in partial matching cases. Of the forty-six sample test cases that have similar cases in the case-base, 27 (53.53.5%) samples have been considered as most similar cases retrieved by the system while the rest 19 (37.67%) as partial matching cases.

6.4.2.1 Case Similarity Testing

In addition to comparing the solution of cases made by the human and the prototype, an attempt was also made to know when the system performs well. To achieve this, the following experiment using case similarity testing was done. The purpose of this case similarity test was to evaluate whether the system selects the appropriate cases from the case-base. So, each test case was presented to the system individually, and the set of selected cases was evaluated against the expected selection to check the performance of the similarity measures. The following sample test cases were presented to check the performance similarity measures in the system.

Problem1: A new HIV patient with 24 years old has come to hospital and he has developed pruritis throughout his body with current medication 1a for the last five months. The patient's CD4 count during laboratory examination was 250 cells/mm³. He hasn't taken any other medications within the last two months. How could be the possible cause and how can it be managed?

Problem2: The physician needs to know the cause and solution for HIV patient with abdominal distention numbness currently on 1c since last nineteen months. He used other drug such as cotrimoxazole prophylaxis and has also anemia with laboratory result 9gm/dl.

Problem3: The doctor wants to diagnosis and prescribes HIV/AIDS case patients who have presented rash with current medication 1a and CD4 count 160 cells/mm³. His medical report showed that hepatics illness with lab result SGOT18 and SGPT27 and used other drugs such as cotrimoxazole.

Problem4: The doctor wants to know an HIV/AIDS case with ADR type rash for a 32 years old patient. The person medical history showed hepatics with laboratory results SGOT18 and SGPT27. The patient didn't have any other drugs other than ARV currently the patients on at a time of he/she comes to clinic.

Problem5: The doctor wants to know an HIV/AIDS case patient who has developed rash with current medication 1a with current CD4 count 160 cells/mm³. The patient has on drugs like cotrimoxazole at a time of he/she comes to see doctor.

Problem6: A 35 years old female HIV patient who is on combivir/nevarapin, presented blackish nail discoloration. What is the cause of this nail discoloration?

The following table shows the various new cases and the expected outcome:

Test cases	Problem descriptions	Similar selected cases
Query One	Problem1	Case1,case5,case11,case44,case17
Query Two	Problem2	Case5,case11,case1
Query Three	Problem3	Case4,case16,case40,case18,case2
Query Four	Problem4	Case40,case4,case16,case14,case34
Query Five	Problem5	Case29,case40,case4,case7,case16
Query Six	Problem6	null

Table 6.3 Performance of the Similarity Measure

After retrieving a set of cases from the case-base to the given query, the following cases are selected based on the degree of similarity for each of the test queries.

Queries	Similar selected cases	Similarity[0,1]
Query one	Case1	1.0
Query Two	Case5	1.0
Query Three	Case4	0.9
Query Four	Case40	0.55
Query Five	Case29	0.52
Query Six	null	null

Table 6.4 Evaluation of Test Case Similarity

As indicated in Table 6.4, query one and query two has similarity value 1.0, which implies that the cases has exact match similar value in the case-base while the rest did not as similarity value decreases .

The case similarity test results of this experiment showed that when the test case has attribute values the same as cases stored in case-base, the similarity become exact match as indicated in query one and two in Table 6.4. On the other hand, the similarity becomes decreases as a modification of one or more attributes of the test cases are in the case-base as presented in query three, four and five in Table 6.4. Furthermore, when a new case is entered to the system which has no similar case description value to any case in the case-base, the system couldn't retrieve any search results.

From the test, the study has achieved its main objectives due to its ability to support physician with useful cases. The limitation attribute selection and weighing techniques adapted for this study may affect some important features of the cases not to be represented fully. This will have an impact in computing similarity of the cases. Thus, adaptation system overcomes this problem.

6.4.2.2 Case Adaption Testing

The goal of this test case is to evaluate the system's capability to reuse cases from its case-base. The system selects working cases from case-base and stores the cases into current context. If there is no difference between a current and a retrieved similar case, a solution transfer is sufficient. When the previous solution is not fully satisfactory in the current problem, only few substitutions are required to fit the current situation. The adaption stage requires knowledge about how differences in problems of previous case and the current. So, it is up to the domain experts to reuse the retrieved cases to solve the new case rather than the system by itself derives solution. Hence, the adaptation phase of this research is left to users of the system by comparing specified parameters of the retrieved and current case to modify the solution in an appropriate direction.

In general, the adaptation process is successful as case feature of the previous and new case have similar or less discrepancy attributes. On the other hand, no adaptation process can be performed as the attribute values of the previous and new cases have more dissimilar or totally different from the previous cases.

The test result showed that the cases with minimum transformations or modification to the current problem are given priority over the others. The main purpose of this study is to retrieve suitable cases from case-base that fit the current HIV/AIDS case problem. The study achieves its objectives since domain experts can choose one case from the list of retrieved cases and apply or modify that case to fit the current problem.

The fundamental factors that affect the output of this research highly depended on the accuracy and completeness of cases. No conclusion could reach without the verification and comprehensiveness of input cases. Therefore, preparation of case structure and attributes selection to construct the case-base in this research required extracting from large documents. All these were carried out by researcher guided with domain experts. This was also need considering which attributes were more relevant and accredited for decision in the problems domain. This task was very complex, tedious and time consuming faced by the researcher.

Another problem faced by the researcher was that missing value and noisy characters in the corpus during the extraction of case structure and attributes. Because any missing data might lead to uncertain consequences, all those cases that had any missing data were not included in the study.

6.4.3 Evaluation of the Performance of the System

A good evaluation of a system not only considers the effectiveness of the system performance, but it may also reveal how the system can be improved. Moreover, the evaluation may also note down the various factors affecting the system's performance that can be synchronized to achieve optimum results. There are two performance measures used in this research: user acceptance test by domain experts and statistical evaluation analysis of the system.

6.4.3.1 Evaluation Using the Statistical Analysis

In order to perform statistical analysis of the results, the precision and recall measurements are calculated in order to quantify the performance of the CBR system.

Precision is the proportion of search results that are relevant to a particular query. In the context of this study, precision is defined as:

$$\text{Precision} = \frac{\text{number of relevant HIV cases retrieved}}{\text{Total number of HIV cases retrieved}}$$

Recall on the other hand, is the ability of a retrieval system to obtain all or most of the relevant documents in the collection. The relative recall value is thus defined as:

$$\text{Recall} = \frac{\text{number of relevant HIV cases retrieved}}{\text{Number of relevant HIV cases in case-base}}$$

The test dataset defined for this research was also used for evaluation purpose using precision and recall. To do this, there is a need to acquire relevant cases from the case-base for each test case selected by the researcher. As result, test cases were given to the domain experts in order to

assign possible relevant cases to each of the test queries. The following table shows sample test cases which are relevant to the respective test case query assigned by the domain experts.

Test dataset	Relevant case
Test case 36	Case14, case16,case7,case29,case30,case28,case22
Test case 37	case31,case29, case47,case12,case14,case4,case36,case40
Test case 38	Case23,case2,case16,case4,case27,case18,case15,case17,case35
Test case 39	Case21,case25,case13,case12,case29,case30
Test case 40	Case16,case14,case4,case18,case29,case30
Test case 41	Case19,case21,case3,case12,case51
Test case 42	Case33,case50,case25,case22, case32
Test case 43	Case48,case19,case24, case41,case28,case3,case12
Test case 44	Case1, Case8,case15,case16,case23,case26,case27,case35
Test case 45	Case7,case29,case16,case14,case32,case35

Table 6.5 Relevance Cases assigned by Domain Expert for Sample Test Cases

Once the relevant cases are identified for each test case by the domain experts, the next task is testing the prototype using the test case query to see the performance of the system. Thus, the recall and precision results for every run of the sample test queries are indicated in Table 6.6.

Test cases	Recall	precision
Case36	0.57	0.57
Case37	0.63	0.5
Case38	0.89	0.67
Case39	0.67	0.5
Case40	1.0	0.32
Case41	1.0	0.47
Case42	0.6	0.75
Case43	0.72	0.5
Case44	0.75	0.72
Case45	0.83	0.33

Table 6.6 Performance Measure using Recall-Precision

For every test dataset, the performance of the prototype was evaluated using precision/recall calculations. Hence, the average recall was 72% with average precision of 63%. Thus, more than an average in both recall and precision was registered for the performance of the system which shows promising results. The objectives of the research has also achieved since the main purpose of CBR is retrieval of relevant cases from case-base (i.e. recall). The experiment showed that assigning high weighted value for attributes that are more accredited in the problem domain for decision help to retrieve relevant cases to the new HIV/AIDS case problem.

The performance of the system was compared with the following previously conducted researches.

				Performance Evaluation	
Researcher	KBS	Techniques	Tool	Recall	Precision
Ethiopia (2002)	Labor law	CBR	Case-works	95.05%	82%
Yemisrach (2009)	Child criminal	CBR	JCOLIBRI	77%	46.3%

6.7 Performance Evaluation for Previous Researches

As shown in Table 6.7, performance evaluation using precision and recall are compared. Thus, the result of this research was shown reduced as compared to in both researches. Various reasons were encountered to significantly reduce for the average recall and precision result for this study. The first reason could be that high heterogeneity of cases in the case-base presented by HIV patient cases; however, in the first case she used homogenous type of cases to construct the case-base which result in high performance while nearly similar performance with the second research. During testing some cases are purposefully presented without similar other available cases in the case-base so as to see the performance of the system. These make the average value zero for precision and recall, and the result significantly has an impact on the average computation of the system. This variability nature of cases available in the case-base degrades the similarity and which has also an impact on the average. However, with the increase in the number of representative cases and recorded tasks, the CBR performance can be further improved and be more fertile in terms of case retrieval and its accuracy.

The second reason is that the cases were not in the required format or structure initially. So, manipulation of these cases into suitable to the CBR system of the case to put it into required case structure and attribute format was involved manually. This process is done by the researcher with the help of domain experts. So, lack of automatic case structure and attribute selection may lead to bias and cause to decrease the performance.

The other reason is that the case retrieval technique used for this research is the nearest neighbor retrieval algorithms that already built in JCOLIBRI. The algorithm is done by calculating the distance between two values of the attributes.

The greater the distance between a query and a stored case, the less the similarity between them. Thus, the performance of the system highly affected by giving more scores to those similarity attribute values and significantly reduces as the attribute value vary in their similarity. This can be another cause, but improved by using other case retrieval technique like induction algorithms.

6.4.3.2 User Acceptance Test

The validity of the CBR system is tested using users feedback to check its applicability in HIV/AIDS. The potential users for this CBR system were experts at the Telephone Clinician Consultation Service (Warmline) in ARC. So, to evaluate the CBR system, feedback was solicited from physician. Domain experts were selected so as to evaluate the acceptance and performance of the CBR system. The domain experts are classified into two major categories. The first category include evaluators who participate on several discussions during knowledge acquisition throughout the different phases of the research activities, whereas the second category include experts in the same problem domain but did not involve in the research development process which work at Telephone Clinician Consultation Sector. Thus, five experts from domain experts include two medical doctors, one nurse, one laboratory technologist and one pharmacist who have been considered as first group, were made to participate in this evaluation tasks. The reason for five experts in one group is due to the fact that only five experts were selected during sampling for knowledge acquisition, attribute selection or any other support providing to the researcher during the research progress. Similarly, the second group constitutes five experts since the total domain experts available are eleven in the organization. Therefore, to test user acceptance of the CBR system, test cases are given for the two groups of experts.

Each group of experts test the system using the given test queries and evaluate the search results in terms of adequacy and clarity of advising for case consultative service, ease of use, relevance of the search result to support in recommendations, relevance of the attributes describing the case, level of detail provided to new problems, fitness of the final solution to the new case at hand and speed of the system. These criteria of evaluations were adopted from Lee et al (2008) that used for user acceptance testing for evaluations of tax filing web sites in some modification within the context of this study.

For each case, experts were asked to assign values based on scale values and respective marks for each value. Hence, Poor=1, Fair=2, Good=3, Very good=4, and Excellent=5). Table 6.8 shows suggestion of domain experts who participate during knowledge acquisition and attribute selection.

Criteria of evaluation	1	2	3	4	5	Average
Adequacy and Clarity of advising			5			3
Ease of use				5		4
Relevance of the search result to support for recommendations			2	3		3.6
Relevance of the attributes describing the case			2	3		3.6
Level of detail provided to new problems			4	1		3.2
Fitness of the final solution to the new case at hand				5		4
Speed of the system			1	1	3	4.4
	Total average					3.69

Table 6.8 Performance Evaluation by Domain Experts (Group I)

As shown in Table 6.8, all the respondents those who have prior knowledge about the system rated the criterion ‘adequacy and clarity of advising’ as good. Similarly, with the same respondents the criterion ‘ease of use’ about the system rated as very good by all respondents. Likewise, 40% of the respondents the criterion ‘relevance of the search results to support recommendations’ rated as good and the remaining (60%) of them as very good. In addition, 40% of the respondents rated the criterion ‘relevance of attributes describing the case’ as good while the rest (60%) of them as very good. Moreover, 80% of the respondents rated the criterion ‘level of detail provided to new problems’ as good and the remaining (20%) as very good. Beside, all respondents rated the criterion ‘fitness of the final solution to the new case’ as very good. Lastly, 20% of the respondents rated the criterion about the ‘speed of the system’ as good, 20% of them as very good and the remaining (60%) as excellent.

Thus, based on evaluation of domain experts the overall average performance of the prototype system is 3.69, which is near very good. This shows that the system well simulate domain experts in recommending solution to problems in the area of HIV/AIDS.

On the other hand, Table 6.9 below shows the performance evaluation of the prototype by domain experts those who have no prior knowledge about the system (i.e. those experts who didn't participate in knowledge acquisition or in providing any other support to the researcher).

Criteria of evaluation	1	2	3	4	5	Average
Adequacy and clarity of advising			3	2		3.4
Ease of use			1	3	1	4
Relevance of the search result to support recommendations			1	3	1	4
Relevance of the attributes describing the case			4	1		3.2
Level of detail provided to new problems		2	3			2.6
Fitness of the final solution to the new case at hand			4	1		3.2
Speed of the system				3	2	4.4
Total average						3.54

Table 6.9 Performance Evaluation of the System by Domain Experts (Group II)

As shown in Table 6.9, 60% of the respondents who have no prior knowledge about the system rated the criterion 'adequacy and clarity of advising' as good and the rest (40%) as very good. Likewise, 20% of the same respondents rated the criterion 'ease of use' as good, 60% as very good while the rest (20%) as excellent. Similarly, 20% of the respondents rated the criterion 'relevance of the search result to support recommendations' as good, 60% as very good and the remaining (20%) as excellent. In addition, 80% of the respondents rated the criterion 'relevance of the attributes describing the case' as good while the rest (20%) as very good. Besides, using the criterion 'level of detail provided to new problems', 40% of the respondents rated as fair whereas the rest (60%) as good. Moreover, 80% of the respondents rated the criterion 'fitness of the final solution to the new case at hand' as good while the remaining (20%) as very good. Lastly, 60% of the respondents rated the criterion 'speed of the system' as very good whereas the rest (40%) as excellent.

In general, as evaluated by those experts who have no prior knowledge of the system is 3.54 which shows expert acceptance of the system more than good.

The result proves that there is little variation on CBR system performance by the two groups of domain experts. The variation seems because of the level of awareness of experts how the system works in detail as well as the familiarity and better knowledge about the attributes and case structures used in the system. Thus, domain experts (Group I) have prior knowledge about the system during their involvement in knowledge acquisition or in providing any other support to the researcher, while those in domain experts (Group II) do not have. However, these variations may easily be avoided by providing appropriate orientation to those experts who did not have prior knowledge about the system.

The results were compared with previously conducted researches using user acceptance test. For example, Ethiopia (2002) was conducted a research on labor law and evaluated using domain experts. So, the average result showed very good as evaluated by domain experts who have prior knowledge about the system during the different phase of the research while good for those who have no prior knowledge about the system. Similarly, Yemmisrach (2009) conducted on children criminal cases using CBR on legal domain. As evaluated by legal experts, the system showed encouraging results which is more than average (i.e. good).

In general, the results about the evaluation for the performance of the prototype system by the two groups of domain experts are more than the average value for all evaluated criteria defined in this study. This shows that a promising result is achieved using user acceptance testing as compared to previously conducted researches.

CHAPTER SEVEN

CONCLUSIONS AND RECOMMENDATIONS

7.1 Conclusion

Research using CBR is potentially useful in medical domain, HIV/AIDS, in particular. This research output provides useful information for physician to support decision in managing HIV patient cases. CBR can be used as a corporate memory system for retaining the valuable experience of physicians which can provide insight and consistence in solving future problems.

The study was conducted with the aim to explore the possible application of case-based reasoning approach of knowledge-based system of clinician consultation services in managing side effects of HIV/AIDS cases and develop a prototype, which assists health-care workers in providing advice and treatment to individual HIV cases. For this purpose, the knowledge was acquired from clinician consultation services provider experts in ARC (Warmline) of Ethiopia through interview, personal observation, document analysis and recorded cases; and a hierarchical tree modeling technique was employed in order to model the knowledge of domain experts.

Both the tacit and explicit knowledge for the study was acquired from domain experts and then case features were formulated, a case structure comprising relevant attributes which will have direct impact to decision on treating and diagnosing the side effect of ARV medication on HIV patients was also identified. Case-based reasoning approach is employed in representing the necessary knowledge required for handling HIV cases. The case-base was developed using JCOLIBRI, which is the most compatible and reliable CBR tool to deal with case-based system.

Rule-based system performs poorly outside its boundaries. It is restricted with facts and rules which is in the knowledge-base but not when new cases are arriving. Because of the closed world assumption rule-base system needs all facts should be known to the system this implies that unknown facts are false. As a result, pure rule-based system representations are too weak to represent the complexity of the real world.

This shows that rule-based system is not effective in medical domain including HIV/AIDS case management which is extremely incomplete and context dependent to support physician in solving problems. In contrast, case-based systems use past experience as the domain knowledge and can often provide a reasonable solution, through appropriate adaptation, to these types of problems. As cases are retrieved, they may not be identical to the current case. However, when they are within some defined measure of similarity to the present case, any incompleteness and imprecision can be dealt with by a case-based reasoner. In addition, CBR does seem to address many of the shortcomings of RBS, particularly the ability of the systems to learn incrementally and to provide highly contextualized explanations.

The present research designs a prototype case-based reasoning system for side effect of HIV/AIDS case associated with ARV drugs to see if further expansion is possible; and based on the initial investigation it is found out that it is possible to track along similar problem domain.

The retrieval task starts with a new case description, and ends when best matching similarity case of ADR/side effect cases has been found in the case-base. As users enter case description (query) through the parameter requested window, the system searches the best matching cases from the case-base and return possible solution in ranked order to the problems described in the query. If exact matching occurred in between the query and cases in the case-base, users can directly derive the solution or if the similarity or matching is partial, then reuse and revision tasks are done manually by experts to make the proposed solution best suit for the problem at hand. At last, those best modified solution to the problem stored to the case-base for future use.

The prototype was tested and verified by comparing the solution attained by prototype with previously recommended cases by selected human experts. The result showed that most similar cases were retrieved when all the attributes of a new case was similar to the cases in the case-base. It was also found that useful cases which could help physicians for recommendations are included in partial matching cases. The performance of the CBR system was evaluated and validated using user acceptance testing and statistical analysis (i.e. precision and recall). Thus, the result of the test and evaluation showed that the system produced acceptable and promising results.

7.2 Recommendation

The focus of this study was to apply CBR for managing HIV/AIDS cases which help physicians in treating patients using past experience. As explained in the previous section, the goals of the research have been achieved. Nevertheless, and as expected, improvements and open issues are still pending since there is always a room for improvement. Thus, the next tasks is to recommend some potential problem areas which are uncovered by this research.

Consequently, the following recommendations have been made based on this study:

- The collected raw cases for this research were not in the required format initially and involve extracting from large documents consulting with domain experts. It was a challenging task to prepare to the required case structure. For future work, it is better to improve this process by looking at other alternatives (such as NLP) to automatically generate the case structure using other possible techniques.
- Preparation and selection of attributes for CBR system was done manually by considering which attribute could more accredited and recognized in managing adverse drug reaction with the help of domain experts. The researcher suggests as future work to apply machine learning approach such as information gain attribute ranking to generate and construct a set of relevant attributes.
- The use of nearest algorithm leads to the retrieval time increasing linearly with the number of cases and it has also returned the nearest match even though dissimilarities between the source and new input cases. In the future work, it is recommended to use other retrieval algorithms such as template retrieval that returns all cases that fit within certain parameters.
- The system should be enabled to automatically adapt solutions from case-base. Hence, the researcher suggests the exploration of various techniques of adaptation.
- The performance of the system can be improved if a hybrid approach is employed by combining rules, cases and models. The main reason for this is that rules, cases and models

have complementary strengths. Rules capture broad trends in the domain; cases are good at handling specific details, while models are good at handling structural details. Hence, as future further investigation needs to integrate these approaches to make a knowledge-based system more powerful and practical.

- The health service domain, particularly in HIV/AIDS is an active area to be investigated using artificial intelligence, particularly CBR. Though a prototype has been developed in this research to the adverse drug reaction/side effect of anti-HIV medication, there are still other potential areas which need further investigation in HIV/AIDS; like drug interaction, opportunistic infection diseases, prevention of mother to child transmission (PMTCT), laboratory result investigation and others.

References

- Aamodt, A. Plaza, E (1994).** Case-Based Reasoning: Foundational Issues, Methodological Variations, and System Approaches, AICom: Artificial Intelligence Communications, IOS Press, Vol. 7: 1, pp. 39-59.
- Abdrabou,E., & Salem.A. (2008).** Case-based Reasoning Tools from Shell to Object-Oriented Frameworks. XIVth International Conference "Knowledge-Dialogue-Solution" KDS 2008, Varna, Bulgaria.
- Abraham, A. (2005).** Rule-based Expert Systems. Oklahoma State University, Stillwater, OK, USA.
- AETC (2007).** Adverse Reactions to HIV Medications: Clinical Manual for Management of the HIV-Infected Adult. Available at
[http://www.aidsetc.org/aidsetc?page=cm-313_adverse#S2x] accessed on 17, March 2010.
- AIDS Resource Center (2009).** AIDS Hotline for Ethiopian Health-Care Workers. Available at [<http://www.etharc.org/fitun/index.html>] accessed on December 3, 2009.
- Alemayehu Worku&Endrias Markos (2008).** Adherence to ART in PLWHA at Yirgalem hospital, South Ethiopia, Ethiopia, No 22(2). pp.174-179.
- Anteneh Worku (2004).** Design and Development of a Prototype Knowledge-Based System for HIV Pre-test Counseling, MSc thesis, unpublished, Addis Ababa University.
- Ashley, K.D. (1992).** Case-Based Reasoning and its Implications for Legal Expert Systems: Artificial Intelligence and Law, Kluwer academic publisher, Netherlands, No.1, pp.113-208.
- Ashraf, M.H & Iqbal, N. (2006).** Evaluation of JCOLIBRI, Master Thesis report, Malardalen University, Sweden. Available at <http://www.codeproject.com/KB/architecture/commonkadsx.aspx> accessed on 15, March 2010.
- Assegid Tassew (2007).** Assessment of the Prevalence of Adverse Drug Reaction among HIV-infected Adults on Antiretroviral Therapy and Factors Associated with it at Zewditu Memorial Hospital. Master of Thesis, Unpublished, Addis Ababa University.
- AVERT (2010).** Continuing Antiretroviral (ARV) Treatment: AIDS & HIV Information from AVERT.org, the world's most Popular AIDS Website. Available at [<http://www.avert.org/arv-treatment.htm>] accessed on 15, March 2010.

Baig, M. (2008). Case-Based Reasoning: An Effective Paradigm for Providing Diagnostic Support for Stroke Patients. Master's Thesis, Queen's University, Canada.

Bello-Tomas, J.J., González-Calero, P.A., and D'íaz-Agudo, B. (2004). JCOLIBRI: An Object-Oriented Framework for Building CBR Systems, University of Madrid, Spain.

Blenkinsopp, A. et al (2007). Patient reporting of suspected adverse drug reactions: a review of published literature and international experience. *Journal of Clinical Pharmacology*, British Pharmacological Society, v. 63(2), pp 148–156.

Burge, J.E.(n.d). Knowledge Elicitation Tool Classification. Artificial Intelligence Research Group. Worcester Polytechnic Institute. Available at

[<http://web.cs.wpi.edu/~jburge/thesis/kematrix.html>] accessed on April 12, 2010.

Center for Disease Control (2009). Guidelines for Prevention and Treatment of Opportunistic Infections in HIV-Infected Adults and Adolescents, Morbidity and Mortality Weekly Report, Vol. 58 / No. RR-4

Chang, L.W. et al (2008). Telecommunications and Health-care: An HIV/AIDS Warmline for Communication and Consultation. *Journal of the International Association of Physicians in AIDS Care*, Rakai, Uganda, Volume XX Number X.

De Parga, C. J. (2009). Knowledge-Based Systems with the CommonKADS Methodology. Available at [<http://www.codeproject.com/KB/architecture/commonkadsx.aspx>] accessed on June April 10, 2010.

Engelmore, R. S. & Feigenbaum E.(1993). EXPERT SYSTEMS AND ARTIFICIAL INTELLIGENCE. *WTEC Hyper-Librarian*. Available at

[http://www.wtec.org/loyola/kb/c1_s1.htm] accessed on 25/2/2010.

Ethiopia HIV/AIDS prevention and control office (HAPCO) (2009). ART scale-up in Ethiopia: success and challenges, Addis Ababa, Ethiopia.

Ethiopia Tadesse (2002). Application of Case-based Reasoning for Amharic Legal Precedent Retrieval: A Case Study with the Ethiopian Labor Law, MSc Thesis, Unpublished, Addis Ababa University.

Family Health International (2004). Stigma and Discrimination in Nepal: Community Attitudes and consequences for people living with HIV/AIDS.

Family Health International-Ethiopia & HAPCO (2002). Needs Assessment of PLWHA in Addis Ababa, Ethiopia.

Faragon, J.J (2008). Caring for the HIV Infected Inmate: A CME-Accredited Resource for Prescribing Clinicians. HIV Drug Interaction.

Global AIDS Program (2006). Antiretroviral Drugs for All? Obstacles to Access to HIV/AIDS Treatment Lessons from Ethiopia, Haiti, India, Nepal and Zambia.

Goldschmidt R.H. and Graves D.W (2003).The National HIV Telephone Consultation Service (Warmline): A Clinical Resource for Physician Caring for African-American.volL.95,No. 2

HAPCO&MOH (2007). Guideline for Management of Opportunistic Infection and Anti retroviral Treatment in Adolescent and Adults in Ethiopia. Available at

[\[http://www.wtec.org/loyola/kb/c1_s1.htm\]](http://www.wtec.org/loyola/kb/c1_s1.htm) access on 25/2/2010.

Hussar, D.A. (2007). Drug Interaction. The Merck Manuals Online Medical Library: The Merck Manual of Information–Home Edition.

Available at [<http://www.merck.com/mmhe/sec02/ch013/ch013c.html#>] accessed on 15, March 2010.

J. Hopkin (2005). National AIDS Resource Center for Communication Programme: School public Health. Available at [http://www.jhucecp.org/exit_notice.php] accessed on September 12, 2009.

Jones, P.H. (1989). Knowledge Acquisition: Knowledge Engineering in Agriculture. ASAE Monograph , ASAE, St. Joseph, MI, No.8.

Kashyap, K. (1997). An Expert Systems Application in Electromagnetic Compatibility, Master's thesis, University of Missouri-Rolla.

Kumar, K. A., Singh,Y., Sanyal,S.(2009). Hybrid Approach Using Case-Based Reasoning and Rule-Based Reasoning for Domain Independent Clinical Decision Support in ICU. Expert Systems with Applications, 36, pp. 65–71.

Ling L. and Li X. (1999). A hybrid Knowledge-Based System Applied to Epidemic Screening. Expert Systems, Vol. 16, No. 4, pp.248-256.

Lopez de Mantaras, R. (2000). Case-Based Reasoning. IIIA-Artificial Intelligence Research Institute CSIC-Spanish Scientific Research Council. ACAI' 99, LNAI 2049, pp. 127-145.

Lopez R. (2001). Case-Based Reasoning: IIIA-Artificial Intelligence Research Institute CSIC-Spanish Scientific Research Council, ACAI' 99, LNAI 2049, pp. 127-145.

Lee, K.C. (2008).User evaluations of tax filing websites: the international journal of digital information research and use, Sungkyunkwan University, South Korea, Vol. 32 No. 6, pp.842-860.

Luan X. et al (2005). A Fuzzy Discrete Event System for HIV/AIDS Treatment: IEEE International Conference on Fuzzy Systems. Department of Electrical and Computer Engineering, Wayne State University Detroit, MI 48202, USA.

Lützelshwab, S. (2007). Case-based Reasoner for OWL-S Web Services. Diploma Thesis. Department of Informatics, Kaiseraugst AG, Switzerland, Unpublished, University of Zurich.

Maher, M.L. (1995). Case-Based Reasoning in Design [Electronic version]. United States of America. Lawrence Erlbaum Association. Available at

[\[http://books.google.com.et/books?id=X0d8uwGKyvoC&dq\]](http://books.google.com.et/books?id=X0d8uwGKyvoC&dq) accessed on March 12, 2009.

Marfatia,.S. & Smita A, M (2005). Adverse Drug Reaction (ADR) Due to Anti-retroviral (ARV): Issues and Challenges. INDIAN J SEX TRANSM DIS 2005; Vol. 26 No. 1, 2.

Masizana-Katongo, A.N., Leburu-Dingalo, T.K., Mpoeleng, D. (2009). An Expert System for HIV and AIDS Information. Proceedings of the World Congress on Engineering. Vol I WCE July 1 - 3, London, U.K.

Miller, W. A. (2009). Problems Detection for Situations Assessment in Case-Based Reasoning for Diabetes management. A thesis presented to the Faculty of the Russ College of Engineering and Technology, Ohio University, Athen.

MOH& HAPCO (2007). Accelerated Access to HIV/AIDS Prevention, Care and Treatment in Ethiopia. Health Programs Department, ROAD MAP 2007-2008/10.

MOH (2007).National Consensus Meeting on Single HIV Prevalence Estimation: Single point HIV Prevalence Estimate, Palace Hotel, Adama, Ethiopia.

Makhfi (2008). Introduction to Knowledge Modeling: World of Knowledge Modeling, Dortmund University, Germany. Available at[http://www.makhfi.com/KCM_intro.htm] accessed on May 21, 2010.

Okafor, E.C.& Osuagwu,C.C. (2006).The Underlying Issues in Knowledge Elicitation: Interdisciplinary Journal of Information, Knowledge, and Management. Nigeria. Vol. 1.

Oneworld.net (2009). Hotline Bolsters Ethiopian AIDS Workers. OneWorld US& Global Health Council , WASHINGTON.

Philbrick, A.H, et al (2005). Antiretrovirals: Pharmacotherapy and Adverse Drug Reactions. Internet Continuing Education (*InetCE*), University–Chicago College of Pharmacy Downer’s Grove, Illinois Vol.9,No 5.

Phuong, N.H. (n.d). A Fuzzy Rule-based Lung Diseases Diagnostic System Combining Positive and Negative Knowledge. National Center for Natural Science and Technology, Daegu, Korea.

Popa A. et al (2008). Case-Based Reasoning Approach for Well Failure Diagnostics and Planning: Society of Petroleum Engineers, Bakersfield, California, USA.

Prentzas J. and Hatzilygeroudis I. (2007). Categorizing Approaches Combining Rule-Based and Case-Based Reasoning; Expert Systems, Vol. 24, No. 2, pp.97-122.

Rao, S.S. et al (1999). Artificial Intelligence and Expert Systems Applications in new Product Development: A Survey Journal of Intelligent manufacturing. University of Toledo, USA, Vol 10, pp.231-244.

Recio, J.A. (2002). JCOLIBRI 1.0 in a Nutshell. A software tool for designing CBR systems. Department of Sistemas Informatics Programacion Universidad Complutense de Madrid, Spain.

Recio-Garcia,J.A and Daz-Agudo, B (2004). An Introductory User-Guide to JCOLIBRI 0.3. Department of Dep. Sistemas Informatics Programacion Universidad Complutense de Madrid, Spain, Technical Report No 144/2004.

Redit Alemu (2006). Design and Development of a Prototype Knowledge-Based System for Antiretroviral Therapy, MSc Thesis, Unpublished, Addis Ababa University.

Richterm, M. and Aamodt, A. (2006). Case-Based Reasoning Foundations: The Knowledge Engineering Review, Cambridge University Press, United Kingdom, Vol. 20:3, 203–207.

Riedl, M. A. and Casillas, A. M. (2003). Adverse Drug Reactions: Types and Treatment Options. Journal of American Academy of Family Physician. American Family Physician, Vol.68, No 9.

Ronald et al.(2003). National HIV/AIDS Clinicians' Consultation Center, San Francisco General Hospital and the Department of Family and Community Medicine, University of California, San Francisco 94110, USA.

Rudorf, D.C and Krikorian, S.A.(2005). Adverse Effects Associated With Antiretroviral Therapy and Potential Management Strategies. Journal of Pharmacy Practice. 18; 258.

Sajja, P. S. (2008). Multi-Agent System for Knowledge-Based Access to Distributed Databases. Journal of Information, Knowledge, and Management. Sardar Patel University, Gujarat, India, Vol.3.

Salem, A. M. (2007). Case-based Reasoning Technology for Medical Diagnosis. World Academy of Science, Engineering and Technology, pp 9-13.

Shiu, S.K & Pal, S.K (2004). Case-base reasoning: Concepts, features and soft computing, machine intelligent unit, Indian statistical institute, Calcutta,India,21,pp. 233-238.

Shi,X. and Ych, A. (1999). The Integration of Case-Based Systems and GIS in Development Control: Environment and Planning II Planning and Design, volume 26, pp. 345-364.

Stoyanov,S., Govedarova, N. & Popchev,I (2005a), CBR-Based Search in Bulchino Catalogue University of Plovdiv, Bulgaria.

----- **(2005b).** Hybrid Ontology and CBR-based Search in Bulchino Catalogue. Institute of Information Technologies,Bulgarian Academy of Science, University of Plovdiv, Bulgaria.

Strebel, A., Cloete, A.& Simbayi (2009). Social Aspects of HIV/AIDS and Health (SAHA). Human Science Research Council, Botswana.

Stutterheim, S.E. (2008). Positive Living Under Stigma. HIV-Related Stigma in the Netherlands. Ipskamp, Enschede.

Tadele Tedla (2005). Expert for the Legal Regime Governing Women in Ethiopia: The case of the Revised Family Code and Labor Law. Master of Thesis, Unpublished, Addis Ababa University.

Tan, C. (2008). A Prototype of Knowledge-Based System for Fault Diagnosis in Automatic Wire Bonding Machine: Universiti Teknikal Malaysia Melaka, Melaka-MALAYSIA, No.32, pp.235 – 244.

Telecommunications and Health-care (2008). An HIV/AIDS Warmline for Communication and Consultation, Rakai, Uganda.

UNAIDS (2008). HIV/AIDS Statistics Worldwide. Uniting the World Against AIDS, Ethiopia. [<http://www.unaids.org/en/KnowledgeCentre/HIVData/EpiUpdate/EpiUpdArchive/2007/default.asp>] accessed on March 13, 2010.

UNAIDS and WHO (2007). Global summary of the AIDS epidemic, UNAIDS and WHO Available at [http://data.unaids.org/pub/epislides/2007/2007_epiupdate_en.pdf] accessed on February 11, 2010.

_____ **(2007).** Guideline for Implementation of the Antiretroviral Therapy Programme in Ethiopia.

UNAIDS&WHO (2009). Over 33M People Worldwide Living with HIV/AIDS, NAIDS/WHO Report Finds. Kaisy Daily Global Healthy Policy Report.

Available at [[http://globalhealth.kff.org/Daily-Reports/2009/November/24/GH-112409-UNAIDS- Report.aspx](http://globalhealth.kff.org/Daily-Reports/2009/November/24/GH-112409-UNAIDS-Report.aspx)] accessed on 11 march 2010.

UNAIDS (2007). Global HIV Prevalence has leveled off; AIDS is Among the Leading Causes of Death Globally and Remains the Primary Cause of Death in Africa. The complete HIV/AIDS Resource. Available at [<http://www.thebody.com/content/world/art44018.html#>] accessed on 11, March 2010.

UNICEF (2006). HIV/AIDS: PMTCT Plus. Unite against Aids & Unite for Children. Mozambique. Available at [http://www.unicef.org/mozambique/hiv_aids_4091.html] accessed on April 20.2010.

Watson, I. & Marir, F. (1994). Case-Based Reasoning: *AI-CBR*, Dept. of Computer Science, University of Auckland, New Zealand.

WHO (2006). Special Focuses: Complication of Antiretroviral Therapy: HIV/AIDS Antiretroviral New Letter. Issue No. 3. Pp. 2-4.

Witten, I. H and Frank, E. (2005). Data Mining: Practical Machine Learning Tools and Techniques with Java Implementations. Morgan Kaufmann Publishers. San-Francisco.

Yemisrach H/Gebretadik (2009). Application of CBR in Legal KBS: A Prototype on Children Criminal Cases in Ethiopia, MSc Thesis, Unpublished, Addis Ababa University.

Appendices

Appendix I: Sample questions that were asked during the interview with domain Experts

1. Patient profile relevant for treatment
2. What are the major problems in giving appropriate consultative service for health-care worker through telephone?
3. What kinds of cases are usually requested by health-care workers in relation to seeking expertise advice on HIV?
4. What are the problems usually encountered in managing PLWHA?
5. What is adherence? Can poor adherence cause ADR? How?
6. What are the most frequently side effects that arise due to ARV for those PLWHA?
7. What are the important factors that you take into account when making recommendations for patients who are suffering from adverse drug reaction?
8. What are the parameters that should be taken into account in recommending adverse drug reaction for PLWHA associated to ARV?
9. What are the symptoms of adverse drug reaction as a result of ARV?
10. Do you try to use advice through retrieving past recommended cases that could help for current new patient case?
11. How much useful be experienced in treating using pervious decision cases which is similar to the current new patient case situations at hand?
12. What are the most frequently occurring HIV cases that call from health-care workers?
13. Drug toxicity is one of the factors that can help health-care workers to decide the ARV therapy to continue or not. How can you determine levels of drug toxicity?
14. What are the causes of regimen failures? How it can be ensured whether the treatment has failed or not?
15. Can you explain the different OIs diseases you know including their symptoms, control mechanism and how to manage them?
16. How do you manage acute OIs in patients receiving ART?
17. What procedures do you follow to treat an HIV patient when he/she is suffering with the prescribed regimen?

Appendix II: Application design using jCOLIBRI 1.1

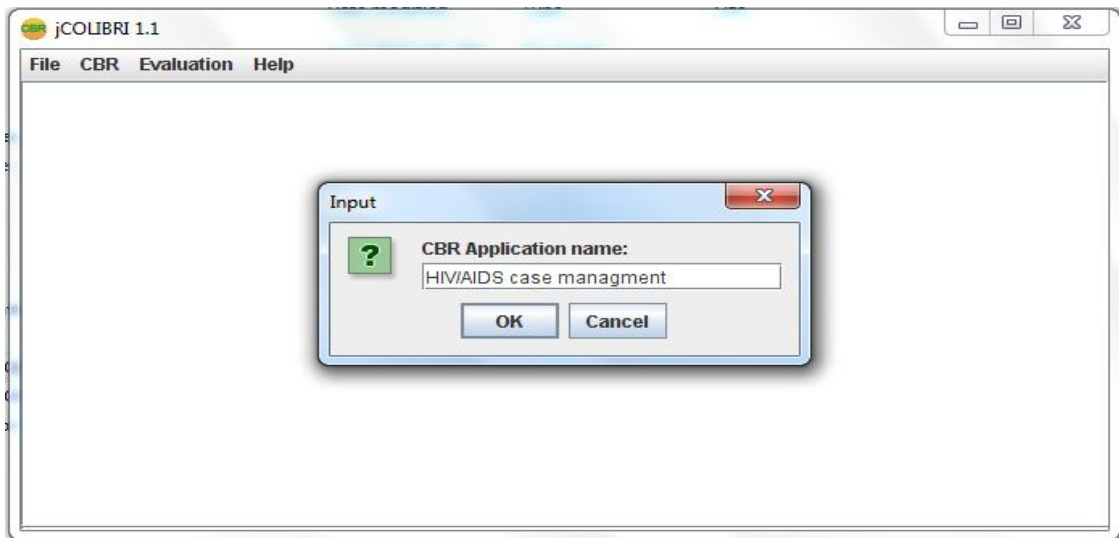

Fig. II.1 Window to start new application

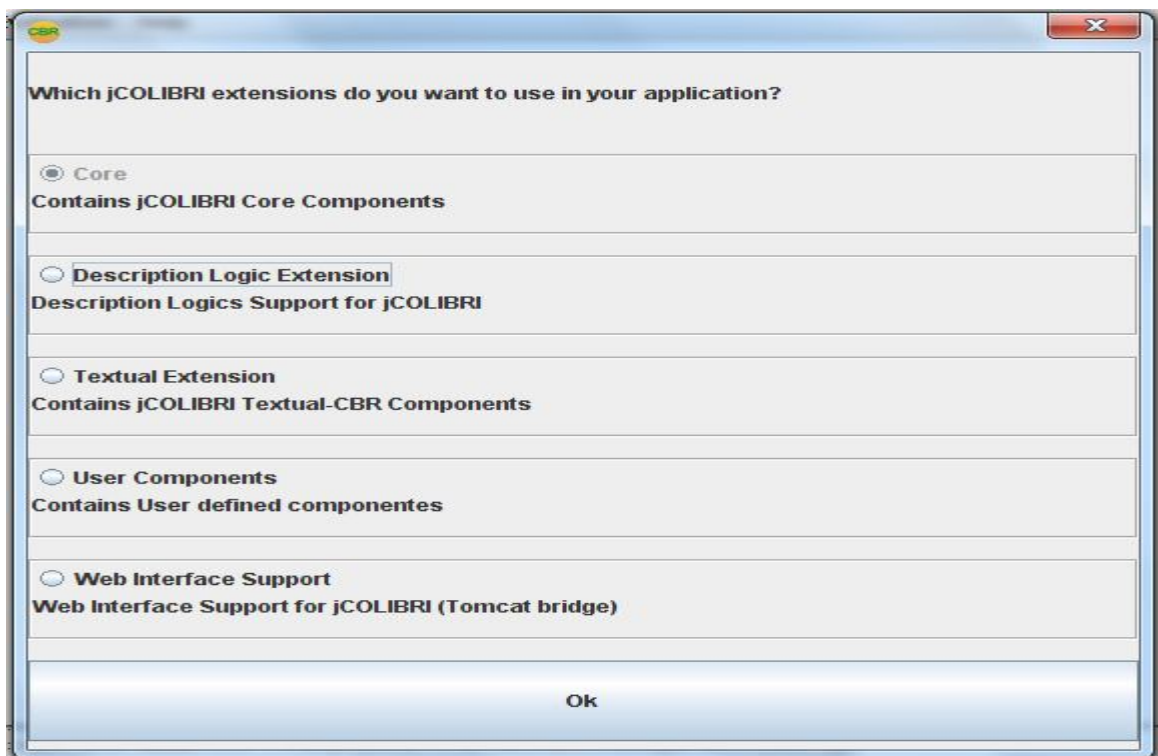

Fig. II.2 Extension for application that support in jCOLIBRI

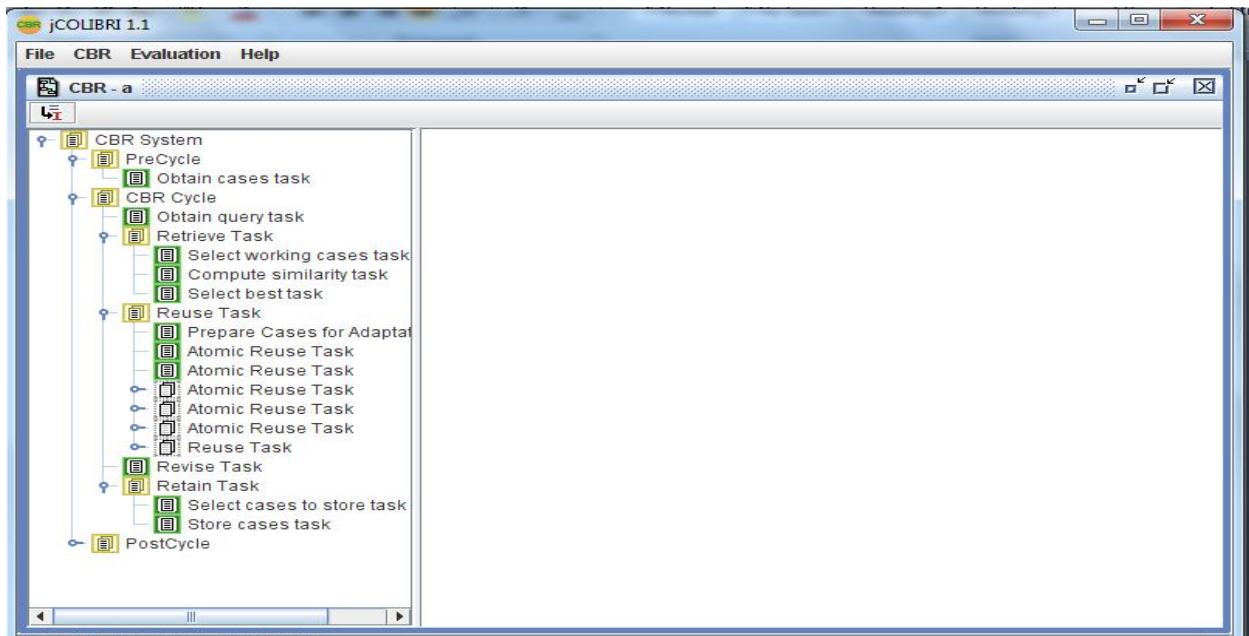

Fig. II.3 the four main cycle of CBR application

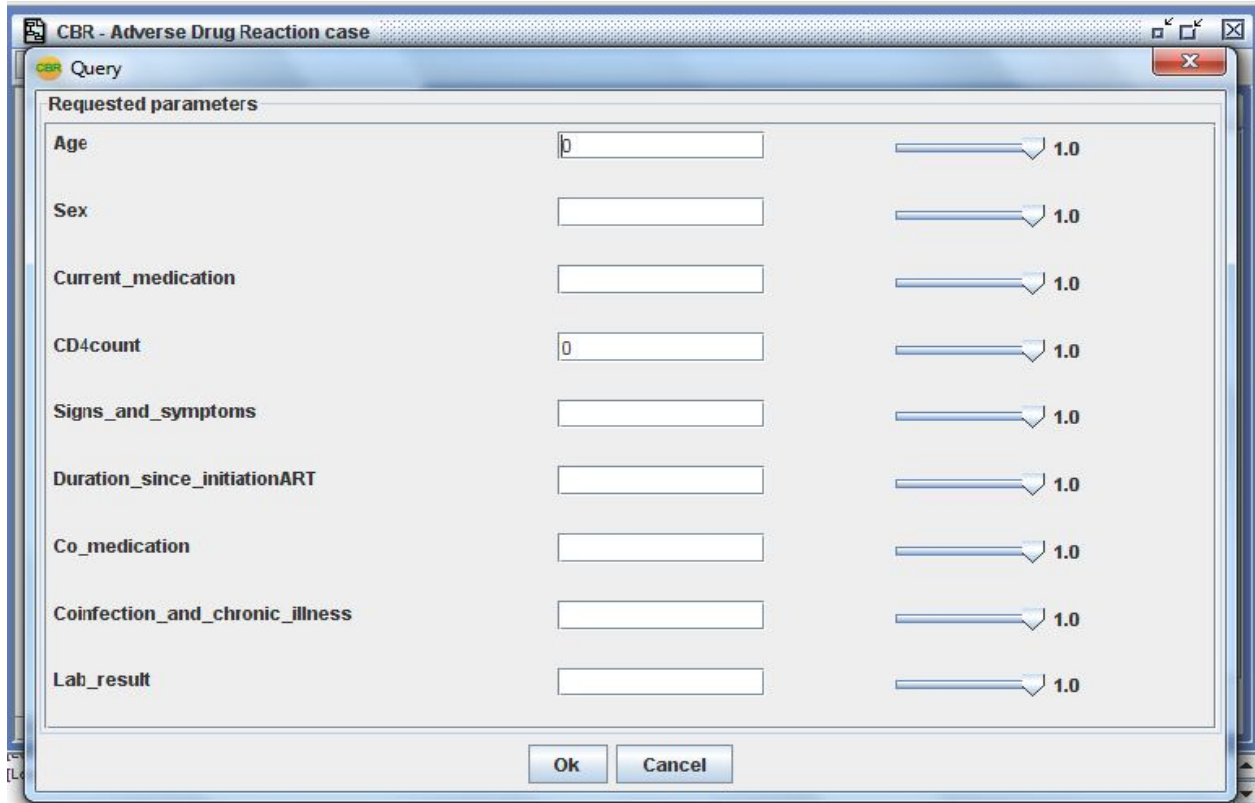

Fig II.4 Windows for case entry into the case-base

Appendix III: The window as shown below indicates some sample case similarity query result window

The screenshot shows a window titled "Results" with a list of two cases. Each case is followed by a series of key-value pairs representing patient data and clinical details. Case 35 includes details like CD4 count, rash severity, co-medication, illness, sex, lab results, current medication, age, and duration since ART initiation. Case 36 follows a similar structure but with different values for some attributes like rash severity and age. Both cases conclude with a "Recommendations" field providing clinical advice.

Results

WORKING CASES:

case35

has-Description: Description

has-Description.CD4count: 160

has-Description.Patient_severity: maculopopular rash

has-Description.Co_medication: CTM prophylaxis

has-Description.Illness: hepattics

has-Description.Sex: F

has-Description.Lab_result: SGOT468 SGPT420 ALP523

has-Description.Current_medication: 1a

has-Description.Age: 48

has-Description.Duration_since_initiationART: 1month

has-Result: Result

has-Solution: Solution

has-Solution.Recommendations: the patient is on NVP with grade 4 toxicity so all_drug should be stopped

case36

has-Description: Description

has-Description.CD4count: 160

has-Description.Patient_severity: maculopapular rash all overbody

has-Description.Co_medication: no

has-Description.Illness: hepattis

has-Description.Sex: F

has-Description.Lab_result: SGOT468 SGPT420 ALP523

has-Description.Current_medication: 1a

has-Description.Age: 43

has-Description.Duration_since_initiationART: 1month

has-Result: Result

has-Solution: Solution

has-Solution.Recommendations: patient is on NVP with grade 4 toxicity all drugs should be stopped and treated with symptomatic (antihistamine) and supportive therapy

case37
has-Description: Description
has-Description.CD4count: 160
has-Description.Patient_severity: maculopapular rash all overbody
has-Description.Co_medication: no
has-Description.Illness: hepatitis
has-Description.Sex: F
has-Description.Lab_result: SGOT468 SGPT420 ALP523
has-Description.Current_medication: 1a
has-Description.Age: 43
has-Description.Duration_since_initiationART: 1 month
has-Result: Result
has-Solution: Solution
has-Solution.Recommendations: patient is on NVP with grade 4 toxicity all drugs should be stopped and treated with symptomatic (antihistamine) and supportive therapy

CASE BASE: 37 cases

QUERY:

has-Description: Description
has-Description.CD4count: 160
has-Description.Patient_severity: maculopapular rash
has-Description.Co_medication: CTM prophylaxis
has-Description.Illness: hepatitis
has-Description.Sex: F
has-Description.Lab_result: SGOT468 SGPT420 ALP523
has-Description.Current_medication: 1a
has-Description.Age: 48
has-Description.Duration_since_initiationART: 1 month

Fig. IV.1 case similarity query result window

DECLARATION

I, the undersigned, declare that this thesis is my original work and has never been presented in this or any other university and that all sources of materials used for the thesis have been duly acknowledged.

Alemu Jorgi Muhammed

June 2010

The thesis has been submitted for examination with my approval as university advisor

Ato Getachew Jemaneh

June 2010