

**Ecosystem structure, trophic link and functioning of a shallow rift  
valley lake: the case of Lake Ziway (Ethiopia)**



---

**A Thesis Submitted to the School of Graduate Studies, Addis Ababa University in  
Partial Fulfillment of the Requirements for the Degree of Master of Science in  
Biology (Fisheries and Aquatic Sciences Stream)**

**By  
Mathewos Hailu**

**June, 2011**

## ACKNOWLEDGMENTS

My gratitude goes to my advisor, Dr. Tadesse Fetahi who persistently guided me throughout this study, through innovative ideas and patience. I am indebted to him for his positive critic's right from the time I started data collection, up to the actual modeling and data analyses. I will always remember the interventions you made, creating a straighter path throughout my research.

Many sincere thanks goes to Dr. Seyoum Mengistou, my co advisor who, encouraged me to work on Ecopath Modeling of Lake Ziway, besides my academics you gave me a lot of encouragement and comments about my work. Thank you for the support you accorded me during my study. I am also indebted to Dr. Demeke Kifle for his unreserved support concerning phytoplankton and Dr. Abebe Getahun for his help on identification of Garra.

I wish to extend my thanks to all colleagues at fisheries and aquatic sciences stream, for their valuable encouragement and time during my research and study. Special thanks to Girum Tamire, who helped me in identification of macrophyte; Getachew Beneberu for his help in identification of some macro-zoobenthos, thank you all, for the time you took while brain storming on numerous ideas about my work in one way or the other.

I would also like to appreciate the funding from Rural Capacity Building Project and the leave of absence from Oromia Agricultural Research Institute. I am in deed grateful to my colleagues at Ziway Fisheries Resources Research Center; especially Abraham G/Tsadik, Lemma Abera, Tagay Bekele, Dawit Imiru and Qasim Indris for their friendship support and encouragement during my data collection period. Lastly, I am beholden to my Families who were always beside me through their indescribable support and help. Without whom, I could never have made it.

## TABLE OF CONTENTS

ACKNOWLEDGMENTS .....	i
LIST OF TABLES .....	iv
LIST OF FIGURES .....	v
LIST OF APPENDICES .....	vi
LIST OF ACRONYMS .....	vii
ABSTRACT.....	viii
1. INTRODUCTION .....	1
2. OBJECTIVES .....	6
3. MATERIALS AND METHODS.....	7
3.1. Study site.....	7
3.2. Ecopath model description.....	8
3.3. Ecological grouping .....	9
3.4. Phytoplankton biomass estimation .....	10
3.5. Zooplankton .....	10
3.5.1. Abundance and biomass estimation.....	10
3.5.2. Consumption/biomass ratio .....	11
3.6. Macro-zoobenthos.....	11
3.6.1. Abundance and biomass .....	11
3.6.2. Production/biomass ratio .....	12
3.6.3. Consumption/biomass ratio .....	12
3.7. Macrophyte .....	13
3.8. Detritus biomass.....	13
3.9. Fisheries .....	13
3.9.1. Biomass of commercially exploited fish.....	13
3.9.2. Biomass of non-commercially exploited fish .....	14

3.9.3. Production/biomass ratio .....	14
3.9.4. Consumption/biomass ratio .....	15
3.10. Parameterization and model balancing .....	16
3.11. Trophic level organization .....	16
3.12. Network analyses .....	17
3.13. Ecosim simulations .....	18
4. RESULTS AND DISCUSSION .....	20
4.1. Phytoplankton biomass and production .....	20
4.2. Zooplankton .....	22
4.2.2. Production/biomass ratio .....	24
4.2.3. Consumption/biomass ratio .....	25
4.3. Macro-zoobenthos.....	25
4.3.1. Abundance and biomass .....	25
4.3.2. Production/biomass ratio .....	26
4.3.3. Consumption/biomass ratio .....	27
4.6. Fisheries .....	28
4.6.1. Biomass of commercially exploitable and non-exploitable fish.....	28
4.6.2. Production/biomass ratio .....	29
4.7. Model output.....	30
4.8. Trophic structure and biomass flow.....	32
4.9. Mixed trophic impact (MTI) analysis .....	38
4.10. Ecotrophic Efficiencies (EE) .....	41
4.11. Summary statistics .....	42
4.12. Ecosim output .....	44
5. CONCLUSION AND RECOMMENDATION.....	48
6. REFERENCES .....	50
7. APPENDICES .....	61

## LIST OF TABLES

<b>Table 1.</b> Functional groups used as Input for Ecopath with Ecoism of Lake Ziway .....	9
<b>Table 2.</b> List of zooplankton species in Lake Ziway.....	22
<b>Table 3.</b> Biomass value of zooplankton species in Lake Ziway .....	24
<b>Table 4.</b> Growth and other fish parameters used for the estimation of consumption biomass .....	29
<b>Table 5.</b> Input values used for the Ecopath model of Lake Ziway.....	30
<b>Table 6.</b> Diet compositions of functional groups in Lake Ziway ecosystem model .....	31
<b>Table 7.</b> Balanced parameters of Lake Ziway as estimated by Ecopath with Ecosim.....	32
<b>Table 8.</b> Transfer efficiency of aggregated trophic levels in Lake Ziway .....	35
<b>Table 9.</b> Primary production required for the catch groups of Lake Ziway ecosystem ...	42
<b>Table 10.</b> Ecosystem indicators describing Lakes Ziway, Hayq and Awassa ecosystem structures .....	43

## LIST OF FIGURES

Fig. 1 Map of Lake Ziway .....	7
Fig. 2 Temporal variation of Chlorophyll <i>a</i> pigments in Lake Ziway.....	20
Fig. 3 Temporal variations in zooplankton community of Lake Ziway .....	23
Fig. 4 Distribution of macro-zoobenthos families biomass in Lake Ziway.....	26
Fig. 5 Annual catch of fish by Beach seine and gill net in Lake Ziway between year 2008 and 2010 .....	28
Fig. 6 The aggregation of the flows ( $\text{tkm}^{-2}\text{year}^{-1}$ ) into a connected chain of transfers ....	34
Fig. 7 Graphic representations of trophic structure and biomass flow in Lake Ziway ecosystem. ....	37
Fig. 8 Total MTI of each impacting group on the Lake Ziway ecosystem.....	38
Fig. 9 MTI of Lake Ziway Ecosystem .....	40
Fig. 10 Relative changes in biomass associated with increasing the mortality of catfish to 1.50 times (A) and 2.00 times (B). ....	44
Fig. 11. Relative changes in biomass associated with decreasing the effort of beach seine by 0.25 times (A) and 0.50 times (B) the current effort level. ....	45
Fig. 12 Relative changes in biomass associated with increasing the effort of Long line to 1.50 times (A) and 2.00 times (B) the current effort level. ....	46

## **LIST OF APPENDICES**

<b>Appendices 1</b> Phytoplankton identified from Lake Ziway during the study period.....	61
<b>Appendices 2</b> Macro-zoobenthos communities of Lake Ziway.....	61
<b>Appendices 3</b> Absolute flow at aggregated trophic level in Lake Ziway ecosystem .....	62
<b>Appendices 4</b> Cycles and pathways in Lake Ziway Ecosystem .....	62

## LIST OF ACCRONYMS

B	Biomass
Chl a	Chlorophyll a
EE	Ecotrophic Efficiency
EwE	Ecopath with Ecosim
F	Fishing mortality
LFDP	Lake Fisheries Development Project
M	Natural mortality
MTI	Mixed Trophic Impact
P/B	Production/ Biomass ratio
PPR	Primary Production Required
Q/B	Consumption/biomass ratio
TE	Transfer Efficiency
TL	Trophic Level
TST	Total System Throughput
Z	Total mortality
ZFRRC	Ziway Fisheries Resources Research Center

## ABSTRACT

*A trophic model was constructed for the Lake Ziway ecosystem using Ecopath with Ecosim application software. This model was used to evaluate and analyze the food web structure and other properties of this ecosystem. The mean Chlorophyll a biomass of 70.46  $\mu\text{g L}^{-1}$  was found which is higher than those of earlier reports. Wet weight value of phytoplankton was estimated to be 15.99 tons  $\text{km}^{-2}$ . A total of 4 cladocerans and 2 copepods were identified. The biomass of zooplankton is dominated by Thermocyclops (127.73 mg WW  $\text{m}^{-3}$ ). A total of fourteen families of macro-zoobenthos were identified which were dominated by chironomids (15924 individuals  $\text{m}^{-2}$ ) that were attached with the macrophyte *Typha angustifolia*. The above ground biomass of macrophytes vegetation of Lake Ziway was estimated as 3011.68 tons WW  $\text{km}^{-2}$ . The total mortality value for Carp and Catfish was 0.74 and 1.34  $\text{year}^{-1}$  respectively. The total annual catch from Lake Ziway was estimated at 1127 tons based on the catch and effort data (2008–2010). The estimated annual catch in tons per gear type was 683.11, 62.97 and 295.98 for beach seine, gill net and long line, respectively. The results of Ecopath with Ecosim modeling showed the presence of six aggregated trophic levels (TLs). The fractional trophic level assigned TLs of Lake Ziway ecosystem between 1.0 and 3.29. The biomass flow was highly restricted to I and II trophic levels which contributed 99.76 %. The mean transfer efficiency was only 4.4%. The fishery catch consumed 2.5% of the primary production in the lake. Low ecotrophic efficiency (EE) of 0.47 was calculated for the phytoplankton indicating that most of the production remains within the system unutilized. A high value of EE was noted for carp (0.99), indicating that it is subjected to high fishing pressure despite its low biomass. In Lake Ziway, EE values were high for all fish groups, indicating that the fish groups were highly constrained by a combination of fishing and predation mortality. Management scenario using Ecosim analysis indicated that increasing catfish mortality by 1.50 times resulted in increment of tilapia to 1.6 times the current biomass in four years period and leveling of its biomass to 1.16 times the current value at the end of the tenth year. Doubling in mortality of catfish resulted in increment of tilapia biomass to 1.12 times the current biomass. Decreasing the effort of beach seine did not benefit the tilapia group as their biomass declined to 0.98 and 0.66 which is related to biomass increment of catfish. The final scenario of increasing the effort long line by 1.50 and 2.00 times benefited tilapia and significantly decreased the catfish community from the ecosystem. The total analysis indicated that lake Ziway ecosystem has an open niche which can be filled with obligate herbivores to increase the energy transfer efficiency of the lake.*

**Key words:** Ecopath with Ecosim, Biomass, Transfer efficiency, Trophic modeling, Species introduction

## 1. INTRODUCTION

Freshwater ecosystems have been subjected to various environmental and human induced changes throughout the globe for centuries (Alfred, 2002; Magadza, 2010). The changes associated with environmental degradation range from loss of biodiversity to complete loss of ecosystems (Brook Lemma, 2003; Canonico *et al.*, 2005; Tenalem Ayenew and Dagnachew Legesse, 2007). In recent years, the establishment of increasing human populations as well as intense agricultural practices in the catchment has resulted in significant degradation and loss of pristine ecosystems (Harte, 2007). Interventions in fisheries management so as to meet the increasing demand for fish has resulted in overexploitation particularly the commercially important fish species (Matsuishi, 2006). Furthermore, introduction of exotic species has also been practiced to enhance fisheries and filling the available niche in ecosystems (Welcomme, 1988). However, unintended negative impact either to specific species or the whole ecosystem could arise due to introduction (Witte *et al.*, 1992).

Changes associated with the above practices generally provoke diverse biological processes or responses that are interrelated to each other (Vitule *et al.*, 2009; Woodward, 2009). The main reason for the cascading effect in aquatic ecosystem is that, species interact biologically and are interconnected through the food webs (Pascual and Dunne, 2006). The interaction may result in leaving more tolerant species to persist while less tolerant species are eliminated (Vitule *et al.*, 2009).

Understanding the energetic forces of ecosystem functioning and the resilience capacity of natural systems to anthropogenic and/or natural changes are the fundamental goal of

aquatic ecology (Nielsen and Muller, 2009). Since aquatic ecosystems are complex in terms of spatial, temporal and trophic organization, systematic studies regarding ecosystem functioning and structure necessitates quantification of trophic relationships between functional groups in the system (Christensen *et al.*, 2005). This is one of the reasons that Polovina (1984) developed Ecopath, a steady state model of trophic interactions in ecosystem, and modified and further developed in to Ecopath with Ecosim (EwE) with the modelers (Christensen and Pauly, 1993; Walters *et al.*, 1999; Christensen *et al.*, 2005). The relative simplicity of EwE is apparent in its application to several marine and freshwater ecosystems as well as to a farming system (Christensen *et al.*, 2005; Kipkemboi, 2006).

EwE models have been used to examine energy budgets (Coll *et al.*, 2006; Yunkai-Li *et al.*, 2009), trophic structures (Machena *et al.*, 1993; Mavuti *et al.*, 1996) and network analyses in aquatic ecosystems (Coll *et al.*, 2006; Villanueva *et al.*, 2008). The impact of fisheries within their ecosystem context has also been studied using EwE model (Bundy and Pauly, 2001; Arreguin-Sanchez *et al.*, 2002). Furthermore, the model has been used for comparing ecosystems through time (Neira *et al.*, 2004; Tadesse Fetahi *et al.*, 2011) and the impact of various harvesting strategies on the components of ecosystem in particular and the ecosystem in general (Hossain, *et al.*, 2010).

Freshwater ecosystem provides a broad variety of valuable goods and services for human societies; some of which are irreplaceable (Covich *et al.*, 2004). The value of this biodiversity has several components: its direct contribution to economic productivity (e.g. fisheries); its value as a storehouse of genetic information; and its value in supporting the

provision of ecosystem services (e.g. cleaning water) (Pearce, 1998). Lake Ziway, a freshwater habitat in the rift valley, has supported the livelihoods of the surrounding communities through fishing for decades. The fisheries activity of the lake was intensified from the funding acquired from Lake Fisheries Development Project (LFDP) (Felegeselam Yohanes, 2003). The annual sustainable yield of the lake was estimated to be 2000 tons year<sup>-1</sup> (Schroder, 1984), despite the previous intensified fishing of 3200 tons year<sup>-1</sup> (Felegeselam Yohanes, 2003). The fisheries of Lake Ziway production contribute the second largest annual fish of the rift valley lakes, next to Lake Chamo that produces 4500 tons year<sup>-1</sup> (LFDP, 1997).

Lake Ziway is relatively one of the most studied lakes in Ethiopia; among several diverse aquatic ecosystems of great importance in the country. Various studies have been made in this lake by recognizing its huge potential in fisheries. Some of these studies are discussed hereafter.

Studies on phytoplankton species composition of the lake has been made through various decades. A total of 122 phytoplankton species were identified by Tsegaye Miheretab (1988) of which 50 species were blue green, 41 green algae and the rest 31 diatoms, dominated by the blue greens *Lyngbya limnetica*, *Microcystis aeruginosa*, and *Synechococcus elongates* (blue green algae). The latter studies by Elizabeth Kebede and Willen (1998) reported 67 taxa. According to the studies made by Girma Tilahun (2006), although *Microcystis* spp dominated the phytoplankton community of Lake Ziway, unlike the previous studies the numbers of phytoplankton species was only 58. Primary

production and biomass studies of the lake have also been made by Girma Tilahun (1988, 2006); Zinabu Gebremariam *et al.* (2002) with a wide range of alternating values.

The zooplankton community in the lake consists of copepods which are dominated by *Thermocyclops decipensis* and *Mesocyclops aequatorialis*; a less abundant species of copepoda, *Afroscyclops gibsoni* was also reported by Adamneh Dagne *et al.* (2008). Cladocerans of the lake include *Ceriodaphnia cornuta*, *Diaphanosoma excisum*, *Alona diaphana* and *Moina micrura* (Adamneh Dagne *et al.*, 2008). *Alona diaphana*, which is known to be littoral in its distribution, was also found to be limnetic in Lake Ziway (Fernando *et al.*, 1990). Rotifers of Lake Ziway have been studied by Green and Seyoum Mengistou (1991); Semeneh Belay (1988) and Adamneh Dagne *et al.* (2008). Forty-nine rotifer species were recorded which were dominated by *Brachionus angularis*, *Filinia novaezealandiae*, and *Trichocerca ruttneri* (Adamneh Dagne *et al.*, 2008).

The fisheries research in Lake Ziway up to now has focused on the taxonomy (Golubtsov *et al.*, 2002, Stiassny and Abebe Getahun, 2007; Eshete Dejen *et al.*, 2010) biology (Zenebe Tadesse, 1988; Eyuaalem Abebe and Getachew Tefera, 1992; Demeke Admassu and Ahlgren, 2000; Daba Tugie and Mesert Taye, 2004; Alemayehu Negassa and Abebe Getahun, 2003), ecology (Zenebe Tadesse, 1988; Alemayehu Negassa and Parabu, 2008), and stock assessment (LFDP, 1996, 1998; Felegeselam Yohannes, 2003; Gashaw Tesfaye, 2006) of the fishes of the lake.

There are six indigenous fish species in the lake comprising *Barbus ethiopicus*, *Barbus paludinosus*, *Labeobarbus intermedius*, *Garra makiensis*, *Garra dembecha* and *Oreochromis niloticus* (Golubtsov *et al.*, 2002; Eshete Dejen *et al.*, 2010). The lake also

harbors four exotic fish species (*Tilapia zillii*, *Carassius carassius* and *Carassius auratus*) which were introduced to enhance its production and *Clarias gariepinus* that slipped into the lake accidentally (Golubtsov *et al.*, 2002).

Despite several studies done for Lake Ziway on various species and limnological aspects separately, no attempt has been made to understand the structure and functioning of the lake through trophic interactions and analysis from the ecosystem perspectives. Therefore, this study aims to characterise the structure and trophic interactions of Lake Ziway employing an ecological model named Ecopath with Ecosim (EwE). The study also provides a preliminary assessment of the fishery industry to target species and to the whole ecosystem.

## **2. OBJECTIVES**

### **2.1. General objective**

To understand the structure and functioning of Lake Ziway ecosystem from a holistic perspective, and provide data for better utilization of resource.

### **2.2. Specific objectives**

- To estimate and/or compile the current biomass of phytoplankton, zooplankton, macro-zoobenthos and macrophyte in Lake Ziway.
- To estimate production, consumption of macro-zoobenthos, in Lake Ziway.
- To estimate the biomass and basic biological parameters of fish groups in Lake Ziway.
- To produce energy flow diagram and mixed trophic impact for different functional groups in the lake.
- To simulate different harvesting strategies for key functional groups in Lake Ziway using the ECOSIM routine.
- To recommend appropriate fisheries resource enhancement.

### 3. MATERIALS AND METHODS

#### 3.1. Study site

Lake Ziway (also Zwai, Zwei and Zeway) is located at about 160 km south of Addis Ababa ( $7^{\circ}52'$  to  $8^{\circ}8'$  N latitude and  $7^{\circ}52'$  to  $38^{\circ}56'$  longitude (Makin *et al.*, 1975)), (Fig 1.). The lake is situated at an altitude of 1636 m above sea level with a surface area of  $434 \text{ km}^2$  and mean depth of 2.5 m (Wood and Talling, 1988). The lake is fed by rivers, Maqii from the north-west and Katar from the east and it has an outflow through Bulbula River, draining into Lake Abijata. In addition to supporting commercial fishery of the country, the lake water is also used for irrigation and drinking water.

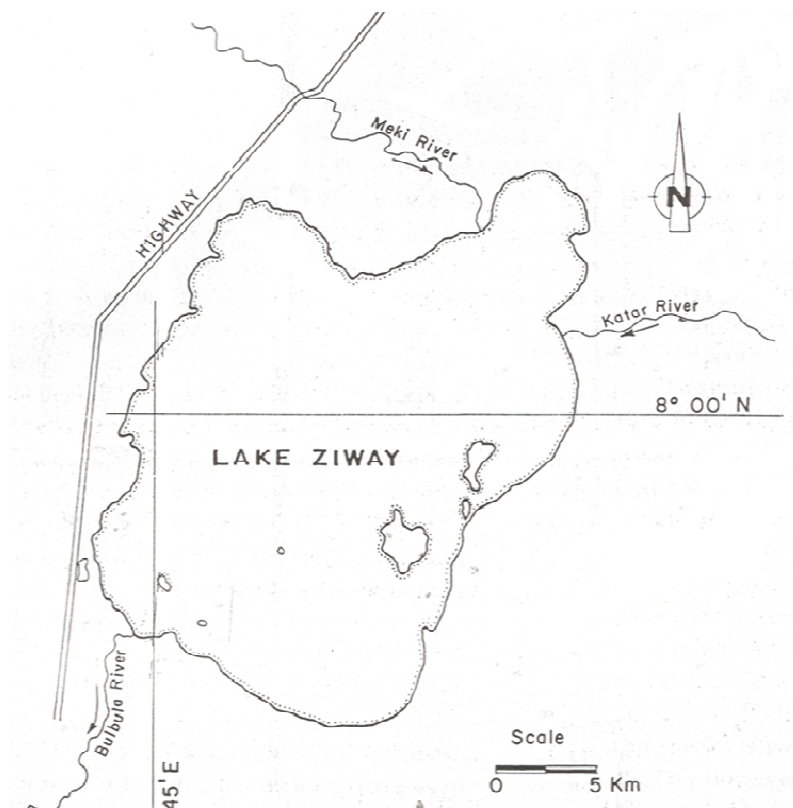

Fig. 1 Map of Lake Ziway

### 3.2. Ecopath model description

Ecopath models are mass-balance models that describe energy pathways in a food web. The model has been extensively used to quantify ecosystem attributes of various ecological processes or stressors (Christensen *et al.*, 2005). In this study, Ecopath with Ecosim (EwE) software (version 5.1) was used to evaluate trophic interactions and energy fluxes within the Lake Ziway food web. The master equation for Ecopath is:

$$B_i \left(\frac{P}{B}\right)_i EE = \sum_{j=1}^n B_j \left(\frac{Q}{B}\right)_j DC_{ij} + B_i \left(\frac{P}{B}\right)_i (1 - EE_i) + EX_i$$

Where:  $B_i$  is the biomass of group  $i$  (in tons  $\text{km}^{-2}$  fresh weight);  $(P/B)_i$  is the annual production biomass ratio of  $i$  which equals the total mortality coefficient ( $Z$ ) in steady-state conditions (Allen, 1971);  $EE_i$  is the ecotrophic efficiency representing the part of the total production consumed by predators or captured in the fishery or exported;  $B_j$  is the biomass of the predator group  $j$ ;  $Q/B_j$  is the annual food consumption per unit biomass of the predatory group  $j$ ;  $DC_{ji}$ , is the proportion of the group  $i$  in the diet of its predator group  $j$ ;  $EX_i$ , is the export or catch in fishery of group  $i$ , that is assumed to be exploited in the fishery (Christensen *et al.*, 2005).

Consequently for each entity (functional group) modeled in Ecopath, information is required on production/biomass ( $P/B$ ), consumption/biomass ( $Q/B$ ), biomass ( $B$ ), proportion of habitat area occupied, biomass in habitat area (tons  $\text{km}^{-2}$ ), diet composition and fishing mortality.

### 3.3. Ecological grouping

Sampling of various groups was conducted from September 2010 to March 2011. Previous studies on the lake were also reviewed to classify organisms according to their functional groups. In Ecopath, functional groups can be composed of species, groups or ontogenetic fractions of a species (Christensen and Walters, 2004). Similarity of the habitat, diet and life history characteristics were considered to formulate a total of 11 functional groups (Table1).

Table 1 Functional groups used as input for EwE of Lake Ziway

No	Functional group	Group members
1	Waterfowls	Great white Pelican, Cormorant, African fish eagle and king fisher
2	Cat fish	<i>Clarias gariepinus</i>
3	Carp	<i>Carassius auratus</i> and <i>Carassius carrausius</i>
4	Tilapia	<i>Oreochromis niloticus</i> and <i>Tilapia zilli</i>
5	Barbus	<i>Barbus paludinosus</i>
6	Garra	<i>Garra dembecha</i> and <i>Garra makiensis</i>
7	Macro-zoobenthos	Insects, Oligochaets, Nematods and Mollusks
8	Carnivores zooplankton	<i>Mesocyclops aequatorialis</i>
9	Herbivores zooplankton	Thermocyclops, Cladocerans and Rotifers
10	Phytoplankton	Cyanophyta, Chlorophyta, Bacilariophyta and Euglenophyta
11	Macrophyte	<i>Typha</i> , <i>Arunda</i> , <i>Echinochola</i> , <i>Potamogeton</i> , <i>Cyprus</i> and <i>Nymphaea sp.</i>

### **3.4. Phytoplankton biomass estimation**

Phytoplankton biomass was determined in terms of Chlorophyll *a* (Chl *a*) concentration. Composite lake water samples, over the euphotic depth were sampled using Kemerer sampler. 250-500 ml of water sample was filtered on glass fiber filter (Whatman GF/C). Chlorophyll *a* concentration was determined spectrophotometrically after extraction of the pigment in cold 90% acetone, and clearing by centrifuging for 10 minutes at 3000 rpm. The absorbance of pigment extracts were measured against a blank at 665 and 750 nm. The concentration of Chl *a* was calculated according to Talling and Driver (1963). No correction was made for degradation products. Consecutively to change the value of Chl *a* into wet weight, as required by EwE; subsequent conversion of Chl *a* to carbon and carbon to wet weight was made. The conversion factor ratio of 40:1 (carbon to chlorophyll) and carbon= 10 % of wet weight (Jones, 1979) was used in the conversion process. The volumetric value was also converted to areal by multiplying with euphotic depth.

### **3.5. Zooplankton**

#### **3.5.1. Abundance and biomass estimation**

Zooplankton samples were collected with 55 µm net through vertical hauls from 2.5-3 m depth. All samples were preserved in 4-5% formalin final concentration. After concentrating the samples; sub samples were poured into a gridded petridish and counted at 50 X magnification under a WILD dissecting microscope. Species were identified using keys of Voigt and Koste (1978); Van de Velde (1984); Defaye (1988), Dussart and Fernando (1988) and Fernando (2002). Adult Cladocera, Copepoda, Rotifera, and immature Copepods (nauplii and copepodites) were counted as separate groups. The final

estimate of the population (individual's  $m^3$  of lake water) was computed using the formula of Edmondson and Winberg (1971).

Biomass of rotifers was calculated from length measurements and bio-volume approximations. Bio-volume of rotifers was computed from linear dimensions applied to simple geometric formulae appropriate to body shape (Ruttner-Kolisko, 1977). Biomass of copepods and cladocerans were calculated based on their body size (total body length, excluding caudal setae); Length-weight relationships of Seyoum Mengistou and Fernando (1991) and Dumont *et al.* (1975) was used for copepods and cladocerans respectively. The biomass in  $m^3$  was converted into  $m^2$  by multiplying with mean depth of the lake (2.5 m).

### **3.5.2. Consumption/biomass ratio**

Consumption/biomass ratio (Q/B) of zooplankton was estimated based on assumed gross food conversion efficiency (P/Q) of 0.2 (Pauly *et al.*, 1993)

## **3.6. Macro-zoobenthos**

### **3.6.1. Abundance and biomass**

Benthic macro invertebrates were collected from a total of five sampling stations. Two of the sampling sites were in the littoral while the others were in the pelagic zone of the lake. Macro-invertebrates in the open water station were sampled using 15 cm x 15 cm Ekman grab. Each grab sample was sieved through a 255  $\mu m$  nitex net and was transferred to sampling bottles. Littoral samples were taken with strong metal hand net of 25 cm x 25 cm frame. To sample the macro invertebrate assemblages associated with

each plant community, the total parts of the vegetations were carefully removed, randomly from 0.25 m<sup>2</sup> quadrant after counting plants within the quadrant.

In the laboratory, sorting was carried out on fresh samples when organisms had their natural colors and were mobile, which contributed to quicker and more efficient sorting. The fresh weight was recorded when specimens were still alive. After sorting into different species, excess water was removed by placing them onto a filter paper. The weight was recorded to the nearest 0.0001 g on digital balance. All the sorted samples of invertebrates were separated, counted and identified to the lowest practical taxonomic level with light microscopy according to keys given by Durand and Leveque (1981) and Bouchard (2004).

### **3.6.2. Production/biomass ratio**

Production/biomass ratio of benthic macro-invertebrates was estimated by dividing production to mean biomass. Production was estimated using the empirical formula of Plante and Downing (1989):

$$\log(P) = 0.06 + 0.79 \log(B) - 0.16 \log(M_{\max}) + 0.05 T$$

Where B: mean annual biomass; M<sub>max</sub>: maximum mass per individual; T: mean annual surface water temperature (°C).

### **3.6.3. Consumption/biomass ratio**

Consumption biomass ratio was estimated based on assumed gross food conversion efficiency (P/Q) of 0.2 (Pauly *et al.*, 1993)

### 3.7. Macrophyte

The fresh weight of macrophyte was estimated by harvesting above ground biomass from (0.5 m x 0.5 m) quadrant. Biomass per square meter was estimated by determining the average biomass per individual stem at each sampled location, and then multiplying this value by the number of stems per square meter (stem density) (Piedade *et al.*, 1991).

### 3.8. Detritus biomass

Detritus biomass was calculated as a function of primary production and euphotic depth by employing the following relationship suggested by Christensen and Pauly (1993).

$$\log D = 0.954 \log PP + 0.863 \log E - 2.41$$

Where D= detritus biomass (g C m<sup>-2</sup>); PP = primary production (in g C m<sup>-2</sup> year<sup>-1</sup>); E = euphotic depth in meter.

### 3.9. Fisheries

#### 3.9.1. Biomass of commercially exploited fish

The commercially exploitable fish species in the lake include Tilapia (*Oreochromis niloticus* and *Tilapia zillii*), Carp (*Carassius auratus* and *Carassius gibelio*) and Catfish (*Clarias gariepinus*). The biomass (B) of each commercially exploitable fish species was estimated assuming equilibrium conditions, such that:

$$B = \frac{Y}{F}$$

Where Y is yield in tons km<sup>-2</sup> year<sup>-1</sup> and F is the coefficient of fishing mortality. Fishing mortality (F) is the difference between total (Z) and natural mortalities (M): F = Z – M, assuming that Z is equal to P/B as indicated by Allen (1971).

Data on annual yield of commercially important fish species was estimated based on data collected by ZFRRC. Estimation of yield was based on catch effort data collected on monthly basis from twelve landing sites. Frame survey on total number of fishermen, number and type of gear as well as active fishing days for various fishing gears has been collected and used in the estimation process.

### **3.9.2. Biomass of non-commercially exploited fish**

Biomass of non-commercially exploitable fish species (*Garra dembecha* and *Garra makiensis*) and straight fin barb (*Barbus paludinosus*) was estimated by hauling a known area along the shore line at different locations of the lake. Twenty five meter long beach seine with a height of four meter was used for hauling. The average catch per net (in terms of weight) was calculated for each site and sampling occasion. Finally the data for all sites and hauling occasion were combined to give an average catch per net. This value was converted into wet weights of biomass km<sup>-2</sup> in tons. The fish species (*Barbus ethiopicus* and *Labeobarbus intermedius*) which were reported from various studies were not observed either in the commercial catch or net setting, therefore they are not included in the current Ecopath with Ecosim modeling.

### **3.9.3. Production/biomass ratio**

The production/biomass ratio of the fish groups, which is equal to total mortality (Z) as indicated by Allen (1971), was estimated from length-frequency distributions using the FISAT software (Gayaniilo *et al.*, 2002) for the Carp and Catfish groups. Estimation of growth parameters (the asymptotic length,  $L_{\infty}$ , and the growth coefficient, K) were

calculated using the ELEFAN I application from length frequency data. Natural mortality (M) was computed using the predictive formula of Pauly (1983) where:

$$\ln(M) = -0.0152 - 0.279 \ln L_{\infty} + 0.6543 \ln(K) + 0.463 \ln(T)$$

Where:  $L_{\infty}$  and K are parameters of Von Bertalanffy Growth Function and T = annual mean surface water temperature of the lake.

Production biomass ratio for unexploited fish species was considered to be equal to natural mortality as they are not impacted by fishing mortality. The Von Bertalanffy growth function k estimated for Lake Awassa was used in the current analysis, while other body parameters were derived from Lake Ziway ecosystem.

#### 3.9.4. Consumption/biomass ratio

The food consumption per unit of biomass (Q/B) was estimated using the multiple regression formula of Palomares and Pauly (1998):

$$\log\left(\frac{Q}{B}\right) = 5.847 + 0.280 \log\left(\frac{P}{B}\right) - 0.152 \log W_{\infty} - 1.360T' + 0.062A + 0.510h + 0.390d$$

Where:  $W_{\infty}$  = fresh weight;  $T' = 1000/\text{Kelvin}$  (Kelvin =  $T^{\circ}\text{C} + 273$ ); A = the aspect ratio of the caudal fin, indicative of metabolic activity and expressed as the ratio of the square of the height of the caudal fin and its surface area. The parameters h and d concern diet h= 1, d = 0 for herbivorous; h = 0, d = 1 for detritivorous and h = 0, d = 0 for carnivorous.

Aspect ratio for each fish groups was made by measuring the area of their caudal tail, using the gird method and dividing to the height of the caudal fin (Palomares and Pauly, 1998).

### **3.10. Parameterization and model balancing**

Once all required parameters of all functional groups are determined and entered in EwE model, the model demands mass-balancing through parameterization. In order to balance the model, parameter estimates derived from other systems or estimated values were, modified to conform with the prerequisite of Ecopath, in which all Ecotrophic Efficiencies (EE) less than 1.0 and gross efficiency (P/Q) from 0.1 to 0.3 a criteria that indicate mass balance of the system.

### **3.11. Trophic level organization**

The structure of a given ecosystem can be characterized by the biomass proportion at each trophic level (TL) with respect to total biomass in a given ecosystem (Christensen *et al.*, 2005). In Ecopath, the trophic levels are assigned in two forms. The first method assigns fractional based on approach suggested by Ulanowicz (1995). In this approach TLs are represented as fractions for determining the trophic position of each organism rather than integers as initially proposed by Lindeman. The second method assigns TL in integer form which aggregates the entire system into discrete trophic level (Lindeman, 1942 as cited in Christensen *et al.*, 2005). The second approach is a simplification of the food-web to determine the distribution of net input and output flows in each group that has contributed to the next TL.

The mixed trophic impact routine in EwE can be regarded as a form of ordinary sensitivity analysis (Majkowski, 1982). It is regarded as a tool for indicating the possible impact of direct and indirect interactions (including competition) in a steady-state system,

not as an instrument for making long-term predictions because the changes in abundance may lead to changes in diet composition (Christensen and Walters, 2004).

### **3.12. Network analyses**

The fishery gross efficiency is computed as the ratio between the total catch (landings and discards) and the total primary production in the system. The value is higher for systems with a fishery harvesting mainly in low TLs than for systems whose fisheries concentrate on high TLs. This index may increase with fisheries development as indicated by Pauly *et al.* (1998).

The total system throughput (TST) is defined as the sum of all flows in a system. It represents the size of the entire system in terms of flow (Ulanowicz, 1986). Total system throughput is an important parameter for comparisons of flow networks.

The ratio of total system biomass (B) to the total system throughput (B/tst) (Christensen *et al.*, 2005) is directly proportional to system maturity where estimated value tends to be low during ecosystem development phase and increases as a function of maturity. Energy is conserved through component energy stocking (Odum, 1969). The ratio of net primary production to total respiration is another system maturity index (Odum, 1969) where values of this ratio close to 1 indicate mature ecosystems.

The system omnivory index is computed as the average omnivory index of all consumers weighted by the logarithm of each consumer's food intake (Christensen *et al.*, 2005). The connectance index for a given food web is the ratio of the number of actual links between groups to the number of theoretically possible links. Feeding on detritus (by detritivores)

is included into account. This index is correlated with the maturity of the ecosystem because a food chain structure changes from linear to web-like as a system matures (Odum, 1969).

### 3.13. Ecosim simulations

The Ecosim routine used in EwE is a dynamic simulation approach that uses the linear equations of steady-state Ecopath model (Walters *et al.*, 1997), isolating the biomass accumulation term and setting up differential equations of the form. In Ecosim the Ecopath equation is re-expressed in a dynamic formulation:

$$\frac{\delta B_i}{\delta t} = g_i \sum_j C_{ji} - \sum_j C_{ij} + I_i - (M_i + F_i + e_i)B_i$$

Where  $\frac{\delta B_i}{\delta t}$  represents the biomass growth rate,  $g_i$  is the net growth efficiency (production/consumption ratio),  $\sum_j C_{ji}$  is the total consumption rate of group i,  $\sum_j C_{ij}$  is the predation of all predators on group i,  $M_i$  the non-predation natural mortality rate,  $F_i$  is the fishing mortality rate,  $e_i$  is emigration rate and  $I_i$  is immigration rate. This general equation supports predictions of how biomass develops over time as a consequence of changes in fishing patterns or in other ecosystem forcing functions, e.g., gear effort (Pauly *et al.*, 2000).

Using the mass balanced Ecopath model three Ecosim scenario simulations were run. In all scenarios the simulation time was set to 10 years ahead of the present time. Ecosim requires a vulnerability setting for all predator-prey interactions which controls the rate at which a prey group moves between the vulnerable state and the state in which the group is not susceptible to predation. In this study, the vulnerability of each functional group

was set proportional to its trophic level estimated by Ecopath. This setting has been used in the EwE model (Cheung *et al.*, 2002; Yunkai-Li *et al.*, 2009). Other Ecosim values were set to their default value.

Scenario 1: Changing the mortality of catfish. In this set of runs the fishing mortality of catfish was set to be 1.5 X and 2.0 X. Catfish was chosen because of its deleterious effect that has been seen on the MTI analysis.

Scenario 2: Changing effort of beach seine. In this set of runs the amount of fishing efforts was set to be 0.75, and 0.5 times the current fishing efforts. The choice of beach seine for this scenario is because it acts on wider range of Ecological groups.

Scenario 3: Changing effort of long line. In this set of runs the amount of long line efforts was set to increase by 1.5 and 2.0 times the current fishing efforts. The choice of long line for this scenario is because it only removes catfish which has negative impact on wider range of ecological groups through predation and cascading effect.

## 4. RESULTS AND DISCUSSION

### 4.1. Phytoplankton biomass and production

Phytoplankton species identified during the study period are listed in appendix 1. Phytoplankton biomass, in terms of Chl **a**, varied between 50.18 and 96.38  $\mu\text{g L}^{-1}$  over the study period with mean of 70.46  $\mu\text{g L}^{-1}$ . The average temporal variation of phytoplankton biomass over the study period is shown in Fig. 2. The highest biomass was observed in March while the lowest recorded in December.

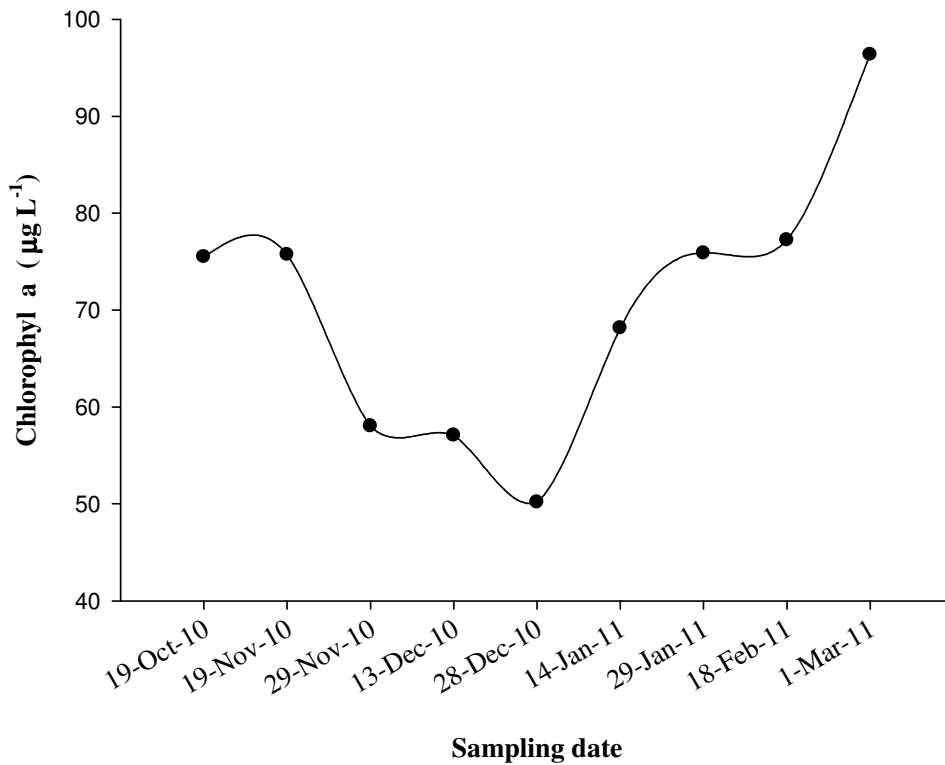

Fig. 2 Temporal variation of Chlorophyll *a* pigments in Lake Ziway

The mean phytoplankton biomass recorded in the present study (70.46  $\mu\text{g L}^{-1}$ ) is higher than those of earlier reports of 43.85  $\mu\text{g L}^{-1}$ , Getachew Beneberu (2004) and 36.4  $\mu\text{g L}^{-1}$  (Girma Tilahun, 2006). Higher levels of Chl *a* measured in the present study (96.38  $\mu\text{g L}^{-1}$ )

L<sup>-1</sup>) were not recorded during seasonal studies covering the period 2004-2006 (Getachew Beneberu, 2004; Girma Tilahun, 2006). The maximum value reported during the period was 57.5 µg L<sup>-1</sup> (Girma Tilahun, 2006). However the current result is comparable to the study made in 1990-2000 by Zinabu Gebremariam *et al.* (2002) measuring a mean of 82.4 varying between 23-224 µg L<sup>-1</sup>.

The current mean Chl *a* of 70.46 µg L<sup>-1</sup> is converted to wet weight (WW) so as to fit the unit of Ecopath model and was estimated to be 15.99 tons WW km<sup>-2</sup>. The value was obtained using the subsequent conversion of Chl *a* to carbon and then carbon to WW (Jones, 1979). The mean euphotic depth of 0.54 m (estimated from the mean Secchi disk depth 0.18 m) was used to convert the volumetric value to areal biomass.

Girma Tilahun and Ahlgren (2009) estimated primary production for Lake Ziway employing C<sup>14</sup> method and the hourly integral rates of 1.06 g C m<sup>-2</sup> d<sup>-1</sup> was used to determine P/B ratio for the present study. Yearly primary production of 3869 g WW m<sup>-2</sup> year<sup>-1</sup> was obtained after appropriate conversion and multiplication factor. Based on the mean biomass of 15.99 tons km<sup>-2</sup>, annual Production/biomass ratio of 241.96 was calculated.

Despite its high productivity, the wet weight phytoplankton biomass of Lake Ziway is less than that of Lake Awassa (34.45 tons km<sup>-2</sup>, Tadesse Fetahi and Seyoum Mengistou, 2007) and this could be due to the thin euphotic depth of Lake Ziway. The abiogenic turbidity of the lake has increased significantly in recent decades (Girma Tilahun, 2006).

## 4.2. Zooplankton

### 4.2.1. Zooplankton abundance and biomass

Zooplankton of Lake Ziway during the study period includes two copepods, four cladoceras and eighteen rotifers (Table 2). In the current study, previously reported cyclopoid species *Afrocylops gibsoni* and the cladocera *Alona diaphana* were not recorded. The absence of *Afrocylops gibsoni* might be due to their low abundance which only contributed less than 0.1 % of the crustacean abundance (Adamneh Dagne *et al.*, 2008) The number of rotifer species identified in this study (Table 2) was much less than that of Adamneh Dagne *et al.* (2008) who reported the presence of 49 species. This might resulted from the opportunistic behavior of rotifers.

Table 2 List of zooplankton species in Lake Ziway

Cladoceras	Copepods	Rotifers
<i>Moina micrura</i>	<i>Mesocyclops aequatorialis</i>	<i>Anuraeopsis sp.</i>
<i>Diaphanosoma excisum</i>	<i>Thermocyclops decipiens</i>	<i>Asplanchna sp.</i>
<i>Daphnia barbata</i>		<i>Brachionus angularis</i>
<i>Ceriodaphnia cornuta</i>		<i>B. caudatus</i>
		<i>B. quadridentatus</i>
		<i>Brachionus sp.</i>
		<i>Filinia sp.</i>
		<i>Keratella tropica</i>
		<i>Lecane sp.</i>
		<i>Polyarthra sp.</i>
		<i>Trichocerca sp.</i>

The copepods contributed 38.84% on average to monthly total zooplankton abundance throughout the sampling period, while the contribution of rotifers was 56.14%. The contribution of cladocerans was only 5.01%. The proportion of copepods was lowest in January, with the contribution of 14%. Among rotifers *Brachionus angularis*, *B. caudatus*, *Keratela tropica*, and *Filinia sp.* were dominant throughout the study period. The zooplankton community of Lake Ziway was dominated by rotifers, in terms of abundance (125 rotifers L<sup>-1</sup> with a peak of 302 ind. L<sup>-1</sup> in mid January). The maximum zooplankton density were also recorded in same month (371 ind. L<sup>-1</sup>). The minimum zooplankton number (76 ind. L<sup>-1</sup>) occurred in mid October with 42% contribution of rotifers. High number of rotifers (>1000 ind. l<sup>-1</sup> per single species of *Anuraeopsis fissa*) recorded by Adamneh Dagne *et al.* (2008) were not observed in the current study which might resulted from difference on sampling period.

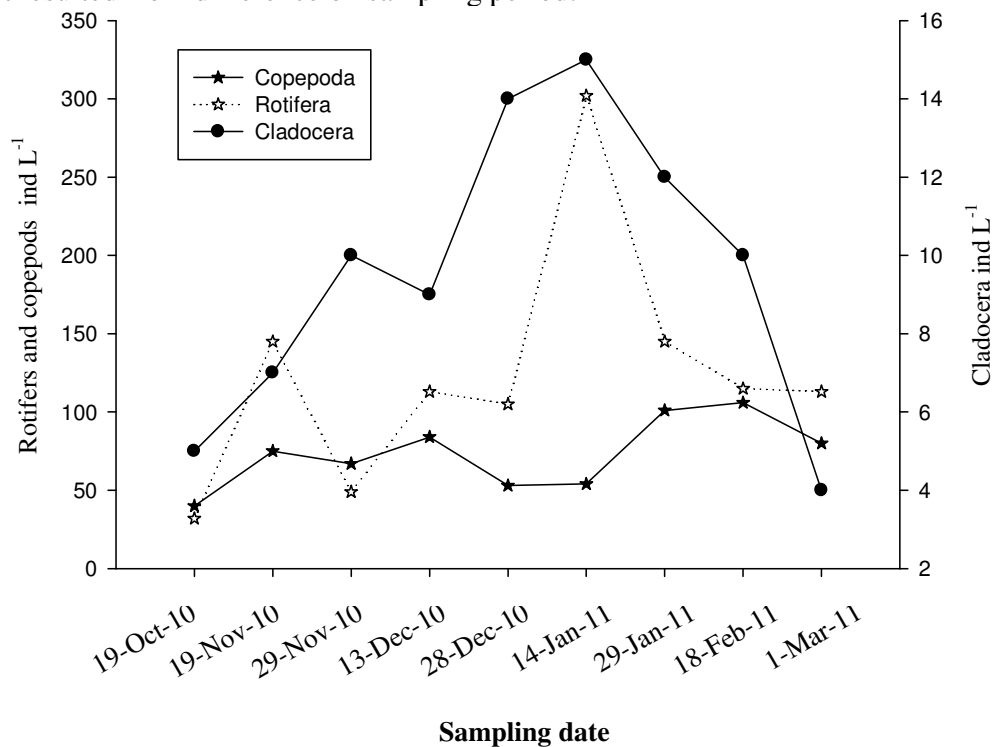

Fig. 3 Temporal variations in zooplankton community of Lake Ziway

The current data on biomasses of zooplankton in Lake Ziway are compiled in Table 3. The contribution of rotifers to the total biomass was only 10.89%, with a maximum contribution in mid January having a biomass value of 77.84 WW mg m<sup>-3</sup> amounting 16.61%. Adult *Thermocyclops decipiens* alone contributed 31.96 % of the total biomass. For Ecopath analysis, a biomass value of 0.017 and 0.97 WW tons km<sup>2</sup> was used for carnivore zooplankton and herbivore zooplankton respectively based on a recent annual study by Adamneh Dagne (2010).

Table 3 Biomass of Zooplankton species in Lake Ziway during the sampling period between October 2010 and March 2011

Species	Biomass WW mg m <sup>-3</sup>
<i>Ceriodaphnia cornuta</i>	15.38
<i>Daphnia barbata</i>	3.47
<i>Diaphanosoma excisum</i>	25.99
<i>Moina micrura</i>	91.99
<i>Mesocyclops aequatorialis</i>	8.40
<i>Thermocyclops decipiens</i>	127.73
Cyclopoid nauplii	69.62
Cyclopoid Copepodites	7.57
Sum of Rotifers	43.52

#### 4.2.2. Production/biomass ratio

Production/biomass ratio was estimated based on the production value of zooplankton calculated by Adamneh Dagne (2010). Production value of 510.1 mg DW m<sup>-3</sup> was estimated for the dominant cladocera *Moina micrura*. While the production values for adult *Thermocyclops*, Adult *Mesocyclops*, nauplii and Copepodites were 41.2, 4, 1206.4 and 1441 mg DW m<sup>-3</sup> respectively. In the present study, *Thermocyclops aequatorialis*

was considered as carnivorous zooplankton and the rest of the group as herbivorous zooplankton resulting in a production/ biomass ratio of 38.35 and 272.8, respectively

#### **4.2.3. Consumption/biomass ratio**

Consumption biomass ratio (Q/B) of zooplankton was estimated based on assumed gross food conversion efficiency (P/Q) of 0.2 (Pauly *et al.*, 1993) which gave  $191.75 \text{ year}^{-1}$  and  $1364 \text{ year}^{-1}$  for carnivore and herbivore zooplankton, respectively.

### **4.3. Macro-zoobenthos**

#### **4.3.1. Abundance and biomass**

A total of fourteen families of benthic macroinvertebrates were recorded (Appendix 2). The littoral community in the lake was dominated by Chironomidae ( $15924 \pm 5976 \text{ SE}$  individuals  $\text{m}^{-2}$ ) which are attached mainly with the Macrophyte *Thypa angustifolia*. The chironomids were mainly represented by species of *Chironomus spp.*, *Dicrotendipes spp.* and *Microchironomus spp.*

The abundance of chironomids within the pelagic zone is lower than that of the littoral with a total population of ( $945 \pm 78 \text{ SE}$  individual's  $\text{m}^{-2}$ ). Ephemeropterans were represented mainly by Potamanthidae ( $44 \pm 17 \text{ SE}$  individual's  $\text{m}^{-2}$ ) within the littoral zone. Molluscs were largely represented by gastropods, mainly *Biomphalaria sudanica* within the littoral zone while the pelagic gastropods constitute the bivalve Corbiculidae. Macro-zoobenthos collected from the macrophyte dominated littoral zone belonged to the order and (families) of Hemiptera (Corixidae); Ephemeroptera (Baetidae and Caenidae); Odonata (Coenogriidae); Lepidoptera (Psychodidae); Coleoptera (Elmidae) and Diptera (Ceratopogonidae).

The macro-zoobenthic biomass in Lake Ziway is dominated by Dipterans, Ephemeropterans and bivalves each contributing 18.6%, 13.39% and 13.01% respectively, to the total macro-zoobenthos biomass. The distribution of the biomass among the main macro-zoobenthic groups within the pelagic zone is illustrated in Fig. 4. The mean biomass of macro-zoobenthos within the macrophyte vegetation is 246.35 g WW m<sup>-2</sup> and 9.4 g WW m<sup>-2</sup> for the pelagic zone. A biomass value of 23.62 g WW m<sup>-2</sup> was estimated for the whole lake.

#### 4.3.2. Production/biomass ratio

Production/biomass ratio of benthic macro-invertebrates was estimated using the empirical formula of Plante and Downing (1989). Production was estimated based on an average of 12 samples from macrophyte dominated zone and 15 samples from pelagic zone. Production was higher in macrophyte dominated zone (littoral habitats) with value of 122.77 year<sup>-1</sup> compared to 9.84 year<sup>-1</sup> for pelagic zone. Production biomass of 16.62 year<sup>-1</sup> was estimated for the whole lake

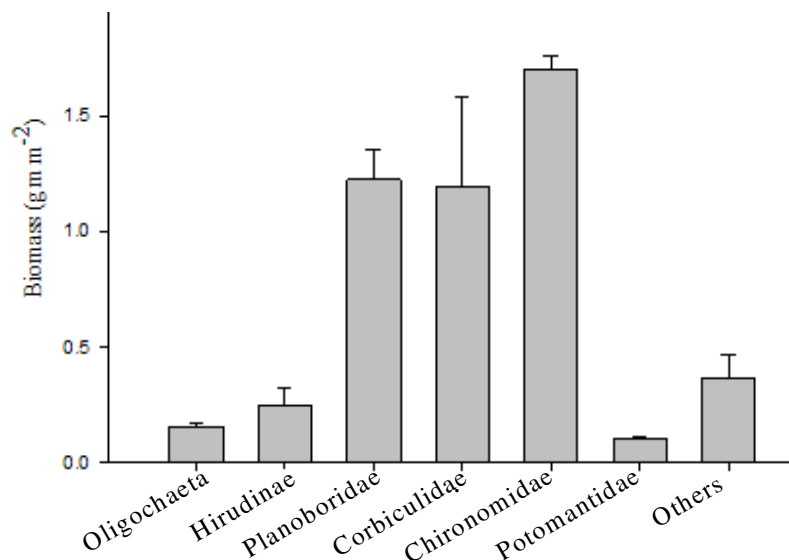

Fig. 4 Distribution of macro-zoobenthos families' biomass in Lake Ziway

#### **4.3.3. Consumption/biomass ratio**

Consumption /biomass ratio of 83.1 year<sup>-1</sup> was computed for macro-zoobenthos based on assumed gross food conversion efficiency (P/Q) of 0.2 (Pauly *et al.*, 1993).

#### **4.4. Macrophytes**

The macrophyte vegetation of Lake Ziway includes *Typha angustifolia*, *Arunda olonax*, *Echinochola colona*, *Potamogeton lucenus* and *Nymphaea lotur*. Distribution of *Typha angustifolia* was mainly restricted to western and north western side of the lake while *Arunda olonax* and *Echinochola colona* were distributed in all sides of the lake. The above ground fresh weight biomass of macrophyte estimated from three localities was 3011.68 tons WW km<sup>-2</sup>. Macrophyte areal distribution was estimated to be six percent of the lake from a satellite map. Based on this value a macrophyte biomass value of 180.7 tons WW km<sup>-2</sup> was used as an input for the Ecopath analysis. The value was comparable with other African lakes which have a macrophyte biomass of 187.8 tons WW km<sup>-2</sup> (Lake Kariba, Machena *et al.*, 1993) and 170.4 tons WW km<sup>-2</sup> (Lake Naivasha, Mauti *et al.*, 1996).

#### **4.5. Detritus biomass**

Euphotic depth of 54 cm was calculated from mean Secchi disk depth of 18 cm. The detritus biomass (6.72 g WW m<sup>-2</sup>) was estimated using the empirical relationship of Christensen and Pauly (1993). The detrital biomass of Lake Ziway was much less than Lake Awassa (63.79 g WW m<sup>-2</sup>) (Tadesse Fetahi and Seyoum Mengistou, 2007) but comparable to Lake Aydat (France) which has a detrital biomass of 5 g WW m<sup>-2</sup> (Reyes-Marchant, 1993).

## 4.6. Fisheries

### 4.6.1. Biomass of commercially exploited and non-exploited fish

The fishing activity of Lake Ziway is operated by three types of gears: beach seine, gillnet and long line. The total annual catch from Lake Ziway was estimated as 1127 tons per year (2008–2010) using catch and effort data as inputs. The value of total yield was categorized into the respective functional groups. Based on the calculated fishing mortality of each group, biomass value of 0.27, 1.28 and 1.09 tons km<sup>-2</sup> was calculated for carp, tilapia and catfish, respectively.

The estimated mean annual catch in tons per gear type was 683.11, 62.97 and 295.98 for beach seine, gill net and long line, respectively (Fig. 5). Long line in Lake Ziway catches only Catfish. The current annual yield of Lake Ziway fishery is much less than the previous estimates. Felegeselam Yohannes (2003) reported the average total annual catch in Lake Ziway was 2459.25 tons between 1986 and 1993 E.C, with a range of 2105-3180 tons per year.

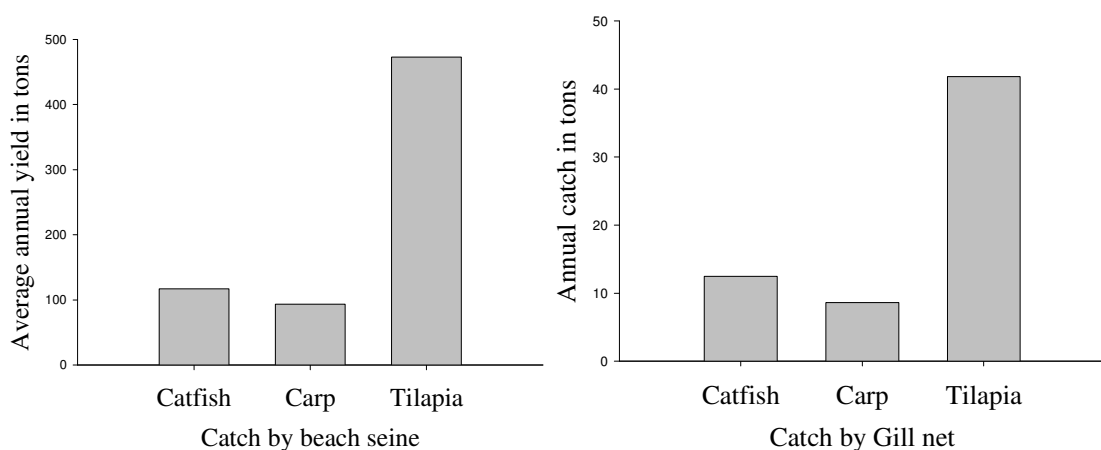

Fig. 5 Annual catch of fish by Beach seine and gill net in Lake Ziway between year 2008 and 2010

#### 4.6.2. Production/biomass ratio

Based on the length frequency data, the Von Bertalanffy Growth Function ( $K$ ) was calculated (Table 4). Production/biomass ratio was equivalent to total mortality ( $Z$ ) (Allen, 1971) and  $Z$  was estimated for Carp and Catfish with value of 0.74 and 1.34 per year, respectively. The total mortality of 1.93 per year for Tilapia was taken from Gashaw Tesfaye (2006). Total mortality of 2.54 and 2.49 per year was computed for Garra and Barbus group, respectively based on the Von Bertalanffy Growth function ( $K$ ) of 1.5 taken from Lake Awassa (Tadesse Fetahi and Seyoum Mengistou, 2007).

Table 4 Growth and other fish parameters used for estimation of consumption biomass

<b>Growth parameters</b>	<b>Tilapia</b>	<b>Catfish</b>	<b>Carp</b>	<b>Garra</b>	<b>Barbus</b>
<b><math>L_{\infty}</math> (cm)</b>	31.5	100.8	49.4	10.9	11.4
<b><math>K</math> (<math>y^{-1}</math>)</b>	0.43	0.22	0.19	1.5	1.5
<b>Aspect ratio</b>	1.73	1.63	2.1	3.25	3.78
<b><math>h</math></b>	1	0	1	0	0
<b><math>d</math></b>	0	0	0	0	0

$L_{\infty}$ = asymptotic fish length,  $K$ = The von Bertalanffy growth function,  $A$ = aspect ratio,  $h$  = a dummy variable expressing food type (1 for herbivores, and 0 for detritivores),  $d$ = dummy variable also expressing food type (1 for detritivores and 0 for herbivores)

#### 4.7. Model output

Biomass estimates, diet compositions, and catch yields were left largely unchanged during model balancing as these parameters were directly estimated from Lake Ziway. The data for this model was assigned an Ecopath Pedigree Index of 0.58, demonstrating the model represents the system. The basic input values used for Ecopath analysis are presented in Tables 5 and 6.

Table 5 Input values used for the Ecopath model of Lake Ziway

Functional groups	Biomass (t/km <sup>2</sup> )	P/B year <sup>-1</sup>	Q/B year <sup>-1</sup>
Waterfowls	0.00300	0.250 <sup>a</sup>	58.000 <sup>a</sup>
Cat fish	1.090	1.340	5.970
Carp	0.270	0.740	22.550
Tilapia	1.280	1.93 <sup>b</sup>	28.40
Barbus	0.120	2.490	24.410
Garra	0.0800	2.540	21.990
Macro-zoobenthos	23.620	16.620	83.100
Carnivores zooplankton	0.0170 <sup>c</sup>	38.350 <sup>c</sup>	191.750
Herbivores zooplankton	0.970 <sup>c</sup>	272.800 <sup>c</sup>	1364.00
Phytoplankton	15.990	241.960	
Macrophyte	3011.680		
Detritus	6.720		

<sup>a</sup> Moreau *et al.* (1993); <sup>b</sup> Gashaw Tesfaye (2006); <sup>c</sup> Adamneh Dagne (2010)

Table 6 Diet compositions of the functional groups in Lake Ziway ecosystem model

No	Prey	Predator								
		1	2	3	4	5	6	7	8	9
1	Waterfowls <sup>a</sup>									
2	Cat fish <sup>b</sup>									
3	Carp	0.0								
4	Tilapia <sup>c</sup>	0.7	0.150							
5	Barbus	0.2	0.050							
6	Garra	0.0								
7	Macro-zoobenthos <sup>d</sup>		0.200	0.100		0.580	0.850	0.08	0.100	0.080
8	Carnivores zooplankton <sup>e</sup>		0.050	0.010				0		
9	Herbivores zooplankton <sup>e</sup>		0.450	0.300	0.020	0.250	0.050	0.06	0.680	
10	Phytoplankton			0.440	0.760	0.150		0.31	0.120	0.850
11	Macrophyte				0.200			0		
12	Detritus		0.100	0.150	0.020	0.020	0.100	0.55	0.100	0.070

<sup>a</sup> Moreau *et al.* (1993); <sup>b</sup> Daba Tugie and Mesert Taye (2004); <sup>c</sup> Alemayehu Negassa and Padanillay (2008). ; <sup>d</sup> Mavuti *et al.* (1996); <sup>e</sup> Tadesse Fetahi and Seyoum Mengistou (2007)

#### 4.8. Trophic structure and biomass flow

Ecopath model assigns fractional trophic levels to each trophic box using the weighted average of the trophic levels (TLs) of each prey item. TLs of the functional groups in Lake Ziway ecosystem were calculated between 1.0 and 3.29 (Table 7).

Table 7 Balanced parameters of Lake Ziway used to run Ecopath with Ecosim

Functional groups	Trophic level	Biomass (t/km <sup>2</sup> )	P/B year <sup>-1</sup>	Q/B year <sup>-1</sup>	EE	P/Q
Waterfowls	3.29	0.0024	0.25	58.00	0.00	0.004
Cat fish	3.07	0.872	1.34	5.97	0.84	0.22
Carp	2.46	0.322	0.74	22.55	0.99	0.03
Tilapia	2.02	1.280	1.93	28.40	0.84	0.07
Barbus	2.94	0.120	2.49	24.41	0.97	0.10
Garra	3.04	0.080	2.54	21.99	0.05	0.12
Macro-zoobenthos	2.16	21.258	16.62	83.10	0.75	0.20
Carnivores zooplankton	2.86	0.017	38.35	191.75	0.51	0.20
Herbivores zooplankton	2.09	1.067	272.80	1364.00	0.39	0.20
Phytoplankton	1.00	15.990	241.96	0.00	0.47	-
Macrophyte	1.00	180.701	0.29	0.00	0.02	-
Detritus	1.00	6.720	-	-	0.32	-

The top predators were water fowls (TL = 3.29) followed by catfish (TL = 3.07). The functional group Garra and Barbus have TL values greater than 2.90 due to their carnivores type of feeding on macro-zoobenthos and zooplankton, respectively. The other commercially important fish groups, Tilapia and Carp have TL of 2.02 and 2.46, respectively. From the fisheries point of view trophic levels in the system, the maximum

fishery TL is 3.07, while the mean of the total fishery catch is at trophic level of 2.49. The mean TL of Lake Ziway is comparable to Lake Awassa and Lake Hayq which have a mean trophic level of 2.57 (Tadesse Fetahi and Seyoum Mengistou, 2007); and 2.46 (Tadesse Fetahi *et al.*, 2011) respectively. The similarity in TL could be associated with the resemblance in species composition and preference of the fisheries on Tilapia. As The Carp group (*Carassius carassius* and *Carassius auratus*) and *Clarias gariepinus* are exotic to Lake Ziway (Golubtsov *et al.*, 2002), but having higher trophic levels in the system indicated that they have contributed to increment in material cycle within the system.

The trophic level aggregation into discrete trophic levels of Lindeman spine for Lake Ziway ecosystem is given in Fig. 6. The flow revealed that the system is phytoplankton dominated which contribute 62.9 % of the total biomass flow originating from first trophic level followed by detritus which contribute 37.1 %.

In Lake Ziway ecosystem the biomass flow was highly restricted to I and II trophic level as they contribute 99.76 % of flow while the role of trophic level IV and V were less than 0.1% (Appendices 4). The energy transfer at lower trophic level in Lake Ziway is much less than other productive African lakes (Christensen and Pauly, 1993). The trophic efficiency at trophic level II was 19.99 % at Lake Hayq (Tadesse Fetahi *et al.*, 2011) and 16.9% at Lake Malawi (Degnbol, 1993) while the value was only 0.9% at Lake Ziway. The low value of transfer efficiency (TE) from TL II in this system might have resulted from the large exploitation at TL II, which became the main part of the Lake fishery. The low Ecotrophic efficiency (0.39) of herbivores zooplankton, which is the main

component of the second trophic level in Lake Ziway (Appendices 4) have also contributed in low efficiency of the energy transfer. As can be seen from the Lindeman cycle (Fig 6) larger proportion of material flows at TL II were to detritus. Similar situation in which zooplanktons (cyclopoid copepods) acting as a sink rather than link in Lake Ecosystem has also been observed in Lake Hayq (Tadesse Fetahi *et al.*, 2011).

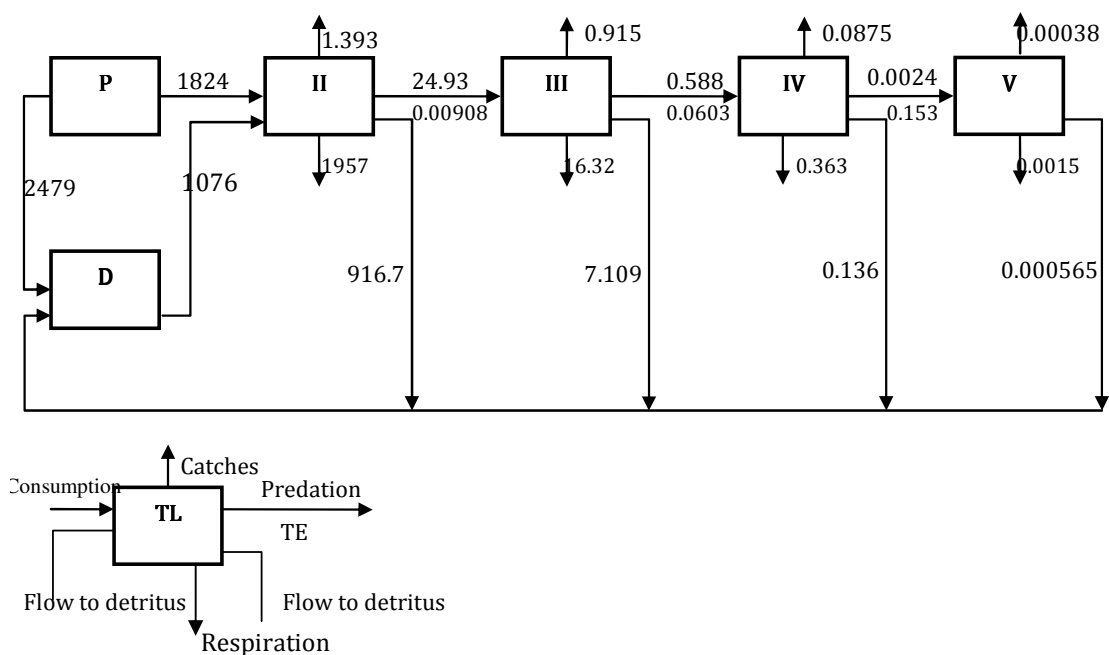

Fig. 6 The aggregation of the flows ( $\text{tkm}^{-2}\text{year}^{-1}$ ) into a connected chain of transfers

The increment in TE at TL III and IV might be attributed to effective utilization of macro-zoobenthos in the lake ecosystem. The introduction of *Clarias gariepinus*, *Carassius carassius* and *Carassius auratus* has definitely improved energy TE in the lake as their feed is dominated on those groups that are acting as a sink in the lake ecosystem. Similarly, the energy transfer efficiency of Lake Kivu has increased following the introduction of exotic fish species (Villanuevaa, 2008). The efficiency has also increased

in Lake Victoria after the introduction of Nile perch (Moreau *et al.*, 1993). The stocking of Tilapia in Lake Hayq, Ethiopia has also contributed for higher transfer efficiency from primary production to fish yield (Tadesse and Seyoum, 2011). Hence, introduction could be beneficial if done after appropriate study (fish ecology including feeding nature and growth, limnological/environmental requirements etc).

The mean TE of Lake Ziway was 4.4% which was less than Lake Nakuru (8%, Moreau *et al.*, 2001), Lake Tahi (6.9%, Yunkai-Li *et al.*, 2010) and Lake Awassa (14.2%, Tadesse Fetahi and Seyoum Menigistu 2007). The overall low TE in Lake Ziway might be attributed to the low efficient utilization of the first three trophic levels, due to low diversity of specialized fish group. This phenomenon might have resulted from the absence of feed specialization which was observed in this ecosystem and explained by system omnivore index of 0.20.

Table 8 Transfer efficiency of aggregated trophic levels in Lake Ziway

Source \ TL	II	III	IV	V
Producer	0.8	7.9	15.5	-
Detritus	1.0	3.6	14.8	15.8
All flows	0.9	6.0	15.3	15.8
Proportion of total flow originating from detritus: 0.42				
Transfer efficiencies (calculated as geometric mean for TL II-IV)				
From primary producers: 4.7%				
From detritus: 3.8%				
Total: 4.4%				

The fishery catch consumed 2.5% of the primary production in the lake, out of which 1.45 % was predated by Catfish. From the total detritus formed annually, 1076 t km<sup>-2</sup> year<sup>-1</sup> was consumed in the system, while the remaining 1327 tons km<sup>-2</sup> year<sup>-1</sup> was exported to the sediments. The total fish biomass density obtained from the Lake Ziway ecosystem model was 2.67 tons km<sup>-2</sup>, while the exploited groups have a biomass of 2.52 tons km<sup>-2</sup>. The value of the exploitable fish biomass is much less than other Ecopath modeled Ethiopian lakes which have a biomass of 4.8 tons km<sup>-2</sup>, for Lake Hayq (Tadesse Fetahi *et al.*, 2011) and 12.08 tons km<sup>-2</sup> year<sup>-1</sup> for Lake Awassa (Tadesse Fetahi and Seyoum Mengistou, 2007). The current harvestable fish biomass of Lake Ziway is in close agreement to the MSY predicted at 1011 tons year<sup>-1</sup> (2.33 tons km<sup>-2</sup> year<sup>-1</sup>) by Felegeselam Yohannes (2003).

The trophic structure and biomass flow from primary producer (including detritus) is assembled in Fig. 7. The total matter flow in the system has a path length of 75 with mean path length of 3.71. From the harvested fish groups in Lake Ziway Ecosystem Catfish and carp have the longest pathways each with 17 and 10 pathways of energy flow originating from phytoplankton, while it was only 3 pathways for Tilapia. The phenomenon indicates that the introduction of these two groups into the lake ecosystem has increased the conectance index to 0.31.

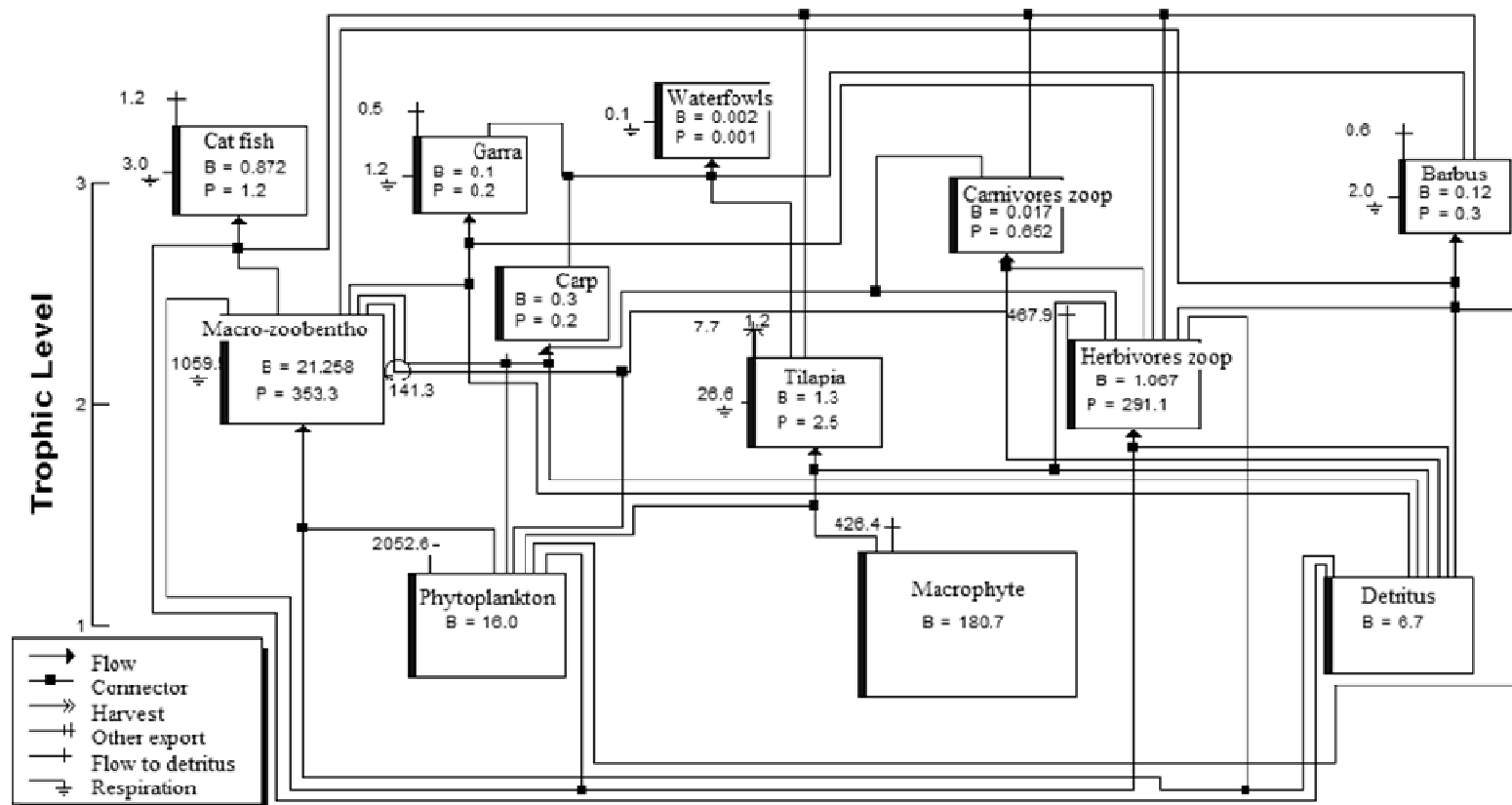

Fig. 7 Graphic representations of trophic structure and biomass flow in Lake Ziway ecosystem.

B = Biomass and P = Production Food Flows are expressed in tons km<sup>-2</sup> year<sup>-1</sup>.

#### 4.9. Mixed trophic impact (MTI) analysis

Trophic interaction between functional groups was given in Fig. 9. MTI analysis shows the direct and indirect impacts of a slight increase in the biomass of each group on the biomass of the other groups (Majkowski, 1982). Macro-zoobenthose and catfish have negative impact on wider range of groups, as they were widely interconnected to other groups trophically. The impact of carnivore zooplankton and Garra was low compared to other functional group in the system. In all systems, functional groups respond negatively to an increase in their own biomass, probably due to an increase in competition within the functional group (Christensen *et al.*, 2005). Phytoplankton and detritus had the highest positive impacts on other groups in the system (Fig. 8), providing an important food source for the other groups. Talling and Lemoalle (1998) observed from their studies that the primary producers have a positive effect in all other biological groups.

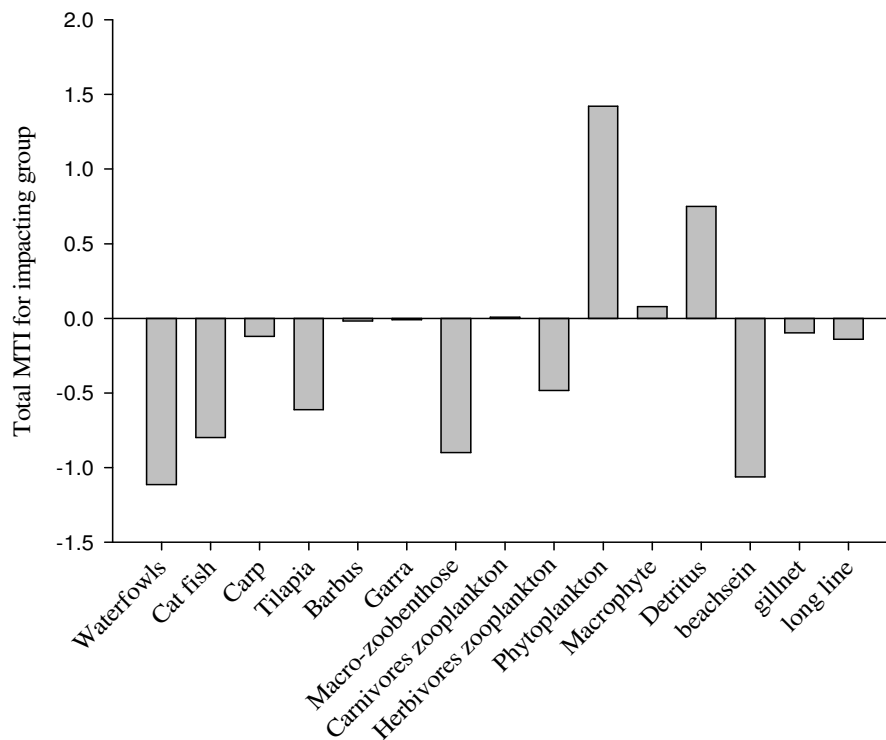

Fig. 8 Total MTI of each impacting group on the Lake Ziway ecosystem

The fishing gears operating in the lake were also included in the mixed trophic impact routine. Based on cumulative impact of functional groups on ecosystem (Fig. 8), the beach seine fishery has the most cumulative impact on the ecosystem. This phenomenon has shown the deleterious impact of beach seine on the ecosystem in general, by being non specific to a targeted species. The impact of long line fishery on the ecosystem is minimal because it removes only the catfish group, a group which has wider negative ecosystem level impact (Fig. 9). In Lake Ziway, mixed trophic impact analysis showed that fishing pressure by beach seine had more negative impact on the functional groups considered in this study as compared with predation and competition.

The role of biodiversity has been hypothesized as insurance to ecosystem functioning in case of modifications (Loreau *et al.*, 2001). Species introduction can affect biodiversity either by global homogenization of regional biota or by affecting native species functions (Levine *et al.*, 2003). However introduction can also play a crucial role in enhancing the fishery potential (Welcomme, 1988) if done properly by studying the available open niche and simulating different scenarios. Lake Ziway is low in its biodiversity in terms of fishery unlike the southern rift valley lakes (Lake Chamo and Lake Abaya) (Eshete Dejen *et al.*, 2010) and other Great lakes of Africa (Villanueva *et al.*, 2008). This phenomenon indicates that a small perturbation on fishery could affect the ecosystem in general as higher biodiversity is related to stability (Loreau *et al.*, 2001).

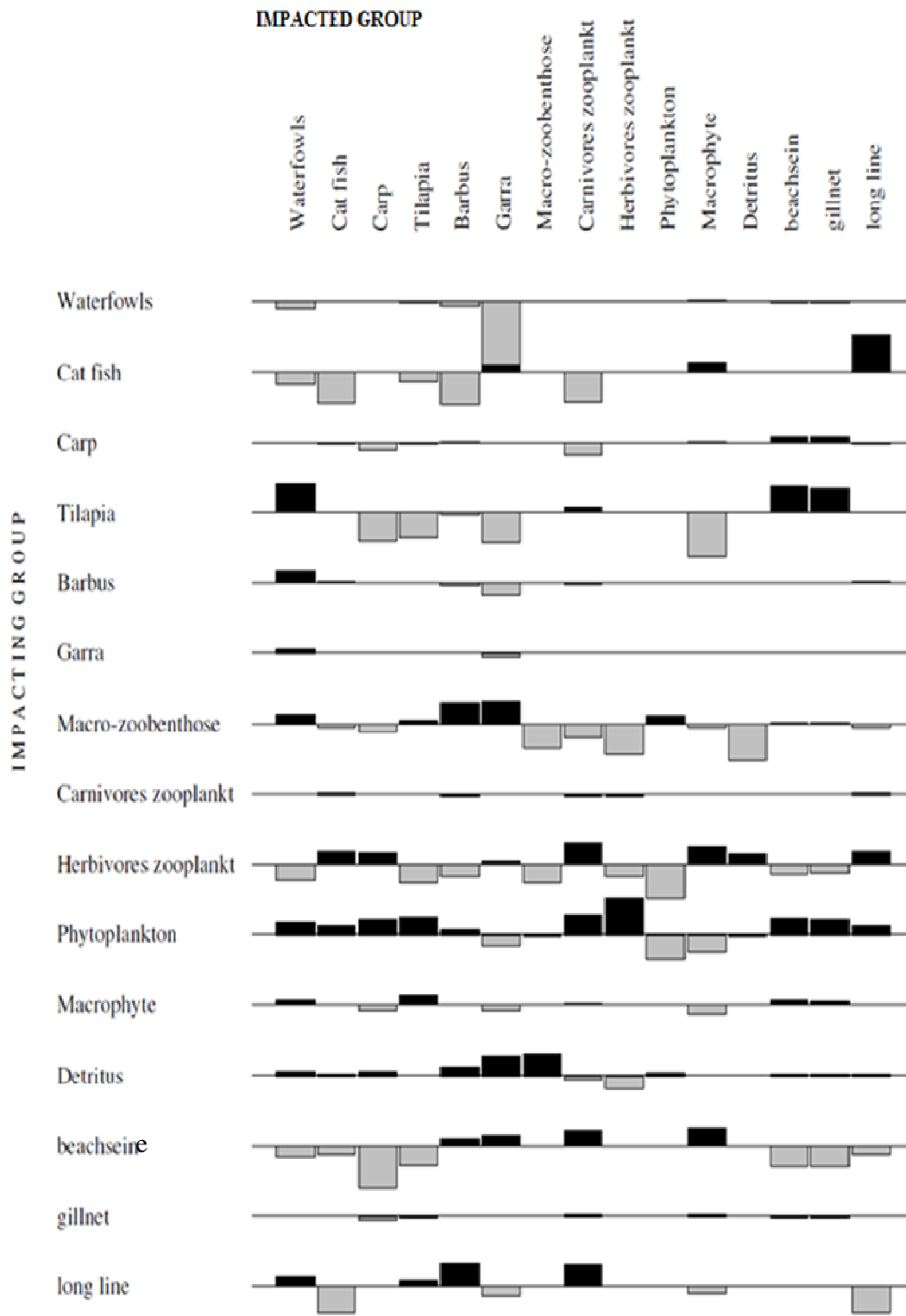

Fig. 9 MTI of Lake Ziway Ecosystem

#### **4.10. Ecotrophic Efficiencies (EE)**

A low EE value of 0.47 has been calculated for the phytoplankton indicating that most of the production remains within the system unutilized. The EE value of phytoplankton for Lake Ziway is relatively higher than Lake Awassa 0.114 (Tadesse Fetahi and Seyoum Mengistou, 2007); However it is much lower than that of Lake Hayq (0.8) (Tadesse Fetahi *et al.*, 2011). The lower value may be attributed to the limited quantity of fish and other functional groups basically consuming this group despite its high Production/biomass ratio of 241.94 year<sup>-1</sup>.

Relatively higher values of EE were calculated for carp, barbus and macro-zoobenthose with a value of 0.99, 0.97 and 0.75, respectively. This indicated that despite its low biomass, carp is subjected to high fishing pressure and there is less additional room for the introduction of zoo-benthic feeder in the system. However, there is still open room for planktivores (both zooplankton and phytoplankton) as they have low EE value and contributing most of their production to the detrital pool than being transferred to higher trophic level. EE value of the other fish groups is also higher except that for Garra, which has quite low EE value of 0.05, suggesting a very limited predation in the lake. In Lake Ziway, EE values were high for all fish groups, indicating that they were highly constrained by combination of fishing and predation.

#### 4.11. Summary statistics

Ecosystem attributes which describes Lake Ziway ecosystem is summarized in Table 9 and 10. Total system throughout of Lake Ziway ecosystem was dominated by detritus which contribute 30.98% followed by consumption 29.85%. The production to respiration ratio of 2.18 as well as the 2328.97 t km<sup>-2</sup> year<sup>-1</sup> of the net system production (i.e., the difference between total primary production and total respiration) are indicative of the Lake Ziway's ability to sustain without allochtonus subsidies of organic matter from the watershed.

According to Odum (1969), the ratio between primary production and total system respiration (PP/R) would decline to 1.0 as an ecosystem develops toward maturity. Biomass accumulates as the system develops, thus lead to a lower ratio between primary production and biomass (PP/B). The PP/R of Lake Ziway ecosystem was 2.18, times larger than 1.0 of mature systems. The PP/B ratio of Lake Ziway (19.40) is greater than Lake Awassa which has a PP/B ratio of 5.67 (Tadesse Fetahi and Seyoum Mengistou 2007) indicating that it is less mature. The above two feature suggested that the Lake Ziway ecosystem is still an immature ecosystem and in a developing stage.

Table 9 Primary production required (PPR) for the catch group of Lake Ziway ecosystem

Group name	No. of paths	PPR (PP)	PPR (Det)	PPR	Catch	PPR/catch	PPR/TotPP(%)	PPR/ u. catch
<b>Cat fish</b>	36	81.37	30.10	111.47	0.98	113.64	1.45	0.01
<b>Carp</b>	20	42.29	16.55	58.84	0.23	250.38	0.76	0.03
<b>Tilapia</b>	7	21.26	1.97	23.24	1.19	19.60	0.30	0.00
<b>Total</b>	63	144.92	48.62	193.54	2.40	80.60	2.51	0.01

Where PP= primary production      Det= Detritus

Fish productivity is linked to primary production by different intermediate trophic links. The primary production required in order to support the fishery is 2.51% of the total primary production (Table 9). The value is very low compared to an average value suggested by Pauly and Christensen (1995) for tropical lakes and rivers (23.6%).

Table 10 Ecosystem indicators describing Lakes Ziway, Awassa and Hayq ecosystem structures

Parameter	Ziway	Awassa <sup>a</sup>	Hayq <sup>b</sup>	Unit
Sum of all consumption	3278.834	2151.517	21492.980	t km <sup>-2</sup> year <sup>-1</sup>
Sum of all exports	2328.973	10649.21	43.539	t km <sup>-2</sup> year <sup>-1</sup>
Sum of all respiratory flows	1973.65	1204.062	10062.830	t km <sup>-2</sup> year <sup>-1</sup>
Sum of all flows into detritus	3402.943	11328.46	8085.361	t km <sup>-2</sup> year <sup>-1</sup>
Total system throughput	10984.4	25333	39685.00	t km <sup>-2</sup> year <sup>-1</sup>
Sum of all production	4952.041	12370	17857.00	t km <sup>-2</sup> year <sup>-1</sup>
Mean trophic level of the catch	2.491786	2.57	2.46	
Gross efficiency (catch/net p.p.)	0.00055811	0.0001018	0.000475	t km <sup>-2</sup> year <sup>-1</sup>
Calculated total net primary production	4302.623	-	-	t km <sup>-2</sup> year <sup>-1</sup>
Total primary production/total respiration	2.180034	9.84	1.004	t km <sup>-2</sup> year <sup>-1</sup>
Net system production	2328.973	10649.21	-	
Total primary production/total biomass	19.40659	5.673	100.974	
Total biomass/total throughput	0.02018403	0.082	-	
Total biomass (excluding detritus)	221.7094	-	-	t km <sup>-2</sup> year <sup>-1</sup>
Total catches	2.401356	-	-	t km <sup>-2</sup> year <sup>-1</sup>
Connectance Index	0.3057851	-	0.214	
System Omnivory Index	0.146178	-		

<sup>a</sup>Tadesse Fetahi and Seyoum Mengistou (2007) <sup>b</sup>Tadesse Fetahi *et al.* (2011).

The Gross efficiency value of 0.000558 is greater than Lake Awassa (Table 10), however its comparable to other East African Lake Ihema 0.0007 (Mavuti *et al.*, 1996).

#### 4.12. Ecosim output

The first scenario of increasing catfish mortality rate by 1.5 X resulted in increment of Tilapia group to 1.6 times the current biomass in four years period and leveling of its biomass to 1.16 times the current value at the end of the tenth year (Fig. 10). This also decreased the biomass of tcatfish to 0.29 times the current biomass.

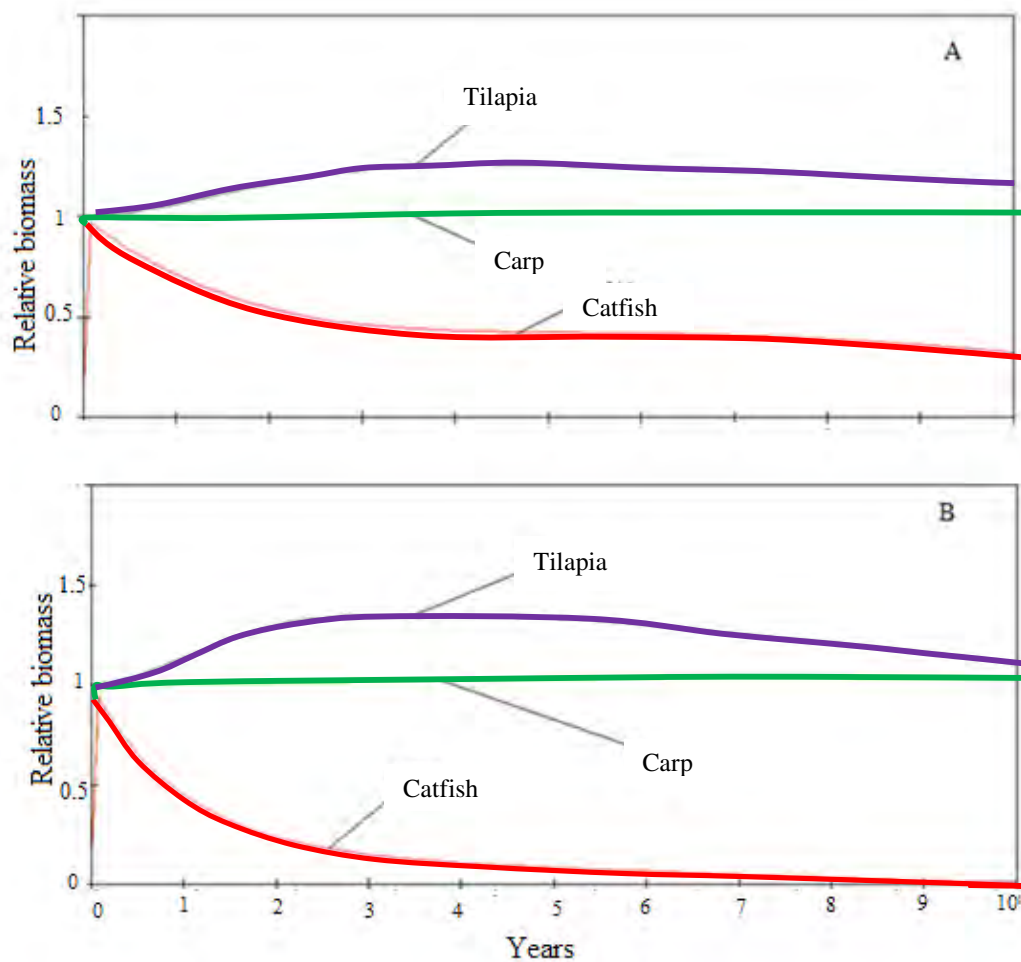

Fig. 10 Relative changes in biomass associated with increasing the mortality of catfish to 1.50 times (A) and 2.00 times (B).

The doubling increment in mortality of catfish resulted in increment of tilapia biomass to only 1.12 times the current biomass but significantly decreased the biomass of catfish from leaving only 0.021 times the current biomass value. The scenario however has not affected the carp biomass. This might have resulted due to the fact that, catfish and carp group are not interrelated in prey-predator relationship. The relationship of catfish and carp group by having similar prey on herbivores zooplankton, are found in excess at the present fish species composition and don't influence one another.

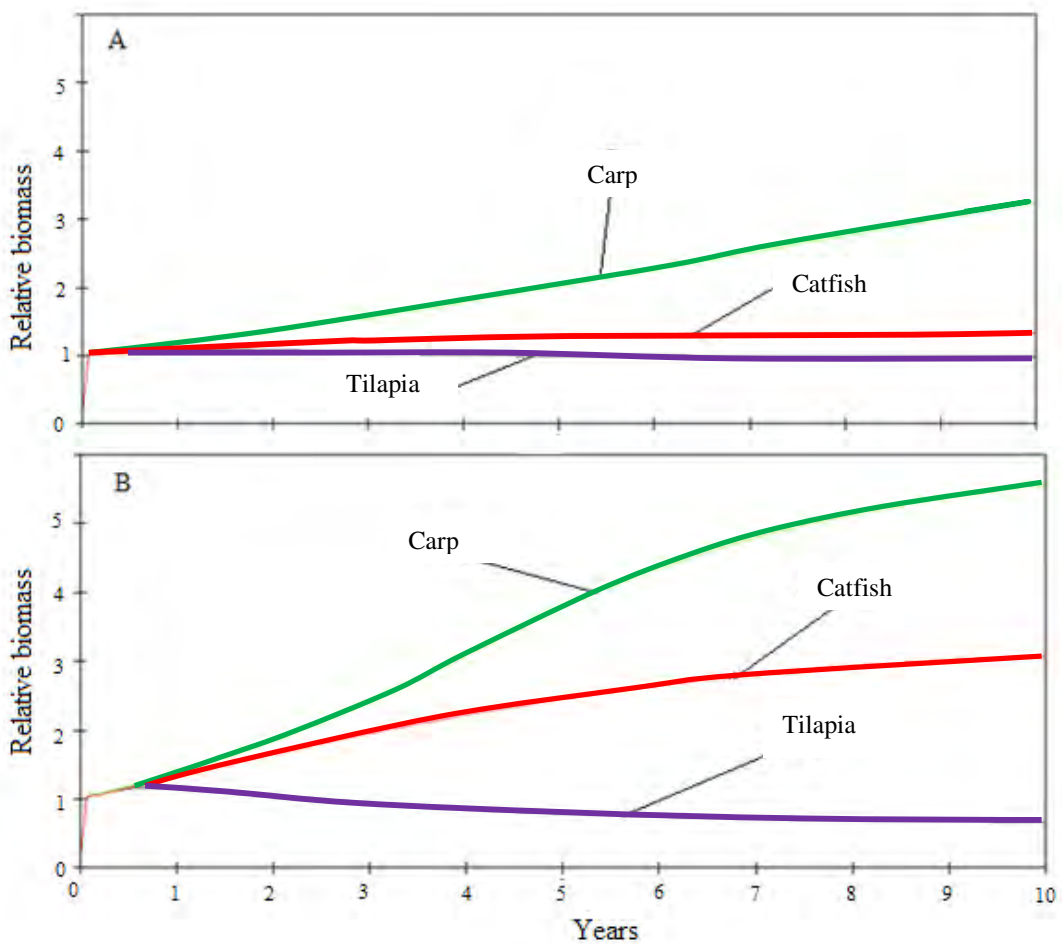

Fig. 11. Relative changes in biomass associated with decreasing the effort of beach seine by 0.25 times (A) and 0.50 times (B) the current effort level.

The second scenarios of decreasing the effort level of beach seine are plotted in Fig 11. The scenarios indicated that at both situations (decreasing the effort of beach seine by 0.25 and 0.50 X) benefited the carp group as their biomass has increased to 3.24 and 5.57 times the current biomass value respectively during ten years period.

However this scenario has not benefited to the tilapia group as their biomass has declined to 0.98 and 0.66 times the current biomass with decreasing in effort of beach seine by 0.25 and 0.50 X respectively. This phenomenon occurred due to the increment in the biomass of catfish by 1.317 and 3.02 at the above scenarios despite the reviving of tilapia from fishing mortality.

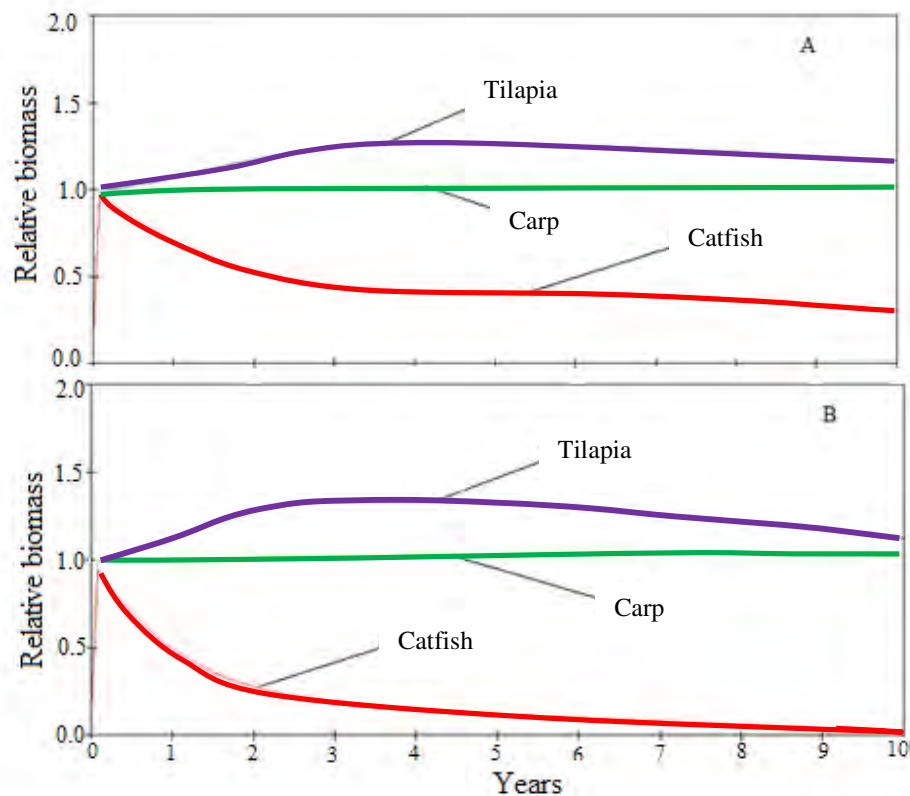

Fig. 12 Relative changes in biomass associated with increasing the effort of Long line to 1.50 times (A) and 2.00 times (B) the current effort level.

The final scenario of increasing the effort long line (Fig 12) has benefited the Tilapia group and significantly decreased the catfish community from the ecosystem. The results of the first and third simulations were similar as both scenarios are targeting the decrement of the Catfish group by setting fishing mortality and effort levels respectively.

From the above scenarios it can be observed that decreasing or increasing both effort of a certain gear should be well planned as it may result in unintended result as the organisms living in the system are inter related through food chain.

The simulation result demonstrated that restricting beach seine fishery by itself may not lead to revival of the tilapia biomass as it has been assumed by some fisheries managers. It was also noted that moderate decrease in the beach seine effort could be helpful for the thriving of carp abundance.

Predictive uses of Ecosim aiming to offer a formal examination of policy-relevant responses of the fish community (i.e., stock dynamics) raises the issue of model credibility, and usually invites a rigorous assessment of the uncertainties associated with the EwE predictions. The current Ecosim simulation is based on setting the vulnerability parameters proportional to their TL which has been applied to various ecosystems (Cheung *et al.*, 2002; Yunkai-Li *et al.*, 2009). However, the predictive ability of this type of simulation is subjected to uncertainty (Christensen *et al.*, 2005). This is due to absence of time series data on fisheries biomass which was valuable in hind casting ability of the model that increases the quality of the forecasted scenario.

## 5. CONCLUSION AND RECOMMENDATION

The Ecopath with Ecosim model constructed to describe the trophic relationships in Lake Ziway helped in understanding the general dynamic of the lake ecosystem. Broad-scale or ecosystem-level approach is recognized as crucial in describing and understanding the trophic structure in Lake Ziway and the importance of the introduced species. It is a requirement to elucidate and, eventually, predict possible impact of exotic species on natural food webs. Fish introductions in Lake Ziway have increased energy flux transfers between TL's.

A low EE value of 0.47 was calculated for the phytoplankton indicating that most of the production remains within the system unutilized. The energy transfer at lower trophic level in Lake Ziway was also much less than other productive African lakes. Therefore, it is necessary to study the microbial loop which might have significant role in lower level trophic efficiency.

As the Carp group (*Carassius carassius* and *Carassius auratus*) and *Clarias gariepinus* are known to be exotic to Lake Ziway but having higher trophic levels in the system indicated that they have contributed to increment in material cycle within the system. Therefore, the possibility of stocking to increase energy transfer should be considered; as introduction can also play a crucial role in enhancing the fishery potential if done properly by studying the available open niche and simulating different scenarios.

Ecosim is considered as the appropriate tool for making long-term predictions as it allows for changes in diet composition with changes in abundance. Present work highlights the possible impact, of change in Catfish fishing mortality and beach seine efforts, on the

lake ecosystem using Ecopath model. Chen *et al.* (2008) substantiated Ecopath modeling as a best tool for ecosystem impact studies and simulating fisheries management options.

Despite the uncertainties associated with model prediction; the biomass/yield of Tilapia in Lake Ziway can be enhanced by increasing the catfish mortality through moderate increment in long line fishery. The simulation result also revealed that restricting beach seine fishery does not help in revival of tilapia population as previously thought by managerial bodies unless it is coupled with increase in long line fishery.

Most uncertainties in the current Ecopath with Ecosim model for Lake Ziway are associated with the lower trophic levels which include (1) the feeding habit of zooplanktons and macro-zoobenthos remain unknown for Lake Ziway or other Lakes of the country. Estimation from models of similar studies could lower the quality and predictive ability of the model. (2) Production estimation for macro-zoobenthos is worth studying as they contribute major share in the food chain of most organisms of Lake Ziway Ecosystem. The use of the existing empirical methods for estimation of macro-zoobenthos production should be taken cautiously as its validity was not tested for tropical lakes with that of cohort based method. (3) The absence of data on bacterial abundance and production and its contribution to microbial loop should be studied as this might explain the inefficiency of lower trophic level energy transfer.

## 6. REFERENCES

- Adamneh Dagne (2010). *Zooplankton community structure, population dynamics and production in relation to abiotic and biotic factors in Lake Ziway, Ethiopia*. Ph.D. Dissertation, Vienna University, Austria.
- Adamneh Dagne, Alois, H., Christian, D.J, and Zenebe Tadesse (2008). Abundance, Species Composition and Spatial Distribution of Planktonic Rotifers and Crustaceans in Lake Ziway (Rift Valley, Ethiopia). *Internat. Rev. Hydrobiol.* **93**: 210-226.
- Alemayehu Negassa and Abebe Getahun (2003). Breeding season, length-weight relationship and condition factor of introduced fish, *Tilapia zillii* Gervais 1948 (Pisces: Cichlidae) in Lake Zwai, Ethiopia. *SINET: Ethiop. J. Sci.* **26**:115-122.
- Alemayehu Negassa and Padanillay, C.P. (2008). Abundance, food habits, and breeding season of exotic *Tilapia zillii* and native *Oreochromis niloticus* L. fish species in Lake Zwai, Ethiopia. *Mj. Int. J. Sci. Tech.* **2**:345-360.
- Alfred, M.B. (2002). Large freshwater lakes: present state, trends, and future prospects. *Environ. Cons.* **29**:21-38.
- Allen, K.R. (1971). Relation between production and biomass. *J. Fish. Res. Board Can.* **28**:1573-1581.
- Arreguin-Sanchez, F., Arcos E., Chavez, E.A. (2002). Flow of biomass and structure in an exploited benthic ecosystem in the Gulf of California, Mexico. *Ecol. Model.* **156**:167-183.
- Bouchard, R.W. (2004). *Guide to aquatic macroinvertebrates of the upper mid west*. Water resources center, University of Minisota, St. paul. M.N 208 pp.
- Brook Lemma (2003). Ecological changes in two Ethiopian lakes caused by contrasting human intervention. *Limnologica* **33**:44-53.

- Bundy, A., Pauly, D. (2001). Selective harvesting by small-scale fisheries: ecosystem analysis of San Miguel Bay, Philippines. *Fish. Res.* **53**:263-281.
- Canonico, G.C., Arthington, A., Mccrary, J.K., and Thiem, M.L. (2005). The effects of introduced tilapias on native biodiversity. *Aquatic Conserv: Mar. Freshw. Ecosyst.* **15**:463–483.
- Chen, Z., Qiu, Y., Jia, X. and Xu, S. (2008). Simulating fisheries management options for the Beibu Gulf by means of an ecological modeling optimization routine. *Fish. Res.* **89**:257-265.
- Cheung, W.L., Watson and Pitcher, T.J. (2002). Policy simulation on the fisheries of HongKong marine ecosystem. **In: Fisheries Centre Research Report No 10**, pp.46-53 (Pitcher, T.J. ed). University of British Columbia, Vancouver, British Columbia, Canada.
- Christensen, V. and Pauly, D. (1993). *Trophic Models of Aquatic Ecosystems*, ICLARM Conference Proceedings, ICLARM. Manila, Philippines, 390 pp.
- Christensen, V. and Walters, C.J. (2004). Ecopath with Ecosim: methods, capabilities and limitations. *Ecol. Model.* **172**:109-139.
- Christensen, V., Walters, C.J. and Pauly, D. (2005). *Ecopath with Ecosim: a User's Guide*. Fisheries Centre Report, Fisheries Center, University of British Columbia, Vancouver, 130 pp.
- Coll, M., Palomera, I., Tudela, S., Sarda, F. (2006). Trophic flows, ecosystem structure and fishing impacts in the South Catalan Sea, Northwestern Mediterranean. *J. Mar. Syst.* **59**:63-96.
- Covich, A.P., Ewel, K.C., Hall, R.O., Giller, P.E., Goedkoop, W. and Merritt, D.M. (2004). Ecosystem services provided by freshwater benthos. pp.45–72. **In: Sustaining Biodiversity and Ecosystem Services in Soil and Sediments** (Wall, D.H. ed.), Island Press, Washington.

- Daba Tugie and Mesert Taye (2004). Reproductive biology and feeding habit of African catfish (*Clarias gariepinus*, Burchell, 1982) in Lake Ziway, Ethiopia. **In: Conference proceeding of Ethiopian Society of Animal Production.** pp.199-208 Addis Ababa.
- Defaye, D. (1988). Contribution a la connaissance des Crustaces Copepods d’Ethiopie. *Hydrobiologia* **164**:103-147.
- Demeke Admassu and Ahlgren, I. (2000). Growth of juvenile tilapia, *Oreochromis niloticus* L. from Lakes Zwai, Langenoo and Chamo (Ethiopian rift valley) based on otolith microincrement analysis. *Ecol. Fresh. Fish.* **9**:127-137.
- Dengbol, L. (1993). The pelagic zone of central Lake Malawi-A tropic box model. **In: Trophic models of aquatic ecosystems**, pp. 110-115, (Christensen, V. and Pauly, D., eds). ICLARM Conference Proceedings No. 26, Manila.
- Dumont, H.J., Van de Velde, I. and Dumont, S. (1975). The dry weight estimate of biomass in a selection of Cladocera, Copepoda and Rotifera from the plankton, periphyton and benthos of continental waters. *Oecologia* **19**: 75–97.
- Durand, J.R. and Leveque, C. (1981). Flore et Faune aquatique Sahelo-Soudanienne. Paris, pp 873.
- Dussart, B.H. and Fernando, C.H. (1988). Sur quelques *Mesocyclops* (Crustacea, Copepoda). *Hydrobiologia* **157**:241-264.
- Edmondson and Winberg, G.C (1971). *A manual on methods for the assessment of secondary productivity in fresh waters*. Oxford black well Sci. Publ. IBP hand book 17, 358 pp.
- Elizabeth Kebede and Willen, E. (1998). Phytoplankton in a salinity series of lakes in the Ethiopian Rift Valley. *Algol. Studi.* **89**:63-96.

- Eshete Dejen, Vijverberg, J. and Abebe Getahun (2010). The biodiversities of nine Ethiopian lakes along a north south gradient: threats and possible solutions. **In: Management of shallow water bodies for improved productivity and peoples livelihoods in Ethiopia**, pp.155-160 (Seyoum Mengistou and Brook Lemma eds), EFASA, Addis Ababa.
- Eyualem Abebe and Getachew Tefera (1992). Seasonal changes in nutritional status of *Oreochromis niloticus* L. (Pisces: Cichilidae) in Lake Ziway, Ethiopia. *Arch. Hydrobiol.* **124**:109-122.
- Felegeselam Yohanes (2003). *Management of Lake Ziway fisheries in Ethiopia*. M.Sc Thesis, University of Toromso, 60 pp.
- Fernando, C.H. (2002). *A guide to tropical freshwater zooplankton: Identification, ecology and impact on fisheries*. Backhuys Publishers, Leiden, 291 pp.
- Fernando, C.H., Seyoum Mengistou and Semeneh Belay (1990). The chydorid crustacean, *Alona diaphana* (King), limnetics in Lakes Awassa and Ziway, Ethiopia, with a discussion of littoral and limnetic zooplankton. *Intern. Rev. ges. Hydrobiol.* **75**:15-25.
- Gashaw Tesfaye (2006). *Population dynamics and stock assessment of Nile tilapia (Oreochromis niloticus L.) in three rift valley lakes (Koka, Ziway and Langano), Ethiopia*. M.Sc. Thesis. Bremen University, Bremen, 80 pp.
- Gayanilo, F.C., Sparre, P. and Pauly, D. (2005). *The FAO-ICLARM Stock Assessment Tools II (FiSAT II Ver. 2.0)*, FAO.
- Getachew Beneberu (2005). *Study on littoral dynamics in Lake Ziway*. M.Sc. Thesis. Addis Ababa University, Addis Ababa, 65 pp.
- Girma Tilahun (1988). *A seasonal study on primary production in relation to light and nutrients in Lake Zwai, Ethiopia*. M.Sc. Thesis, Addis Ababa University, Addis Ababa pp. 62.

- Girma Tilahun (2006). *Temporal dynamics of the species composition, abundance and size-fractionated biomass and primary production of phytoplankton in Lakes Ziway, Awassa and Chamo (Ethiopia)*. Ph.D. Thesis, Addis Ababa University, Addis Ababa, 201pp.
- Girma Tilahun and Ahlgren, G. (2009). Seasonal variations in phytoplankton biomass & primary production in the Ethiopian Rift Valley lakes Ziway, Awassa and Chamo-The basis of fish production. *Limnologica*. doi:10.1016/j.limno.2009.10.005.
- Globstov, A.S., Dgebuadze, Yu, Yu, and Mina, M.V. (2002). Fishes of the Ethiopian rift valley. **In:** *Ethiopian rift valley Lakes*. pp. 167-256 (Tudorance, C. and Taylor, W.D. eds). Backhuys publishers, Leiden.
- Green, J. and Seyoum Mengistou (1991). Specific diversity and community structure of Rotifera in a salinity series of Ethiopian inland waters. *Hydrobiologia* **209**:95-106.
- Harte, J. (2007). Human population as a dynamic factor in environmental degradation. *Population and Environ.* **28**:223-236.
- Hossain, M.M., Matsuishi, T. and Arhonditsis, G. (2010). Elucidation of ecosystem attributes of an oligotrophic lake in Hokkaido, Japan, using Ecopath with Ecosim (EwE). *Ecol. Model.* **221**:1717-1730.
- Jones, J.G. (1979). *A Guide to Methods for Estimating Microbial Numbers and Biomass in Fresh Water*. Freshwater Biological Association, Scientific Publication No. 39.
- Kipkemboi, J. (2006). *Fingerponds: seasonal integrated aquaculture in East African freshwater wetlands*. Ph.D. Dissertation, UNESCO-IHE, Netherland, 168pp.
- Levine, J.M., Vila, M., D'Antonio, C.M., Dukes, J.S., Grigulis, K. and Lavorel, S. (2003). Mechanisms underlying the impact of exotic plant invasions. *Phil. Trans. R. Soc. Lond.* **270**:775-781.

- LFDP (1996). *Proceedings of the National Fisheries Seminar, Ziway. Lake Fisheries Development Project Working Paper no. 21*. Ministry of Agriculture. Addis Ababa.
- LFDP (1997). *Lake management plans. Lake fisheries development project, phase II: working paper 23*. Ministry of Agriculture. Addis Ababa.
- LFDP (1998). *Fisheries Report, Phase II*. Animal and Fisheries Resources Development Department (MOA). Addis Ababa, Ethiopia, 61 pp.
- Loreau, M., Naeem, S., Inchausti, P., Bengtsson, J., Grime, J.P., Hector, A., Hooper, D.U., Huston, M.A., Raffaelli, D., Schmidt, B., Tilman, D. and Wardle, D.A. (2001). Biodiversity and ecosystem functioning: current knowledge and future challenges. *Science* **294**:804-808.
- Machena, C., Kolding, J. and Sanyanga, R.A. (1993). A preliminary assessment of the trophic structure of Lake Kariba: a man-made lake, Africa. **In:** *Trophic models of aquatic ecosystems*, pp. 130-137, (Christensen, V. and Pauly, D., eds). ICLARM Conference Proceedings No. 26, Manila.
- Magadza, C.H.D. (2010). Environmental state of Lake Kariba and Zambezi River Valley: Lessons learned and not learned. *Lakes and Reservoirs: Res. Manag.* **15**:167-192.
- Majkowski, J. (1982). Usefulness and applicability of sensitivity analysis in a multispecies approach to fisheries management. **In:** *Theory and Management of Tropical Fisheries*. pp. 149–165, (Pauly, D. and Murphy, G.I. eds). ICLARM Conference Proceeding. Manila.
- Makin, M., Kingham, J.J., Waddam, A.E., Birchall, C.J. and Tamene Tefera (1975). *Development projects in the Southern Rift Valley of Ethiopia. Land Resources Study 21*. Land Resources Division. Ministry of Overseas Development, England.

- Matsuishi, T., Muhoozi, L., Mkumbo, O., Budeba, Y., Njiru, M., Asila, A., Othina, A., and Cowx, I.G. (2006). Are the exploitation pressures on the Nile perch fisheries resources of Lake Victoria a cause for concern? *Fish. Manag. Ecol.* **13**:53-71.
- Mavuti, K., Moreau, J., Munyadorero, J. and Plisnier, P.D. (1996). Analysis of trophic relationships in two shallow equatorial lakes Lake Naivasha (Kenya) and Lake Ihema (Rwanda) using a multispecies trophic model. *Hydrobiologia* **321**:89-100.
- Moreau, J., Ligtoet, W., and Palomares, M.L.D. (1993). Trophic relationship in the fish community of Lake Victoria, Kenya, with emphasis on the impact of Nile perch (*Lates niloticus*). **In:** *Trophic models of aquatic ecosystems*, pp. 144–152, (Christensen, V. and Pauly, D., eds). ICLARM Conference Proceedings No. 26, Manila.
- Moreau, J., Mavuti, K. and Daufresne, T. (2001). A synoptic Ecopath model of biomass flows during two different static ecological situations in Lake Nakuru (Kenya). *Hydrobiologia* **458**:63-74.
- Nielsen, S.N. and Muller, F. (2009). Understanding the functional principles of nature: Proposing another type of ecosystem services. *Ecol. Model.* **220**:1913–1925.
- Odum, E.P. (1969). The strategy of ecosystem development. *Science* **104**:262–270.
- Palomares, M.L.D. and Pauly, D. (1998). Predicting food consumption of fish populations as functions of mortality, food type, morphometrics, temperature and salinity. *Mar. Freshw. Res.* **49**:447–453.
- Pascual, M. and Dunne, J.A. (2006). *Ecological Networks: Linking Structure to Dynamics in Food Webs*. Oxford University Press, New York, 386 pp.
- Pauly, D. (1983). Some simple methods for the assessment of tropical fish stocks. *FAO Fisheries Technical Paper Rome*, 234 pp.

- Pauly, D., Christensen, V. and Walters, C. (2000). Ecopath, Ecosim and Ecospace as tool for evaluating ecosystem impact of fisheries. *ICES J. Mar. Sci.* **57**:1-10.
- Pauly, D., Christensen, V., Dalsgaard, J., Froese, R. and Torres Jr., F. (1998). Fishing down marine food webs. *Science* **279**:860-863.
- Pearce, D. (1998). Auditing the Earth: the value of the world's ecosystem services and natural capital. *Environment* **40**:23-27.
- Piedade, M.T.F., Junk, W.J. and Long, S.P. (1991). The productivity of the C4 grass *Echinochloa polystachya* on the Amazon floodplain. *Ecology* **72**:1456-1463.
- Plante, C. and Downing, J.A. (1989). Production of freshwater invertebrate populations in lakes. *Can. J. Fish. Aquat. Sci.* **46**:1489-1498.
- Polovina, J.J. (1984). Model of a coral reef ecosystem. Part I. Ecopath and its application to French Frigate Shoals. *Coral Reefs* **3**:1-11.
- Reyes-Merchant, P., Jamet J.L., Nair, N., Taleb, H., and Palomares, M.L.D. (1993). A preliminary ecosystem model of a eutrophic lake (Lake Aydat, France). **In:** *Trophic models of aquatic ecosystems*, pp. 90-94, (Christensen, V. and Pauly, D., eds). ICLARM Conference Proceedings No. 26, Manila.
- Ruttner-Kolisko, A. (1977). Suggestions for biomass calculation of plankton rotifers. *Hydrobiol. Beih. Ergebn. Limnol.* **8**:71-76.
- Schroder, R. (1984). An attempt to estimate the fish stock and the sustainable yield of Lake Ziway and Lake Abaya, Ethiopian Rift Valley. *Arch. Hydrobiol.* **3**:411-441.
- Semeneh Belay (1988). *Zooplankton composition and seasonal dynamics in Lake Ziway, Ethiopia*. M.Sc. Thesis. Addis Ababa University, Addis Ababa, 121 pp.

- Seyoum Mengistou and Fernando, C.H. (1991). Seasonality and abundance of some dominant crustacean zooplankton in Lake Awasa, a tropical rift valley lake in Ethiopia. *Hydrobiologia* **226**:137-152.
- Stiassny, M. J. and Abebe Getahun (2007). An overview of labeonin relationships and the phylogenetic placement of the Afro-Asian genus *Garra* Hamilton, 1922 (Teleostei: Cyprinidae), with the description of five new species of *Garra* from Ethiopia, and a key to all African species. *Zool. J. Linn. Soci.* **150**:41-83.
- Tadesse Fetahi and Seyoum Mengistou (2007). Trophic analysis of Lake Awassa (Ethiopia) using mass-balance Ecopath model. *Ecol. Model.* **201**:398-408.
- Tadesse Fetahi, Schagerl, M., Seyoum Mengistou and Libralato, S. (2011). Food web structure and trophic interactions of the tropical highland lake Hayq, Ethiopia. *Ecol. Model.* **222**:804-813.
- Talling, J.F. and Driver, D. (1963). Some problems in the estimation of chlorophyll a in phytoplankton. **In: *Proceeding Conference on primary productivity measurement, marine and freshwater***, pp. 142-146, U.S Atomic energy comm. TID 7633.
- Talling, J.F. and Lemoalle, J. (1998). Ecological dynamics of tropical inland waters. Cambridge University Press, UK, 441 pp.
- Tenalem Ayenew and Dagnachew Legesse (2007). The changing face of the Ethiopian rift lakes and their environs: call of the time. *Lakes and Reservoirs: Res. Manag.* **12**:149-165.
- Tsegaye Miheretab (1988). *A seasonal study on the species composition and phytoplankton biomass in Lake Ziway, Ethiopia*. M.Sc. Thesis, Addis Ababa University, 72 pp.
- Ulanowicz, R.E. (1986). Growth and Development: Ecosystem Phenomenology. Springer-Verlag, New York, 203 pp.

- Ulanowicz, R.E. (1995). The part-whole relation in ecosystems. **In:** *Complex Ecology*, pp. 549-560 (Patten, B.C., Jorgensen, S.E. eds). Prentice-Hall, Englewood Cliffs, New Jersey.
- Van de Velde, I. (1984). Revision of the African species of the genus *Mesocyclops* Sars, 1914 (Copepoda: Cyclopoida). *Hydrobiologia* **109**:3-66.
- Villanueva, M.C.S., Isumbisho, M., Kaningini, B., Moreau, J. and Micha, J. (2008). Modeling trophic interactions in Lake Kivu: What roles do exotics play? *Ecol. Model.* **212**:422-438.
- Vitule, J.R.S., Freire, C.A. and Simberloff, D. (2009). Introduction of non-native freshwater fish can certainly be bad. *Fish and Fish.* **10**:98-108
- Voigt, M. and Koste, W. (1978). *Rotatoria*. Gebruder Borntraeger, Berlin, Stuttgart, 468 pp.
- Walters, C., Pauly, D. and Christensen, V. (1999). Ecospace, prediction of meso-scale spatial patterns in trophic relationships of exploited ecosystems, with emphasis on the impacts of marine protected areas. *Ecosystems* **2**:539-554.
- Walters, C.J., Christensen, V. and Pauly, D. (1997). Structuring dynamic models of exploited ecosystems from trophic mass-balance assessments. *Rev. Fish. Biol.* **7**:139-172.
- Welcomme, R.L. (1988). *International Transfers of Inland Fish Species*. FAO Fisheries Technical Papers 294, Rome, 318 pp.
- Witte, F., Goldschmidt, T., Goudswaard, P., Ligtoet, W., van Oijen, M. and Wanink J.H. (1992). Species extinction and concomitant ecological changes in Lake Victoria. *Nether. J. Zool.* **42**:214-232.
- Wood, R.B. and Tailing, J.F. (1988). Chemical and algal relationships in a salinity series of Ethiopian inland waters. *Hydrobiologia* **158**:29-67.

- Woodward, G. (2009). Biodiversity, ecosystem functioning and food webs in fresh waters: assembling the jigsaw puzzle. *Freshw. Biol.* **54**:2171-2187.
- Yunkai-Li, Chen, Y., Song, B., Olson, D., Yu, N. and Liqiao-Chen (2009). Ecosystem structure and functioning of Lake Taihu (China) and the impacts of fishing. *Fish. Res.* **95**:309-324
- Zenebe Tadesse (1988). *Studies on some aspects of the biology of Oreochromis niloticus in Lake Ziway, Ethiopia*. M.Sc. Thesis. Addis Ababa University, Addis Ababa, 78 pp.
- Zinabu Gebremariam, Elizabeth Kebede and Zerihun Desta (2002). Long-term changes in chemical features of waters of seven Ethiopian rift-valley lakes. *Hydrobiologia* **477**:81-91.

## 7. APPENDICES

### Appendices 1 Phytoplankton identified from Lake Ziway during the study period

Cyanobacteria	Chlorophyta	Bacilariophyta	Euglenophyta
<i>Anabena Spp.</i>	<i>Closterium spp.</i>	<i>Cyclotella sp.</i>	<i>Phacus sp</i>
<i>Cylindrospermopsis Spp.</i>	<i>Cosmarium sp.</i>	<i>Navicula sp.</i>	
<i>Microcystis Spp.</i>	<i>Pediastrum boryanum</i>	<i>Nitzschia sp.</i>	
	<i>Pediastrum duplex</i>	<i>Gyrosigma sp.</i>	
	<i>Pediastrum simplex</i>	<i>Meliosera sp.</i>	
	<i>Senedesmus spp.</i>	<i>Surirella sp.</i>	
	<i>Staurastrum spp.</i>		

### Appendices 2 Macro-zoobenthos communities of Lake Ziway

Taxa	Order	Family
Hiridinae		
Oligochaeta		Tubificidae
Nematoda		
Insecta	Hemiptera	Corixidae Pentatomidae
	Ephemeroptera	Potamanthidae Baetidae Caenidae
	Odonata	Coenogriidae
	Lepidoptera	Psychodidae
	Plecoptera	
	Coleoptera	Elmidae
	Diptera	Chironomidae Ceratopogonidae
Molluskca	Gastropoda	Planorbidae Melonidae
	Bivalvia	Corbiculidae

Appendices 3 Absolute flow at each aggregated trophic level in Lake Ziway ecosystem

<b>Group name / Trophic level</b>	<b>I</b>	<b>II</b>	<b>III</b>	<b>IV</b>	<b>V</b>
<b>1</b> Waterfowls	0.000	0.000	0.104	0.0355	0.000086
<b>2</b> Cat fish	0.000	0.521	4.232	0.451	0.00199
<b>3</b> Carp	0.000	4.284	2.904	0.0731	0.000382
<b>4</b> Tilapia	0.000	35.62	0.721	0.00562	0.000
<b>5</b> Barbus	0.000	0.498	2.426	0.00566	0.000
<b>6</b> Garra	0.000	0.176	1.583	0.000680	0.000
<b>7</b> Macro-zoobenthos	0.000	1767	0.000	0.000	0.000
<b>8</b> Carnivores zooplankton	0.000	0.717	2.525	0.0171	0.000
<b>9</b> Herbivores zooplankton	0.000	1444	11.26	0.000	0.000
<b>10</b> Phytoplankton	3869	0.000	0.000	0.000	0.000
<b>11</b> Macrophyte	433.7	0.000	0.000	0.000	0.000
<b>12</b> Detritus	3403	0.000	0.000	0.000	0.000
Total	7706	3252	25.75	0.588	0.00246

Appendices 4 Cycles and pathways in Lake Ziway Ecosystem

<b>Parameter</b>	<b>Value</b>	<b>Unit</b>
Throughput cycled (excluding detritus)	164.26	t/km <sup>2</sup> /year
Predatory cycling index	3.93	% of throughput without detritus
Throughput cycled (including detritus)	650.63	t/km <sup>2</sup> /year
Finn's cycling index	5.92	% of total throughput
Finn's mean path length	2.553	

## DECLARATION

I, the undersigned, hereby declare that this thesis is my original work, has not been presented for a degree in any other University and all source of materials used for the study have been duly acknowledged.

Name: Mathewos Hailu

Signature: \_\_\_\_\_

Place: Addis Ababa University

Date: \_\_\_\_\_

This work has been presented with our approval as supervisor.

Name: Tadesse Fetahi (PhD)

Name: Seyoum Mengistou (PhD)

Signature: \_\_\_\_\_

Signature: \_\_\_\_\_

Date: \_\_\_\_\_

Date: \_\_\_\_\_