

# **ADDIS ABABA UNIVERSITY**

## **ADDIS ABABA INSTITUTE OF TECHNOLOGY**



### **Design and Optimization of Electric Motor Driven Mechanical Oil Press**

by

**Addisalem Mekonnen**

A thesis submitted to the School of Graduate Studies of Addis Ababa  
University in partial fulfillment of the requirement of the Degree of  
Masters of Science in Mechanical Engineering  
(Mechanical Design Stream)

Advisor

**Dr.-Ing. Zewdu Abdi**

**November, 2013**

## **Acknowledgment**

First of all and fore- most I would like to give my sincere gratitude to my project advisor Dr.-Ing. Zewdu Abdi for giving me comments, ideas and some material related with my title on different parts of the project. I have also a great pleasure in expressing my special thanks to my friends who helped me by shearing their knowledge on some parts of the project. I am also deeply indebted to my parents for their inspiration and ever encouraging moral support, which enabled me to complete my studies.

Lastly I would like to express gratitude to anyone who has contribution in many ways for successful completion of this project.

### **Abstract**

There are different types of oil press machine developed previously which are used to squeeze oil from different types of an oil seed. In this Research work one type of oil press, manually operated oil press, is improved into electric motor driven mechanical oil press with rack and pinion gear system as a main mechanical part of the machine. This improvement is used to solve the cost problem, reduce work time, and streamline the existing machine to be more efficient and productive.

The main procedures to comply this improvement are design of parts of the machine to get optimized dimensions of the parts and setting the controlling mechanism. In this procedure main parts of the machine are designed to find their dimensions and to select appropriate material and also its stress analysis is performed using finite element analysis software to find stress concentration area and its maximum stress value and then to compare with values obtained in the design analysis. The other part and power source of the machine is an electric motor, in this thesis it is also dealt with selection of motor type including its specification for safe and appropriate operation. The controlling mechanism of the motor using microcontroller for automatic operation of the motor is selected and assembly language has been written since the motor is bi-directional or it rotates clockwise and anti-clockwise, which is used to move the ram up and down. After completing the design obtained results and selected materials are safe to squeeze edible oil.

## Table of Contents

Acknowledgment .....	ii
Abstract .....	iii
List of Figures .....	iv
List of tables .....	v
Acronym.....	viii
1. Introduction.....	1
1.1 Background .....	1
1.2 Statement of the problem .....	3
1.3 Objective .....	3
2. Literature review .....	4
3. Method, Material and Procedure.....	14
3.1 Methods.....	14
3.2 Materials.....	14
4. Design of mechanical parts of oil press.....	16
4.1 Design features .....	16
4.2 Design analyses .....	16
4.3 Design of Gear system.....	17
4.3.1 Design of pinion .....	17
4.3.2 Rack .....	30
4.4 Shaft design .....	31
4.5 Bearing Selection.....	36
4.6 Design of power press/ Ram .....	38
4.7 Oil filter sheets .....	39
5. Control unit .....	41
5.1 Motor type .....	41
5.2 System operation .....	42
5.3 Controlling mechanism.....	42
5.3.1 Microcontroller and motor driver .....	43
5.3.2 L293 motor driver.....	45

5.4 Programming for controlling DC motor .....	46
5.4.1 Assembly language .....	47
5.4.2 Assembly language written for 8051 microcontroller .....	47
6. Stress analysis .....	49
6.1 Concept of stress analysis .....	49
6.2 Why stress analysis .....	49
6.3 Steps of conducting stress analysis .....	51
6.4 Finite Element Analysis .....	52
6.5 Modeling .....	53
6.6 Contour plot of stress analysis.....	62
7. Conclusion and Recommendation .....	65
8. Reference .....	68

## List of Figures

Fig. 1 Ram press .....	8
Fig. 2 Screw press .....	9
Fig. 3 Coconut oil pressing machine .....	11
Fig.4 Solar powered screw oil press .....	12
Fig.5 Oil press using human powered flywheel motor .....	13
Fig.6 Rack and pinion gear .....	17
Fig.7 Nomenclature of rack and pinion .....	18
Fig.8 Rack teeth geometry .....	31
Fig.9 Components on shaft .....	32
Fig.10 Shear force and bending moment diagram .....	34
Fig.11 bearing nomenclature .....	37
Fig.12 Oil filter sheet .....	40
Fig.13 Components of microcontroller .....	44
Fig.14 Pin Diagram of 8051.....	45
Fig.15 Interfacing of L293, motor and microcontroller .....	46
Fig.16 Steps of conducting stress analysis .....	51
Fig.17 Parameters for pinion modeling .....	55
Fig.18 Nomenclature to describe the four circles .....	56
Fig.19 3D model of pinion using Catia .....	59
Fig.20 Two dimensional view of gear .....	60
Fig.21 Steps in performing stress analysis using Catia .....	60
Fig.22 Inputs for the analysis of stress .....	61
Fig.23 Catia result of Deformation .....	62
Fig.24 Contour plot of Von misses stress .....	62
Fig.25 Contour plot of Displacement .....	63
Fig.26 Principal Stress .....	64
Fig.27 Electrical motor driven Mechanical oil press.....	67

## List of Tables

Table 1 Values of the Lewis Form Factor Y .....	20
Table 2 AGMA reliability factor .....	25
Table 3 Elastic coefficient .....	27
Table 4 Summarized result of design of gear .....	30
Table 5 Dimensions and Load Ratings for Single-Row 02-Series Deep-Groove and Angular Contact Ball Bearings.....	36
Table 6 Parameters for gear modeling .....	57

## **Acronym**

CAA- Component Application Architecture

CAD - Computer aided design

CAE - Computer aided engineering

CAM - Computer aided manufacturing

CATIA- Computer Aided Three-Dimensional Interactive Application

CMOS- Complementary metal oxide semiconductor

DOF- Degree of freedom

HLL- High level language

I/O- Input Output

RAM- Random access memory

ROM- Read only memory

## **1. Introduction**

### **1.1 Background**

Oil can be extracted manually or using power source by pressing softer oilseeds, such as round nuts and shea nuts, whereas harder, more fibrous materials such as copra and sunflower seed can be processed. Pulped or ground material is loaded into a manual or hydraulic press to squeeze out the oil-water emulsion. This is more efficient at removing oil than traditional hand squeezing, allowing higher production rates [1].

In Germany, at the institute of Agricultural Engineering in freising Weihenstephan, small scale extraction of rape seed oil has been studied in laboratory [2]. Capacity, oil extraction efficiency, requirements for power and energy, optimal adjustment, cleaning of the oil, and settling has been studied. Similar investigations have been made in USA [3].

An oil press machine system comprised of three subsystems; energy unit, mechanical power transmission system and processing unit. Energy unit comprised of a motor with programmed microcontroller to control directional motion of the machine through shaft connected to it. The mechanical power transmission unit is composed mainly of the gear system, rack and pinion gear type which is used to allow up and down movement of the press. The processing unit mainly consists of oil tank, cylinder used to store the oil seed, oil filter sheet which is used to differentiate the oil with husks or seed coats during oil extraction process.

The full automatic oil pressing complete set of equipment is suitable for extracting different kinds of oil seeds continuously. Seed oil press machine, as the word tells, is widely used in squeezing oil from oil seed such as soybeans, peanut, sunflower seed, cotton etc. All seed oil press machine characterized by their simple design, easy to use, wide suitability and continuous operation, and high productivity and high oil output rate.

### **Press**

A press is a sheet metal working tool with a stationary bed and a powered ram which can be driven towards the bed or away from the bed to apply force or required pressure for various metal forming operations. The relative positions of bed and ram in the press are decided by the structure of its frame. The punch is generally gripped into the punch holder and punch holder is attached to ram. A blaster steel plate is attached to the bed of the press and a die is mounted on the blaster steel plate.

Power systems on presses are either hydraulic presses using a large piston or cylinder to drive the ram. This system is capable to provide longer ram strokes than mechanical dies. It gives a consistent applied load. Its working speed is comparatively slower. These presses can be single action or double action or more. Number of actions depends on the number of slides operating independently.

Mechanical presses utilize several types of drive mechanisms. These drives include eccentric, crankshaft, knuckle joint, etc. These drives are used to convert rotational motion given by a motor into linear motion of the ram. A fly- wheel is generally used as reservoir of energy for forging operations. These presses are recommended for blanking and punching operations as the involved drives are capable to achieve very high forces at the end of their strokes.

### **Rack and Pinion Press**

Rack and pinion driven presses are called rack and pinion presses meant for long strokes. Major advantage is faster operation of this press due to involvement of quick return motion.

Gearing is one of the most effective methods transmitting power and rotary motion from the source to its application with or without change of speed or direction. Gears will prevail as a critical machine element for transmitting power in future machines due to their high degree of reliability and compactness.

## 1.2 Statement of the problem

During searching of an idea for a problem for the thesis I visited a place called Selam children's village which is technical school and a place where income generating activities are performed. In this company I saw oil press machine which operated manually. This machine needs continuous involvement of man power. There are many factors affecting the performance of manually operated oil press. In this thesis work I want to improve this machine by adding some Mechatronics concept and make it motor driven oil press machine. In addition to this since the main part of this machine is gear system, this thesis also focuses on design of the gear system for an optimum size and dimension as well as stress analysis on the system was performed using finite element analysis software, Catia.

## 1.3 Objective

General objective

- The main objective of this thesis is to improve manually operated mechanical oil press machine in to motor driven oil press and perform the design aspect of the major parts of the machine.

Specific objective

- To improve the operating mechanism of the machine and to perform the design of different parts of the machine.
- To find the required power and power source for the machine and match accordingly.
- To perform stress analysis of the rack and pinion gear as well as the shaft.
- To add Mechatronics control using microcontroller on the machine to replace manual operation.
- To optimize the parameters of parts of oil press machine.
- To model parts as well as assembly of the machine.

## 2. Literature review

There are great deal of researchers and number of literatures on oil extraction process and oil press has been done and published. Generally their main concerns were on the physical and chemical properties of oil seed, oil extraction process from these seeds and about different oil press machines with various approaches and means.

This chapter attempts to review literatures, which are relevance to oil extraction process and different oil presses.

### Oil seed

Many seeds, nuts, and kernels contain oil that can be extracted and used in cooking, as an ingredient in other foods, as a nutritional supplement, and as a raw material for the manufacture of soap, body and hair oils, detergents, and paints. Some of these oils may also be used to replace certain petroleum based lubricants and fuels. For this thesis Niger seed which is used for edible oil is used and some literatures which are relevant with it will be discussed.

### Niger seed

Niger seed (*Guizotia abyssinica*) is an erect, stout, branched annual herb, grown for its edible oil and seed. Its cultivation originated in the Ethiopian highlands, and has spread to other parts of Ethiopia. Common names include: Niger, nyger, nyjer, or Niger seed; ramtil or ramtilla; Inga seed; and black seed. In Ethiopia 50-60% of the edible oil requirement for domestic consumption is obtained from Niger seed [4].

Niger is a seed from *Guizotia abyssinica* plant, which is a kind of an herb and widely grown in Africa and India. This herb is grown especially for its seeds. Niger seeds in India and other countries are not only grown for attracting birds through its seedlings, but also they are used for extracting edible oil. These seeds are rich in protein and other nutritional values; hence they supply lots of energy to the birds.

### Features:

- Used for medicated shampoo, medicine, anti aging treatments, anti aging skin care
- Utilized for varied industrial applications such as paints preparations, soap making
- Known for their high oil as well as protein contents

The basic nutritional components of Niger seed are: [31]

- 35 percent fat
- 18 percent protein
- 18 percent fiber
- 12 percent moisture

Because of this composition, Niger seed is especially popular for edible oil.

### **Oil extraction**

The major operations involved in the production of oil are cleaning of the raw material, conditioning, pressing, filtering and storage.

At the first step oil seeds are properly cleaned by dehulling. After cleaning operation the seeds are taken to the expeller (or Press) as needed. The expeller breaks up to seed and subject it to pressure, thereby removing oil which is expelled from the machine and can be stored in drums.

Oil extraction can be done mechanically with an oil press, expeller, or even with a wooden mortar and pestle-a traditional method that originated in India [32].

Presses have a number of different designs, commonly based on a bridge press. In all types, a batch of raw material is placed in a heavy-duty perforated metal cage and pressed by the movement of a plunger. The amount of material in the cage varies from 5-30 kg with an average of 20 kg. Layer plates can be used in larger cages to provide a constant pressure through the bulk of material and speed up removal of oil.

Historically, such oils have been extracted by wrapping seeds in cloth, and then using devices operated by stones and levers to exert pressure on them. [32] An improved form of mechanical device, which allowed considerably more pressure to be exerted, involves the use of hydraulically operated rams: a simple, hand-operated cylinder pumps are used to press flat plates or hollow cages attached to the hydraulic ram against a fixed-position ram.

This type of press developed into a motorized hydraulic pump system that pressed the seed bag and then released a press cake.

The next improvement in extracting oil was the screw press or expeller. Screw presses use an electric motor to rotate a heavy iron shaft, which has flights, or worms built into it to push the seeds through a narrow opening. The pressure of forcing the seed mass through this slot releases part of the oil, which comes out through tiny slits in a metal barrel fitted around the rotating shaft. Expellers have a continuous flow of seed through the machine in contrast to the hydraulic system described above, which uses small, individual packages or batches of seed. To release as much oil as possible, the seeds must be dried to rather low moisture content and espousing to high temperature causes darkening of the oil [33]. It also causes some scorching or overheating of the meal. The meal contains protein which, if undamaged, may be used for either human food, soy flour for example, or animal feed such as soybean meal. Because most press or expeller processes overheat the meal and leave too much of the high value oil in the seedcakes, methods of extracting the oil with solvents were developed. Seeds (like soybeans) with low oil content are processed by solvent methods alone. In other cases, presses are used first to extract part of the oil; then solvents extract the oil that remains in the seeds [5, 6, and 7].

### **Oil press**

Oil Press Machine is used in the oil mills. The machine is most appropriate for cleaning oil drawn from different explorer machines. This machine can be used to extract oil from oil seeds like ground nut, soya bean, sesame seed, rep seed, palm kernels, mustard seeds, castor seeds, cotton seeds, sun flower and copra. During pressing, the press can filter the oil in due time. After pressing and filtering, we can get pure oil from materials. It can save labor and save cost: only 1 or 2 individuals can finish the production. It requires low investment and generates high profit, machine covers small space, performing perfectly, and it is easy-to-operate. The automatic oil pressing complete set of equipment is suitable for extracting kinds of oil-materials by continuous power supply. The technology development has been continuing to solve the cost problem, aiming to reduce work time, to simplify the existing machine to be more efficient and productive, including designing the device to replace human labor.

Advantage of electric motor driven oil press over manually operated one

- High efficiency
- High processing capability
- High oil press rate
- Easy to operate
- Save time

The **ram press** is a low-cost, manual technology for extracting edible oil and byproduct animal feed from oilseeds. This durable press can be made in informal sector rural workshops and does not require additional pre-pressing equipment. About 800 of these presses have been produced in Tanzania on a commercial basis. Press owners report sizable income gains and rural consumers benefit from increased availability of cooking oil. The ram press had not been invented when the Arusha project began. At first, the project was going to promote a different technology developed at the University of Tanzania's Institute for Production Innovation (IPI). The IPI technology consists of a medium-scale scissors-jack press and a decorticator, scorcher, and roller for preprocessing. The original goal of this project was the establishment of 10 medium-scale sunflower seed oil extraction enterprises in the region over a four-year period [8].



Fig. 1 Ram press

The design of the ram press has evolved over time. The original Bielenberg model was produced commercially for over a year and sold for about \$450 in Tanzania. It had a relatively large piston to take in a sizable amount of seed, but required a considerable amount of effort to operate, generally two workers at a time. In mid- 1987, AT1 consultant Martin Fisher developed a modified version, the Bielenberg-Fisher (B-F) press, which was easier to use and more durable. It is more expensive because it requires more steel and machining [9].

Jaswant S. and P.C. Bargale [10] developed a small capacity double stage compression **screw press** for oil expression. They attempted to improve the existing screw presses by developing a suitable and efficient oil press device.

Screw presses use an electric motor to rotate a heavy iron shaft, which has flights, or worms built into it to push the seeds through a narrow opening. The pressure of forcing the seed mass through this slot releases part of the oil, which comes out through tiny slits in a metal barrel fitted around

the rotating shaft. Expeller have a continuous flow of seed through the machine in contrast to the hydraulic system described above, which uses small, individual packages or batches of seed. To release as much oil as possible, the seeds must be dried to rather low moisture content and exposure to high temperature causes darkening of the oil. It also causes some scorching or overheating of the meal. The meal contains protein which, if undamaged, may be used either for food for human, soy flour for example, or as feed for animals such as soybean meal. Because most press or expeller processes overheat the meal and leave too much of the high value oil in the seedcakes, methods of extracting the oil with solvents were developed. Seeds like soybeans with low oil content are processed by solvent methods alone.

Expellers work on the principle of a pressure differential applied to the incoming oilseeds versus that applied to the discharge material. The compression ratio of the screw/worm is therefore one of the most important criteria influencing the performance of a screw press. It is defined as the ratio of volume of material displaced per revolution of the shaft at the feed section to the volume displaced. However, the mechanical screw presses (oil expellers) are relatively inefficient, leaving about 8 to 14% of the available oil in the cake.

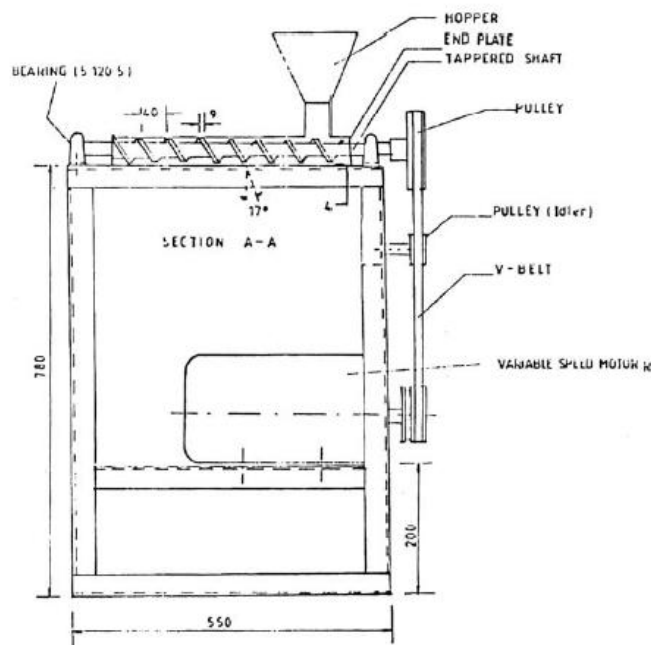

Fig. 2 Screw press

Isobe, Zuber, Uemura[11] and Noguchi in 1992 developed a **screw press based on twin screws** and reported an oil recovery of over 93% from untreated, dehulled sunflower seed. The objective of the work presented in this paper was to develop an efficient modified oil expeller based on a conceptual design. The design was conceived based on the experience of investigators while testing several of the existing local as well as imported oil expellers.

In this research principle of operation of screw press is discussed: The oil, in the form of oil globules, is present in the cells of the oilseed at different locations along with other constituents such as proteins, globoids and nucleus. These are surrounded by a tough membrane called cell wall. Oilseed medium is fed continuously into the screw press, where it is compressed under high pressure which ruptures the cell walls so that the oil globules can escape, and forces oil through the slits provided along the barrel length. The compressed solids are simultaneously discharged through a choke provided at the end of the barrel.

The **forward pitch screws** mainly ensure conveying action. The paddles exert a radial compression and shearing action on the matter but have limited mixing ability. In combination with forward pitch screws, the bi-lobe paddles exert significant mixing, shearing, conveying, and axial compression actions on the matter. The bi-lobe paddles are favorable to intimate mixing required in the liquid/solid extraction of soluble constituents in the cell structure. Finally, the reversed pitch screws carry out intensive shearing and considerable mixing on the matter, and exert a strong axial compression in combination with forward pitch screws [12]. The reversed pitch screws are frequently used to place pressure on the matter, which is essential for the separation of liquid and solid phases by filtration.

Mechanical expression using hydraulic presses is one of the ways by which oil is removed from oilseeds by the use of presses (Khan & Hannah, 1984). This method is generally preferred because of its lower initial and operational costs. It produces relatively uncontaminated oil as compared to the solvent extraction process and it allows the use of the cake residue [13].

J.C. Igbeka, T.J. Afolabi [14] presented oil yield from groundnut kernels in a **hydraulic press** using artificial neural network (ANN). In achieving the set goal of the study, an artificial neural Network (ANN) was trained and validated. A total of 96 data sets obtained from the experimental work of Olajide (2000) were used in this study. About 60 sets of these data sets we

assigned the training set while the remaining 36 sets were used as the validation sets. There are five input variables, which are: applied pressure (X1), pressing time (X2), moisture content (X3), heating temperature (X4) and heating time (X5). The desired output is the oil yield from the groundnut.

Another study by R.Supengcum, V.Phupha, and T.Natatan [15] examined the development of coconut oil pressing machine from old model to hydraulic cylinder system. In the operating principles, the developed machine uses the motor pumping the hydraulic oil into hydraulic pump, the oil flow was restricted by hydraulic pump to increase the pressure transmitted to the solenoid valve which is responsible for changing the direction of the oil flow, resulting that the cylinder moves up and down under the control system then the cylinder presses the coconut pulp.



Fig. 3 Coconut oil pressing machine

J.J. Mpagalile, M.A. Hanna [16] studied Seed oil extraction using a **solar powered screw press**. A bridge type screw press operated by a 190W, 12V DC motor connected to solar photovoltaic panels with 12Vdc energy storage batteries was designed and used in pressing trials shown in the figure below. Each battery had a 75Ah storage capacity and four batteries were connected in

parallel. The machine screw actuator was connected to the motor using a gear assembly. The machine screw actuator was an inverted unit with a 907 kg load, 600mm extension rating.

In this study, a photovoltaic operated oil expeller was designed, fabricated, and tested using oilseeds at an intermediate moisture content of  $12\pm 1\%$ . The press was designed based on the principle of a bridge press. The paper presented also the press performance evaluation from the oil expression efficiency and the energy consumption.

The press performance was evaluated from the oil expression efficiency and the energy consumption. The oil expression efficiency was calculated from the amount of extracted oil to the oil available in the sample. The analyses of the oil available in the oilseeds were carried out using a Soxhlet extraction apparatus [17].

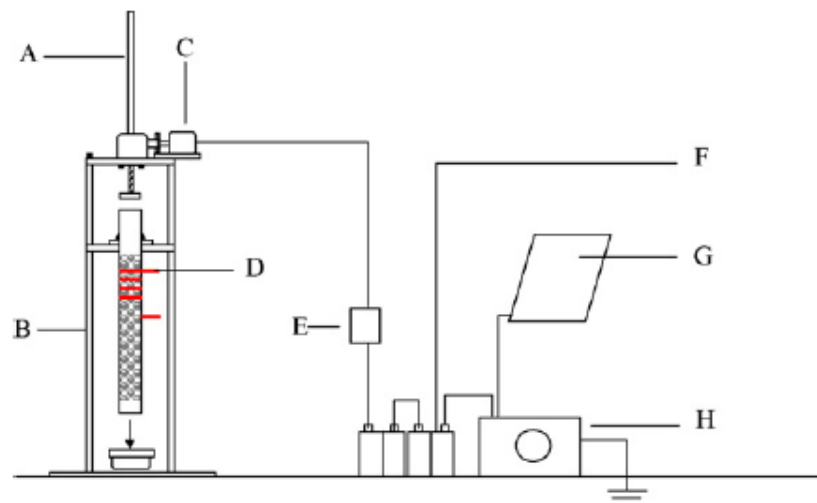

Fig.4 Solar powered screw oil press

J.P.Modak and A. D. Dhale [18] developed **human powered process machines** which energized process units needing 3 to 7 kW and which have intermittent operation. Mechanical transmission of this machine comprises of spiral jaw clutch and torque amplification gear pair. and the process units used are for brick making, wood turning, Algae formation machine, wood strips cutter and Smiths hammer and electricity generation.

The human input energy was given to the flywheel to reach its required speed. As the required speed was obtained the clutch was engaged to communicate from the shaft of the flywheel to the shaft of the process unit. As soon as the energy was transferred, the shaft of the oil press rotated and oil seed got pressed in between the tapered portion of the press shaft and inner surface of the barrel of the oil press.



Fig.5 Oil press using human powered flywheel motor

### **3. Methodology**

#### **3.1 Methods**

The methods to be employed to achieve the objective of the thesis are broken down in to different phases.

##### **Data collection**

As it is already described in the above sections this thesis is about design of small oil press machine. In this thesis to accomplish the proposed ideas the first step is searching of literatures concerning oil seed and their properties and different oil press machines to identify parts and the working principle of various oil press machines. After exploring this data the next step is collecting diverse data concerning parts of the machine and design procedure of those parts. This process of data collection will be accomplished by:-

- Information gathering from different agricultural machine manufactures and research centers.
- Information from different literature on this area.

#### **3.2 Materials**

##### **Mechanical design of components**

In the design part different parts of the machine will be designed and optimization of parameters of the components of the machine will be done. In this section design of the following parts will be done:

- Design of gear system, i.e. rack and pinion gear
- Design of shaft
- Selection of appropriate bearings
- Housing
- Dimension of the press, the base part of the press and other small parts of the machine is also calculated.
- Material selection of oil filter

### **Power supply unit/control system**

The other part of this thesis is selection of an appropriate electric motor type, specifying power and torque for proper and safe operation, since it is the power source of the machine. The controlling method i.e. control of changing directional movement of the machine will be discussed and incorporate the system with Mechatronics controlling mechanism.

### **Stress analysis**

After completing the design part, stress analysis will be performed using finite element Analysis.

### **Modeling of parts and Assembly**

Finally modeling of different parts of the machine and the assembly will be done by using Solid work or Catia V<sub>5</sub> software using results obtained from the design part.

## **4. Design of electric motor driven mechanical oil press**

### **4.1 Design features**

During designing following points are considered:

- The design should be simple and the construction should be at minimum cost.
- Power requirement to operate the equipment should be minimal. This is to be achieved by providing means for efficient power utilization.
- The component parts should be easily replaceable in case of any damage.

It is necessary to evolve physical design of an experimental set up having provision of setting test points. In fact, determination of such values of independent variables is a complex phenomenon of interaction of various independent variables such as parameters of the oil press such as speed of the rotation of shaft, the amount of oil seed taken and the response variables would be time of pressing, instantaneous torque on the shaft, quantity of oil extracted. It is well known that mathematical modeling of any man-machine system is possible by applying methodology of different design approaches.

### **4.2 Design analyses**

In the design analysis part the following components of oil press will be designed for optimum and safe operation.

The oil press is made up of the following components:

- Electric motor
- Ram disc
- Shaft
- Gear system
- Oil filter

### 4.3 Design of Gear system

Gear is a toothed wheel mechanical device used to transmit power and motion between machine parts. Teeth of driving gear mesh accurately in the space between teeth on the driving gear.

Rack and pinion: a rack and pinion is a spur pinion on a shaft that engages a flat, straight spur gear. Rack and pinions are used to convert rotary motion to linear motion. One common application for a rack and pinion is the raising and lowering or spindle of a drill press.

This is a specialized form of spur gear where the spur meshes with gear teeth on a flat rack. The function of this device is to bring about a reciprocating motion. A rack is a straight gear that moves linearly instead rotating. When a circular gear is mated with a rack, the combination is called rack and pinion drive. The rack is essentially a spur gear with an infinite radius.

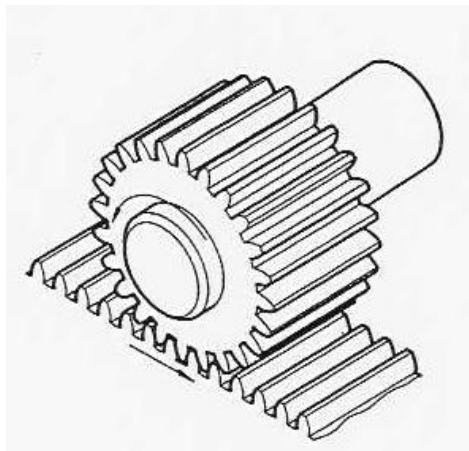

Fig.6 Rack and pinion gear

#### 4.3.1 Design of pinion

This design of gear is done based on Lewis formula. The formula was announced in 1892, and it still remains the basis for most gear design today. By using Lewis equation we can find stress and select appropriate material for gear.

Before starting the design analysis first let's define some nomenclature of the gear:

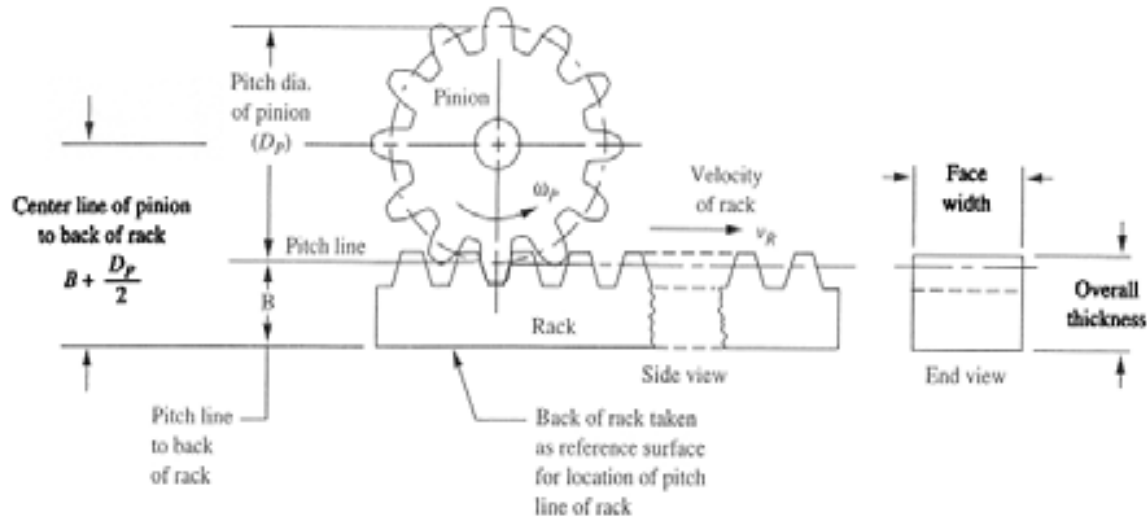

Fig.7 Nomenclature of Rack and pinion

- The module  $m$  is the ratio of the pitch diameter to the number of teeth. The customary unit of length used is the millimeter. The module is the index of tooth size in SI.
- The diametral pitch  $P$  is the ratio of the number of teeth on the gear to the pitch diameter. Thus, it is the reciprocal of the module. Since diametral pitch is used only with U.S. units, it is expressed as teeth per inch.
- The addendum  $a$ : is the radial distance between the top land and the pitch circle.
- The dedendum  $b$ : is the radial distance from the bottom land to the pitch circle. The whole depth  $h_t$  is the sum of the addendum and the dedendum.

Input data:-

Speed of driving shaft (Motor's rotational speed in rpm) = 550 rpm, selected motor type. This will be discussed on the controlling system part.

Assumption:-

- Gear ratio,  $i=1.5$
- Number of teeth on pinion,  $Z_p=18$
- Module,  $m=2$
- Power=100W
- Factor of safety ,  $F.S=2.0$
- Face width = 7mm

Required:-

- ✓ Dimensions of the pinion
- ✓ Check the safety of the gear for bending and pitting resistance.

Analysis:-

The Lewis formula

$$\sigma = \frac{W_t}{K_v F m Y} \dots\dots\dots 1$$

Where:  $\sigma$  = stress in Mpa

$W_t$  = the tangential load

F = face width measured in mm

$K_v$  = the velocity factor

Y = Lewis form factor

Now let's find each value on Lewis equation

➤ Tangential load

$$W_t = \frac{60P}{2\pi n_p r_p} * 10^3 \dots\dots\dots 2$$

Where p = power

$r_p$  = radius of the pinion

$n_p$  = speed of the pinion

To find radius of the pinion we have

$$D_p = m * Z_p = 2 * 18 \text{mm} = 36 \text{mm}$$

$$\text{So } r_p = \frac{D_p}{2} = \frac{36}{2} = 18 \text{mm}$$

And the speed of pinion is equal to the speed of driving shaft. So that  $n_p = 550\text{rpm}$

$$W_t = \frac{60 \cdot 100}{2H \cdot 550 \cdot 18} = 96.46\text{N}$$

➤ Velocity factor,  $K_v$

$$K_v = \frac{3.05}{3.05 + v} \dots\dots\dots 3$$

Where  $v$  = pitch line velocity in m/s

$$V = \frac{2Hd_p N_p}{60} = \frac{2H \cdot 36 \cdot 550}{60} = 2.07\text{m/s}$$

$$\text{So } K_v = \frac{3.05}{3.05 + 2.07} = 0.596$$

➤ Lewis form factor

Value of Lewis form factor is read from table using number of teeth of pinion.

*Table 1 Values of the Lewis Form Factor Y*

Number of Teeth	Y	Number of Teeth	Y
12	0.245	28	0.353
13	0.261	30	0.359
14	0.277	34	0.371
15	0.290	38	0.384
16	0.296	43	0.397
17	0.303	50	0.409
18	0.309	60	0.422
19	0.314	75	0.435
20	0.322	100	0.447
21	0.328	150	0.460
22	0.331	300	0.472
24	0.337	400	0.480
26	0.346	Rack	0.485

From the above table corresponding value of Lewis Form Factor Y for  $Z_p = 18$  is 0.309

$$Y = 0.309$$

Substituting these values into equation (1)

$$\sigma = \frac{94.46}{0.596 * 7 * 2 * 0.309} = 36.64 \text{Mpa}$$

Finding allowable stress,  $\sigma_{\text{all}}$

$$\sigma_{\text{all}} = F.S * \sigma = 2 * 36.64 \text{Mpa} = 73.28 \text{Mpa}$$

Pinion material's allowable strength should be greater than 73.28Mpa. Using this obtained allowable strength material will be selected.

### **Material selection**

The selection of a proper material, for engineering purpose, is one of the most important stages. The best material is one which serves the most important stage. The best material is one which serves the desired objective at the minimum cost. The following factors should be considered while selecting material:

- ✓ Availability of the material
- ✓ Suitability of the material for working condition in service
- ✓ the cost of material
- ✓ processing of material by the available technology

Using obtained allowable stress Steel with  $\sigma_{\text{all}} = 85 \text{Mpa}$  is selected.

Gear material: Gears are made of ferrous, non-ferrous metals and non metallic materials. However steel gears are predominantly used. Since steel has a capacity to be heat treated to various levels of hardness and strength, it has good wearing property and excellent machinability.

### Checking against bending and pitting

This analysis is done to resist bending failure of the teeth and to resist pitting or failure of the tooth surface. Failure by bending will occur when the significant tooth stress equals or exceeds either the yield strength or the endurance limit. A surface failure occurs when the significant contact stress equals or exceeds the surface endurance strength.

#### i. Bending stress

The fundamental formula for bending stress is given by

$$\sigma = \frac{W_t K_a}{K_v} * \frac{1}{F m} * \frac{K_s K_m}{J} \dots\dots\dots 4$$

Where  $\sigma$ - bending stress

$W_t$ - Transmission tangential load

$K_a$ - Application factor

$K_v$ - Dynamic factor

m - Module

F - Face width

$K_s$ - Size factor

$K_m$ - load distribution factor

J - Geometry factor

Now let's find value for each term

- $W_t = 96.46\text{N}$  .....previously obtained value
- Application factor,  $K_a$ : the purpose of application factor is to compensate for the fact that situation arise where the actual load exceeds the nominal tangential load. [Howard B. Schwerdlin]. Take  $K_a = 1$
- Dynamic factor,  $K_v$ : Dynamic factors are used to account for in accurate in the manufacture and meshing of gear teeth in action.

$$K_v = \left[ \frac{A}{A + (200v)^{1/2}} \right]^B \dots\dots\dots 5$$

$$A = 50 + 56(1 - B)$$

$$B = \frac{(12 - Q_v)^{2/3}}{4}$$

$Q_v$  = the AGMA transmission accuracy level number

$v$  = Pitch line velocity

AGMA has defined a set of quality control numbers. These numbers define the tolerance for gears of various size manufactured to specified quality class.

Class 3-7 include most commercial quality gears

Class 8-12-precision quality

Let's take  $Q_v = 8$

Substituting the value  $B = \frac{(12 - 8)^{2/3}}{4} = 0.629$

$$A = 50 + 56(1 - 0.629) = 70.776$$

So that  $K_v = \left[ \frac{70.776}{70.776 + (200 \cdot 2.07)^{1/2}} \right]^{0.629} = 0.3604$

- Size factor,  $K_s$ : the AGMA recommendation is to use a size factor of unity. For most gears provided a proper choice of steel is made for the size of the part and the heat treatment and hardening process.

$$K_s = 1$$

- Load distribution factor,  $K_m$  : is used to account for
  - Misalignment of rotational axes for any reason
  - Load caused elastic deflection of shafts ,bearing/housing

AGMA present two methods, one empirical and the other analytical, of obtaining values for the load distribution factor. AGMA acknowledges that the empirical method gives results similar to those obtained in standards.

$K_m$  value obtained from standard table.

$K_m=1.3$  for face width  $\leq 50\text{mm}$  and for condition of support, accurate mounting, low bearing clearance, minimum deflection and precision gear. [Km table, Appendix E]

- Geometry factor, J : obtained from figure on appendix A[Source AGMA 218.01]

For  $Z_p=18$  and number of teeth on mating gear, number of teeth on the rack which is equal to 12,  $J=0.26$

Substituting these values into equation 4

$$\sigma = \frac{96.46 * 1}{0.3604} * \frac{1}{7 * 2} * \frac{1 * 1.3}{0.26}$$

$$\sigma = 95.59 \text{ Mpa}$$

To compare bending stress with the allowable stress let's calculate  $\sigma_{all}$ .

$$\sigma_{all} = \frac{S_t K_l}{K_t K_r} \dots\dots\dots 6$$

Where  $\sigma_{all}$  - allowable bending stress

$S_t$  - AGMA bending strength

$K_l$  - Life factor

$K_t$  - Temperature factor

$K_r$  - Reliability factor

- AGMA bending strength,  $S_t$  – since we select material with  $\sigma_{all} = 85\text{Mpa}$ .  $S_t$  can be in range of (80-110Mpa) [From AGMA strength table, See appendix C] so take  $S_t = 85\text{Mpa}$ .
- Temperature factor,  $K_t$  for temperature up to  $250^{\circ}\text{F}$  or  $120^{\circ}\text{C}$  use ,  $K_t = 1.0$
- Reliability factor,  $K_r$  : assume the reliability  $R=0.9$  and read corresponding value of reliability factor form table of AGMA reliability factor.  $K_r=0.85$

Table 2 AGMA reliability factor

Reliability	$K_R (Y_Z)$
0.9999	1.50
0.999	1.25
0.99	1.00
0.90	0.85
0.50	0.70

- Life factor  $K_L$  : AGMA strength is based on  $10^7$  tooth load cycle, defined as the number of mesh under load. For this design assume that  $10^7$  cycles and life cycle for this amount is 1.0. The purpose of the tooth life factor is modifying the AGMA strength lives other than  $10^7$ .

$K_L = 1.0$  is taken.

Substituting values in to equation (6)

$$\sigma_{all} = \frac{85 \text{Mpa} * 1}{1 * 0.85} = 100 \text{Mpa}$$

$$\sigma < \sigma_{all}$$

$$95.59 \text{Mpa} < 100 \text{Mpa}$$

Failure by bending will occur when the significant tooth stress equals or exceeds either the yield strength or the allowable strength. Based on this definition tooth stress is less than allowable strength so that the gear is safe for bending of teeth.

## ii. Pitting resistance

Pitting is the process during which small pits are formed on the active surface of gear teeth. Pitting is essentially a fatigue failure and it does not occur in the initial stages of operation. Cracks which culminate into pits, first form in the region of line of action where the velocity of sliding is minimum and force of friction and stress are maximum.

It is a surface fatigue failure resulting from repetitions of high contact stress. The surface fatigue mechanism is not definitively understood. The contact affected zone, in the absence of surface shearing tractions, entertains compressive principal stresses. Rotary fatigue has its cracks grown at or near the surfaces in the presence of tensile stresses, which are associated with crack propagation, ends to catastrophic failure.

When loads are applied to the bodies, their surfaces deform elastically near the point of contact; so that a small area of contact is formed. It is assumed that, as this small area of contact forms, points that come into contact are points on the two surfaces that originally were equal distances from the tangent plane [19]. Pitting commonly appears on operating surfaces of gear teeth, a fundamental cause is excessive loading that raised contact stresses beyond critical levels.

In the following analysis we are going to check safety of the gear against pitting.

$$\sigma_c = C_p \left( \frac{WtC_a}{C_v} * \frac{C_s}{F d_p} * \frac{C_m C_f}{I} \right)^{1/2} \dots\dots\dots 7$$

Where  $\sigma_c$ =contact stress

$C_p$ =Elastic coefficient

$C_a$ =Application factor

$C_v$ = Dynamic factor

$C_s$ =Size factor

$d_p$ =Diameter of pinion

$C_m$ =Load distribution factor

$C_f$ =Surface condition factor

$I$ =Geometry factor for pitting

- Elastic coefficient,  $C_p$ : can be obtained from table [20].

Table 3 Elastic coefficient

Pinion Material	Pinion Modulus of Elasticity $E_D$ psi (MPa)*	Gear Material and Modulus of Elasticity $E_G$ , lbf/in <sup>2</sup> (MPa)*					
		Steel $30 \times 10^6$ ( $2 \times 10^5$ )	Malleable Iron $25 \times 10^6$ ( $1.7 \times 10^5$ )	Nodular Iron $24 \times 10^6$ ( $1.7 \times 10^5$ )	Cast Iron $22 \times 10^6$ ( $1.5 \times 10^5$ )	Aluminum Bronze $17.5 \times 10^6$ ( $1.2 \times 10^5$ )	Tin Bronze $16 \times 10^6$ ( $1.1 \times 10^5$ )
Steel	$30 \times 10^6$ ( $2 \times 10^5$ )	2300 (191)	2180 (181)	2160 (179)	2100 (174)	1950 (162)	1900 (158)
Malleable iron	$25 \times 10^6$ ( $1.7 \times 10^5$ )	2180 (181)	2090 (174)	2070 (172)	2020 (168)	1900 (158)	1850 (154)
Nodular iron	$24 \times 10^6$ ( $1.7 \times 10^5$ )	2160 (179)	2070 (172)	2050 (170)	2000 (166)	1880 (156)	1830 (152)
Cast iron	$22 \times 10^6$ ( $1.5 \times 10^5$ )	2100 (174)	2020 (168)	2000 (166)	1960 (163)	1850 (154)	1800 (149)
Aluminum bronze	$17.5 \times 10^6$ ( $1.2 \times 10^5$ )	1950 (162)	1900 (158)	1880 (156)	1850 (154)	1750 (145)	1700 (141)
Tin bronze	$16 \times 10^6$ ( $1.1 \times 10^5$ )	1900 (158)	1850 (154)	1830 (152)	1800 (149)	1700 (141)	1650 (137)

Elastic coefficient for steel material =191

- Application factor,  $K_a = C_a$  so that  $C_a = 1$
- Dynamic factor,  $K_v = C_v$  the value of  $K_v$  is calculated previously in equation (5)

$$\text{So } C_v = 0.3604$$

- Size factor,  $C_s$ : AGMA recommendation is to use a size factor of unity.
- Surface condition factor,  $C_f$ : AGMA has not yet established value for the surface factor, but suggest value is unity.  $C_f = 1$
- Face width,  $F = 7\text{mm}$
- Diameter of the pinion,  $d_p = 36\text{mm}$ (previously obtained value)
- Load distribution factor,  $C_m = 0.26(K_m = C_m)$
- Geometry factor for pitting,  $I$  can be obtained the following formula[equation14.23 [20]]

$$I = \frac{\cos\phi t * \sin\phi t}{2m_N} * \frac{m_G}{m_G + 1}$$

Where  $m_G$  is gear ratio which is equal to module so  $m_G = 2$

$\phi t$  :is pressure angle= $20^\circ$

$m_N$ : is the load sharing ratio

$m_N = 1$  for spur gear

$$I = \frac{\cos 20 \cdot \sin 20}{2 \cdot 1} \cdot \frac{2}{2+1} = 0.107$$

Substitute all these values into equation (7)

$$\sigma_c = 506.84 \text{ Mpa}$$

Now let's find allowable contact stress to compare with previously obtained contact stress to check whether it is safe or not against pitting.

Allowable contact stress:

$$\sigma_{c,all} = \frac{S_c \cdot C_l \cdot C_H}{C_T \cdot C_R} \dots\dots\dots 8$$

$C_l$  = life factor

$C_h$  = hardness ratio factor

$C_t$  = temperature factor

$C_r$  = reliability factor

$S_c$  = AGMA surface endurance strength [20]

Finding each value:

- AGMA surface endurance strength,  $S_c$  obtained from AGMA fatigue strength table,  $S_c$  see Appendix B for selected material which have hardness of 180BHN

$$S_c = 470 \text{ Mpa}$$

- Life factor,  $C_l$  can be obtained using the following procedure

$$C_L = 2.466(n)^{-0.056}, \quad n = 550 \text{ rpm}$$

$$= 2.466 \cdot (550)^{-0.056}$$

$$= 1.732$$

- Temperature factor,  $C_t = K_T = 1$

- Hardness ratio factor,  $C_h$

$$C_h = 1 + A(m_G - 1), m_G = 2$$

$$A = 8.98(10^{-3}) * (HBP/HBG) - 8.29(10^{-3})$$

HBP= hardness of the material for the pinion is selected from table (material selection for the gear according to velocity=2.07m/s: previously obtained value)

$$HBP=180BHN$$

Assume that pinion and wheel is made from same material i.e.  $H_{BG} = H_{BP}$

$$\text{So } A = 6.9 * 10^{-4}$$

Substitute in to  $C_H$ ,

$$C_H = 1 + 6.9 * 10^{-4}(2-1) = 1.00069 = 1.0$$

- Reliability factor ,  $C_R = K_R = 0.85$

Now substitute these values in it allowable contact stress formula;

$$\sigma_{c,all} = 828.36 \text{Mpa}$$

$$\sigma_c < \sigma_{c,all}$$

$$506.84 \text{Mpa} < 828.36 \text{Mpa}$$

So the gear is safe against pitting

Table 4 Summarized result of design of gear

Parameters	Values
Number of teeth	18
Module [mm]	2
Pressure angle ( $^{\circ}$ )	20
Addendum [mm]	2
Dedendum [mm]	2.5
Face width[mm]	7

#### 4.3.2 Rack

The rack is essentially a spur gear with an infinite radius.

During designing of pinion the following two conditions have been fulfilled

- Very good pitch accuracy and
- Sufficient tolerance of meshing conditions

Now in this section parameters of the rack are determined which are suitable for the dimensions obtained in design of pinion.

There is a standard table for selecting rack parameter according to the number of teeth of the pinion. From this table, see Appendix D, the following parameters are obtained:

Number of teeth of pinion is 18 for this value:-

- ✚ Number of rack is 12
- ✚ Rack Length is 150mm
- ✚ Rack Face width is 2.0mm

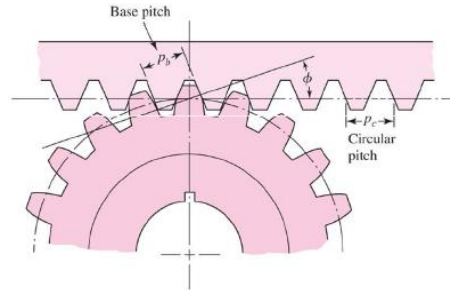

Fig.8 Rack teeth geometry

#### 4.4 Shaft Design

A shaft is a rotating member, usually of circular cross section, used to transmit power or motion from one place to another. Power is delivered to the shaft by some tangential force and resulting torque (or twisting moment) set up within the shaft permits the power to be transferred to various machines linked up to the shaft. It provides the axis of rotation, or oscillation, of elements such as gears, pulleys, flywheels, cranks, sprockets, and the like and controls the geometry of their motion.

The shaft is subject to torsion, bending, and occasionally axial loading. Stationary and rotating members, called axles, carry rotating elements, and are subjected primarily to bending. Transmission or line shafts are relatively long shafts that transmit torque from motor to machine. Countershafts are short shafts between the driver motor and the driven machine. Head shafts or stub shafts are shafts directly connected to the motor.

Regardless of design requirements, care must be taken to reduce the stress concentration in notches, keyways, etc. Proper consideration of notch sensitivity can improve the strength more significantly than material consideration. Equally important to the design is the proper consideration of factors known to influence the fatigue strength of the shaft, such as surface condition, size, temperature, residual stress, and corrosive environment.

### Analysis for design of shaft

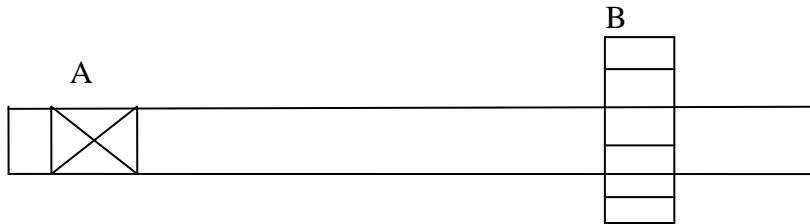

Fig.9 Components on shaft

### Force analysis

In force analysis of shaft there are three types of load on shaft which are tangential load, axial load and radial load. But axial load is necessary with helical and bevel gear. In cases where axial loads are not trivial, it is necessary to provide a means to transfer the axial loads into the shaft, then through a bearing to the ground. This will be particularly necessary with helical or bevel gears, or tapered roller bearings, as each of these produces axial force component.

So in this case shaft force analysis will be done using two components of the load.

i.e. tangential and radial load

- Tangential load,  $W_t=96.46\text{N}$ , previously obtained value
- Radial load,  $W_r$

$$W_r = W_t * \tan \alpha \cos \gamma$$

$\alpha=20^\circ$  degree for involutes system

$$\gamma = \tan^{-1}(d_p/d_w)$$

$d_p$  = diameter of pinion = 36mm

$d_w$  = diameter of wheel, it is diameter of rack in this case

$d_w$  = infinity because rack is spurs gear with an infinite radius.

$$\gamma = \tan^{-1}(36/\infty) = \tan^{-1}(0) = 0$$

$$W_r = W_t * \tan 20 \cos 0 = 35.11 \text{ N}$$

Free body diagram of shaft



To find  $R_{Ay}$  and  $R_{Ax}$  take summation of force in the X and Y axis:

Summation of all forces in the x- direction:

$$\Sigma F_x = 0$$

$$R_{Ax} - W_r = 0 \Rightarrow R_{Ax} = W_r = 35.11 \text{ N}$$

Summation of all forces in the y- direction:

$$R_{Ay} - W_t = 0 \Rightarrow R_{Ay} =$$

$$W_t = 96.46 \text{ N}$$

Now bending moment and shear force diagram will be drawn to find maximum moment

Moment along Y

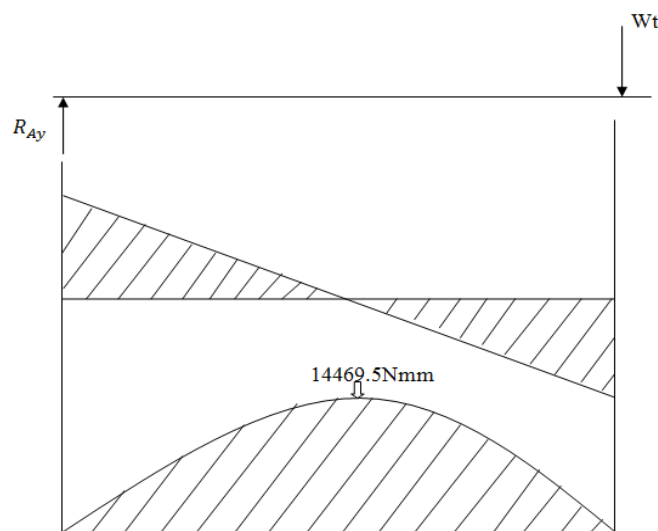

Moment along X

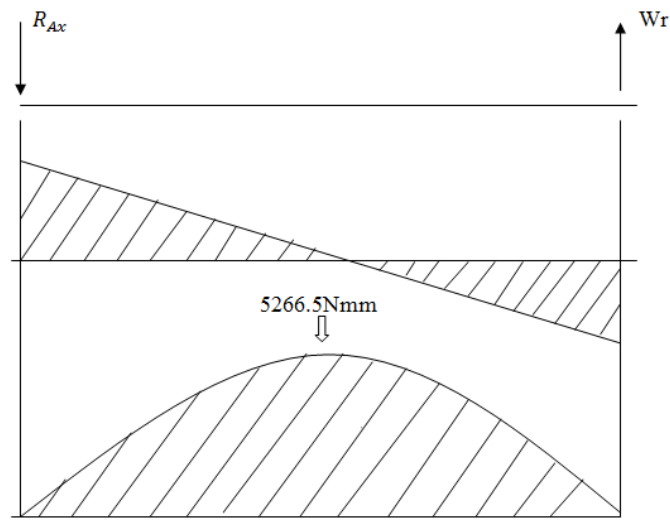

Fig.10 Shear force and bending Moment diagram

From the above shear force and bending Moment diagram let's find the resultant moment:

Moment along X-axis  $M_x = 5266.5Nmm$

Moment along y-axis  $M_y = 14469Nmm$

- Resultant moment,  $M_R = \sqrt{M_x^2 + M_y^2}$   

$$= \sqrt{5266.5^2 + 14469^2}$$

$$= 15397.6Nmm$$
- Torque,  $T = W_t * r_p = 96046N * 18mm = 1736.28Nmm$

Diameter of the shaft can be calculated by two different formulas: Using equivalent twisting moment formula and using equivalent bending moment formula.

Equivalent twisting moment formula

$$T_e = \sqrt{(K_m * M)^2 + (K_t * T)^2}$$

Where  $K_m$  and  $K_t$  are combined shock and fatigue factors for bending and torsion respectively

$K_m$  and  $K_t$  are taken as  $K_m=1.5$  and  $K_t=1.5$

$$T_e = \sqrt{(1.5 * 15397.5)^2 + (1.5 * 1736.28)^2}$$

$$T_e = 23242.6 \text{ Nmm}$$

We also know that equivalent twisting moment ( $T_e$ )

$$T_e = \frac{\pi \tau_{all} d^3}{16}$$

Taking factor of safety,  $F.S = 2.5$

Material selection

Material used for shafts are carbon and alloy steel that have the following properties.

- High strength
- Good machinability
- Low notch sensitivity factor
- Good heat treatment property
- High wear resistance property

Select material steel with  $\sigma_{all} = 150 \text{ Mpa}$

Let's find  $\tau_{all}$

$$\sigma_{all} = 150 \text{ Mpa}$$

$$\sigma_y = F.S \sigma_{all} = 2.5 * 150 \text{ Mpa} = 375 \text{ Mpa}$$

$$\tau_y = \sigma_y / 2 = 375 / 2.5 = 150 \text{ Mpa}$$

$$\tau_{all} = \tau_y / F.S = 150 / 2.5 = 60 \text{ Mpa}$$

Now substitute into  $T_e$

$$d^3 = \frac{16T_e}{\pi\tau_{all}} = \frac{16 \cdot 23242.6 \text{ Nmm}}{\pi \cdot 60 \text{ N/mm}^2}$$

$$d = 12.542 \text{ mm}$$

For safety take diameter of shaft  $d = 15 \text{ mm}$

### 4.5 Bearing Selection

A bearing is a device to allow constrained relative motion between two or more parts, typically rotation or linear movement. Bearings may be classified broadly according to the motions they allow and according to their principle of operation as well as by the directions of applied loads they can handle.

*Table 5 Dimensions and Load Ratings for Single-Row 02-Series Deep-Groove and Angular Contact Ball Bearings*

Bore, mm	OD, mm	Width, mm	Fillet Radius, mm	Shoulder		Load Ratings, kN			
				Diameter, mm	$d_s$	$d_H$	Deep Groove		Angular Contact
						$C_{10}$	$C_0$	$C_{10}$	$C_0$
10	30	9	0.6	12.5	27	5.07	2.24	4.94	2.12
12	32	10	0.6	14.5	28	6.89	3.10	7.02	3.05
15	35	11	0.6	17.5	31	7.80	3.55	8.06	3.65
17	40	12	0.6	19.5	34	9.56	4.50	9.95	4.75
20	47	14	1.0	25	41	12.7	6.20	13.3	6.55
25	52	15	1.0	30	47	14.0	6.95	14.8	7.65
30	62	16	1.0	35	55	19.5	10.0	20.3	11.0
35	72	17	1.0	41	65	25.5	13.7	27.0	15.0
40	80	18	1.0	46	72	30.7	16.6	31.9	18.6
45	85	19	1.0	52	77	33.2	18.6	35.8	21.2
50	90	20	1.0	56	82	35.1	19.6	37.7	22.8
55	100	21	1.5	63	90	43.6	25.0	46.2	28.5
60	110	22	1.5	70	99	47.5	28.0	55.9	35.5
65	120	23	1.5	74	109	55.9	34.0	63.7	41.5
70	125	24	1.5	79	114	61.8	37.5	68.9	45.5
75	130	25	1.5	86	119	66.3	40.5	71.5	49.0

For the shaft diameter  $D=15\text{mm}$ ,

Outside diameter of bearing (OD) = 35mm

Width=11mm

Fillet radius=0.6mm

Deep groove, C10=7.80KN

C0=3.55KN

Angular contact, C10= 8.06KN

C0=3.65KN

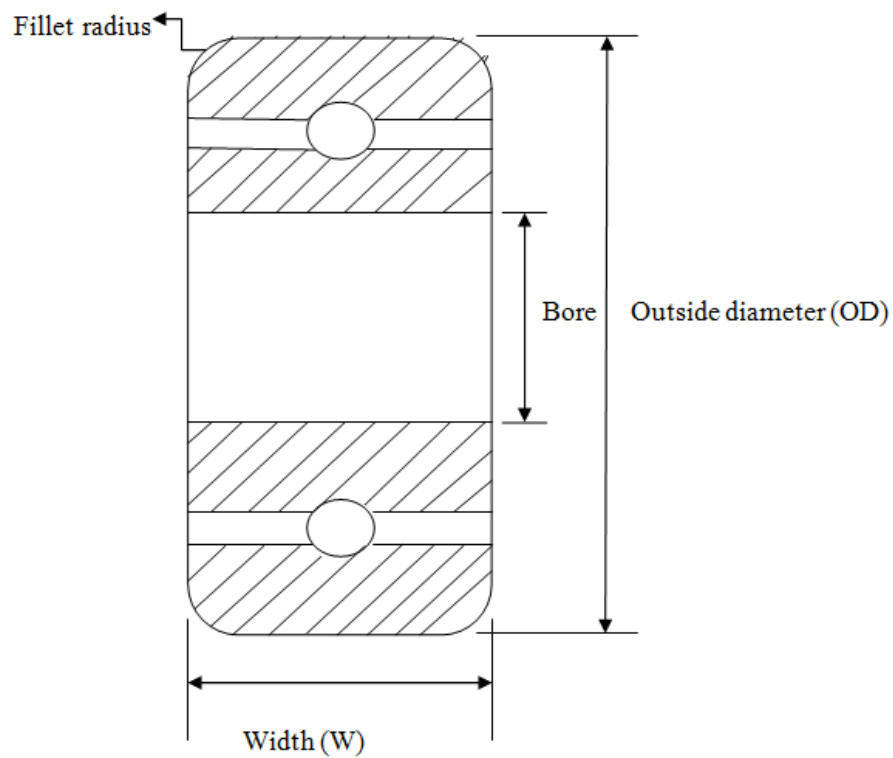

Fig.11 bearing nomenclature

#### **4.6 Design of power press/ Ram**

A press is working tool with a stationary bed and a powered ram can be driven towards the bed or away from the bed to apply force or required pressure for various types of operations. For this system of oil press machine ram press is a mechanical device used to squeeze oil seed on the base. The device consists of a static table mounted below the moving powered press. These parts are described below. And for this system of mechanical oil press Rack and pinion driven presses are called rack and pinion press is used.

Ram press is a long pivoted lever moves a piston backwards and forwards inside a cylindrical cage constructed from metal bars spaced to allow the passage of oil. When the piston is moved forward, the entry port is closed and the oilseed is compressed in the cage. As a result, oil is expelled from the oilseed and emerges through the gaps in the cage; compressed seed is pushed out through a circular gap at the end of the cage.

Base: Base is one of the parts of a press. It is main supporting member for work piece holding dies and different controlling mechanisms of press.

Ram/press: This is main operating part of the press which works directly during processing of a work piece to get oil from oil seeds by squeezing the oil seeds on the base or on the bed of the press. Ram reciprocates to and from within its guide ways with prescribes stroke length and power. The stroke length and power transferred can be adjusted as per the requirements. Ram at its bottom end carries punch to process the work piece.

- **Material for press**

Oil press machine designed in this thesis is used to produce edible oil so that the material selected for the press must be safe from any corrosion or rust since the ram press has high contact with the process of producing oil by squeezing the oil seed.

For the ram press in this oil press stainless steel is selected due to:

- Stainless steel does not readily corrode, rust or stain with water as ordinary steel does, and it is corrosion-resistant steel.
- High oxidation-resistance in air at ambient temperature.
- The layer is impervious/resistant to water and air, protecting the metal beneath.
- It has low maintenance
- Stainless steels have exceptionally high elongations

### Design

The ram disc (working like a piston) is expected to compress the oil seed fed into the expressing chamber as a result of the axial pressure from the from rotation of motor, the material being extracted at the same time exert a pressure equal but opposite on the point face.

This force and pressure considerations necessitate the choice of a rigid and strong material for the point. A stainless steel of 200mm in diameter and 60mm long is chosen.

The weight of the piston,  $W_P = S_p * V_P * g$

$S_p =$  density of ram disc material =  $7800\text{kg/m}^3$

$V_P =$  volume of piston

$$= \pi (0.2)^2 \times 0.06/4$$

$$= 1.84 \times 10^{-3} \text{m}^3$$

Therefore,  $W_P = 7800 \times 1.84 \times 10^{-3} \times 9.81$

$$= 137.7\text{N}$$

### 4.7 Oil filter sheets

Oil filter is fined sheet metal that is placed on the upper part of oil tank to separate some unwanted particles like husk of oil seed, dry oil seeds and other particles from outside environment.

Numerous types of equipment have been designed to cope with the removing the unwanted particles of oil seed from the oil. Because of the oil press is used to produce edible oil the main focus while preparing or selecting of oil filter equipment is selection of proper material which is safe from any contaminations and also the filter sheet must place in the position, so that it is easy to assemble and un-assemble filter cloth. The filter cloth is easy to clean and it can be used for long time.

Filter sheets of very high filtration efficiency will always be the safest solution but may suffer from early blocking and contamination, hence, the correct choice of filter sheet for the task is vital.



Fig.12 Oil filter sheet

### **Material selection for oil filter sheet**

Stainless steel perforated Plate is best material for filtering any particles from the oil after oil seed is squeezed by the ram press. Stainless steel is selected over the other types of material is due to its property: Stainless steel does not readily corrode, rust or stain with water as ordinary steel does.

## 5. Control unit

Before going to deal about the control mechanism of motor to change its directional motion first the type of motor and controlling mechanism of the motor have to be briefly described.

### 5.1 Motor type

To make an oil press automatically operated the main element is an electric motor to start the operation and to continue pressing the oil seed. For the power source of the oil press electric DC motor is selected. The most common motors in microcontroller control for motion/movement control are DC motors. These motors are particularly versatile because both their speed and direction can be readily controlled; speed by the voltage or duty cycle of their power supply, and direction by its polarity.

Power=100KW

Rotational speed= 550rpm.

Direct-current (DC) motor is preferable over the other types due to:

- These motors are particularly versatile because both their speed and direction can be readily controlled; speed by the voltage or duty cycle of their power supply, and direction by its polarity.
- They are cheap and easy to control (rotational direction, start/stop, and speed).
- Varying the speed of the input sequence can exactly control the speed of the motor.
- They have ability to rotate in respond to each control pulse
- They have precise positioning and repeatability of movement.
- Standardized frame size and performance.
- Overload safe, Motor cannot be damaged by mechanical overload [21].

The DC motor is a machine that transforms electric energy into mechanical energy in form of rotation.

The operation of a DC motor requires the presence of the following elements:

- A control unit, a microcontroller, which supplies impulses the frequency of which is proportional to the speed of the motor. This applies equally to both directions of rotation;
- A driver
- A power supply

### **5.2 System operation**

As it is described earlier the operation of oil press is automatic or controlled by an electric motor. As the motor starts running the shaft on the motor and so as pinion which is assembled on the shaft rotates. Due to the rotation of the pinion, the mating gear or the rack starts to move up and down. But to make the movement of the rack in two directions, i.e. up and down, the motor have to change its direction of rotation.

For example when the motor rotate in clock wise direction the rack moves in the up direction and when the motor changes its direction and starts to move in counter clock direction, the reciprocating motion direction of rack also changes and start to move down ward.

To allow the motor to move in this type of rotation the controlling mechanism of rotational direction of the motor have to set. The controlling mechanism of oil press will be discussed in the following section.

### **5.3 Controlling mechanism**

Aim of dealing controlling mechanism is to achieve motor forward or clock wise and reverse or anti clockwise direction control using microcontroller and assembly language.

Material needed

- DC motor
- Microcontroller
- L293 motor driver

### 5.3.1 Microcontroller and motor driver

Interfacing DC motor to microcontroller forms an essential part in designing control unit of an oil press. Microcontroller-DC motor system has essentially two parts. These two essential parts are Microcontroller with the required software to control the motor and a suitable driver circuit. Most of the DC motors have power requirements well out of the reach of a microcontroller and more over the voltage spikes produced while reversing the direction of rotation could easily damage the microcontroller. So it is not wise to connect a DC motor directly to the microcontroller. The perfect solution is to use a motor driver circuit in between the microcontroller and the DC motor [22].

#### Microcontroller

Microcontroller is preferred due to the following reasons.

- ✓ They are versatile
- ✓ Their ease of programming
- ✓ The ability to execute a stored set of instructions to carry out user defined tasks.
- ✓ The ability to be able to access external memory chips to both read and writes data from and to the memory.
- ✓ They are small size and have broad function
- ✓ They are low cost
- ✓ Lesser power usage: Microcontrollers are generally built using a technology known as CMOS. This technology is a competent fabrication system that uses less power and is more immune to power spikes than other techniques.
- ✓ Their system is All-in-one (system on chip): A microcontroller usually comprises of a CPU, ROM, RAM and I/O ports, built within it to execute a single and dedicated task.

Microcontroller is a single integrated circuit(IC) containing specialized circuit and functions that are applicable to Mechatronics system design. It contains a microprocessor, memory, I/O capability and other on chip recourses. It is basically a microcomputer on a single integrated circuit.

Microcontrollers are attractive in Mechatronics system design since their small size and broad functionality allow them to be physically embedded in a system to perform all of the necessary control functions. An onboard microcontroller actuates motor based on the input.

CPU	RAM	ROM
I/O	Timer	Serial COM port

Fig.13 Components of microcontroller

Almost all of powerful and interesting devices are controlled using microcontrollers and the software running on them. Microcontrollers have programming devices that can download a compiled machine code file from a PC directly to the microcontroller, usually via the PC serial port and special purpose pins on the microcontroller.

### **8051 microcontroller**

The 8051 microcontroller is a very popular general purpose microcontroller widely used for small scale embedded systems. The 8051 is an 8-bit microcontroller with an 8-bit data bus and a 16-bit address bus. The 16-bit address bus can address a 64Kbyte code memory space and a separate 64K byte data memory space. The 8051 has 4K on-chip read-only code memory, and 128 bytes of internal Random Access Memory (RAM). The 8051 has two timers/counters, a serial port, 4 general purpose parallel input/output ports, and interrupt control logic with five sources of interrupts. Besides internal RAM, the 8051 has various special functions registers (SFR) such as the accumulator, the B register, and other control registers [23].

There are 3 basic "sizes" of the 8051: Short, Standard, and Extended. The Short and Standard chips are often available in DIP form, but the Extended 8051 models often have a different form factor, and are not "drop-in compatible". All these things are called 8051 because they can all be programmed using 8051 assembly language, and they all share certain features.

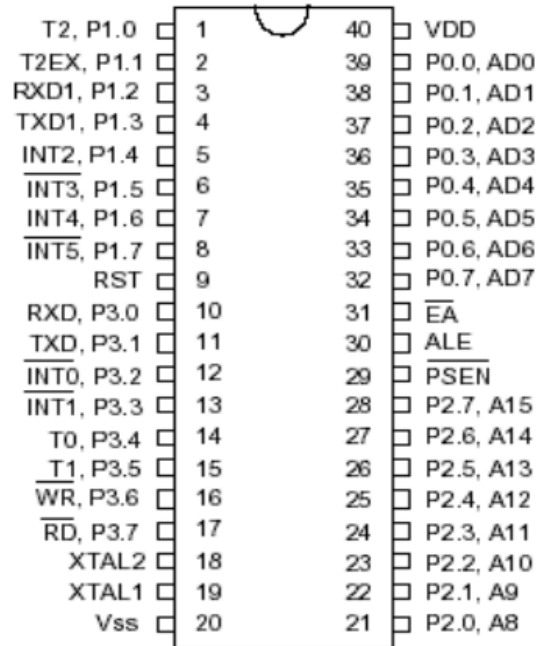

Fig.14 Pin Diagram of 8051

Advantage of 8051 microcontroller over the others

- 8051 microcontroller have the less complex features then other microcontroller
- It is also easily available and cheap in comparison of other microcontrollers
- Ease of implementing compensation algorithms
- Flexibility of optimizing design
- Small and cheap to fairly high performance

### 5.3.2 L293 motor driver

L293 is a dedicated quadruple Half H Bridge motor driver IC available in 16 pin package. L293 has a current capacity of 600mA/channel and has supply voltage range from 4.5 to 36V DC. They are fitted with internal high speed clamp diodes for inductive spike protection. L293 motor driver is used to energize the stator and to keep microcontroller (8051) from damaging. There are different types of motor driver circuit but for this case L293 type of motor driver is selected because of it has the following good features over the others:

- They are high noise immunity
- They have internal ESD protection
- Thermal shutdown
- Separate input supply for each channel etc.

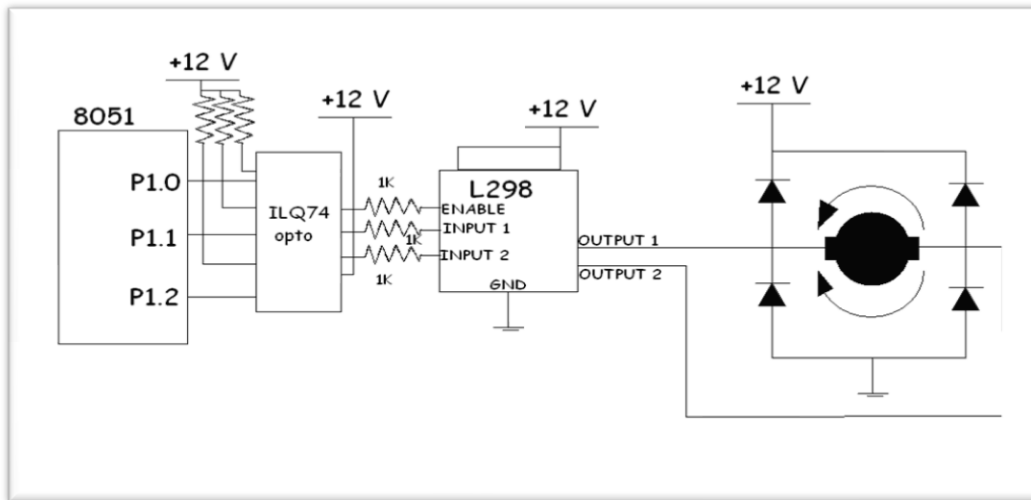

Fig.15 Interfacing of L298, motor and microcontroller

## 5.4 Programming for controlling DC motor

Since it is discussed in previous sections for controlled movement of stepper motor, to change different adverts on a specified time we need programming of microcontroller.

Program for controlling stepper motor is compiled and downloaded to a microcontroller; it is stored as a set of binary machine code instruction in the program memory. These instructions are sequentially fetched from memory, place in the instruction register and executed from memory. To use microcontroller in Mechatronics design program must be written, tested and stored in the ROM of microcontroller. Usually program is written and compiled using personal computer and then download to the microcontroller ROM as a machine code, the program can be written using assembly language.

### 5.4.1 Assembly language

Assembly languages sometimes called machine code are a type of low level language for programming computers, microprocessors, microcontrollers, and other integrated circuit. It is

essentially the native language of your computer. They implement a symbolic representation of the numeric machine codes and other constants needed to program a particular CPU architecture. When we say it is low level language that provides little or no abstraction from a computer's instruction. It also allows symbolic designation of memory locations.

Some assembly languages can be used to convert the code that programmers write (source code) into machine language (readable by the computer), and have functions to facilitate programming.

Advantage of assembly language

- Assembly language is useful for communicating with the machine at a hard ware level
- Other advantage is the size of the resulting programs because no conversion form a higher level by compiler is required; the resulting program can be exceedingly small.
- Possible to convey much information in a single
- Easy to code instruction
- Speed: Assembly language programs are generally the fastest programs around.
- Space: Assembly language programs are often the smallest.
- Capability: You can do things in assembly which are difficult or impossible in HLLs
- a straightforward way to translate programs written in assembly language into machine language

### 5.4.2 Assembly language written for 8051 microcontroller

A switch is connected to pin p2.7, it is one of the pin on the microcontroller which is connected to the DC motor, Write an assembly language program to monitor the status of the switch and perform the following:

- If SW=0 the stepper motor moves clockwise
- If SW=1 the stepper motor moves counterclockwise

ORG 0H; starting address

MAIN: SETB P2.7; make an input

MOV A, #66H; starting phase value

MOV P1, A; send value to port

TURN:

JNB P2.7, CW; check switch result

RR A; rotate right

ACALL DELAY; call delay

MOV P1, A; write value to port

SJMP TURN; repeat

CW:

RL A; rotate left

ACALL DELAY; call delay

MOV P1, A; write value to port

SJMP TURN; repeat

DELAY:

MOV R2, #100

H1: MOV R3, #255

H2: DJNZ R3, H2

DJNZ R2, H1

RET

END

## **6. Stress analysis**

### **6.1 Concept of stress analysis**

Stress analysis allows the calculation of different types of mechanical stresses and deformations. Stress analysis is specifically concerned with solid objects. Stress analysis adopts the macroscopic view of materials characteristic of continuum mechanics, namely that all properties of materials are homogeneous at small enough scales. Thus, even the smallest particle considered in stress analysis still contains an enormous number of atoms, and its properties are averages of the properties of those atoms.

Gears are one of the most critical components in mechanical power transmission systems. The bending and surface strength of the gear tooth are considered to be one of the main contributors for the failure of the gear in a gear set. Thus, analysis of stresses has become important part of the design of gears to minimize or to reduce the failures and for optimal design of gears.

The importance of stress analysis is focused on the determination of stress concentration regions that failure or fracture may initiate at these regions. Fracture of gear tooth can be predicted at tooth root area where tension stresses concentrate; hence cracks may initiate and propagate at root area when maximum generated stress at this area exceeds the yield stress. Moreover, pitting may occur due to stress concentration at contact area.

### **6.2 Why stress analysis**

An effective gear design balances strength, durability, reliability, size, weight and cost. However unexpected gear failure may occur even with adequate gear tooth design.

Gears which are very rigid develop high stress concentration at the root and contact point when subjected to loads. Due to these high stresses at the root and contact point there is a higher chance of fatigue failure at these locations. As the contact point shifts along the profile of the tooth a surface fatigue failure is more likely but the quick shifting of the load and enhanced material properties due to surface treatments means that this failure is not as critical. The repeated stress that occurs on the fillets is practically found to be the deciding factor in fatigue failure of the gear tooth. There is scope of improved design of gears by an introduction of stress relief features.

In high cycle fatigue situations, materials performance is normally characterized by the S-N curve. The graph depicts of a cyclical stress(S) against cycles to failures (N). Failure due to repeated loading is called fatigue. Fatigue failures are often caused by the degradation of metal surface. A rough surface finish, a scratch or oxidation will provide an initial crack. Cracks will propagate after cyclical loading and eventually lead to fatigue failure.

The importance of stress analysis is focused on the determination of stress concentration regions that failure or fracture may initiate at these regions. Fracture of gear tooth can be predicted at tooth root area where tension stresses concentrate; hence cracks may initiate and propagate at root area when maximum generated stress at this area exceeds the yield stress. Moreover, pitting may occurs due to stress concentration at contact area.

The other reason of performing stress analysis is to investigate the variation of stress with different fillet radius. The chamfering of the edges of the rack at the contact surface gives the rack a longer fatigue life. It is then proposed to investigate the relationship between the fillet radius and its corresponding stress level at the point of contact to find an optimum fillet radius for the rack.

The highest stress is found at the sharp corners of the rack. The rationale of the simulation is that by chamfering the edges, the highest stress is reduced by distributing the stress around the fillet radius. However with larger fillet radius, the area of contact of the rack with the pinion is reduced. There is a point where the highest stress will start to increase with larger fillet radius. The aim of this simulation is to find out the optimum fillet radius.

### **Contact stress**

Contact stress analysis between two mating gear teeth was considered in different contact positions, representing a pair of mating gears during rotation.

Pitting is a surface fatigue failure resulting from repetitions of high contact stress. The surface fatigue mechanism is not definitively understood. The contact affected zone, in the absence of surface shearing tractions, entertains compressive principal stresses. Pitting commonly appears on operating surfaces of gear teeth, a fundamental cause is excessive loading that raised contact stresses beyond critical levels.

The bending and surface strength of the gear tooth are considered to be one of the main contributors for the failure of the gear in a gear set. Thus, analysis of stresses has become popular as an area of research on gears to minimize or to reduce the failures and for optimal design of gears [24].

### 6.3 Steps of conducting stress analysis

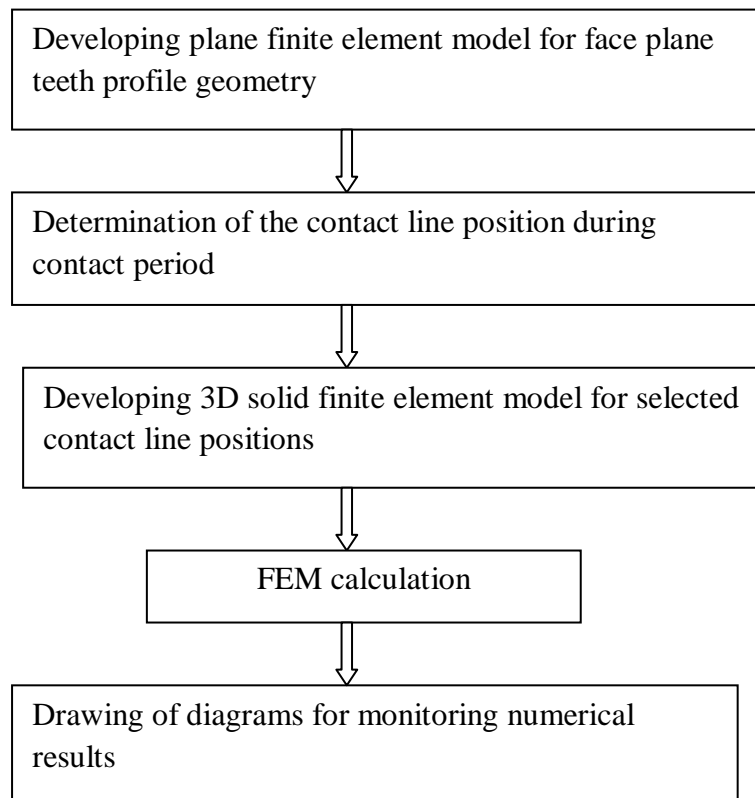

Fig.16 Steps of conducting stress analysis

Gear stress analysis can be performed using analytical methods which required a number of assumptions and simplifications which aim at getting the maximum stress values only but gear analyses are multidisciplinary including calculations related to the tooth stresses and to failures like wear.

## 6.4 Finite Element Analysis

The Basic concept in FEA is that the body or structure may be divided into smaller elements of finite dimensions called “Finite Elements”. The original body or the structure is then considered as an assemblage of these elements connected at a finite number of joints called “Nodes” or “Nodal Points”. Simple functions are chosen to approximate the displacements over each finite element.

Such assumed functions are called “shape functions”. This will represent the displacement within the element in terms of the displacement at the nodes of the element. The Finite Element Method is a mathematical tool for solving ordinary and partial differential equations. Because it is a numerical tool, it has the ability to solve the complex problems that can be represented in differential equations form. The applications of FEM are limitless as regards the solution of practical design problem [25]. For three-dimensional stress analysis solid elements are useful for the solution of problems. These solid elements are broadly grouped under tetrahedral, triangular and hexahedral family elements. The concept of iso-parametric element is based on the transformation of parent element in local or natural coordinate to system to an arbitrary shape in Cartesian coordinate system [26].

### Basic steps in FEA

- Discretization of the domain
- Application of Boundary conditions
- Assembling the system equations
- Solution for system equations
- Post processing the results

- ✚ Discretization of the domain: The task is to divide the continuum under study into a number of subdivisions called element. Based on the continuum it can be divided into line or area or volume elements.
- ✚ Application of Boundary conditions: From the physics of the problem we have to apply the field conditions i.e. loads and constraints, which will help us in solving for the unknowns.

- ✚ Assembling the system equations: This involves the formulation of respective characteristic (Stiffness in case of structural) equation of matrices and assembly.
- ✚ Solution for system equations: Solving for the equations to know the unknowns. This is basically the system of matrices which are nothing but a set of simultaneous equations are solved.
- ✚ Viewing the results: After the completion of the solution we have to review the required results.

### 6.5 Modeling

The available gear design softwares are mathematical in nature for the proper modeling of the involute curve and the tooth profile generated from the curve. Dedicated gear design programs perform the calculations, which are necessary to create the true profile of the gear tooth, but this is a tedious and time-consuming operation.

However, CAD/CAM applications can do this in seconds to generate a correct involute tooth profile quickly and easily due to their graphical nature. They are graphical modeling tools and there are a finite number of calculations they can perform and a finite number of points they plot along the involute curve.

CAD systems approximate shapes such as involute tooth profile by defining points along a curve and then simply connecting those points with a straight lines. The more points you can plot, the smaller the lines are used to draw the curve. While they can plot many of points along the curve, coming close to the involute profile, there is always an error due to the need for the software to approximate using points and lines.

Dedicated gear design programs allow to make a gear that is within the AGMA or ISO quality rating. In fact the standards are already in corporate into many gear design programs. For application where precise tooth profiles are not necessary as in the gear design itself, solid-modeling systems are very useful. Solid modeling is a good downstream tool, good for defining tool paths for lasers and other systems that can draw data from CAD systems. These capabilities and applications make modern CAD/CAM systems such as CATIA

very power full engineering design tool with a great deal to offer for the designer. All of this flexibility is possible by the process called parametric modeling [27,28].

Gear modeling consists of several phases, depends from gear body and kind of its production:

- The first phase of gear modeling is definition and making real involutes gear teeth profile.
- In case of cutting or pressed gear body it is to use Part design CATIA module to make gear body.
- In case of welding way made gear body it is to use Assembly design module to connect all its parts.

A gear modeling is very useful and important, as to make real gear transmission simulation, so for lot of other analysis. Different software tools are in use today for machine design and machine elements modeling, as ACAD, Mechanical Desktop, Pro Engineer and Solid Works, CATIA etc. But it is to see that gear modeling with real profiles is more complicated compared with modeling of all other machine elements. Here will be presented the possibilities of cylindrical gears modeling using CATIA V5R11 software. Depends of production way and form of gear body it is possible to use Part design module or Assembly design module of CATIA soft

### CATIA V5

CATIA V5 (Computer-Aided Three-dimensional Interactive Application) is the product of the highest technological level and represents standard in the scope of designing. Instantaneously, it is the most modern integrated CAD/CAM/CAE software system that can be find on the market for commercial use and scientific-research work. The biggest and well-known world companies and their subcontractors use them.

In the heart of the system is the integrated associational data structure for parameter modeling, which makes possible the fact that the changes on model reflects through all related phases of the product development. In that way, time needed for handmade models remodeling cancels. The system makes possible all geometric objects par metering, including solids, surfaces, wireframe models and constructive elements. To obtain the maximum during the work with CATIA V5 system, optimized certificated hardware configurations are recommended.

CATIA goes far beyond traditional 3D CAD software tools to offer a unique Digital Product Experience, based on the 3D experience platform. Sustainable development is driving companies around the globe to create a constant stream of innovative and inspiring smart products. Engineering, Design, systems architecture and Systems Engineering of these products becomes more demanding. This software is very complex, but some main modules such Part and Assembly design are to use in gear modeling.

CATIA offers a solution to model complex and intelligent products through the systems engineering approach. It covers the requirements definition, the systems architecture, the behavior modeling and the virtual product or embedded software generation. CATIA can be customized via application programming interfaces. CATIA V5 & V6 can be adapted using Visual Basic and C++ programming languages via CAA. [29, 30].

#### Modeling of gear in CATIA V5

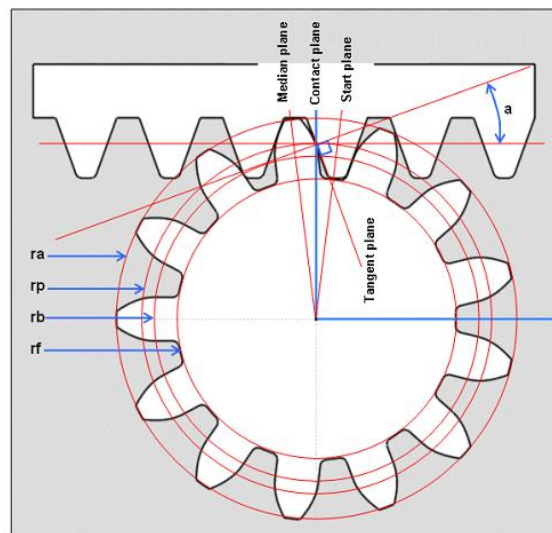

Fig.17 Parameters for pinion modeling

Since the geometry of a spur gear is controlled by a few parameters, we can design a generic gear controlled by the following parameters and their values obtained at the design section.

## General procedure to create model of the gear

- Set up the geometric parameters and formulas
  - The pressure angle,  $\alpha$
  - The modulus,  $m$
  - The number of teeth,  $z$

## Useful parameters and formulas

- ✚  $r_p$  = Radius of the pitch circle
- ✚  $r_a$  = Radius of the outer circle
- ✚  $r_f$  = Radius of the root circle
- ✚  $r_b$  = Radius of the base circle

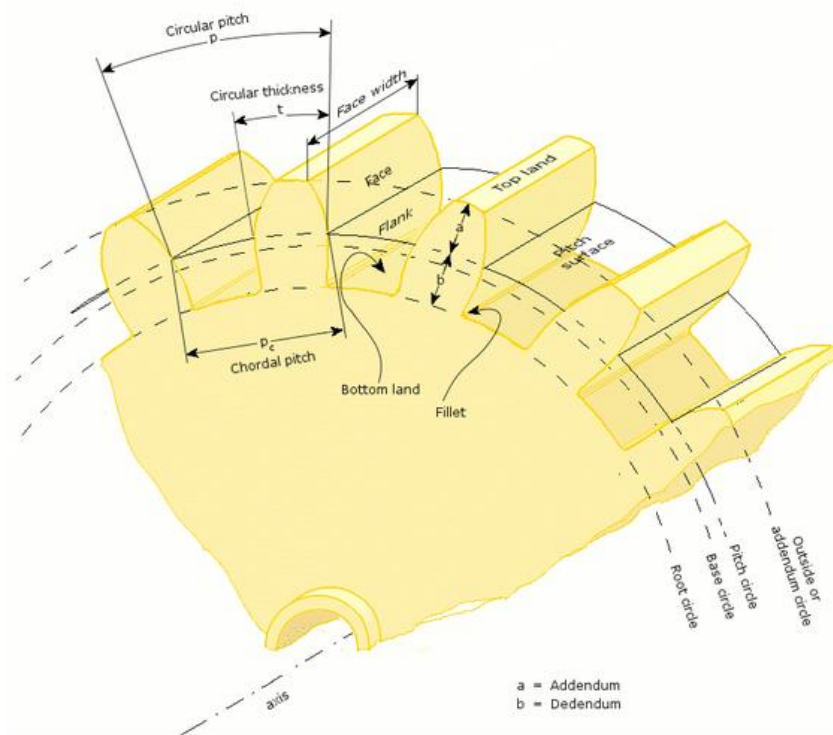

Fig.18 Nomenclature to describe the four circles

- $r_p = m * Z / 2$
- $r_a = r_p + h_a$
- $r_f = r_p - h_f$
- $r_b = r_p * \cos(a)$

Where  $h_f$  is Dedendum = depth of a tooth below the pitch circle

$$h_f = 1.25 * m$$

$h_a$  is Addendum = height of a tooth above the pitch circle

$$h_a = m$$

- Module,  $m$  this indicates the tooth size and is the number of mm of pitch circle diameter ( $D_p$ ) per tooth.
- Pressure angle,  $a$ , is the angle between the line joining the centers of the two gears and the common tangent to the base circles.

*Table 6 Parameters for gear modeling*

Parameters	Values
Number of teeth	18
Module [mm]	2
Pressure angle ( $^{\circ}$ )	20
Addendum [mm]	2
Dedendum [mm]	2.5
Radius of the pitch circle [mm]	18
Radius of the outer circle [mm]	16.914
Radius of the root circle [mm]	15.5
Radius of the base circle [mm]	20

## Parameters

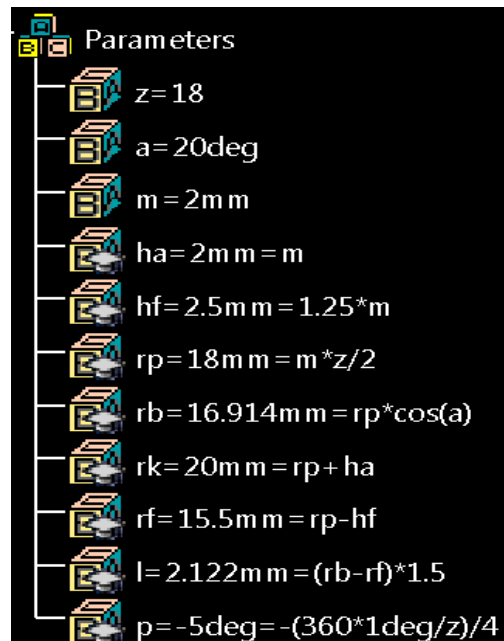

➤ Create points and splines for involute gear teeth by using the following two equations

- $x = rb * (\sin(t * \text{PI} * 1\text{rad})) - rb * t * \text{PI} * \cos(t * \text{PI} * 1\text{rad})$
- $y = (rb * \cos(t * \text{PI} * 1\text{rad})) + ((rb * t * \text{PI}) * \sin(t * \text{PI} * 1\text{rad}))$

Where:-

1rad: The trigonometric functions expect angles, not numbers, so we must use angular constants

PI: stands for the  $\pi$  number.

- Then draw base, root, pitch and outer circle by using parameters set above and results which are summarized in the above table.
- Create the tooth solid feature by feeding its thickness dimension, face width, obtained from design analysis.
- Complete the feature of the pinion with cut and extrusion.
- Create hole for shaft

After feeding these parameters and equations on the Catia program the following three dimensional model of the gear is obtained.

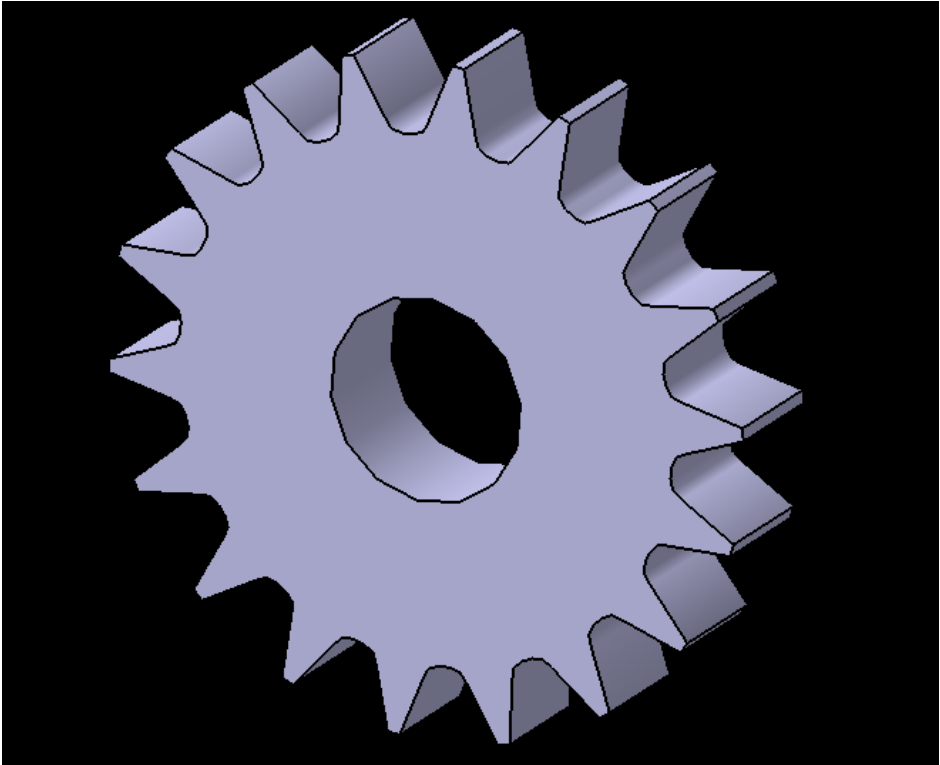
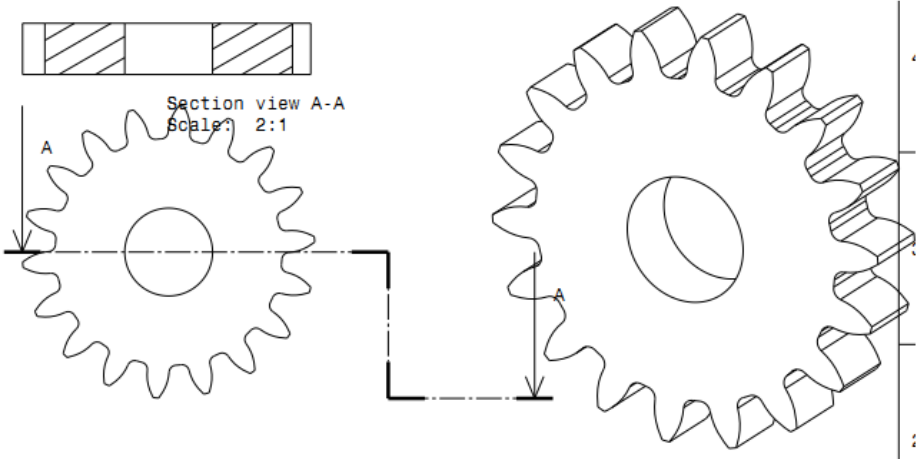

Fig.19 3D model of pinion using Catia

Isometric drawing and two dimensional view of the gear



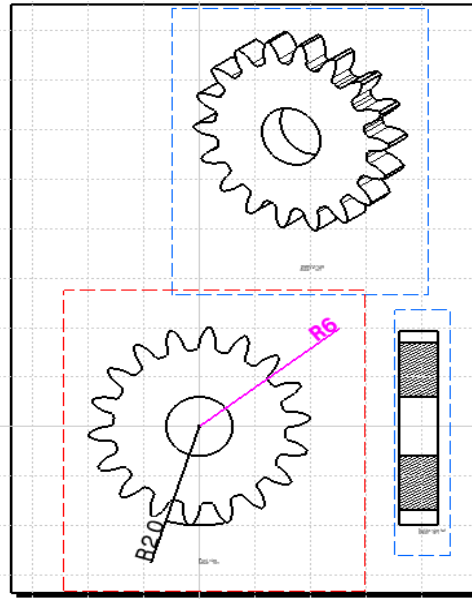

Fig.20 Two dimensional view of gear

After modeling finite element analysis using CAD software is performed to get different results like deformation, displacement and different stress results.

**Steps in performing stress analysis**

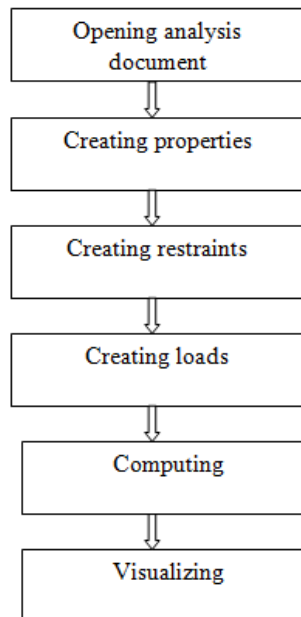

Fig.21 Steps in performing stress analysis using Catia

To analyze the stress there are different inputs before computing the results:

- ✓ Material: before computation select the material from the material library icon and the software sets material properties for the selected type of material.
- ✓ Restraints: Central shaft location is arrested in all DOF. So select clamp for these part.
- ✓ Load: there is tangential load along the x-axis and its value is already obtained on the previous design part. Tangential load,  $W_t = 96.46\text{N}$  (Previously obtained value).

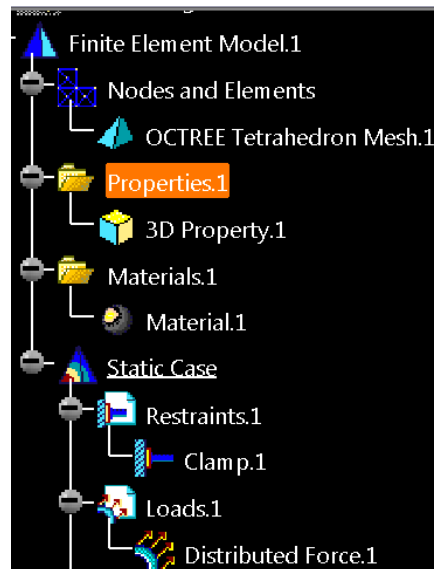

Fig.22 Inputs for the analysis of stress

## 6.6 Contour plot of stress analysis

After setting all parameters and inputs the computation is done to found the following results:

### ➤ Deformation

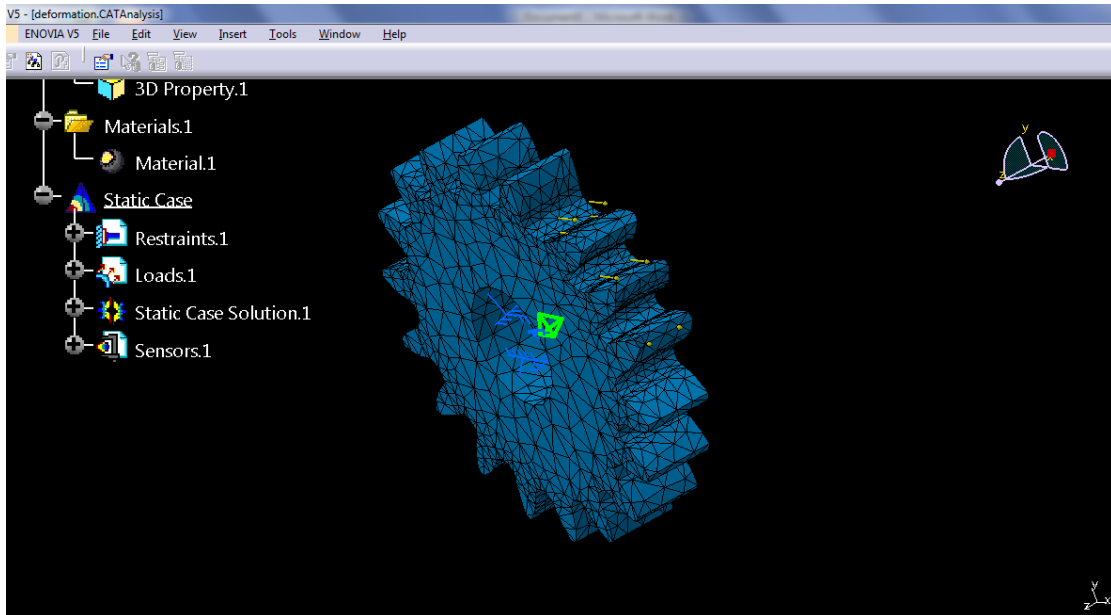

Fig.23 Catia result of Deformation

### ➤ Von misses stress

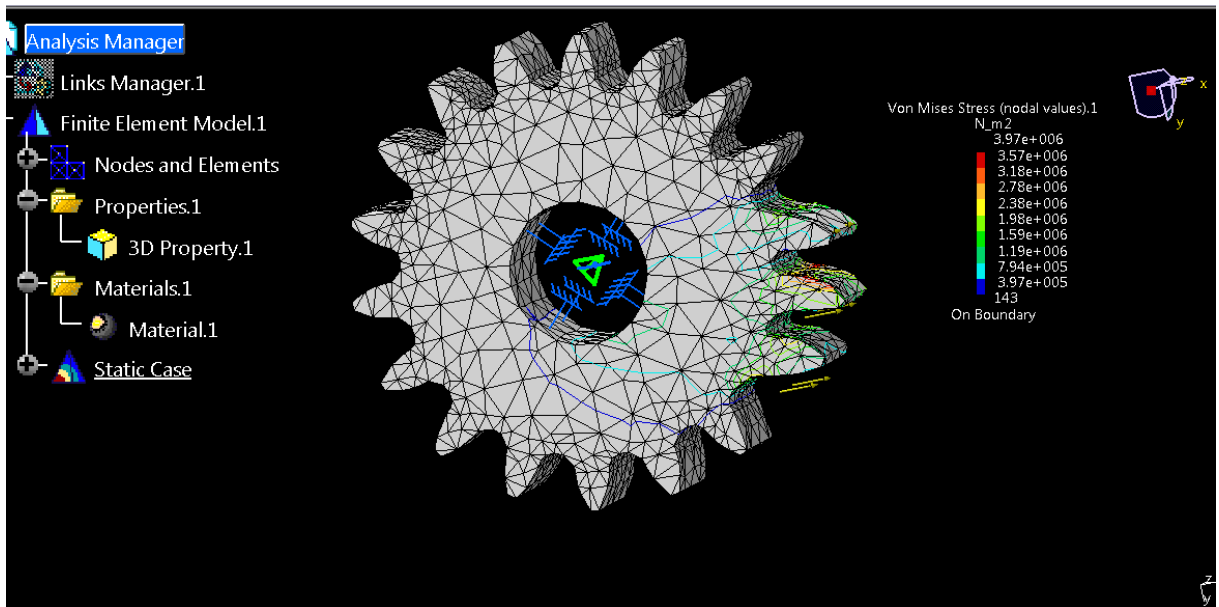

Fig.24 Contour plot of Von misses stress

### Discussion

Von misses stress: The Von Misses criterion is a formula for combining these 3 stresses into an equivalent stress, which is then compared to the yield stress of the material. The yield stress is a known property of the material, and is usually considered to be the failure stress. In an elastic body that is subject to a system of loads in 3 dimensions, a complex three dimensional system of stresses is developed. That is, at any point within the body there are stresses acting in different directions, and the direction and magnitude of stresses changes from point to point. The Von Misses criterion is used for calculating whether the stress combination at a given point will cause failure.

The design will fail, if maximum value of Von Misses stress induced in the material is more than strength of the material. It works well for most of the cases, especially when material is ductile in nature.

As we can see from Catia result maximum value for von misses stress is equal to  $3.97e+006$  and strength of material is 85Mpa so according to the above comparison the gear is safe for failure.

#### ➤ Displacement

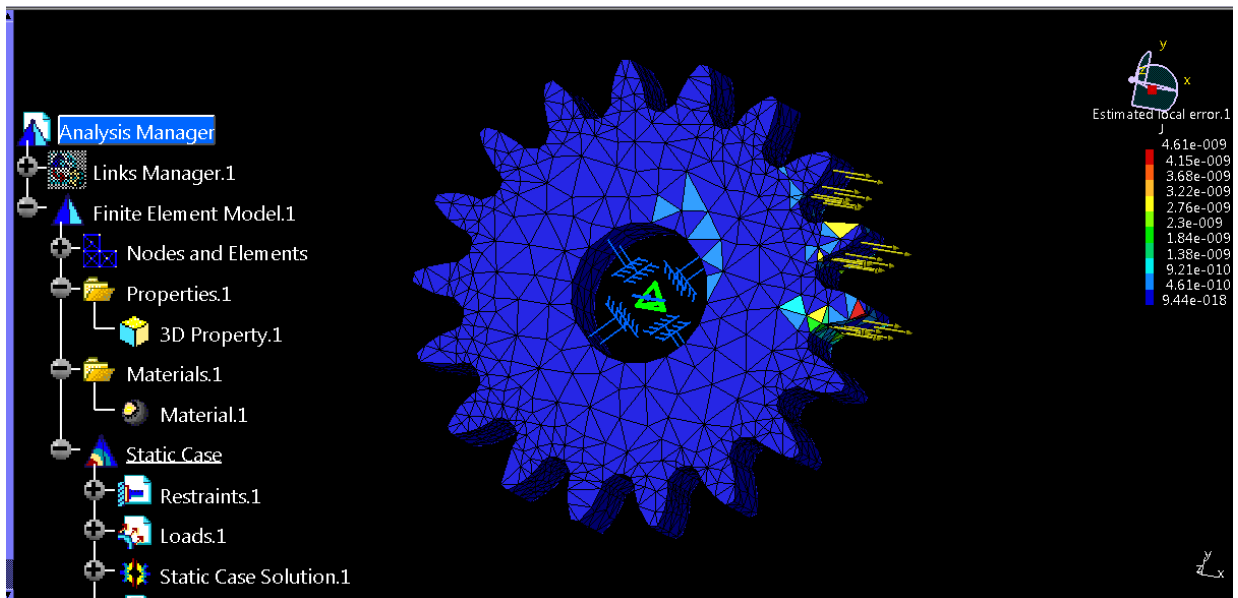

Fig.25 Contour plot of Displacement

➤ **Principal stress**

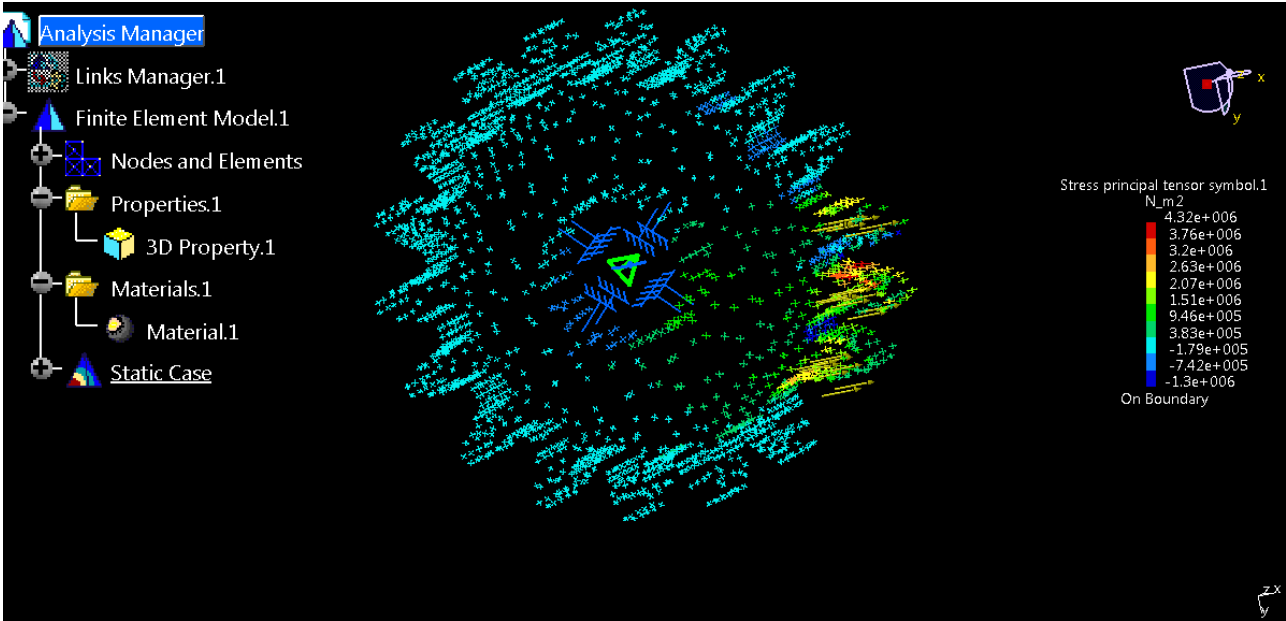

Fig.26 Principal Stress

## 7. Conclusion and Recommendation

There are different types of oil press machine to squeeze oil from different oil seeds for different purpose. In this thesis work, electrical motor driven mechanical oil press with rack and pinion system is designed and optimized. Design of oil press machine includes selection of appropriate motor with its specification, design of mechanical parts, controlling mechanism and stress analysis.

In design of mechanical oil press part gear system of the machine is designed to obtain the basic parameters and to check its safety against bending and pitting. In addition to this shaft design, bearing selection, and ram press design have been done. In shaft design, diameter of the shaft is determined and appropriate material was selected. In bearing design the basic dimensions of bearing that fits the shaft diameter was done. In ram design, material suitable for the operation was selected and also its dimensions are obtained.

In controlling system of the machine proper type of an electric motor with appropriate speed and power was selected. Since the motor is bidirectional, to move the ram up and down, the controlling mechanism of the motor was done. To achieve motor forward or clockwise and reverse or anti-clock wise microcontroller that serves with the motor was selected and assembly language is written to communicate with oil press machine.

In order to make an oil press safe stress analysis of the gear system was performed and it is used to determine stress concentration region and find its maximum stress and compare its value with the value obtained in the design analysis. Stress concentration areas and its maximum value sets with contour plot obtained using Catia stress analysis.

Finally, as a recommendation it is better to study physical and chemical properties of oil seed deeply to know which oil seed is suitable for this oil press machine and to know quantity of oil obtained.

**Parts**

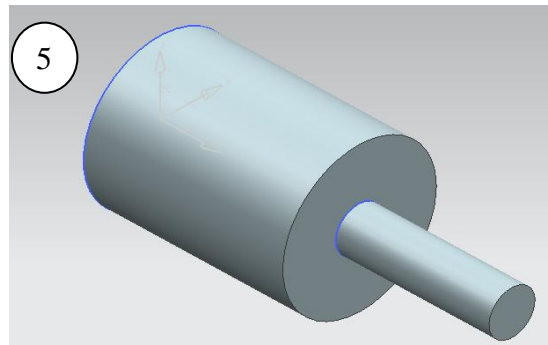
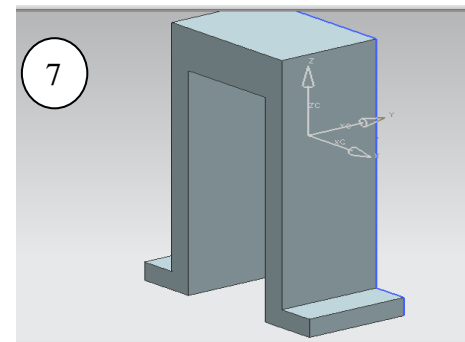
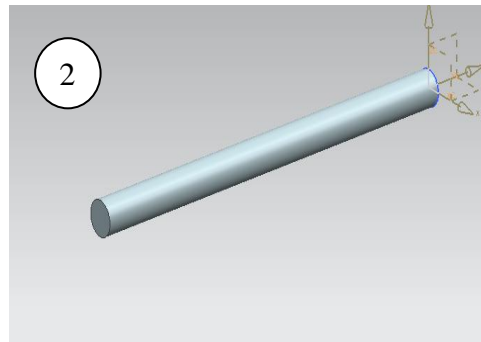
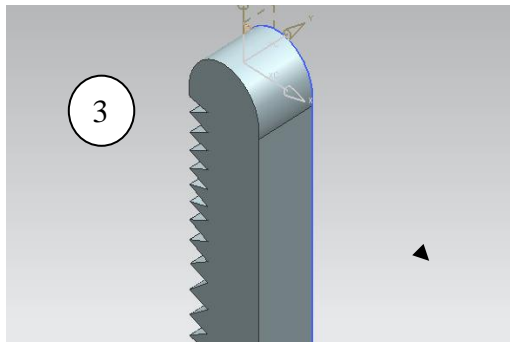
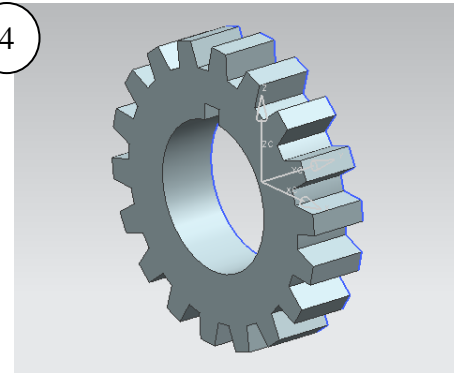
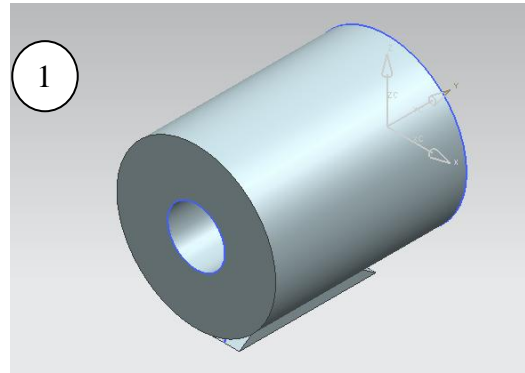
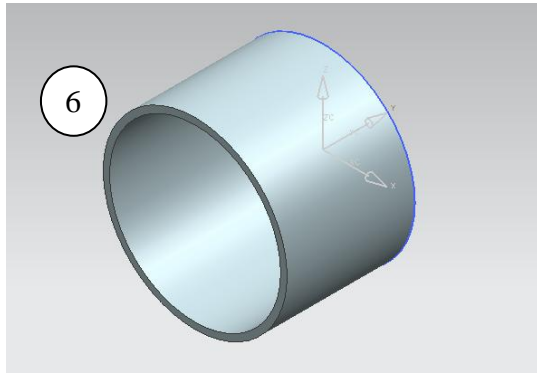

Assembly Drawing

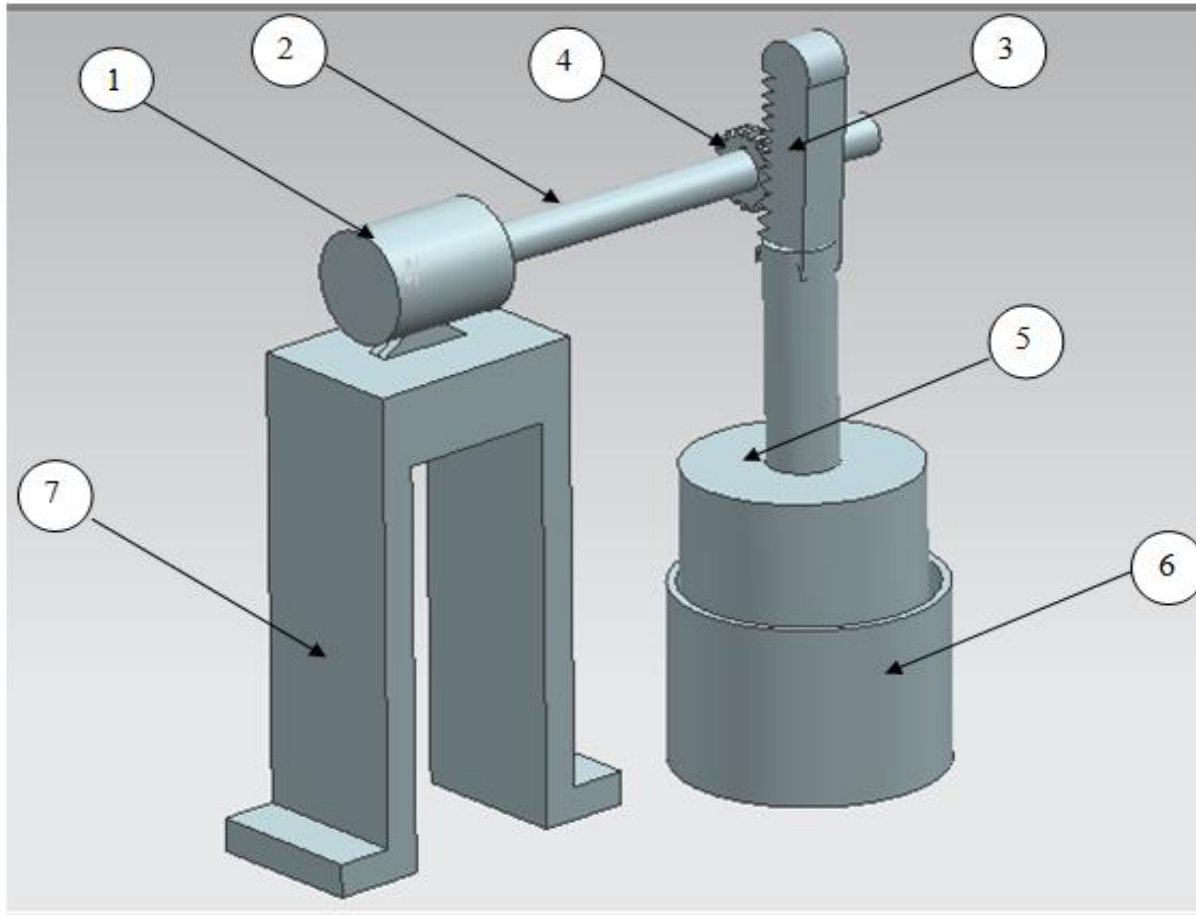

Fig.27 Electric Motor driven Mechanical oil press

Part name	
1	Motor
2	Shaft
3	Rack
4	pinion
5	press
6	cylinder
7	supporter

## 8. Reference

- [1] Weiss E.A., 1999, Oilseed Crops, Iowa State University Press, 2<sup>nd</sup> edition, Ames, Iowa, USA.
- [2] Widmann, B.1988. Extraction and cleaning of rape oil seed studies on small plant, Freising Weihenstephan, West Germany.
- [3] Jacobsen, L.A. and Backer, 1986; Recovery of sunflower oil with a small Screw expeller, Energy in agriculture, Elsevier Science publishers B.V., Amsterdam. Netherlands.
- [4] Riley, K.W. & Belayneh, H. 1989. Niger – In: Oil crops of the world, McGraw-Hill, New York. pp. 394-403.
- [5] Herz, Jonathan, Using and Maintaining the Ram Press. Enterprise Works Worldwide. Washington DC. , 1997.
- [6] Boyd, John. 1995. Tools for Agriculture, 3rd edition. VITA Publications
- [7] Judge, Emma. Small-Scale Food Processing, 2nd Ed. Intermediate Technology Publications, 2000.
- [8] Eric.L Lynn Schlueter (SIDO); Hugh Allen (CARE); Jonathon Otto (AT1 Consultant); Carl Bielenberg, Jeanne Downing, and Susan Swift (ATI). Final revision accepted October 29, 1992.
- [9] Eric Hyman Production of Edible Oils For the Masses and By the Masses: The Impact of the Ram Press in Tanzania, , Appropriate Technology International, Washington DC.
- [10]Jaswant Singh, P.C. Bargale, Indian Institute of Sugarcane Research (ICAR), Dilsukha, Lucknow 226 002, UP, India.
- [11] Isobe, S., Zuber, F., Uemura, K., Noguchi, A., 1992. A new twin-screw press design for oil Extraction of dehulled sunflower seed. J. Am. Oil Chem. Soc. 69, 884–889.
- [12] Rig al, L., 1996. Twin-screw Extrusion Technology and Fractionation of Vegetable Matter. ENSC, Toulouse, France.
- [13] Khan, L. M., & Hannah, M. A. (1984). Expression of soybean oil. Transactions of the ASAE, 27(1), 190–194.

- [14] J.C. Igbeka, T.J. Afolabi Department of Chemical Engineering, Ladoke Akintola University of Technology, Nigeria.
- [15] R.Supengcum, V.Phupha,T.Natatan, Faculty of engineering in Industrial Engineering Program, Rajamangnla University of Technology, the 2<sup>nd</sup> international conference, 2010.
- [16] J.J. Mpagalile a, M.A. Hannab, R. Weber b Department of Food Science and Technology, Sokoine University of Agriculture, Morogoro, Tanzania
- [17] Seed oil extraction using a solar powered screw press, J.J. Mpagalile, M.A. Hanna, R. Weber, Industrial Agricultural Products Center, University of Nebraska, 209 L.W. Chase Hall, Lincoln, NE 68583-0730, USA
- [18] A. D. Dhale<sup>1</sup>, J. P. Modak, Formulation of experimental data based model for oil press using human powered flywheel motor as energy source, Mechanical Engineering Department, Priyadarshini College of Engineering, CRPF Camp, Nagpur, M.S. 440019, India)
- [19] Boresi A.P. and Schmidt R.J. (2003), ‘Advanced Mechanics of Materials’, Sixth edition, John Wiley & Sons (ASIA) Pte. Ltd., Singapore, pp. 589-624.
- [20] Shigley, J.E., and Mischke, C.R., Standard Handbook of Machine Design, McGraw-Hill, USA, 1996.
- [21] [www.mwfr.com/book.html](http://www.mwfr.com/book.html)
- [22] Yale patt, 8051 microcontrollers and application, an American professor of electrical and computer engineering at university of Texas, Austin.
- [23] Dr. Y.Narasimha Murthy.Ph.d, Microprocessor and micro controller.
- [24] Wilcox L., and Coleman W., “Application of Finite Element to the Analysis of Gear Tooth Stresses ”, Journal of Engineering for Industry, Vol. 95, No. 4, pp. 1139 -1148, 1973.
- [25] B.Harish Reddy, G.shiva Kumar, ‘Static and dynamic analysis of spur gear’, Gokaraju Rangaraju institute of Engineering and Technology.
- [26]. Krishaamoorthy, C., Finite Element Analysis Theory and programming, Tata McGraw-Hill,

New Delhi, 1994.

[27]. <http://www.geartechnology.com/mag/gt-model.htm>

[28]. <http://www.geartechnology.com/mag/gt-solid.htm>

[29]Dassault Systems, <http://www.3ds.com/home>

[30] CATIA Web-based Learning Solutions Version V5 Release 18 Windows, Dassault Systems, 2007.

[31] [Sustainablenations.org/resources/oilseed.pdf](http://Sustainablenations.org/resources/oilseed.pdf), oil seed processing for small scale producers.

[32] Janet Bachmann, agricultural specialist, Small scale oil seed processing, 2001. [www.pssurvival.com/ps/biodiesel/oil from seeds.pdf](http://www.pssurvival.com/ps/biodiesel/oil%20from%20seeds.pdf)

[33]Sven Bernesson, extraction of rape seed oil and farm operation of Elsbett engine tractor, Swedish university of agricultural science, 1994.

Appendix A: Graph for geometry factor, J

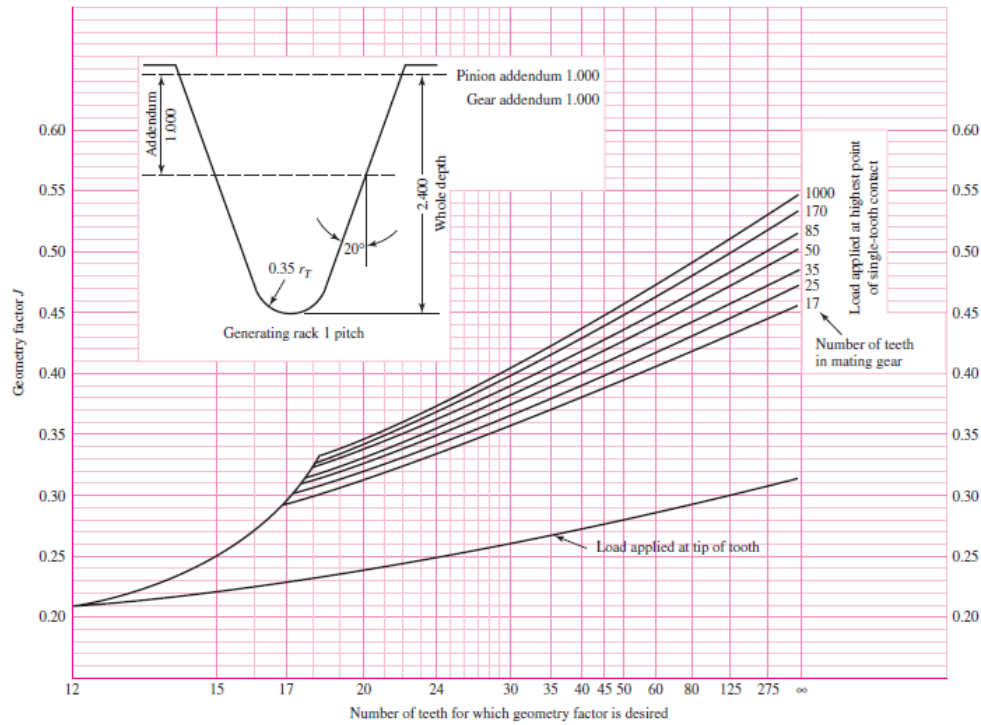

Appendix B: AGMA fatigue strength table, Sc

Material	AGMA class	Comm ercial design ation	Heat Treatment	Minimum Hardness surface	at Core	Sc	
						Psi	Mpa
Steel	A-1 Through A-5	-	Through- Hardened And Tempered	180 BHN	-	85-95 000	470-660
				And less	-		
				240BHN	-	105-115 000	720-790
				300BHN	-	120-135 000	830-930
				360BHN	-	145-160 000	1000-1100
				400BHN	-	155-170 000	1100-1200

Material	AGMA class	Commercial designation	Heat treatment	Minimum Hardness at surface	Core	S <sub>t</sub>	
						Psi	Mpa
Steel	A-1 Through A-5	-	Through-Hardened And Tempered	180 BHN	-	25-33000	75-230
				240BHN	-	31-41000	210-280
				300BHN	-	36-47000	250-320
				360BHN	-	40-52000	280-360
				400BHN	-	42-56000	290-390

Appendix C: AGMA bending strength, S<sub>t</sub>

Pinion tooth No.	No. of racks	Rack length L(mm)	Rack face width F(mm)	Rack grade	Angle per pinion revolution
18	12	150	2.0	4	4 <sup>0</sup>
20	12	315	2.5	4	2 <sup>0</sup>
22	24	330	2.5	4	2 <sup>0</sup>
24	12	180	2.0	4	4 <sup>0</sup>

Appendix D:  
Rack dimension catalog

26	24	390	2.5	3	1 <sup>0</sup>
28	12	210	2.0	4	4 <sup>0</sup>
30	24	450	2.5	3	1 <sup>0</sup>
32	12	240	2.5	4	4 <sup>0</sup>
35	24	520	2.5	3	1 <sup>0</sup>
40	24	600	2.5	3	1 <sup>0</sup>

Appendix E: Load distribution factor  $K_m$  and  $C_m$  for spur and Helical gears. (Helical Gear values are shown in brackets)

CONDITION OF SUPPORT	FACE WIDTH F in (mm)			
	$\leq 2(50)$	6(150)	9(225)	$\geq 16(400)$
Accurate mounting, low bearing clearance, minimum deflection, precision gears	1.3 [1.2]	1.4 [1.3]	1.5 [1.4]	1.8 [1.7]
Less rigid mounting, less accurate gears, contact across full face	1.6 [1.5]	1.7 [1.6]	1.8 [1.7]	2.0 [2.0]
Accuracy and mounting such that less than full face contact exists	$>2.0[ >2.0 ]$			

