



ADDIS ABABA UNIVERSITY  
ADDIS ABABA INSTITUTE OF TECHNOLOGY  
SCHOOL OF ELECTRICAL AND COMPUTER ENGINEERING

# **Mobile Data Offloading using Wi-Fi for the case of Ethio Telecom in Addis Ketema Area**

By  
Wudneh Alebign  
Advisor  
Dr. Yihenew Wondie

A Thesis Submitted to the School of Graduate Studies of Addis Ababa  
University in Partial Fulfillment of the Requirements for the Degree of  
Masters of Science in Communication Engineering

June, 2018  
Addis Ababa, Ethiopia

ADDIS ABABA UNIVERSITY  
ADDIS ABABA INSTITUTE OF TECHNOLOGY  
SCHOOL OF ELECTRICAL AND COMPUTER ENGINEERING  
**Mobile Data Offloading using Wi-Fi for the case of  
Ethio Telecom in Addis Ketema Area**

By: - Wudneh Alebign

**Approved by Board of Examiners**

Chairman, School of Graduate Studies

\_\_\_\_\_  
Signature

**Committee**

Dr. Yihenew\_Wondie

Advisor

\_\_\_\_\_  
Signature

\_\_\_\_\_  
Internal Examiner

\_\_\_\_\_  
Signature

\_\_\_\_\_  
Internal Examiner

\_\_\_\_\_  
Signature

# Declaration

I, the undersigned, declare that this thesis is my original work, has not been presented for a degree in this or any other university, and all sources of materials used for the thesis have been fully acknowledged.

Wudneh Alebign

Name

\_\_\_\_\_  
Signature

**Place:** Addis Ababa

**Date of Submission:** July 11, 2018

This thesis has been submitted for examination with my approval as a university advisor.

Dr. Yihenew Wendie

Advisor

\_\_\_\_\_  
Signature

## **Abstract**

One of the most difficult task for any mobile network operator is to efficiently manage an increasing number of mobile data users especially in a congested urban areas. These high number of data users require higher bandwidth and high speed throughput. To overcome these problems, high capital investments are required which are not economically viable. Mobile network operators are forced to see another alternative to solve the problem by using mobile data offloading technologies. Mobile data offloading is one of the technique to efficiently handle the growing mobile data traffic by offloading cellular data traffic to other complementary networks. This will decrease the burden on mobile network operators and increase the capacity of data network.

Collected data from ethio telecom shows that there is high number of mobile data traffic usage in 3G network that creates network congestion. Currently in Ethiopia ethio telecom solves the problem by upgrading cellular network to 4G/LTE, using smaller cell/sector method and upgrade cellular network by adding base stations/transmitters and enhance software resources. Since the number of peoples in the urban areas like Addis Ababa are increasing dynamically, it is difficult task for ethio telecom to manage rapid growth of mobile data usage using the above techniques only. Hence offloading cellular network to other complementary network provides ethio telecom an advantage to enhance the data network capacity easily.

This thesis also proposes Wi-Fi offloading technique as one of the alternative way to solve mobile network congestion problems in a congested urban areas in Addis Ababa city Addis Ketema area. The thesis also shows how Wi-Fi offloading will improve the capacity of the whole mobile network using Atoll simulation tools and presents options on the technical integration of Wi-Fi and cellular network. And finally the paper shows the challenges and future works of Wi-Fi offloading in Ethiopia. The simulation result shows that after offloading a percentage of 3G data traffic to Wi-Fi network the required grade of service for both voice and data improved.

**Keywords:** Mobile Data Offloading, Wi-Fi, Wi-Fi Offloading

## **Acknowledgement**

First and foremost, I would like to thank Almighty God who provides me strength this far, and supports me all the way to this phase of my life.

I wish to express my gratitude to my university supervisor, Dr. Yihewew Wondie for his invaluable assistance, support and guidance. Additionally I would like to thank AAIT communication department staffs for their assistance and guidance.

I would like to thank ethio telecom staffs especially Fitsum Mergia and Yibeltal who supports and provides me necessary information. Without their assistance this study would not have been successful.

I would like to thank my family and friends who supports me, especially Tadesse Alebign, who encourages and motivates me beyond my expectation.

# Table of Contents

<b>1 Introduction.....</b>	<b>1</b>
1.2 Statement of the problem .....	2
1.3 Objective .....	3
1.3.1 General objective.....	3
1.3.2 Specific objective .....	3
1.4 Literature Review .....	3
1.5 Scope and Limitation.....	4
1.6 Methodology.....	4
1.7 Contribution.....	5
1.8 Thesis Layout.....	5
<b>2.0 Background.....</b>	<b>7</b>
2.1 Cellular network.....	7
2.2 Wi-Fi network .....	9
2.2.1 Describing WLAN Topologies.....	9
2.2.2 Wi-Fi Standards .....	10
2.2.3 Service Set Identifier .....	12
2.2.4 Roaming technology in WLAN .....	12
2.2.5 WLAN Security .....	13
2.3 Mobile data offloading .....	14
2.3.1 3GPP Release 6.....	14
2.3.2 3GPP Release 7 .....	21
2.3.3 3GPP Release 8.....	22
2.3.4 3GPP Release 9.....	25
2.3.5 3GPP Release 10 .....	25
2.3.6 3GPP Release 11 .....	29
2.3.7 3GPP Release 12 .....	30
2.3.8 3GPP Release 13 .....	31
2.3.9 3GPP Release 14 .....	33
<b>3.0 WLAN design.....</b>	<b>34</b>
3.1 Wi-Fi Coverage and capacity.....	34
3.2 Identify application throughput.....	36
3.3 Key performance indicators .....	36

3.4 Estimating number of Client and AP Counts .....	37
4.3.1 Estimate access point throughput .....	37
<b>4.0 Implementation consideration .....</b>	<b>41</b>
4.1 Cellular network monitoring .....	41
4.2 Resource of 3G network.....	41
4.3 3G Resource usage metrics.....	42
4.3.1 Uplink Load .....	42
4.3.2 Downlink Load .....	43
4.3.3 Channel Element resource usage .....	43
4.3.4 OVSF code usage .....	44
<b>5.0 Simulation.....</b>	<b>45</b>
5.1 Simulation Tool .....	45
5.2 Planning and design.....	45
5.2.1 Addis Ketema site Information .....	45
5.2.2 Deployment Steps .....	47
5.2.3 Traffic parameters .....	52
5.2.4 Propagation model .....	54
5.2.5 Deployment target.....	55
5.2.6 Simulation Steps .....	55
<b>6.0 Result.....</b>	<b>57</b>
6.1 3G Network before Wi-Fi offloading .....	57
6.1.1 Study coverage signal level .....	57
6.1.2 Study transmitter coverage .....	58
6.1.3 3G Capacity analysis .....	58
6.1.3.1 3G network capacity Before Wi-Fi offload.....	58
6.1.4 Result Analysis before Wi-Fi offloading.....	60
6.2 UMTS coverage After Wi-Fi offloading.....	61
6.3 UMTS and Wi-Fi network integration.....	62
6.3.1 Users Demand .....	63
6.3.2 Result .....	64
<b>7.0 Conclusion and future works .....</b>	<b>65</b>
<b>Reference.....</b>	<b>67</b>

## List of Figures

Figure 1 Ad hoc mode WLAN connectivity [5] .....	9
Figure 2 Basic Service Set WLAN connectivity [5] .....	10
Figure 3 Extended Services Set WLAN connectivity [5] .....	10
Figure 4 IEEE 802.11b frequency band allocation [5]. .....	11
Figure 5 Scenario 2 3GPP-WLAN interworking architecture [11].....	16
Figure 6 End to end EAP authentication [11].....	17
Figure 7 Authorization and authentication using diameter. [11] .....	18
Figure 8 authentication based on EAP AKA scheme [12] .....	19
Figure 9 3GPP-WLAN interconnection architecture [12]......	20
Figure 10 ANDSF architecture [16].....	22
Figure 11 Non-Roaming Architecture within EPS using S5, S2a, S2b [16] .....	24
Figure 12 multi access PDN connectivity [15] .....	26
Figure 13 IP Flow mobility [15].....	27
Figure 14 WLAN offloading for different data flow using IFOM [18].....	28
Figure 15 non-seamless IP mobility [18].....	28
Figure 16 111053_Addis Ketema site map .....	46
Figure 17 Study level of signal coverage.....	57
Figure 18 Study transmitter coverage .....	58
Figure 19 3G Capacity Result before Offloading.....	59
Figure 20 3G network simulation after Wi-Fi offloading.....	62
Figure 21 Cumulative Cellular and Wi-Fi network status .....	63

## List of Tables

Table 1 coverage vs capacity [33].....	36
Table 2 application requirement [33].....	36
Table 3 Wi-Fi capability [33].....	37
Table 4 Addis Ketema Site information.....	46
Table 5 1 Site parameter for 3G network.....	48
Table 6 Transmitter parameter for 3G network .....	49
Table 7 Cell parameters for 3G network.....	50
Table 8 Wi-Fi site parameter .....	51
Table 9 Wi-Fi Transmitter parameter .....	51
Table 10 3G user server profile .....	52
Table 11 Wi-Fi user server profile.....	52
Table 12 Terminal profile.....	53
Table 13 Environment profile .....	53
Table 14 User profile for 3G .....	54
Table 15 User profile for 3G .....	54
Table 16 deployment target .....	55
Table 17 user distribution per service.....	56
Table 18 3G network capacity analysis.....	59

## List of abbreviations

1G	First Generation Mobile Networks
2G	Second Generation Mobile Networks
3G	Third Generation Mobile Networks
3GPP	Third Generation Partnership Project
4G	Fourth Generation Mobile Networks
AAA	Authentication, Authorization and Accounting
ANDSF	Access Network Discovery and Selection Function
AP	Access Point
BSS	Basic Service Set
CAGR	Compound Annual Growth Rate
CAPEX	Capital Expense
CDMA	Code Division Multiple Access
DL	Downlink
DSMIPv6	Dual-stack Mobile IPv6
DSSS	Direct-Sequence Spread Spectrum
EAP-AKA	Extensible Authentication Protocol-Authentication and Key Agreement
EDGE	Enhance Data rates for GSM Evolution
eNB	evolved NodeB
EPC	Evolved Packet Core
EPS	Evolved Packet System
ESS	Extended Service Set
FACoA	Foreign Agent Care of Address
FAST	Flexible Authentication via Secure Tunneling
FDD	Frequency Division Duplex
FQDN	Fully Qualified Domain Name
GPRS	General Packet Radio Service
GSM	Global System for Mobile communications

GTP	GPRS Tunneling Protocol
HSDPA	High Speed Downlink Packet Access
HSPA	High Speed Packet Access
HSS	Home Subscriber Server
HSUPA	High-speed Uplink Packet Access
IBSS	Independent Basic Service Set
IEEE	Institute of Electrical and Electronics Engineers
IFOM	IP Flow Mobility
IKEv2	Internet Key Exchange version 2
IMS	Internet multimedia server
IP	Internet Protocol
ISMP	Inter-System Mobility Policy
ISRP	Inter-System Routing Policy
I-WLAN	Interworking-WLAN
LAN	Local Area Network
LEAP	Lightweight Extensible Authentication Protocol
LTE	Long Term Evolution
MAC	Media Access Control
MAPCON	Multiple Access PDN Connectivity
MD5	Message Digest 5
MIMO	Multiple-Input and Multiple-Output
MIPv4	Mobile IPv4
OVSF	Orthogonal Variable Spreading Factor
PCC	Policy and Charging Control
PDA	Personal Digital Assistant
PDN	Packet Data Network
PDN GW	GW Packet Data Network Gateway
PEAP	Protected Extensible Authentication Protocol

PLMN	Public Land Mobile Network
PMIP	Proxy Mobile IP
PMIPv6	Proxy Mobile IPv6
QoE	Quality of Experience
QoS	Quality of Service
RAN	Radio Access Network
RFC	Request for Comments
RNC	Radio Network Controller
RSSI	Received Signal Strength Indicator
RTWP	Received Total Wideband Power
SIM	Subscriber Identity Module
SINR	Signal to Interference-plus-Noise Ratio
SSID	Service Set Identifier
TCP	Transmission Control Protocol
TLS	Transport Layer Security
TTLS	Tunneled Transport Layer Security
UDP	User Datagram Protocol
UE	User Equipment
UL	Uplink
UMTS	Universal Mobile Telecommunications System
VoIP	Voice over IP
VPLMN	Visited Public Land Mobile Network
VPN	Virtual Private Network
WCDMA	Wideband Code Division Multiple Access
Wi-Fi	Wireless Fidelity
WiMAX	Worldwide Interoperability for Microwave Access
WLAN	Wireless Local Area Network

# 1 Introduction

Our world is connected through globalization and becoming one village through Internet. Internet plays a crucial role in the current dynamically growing world by connecting peoples and providing instant access to global information. The number of Internet users using mobile data network is also increasing from time to time in the world. The introduction of smart phones and tablets in the market and the people's habit in the use of Internet for social networking, web surfing, instant messaging, video communications are increasing from time to time and it will have impact on the current mobile networks. Mobile network operators are expected to ensure that their networks are able to handle an increase number of mobile data network usage.

From Cisco visual networking index [1], global mobile data traffic will increase nearly seven fold between 2016 and 2021. Mobile data traffic will grow at a compound annual growth rate (CAGR) of 47 % from 2016 to 2021, reaching 49 Exabyte per month by 2019. Further the study shows that by 2016, 63 percent of all traffic from mobile-connected devices (almost 84 Exabyte) will be offloaded to the fixed network by means of Wi-Fi devices and femtocells each month. Of all IP traffic (fixed and mobile) in 2021, 50% will be Wi-Fi, 30% will be wired, and 20% will be mobile. In Ethiopia also the number of users who have access to mobile Internet especially in the urban areas are increasing from time to time. In May 2017 the GlobaStats Stat Couter studies shows that, from total Ethiopia Internet connection 80.08% of Internet connection come from mobile network, whereas 17.74% come from desktop usage and the rest 1.18% Internet usage come from tablet users [2]. The number shows that there are high number of mobile data usage in Ethiopia compared with desktop.

Additionally in Ethiopia ethio telecom provides EVDO, 3G and 4G data VPN service for banking, public and private sectors to connect their branches using mobile network. All the increase in mobile data usage consumes the mobile data network and obviously will create network congestions [43].

Hence mobile network operators have to plan forward and expected to provide good performance and higher capacity data service to their customers in parallel before network congestion is created

There are a number of ways to address the network congestions problems, these are by creating smaller cells, using heterogeneous network and by using mobile data offloading. Mobile data

offloading is a technique that offloads data connection from cellular network to another complementary network. Currently mobile data offloading becomes interesting and cost effective technology compared with the other methods to solve mobile network congestions by integrating both 3GPP standard (cellular) network with non-3GPP network [27].

The thesis also focuses and describes how mobile data offloading using Wi-Fi technology will reduce network congestion problems and increases the overall capacity of the wireless network for the case of ethio telecom in Ethiopia, Addis Ababa, Addis Ketema area. As we know Wi-Fi uses unlicensed band spectrum that is working in the band of 2.5 GHz and 5GHz Frequency. Wi-Fi has a capacity that can provide a data rate service up to 300Mbps based on IEEE 802.11n standard and even up to 1Gbps speed with a new IEEE 802.11ac standard with low price scheme compared with other wireless technologies [44]. This will enable the mobile network operators to deliver broadband Internet service to their customers with satisfied data rate, with a good indoor coverage and increase its income.

## **1.2 Statement of the problem**

Mobile network congestion is one of the most critical issue for mobile network operators. Data's from ethio telecom shows that there is 3G network congestion problems mainly comes from data connection. The problem also imposes a burden on ethio telecom to provide reliable service to its customers. There are a number of factors that enables network congestion to occur on mobile networks. But mainly network congestion occurs due to a rising number of users that uses mobile data services. The increase usage of high speed Internet, network intensive mobile applications, gaming and videos are the main source of mobile data network congestions.

This problem will have negative effect on the satisfaction of subscribers by decreasing the traffic intensity and performance of mobile service. It will also create a burden for ethio telecom to handle all mobile data services using cellular network only.

Currently in Ethiopia ethio telecom tries to solve the problem by upgrading cellular network from 3G to 4G network, using additional transmitters, using smaller cells/sectoring mechanism and enhancing software resources. But this option is not a cost-effective way to solve the mobile data congestion problems in most congested urban areas. Therefore, this paper proposes Wi-Fi

technology as an alternative way to solve this problem by offloading mobile data traffic in to Wi-Fi network.

The main purpose of the paper is to solve the current network congestion problem in most congested urban areas in Addis Ababa like stadium, market places and in the densely populated areas in a cost-effective way using Wi-Fi network compared with other methods.

Moreover, this paper shows how mobile data offloading using Wi-Fi increases the data coverage of indoor areas and traffic intensity of the cellular network. In another way, it will increase the capacity of the cellular network. Hence it will increase the satisfaction of its customers, increase the income of ethio telecom. Wi-Fi network integration with cellular networks. Finally the paper discusses on the challenges and futures works on the deployment of Wi-Fi offloading in Ethiopia.

## **1.3 Objective**

### **1.3.1 General objective**

The main objective of the project is to solve the mobile network congestion problems for the case of ethio telecom in Addis Ababa, Ethiopia particularly in congested areas like stadium, market places, and densely populated areas by offloading mobile data traffic in to Wi-Fi network.

### **1.3.2 Specific objective**

Specifically this paper addresses the following three points.

1. Reduce mobile data traffic to complementary Wi-Fi network using atoll simulation tool.
2. Increase the capacity of mobile network in the integration with Wi-Fi network.
3. Increase the satisfaction of the mobile network customer by increasing data rate service.

## **1.4 Literature Review**

There are different literatures studies about mobile data offloading advantage, best technical approaches and Wi-Fi offloading feasibility status and maturity status.

Rebecchi, et al. presents advantage of mobile data offloading and different approach on technical implementation [45]. They shows that the rapid increase in video traffic creates burden on cellular network and discussed that shifting the network load to another wireless technology improves the

overall throughput, network coverage and increase network availability. Additionally they classify offloading techniques using fixed Wi-Fi access points (AP) and using Terminal-to-terminal approaches. Where in fixed access point mode the users' data traffic will be offloaded to fixed Wi-Fi AP. while in Terminal-to-Terminal mode users use another subscriber mobile phones as intermediate or bridge device. I.e. users are not expected to directly connect to Wi-Fi AP.

Beneyam, et al. presents mobile data offloading business model for the case of Africa market [46]. They covers different approaches of mobile data offloading techniques including current vendor solutions that are available in the market. Additionally they showed standardization on the integration of cellular and Wi-Fi network become mature and analyze in depth from political, economic, social and technical approach and proposes best business model approach for the case of Africa.

Rajavelsamy, et al. reviews the evolution of 3GPP integration with WLAN network [47]. Based on their study starting from 3GPP release 6 up to release 13, the integration between cellular and WLAN shifted from loose integration to more tight and seamless integration. Additionally they forecasted that leveraging WLAN cost-effectiveness and its unlicensed radio access technology it will maximize the revenue of mobile network operators.

Aijaz, et al. analyzes practical aspects of mobile data offloading to Wi-Fi network [48]. They discussed that although the integration of cellular and WLAN network become mature through time, still there are some challenges that needs to be addressed. Hence they proposes different recommendation for different levels of challenges.

## **1.5 Scope and Limitation**

The scope of the thesis is limited to show how Wi-Fi offloading reduce mobile network congestion problems by integrating cellular network and Wi-Fi network together from technical aspect only. The thesis work simulation focuses in Ethiopia, Addis Ababa city, Addis Ketema area only. The paper doesn't cover from legal, social and business angles.

## **1.6 Methodology**

The thesis work started by reading about mobile network congestions, the reason behind mobile network congestions, and isolate different options to solve the problem. After communicating ethio

telecom, it is clear that the problem is visible in Addis Ababa, Ethiopia area especially in congested places. And then study about basic mobile network technologies and do literature reviews related to cellular network, Wi-Fi network and about mobile data offloading techniques. Additionally in order to make the study visualize Atoll simulator is selected which is one of popular planning tool which can simulate both cellular and Wi-Fi network together. The next step was gathering necessary data like identifying places where areas that are most congested, gather cellular design parameters and information of site, transmitter and cell parameters, avail Atoll simulator and Addis Ababa digital maps. It takes some time to gather all necessary data's and to familiarize with Atoll simulation tools. Since in Addis Ababa area most of users are using 3G network, we have covered in simulation part 3G and Wi-Fi network technology only. Then using gathered 3G network design parameters from ethio telecom, the first simulation is started on selected congested sites. And see the results of simulation, identify the reasons behind network congestions. The next simulation is done by offloading some percentage of cellular network in to Wi-Fi network and see the result and identify the changes. Then compare the simulation result before and after offloading from coverage, capacity and performance level. Finally based on the outcomes of simulation result the paper will do recommendation, conclusion and future works to do.

## **1.7 Contribution**

Although there are different literature reviews on the advantage of mobile data offloading and also known that some telecom companies already implemented as alternative way to manage mobile data traffic, ethio telecom still not leverage the advantage. Hence this thesis work is mainly to recommend ethio telecom to see mobile data offloading using Wi-Fi as an alternative way to solve network congestion problems in urban areas.

## **1.8 Thesis Layout**

The thesis work is organized in order to give a clear understanding regarding the subject matter. Chapter one contains the introduction, statement of the problems, objective of the thesis, literature review, scope of the thesis, methodologies, contribution and thesis layout. Chapter two presents basic study behind the thesis works that includes cellular network, Wi-Fi network and about mobile data offloading. Chapter three discusses about Wi-Fi design considerations in very congested places and calculates the required number of access points that are needed to cover a given area.

Chapter four presents considerations for 3G network before implementation. Chapter five contains the simulation part and shows gathered data from ethio telecom and also contains planning and design of 3G and Wi-Fi network. Chapter six present the result based on simulation output. Mainly the result contains 3G network before offloading, after offloading and in the integration of 3G and Wi-Fi network. Finally conclusion, recommendation and future works on the thesis works.

## 2.0 Background

### 2.1 Cellular network

Mobile network is evolved drastically for the last four decades. Starting from first generation 1G network to fourth generation 4G LTE networks, the mobile network is increased in capacity and service types. The growth in information technology and internet has direct impact on the advancement of mobile network. Next we will revise the mobile generations from different perspectives.

#### **First Generation (1G) wireless mobile network**

The 1G is known as the first generation mobile telecommunication was introduced in 1980s and mainly uses to give analog based voice service to customers [38]. Technically the 1G mobile network uses frequency modulation technique with 150 MHz frequency bandwidth and had 2.4kbps speeds [39]. There were different standards of 1G mobile network like Advance Mobile Phone Service (AMPS), Nordic Mobile Telephone (NMT), and Total Access Communication System (TACS). 1G mobile network had some drawbacks regarding security, voice quality and use of large cell phones.

#### **Second Generation (2G) wireless mobile network**

As peoples need grow to use better voice quality over wireless network and additional application requirements, the mobile technology evolved to 2G mobile network. Basically the 2G network is target to address the drawback of 1G network and introduce additionally technologies like text and image messaging. 2G has higher data rate speed and have better voice quality compared with 1G mobile network. GSM (Global system for mobile communication) is one of the most popular technology which is implemented widely in the world. GSM operates on 900 MHz and 1800 MHz frequency band and uses TDMA (Time division multiple access) technique for transmitting and receiving. The GSM network mainly provides voice service and have drawbacks on providing data service. And because of that 2G network is evolved to 2.5G (second and half generation wireless mobile network) to support data service. The 2.5G mobile network uses packet-switching technology for data communication and works on top of 2G network and provides data rate serves up to 144kbps [40]. The three popular 2.5G technologies are GPRS (General Packet Radio

Service), (HSCSD) High-Speed Circuit-Switched Data and Enhanced Data Rates for GSM Evolution (EDGE). 2.5G mobile network is transition period for 3G network which provides more data rate service to customers.

### **Third Generation (3G) wireless mobile network**

3G network is the third generation wireless mobile telecommunication technology introduced in 2000s which provides data rate service more than 144kbps speed. CDMA2000 and UMTS (Universal Mobile Telecommunications Systems) are most popular standards of 3G network. 3G network introduces voice call and mobile TVs and high speed Internet services. 3G network architecture constitutes User Equipment (UE), Radio access network subsystem and Core network. HSPA and HSPA+ provides additional capacity over previous 3G technology. HSPA provides 14.4 Mbps downlink and 5.76 Mbps uplink while Release 11 HSPA+ provides 336Mbps and 69Mbps respectively [41]. Both HSPA and HSPA+ technologies were the transition to 4G LTE network which provides additional data rate speed.

### **Fourth Generation (4G) LTE wireless mobile network**

As bandwidth intensive Internet applications, videos and gaming usage increase 3G network evolved to 4G LTE network. 4G LTE is fourth generation cellular network based on long term evolution technology. All connections between 4G LTE interfaces are all IP based technology which provides seamless mobility to users. 4G LTE network is capable of providing more than 100Mbps bandwidth to users which utilizes MIMO and OFDM technology to provide high data rate service. 4G LTE comprises The User Equipment (UE), The Evolved UMTS Terrestrial Radio Access Network (E-UTRAN) and The Evolved Packet Core (EPC). Compared from previous 2G and 3G technology 4G LTE technology provides higher capacity, performance, more security and low latency communication.

### **Fifth Generation (5G) wireless mobile network**

Still it is expected that network bandwidth intensive Internet applications will continue and 5G network is in the way parallelly to satisfy peoples need. 5G network is successor of 4G LTE expected to provide more than 1Gbps speed with efficient bandwidth utilization. 5G standards are still in the development stage and it is expected to be implemented in 2020.

## 2.2 Wi-Fi network

Wi-Fi is an acronym for Wireless Fidelity and is most commonly used to describe a wireless local area network based on the IEEE 802.11 series of standards, which is a set of wireless technical specifications issued by the Institute of Electrical and Electronic Engineers (IEEE) [4].

Wi-Fi uses radio waves technology to transmit and receive data between client devices and access point or between client devices. And works mainly in the 2.4 GHz and 5 GHz frequency band. Wi-Fi becomes well known technology as an alternative to wired connections, in connecting Laptops, Tablets, printers, scanners and different Wi-Fi supported devices. Wi-Fi technologies provide wireless connectivity with in a building, campus and city wide environments.

### 2.2.1 Describing WLAN Topologies

Mainly there are two types of WLAN topology these are ad hoc mode and infrastructure mode. Infrastructure mode consists of basic service set and extended service set [5].

- **Ad hoc mode:** in this mode direct peer to peer connection established between two WLAN enabled devices without intermediate



*Figure 1 Ad hoc mode WLAN connectivity [5]*

- **Infrastructure mode:** In this mode WLAN enabled devices connected through additional 3<sup>rd</sup> party wireless access point. There are two types of infrastructure mode
  - **Basic Service Set:** in this mode a single wireless access point devices interconnect WLAN enable devices.

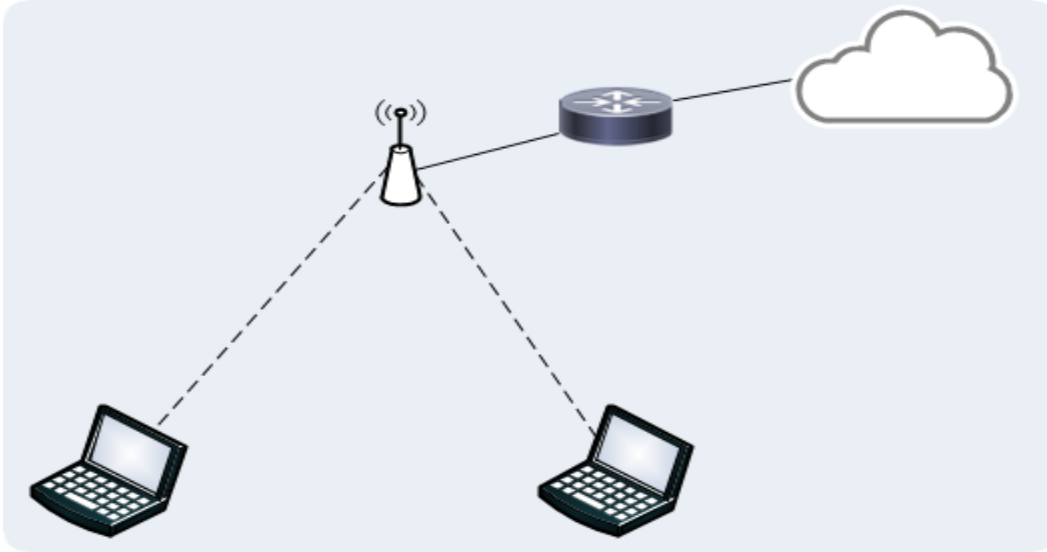

Figure 2 Basic Service Set WLAN connectivity [5]

- **Extended Services Set:** in this mode different wireless access point devices are interconnected through additional network devices.

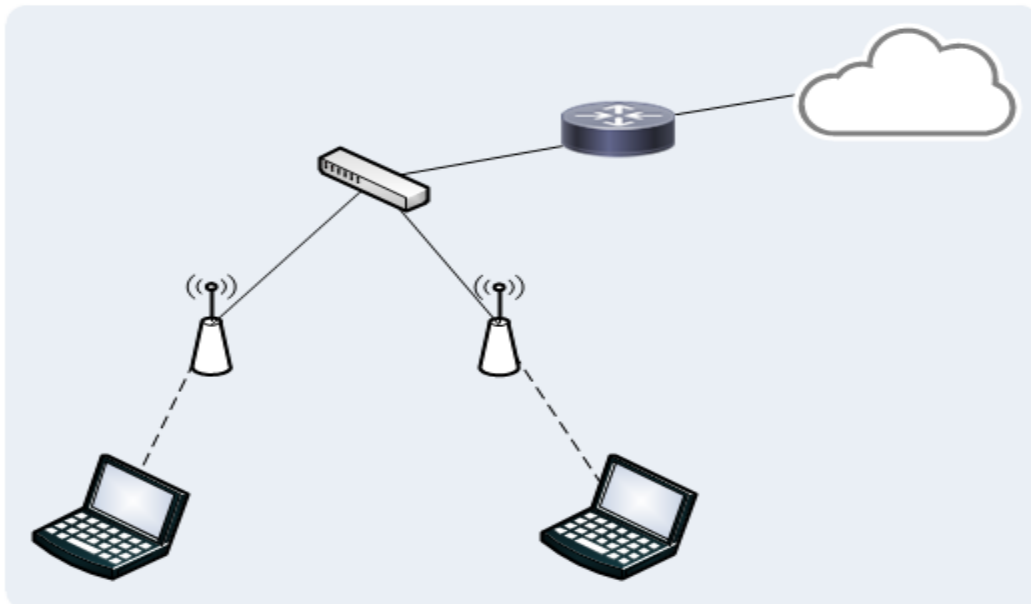

Figure 3 Extended Services Set WLAN connectivity [5]

## 2.2.2 Wi-Fi Standards

Wi-Fi operates on the unlicensed band of frequency and this will give flexible and easy to deploy without control of telecommunication companies. Some of main standards are described below.

**IEEE 802.11a:-** Operates in the 5 GHz frequency range with maximum data rates service up to 54 Mbps and uses encoding scheme of orthogonal frequency-division multiplexing (OFDM). This technology supports 23 non overlapping frequency channels. Because it works in the 5 GHz frequency range it is less susceptible to radio frequency interference.

**IEEE 802.11b:-** Operates in the 2.4 GHz frequency range with maximum data rate service up to 11Mbps. Uses direct sequence spread spectrum (DSSS) modulation technique and provides three overlapping frequency channels. This means three access points can operate in the same cell area simultaneously using three different frequency channels. The following figure shows frequency allocation of IEEE 802.11b protocol [5]

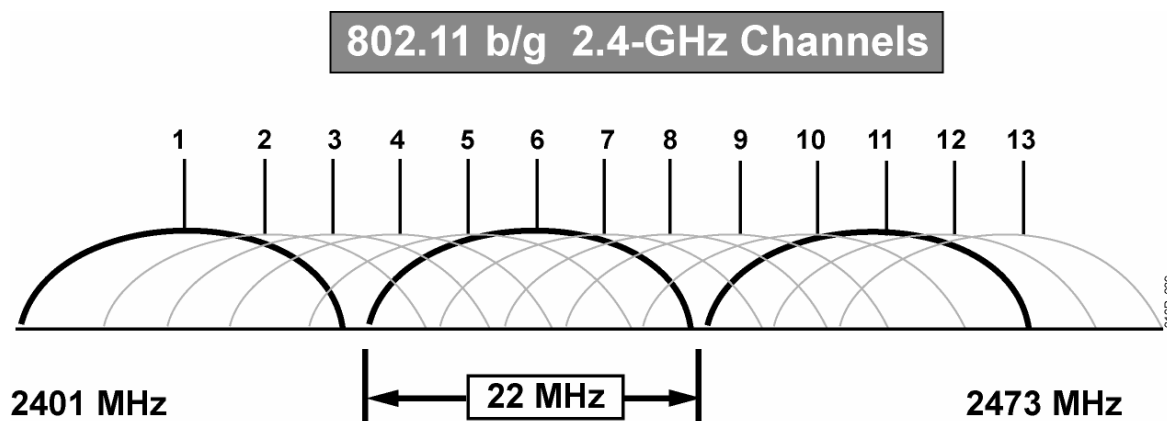

*Figure 4 IEEE 802.11b frequency band allocation [5].*

**IEEE 802.11g:-** Operates in the 2.4 GHz frequency bands and provides up to 54Mbps maximum data rate. This standard uses OFDM technology for transmission. And provides maximum three non-overlapping frequency channels.

**IEEE 802.11i:-** Security is one of main concern for Wi-Fi networks. This standard addresses security issues using different security mechanisms. In order to secure Wi-Fi network there should be valid authentication to ensure that legitimate users are connected to wireless network. And encryption in order to give privacy and confidentiality.

**IEEE 802.11n:-** Based on MIMO (multiple input/multiple output) OFDM technology provides high data rate service up to 600Mbps [6].

**IEEE 802.11ac:-** A new gigabit Wi-Fi standard and provides up to 1.73Gbps data rate service. It supports MIMO and higher modulation techniques in order to get high data rate. This standard will be ideal solution for video, data sync and backup [3].

**IEEE 802.11u:-** The main reason to introduce this standard is to make an easy integration between Wi-Fi network and cellular network [7]. Mainly this standard specifies,

- The discovery of suitable networks through the advertisement of access network type, roaming consortium and venue information
- Generic Advertisement Service (GAS) provides for layer 2 transport of an advertisement protocol's frames between a mobile device and a server in the network prior to authentication. The AP is responsible for the relay of a mobile device's query to a server in the carrier's network and for delivering the server's response back to the mobile
- Access Network Query Protocol (ANQP), which is a query and response based protocol used by a mobile device to discover a range of information, like roaming partners accessible via the hotspot along with their credential type including the hotspot operator's domain name; and extensible authentication protocol (EAP) method supported for authentication; IP address type availability and other metadata useful in a mobile device's network selection process

### **2.2.3 Service Set Identifier**

The SSID is the name of the wireless cell. It is used to logically separate WLANs. It must match exactly between the client and the access point. The access point broadcasts the SSID in the beacons. Beacons are broadcasts that the access points send to announce the available services [5].

### **2.2.4 Roaming technology in WLAN**

Roaming is one of most important parts of WLAN technology for users' mobility. Users can walk through from one access point to another without network disconnection. The WLAN consists of microcells, and the user has the ability to move freely anywhere that the RF coverage permits. Roaming is enabled by complete coverage with wireless cells. Seamless roaming across access

points allows users to maintain a connection while moving around the facility. The wireless client initiates the roaming if one of these conditions is detected [5]:

- The maximum data retry count is exceeded.
- The client has missed too many beacons from the access point.
- The client has reduced the data rate.
- The client intends to search for a new access point at periodic intervals.

### 2.2.5 WLAN Security

Since wireless network open with in coverage area any person can have access in to wireless network and unencrypted traffic will be sniffed and captured in to 3<sup>rd</sup> party person. Wireless LAN security is the protection from unauthorized access to computers using wireless networks. There are different standards and protocols to protect WLAN network [8]:

**Wired Equivalent Privacy (WEP):** a method to make a wireless link more like or equivalent to a wired connection. WEP aims to provide security by encrypting data over radio waves so that it is protected as it is transmitted from one end point to another. WEP is highly susceptible to a variety of “man-in-the-middle” attacks and session hijacks and has many vulnerabilities. Currently WEP is very weak security standards not used widely.

**IEEE 802.11i and IEEE 802.1X:** IEEE 802.11i is a secure authentication mechanisms based on IEEE 802.1X which is an encryption key management protocol and provides stronger data encryption mechanisms. IEEE 802.1X uses EAP in order to provide strong authentication between the client and the WLAN network. Thus the user must authenticate to radius server before allowed to access the WLAN network.

**EAP:** as we have seen above IEEE 802.11X requires EAP to provide both authentication and key management. Some of most popular types of EAP methods are Lightweight Extensible Authentication Protocol (LEAP), Protected Extensible Authentication Protocol (PEAP), Transport Layer Security (TLS), and Tunneled Transport Layer Security (TTLS). Each EAP types have their own security strength and weakness so in the design and implementation process we have to consider it properly [8].

- Message Digest 5 (MD5): one of the weakest EAP methods, and it doesn't provide more security to the WLAN infrastructure.

- LEAP: is the easiest two way authentication methods. But since it doesn't use certificate. it is susceptible to dictionary attacks.
- TLS: in the case of TLS there is exchange of certificate between client and access server. A TLS tunnel is then built and the client can be authenticated and encryption key material can be securely exchanged. TLS is one of the most secure WLAN authentication methods.
- PEAP does not require a certificate on the client, but will use a server-side certificate.
- TTLS: Very secure solution. It is very similar to PEAP using TLS to create a tunnel to avoid using certificates on the client.
- Flexible Authentication via Secure Tunneling (FAST): Very secure, creates a secure tunnel, and then uses a RADIUS server to authenticate the server and client.

**WPA and WPA2:** are two security protocols developed by the Wi-Fi Alliance to secure wireless LAN networks. WPA is intend to provide more security compared with WEP. WPA and WPA2 uses IEEE 802.1X for authentication and key management; and TKIP or AES cipher suites for encryption.

## 2.3 Mobile data offloading

Mobile data offloading is a mechanism to offload a cellular network to other complementary network technology in order to reduce data usage of cellular network. There are different technologies to complement mobile data traffic. Mainly Wi-Fi and femtocell are popular ones. Since Wi-Fi network is cost effective network infrastructure and uses unlicensed frequency spectrum it becomes popular offloading mechanism compared with other methods. Additionally, since Wi-Fi technology is integrated to every smart phone devices, it is easy to integrate cellular network and Wi-Fi network.

Third Generation Partnership Project (3GPP) has started to develop a 3GPP WLAN interworking architecture to allow 3GPP service providers to offload data traffic from cellular network to WLANs in indoor areas, hotspots, and other areas where high user density exist.

### 2.3.1 3GPP Release 6

#### **Interconnection between WLAN and UMTS**

Focuses on the interworking between WLAN and UMTS network and prepares a new specification on integration, security, charging and management. The I-WLAN work item defines the

interworking between 3GPP systems and Wireless Local Area Networks (WLANs). For this purpose, “3GPP - WLAN interworking” refers to the utilization of resources and access to services within the 3GPP system by respectively the WLAN UE and user. The intent of 3GPP - WLAN Interworking is to extend 3GPP services and functionality to the WLAN access environment. Thus the WLAN effectively becomes a complementary radio access technology to the 3GPP system [9]. This release provides a number of different scenarios of 3GPP-WLAN interworking ranging from common billing to the provision of services seamlessly between the WLAN and the 3GPP system. Additionally describes an approach for a flexible, general, scalable and future proof 3GPP - WLAN interworking [10]. 3GPP-WLAN integration can be deployed from simple architecture to scalable and more advanced seamless interconnection. Next we will see different network integration scenarios which are presented on 3GPP Release 6.

### **Interworking scenarios**

There are different proposed scenarios and in each scenario there are detail steps in integrating 3GPP and WLAN network. Figure 2 shows a general simplified integration model.

**Scenario 1 - Common Billing and Customer Care:** - in this scenario common billing system will be installed, where both 3GPP and WLAN network treats as a single customer. But other services like security may be independent. This scenario only provides simplified customer care service by subscribe a single billing system. I.e the customer does not required to subscribe independent billing system for WLAN and UMTS network.

**Scenario 2 - 3GPP system based Access Control and Charging:** - in this scenario WLAN network access control (authentication, authorization and accounting) mechanism will be the same as 3GPP network. Since this scenario uses the 3GPP access control and charging system both the mobile operator and customer will be easy for operation.

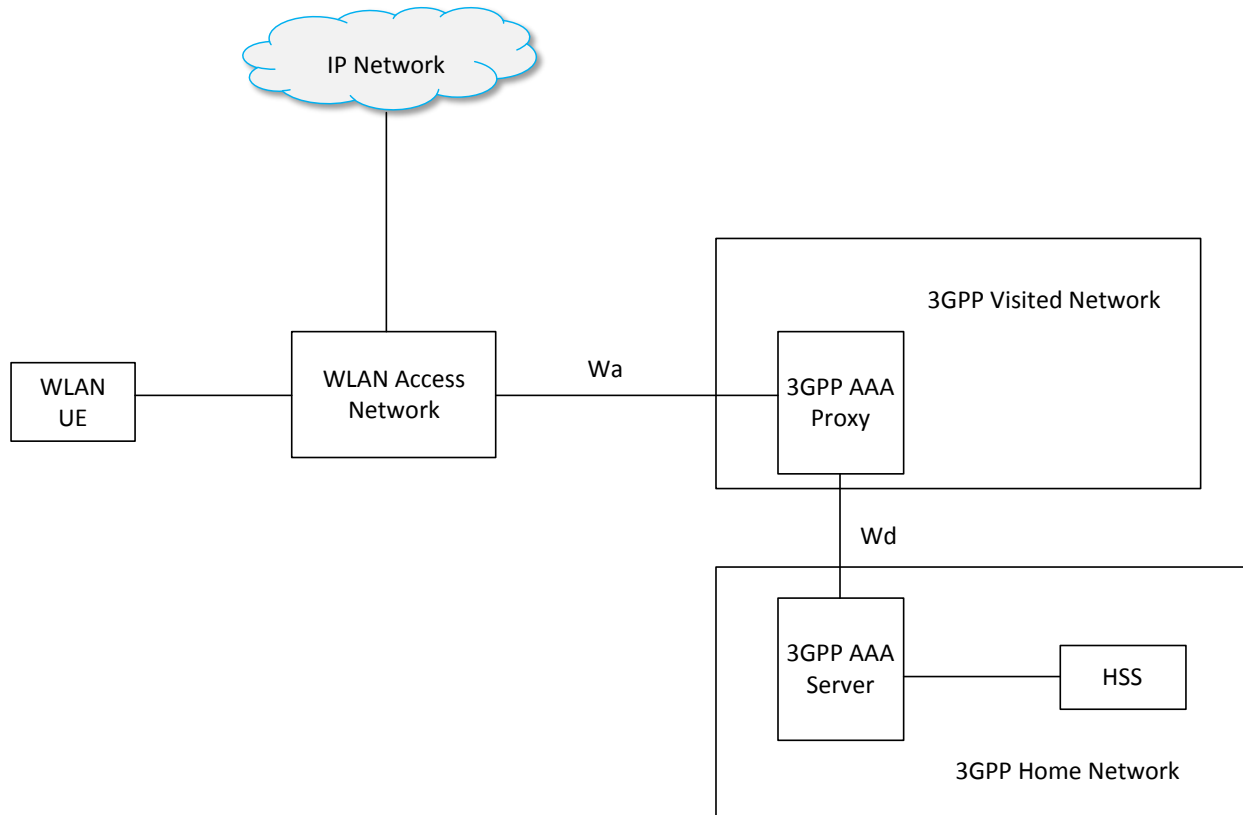

Figure 5 Scenario 2 3GPP-WLAN interworking architecture [11]

UICC smart cards with SIM/USIM applications (WLAN UE) used to authenticate the WLAN interworking terminals. In this scenario authentication, authorization will be delivered by a centralized AAA server which is connected to HSS home network in order to access user information. IEEE 802.11i provides confidentiality, integrity and access control between WLAN UE and WLAN access network. Therefore after the WLAN UE authenticated and authorized by the 3GPP network the Internet data traffic will be redirected to WLAN network in order to access Internet.

Figure 6 show how end to end EAP authentication works.

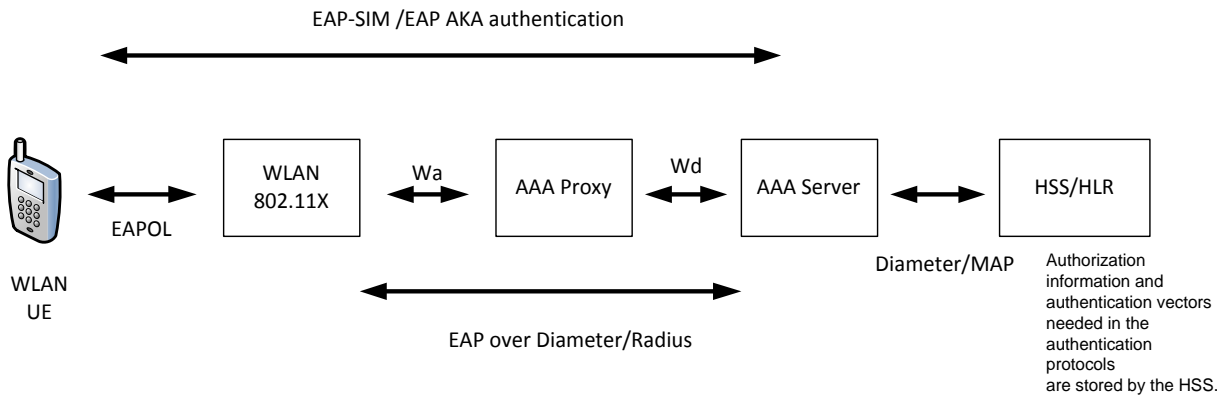

Figure 6 End to end EAP authentication [11]

### Protocols used for Authentication

The 802.1X is a specification that defines EAP (Extensible Authentication Protocol) over LAN. This is also known as EAPOL. EAP is a method of conducting an authentication conversation between a user and an authentication server. 802.11x employs the EAP as authentication framework [13]. There are different methods of implementing EAP. For the case of 3GPP-WLAN interconnection it is specified that EAP-AKA and EAP-SIM shall be used.

EAP-SIM is an Extensible Authentication Protocol (EAP) [14] mechanism for authentication and session key distribution using the Global System for Mobile communications (GSM) Subscriber Identity Module (SIM). EAP-SIM uses a SIM authentication algorithm between the client and an Authentication, Authorization and Accounting (AAA) server. EAP SIM also includes mechanisms for identity hiding using temporary identifiers, or pseudonyms, and a fast re-authentication procedure

EAP-AKA specifies an EAP method that is based on the Authentication and Key Agreement (AKA) mechanism used in 3rd generation mobile networks Universal Mobile Telecommunications System (UMTS) and CDMA2000. EAP AKA includes the same identity hiding and fast re-authentication functions as EAP SIM.

The two main protocols used for Authentication, Authorization and Accounting service in 3GPP-WLAN are RADIUS and Diameter. Both protocols provides the same functionality and can encapsulate EAP messages. But Diameter is the successor of RADIUS and was developed to overcome several limitations of RADIUS. Some improvements of Diameter are Application-layer

acknowledgments and failover algorithms, Mandatory IPsec and optional TLS supports, Reliable transport mechanisms (TCP, SCTP), Support for server-initiated messages, Data object security is supported but not mandatory, Capability negotiation between clients and servers, Peer discovery and configuration.

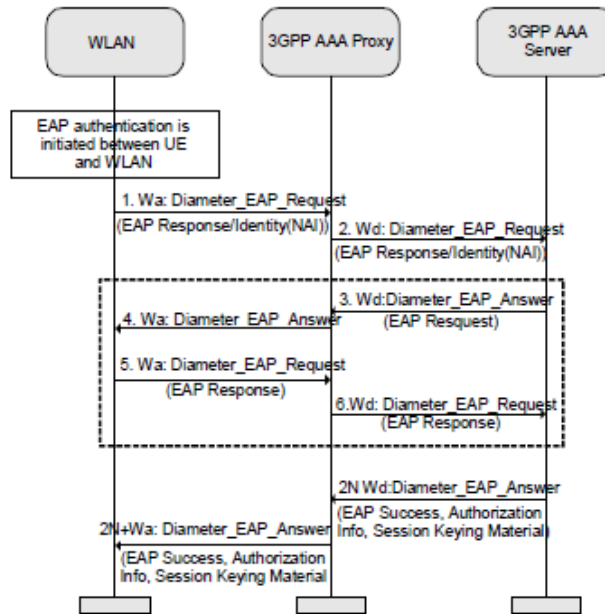

Figure 7 Authorization and authentication using diameter. [11]

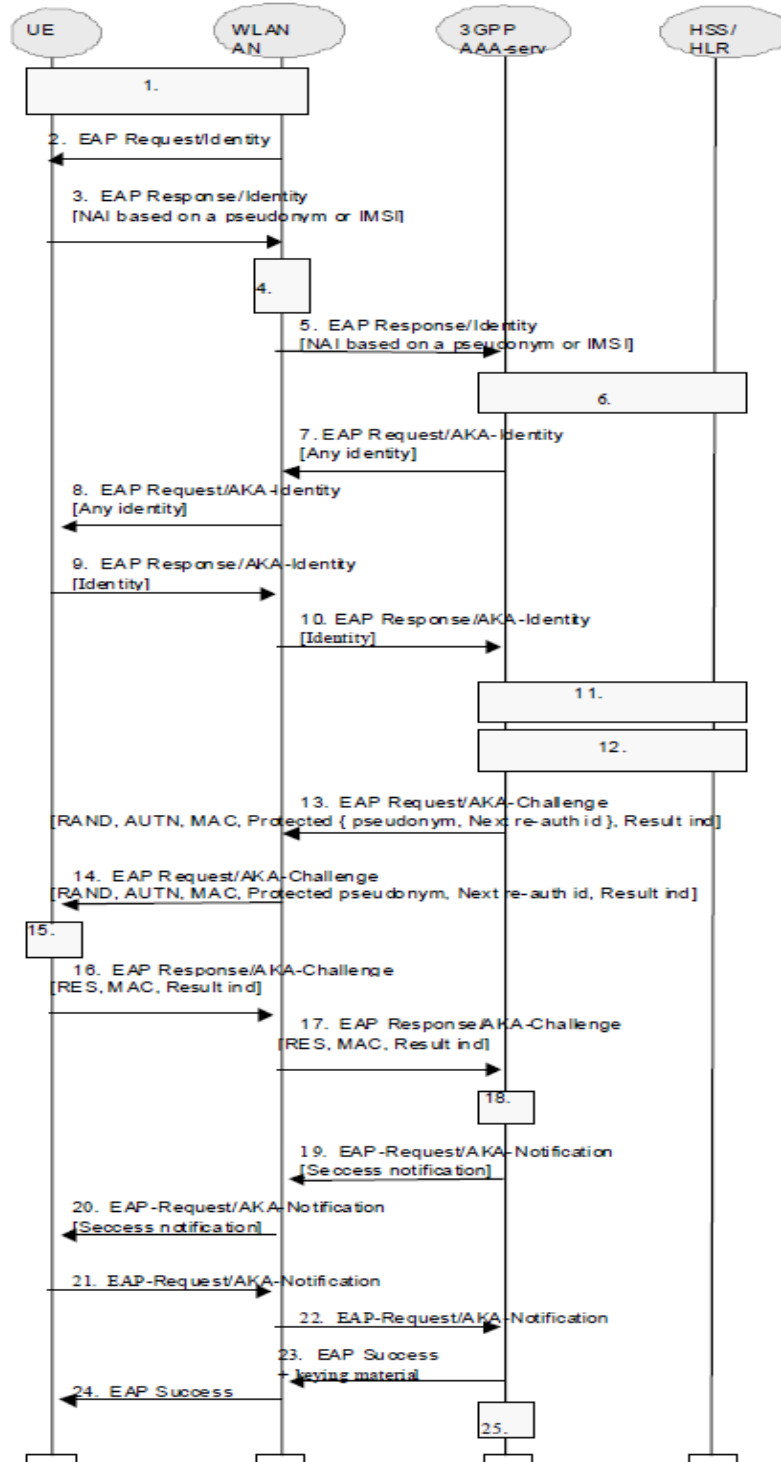

Figure 8 authentication based on EAP AKA scheme [12]

**Scenario 3: Access to 3GPP system PS based services:-**This scenario is to allow the mobile operator to spread out access to 3GPP services to WLAN access network. E.g. IMS based services,

location based services, instant messaging, presence based services. And in order to have access to the 3GPP packet-switched service from WLAN network, the user data traffic have to be tunneled between WLAN and 3GPP network. In this scenario service continuity between WLAN and 3GPP is not required [12]. The figure below shows that a complete end to end IPsec tunnel using IKEv2 protocol between WLAN UE and Packet Data Gateway will be implemented to protect user data traffic. IKEv2 have important features that EAP-SIM or EAP-AKA can be used for user authentication.

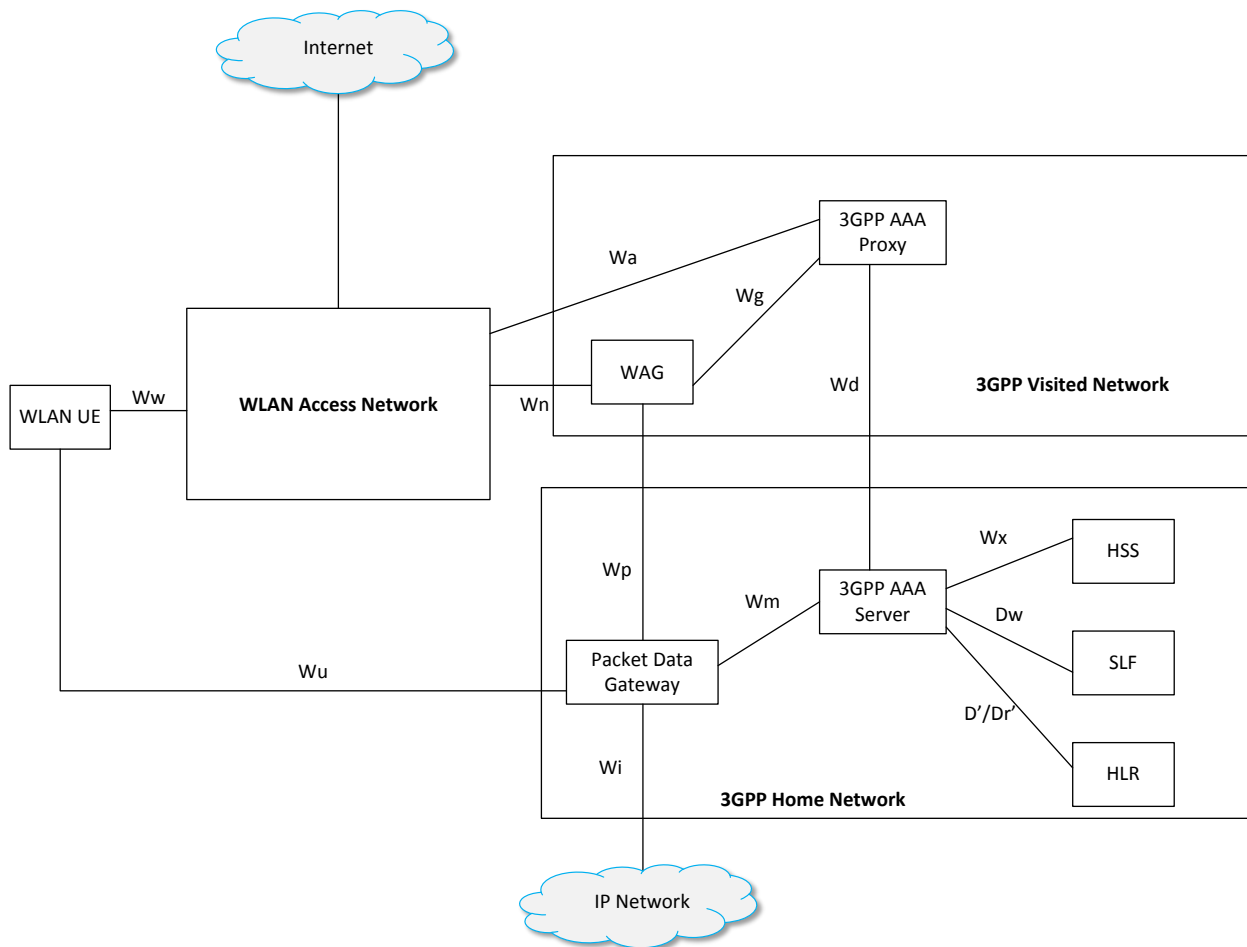

Figure 9 3GPP-WLAN interconnection architecture [12].

**Scenario 4: Service Continuity:-**here the main purpose is to provide service continuity between 3GPP and WLAN network. The user notice the translation but it is not required to reconnect the connection again.

**Scenario 5: Seamless services:-**in this scenario seamless service continuity between 3GPP and WLAN network will be provided. That is not data loss or break time service when a user changes from one network type to the other.

**Scenario 6: Access to 3GPP CS Services:-** in this scenario services provided by 3GPP circuit switch core network will be provided by WLAN network. Where any circuit-switched characteristics will not be shown to WLAN network.

**Ownership:-** the ownership of WLAN network can be the following [10]

1. 3GPP system operator.
2. A public network operator who is not a 3GPP system operator.
3. The WLAN owner is an entity providing WLAN access in a local area (i.e. building manager/owner or airport authority) but who is otherwise not a public network operator.
4. The WLAN owner is a business entity that may be providing a WLAN for its internal use that also wishes to allow interconnection, and possibly visitor use, for some or all of their WLANs.

Note: The scenarios 4, 5 and 6 are not part of 3GPP Release 6 standardization, and they are covered on the next release of 3GPP standardization.

### **Interworking Architecture [10]**

1. Non-roaming reference model
2. Roaming reference model - 3GPP PS based services provided via the 3GPP Home Network
3. Roaming reference model - 3GPP PS based services provided via the 3GPP Visited Network

### **2.3.2 3GPP Release 7**

Release 7 is mainly focused on the usage of quality of services (QoS) for 3GPP-WLAN network. 3GPP Release 6 discussed in detail when using 3GPP IP Access, a tunnel from UE to PDG is established for carrying PS based services traffic. While accessing PS based services, it is possible that data for more than one IP flow and for different services is carried in one tunnel. And since the data is encrypted inside the tunnel it is not possible to differentiate individual IP flow at

intermediate devices. Therefore the only way to apply QoS is by using DiffServ to mark different color the DS field of outer IP header at the WLAN UE or PDG [15].

### 2.3.3 3GPP Release 8

#### Introduction of ANDSF

In Release 8 specification Access Network Discovery and Selection Function framework (ANDSF) provides access network information and to enhance the way UE discovers a new non-3GPP Access Networks. It also provides mobility policies in order for the operator to guide the UE to select the proper radio technology in any given location at any given time. The ANDSF shall respond to UE requests for access network discovery information and may be able to initiate data transfer to the UE, based on network triggers [16]. In this release simultaneous connection to both WLAN and 3GPP network is not allowed. I.e. a user connected either WLAN network to offload to 3GPP network not both network. The WLAN and PLMN network access selection in Release 8 replaces pre-release 8 specification. ANDSF provides the following information [16]

1. Inter-system mobility policy: The inter-system mobility policy is a set of operator-defined rules and preferences that affect the inter-system mobility decisions taken by the UE. The UE uses the inter-system mobility policy to:
  - (I) Decide when inter-system mobility is allowed or restricted; and
  - (II) To select the most preferable access technology type or access network that should be used to access EPC.
2. Access network discovery information: when a user request network access ANDSF provides a list of available access network technology and the radio access network identifier or SSID for the case of WLAN.

As shown figure 10 ANDSF server is one of the components of EPC network and the communication between UE and ANDSF is over the S14 interface.



Figure 10 ANDSF architecture [16]

### **EPC-WLAN architecture.**

Release 8 introduce the integration of EPC and WLAN network. The Evolved Packet System is a higher-data-rate, lower-latency, packet-optimized system that supports LTE, UMTS and other different RATs. And supports service continuity of subscriber IP sessions during in UE handovers from one IP access network to another IP access network, regardless of whether the new IP access network supports the same version of IP as the old IP access network. [17].

There are two different IP access procedures a WLAN or non-3GPP network connect to EPC network. These are trusted and non-trusted access. It is up to the operator to decide whether it is trusted or not [18].

#### **Trusted WLAN access**

Trusted WLAN access assumes that there is a secure encrypted communication with encryption between WLAN radio access network gateway and EPC including secure authentication mechanism. Hence it is not necessary to set up an additional IPsec tunnel between the UE and the EPC network. In this architecture communication to PDN-GW is connected through S2a interface and connection to AAA server is connected through STa interface.

#### **Non-trusted WLAN access**

Non-trusted EPC access is the evolution of the previous release 6 3GPP-WLAN interworking, where the functionality of PDG is evolved to ePDG. In the untrusted access case the user set up secure IPsec tunnel using IKEv2 between UE and ePDG. And the ePDG is connected to the PDN GW through S2b interface, where each user session is transported through a secure tunnel (GTP or PMIP). The PDN-GW provides a common data service gateway service WLAN and 3GPP network and performs policy enforcement, packet filtering for each user, charging support, lawful interception and packet screening. Another key role of the PGW is interface with the outside packet data networks, for example the IMS (Internet multimedia server) and the Internet [19]. Therefore As per request of the services, PDN-GW sends the traffic to the operator IP services (IMS, PSS) or redirects to the Internet. Other Wi-Fi traffic may be locally broken out at the WLAN. Before a data traffic communication started access authentication signalling should be implemented between UE and 3GPP AAA server or Proxy AAA server in case of roaming scenario. This 3GPP based access authentication is implemented across a SWa reference point and the Tunnel authentication used to create IPsec tunnel between UE and ePDG is connected across SWm reference point as shown in the figure 11 [16].

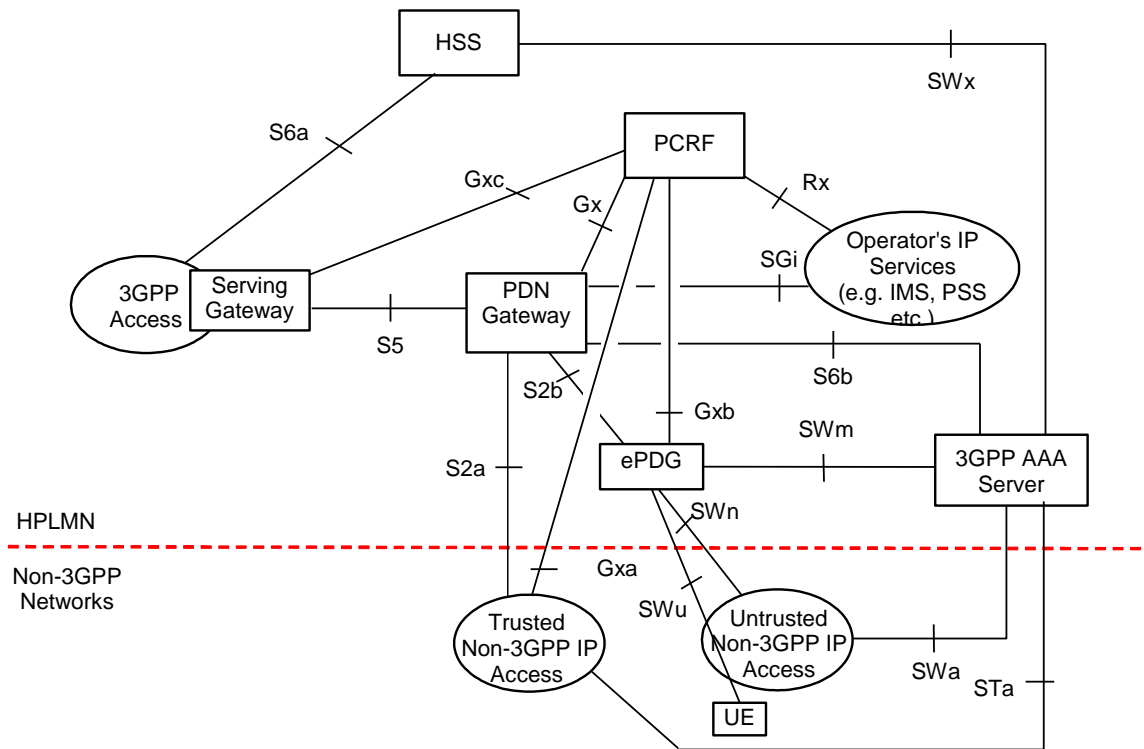

Figure 11 Non-Roaming Architecture within EPS using S5, S2a, S2b [16]

### IP Mobility between 3GPP-WLAN

IP mobility between 3GPP and non-3GPP network is first implemented in release 8 specification. IP Mobility between 3GPP and WLAN network provides uninterrupted services for users moving from one RAN to another. The main target of IP mobility is to preserve the IP address of UE in order to continue the service without downtime. There are two types of IP mobility. These are Network Based Mobility (NBM) and Host based mobility (HBM).

#### Network Based Mobility:

NBM mechanism is used for establishing connectivity in the target access upon inter-access mobility, IP address preservation for session continuity based on NBM may take place as per PMIPv6 specification, [20] and additionally based on the knowledge in the network of UE's capability (if available) to support NBM. Such knowledge may be based on an explicit indication from the UE upon handover that IP address preservation based on NBM management can be provided [16].

### **Host based mobility**

In the HBM IP address preservation take place when the network is aware of the UE capability to support DSMIPv6 or MIPv4. Such knowledge may be based on an indication to the target trusted non-3GPP access or ePDG from the HSS/AAA (e.g. in case of DSMIPv6, the UE performed S2c bootstrap before moving to the target trusted non-3GPP access or ePDG) [16]. In such a case, the trusted non-3GPP access network or ePDG provides the UE with a new IP address, local to the access network if IP mobility management protocol selected is DSMIPv6. In that case, in order to get IP address preservation for session continuity, the UE shall use DSMIPv6 over S2c reference point. This IP address shall be used as a care-of address for DSMIPv6. If the IP mobility management protocol selected is MIPv4, the address provided to the UE by the non-3GPP access network is a FACoA and IP address preservation is performed over S2a using MIPv4 FACoA procedures [16].

The final decision on the mobility management mechanism is made by the HSS/AAA upon UE authentication in the trusted non-3GPP access system or ePDG (both at initial attachment and handover), based on the information it has regarding the UE, local/home network capabilities and local/home network policies. If the UE provided an explicit indication of the supported mobility mechanisms, the network shall provide an indication to the UE identifying the selected mobility management mechanism [16].

## **2.3.4 3GPP Release 9**

### **ANDSF enhancement**

Release 9 mainly provides enhancement for Release 8 ANDSF discovery and communication. This enhancement provides Release 8 ANDSF procedures to cover also roaming scenarios, i.e. the discovery and communication with ANDSF server while UE is attached in VPLMN. Additionally ANDSF security architecture is enhanced by using of GBA-Push mechanism for push-based ANDSF security establishment. This requires changes to the push-based security establishment ANDSF procedures for Rel-9 [21].

## **2.3.5 3GPP Release 10**

When the UE have both WLAN and 3GPP network coverage, it is important for the operator to offload some traffic (e.g. best effort) to the WLAN access. At the same time it may be beneficial

to still keep some traffic (e.g. VoIP flow) in the cellular access. With this IP flow mobility solution the operator can lower its data access costs while the subscriber just experiences maximised bandwidth without any service disruption or interruption [22]. Therefore the main objectives of release 10 is to provide simultaneous network connections to multiple radio access technologies using Multi Access PDN Connectivity (MAPCON), IP Flow Mobility (IFOM) and non-seamless Wi-Fi offload and to extend ANDSF framework to handle these simultaneous connections.

## MAPCON

Multi Access PDN Connectivity (MAPCON) provides simultaneous network connections to multiple radio access technologies managed by multiple PDN connections and when the UE has multiple IP addresses for each PDN. Using MAPCON mobile offloading will take place easily instead of requiring the UE to support multiple client-based mobility management like DSMIPv6. One of the examples of MAPCON is when a UE can transfer FTP and other best effort Internet connections using WLAN network and other web and VOIP connections will be transferred to 3GPP networks. The following figure shows MAPCON connectivity [15]

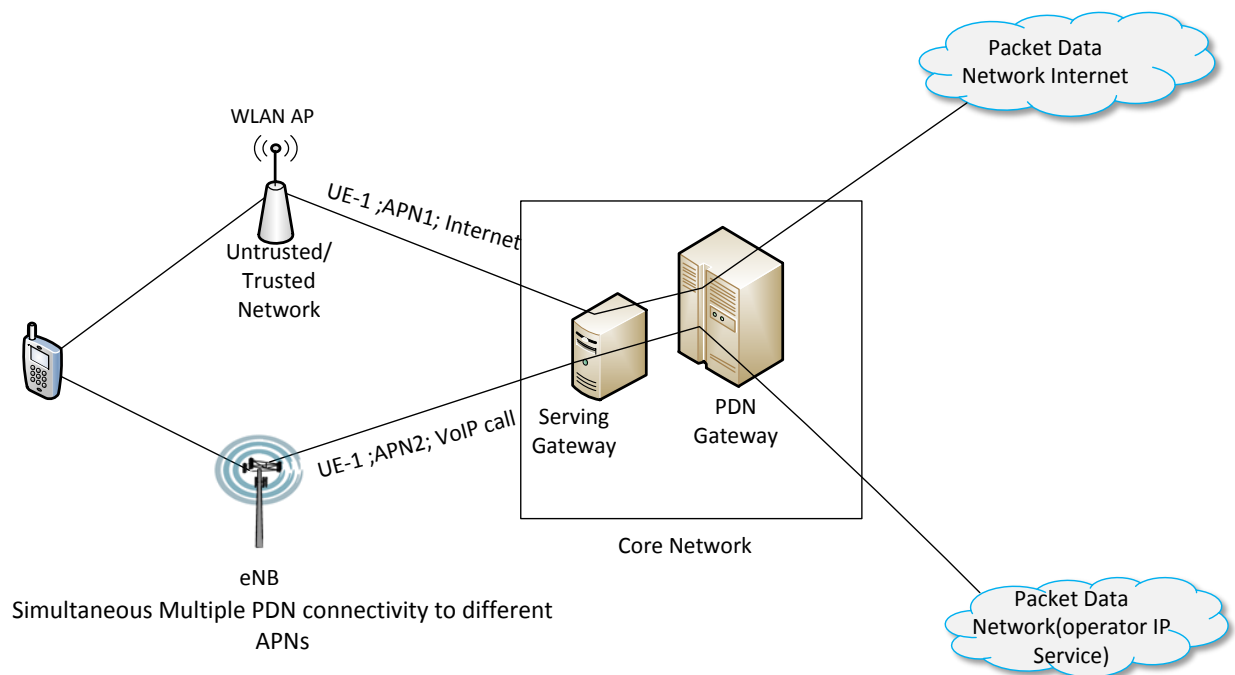

Figure 12 multi access PDN connectivity [15]

## IP flow mobility and seamless WLAN offload (IFOM)

IP flow mobility provides Simultaneous connection to 3GPP access and WLAN and exchange different IP flows belonging to the same PDN and provides movement of IP flow from one access network to another. The solution is based on DSMIPv6 and IP address preservation and session continuity is provided when moving IP flows from one access network to another. By using Policy provisioning the operator informs the UE which network access technology the IP flow is routed. And By using DSMIPv6 IP address processing, the session can be maintained without knowledge of the different network paths. In the same way as MAPCON, downloading large files using FTP is performed via the WLAN network while voice calls using VoLTE and video calls are handled via the 3GPP network.

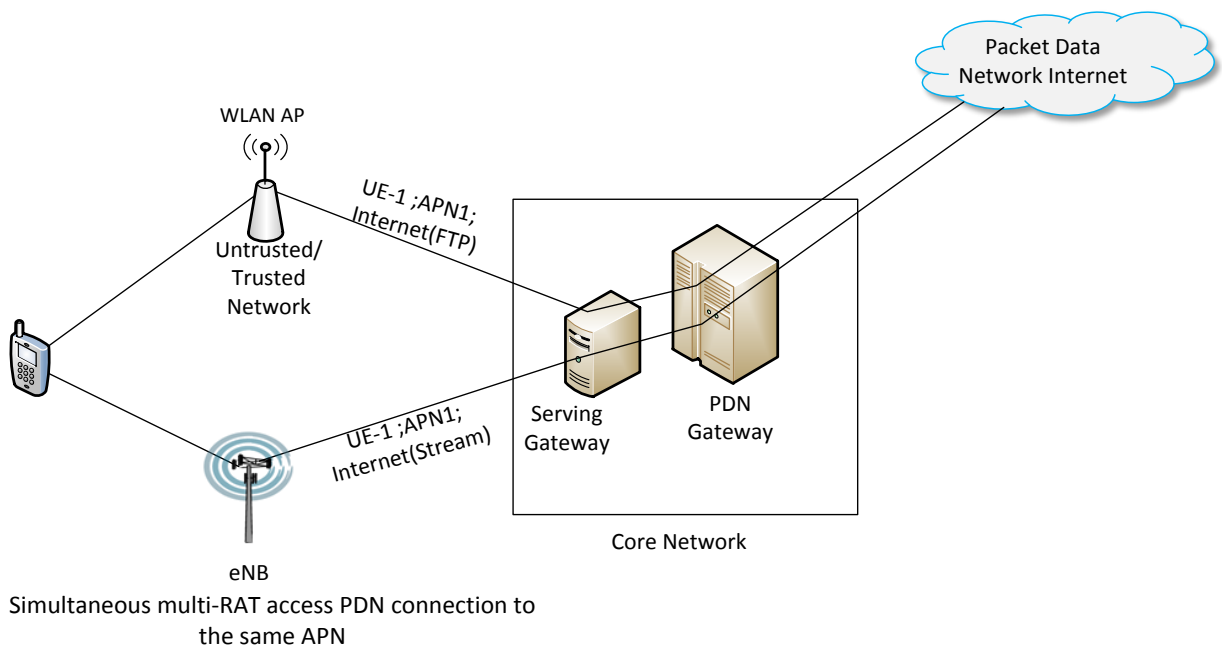

Figure 13 IP Flow mobility [15]

Using IFOM extensions, the offloading of different data flows described in Figure 14 can be realized: Depending on the availability and quality of the access technologies, different flows can be offloaded to WLAN while keeping the LTE connection running. In this example, the (real time)

video stream is kept on LTE, while the VoIP, Web and FTP connections are offloaded to WLAN [18].

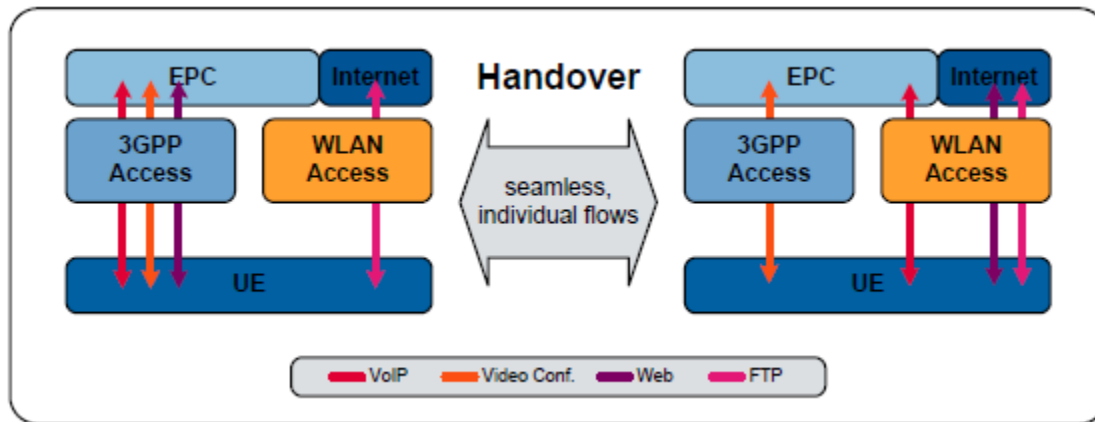

Figure 14 WLAN offloading for different data flow using IFOM [18]

### Non-seamless offloading.

In Non-seamless offloading UE that is connected to WLAN access, route specific IP flows via the WLAN access without traversing the EPC. For such IP flows the UE uses the local IP address allocated by the WLAN access network and no IP address preservation is provided between WLAN and 3GPP accesses. The following figure shows show that a subscriber who is using 3GPP network is offloaded to WLAN network.

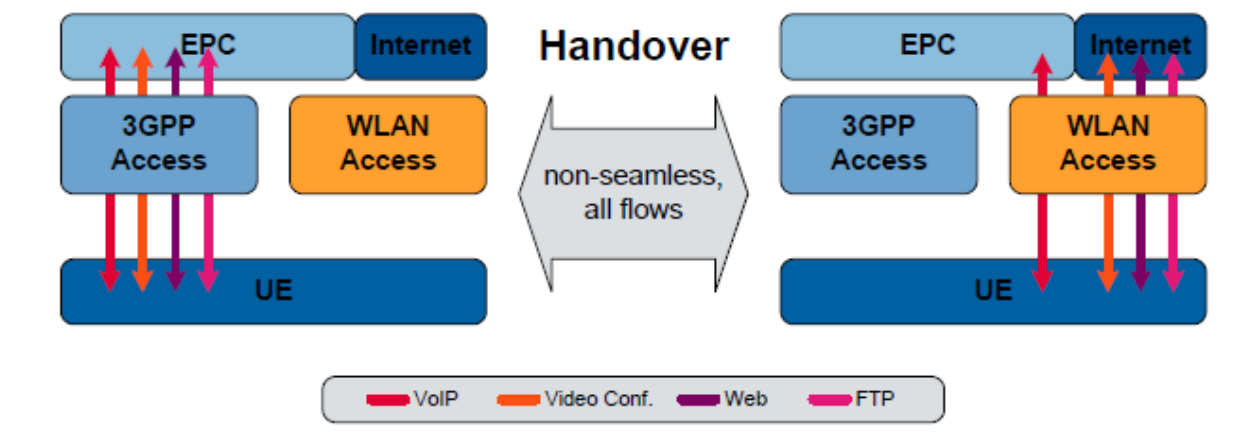

Figure 15 non-seamless IP mobility [18]

## Extensions to the ANDSF framework

Generally the information addressed by ANDSF to UE are inter-system mobility policy (ISMP), the access network discovery information and the inter-system routing policy (ISRP). The ANDSF may provide all types of information or only one of them. Both ISMP and access network discovery information are covered in release 8 specification. In Rel-10 ANDSF provides a list of ISRP to UE in order to transmit IP traffic simultaneously over multiple radio access interfaces. The ISRP contains the following three information

1. **IFOM rule:** provides filter rule identifying prioritized access network and also identifies which radio accesses are restricted for traffic that matches specific IP filters on a specific APN (e.g. WLAN is not allowed for RTP/RTCP traffic flows on APN-x) or on any APN [23].
2. **MAPCON:** provides filter rule identifying prioritized access network and a filter rule also identifies which radio accesses are restricted for PDN connections to specific APNs (e.g. WLAN is not allowed for PDN connection to APN-x) [23].
3. **Non-seamless WLAN offload:** Filter Rules, each one identifying which traffic shall or shall not be non-seamlessly offloaded to a WLAN when available.

After operators indicate different preferred or forbidden radio access technologies as a function of the type of traffic the UE sends. Specifically an ISRP can be based on:

- The PDN identifier (i.e. APN) the UE uses for a given connection;
- The destination IP address the UE sends traffic to;
- The destination port number the UE connects to;
- A combination of the three elements above.

### 2.3.6 3GPP Release 11

Release 11 introduce the support of Broadband Forum Accesses network Interworking. The interworking between a 3GPP system and a Fixed Broadband Access network defined by Broadband Forum to provide the IP connectivity to a 3GPP UE using a WLAN and a H(e)NB connected to a Fixed Broadband Access network. The specification also provides mobility, Policy,

QoS aspects between 3GPP and a Fixed Broadband Access network as well as the respective interactions with the PCC frameworks [24].

There are some enhancements done in Rel-11 specifications. The first enhancement is on Data Identification in ANDSF. Since Rel-10 specification have limitation on how the traffic is identified due to the clear of aggregation of the Internet traffic into few transport ports. For example the operator with the Rel-10 framework is not able to discriminate between video streaming (e.g. www.youtube.com) and web browsing (e.g. www.google.com) [25].

Therefore this release specify ANDSF extensions to provide to operators a better control of the network resources used for each application or IP flow. Specifically this WID will specify:

- Additional ways to identify classes of traffic an ISRP applies to.
- Extensions to the ANDSF MO to convey these additional ways over S14.

Additionally FQDN representation of traffic and Application-ID representation of traffic is included in ANDSF.

Based on the requirements from the operators to use GPRS Tunnelling Protocol (GTP) based S2a for WLAN to access EPC, 3GPP supported GTPv2 over S2a, under S2a Mobility based on GTP (SaMOG) work item. The use of GTP based S2a or PMIPv6 based S2a for the WLAN to access the EPC depends on the operator's network deployment policy [15].

### **2.3.7 3GPP Release 12**

In Prerelease 12 specifications UEs using WLAN networks controlled by 3GPP operators and their partners often make suboptimal offload to/from WLAN decisions resulting in poor user experience and inefficient resource utilization of operator's networks [26]. Therefore in order to improve WLAN utilization when it is available and not congested, in this release proposed a solution to improve WLAN/3GPP access network selection and traffic steering that addresses requirements from all operators. The solution supports deployments with and without ANDSF and supports co-existence of ANDSF with RAN rules when both are deployed.

Additionally The Hotspot 2.0 solution developed by WFA builds on the architecture and set of protocols defined by IEEE 802.11u and develops key capabilities for network discovery and selection of WLAN terminals based on the ANQP (Access Network Query Protocol) defined in

IEEE 802.11u. Hotspot 2.0 is focused on enabling a mobile device to automatically “discover” APs that have a roaming arrangement with the user’s home network and then securely connect. Hotspot 2.0 facilitates the seamless mobility of users from one WLAN to another or from Cellular RAN to WLAN and vice-versa, with minimal or no user intervention [27]. Release 12 proposed 3GPP network support for network selection for WLAN networks taking into account WFA Hotspot 2.0 solutions.

For both Access Network Selection and Traffic Routing Selected cases RAN assistance parameters transferred to UE via system broadcast and/or dedicated signaling and the UE decides accessing WLAN or 3GPP network by RAN assistance information, UE measurements, Information provided by WLAN, Policies obtained via the ANDSF or via existing OMA-DM mechanisms or pre-configured at the UE.

RAN Assistance Information contains WLAN and RAN Thresholds, Load Information, Resource Allocation and Traffic Information ( LTE-WLAN Interworking: 3GPP Release-12 Perspective).

### **2.3.8 3GPP Release 13**

Release 13 specification introduces new technologies and enhancement from release 12. Specific to WLAN offloading Rel-13 shows Improvements in Radio Access Network (RAN) implementation makes LTE and WLAN Aggregation (LWA) and where Wi-Fi can now be supported by a radio bearer and aggregated with an LTE radio bearer. Additionally Rel-13 introduces Wi-Fi integration enhancements to support Network-Based IP Flow Mobility (NBIFOM) enhancements to harmonize the support of voice and video services over Wi-Fi.

Pre Rel-13 specification support that, a UE can connect to both WLAN and 3GPP network simultaneously using different PDN network. And 3GPP defined the capability for DSMIPv6 capable UEs to allow seamless offload of individual IP flows corresponding to a PDN connection to WLAN by introducing IP flow mobility (IFOM) support to the EPC. Since many mobile operators started deploying network-based mobility protocols (e.g. GTP and PMIP). Hence in Rel-13 seamless offload and flow mobility using network-based protocol, PMIP and GTP based S2a and S2b over WLAN is introduced.

## **LTE-WLAN RADIO LEVEL INTEGRATION**

3GPP/WLAN radio interworking Release-12 solution enhances core network based WLAN offload by improving user QoE and network utilization and providing more control to operators. And these improvements can be further enhanced by LTE/WLAN integration at radio level [29].

The following LTE-WLAN Radio Level Integration features are standardized in Rel-13 specification.

**LTE-WLAN Aggregation (LWA):** LTE WLAN Ag (LWA) allows the integration of WLAN and LTE network at RAN level. I.e. WLAN access point interacts to LTE eNB and no direct interaction with core 3GPP network [30]. LWA enables LTE and WLAN interworking with data aggregation at the radio access network, using an LTE dual-connectivity like framework. Here an eNB schedules packets to be served on LTE and Wi-Fi radio links. In essence, to achieve enhanced performance, the LTE data payload is split, with some traffic tunneled over Wi-Fi and some transmitted over LTE [31]. LWA enables LTE and WLAN interworking with data aggregation at the radio access network, using an LTE dual-connectivity like framework.

**LTE-WLAN Radio Level Integration with IPsec Tunnel (LWIP):** this will provide direct IPsec tunnel between UE and LTE eNB. This IPsec tunnel is important to support any legacy WLAN network infrastructure by hiding WLAN access point [32].

**RAN Controlled LTE WLAN Interworking (RCLWI):** RCLWI still uses CN-based offloading but the eNB can make the decision to steer traffic between LTE and WLAN which can provide better performance compared to previous CN based solutions. RCLWI is also based on WT and Xw interface upgrade of the WiFi network for control signaling, however, the User Plane (UP) bearers instead of going through the LTE eNB are routed through a CN with WiFi legacy link. This is rather a bearer handover (or an offload) than an aggregation compared to LWA, however still the UE is controlled by the network to receive the data from WiFi link, instead of taking this decision by itself. Compared to LWA, this solution doesn't require the UE to be upgraded with LWAAP [32].

### 2.3.9 3GPP Release 14

As we have seen above, 3GPP Release-13 (Rel-13) introduces interworking or aggregation between WLAN and LTE using LWA, LWIP and RCLWI. Rel-14 builds based on Rel-13 LWA framework and architecture, introduces enhanced LAA (eLAA), enhanced LWA (eLWA) which optimizes the WLAN-LTE integration. Mainly eLWA focuses on the following points [32]

1. Uplink data transmission on WLAN, including uplink bearer switch and bearer split
2. Mobility optimizations, e.g., intra and inter eNB handover without WT change and improvements for Change of WT
3. Potential enhancements to support 60 GHz new band and channels (e.g., in measurements) and increased data rates for 802.11ax, 802.11ad, and 802.11ay (e.g., by PDCP optimizations)
4. Additional information collection and feedback e.g., for better estimation of available WLAN capacity (by additional signaling on both Uu and Xw) to improve LWA performance
5. Automatic Neighbor Relation (ANR) for LWA e.g., for discovery of WLANs under eNB coverage.

## 3.0 WLAN design

Since the introduction of WLAN 1997 [4], its capability and availability is growing for indoor and outdoor areas. WLAN introduced to provide any service through the air from anywhere in the range of wireless access point equivalently that a wired LAN can provides. From time to time more number of Wi-Fi enabled devices enter the market and also the average number of users in a given access point increases. In designing and planning WLAN network it is important to consider different factors. Some of the things we need to consider are the types of traffic, amount of traffic throughput, the number of clients in the network, number of access points that provides required area coverage and bandwidth. Especially in a very highly densely environment it is very important to consider the WLAN coverage, performance, management and security issues properly. Additionally satisfactory performance and throughput for all users and applications need to take account. This chapter also focus designing WLAN network in a very high density environment.

### 3.1 Wi-Fi Coverage and capacity

Most Wi-Fi networks are designed and implemented for indoor environment like office building, schools, cafes, hospital etc. The wireless coverage that a user access should not compromise the total capacity of WLAN network. In designing WLAN in densely populated public area is a little different compared with indoor places. Highly densely environments are wide in coverage and more peoples are entertained in a given access point.

In highly densely environments access points are deployed close to each other and WLAN performance can be degraded by RF interferences. In order to mitigate RF interference and meet the design targets, it is important to consider the following points [33]

- Increase the use of 5GHz RF spectrum: Wi-Fi network connections use either 2.4 GHz or 5GHz frequency band. 5 GHz has a shorter range than 2.4 GHz but its frequency reuse factor reaches up to 12 and this provides more capacity can support much higher speeds and also less susceptible to interference due to the small amount of devices that use this range. The Wi-Fi trend shows that 5 GHz RF spectrum usage is increasing, currently manufactured WLAN devices also support 5GHz RF spectrum. Especially in a very

densely environment frequency re-use factor is important in order to mitigate co-channel interference.

- Decrease cell size as much as possible: decreasing cell size reduces the co-channel interference between WLAN access points that use the same frequency band and increase the capacity of the whole WLAN network. In highly densely environment it is important and recommended to decrease the cell size as much as possible, and since there will be more number of users in a small area, capacity is more important compared with coverage.
- Increase Access point number: proper estimation of access points is important to increase the WLAN coverage and capacity, but it is important to plan the optimum number of access points in a given area.
- Frequency re-use: it is a good practice to increase the frequency re-use in order to increase the WLAN capacity. As we have seen above 5 GHz frequency spectrum has more frequency re-use factor than 2.4GHz frequency spectrum. This will reduce the co-channel interference between access points.

Antenna selection is also very important for both coverage and capacity. We need to select antenna type and pattern by not compromising both coverage and capacity.

RF simulation tool and site survey: a good RF simulation tool and site survey is important to assess all the above factors before implementing the WLAN. This will provide necessary information about Wi-Fi coverage area, RF interferences in the area and to identify the placement of access points. The following table shows coverage vs capacity comparison.

Factors	Coverage	Capacity
Number of APs	Prefer Low	Prefer high
Limiting factor	Path loss	Interference
Obstacle	Bad	Good
RF frequency	Lower is better	Higher is better
Antenna pattern	Omni is better	Sector is better
AP placement	Higher is better	Lower is better
Design metric	SNA area	SINR area

Table 1 coverage vs capacity [33]

### 3.2 Identify application throughput

Identifying types of devices and applications that will be running over the wireless network is helpful in planning for the WLAN. Different types of applications have varying response time. Some applications are very delay sensitive and others are not. Interactive applications like voice and video are very delay sensitive with round trip delay of less than 150ms. Other applications like email, web browsing and file downloading can tolerate delays of a few seconds. So in the design of WLAN network we have to consider different types of applications and their bandwidth usage.

Application type	Bandwidth
Web – Casual	500 kilobits per second (Kbps)
Audio – Casual	100 Kbps
Audio - Instructional	1 Mbps
On-demand or Streaming Video - Casual	1 Mbps
File Sharing - Casual	1 Mbps

Table 2 application requirement [33]

### 3.3 Key performance indicators

In designing WLAN network the following KPI (key performance indicator) metrics are important in order to measure a successful deployment. If one of KPIs is not properly considered poor performance will be resulted and users will not be satisfied. Recommended WLAN KPIs are the following [33],

- Type of application supported
- Minimum bandwidth required by a given application
- Min, average and maximum number of Wi-Fi enabled devices
- Expected number of active Wi-Fi users
- Quality of service
- Service areas

### 3.4 Estimating number of Client and AP Counts

Estimating the number of users that connect to a single access points and the access point numbers for a given coverage area depends on the factors that we have on the above sections. Different Wi-Fi protocols have different performance and capability. An 802.11ac and 802.11n capable devices can provide higher throughput compared with older 802.11a/b/g standards. The following table shows a summarized maximum throughput statistics that Wi-Fi enabled device can support.

Wi-Fi standard	Channel bandwidth (MHz)	Max Physical Rate (Mbps)
802.11b	20	11
802.11g	20	54
802.11n	20	54
802.11n (1x1:1)	20	72.2
802.11n (1x1:1)	40	150
802.11n (2x2:2)	40	300

Table 3 Wi-Fi capability [33]

Physical rate is the maximum throughput of raw data. Physical rate works in the data link layer of TCP/IP model and different from application throughput. Application throughput decreases by additional datalink headers. Other WLAN management traffic also decreases the total performance of WLAN. In the design of WLAN, it is important to consider the application throughput not the physical data rate. As an example 802.11g standards have 54Mbps physical data rate speed but all the TCP/IP overhead decrease the overall throughput decreases to 20Mbps. Some protocols like UDP have lower TCP/IP header so it provides higher throughput. Other encryption methods also decreases the throughput. There is no precise calculation to know the exact throughput of WLAN standards. It can vary based on the protocol the client uses. Further it can also vary because of congestion and interference [33].

#### 4.3.1 Estimate access point throughput

Identifying the maximum data rate of a given AP is important for determining how fast a client devices can transmit and receive data. This will have a big impact on the amount of airtime utilized

to achieve the target application throughput level and overall network capacity planning. Since WLAN protocol incorporates different network overhead, the theoretical maximum Wi-Fi data rate does not represent the actual application throughput that a given user achieve. To estimate the maximum amount of TCP/IP throughput that a client is capable of achieving, the amount of network overhead must be determined either through live network testing under load or through an educated assumption. It is common for Wi-Fi networks to have between 40-60% overhead [42]. The estimated access point throughput can be calculated as shown below [33]

$$y = x - (x * 0.4) = 0.6 x \quad (3.1)$$

$$n = y * 0.35 = (0.6 * 0.35) x = 0.21 x \quad (3.2)$$

$$z = y - n = 0.6 x - 0.21 x = 0.39 x \quad (3.3)$$

Where  $z$  is estimated access point throughput,  $y$  is TCP/IP throughput,  $x$  is maximum PHY Rate,  $n$  is loss from interference

As we have seen above TCP/IP header can have 40% overhead, which is subtracted from physical data rate. Additionally the throughput in densely populated public environments can be reduced due to network collision. It is very difficult to know the exact number but in densely environment it is important to use a lower number with 35% of the throughput.

Currently there are different 802.11 standards but implementing 802.11n standards have benefit from both capacity and widely integrated in to WLAN equipment's. Although new standards like 802.11ac provide a very high bandwidth compared with all the previous WLAN standards, it is difficult to consider it in the design at this time because of most smart phones doesn't support it except newest one.

Since in highly densely environment there will be more access points; co-channel interference between access points will be high. The same kind of interference can be created because of many number of WLAN users. Higher modulation techniques offer higher data rate and spectral efficiency. But higher order modulations are more affected by noise and interference. And because of that not all WLAN users can't use higher modulations rates always. Hence in the design we will assume a WLAN users will use average modulation rates. Therefore a single access point using weighted average modulation rate will have the following throughput.

Using equation 3.1, the TCP/IP throughput become

$$y = 72.2 \text{ Mbps} - (72.2 \text{ Mbps} * 0.40\%) = 43.3 \text{ Mbps}$$

Using equation 3.2, the loss from interference is

$$n = y * 0.35 = 15.16 \text{ Mbps}$$

Using equation 3.3, therefore the total access point throughput is

$$z = 43.3 - 15.16 = 28.12 \text{ Mbps}$$

Dual-band access points with two radios can simultaneously support both 2.4 GHz and 5 GHz RF bands. And this will increase the total throughput a given access point can deliver.

### **Estimating clients per AP capacity:**

The maximum number of clients in a single AP can be calculated below [33]

$$k = l / n \tag{3.4}$$

Where  $k$  is number of client per AP,  $l$  is access point aggregate throughput and  $n$  is minimum bandwidth per client

Therefore the total number of APs required to cover a given area will be

$$s = t / k \tag{3.5}$$

Where  $s$  is the total number of access point and  $t$  is total number of active users.

The total number of APs required can be affected by the distance that a client is placed, access point coverage and But for the case of very highly densely areas it is very recommended to use small coverage and use directional antenna when needed in order to boast the overall performance.

### **Access point location**

As a good practice access points should be mounted close to clients as much as possible. The RF signal strength is proportional to Inverse Square of distance. Hence when a client become far away from AP the RF signal strength degrades very fast. A client which is 20m far away from AP receive a signal  $\frac{1}{4}$  (-6dB) of a client with 10m faraway [33].

In highly densely environment the APs coverage area should be small in order to increase the capacity. Additionally this increases the performance and allows for the implementation of narrower beam antennas that can increase signal gain. More APs also increases the receive signal for clients since there are more APs closer to any client location. This has the benefit of better SNR, which is required for high performance and capacity. In order to have higher signal gain directional antennas are recommended in the public areas. This will help us to reduce the RF interference also.

## 4.0 Implementation consideration

As we have seen on mobile data offloading section, Wi-Fi network can be integrated and work with all cellular network technologies including LTE advanced. In Ethiopia currently 4G LTE coverage and usage is not widened enough compared with 3G UMTS network. The 3G UMTS network have good coverage on all over the country. Additionally almost all current smart phones have built in 3G network integrated. Although ethio telecom started 4G LTE network service in main city areas in Addis Ababa, Ethiopia; subscribers are mainly using 3G network for Internet and data connection. Therefore the implementation part particularly focuses and works on the integration of 3G and Wi-Fi.

### 4.1 Cellular network monitoring

There are two ways to monitor cellular network system resources and congestions. The first one is proactively analyze network quality status, follow up performance thresholds and provide a solution to secure subscriber services. In the proactive approach different types of critical resources are monitored and when the resource usage become above a threshold level system congestion will occur. And immediate capacity expansions required such as adding resource license and cell redesign will take place [34]. Proactive approach method is very efficient way to handle issues before the problem reaches to subscribers and it is good practice to do in a daily basis.

The second method is reactive approach where appropriate actions will be taken after the problem or the issue happen. As an example the call block rate become higher than expected threshold value and because of that subscribers service quality affected. Using this approach it is very difficult to address the issue immediately and subscribers may be affected if actions are not taken on time.

### 4.2 Resource of 3G network

The following resources are mainly monitored in ethio telecom 3G network [34]

- Received Total Wideband Power (RTWP): total uplink power received by the base station.

- Transmitting Carrier Power (TCP): total downlink transmitting power of a cell. This measures the downlink load of a cell. The downlink capacity is limited by the base station amplifier capability.
- Orthogonal Variable Spreading Factor (OVSF): codes used by WCDMA as channelization codes. For one cell, only one OVSF code tree is available.
- Channel Element (CE): base station baseband processing resources. The CE is managed and shared on a NodeB level. Normally, a newly launched network will start with a very low CE configuration to save CAPEX. The CE would be the most likely resource that to run out first.
- Iub transmission resource: In IP RAN, the RNC and NodeB can dynamically adapt to the transmission network bandwidth. The Iub interface between the RNC and the NodeB will not become a bottleneck if the transmission capability of the interface boards is sufficient. Only the transmission network itself should be monitored from transmission network performance results.
- SPU: The RNC has several types of hardware boards. The Signaling Processing Unit (SPU) is the most likely bottleneck according to the configuration principles of the currently designed RNC. The SPU performs all air-interface signaling and all transmission resource management.

## 4.3 3G Resource usage metrics

Resource usages thresholds are defined in order to proactively monitor the resource status. In resource metric it is important to focus on busy hour time ranges. Busy hours can be an hour the resource usage is the highest of the day.

The main source of network congestion in 3G networks are TCP (transmission control power), CE (channel element), UL (uplink power) and code ratio. So we focus on these parameters. For the simulation purpose we choose most congested areas based on the above factors.

### 4.3.1 Uplink Load

In a CDMA network, the cell radio capacity is limited by the interference rise over the background noise. In this manner, the total interference (or total power) can be used to measure the cell

capacity. In a WCDMA system, the total power is defined as RTWP by base station. The system target load (maximum load considered normal) is 75%. The corresponding normal RTWP value should be below -100 dBm [34].

### **4.3.2 Downlink Load**

The total available transmit power from base station affects the downlink capacity of the 3G network. When the downlink load become congested the following parameters will be affected

- The cell coverage will be limited.
- The data throughput will be limited.
- The call quality will be degraded.
- New calls will be blocked

The total downlink power also affected by user location and cell size. The larger the cell size or the user far away it consumes more power. TCP is used to measure the downlink total transmitting power in WCDMA. The mean power measurement is used as the load indication. If the mean TCP is constantly higher than a threshold (such as 85%), it indicates that the cell downlink is overloaded [34].

### **4.3.3 Channel Element resource usage**

Channel Elements are one of the main resource in NodeB that to be properly planned and managed. A CE (channel Element) is a baseband resource in a NodeB. Different services have different requirement of CEs. One CE corresponds to the resource consumed by a 12.2 kbit/s voice call. If a new call is arrives but there is no enough CE to entertain the required resource the call will be dropped or blocked.

The total available CE resources are limited by both the installed hardware and the configured software licenses. If the hardware resources in the current installation are sufficient and the CEs are only limited by licenses, then the corrective action is to modify the license file to expand the cell capacity [34].

Monitoring CE resource carefully is very important using threshold level. It is recommended that if CE resource usage is above 70%, it means that the CE resource is congested and It is important to take actions accordingly immediately.

#### 4.3.4 OVSF code usage

Orthogonal Variable Spreading Factor (OVSF) are channelization codes used to separate data and control channels from same UE. In WCDMA network each channels are uniquely identified by codes. There are two types of codes used by WCDMA networks, these are scramble code and OVSF code. In the uplink, each user is allocated and identified by a unique scrambling code. In the downlink, the same scrambling code is used for users in the same cell, and users are identified by OVSF codes allocated to them. Each user is assigned a unique OVSF code. A threshold (such as 70%) can be defined for the DCH\_OVSF\_Utilization, to judge whether the system is overloaded.

When the OVSF resource is overloaded, capacity expansion procedures such as cell splitting or adding a new carrier are methods of corrective actions [34].

## 5.0 Simulation

### 5.1 Simulation Tool

Atoll simulation tools will be used to simulate both cellular and Wi-Fi network. It is known that Atoll is a 64-bit multi-technology wireless network design and optimization platform that supports wireless operators throughout the network lifecycle, from initial design to densification and Optimization. Atoll 3.2 includes integrated single RAN – multiple RAT network design capabilities for both 3GPP (GSM/UMTS/LTE) and 3GPP2 (CDMA/LTE) technology streams. It provides operators and vendors with a powerful native 64-bit framework for designing and optimizing current and future integrated multi-technology networks. Atoll 3.2 supports the latest technology advances such as HetNets and Wi-Fi offloading [35].

### 5.2 Planning and design

#### 5.2.1 Addis Ketema site Information

Currently most ethio telecom subscriber's uses 3G network as a primary data usage compared with 4G network, hence the simulation part focuses on the integration of 3G and Wi-Fi network. As we have seen above in the implementation consideration section, there are many reasons we say cellular network become congested. Data's from ethio telecom shows that there are many sites that are congested because of CE and TCP shortages. The following section shows collected data from ethio telecom about congested sites.

#### **Ethio telecom gathered data**

##### **1. What are the main call/data rejection/congestion Reason**

There are many reasons, but mainly uplink Received Total Wideband Power (RTWP), downlink TCP, CE and scramble code are source of network congestion.

##### **2. Congested Site**

There are many sites that are congested because of CE and TCP shortages, from these site we selected Addis-Ketema Merkato area where there a lot of business and trade transaction

takes places. Table 4 shows that 111053\_Addis Ketema site has resource usage with CE % level of 86.95% and TCP level of 98% which is above the threshold level.

Site name	Congestion Status
111053_Addis Ketema	CE % level: 86.95%
	TCP % level: 98 %

*Table 4 Addis Ketema Site information*

### **3. Digital MAP information**

Figure 16 shows 111053\_Addis Ketema site digital map information.

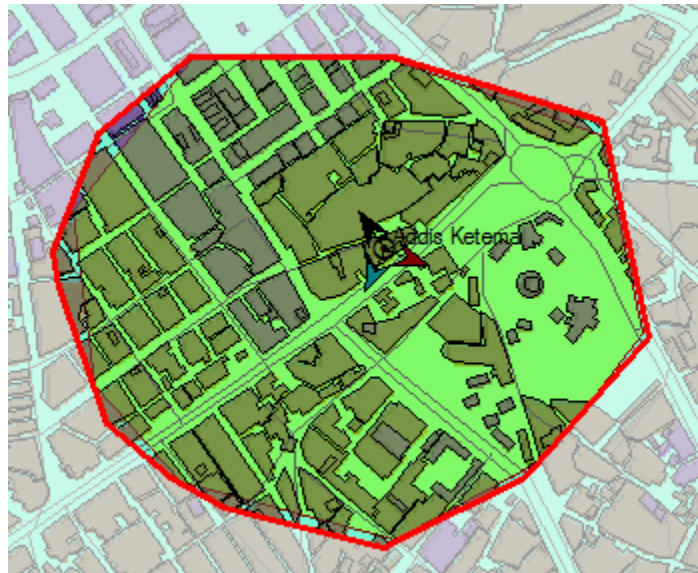

*Figure 16 111053\_Addis Ketema site map*

### **4. Area coverage of Cell radius**

It depends based on coverage of morphology. But when designed on average in Addis Ababa area 0.19KM is considered for cell radius.

### **5. Max number of users per Cell**

For the case of Addis Ababa city, a 3G network designed to serve a maximum of 224 people per cell or sector.

### **6. Max number of people in the congested circumstance per cell/transmitter**

For the case of 3G network it depends on the type of traffic profile of each user. It is difficult to say this is the maximum number of users that makes the network congested. As we have seen above there are different parameters that makes 3G network congestion. Normally the admission threshold for HSUPA and HSDPA is 10/64 user respectively. Even though we don't have admission control threshold for DCH user, 35-40 user can be considered as load margin for expansion.

## 7. Recommended rejected call% and data%

Out target is to maintain the rejection below 2-3 % for voice traffic and below 10% for data traffic.

### 5.2.2 Deployment Steps

1. The first step is to import digital map of Addis Ababa where the resolution of the maps that we use is 25 m. The map contains heights and altimetry and topographic relief of the Addis Ketema area. Some of Digital map information's are [37]

**Clutter** refers to a Land Use/Land Cover classification of surface features which impact on radio wave propagation. These features are classed according to their physical and electrical properties.

**Clutter altitude:** Digital Terrain Model (DTM) is a continuous model of ground-level land surface, represented by a digital raster grid with each grid cell holding an elevation value. A DTM is a fundamental data input for radio propagation studies in that terrain blocks and reflects radio waves.

**Clutter height:** the average building height on clutter.

2. Define Atoll Radio Parameters. Atoll radio parameters contains

#### Site information

Characterized by their X (longitude) and Y (Latitude) coordinates

#### Transmitter information

##### Transmitter

- Activity

- Antenna configuration (model, height, azimuth, mechanical/electrical tilts )
- UL/DL losses /UL noise figure
- Propagation (model , radius and resolution)

### Cell Parameter

- Frequency band and channel
- Layer
- Physical cell ID
- Power definition of DL channels
- Min. RSRP
- DL and UL traffic loads
- Diversity support (MIMO)
- Neighbors

The following table shows radio parameters for the selected sites

#### 1. Site parameter for 3G network

Name	Longitude	Latitude	Altitude (m)	Max No. of UL CEs	Max UP throughput Kbps	Max No. of DL CEs	Max DL throughput Kbps
111053_Addis Ketema	38.74158333	9.027638889	32	256	12,288	256	12,288

*Table 5 1 Site parameter for 3G network*

#### 2. Transmitter parameter for 3G network

There are three transmitter with each 3 cell/ sectors. Costa-Hata propagation model will be used both for 3G and WLAN network.

Site	Transmitter	Frequency	Antenna	Height(m)	Azimuth(°)	Mechanical Downtilt (°)	Receiver antenna diversity gain(dB)	Main Propagation Model
111053_Adis Ketema	111053_1	Band I	65deg 18dBi	32	325	2 degree	18	Costa-Hata model

Site	Transmitter	Frequency	Antenna	Height(m)	Azimuth(°)	Mechanical Downtilt (°)	Receiver antenna diversity gain(dB)	Main Propagation Model
			2Tilt210 0MHz					
111053_Adis Ketema	11105 3_2	Band II	65deg 18dBi 2Tilt210 0MHz	32	110	8 degree	18	Costa-Hata model
111053_Adis Ketema	11105 3_3	Band III	65deg 18dBi 2Tilt210 0MHz	32	205	6 degree	18	Costa-Hata model
111053_Adis Ketema	11105 3_4	Band I	65deg 18dBi 2Tilt210 0MHz	32	325	2 degree	18	Costa-Hata model
111053_Adis Ketema	11105 3_5	Band II	65deg 18dBi 2Tilt210 0MHz	32	110	8 degree	18	Costa-Hata model
111053_Adis Ketema	11105 3_6	Band III	65deg 18dBi 2Tilt210 0MHz	32	205	6 degree	18	Costa-Hata model
111053_Adis Ketema	11105 3_7	Band I	65deg 18dBi 2Tilt210 0MHz	32	325	2 degree	18	Costa-Hata model
111053_Adis Ketema	11105 3_8	Band II	65deg 18dBi 2Tilt210 0MHz	32	110	8 degree	18	Costa-Hata model
111053_Adis Ketema	11105 3_9	Band III	65deg 18dBi 2Tilt210 0MHz	32	205	2 degree	18	Costa-Hata model

Table 6 Transmitter parameter for 3G network

### 3. Cell parameters for 3G network

Cell ID	Transmitter ID
36601	111053_1
36602	111053_2
36603	111053_3
36604	111053_4
36605	111053_5
36606	111053_6
36607	111053_7
36608	111053_8
36609	111053_9

*Table 7 Cell parameters for 3G network*

### 4. Site parameter for Wi-Fi network

In the design phase it is assumed that a cell or sector is expected to handle maximum of 220 users. Hence for the case of 111053\_Addis Ketema site, since we have a nine cells it is expected the site serves a total of 1980 users. The thesis assumes that 20% of active users from a total 3G network subscribers. Out of 20% active 3G network users for this simulation purpose, we have offloaded 40% of users to Wi-Fi network, so the total number of users offloaded to Wi-Fi network is 159.

Therefore we need to calculate the number of Wi-Fi access points needed to cover the required users. As we have seen in the Wi-Fi design section, the maximum number of clients in a single AP is

$$\begin{aligned}\text{Number of client} &= \text{AP aggregate throughput} / \text{Minimum bandwidth per client} \\ &= 16.9/0.5 \\ &= 33.8 \text{ users per AP}\end{aligned}$$

$$\begin{aligned}\text{Total Number of Aps} &= \text{Total number of active user} / \text{Number of client per AP} \\ &= 159/33.8 \\ &= 5 \text{ APs}\end{aligned}$$

Therefore from Capacity perspective minimum 5 APs is required to cover the 159 users with minimum 500kbps throughput traffic usage. The following table summarizes site parameter for Wi-Fi network.

Name	Longitude	Latitude
Site0	"38°44'22.97""E"	"9°1'42.82""N"
Site1	"38°44'21.66""E"	"9°1'35.66""N"
Site2	"38°44'29.56""E"	"9°1'33.25""N"
Site3	"38°44'34.6""E"	"9°1'38.43""N"
Site4	"38°44'27.92""E"	"9°1'40.22""N"

Table 8 Wi-Fi site parameter

## 5. Transmitter parameter for Wi-Fi network

For our simulation purpose we use Omni directionally antenna with Costa-Hata propagation model.

Site	Transmitter	Antenna	Height (m)	Main Propagation Model
Site0	Site0_1	2450MHz Omni 5.8dBi	22	Costa-Hata model
Site1	Site1_1	2450MHz Omni 5.8dBi	22	Costa-Hata model
Site2	Site2_1	2450MHz Omni 5.8dBi	22	Costa-Hata model
Site3	Site3_1	2450MHz Omni 5.8dBi	22	Costa-Hata model
Site4	Site4_1	2450MHz Omni 5.8dBi	22	Costa-Hata model

Table 9 Wi-Fi Transmitter parameter

### 5.2.3 Traffic parameters

A user equipment (UE) profile describes the terminal equipment type, traffic type, and mobility characteristics which is defined in the UE Profile. UE profile has to be defined before starting the simulation. The following section describes UE profiles used for our simulation.

#### Service

It is expected that in each site, users generate different 3G traffics. This research considers only voice, Mobile Internet, Internet service and high-speed Internet service for traffic modeling and uses Atoll default values for simulation purpose.

#### Service for 3G

Name	Average throughput UL	Average throughput DL
High Speed Internet	32 kbps	256 kbps
Mobile Internet	32 kbps	64kbps
voice	12.2 kbps	12,2 kbps

*Table 10 3G user server profile*

#### Service for Wi-Fi

Name	Average throughput UL	Average throughput DL
High Speed Internet	64 kbps	500 kbps
Internet service	64 kbps	128 kbps

*Table 11 Wi-Fi user server profile*

#### Mobility

The thesis mainly focuses on dense urban areas, hence it is not expected that users will travel at high speed, therefore we considers only pedestrian and max 50 km/h speed.

## Terminal

From atoll default terminal device types the paper considers HSPA and Mobile Terminal device, and also it is expected that most of the traffic will be created by mobile terminal devices and high throughput traffic will be created by HSPA terminal.

Name	Min Power	Max Power
HSPA terminal	-50dBm	24dBm
Mobile terminal	-50dBm	25dBm
Wi-Fi terminal	-50dBm	25dBm

*Table 12 Terminal profile*

## Environment

There are different environment models, but for this thesis we will consider only dense urban area only. At the stage of the design it is expected that hexagonal cells, with 190 m cell radius will be used for 3G network

User profile	Mobile	percent
user	pedestrian	80
user	50Km/hour	20

*Table 13 Environment profile*

## User profile by service

### User profile for 3G

Service	Terminal	Call/hour	Call duration(sec)	UL Volume(KB)	DL Volume(KB)
Mobile Internet Access	HSPA	0.1		500	2,500

Service	Terminal	Call/hour	Call duration(sec)	UL Volume(KB)	DL Volume(KB)
High Speed Internet	HSPA	0.05		2,000	10,000
Voice	Mobile	0.2	240		

Table 14 User profile for 3G

### User profile for Wi-Fi

User Profile	Service	Terminal	Calls/hour	Duration (sec.)	UL Volume (KBytes)	DL Volume (KBytes)
Business User	High Speed Internet	802.11n Terminal	0.01		2,000	10,000
Business User	Web Browsing	802.11n Terminal	0.1		700	4,500

Table 15 User profile for 3G

### 5.2.4 Propagation model

There are different propagation models to model wireless network. Costa-Hata model is best for frequency range above 1500 MHz, Therefore Costa-Hata will be used for both 3G and Wi-Fi network.

The default prediction resolution of atoll is 50m, so to make the result more accurate 20m resolution will be used.

### Monte-Carlo Simulation

We use atoll Monte Carlo simulator for both 3G and Wi-Fi simulations. Since the user distributions of traffic map Atoll generates a population of users on the map and for each of these users the simulator executes a power control algorithm for the uplink and downlink. The objective of the algorithm is to minimize interference and maximize network capacity. This will restrict the connection to the network users who use low-priority services and generate a lot of interference. This process creates a snapshot of the UMTS network, the result is a distribution of users with different network parameters: level of interference, the terminal state (connected, connection refused ...), load factor for each cell, etc [37].

### 5.2.5 Deployment target

After we modeled the traffic of Addis Ababa city, it is possible to start the simulation to meet the target quality objective. The simulation is expected to meet the following target level.

Service	Service Probability of service rejection
Voice	2-3 %
Internet service	10%
High speed Internet service	10%

*Table 16 deployment target*

### 5.2.6 Simulation Steps

As we have seen above Atoll simulations are based on a Monte Carlo simulator and we use both for UMTS and Wi-Fi network.

In UMTS each mobile station receives interference from base stations other than their own cells, but not other phones, and all base station receives interference from their cell phones and other cells, but not the other base stations [37].

The UMTS capacity depends on the total received interference. Atoll simulates the power control mechanism using an iterative algorithm in each iteration, all the population of mobile users generated try to be connected, one by one, to the network.

The simulation assumes that there will be a total of 220 people density with in a cell per a single carrier. Since we have a total of 9 carrier, the total number of people is 1980. Additionally the simulation considers that 20% of a total number population which is 396 people is actively participate both in the data and voice connection.

The following table shows user distribution per service

Number of People	Type of Service	Percentage
40	High speed Internet	10%
119	Mobile Internet	30%
237	Voice	60%

*Table 17 user distribution per service*

## 6.0 Result

The following section shows simulation results for both 3G and Wi-Fi network for 111053\_Addis Ketema site. The result first shows 3G network coverage and capacity analysis before offloading and then after Wi-Fi offloading.

### 6.1 3G Network before Wi-Fi offloading

In this section we simulate all users connecting to 3G UMTS network only. We see coverage signal level, coverage area and its quality of service from users' perspective for different services.

#### 6.1.1 Study coverage signal level

Converge by signal level shows graphical representation of the signal level received by the terminal or downlink coverage. Figure 17 shows coverage signal level for 3G network. The figure shows that centrally we have good signal level coverage of  $>-80$  dBm. Additionally over the entire target area it is shown that a good signal coverage of  $\geq -90$  dBm. Since our mobile terminal typical sensitivity is  $-105$  dBm, the overall signal level coverage shown in the figure is good.

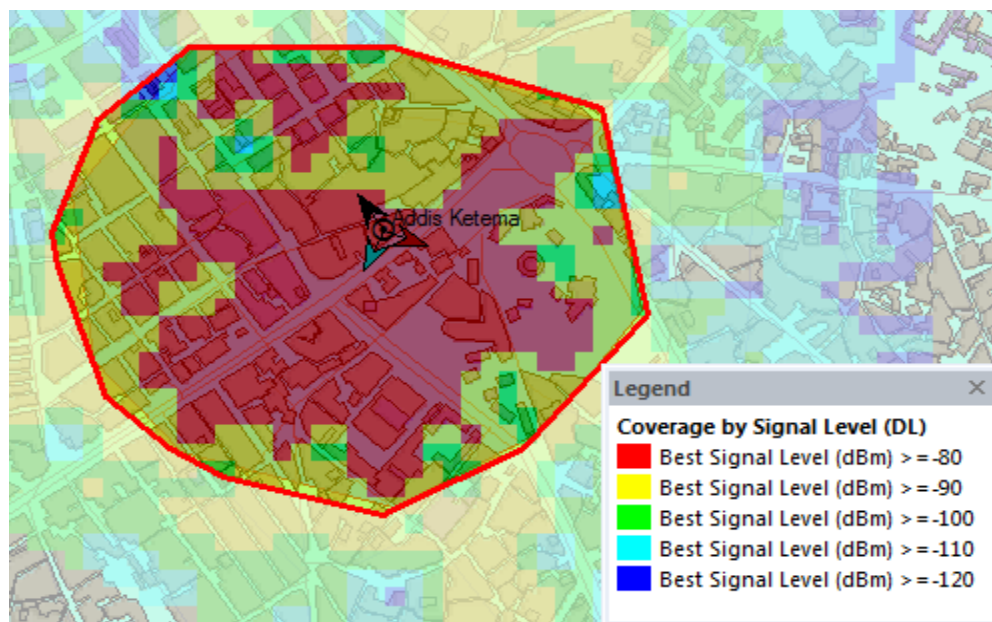

Figure 17 Study level of signal coverage

## 6.1.2 Study transmitter coverage

Transmitter coverage shows each transmitter coverage with in target area. Figure 18 shows that all three transmitters' coverage using different color and shows that signal coverage have good coverage with in computational zone.

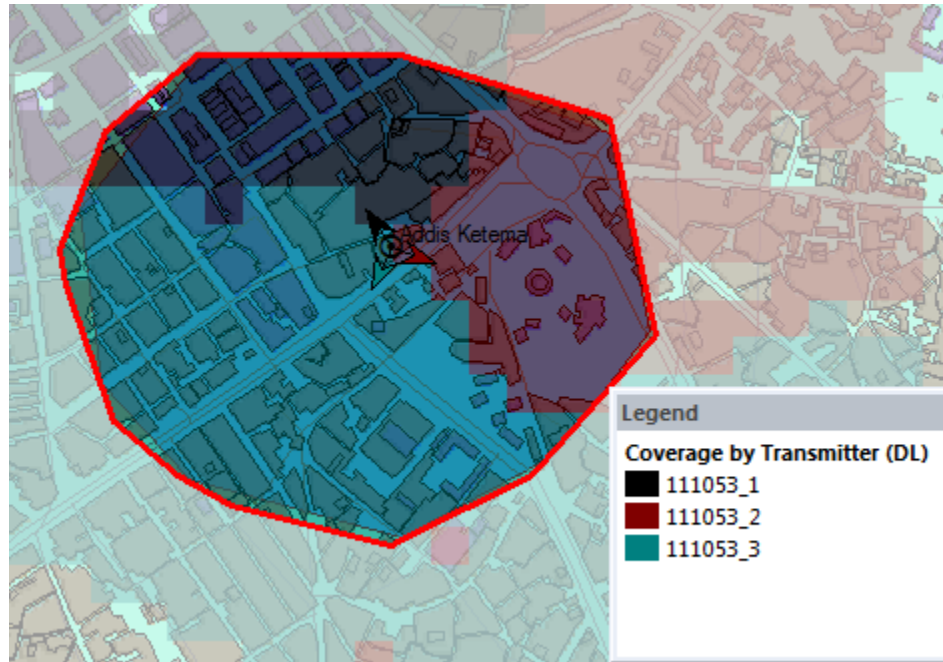

Figure 18 Study transmitter coverage

## 6.1.3 3G Capacity analysis

The following section shows 3G users' connection for different services accepted by UE terminal. The simulation is based on Monte Carlo simulator, where Using Monte Carlo simulator a user connects randomly to one of 3G services. The UE is capable of accessing all 3G network for high speed Internet, mobile Internet and voice traffic.

### 6.1.3.1 3G network capacity Before Wi-Fi offload

This section shows the actual 3G network capacity analysis simulation result for Addis Ketema area before Wi-Fi network offload. Table 18 shows that out of 381 total user 175 or 45.9% become rejected. The table shows that there are many reasons a user become rejected. But mainly channel element (CE) and Downlink load saturation are the main reasons.

Total number of rejected users: 175 (45.9%)	
Pmob > PmobMax:	16
Ptch > PtchMax:	0
Ec/Io < (Ec/Io) min:	5
UL Load Saturation:	0
Ch. Elts saturation:	111
DL Load Saturation:	41
OVSF Code Saturation:	2

Table 18 3G network capacity analysis

Further Figure 19 shows in detail users 3G service connection at the time of simulation where trying to access 3G network for high speed Internet, mobile Internet and voice services.

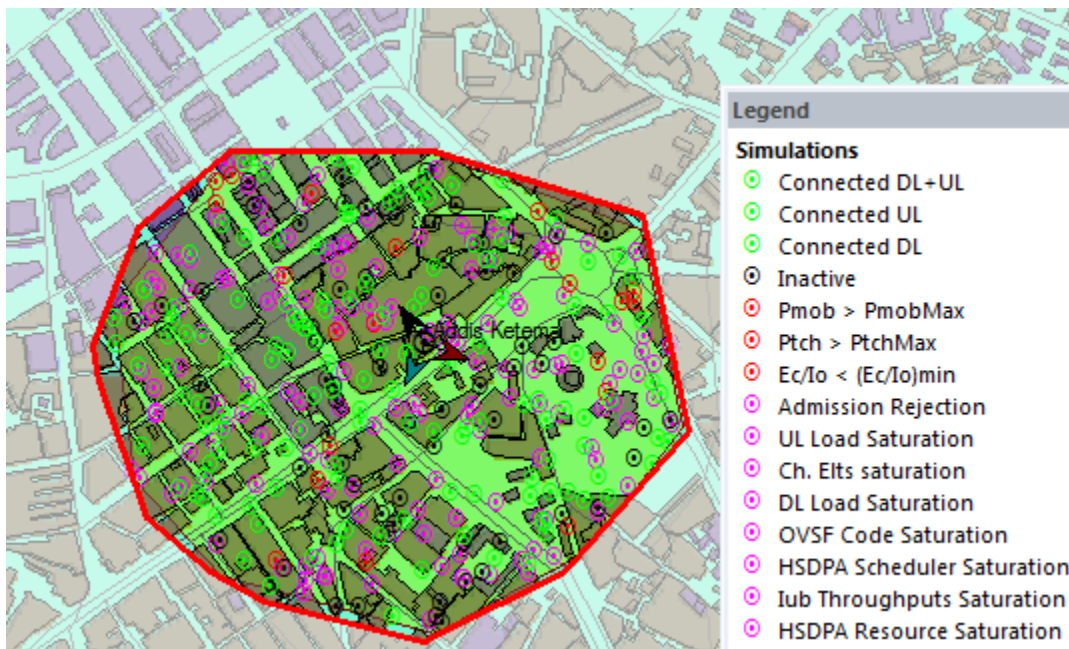

Figure 19 3G Capacity Result before Offloading

### 6.1.3.2 3G user connection by Service

In this section we see 3G network simulation results by different services. Out of a total 381 users there are 77 inactive users

Users: 381

Active: Downlink: 79 Uplink: 100 Downlink + Uplink: 125

Inactive: 77

Throughput: Downlink: 37.23 Mbps Uplink: 9.53 Mbps

### **Breakdown per service:**

#### **High Speed Internet:**

Users: 119

Active: Downlink: 23 Uplink: 25 Downlink + Uplink: 65

Inactive: 6

Throughput: Downlink: 33.79 Mbps Uplink: 5.76 Mbps

#### **Mobile Internet Access:**

Users: 53

Active: Downlink: 8 Uplink: 10 Downlink + Uplink: 31

Inactive: 4

Throughput: Downlink: 2.5 Mbps Uplink: 2.62 Mbps

#### **Voice:**

Users: 209

Active: Downlink: 48 Uplink: 65 Downlink + Uplink: 29

Inactive: 67

Throughput: Downlink: 939.4 kbps Uplink: 1.15 Mbps

### **6.1.4 Result Analysis before Wi-Fi offloading**

The simulation results are far from the target grade of service objectives which is 2-3% for voice and 10% for Internet services. More users are rejected because of channel element (CE) shortage and downlink (DL) power saturation which is the actual ethio telecom current problem for the case of 3G network. As users request web browsing and high speed Internet service, which is higher data rate services, more channels elements required and additionally it requires more downlink power in order to cover the request services.

Therefore without Wi-Fi offloading, ethio telecom has to do the following measurements in order to solve the above issue

1. For the shortage of Channel Element (CE):
  - a. Channel element is Software licensed capacity resource which is required for traffic channel. So if ethio telecom has remaining CE license, it can be upgraded to meet the requested traffic.
  - b. If the upgraded software license is not enough to cover the requested traffic channel, it is required to add new carrier
2. For the DL power shortage: It is required to add more transmitters in order to distribute more power for the requested traffic. This provide us additional benefit to improve the signal quality and improve the carrier interference pilot channel (DL) threshold level ( $E_c / I_o < E_c / I_{or\ min}$ ).

## 6.2 UMTS coverage After Wi-Fi offloading

The UMTS coverage after Wi-Fi offloading considers 42% of 3G network users offloaded to Wi-Fi network, which is the remaining 222 user's statistics. As we can see from figure 20, the total number of rejected user is 2.7%, which meets the target value.

**Total number of rejected users: 6 (2.7%)**

Figure 20 shows the result in detail that the total number of rejected users is reduced to 2.7%. This provides higher satisfaction to the mobile users and reduces ethio telecom cellular network burden.

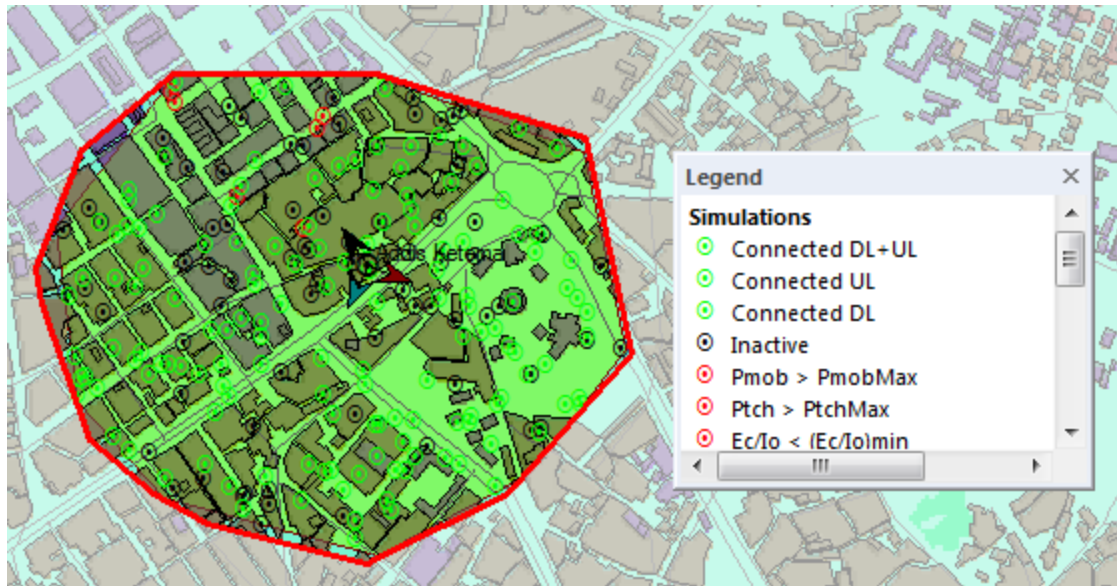

Figure 20 3G network simulation after Wi-Fi offloading

### 6.3 UMTS and Wi-Fi network integration

In this section we see cumulative result of 3G and Wi-Fi network. In the simulation part we see the whole coverage and capacity status together. Figure 21 shows traffic statistics that are offloaded to Wi-Fi network only. Out of 159 users, 91.8 % of users become successfully connected to Wi-Fi network and get the required services from Wi-Fi, which meets the design objective for data traffic. The simulation uses IEEE 802.11n protocol which provides higher data rate service compared with older IEEE 802.11a and IEEE 802.11b version. Other Wi-Fi protocols like 802.11ac provides more data rate compared with all other protocols. But since currently most smart phones doesn't support IEEE 802.11ac protocol we used IEEE 802.11n protocol for the simulation purpose.

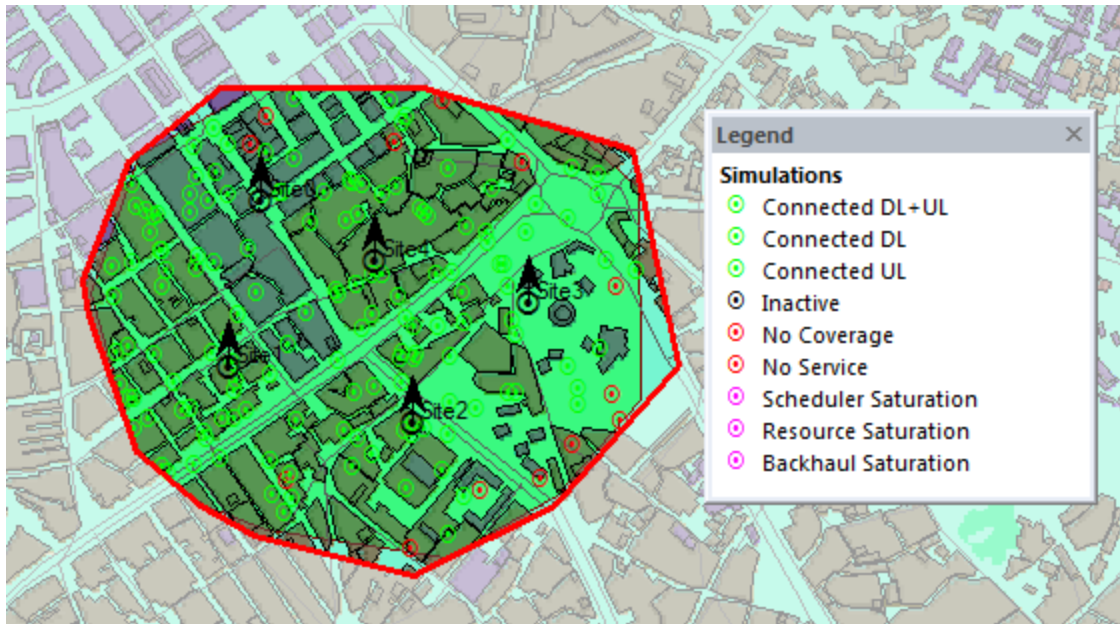

Figure 21 Cumulative Cellular and Wi-Fi network status

The following section shows Wi-Fi user connections by different services. All users are active and can access web browsing and high speed Internet. And from a total of 159 users only 8.9% are rejected, which meets deployment target.

### 6.3.1 Users Demand

#### Total number of users trying to connect

The following result shows summarized traffic demand for 159 users. All users have both downlink and uplink demand with 49.74Mbps and 15.23Mbps throughput respectively.

Users: 159

Active: Downlink: 0 Uplink: 0 Downlink + Uplink: 159

Inactive: 0

DL: Max Throughput Demand (DL): 49.74 Mbps

Min Throughput Demand (DL): 0 bps

UL: Max Throughput Demand (UL): 15.23 Mbps

Min Throughput Demand (UL): 0 bps

### **Breakdown per service:**

The following section shows users traffic demand per services.

#### **High Speed Internet:**

There are 79 high speed Internet users that demand both downlink and uplink data with 39.5Mbps and 10.11Mbps throughput.

Users: 79

Active: Downlink: 0 Uplink: 0 Downlink + Uplink: 79

Inactive: 0

DL: Max Throughput Demand (DL): 39.5 Mbps

Min Throughput Demand (DL): 0 bps

UL: Max Throughput Demand (UL): 10.11 Mbps

Min Throughput Demand (UL): 0 bps

#### **Web Browsing:**

There are 80 high speed Internet users that demand both downlink and uplink data with 10.24Mbps and 5.12Mbps throughput.

Users: 80

Active: Downlink: 0 Uplink: 0 Downlink + Uplink: 80

Inactive: 0

DL: Max Throughput Demand (DL): 10.24 Mbps

Min Throughput Demand (DL): 0 bps

UL: Max Throughput Demand (UL): 5.12 Mbps

Min Throughput Demand (UL): 0 bps

### **6.3.2 Result**

The result shows that out of 159 users only 13 or 8.2% of users are not connected to Wi-Fi network because of no signal coverage and no service on that area. The rest 146 users are effectively get the requested uplink and downlink traffic request. The result meets designed objective for data traffic.

**Total number of users not connected (rejected): 13 (8.2%)**

No Coverage:	1
No Service:	12

## **7.0 Conclusion and future works**

The thesis work is mainly focuses on offloading cellular network in to complementary Wi-Fi network to reduce cellular network congestion. As the main intention of the paper is to recommend

ethio telecom to look alternative way to solve the current cellular congestions, we see in the simulation part that after offloading 42% of 3G network to Wi-Fi network, the number of rejected users reduced from 45.9% to 2.3% for voice and 8.2% for data users. Additionally the simulation result shows that, data traffic is the main source of cellular network congestion. And offloading data traffic to Wi-Fi network benefits ethio telecom by reducing the burden of cellular network and insures that subscribers are satisfied by both voice and data service.

Starting from 3GPP release 6 the integration of cellular and Wi-Fi network shows more improvement and user equipment's (UE) can connect both 3G and Wi-Fi network simultaneously and can seamlessly transition data traffics with or without user's interactions.

Wi-Fi is an inexpensive technology compared with other wireless technology which provides higher data rate services. Since Wi-Fi technology is integrated to every smart phone and laptop devices, it easy to integrate with cellular network and can use SIM based authentication and secure the traffic using IPsec tunnel. Without Wi-Fi offloading ethio telecom has to plan additional separate carrier to meet the subscriber's request.

The integration of cellular and Wi-Fi network is new concept for ethio telecom and its subscribers. Additional works have to done on the market interest, from legal perspectives and price perspective.

## Reference

1. Cisco visual networking index: Global Mobile Data Traffic Forecast Update, 2016-2021, February 2017.  
*<https://www.cisco.com/c/en/us/solutions/collateral/service-provider/visual-networking-index-vni/mobile-white-paper-c11-520862.pdf>*
2. Desktop vs Mobile vs Tablet Market Share Ethiopia, January, 2017.  
*<http://gs.statcounter.com/platform-market-share/desktop-mobile-tablet/Ethiopia>*
3. Md. Alimul Haque, Pritam Kumar, Amrendra Kumar Singh, “IEEE 802.11ac: 5th Generation WiFi Networking” World Applied Programming, Vol (2), No (4), April 2012.
4. Janice Reynolds “Going Wi-Fi-A Practical Guide to Planning and Building an 802.11 Network”, 2003
5. Cisco Systems, Inc. Building Cisco Multilayer Switched Networks, Volume 2 Version 3.0, 2006
6. Albert K. Ansah *q*, IAENG, T.Kwantwi, and Agangiba W.Akotam “Comparing Wireless N (IEEE 802.11n) and Wireless G (IEEE 802.11g) Standards in terms of Performance and Reliability”, July 2011
7. Sourangsu Banerji, Rahul Singha Chowdhry “On IEEE 802.11: Wireless LAN Technology” 2013
8. Research in Motion Limited, “Considerations for Planning and Deploying a Wireless LAN, Technical White Paper”, 295 Phillip Street Waterloo, ON N2L 3W8 Canada, 2010
9. ETSI Mobile Competence Centre “Overview of 3GPP Release 6 Summary of all Release 6 Features Version TSG #33”, 2006
10. 3GPP TR 22.934 V6.2.0 “Feasibility study on 3GPP system to Wireless Local Area Network (WLAN) interworking (Release 6)”, Sep. 2009.
11. Tatiana Issaeva, 3G – WLAN Systems Interworking Architecture, February 2017.  
*[http://www.tcs.hut.fi/Studies/T79.5401/2005AUT/3G\\_WLAN\\_Interworking.pdf](http://www.tcs.hut.fi/Studies/T79.5401/2005AUT/3G_WLAN_Interworking.pdf)*
12. 3GPP TS 33.234 V6.9.0, “3G Security; Wireless Local Area Network (WLAN) interworking security (Release 6)”Mar. 2007

13. A.S.Rumale, Dr.D.N.Chaudhari, IEEE 802.11x, and WEP, EAP,WPA/WPA2, International Journal of Computer Technology and Appli-cations,pp. 2229-6093 Vol.2(6) Nov-Dec 2011.
14. IETF RFC 3748 – Extensible Authentication Protocol (EAP), 2004
15. Rajavelsamy, Manoj Choudhary and Debabrata Das “A Review on Evolution of 3GPP Systems Interworking with WLAN” 19 March 2016.
16. 3GPP TS 23.402 V8.10.0 “Architecture enhancements for non-3GPP accesses (Release 8)” Mar 2012
17. 3GPP TS 22.278, “Service requirements for the Evolved Service requirements for the Evolved Packet System (EPS) (Release 8)” 2009.
18. A. Schumacher / J. Schlien “WLAN Traffic Offload in LTE”, White Paper Nov. 2012
19. Warda Ahmed, Sidra Anwar and M. Junaid Arshad “Security Architecture of 3GPP LTE and LTE-A Network: A Review”
20. IETF RFC 5213: Network Working Group, “Proxy Mobile IPv6”, August 2008.
21. ETSI MCC, “Overview of 3GPP Release 9 V0.3.” 2014
22. ETSI MCC, “Overview of 3GPP Release 10 V0.2” Jun 2014
23. 3GPP TS 23.402 “3rd Generation Partnership Project; Technical Specification Group Services and System Aspects; Architecture enhancements for non-3GPP accesses (Release 10)” 2011
24. 3GPP TS 23.139 “3GPP System-Fixed Broadband Access Network Interworking stage 2 (Release 11)
25. QUALCOMM Incorporated, “A 3G/LTE Wi-Fi Offload Framework: Connectivity Engine (CnE) to Manage Inter-System Radio Connections and Applications” Jun. 2011.
26. ETSI MCC, “Overview of 3GPP Release 12 V0.2” 2015.
27. Mobile Data Offload- Wi-Fi Offload – TEC, February 2017.  
*<http://tec.gov.in/pdf/Studypaper/Mobile%20data%20offload.pdf>*
28. Nadeem Akhtar, “LTE-WLAN Interworking: 3GPP Release-12 Perspective” IEEE standards workshop on last mile Connectivity”, Bangalore, India, July. 2013.
29. ETSI MCC, “Release 13 analytical view version “, Sept. 2015.
30. Richard Burbidge, 3GPP RAN2 WG chair “LTE-WLAN Aggregation (LWA) and LTE WLAN Radio Level Integration with IPsec Tunnel (LWIP)”, IEEE meeting in Macao, March 13-18 2016.
31. Intel Corporation, “Alternative LTE Solutions in Unlicensed Spectrum: Overview of LWA, LTE-LAA and beyond”, whitepaper, 2016

32. 5G America, “Mobile Broadband Evolution towards 5G: Rel-12 & Rel-13 and Beyond” Feb. 2017.
33. Ruckus Wireless, Inc “Deploying Very High Density Wi-Fi DESIGN AND CONFIGURATION GUIDE FOR STADIUMS”, Best Practices v1.0, 2012.
34. HUAWEI TECHNOLOGIES CO., LTD, “UMTS RAN13.0 Capacity Monitoring Guideline”, Draft A, Feb. 2011.
35. Forsk, “Atoll wireless network engineering group version 3.2 brochure”, February 2013
36. Forsk, “LTE Radio Network Design Tool – Atoll”
37. <https://www.slideshare.net/mobile/kaboudei/rf-planning-umts-with-atoll1>, February, 2017)
38. Sapna Shukla, Varsha Khare, Shubhanshi Garg, Paramanand Sharma, “Comparative Study of 1G, 2G, 3G and 4G” April 2013
39. Jyotsna Agrawal, Rakesh Patel, Dr. P.Mor, Dr. P.Dubey and Dr. J.M.keller, “Evolution of Mobile Communication Network: from 1G to 4G” Nov 2015
40. Martyn Mallick, “Mobile and Wireless Design Essentials” 2003
41. Rysavy Research/4G Americas “Mobile Broadband Explosion”, August 2013
42. Aerohive Networks “High-Density Wi-Fi Design Principles” 2012
43. Mobile Broadband VPN service, March, 2017  
*<http://www.ethionet.et/node/580396?q=mobilebroadbandvpn>*
44. Ramia Babiker Mohammed Abdelrahman, Amin Babiker A. Mustafa, Ashraf A. Osman “A Comparison between IEEE 802.11a, b, g and ac Standards” 2015
45. Rebecchi, F., De Amorim, M. D., Conan, V., Passarella, A., Bruno, R., & Conti, M. (2015). Data offloading techniques in cellular networks: A survey. *IEEE Communications Surveys and Tutorials*, 17(2), 580–603.
46. Beneyam H., Haile B., Edward Mutafungwa and Warma, “Development of the Wi-Fi Offloading Business Concept within the African Market Context”, 2012.
47. R. Rajavelsamy, M. Choudhary, and D. Das, “A Review on Evolution of 3GPP Systems Interworking with WLAN,” *Journal of ICT Standardization*, vol. 3, no. 2, pp. 133–156, 2015.
48. A. Aijaz, N. Uddin, O. Holland, and A. H. Aghvami, “On Practical Aspects of Mobile Data Offloading to Wi-Fi Networks,” Ithaca, NY, USA, 2015.