



ADDIS ABABA UNIVERSITY  
SCHOOL OF GRADUATE STUDIED  
FACULTY OF TECHNOLOGY  
DEPARTMENT OF MECHANICAL ENGINEERING

**Modeling and Simulation of Facility for a System  
Subjected to Dynamic Demand Constraint**

*(A Case Study on Anbessa City Bus Service Enterprise)*

A thesis submitted to Graduate Studies of Addis Ababa  
University in partial fulfillment of the requirements for Degree  
of Master of Science in Mechanical Engineering(Industrial  
Engineering)

By Bisrat Engidawork

Advisor Dr. Subhash Chandra

June , 2008

**Modeling and Simulation of Facility for a  
System Subjected to Dynamic Demand  
Constraint**

*(A Case Study on Anbessa City Bus Service Enterprise)*

By Bisrat Engidawork

Approved By Board of Examiners:

\_\_\_\_\_  
Chairman Department of Graduate Committee

\_\_\_\_\_  
Dr. Subhash Chandra

Advisor

\_\_\_\_\_  
Internal Examiner

\_\_\_\_\_  
External Examiner

## **Acknowledgment**

First for most I would like to thank God for the courage he has given me to complete this thesis work. I also would like to express my deep gratitude to my families for their full support and encouragement throughout this study. I am grateful to my advisor Dr. Subhash Chandra for his full support to make this study fruitfully. I also thanks Ato Girum Bisrat the Unit Rebuild and Engineering division manger and Ato Muhie Awel Yeka depot maintenance head of the Anbessa City Bus Service Enterprise for their genuine cooperation. At last my special thanks goes to my friends for their important advice and recommendations.

## **Abstract**

Facility layout designs are one of the major studies in manufacturing engineering. This thesis work involves the dynamic analysis of material flow in the facility layout design with the help of simulation. The study is conducted taking the case of Anbessa City Bus Service Enterprise Yeka Depot maintenance facility.

The study was done by first reviewing literature in the areas of facility layout design and simulation. Then the operation and maintenance services of the Yeka Maintenance Facility was analyzed by collecting the required data.

The stochastic model of the facility was developed with the help of Arena Simulation package. To evaluate the performance the model is simulated for one months period of time with four replication and the result observed. After analyzing the result of the simulation different scenarios are developed to see the possible improvements with appropriate modifications. At last conclusion and recommendation is forwarded based on the ongoing analysis.

## List of figures

<i>Figure 2-1 Systematic Layout Planning (SLP)</i> .....	11
<i>Figure 3-1 Resource Status</i> .....	26
<i>Figure 3-2 System Types</i> .....	27
<i>Figure 3-3 Distribution fittings</i> .....	30
<i>Figure 3-4 Basic Simulation steps</i> .....	36
<i>Figure 3-5 Arena Simulation Environment</i> .....	39
<i>Figure 5-1. ACBSE Maintenance Organization</i> .....	46
<i>Figure 5-2 Maintenance work flow</i> .....	48
<i>Figure 6-1 Yeka Depot Facility Layout</i> .....	51
<i>Figure 7-1 Maintenance Model Logic</i> .....	55
<i>Figure 7-2 Process data Entry Window</i> .....	56
<i>Figure 7-3 Model logic</i> .....	58
<i>Figure 7-4 Depot maintenance sub model</i> .....	59
<i>Figure 7-5 Corrective maintenance sub model</i> .....	61
<i>Figure 7-6 Garage sub model</i> .....	63
<i>Figure 7-7 Animation Window</i> .....	64
<i>Figure 7-8 Simulation Setup</i> .....	65
<i>Figure 8-1 Animation of the facility</i> .....	66
<i>Figure 9-1 Modified layout</i> .....	76

## List of Tables

<i>Table 6-1 Workers in Technical department .....</i>	<i>50</i>
<i>Table 6-2 Maintenance Service Distributions .....</i>	<i>53</i>
<i>Table 7-1 Garage maintenance shops constitution .....</i>	<i>62</i>
<i>Table 8-1 Cycle time for the existing facility.....</i>	<i>67</i>
<i>Table 8-2 Waiting time &amp; length .....</i>	<i>67</i>
<i>Table 8-3 Number of bus maintained in one month.....</i>	<i>68</i>
<i>Table 8-4 Location Utilization .....</i>	<i>69</i>
<i>Table 9-1 Results of Scenario 1 for one month.....</i>	<i>71</i>
<i>Table 9-2 Net savings from Adding employee .....</i>	<i>71</i>
<i>Table 9-3 Major Spare part costs .....</i>	<i>72</i>
<i>Table 9-4 Results of scenario 2 for one month.....</i>	<i>74</i>
<i>Table 9-5 Result of scenario -3 .....</i>	<i>76</i>

## *Table of Contents*

Acknowledgement.....	i
Abstract.....	ii
<b>PART ONE – INTRODUCTION</b>	
1 INTRODUCTION .....	1
1.1 BACKGROUND .....	1
1.2 PROBLEM STATEMENT .....	2
1.3 OBJECTIVES OF THE STUDY.....	3
1.4 METHODOLOGY.....	4
<b>PART TWO- LITERATURE REVIEW</b>	
2 FACILITY LAYOUT.....	5
2.1 DEFINITIONS.....	5
2.2 THE NEED & BENEFITS OF EFFICIENT LAYOUT .....	6
2.3 CLASSES OF PLANT LAYOUT PROBLEMS.....	7
2.4 OBJECTIVES OF PLANT LAYOUT DESIGN .....	9
2.5 LAYOUT DESIGN PROCEDURES .....	10
2.5.1 SYSTEMATIC LAYOUT PLANNING .....	10
2.5.2 APPROACHES FOR FACILITY LAYOUT PROBLEM.....	12
2.6 PERFORMANCE EVALUATIONS OF FACILITY LAYOUT .....	13
2.7 COMPUTERIZED LAYOUT PLANNING.....	15
2.7.1 COMPUTERIZED LAYOUT GENERATION.....	15
2.7.2 FACILITY LAYOUT PLANNING TOOLS .....	16
2.8 PLANT LAYOUT SIMULATION .....	17
2.9 BENEFITS OF PLANT LAYOUT SIMULATION.....	18
3 SIMULATION .....	19
3.1 DEFINITION.....	19
3.2 THE NEED OF SIMULATION .....	20
3.3 BENEFITS OF SIMULATION .....	22

3.4	BASIC SIMULATION COMPONENTS.....	24
3.4.1	ENTITIES .....	25
3.4.2	ENTITY ATTRIBUTES.....	25
3.4.3	QUEUES.....	25
3.4.4	RESOURCES.....	26
3.5	SYSTEM CLASSIFICATIONS .....	27
3.5.1	SYSTEM TYPES.....	27
3.6	SIMULATION MODELS.....	29
3.7	SIMULATION TYPES.....	30
3.8	DATA COLLECTION & ANALYSIS.....	30
3.8.1	SOURCES FOR INPUT DATA.....	31
3.8.2	DATA TYPE.....	31
3.8.3	INPUT PROBABILITY DISTRIBUTIONS .....	32
3.8.4	DISTRIBUTION FITTING CHECKS.....	33
3.9	STEPS IN SIMULATION STUDY. ....	36
3.10	ARENA SIMULATION ENVIRONMENT .....	37
4	QUEUING THEORY .....	40
4.1	BASIC CHARACTERISTICS OF QUEUING SYSTEM.....	41
4.1.1	THE INPUT OR ARRIVAL PATTERN OF CUSTOMERS.....	41
4.1.2	THE PATTERN OF SERVICE.....	41
4.1.3	THE NUMBER OF SERVERS .....	42
4.1.4	THE CAPACITY OF THE SYSTEM .....	42
4.1.5	THE QUEUE DISCIPLINE.....	42

## **PART THREE CASE STUDY PRESENTATION**

5	OVERVIEW OF THE COMPANY.....	44
5.1	COMPANY PROFILE.....	44
5.2	ANBESSA MAINTENANCE FACILITY ORGANIZATION .....	45
5.3	MAINTENANCE WORK FLOW .....	48
6	DATA COLLECTION & ANALYSIS.....	49
6.1	FACILITY CAPACITY.....	49
6.2	BUS ARRIVAL PATTERN .....	51

6.3	SERVICE TIME.....	52
6.4	DISTRIBUTION FITTING .....	53
7	SIMULATION MODEL DEVELOPMENT.....	54
7.1	MODEL FORMULATION .....	54
7.2	MODEL DESCRIPTION .....	57
7.3	SIMULATION SETUP .....	64
8	SIMULATION RESULT .....	66
8.1	CYCLE TIME.....	66
8.2	WAITING TIME & LENGTH .....	67
8.3	TOTAL BUS MAINTAINED IN EACH SHOP.....	68
8.4	LOCATION UTILIZATION .....	69
9	DEVELOPING SCENARIOS .....	70
9.1	SCENARIO 1 –ADDING NEW EMPLOYEES.....	70
9.1.1	ADVANTAGES .....	71
9.1.2	COST .....	71
9.2	SENARIO2 -WITHOUT SPARE PART PROBLEM.....	72
9.2.1	ADVANTAGES .....	73
9.2.2	COST .....	74
9.3	SCENARIO 3- WITH REARRANGED LAYOUT.....	75
10	CONCLUSION.....	77
11	RECOMMENDATIONS.....	78
	REFERENCES .....	79

# **1 Part one Introduction**

## **1.1 Background**

In the era of rising global competition industries must thrive to utilize their resources effectively and efficiently to sustain their market position and guarantee their future existence. In developing countries where scarce resources and limited technology is prevailing the issue of optimized allocation of resources is very critical. Hence, organizations must continually reevaluate their existing facilities to ensure that they are consistent with both the environment's demands and the management's strategic requirements.

In this regard plant design is one of the major areas where decisions are made primarily which affect the overall performance of a manufacturing system. Facility design is typically an iterative procedure where multiple layouts are generated before a complete design is obtained. Consequently, adequate analyses of material flow are required in subsequent iterations of the facilities design cycle.

Simulation is the most suitable tool to capture such dynamic nature of operations over a spread of time. Simulation models help in evaluating the efficiency of layout for accurate, and timely analyses which are subjected to varying demand. Normally plant layout design relying completely on static analysis can be misleading in establishing a good layout since the average data does not represent for either the high demand or low demand condition. Production schedules, variations in product mixes, availability of material handling equipment, and random breakdowns create varying loads on the system. And

hence a final analysis of the material should be made to take into account such variability over a suitable planning horizon.

This thesis work involves modeling and simulation of facility layout for a system subjected to dynamic demand constraint which is studied by taking a case study of Anbessa City Bus Service Enterprise Vehicle Maintenance Facility. The Arena simulation software package was employed for modeling and simulation of the system to perform dynamic analysis.

## **1.2 Problem Statement**

Given a varying production volumes ensuring whether the production system has sufficient capacity into the plant layout avoiding bottleneck issues through either space and production flow constraints is very difficult task. And hence evaluating the performance of the existing layout requires a dynamic analysis of the production system with a given real data. In this regard a simulation and modeling of the system is the most effective method to analyze such problems.

The Anbessa City Bus Service Enterprise(ACBSE) could not provide the ever increasing service demand of the city's residents. Even though unmatched number of buses with the demand, the routing and scheduling problems, the current road status of the city and other external factors have resulted for its poor service, the under performance of maintenance facility is one of the major cause for poor service of the enterprise.

The ACBSE maintenance facility is one of the biggest vehicle maintenance centers in Ethiopia, providing maintenance services to buses for their scheduled and breakdown maintenance. The Yeka Depot Maintenance facility being the main maintenance center of the enterprise gives full fledged maintenance

services. The services mainly given in the facility constitutes body shop, machine shop, depot maintenance and preventive & corrective maintenances.

The ACBSE maintenance facility is described by its congestion and long queuing of buses for their scheduled and breakdown maintenance thus limiting the availability of buses for the service which is creating loss of good will among the public in general and the loss of revenue in particular to the enterprise.

Hence the performance the exiting facility must be evaluated to improve the prevailing conditions which requires analysis of the system.

### **1.3 Objectives of the Study**

#### **General objectives**

The general objective of the thesis is to study and analyze the performance of a plant layout using a simulation model and improve its performance with consideration of optimized plant layout and material flow by considering the case study.

#### **Specific objectives**

- Study the basics of plant layout and its performance evaluation.
- Model the maintenance facility system.
- Simulate a maintenance system with a varying dynamic demand.
- Evaluate the performance of facility layout.
- Interpret the results of simulation and make appropriate recommendation that will improve the production process.
- Remodel and simulate the system with an improved layout.

## 1.4 Methodology

The research will apply the following methods to achieve its objectives

- Review of literature in the areas of layout design, queuing, scheduling and simulation
- Study and comprehend the simulation software.
- Assess the major variables that affects the performance of maintenance facility.
- Collect required data from the existing maintenance facility at Anbessa city bus service enterprise.
- Model, Simulate and evaluate the performance of existing layout.
- Remodel and simulate the maintenance process based on the outcomes.
- Validate the result of model for comparison.
- Appropriate conclusion and recommendation are made there after based on findings and results.

## Part 2. Literature Review

### 2 Facility Layout

#### 2.1 Definitions

Facilities are the physical representation of the capacity of an operation. They promote or constrain the efficiency of operations. Facility layout is the planning, designing, and physical arrangement of processing and support areas within a facility; the goal is to create a design that supports company and operating strategies [1].

The word facility comes from the Latin *facilis*, meaning *easy*, a facility should free operations within it from difficulties or obstacles. A good layout optimizes the use of resources while satisfying other criteria such as quality, control, image, and many other factors. Because of these many factors, facilities layout is very complex. The evolution of facility structures, processes, materials handling, and other factors that influenced design.

*Facility layout* refers to the arrangement of machines, departments, workstations, storage areas, and common areas within an existing or proposed facility. Facility layout is also defined as the arrangement of activities, features and spaces in consideration of the relationship that exists between them (Hales 1984)[5].

Plant layout is a plan of, or the act of planning, an optimum arrangement of industrial facilities, including personnel, operating equipment, storage space, material handling equipment and all other supporting services, along with the design of the best structure to contain these facilities [2].

Manufacturing facilities design is the organization of the company physical facilities to promote the efficient use of the company's resources such as people, equipment, material and energy. Facilities design includes plant location and building design, plant layout and material handling.

Layout is the physical arrangement of production machines & equipment, workstations, people, location of materials of all kinds & stages and material handling [3].

## **2.2 The Need and Benefits of Efficient layout**

Everyone within an industrial organization is connected with plant layout in some way, and everyone within a plant is interested in its layout to some degree. The worker is interested in the arrangement of his work station. The foreman is interested in layout as it affects the out put of his department. Middle management is interested in layout as it affects the output and costs of its area responsibility.

Manufacturing facilities design and material handling affects the productivity and profitability of a company more than almost any other major corporate decisions. Proper layout tends to hold permanent capital investment to a minimum but does not allow plant equipment to become obsolete. It provides flexibility for methods improvement and future expansion. It eliminates wasted aisle space and uses only the essential space required by manufacturing areas. It minimizes work in process inventory levels by providing appropriate storage facilities to keep materials moving through the plant. It makes optimum use of materials handling equipment without incurring congestion.

Good layout can reduce indirect manufacturing costs by decreasing scrap and spoilage due to difficult handling situations. By providing easier access to

equipment and facilities, it will reduce maintenance and cleaning costs, which will result in further cost savings of expense supplies. Good layout also makes supervision easier and at the same time reduces the need for excessive quality checks. it aids in production control by providing smooth flow and facilitates scheduling and dispatching.

Although in a individual cases the details may be different, most plant layouts are simulated by one of the following development:

- Product design change
- New product
- Changes in volume of demand
- Facilities becoming obsolete
- Frequent accidents
- Poor worker environment
- Change in the location or concentration of markets
- Cost reduction

### **2.3 Classes of Plant layout Problems**

Plant layout problems seem to fail into the following four categories

1. Minor changes in present layouts
2. Existing layout rearrangement
3. Relocating into existing facilities
4. Building a new plant

#### ***Minor changes in Present Layouts***

In most plants small changes in layout arrangements are made quite frequently. These small changes can be brought about for any number of reasons. A method

improvement on an operation can result in layout changes. A new type of inspection plan might result in a change in the arrangement of inspection facilities. The introduction of a similar but new product into a department could bring about the rearrangement of equipment. The development of new process for turning a presently fabricated product might well mean a layout revision.

### ***Existing Layout Rearrangement***

Industries that are involved with products that require frequent redesign are faced with the problem of relayout of existing departments. Complete rearrangement of existing facilities enables a company to utilize the latest methods and procedures. A concern is more likely to abandon obsolete processes and methods when a whole department is being replanned than it is if only minor changes are being made.

### ***Relocating into Existing Facilities***

Moving to a new building or new location causes a layout problem to develop. This class of problems, as with the previous type, presents a unique opportunity to closely examine methods and processes in order to bring them up to date with a minimum of expense. Improving processes with minor changes can be costly in the long run, but when a new layout must be made in any case, it is desirable to use the latest methods to avoid rapid obsolescence.

### ***Building a New Plant***

The planning of a completely new plant requires a large amount of manpower and is the most complicated of the four classes of layout problems. The layout starts with production process and plan its arrangement. The auxiliary areas necessary to make the plant a complete and integrated operation is planned. Finally, the shell-the building to enclose these facilities-is planned so that the

building aids rather than hinders the production processes, as is often the case when the building exists and the layout must be stuffed to the most extent.

## **2.4 Objectives of Plant Layout design**

In very general terms, an optimum plant layout is one which provides maximum satisfaction to all parties concerned: that is, the employees and management, as well as the stockholders. Each of the parties involved has certain interests in obtaining a good plant layout. Keeping these interests in mind, the major objectives of a good plant layout are to:

1. Provide overall simplification
2. Minimize cost of material handling
3. Provide high work in process turnover
4. Provide effective space utilization
5. Provide for worker convenience, and promote job satisfaction and safety
6. Avoid unnecessary capital investment
7. Stimulate effective labor utilization

### ***Effective Space Utilization***

Making good use of space involves considering not only production and storage areas, but also the floor area required by service departments. Stock bins spread out on only one level, idle aisles, and unorganized storage areas all mean poor space utilization. The cost of floor space varies from one location to another, but companies should have given considerable thought to accurately calculating floor area cost on a dollar per square foot basis.

### ***Unnecessary Capital Investment***

Capital investment in equipment can sometimes be reduced by the proper arrangement of machines and departments. During the process planning phase

capital investment can be minimized by making use of idle time on presently owned equipment.

## **2.5 Layout Design Procedures**

A number of procedures have been developed to facilitate the design of plant layouts. Some of the more significant contribution to the layout design are the ideal systems approach by Nadler with the layout planning and steps recommended by Immer, Apple and Reed[1]. Generally the common approaches are:

1. Nadler's Ideal Systems Approach
2. Immer's Basic Steps
3. Apples Plant Layout Procedure
4. Reeds plant layout Procedure

### **2.5.1 Systematic Layout Planning**

Over the years, the most popular approach used in designing plant layouts has been the systematic layout planning (SLP) approach developed by Muther[ 2]. SLP has been applied to production, transportation, storage, supporting services, and office activities among others.

The SLP consists of three main steps i.e analysis, search and selection. The analysis phase involves all of the data collection required to produce a good layout. Within the analysis phase, the facility data is utilized to define the departmental relationships. Muther utilized closeness ratings[A,E,I,O,U] in order from strongest attracted to strong repelled instead of cost ratings to indicate departmental relationships.

The search phase of SLP involves the actual layout generation. The analysis phase produces data from which a relationship diagram can be developed; the

relationship diagram shows the relative location of each with no space considerations. The space relationship diagram is developed to show the location of each department with space considerations. The technique proposed herein generates a space relationship diagram directly from the facility data without first generating a relationship diagram. Some modifications must then be performed on the space relationship diagram before it can be considered a feasible layout; the user may move departments in order to properly fit them into facility or if any other limitations have not been previously considered. After layouts have been generated, the selection phase of SLP is executed. Each layout is evaluated based upon the solvers metrics(cost, closeness). The best layout is the selected based upon best performance with respect to the metric.

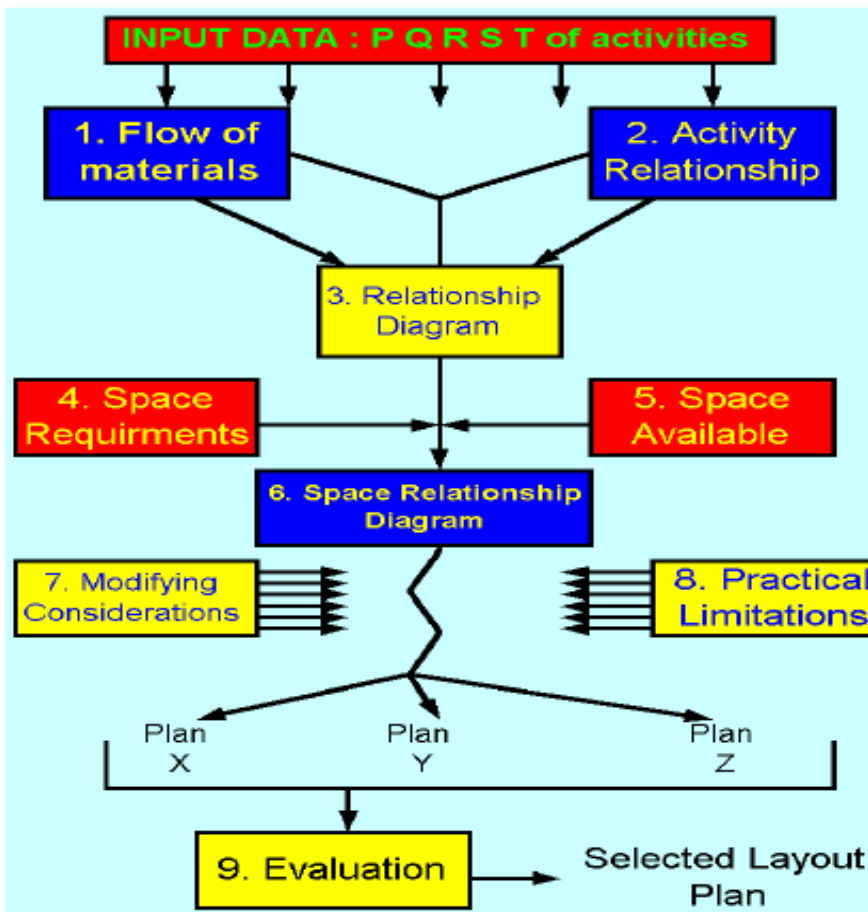

Figure 2-1 Systematic Layout Planning (SLP)[2]

### 2.5.2 Approaches for Facility Layout Problem (FLP)

In an effort to design and evaluate alternative layouts, many optimization approaches were proposed.

- **Mathematical modeling** demonstrates an optimal solution but only in case of small or greatly restricted problems (Foulds and Robinson, 1978; Montreuil and Raliff, 1989; Boswell, 1992).
- **Heuristics** can usually give a sufficient (but not optimal) solution quickly in case of large-scale problems (Jaydeep Et. Al, 2003). These algorithms are available as layout software packages.
- Finally, literature provides also some hybrid algorithms that represent a combination of approaches. For instance, Dunker et al. (2005) presented an algorithm that combines dynamic programming and genetic search for solving a facility layout problem.

Despite their effectiveness, these approaches imply difficult-to-use mathematical formulations and in addition, require accurately defined design objectives and constraints. Approaches based on graphical representation were developed in order to offer more comprehensible procedures, the possibility of adding multidimensional factors and not having accurately defined elements. Systematic Layout Planning (SLP) represents this category (Muther, 1973)[1]. However, this approach focuses on a functional way of thinking. Thus, in order to “get away from the functional mindset and meet today’s rapidly changing strategic operations needs”, the Strategic Facility Planning (SFP) was built on the earlier approach of SLP.

However, none of the above methods looked at the facility layout problem as a large scale reengineering project. Thus, integrated facilities reengineering approaches were developed. The most effective one seems to be that of the FacPlan method.

A step forward is that of simulation modeling. While it is certainly not a scientific measure, simulation models can be an extremely valuable, timely and cost-effective means to study the performance characteristics of a proposed layout. By providing system wide views of the impact of changes to the existing system without physically building, amending or interrupting the system, simulation offers a platform to validate the effectiveness of an altered design.

## **2.6 Performance Evaluations of Facility layout**

The most difficult part of the plant layout procedure is the evaluation of the various alternative proposals. To date, no procedure for evaluating layout alternatives has achieved general acceptance. It may well be that each layout problem is so unique that a general evaluation procedure can not be found.

The best layout is always a compromise of the various factors, consideration, layout objectives. To select the best compromise plan alternative layout proposals and eliminate those or the portions of them that compare unfavorably.

The evaluation of alternative plant layouts has hardly been mentioned, even though the plant layout problem is very old, because of the lack of suitable measure of effectiveness. Discovering the proper measure of effectiveness- that is an explicit measure of the extent to which a layout is achieving its goal is essential to proper layout evaluation. For example in case where material handling is the primary problem in establishing a new layout the distance moved by a product could perhaps be considered s proper measure of effectiveness, but

in another situation the number of idle machine hours could be considered proper. One over all measure of effectiveness generally consists of two components:

1. The importance of the objectives
2. The efficiency of the alternative layouts.

In plant layout problems the objective may be qualitative in nature .Qualitative objectives are usually psychological and social and are often classed as intangible objectives. Plant layout must wrestle with these intangible qualitative objectives. Qualitative objectives are usually psychological and social and are often classed as intangible objectives. Plant layout must wrestle with these intangible qualitative objectives.

Techniques for evaluating layout may be generally classified as

1. Systematic
2. Optimizing

The systematic techniques of evaluation provide an organized approach to selecting the best layout. The optimizing techniques guarantee that the final solution is the best that, under the given set of conditions with the chosen measure of effectiveness, it can not be improved further. Systematic evaluation may lead by trial and error to the optimum solution, but there is no assurance of this.

### ***Systematic Evaluation***

There are many ways that layout solutions may be systematically evaluated. The following systematic approaches will be discussed here:

- Pilot plant
- Cost comparison
- Productivity comparison
- Space evaluation

- Sequence demand-straight line
- Sequence demand- non directional
- Factor analysis
- Ranking
- Pros and Cons

### *Optimizing Evaluation*

- Linear programming
- Line balancing
- Level Curve Concept

### **Computerized Layout Evaluation**

A number of block layout programs are capable of generating several (or many) alternative layouts but reporting only the best or the best few.

1. Adjacency Based Scoring
2. Distance Based Scoring
3. Distance Weighted Adjacency Based Scoring

## **2.7 Computerized layout planning**

### **2.7.1 Computerized Layout Generation**

There are two categories of computerized layout programs the first one are those that simply automate some of the drafting or calculation tasks, leaving all the decisions to the layout planner and those that generate alternative layouts.

Computerized layout generation algorithms fall into one of two distinct categories. *Construction algorithms* start with the basic SLP data, some subset of it and build a block layout by iteratively adding one more activity to partial layout until all activities have been placed. The algorithm may in fact build a large number of layouts and report only the best of them.

*Improvement algorithms*, as the name suggest require in addition, an initial block layout which they then attempt to improve. Without the scoring model construction algorithms would not know which the best layouts nor would improvement algorithms know when an improvement had been made.

## **2.7.2 Facility Layout Planning Tools**

There are numerous facility layout planning tools on the market today. Most of these tools focus on analytical relationship diagrammatic techniques. An LPT allows the facility designed to quickly evaluate various layouts options. The goal is to develop a facility layout that satisfies the constraints while keeping the non value added movement of material or product at minimum. A substantial amount of information in this system is also used in simulation models. Examples of transferable information's are distances, process routes for materials, size of containers being transported, method of transportation for the material and flow rates between the different areas in manufacturing operations.

General purpose Computer Aided Design( CADD) systems can be used to cerate modify, store, retrieve and display layout drawings in effect as an electronic drafting table and drawing file. Standard blocks, or icons in the CADD system can automate the drawing of standard layout elements, such as building structures( doors, windows, walls, posts etc.) furniture or machines.

Generic Data Base Management System(DBMS) software's can be used by the layout planner for creating, storing, manipulating, retrieving and displaying both numeric and text data. Such systems are available for computing platforms ranging mainframes down to workstations or personal computers. There are a number of classical decisions aids for block layout planning which are most often referred to as layout programs. The classical layout programs CRAFT,

CORELAP, ALDEP and PLANET all organized in the early and mid 1960s, so many variations have appeared over the years.

## **2.8 Plant Layout Simulation**

Perhaps the most popular criterion used to minimize some function of distance traveled. Within an industrial setting, it is argued that minimizing distance will minimize material handling cost. However, it may be the case that reducing distance creates congestion in a concentrated area and material handling costs increase. Plant designers generally have only two choices: either physically change the layout of an existing facility and then measure results, or model the system and measure results to develop the final facility design before making changes. Plant layout simulation is a tool that uses data to evaluate a current facility layout and show potential improvement areas. The same data is then used to objectively evaluate various layout alternatives for new construction, additions, and/or re-organizations.

Facilities planners can use simulation to study various aspects of facilities design, capacity planning, inventory policies, office and parking lot layouts, quality and reliability systems, ware housing and logistics planning, and maintenance scheduling, to name a few possibilities. They can evaluate alternatives in material handling systems such as fork trucks, AGV, automated storage and retrieval system(AS/RS), and transport and accumulation conveyors. By using simulation, the planner can compare different alternatives and study various scenarios to determine, for example, whether in a given situation a conveyor would be more effective than robot or an AGV.

Currently a number of user friendly advanced simulation and layout planning packages are available to facilities planners at affordable costs. These software packages offer tremendous potential in aiding the process of planning and optimizing the entire facility, a computer production system, or only a small department, or as a tool in balancing a simple assembly line. The limitations go only as far as the planner's imagination.

## **2.9 Benefits of plant layout simulation**

Implementing plant layout simulation can

- Provide a systematic, cost-effective means of evaluating layout scenarios based on data generated and priorities developed in-house, while utilizing both internal and external resources to carry out the evaluation process.
- Provide objective data to aid in the decision-making process before costly changes or investments are made.
- Maximize the chances of successful implementation by including key personnel in the planning process.
- Sharpen team problem-solving skills and improve communication between employees and management.

## 3 Simulation

### 3.1 Definition

Simulation is defined as an experimental technique, usually performed on a computer to analyze the behavior of any real world operating system. Simulation involves the modeling of a process or a system where the model produces the response of the actual system to events that occur in the system over a given period of time[4].

Simulation can be used to predict the behavior of a complex manufacturing or service system by actually tracking the movements and the interaction of the system components. The simulation software generates reports and detailed statistics describing the behavior of the system under study. Based on these reports, the physical layouts, equipment selection, operating procedures, resource allocation and utilization, inventory policies and other important system characteristics can be evaluated.

Equipments utilization or breakdown, material handling and transportation systems' behavior, and interaction among various activities in a manufacturing cell, for instance, are dynamic in nature and the output of such models is a function of time.

The use of computer simulation and modeling can also facilitate an understanding for non-normal probability distribution such as exponential, the Poisson or the binomial. Contrary to popular belief or wishes, not all phenomena in a manufacturing facility, or in industry in general, have a normal probability distribution.

In the scope of facilities planning and design, computer simulation can be utilized to study and optimize the layout and capacity, JIT inventory policies, material handling systems, warehousing and logistics planning. Computer simulation allows the comparison of different alternatives and studies various scenarios in order to select the most suitable setup.

Random events occur in nature in manufacturing in the service industry and just about every where we look. If the world around us worked on the advantages simulation tools would not be necessary. The world could be analyzed with spreadsheet and calculators. In complex systems where many sources variability and randomness usually exists, simulation tools are valuable in analyzing the complex interaction of the numerical random variables.

### **3.2 The Need of Simulation**

Models used to study large scale systems tend to be very complex, and writing computer programs to execute them can be arduous task indeed. This task has been made much easier in recent years by the development of excellent software products that automatically provide many of the features needed to program a simulation models.

“You cannot study a system by stopping it.” Frank Herbert[12].

(If the system was stopped long enough to analyze it, it would alter the nature of the system. Thus, the only way to study it properly was while it was in motion. Computer simulation allows the model of the system to be in motion.)

#### **Gaining Insight into the Operation of a System**

Some systems are so complex that it is difficult to understand the operation of and interactions within the system without a dynamic model. In other words, it may be impossible to study the system by stopping it or by examining individual components in isolation. A typical example of this would be to try to understand how manufacturing process bottlenecks occur.

### **Developing Operating and Resource Policies**

You may also have an existing system that you understand but wish to improve. Two fundamental ways of doing this are to change operating or resource policies. Changes in operating policies could include different scheduling priorities for work orders. Changes in resource policies could include staffing levels or break scheduling.

### **Testing New Concepts**

If a system does not yet exist, or you are considering purchasing new systems, a simulation model can help give you an idea how well the proposed system will perform. The cost of modeling a new system can be very small in comparison to the capital investment involved in installing any significant manufacturing process. The effects of different levels and expenses of equipment can be evaluated. In addition, the use of a simulation model before implementation can help refine the configuration of the chosen equipment.

### **Gaining Information without Disturbing the Actual System**

Simulation models are possibly the only method available for experimentation with systems that cannot be disturbed. Some systems are so critical or sensitive that it is not possible to make any types of operating or resource policy changes to analyze the system. The classical example of this type of system would be the security checkpoint at a commercial airport. Conducting operating policy or resource level experimentation would have serious impact on the operational capability or security effectiveness of the system.

Simulation modeling practices can be performed for a variety of reasons:

1. *Evaluation* : determine and measure how well a proposed system design performs in absolute sense when compared against criteria. Does the system meet these criteria; that is , does it meet the production requirement, can it perform within the budget, and so on.

2. **Comparison:** Compare alternative designs to carry out a specific function. Planners can select from various alternatives by critically comparing them for cost, performance and other factors.
3. **Prediction:** It allows the planner to investigate the performance of a proposed system under specific conditions over period of time. Under the stipulated conditions, the performance of a system can be stimulated over a period of hours, days or even years, in a matter of minutes or hours.
4. **Sensitivity analysis:** although there may be many variables operating in a system, only a few may critically affects the performance of the process. Sensitivity analysis helps determine which of the many factors and variables have the greatest effects on the overall operations of the system.
5. **Optimization:** Once the critical factors have been isolated, you can attempt to optimize the plan by establishing what factors or which combination of factors produces the best overall system response.
6. **Bottleneck analysis:** the facilities planner can discover the nature an location of bottlenecks affecting the flow of the system.

### **3.3 Benefits of Simulation**

1. **Extremely fast execution.** A simulation model can typically generate a new schedule in a few seconds or minutes. This is critical in responding to unplanned events such as material shortages or machine breakdowns.
2. **Flexible decision logic.** Simulation can incorporate a wide range of decision rules to focus on any type of objective or represent any type of complex decision-making incorporating factual data.
3. **Simple implementation.** Simulation-based finite capacity scheduling is relatively simple to implement. This lowers the cost and reduces the implementation time.

4. *High quality schedules.* Compared to alternate methods that load an entire job at a time, simulation can generate very high quality schedules that often do a better job of maximizing resource utilization.

#### **5. Experimentation in Compressed Time**

Because the model is simulated on a computer, experimental simulation runs may be made in compressed time. This is a major advantage because some processes may take months or even years to complete.

Lengthy system processing times may make robust analysis difficult or even impossible to perform. With a computer model, the operation and interaction of lengthy processes can be simulated in seconds. This also means that multiple replications of each simulation run can easily be run to increase the statistical reliability of the analysis. Thus, systems that were previously impossible to analyze robustly can now be studied.

#### **6. Reduced Analytic Requirements**

The development of simulation specific software packages has helped insulate practitioners from many of the complicated background calculations and programming requirements that might otherwise be needed. These reduced analytic requirements have provided more practitioners, with a wider variety of backgrounds, with the opportunity to analyze many more different types of systems that are previously not possible.

#### **7. Easily Demonstrated Models**

Most simulation-specific software packages possess the capability of dynamically animating the model operation. Animation is useful both for debugging the model and also for demonstrating how the model works. Animation-based debugging allows the practitioner to observe flaws in the model logic easily. The use of animation during presentation can help establish model credibility.

Animation can also be used to describe the operation and interaction of the system processes simultaneously. This includes dynamically demonstrating how the system model handles different situations.

### **3.4 Basic Simulation Components**

Simulation modeling and analysis is the process of creating and experimenting with a computerized mathematical model of a physical system [8].

A system is defined to be a collection of entities e.g people or machines that act and interact together toward the accomplishment of some logical end. A system is well defined collection of entities. Entities are characterized by data values called attributes, and these attributes are part of the system state for discrete event simulation[9].

The facility or process of interest is usually called a system, in order to study it scientifically we often have to make a set of assumptions about it works. These assumptions, which usually take the form of mathematical or logical relationships, constitute a model that is used to gain some understanding of how the corresponding system behaves.

As an example of the use of simulation, consider a manufacturing company that is contemplating building a large extension onto one of its plants about is not sure if the potential gain in productivity would justify the construction cost. It certainly would not be cost effective to build the extension and then remove it later if it does not work out. However a careful simulation study could shed some light on the question by simulation the operation of the plant as it currently exists and as it would be if the plant were expanded.

Each of these simple systems consists of three types of major components:

- Entities
- Queues
- Resources

### **3.4.1 Entities**

The first type of component is an entity: something that changes the state of the system. In many cases, particularly those involving service systems, the entity may be a person. In the customer service center, the entities are the customers. Entities do not necessarily have to be people; they can also be objects.

### **3.4.2 Entity Attributes**

Entities may also possess attributes. These are variables that have values unique to each entity in the system. Even though the entity attribute will have the same name, there could be as many different values as there are entities. An example of an attribute of this type involves the entity's arrival time.

Simulation programs may also utilize global variables. Global variables are not to be confused with entity attributes. These variables differ from entity attributes in that each global variable can maintain only one value at a given time. A typical use of a global variable in a simulation program is the variable that keeps track of the simulation run time.

### **3.4.3 Queues**

The second major type of components that simple systems possess is queues. Queues are the simulation term for lines. Entities generally wait in a queue until it is their turn to be processed. Simple systems generally use first-in-first-out (FIFO) queue priorities. Another characteristic of simple systems is that once customers enter the system, they must enter the queue. Furthermore, once entities enter the queue, they cannot depart before receiving service.

### 3.4.4 Resources

The third component that simple systems contain is resources. Resources process or serve the entities that are in the queue.

In simple models, resources can be either idle or busy. Resources are idle when they are available for processing, but there are no more entities waiting in that systems contain is resources. Resources process or serve the entities that are in the queue.

		Resource status	
		Idle	Busy
Entities Status	No Entities in the system	Possible A	Impossible
	Entities are present	Impossible	Possible B

Figure 3-1 Resource Status

The fraction of time the resource is busy provides its utilization.

## 3.5 System Classifications

### 3.5.1 System Types

There are different ways to study systems those are discussed in the following table

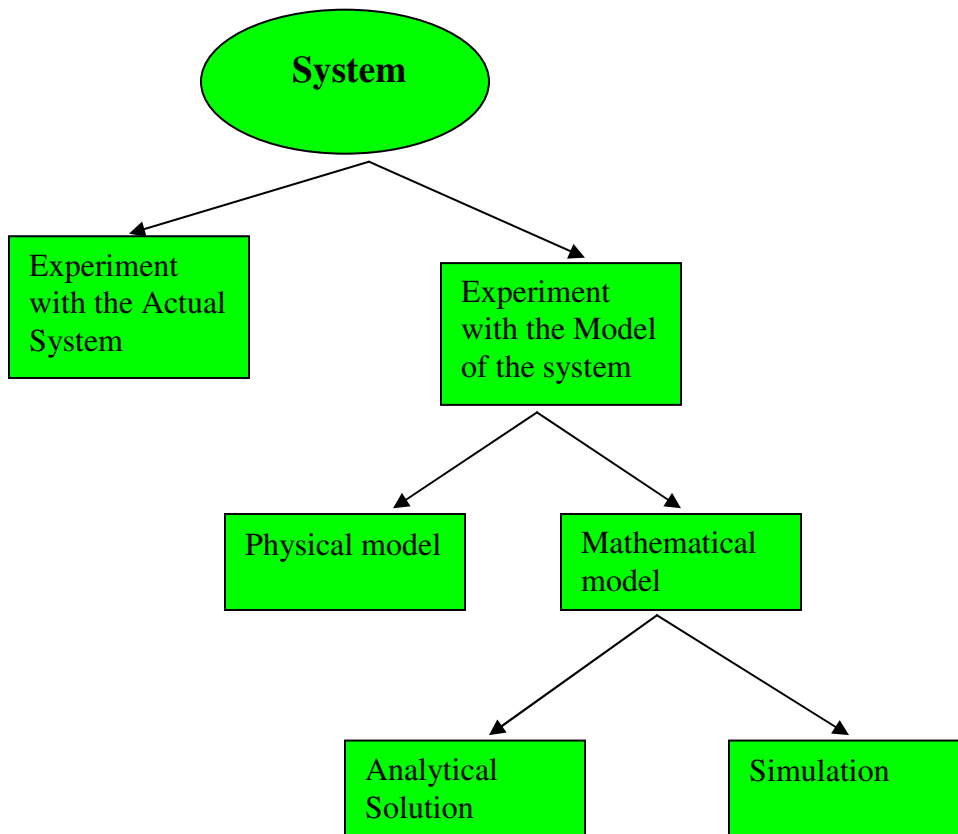

Figure 3-2 *System Types*

#### **Experiment with the Actual System vs Experiment with a Model of the System**

If it is possible and cost effective to alter the system physically and then let it operate under the new conditions, it is probably desirable to do so, for in this case there is no questions about whether what is studied is valid. However, it is rarely feasible to do this, because such an experiment would often be too costly or too disruptive to the system. ore graphically the system might not even exist,

but we nevertheless want to study it in its various proposed alternative configurations to see how it should be built in the first place. For these reasons it is usually necessary to build model as a representative of the system and study it as a surrogate for the actual system.

### **Physical model vs Mathematical model**

It has been found useful to build physical models to study engineering or management systems examples include table top scale models of material handling systems and in at least one case a full scale physical model of fast food restaurant. But the vast majority of models built for such purposes are mathematical, representing a system in terms of logical and quantitative relationships that are then manipulated and changed to see how the model reacts and thus how the system would react if the mathematical model is valid one.

### **Analytical Solution vs Simulation**

Once we have built in mathematical model, it must then be examined to see how it can be used to answer the questions of interest about the system it is supposed to represent. If the model is simple enough it may be possible to work with its relationships and quantities to get the exact analytical solution. Many systems are complex, so that valid mathematical models are also complex, precluding any possibility of analytical solution. In case the model must be studied by means of simulation, i.e numerically exercising the model for the inputs in question to see how they affect the output measures of performance.

### 3.6 Simulation Models

Given then that we have mathematical model to be studied by means of simulation we must then look for particular tools to do this. It is useful for this purpose to classify simulation models along three different dimensions:

- **Static vs Dynamic Simulation Models.** A static simulation model is representative of a system at particular time, or one that may be used to represent a system in which time simply plays no role: examples of static simulation Monte Carlo models. A dynamic simulation model represents system as it evolves over time, such as conveyor system in a factory.
- **Deterministic vs Stochastic Simulation Models .** If a simulation model does not contain any probabilistic(i.e random) components, it is called deterministic; a complicated and analytically intractable system of differential equations describing a chemical reaction might be such a model. In deterministic models the output is determined once the set of input quantities and relationships in the model have been specified, even though it might take a lot of computer time to evaluate what it is. Many systems however must be modeled as having at least some random input components and these give to stochastic simulation models.
- **Terminating vs Non terminating Simulation models.** The status of the system at the beginning of the period of interest is one means of distinguishing between a terminating and non terminating system. Terminating systems generally start each time period without any influence from the previous time period. A second means of identifying whether a system is terminating or non terminating is the existence of a natural terminating event. This may be the shutting down of the system at particular point in time or the end of a busy period that is of specific interest to the practitioner.

### 3.7 Simulation Types

#### Discrete Event Simulation

Discrete event simulation concerns the modeling of a system as it evolves over time by a representation in which the state variables change instantaneously at separate points in time. In more mathematical terms we might say that the system can change at only a countable number of points in time. These points in time are the ones at which an event occurs, where an event is defined as an instantaneous occurrence that may change the state of the system.

#### Continuous Simulation

Continuous simulation concerns the modeling over a period in which the state variables change continuously with respect to time. Typically continuous simulation models involve differential equations that give relationships for the rates of change of the state variables with time.

### 3.8 Data Collection & Analysis

In a simulation project the ultimate use of input data is to derive the simulation.

This process involves the collection of input data, analysis of the input data, and use of the analysis of the input data in the simulation model. The input data may be either obtained from historical records or collected in real time as a task in the simulation project. The analysis involves the identification of the theoretical distribution that represents the input data. The use of input data in the model involves specifying the theoretical distributions in the simulation program code.

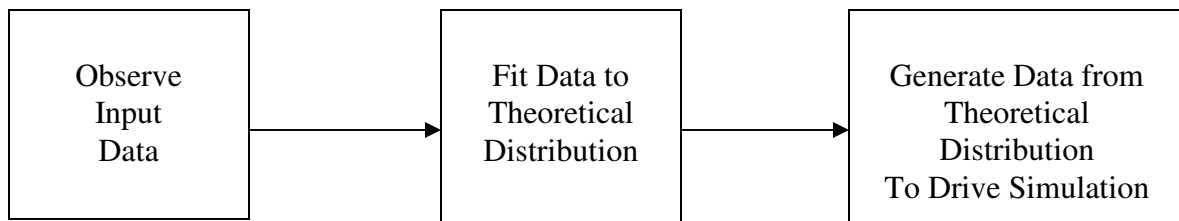

Figure 3-3 *Distribution fittings*

### 3.8.1 Sources for Input data

There are many sources that the practitioner can tap to acquire input data. This data can be historical, anecdotal, or observational. Even if an actual system model does not exist, it is possible for the practitioner to acquire the needed input data from other sources. Sources that are available include:

- Historical Records
- Manufacturing Specification
- Vendor claims
- Operator estimates
- Management estimates
- Automatic data capture
- Direct observation

### 3.8.2 Data type

While collecting the input data there are different classifications of data. One method of classifying data is deterministic or probabilistic. Each individual project will call for a unique set or type of input data. Some of the types of input data may be deterministic, and other types are probabilistic.

#### *Deterministic Data*

Deterministic data mean that the event involving the data occurs in the same manner or in a predictable manner each time. This means that this type of data needs to be collected only once because it never varies in value.

#### *Probabilistic Input Data*

In contrast to determine processes, a probabilistic process does not occur with the same type of regularity. In this case, the process will follow some probabilistic. Thus it is not known with the same type of confidence that the follow an exactly known behavior.

### 3.8.3 Input Probability Distributions

To carry out a simulation using random inputs such as inter arrival times or demand sizes, we have to specify their probability distributions. Given that the input random variables to a simulation model follow particular distributions, the simulation proceeds through time by generating random values from these distributions.

Most common probability distributions:

Discrete Distributions

- Bernoulli
- Uniform
- Poisson

Continuous Distributions

- Exponential
- Normal
- Triangular
- Weibull
- Gamma
- Beta
- Geometric
- Erlang
- Lognormal

Based on the collected data on an input random variables of interest the data can be used in one of the following approaches to specify a distribution.

1. The data values themselves are used directly into the simulation.(sometimes called a trace driven simulation)
2. The data values themselves are used to define an empirical distributions function
3. Standard techniques of statistical inference are used to fit a theoretical distribution form.

### *Exponential distributions*

- Expression - expo( $\mu$ )
- Density function  $f(x) = \frac{1}{\mu} e^{-x/\mu}$  if  $x \geq 0$   
0 otherwise
- Distribution  $F(x) = 1 - e^{-x/\mu}$  if  $x \geq 0$   
0 otherwise
- Mean  $\mu - \overline{X(n)}$
- Variance  $\mu^2$

### *Normal distribution*

- Expression norm( $\mu, \sigma^2$ )
- Density function

$$f(x) = \frac{1}{\sigma\sqrt{2\pi}} e^{-(x-\mu)^2/2\sigma^2}$$

- Variance  $\sigma^2$
- Mean  $\mu - \overline{X(n)}$

### *Weibull Distribution*

- Expression weibull( $\alpha, \beta$ )
- Density function

$$f(x) = \alpha\beta^{-\alpha} x^{\alpha-1} e^{-(x/\beta)^\alpha}, \text{ for } x > 0, 0 \text{ otherwise}$$

$$\Gamma = \int_0^\infty x^{\alpha-1} e^{-x} dx$$

- **Mean**

$$\text{mean} = \frac{B}{\alpha} \Gamma\left(\frac{1}{\alpha}\right)$$

- Variance

$$\text{variance} = \frac{\beta^2}{\alpha} \left\{ 2\Gamma\left(\frac{2}{\alpha}\right) - \frac{1}{\alpha} \left[ \Gamma\left(\frac{1}{\alpha}\right) \right]^2 \right\}$$

### ***Beta Distribution***

- Expression beta( $\alpha_1, \alpha_2$ )
- Density function

$$f(x) = \frac{\Gamma(\alpha + \beta)}{\Gamma(\alpha)\Gamma(\beta)} x^{\alpha-1}(1-x)^{\beta-1}, \text{ for } 0 < x < 1, 0 \text{ elsewhere}$$

Where  $\alpha_1, \alpha_2$  shape parameters 1 and 2 respectively, and  $\Gamma$  is defined as for the weibull distribution.

- Mean

$$\text{mean} = \frac{\alpha}{\alpha + \beta}$$

- Variance

$$\text{variance} = \frac{\alpha\beta}{(\alpha + \beta)^2(\alpha + \beta + 1)}$$

### **3.8.4 Distribution Fitting Checks**

After determining one or more probability distributions that might fit our observed data we must examine these distributions to see how well they represent the true underlying distribution for our data. If several of these distributions are representative, we must also determine which distribution provides the best fit. In general, none of our fitted distributions will probably be exactly correct. What we are really trying to do is to determine a distribution that is accurate enough for the intended purpose of the model.

In this section we discuss both heuristic procedures and goodness of fit hypothesis tests for determining the quality of fitted distributions.

1. *Heuristic Procedures*

- Density/Histogram Over plots and frequency comparisons
- Distribution Function differences plots
- Probability plots

2. *Goodness of fits Tests*

A Goodness of fits test is a statistical hypothesis test that is use to assess formally whether the observations are independent sample from a particular distributions with distribution function  $f$ . That is a goodness of fit test can be used to test the following null hypothesis.

- Chi square tests
- Kolmogrov Smirov tests
- Anderson Darling tests
- Poisson Process Tests

### 3.9 Steps in Simulation study.

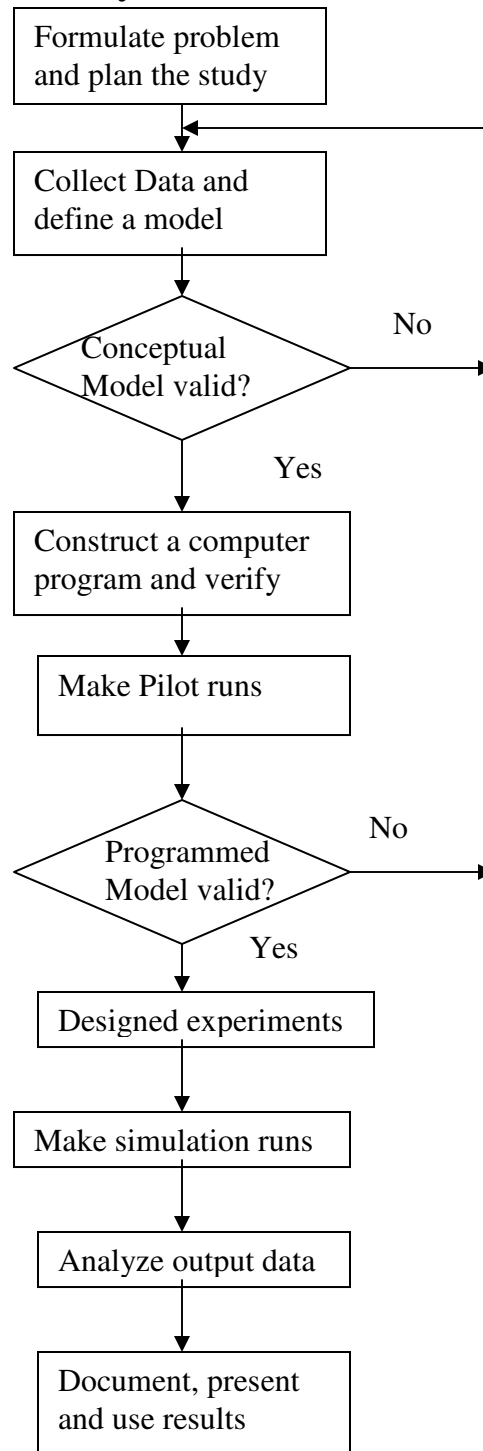

Figure 3-4 *Basic Simulation steps*

**Model verification** is concerned with determining whether the conceptual simulation model has been correctly translated into a computer program i.e debugging the simulation computer program. Although verification is simple in concept, debugging a large scale simulation program is a difficult and arduous task due to the potential large number of logical paths.

**Validation** is the process of determining whether a simulation model is an accurate representation of the system, for the particular objectives of the study. The most definitive test of a simulation model's validity is to establish that its output data closely resemble the output data that would be expected from the actual system.

### **3.10 Arena Simulation Environment**

Arena is a general purpose simulation package marketed by Systems Modeling Corporation (Sewickley, Pennsylvania). Modeling constructs, which are called modules in Arena, are arranged into a number of templates such as Basic Process, Advanced Process, Advanced Transfer. The Basic Process template contains modules that are used in many models (e.g for modeling entity arrival, departure, and service). The advanced Process panels contains modules that are used to perform very specific logical functions such as choosing queues when several are available or coordinating the advancement of multiple entities in different areas of a system. Finally the advanced Transfer template contains modules (e.g conveyors and transporters) that are used to describe the transfer entities from one part of a system to another.

A model constructed in Arena by dragging and dropping modules into the model window, connecting them to indicate the flow of entities through the simulated system, and then detailing the modules using dialog boxes or Arena built in spread sheet. A model can have an unlimited number of levels of

hierarchy. Arena has two dimensional animation and also allows the display of dynamic graphics (e.g histograms and time plots).

There are essentially unlimited number of random number streams available in Arena. Furthermore the user has random number streams available in arena. further more, the user has access to 12 standard theoretically probability distributions and to empirical distributions. Arena has a built in capability for modeling non stationary Poisson processes which is model for entity arrival with a time varying rate.

There is an easy mechanism for making independent replications of particular simulated system and for obtaining point estimates and confidence intervals for performance measure of interests. It is also possible to construct a confidence interval for the difference between the means of two systems. A number of plots are available, such as histograms, bar charts, time plots and correlation plots. An optional optimization module is also available.

Arena contains constructs for modeling several kinds of material handling devices such as conveyors transport an accumulating, forklift, and automated guided vehicle systems.

Activity based costing (ABC) is incorporated into Arena providing value assessed non value added cost and time reports. Simulation results are stored in a database and are presented using crystal; reports which is embedded in Arena.

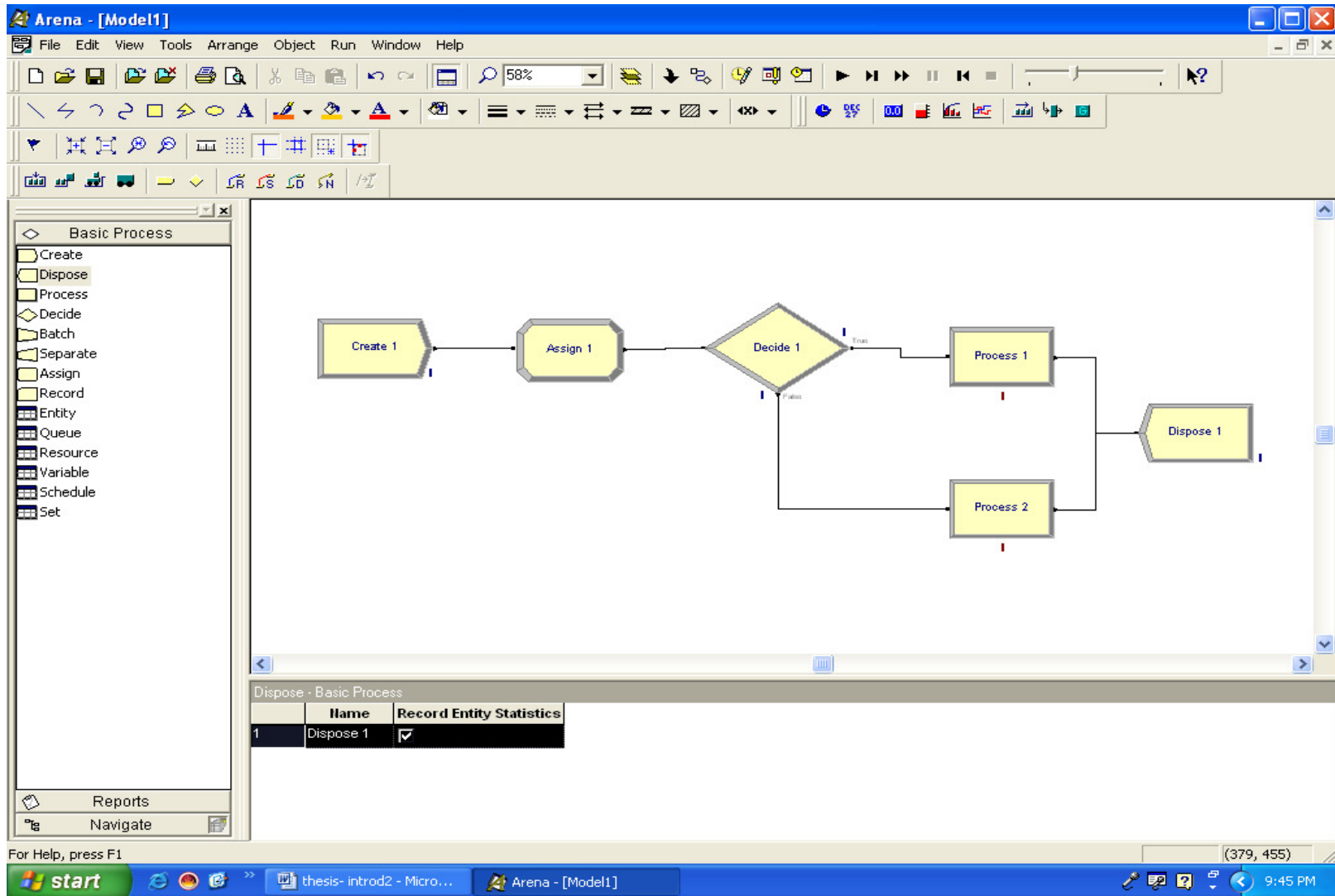

Figure 3-5 Arena Simulation Environment

## 4 Queuing Theory

The origin of queuing theory dates back to 1909, when Agner Krarup Erlang (1878-1929) published his fundamental paper on congestion in telephone traffic. In addition to formulating in analytic form several practical problems arising in telephony and solving them, Erlang laid solid foundations for queuing theory in terms of the nature of assumptions and techniques of analysis: these are being routinely used to this day even in wider areas of modern communications and computer systems. In a way, Erlang was a pioneer in the applications of analytical methods to operational problems.

Kendall (1951, 1953) was the pioneer who viewed and developed queuing theory from the perspective of stochastic processes.

Queuing theory is the mathematical study of "queues" or "waiting lines". A queue is formed whenever the demand for service exceeds the capacity to provide service at that point in time. A queuing system is composed of customers or units needing some kind of service who arrive at a service facility where such service is provided, join a queue if service is not immediately available and eventually leave after receiving service. There are also cases where customers leave the system without joining the queue or leave without receiving service even after waiting some time.

The terms customers and server are generic ones. Customers are those who need some kind of service and arrive at a facility where such service is available. A mechanism that performs the kind of service on customers or units fed into it is called a server or a service channel where such a facility is provided is considered

the server. A customer receiving service is said to be in service. If upon arrival a customer finds the server it forms or joins a queue.

## **4.1 Basic characteristics of Queuing System**

The basic characteristics of a queuing system are as follows:

- i. The input or arrival pattern of customers;
- ii. The pattern of service;
- iii. The number of servers or service channels;
- iv. The capacity of the system ; and
- v. The queue discipline

### **4.1.1 The input or Arrival pattern of customers**

The input pattern means the manner in which the arrivals occur. It is specified by the inter arrival time between any two consecutive arrivals. A measure usually considered is the average length of the inter arrival time or its reciprocal, the average number of arrival per unit of time. The input pattern also indicates whether the arrivals occur single or in groups or batches. If in batches, the manner in which these batches are constituted is also to be covered in the input pattern. The inter arrival time may be deterministic, so it is the same between any two consecutive arrivals, or it may be stochastic, when its distribution is also to be specified. The arrivals may occur from an infinite source or sometimes from a finite source, with the same units circulating in the system that is machines coming for repair whenever they fail.

### **4.1.2 The Pattern of service**

By the pattern of service, we mean the manner in which the service is rendered. It is specified by the time taken to complete a service .the time may be

constant(deterministic) or it may be stochastic. If it is stochastic, the pattern specification involves the distribution of service time of a unit. A measure typically considered is provided by the average time required to serve a unit or by the average number of units served per some unit of time.

#### **4.1.3 The number of servers**

A system may have a single server or a number of parallel servers. An arrival who finds more than one free server may choose at random any one of them for receiving service. If he finds all the servers busy, he joins a queue common to all the servers. The first customers from the common queue goes to the server who becomes free first.

#### **4.1.4 The Capacity of the system**

A system may have an infinite capacity that is the queue in front of the servers may grow to any length. Against this there may be limitation of space, so that when the space is filled to capacity, an arrival will not be able to join the system and will be lost to the system. The system is called a delay system or a loss system, according to whether the capacity is infinite or finite. If finite, it will have to be specified by the number of places available for the queue as well as for the one being served, if any.

#### **4.1.5 The Queue discipline**

The queue discipline indicates the manner in which the units are taken for service. The usual queue discipline is first come, first served, or FCFS,(first in first out(FIFO)). Though some times there are other service disciplines, such as last come, first served( which happens sometimes in case of messages or service in random order.

Queue priority means that the order of the entities in the queue may change according to the priority scheme. These are also sometimes called ranking criterion orders. In any event, there are many different types of queue priorities:

- First in First out(FIFO)
- Last in first out(LIFO)
- Shortest Processing time (SPT)
- Longest processing time(LPT)
- Lowest Value First(LVF)
- Highest value first(HVF)
- User defined

## **Part Three - Case study Presentation**

### **5 Overview of the Company**

#### **5.1 Company Profile**

Anbessa City bus service started its operation for the first time with 12 city and 18 regular buses. And in 1944 ACBSE became formally incorporated jointly financed by government and private share holders but was nationalized in 1974. Anbessa was originally a private enterprise holding an exclusive franchise for the provision of passenger transport services in the city, but was nationalized in 1974.

The federal government now owns the company, but its operations are financially supported by the city. A subsidy is paid for each passenger carried, however this subsidy is being progressively reduced and the city is committed to its eventual elimination which has declined from 26cents per passenger to 10 cents per passenger.

Anbessa has approximately 449 DAF brand buses which are bought in the years 1988-1996 which have given services for more than five years, and most of the 260 Mercedes brand buses are out of major services due to long service years and spare part problems. Those old Mercedes buses are used for special services and school bus service.

Its operations are managed from its three depots from Megnegna, Mekanisa and Sheogle. Anbessa operates in 92 routes. Most of which are radial routes to the central business and commercial areas of the city. The current bus routing and scheduling plan for Anbessa is prepared internally by the company. The fare charged for any journey is the fare applicable to that route, and is not related to the distance traveled by the passenger. Currently the enterprise gives service to

more than 500,000 passengers per day. And there are a total of 3,150 employees hired by the enterprise.

Major service of the enterprise constitutes :

- General public bus transport
- Contract transport service
- Advertisement
- Mobile crane service
- School bus service

## **5.2 Anbessa Maintenance Facility Organization**

The maintenance given on the enterprise is divided into depots maintenance and field maintenance. The field maintenance are handled in each of the different 3 ketenas of transport service terminals which are located in Addis Ketma, Leghar, Menilik II Square . The field maintenance handles easy maintenance of the buses like changing & checking tire pressure. Simple check up and minor repair are also done on the kelas.

The depot maintenance are handled from three different centers located at Yeka, Shegole and Mekanisa depots. Major services given in the depots include Preventive maintenance & Scheduled Inspection. Each center handles both the scheduled preventive and breakdown maintenance of the buses boarding in the depots. The maintenance facilities gives service for the 462 DAF model buses and 64 Mercedes most of the later ones are out of service. The Yeka depots handles 249 buses of which 210 are DAF model and 19 are Mercedes, Shegole and Mekanisa handles 196 and 80 buses respectively.

The Yeka Depot being the biggest service centers constitute all body shop and Full garage service other than the depot maintenance service. This study is conducted specifically on this center.

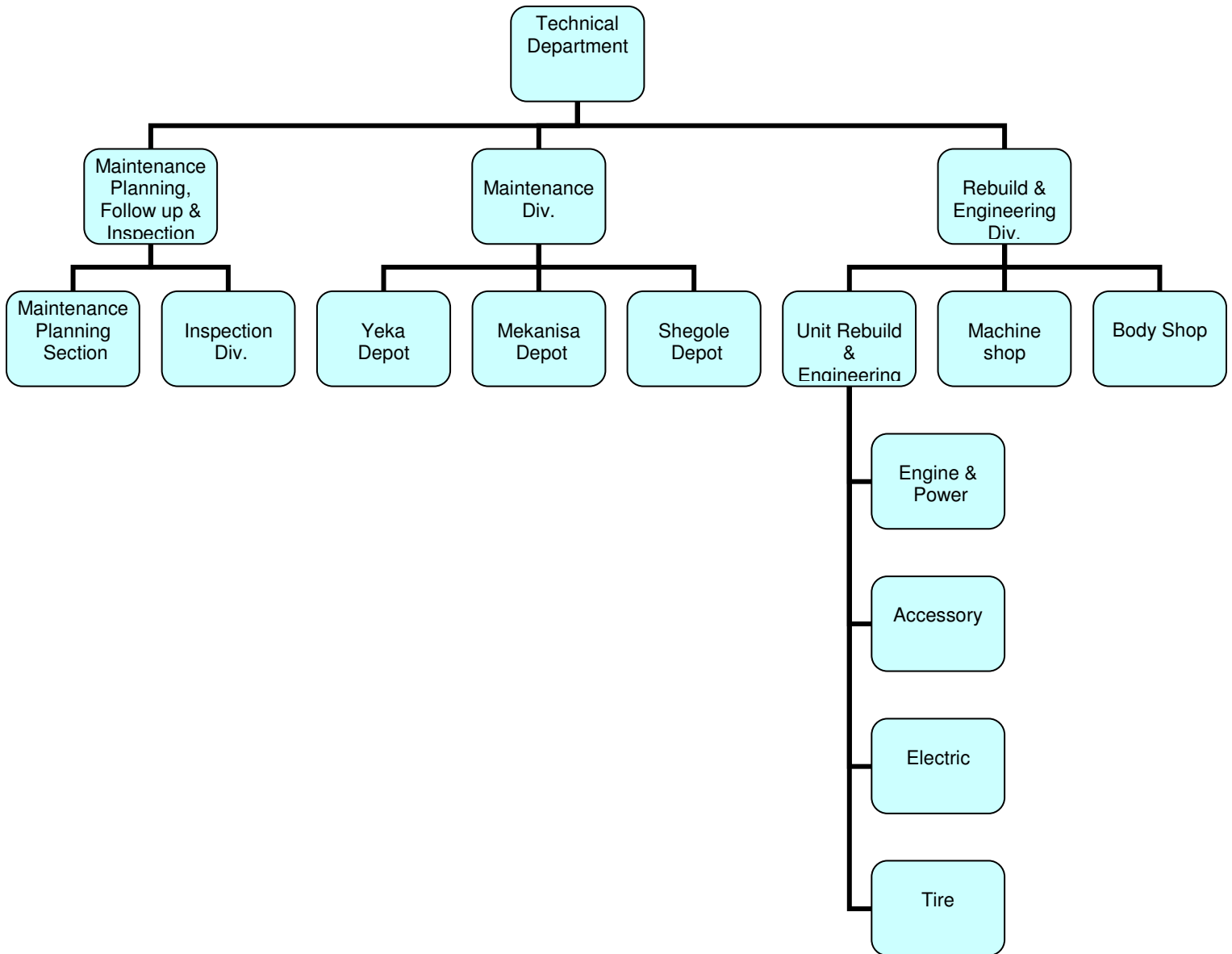

Figure 5-1. ACBSE Maintenance Organization

### **5.3. Types of Maintenance services**

The maintenance activities done on the Yeka maintenance facility are basically divided into preventive maintenance, corrective maintenance, breakdown maintenance and garage works. The preventive maintenance constitutes A, B and P type of services which are done based on the mileage traveled by each bus and/or time based schedule. A type service is done on every 10,000 km or every one month. The P type inspection is done every two weeks or 3000km mileage and B type services are done every 30000km or every three months and on the B type service the A type services are done simultaneously.

When the corrective tasks are done when buses enter to the system for preventive maintenance and inspection. Breakdown maintenances are based on their arrival to breakdown to the depots.

Unit rebuild and Engineering which is only operational on the Yeka depot handles accessories maintenance, engine overhaul and machine shop works. The garage has also its on body shop and tire maintenance.

The corrective maintenance are done based on the inspection and observations discovered when the buses enters for the preventive maintenance and inspection. And each of the buses are inspected after any preventive maintenance activity.

### 5.3 Maintenance Work Flow

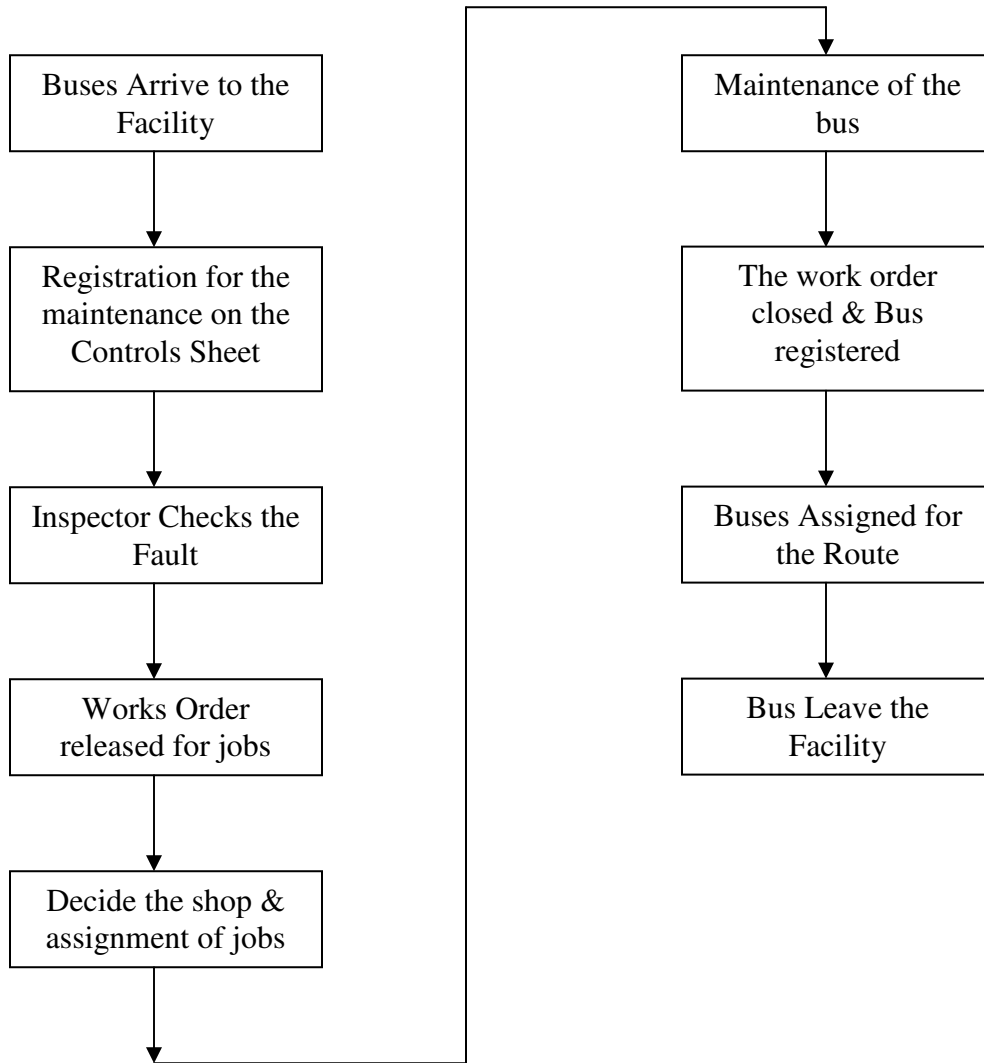

Figure 5-2 Maintenance work flow

## 6 Data Collection & Analysis

To analyze the maintenance system the necessary data are collected from the operation of the facility. First the overall capacity and type of the maintenance services is studied. And the number of buses entering the facility based on their program for PM services and those which comes for the breakdown maintenance their arrival pattern are analyzed.

The type and constitutions of the maintenance works done considering maintenance service times for each operations undertaken in different shops and service centers are studied from the weekly, monthly and annual performance report and practical observation of the system.

The maintenance facility works in two shifts for the Breakdown depot maintenance and PM maintenance section. But the garage and unit rebuild works in only one shift.

### 6.1 Facility Capacity

The overall capacity of the maintenance facility is determined by the number of technical staffs and the working spaces( bays) of the facility. The exiting maintenance facility with regards to the number of available flat and pit bays in each of the maintenance section are given below:

Depot Maintenance Section

- 8 Flat Bays
- 8 Pit Bays

PM Maintenance Section

- 6 Pit Bays
- 3 flat bays

Body shop

- 10 flat Bays
- 3 Pit Bays

Lavago

- 3 Bays

The garage which handles the unit maintenance and rebuild has engine shop, electric shop, accessory shop, body shop and tire shop.

The number of workers in the maintenance section of the Yeka depot maintenance center is given below

No.	Description	Qty
1.	Body Rebuild section	
	Welders	18
	Painters	4
	Carpenter	8
2.	Unit Maintenance section	
	Mechanics	30
	Machinist	4
	Auto electrician	8
	Tire maintainer	12
3.	Maintenance Division	
	Mechanic	66
	Auto electrician	12

**Table 6-1 Workers in Technical department**

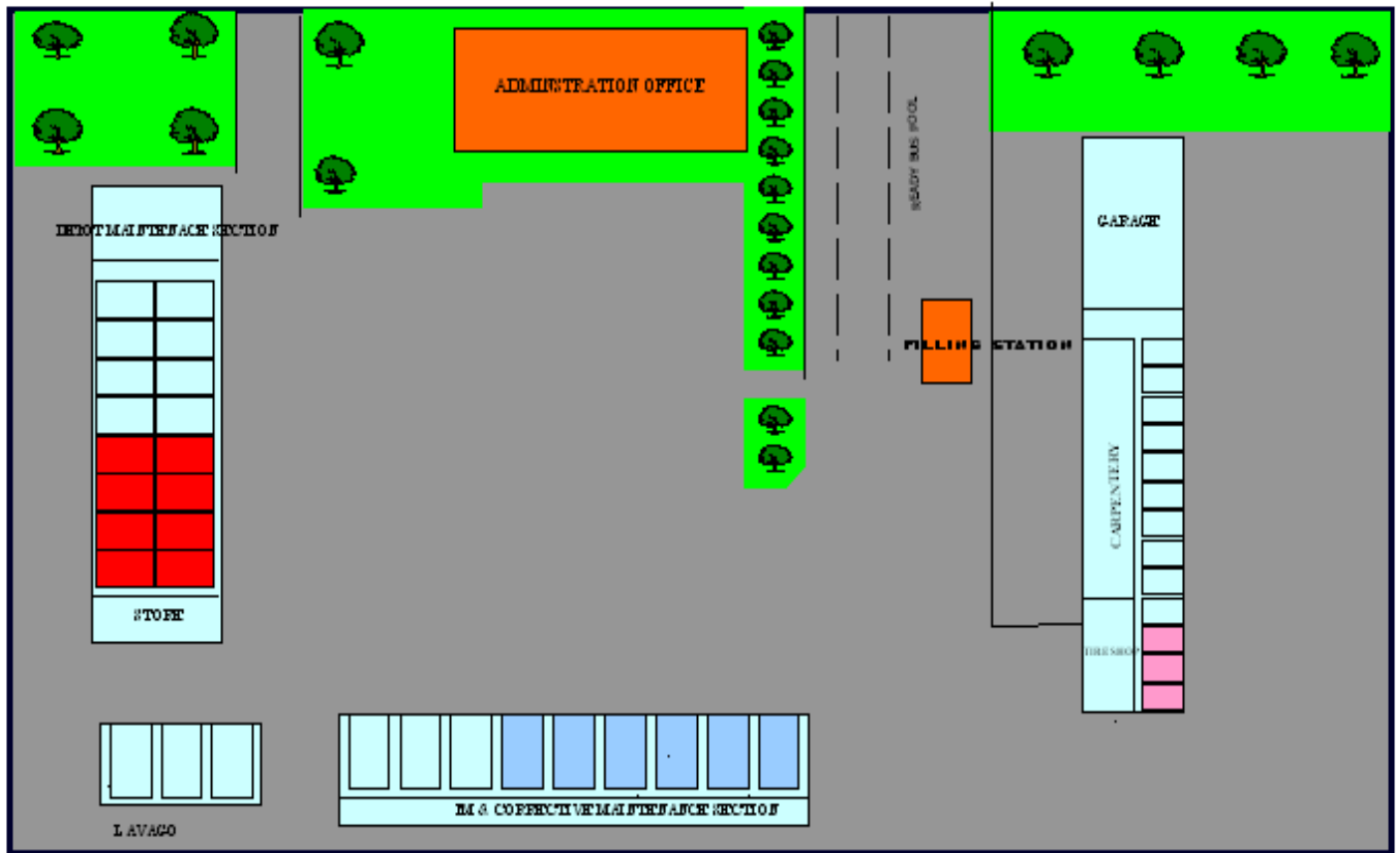

Figure 6-1 Yeka Depot Facility Layout

## 6.2 Bus Arrival Pattern

Buses enter to the facility for preventive and breakdown maintenances which are the arrivals entities to the simulation model. For the PM the arrival pattern is based on the schedule which takes the mileage of buses and schedule. Normally six buses enter for PM service every day.

Buses for breakdown maintenance enter the facility randomly in any time of the day. Based on the data collected from the control sheets the inter arrival time and theoretical statistical distributions is studied. The inter arrival time are given in the Annex 1.

### **6.3 Service Time**

The service time for the different maintenance operations have been taken from the monthly past performance records.

The actual duration time it takes for the tasks undertaken in each of the shops are studied with their constitution. Normally the maintenance tasks which is done on the depot taking less than five hours is taken as light maintenance and greater than five hours are classified as heavy maintenance.

Data is collected for the major maintenance tasks undertaken on the facility are the following given in the annex 1:

- ❖ *Breakdown Maintenance Time*
- ❖ *Preventive Maintenance Time*
- ❖ *Engine Maintenance time*
- ❖ *Accessories Maintenance Time*
- ❖ *Electric Maintenance Time*
- ❖ *Body Maintenance Time*
- ❖ *Tire Maintenance Time*

## 6.4 Distribution Fitting

The data collected both for arrival and service times are taken are fitted to the theoretical distributions to access random numbers to generate time periods from the distributions to run the simulation with the help of input analyzer tools installed in the Arena simulation package.

The different operations with their distributions fitted are given in the Annex 2 and summarized in table 1 below:

Type of Service	Distributions	Remark
Inter Arrival Time	EXPO( 12 )	( $\mu=12$ ,minutes)
Light Maintenance	NORM(1.33,0.685)	( $\mu=1.33$ , $\sigma^2=0.65$ , hours)
Heavy Maintenance	NORM(7.18, 1.55)	( $\mu=7.18$ , $\sigma^2=1.55$ , hours)
Preventive Maintenance time	NORM(5.04, 0.232)	( $\mu=5.04$ , $\sigma^2=0.232$ , hours)
Body Maint. time	18*BETA(0.471,3.22)	( $\alpha_1=0.471$ , $\alpha_2=3.22$ , hours)
Accessories Maint. time	0.99+EXPO(0.907)	( $\mu=.907$ ,hours)
Engine Shop time	1+LOGN(6.76,15.3)	( $\mu=6.76$ , $\sigma^2=15.3$ , hours)
Tire Shop time	CONT(0.3, 0.5, 1.0, 1)	( $\alpha=0.3,0.5,0.7,1$ )
Electric Shop time	0.99+19*BETA(0.861,2.35)	( $\alpha_1=0.861$ , $\alpha_2=2.35$ , hours)

**Table 6-2 Maintenance Service Distributions**

## **7 Simulation Model Development**

### **7.1 Model Formulation**

The model is developed based on the logic which is shown the figure 9 which shows the basic work flow of the activities in the maintenance facility. The buses enter the system based on stochastic distributions for breakdown maintenance and based on the schedule for PM and inspection.

In the PM module buses enters first to the cleaning station and goes to the PM pit for P,A,B type maintenance services. If there is any fault and problems it is directed to bays of the corrective maintenance while inspection otherwise live the facility. Buses coming to the facility for the breakdown maintenance are first maintained in the depot bays and if it requires garage work the components are given for the different shops in the garage.

The waiting cost of each bus is added on the model based on the average revenue generated in the normal operation of buses.

The overall work flow of the maintenance activities is given in the figure in 7-2.

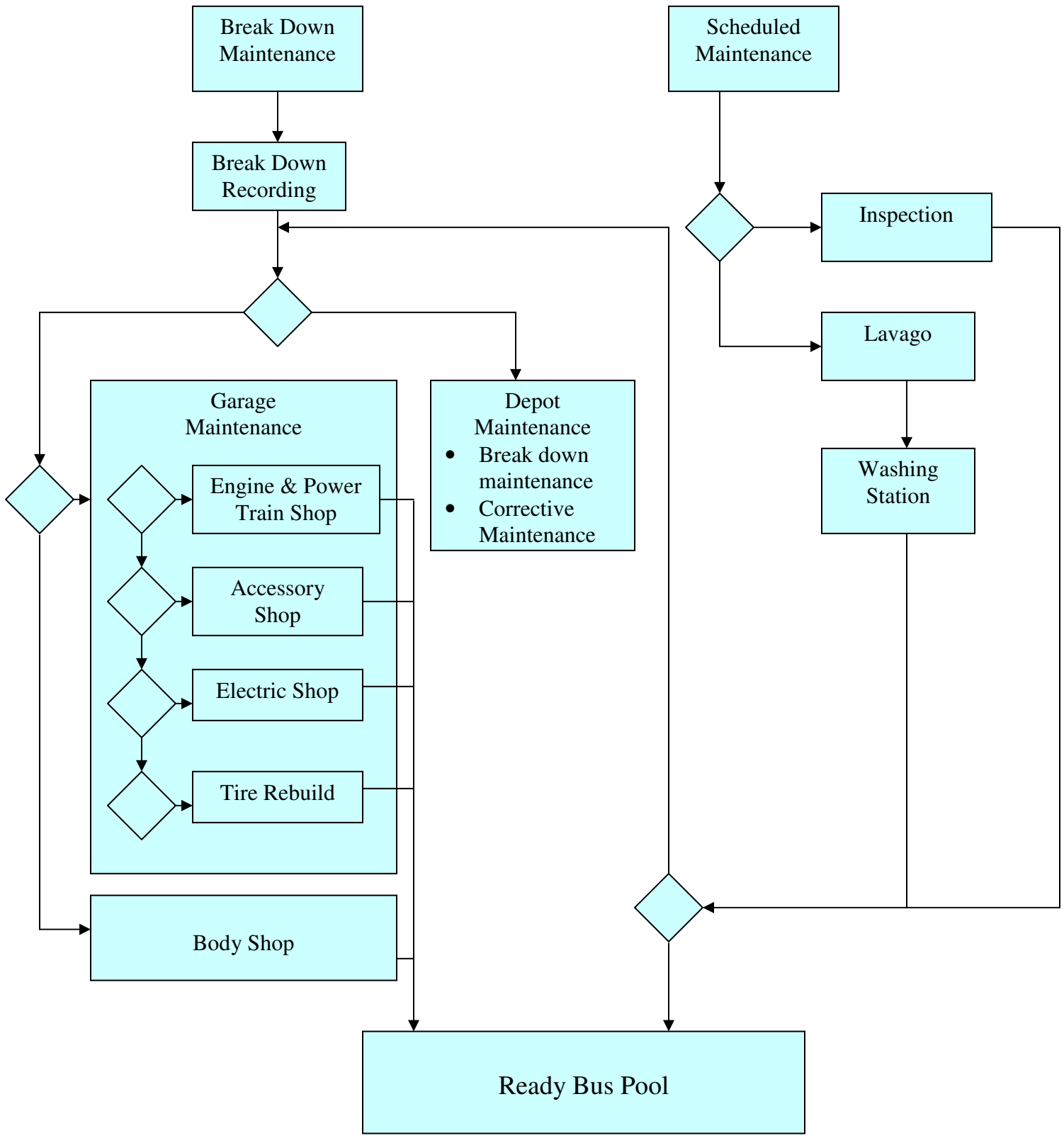

Figure 7-1 Maintenance Model Logic

**Process** [?] [X]

Name:  Type:

Logic

Action:  Priority:

Resources:

Delay Type:  Units:  Allocation:

Expression:

Report Statistics

Figure 7-2 Process data Entry Window

Resource - Basic Process			
	Name	Type	Capacity
1	Inspector1	Fixed Capacity	4
2	Flat BayD	Fixed Capacity	8
3	pit bayD	Fixed Capacity	8 <input type="text" value="4"/>
4	Engine shop	Based on Schedule	engine schedule
5	pool22	Fixed Capacity	1
6	Electric shop	Based on Schedule	electric shop s
7	AccessoriesShop	Based on Schedule	accessery schedule
8	tyreshop	Fixed Capacity	3
9	body shop	Based on Schedule	body schedule
10	inspect	Fixed Capacity	4
11	flatbay	Fixed Capacity	3
12	pitbay	Fixed Capacity	3
13	Lavago	Fixed Capacity	3
14	pool5	Fixed Capacity	1
15	pools	Fixed Capacity	1
16	Pit C	Fixed Capacity	3
17	spare pool	Fixed Capacity	1

Figure 7-3 Resources

## 7.2 Model Description

The model is developed with the help of basic and advanced modules built in the Arena simulation package. The input data are entered on each of the modules. The maintenance activities for the inspection, breakdown maintenance, corrective maintenance and garage maintenance have their own sub model which contains the detail of their activities.

The data collected and the fitted distributions are then entered on the model as it shown in the figure 12. And each of the data regarding each shops are also built on the model.

The model is then simulated for the one month period of time with four different replications taken for each case. And at last different reports are generated based the performance report

The animation of the model is at last modeled with the help route paths and queuing in each of working bays on the maintenance facility.

# Model Logic

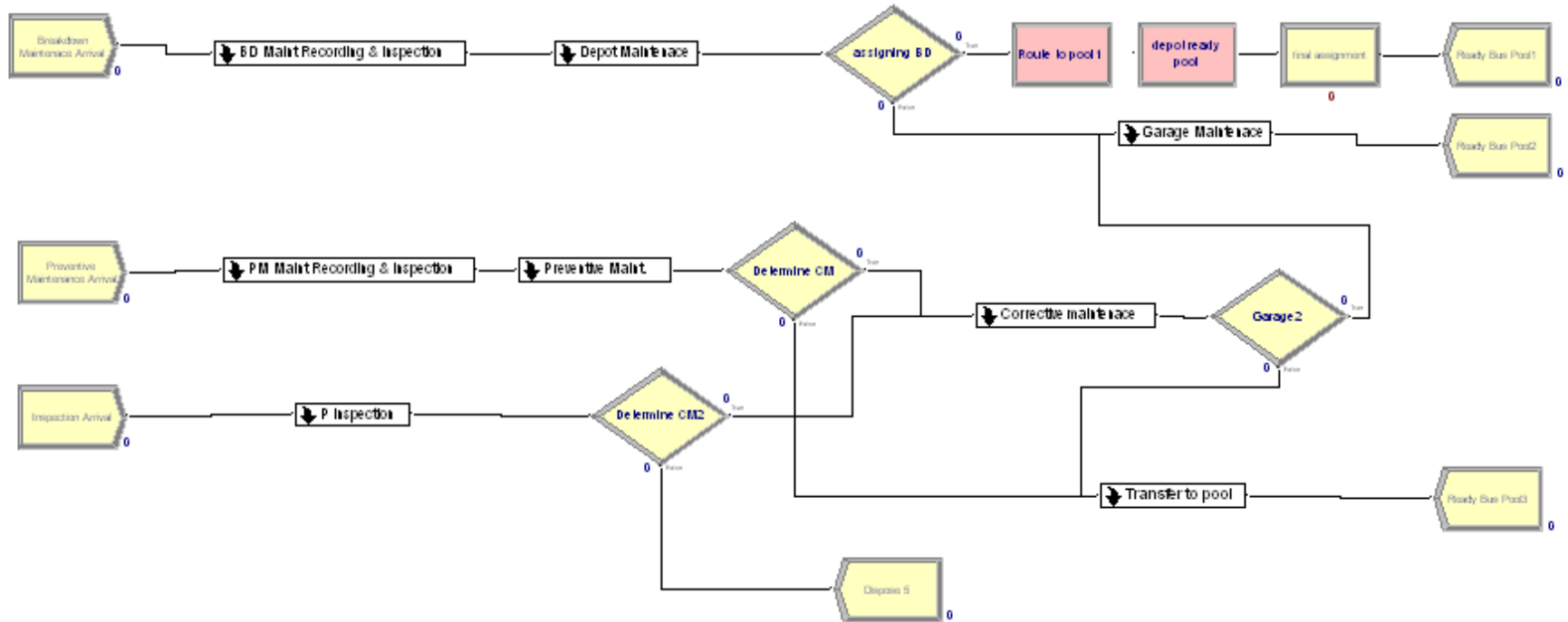
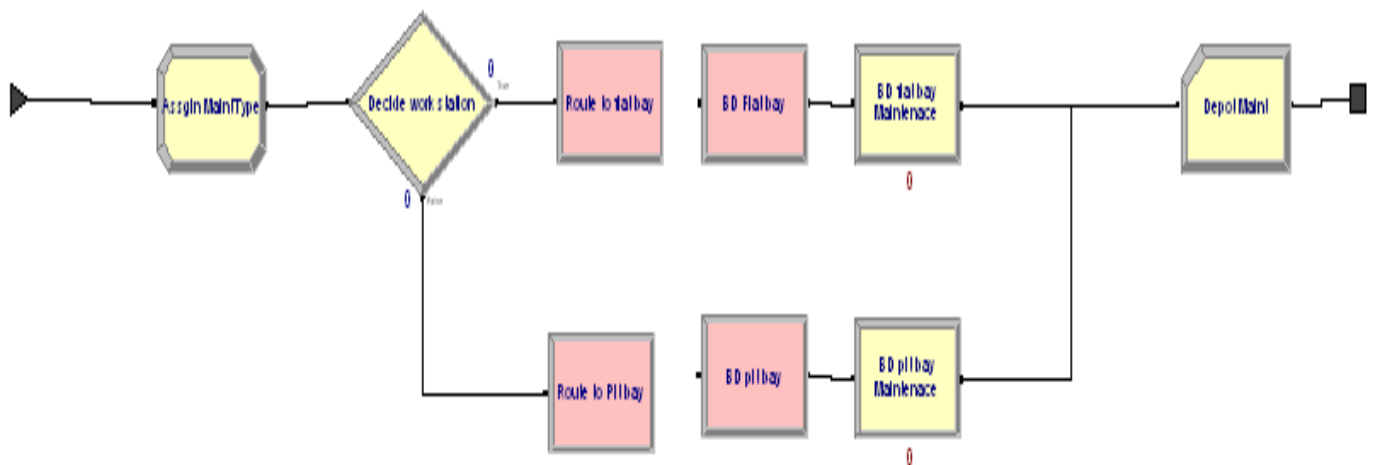

Figure 7-4 Model logic

As shown in the figure 7-3 the buses enter to the system from three create modules for each of breakdown, PM Service and P inspection. The buses which enter the facility are first recorded for their arrival time and the scope of the maintenance is inspected first in the case of breakdown maintenance. The breakdown maintenance inter arrival is exponential with mean of 12 minutes and six buses are scheduled for preventive maintenance each day.

In the depot sub model which constitutes the breakdown maintenance first the entering bus maintenance time attribute is assigned in the assign module. And the maintenance bays for the pit and flat bay decided with the decision module where 60% of the bus going to the pit bays. A router module is also used to route each buses to the stations. The bus undergoes the maintenance in each of the bays based on their maintenance time given on the table 6-2 and at last the number of bus maintained in the depot is recorded through the record module.



**Figure 7-5** Depot maintenance sub model

In the preventive maintenance sub model buses which comes for the preventive maintenance to the facility goes the washing station for cleaning and routed to three pit bays. The time is assigned at the assign module based on the distribution given in table 6-2. The time for completing maintenance of Buses is also recorded for the analysis.

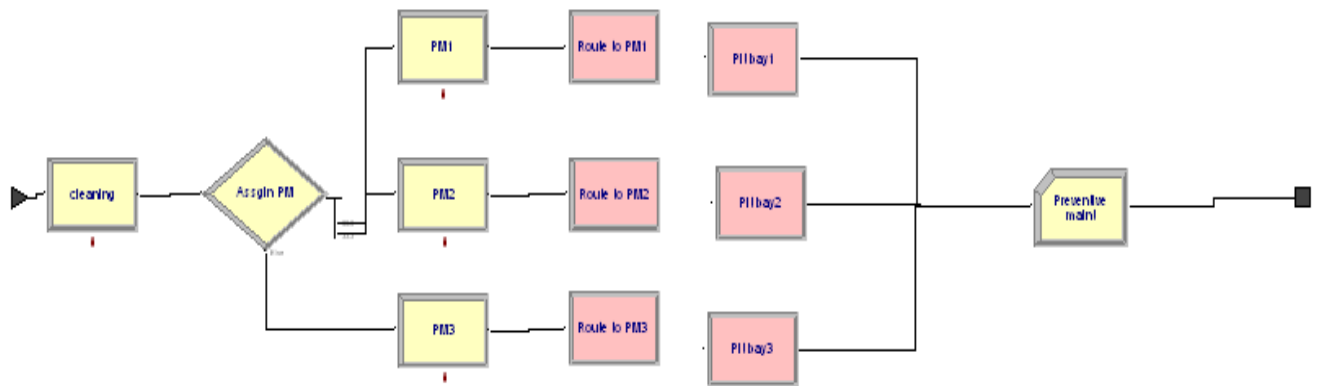

**Figure 7-5** Preventive Maintenance *PM Sub model*

Buses which comes both for PM and inspection every day also goes to the corrective maintenance bays when theirs is any the faults discovered to be corrected. In the corrective maintenance module (Fig7-5) buses first assigned their maintenance delay and routed for the flat and pit bays. At last the time taken for the maintenance is also recorded.

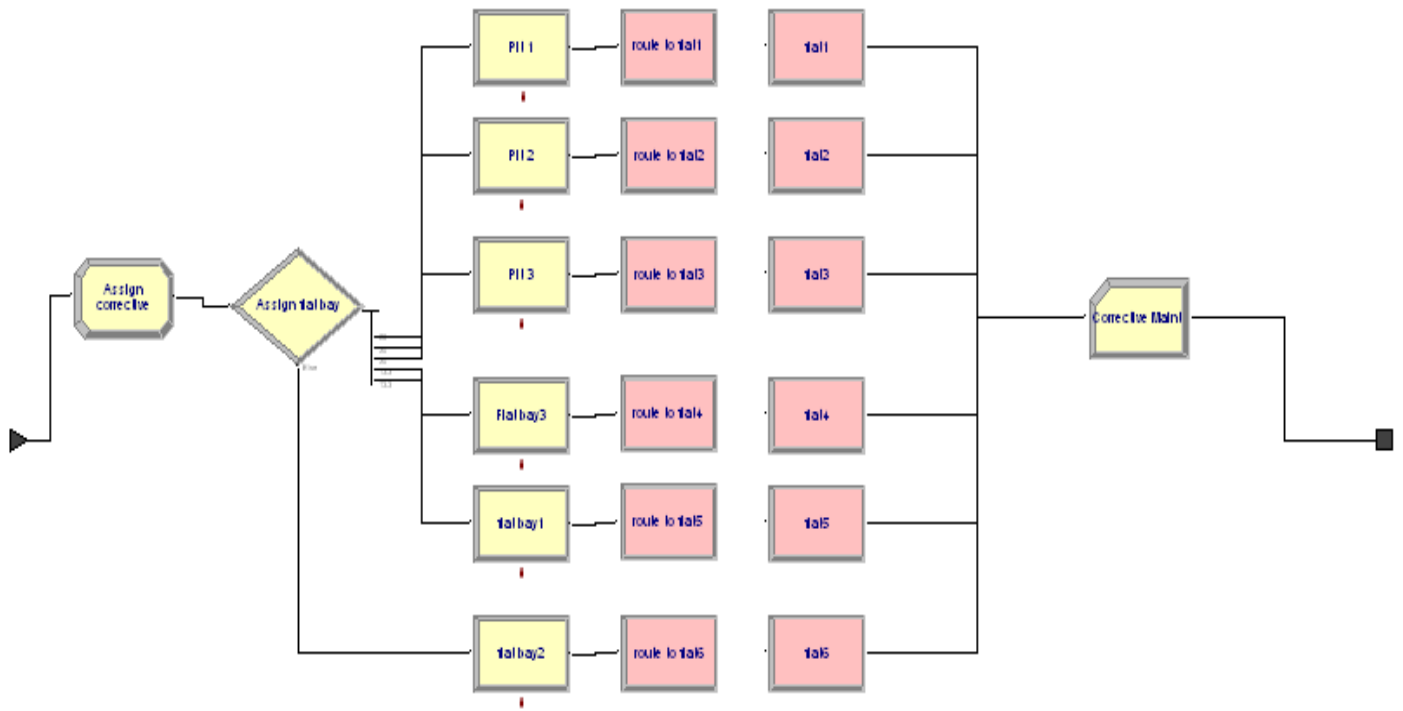

**Figure 7-6** *Corrective maintenance sub model*

Buses which come for the garage maintenance are first routed to the garage maintenance shop. The shop includes the engine shop, electric shop, accessory shop, body shop and tire shop. The constitution of each maintenance in each shop is given in the **Table 7-1** .

**Table 7-1 Garage maintenance shops constitution**

	Percentage	Distributions	Maintenance time
Engine	4%	1+LOGN(6.76,15.3)	( $\mu=6.76, \sigma^2=15.3$ , hours)
Electric	9%	0.99+19*BETA(0.861,2.35)	( $\alpha_1=0.861, \alpha_2=2.35$ , hours)
Accessory	41%	0.99+EXPO(0.907)	( $\mu=.907$ ,hours)
Tire	37%	CONT(0.3, 0.5, 1.0, 1)	( $\alpha=0.3,0.5,0.7,1$ )
Body	9%	18*BETA(0.471,3.22)	( $\alpha_1=0.471, \alpha_2=3.22$ , hours)

The maintenance time for each of the maintenance shop is assigned in the process module. When the buses leave the garage the time taken for the maintenance is recorded in the record module. In the garage section the delays due to spare parts are added in this sub module.

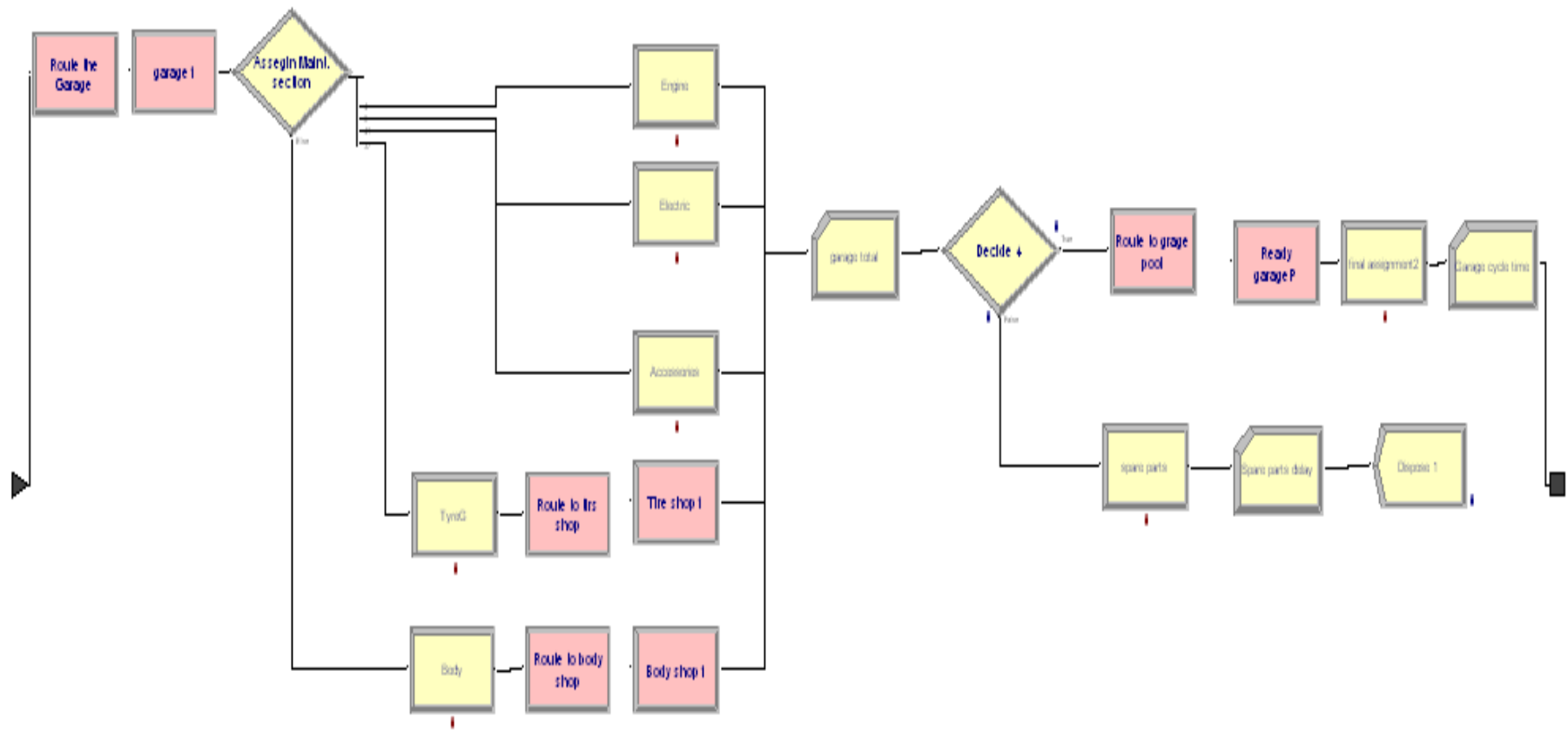

Figure 7-7 Garage sub model

May 24, 2008  
06:00:00

# ANBESSA MAINTENANCE FACILITY

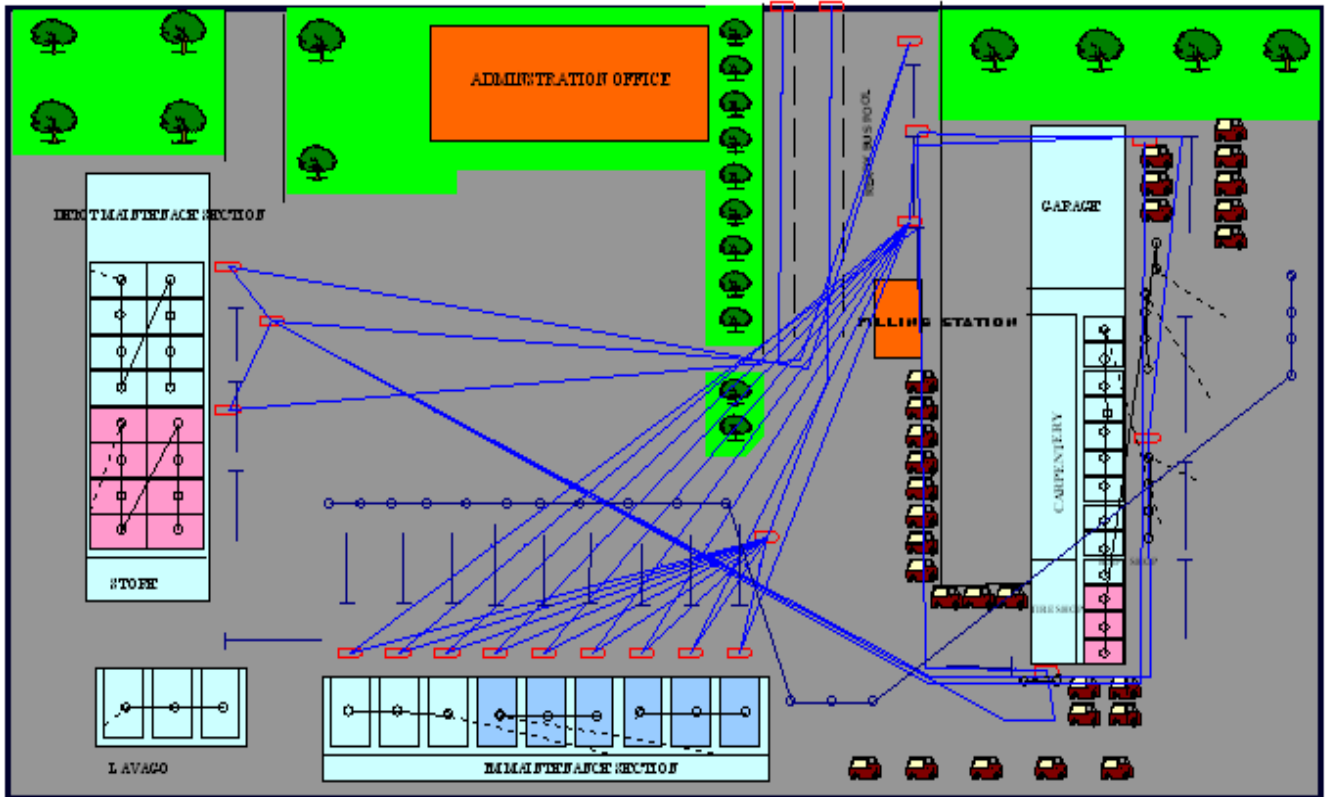

Figure 7-8 Animation Window

### 7.3 Simulation Setup

The simulation model is designed to run for 16 working hours for each day of operation for one month period of time with four replications taken for each simulation runs.

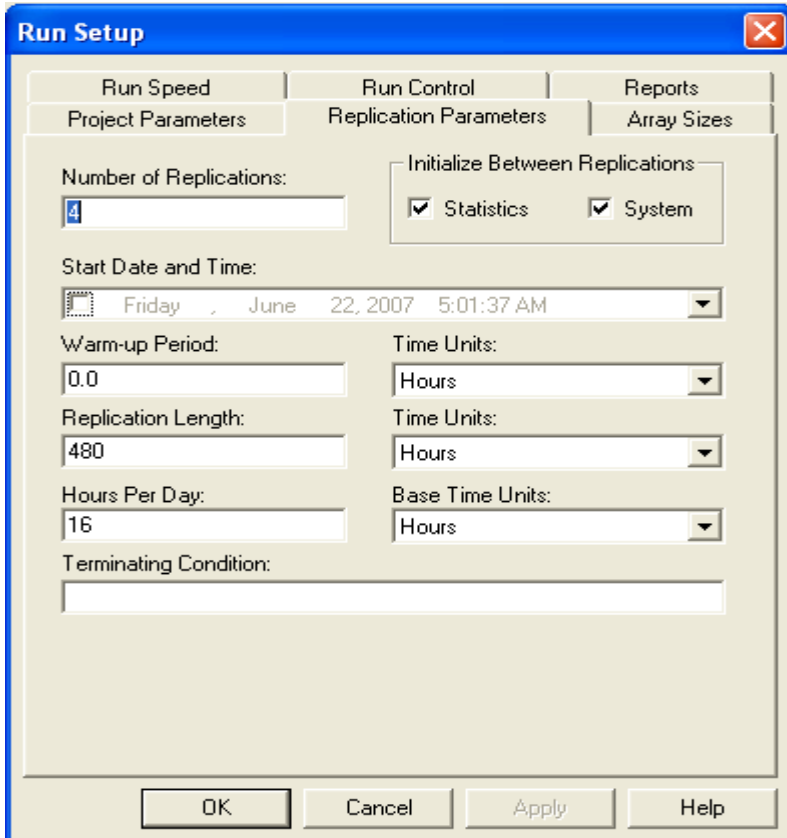

Figure 7-9 Simulation Setup

## 8 Simulation Result

The model is simulated for one month period of time for four replication with Arena and the result generated are presented in this section of the document.

To study the performance of the existing maintenance facility parameters like weighting time, throughput, utilization location and cycle times are considered for the analysis.

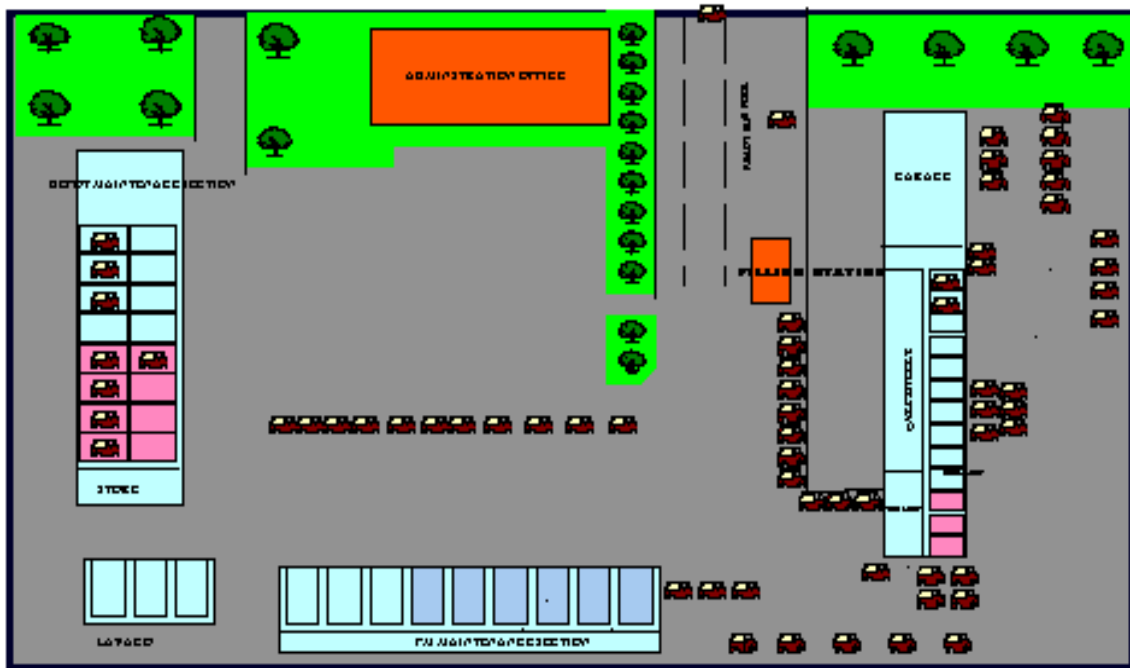

Figure 8-1 Animation of the facility

### 8.1 Cycle Time

The average cycle time for each type of maintenance in different shops are recorded from the simulation runs and are given on the table 8-1. As it is shown on the table the longest cycle time is the one which buses have queued for spare parts on the garage.

**Table 8-1 Cycle time for the existing facility**

Type	Average(Hr)
Corrective Main.	2.69
Depot Main.	2.12
Preventive Main.	8.83
Garage Cycle Time	4.25
Spare Parts	259

## 8.2 Waiting Time & Queuing Length

The average waiting time and queuing lengths in each of the bays and shops for one month simulation period are given in the table 8-2.

**Table 8-2 Waiting time & length**

	Average Waiting time (Hr.)	Avg. Queuing length(Hrs)	Average Maint. Time(Hrs.)
Depot Flat bay	0.020	0.0399	1.90
Depot Pit bay	0.30	0.92	1.97
Accessories shop	3.18	5.62	1.89
Body shop	2.38	0.945	2.02
Electric shop	0.51	0.21	5.97
Engine shop	2.20	0.36	7.63
Tire shop	0.025	0.04	0.6
CR Flat bay1	0.39	0.05	1.85
CR Flat bay2	0.39	0.06	1.72
CR Flat bay3	0.46	0.06	1.75
CR Pit bay 1	0.96	0.18	2.01
CR Pit bay 2	1.00	0.17	1.98
CR Pit bay 3	1.03	0.17	1.81
PM pit bay 1	2.01	0.21	5.03
PM pit bay 2	1.92	0.20	5.05
PM pit bay 3	2.05	0.23	5.02
Spare Parts	183	11.77	240

As per the result data the greatest average waiting time of 169 hrs and queue length of 11 are for bus waiting for spare parts. The other long average waiting time and queue length is seen in the electric shop and accessory shops in the increasing order respectively.

The total waiting cost in the system per month is 263,066 birr.

### 8.3 Total Bus maintained in each shop

The number of buses which have entered into the system during the simulated one month span of time are :

- Breakdown Maintenance -2379 buses
- Preventive Maintenance -186 buses
- Inspection-434 buses

Buses which have got services for each type of maintenances and in the different shops are summarized in the table 8.3.

**Table 8-3** *Number of bus maintained in one month*

	Number of bus Maintained /month
Total Bus maintained	2935
Depot Flat bay	941
Depot Pit bay	1437
Accessories shop	845
Body shop	190
Electric shop	189
Engine shop	83
Tire shop	780
Corrective Flat bay	190
Corrective Pit bay	308
PM Pit bay	180

The break down maintenance in each flat and pit bays of depot constitutes the major part of the maintenance. For the unit build section the accessories maintenance takes the largest share.

## 8.4 Location Utilization

The overall location utilization of each bays in the different shops after the model has run for the simulated time is shown in the table 8-4.

**Table 8-4 Location Utilization**

	Percentage(%)
Depot Flat bay	0.53
Depot Pit bay	0.68
Body	0.16
Corrective Flat bay	0.27
Corrective Pit bay	0.39
PM Pit	0.64
Washing station	0.12

The washing station and Body shop bays have the least location utilization which have excess capacities on the layouts. Normally the body shop works for one shift and has 13 bays. The washing station is utilized at night only when buses enter for the preventive maintenance the next days take full cleaning service. And generally the utilization level of the bays are low.

## **9 Developing Scenarios**

In the pervious section the facility's maintenance activities have been modeled and simulated for four replications. Accordingly the observed performance of the exiting facility is evaluated based on different operations.

Hence to improve the performance the facility different scenarios are developed to see how the system works for changes in the some of the operating parameters.

For the exiting facility model developed a different scenarios are considered for the analysis which are:

Scenario1 - Adding new employee

Scenario2 - Solving the spare parts problem

Scenario3 - Rearranging the layout

For each scenarios the benefits which will be gained and the costs associated with the implementation is analyzed from the respective simulation runs.

### **9.1 Scenario 1 -Adding new Employees**

The garage division for the unit maintenance and rebuild was considered to see the effects of adding employees to the section. This division has shortage of employees in the accessory shop and electric shop. The scenario is developed by adding four employees one crew for each of accessory, and electric shops.

The improvements achieved from adding employee is studied with its benefits and associated cost.

### 9.1.1 Benefits

The direct benefits which will be gained from adding one crew for each of the accessory and electric shops are studied from separate simulation runs and are presented in the table 9-1 below for month .

**Table 9-1 Results of Scenario 1 for one month**

	Existing system	Scenario -1
Total Buses Maintained	2935	2964
Total Weighting cost(birr/ month)	263,066	250,943
Garage Cycle time(Hr.)	4.25	4.09
Accessory Weighting Time(Hr.)	3.18	2.98
Electric Weighting Time(Hr.)	0.51	0.17

### 9.1.2 Cost

The cost associated with scenario -1 involves hiring staffs. The estimated cost involved for the scenario 1 of hiring four mechanics for the garage of the maintenance facility is estimated based on the assumed monthly of 800 birr per month is 3200 birr per month.

The direct net saving from adding employees are given the table below

**Table 9-2 Net savings from Adding employee**

Expense per month	3,200 birr
Savings per month	12,123 birr
Net savings	8,923 birr

Hence it is advised to hire new mechanics for the accessory, and electric shops.

## 9.2 Senario2 -Without Spare part problem

Before analyzing the buses which queue every day to different spare parts the causes for buses which have stopped for long period are studied.

Many buses normally stopped in the maintenance facility due to the shortage of major spare parts which are imported from abroad. More than twenty buses are stopped in the Yeka depot due to major failures in the engine components in the garage. Some of the causes of for the stoppage and the number of bus stopped for long period of time due to spare parts are:

1. Connecting Rod & Con rod bearing – 5 Buses
2. Engine Block – 7 Buses
3. Engine stacked- 4 Buses
4. Crank shaft- 7 Buses
5. Main Bearing – 2 Buses

To see the benefits which can be achieved by purchasing the spare parts above a cost analysis was done. The estimated costs of the major spare parts for which the bus stopped for long period of time are:

**Table 9-3 Major Spare part costs**

No.	Description	Qty	Unit cost	Total(birr)
1.	Connecting Rod & con rod bearing	5	11,200.00	56,000.00
2.	Engine Block	7	178,280.00	1,247,960
3.	Crank shaft	7	71,820.00	498,960.00
4.	Main Bearing	2	4,000.00	8,000.00
Total				1,810,920

Hence purchasing the spare parts for the 21 buses which have stopped due to major engine components costs 1,810,920 birr.

The estimated average revenue for the buses per each day is 500 birr. Hence the total revenue for one year for the 21 buses decreasing the provision for Over Head and Fuel & lubricants cost is given by:

$$\begin{aligned} \text{Revenue} &= \text{Revenue per day} * \text{number of buses} * \text{no days per year.} \\ &= 0.15 * 21 * 30 * 12 * 500 = 567,000 \text{ birr per year.} \end{aligned}$$

Therefore the internal rate of Return(IRR) for purchasing those spare parts is calculated for five years.

$$1810920 = \frac{567000}{(1+i)^1} + \frac{567000}{(1+i)^2} + \frac{567000}{(1+i)^3} + \frac{567000}{(1+i)^4} + \frac{567000}{(1+i)^5}$$

Where i is internal rate of return

From solving the above equation the internal rate of return is equal to 17.1

Therefore it is better for the enterprise to buy those major spare parts and make buses operational.

### 9.2.1 Scenario -2

The second scenario is developed to see the improvements in major performance parameters if the problems in the shortage of spares parts avoided in the every day operations.

But the major causes for buses redundant stoppage are due to tire inner tubes, tire, tip top, pinion gears, pressure plates, rivets, kits, seals. The costs of these common spare parts are:

1. Tire with inner tube -5000 birr
2. Pressure plate -2800 birr
3. Pinion Gear -1000 birr
4. Repair kits - 5,000 birr
5. Radiator seal - 500 birr
6. Other small items

The model developed is simulated with out spare parts stoppage in the every day operation assuming enough inventories of the spare parts. In the existing system, normally an average of eleven buses queue in the system due to shortage of different components. Therefore the second scenario is modeled by making all the buses which comes to the garage to live the facility after their maintenance without any queue requirements.

The benefits achieved from this scenario for the overall systems are shown in the table below.

**Table 9-4 Results of scenario 2 for one month**

	Exiting system	Scenario -2
Total Bus Maintained	2902	2989
Total Weighting cost	263,066birr	229,149 birr
Weighting time per bus(Hrs.)	2.04	1.91

The net savings per month for having sufficient spare parts inventory is hence 33,917 birr.

### 9.2.2 Cost

To solve the problems in the queuing of buses due to spare parts shortage it required building efficient inventory system and shorten the material procurement process. Other than those improvements sufficient budget should be assigned for the purchase of spare parts.

The advantages which can be gained for assigning one million extra budget for spare parts and its internal rate of return is analyzed for four years.

The saving per year =12\*33917=407,004 birr

The rate of return is calculated from

$$1000000 = \frac{407004}{(1+i)^1} + \frac{407004}{(1+i)^2} + \frac{407004}{(1+i)^3} + \frac{407004}{(1+i)^4}$$

The internal rate of return is found to be 22.5% evaluated for four years. Therefore it is better to buy and keep some of fast moving spare parts in the facility.

### **9.3 Scenario 3- With Rearranged Layout**

Bus sometimes queue for waiting pits in the depot maintenance section and hence a scenario is developed for assessing the usage of corrective maintenance pits with modified layout.

On the exiting facility layout the improvement which can be found by arranging one of corrective maintenance pit bays for breakdown maintenance is analyzed which will increase the number of pit bays from eight to nine.

Implementing this scenario does not normally requires any further investment in the facility operating within the resource available. The modified layout is given in the figure 17 below.

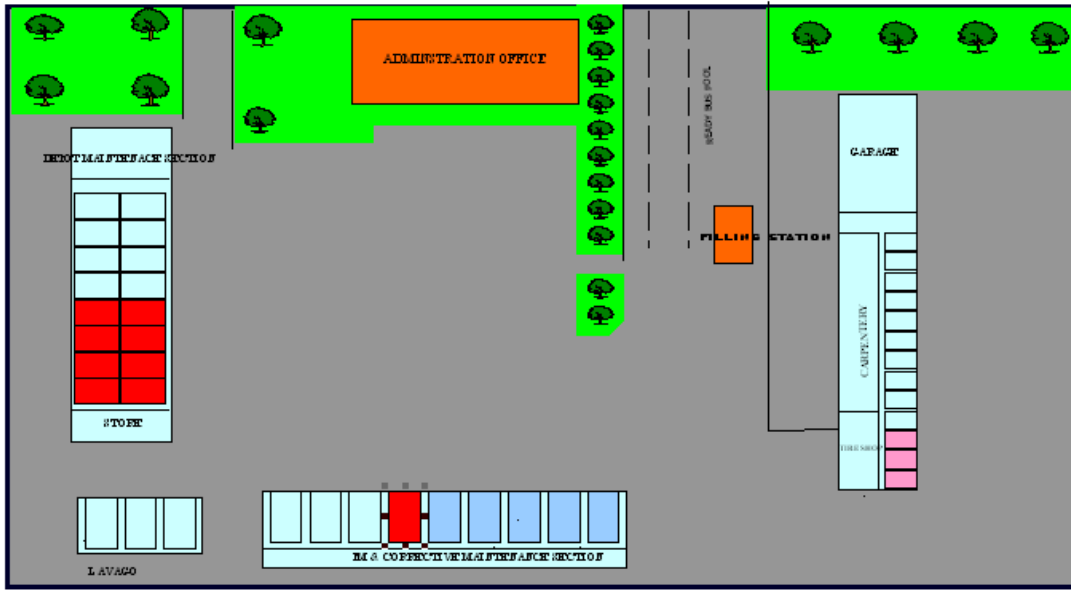

  
 Corrective pit

**Figure 9-1 Modified layout**

The benefits with this modified layout are given the table below

	Existing system	Scenario -3
Total Bus Maintained	2935	2947
Total Weighting cost(birr/month)	263,066	249,320
Depot maintenance Cycle time(Hr.)	2.13	1.98
Depot Pit weighting time (Hr.)	0.30	0.12

**Table 9-5 Result of scenario -3**

This scenario does not involve any extra cost but to use the maintenance pit bay from the preventive maintenance section but a monthly saving of 13,746 birr can be achieved by rearranging the work stations.

## **Part 3 Conclusions and Recommendations**

### **10 Conclusions**

Generally the dynamic stochastic models have to be practiced in the facility design before making any major investments on new asset and rearranging the existing system. And hence the simulation can play a great role in the layout design procedures and proved that a good tool in the engineering assessment.

The study has succeeded in modeling the maintenance facility of Anbessa City Bus Service Enterprise and simulate the model to evaluate its performance through different parameters.

The study has also shown the major problems in the facility. And as per the analysis the shortage of spare parts and unmatched number of employee with demand in some of the maintenance workshops are the major causes for the poor service level.

To see the rooms for improvements on the exiting facility different scenarios have been developed and studied. From the analysis it is showed that a better improvement in cost saving can be achieved by rearranging the facility layout, hiring staffs and solving the spare parts problems. The simulation study result has also showed that the body shop has excess capacities which can be used for giving services for external customers.

## 11 Recommendations

Based on the study and analysis the following recommendations are forwarded

- More than 40 DAF model buses are stopped for long period of time due to major engine failures and loss of spare parts and hence the enterprise must solve those spare part problems to improve the services it deliver to the public.
- The enterprise should also provide sufficient budget for the fast moving spare parts which directly affect the overall performance of the enterprise.
- The purchasing procedure which is now used for the procurement of spare parts must be shortened to give urgent response for the items required by the maintenance section.
- To decrease the delays in the facility for the maintenance service the right number of staffs must be employed.
- Improving the motivation level of the employees to increase the maintenance service qualities and avoid redundant maintenance failures.
- The body shop has excess capacity in both physical and number of staffs in the shop which can be used for giving services for external customers.
- A dynamic stochastic analysis must be promoted in the area of many engineering problems to see the real behaviours of a system.
- Further research is also recommended in the area of combining generic algorithm with simulation in the facility layout design procedures.

## References

1. Richard L. Fransis, Leon F. McGinnis, John A. White, (2002), *Facility layout and location an analytical approach*, second edition, Prentice Hall.
2. James Moore, (1962), *Plant layout & design*, Macmillan, New York.
3. Fred E. Meyers, Matthew P. Stephens, *Manufacturing Facilities Desgin and Material Handling*, third edition, Prentice Hall.
4. S.C. Sharma, (2003), *Plant layout and material handling*, Khanna publishers.
5. Hales, H.L., (1984) *Computer Aided Facilities Planning*, Marcel Dekker, Inc., New York.
6. Daniel Kitaw,(1994), *Industrial Management and Engineering Economy*.
7. Averill M. Law& W. David Kelton, *Simulation Modeling and Analysis*, Tata McGraw hills.
8. Kelton Sadowski Sturrock ,*Simulation with Arena*, McGraw Hill Fourth edition, New York.
9. Christopher A. Chung, (2004), *Simulation Modeling Hand book A Pactical approach*, CRC Press, Taylor & Francis Group,LLC

10. Adedeji B. Badiru, (2006), Hand book of Industrial and System Engineering, CRC Press, Taylor & Francis Group, LLC.
11. Vaugehan Hetem, “Integrating Capacity Simulation Planning”, PP.1470-1472 , Proceeding of winter simulation conference, 2001
12. Esera. A. Alisa & Li Lin, (2005), “For Effective Layout Planning: Optimization and simulation”, Proceeding of Winter simulation Conference, 2005

## Annex 1 (Distribution Fitting)

### 1. Breakdown Inter arrival Time

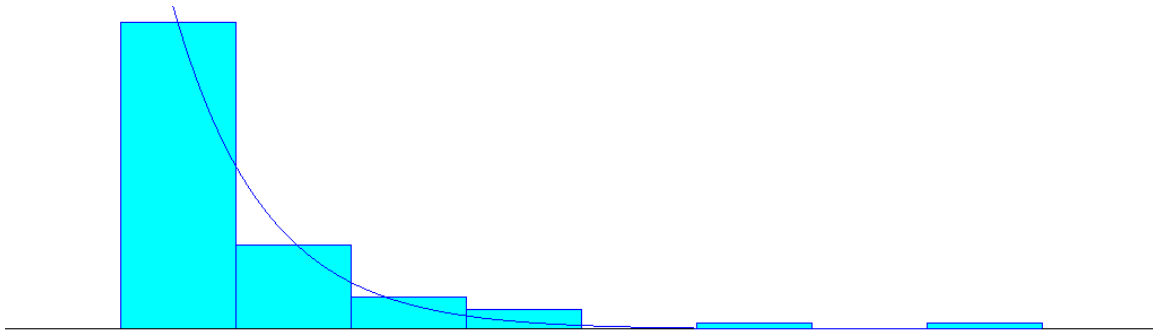

#### Distribution Summary

Distribution: Exponential

Expression:  $-0.001 + \text{EXPO}(12)$

Square Error: 0.003354

#### Chi Square Test

Number of intervals = 2

Degrees of freedom = 0

Test Statistic = 0.726

Corresponding p-value < 0.005

#### Kolmogorov-Smirnov Test

Test Statistic = 0.145

Corresponding p-value = 0.0971

#### Data Summary

Number of Data Points = 70

Min Data Value = 0

Max Data Value = 120

Sample Mean = 12

Sample Std Dev = 20.7

#### Histogram Summary

Histogram Range = -0.001 to 120

Number of Intervals = 8

## 2. Heavy Maintenance Time

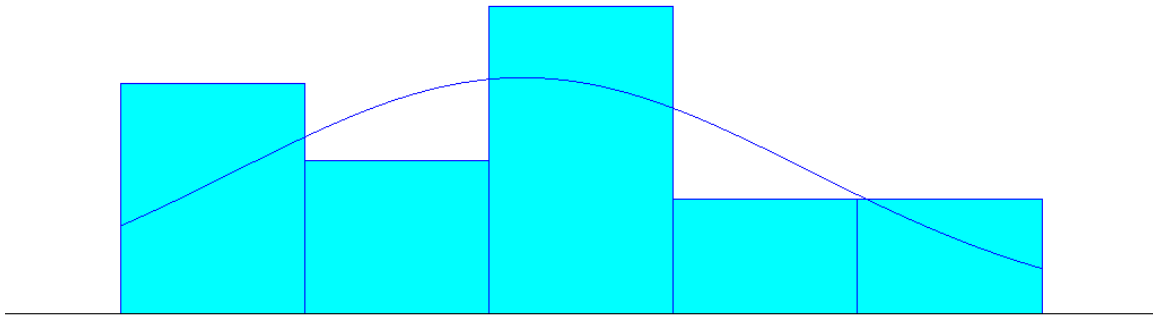

### Distribution Summary

Distribution: Normal

Expression:  $\text{NORM}(7.18, 1.55)$

Square Error: 0.027114

### Chi Square Test

Number of intervals = 3

Degrees of freedom = 0

Test Statistic = 0.858

Corresponding p-value < 0.005

### Kolmogorov-Smirnov Test

Test Statistic = 0.17

Corresponding p-value > 0.15

### Data Summary

Number of Data Points = 24

Min Data Value = 5

Max Data Value = 9.7

Sample Mean = 7.18

Sample Std Dev = 1.59

### Histogram Summary

Histogram Range = 5 to 10

Number of Intervals = 5

### 3. Light Maintenance Time

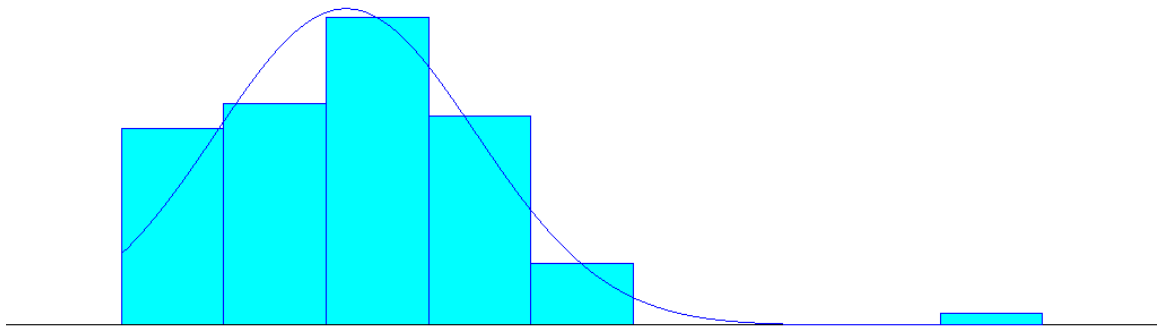

#### Distribution Summary

Distribution: Normal  
Expression:  $NORM(1.33, .685)$   
Square Error: 0.007015

#### Chi Square Test

Number of intervals = 4  
Degrees of freedom = 1  
Test Statistic = 3.49  
Corresponding p-value = 0.0656

#### Kolmogorov-Smirnov Test

Test Statistic = 0.134  
Corresponding p-value = 0.0976

#### Data Summary

Number of Data Points = 82  
Min Data Value = 0.6  
Max Data Value = 5  
Sample Mean = 1.33  
Sample Std Dev = 0.689

#### Histogram Summary

Histogram Range = 0.15 to 5  
Number of Intervals = 9

#### 4. Preventive Maintenance Time

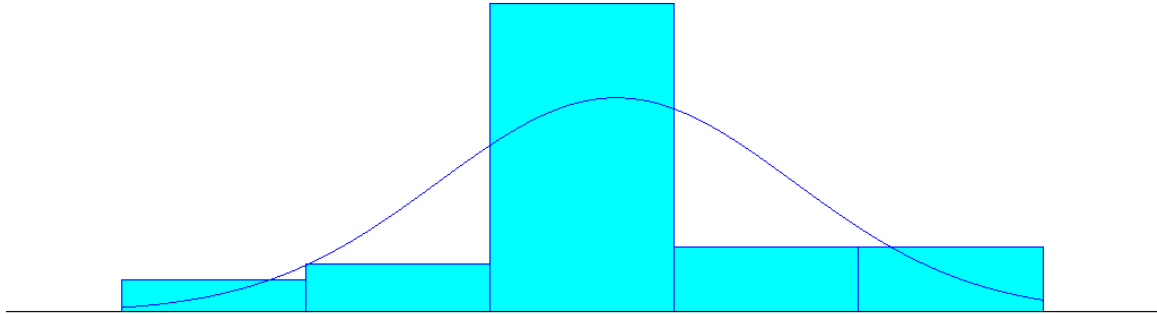

##### Distribution Summary

Distribution: Normal

Expression:  $NORM(5.04, .232)$

Square Error: 0.081406

##### Chi Square Test

Number of intervals = 3

Degrees of freedom = 0

Test Statistic = 8.33

Corresponding p-value < 0.005

##### Kolmogorov-Smirnov Test

Test Statistic = 0.237

Corresponding p-value = 0.0465

##### Data Summary

Number of Data Points = 32

Min Data Value = 4.5

Max Data Value = 5.5

Sample Mean = 5.04

Sample Std Dev = 0.235

##### Histogram Summary

Histogram Range = 4.4 to 5.6

Number of Intervals = 5

## 5. Engine Maintenance time

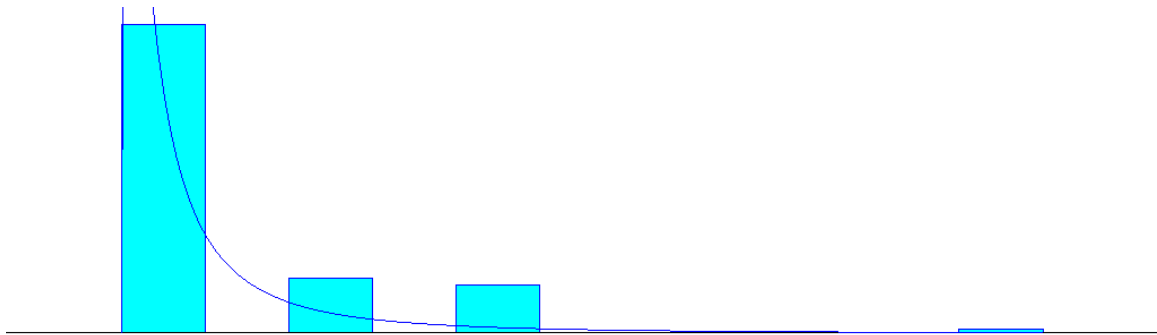

### Distribution Summary

Distribution: Lognormal

Expression:  $1 + \text{LOGN}(6.76, 15.3)$

Square Error: 0.035984

### Chi Square Test

Number of intervals = 3

Degrees of freedom = 0

Test Statistic = 73.4

Corresponding p-value < 0.005

### Kolmogorov-Smirnov Test

Test Statistic = 0.144

Corresponding p-value = 0.0121

### Data Summary

Number of Data Points = 121

Min Data Value = 1.65

Max Data Value = 74

Sample Mean = 8.17

Sample Std Dev = 11

### Histogram Summary

Histogram Range = 1 to 74

Number of Intervals = 11

## 6. Body Maintenance time

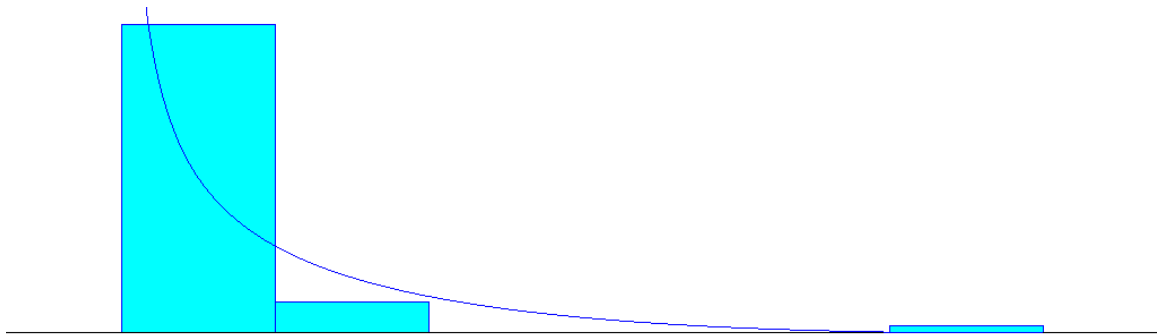

### Distribution Summary

Distribution: Beta

Expression:  $18 * \text{BETA}(0.471, 3.22)$

Square Error: 0.012626

### Chi Square Test

Number of intervals = 2

Degrees of freedom = -1

Test Statistic = 6.04

Corresponding p-value < 0.005

### Kolmogorov-Smirnov Test

Test Statistic = 0.374

Corresponding p-value < 0.01

### Data Summary

Number of Data Points = 45

Min Data Value = 0.3

Max Data Value = 18

Sample Mean = 2.29

Sample Std Dev = 2.77

### Histogram Summary

Histogram Range = 0 to 18

Number of Intervals = 6

## 7. Accessory Maintenance time

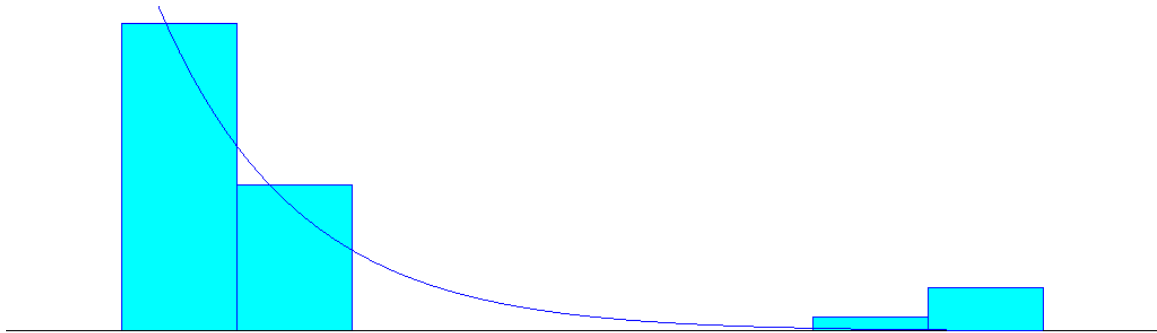

### Distribution Summary

Distribution: Exponential  
Expression:  $0.999 + \text{EXPO}(0.907)$   
Square Error: 0.024912

### Chi Square Test

Number of intervals = 3  
Degrees of freedom = 1  
Test Statistic = 10.3  
Corresponding p-value < 0.005

### Kolmogorov-Smirnov Test

Test Statistic = 0.133  
Corresponding p-value > 0.15

### Data Summary

Number of Data Points = 70  
Min Data Value = 1  
Max Data Value = 6.5  
Sample Mean = 1.91  
Sample Std Dev = 1.67

### Histogram Summary

Histogram Range = 0.999 to 7  
Number of Intervals = 8

## 8. Electric Maintenance Time

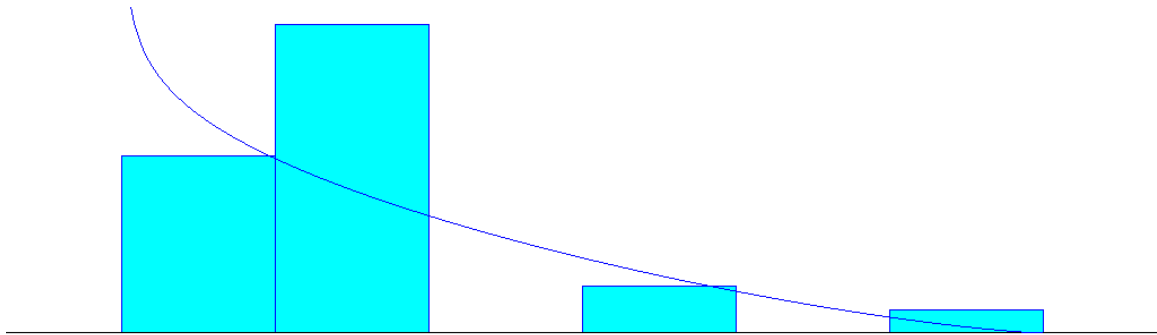

### Distribution Summary

Distribution: Beta

Expression:  $0.999 + 19 * \text{BETA}(0.861, 2.35)$

Square Error: 0.130613

### Chi Square Test

Number of intervals = 4

Degrees of freedom = 1

Test Statistic = 26.9

Corresponding p-value < 0.005

### Kolmogorov-Smirnov Test

Test Statistic = 0.214

Corresponding p-value = 0.0232

### Data Summary

Number of Data Points = 47

Min Data Value = 1

Max Data Value = 20

Sample Mean = 6.1

Sample Std Dev = 4.1

### Histogram Summary

Histogram Range = 0.999 to 20

Number of Intervals = 6

