

**Addis Ababa University**  
**School of Graduate Studies**  
**Department of Psychology**

**Validation of Self-concept Measurement in Amhara Culture: A  
Case of Children from Three Rural Schools**

**By**

**Melaku Zeleke**

**Advisor: Dr. Teka Zewdie**

**June 2014**

**Addis Ababa University**  
**School of Graduate Studies**

**Validation of Self-concept Measurement in Amhara Culture: A  
Case of Children from Three Rural Schools**

**A Thesis Submitted to the School of Graduate Studies of Addis Ababa University  
In Partial Fulfillment of the Requirements for the Degree of Master of Arts in  
Developmental Psychology**

**By**

**Melaku Zeleke**

**Advisor: Dr. Teka Zewdie**

**June 2014**

## **Acknowledgments**

I would like to extend my gratitude to individuals who have helped me in accomplishing this thesis. Firstly, I would like to thank my advisor Dr. Teka for his encouragement and support of me to do what is necessary for the realization of the study. While I was in the field to collect data I was significantly indebted to Ato Teshome (Basonawerana Woreda Education Office) and school directors – Ato Ketema (director of Angolela School), Ato Yimer (director of Woinabadera School) and Ato Admasu (director of Daletinamekegne School).

# Table of Contents

<b>Title</b>	<b>Page</b>
Acknowledgments.....	i
Table of contents .....	ii
List of tables and figure.....	iv
List of appendices.....	iv
Abstract.....	v
 <b>Chapter I – Introduction</b>	
1.1 Background.....	1
1.2 Statement of the problem.....	2
1.3 Research questions.....	4
1.4 General objective.....	5
1.5 Specific objectives.....	5
1.6 Significance of the study.....	6
1.7 Limitations.....	6
 <b>Chapter II - Review of the Literature</b>	
2.1 Historical Background.....	7
2.2 What is self concept?.....	8
2.3 Global versus domain specific self-concept.....	10
2.4 Conceptual differences.....	11
2.5 Importance of self-concept.....	13
2.6 Theoretical approaches and theoretical models.....	14

The Shavelson, et al model of self-concept.....	18
2.7 Stages of self-concept development.....	20
2.8 Cultural generality and specificity.....	25

**Chapter III - Method**

3.1 Sample.....	29
3.2 Instrument.....	30
3.3 Procedure.....	33
3.4 Focus group discussions.....	35
3.5 Data Analysis.....	35
Validity, reliability statistical analysis.....	35
Confirmatory factor analysis.....	36

**Chapter IV - Results and Analysis**

4.1 Preliminary analysis.....	38
Internal Consistency Estimates.....	38
4.2 Factor Structure for the SDQI Responses.....	39
4.2.1 Goodness of fit.....	39
4.2.2 Parameter estimates.....	44
4.2.3 The Harter Model.....	48
4.2.4 The assessment of the 8 factor model.....	51
4.2.5 Sex and Age Effects.....	54
4.3 Responses in the focus group discussions.....	56
4.4 Discussion.....	59

## **Chapter V...Summary and Conclusions**

5.1 Summary.....	68
5.2 Conclusions.....	70
Recommendations.....	71
References.....	72

### **Tables and figure**

Table 1: Respondents by Gender and Age.....	page 38
Table 2: Coefficient Alpha Estimates of Reliability for Each Age Level and the Total Sample.....	39
Table 3: Goodness of Fit Indices for Alternative Models for Children Ages of ‘8 to 9’, ‘10 to 11’, ‘12 years’, and for the Total Sample (TOT).....	43
Table 4: Summary of Parameter Estimates for Confirmatory Factor Analyses of the Three Age Groups and the Total Group for the 8-factor A Priori Model.....	46
Table 5: Goodness of Fit Indices for Alternative Models for Children in Ages of ‘8 to 9’, ‘10 to 11’, ‘12 years’, and the Total Sample (TOT) Based on the Harter and Pike (1984) Model.....	50
Table 6: Indicator Reliability and Validity Measures for the 8 Factor Model.....	52
Table 7: Fornell-Larcker Criterion Analysis for Checking Discriminant Validity.....	54
Table 8: Sex and Age Effects in the SDQI Scale.....	55
Figure 1: Structure of self-concept (Shavelson and Bolus, 1981).....	16

### **List of appendices**

Appendix 1 Questionnaire.....	page 77
Appendix 2 Focus group discussion questions.....	82
Appendix 3 List of participants in the study.....	83

## Abstract

*The problem of this study is that there is lack of valid and reliable self-concept instruments that measure the hierarchical and multidimensional facets of self-concept. While there are many such kind of validated instruments in other parts of the world, particularly in the West, no significant validation of instruments is carried out in Ethiopia, and particularly in the Amhara cultural community. The validation of the Self Description Questionnaire I (SDQI) by this study helps to conduct further studies by the instrument so that more self-concept theories will be supported and interventions will be designed based on findings than what was done before. The purpose of the study is to find out the validity and reliability of the Self Description Questionnaire I and the applicability of its related theories among the Amhara community.*

*In the study 132 students whose age is from 8 to 12 were selected from Amhara community in North Showa using convenient sampling. A questionnaire was administered on the children and focus groups discussions were held. The children completed the 76-item SDQI that measures the 8 facets self-concept. The analyses were done using the AMOS approach to Confirmatory Factor Analysis. Sex and Age effects in the multiple dimensions of self-concept were tested using multivariate and univariate Analysis of Variance.*

*Validity, reliability and factor structure of the SDQI scales is established by the responses that supports the use of the SDQI on children of the Amhara community; the reliability median estimates have shown some increment with age. Individual indicator reliability is established while there are high levels of internal consistency reliability in all eight factors. While convergent validity among the factors is partly confirmed discriminant validity was not well established.*

*The hierarchical and multidimensional structure of self-concept of children is dominantly demonstrated as stipulated by the one general factor, two factor, and 8 factor models and the qualitative data. The 8-factor model has the highest fits to the data both for total group and for each age group and its parameter estimates show that all 8 factors are distinctly demonstrated. Some data imply that the children rate themselves less in older ages than they used to do in their earlier ages. It is inconclusive, however, as to whether children better differentiate the eight self-concept dimensions as their age increases. The highest correlations involve the math and school scales while general self is affected most by math and school selves. With regard to the total group it is ability and peer relation that have the highest correlation. The sizes of the uniquenesses decrease with age. When total self-concept that is averaged across all 8 scales is assessed the effects of age was significant, while the effect of sex and their interaction were non-significant.*

*Since the validity, reliability and factor structure of the Self Description Questionnaire I scales is established by the study it can be an inducement to do further similar studies in this regard in the future or the instrument can be used to study most of the 8 facets of self-concept in future studies than focusing on a single or two dimensions of self-concept. Since care and socialization practices in the culture may be grounds for most of the differences in differentiating the facets of self-concept by the children the situation has to be studied further. As general self-concept seems to be affected most by school related factors, the reasons for this need to be further studied. Since the decline or increase of level of self-concept rating with age is not conclusively supported in the targeted age groups future studies may clarify the precedence behind this finding.*

# **Chapter I – Introduction**

## **1.1 Background**

As elsewhere in the world, the welfare and development of Ethiopian children is at stake. As compared to physical development, though it plays a critical role to the overall development of children, psychosocial development has been getting a minor focus in child development studies in Ethiopia. One of the psychosocial aspects that affect children's development is self-concept that refers to the understanding of a person about himself or herself.

In this study it is assumed that positive self-concept is universally valued by cultures, though its manifestations may vary depending on the situation of the given culture, as a potential mediating influence leading to other desired effects. Among these effects are various competencies including children's adaptability in social situations, empathy and academic prowess. Watkins (2000) explains that it affects development depending on the culture and context in which it exists. To find out what problems are occurring to self-concept development of children, besides general self-concept, it is needed to know about its contents with regard to what specific dimensions of self-concept exist and how they develop thereby interventions would be carried out according to respective problems and cultures.

The status of the multidimensionality and the factorial structure (or dimensionality) of self-concept for children in different cultures is not sufficiently studied. It is important to test multidimensional and hierarchical character of self-concept and its developmental nature in the Ethiopian context as well as the cross cultural validity and reliability of instruments. This study is a research on the applicability of the western self-concept models on children of Amhara cultural community in Ethiopia. Confirmatory factor analysis, multitrait and cross sectional analyses will be used to provide support for the generality of the multidimensional model of self-concept and the validity and reliability of the Self Description Questionnaire I (Marsh, n.d) measure across non-western cultures, especially in the Amhara community in children of three rural schools in North Showa Zone.

Thus, in this thesis instruments and the major theoretical models related to self-concept, which have been mainly developed and supported by studies in the western cultures, are analyzed as to whether they can work in the Ethiopian culture. The cross-cultural applicability and generality of the self-concept measurement and its related theoretical models will be investigated. Analyses on the cross sectional data that are collected to find out the generalizability of the major theoretical models that are developed in individualist cultures is made on Amhara children who are from a collectivistic culture.

## **1.2 Statement of the problem**

Self-concept has psychological, behavioral, motivational, educational and social effects on children's development. Despite the critical importance of self-concept with regard to children's development, there has been a negligible study conducted in Ethiopia as to the facets and development of self-concept and their respective problems that requires appropriate understanding and provision of nurturing based on values and needs of a community. Despite the fact that there may be common ends to self-concept development which parents and communities everywhere aspire their children achieve, self-concept development of children that is contextually taken to be normal in different communities needs to be known.

Even if there are several researches done on children with regard to validating self-concept instruments and related theoretical models in other parts of the world, there is scarcity of such studies in Ethiopia and Amhara culture in particular. Sufficiently validated instruments that measure self-concepts in our culture need to be devised. In this regard, one of the most validated (Marsh et al, 1990) instrument for conducting study on self-concept development in other cultures, the Self Description Questionnaire I is an ideal one to test its reliability and validity in our context. Theory and research in self-concept development will be boosted when the validity and reliability of multidimensional instruments like the SDQI is supported in various cultural communities in Ethiopia.

Even if there have been theories of self-concept development developed in other parts of the world, they are not sufficiently studied as to their generalizability in cultures in Ethiopia. According to the theories, self-concept needs to be measured as both a structure and a process. As a process it is both dependent on cognitive development and reaction of situational stimuli. Understanding its dimensions is not sufficient that we need to know about how it develops. Among these theories is the Shavelson, et

al model of self-concept of 1976 (cited in Marsh et al, 1990) that proposes a multifaceted, hierarchical construct that increasingly develop with age into distinct facets. According to researches elsewhere in the world there are more than eight types of self-concepts and three hierarchies identified (Byrne et al cited in Marsh, 1990).

There is a need to evaluate the factorial structure of self-concept responses for Ethiopian children in general and Amhara children in particular that helps to determine whether the multifaceted factors like those identified in the responses of children in other cultures can be found. The availability of this data with regard to the type of self-concepts that children have would help to conduct further study as to their respective problems and solutions. Children need to get care and socialization based on the respective needs of the types of self-concepts they develop based on the value of the respective community.

Even though there are studies conducted in Ethiopia regarding problems in self-concept development, there are no sufficient studies conducted in pattern of self-concept development in Ethiopia in general and in Amhara community in particular. As stipulated by studies in the west, the dimensions of self concept diversify and self concept decline as children increase in age and their competences increase (Marsh et al, 2000). This needs to be studied in the Ethiopian context. Finding out the types of self concepts that develop at particular ages of children and pattern of development helps to conduct studies in the future about their problems of development and provide the appropriate nurturing.

Researches in other cultures have shown that global self worth is noticeably strengthened in children of age 8 (Harter and Pike cited in Marsh et al., 1990). Global sense of self-worth starts to be shown and specific facets of self-concept begin to be well differentiated after this time (Harter and Pike cited in Marsh et al., 1990). Academic self concept, for instance, gets differentiated from other facets of self concept beginning from elementary school years (Stipek and Maclver cited in Marsh et al., 1990).

Most of the available studies on self-concept in other parts of the world as well as Ethiopia continue to depend on one measure of one facet of the construct, typically global self-esteem, measured at once, producing *an unduly constricted view of self-process and the way behavior is shaped in situations* (Demo, 1992; Ephrem, 1999; Solomon, 1999; Nuredin, 2006).

What is of importance is also the interrelationship among the dimensions of self concept. It is important to know what factors or dimensions are culturally related and important as to dominantly

influencing the level of general self worth. This helps to discover what aspects of self-concept are most valued and nurtured in the culture thereby to design further studies and make appropriate interventions to problems of communities.

According to researches, there are differences with regard to gender and age as to the factor structure of self-concept and developmental patterns which also needs to be studied in the Ethiopian context.

Studies to find out problems occurring to self concept development in a given community can be carried out only when a theoretically explainable culturally normal way of such development is identified through an instrument that is valid and reliable in the culture. The instrument helps to find cultural data that may support or modify the theories of self-concept development. If the Self Description Questionnaire I is found to be valid and reliable then it is appropriate to consider its results meaningful indicator of self concept development in the culture. The dominant pattern of self concept development of children in a community is their normal way of development. If a specific dimension of self concept is a major determinant of general self worth in a culture, then positive self concept with regard to this dimension is more valued than others.

This is because children measure themselves partly based on the expectation they think their parents or community have about them. There are ways the cultural tradition and social practice of the community in focus regulate, and transform the psyche of the children in the community. A given developmental pattern of self-concept in a community is accepted and valued by a community because communities value or accept the result of their cultural ideas and practices that are also adaptable to the environment.

In order to make children's self concept develop in the desirable way based on the values of a society, its state in Ethiopia has to be studied based on responses of the subjects. Further studies will be able to study the antecedents for the given state of self-concept development. Thus, validating instruments and studying the structure and pattern of self-concept development in various cultural communities in Ethiopia in general and Amhara community in particular is essential.

### **1.3 Research questions**

1. Are the Self Description Questionnaire I scales and the factors reliable and valid and have a consistent factor structure and pattern of factor loadings in the Amhara culture?

2. Do the responses of the children demonstrate an increasing number of facets as age increases in the Amhara culture?
3. What are the factor interrelation/correlations in the Amhara culture in comparison to those found in the Western culture?
4. Do level of children's self concepts decline in middle childhood as they increase in age in the Amhara culture?
5. Are there statistically significant gender and age differences in self-concept?

## **1.4 General objective**

The main goal of the research is to culturally test the generalizability of the factor structure, differentiation of self-concept as children's age increases, stability of self-concept of children over time, interrelationship of self-concept facets, age and gender differences in self concept, and investigating the validity of the Self Description Questionnaire I in the Amhara culture.

## **1.5 Specific objectives**

1. To discover whether the Self Description Questionnaire I scales and the 8 factors are valid and reliable in the responses of the respondents,
2. To find out the multidimensionality of self-concept (whether the self description questionnaire I scales have a consistent factor structure and pattern of factor loadings and to determine whether the factor structure of the questionnaire found with children of another culture can be replicated) in Amhara culture,
3. To test the theory that self-concept is hierarchical and has increasing number of dimensions with age and provide more specific data on how the factor structure of self-concept varies in the age range of 8 to 12,
4. To find out the correlation among the factors of self-concept among the respondents,
5. To test the theory that self-concept decline in middle childhood,
6. To evaluate sex and age effect in self-concept among the respondent children of the Amhara community.

## **1.6 Significance of the study**

The study focuses on self-concept that is an important dimension of development contributing to the psychosocial development of children. Investigating the validity and reliability of the Self Description Questionnaire I is important to understand its significance to be used to measure the self-concept of children in Ethiopia in general and in Amhara culture in particular. If the questionnaire is found valid and reliable researchers use it in the future to study the factor structure and level of self-concept and interrelationship among the dimensions of self-concept in the culture as well as their development.

The study helps to understand the pattern of development of the various dimensions of self concept as children's age increases that helps both researchers and practitioners. The research is important for researchers to conduct more research to study further problems in self-concept development based on the theory of development of multidimensionality and hierarchical nature of self concept in the culture as well as the extendability of the theory that self-concept declines in middle childhood as children increase in age. This helps to conduct further studies and to enrich the theories of self-concept. Practitioners, like teachers and counselors, can also use the researches based on the theories to design their intervention strategies.

Understanding the structure, pattern of development, and the level of self concept helps to conduct future studies as to antecedents and consequences of such development and to take appropriate interventions based on the needs and values of the culture in focus.

## **1.7 Limitations**

During the travel to the field for the data collection there was high number of absent students in all the three rural schools that the study focused. That was beyond the expectation of the researcher and there was time shortage on the part of the researcher to come back and go there again another time. The number of questionnaires filled was less than originally planned because of this limitation. Even though the total sample size is sufficient for confirmatory factor analysis, it would have been better if the study had taken more samples of students for individual age groups.

## Chapter II

### Review of the Literature

#### 2.1 Historical Background

Study on the self concept has seen ups and downs in its history. In the first half of the 20<sup>th</sup> century radical behaviorists had preference to do a rigorously empirical and experimental study of behavior than theoretical constructs like self-concept. This is because, though they do not deny the existence of mental processes, they believed that these kinds of constructs are loosely related to observable events and objects that developing theories to explain them is less important (Dumont, 2010).

The situation has been changing, however, because of the following changes in the past fifty years. First, researchers aspired to distance themselves from the behaviorist tradition, from the psychoanalytic way as well as the way of the natural sciences (Dumont, 2010). In this regard Humanist psychologists ... *felt that both psychoanalysis and behaviorism were too pessimistic, either focusing on the most tragic of emotions or failing to take into account the role of personal choice* ... (Cherry, n.d). Secondly, cognitive psychology began to develop as a field in the 1940s and 1950s. Fields of study like information science and cybernetics developed thereby creating opportunities for thinkers to get new ways of thinking to create new cognition theories. This helped to conceptualize the structures of the mind. Thirdly, new developments in the neurosciences helped to get knowledge as to *the neural maps that we make of our internal body states and the state that we refer to as consciousness – and eventually as self* (p. 186). Among the neuropsychologists, Damasio (cited in Dumont, 2010), gave a neural clarification for a psychology of self.

Preyer and James are among the pioneers of self-concept study. Preyer (cited in Oppenheimer, 1990) in 1882 wrote that children begin to have the ‘the I feeling’ before they learn words. Language helps to specify the comprehensible distinctions of the "I".

Baumeister (1987) explained that historically the problem of the self has evolved in four aspects, which are *knowing and conceptualizing the self; defining or creating the self; understanding one's potential and fulfilling it; and relating the single self to society* (p.163).

Hau et al (2000) clarified that before the 1980's self-concept was considered as a unidimensional, general, and global construct. After that its multidimensional and content specific nature began to be taken into account.

## **2.2 What is self concept?**

Self-concept is one of the dimensions of psychosocial development of children. Shavelson, Hubner and Stanton (cited in Shavelson and Bolus, 1981) defined it as:

*Self-concept...is a person's perception of him or herself. These perceptions are formed through one's experience with and interpretations of one's environment, and are influenced especially by reinforcements, evaluations of significant others, and one's attributions for one's own behavior* (p.1).

As explained by Dumont (2010) the typical usage of the term self like in "I served myself" is different from what is used in the scientific discourse that is

*...what we intend to convey [by the term] when we say that humans can sense at their core the agency and the ownership of their unique experiences and acts. Their sense of self springs from the conviction that the thought they are mulling over in their minds or the pain or pleasure they are experiencing belongs uniquely to them.* (p.187)

As explicated by Oosterwegel and Oppenheimer (1990) the self-concept is a construct having discrete concepts underneath. These concepts involve the actual self and a variety of "possible selves" (Higgins cited in Oosterwegel and Oppenheimer, 1990); the actual self and the varieties of "possible selves" have different degrees of differences in different individuals based on their cognitive development and individual experience. Markus and Nurius (cited in Oppenheimer, 1990) explain that the ideal and ought-to-be selves make up "possible selves". These imply the way in which individuals believe about their potentials as well as their future. A person's actual self perception is the actual self while the

possible selves play mostly of *a motivational function in that they function as inner guides*. If individuals encounter significant differences between the actual and the possible self there will be different forms of emotional or motivational *problems* (Higgins cited in Oppenheimer, 1990).

With regard to the development of these components of self-concept, Oosterwegel and Oppenheimer (1990), studying children of 6 to 16 years of age, suggested that starting from the age of six, it is experience rather than cognitive abilities that mainly influence the extent of differentiation between the several concepts that underlie the self.

Higgins (cited in Oppenheimer, 1990), explaining about the three kinds of selves that are the actual, ideal, and ought-to-be selves, clarifies that:

*The actual self refers to the self-concept as it is commonly used in the literature--that is, the attributes or characteristics a person ascribes to himself or herself. The ideal self involves the characteristics a person would 'like' to possess. The ought to-be self contains the characteristics a person believes he 'should' possess and reflects a moral consciousness or cultural norms and values. (p.9)*

As self-concepts of a child develop by reciprocal interactions between the child and the environment, the actual and possible selves of a child do not consist only of the child's own ideas about the self; both self-attributions and attributions to the self by others influence self concept (Broughton cited in Oppenheimer, 1990). In describing themselves children describe their own ideas about their self, and their ideas about how others perceive them.

As stated by Annerieke Oosterwegel and Louis Oppenheimer (1990), there are two interrelated dimensions for the self-concept.

*The first dimension involves the relationships among the actual self-concept and the various possible selves. The second dimension concerns the distinction between the personal perspective ... and the "supposed perspectives" of others ... The integration of both dimensions results in four different self-concept categories: (a) the actual self perceived from the person's own perspective, (b) the actual self as perceived by the person from the supposed perspective of*

*others, (c) the possible selves as perceived from the person's own perspective, and (d) the possible selves as perceived by the person from the supposed perspective of others. (p.10)*

As stated by Oppenheimer (1990), these interrelationships among the different forms of self concept are dynamic and marked by differentiation and integration.

## **2.3 Global versus domain specific self-concept**

Self-concept can be thought of in two contrasting ways. One of these perspectives is an all encompassing, global (also "self-esteem" or "general self-concept") feature of the person's self-concept, while the other refers to self-evaluations of different dimensions of behavior. The global viewpoint is the relatively older view. The self-evaluations specific to different domain models focus on self-evaluations of specific abilities like physical self-concept, academic self-concept, and the like (Strein, 1995).

Harter (cited in Marsh et al., 1990) explained about the importance of both the multidimensional and relatively unidimensional global self-concept; both content specific scales and global scales are essential. Self Description Questionnaire I has been instrumental in supporting both models of multidimensionality and hierarchy (as proposed by Shavelson et al) and mixture type (as suggested by Harter) in researches.

As clarified by Marsh (1985) there have been different uses of the term general self-concept. In the hierarchical model of Shavelson the apex is called hierarchical general self-concept. This hierarchical general self-concept is defined by the dimensions of self-concept. On the other hand, scales particularly *designed to measure a relatively unidimensional construct that is superordinate to particular facets of self-concept* (p.4) are also called general-self scale or general self-esteem and refers to a general sense of self-worth that is one of the different facets as used by the SDQ instruments and are able to be recognized from other specific self-concept facets. Even if there are these distinctions between the two general self-concepts they are not a totally demarcated concepts. In this regard Marsh (1985) explains that *while both the hierarchical general self-concept and the general self-esteem are superordinant facets, the theoretical relation between them is unclear and the role of general self-esteem is not specified in the Shavelson model.* (p.4)

Marsh further explained that researches on the hierarchical structure of self-concept began to include a general self-esteem scale in addition to multiple facets of self-concept. For this purpose, *a General-Self scale (a general self-esteem scale) was added to each of the SDQ instruments.* (p.4)

Even if Harter and Pike maintain that below age 8 children do not understand general self-worth items or provide unreliable responses, Coppersmith (cited in Marsh et al, 1990) disagrees with Harter's assumption because, as stated by him, ... *distinctions among specific domains are made by young children 'within the context of the over-all, general appraisal of worthiness that children have already made'.* (p.5)

In a study by Marsh et al. (1990, 2000), to refute the Harter and Pike conclusion that children below the age of 8 do not develop general self concept, found out that, using individually administered interview technique, children from 5 to 8 years old identified general self-concept along with the other dimensions of self-concept.

According to Harter (cited in Marsh et al., 1990), hierarchical organization of self concept starts during the concrete operational period that is middle childhood. This is for instance, *I'm smart because I'm good at reading, spelling, and mathematics.*(p.7) As noted by Harter, children have not the capability to form a general self-concept by combining specific aspects of self before the age of 8; children that *at this stage think they are all good (or all bad) across a wide variety of domains.*(p.7) Marsh et al. (1990), however, contend based on Coppersmith's position that if the facets of self-concept are derivatives from a general sense of self children do not need integrative ability in order to have sense of general self and they state that it is inappropriate to conclude that children in their early childhood do not have a general self-concept.

## **2.4 Conceptual differences**

Self-concept is different from other similar constructs involved in self conception like self awareness, self recognition, self understanding, self image, self worth, and self esteem. Self awareness precedes all aspects of self development. Infants find and construct selves for themselves. As believed by Watson (cited in Santrock, 1998) as early as the first few days of life, infants have the capability to

differentiate themselves from others; they, however, make efforts throughout their first 3 or 4 months to demarcate the self from others.

Self recognition is a form of rudimentary self understanding that develops around 8 months of age in which they recognize their bodies in mirrors (Shamrock, 1998). As infants grow they are not limited to visual self recognition that they begin to use language to communicate their ideas. Self understanding occurs when a person cognitively represent the self. This self is the substance and content of the self concept. Roles and membership categories partly explain a child's self understanding. It plays a role in being rational foundation of personal identity. There are three aspects of self understanding. These are personal memories, representations, and theories of the self. Santrock (1998) explains about their differences as

*... personal memories are autobiographical episodes that are especially important in thoughts about oneself. These might include memories of a fight with one's parents; a day spent with a friend ... Representation of the self includes the generalized ascriptions individuals make about their selves. For example, individuals have representations of their actual selves (such as 'I am big, smart...), their ideal selves ('I want to be a teacher and be respected by the community'), and their past selves ('I used to be very shy'). Theories of the self enable individuals to identify which characteristics of the self are relevant, arrange these characteristics in hierarchical order of importance, and make claims about how these characteristics are related to each other. Theories of the self provide an individual with a sense of identity and a source of orientation to the world. (p.381)*

In self understanding children define and explain characteristics of the self. They also evaluate these attributes through self esteem and self-concept (Santrock, 1998). According to Santrock (1998) self esteem, self worth and self image refer to the same idea while self concept is different. He further explains that self esteem (also known as self-worth or self-image) is the global evaluative aspect of the self. Self-concept refers to evaluations of the self that is specific to the different facets of self concept like physical appearance.

## 2.5 Importance of self-concept

Dominantly in the western culture, high self-concept is a desirable outcome playing a role of boosting other positive psychological variables and academic achievement (Hau et al, 2000). Craven (2000) also explains that a positive self-concept highly contributes to the achievement of several social, physical, emotional, and developmental outcomes. Watkins (2000) mentions that self-concept is instrumental in the development of cognition, emotion, and motivation. According to a University of Western Sydney website (2004) children need to develop their positive self concept because it has benefits in the process of making choice and planning. It boosts their persistence and achievements. It also helps in *improving physical fitness; enhancing the education of disadvantaged and gifted students; decreasing school violence, bullying and victimization; as well as sports psychology to help ... athletes win ...*

Unless self-concept develops in a manner that boosts positive self it may cause temporary or prolonged disturbances in psychological development. Explaining about the importance of positive self esteem (general self) Santrock (1998) mentions that low self esteem in some children may cause depression, suicide, anorexia nervosa, and delinquency.

Cairns and Cairns (cited in Oppenheimer, 1990) state that cognitions about the self functions for:

- (a) *the preservation of 'self integration and direction';*
- (b) *'the facilitation of adjustments to the external world of social and nonsocial Events';*
- (c) *the projection of one's 'actions into the future through the formulation of plans, goals, and dreams', and*
- (d) *'the facilitation of adaptation to the physical world' (p.3)*

Attending to the self-concept of children is important when age and gender dimensions are focused on. As stated by a study focusing on late childhood and adolescence (Greenberg-Lake, 1994), for instance, while self-concept declines for both boys and girls, *adolescent girls are more likely than boys to have their declining sense of themselves inhibit their actions and abilities. This [gender] difference grows more pronounced with age. The study further explains that, the loss is most dramatic and has the most long-lasting effect for girls.*

## 2.6 Theoretical approaches and theoretical models

There are theories that explain about the nature of self-concept. Among the earliest theoreticians is James (cited in Dumont, 2010 and Oppenheimer, 1990) who in late 19th century theorized that what is called self is a "fluctuating material" by which he means that *the same object being sometimes treated as a part of me, at other times as simply mine, and then again as if I had nothing to do with it at all.* (p.1) In the broadest sense, as stated by James, the Self of a person includes all what "he CAN call his". According to him, the self concept is divided in to three parts, which are its "constituents", "the feelings and emotions they arouse" and "the actions to which they prompt". Oppenheimer explains about James's idea of constituents of the *I* to refer to the features of the *I* and the *Me* in which

*...[t]he 'I' involves the self-as-knower -- that is, the self-as-subject, and includes aspects like continuity, distinctness, volition, and self-reflection. The 'Me' involves the self-as-known--that is, the self-as-object. ... a person may know himself ...[in ways], such as the material, the social, and the spiritual me. While the self-as-known can be empirically studied, the self-as-knower 'is a much more difficult subject of inquiry ... it is that which at any given moment is conscious, whereas the Me is only one of the things which it is conscious of'. (p.1)*

As explained by Baldwin what is called self is a continuous thinking of a person. As quoted by Oppenheimer (1990) Baldwin states that it is a person's thinking of himself/herself *as a pole or terminus at one end of an opposition ... and ... the other pole or terminus is the thought he has of the other person, the 'alter'*. (p.2) According to him, the individual and the environment dialectically interact that results in the incorporation of elements that previously belong to others. As explained by Oppenheimer (1990), Baldwin asserts the self to consist of an already accumulated characteristic and a self that actively acquires new features as that:

*The two poles of the dialectic involve on the one hand a child's self which 'is ejected into the alter. This is the solidified mass of personal material which he has worked into a systematic whole ... the... other self... [is] that learns, that imitates, that accommodates to new suggestions from persons in the family and elsewhere'. ... these*

*two so-called 'selves' are merely 'active attitudes, the content thought of being one and the same' .(p.2)*

Social experience forges one's self that it is made up of socially constructed parts. Others help to define the self that the points of views of other individual members of the same social group or the views that are directed at the social group to which one belongs help an individual to experience oneself (Mead cited in Oppenheimer, 1990).

Based on these theoretical approaches the self is a construct that is either perceived as partly as a known (dependent) and partly as knower (independent) of the social environment (James cited in Oppenheimer, 1990). Based on the idea taken from Baldwin (cited in Oppenheimer, 1990), it is taken as,

*...a product of a dialectic between the person and his environment, and in which the self-as-knower and the self-as-known are inseparably parts of one and the same dimension ... or [according to the idea taken from Mead]as a social construct, the product of 'socialization' through appropriating the attitudes of others in the social environment towards oneself ...(p.2)*

There have been several theoretical approaches to the study of self-concept. Theories of self-concept explain about its development and nature. There have been various studies that support the theories conducted in different parts of the world particularly in the West.

The theories that maintain that children's self concept develops from limited dimensions to more diversified and hierarchical self-concepts, from concrete to abstract, from inflated self ratings to more realistic ratings. They also explain about age and sex effects of self-concept and the strengthening of the capability of global self rating from around age 8 will be reviewed as follows.

Shavelson and Bolus (1981) explain about the following main characteristics of self-concept.

- 1. It is organized or structured in that people categorize the vast information they have about themselves and relate these categories to one another.*
- 2. It is multifaceted and the particular facets reflect the category system adopted by a particular individual and/ or shared by a group.*
- 3. It is hierarchical with perceptions of behavior at the base moving to inferences about self in*

subareas (e.g., academic—English, history), academic and nonacademic areas, and then to general self-concept. 4. General self-concept is stable but, as one descends the hierarchy, self-concept becomes increasingly situation specific and as a consequence less stable. 5. Self-concept becomes increasingly multifaceted as the individual develops from infancy to adulthood. 6. It has both a descriptive and an evaluative dimension such that individuals may describe themselves (I am happy) and evaluate themselves (e.g., I do well in school). And (7) it can be differentiated from other constructs ... (p.1)

Figure 1: Structure of self-concept (Shavelson and Bolus, 1981)

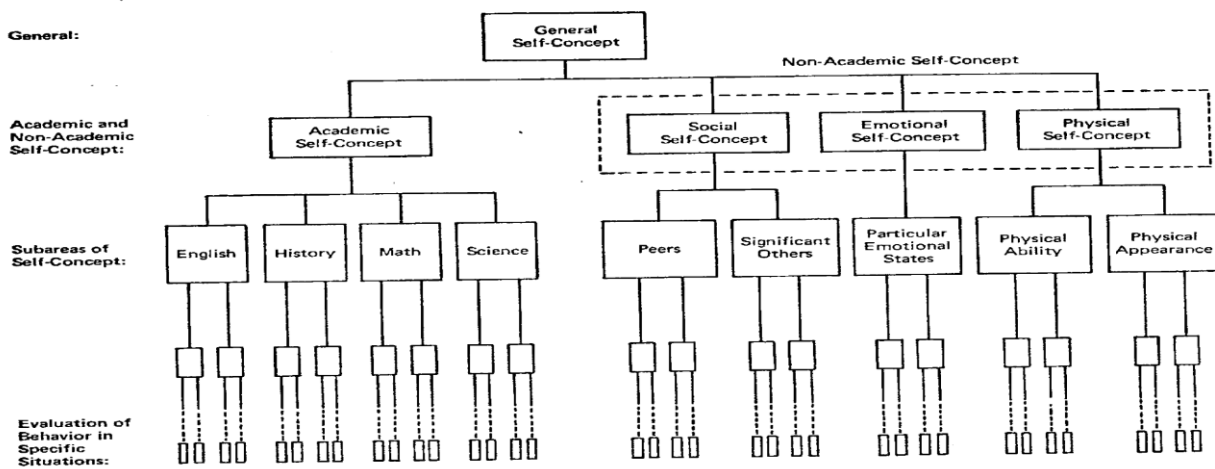

Note: The structure of self-concept shown in figure 1 has gone through some changes like omission of emotional self-concept and subject areas under academic self-concept.

Marsh (cited in Marsh et al, 2000) explains that self concepts of young children are consistently high until they learn their relative strengths and weaknesses through increasing experience. As age increases mean levels of self-concept decreases as well as it gets more differentiated. Marcus and Wurf (cited in Marsh, 2000) explained that *the structure of self depends on both the information available to an individual and the cognitive ability to process this information.* (p.224) As children’s cognitive ability develops they are able to process self-relevant information that

*...self concept becomes increasingly abstract with age, shifting from concrete descriptions to behavior in early childhood, to trait-like psychological constructs (example, popular, smart, good looking) in middle childhood, to more abstract constructs during adolescence (Harter cited in Marsh et al, 2000, p.224)*

Young children become accurate as they increase in age with regard to their responses showing their optimistic bias as they are younger. Thus, there is decline in mean levels of competency self ratings.

As stated by other studies discussed below, while making their self-concept students compare their abilities with other class mates and others who are in their immediate environment. Students with high ability are likely to have more positive self-concept than children in their classes.

As stated by a research by Hau et al (2000), math self-concept and verbal self-concepts are uncorrelated. This is explained using an internal and external frame of reference model. According to the model

*... students compare their verbal ability with that of other students (external comparison) as well as against their own mathematics ability (or other abilities in other school subjects, internal comparison). The former external comparison leads to a positive relation between verbal and mathematics self concepts whereas the latter internal comparison results in a negative one. (p.67)*

In attending schools of high average ability comparison with classmates may have negative effects on students' self-concept. As stated by Marsh (cited in Hau et al, 2000):

*For students of equal ability, those attending high average ability schools will have a lower academic self-concept than the equally able students studying in low ability schools... This is because the former students are comparing their ability unfavorably with other high ability classmates (contrast effect). (pp. 67-68)*

Even if studies show that this situation has a negative effect on students' academic self-concept, there is also a positive side. According to Felson and Reed (cited in Hau et al, 2000), attending schools of high average ability *may have potentially positive impact on self-concept through assimilation or identification*. This results from the fact that these schools *are socially valued and preferentially selected by many parents* for their indication of high academic ability as well as high social status. This identification helps to add to positive self concept. The negative contrast effect work with the positive assimilation effect whose net effect has been demonstrated by studies to be generally negative, *indicating a stronger contrast component to most students*.

According to Gamoran et al (cited in Hau et al, 2000) there are findings that indicate that there is a different explanation as that attending class of high ability students would boost self concept. As asserted by them

*... students assigned to higher-ability tracks learn and perform better than those in the lower-ability tracks. This is because in the higher-ability tracks, more advanced topics are sometimes covered in a faster pace and the teachers are comparatively more enthusiastic. (p.68)*

### **The Shavelson, et al model of self-concept**

The Shavelson, et al model of self-concept of 1976 (cited in Marsh et al, 1990) proposes *a multifaceted, hierarchical construct that become increasingly distinct with age*. Marsh et al. (1990) clarify about the model as that

*...a general facet at the apex of the self-concept hierarchy is divided into academic and nonacademic components of self-concept. The nonacademic is divided into physical, social, and emotional components, whereas the academic component is divided into academic facets in particular subject areas such as English and mathematics. (p.1)*

According to Marsh (1985) the apex of Shavelson's model is hierarchical general self-concept (that is similar to one factor model) and the general self-concept that *measure a relatively unidimensional construct that is superordinate to particular facets of self-concept ... [is] general self-esteem [one of the eight dimensions of self-concept]*. (p.4)

Marsh and Shavelson (cited in Hoy, 2008) are instrumental in formulating the theory of the self as organized in a hierarchical structure. As explained by Hoy (2008) at the top of the hierarchy is a stable sense of self underwhich there are academic and nonacademic elements that branch into more diversified facets.

Chiu (2013) also explains about Shavelson et al. theoretical model of a hierarchical structure of self-concept. According to the theory, it is explained that, self-concept is taken as steady, developmental, and evaluative. By hierarchy it is referred to a system with one single, highest order general self-concept and several lower-order field-specific self-concepts (academic, social, emotional, and physical self-concepts). A lower order field specific self-concept like academic self-concept can be more

differentiated into much lower-order field specific self-concepts for instance, verbal, math, and science self-concepts.

According to Marsh et al (1990), there are three hierarchies identified. Which are the global self-concept at the top, the academic and non-academic self concepts at the middle and the specific facets of self concept at the bottom of the hierarchy. As explained by Marsh et al. (1990) past researches in the West have shown that among children as young as second graders have differentiated this structure.

*... the SDQ factor structure was, reasonably well defined and the internal consistency estimates for the SDQI scales were moderate. In [a study of students in grades of 2 to 5] ... the SDQI factor structure (factor loadings) were reasonably invariant across the different ages ... correlations among the factors became smaller with age. Whereas a similar pattern of hierarchical factors was identified at each age, the self-concept factors became more distinct ...*  
(Marsh et al, 1990, p.2)

The main proposition of the Shavelson model is that self-concept becomes more differentiated with age. The information availability and cognitive development influences a child's structure of the self (Markus and Wurf cited in Marsh et al, 2000). Moreover, children as young as 5 to 8 years were able to differentiate the eight factors of self-concept (Marsh et al, 1990, 2000).

Strein (1995) explains about how, among the theoretical models of self-concept, domain-specific self-concepts are emphasized as:

*...although some theoretical models are hierarchical, with global self-concept at the apex, most of these models stress the distinctiveness of various self-concept facets. ... most published self-concept measures now emphasize domain-specific self-concepts. The clearest example of measures based on the multifaceted view is Marsh's (1992) set of scales [including Self-Description Questionnaire I]*

## 2.7 Stages of self-concept development

Self-concept is formed as a result of the interaction of biological, developmental, and social processes. It is acquired through patterns of interaction with others and is modified as children and adults develop new cognitive and intellectual capabilities and confront new social demands and processes (Demo, 1992). Broderick and Blewitt (2010) state that since the self is a cognitive construction, self-concept is self-knowledge just like any other type of knowledge. Accordingly, knowledge of the self is influenced by the child's general level of cognitive development. There is difference in the particular level of development at which one is functioning in the different domains of knowledge including self-concept (Broderick and Blewitt, 2010). More dimensions of self-concept develop with age and there are underlying changes in the self-system. The development of the child's self-concept goes from undifferentiated situation to a coherent organization as age increases through a progression of stage like changes (Blewitt, 2010). This is similar to the view that there is a general self-concept in earlier years which becomes a source of facets of self-concept to appear afterwards (Coppersmith cited in Marsh et al, 1990).

Infants begin to recognize the consequences of their own behavior, to act intentionally, and to distinguish themselves from others in their environment. Their self-schema is dominated by internal images of one's own physical characteristics (Lewis and Brooks-Gunn cited in Demo, 1992). This precedes self-evaluative emotions and self-regulation (Lewis et al, Stipek et al cited in Demo, 1992). Santrock (1998) explains that it is around their 18 months of life that children recognize their body images in the mirror that is a rudimentary self understanding. They not only recognize themselves that they *coordinate the images they saw with the actions of touching their own bodies*. As stated by theories of the self like psychoanalytic, social learning, symbolic interactionist, early parent-child and child-caretaker relations have essential influence in the development process (Shrauger and Schoeneman cited in Demo, 1992).

Between ages 2 and 4 children begin to think in symbolic terms, to understand object constancy, and to view themselves as objects (Keller et al, Lewis and Brooks-Gunn cited in Demo, 1992). At preschool, children's cognitive development, their ability to hold in mind several ideas at the same time and to integrate these in some meaningful way is, however, quite underdeveloped. Furthermore, preschoolers lack developed perspective taking ability, find accommodating opposing characteristics, or opposing

emotional states difficult (Fischer et al, Harris cited in Broderick and Blewitt, 2010). As a result their self-evaluations may not conform to reality and be overly positive (Broderick and Blewitt, 2010). They lack the role-taking abilities necessary to distinguish their own thoughts and feelings from those of others and they assume that others recognize their inner thoughts and feelings. Sense of self of children in preschool age does not include a stable set of self-feelings or self-attitudes. It is rather limited to their name, aspects of gender identity, age, body image, possessions, personal characteristics, and favorite activities that are changing from situation to situation. Santrock (1998) also explains about the development of self-concept in early childhood that from 2/3 to 5/6 years mostly think of the physical self that is as part of the body, mostly the head. They confound self, mind, and body. They differentiate themselves from others by physical actions, body images, and material characteristics.

An important concept in self-concept development is perspective taking (the capacity to imagine another person's perspective and understand his or her thoughts and feelings) that helps to boost self understanding (Santrock, 1998). Starting from three years of age until adolescence children pass through five stages of development of perspective taking. The first stage is egocentric stage that develops in early childhood and it culminates in the stage in adolescence in which there is in-depth perspective taking (Selman cited in Santrock, 1998). As explained by Selman (cited in Santrock, 1998), the first stage in perspective taking occurs in ages of 3 to 6 and it can be described as:

*child has a sense of differentiation of self and others but fails to distinguish between the social perspective (thoughts and feelings) of other and self. Child can label other's overt feelings but does not see the cause and effect relation of reasons to social actions. [From ages of 6 to 8] a child is aware that other has a social perspective based on other's own reasoning, which may or may not be similar to child's. However, child tends to focus on one perspective rather than coordinating viewpoints. (Santrock, 1998, p. 397)*

At the age of 5 or 6 children realize that gender is constant (Marcus and Overton cited in Demo, 1992). Their egocentric thinking and the limited social environment in which toddlers and preschoolers live prevents the use of social comparisons (Suls and Mullen cited in Demo, 1992). Entwisle et al, Suls and Mullen cited in Demo (1992) explain about self-concept development emphasizing the role of cognitive development.

*By age 5 or 6, as children enter concrete operations, they regularly judge their positive and negative qualities and possess a fairly coherent, hierarchically organized, core or "baseline" self-concept. Increased cognitive sophistication and improved role-taking abilities enable children to consider the perceived judgments and reactions of numerous others in their expanding social environment, and formal interaction with teachers and peers in age-graded educational settings facilitates social comparisons (p.5)*

When children reach the age of elementary-school they start to have organizing capabilities of the features of the "Me-self" articulately into sets of categories. *For example, the child might relate being good at drawing, at coloring, and at cutting as an indication that she is good at art* (Broderick and Blewitt, 2010). There is still often unrealistically positive self perception until the process of development of perspective-taking ability *allow the child to begin to evaluate her own behavior according to others' standards*. In this time children begin to internalize others' rules and that serve as self-regulatory guidelines (Broderick and Blewitt, 2010).

Ruble et al (cited in Demo, 1992) explain that limited cognitive abilities during middle childhood restricts the use of reflected appraisals and social comparisons. This happens at a minimum until age 7 or 8. At this time, however, they have the capability of judging their own actions and comparing performances, abilities, qualities, and physical characteristics happening at different times (Suls & Mullen cited in Demo, 1992). Thus, as stated by Entwisle et al, Gecas and Schwalbe (cited in Demo, 1992),

*... it is likely ... that at this stage self-evaluations and self-attributions of autonomous, efficacious activity, and experiences facilitating the sense of self as an active, causal agent in one's environment, are the most important processes for children's developing self-theories.(p.5)*

As children enter their middle and late childhood their self understanding changes from expressing oneself by external features to internal ones. They also have a tendency to express *themselves in terms of social characteristics and social comparison*. In this stage inner and outer states differentiation is added by recognition of subjective inner states in their definition of the self. Example, *I am pretty good about not worrying most of the time. I used to lose my temper but I am better about that now. I also feel proud when I do well in school*. During this time the social self (like saying I have three close friends) increases. Children change from what I do or not do to about what I can do in comparison with

others. This change in development *provides an increased tendency of establishing one's differences as an individual apart from others*. Beginning from middle and late childhood, in addition to the already developed physical and active self, the internal self, social self, and social comparative self becomes features of self concept (Santrock, 1998).

When children reach the age of 9 to 11 they develop, according to Demo (1992), advanced inductive reasoning and improved classification abilities; this gives them the ability to understand many sources of behavior. In addition to that, Demo explains further that

*... the challenges of schoolwork generate reorganized ways of thinking and refined abilities to compare one's own performances with those of children who are similar on evaluated dimensions. Self-evaluation becomes a salient, lifelong concern during this period...children's thoughts and feelings about themselves are generally positive as they begin elementary school but are more negative, self-critical, and self-doubting in later childhood. (p.5)*

Self-esteem generally decreases from middle to late childhood. As to the main reasons why self concept decline during late childhood the first reason is that *children attach importance to, and judge themselves on, abilities and achievements* (especially academic performances) that are externally observable (Damon and Hart, Rosenberg cited in Demo, 1992). Second, teachers' feed backs and identification with peers increases while parental influence diminishes. This new influences are dominated by actual or perceived, often negative, evaluations of peers and teachers that challenges self-concept, which causes self-doubts (Demo, 1992).

Children, however, begin to have the ability of integrating opposing characteristics and begin to form more abstract trait-like concepts to describe themselves between middle childhood and early adolescence. They grow to be able to integrate opposing self-assessments. General self declines a little during middle childhood and early adolescence as they become aware of their deficiencies relative to the others. Adolescents make efforts to integrate abstract representations of the self (Broderick and Blewitt, 2010)

Early adolescence (12-15) is the beginning of the development of formal operational thought. When explaining the development of this developmental stage Damon and Hart, Rosenberg (cited in Demo, 1992) explain that during this time there is

*... sophisticated deductive reasoning, and more efficient, diversified information processing. The acquisition of these skills enables adolescents to efficiently test hypotheses about themselves at a time when they are extremely introspective and self-conscious, The structure of self-concept during this developmental period is dominated by a psychological interior of inner thoughts, feelings, attitudes, desires, beliefs, fears, and expectations... (p.6)*

Accelerating hormonal production, growth spurts, voice changes, acne that happen during early adolescence bring about changes in the ways early adolescents view themselves in a dramatic and self evident way. The adjustments associated with having several teachers, and making new friends during the transition to junior high school in this age causes challenges (Hirsch and Rankin, Rosenberg, Simmons et al cited in Demo, 1992). More causes that generate disturbances to self concepts are the heightening of parent adolescent conflict and intensification of peer involvement and more involvement in dating. This is a problem at ages of 12 and 13 than at any other time of the life cycle (Simmons et al, Rosenberg cited in Demo, 1992). Adolescents consider about their self-theories as maturation and adjustments to new social roles, changes in physical characteristics, and cognitive abilities increase.

Issues of ego-identity (Erikson cited in Demo, 1992) are resolved in late adolescence in which stability of self is restored, and levels of self-esteem rises. Self-esteem may solidify during adolescence and become less susceptible to evaluations by others. Ellis et al (cited in Demo, 1992) explained

*... that roughly midway through adolescence (10th grade, or about age 16) individuals shifted from evaluating themselves primarily on external standards of achievement to rating themselves primarily on internal standards of personal happiness. (p.8)*

## 2.8 Cultural generality and specificity

The theories mentioned above, however, need to be supported in diverse cultural and geographical contexts. As stated by Rogoff (2003), even if there are regularities, human development does not uniformly take place around the world. A community's goals, cultural institutions and technologies shape development. As stated by her

*... the idea of a single desirable "outcome" of development needs to be discarded as ethnocentric... [the view that] childhood ...[is] a time of preparation for life differs from ways of communities in which children participate in the local mature activities, not segregated from adult life and placed in specialized preparatory settings such as schools ... learning attitude, with suspended judgment of one's own as well as others' ways, is necessary for coming to understand how people both at home and elsewhere function in their local traditions and circumstances and for developing a general understanding of human development, with universal features built on local variations. (Rogoff, 2003, pp.23-24)*

With regard to cultural context Markus and Kitayama (1991) explain that there are divergent aspects of the self that Western and Eastern cultures hold divergent construals of the self, of others, and of the relationship between the two. As stated by the article, as there is an independent view of the self there is also an interdependent view of the self. They state that attending to the self, asserting the self, as well as appreciating one's difference from other individuals is the characteristic of individuals from Western cultures. Eastern cultures, however, nurture the values of conforming to others and harmonious interdependence in their individual members.

Holding a certain view of the self would have cognitive, emotional, and motivational outcomes. Self concept may include others and require others to define it. Markus and Kitayama (1991) explain that *[u]nderstanding the distinction between independent versus interdependent selves provide a means of assimilating separate personality constructs*. As stated by them, the universality and the monocultural approach to the self assumed for many aspects of cognition, emotion, and motivation need to be questioned. Research that have been mainly focusing on Western view of the self need to be geared to sufficiently regard interdependent construal of the self that is dominantly practiced in other cultures.

According to Wästlund (2001), it is not only the concept of individualism and collectivism that explains cultural consturals of the self. There is the concept of optimism that is a feature of cultures that need to be included in the analysis of self-concept in a given culture, particularly non western.

There is a view that the mainstream theoretical models of self-concept and measuring instruments are based on western cultural contexts that critics like Yang (cited in Marsh et al, 2000) say that this makes it related to individualist cultures rather than a collective culture. Markus and Kitayama (1991) also explain that there are independent and interdependent views of the construal of the self that are culturally biased. Triandis (1989) explains similarly about the private and the collective selves.

According to Markus and Kitayama (cited in Hau et al, 2000) an individualistic culture like that of the West views the person as *an independent, self-contained, autonomous entity who comprises a unique configuration of internal attributes...* that is based on personal attributes. This contrasts with the collectivist culture like that of African that emphasizes *the interdependence and harmonious relatedness among one another (e.g., family members, working partners)*. Being harmonious, carrying out one's duty, and involving in different interpersonal relationships is essential in this type of cultures. In these grounds it has been argued that the Western self-concept models do not give sufficient attention to interdependence and other values enshrined in collectivist cultures like that of African.

Another theorist, Baumeister (cited in Hau et al, 2000), on his part explained that cognition plays the role of differentiating cross cultural construal of the self. Hau et al, 2000 explains Baumeister's elucidations as:

*... self-information is organized in a systematic structure and can be classified into three aspects of self, namely, the private, the public, and the collective self. These three aspects of self mean respectively that "the cognitions about traits, states, or behaviors of the person" (e.g., "I am kind"), "the generalized other's view of the self" (e.g., "Most people think I am kind"), and "the view of the self that is found in some collective contexts" (e.g., "My family thinks I am kind"). (p.68)*

As stated by Triandis (1989) the three kinds of self are shown with diverse proportions in different cultures. Individualistic culture is distinguished by that individuals typically exhibit the private self, while individuals from a collectivist culture dominantly show the collective self. He stated that people show more of behaviors that conform to norms, rules, and customs when the collectivist self is activated. At the time the private self is instigated more behaviors based on individuals own attitudes, feelings, beliefs, or personal philosophy will surface.

As to collective self Luhtanen and Crocker (cited in Hau et al, 2000) defined it as *that part of an individual's selfconcept which drives from his knowledge of his membership in a social group(s)*. They stated that collective self-esteem as well as personal self-esteem used to gain positive social identity. They stated that *collective self-esteem could explain aspects of psychological well-being that could not be explained by its relation to personal self-esteem*. Collective self-esteem predicts human behavior (Bettencourt and Dorr cited in Hau et al, 2000). Individuals from a collectivist cultural-heritage have higher collective self-esteem (Buehler cited in Hau et al, 2000).

As concluded by Hau et al (2000), however, these cultural differences are not either sufficient enough to conclude that there are different self-concept structures that differentiates the two types of cultures or their similarities is not so large that a general model is possible. As asserted by Markus and Kitayama (cited in Marsh et, al, 2000 ), the different views of self (that is the independent and the interdependent views of construal of self) may not contradict with each other that they rather complement each other and provide a more complete understanding about the self.

Among the private, social, and collective self that are taken as the major aspects of the self the private self is the most important in current research of the construct. Hau et al (2000) explain this as

*... the cognition about one's traits, states, or behaviors (private self) is the most central and universal characteristic of self-concept. ... For people in the Western and Chinese cultures, the similarities rather than the distinctiveness of their self-concept seem to dominate. In that case, it can be hypothesized that the imported self-concept measure as well as their related theoretical models will still be applicable in the Chinese culture. (p.69)*

As affirmed by Watkins (2000) cultures have differences in the basis of self-conceptions but such differences cannot be solely explained in terms of Western versus Non-Western or a cultural dimension such as Individualism versus Collectivism dichotomy. Moreover, gender differences in self-construal were not consistent across countries. In addition, as stated by Watkins (2000), difference in self-concept as a result of culture and gender difference is yet to be supported by more research.

Even if there is significant body of theory developed with regard to self-concept development with regard to children, Hau et al (2000) assert that quality of self-concept research due to stronger theoretical models, and the development of psychometrically strong, multidimensional measurement instruments based on theoretical models is yet to develop in research with young children. It is also implied that more theoretical formulations and instruments need to be extended and validated through cross cultural research.

# Chapter III

## Method

The methods are tailored in a way they can provide data that help to determine the factorial structure of self-concept and its developmental patterns among the subjects. The study is a cross sectional research in that samples of children from the Amhara cultural community in North Showa are grouped into three different age groups that consist of early and middle childhood (8 to 9 years of age), late childhood (10 and 11 years of age), early adolescence (12 years of age) that is studied at a time to understand changes brought about by age so that differentiation of multidimensional self-concept with age, self-concept constancy over time and age and gender differences in self concept in each of the three groups is found out and compared.

### 3.1 Sample

A hundred and thirty two school attending Amhara children are studied to validate the SDQ I and theories of self-concept development. The children that were subjects of the study were drawn from three rural schools in North Showa (Angolela, Daletinamekegne, and Woinabadera elementary schools) by convenient sampling. They are attending school among whom 70 are male and 62 are female students (their list is attached in Appendix 3). The subjects who are comprised of age 8 to 9 (who are predominantly grade 2 and 3), n=46; age 10 to 11 (who are predominantly grade 3 to 4), n=45; and, age 12 (who are predominantly grade 4 to 6), n=41 participated in the study. They responded to the group administered Amharic version of the SDQI. Cross sectional comparisons are made along these groups. There were also 12 parents that participated in two focus group discussions. The participants in the focus groups were selected based on their knowledge of the community as well as gender and age representation. One group consisted of elderly and young women who have experience of raising children and knowledgeable of the culture. Participants of the other group were elderly and young men who have experience of raising children.

The age groups are formulated based on the literature reviewed above. The first age classification is made to be a group of 8 to 9 years of age children. Even if children as young as 8 have the capability of judging their own actions and comparing performances, abilities, qualities, and physical characteristics

happening at different times, they lack capabilities of reflected appraisals and social comparisons. The age group 10 to 11 years is made as a group because at this time children develop advanced inductive reasoning and improved classification abilities that gives them the ability to understand many sources of behavior as a result of challenges of schoolwork. Feelings about themselves begin to be more negative, self-critical, and self-doubting as they judge themselves on abilities and achievements that are externally observable. Actual or perceived, often negative, evaluations of peers and teachers that challenges self-concept increases. They begin to have the ability of integrating opposing characteristics and begin to form more abstract trait-like concepts to describe themselves.

The third group that is comprised of 12 year olds is formed because it is the beginning of the development of formal operational thought and unprecedented physical changes. These children acquire advanced deductive reasoning, and more cognitive capacity that help to test hypotheses about themselves along with new patterns of social relationships.

### **3.2 Instrument**

The English version of Self Description Questionnaire I (here after SDQI) for preadolescents was translated into Amharic and was administered to the subjects. The instrument is adapted from Marsh (n.d). It is intended to measure self-concept of children whose age is 8 to 12. The instrument is used to find out whether there is consistency of multidimensional and hierarchical factorial structure of self-concept and generalizability of self-concept development theories among the respondents.

As explained by Wylie (1989), the SDQ (that was later referred to as SDQI by Herbert Marsh) was prepared to test Shavelson, Hubner, and Stanton's view that was developed in 1976. The view states that self-concept is organized in multi-faceted and hierarchical manner in which perceptions go from inferences about self in subareas to broader areas and eventually to general self-concept (Marsh, Smith, and Barnes, cited in Wylie, 1989).

Marsh (cited in Wylie, 1989) lists out the original seven self-concept variables that are used in the SDQ and explains about the exclusion of the emotional self-concept scale. He states that there are four aspects of the nonacademic self-concept that include physical ability, physical appearance, peer relations, parent relations while and reading, mathematics, and general are facets of academic self-concept that are included in the scales. One scale that is an emotional self-concept, even if it was

included initially by Shavelson, it was excluded later because young children were found to have difficulty with the items in the scale.

According to Marsh (1985), in order to conduct research on *the hierarchical structure of self-concept that included general self-esteem scale as well as multiple facets of self-concept ... a general self-esteem scale was added* to the SDQI, in addition to the other seven scales already included.

The SDQI instrument is selected also because other instruments focus on global measures of self-concept. According Strein (1995), "Rosenberg Self-Esteem Scale", "The Piers-Harris Children's Self-Concept Scale" and the "Tennessee Self Concept Scale" are instruments *rooted in the global tradition, although each also provides domain-specific scales*.

The SDQI is one of a set of three instruments designed to measure multiple dimensions of self-concept (and gave the strongest support for the multidimensionality of self-concept) for preadolescents (SDQI), for early and middle adolescents (SDQII), and for late adolescents and young adults (SDQIII). The instruments are based on the Shavelson et al 1976 model of self-concept and the facets of self given in that model. Several studies conducted on each of the instruments have identified the factors that each instrument is designed to measure (Marsh, 1985; Marsh et al., 1990, 2000). According to these studies, children's responses have reliabilities and validities (children as young as 5 and above) and there is significant correlation with external features.

In comparison to other self-concept measuring instruments the Self Description Questionnaires are preferred by some. Byrne (cited in Marsh et al, 1990) for instance stated that the questionnaires, namely the SDQ I, II and III are adequately validated. The instruments are related to the hierarchical model of self-concept. Marsh (cited in Marsh et al, 1990) explains about the three areas of self-concept in the SDQI instrument as

*... three areas of academic self-concept (reading, mathematics, and school self-concept), four areas of non-academic self-concept (physical ability, physical appearance, peer, and parent relations) and a general-self scale. Three total scores can also be measured on the basis of these scales; academic self-concept (the average of reading, mathematics, and school self-concept scales), non-academic self-concept (the average of physical, appearance, peer, and*

*parent relations self-concept scales), and total self (the average of academic and non-academic total scales). (p.9)*

The instrument is a self-reporting inventory for ascertaining children's rating of themselves in various specific domains of their life, as well as their sense of global self-worth. It is useful to fully measure self-concept in both global and specific facets of self concept. SDQI is selected because no more fully developed self-concept multifaceted measures were available for preadolescent children (Marsh et al, 1990). Boyle, Byrne, Hattie, Wylie (cited in Craven, 2000) explicate the acceptance of the SDQ especially for school aged students. They explain that the Australian Self Description Questionnaire instruments are widely taken as as the strongest self-concept measurement instrument that focus on multidimensional facets. The fact that it is translated into many different languages around the world is evidence for this.

Studies have examined the psychometric properties of this instrument in the Western setting, but little has been investigated as to the validity of the SDQI in Ethiopian culture. The aims of this study are to investigate validity and internal consistency reliability of the instrument thereby to provide answer to whether the subject children are able to differentiate among specific facets of self-concept in a manner that its distinctiveness increases with age, and to describe age and gender differences.

The SDQI I that is used in this study is based on the Eight Self-Concept Scales that has 76 items. In the investigation children completed the eight self-concept scales; physical abilities, physical appearance, verbal ability, math ability, peer relation, parental relation, general school, and general self-concept scales that denote the following meanings.

**a/ Physical Abilities** - Student ratings of their skills and interest in sports, games and physical activities.

**b/ Physical Appearance** - Student ratings of their physical attractiveness, how their appearance compares with others, and how others think they look.

**c/ Reading** - Student ratings of their skills, ability, enjoyment and interest in reading.

**d/ Mathematics** - Student ratings of their skills, ability, enjoyment and interest in mathematics.

**e/Peer Relations** - Student ratings of their popularity with peers, how easily they make friends, and whether others want them as a friend.

**f/ Parent Relations** - Student ratings of how well they get along with their parents, whether they like their parents, and the quality of their interactions with their parents.

**g/ General-Self** - Student ratings of themselves as effective, capable individuals, who are proud and satisfied with the way they are.

**h/ General-School** - Student ratings of their skills, ability, enjoyment and interest in school subjects in general.

Subjects were requested to judge and to indicate each response to each item on a five point Likert scale, with response alternatives ranging from 5 to 1 based on the degree of evaluation the subjects do to themselves. The English master copy of the questionnaire is translated into Amharic by the researcher (both are attached in Appendix 1).

### **3.3 Procedure**

The SDQI instrument was translated into Amharic and, to effectively measure self-concept of the subject children, it was administered by the researcher. To make accurate measurement of self-concept of the children the researcher assembled students in class rooms and explained the purpose of the research and each child was given a copy of the SDQI. All directors of the three schools and some teachers helped the researcher in the process of administering the questionnaire and maintaining discipline until the tests are completed. The researcher read the instructions aloud, clarified them, and gave examples before they start filling the questionnaires by themselves. The subjects were assured of the confidentiality of their responses. They were assured of the confidentiality of their responses. They were prompted to ask questions and answers were given to questions before they start. All respondents filled the standard five-point response scale (false, mostly false, sometimes true/sometimes false, mostly true, true). Each item was scored from 1 to 5, where a score of 1 represented a low perceived competence rating and a score of 5 indicated a high perceived competence rating.

The examples given at the beginning of the standard questionnaire were written separately on large pieces of paper in large font size thereby they were used in every classroom where students fill the questionnaire to give them examples and explanations about how to respond before every session of administration of the questionnaire begins.

Especially efforts were made to overcome the children's tendency to give socially desirable responses by giving them explanations as to the purposes of the research. All children filled the questionnaires while being attended by the researcher in the class rooms being explained and supported as to how to respond for each question. Negatively worded items were given special clarification. Children were periodically asked if they understood subsequent items during the administration.

Children of 8 and 9 years of age were gathered in separate rooms from older children. They were given more support and clarifications as they respond to items in the questionnaire. All respondents were given chances to ask questions as to unclear questions and to ask repeatedly. Each of the children were followed and supported to help them understand and correctly fill the questionnaires.

Children were encouraged to indicate any difficulties they experienced in responding to an item. They were told to first decide "yes" or "no" to the sentences they read in the questionnaire. It was explained to them that that if they initially responded "yes" then they should think of if they meant "yes always" or "yes sometimes". They were told that if they initially responded "no" they should ask themselves and decide if they meant "no always" or "no sometimes" and then afterwards to encircle the number of their choice.

In the SDQI each of the 8 SDQI scales was defined by responses to the positively and negatively worded items. In the 76 items contained in the standard SDQI there are 12 negatively worded items. For these negatively worded items are shown to be problematic for children to respond special care was given at the time of the administration of the questionnaire by sufficiently reading loud the questions to the students and helping individual subjects while responding the questionnaire.

During collection, the questionnaires were checked for any missing information and for double scoring. In spite of preplanned efforts to avoid misunderstanding, there were some students who have not sufficiently understood some items and did not rightly answer the questionnaires which were discarded.

### **3.4 Focus group discussions**

There are 2 focus group discussions held with knowledgeable elderly people and parents of the community to collect data as to what assessments they have about their children as to whether they differentiate the different dimensions of self-concept and how they rate themselves in different ages. They also provided data with regard to the values, causes and processes that may have caused the given self-concept status of their children that help to collect data as to what are the antecedents and processes working behind self-concept development in the Amhara context. It is important to qualitatively investigate the norm of self concept development in the specific community which is important to know in what dimension and extent of self concept and at what age children are expected to grow in the specified culture (See the questions used in the focus group discussion in Appendix 2).

The result of the focus group discussions will help to find out the external validity of the responses the children will give and the antecedents to their self concept.

Confidentiality was assured for the main subjects of the study and the participants of focus group discussions.

### **3.5 Data Analysis**

#### **Validity, reliability statistical analysis**

Data entry was done on SPSS version 20. The statistical analyses comprise an assessment of the validity, reliability and factor structure of the self-concept responses. Validity or truthfulness of the measurement by SDQI is checked by observing the convergent validity and discriminant validity of the instrument. Reliability or degree of coherence in the way respondents answer to items of the same construct in the scales of the SDQI is ascertained by internal consistency reliability test. For reliability test Cronbach's alpha and other reliability statistics are used.

Factor analyses were done for the total group as well as for responses by each age group independently. The analyses were done using the AMOS approach to Confirmatory Factor Analysis. Sex and Age effects in the ratings of multiple dimensions of self-concept were tested using multivariate and univariate Analysis of Variance.

## Confirmatory factor analysis

The usual way in SDQ research factor analyses is combining item scores into pair. This is because these parcels have tendency *to be more reliable, to be more normally distributed, and to have less idiosyncratic variance than do individual items* (Marsh et al, 2000). Similarly in this study the analyses were conducted based on item-pair scores wherein the first two items in each scale are averaged to form the first item pair, the next two items are used to form the second pair, and the others similarly done. In this manner the 76 SDQI items were condensed to 32 item pairs that were used in the following analyses. Note that after two items are successively combined for each scale those items that are left are added to the last item pair.

In the process of confirmatory factor analysis firstly alternative a priori models to fit the data are hypothesized. Then afterwards the ability of the models to actually fit the data is compared. In this study, the three a priori models that were hypothesized to be true in the responses and are fit to the data from both the total sample and each age group separately are: (a) a one-factor model in which all measured variables loaded onto a single ‘general factor’ factor; (b) a ‘two-factor’ model in which the variables from the three academic scales defined an academic factor and the rest of the measured variables defined a non-academic factor; and (c) an ‘8-factor’ model in which each factor corresponded to one of the SDQI scales. The responses reflect the a priori factor structure because the 8-factor model is defined, which is similar to the design of the SDQI.

The approach to decide whether the fit is sufficient to substantially support an a priori model is *to evaluate the parameter estimates to determine whether they are consistent with predictions and to evaluate goodness of fit for alternative models* (Marsh et al, 1990). The following are among the most useful goodness of fit indicators that are employed in this study.

1. Chi-square goodness of fit statistic ( $X^2$ ) =  $N \times FF$ ; where  $N$  = sample size and  $FF$  is the maximum likelihood fitting function.
2. Tucker-Lewis Index (TLI) =  $TLI = (X_n^2/df_n - X_t^2/df_t) / (X_n^2/df_n - [1.0])$ ; where  $df$  = degrees of freedom and the subscripts  $n$  and  $t$  refer to values obtained from a null model and the target model respectively.

3. Relative Fit Index (RFI) is given by:  $RFI = \rho_1 = 1 - \frac{\hat{C}/d}{\hat{C}_b/d_b}$ . Where  $\hat{C}$  and  $d$  are the discrepancy and the degrees of freedom for the model being evaluated, and  $\hat{C}_b$  and  $d_b$  are the discrepancy and the degrees of freedom for the baseline model.

Lower chi-squares and higher TLIs and RFIs is characteristic feature of better fitting models. A mostly applied guideline of a "good" fit for relative indices like the RFI and the TLI is .90 (e.g., Bentler and Bonett cited in Marsh et al, 1990). In this regard Marsh et al (1990) explain that *in index of .90 can be roughly interpreted as being able to explain 90% of the covariation among the measured variables. The TLI and RFI differ primarily in that the TLI has penalty for model complexity whereas the RFI does not.*

## Chapter IV

### Results and Analysis

In the present investigation children responded to the group administered Amharic version of the SDQI. The factor structure and responses were compared along the three age groups. The subjects belong to Amhara nationality in rural low income families in North Showa and their main livelihood is agriculture supported by animal husbandry. The three schools (Angolela, Daletinamekegne, and Woinabadera elementary schools) in which the subjects attend education are 10 to 12 kilometers away from Debre Birhan Town in Amhara region. The finding and analysis of the study is presented as follows.

Table 1: Respondents by Gender and Age

		Age			Total
		8 to 9 years	10 to 11 years	12 years of age	
Gender	Male	19	22	29	70
	Female	27	23	12	62
Total		46	45	41	132

#### 4.1 Preliminary analysis

##### Internal Consistency Estimates

Internal consistency estimates for the 8 scales (Table 2) are predominantly in the .70s and .80s for each age group except for the total sample in which 5 scales are in the .60s and three scales in .70s. The lowest internal consistency estimate was found for Ability scale for 10-11 year olds (.446). The relatively lower reliabilities are reading (.684) for 10-11 year olds; general self (.590) for 10-11 year olds and general self (.646) for 12 year olds; and other lower reliability is parents scale (.664) for 12 year olds. The reliability estimates were highest for the youngest group (8-9 years) while it decreased for children of 10-11 years of age and increased for children of 12 years of age (median estimates are .781, .705, and .727 for 8-9 years, 10-11 years, and 12 years old students respectively). The data

implies that the youngest group scored highest in the reliability test. Overall, the internal consistency estimates provide reasonable support for the SDQI.

Table 2: Coefficient Alpha Estimates of Reliability for Each Age Level and the Total Sample

	Ages 8 – 9 years	Ages 10 – 11years	Age 12 year	Total Sample
Appearance	.811	.702	.847	.637
Ability	.828	.446	.722	.636
Parents	.712	.796	.664	.673
Peers	.737	.723	.483	.677
School	.742	.707	.732	.734
Read	.790	.684	.799	.678
Math	.772	.749	.883	.730
General	.802	.590	.646	.785

## 4.2 Factor Structure for the SDQI Responses

To support Shavelson’s theory of hierarchical and multi dimensional nature of self-concept in Amhara culture assessment of goodness of fit of three a priori models of self-concept is conducted. Three a priori models of self-concept that are considered in this study hypothesize the following: (a) one general factor; (b) an academic and nonacademic factor, and (c) 8 factors in line with the 8 SDQI scales. The models were mostly fit to the data from each age group independently as well as to the total sample of children in the community. The 8-factor model has best fit of the data and the 2-factor model did better than the 1-factor model. When the 8-factor model is able to fit the data reasonably well it provides evidence for the design of the SDQI. It is right to make parameter estimates based on the 8 factor model because it fits the data significantly better than the 1-factor and 2-factor models.

### 4.2.1 Goodness of fit

All of the three models were fit on the measures to the data for the total sample of children in the community. The values in the analyses show that there is significant fit that the 1-factor, 2-factor and

8-factor models show to the total sample, particularly as indicated by chi-square, TLI and RFI measures.

Assessment of the measures indicates the 8-factor model fits the data substantially better than the 1-factor and 2-factor models; and the 2-factor model fits the data better than the 1-factor model. In measures of chi-square it is 8-factor model (655.67) that is most fit to the total sample data followed by the 2-factor model (815.43), and 1-factor model (1005.12). In measures of TLI it is 8-factor model (.860) that is most fit to the total sample data followed by the 2-factor model (.794), and 1-factor model (.684). In measures of RFI it is also 8-factor model (.672) that is most fit to the total sample data followed by 2-factor model (.621) and 1-factor model (.535). This means when all responses are considered the 8-factors are successfully differentiated by the respondents followed by the 2-factors of self-concepts.

This shows the hierarchical and multidimensional nature of self-concept for the total sample. Even if it is only the 8-factor model that approached 'good fit' (that is .9) all fulfill the requirements of significant fit that is .5 in TLI and RFI. Thus, children that participated in the study are able to differentiate all the three hierarchies and contents of self-concept. One-factor model implies one general self-concept factor; 2-factor model implies academic and nonacademic self-concept factors; and 8-factor model implies appearance, physical ability, peer relation, parental relation, school, math, and reading.

When it comes to the fit of the models to individual groups it is on TLI measure that only 8-factor model is significantly fit to the age groups of 8-9 and 10-11. Individual age groups have not particularly significantly differentiated 1-factor model and 2-factor model while children of 12 years of age have not sufficiently differentiated even the 8-factor model that is the 8 dimensions of self-concept. This contradicts with what is stipulated in the theory that as children increase in age they acquire more ability of defining the 8 factors. What may mitigate this conclusion is that 12 year students have more measures of chi-square than 8 to 9 year olds (though less than 10-11 year olds) which mean they are better able to differentiate the factors than the youngest groups.

Assessment of the measures indicates, similar to the total sample, the 8-factor model fits the data better than the 2-factor model while the 2-factor model fits the data better than the 1-factor model, similarly for each age group. The group of 8 to 9 year old children has defined the 8-factor model (924.23, .515, and .359 on chi-square, TLI, and RFI measures respectively) than the 2-factor model (999.70, .510,

and .356 on chi-square, TLI, and RFI measures respectively) and 1-factor model (1047.34, .470, .328 on chi-square, TLI, and RFI measures respectively). The group of 10 to 11 year old children has defined the 8-factor model (759.68, .517, and .314 on chi-square, TLI, and RFI measures respectively) than the 2-factor model (859.94, .458, and .278 on chi-square, TLI, and RFI measures respectively) and 1-factor model (901.54, .406, .246 on chi-square, TLI, and RFI measures respectively). The group of 12 year old children has defined the 8-factor model more (785.02, .455, and .271 on chi-square, TLI, and RFI measures respectively) than the 2-factor model (935.25, .323, and .192, on chi-square, TLI, and RFI measures respectively) and 1-factor model (1026.81, .196, and .117 on chi-square, TLI, and RFI measures respectively). These means the respondent children are able to differentiate the eight dimensions (appearance, ability, peer, parental, math, reading, school, and general) of self-concept than the two dimensions (academic and nonacademic) and one dimension (general self). This data also imply that in all measures 2-factor model better fits to the data than the 1-factor model in all age groups and in total sample. This means the respondents are able to differentiate the two dimensions of self-concept (academic and nonacademic) than one general self-concept.

When the age groups are compared regardless of significance level, we will see how the three models differentially fit to the different age groups that is how age influences the ability of differentiating the three hierarchies and respective dimensions of self-concept as follows (see table 3). For the 1-factor model 12 year group has higher values of fit on chi-square than 8 to 9 year group but less than 10 to 11 year group. When we come to TLI and RFI, 12 year group is the least and 8 to 9 years are the highest. As to the two factor model 12 year group has higher fit on chi-square than 8 to 9 year group but less than 10 to 11 year group. With regard to TLI and RFI, in this model, higher fit inversely get stronger with age.

The 8-factor model fits the responses of 12 year olds secondly following 10 to 11 year olds' on chi-square. TLI shows highest fit for 10 to 11 year olds followed by 8 to 9 year group. As to RFI the strength in fit is inversely stronger with age. It is only in chi-square that the models fit the data consistently higher for the higher age groups ('10-11' and 12 year olds, though the former is greater) than the lowest age groups that is 8 to 9 year olds.

In differentiating the factors, namely the general self-concept, academic and nonacademic aspects of self-concept, and the 8-factors of self-concept increase in age is not supported to be a dependable indicator of increased ability in differentiating the constructs – especially on TLI and RFI measures.

When chi-square measures are taken separately, however, it gives the impression that increase in age supports to be able to differentiate the hierarchies and dimensions of self-concept.

The measure of fit of the 8-factor model have not shown consistent increasing pattern with age makes it inconclusive as to whether children increasingly better differentiate the eight self-concept dimensions. This result may be induced by the relatively smaller size of the sample in each age group than earlier studies in other cultures.

Generally, the best fit of the models is shown by the 8-factor model on measures of TLI. Based on .90 guide line as a criterion of a "good" fit, the fit of the 8-factor a priori model is closer to good for the total sample (.860). It is less than good, while it is significant, for the children of ages '8-9 years' (.515), and '10-11 years' (.517). It is insignificant for '12 years' (.455) seen separately.

Table 3: Goodness of Fit Indices for Alternative Models for Children Ages of ‘8 to 9’, ‘10 to 11’, ‘12 years’, and for the Total Sample (TOT)

Model	DF	Chi-Sq	TLI	RFI
<b>Null Models *</b>				
8 to 9 years	496	1641.12	.000	.000
10 to 11 years	496	1259.08	.000	.000
12 years	496	1224.29	.000	.000
TOT	496	2275.95	.000	.000
<b>1 Factor Models</b>				
8 to 9 years	471	1047.34	.470	.328
10 to 11 years	471	901.54	.406	.246
12 years	471	1026.81	.196	.117
TOT	471	1005.12	.684	.535
<b>2 Factor Models</b>				
8 to 9 years	469	999.70	.510	.356
10 to 11 years	469	859.94	.458	.278
12 years	469	935.25	.323	.192
TOT	469	815.43	.794	.621
<b>8 Factor Models</b>				
8 to 9 years	436	924.23	.515	.359
10 to 11 years	436	759.68	.517	.314
12 years	436	785.02	.455	.271

TOT                      436                      655.67                      .860                      .672

*Note: Chi-Sq = Chi-square, TLI = Tucker-Lewis Index, RFI = Relative Fit Index.*

*\* The null model posits that all of the measured variables are uncorrelated, and is used to define the (poorest fitting) endpoint for the TLI and the RFI.*

#### **4.2.2 Parameter estimates**

The evaluation of the factor loadings (see Table 4) for each age group and the total sample for the 8-factor a priori model shows that all 8 factors are distinctly demonstrated. In the analysis most of the factor loadings are statistically significant and the largest parts are substantial in size. Nevertheless, the mean factor loading is larger for younger children.

Because of the concern as to in which part of the questionnaire the quality of the responses is high and for which age group, especially because the questionnaire is a bit long, a test of the factor loadings was carried out. The result of the comparison of the factor loadings (Table 4) from the first half of the SDQI with those from the second half provides the following. The sizes of the factor loadings for the first two indicators are systematically higher than those for the last two indicators, and the size of this difference is larger for the oldest children. These results suggest that particularly for the children of age 12 the initial responses were systematically more effective than those of subsequent responses that there was apparent deterioration in responses near the end of the SDQI. This gives an indication that the children may have felt fatigue towards the end of the questionnaire that may be a concern in administering the questionnaire.

The extents of factor correlations give one indication of how significantly children are capable of distinguishing the 8 factors. With regard to the size of the factor correlations in CFA, these are correlations among latent constructs (facets) which are corrected for unreliability. Though the mean correlations among factors for all of the age groups were substantially small; there is a consistent pattern in the relative sizes of the correlations.

For all three samples the highest correlations involve the Math and School scales. Specifically, the Math scale is consistently correlated most highly with General Self, Reading, and the School scales, whereas the School scale is also highly correlated with the Reading and General Self scales. The result

appears supporting that general self-concept is more affected by school and math self-concepts. This means children evaluate themselves in general highly by the rating they give to their school and math ability. Reading seems to affect and affected by school and math self-concepts. When the total sample is seen (see Table 7 below) the highest correlation is between Ability and Peers and most related to general self is Peer relation followed by Math.

The size of uniquenesses represents the specific variance and error variance in each measured variable that cannot be explained in terms of the 8 a priori factors. Consistent with results already discussed, the sizes of the uniquenesses decrease systematically with age (Table 4). This shows that the respondents increasingly similarly rate themselves.

Table 4: Summary of Parameter Estimates for Confirmatory Factor Analyses of the Three Age Groups and the Total Group for the 8-factor A Priori Model

Measured Variables	Factor Loadings			
	8-9 years	10-11 years	12 years	Total Group
<b>Appearance</b>				
1	.63	.50	.88	.67
2	.85	.56	.89	.82
3	.67	.23	.45	.57
4	.79	.71	.79	.76
<b>Ability</b>				
1	.64	.65	.66	.61
2	.79	.14	.12	.38
3	.72	.59	.64	.74
4	.73	.37	.89	.69
<b>Parents</b>				
1	.56	.74	.54	.67
2	.56	.82	.77	.71
3	.72	.62	.44	.62
4	.64	.75	.67	.71
<b>Peers</b>				
1	.51	.65	.00	.42
2	.58	.31	.43	.48

3	.73	.76	.34	.71
4	.44	.84	.62	.67
School				
1	.56	.27	.57	.55
2	.37	.54	.64	.56
3	.59	.65	.60	.64
4	.76	.78	.76	.78
Read				
1	.69	.56	.28	.59
2	.72	.30	.48	.63
3	.58	.80	.97	.77
4	.69	.72	.69	.78
Math				
1	.58	.40	.63	.63
2	.62	.60	.76	.67
3	.64	.66	.93	.75
4	.72	.77	.81	.82
General				
1	.69	.01	.45	.59
2	.59	.48	.44	.58
3	.65	.23	.35	.57
4	.83	.46	.54	.71

Mean Factor Loading	.65	.55	.59	.65
Mean Factor Correlation	.44	.34	.40	.43
Mean Measured Variable				
Uniqueness	.44	.39	.36	.41

**Note :** For the 8- factor a priori model, each factor is inferred on the basis of four measured variables. Each measured variable was allowed to load on only the factor that it was designed to measure and all other factor loadings were constrained to be zero. The factor loadings from each analysis are shown as a single column even though they represent 8 different factors. Most of the factor loadings are statistically significant. The means of factor correlations and measured variable uniquenesses are presented.

Mean factor correlation decreased from .44 in 8-9 year olds to .34 in 10-11 year olds, though it slightly increased in 12 year olds (.40). This may imply that children differentiate factors increasingly with age. This means they increasingly discriminate among the variables of the the scales of the instrument.

### **4.2.3 The Harter Model**

Harter and Pike (cited in Marsh et al, 1990, 2000) used four scales (namely, social, maternal, physical, and academic scales) to measure self-concept. Since these 4 scales correspond most closely to the Peer Relationships, Parent Relationships, Physical Ability, and School scale of the SDQI (based on comparison of content of scales), Marsh et al (1990) used them and found out that children as young as 5 to 8 years identified all the factors. Similarly in the study, based on confirmatory factor analysis, the three different models were fit to the responses to these SDQI scales with; a one-factor model in which all variables loaded on one (general) factor, a two-factor model in which they loaded on two factors, and a four-factor model in which each of the 4 scales defined a separate factor.

Similar to the findings above based on Shavelson's (Shavelson and Bolus, 1981; also cited in Marsh et al, 2000, 1990) hierarchical and multidimensional self-concept three models of self-concept, all of the three of Harter's models were fit to the data for the total sample of children in the community. It also fits the data of all individual groups particularly as supported by TLI measures, with the exceptions of

12 year olds for 1-factor and 2-factor models. RFI also demonstrates all the models significantly fit all total samples.

The significant fit the 1-factor, 2-factor and 4-factor models show to the total group are particularly indicated by TLI (.815) and RFI (.676) for one factor model; by TLI (.811) and RFI (.673) for two factor model; and by TLI (.986) and RFI (.817) for 4-factor model. This supports the hierarchical and multidimensional nature of self-concept for the total group. Even if it is only the 4-factor model that have 'good fit' all fulfill the requirements of significant fit that is .5 on measures of TLI and RFI.

For each age group and for the total sample, the Harter and Pike (one-factor) model performed marginally better than the two-factor model (see Table 5) but substantially poorer than the four-factor model. The advantage of the four-factor model over the one and two-factor models was positively related to the age of the children. This is in line with earlier findings. These findings imply that self-concept is differentiated among the subjects of this study when tested by the Harter and Pike instrument.

The 1 factor model is nearly good fit (.815) on TLI in the total sample while it is significant (.676) on RFI. On chi-square it is fitted most for 8 to 9 year olds followed by 12 year olds. Children of 8 to 9 year olds have more fit followed by 10 to 11 year olds on both TLI and RFI.

The two factor model also nearly fit (.811) on TLI for the total sample while it is significant (.673) on RFI. As to chi-square measures 12 year olds show the best fit for the model followed by 8 to 9 year olds. Similar to the one factor model children of 8 to 9 year olds have more fit followed by 10 to 11 year olds on both TLI and RFI.

In the 4 factor model, the total group demonstrated highly good fit (.986) on TLI and nearly good fit (.817) on RFI. With regard to chi-square the respondents show successively increasing fit to the model as age category of the groups increases. In this model 10 to 11 year olds show highest fit followed by 12 year olds on TLI and the group of 8 to 9 year olds demonstrate highest fit followed by 10 to 11 year olds on RFI.

Thus, the findings again indicate that the models fit to the data sufficiently that means the respondents are able to differentiate the one general factor, the two factors (acceptance and competence), and the four factors (Peer Relationships, Parent Relationships, Physical Ability, and School). As to the effect of age it is only on chi-square measure that the 2 factor and 4 factor models showed the highest fit for

the oldest groups that is 12 year olds that implies the children differentiated more dimensions of self-concept as their age increased. The other two measures, however, show results that are incompatible with the theories that maintain that children's ability of differentiating self-concept dimensions increases with age.

Table 5: Goodness of Fit Indices for Alternative Models for Children in Ages of '8 to 9', '10 to 11', '12 years', and the Total Sample (TOT) Based on the Harter and Pike (1984) Model

Model	DF	Chi-Sq	TLI	RFI
Null Models *				
8 to 9 years	120	396.91	.000	.000
10 to 11 years	120	344.79	.000	.000
12 years	120	272.55	.000	.000
TOT	120	703.52	.000	.000
1 Factor Models				
8 to 9 years	107	177.77	.713	.498
10 to 11 years	107	185.16	.610	.398
12 years	107	181.07	.455	.255
TOT	107	203.23	.815	.676
2 Factor Models				
8 to 9 years	105	175.45	.709	.495
10 to 11 years	105	182.44	.606	.395
12 years	105	172.13	.497	.278
TOT	105	201.57	.811	.673

#### 4 Factor Models

8 to 9 years	98	150.73	.767	.535
10 to 11 years	98	134.53	.801	.522
12 years	98	126.88	.768	.430
TOT	98	104.86	.986	.817

#### Note:

- *Chi-Sq = Chi-square, TLI = Tucker-Lewis Index, RFI = Relative Fit Index. The 4 SDQI factors (Physical Ability, Peers, Parents, School) that most closely match those proposed by Harter and Pike (cited in Marsh et al, 1990) are considered in models summarized here.*
- *The two factor model corresponds to the model proposed by Harter and Pike in which one factor (competence) incorporates the Physical Ability and School scales, whereas the second (acceptance) incorporates the Peers and Parents scales.*

\* *The null model posits that all of the measured variables are uncorrelated, and is used to define the (poorest fitting) endpoint for many of the goodness of fit indices.*

#### **4.2.4 The assessment of the 8 factor model**

It was essential to establish the reliability and validity of the factors to complete the examination of the 8 factor confirmatory factor analysis model. The various reliability and validity items that we have checked and reported in this study were summarized below in Table 6.

Accordingly, most of the indicators have individual indicator reliability values that are much larger than the minimum acceptance level of .4 and closer to the preferred level of .7 (Ken Kwong-Kay Wong, 2013). Composite Reliability was used instead of Cronbach's alpha to measure internal consistency reliability of the factors as the latter tend to provide a conservative measurement (Hair et al., 2012). As a result, Composite Reliability values were shown to be larger than .6, so high levels of internal consistency reliability have been demonstrated among all eight factors.

To check convergent validity, each factor's Average Variance Extracted (AVE) was evaluated. It was found that a half of the AVE values are greater than the acceptable threshold of 0.5, so convergent validity is partly confirmed (Ken Kwong-Kay Wong, 2013).

Table 6: Indicator Reliability and Validity Measures for the 8 Factor Model

Factors	Indicators	Loadings (1)	Indicator Reliability (1 <sup>2</sup> )	Composite Reliability	AVE
Appearance	AP1	.67	.45	.800	.504
	AP2	.82	.67		
	AP3	.57	.32		
	AP4	.76	.58		
Ability	PH1	.61	.37	.703	.384
	PH2	.38	.14		
	PH3	.74	.55		
	PH4	.69	.48		
Parental	PA1	.67	.45	.770	.457
	PA2	.71	.50		
	PA3	.62	.38		
	PA4	.71	.50		
Peers	PE1	.42	.18	.666	.343
	PE2	.48	.23		
	PE3	.71	.50		
	PE4	.67	.45		
School	SS1	.55	.30	.732	.411
	SS2	.56	.31		
	SS3	.64	.41		

	SS4	.78	.61		
Reading	RE1	.59	.35	.788	.485
	RE2	.63	.39		
	RE3	.77	.59		
	RE4	.78	.61		
Math	MA1	.63	.39	.811	.520
	MA2	.67	.45		
	MA3	.75	.56		
	MA4	.82	.67		
General Self	GE1	.59	.35	.706	.377
	GE2	.58	.34		
	GE3	.57	.32		
	GE4	.71	.50		

Fornell and Larcker (1981) suggest that the square root of AVE in each factor can be used to establish discriminant validity, if this value is larger than other correlation values among the factors. To do this, a table was created in which the square root of AVE is manually calculated and written in bold on the diagonal in Table 7. The correlations between the factors are copied from the “Correlations” section of the default report in AMOS and were placed in the lower left triangle of the table. As it can be seen from the table, the square roots of AVE for all of the factors was found to be smaller than the correlation values in their respective columns as well as rows. Thus, the result indicated that discriminant validity was not well established.

Overall, indicators (parcel items) and factors are found to be reliable in this study while discriminant quality of the items has shown to be relatively weak.

Table 7: Fornell-Larcker Criterion Analysis for Checking Discriminant Validity

	Math	Appearance	Ability	Parents	Peers	School	Read	General
Math	<b>.721</b>							
Appearance	.531	<b>.710</b>						
Ability	.481	.758	<b>.620</b>					
Parents	.675	.792	.623	<b>.676</b>				
Peers	.594	.814	.967	.801	<b>.586</b>			
School	.957	.609	.410	.749	.596	<b>.641</b>		
Read	.803	.382	.297	.722	.523	.887	<b>.696</b>	
General	.858	.714	.748	.743	.899	.773	.745	<b>.614</b>

#### 4.2.5 Sex and Age Effects

In this study, a repeated measures ANOVA was used to evaluate the effects of age (8-9, 10-11, and 12 years) and sex across the 8 SDQI scales. When total self-concept that is averaged across all 8 scales (i.e., the main effect of the repeated measure variable) is assessed the effects of age was significant while, the effect of sex and their interaction were non-significant. Nevertheless, each case demonstrated that the sizes of these effects varied considerably depending on the SDQI scale. In order to investigate the effect of each one of the scales tests of simple main effects were used (Table 8).

Here age was considerably related to five SDQI scales: Peer Relations, School, Reading, Math, and General Self. In these scales only the linear effect of age was significant and the direction of the effects was positive. The outcome of sex was statistically significant only for one SDQI scale i.e. Peer Relations. Girls had modestly lower self-concepts of Physical Ability and Reading, and substantially higher self-concepts in Physical Appearance and Peers. There was also an age by sex interaction for Reading and Math. Boys had higher self-concepts at oldest ages, the sizes of the sex differences decreased with age.

Table 8: Sex and Age Effects in the SDQI Scale

SDQ Score	Sex	Age of Children			Effect Size and Statistical Significance		
		8-9 years	10-11 years	12 years	Age	Sex	Sex by Age
Appearance	Boys	35.58	31.91	30.71	.07	.03	.03
	Girls	34.74	34.18	33.52			
Ability	Boys	35.68	31.73	32.71	.04	.004	.07
	Girls	33.68	35.18	32.68			
Parents	Boys	39.47	35.82	36.05	.05	.01	.05
	Girls	38.11	38.45	36.86			
Peers	Boys	36.21	31.73	31.43	.13*	.07*	.06
	Girls	36.32	36.14	32.95			
School	Boys	42.58	37.64	39.29	.21*	.001	.02
	Girls	43.42	38.82	38.14			
Reading	Boys	43.74	37.86	43.52	.15*	.003	.09*
	Girls	43.05	40.64	40.14			
Math	Boys	41.26	35.91	40.24	.13*	.01	.09*
	Girls	42.84	40.00	37.24			
General	Boys	42.16	37.09	38.62	.10*	.00	.08
	Girls	40.53	40.36	37.05			
Total Scores							
Total Self	Boys	39.59	34.96	36.57	.15*	.01	.07
	Girls	39.09	37.97	36.09			

\* $P < .05$

### **4.3 Responses in the focus group discussions**

Participants of two focus group discussions, one composed of fathers and the other mothers, gave the following responses. The questions focus on whether children differentiate the eight dimensions of self-concept and how their ratings are, comparing 8 years and 12 years of age children. The first question raised in each of the discussions was that “do children comment about their physical ability and physical appearance and how do you think children of around 8 years rate their physical ability and physical appearance as compared to children of 12 years of age?”

The parents explained that the problem is that they do not as such attentively follow up the self-concept situation of their children. According to them, however, as they judge from their utterances and actions, children of 8 and 9 years of age think and comment about their physical ability and appearance. The children have understandings about their physical situation because the parents carry out various care and socialization activities that instills such understanding in the children, according to them.

In their culture parents advise their children about how to control himself/herself while being out side, and how to work. They make efforts to provide nourishment to their children so that they would have better physical abilities. Since children of age 8 fetch water, clean house, make coffee, watch over cattle or participate in other household chores they have ideas about their physical abilities. Children of 12 years participate in more demanding physical activities like cutting grain or digging ground that gives them more conception of the physical self. As to rating oneself the younger ones have the habit of saying “I can do” that declines with age, the participants affirmed. The responses of the participants indicated that children as young as 8 years old differentiate their physical ability self-concept and younger children have the habit of exaggerating their abilities. The participants think that male children have more physical conception because they are encouraged and taught more physically demanding activities.

As to physical appearance, the participants were restricting themselves to give comments. Among some comments they managed to give are that children of their area rate their appearance depending on the family they are brought up. It is also believed that beauty is gift of God that children are not expected to bother about their appearance. On the other hand some responded that children are advised

and supported to feel good about their appearance like by giving cosmetics for a girl of as young as 7 years old, giving a bath, cutting hair and providing clean sleeping place are among the care that parents provide that they believe it helps children have good feelings about their appearance. Children as young as 8 may give comments as to their appearance if their parents encourage them. Among children there is not the habit of saying “I am beautiful” regardless of age. There is also the tradition of scolding a child especially if he or she is too short, too long or has short nose that may lead children to think they are not attractive. As to rating oneself the younger children may sometime boast about their appearance. The older children do not boast about their appearance.

The second question raised in each of the discussions was that “do children comment about their relation with their parents and peers and how do you think children of around 8 years rate their relation with parents and peers as compared to children of 12 years of age?” They responded that they believe that children of these ages think of their relation with parents and peers, though the older ones may be more elaborate relation with peers. With regard to relations to parents the participants explained that younger children, like 8 year olds, have more relations and proximity with parents, unlike children of older ages like 12 years of age who distant themselves from parents. So they explicated that, even if both children have a certain conception of their parents, they think younger children may think that they have good relation with parents while the older ones may feel less relation. As to peer relation, children have a mixed type of relation; there is peaceful as well as conflictual relation. Parents of the area usually advise them (especially the younger ones) to get along with peers, not to quarrel and to have good friends. Parents sometimes punish their children to make them comply with rules in this regard. The older children, like that of 12 year olds, are relatively free to choose their friends and to manage their relation. The participants responded that they think that both the younger and the older children have mixed type of ratings as to their relationship with peers. There was not significant answer given by them as to the existence of exaggeration and decline of self concept with age in this regard.

The third question raised in each of the discussions was that “do children comment about their math, reading, and school interests and abilities and how do you think children of around 8 years rate their ability in these regard as compared to children of 12 years of age?” The participants responded that understanding the self-conceptions of children with regard to school subjects depends on parents educational status that most of them explained that they do not follow up their children in this regard as to how they feel and do about their particular school subjects. Some, however, explained that since

attending education is mandatory children go to school that it is inevitable they have some conceptions about their school and school subjects. They, however, commented that they do not think most children feel competent with regard to their school subjects because, as they are rural children they also participate in agricultural activities of their families, they do not devote much time to attending education and studying that makes them feel less capable with regard to education. Although they register at the beginning of semesters, regular attendance of education is rarer among younger children, like that of 8 year olds, than the older ones, like that of 12 years of age, because of the hardship involved in walking long distances to school on foot. As to general self-concept there was not a definite answer given by the participants.

## **4.4 Discussion**

In this study it is intended to discover whether the Self Description Questionnaire I scales and the 8 factors are valid and reliable in the responses of the respondents. It investigates the SDQI for assessing multiple facets of self-concept for children in the Amhara culture. It is also intended to find out whether theories of self-concept development can be extended in the culture.

### **The Self Description Questionnaire I**

The main finding of the study is that reliability and factor structure of the Self Description Questionnaire I scales is established by the responses. There is support for the use of the SDQI that is standardized for children of 8 to 12 years old children (though it is also used for children of varied age ranges from 5 to 14 years old children in various studies around the world) on children of the same age range in the Amhara community. The Self Description Questionnaire I scales and the 8 factors are valid and reliable in the responses of the respondents. Internal consistency reliability estimates based on Cronbach's alpha reliability statistics show that there is significant estimate in each age group. As an exception, children of 10 to 11 years of age did not consistently respond to items that demanded answers for physical ability. Even if it is significant, children of 10-11 years age have manifested the relatively lower reliabilities to reading and general self items. Children of age 12 have shown the relatively lower reliability for general self and parental relation. The 10 – 11 and 12 year olds have given lower reliable responses for general self. The reliability median estimates, though it is highest for the youngest group (.781), it has shown increment with age (because it increased from .705 for 10-11 year olds to .727 for 12 years old students).

SDQI, an instrument of measurement of self-concept, is evaluated as to its validity and reliability in Amhara culture in Ethiopia so that various theories the instrument is supposed to examine can be tested. It is found out that the SDQI instrument is psychometrically strong that self-concepts of the children in the culture can be studied giving results that are dependable to conduct further research or make interventions based on findings. Reliability of the Self Description Questionnaire I scales is established that means the children mostly have consistently responded to questions of the scales.

Children of 10 to 11 years of age did not consistently understand the questions of physical ability may be due to increasing doubts as a result of the new developments in middle childhood of muscular growth and better coordination that enable the children to do more physically demanding activities and acquire other skills that entail greater strength or precision than what they used to do when they were younger.

Children of age 12 have shown the relatively lower reliability for general self and parental relation. The 10 – 11 and 12 year olds have given lower reliable responses for general self that may show they have problems in consistently rating their self-worth. This may contrast with Harter's theory that as children pass the age milestone of 8 year they would have an increasingly clear perception of their general self. The 12 year olds have less reliable rating as to their parental relation which may be due to the approaching adolescence that may have shaken their consistent sense of harmony with parents.

Generally, except the physical ability scale for 10 to 11 year group, the internal consistency estimates provide reasonable support for the SDQI. The reliability median estimates, though they are highest for the youngest group, they have shown increment with age. This may show better reliability of responses as children increase in age. Overall, the internal consistency estimates provide reasonable support for the SDQI and factor structure of the self-concept responses.

According to results of another study on younger children by Marsh et al (1990, 2000), there is an apparent practice effect such that items from the last half of the SDQI were more effective than items from the first half that was larger for younger children. The authors explained that this may be a result of a practice effect that as children were able to master the questions as a result of practice they were able to respond effectively more at the end than the beginning. In this study, though the subjects are relatively older, just the opposite happened. The sizes of the factor loadings for the first two indicators are systematically higher than those for the last two indicators, and the size of this difference is larger for the oldest children. These results suggest that particularly for the children of age 12 years the initial responses were systematically more effective than those of subsequent responses that there was apparent deterioration in responses near the end of the SDQI. This may be because effect of fatigue.

The validity and reliability of the SDQI instrument highly contributed for most of the findings in this study to by and large conform to what is stipulated in the theories of self-concept that are investigated in this study.

## **Self-concept is multidimensional and hierarchical**

According to the finding, the self description questionnaire I scales have a consistent factor structure with other studies. The factor structure, as implied by pattern of factor loadings, of the questionnaire found with children of another culture is replicated in the responses confirms the multidimensionality of self-concept among the subjects who are members of Amhara culture. This imply that each of the 8 SDQI factors identified in responses by children of another culture were identified here, indicating that self- concept factors are defined and distinct for these children.

The hierarchical and multidimensional structure of self-concept of children is demonstrated as stipulated by the three a priori models. Based on the hypothesis of the three models there are three types of hierarchical factors composed of one general factor, two factors that encompasses an academic and nonacademic factor; and 8 factors at the base of the hierarchy in line with the 8 SDQI scales. The models were fit to the data of the total sample and to some of the age groups independently. The values in the analyses show that there is significant fit that the 1-factor and 2-factor models show to the total group; the 8-factor model is closer to good fit for some measures to the total sample.

Evaluation of all the measures indicate the a priori 8-factor model, which is consistent with the design of the SDQI, fits the data substantially better than the 1-factor or 2-factor models. The two factor model fits the data better than the one factor model. The results apply both for total group and for each age group taken separately. The finding that all the models significantly fit the data of the total sample supports the hierarchical nature of self-concept. This is a similar result to other studies in other parts of the world. In a study on Mexican American children using SDQI, for instance, the classic hierarchical SDQI factor structure is supported (Kaminski et al, 2005).

The fit of the 8-factor a priori model is closer to good for the total sample, while it is less than good for individual groups of the children. When the 8-factor model is able to fit the data reasonably well it provides evidence for the design of the SDQI. It is right to make parameter estimates based on the 8 factor model because it fits the data significantly better than the 1-factor and 2-factor models.

The evaluation of the factor loadings for each age group considered separately and for the total sample for the 8-factor a priori models shows that all 8 factors are distinctly demonstrated. In the analysis most of the factor loadings are statistically significant and the largest parts are substantial in size. Nevertheless, the mean factor loading is larger for younger children. The lower extents of factor correlations gave an indication of how significantly children are capable of distinguishing the 8 factors.

This study also supported the multidimensionality of self-concept of the respondents using other instrument, namely Harter's scale; its difference with the Self Description Questionnaire I is that it provides narrower variety of self-concept domains. In this scale, Harter and Pike (cited in Marsh et al., 1990) developed a four factor model that includes school, physical, maternal acceptance, and social acceptance.

The hierarchical and multidimensional feature of self-concept is demonstrated by the Harter model. As the 4 scales of the model correspond most closely to the Peer Relationships, Parent Relationships, Physical Ability, and School scale of the SDQI, this study, based on confirmatory factor analysis, investigated the three different models; a one-factor model in which all variables loaded on one (general) factor, a two-factor model, and a four-factor model and found out that each of the 4 scales defined a separate factor that fit responses to the SDQI scales.

All of the three of Harter's models significantly fit data of the total sample (imply hierarchical nature of self-concept) and most of the age groups, especially on TLI measures. For each age group and for the total sample, the Harter and Pike (one-factor) model performed better than the two-factor model but substantially poorer than the four-factor model. The advantage of the four-factor model over the one and two-factor models was positively related to the age of the children. This is in line with earlier findings. These findings imply that self-concept is differentiated among the subjects of this study when also tested by the Harter and Pike model.

Thus, children of the Amhara culture in the target area are able to differentiate among multiple dimensions of self-concept providing support for cross cultural applicability of the theory. This result is similar to responses by children in other cultures to appropriately constructed self-concept instruments (Harter, Marsh cited in Marsh et al, 1990); in these studies factor analyses have identified the factors that such instruments are designed to measure. In other Western study (Marsh, 1984) children in grades two to five (the age range is similar to that of the subjects of this study) evidently recognized the seven SDQ factors, as found out from the factor analyses of responses to the Self-Description Questionnaire (SDQ). In a similar study that was administered to primary school students from Sydney, Australia, *factor analyses of responses clearly demonstrated the seven factors that the SDQ is designed to measure* (Marsh et al, 1981).

In studies on similar age children by Marsh et al (1984, 1989), correlations among factors were in line with Shavelson's model that children precisely categorized factor structures. In a study on Mexican American children using SDQI the factor structure of the Self-Description Questionnaire-I is supported (Kaminski et al, 2005). Analysis of responses of Lithuanian 12–14 year-old children to SDQI also supported the internal consistency and factor structure of the questionnaire (Watkins et al, 1995).

Marsh et al (1990, 2000), conducting such studies on younger children (who are 5 to 8 years of age) in Sydney, Australia, found out that self-concept is multidimensional. They differ from this study in that they administered the questionnaires individually and made it suitable to the ages of the children. Studying the same children applying the instrument of Harter and Pike, Marsh et al (2000) based on the four scale of the instrument, supported the ability of the children to differentiate the four factors, namely academic, physical, parental relation, and peer relation, in addition to the eight factors identified by their instrument, namely SDQI.

With regard to the qualitative data, the responses given by parents that participated in the focus group discussions assured that children of 8 to 12 years of age in their area differentiate most of the dimensions of the self-concept that are contained in the SDQI. They responded that these children more or less differentiate and evaluate themselves by the aspects of self-concept, though there might be differences in age and individual differences.

The analysis of this study shows that children of the Amhara culture are cognitively capable of distinguishing among the different dimensions of self-concept that are on the SDQI. These studies, however, need to be widely done in Ethiopian cultures that would enhance the chance of extending the theory of multidimensionality of self concept, particularly in middle childhood thereby further studies would be conducted on the different facets of self-concept development.

Some researchers, particularly Harter (cited in Marsh et al, 2000) contend that the general self scale is able to be defined after children reach age 8. The responses in this study have also defined the general self factor. General self-concept (self-esteem that is first-order factor) is well integrated with first-order factors and the hierarchical third-order general self-concept. It is well defined in the total sample and the youngest age range considered in the present investigation. This result is similar to studies

elsewhere on children under the age groups considered here and who are in parallel age (Marsh et al., 1990, 2000).

In this study the General self scale was reasonably reliable for each age group. CFA of responses of the total sample and the youngest age group and responses for some measured variables identified the General self factor and the factor loadings were substantial (except for 10-11 age group). Furthermore, the correlations among the General scale and the other scales were consistently among the largest of any of the correlations.

### **Self-concept has increasing number of dimensions with age**

The other finding is that, though it is not convincing, consistent with the Shavelson et al. model, there is increasing number of dimensions with age and more specific data on how the factor structure of self-concept varies in the age range of 8 to 12 is provided. The measure of fit of the 8 factor model has not shown consistent pattern with age that makes it inconclusive as to whether children increasingly better differentiate the eight self-concept dimensions. Mean factor correlation, on the other hand, decreased from .44 in 8 to 9 year olds to .34 in 10 to 11, though it slightly increased in 12 year olds (.40). This may imply that children differentiate factors increasingly with age. This is consistent with the theory that as children's age increases they would be better able to differentiate the different facets of self-concept. The other substantiation for this result is the difference in fits of models. The models that comprise 1, 2, and 8 factors are found to become increasingly fit with age on chi-square measures (though it decreases with age on TLI and RFI measures). There is increasing fit with age for 4 factor model in tests of the Harter and Pike model.

This study indicates a mixed implication to the Shavelson et al. (cited in Shavelson and Bolus, 1981 and Marsh et al, 2000) hypothesis that as children's age increases self-concept becomes more differentiated. According to similar studies on children of similar ages, children are able to increasingly differentiate the dimensions of self-concept. Children of grades two to five, for instance were able to increasingly distinguish these factors with age (Marsh et al, 1984). In other cultures even children in preschool age were able to distinctively recognize the different aspects of self-concept increasingly with age using similar instruments (though with some modifications). Marsh et al (1990,

2000), for instance, conducting such studies on children of 5 to 8 years of age in Sydney, Australia, found out that aspects of self-concept were found to be more distinct as children increase in age.

The mixed type of result as to increment of differentiation of the different dimensions of self-concept with age in this study implies that more studies are needed with more number of samples.

### **The correlation pattern of self-concept factors**

The study tried to find out the correlation among the factors of self-concept among the respondents. Though the mean correlations among factors for all of the age groups were substantially small, there is a consistent pattern in the relative sizes of the correlations. For all three samples the highest correlations involve the Math and School scales. Specifically, the Math scale is consistently correlated most highly with General Self, Reading, and the School scales, whereas the School scale is also highly correlated with the Reading and General Self scales. These patterns imply that general self among the respondents is affected most by Math and School selves that is an indication that the students highly evaluate their self-worth in terms of their school performances and math. When the total group is seen it is ability and peer relation that have the highest correlation.

The size of uniquenesses represents the specific variance and error variance in each measured variable that cannot be explained in terms of the 8 a priori factors. Consistent with the results the sizes of the uniquenesses decrease systematically with age. This implies that the children are giving similar responses as their age increases.

### **Self-concept decline in middle childhood**

One of the theories with regard to self-concept development is that, as children acquire experience they increasingly understand their weaknesses and strengths so that their exaggerated self-ratings in early childhood begins to decline. This study tried to test this theory. According to the findings, the mean level of self evaluations increased with age which is contrary to what is stipulated in the theory. According to the qualitative finding, however, children's level of self ratings decrease as they complete their middle childhood years.

When the qualitative data is seen, as to decline of self-concept ratings with age, participants explained that children as old as 8 in their community have a tendency to overestimate their abilities, for example

to exaggerate their physical abilities, more than that of 12 year olds. This implies that self-concept declines as children increase in age.

### **The reliability and validity of the 8 factors**

Most of the indicators (item parcels) have individual indicator reliability values that are closer to the preferred level. Composite Reliability was used to measure internal consistency reliability of the factors. As a result, the Composite Reliability values show high levels of internal consistency reliability that have been demonstrated among all eight factors. Convergent validity among the factors is partly confirmed. Discriminant validity of the factors was not well established. This is a result similar to studies in other cultures. For instance, Marsh et al (1981) found out the construct validity of the questionnaire on children of 9 to 13 years of age (mean age = 11.04 years), based on seven scales (that is without including the general self scale).

### **Sex and age effects in self-concept**

The study evaluated sex and age effects in self-concept among the respondents, who are members of children of the Amhara community. As other studies in other parts of the world show age and gender affect self-concept development. As stated by Marsh et al (1990), studies show that *self-concept factors are systematically and logically related to a variety of other constructs including age, gender ...* This study evaluated the effects of age and sex across the 8 SDQI scales. When total self-concept that is averaged across all 8 scales is assessed the effects of age was significant, while the effect of sex and their interaction were non-significant.

Here age was considerably related to five SDQI scales: Peer Relations, School, Reading, Math, and General Self. In these scales only the linear effect of age was significant and the direction of the effects was positive. The outcome of sex was statistically significant only for one SDQI scale that is Peer Relations. Girls had modestly lower self-concepts of Physical Ability and Reading, and substantially higher self-concepts in Physical Appearance and Peers. There was also an age by sex interaction for Reading and Math. Boys had higher self-concepts at oldest ages (12 years), the sizes of the sex differences decreased with age. This result is similar to a finding in a survey in America on girls and boys between grades of 4 and 10 in 1991 (Greenberg-Lake, 1994). According to the study, as children approach adolescence the self-esteem of both girls and boys is highly affected. As stated by the survey, however, there are differences observed in levels of self esteem *between girls and boys, with more*

*boys than girls entering adolescence with high self-esteem.* Girls, who have high self esteem at the age of eight and nine, mostly self esteem begins to decline when adolescence commences and *emerge from adolescence with a poor self-image...*, according to the study. Even if similar finding appears to come out of this study more studies in Ethiopia may provide more data in this regard in the future.

Generally, this study supported the validity and reliability of SDQI in Amhara culture in children of the age for which it is designed to study self-concept. It found out the hierarchies and dimensions of self-concept among the sample children who are members of the community and its parameter estimate is significant. The validation of the SDQI instrument in children who are in different cultures helps to extend theories and to understand practical implications with regard to self-concept. The progress in self-concept theory and practice in the West is a result of development of psychometrically strong instruments like the SDQI thereby finding out of hierarchical and multiple facets of self-concept and their developmental features. Self-concept of Ethiopian children needs to be studied further by formulating and validating important instruments like the SDQI and testing various theories. As self-concept development commences in the early ages of children, age and culturally valid instruments need to be devised and used in studies that are conducted to validate various theories of development.

# **Chapter V**

## **Summary and Conclusions**

### **5.1 Summary**

After investigating whether the SDQI scales and the 8 factors are valid and reliable in the responses and if theories of self-concept development can be extended in the Amhara culture the following are found out.

Reliability and factor structure of the Self Description Questionnaire I scales is established by the responses that supports the use of the SDQI on children of the Amhara community; the scales and the factors are valid and reliable in the responses. Internal consistency reliability estimates dominantly show significant estimate in each age group. The reliability median estimates have shown some increment with age. The psychometrical strength of the SDQI in the culture is supported that makes it dependable to conduct further research or make interventions based on findings. Older children in the study shown lower reliability for general self and parental relation may be because they have problems in consistently rating their self-worth due to the approaching adolescence.

Since the SDQI instrument is psychometrically strong and it highly contributed for most of the findings in this study to go with what is stipulated in the theories of self-concept that are investigated in this study. The factor structure of the questionnaire found with children of another culture is replicated in the responses confirms the multidimensionality of self-concept among the subjects who are members of Amhara culture.

The hierarchical and multidimensional structure of self-concept of children is demonstrated as stipulated by the three a priori models, namely, one general factor, two factors; and 8 factors at the base of the hierarchy in which all the models were fit to the data of the total sample and to some of the age groups independently.

While the a priori 8-factor model, which is in line with the design of the SDQI, is the model that fits the data better than the 1-factor or 2-factor models, the two factor model fits the data better than the

one factor model both for total group and for each age group. The finding that all the models significantly fit the data of the total sample supports the hierarchical nature of self-concept.

The finding that the 8-factor model is the best fit model is an evidence for the design of the SDQI. That is why parameter estimates based on the 8 factor model is done in which the analysis shows that all 8 factors are distinctly demonstrated.

This study also supported the multidimensionality of self-concept of the respondents using other instrument, namely Harter's scale in which the four factor model has shown the best fit that is positively related to the age of the children that is in line with earlier findings.

Thus, children of the Amhara culture in the target area are able to differentiate among multiple dimensions of self-concept providing support for cross cultural applicability of the theory. According to the responses given by parents that participated in the focus group discussions, children of 8 to 12 years of age in their area differentiate most of the dimensions of the self-concept that are contained in the SDQI. Thus, the findings imply that children of the Amhara culture are cognitively capable of distinguishing among the different facets of self-concept that are on the SDQI.

The other point is that, while the General self scale was reasonably reliable for each age group, it is significantly defined in the total sample and the youngest age group considered in the present investigation. The correlations among the General scale and the other scales were consistently among the largest of any of the correlations.

The measure of fit of the 8 factor model has not shown consistently increasing pattern with age that makes it inconclusive as to whether children better differentiate the eight self-concept dimensions as their age increases. Mean factor correlation, however, somehow imply that children differentiate factors increasingly with age. This finding is also supported by that all models are found to become increasingly fit with age on chi-square measures and also there is increasing fit with age for the 4 factor model of the Harter and Pike model.

The mean correlations among factors for all of the age groups were substantially small. As to the relative sizes of the correlations for all three samples the highest correlations involve the Math and School scales. The patterns imply that general self among the respondents is affected most by Math

and School selves. With regard to the total group it is ability and peer relation that have the highest correlation.

The sizes of the uniquenesses decrease with age, which implies that the children are giving similar responses as their age increases.

According to the finding, the pattern of decreasing level of self rating of as children increase in age is not conclusively supported.

Most of the item parcels have good individual indicator reliability values, while composite reliability values show high levels of internal consistency reliability that have been demonstrated among all eight factors. While convergent validity among the factors is partly confirmed discriminant validity of the factors was not well established.

When total self-concept that is averaged across all 8 scales is assessed the effects of age was significant, while the effect of sex and their interaction were non-significant. In most of the scales only the linear effect of age was significant and the direction of the effects was positive. Girls had modestly lower self-concepts of physical ability and reading, and substantially higher self-concepts in physical appearance and peers. Boys had higher self-concepts at oldest ages (12 years).

## **5.2 Conclusions**

Based on the findings the following conclusions can be made. The Self Description Questionnaire I scales and the 8 factors are reliable in the responses of the respondents. The validity of the instrument is partially confirmed. The multidimensionality of self-concept in children of the Amhara community is established. The self description questionnaire I scales have a consistent factor structure and pattern of factor loadings and the factor structure of the questionnaire found with children of another culture is replicated in Amhara culture. As self-concept of the subjects is hierarchical, the increment of its dimensions with age is supported. As to the correlation among the factors of self-concept, while math and school facets shown the highest correlation in the individual groups physical ability and peer relation has shown highest relation in the total sample. There is no conclusive finding as to whether self-concept declines in middle childhood with age. There is significant age effect in self-concept as gender effect has less manifestation among the respondent children of the Amhara community.

## Recommendations

- In order to have a dependable research finding and support theories of self-concept of children instruments need to be developed and tested for their validity and reliability in various cultural contexts. Further studies need to be conducted in Ethiopia as to the validity and reliability of instruments to measure self-concepts of children in various cultures. Instruments like the SDQI, that measure several dimensions of self-concept, are essential, than instruments that focus on limited aspects.
- In spite of the importance of the traditional research on one general self-concept, researches on specific dimensions (contents) of self-concept need to be strengthened. This is because it is when every facet of self-concept is studied that children's specific problems can be identified and necessary interventions can be made.
- Children change in the level and type of self-concepts they have throughout their development. These changes depend on their cultural situation, information availability, and cognitive development. This needs closer study in Ethiopia to get contextually relevant data.
- Further studies need to be carried out as to what aspects of self-concept are related and affect each other in various cultures of Ethiopia. This is because one dimension of self-concept affects the other. The general perception of self worth may also be influenced by some domains than the others.
- To better understand self-concept development in middle childhood it requires understanding children's self concept in early childhood. As the basis of self-concept is laid down in earlier times of childhood, culturally appropriate instruments that measure self-concept of younger children need to be validated and developed. There are, for instance, instruments developed, particularly in the West, for very young children that incorporate pictures along with words or separately. Individual interviewing is an effective way of administering such types of instruments.
- As general self-concept in this study seems to be affected most by school related factors, the reasons for this need to be further studied by other researches.
- Since the decline or increase of level of self-concept rating with age is not conclusively supported in the targeted age groups future studies may clarify the antecedents behind this outcome.

## References

- Baumeister, R. F. (1987). How the self became a problem: A psychological review of historical research. *Journal of Personality and Social Psychology*, 52, I, 163-176. Doi: 0022-3514/87/\$00.75
- Broderick, P.C. and Blewitt, P. (2010). The Development of self-concept . *Education.com*. Retrieved from <http://www.education.com/reference/article/development-self-concept/>
- Cherry, K. (n.d). What is humanistic psychology? *The "Third Force" in psychology. Psychology.about.com*. Retrieved from [http://psychology.about.com/od/historyofpsychology/a/hist\\_humanistic.htm](http://psychology.about.com/od/historyofpsychology/a/hist_humanistic.htm)
- Chiu, M. (2013). Hierarchical models of self-concept across genders and sciences/humanities for college students in Taiwan. *Hindawi*, 2013, Article ID 960371, 9 pages.<http://dx.doi.org/10.1155/2013/960371>
- Craven, R. (2000). The structure and development of young children's self-concepts and relation to academic achievement. *Academia.edu*. Retrieved from [http://www.academia.edu/656019/The\\_structure\\_and\\_development\\_of\\_young\\_childrens\\_self-concepts\\_and\\_relation\\_to\\_academic\\_achievement](http://www.academia.edu/656019/The_structure_and_development_of_young_childrens_self-concepts_and_relation_to_academic_achievement)
- Demo, D. H. (1992). The self-concept over time: Research issues and directions. *Annual Review of Sociology*, 18, 303-326. Retrieved from <http://www.annualreviews.org/>
- Dumont, F. (2010). *History of personality psychology. Theory science and research from hellenist to the twenty first century*. New York: Cambridge University Press.
- Efrem Milkias. (1999). *Differences in self-esteem among high school students as a function of home environment and school performance in Sidama Zone*. (Master's thesis). Addis Ababa University, Addis Ababa.

Fornell, C. and Larcker, D.F., (1981). Evaluating structural equation models with unobservable variables and measurement error. *Journal of Marketing Research*, 18 (1), 39-50.

Greenberg-Lake: The Analysis Group. (1991). *Shortchanging girls, shortchanging America*. Washington, D.C.: American Association of University Women. Retrieved from <http://www.aauw.org/files/2013/02/shortchanging-girls-shortchanging-america-executive-summary.pdf>

Hair, J.F.; Sarstedt, M.; Ringle, C.M. and Mena, J.A., (2012). An assessment of the use of partial least squares structural equation modeling in marketing research. *Journal of the Academy of Marketing Science*, 40(3), 414-433.

Hau, K.; Kong, C.; and Marsh, H.W. (2000). Chinese student self-concept: validation of measurement and extension of theoretical models. In Rhonda G. Craven, and W. Marsh (Ed.), *Self-concept theory, research and practice: Advances for the New Millennium*. Sydney: Self-concept Enhancement and Learning Facilitation (SELF) Research Centre, University of Western Sydney. Retrieved from [http://www.uws.edu.au/\\_\\_data/assets/pdf\\_file/0007/374488/2000\\_Proceedings.pdf](http://www.uws.edu.au/__data/assets/pdf_file/0007/374488/2000_Proceedings.pdf)

Hoy, M. B. (2008). Self-concept. *International encyclopedia of the social sciences*. Retrieved from <http://www.encyclopedia.com/doc/1G2-3045302375.html>

Markus, H. R., and Kitayama, S. (1991). Culture and the self: Implications for cognition, emotion, and motivation. *Psychological review*, 98(2), 224-253. Retrieved from [http://www.psychwiki.com/wiki/Markus,\\_H.\\_R.,\\_%26\\_Kitayama,\\_S.\\_\(1991\).\\_Culture\\_and\\_the-self:\\_Implications\\_for\\_cognition,\\_emotion,\\_and\\_motivation.\\_Psychological\\_review,\\_98\(2\),\\_224-253](http://www.psychwiki.com/wiki/Markus,_H._R.,_%26_Kitayama,_S._(1991)._Culture_and_the-self:_Implications_for_cognition,_emotion,_and_motivation._Psychological_review,_98(2),_224-253).

Marsh, H. (n.d). Self Description Questionnaire I. Retrieved from [http://www.uws.edu.au/\\_\\_data/assets/pdf\\_file/0008/361871/SDQI\\_Inst.pdf](http://www.uws.edu.au/__data/assets/pdf_file/0008/361871/SDQI_Inst.pdf)

- Marsh, H.W. (1985). The hierarchical structure of self-concept: An application of hierarchical confirmatory factor analysis. Revision. Retrieved from <http://files.eric.ed.gov/fulltext/ED256773.pdf>
- Marsh, H. W. (1989). Age and sex effects in multiple dimensions of self-concept: Preadolescence to early adulthood. *Journal of Educational Psychology*, 81, 3, 417-30. Retrieved from <http://eric.ed.gov/?id=EJ399806>
- Marsh, H. W., Craven, R., and Debus, R. (1990). *Self-concepts of young children aged 5 to 8: Their measurement and multidimensional structure*. ED 319 789TM 015 C44
- Marsh, H. W.; Craven, R.; and Debus, R. (2000). Structure, stability, and development of young children's self-concepts: A multicohort-multioccasion study. In, W.Craig (ed.). *Childhood Social Development: Essential readings in developmental psychology* (pp. 221-272). Cornwall: Blackwell.
- Marsh, H. W., Barnes, J.; Cairns, L., and Tidman, M. (1984). Self-Description Questionnaire: Age and sex effects in the structure and level of self-concept for preadolescent Children. *Journal of Educational Psychology*, 76,5, 940-56. Retrieved from <http://eric.ed.gov/?id=EJ307790>
- Marsh, H.W.; Relich, J.; and Smith, I. D. (1981). *Self-concept: The construct validity of the Self Description Questionnaire*. Retrieved from <http://files.eric.ed.gov/fulltext/ED210306.pdf>
- Nuredin Mohammed. (2006). *Self-esteem of adolescents as related to parenting style and socio-economic status of parents: A study of high school students in Dessie*. (Master's Thesis). Addis Ababa University, Addis Ababa.
- Oosterwegel, A. and Oppenheimer, L. (1990). Concepts within the self-concept: A developmental study on differentiation. In L. Oppenheimer (Ed.) *The self-concept*

*European perspectives on its development, aspects, and applications* (pp. 9-22). Berlin: Springer-Verlag Berlin Heidelberg.

Oppenheimer, L. (1990). Introduction: Research on the self-concept- The State of the art in Eastern and Western Europe. In L. Oppenheimer (Ed.) *The self-concept European perspectives on its development, aspects, and applications* (pp. 1-8). Berlin: Springer-Verlag Berlin Heidelberg.

Rogoff, B. (2003). *The cultural nature of human development*. New York: Oxford University Press

Santrock, J. W. (1998). *Child development*. Boston: McGrawhill.

Strein, W. (1995). Assessment of self-concept. *ERIC Digest*. Retrieved from <http://www.ericdigests.org/1996-3/self.htm>

Shavelson, R. J. and Bolus, R. (1981). Self-concept: The interplay of theory and methods. *Journal of Educational Psychology*, 74, 1, 3-17. Retrieved from <http://www.rand.org/content/dam/rand/pubs/papers/2009/P6607.pdf>

Solomon Lemma. (1999). *Self-esteem, sex and family structures as predictors of academic achievement: The case of Sodo Comprehensive Secondary School students*. (Master's thesis). Addis Ababa University, Addis Ababa.

Triandis, Harry C. (1989). The Self and Social Behavior in Differing Cultural Contexts. *American Psychological Association*, 96, 3, 506-520. Retrieved from <http://bern.library.nenu.edu.cn/upload/soft/TheSelf.pdf>

University of Western Sydney. (2004). *New advances in self-concept research*. In *Bringing Knowledge to Life: New Archives*. Retrieved from [http://pubapps.uws.edu.au/news\\_archive/index.php?act=view&story\\_id=702](http://pubapps.uws.edu.au/news_archive/index.php?act=view&story_id=702)

- Wästlund, E.; Norlander, T.; and Archer, T. (2001). Exploring cross-cultural differences in self-concept: A meta-analysis of the Self-Description Questionnaire-1. *Cross-Cultural Research*, 35, 3, 280-302. Retrieved from [http://www-user.uni-bremen.de/~henning/public\\_html/public\\_html/Lehre/metaanalysen/Cross\\_Cultural\\_Self-Concept.pdf](http://www-user.uni-bremen.de/~henning/public_html/public_html/Lehre/metaanalysen/Cross_Cultural_Self-Concept.pdf)
- Watkins, D. (2000). The nature of self-conception: Findings of a cross-cultural research program. In Rhonda G. Craven, and Herbert W. Marsh (Ed.), *Self-concept theory, research and practice: Advances for the New Millennium*. Sydney: Self-concept Enhancement and Learning Facilitation (SELF) Research Centre, University of Western Sydney. Retrieved from [http://www.uws.edu.au/\\_\\_data/assets/pdf\\_file/0007/374488/2000\\_Proceedings.pdf](http://www.uws.edu.au/__data/assets/pdf_file/0007/374488/2000_Proceedings.pdf)
- Watkins, D; Juhasz, A. M.; Walker, A.; Janvlaitiene, N. (1995). The Self-Description Questionnaire-1: A Lithuanian application. *European Journal of Psychological Assessment*, Vol 11(1), 41-51. Retrieved from: <http://psycnet.apa.org/index.cfm?fa=buy.optionToBuy&id=1996-90973-001>
- Wong, K. K. (2013). Partial least squares structural equation modeling (PLS-SEM) techniques using smart PLS. *Marketing Bulletin*, 2013, 24, Technical Note 1
- Wylie, Ruth C. (1989). Measures of self-concept. *Questia.com*. Retrieved from: <http://www.questia.com/read/10565667/measures-of-self-concept>

# Appendix 1 Questionnaire

አዲስ አበባ ዩኒቨርሲቲ

ድህረ ምረቃ ፕሮግራም

የሳይኮሎጂ ኢንስቲትዩት

ዕድሜአቸው ከ6 እስከ 12 ዓመት በሆነ ልጆች የሚሞላ ራስን መግለጫ መጠይቅ አንድ (Self Description Questionnaire 1)

©

የሚሰጡን ማንኛውም መረጃ በጥብቅ ሚስጢርነት የሚያዝ ነው።

ስም \_\_\_\_\_ ጾታዎን በተመለከተ አንዱን ይክበቡ፣ ወንድ \_\_\_\_\_ ሴት \_\_\_\_\_

ትምህርት ቤት \_\_\_\_\_ ክፍል \_\_\_\_\_ ዕድሜ \_\_\_\_\_

ቀን \_\_\_\_\_

**እባክዎን የሚከተሉትን የመልስ አሰጣጥ መመሪያዎች በጥንቃቄ ያንብቡ።**

ይህ ፈተና አይደለም፣ ትክክለኛና ስህተት የሆነ ምላሽ የለም።

ይህ መጠይቅ ራስዎን በራስዎ እንዲመለከቱ ዕድል የሚሰጥ ነው። ፈተና አይደለም። ጥያቄዎቹ ትክክለኛ የሚባል መልስ የሌላቸው ሲሆን የተለያዩ ሰዎች የተለያዩ መልሶች ሊኖሯቸው ይችላሉ። መልሶችዎ ስለራስዎ በትክክል የሚሰማዎትን ነገር ማሳየታቸውን እርግጠኛ ይሁኑ። እባክዎን ስለመልሶችዎ ከማንኛውም ሰው ጋር አይነጋገሩ። እኛም የእርስዎን ምላሾች ለማንም ሰው አሳልፈን አንሰጥም።

ለመጀመር ዝግጁ ሲሆኑ እባክዎን እያንዳንዱን አረፍተ ነገር በጥሞና በማንበብና በማዳመጥ መልስዎን ይወስኑ (እኔ ድምጹን ከፍ አድርጌ ሳነብ እርስዎ ቀስ ብለው ለራስዎ በጥሞና ያዳምጡኝ)። ለእያንዳንዱ ጥያቄ አምስት ከወሰጣቸው አንዱን ሊመርጡ የሚገባ አማራጮች አሉ - “እውነት”፣ “ሀሰት” እና በመካከላቸው ያሉ ሶስት አማራጮች። ለእያንዳንዱ ምላሾች ከአንድ እስከ አምስት ያሉት ቁጥሮች ከእያንዳንዱ ዐረፍተ ነገር ቀጥለው ይገኛሉ። ምላሾቹ ከቁጥሮቹ በላይ በየገጹ አናት ላይ ይገኛሉ። ለአንድ ዐረፍተ ነገር ያለዎትን መልስ ይምረጡ እና የመረጡትን ትክክለኛ መልስዎ የሆነውን ቁጥር በግልጽ ይክበቡ። አንድ መልስ ብቻ ይምረጡ። መልስዎን ድምጽዎን ከፍ አድርገው በመናገር ወይም ስለሱ ከማንም ጋር በመነጋገር አይግለጹት።

እባክዎን ምንም ዓይነት ዐረፍተ ነገሮች ሳይመልሱ አይተው። እርግጠኛ ካልሆኑ እባክዎን ዕርዳታ ይጠይቁ።

እባክዎ ስለዕርስዎ ከሁሉም የበለጠ ትክክል የሆነውን ሀሳብ የያዘውን ቁጥር ይምረጡ።

ዐረፍተ ነገር	ሀሰት	ብዙ ጊዜ ሀሰት	አንዳንድ ጊዜ ሀሰት አንዳንድ ጊዜ እዉነት	ብዙዉን ጊዜ እዉነት	እዉነት
01. እኔ ቆንጆ ነኝ።	1	2	3	4	5
02. በሁሉም የትምህርት አይነቶች ጎበዝ ነኝ።	1	2	3	4	5
03. በፍጥነት መሮጥ እችላለሁ።	1	2	3	4	5
04. ትምህርት ቤት በንባብ ጥሩ ዉጤት አመጣለሁ።	1	2	3	4	5
05. ወላጆቼ ፍላጎቴን ይረዱልኛል።	1	2	3	4	5

ዐረፍተ ነገር	ሀሰት	ብዙ ጊዜ ሀሰት	አንዳንድ ጊዜ ሀሰት አንዳንድ ጊዜ እዉነት	ብዙዉን ጊዜ እዉነት	እዉነት
06. የሂሳብ ትምህርትን እጠላለሁ።	1	2	3	4	5
07. በርካታ ዳደሮች አለኝ።	1	2	3	4	5
08. ያለኝን መልክ እወደዋለሁ።	1	2	3	4	5
09. ሁሉንም የትምህርት አይነቶች ስማርና ሳጠና ደስ ይለኛል።	1	2	3	4	5
10. መሮጥና ጠንክሬ መጫወት ደስ ይለኛል።	1	2	3	4	5
-----					
11. ማንበብ እወዳለሁ።	1	2	3	4	5
12. ወላጆቼ በማደርገዉ ነገር ብዙ ጊዜ ደስተኞች አይደሉም።	1	2	3	4	5
13. በሂሳብ ትምህርት ዉስጥ የሚሰራ ስራ ለእኔ ቀላል ነዉ።	1	2	3	4	5
14. በቀላሉ ዳደሮች አፈራለሁ።	1	2	3	4	5
15. ደስ የሚል የፊት ገጽታ አለኝ።	1	2	3	4	5
-----					
16. በሁሉም የትምህርት አይነቶች ጥሩ ዉጤት አገኛለሁ።	1	2	3	4	5
17. ስፖርትና ጨዋታዎችን እጠላለሁ።	1	2	3	4	5
18. በማንበብ ጥሩ ችሎታ አለኝ።	1	2	3	4	5
19. ወላጆቼን እወዳቸዋለሁ።	1	2	3	4	5
20. ሂሳብ ትምህርትን በጉጉት እጠብቀዋለሁ።	1	2	3	4	5

21. ብዙዎቹ ልጆች እኔ ካለኝ የበለጠ ጓደኞች አሏቸው።.....1	2	3	4	5
22. እኔ ጥሩ መልክ ያለኝ ልጅ ነኝ።.....1	2	3	4	5
23. ሁሉንም የትምህርት አይነቶች እጠላቸዋለሁ።.....1	2	3	4	5
24. ስፖርትና ጨዋታዎች ያስደስቱኛል።.....1	2	3	4	5
25. የማንበብ ዝንባሌና ፍላጎት አለኝ።.....1	2	3	4	5

---

26. ወላጆቼ ይወዱኛል።.....1	2	3	4	5
27. በሂሳብ ትምህርት ጥሩ ዉጤት አገኛለሁ።.....1	2	3	4	5
28. ከልጆች ጋር በቀላሉ እግባባለሁ።.....1	2	3	4	5
29. በርካታ ጠቃሚ ነገሮችን እፈጽማለሁ።.....1	2	3	4	5
30. እኔ መልክ ጥፋ (አስቀያሚ) ነኝ።.....1	2	3	4	5

---

31. በሁሉም የትምህርት አይነቶች የምማራቸውንና የማጠናቸውን ነገሮች በቶሎ እረዳለሁ።	1	2	3	4	5
32. ጠንካራ ጠንቻዎች አሉኝ።.....1	2	3	4	5	
33. ንባብ ማንበብ አልችልም።.....1	2	3	4	5	
34. የራሴ ልጆች ቢኖሩኝ ልክ ወላጆቼ እንዳሳደጉኝ አድርጌ ላላድጋቸው እፈልጋለሁ።:1	2	3	4	5	
35. ለሂሳብ ትምህርት ዝንባሌና ፍላጎት አለኝ።.....1	2	3	4	5	

---

ዐረፍተ ነገር	ሀሰት	ብዙ ጊዜ ሀሰት	አንዳንድ ጊዜ ሀሰት አንዳንድ ጊዜ እዉነት	ብዙውን ጊዜ እዉነት	እዉነት
----------	-----	-----------	----------------------------	--------------	------

36. እኔን መወደድ ቀላል ነዉ /እኔ ለመወደድ ቀላል ነኝ/.....1	2	3	4	5
37. በአጠቃላይ እኔ ጥሩ አይደለሁም።.....1	2	3	4	5
38. ሌሎች ልጆች ቆንጆ እንደሆንኩ ያስባሉ።.....1	2	3	4	5
39. ለሁሉም የትምህርት አይነቶች ዝንባሌና ፍላጎት አለኝ።.....1	2	3	4	5
40. በስፖርት ጥሩ ነኝ።.....1	2	3	4	5

---

41. ንባብ ማንበብ ደስ ይለኛል።.....1	2	3	4	5
42. ወላጆቼና እና እኔ ብዙ ጊዜ አብረን እናሳልፋለን።.....1	2	3	4	5
43. የሂሳብ ትምህርትን ቶሎ የመረዳት ችሎታ አለኝ።.....1	2	3	4	5

44. ሌሎች ልጆች ዳደሮቻቸው እንድሆን ይፈልጋሉ።.....	1	2	3	4	5
45. በአጠቃላይ እኔ የሆንኩትንና ያለሁበትን ሁኔታ እወደዋለሁ።.....	1	2	3	4	5
46. የሚያምር ሰውነት አለኝ።.....	1	2	3	4	5
47. በሁሉም የትምህርት አይነቶች ሰነፍ ነኝ።.....	1	2	3	4	5
48. ምንም ሳላቆም ረጅም ርቀት መሮጥ እችላለሁ።.....	1	2	3	4	5
49. ማንበብ ለእኔ ቀላል ስራ ነው።.....	1	2	3	4	5
50. ወላጆቼ ለማነጋገር ይቀላሉ።.....	1	2	3	4	5

---

51. ሂሳብ ትምህርትን እወደዋለሁ።.....	1	2	3	4	5
52. ከአብዛኞቹ ሌሎች ልጆች የበለጠ ዳደሮች አሉኝ።.....	1	2	3	4	5
53. በአጠቃላይ የምኮራበት ብዙ ነገር አለኝ።.....	1	2	3	4	5
54. ከአብዛኞቹ ዳደሮቹ የበለጠ የሚያምር ሰውነት አለኝ።.....	1	2	3	4	5
55. ሁሉንም የትምህርት አይነቶች በጉጉት እጠብቃቸዋለሁ።.....	1	2	3	4	5

---

56. እኔ ጥሩ አትሌት /ስፖርተኛ/ ነኝ።.....	1	2	3	4	5
57. ንባብን በጉጉት እጠብቃለሁ።.....	1	2	3	4	5
58. ከወላጆቼ ጋር በደንብ እግባባለሁ።.....	1	2	3	4	5
59. በሂሳብ ትምህርት ጥሩ ነኝ።.....	1	2	3	4	5
60. በእኔ ዕድሜ ባሉ ልጆች ዘንድ በጣም እወደዳለሁ።.....	1	2	3	4	5

---

61. ምንም ነገር በትክክል መስራት አልችልም።.....	1	2	3	4	5
62. እንደ አፍንጫ፣ አይን እና ጸጉር ያሉ ጥሩ ጥሩ ገጽታዎች አሉኝ።.....	1	2	3	4	5
63. በሁሉም የትምህርት ዓይነቶች ውስጥ ያለ ስራ ለእኔ ቀላል ነው።.....	1	2	3	4	5
64. አንድን ኳስ ስወረወር ጎበዝ ነኝ።.....	1	2	3	4	5
65. ንባብ ማንበብ (ምንባብ) እጠላለሁ።.....	1	2	3	4	5

ዐረፍተ ነገር	ሀሰት	ብዙ ጊዜ ሀሰት	አንዳንድ ጊዜ ሀሰት አንዳንድ ጊዜ እወዛለሁ	ብዙውን ጊዜ እወዛለሁ	እወዛለሁ
----------	-----	-----------	-----------------------------	---------------	-------

66. ወላጆቼና እና እኔ አብረን በመሆን ብዙ ቀልዶችን እንቀላላለን።.....	1	2	3	4	5
67. አብዛኛው ሰው እንደሚያደርገው አድርጌ ነገሮችን ማከናወን እችላለሁ።.....	1	2	3	4	5

68. ሂሳብ መሰራት ያስደስተኛል።.....1	2	3	4	5
69. አብዛኞቹ ሌሎች ልጆች ይወዱኛል።.....1	2	3	4	5
70. ሌሎች ሰዎች ጥሩ ሰው እንደሆንኩ ያስባሉ።.....1	2	3	4	5
-----				
71. ሁሉንም የትምህርት አይነቶች እወዳቸዋለሁ።.....1	2	3	4	5
72. በርካታ እኔን የሚመለከቱ ነገሮች ጥሩ ናቸው።.....1	2	3	4	5
73. በማንበብ በርካታ ነገሮችን ቶሎ እረዳለሁ።.....1	2	3	4	5
74. እንደ አብዛኛው ሰው ሁሉ እኔም ጥሩ ነኝ።.....1	2	3	4	5
75. በሂሳብ ትምህርት ሰነፍ ነኝ።.....1	2	3	4	5
76. አንድ ነገር ሳከናወን በደንብ አድርጌ ነው።.....1	2	3	4	5
-----				

# Appendix 2

The questions that are used as point of discussion in the focus group discussions

1. Do you think children of 8 years as well as 12 years of age in this community comment about the attractiveness of their physical appearance and physical abilities? How do you think the younger and the older children rate themselves in this regard?

በእናንተ አካባቢ ዕድሜአቸው 8 እና 12 የሆኑ ልጆች ስለራሳቸው አካላዊ ውበትና ስለ አካላዊ እንቅስቃሴ ችሎታቸው አስተያየት ይሰጣሉ? በነዚህ ዕድሜዎች ላይ ያሉ ልጆች በዚህ ረገድ ራሳቸውን ሲመዘኑ ምን ልዩነት አላቸው ትላላችሁ?

2. Do you think children of 8 years as well as 12 years of age in this community comment about their relation with their parents and peers? How do you think the younger and the older children rate themselves in this regard?

በእናንተ አካባቢ ዕድሜአቸው 8 እና 12 የሆኑ ልጆች ከወላጆቻቸው ጋርና ከእኩዮቻቸው ጋር ስላላቸው ግንኙነት አስተያየት ይሰጣሉ? በነዚህ ዕድሜዎች ላይ ያሉ ልጆች በዚህ ረገድ ራሳቸውን ሲመዘኑ ምን ልዩነት አላቸው ትላላችሁ?

3. Do you think children of 8 years as well as 12 years of age in this community comment about their abilities or interest of reading, mathematics and school in general? How do you think the younger and the older children rate themselves in this regard?

በእናንተ አካባቢ ዕድሜአቸው 8 እና 12 የሆኑ ልጆች በንባብ፣ በሂሳብ እና በአጠቃላይ ለትምህርት ቤት ስላላቸው ዝንባሌና ችሎታ አስተያየት ይሰጣሉ? በነዚህ ዕድሜዎች ላይ ያሉ ልጆች በዚህ ረገድ ራሳቸውን ሲመዘኑ ምን ልዩነት አላቸው ትላላችሁ?

4. In your opinion do children of 8 years as well as 12 years of age in your area comment about themselves in general? How do you think the younger and the older children rate themselves in this regard?

በእናንተ አካባቢ ዕድሜአቸው 8 እና 12 የሆኑ ልጆች ስለአጠቃላይ ብቃታቸው አስተያየት ይሰጣሉ? በነዚህ ዕድሜዎች ላይ ያሉ ልጆች በዚህ ረገድ ራሳቸውን ሲመዘኑ ምን ልዩነት አላቸው ትላላችሁ?

### Appendic 3: List of participants in the study

No	Name of the participant	Gender	Age	Grade	School
	Getu Yeshitila	M	11	3	Daletina Mekegne
	Dalelu Alemu	F	12		Daletina Mekegne
	Yiderder Belay	F	8	2	Daletina Mekegne
	Simiwubita Belay	F	8	2	Daletina Mekegne
	Abebu Fantaye	F	8	2	Daletina Mekegne
	Aberaham Nigusie	M	9	2	Daletina Mekegne
	Girum Tilahun	M	8	2	Daletina Mekegne
	Dawit Getaneh	M	8	2	Daletina Mekegne
	Belihu Belayneh	M	8	2	Daletina Mekegne
	Tesfaye Fantaye	M	8	2	Daletina Mekegne
	Askale Mekasha	F	8	2	Angolela
	Lakech Mulugeta	F	8	2	Angolela
	Habtamu Bete	M	8	2	Angolela
	Hayelie Meskelie	M	8	2	Angolela
	Dinkalem Gebeyehu	M	8	2	Angolela
	Hailiye	M	8	2	Angolela
	Kidist	F	9	3	Angolela
	Genet Beza	F	8	3	Angolela
	Tekelmariam Kefelegne	M	9	3	Angolela
	Zerihun Demisie	M	9	3	Angolela

No	Name of the participant	Gender	Age	Grade	School
	Wubayehu Nigusie	F	8	3	Angolela
	Wondatir Dagne	M	8	3	Angolela
	Mestewat Mogesie	F	8	3	Angolela
	Beamelak Eshetu	M	8	2	Angolela
	Ayelech Mekonen	F	8	2	Angolela
	Adise Ayele	M	9	3	Angolela
	Zinu Zewudie	F	8	3	Angolela
	Bereket Mulatu	M	8	2	Angolela
	Tizibit Negusie	F	8	3	Angolela
	Atsedu Wondwosen	F	8	3	Angolela
	Dinkinesh Belihu	F	9	3	Angolela
	Ashenafi Abebe	M	9	3	Angolela
	Helen Wube	F	9	2	Angolela
	Wubit Workiye	F	8	3	Angolela
	Abebayehu Balcha	M	8	2	Angolela
	Zebene Abebe	M	9	2	Daletina Mekegne
	Adebebe Wubshet	F	9		
	G/tsadik Hayiliyie	M	12	2	Daletina Mekegne
	Alemimesh Tekelu	F	11	3	Daletina Mekegne
	Yirgalem	M	10	2	Daletina Mekegne
	Girum Tilahun	M	10	2	Daletina Mekegne

No	Name of the participant	Gender	Age	Grade	School
	Getachew Hailiye	M	12	3	Daletina Mekegne
	Fekadu Mamuye	M	10	3	Daletina Mekegne
	Amelework Getahun	F	10	3	Daletina Mekegne
	Beza Girma	F	9	3	Daletina Mekegne
	Desta Yetesha	M	9	3	Daletina Mekegne
	Awugichew Shewaye	M	11	3	Daletina Mekegne
	Mikere	M	10	2	Daletina Mekegne
	Asrate	M	10	2	Daletina Mekegne
	Woinshet Shenkute	F	10	3	Daletina Mekegne
	Yeshitila	M	9	2	Daletina Mekegne
	Desealegne Tsegaye	M	11	3	Daletina Mekegne
	Lemlem Tiruneh	F	10	3	Daletina Mekegne
	Hailemariam Negash	M	12	6	Angolela
	Birhane Zenebe	F	12	6	Angolela
	Meseret Asefa	F	10	3	Angolela
	Tekeletsadik Sidelele	M	11	4	Angolela
	Wolansa Bekele	F	10	3	Angolela

No	Name of the participant	Gender	Age	Grade	School
	Abera	M	8	2	Woinabadera
	Tigist Minaleshewa	F	11	3	Daletina Mekegne
	Workagegne Gebeyehu	M	11	3	Daletina Mekegne
	Asrate Firde	M	11	3	Daletina Mekegne
	Bizunesh Beyene	F	10	3	Daletina Mekegne
	Tilahun Gebeyehu	M	12	3	Daletina Mekegne
	Fiker Wondimineh	M	11	3	Daletina Mekegne
	Getnet Eshetu	M	11	2	Daletina Mekegne
	Getu Yeshigeta	M	11	3	Daletina Mekegne
	Felekech Debebe	F	11	4	Woinabedera
	Tilahun Dinku	M	10	4	Woinabedera
	Ayinalem Abani	F	10	4	Woinabedera
	Simerere Mengistu	M	11	4	Woinabedera
	Habetamu Dinku	M	12	4	Woinabedera
	Fikere Hailiyie	M	12	3	Woinabedera
	Tesfu Haile	F	10	4	Woinabedera
	Yemane Taye	M	12	4	Woinabedera
	Tadelech Zewdu	F	9	2	Woinabedera

No	Name of the participant	Gender	Age	Grade	School
	Etagegnehu Mulugeta	F	11	4	Woinabedera
	---	F	10	2	Daletinamekegne
	Bekelech Hailiyie	F	11	2	Daletinamekegne
	Tefera Tsegayie	M	10	3	Daletinamekegne
	Alemu Girma	M	11	2	Daletinamekegne
	Abraham Gezahegne	M	11	5	Angolela
	Kefelegne Endalik	M	11	3	Daletinamekegne
	Senayit Tsegaye	F	12	3	Daletinamekegne
	Abebech Chernet	F	11		Daletinamekegne
	Asegedu Mulugeta	F	10	3	Daletinamekegne
	Workalemahu Dibab	M	10		Daletinamekegne
	Tsige Aleme	F	11	3	Daletinamekegne
	Workinesh Zenebe	F	11	3	Daletinamekegne
	Etagegne Hailiyie	F	10	3	Daletinamekegne
	Bekelu Hailu	F	9	2	Woinabadera
	Tesfanesh Demesu	F	9	4	Woinabadera
	Hailu Derebie	M	12	2	Woinabadera
	Mitikie Negash	F	8	3	Woinabadera

No	Name of the participant	Gender	Age	Grade	School
	Getaneh Abebe	M	12	5	Angolela
	Yeshi Mekonen	F	12	5	Angolela
	Haileliule Negusie	M	12	6	Angolela
	Zelalem Megeiste	M	12	6	Angolela
	Befekade Tadesse	M	12	6	Angolela
	Mandefero Getahun	M	12	5	Angolela
	Akelile Abebe	M	12	5	Angolela
	Tekelu Yitafer	M	12	5	Angolela
	Wederie Beyene	F	12	5	Angolela
	Mintamir Niguse	F	12	5	Angolela
	Fekadu Bekele	M	12	5	Angolela
	Tsehay Muluneh	F	11	5	Angolela
	Amare Bietemariam	M	12	6	Angolela
	Hailiyie Abera	M	12	5	Angolela
	Kasahun Amane	M	12	6	Angolela
	Abayenesh Fantaye	F	12	6	Angolela
	Wondesen Yeshigeta	M	12	5	Angolela
	Dimeme Kefegne	F	12	5	Angolela
	Sisay Wubishet	M	12	5	Angolela

No	Name of the participant	Gender	Age	Grade	School
	Liyuwork Bogale	F	12	6	Angolela
	Tirfe Beziye	F	9	5	Angolela
	Demesu Mogese	M	12	6	Angolela
	Wubeshet Demesu	M	12	6	Angolela
	Wondemu Redagna	M	8	2	Angolela
	Feleku Balcha	F	12	6	Angolela
	Tewabech Sileshi	F	12	6	Angolela
	Abebe Asefa	M	12	5	Angolela
	Kalkidan Wondwosen	M	12	6	Angolela
	Alem Belehu	F	12	6	Angolela
	Mekuria Mulugeta	M	11	5	Angolela
	Abiye Wubishet	M	10	3	Angolela
	Kidist Abegaz	F	10	5	Angolela
	Tiringo Endeshaw	F	10	5	Angolela
	Tadesse Bekele	M	12	5	Angolela
	Birehanu Alemayehu	M	12	5	Angolela
	Gebresenbet Belachew	M	12	5	Angolela
	Jenbere Tekelie	F	11	5	Angolela

### **Declaration**

The thesis is my original work; it has not been presented for a degree in any other university and all sources of material used for the thesis have been duly acknowledged.

Melaku Zeleke

Signature\_\_\_\_\_

Date: June 2014