



**ADDIS ABABA UNIVERSITY**

**ADDIS ABABA INSTITUTE OF TECHNOLOGY**

**SCHOOL OF ELECTRICAL AND COMPUTER ENGINEERING**

**Railway Engineering Center**

---

**Performance Investigation of Addis Ababa Light Rail Transit**

**Communication Systems**

---

BY

Samuel Tamire Muluneh

A Thesis submitted to

The School of Electrical and Computer Engineering

Presented in Fulfillment of the Requirements for the Degree of Master of Science

(Electrical Engineering for Railway Systems)

Addis Ababa University

Addis Ababa, Ethiopia

July, 2017

**ADDIS ABABA UNIVERSITY**

**ADDIS ABABA INSTITUTE OF TECHNOLOGY**

**SCHOOL OF ELECTRICAL AND COMPUTER ENGINEERING**

**Railway Engineering Center**

This is to certify that the thesis prepared by Samuel Tamire, entitled: Performance Investigation of Addis Ababa Light Rail Communication Systems and submitted in partial fulfillment of the requirements for the degree of Master of Sciences (Electrical Engineering for Railway Systems) complies with the regulations of the University and meets the accepted standards with respect to originality and quality.

Signed by Examining Committee:

Examiner Yalemzewde N. (Dr.)      Signature \_\_\_\_\_      Date July,2017

Examiner Yihenew W. (Dr.)      Signature \_\_\_\_\_      Date July,2017

Advisor Mr. Jigsa Tesfaye (Msc)      Signature \_\_\_\_\_      Date July,2017

Advisor \_\_\_\_\_      Signature \_\_\_\_\_      Date \_\_\_\_\_

## Declaration

I certify that research work titled “Performance Investigation of Addis Ababa Light Rail Transit Communication Systems” is my own work. The work has not been presented elsewhere for assessment. Where material has been used from other sources it has been properly acknowledged and referred.

Samuel Tamire Muleneh

Name of student

\_\_\_\_\_  
Signature

Place Addis Ababa, Ethiopia

Date of Submission: July,2017 G.C.

This thesis has been submitted for examination with my approval as a university advisor.

Mr. Jigsa tesfaye

Advisor

\_\_\_\_\_  
Signature

## Abstract

Railway communication system is an essential part of the railway system. It is the back bone for the railway operation and management, to control and monitor the different subsystems of the railway system. Thus, the data communication services required for the signaling and interlocking system, for passenger information at station terminals, for Supervisory Control and Data Acquisition (SCADA) and telemetry data which are used for monitoring and management of other subsystems such as power should be safe, reliable, effective and efficient. Thus, there is no doubt taking performance investigation of the railway communication system. Because, capabilities and performance of the railway communication systems (subsystems) degrade the safety, reliability, effectiveness and efficiency, and also can affect the railway operation.

Assessing performance investigation in Addis Ababa Light Rail Transit (AALRT) communication system is necessary to determine whether or not there is a performance problem requiring action. There are performance problems occurred currently as observed in the AALRT communication system. Most of the performance problems occurred in the transmission system, such as communication failure alarm type 56%, service failure alarm type 8% and equipment failure alarm type 36%. These performance problems could affected the day to day activities of the AALRT such as unable to transmit quickly, accurately and reliably the information and/or data, unable to make emergency calls and fail to transport data for signal system; it makes the dispatcher of the control center unable to real-time monitor important areas like station platforms, important level crossing of line, substation and switch section of depot.

This thesis found out all the details or facts and accomplishment about the communication system of the Addis Ababa Light Rail Transit. It also identified, analyzed and studied the root causes for the performance problems; discussed their impact and effect on the system. It also proposed a frame work of KPI parameters for the performance investigation and effective maintenance of the AALRT communication system.

Key Words: Communication System, Key Performance Indices (KPI), AALRT, SCADA, communication failure alarm, service failure alarm, equipment failure alarm.

## **Acknowledgement**

First and foremost, I would like to praise God for giving me the strength and help from the start to the end of the research. This research has been compiled with the help of my advisor Mr. Jigsa Tesfaye. I, from the bottom of my heart would like to pass my special thanks to him. Grateful mention is made for those who had helped me with consulting my research especially Ato Kefyalew Biru and Ato Zelalem working in the Addis Ababa Light Rail Transit Kality branch as Signaling and Communication Engineer.

I thank the Ethiopian Railway Corporation (ERC) for sponsoring this graduate study.

## Table of Contents

Abstract .....	i
Acknowledgement .....	ii
List of Figures .....	vi
List of Table .....	viii
List of acronyms .....	ix
Chapter One .....	1
Introduction.....	1
1.1. General Background.....	1
1.2. Statement of the Problem .....	2
1.3. Objectives.....	3
1.3.1. General Objectives .....	3
1.3.2. Specific Objectives .....	3
1.4. Literature Review .....	4
1.5. Contribution .....	6
1.6. Methodology .....	6
1.7. Motivation .....	9
1.8. Outline of the Thesis .....	9
Chapter Two.....	11
Communication System of the AALRT .....	11
2.1. The Transmission System .....	11
2.1.1. System Function .....	11
2.1.2. System Scheme and Configuration.....	11
2.1.3. Synchronous Digital Hierarchy (SDH).....	12
2.1.4. Add-Drop Multiplexer (ADM).....	16
2.2. The Radio Communication System.....	17
2.2.1. System Functions.....	17
2.2.2. System Scheme and Configuration.....	18
2.3. The Video Monitoring System.....	19
2.3.1. System Function .....	19
2.3.2. System Schemes and Configuration .....	20

2.4. The Telephone Communication System .....	20
2.4.1. System Function .....	20
2.4.2. System Scheme and Configuration.....	21
2.5. Power Communication System .....	22
2.5.1. System Function .....	22
2.5.2. System Schemes and Function .....	22
2.5.3. System Interfaces.....	23
Chapter Three.....	25
Performance Problems of the AALRT Communication System .....	25
3.1. Performance Problems of the Transmission System.....	24
3.1.1. POWER_FAIL (Power Failure) .....	25
3.1.2. FAN_FAIL (Fan Failure) .....	26
3.1.3. APS_FAIL (Automatic Protection Switching Failure Indication) .....	27
3.1.4. ETH_LOSS ( Loss of Ethernet interface connection).....	31
3.1.5. IN_PWR_ABN (Input power abnormal).....	32
3.1.6. FCS_ERR (Frame Check Sequence Error) .....	35
3.1.7. NE Communication Break.....	38
3.1.8. COMMUN_FAIL (Inter-board Communication Fail) .....	39
3.1.9. PS (Protection Switching indication) .....	39
3.1.10. MS_APS (Multiplex Section Automatic Protection Switching).....	39
3.1.11. VCAT-LOM VC-4 (VC-4 virtual concatenation loss of multi-frame) .....	40
3.1.12. AU_AIS (Administrative Unit Alarm Indication Signal).....	40
3.1.13. APS_INDI (Automatic Protection switching Indication).....	41
3.1.14. R-LOS (Receive Loss of signal).....	42
3.1.15. EXT_SYNC_LOS (Loss of External Clock Source) .....	42
3.2. Other Performance Problems of AALRT Communication System .....	43
Chapter Four .....	44
Key Performance Index (KPI) Parameters .....	44
4.1. Proposed Key Performance Indicator (KPI) Parameters for the Transmission System....	44
4.1.1. Key Performance Index (KPI) Parameters for Power Failure .....	44
4.1.2. G.821 and G.826 Performance Analysis .....	47

---

4.1.3. Performance events of an SDH Service .....	50
4.2. Proposed Key Performance Indicator (KPI) Parameters for the Telephone Communication System of AALRT .....	52
4.3 Proposed Key Performance Indicator (KPI) Parameter for the Radio Communication System of AALRT .....	53
4.4. Proposed Key Performance Indicator (KPI) Parameters for the Video Monitoring System of AALRT .....	55
4.5. The Role of Proposed Key Performance Indicators (KPI) for AALRT Communication System Maintenance .....	56
Chapter Five.....	57
Results and Discussion .....	57
Chapter Six.....	65
Conclusion, Recommendation and Suggestion for Future Work .....	65
6.1. Conclusion.....	65
6.2. Recommendation and Suggestion for future work.....	66
References.....	68
Appendix A: Terms and Definition .....	71
Appendix B: SDH Error and Alarm Monitoring .....	73

## List of Figures

Figure 1.1: Overall Network of the Communication System of the AALRT.....	1
Figure 1.2: The Flow Chart of the Methodology Adopted for the Research.....	7
Figure 2.1: Schematic Diagram of Transmission System.....	11
Figure 2.2: Terminology used in SONET/SDH.....	13
Figure 2.3: An SDH STM-1 frame showing the section overhead and the administrative unit Group.....	14
Figure 2.4: An SDH STM-1 frame with three administrative unit level 3s (AU-3) carried in the AUG.....	14
Figure 2.5: An SDH AU-3 and a Virtual Container level 3 (VC-3).....	15
Figure 2.6: an Add Drop Multiplexer (ADM).....	16
Figure 2.7: Schematic Diagram of Radio Communication System.....	18
Figure 2.8: Schematic Diagram of Video Monitoring System.....	19
Figure 2.9: Schematic Diagram of Telephone System.....	20
Figure 2.10: UPS Composition.....	22
Figure 2.11: Interface of the power supply system to the communication subsystem.....	22
Figure 3.1: Fan unit of the OptiX OSN 3500 sub-rack.....	25
Figure 3.2: APS/ MSP, K1/K2 byte functions .....	26
Figure 3.3: Basic SDH processes.....	27
Figure 3.4: AIS and FERF at MS and higher order Levels.....	28
Figure 3.5: (a) Micro-bending; (b) Macro-bending.....	32

---

Figure 3.6: Macro-bending schematic diagram.....	32
Figure 3.7: Schematic representation of micro-bending.....	33
Figure 3.8: The structure of a typical single-mode fiber.....	33
Figure 5.1: Graph of AALRT transmission system performance problem.....	63
Figure 5.2: Graph of Major AALRT transmission system performance problems .....	63
Figure 5.3: Graph of Critical AALRT transmission system performance problems.....	64
Figure 5.4: Graph of failure alarm types of AALRT transmission system.....	64

## List of Table

Table 4.1: End-to-end Error Performance Objectives for a 27500 km International Digital HRP at or above the Primary Rate.....49

Table 5.1: Performance Problems of the AALRT Transmission System (2015-2016 G.C).....62

## List of acronyms

AALRT	Addis Ababa Light Rail Transit
ADM	Add-Drop Multiplexer
ANSI	American National Standards Institution
AU	Administrative Unit
AUG	Administrative Unit Group
BBE	Background Block Error
BBU	Building Base Band Unit
BER	Bit Error Rate
BIP	Bit Interleaved Parity
EB	Errored Block
ES	Errored Second
ETSI	European Telecommunication Standard Institute
FTTH	Fiber To The Home
FAW	Frame Alignment Word
FCS	Frame Check Sequence
FERF	Far End Receive Failure
GoS	Grade of Service
GFP	Generic Framing Procedure
ITU	International Telecommunication Union
KPI	Key Performance Index

---

LP_REI	Lower Order Path Remote Error Indication
LAPS	Link Access Procedure-SDH
MSTP	Multi-Service Transfer Platform
MSOH	Multiplex Section OverHead
MS_RDI	Multiplex Section Remote Defect Indication
MS_REI	Multiplex Section Remote Error Indication
NE	Network Element
PSTN	Public Switched Telephone Network
QoS	Quality of Service
RRU	Radio Remote Unit
RSOH	Regenerative Section OverHead
SDH	Synchronous Digital Hierarchy
SONET	Synchronous Optical Networking
STM	Synchronous Transport Module
SCC	System Control & Communication Unit
SD	Signal Degrade
SES	Severely Errored Second
TETRA	TErrestrial Trunked Radio
VOIP	Voice over Internet Protocol
VC	Virtual Container

# Chapter One

## Introduction

### 1.1. General Background

Railway communication system is essential to ensure safe operation of rail vehicles and support railway infrastructures using data communication between control entities. The Railway communication technologies that have a great role are radio communication system (wireless), telephone system, video monitoring system, microwave system, optical systems and passenger information system.

The communication technologies that are used in the AALRT are wired and wireless communication system [1]. The wired system is composed of the telephone system, video monitoring system (CCTV) and the wireless system comprise the radio communication system. The communication system of the project is also includes the subsystems of the transmission system and the communications power supply. The whole communication subsystems have the function of centralized monitoring and management, and can carry out real-time monitoring, fault location, system configuration and records keeping.

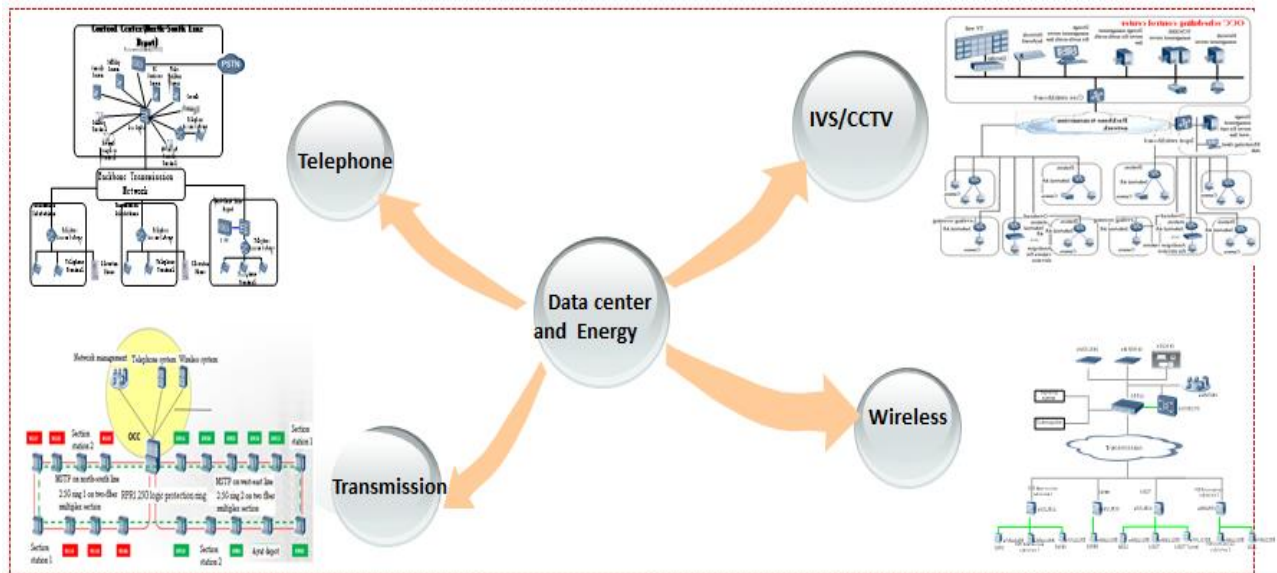

Figure 1.1: Overall Network of the Communication System of the AALRT [1].

No other mode of transport is more directly dependent on its communication technology than railways [1]. This is due to the basic nature of a railway system, which is characterized by two features. The first one is a distributed infrastructure which consists of many interrelated movable components which must be controlled and supervised. The second feature is the long braking distance of a rail vehicle, which often exceeds the driver visibility distance. Together, these two features create a railway system: many slow-braking trains sharing a complicated dynamic infrastructure. Operation of this complex system requires reliable and timely information about the train movements and the state of the infrastructure elements. Throughout the railway history, this exchange of information has been provided by various communication technologies [1].

Capabilities and performance of the railway communication systems affect railway operations. For instance, having faster information flow, train dispatching decisions can be made faster. By increasing communication reliability, the probability of travel delays due to communication failures is reduced. The more precise and detailed information available, the higher safety can be guaranteed [1].

Generally, there is no question and/or doubt taking performance investigation of railway communication system due to the fact that it is the back bone for reliable operation and management of the different activities of the railway system. This research paper identified and analyzed the root cause for the performance problem; it proposed KPI parameters for assessment in the AALRT communication system; introduced and suggested a set of KPI parameters for future performance investigation.

## **1.2. Statement of the Problem**

Assessing performance investigation in the communication system becomes fundamental due to the fact that performance problems have a major problem in the operation, management and different activities of the AALRT.

One of the root causes for the performance problem is when the power supply is failed to supply the high quality and reliable power for the communication subsystem equipment that is for the transmission system, telephone system, radio communication system and video monitoring system at the control center, the substation and the vehicle section. Thus, the communication

subsystem and components are unable to perform their desired task, function and operation. Furthermore, on the transmission system there are loss of network port connection (ETH loss), input power abnormal, frame check sequence error, external synchronization loss and loss of signal. Due to this, the communication subsystem equipment's were unable to transmit quickly, accurately and reliably the information and/or data that are needed for operation and management of all stations, depots substations and the control center of the project.

There was also a water leakage around Mexico square station that is NE (EW18) due to some construction problem. Then it burns out and damaged the installations of the distributed base station of the radio remote unit (RRU). As a result of this, the direct communication between the dispatcher and radio subscribers was interrupted, unable to make emergency calls and fail to transport data for signal system.

Considering the above performance problems of the AALRT communication system, it is paramount importance to study and analyze the root causes for performance problems, discussing their impact on the overall system.

## **1.3. Objectives**

### **1.3.1. General Objectives**

The main objective of this thesis is to investigate the performance of the Addis Ababa Light Rail Transit (AALRT) Communication system, through careful identification of the root causes of failure.

### **1.3.2. Specific Objectives**

- To identify potential bottlenecks that is employed in the existing AALRT communication system.
- To analyze and study performance problems
- To study the impact and effect on the system
- To introduce and propose a frame work of Key Performance Index (KPI) parameters that could be used to assess the performance of the communication system.
- Suggestion and comment based on the identifying root cause problems and KPI parameters.

## 1.4. Literature Review

There are many research papers done regarding to the performance of the different network devices and elements, on the communication technology that are used in transmitting data ,voice and video information based on the KPI parameters. Here, the work of international journals which focus on assessing the performance of wireless and mobile network communication (IJWMN) based on KPI indicators and/or parameters is presented. Performance analysis of different loss mechanisms in optical fiber communication system and gigabyte passive optical network KPI kit that provides features to display and analyze the various KPI associated with optical network terminal and optical line terminal is also presented.

Key Performance Indicators (KPIs) are widely used by Global System for Mobile Communication (GSM) and Universal Mobile Telecommunication System (UMTS) carriers with the aim of evaluating the network performance and the Quality of Service (QoS) delivered to users [2]. TERrestrial Trunked RAdio (TETRA) networks are basically designed to provide telecommunication services to Public Safety & Security (PSS) organizations, thus the compliance of the QoS levels required by these clients is usually critical. Despite that, the use of KPIs to assess the network performance and the QoS achieved in TERrestrial Trunked Radio (TETRA) systems is not very common [2]. It does not only states the need of monitoring and evaluating these parameters, but also introduces a set of KPIs which is considered necessary and sufficient in order to allow TETRA operators to be aware of whether provided services meet the QoS requirements established by end users. TETRA is a radio communication network, most parameters to quantify in these systems is similar to those applied to other radio access technologies designed primarily for the provision of voice services. For seek of performance investigation of the AALRT communication system some KPI parameter indicators are adopted to assess the performance problems of the radio communication system. One weak point of this work is that, the process of monitoring the indicators dose not lead to the knowledge of the compliance degree of the planned quality levels whether it is not followed by a process of assessment of these indicators. Thus, it must be established a set of target values for all proposed KPI parameters that can be evaluated during the analysis of QoS reports.

The delivering of both good quality of service (QoS) and Grade of Service (GoS) in any competitive mobile communication environment is a major factor to reducing subscribers' churn

rate [3]. Therefore, it is important for wireless mobile network operators to ensure stability and efficiency by delivering a consistent, reliable and high-quality end user (subscriber) satisfaction. This can only be achieved by conducting a regular network performance monitoring and optimization as it directly impacts the quality of the offered services and hence user satisfaction. It presents also, the results of network performance evaluation and optimization of a GSM network on cell cluster-basis, in Asaba region, South East Nigeria. It employs a combination of essential key performance indicators such as dropped call rate, call setup success rate and outage call rate to examine overall QoS and GoS performance of the GSM network [3]. From this result, the author observe that the network optimization showed significant performance improvement in terms of call drop rate, call set up success rate, and call block rate across. Thus, some performance parameters that could be helpful in analyzing, evaluating and determining the performance of the radio and telephone communication system of the AALRT have been taken.

Performance analysis of different loss mechanisms in optical fiber communication [4] deals with different loss mechanisms within the single mode fiber (SMF) in optical fiber communication. A number of mechanisms are responsible for the signal attenuation within optical fibers. As the optical signal propagates over long stretch of fiber, it becomes attenuated because of absorption, scattering, fiber bends by material impurities, and other effects. The transmission using high bandwidth can handle vast amounts of information, which can be further improved by reduction in fiber losses, increase in data rates and distances, and using appropriate operating wavelength in optical fiber communication. The recent developments in the area of fiber optic communication as well as the advances in different fiber types and their properties such as attenuation or loss and bandwidth are also discussed [4]. For the seek of this thesis the performance analysis of the proposed different loss in the fiber optic communication is taken.

Gigabyte passive optical network (GPON) is a point-to-multipoint [5], fiber to the premises network architecture in which unpowered optical splitters are used to enable a single optical fiber to serve multiple premises, typically 16-128. A GPON consists of an optical line terminal (OLT) at the Network Operation Center and a number of optical network units (ONUs) near end users. Performance of FTTH GPON network can be measured by using KPI of the OLT and the ONT of the network. Qubit GPON KPI kit provides features to display and analyze the various KPI associated with ONT and OLT. Thus KPI's associated with OLT and ONT which gives

performance specification about network elements are adopted for the AALRT optical communication system. Even though, the work of GPON does not explain about the threshold values of the KPI's associated with OLT and ONT which gives performance specification about the network elements.

The International Telecommunication Union (ITU-T) Telecommunication Standardization Sector of the G-series recommendation about the quality of digital links which is determined with the aid of bit error ratio tests (BERT), general aspects of digital transmission systems SDH performance monitoring for the network element view and end-to-end error performance parameters and objectives for international, constant bit-rate digital paths and connections is considered for this thesis work [6], [7], [8], [9], [10], [11].

## **1.5. Contribution**

Performance problems in the railway communication system of the AALRT have a major problem in the day to day activities of the railway system operation, management and different activities of the AALRT. This thesis tried and made an effort to identify those problems, analyzed and studied the root cause; discussed their impact and effect on the system lastly it proposed a framework of KPI parameters. After completing this, the communication system of the AALRT will become effective and maintenance of communication subsystem equipment's that is testing and inspection, maintaining, checking, repairing and adjusting the communication system (subsystem) will become as good or as effective as possible. It also fills the gap that there are no such performance investigation using KPI parameters has taken place since the AALRT has started its operation.

## **1.6. Methodology**

The research approach and methodology that could be used for the entire work to achieve the objectives are:

- Data collection about system function, system schemes and configuration, major technical standards, system interfaces of the entire communication subsystems.
- Reviewing related research paper works regarding to the performance analysis and investigation of the communication subsystem of the transmission system, telephone

system, radio communication system and video monitoring system that will be helpful throughout the research.

- Studying and find out all the details or facts and accomplishment about the communication system of the Addis Ababa Light Rail Transit (AALRT).
- Identifying and/or investigating a potential bottleneck that occurs in the communication system and/or subsystem.
- Analyzing and studying the root causes for the performance problems.
- Discussing the impact and effect on the system.
- Proposing a frame work of KPI parameters.
- Introducing and suggesting a set of KPI parameters that will be used to assess performance problems in the future.

The flow chart for the research methodology adopted in the research is shown below.

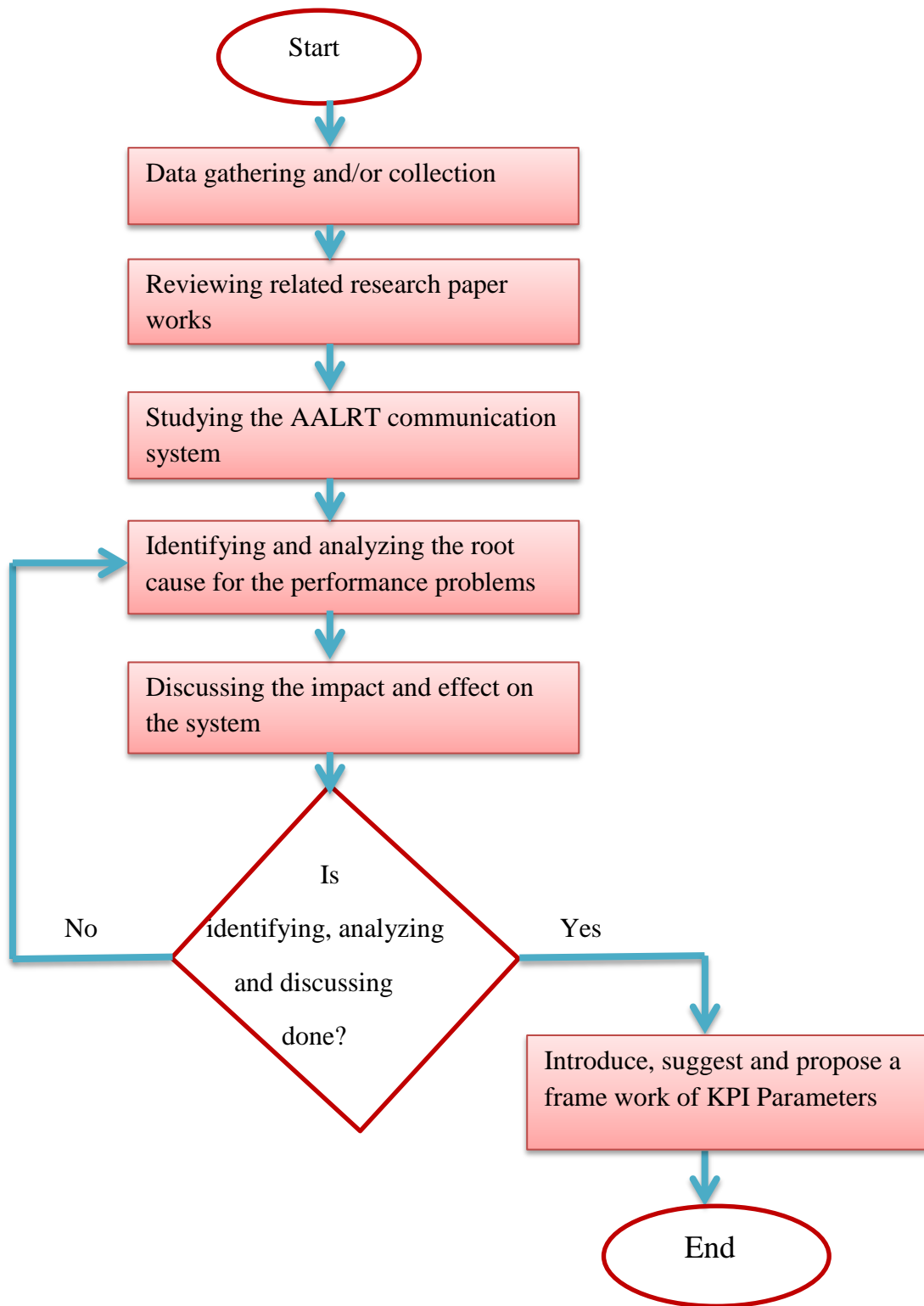

Figure 1.2: Flow Chart of the Methodology Adopted in the Research

## 1.7. Motivation

It is clear that a good and reliable communication system will be a basis for good, safe and reliable railway system. On the other hand, performance problems, limitation and failures of the communication system and/or subsystem will become limitation and failure of the whole railway system.

Due to the fact that there is a performance problem is occurred in the communication system of the AALRT. These are communication failure alarm 56%, service failure alarm type 8% and equipment failure alarm 36%. These performance problems could affected the day to day activities of the AALRT such as unable to transmit quickly, accurately and reliably the information and/or data, unable to make emergency calls and fail to transport data for signal systems. The author encouraged to identify those root causes for the performance problems and their impact and effect on the system in order to have a clear picture of the failures and for effective maintenance.

There is also no such performance investigation of communication system has taken place using KPI parameters since the Addis Ababa Light Rail Transit (AALRT) start its operation; so that this thesis will fill this gap. And also as a research thesis title in railway electrical engineering department from the previous graduate students. So that the author convinced to invest his academic resources on this research. If successful, that can contribute to the railway corporation, especially for the LRT to assure that its communication system and maintenance system will become effective.

## 1.8. Outline of the Thesis

This thesis paper organized into five chapters:

Chapter one presents an introduction part which constitutes the general background, statement of the problem, general and specific objectives, literature review, methodology, contribution and motivation of the research are included.

Chapter two describes about the communication system of the AALRT that is the transmission system, the radio communication system, the video monitoring system and the telephone system.

And also it explains the system function, system schemes and configuration with an appropriate diagram.

Chapter three investigates the performance problems of the AALRT communication system that happens in the transmission system, radio communication system, video monitoring system and telephone communication system. It also identifies and analyzes the root cause for the performance problem, their impact and effect on the system.

Chapter four proposes a frame work of KPI parameters for assessing performance investigation and for effective maintenance of the AALRT communication system

Chapter five deals with the result obtained from the performance problems and investigation, impact on the system of chapter three. It also presents the failures in tabular form and graphically.

Chapter six this is the final chapter, which includes conclusion, recommendations and suggestions for improvements and future works.

## Chapter Two

### Communication System of the AALRT

This chapter will present all the details or facts and accomplishment of about the communication system of the Addis Ababa Light Rail Transit.

The communication system of the AALRT is composed of the following subsystems: transmission, telephone, radio communications, video monitoring and communication power supply system. All communication subsystems have the function of centralized monitoring and management, and can carry out real-time monitoring, fault location, system configuration and records keeping [12].

#### 2.1. The Transmission System

##### 2.1.1. System Function

As a transmission bearing platform of the Project, function of the transmission system is to transmit quickly, accurately and reliably the information such as voice, data and image that is needed for operation and management of all stations, depots, substations and the control center of the Project. The information includes: Telephone information, Radio communication information, Monitoring information of the substation, Video monitoring image information, Monitoring information of each communication subsystem, other information on operation and management [12].

##### 2.1.2. System Scheme and Configuration

In accordance with the type of services and the bandwidth estimate, transmission system of the Project is constructed using multi-service transfer platform (MSTP) equipment based on synchronous digital hierarchy (SDH) whose transmission capacity is designed based on synchronous transport module (STM-16). ADM equipment is set for transmission system at all mixed traction and step-down substations (including mixed traction and step-down substation at sections), depots and the control center. Two-core optical fiber in the optical cable laid at both sides of the lines is used to form an E-W transmission loop and a N-S transmission loop, which are tangent to each other at the control center to form the transmission system. The transmission

system is protected by the protection ring at the two-fiber bidirectional multiplexing section. Schematic diagram of system composition is shown in figure 2.1:

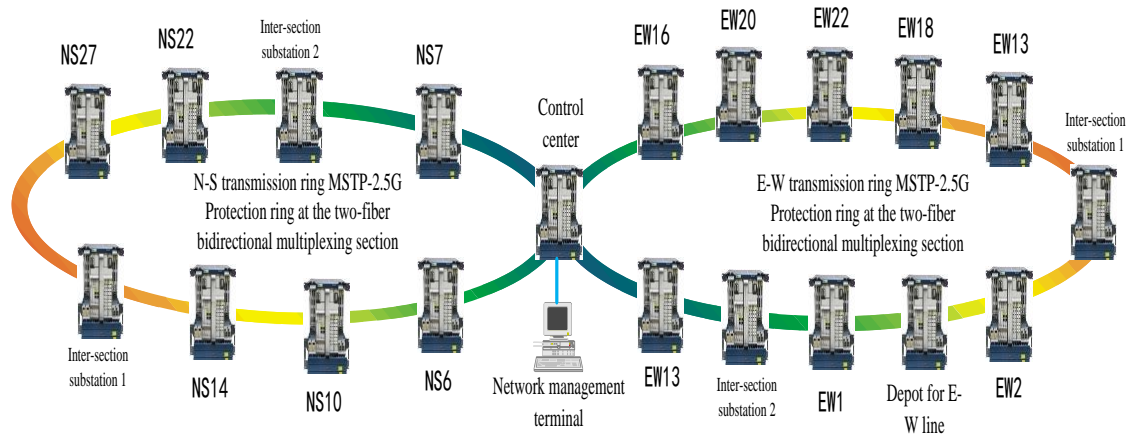

Figure 2-1 Schematic Diagram of Transmission System [12]

### 2.1.3. Synchronous Digital Hierarchy (SDH)

When data is transmitted over a communications medium, a number of things must be provided on the link, including framing of the data, error checking, and the ability to manage the link (to name a few). For optical communications these functions have been standardized by the ANSI T1X1.5 committee as SONET and by the ITU as SDH [13]. SDH and SONET refer to a group of fiber optic transmission rates that can transport digital signals with different capacities [14].

Since the AALRT transmission communication system is constructed using MSTP equipment based on SDH (the ITU standardized) for its optical transmission communication system whose transmission capacity is designed based on STM-16[12].

#### 2.1.3.1. SDH Standards

The new standard appeared first as SONET, drafted by the Bellcore in the United States, and then went through revisions before it emerged in a new form compatible with the international SDH. Both SDH and SONET emerged between 1988 and 1992[13].

SONET is an ANSI standard; it can carry as payloads the North American PDH hierarchy of bit rates: 1.5/6/45 Mbps, plus 2 Mbps (Known in the United States as E-1). SDH embraces most of SONET and is an international standard, but it is often regarded as a European standard because

its suppliers with one or two exceptions-carry only the ETSI defined European PDH bit rates of 2/34/140 Mbps(8 Mbps is omitted from SDH). Both ETSI and ANSI have defined, detailed SDH/SONET feature options for use within their geographical spheres of influence [13].

The original SDH standard defined the transport of 1.5/2/6/34/45/140 Mbps within a transmission rate of 155.52 Mbps and is being developed to carry other types of traffic, such as Asynchronous Transfer Mode (ATM) and Internet protocol (IP), within rates that are integer multiples of 155.52 Mbps. The basic unit of transmission in SONET is at 51.84 Mbps, but in order to carry 140 Mbps, the ITU established a base rate close to 150 Mbps for SDH [13]. Specifically, the rate the ITU established is three times the SONET STS-1 rate (three times 51.84 Mbps or 155.52 Mbps) and is called the Synchronous Transport Module – Level 1 (STM-1) signal. SDH also uses a 9 row frame but an STM-1 signal has three times as many columns as the STS-1 signal (270 octets instead of 90 octets). This pattern repeats for higher level of SONET/SDH – an STS-12 signal has 9 rows but 1,080 columns (12 times 90 columns), etc.

The overhead grows in the same proportion. In an STS-1 signal we have three columns of transport overhead. An STS-3/STM-1 signal has 9 columns of transport overhead. An STS-12/STM-4 signal has 36 columns of transport overhead. And an STS-768/STM-256 signal has a whopping 2,304 columns of transport overhead [13].

Since, the AALRT transmission system uses a capacity of STM-16 [12].These means that it has a line rate of 2,488.32 Mbps, a synchronous payload envelope rate of 2,405.376 Mbps and a transport overhead rate (that is overhead associated with the transport overhead columns only) of 84.672 Mbps with 144 columns of transport overhead.

### **2.1.3.2. Terminology used in SDH**

The end-to-end connection through a SDH network is always called the “path.” The connection between major nodes, such as between add/drop multiplexers is called a “line.” And the link between an add-drop multiplexer and a regenerator, or between two regenerators, is called a “section” [13]. See Figure 2.2 which shows this graphically.

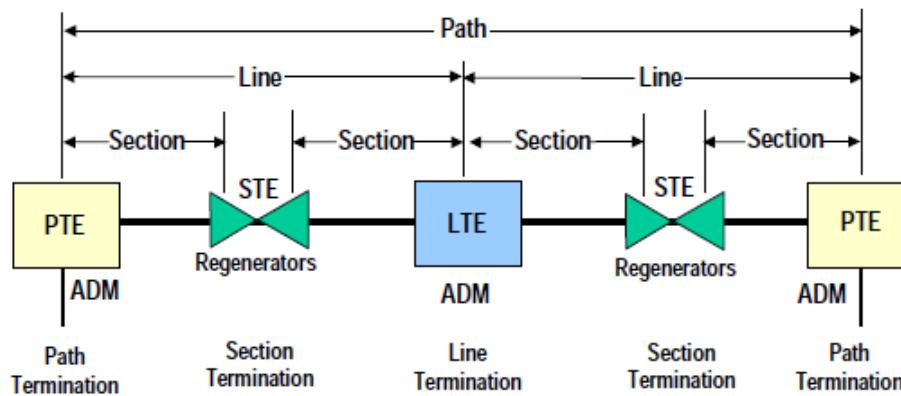

PTE = Path Terminating Equipment

LTE = Line terminating Equipment

STE = Section Terminating Equipment

Figure 2.2: Terminology used in SONET/SDH [13].

### 2.1.3.3. The Basic SDH STM-1 Frame Structure

Since SDH is three times the base rate of SONET. SDH has to do the same things as SONET but it must fit into a frame that's three times the size of the lowest level SONET frame. The basic STM-1 SDH frame is 270 columns by 9 rows, three times the size of the SONET STS-1 frame. This frame has nine columns of overhead, called Section Over Head (SOH). This is almost the same as the transport overhead in SONET, except that row four is excluded from the section overhead. So the section overhead is the first nine columns, less row four (as shown in Figure 2.3). The first three rows of the SOH are known as the Regenerator Section Over Head (RSOH), while the last five rows of the SOH are known as the Multiplex Section Over Head (MSOH).

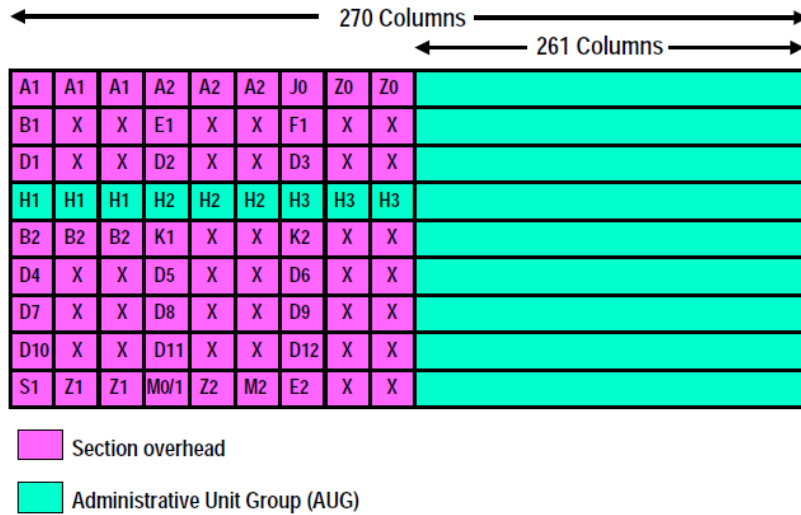

Figure 2.3: An SDH STM-1 Frame Showing the Section Overhead and the Administrative Unit Group [13].

The remaining 261 columns, plus row four of the first nine columns, is known as the Administrative Unit Group (or AUG). An AUG can consist of three Administrative Units, known as Administrative Unit level 3 (AU-3), or one Administrative Unit level 4 (AU-4). An AU-3 consists of 87 columns, plus three octets of pointers. An AU-4 consists of 261 columns, plus 12 octets of pointers.

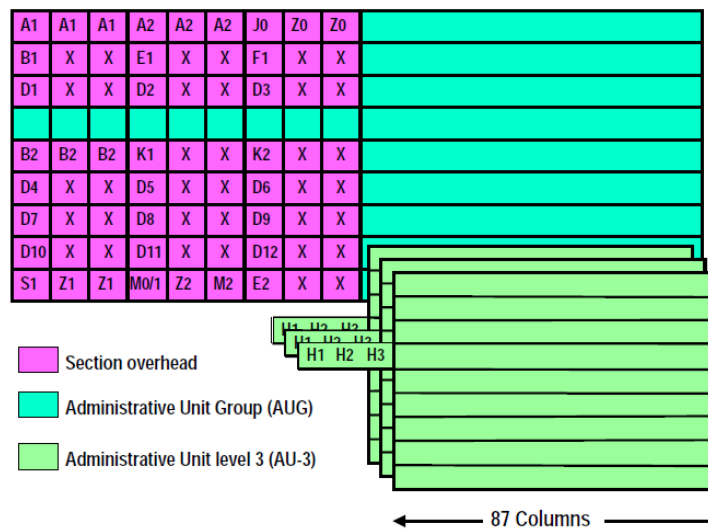

Figure 2.4: An SDH STM-1 Frame with Three Administrative Unit Level 3s (AU-3) Carried in the AUG [13].

An AU-3 is a fixed logical structure of 87 columns plus three octets of pointers – the AU-3 does not “float.” To provide the ability for the payload to float, SDH introduces the concept of a Virtual Container (VC). A virtual container which fits into an AU-3 is called a VC-3. And just like a SONET STS-1 payload, the VC-3 has one column of payload overhead (POH) and its mapping into an AU-3 includes two fixed stuff columns at columns 30 and 59. However, the VC-3 does not include the fixed stuff columns at columns 30 and 59, so the VC-3 is 85 columns with one column of POH at the beginning. When the VC-3 is mapped into an AU-3, columns 30 and 59 are skipped.

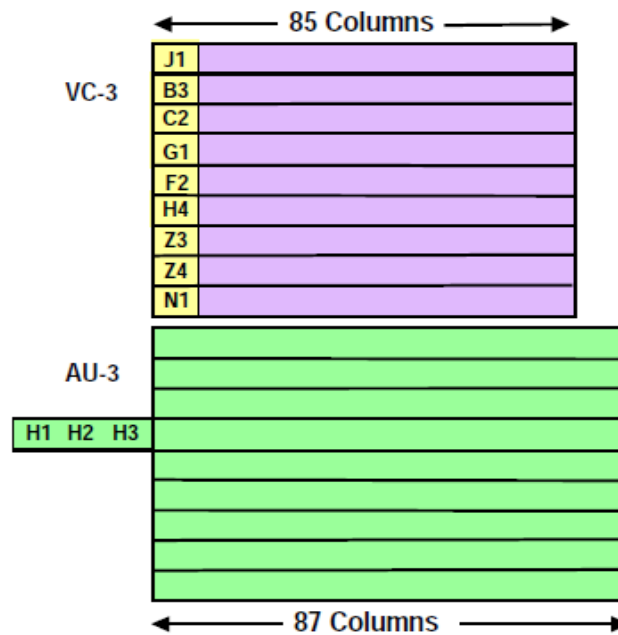

Figure 2.5: An SDH AU-3 and a Virtual Container level 3 (VC-3) which floats within the AU-3. Note that the VC-3 only has 85 columns while the AU-3 has 87. Two columns (30 and 59) are fixed stuff (same as in SONET) but are not included in the VC-3. When the VC-3 is mapped into the AU-3, these columns are skipped [13].

#### 2.1.4. Add-Drop Multiplexer (ADM)

An ADM is an important element of an optical fiber network. A multiplexer combines, or multiplexes, several lower-bandwidth streams of data into a single beam of light. An ADM also has the capability to add one or more lower-bandwidth signals to an existing high-bandwidth data streams, and at the same time can extract or drop other low-bandwidth signals, removing

them from the stream and redirecting the to some other network path. This is used as a local “on-ramp” and “off-ramp” to the high-speed network.

ADMs can be used both in long-haul core networks and in shorter-distance “metro” networks, although the former are much more expensive due to the difficulty of scaling the technology to the high data rates and dense wavelength division multiplexing (DWDM) used for long-haul communications. The main optical filtering technology used in ADM is the Fabry-Pérot etalon [15]. In optics, a Fabry–Pérot interferometer or etalon is typically made of a transparent plate with two reflecting surfaces, or two parallel highly reflecting mirrors.



Figure 2.6: Add-Drop Multiplexer [15]

Precisely, the former is an etalon and the latter is an interferometer, but the terminology is often used inconsistently. Its transmission spectrum as a function of wavelength exhibits peaks of large transmission corresponding to resonances of the etalon. It is named after Charles Fabry and Alfred Perot, who developed the instrument in 1899. Etalon is from the French *étalon*, meaning "measuring gauge" or "standard" [15].

Etalons are widely used in telecommunications, lasers and spectroscopy to control and measure the wavelengths of light. Recent advances in fabrication technique allow the creation of very precise tunable Fabry–Pérot interferometers [15].

## 2.2. The Radio Communication System

### 2.2.1. System Functions

Radio communication system is an important supporting measure to ensure traffic safety, to increase transportation efficiency and management level and to improve service quality [12]. This system provides radio communication services for all the related users in the control center

and the depot, including dispatcher, driver and staff, operating personnel, site personnel, etc. The radio communication system has the following functions:

- Dispatchers and radio subscribers can communicate directly, and there are selective calling, group calling, general calling and broadcast in response to business contact of different subscribers.
- Record and search the call conversations of dispatchers.
- Emergency call (insert) function.
- System network management (saving and monitoring) function.
- Data transmission function and can transport data for signal system

### 2.2.2. System Scheme and Configuration

The Radiio communication system of the AALRT meet the requirement of voice and data transmission functions that is digital communication system is considered [12]. Average flow of signal system data information transported by the vehicle radio set is about 50 Kbps; both the uplink flow and the downlink flow produced by each route of voice business are 4.75 Kbps. Depot communications traffic 41 trains and 80 portable radios are configured in the Project. There are 21 trains and 20 portable radios in the depot, so the maximum flow Communications traffic of main track Eight main tracks cover the districts and there are about 6 trains and 10 portable radios in each district [12].

The system composition of the radio communications system consists of system equipment and wireless coverage equipment, and system equipment include central switching control equipment, onboard radio set, portable radios, network management terminal, base station, etc. Wireless coverage equipment include outdoor directional antenna, Omni-directional antenna, outdoor antenna iron tower (derrick), directional antenna in tunnels, power divider, coupler, radio-frequency cable, etc [12].

The base station is installed in the inter-section substations and depots, which mainly include trans-receiver, control equipment, power supply unit, interface, etc. Distributed base stations are adopted which consists of BBU and RRU, and BBU installed with frame-type is set up in equipment room while RRU installed with wall-hanging type is set up in equipment room or proper locations outdoors in accordance with the actual conditions. BBU and RRU are connected

by optical fiber and power supply of RRU is provided by nearest equipment room. Lightning protection equipment must be installed in base stations having connection to on-ground antennas or cables [12].

The vehicle radio set (including host machine of station, antenna, control box, power supply unit, installation frame, etc.) is set up in the driver’s cab at both ends of the train, and the low-profile disk antenna is installed on top of the train [12].

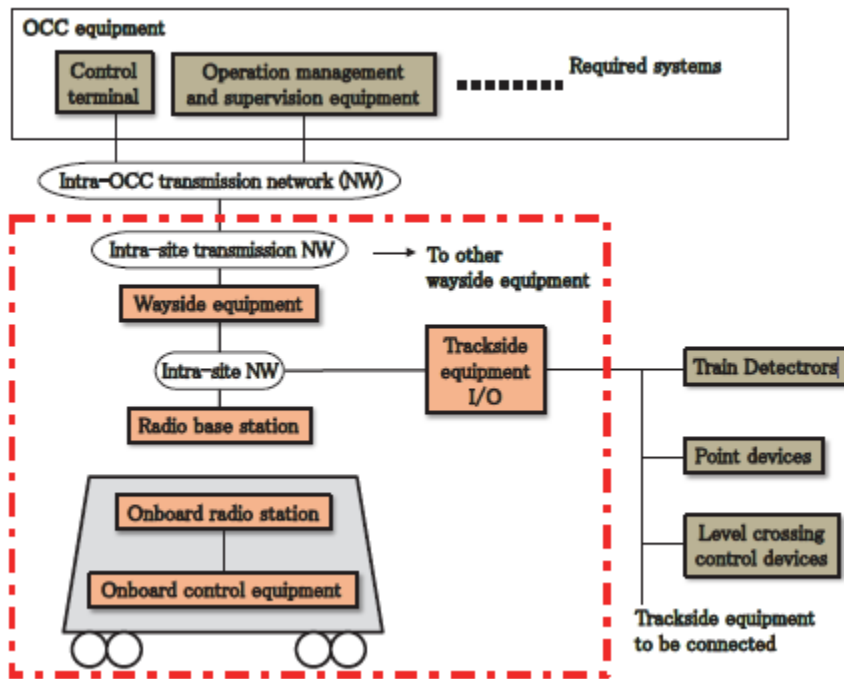

Figure 2.7: Schematic Diagram of Radio Communication System [12]

## 2.3. The Video Monitoring System

### 2.3.1. System Function

Video monitoring system is the supporting equipment for modernization of light rail operation and management. It is used by dispatching management personnel of control and command center for real time monitoring of passenger flow of station and situations of entering and departing station and important level crossing of lines to improve organization and management efficiency of operation and to ensure safe transportation of passengers on schedule by train [12].

### 2.3.2. System Schemes and Configuration

In accordance with the characteristics of the Project, one video monitoring center is installed in the whole line which is located at the building of the control center. Dispatcher of the control center can real-time monitor important areas like station platforms on the whole line, important level crossing of line, substation, switch section of depot [12]. The system is composed by cameras at front part of the site, transmission network; monitoring center equipment (including monitoring terminal, storage and management serve, etc). Schematic diagram of system composition is shown in Figure 2.8 below.

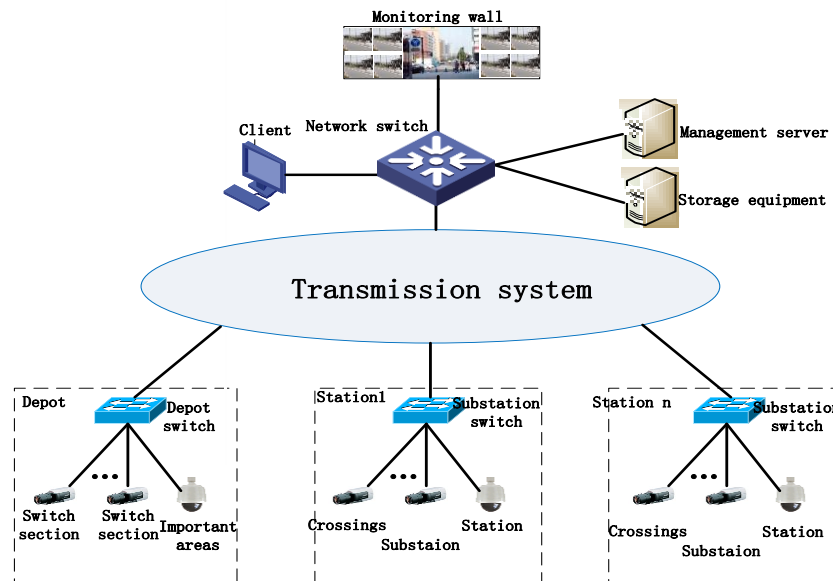

Figure 2.8: Schematic Diagram of Video Monitoring System [12]

## 2.4. The Telephone Communication System

### 2.4.1. System Function

Telephone system consists of telephone business and non-telephone business, and it provides business contact between management department, operating department and maintenance department and can interconnect with local public telephone network [12].

### 2.4.2. System Scheme and Configuration

Considering the distribution characteristics of telephone users of the Project, one set of telephone switchboard is installed in the control center and the depot of E-W line for each where the largest number of telephone users are located; one set of telephone access gateway equipment is installed in each substation where there're fewer telephone users, and the equipment connect the telephone users to the telephone switchboard in the control room via Ethernet channel provided by the transmission system in the method of VOIP [12].

In order to meet the telephone traffic requirements between internal telephone users, and between internal telephone users and public telephone users, the telephone switchboards in the control room and the depot of E-W line are connected with Ethernet channels; the telephone switchboard of the control room reserves two E1 digital junctions are reserved at telephone switchboard of the control center to connect with the district telephone bureau near the telecom operator so as to realize communication with the public switched telephone network. The interface is located at the equipment exterior line side of communications equipment room of the control center and expense for connecting to the PSTN is not included in the Project. Schematic diagram of system composition is shown in Figure 2.9 below:

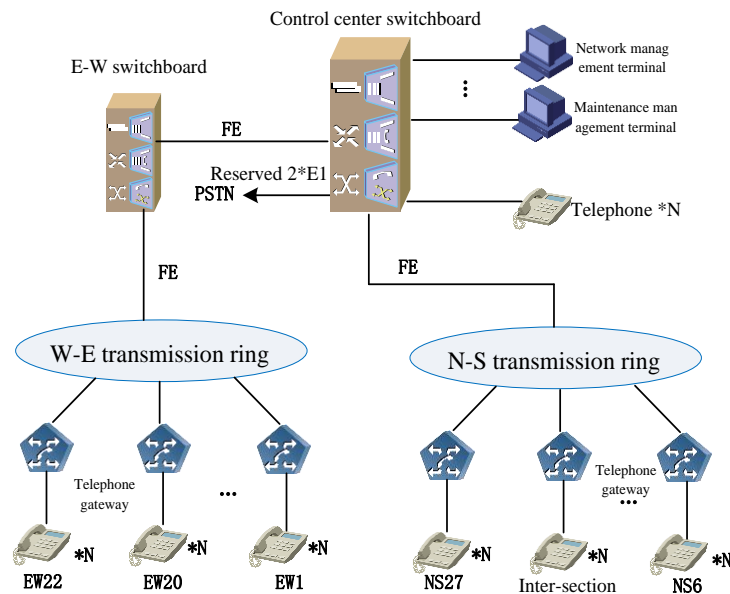

Figure 2.9: Schematic Diagram of Telephone System [12]

## 2.5. Power Communication System

### 2.5.1. System Function

Power supply system is one of the important parts of Ethiopia light rail communication system and its main function is to supply the high quality and reliable power for the communication system equipment at the control center, the substation and the vehicle section. The system shall have the following functions [12]:

- When the AC power source is normal, the communication power source shall supply the stable, reliable and uninterruptible power to each system;
- When the mains supply is broken down, it shall ensure that the system can conduct the uninterruptible working for some time and the period of standby power of the project shall be not less than 2 hours;
- The power supply equipment has the bypass function itself. When the rectification and inverter unit of the power equipment is broken down, the manual/automatic bypass can be realized and the direct power supply can be realized through outer power source (220/380).
- The power supply equipment itself has the output short-circuit protection function. In case of overload at the loading end (short circuit), the power supply equipment can switch to the bypass for power supply.
- The power system can realize the local and remote monitoring and in case of failure, timely warning can be provided;
- The management system of the power source can provide failure management, performance management, configuration management, safety management, etc

### 2.5.2. System Schemes and Function

According to the subsystem equipment configuration of the project, the power system shall provide 220V AC power supply. Thus, UPS power supply equipment shall be provided at the control center, the vehicle section and the substation of the system. It is mainly composed of UPS host, battery set, engineering cable, distribution box, etc. Schematic diagram of system composition is as follows [12]:

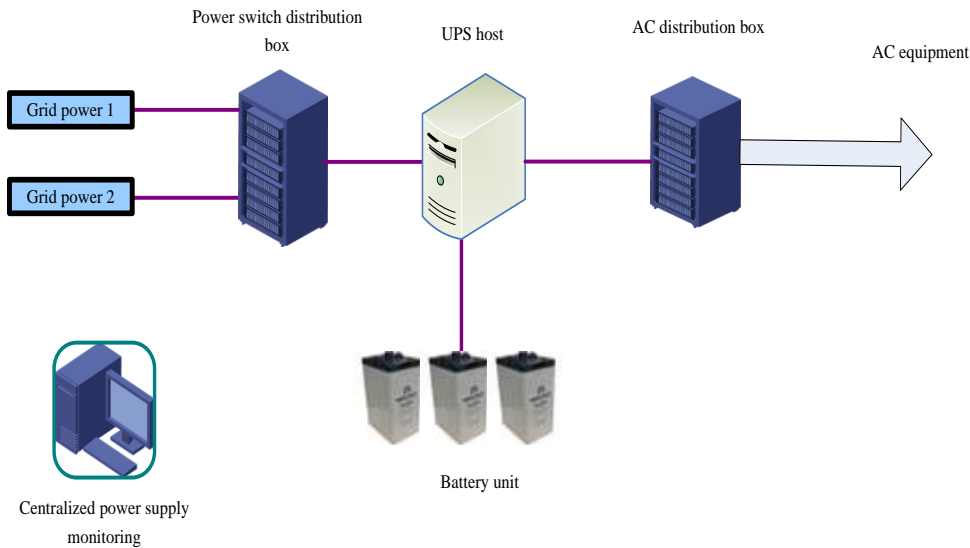

Figure 2.10: UPS Composition [12]

- ❖ UPS host: when the power source input is normal, the power can be supplied for the load by inverter; besides, the charger charges the battery; when the power source input is abnormal, the AC power supply can be realized through battery inversion;
- ❖ Battery: standby power, in case of abnormal AC power, the AC power supply for the equipment can be realized through inversion;
- ❖ Charger: while UPS is working, the charging of battery is completed;
- ❖ Distribution box (screen): provide UPS input and output bypass as well as maintenance bypass function.

### 2.5.3. System Interfaces

The system has the following interfaces [12].

- 1) Interface with transmission, telephone, CCTV and radio communication systems.

The power system supplies power for the equipment of the above-mentioned communication subsystem and the boundary is located at the distribution box of each subsystem equipment cabinet in the communication equipment room.

## 2) Interface with power supply systems.

The power system provides two-circuit individual 220V/380V power leads as the input of UPS system in each communication machine room.

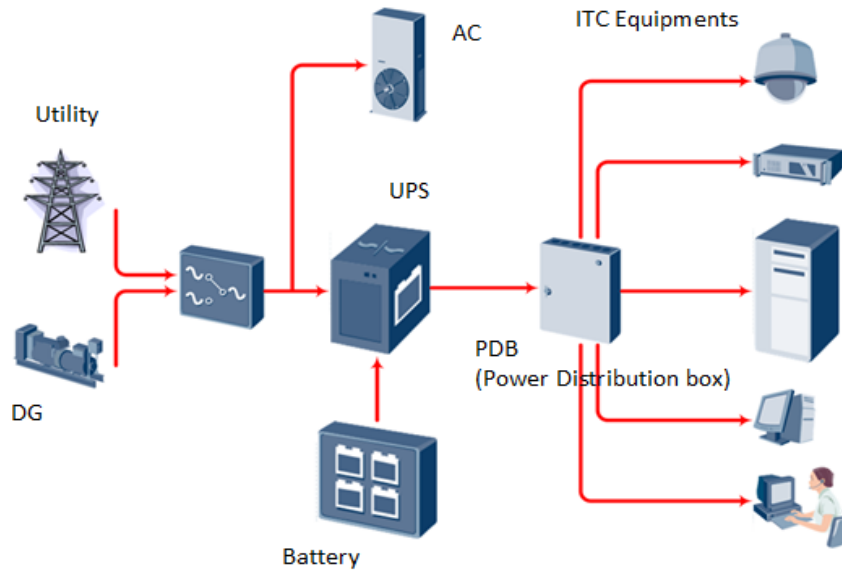

Figure 2.11 Interface of the Power Supply System to the Communication Subsystem [12].

## Chapter Three

### Performance Problems of the AALRT Communication System

This section presents the performance problems of the AALRT communication system that happens in the transmission system, radio communication system, video monitoring system and telephone communication system. It also identifies and analyzes the root cause for the performance problem, their impact on the system and their effect in the operation and management of the day to day activities of the AALRT.

#### 3.1. Performance Problems of the Transmission Systems

The basic building block of any communications facility is the transmission system (the channel). A major problem in communication facility is transmission impairments. The most significant impairments are attenuation, attenuation distortion, delay distortion and the various types of noise such as: thermal noise intermodulation noise, cross talk and impulse noise [16].

On the AALRT transmission system and/or medium there are faults which affects to transmit quickly, accurately and reliably the information and/or data that are needed for operation and management of all stations, depots substations and the control center of the project such as: the loss of network port connection (ETH loss), input power abnormality, frame check sequence error, external synchronization loss and loss of signal. The detail performance problem explanation is discussed in the preceding sections.

##### 3.1.1. POWER\_FAIL (Power Failure)

The POWER\_FAIL is an alarm indicating that the status of the power supply on the System Control & Communication Unit (SCC) is abnormal (for example, the battery on the SCC has no charge). It's a major severity and an equipment alarm type [17].

The possible root causes for the failure of the communication power supply are [18]: the standby power is off and the power board is failed.

Of the total failure of the transmission system the power is failed five times (or 2%). This failure can affect to supply stable, reliable and uninterruptible power to each communication system

(subsystem). When the standby power is off it cannot ensure that the system can conduct uninterrupted working for some time and period of the standby power of the project is less than two hours. It has also an impact on the system such as the system time is lost if the system is powered off.

### 3.1.2. FAN\_FAIL (Fan Failure)

The FAN\_FAIL is an alarm indicating the fan faults. This alarm is reported when the fan is faulty. It's a major severity and equipment alarm type [17].

The possible root causes for the fan failure are [18]:

- Fan is not switched on;
- The fan fails;
- The board and the back plane are poorly connected; and
- The speed level of fan is stop.

Of the total failure the fan fails thirty six times (14%). This affects the air flow, cooling and dissipation of the heat generated by the equipment. And also the operating system at efficient levels increases the risk of sudden equipment failure. It may be damaged the NE due to overheat; this would result in an interruption on the entire equipment services.

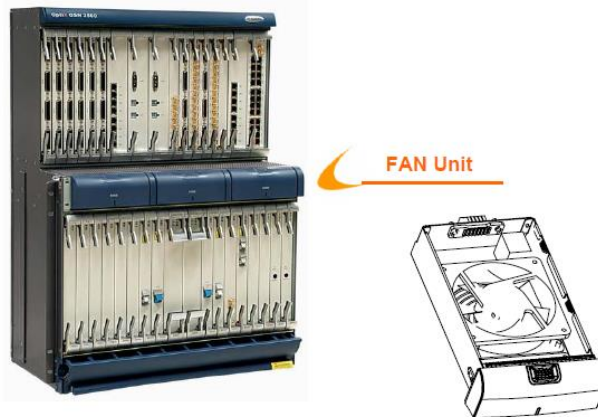

Figure 3.1: Fan unit of the OptiX OSN 3500 Intelligent Optical Transmission System [19].

### 3.1.3. APS\_FAIL (Automatic Protection Switching Failure Indication)

APS\_FAIL is an indication alarm APS protection switching failure. This alarm occurs when the MSP switching fails. It's a major severity and communication alarm type [17].

The simplest class of the mechanism for network survivability in the event of failure on a network element or link is automatic protection switching (APS). APS schemes involve reserving a protection channel (dedicated or shared) with the same capacity as the channel or facility to be protected. [20]

APS is the capability of a transmission system to detect a failure on a working facility and to switch to a standby facility to recover the traffic. This capability has a positive effect on the overall system availability [21].

Only the Multiplex Section in SDH is protected in this automatic fashion. The Multiplex Section protection mechanisms are coordinated by the K1 and K2 bytes in the Multiplex Section Overhead. Path protection is managed at a higher level by network management functions [21].

In SDH, the transmission is protected on optical sections from the Near End (the point at which the MS Overhead is inserted) to the Far End (the point where the MS Overhead is terminated). Bytes K1 and K2 in the MSOH of the STM-1 signal carry a MSP protocol used to coordinate protection switching between the Near End and the Far End [21].

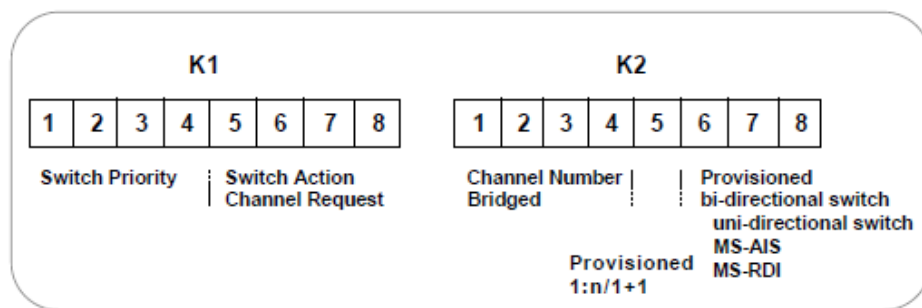

Figure 3.2: APS/ MSP, K1/K2 byte Functions [21].

The possible root causes for the APS state indication are [18]:

- An external command, including manual switching, forced switching and exercise switch, is issued;
- After the R\_LOS, R\_LOF, MS\_AIS,B2\_EXC, or B2\_SD alarm occurs, the MSP group changes to the switching state;
- The service board is faulty;
- The cross-connect board is faulty; and
- The attributes of the MSP group are incorrectly configured.

Of the total failure APS fails fourteen times (6%). This fault has an impact on the system such as the MSP switching fails and for linear MSP or two-fiber ring MSP, if a fiber cut or another fault occurs at this time, the services are interrupted.

### 3.1.1.1.R\_LOS (Receive loss of Signal) and R\_LOF (Receive Loss of Frame)

The most fundamental problem that could occur is that there is no signal at the physical interface. This condition will raise a Loss of Signal (LOS) alarm. Assuming the signal is present, the first task of the NE is to identify where the STM-1 frames are within the serial data. It does this by identifying the frame alignment word (FAW) which is contained in the first six bytes of the RSOH. If it cannot identify the FAW, a Loss of Frame (LOF) alarm will be raised.

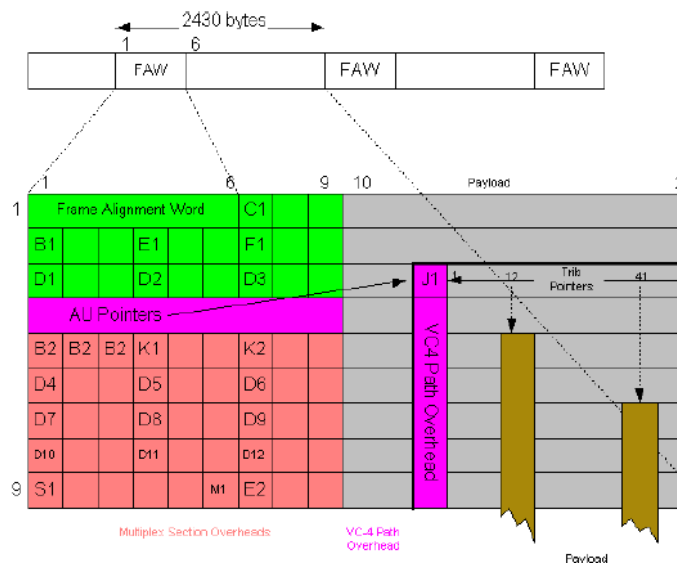

Figure 3.3: Basic SDH Processes [22]

When the R\_LOF alarm occurs, the services are interrupted, and the AIS signal is inserted in the downstream station. And also the system automatically returns the MS\_RDI (Multiplex section remote defect indication) alarm to the upstream station. Consequently, the upstream station reports the MS\_RDI alarm.

### 3.1.1.2. MS\_AIS (Multiplex section alarm indication signal)

LOS, LOF, and LOP alarms will render the whole signal unusable. In this case, the missing or corrupted signal is replaced by an AIS consisting of continuous binary 1s. This will produce AIS alarms on all equipment downstream of the fault. The NE detecting the fault also sends an indication to the distant (sending) end that an alarm has been raised. This raises a FERF (Far End Receive Failure) alarm at the appropriate level at the transmitting NE. Thus, a fault at the MS level will produce an MS-FERF. At the VC-4 level, it will produce a VC-4 FERF or, on some equipment, HO-FERFs. Some SDH elements refer to a remote alarm indication at some levels in the hierarchy.

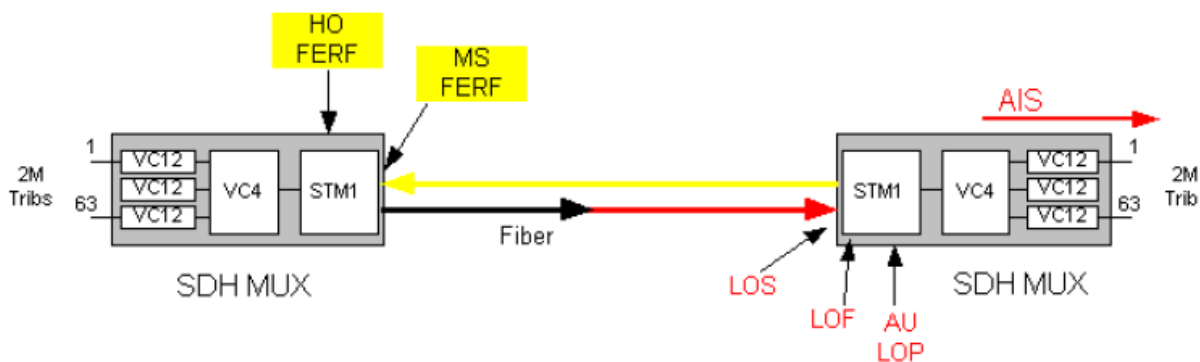

Figure 3.4: AIS and FERF at MS and higher order Levels [22]

The MS\_AIS is an indication alarm that occurs in the multiplex section. When the last three bits of the K2 byte are 111 in five frames consecutively received on the receive side of the local optical interface, the MS\_AIS alarm is reported. This alarm shows that the signals in the multiplex section corresponding to the optical interface that reports the alarm are useless. It's a major severity and communication alarm type [20], [22].

This alarm has an impact on the system such as: the services are interrupted and the board automatically returns the MS\_RDI alarm to the opposite station. Consequently, the opposite station reports the MS\_RDI alarm.

### **3.1.1.3.B2\_EXC (B2 excessive bit errors in multiplex section) and B2\_SD (B2 signal degrade in multiplex section)**

The B2\_EXC is an alarm indicating that the number of multiplex section B2 bit errors in the signals received on the line exceeds the specified value. When a line board detects that the BER of the regenerator section signals exceeds the specified threshold (default value:  $1 \times 10^{-3}$ ) for the B2\_EXC alarm by detecting the B2 byte, the B2\_EXC alarm is reported. It's a major severity and service alarm type [17].

The possible causes of the B2\_EXC alarm are as follows:

- The attenuation of the received signals is excessively high or low or the optical connector is loose or dirty.
- External environment is abnormal.
- The setting of the bit error threshold is improper.
- The receive board (including the cross-connect and timing board) of the local end is faulty.
- The transmit board (including the cross-connect and timing board) of the opposite end is faulty.

The B2\_SD is an alarm indicating that multiplex section B2 signals received on the line are degraded. When a line board detects that the BER of the regenerator section signals exceeds the specified B2\_SD alarm threshold (default value:  $1 \times 10^{-6}$ ) but is lower than the specified B2\_EXC alarm threshold (default value:  $1 \times 10^{-3}$ ), the B2\_SD alarm is reported. It's a minor severity and service alarm type.

The possible causes of the B2\_SD alarm are as follows:

- The attenuation of the received signals is excessively high or low; or the optical connector is loose or dirty.
- External environment is abnormal.

- The setting of the bit error threshold is improper.
- The receive board (including the cross-connect and timing board) of the local end is faulty.
- The transmit board (including the cross-connect and timing board) of the opposite end is faulty.

The B2\_EXC and/or B2\_SD alarm indicators has an impact on the system such as: the quality of the transmitted services is degraded; the system returns the M1 byte to the opposite end, showing the MS\_REI (Multiplex section remote error indication) alarm. Consequently, the opposite station reports the MS\_REI alarm.

#### **3.1.4. ETH\_LOSS (Loss of Ethernet interface connection)**

The ETH\_LOSS is an alarm indicating loss of network port connection. This alarm is reported when the Ethernet network port cannot receive Ethernet signals. It's a critical severity and communication alarm [17].

The possible root causes for the loss of Ethernet interface connection are [18]:

- The port is enabled, but the network cable or fiber of the network port is improperly connected;
- The network cable or fiber is faulty;
- The remote transmit end is faulty; and
- The local receive end is faulty.

Of the total failure the Ethernet loss occurred seventy eight times (or 32%). This will have an impact on the system such as: the network port cannot receive data and the services are interrupted.

- For the electrical interfaces, bidirectional services are interrupted.
- For the optical interfaces, different services are interrupted according to the work mode.
  - If the work mode is set to auto-negotiation, bidirectional services are interrupted.

- If the work mode is set to full-duplex mode, the services in the receive direction are interrupted.

### 3.1.5. IN\_PWR\_ABN (Input power abnormal)

IN\_PWR\_ABN is an alarm indicating that the input optical power is abnormal. It's a major severity and an equipment alarm type [17].

The possible root causes for the input power abnormal are [18]:

- The fiber is bent heavily;
- The fiber head is dirty;
- The fiber connector is loose;
- The transmit unit at the opposite station is faulty; and
- The receive unit at the local station is faulty.

Of the total faults it happens three times (or 1%). When the IN\_PWR\_ABN alarm occurs, it has an effect on the system such as the service transmission performance is affected. In the case of severe alarm, the services are interrupted.

#### 3.1.5.1. Fiber Bending Loss

Bending loss in the form of macro and micro-bending is a loss mechanism that contributes to loss as light propagates along the fiber. Micro-bend loss is due to microscopic fiber deformations in the core-cladding interface and is usually caused by poor cable design and fabrication [23]. Non-uniform lateral stresses during the cabling and the deployment of the fiber in the ground introduces micro-bends [23]. The effect of micro-bending is to increase optical loss.

Macro-bends are bends on a fiber having a large radius of curvature (bend)/ diameter relative to the fiber core diameter that is  $R \gg a$  where  $a$ , denotes the core radius, and  $R$  the radius of curvature [23]. Macro-bend losses are usually encountered during the in-house and installation process of the optic fiber. The effect of macro-bending is that the fiber may be bent to such a small radius to cause an increase in optical loss [24]. In single-mode optical fibers, the further the operational wavelength is from the cut-off wavelength, the less well-guided the mode will be, resulting in greater loss for the same fiber bend radius.

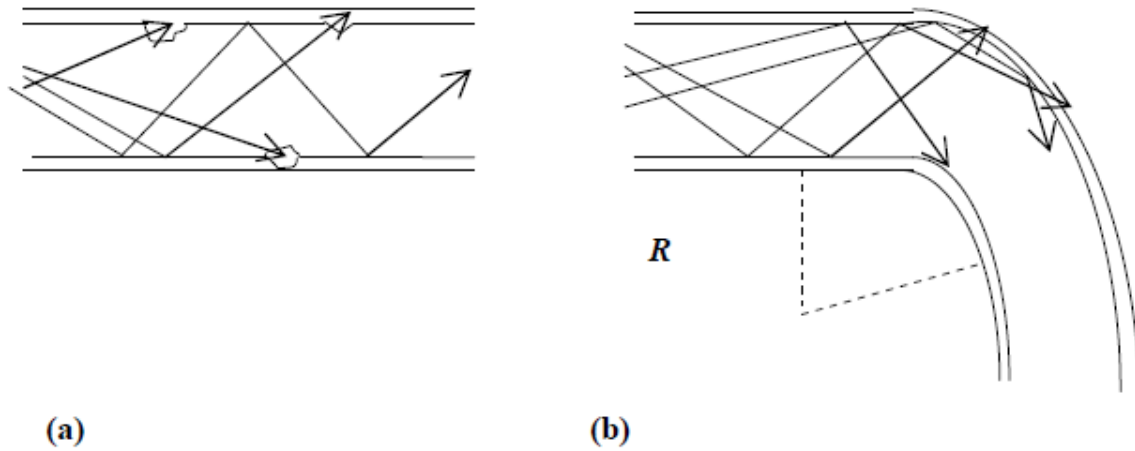

Figure 3.5: (a) Micro-bending; (b) Macro-bending [23]

Light can leak out of a fiber when the fiber is bent, as the bend becomes more acute, more lights leaks out. This effect is shown schematically in the figure below. In the figure on the left, a small percentage of the light is refracted out of the waveguide when it is bent. The figure on the right schematically illustrates that more light is shown refracted out of the fiber when it is bent to a smaller diameter [25].

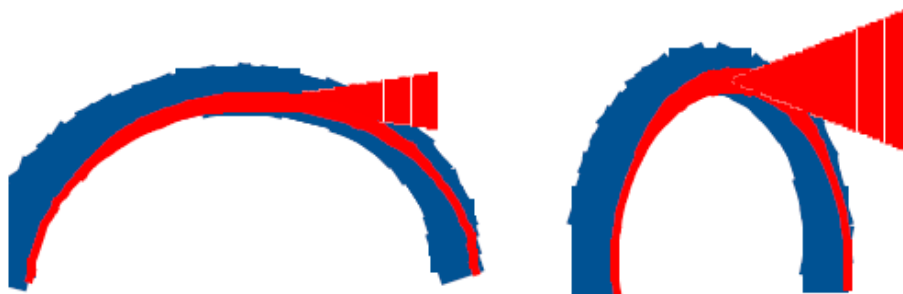

Figure 3.6: Macro-bending Schematic Diagram. When the fiber is bent from a straight deployment, some of the guided light is refracted out of the fiber. As the bend becomes more acute, more light is refracted out of the fiber [25].

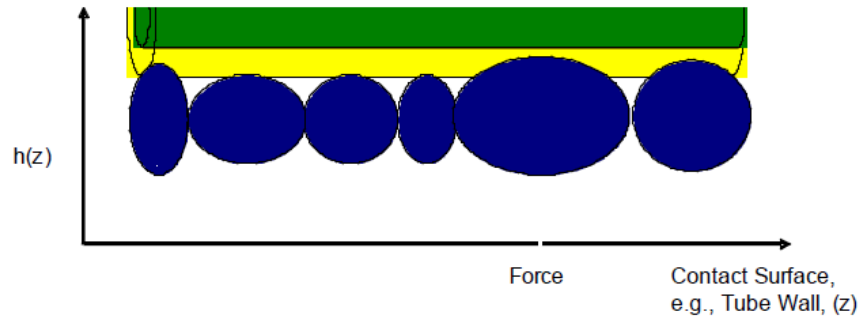

Figure 3.7: Schematic Representation of Micro-bending. Physical irregularities on the surface in contact with the fiber perturb it into small radius bends which can cause micro-bending [25].

There are three major types of optic fibers namely multimode fibers (MMF), single mode fiber (SMF) and plastic optic fiber (POF). Of these types the AALRT communication system uses for its transmission the single mode of fiber (SMF) [24].

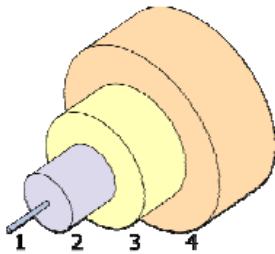

Figure 3.8: The Structure of a Typical Single-Mode Fiber [24]

1. Core: 8  $\mu\text{m}$  diameter
2. Cladding: 125  $\mu\text{m}$  dia.
3. Buffer: 250  $\mu\text{m}$  dia.
4. Jacket: 400  $\mu\text{m}$  dia.

The core diameter for a typical single-mode fiber is between 5  $\mu\text{m}$  and 10  $\mu\text{m}$  with a 125- $\mu\text{m}$  cladding. Since the AALRT optical cable transmission line adopted G-652 optical fibers and STM-16 transmission system is opened in the 1,310 nm window [12].

Single-mode fibers are used in applications in which low signal loss and high data rates are required, such as in long spans where repeater/amplifier spacing must be maximized.

Because single-mode fiber allows only one mode or ray to propagate (the lowest-order mode),

it does not suffer from modal dispersion like multimode fiber and therefore can be used for higher bandwidth applications. However, even though single-mode fiber is not affected by modal dispersion, at higher data rates chromatic dispersion can limit the performance [24].

### 3.1.6. FCS\_ERR (Frame Check Sequence Error)

FCS\_ERR is an alarm indicating that the frame check sequence (FCS) is incorrect. On the local station, perform an FCS check for the received frames encapsulated in Generic Framing Procedure (GFP) format. If any error occurs in the check, the alarm is reported. This alarm is generated only when the received service of the local station is the GFP service. Because the IDLE frame lacks the FCS field, if the IDLE frame is encapsulated in GFP format, the FCS check errors may occur. It's a critical and communication alarm type [17].

The possible root causes for the frame check sequence error are [18]:

- The encapsulation protocols are inconsistent, or the protocol parameters such as scrambling or not and negating or not are inconsistent;
- The bit error alarms such as BIP\_EXC, BIP\_SD, B3\_EXC, and B3\_SD are present on the link.

Of the total failure FCS\_ERR occurs seventy four times (or 2%). This affects the detection of some errors occurred on transmission in the frame, which results to the destination host receive an error frame and/or data which is not the same as the sender. And also it has an impact on the system such as:

- If the FCS\_ERR alarm is generated due to the inconsistent encapsulation protocols, the services are interrupted.
- If the FCS\_ERR alarm is generated due to bit errors in the system, packets are lost or services are interrupted.

#### 3.1.6.1. Encapsulation protocols are inconsistent or the protocol parameters such as scrambling or not and negating or not are inconsistent

The Mapping Protocol of the local station and the opposite station is inconsistent. This means that, the local station uses the GFP encapsulation protocol whereas the opposite station uses the

Link Access Procedure-SDH (LAPS) encapsulation protocol. Or the parameter configurations of the protocol are inconsistent; this means that, both stations use the GFP encapsulation but the Extension Header Option of the local station is set to Yes whereas the Extension Header Option of the opposite station is set to No.

### **3.1.6.2. The bit error alarms such as BIP\_EXC, BIP\_SD, B3\_EXC, and B3\_SD are present on the link.**

#### **3.1.6.2.1. BIP\_EXC (Bit Interleaved Parity Excessive Bit Errors ) and BIP\_SD (Bit Interleaved Parity Signal Degrade)**

The BIP\_EXC is an alarm indicating that the number of BIP bit errors exceeds the specified value. If a board detects that the number of BIP2 bit errors in the V5 byte exceeds the specified BIP\_EXC alarm threshold (default value:  $1 \times 10^{-3}$ ), the BIP\_EXC alarm is reported. It's minor severity and service alarm type [17].

The BIP\_SD is an alarm indicating that the BIP signals are degraded. If a board detects that the number of BIP2 bit errors in the V5 byte exceeds the specified BIP\_SD alarm threshold (default value:  $1 \times 10^{-6}$ ) and is lower than the specified BIP\_EXC alarm threshold (default value:  $1 \times 10^{-3}$ ), the BIP\_SD alarm is reported. It's a minor severity and service alarm type [17].

Each layer in the SDH signal provides alarm and error monitoring capabilities between various terminating points in the network. Similar to 2 Mbit/s signals, parity is calculated and stored in the transmitted signal [26].

The parity is recalculated by the receiver and verified against the stored value to determine if an error occurred during transmission. Every layer in the SDH signal has its own Bit Interleaved Parity (BIP) calculation.

BIP calculations are performed over each layer of the SDH overhead, such that each bit in the BIP byte will indicate the parity of all respective bits in the previous frame. For example, if the number of bits equaling one in the first bit position of every byte is odd, then the first bit position of the BIP byte will be one. If the number of ones in the first position is even, then the first bit position of the BIP byte will be zero. This is repeated for all eight bits of each byte to determine the value of the BIP byte.

Bytes in  
Transmitted Signal = 01100100  
10000110  
.....  
10100110  
BIP Calculation = 01000100

Each layer calculates the BIP for all information in its domain. For example, the entire SDH signal is formed when the RSTE sees it, so the regenerator section BIP is calculated over the entire signal, including all RSOH, MSOH, VC-4 POH, and payload of the previous STM-N frame. The result is then placed in the B1 byte for a STM-1. Multiplexer section BIPs are calculated over the previous STM-1 frame, minus the RSOH, and placed in the B2 bytes. Path BIPs are calculated over the previous frame, minus RSOH and MSOH, and are found in the B3 byte of every STM-1 [26].

The possible causes of the BIP\_EXC and/or BIP\_SD alarm are as follows:

- Higher-level bit error alarms are reported in the system.
- The BIP2 bit errors in lower order services are excessive.
- The transmit part of the board at the upstream station is faulty.
- The local board is faulty.

When the BIP\_EXC and/or BIP\_SD alarm is reported, it has an impact on the system which degrades the VC-12 service quality. And also BIP\_SD has an impact on the system such as: the quality of the services carried over the path of the board is degraded. And also the board returns the LP\_REI (Lower order path remote error indication) alarm to the opposite end.

#### **3.1.6.2.2. B3\_EXC (B3 excessive bit errors in higher order path) and B3\_SD (B3 Signal Degrade in Higher order path)**

The B3\_EXC is an alarm indicating that the number of higher order path B3 bit errors in the signals received on the line exceeds the threshold. When a line board detects that the BER of the higher order path signals exceeds the specified threshold (default value:  $1 \times 10^{-3}$ ) by detecting the B3 byte, the B3\_EXC alarm is reported. It's a major severity and service alarm type [17].

The B3\_SD is an alarm indicating that the higher order path B3 signals received on the line are degraded. When a line board detects that the BER of the higher order path signals exceeds the specified B3\_SD alarm threshold (default value:  $1 \times 10^{-6}$ ) but is lower than the specified B3\_EXC alarm threshold (default value:  $1 \times 10^{-3}$ ) by detecting the B3 byte, the B3\_SD alarm is reported. It's a minor severity and service alarm type [17].

The possible causes of the B3\_EXC and/or B3\_SD alarm are as follows:

- The attenuation of the received signals is excessively high or low; or the optical connector is loose or dirty.
- External environment is abnormal.
- The setting of the bit error threshold is improper.
- The receive board (including the cross-connect and timing board) of the local end is faulty.
- The transmit board (including the cross-connect and timing board) of the opposite end is faulty.

The B3\_EXC and/or B3\_SD has an impact on the system such as: bit errors occur in the path-level services, the system returns the G1 byte to the opposite end, showing the higher order path remote error indication (HP\_REI) alarm. Consequently, the opposite station reports the HP\_REI alarm.

If the AU\_AIS alarm is inserted when the B3\_EXC alarm is reported, the system returns the G1 byte to the opposite end, showing the higher order path remote defect indication (HP\_RDI) alarm. Consequently, the remote station generates HP\_RDI alarm.

### **3.1.7. NE Communication Break**

Network element (NE) is any device which is part of an SDH transmission path and serves one or more of the section, line and path-terminating functions. In SDH, the five basic network elements are: Add/drop multiplexer, broadband digital cross-connect, wideband digital cross-connect, flexible multiplexer and regenerator [26].

A network element (NE) contains both the hardware and the software running on it. One NE is at least equipped with one system control board which manages and monitors the entire network element. The NE software runs on the system control board [19].

The possible root cause for the network communication break is due to NE communication equipment fault [18]. Of the total failure the network element communication breaks occurred thirty three times (or 13%).

### **3.1.8. COMMUN\_FAIL (Inter-board Communication Fail)**

The COMMUN\_FAIL is an alarm of inter-board communication failure. This alarm is reported when the communication between the SCC and other boards is interrupted. It's a major severity and equipment alarm type [17].

The possible root cause for the inter-board communication fail is that the board is faulty and the board is reset [18]. Of the total failure inter-board communication failure happens four times (or 2%).

This failure has an impact on the system such as: When the alarm is generated, the host cannot send commands or services to the board, or the board cannot work. In this case, the service cannot be configured or the protection switching becomes invalid. Thus, the new added service becomes abnormal.

### **3.1.9. PS (Protection Switching indication)**

The PS is an indication alarm of protection switching. This alarm occurs after protection switching occurs on a service. It's a major severity and equipment alarm type [17].

The possible cause of the PS alarm is that protection switching occurs on a service [18]. Of the total failure it occurs seven times (or 3%). The protection switching indication has an impact on the system which is during the switching; the service is transiently interrupted for less than 50ms.

### **3.1.10. MS\_APS (Multiplex Section Automatic Protection Switching)**

The linear Multiplex Section Protection (MSP) switching event is triggered and then reported to the NMS when the current working path or protection path detects an alarm associated with [17] Signal Failed (SF) or Signal Degraded (SD). It's a major severity alarm and service alarm type.

The possible root cause for the multiplex section automatic protection switching is that the multiplex section switching causes the switching of services. Of the total faults it occurs twenty one times (or 8%). This has an impact on the system such as: this event prompts users to identify the cause of MSP switching. If a link fails, it should be repaired promptly. In this case, the working path and protection path of the linear MSP are in the idle state.

### **3.1.11. VCAT-LOM VC-4 (VC-4 virtual concatenation loss of multi-frame)**

The VCAT\_LOM\_VC4 is an alarm indicating the loss of the virtual concatenation multi-frame in the VC-4 path. This alarm occurs when the system detects that the multi-frame indicator (MFI) field in the H4 byte of the VC-4 timeslot is illegal. It's a major severity and communication alarm type [17].

The possible root causes for the VC-4 virtual concatenation loss of multi-frame are [18]:

- There are bit error alarms BIP\_EXC and BIP\_SD in the line;
- The virtual concatenation delay is over long; and
- The MFI field in the K4 byte transmitted from the opposite end is incorrect.

Of the total faults VCAT –LOM occurs twenty three times (or 9%). This will affect the benefit obtain from virtual concatenation (VCAT) that is, it provides a much more efficient use of the data transport bandwidth and it allows a more efficient use of the capacity of the different routes in the network. It has also an impact on the system such as:

- During the data transmission, if the line capacity adjustment scheme (LCAS) is enabled, the LCAS performs the automatic switching. Accordingly, the services are transiently interrupted.
- During the data transmission, if the LCAS is disabled, the services are interrupted.

### **3.1.12. AU\_AIS (Administrative Unit Alarm Indication Signal)**

The AU\_AIS is the administrative unit (AU) alarm indication. When the pointer value received on the receive side of the local optical interface is all "1"s, the AU\_AIS alarm is reported. It's a major severity and communication alarm type [17].

The possible root causes for the administrative unit alarm indication signal are [18]:

- a higher level alarm, such as R\_LOS, R\_LOF, R\_OOF, B1\_EXC or B2\_EXC, occurs in the system;
- The service is incorrectly configured;
- The AIS signal is transmitted at the opposite station; and
- The transmit unit (such as cross connect boards or line boards) at the opposite station is faulty.

Of the total faults the AU\_AIS happens eleven times (or 4%). This would have an effect on the system such as:

- When the AU\_AIS alarm is reported, the VC4 path-level services are interrupted if the network is not protected.
- In this case, the AU-AIS alarm is reported at the downstream station.

### **3.1.13. APS\_INDI (Automatic Protection switching Indication)**

The APS\_INDI is an alarm indicating the APS state. This alarm occurs when the multiplex switching protection is in the switching state. It's a major severity and communication alarm type [17].

The possible causes for the automatic protection switching indication are [18]:

- The service board is faulty,
- An external command including manual switching, forced switching, and exercise switching, is issued,
- After the R\_LOS, R\_LOF, MS\_AIS, B2\_EXC, or B2\_SD alarm occurs,
- The MSP group changes to the switching state, and
- The cross-connect board is faulty.

Of the total failure the automatic protection switching indication occurs four times (or 2%). This has an impact on the system such as:

- The APS\_INDI alarm indicates the occurrence of a fiber cut or a terminal node failure, which triggers the MSP switching.
- For a two-fiber ring MSP or a linear MSP, if a fiber cut or another fault occurs after the occurrence of this alarm, the services are interrupted.

#### **3.1.14. R-LOS (Receive Loss of signal)**

The R\_LOS is an alarm indicating loss of signal on the receive side of the line. It's a critical severity and communication alarm type [17].

The possible root causes for the receive loss of signal are [18]:

- The fiber jumper is not connected at the optical interface of the board;
- The laser of the board on the opposite station is shutdown;
- A fiber break occurs in the transmission line;
- The attenuation of the transmission line is overlarge;
- The transmit part of the opposite station is faulty; and
- The receive unit at the local station is faulty.

Of the total failure R\_LOS occurs three times (or 1%). The loss of signal has an impact on the system such as:

- When the R\_LOS alarm occurs, the services are interrupted, and the AIS signal is inserted at the downstream station.
- When the R\_LOS occurs, the system automatically returns the MS\_RDI (Multiplex section remote defect indication) alarm to the upstream station. Consequently, the upstream station generates the MS\_RDI alarm.

#### **3.1.15. EXT\_SYNC\_LOS (Loss of External Clock Source)**

The EXT\_SYNC\_LOS is an alarm indicating the loss of external clock source. This alarm is reported when the system detects the loss of the external clock source traced by the equipment. It's a critical severity and an equipment alarm type [17].

The possible root causes for the loss of external clock source are [18]:

- The physical interface for the external clock source loses signals;
- The input and output modes of the external clock source are inconsistency; and the clock input cable is incorrectly connected.

Of the total failure the loss of external clock source has occurred three times (or 1%). This affects for providing time signals to each subsystem of communications and unable to provide standard time signals to the systems in the light rail which require time synchronization signals.

And it has also an impact on the system such as: when the EXT\_SYNC\_LOS alarm is reported, the external clock source of the system is lost and cannot be traced by the equipment. Because the clock quality is lowered, the service quality may be affected, and pointer justifications and even bit errors may be generated.

### **3.2. Other Performance Problems of AALRT Communication System**

The project of the AALRT communication system is comprised of the transmission system, telephone system, radio communication system, video monitoring system and power communication system [12]. Of this system most of the problems occurred in the transmission system as discussed in the previous section of 3.1. On the contrary, on the other subsystem of the communication system there is no as such performance problems occurs. When the AALRT starts its operation there is a software problem in the radio communication system, but it is solved by upgrading the software. Other than this, there was a water leakage into the station of Mexico square station that is NE (EW18). Due to this, it burns out and damaged the installation. As a result of this the radio remote Unit (RRU) is damaged. This shows that there was lack of proper standard installation problems is present. In fact this fault happens not only by proper installation problem but some construction problems could be raised.

On the video monitoring system, the author observed during surveying and/or data collection for the performance problems, most of the cameras are installed in the whole line on the top of stations platforms, important level crossing of line, substation, and switch section of depot this exposed the cameras to heat and dust. And also, distance tolerance to transmit the video to the control center could affect the system due to the fact that there is only one video monitoring center installed in the whole line which is located at the building of the control center (Kality depot).

## Chapter Four

### Key Performance Index (KPI) Parameters

This chapter proposes a frame work of KPI parameters for assessing performance investigation and for effective maintenance of the AALRT communication system. Thus, the proposed framework allows a fine grain analysis and comparison of the different faults of major and critical alarm type, equipment, communication and service alarm type that has an influence, effect and impact on the performance of the AALRT communication system. The presented framework is being considered for standardization and is positioned to become an essential tool and back ground for scientific research in the coming near future in AALRT communication system for assessing performance investigation and effective maintenance.

#### 4.1. Proposed Key Performance Indicator (KPI) Parameters for the Transmission System

##### 4.1.1. Key Performance Index (KPI) Parameters for Power Failure

One of the performance problems of the transmission system is power failure, which is occurred five times (or 2%). Then, it fails to supply power for the communication system equipment at the control center, the substation and the vehicle section as discussed in section 3.1.1.

##### 4.1.1.1. KPI for Interruption

The IEEE standard 1366 defines a number of system indices, which is KPI, for quantifying the availability of distribution grid [27]. In general interruption is defined as “The loss of service to one or more of the communication subsystem such as the transmission system, telephone system, radio communication system and video monitoring system connected to the AC distribution box of each subsystem equipment cabinet in the communication equipment room”.

##### 4.1.1.2. KPI for standard interruptions

The following system KPIs are defined by the standard:

1. SAIFI (System Average Interruption Frequency Index). Defined as the ratio between the total number of the equipment of the communication subsystem interruptions and the

total number of communication subsystem equipment served from the system. The number of communication subsystem equipment is defined as the sum, over all the interruptions during one year, of the number of communication subsystem equipment's affected by each interruption. ( $N$  interruptions during a year, with interruption  $i$ , affecting  $C_i$  communication subsystem equipment,  $N_c$  the total number of communication subsystem equipment served). SAIFI measurement is mandatory.

$$SAIFI = \frac{C_i}{N_c} \dots\dots\dots (4.1)$$

Where  $C_i$  : is total number of communication subsystem equipment interruption.

$N_c$  : is total number of communication subsystem equipment served.

2. SAIDI (System Average Interruption Duration Index). Defined as the ratio of the total interrupted communication subsystem equipment minutes and the number of communication subsystem equipment's ( $D_i$  the duration of interruption  $i$ ). SAIDI measurement is mandatory.

$$SAIDI = \frac{D_i}{N_c} \dots\dots\dots (4.2)$$

Where  $D_i$ : is sum of all communication subsystem equipment interruption duration.

$N_c$ : is total number of communication subsystem equipment served.

3. CAIDI (Communication subsystem equipment Average Interruption Duration Index). This gives the average duration of an interruption as seen from the communication subsystem equipment.

$$CAIDI = \frac{D_i}{C_i} = \frac{SAIDI}{SAIFI} \dots\dots\dots (4.3)$$

Where  $D_i$ : is sum of all communication subsystem equipment interruption duration.

$C_i$  : is total number of communication subsystem equipment interruptions.

4. CTAIDI (Communication subsystem equipment Total Average Interruption Duration Index). It only considers that Communication subsystem equipment that actually experienced an interruption during a certain year. It is defined as CAIDI; only with denominator is equal to the number of communication subsystem equipment that experienced at least one interruption during a given year.
5. CAIFI (Communication subsystem equipment Average Interruption Frequency Index). It quantifies the number of interruptions experienced by those communication subsystem equipment that actually experienced interruptions. The value of the index indicates how much interruptions are experienced by the communication subsystem equipment.

$$CAIFI = \frac{C_i}{c} \dots\dots\dots (4.4)$$

Where  $C_i$  : is total number of communication subsystem equipment interruption.

$c$ : is total number of communication subsystem equipment who had at least one interruption.

6. ASAI (Average Service Availability Index). It gives the average percentage of time during which the communication subsystem equipment's has available power supply.
7. ASIFI (Average System Interruption Frequency Index). Interruptions are weighted by the amount of load affected ( $L_i$  be the load interrupted by interruption  $i$  and  $LT$  the total load supplied from the system).
8. ASIDI (Average System Interruption Duration Index). Interruptions are weighted by the amount of load affected.
9. CEMIn (Communication subsystem equipment's Experiencing Multiple Interruptions). It gives the fraction or percentage of communication subsystem equipment that experience more than  $n$  interruptions.

**4.1.1.3. KPI for short interruptions**

KPI for short interruptions that is momentary interruptions or a single opening/closing sequence of an interrupting device. The time between opening and closing should not exceed a maximum value, usually set at 5 min. Furthermore each momentary interruption event consists of one or more momentary interruptions. Duration-based classification is useful from customer point of view.

1. MAIFI (Momentary Average Interruption Frequency Index). It gives the count of momentary interruptions.

$$MAIFI = \frac{c_t}{N_c} \dots\dots\dots(4.5)$$

Where  $c_t$ : is total number of communication subsystem equipment interruptions less than the defined time.

$N_c$ : is total number of communication subsystem equipment served.

2. MAIFIE (Momentary Average Interruption Event Frequency Index). It counts the number of momentary interruption events.
3. CEMSMIn (Communication subsystem equipment’s Experiencing Multiple Sustained Interruptions and Momentary Interruption Events). It gives the fraction of communication subsystem equipment’s that experience more than  $n$  sustained interruptions and momentary interruption events. It takes into consideration both momentary and sustained interruptions.

**4.1.2. G.821 and G.826 Performance Analysis**

The quality of digital links is determined with the aid of bit error ratio tests (BERT). The results of such measurements must, however, be classified in some way, not least because the quality of a transmission path is often the subject of a contract between the network provider and the telecommunications user. For this reason, an objective means of classifying a line as either “good” or “bad” is required. The ITU-T Recommendations G.821and G.826 is internationally recognized standards that specify these parameters [10], [11].

**4.1.2.1.G.821 performance analysis**

This recommendation was originally specified for international circuit switched  $n \times 64 \text{ kbit/s}$  connections and expanded to include higher bit rates as time went on. A hypothetical reference connection is the basis used for determining quality parameters; this comprises an international long-distance segment, a national segment and a subscriber access segment.

G.821 definitions [11]:

- ❖ Errored second (ES): a one-second time interval in which one or more bit errors occurs.

- ❖ Severely errored second (SES): a one-second time interval in which the bit error ratio exceeds  $10^{-3}$ .
- ❖ Unavailable second (US): a circuit is considered to be unavailable from the first of at least ten consecutive SES. The circuit is available from the first of at least ten consecutive seconds which are not SES.

The original version of G.821 also included:

- ❖ Degraded minute (DM): a one-minute time interval in which the bit error ratio exceeds  $10^{-6}$ .
- ❖ Derived parameter: Error-free second (EFS): a one second time interval in which no bit errors occur.

#### 4.1.2.2. G.826 performance analysis

This recommendation, issued in 1933, takes higher bit rates into account and allows in-service measurement as it relies on the evaluation of block errors.

Error performance at the physical layer of digital communications equipment is a major factor in determining transmission quality. Here, it is discussed only the impact of the block-based error performance of transport systems. However, the impact of G.826 is difficult to evaluate directly since the performance recommendations are not given in terms of bit-error rate (BER) values. The recommendation ITU G.826 and G.821 [10], [11] defines qualitative parameters and final values for high-speed error transmission evaluation.

The specifications in G.826 apply end-to-end hypothetical reference path or connection having a length of 27000 km. There are no specific provisions for different transmission media (for example optical fiber, digital radio relay, and metallic cable and satellite transmission systems).

ITU G.826 recommendation follows four basic parameters for the block error rate valuation [10]:

- I. Errored Block (EB): a block which contains one, or more error bits;
- II. Errored Second (ES): limited period of one second, which contains one, or more error blocks;
- III. Severely Errored Second (SES): length interval of one second, which contains at least 30% of error blocks, or severely error limit period;

IV. Background block error (BBE): an errored block that is not a SES.

G.826 recommendation defines three relative error parameters, which acquires absolute values of the above quantities by error units measured.

- 1) Errored Second Ratio (ESR): the ratio of ES to total seconds in available time during a fixed measurement interval;
- 2) Severely Errored Second Ratio (SESR): is the ratio of SES to total seconds in available time during a fixed measurement interval;
- 3) Background Block Error Ratio (BBER): is the ratio of error blocks to total blocks during a fixed measurement interval, excluding all blocks during SES and unavailable time.

These error parameters are valid, assuming that the system is serviceable. According to ITU G.826 recommendation, in case at least 10 seconds with error rate bigger than  $10^{-3}$  follow one after another, the transmission system is not serviceable [10].

Table 4.1 specifies the end-to-end objectives for a 27500 km Hypothetical Reference Path (HRP) in terms of the parameters defined in 4.2.2. An international digital path at or above the primary rate shall meet its allocated objectives for all parameters concurrently. The path fails to meet the error performance requirement if any of these objectives is not met. The suggested evaluation period is 1 month.

Rate Mbit/s	1.5 to 5	> 5 to 15	> 15 to 55	> 55 to 160	> 160 to 3500	> 3500
Bits/block	2,000-8,000 (Note 1)	2,000-8,000	4,000-20000	6,000-20,000	15,000-30,000 (Note 2)	For further Study
ESR	0.04	0.05	0.075	0.16	(Note 3)	For further Study
SESR	0.002	0.002	0.002	0.002	0.002	For further Study
BBER	$3 \times 10^{-4}$	$2 \times 10^{-4}$	$2 \times 10^{-4}$	$2 \times 10^{-4}$	$10^{-4}$	For further Study

Table 4.1: End-to-end Error Performance Objectives for a 27500 km International Digital HRP at or above the Primary Rate [10].

Note 1: VC-11 and VC-12 paths are defined with a number of bits/block of 832 and 1120 respectively, i.e. outside of the recommended range for 1.5 to 5 Mbit/s paths. For these block sizes, the BBER objective for VC-11 and VC-12 is  $2 \times 10^{-4}$  [10].

Note 2: Because bit error ratios are not expected to decrease dramatically as the bit rates of transmission systems increase, the block sizes used in evaluating very high bit rate paths should remain within the range 15,000 to 30,000 bits/block. Preserving a constant block size for very high bit rate paths results in relatively constant BBER and SESR objectives for these paths [10].

Note 3: Due to the lack of information on the performance of paths operating above 160 Mbit/s, no ESR objectives are recommended at this time. Nevertheless, ESR processing should be implemented within any error performance measuring devices operating at these rates for maintenance or monitoring purposes [10].

#### **4.1.3. Performance events of an SDH Service**

Performance events of an SDH service are classified into three types: pointer justification, bit error and equipment function. But this thesis seeks only on the bit error and equipment functions performance events, due to the fact that the root causes for the performance problems as discussed in chapter three are equipment failure, communication failure and service failure alarm type.

A major factor in digital communications equipment like SDH service is the error performance at the physical layer. Here it is only the impact of the block-based error performance of transport systems is presented. However, the impact of G.826 is difficult to evaluate directly since the performance recommendations are not given in terms of bit-error rate (BER) values.

##### **4.1.3.1. Performance events for bit errors in regenerator sections**

- Regenerator section block of background error (RSBBE)
- Regenerator section errored second (RSES)
- Regenerator section severely errored second (RSSSES)
- Regenerator section unavailable second (RSUAS)

##### **4.1.3.2. Performance events for bit errors in multiplex sections**

- Multiplex section block of background error (MSBBE)

- Multiplex section errored second (MSES)
- Multiplex section severely errored second (MSES)
- Multiplex section unavailable second (MSUAS)

#### **4.1.3.3. Performance events for bit errors in higher order paths**

- Higher order path block of background error (HPBBE)
- Higher order path far end block of background error (HPFEBBE)
- Higher order path errored second (HPES)
- Higher order path severely errored second (HPSES)
- Higher order path unavailable second (HPFECSES)

#### **4.1.3.4. Performance events for bit errors in lower order paths**

- Lower order path block of background error (LPBBE)
- Lower order path far end block of background error (LPFEBBE)
- Lower order path errored second (LPES)
- Lower order path severely errored second (LPSES)
- Lower order path unavailable second (LPUAS)

#### **4.1.3.5. Ethernet service performance parameters**

Ethernet service performance events convey the transmission quality of the Ethernet services.

- Number of packet losses is over upper and under lower alarm threshold
- Number of the bytes of bad packets received is over upper and under lower alarm threshold
- Number of the bytes of bad packets transmitted is over upper and under lower alarm threshold
- Number of detected conflicts is over upper and under lower alarm threshold
- Number of check errors is over upper and under lower alarm threshold
- Number of frames delayed in transmitting is over upper and under lower alarm threshold
- Number of carrier errors detected is over upper and under lower alarm threshold
- Number of frames with FCS error, incorrect parity bit and incorrect address
- Number of data frames and control frames with FCS error

- Errored seconds (SE)
- Unavailable seconds (US)

#### **4.1.3.6. Optical Line Terminal (OLT) and Optical Network Terminal (ONT) KPI Parameters**

The optical line terminal (OLT) is a device that terminates the common (root) endpoint of an Optical Distribution Network (ODN), which implements a Passive Optical Network (PON) protocol, such as that defined in [28], and adapts PON PDUs for uplink communications over the provider service interface. The OLT provides management and maintenance functions for the subtended ODN and Optical Network Unit (ONUs).

The optical network termination (ONT) is a single subscriber device that terminates any one of the distributed (leaf) endpoints of an ODN, which implements a PON protocol, and adapts PON PDUs to subscriber service interfaces. An ONT is a special case of an ONU [28].

KPI's associated with OLT and ONT which gives performance specification about these network elements are described in the ITU-T recommendation series G.984.1 through G.984.4 [5], [24], [28]. These KPI parameters are mentioned below.

- Down Average Throughput, Down Frames, Down Discard Frames, Downstream BIP Error Frames, Frames Loss.
- Uplink Average Throughput
- Received Blocks, received Ethernet frames, received frames and received packets.
- Bit error rate (BER)
- Discarded packets, packet delay and packet loss.
- Network delay
- Resource availability, resource utilization
- Severely errored seconds (SES)
- Received broadcast frame, broadcast packet and multicast frame

## **4.2. Proposed Key Performance Indicator (KPI) Parameters for the Telephone Communication System of AALRT**

The telephone communication system of AALRT is composed of business and non-telephone business [12]. As observed currently throughout the performance investigation of the AALRT

communication system there is no as such performance problem that can be mentioned affecting the contact between management department, operating department and maintenance department. These cannot ensure that for the occurrence of a performance problem in the coming near future. If it is so it's important to state some important International Standard KPI parameters to assess the performance investigation of the telephone communication system in the coming future. Some useful KPI parameters for the telephone communication system are:

- 1) Average call holding time: This value is determined by taking the total length of calls during the busiest hour divided by the total number of calls.
- 2) Incoming response delay: This expresses the probability that an arriving customer will need to queue (as opposed to immediately being served).
- 3) Switchboard call congestion probability: This can be expressed as the probability that a call will be blocked or delayed.
- 4) Drop call probability: It is one of the key performance indicators (KPI) used to monitor the fraction of the telephone call drop due to technical reasons. It is defined as the probability that a call is terminated and is basically estimated from drop call rate by applying the Poisson probability distribution function. The number of drooped calls is calculated from the relation:

$$\text{Drop callrate} = \frac{\text{No. of dropped calls}}{\text{No. of call attempts}}$$

The probability of occurrence of the call dropping event (drop-call probability) based on the above formula is thus calculated using the Poisson mass probability function from Microsoft Excel.

- 5) Session Defect Ratio (SDR): In relation to the total number of call attempts, SDR is the percentage of call attempts receiving the response as server internal error or server timeout. It is the ratio of number of the call attempts which are associated with server error and total number of call attempt request.

### **4.3. Proposed Key Performance Indicator (KPI) Parameter for the Radio Communication System of AALRT**

Radio communication system of the AALRT is an important supporting measure to ensure traffic safety, to increase transportation efficiency and management level and to improve service quality

as discussed in chapter two of section 2.2. Even though, through surveying the performance investigation it cannot be mentioned a fault that could be a major problem but when the AALRT starts its operation there is a software problem in the radio communication system, but they solved this by upgrading the software.

Thus, some useful KPI parameters are required to assess and investigate the performance of the radio communication system for the coming near future. Since, the radio communication system of the AALRT communication meets the requirement of both data and voice transmission function, so digital communication system is considered [12]. As a result of this, the performance parameters of the radio communication system can be categorized into voice and data transmission system.

1) Performance parameters related to the voice transmission of the system are:

- Successful placed group calls (SPGC): Number of group calls that have been successfully established.
- Unsuccessful placed group calls (UPGC): Number of group calls in which a failure in the set up process happens
- Successful ended group calls (SEGC): Number of group calls that have been successfully ended.
- Unsuccessful ended group calls (UEGC): Number of group calls that are released before a user hangs up.

2) Performance parameters related to the data transmission of the system are:

- Messages sent by Dispatcher Work Stations (DWSs): Total number of Short Data Service (SDS) and status messages which are sent from dispatcher stations.
- Non-delivered messages sent by Dispatcher Work Stations (DWSs): Number of Short Data Service (SDS) and status messages which are sent from dispatcher stations and are not delivered to their destination.
- Messages sent by Radio Subscribers (RSs): Total number of Short Data Service (SDS) and status messages which are sent from subscriber equipment.

- Non-delivered messages sent by Radio Subscribers (RSs): Number of Short Data Service (SDS) and status messages which are sent from subscriber equipment and are not delivered to their destination.
- Successful received packets (SRP): Number of data packets that are received without errors by the base station.
- Corrupt received packets (CRP): Number of data packets with errors that are received by the base station.

#### **4.4. Proposed Key Performance Indicator (KPI) Parameters for the Video Monitoring System of AALRT**

The video monitoring system is the supporting equipment for modernizing the AALRT operation and management as mentioned in chapter two of section 2.3. Throughout the research there is no failure that could affect the monitoring and controlling of the operation and management of the AALRT system. But the author observed during surveying and/or data collection for the performance problems, most of the cameras are installed in the whole line on the top of stations platforms, important level crossing of line, substation, switch section of depot this could be exposed to heat and dust on the cameras. And also, distance tolerance to transmit the video to the control center could affect the system due to the fact that there is only one video monitoring center installed in the whole line which is located at the building of the control center (Kality depot). Thus it is important to state and/or mention some useful KPI parameters to assess the performance, to improve organization and management efficiency of operation, to ensure safe transportation of passengers on schedule by train.

KPI parameters of the video monitoring system are:

- 1) Image standard (PAL video standard),
- 2) Transmission time,
- 3) The rate of channel video,
- 4) Switching delay of the system, and
- 5) The Signal to Noise Ratio (SNR) which is a technical term used to characterize the quality of the signal detection of a measuring system. The SNR is given by the ratio of the light signal to the sum of the noise signals. It is expressed as a ratio or factor in units of decibels [dB].  $Ratio[dB] = 20 \cdot \log(ratio)$

#### **4.5. The Role of Proposed Key Performance Indicators (KPI) for AALRT Communication System Maintenance**

Key performance indicators (KPIs) for maintenance are utilized to evaluate the effectiveness of the maintenance carried out [29]. They compare the actual conditions with a specific set of reference conditions (requirements/targets). Maintenance KPI is a product of several measures (metrics) used for the measurement of maintenance performance [29], and is equipped with baselines and realistic targets to facilitate prognostic and/or diagnostic processes and justify associated decisions and subsequent actions at appropriate levels in the organization, to create value in the business process [30].

Thus, this paper hardly recommend to use the proposed KPI parameters that is explained through section 4.1 to 4.4, for the faults that is explained and/or discussed in the previous chapter of three. Because the proposed KPI parameters are useful based on the following facts:

- They supports the aim of AALRT communication system that is to meet the demand of operation and management the communication system must be safe, reliable and able to transmit various information such as voice, data, images, etc.[12]
- They drive reliability growth while guiding the choices for improving maintenance effectives and efficiency.
- They identify the issues causing maintenance effects and help to select the right strategy to either support or correct the actions producing the results.
- It is important that when selecting a range of maintenance KPI to pick those that lets us to improve both equipment reliability and maintenance performance.
- They helps to understand what maintenance is doing, what it is achieving for the AALRT operation and management system, and what more it can do to improve operational performance.

## Chapter Five

### Results and Discussion

The performance problems and failure data of the AALRT communication system is adopted from the network management center of Kailty depot [18] and data collection about system function, system schemes and configuration, major technical standards, system interfaces of the entire communication subsystems is obtained from the preliminary design of the Addis Ababa E-W and N-S Light Rail Transit [12].

The AALRT communication system is comprised of transmission system, telephone system, radio communication system, video monitoring system and communications power supply [12]. Of this system the majority of the performance problems are occurred in the transmission system. On the other systems, such as on the radio communication system there is a software problem at the beginning but it is solved now by upgrading the software and there is also a water leakage into the stations of Mexico square station, which damages the radio remote unit (RRU) due to proper standard installation and some construction problems. The cameras of the AALRT video monitoring system are exposed to heat and dust, because most of them are installed on the top of stations platforms, important level crossing of line and substations. Distance tolerance could be raised to transmit the video to the control center due to the fact that there is only one video monitoring center.

Most of the performance problems of the AALRT communication system (subsystem) are occurred in the transmission system such as:

- 1) Power failure: Of the total failure of the transmission system it is failed five times (or 2%).
  - Root causes: The standby power is off and the power board is failed.
  - Impact on the system: Fail to supply stable, reliable and uninterruptible power to each communication system (subsystem).

When the standby power is off it cannot ensure that the system can conduct uninterruptible working for some time and period of the standby power of the project is less than two hours.

It has also an impact on the system such as the system time is lost.

- 2) Fan failure: Of the total failure the fan fails thirty six times (or 14%).
  - Root causes: Fan is not switched on, the fan fails, the board and the back plane are poorly connected and the speed level of fan is stop.
  - Impact on the system: affects the air flow, cooling and dissipation of the heat generated by the equipment. The operating system at efficient levels increases the risk of sudden equipment failure. And NE may be damaged due to overheat; this would result in an interruption on the entire equipment services.
- 3) Automatic protection switching failure indication: Of the total failure it fails fourteen times (or 6%).
  - Root causes: An external command, including manual switching, forced switching and exercise switch, is issued; after the R\_LOS, R\_LOF, MS\_AIS, B2\_EXC, or B2\_SD alarm occurs, the MSP group changes to the switching state; the service board is faulty; the cross-connect board is faulty and the attributes of the MSP group are incorrectly configured.
  - Impact on the system: This fault has an impact on the system such as the MSP switching fails and for linear MSP or two-fiber ring MSP, if a fiber cut or another fault occurs at this time, the services are interrupted.
- 4) Loss of network port connection (ETH loss): Of the total failure the Ethernet loss occurred seventy eight times (or 32%).
  - Root causes: The port is enabled, but the network cable or fiber of the network port is improperly connected; the network cable or fiber is faulty; the remote transmit end is faulty; and the local receive end is faulty.
  - Impact on the system: the network port cannot receive data and the services are interrupted. For the electrical interfaces, bidirectional services are interrupted. For the optical interfaces, different services are interrupted according to the work mode. If the work mode is set to auto-negotiation, bidirectional services are interrupted. If the work mode is set to full-duplex mode, the services in the receive direction are interrupted.

- 5) Input power abnormality: Of the total faults it happens three times (or 1%).
  - Root causes: The fiber is bent heavily; the fiber head is dirty; the fiber connector is loose; the transmit unit at the opposite station is faulty and the receive unit at the local station is faulty.
  - Impact on the system: it has an effect on the system such as the service transmission performance is affected. In the case of severe alarm, the services are interrupted.
  
- 6) Frame check sequence error (FCS\_ERR): Of the total failure FCS\_ERR occurs seventy four times (or 2%).
  - Root causes: The encapsulation protocols are inconsistent, or the protocol parameters such as scrambling or not and negating or not are inconsistent; the bit error alarms such as BIP\_EXC, BIP\_SD, B3\_EXC, and B3\_SD are present on the link.
  - Impact on the system: It affects the detection of some errors occurred on transmission in the frame, which results to the destination host receive an error frame and/or data which is not the same as the sender. And also it has an impact on the system such as: If the FCS\_ERR alarm is generated due to the inconsistent encapsulation protocols, the services are interrupted. If the FCS\_ERR alarm is generated due to bit errors in the system, packets are lost or services are interrupted.
  
- 7) Network element (NE) communication break: Of the total failure it's occurred thirty three times (or 13%). Its root cause is when NE communication equipment faults.
  
- 8) Inter-board communication failure: Of the total failure it happened four times (or 2%).
  - Root cause: the board is faulty and the board is reset.
  - Impact on the system: When the alarm is generated, the host cannot send commands or services to the board, or the board cannot work. In this case, the service cannot be configured or the protection switching becomes invalid. Thus, the new added service becomes abnormal.
  
- 9) Protection switching (PS) indication: Of the total failure it occurred seven times (or 3%).
  - Root cause: when protection switching occurs on a service.
  - Impact on the system: during the switching; the service is transiently interrupted for less than 50ms.

10) Multiplex section automatic protection switching: Of the total faults it occurred twenty one times (or 8%).

- Root cause: the multiplex section switching causes the switching of services.
- Impact on the system: this event prompts users to identify the cause of MSP switching. If a link fails, it should be repaired promptly. In this case, the working path and protection path of the linear MSP are in the idle state.

11) VC-4 virtual concatenation loss of multi-frame: Of the total faults it occurred twenty three times (or 9%).

- Root causes: There are bit error alarms BIP\_EXC and BIP\_SD in the line; the virtual concatenation delay is over long; and the MFI field in the K4 byte transmitted from the opposite end is incorrect.
- Impact on the system: During the data transmission, if the line capacity adjustment scheme (LCAS) is enabled, the LCAS performs the automatic switching. Accordingly, the services are transiently interrupted. During the data transmission, if the LCAS is disabled, the services are interrupted.

12) Administrative unit alarm indication signal (AU\_AIS): Of the total faults the AU\_AIS happened eleven times (or 4%).

- Root causes: a higher level alarm, such as R\_LOS, R\_LOF, R\_OOF, B1\_EXC or B2\_EXC, occurs in the system; the service is incorrectly configured; the AIS signal is transmitted at the opposite station; and the transmit unit (such as cross connect boards or line boards) at the opposite station is faulty.
- Impact on the system: when the AU\_AIS alarm is reported, the VC4 path-level services are interrupted if the network is not protected. In this case, the AU-AIS alarm is reported at the downstream station.

13) Receive loss of signal (R\_LOS): Of the total failure it occurred three times (or 1%).

- Root causes: The fiber jumper is not connected at the optical interface of the board; The laser of the board on the opposite station is shutdown; a fiber break occurs in the transmission line; the attenuation of the transmission line is overlarge, the transmit part of the opposite station is faulty; and The receive unit at the local station is faulty.

- Impact on the system: the services are interrupted, and the AIS signal is inserted at the downstream station. And the system automatically returns the Multiplex section remote defect indication (MS\_RDI) alarm to the upstream station. Consequently, the upstream station generates the MS\_RDI alarm.

14) Loss of external clock source: Of the total failure it is occurred three times (or 1%).

- Root causes: the physical interface for the external clock source loses signals; the input and output modes of the external clock source are inconsistency and the clock input cable is incorrectly connected.
- Impact on the system: the external clock source of the system is lost and cannot be traced by the equipment. Because the clock quality is lowered, the service quality may be affected, and pointer justifications and even bit errors may be generated

Here, it is presented the total failure in tabular and graphical form with their percentage (see on the next page).

No.	Failure Type	Failure rate of 2015-2016 G.C.	Percentage (%)
1	Power Failure	5	2%
2	Fan failure	36	14%
3	APS failure	14	6%
4	Loss of ethernet connection	78	32%
5	Input power abnormal	3	1%
6	Frame check sequence error	4	2%
7	NE communication break	33	13%
8	Inter-board communication failure	4	2%
9	VC-4 virtual concatenation loss of multi-frame	23	9%
10	Administrative unit alarm indication signal	11	4%
11	APS_INDI	4	2%
12	Receive loss of signal	3	1%
13	Loss of external clock source	3	1%
14	Protection switching indication	7	3%
15	Multiplex section automatic protection switching	21	8%

Table 5.1: Performance Problems of the AALRT Transmission System (2015-2016 G.C.)

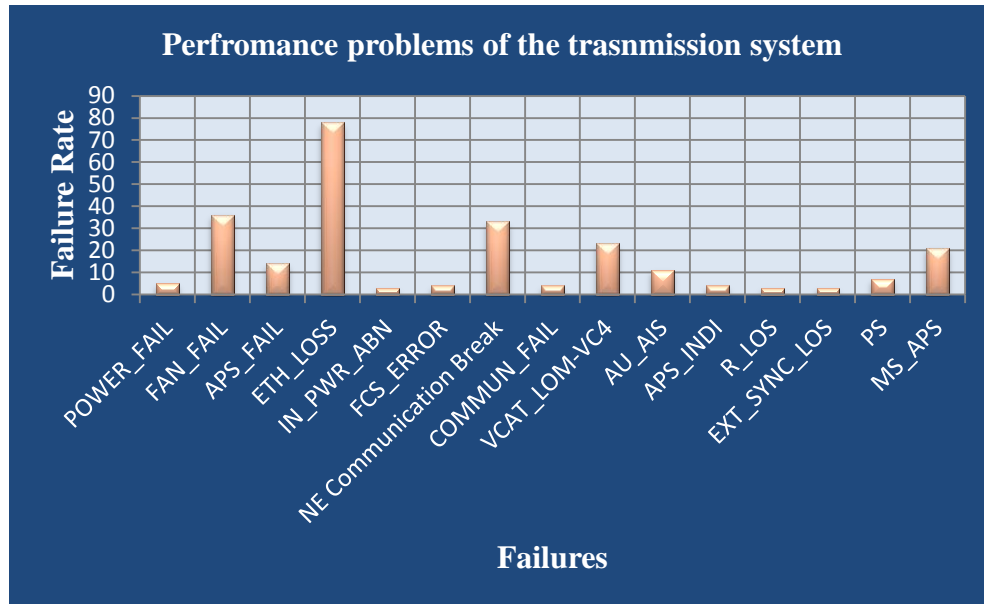

Figure 5.1: Graph of AALRT Transmission System Performance Problems of 2015-2016 G.C.

The major performance problems of the AALRT transmission system are occurred 65% of the total failure. These are power failure, fan failure, APS failure, input power abnormal, NE communication break, Inter-board communication failure, VC-4 virtual concatenation loss of multi-frame, Administrative unit alarm indication signal, APS\_INDI, Protection switching indication and Multiplex section automatic protection switching (see the figure below).

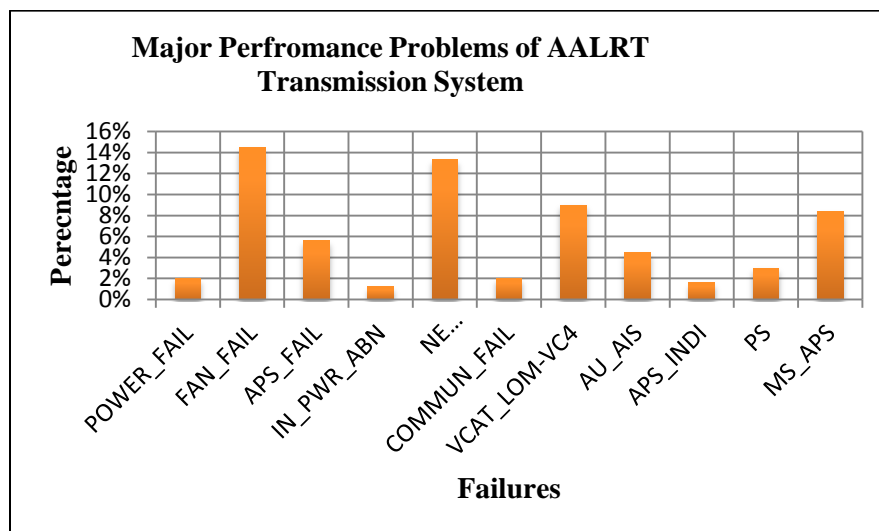

Figure 5.2: Graph of Major Performance Problems of AALRT Transmission System of 2015-2016 G.C.

The critical performance problems of the AALRT transmission system are occurred 36% of the total failure. These are Loss of ethernet connection, frame check sequence error, receive loss of signal and Loss of external clock source.

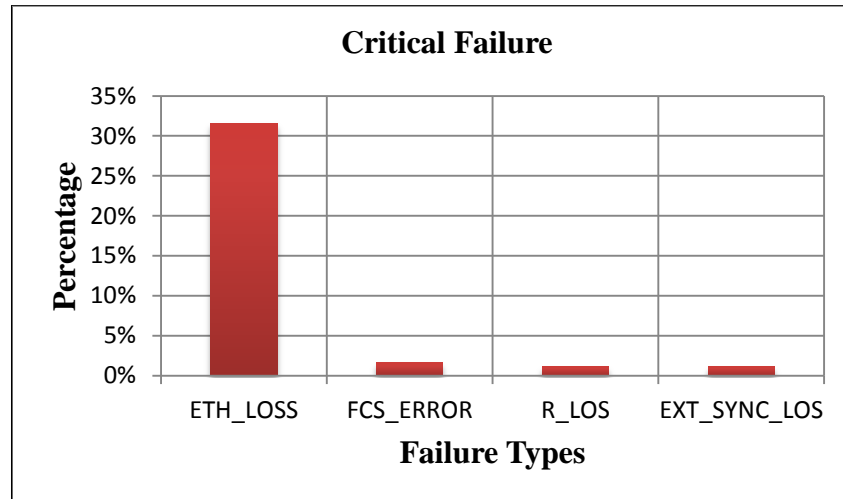

Figure 5.3: Graph of Critical Failure of AALRT Transmission System Problems of 2015-2016 G.C.

Of the total failure of the AALRT communication subsystem service failure alarm type is 8%, communication failure alarm type is 56% and equipment failure alarm type is 36% as shown below.

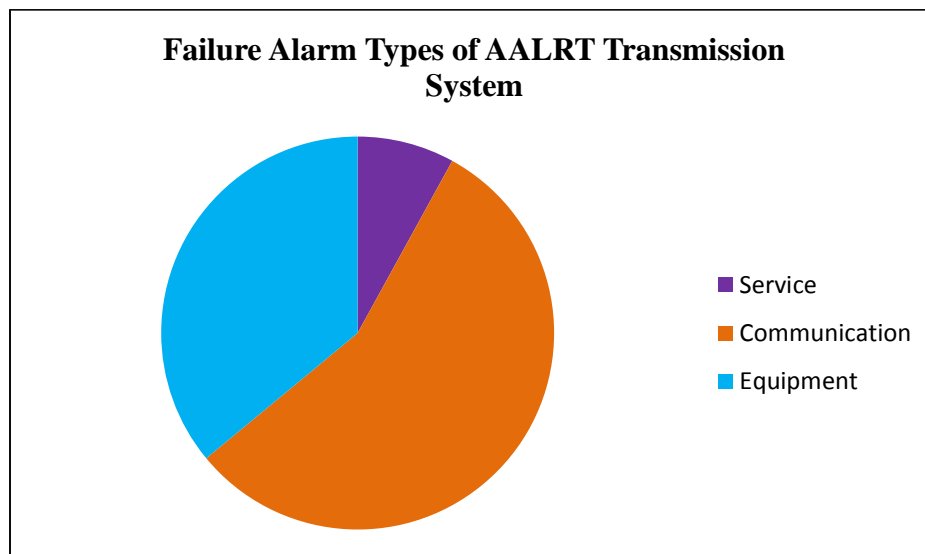

Figure 5.4: Graph of Failure Alarm Types of AALRT Transmission System of 2015-2016 G.C.

## Chapter Six

### Conclusion, Recommendation and Suggestion for Future Work

#### 6.1. Conclusion

This thesis found out and/or determine whether or not there was a performance problem requiring action in AALRT communication system and made an effort to identify those problems, analyzed and studied the root cause. From this research the author finds out a failure that has an impact on the operation and management of the different activities of the AALRT communication system. Most of the performance problems are occurred in the transmission system such as: 2% of power failure, 14% of fan failure, 6% of automatic protection switching failure, 32% of loss of Ethernet interface connection, 1% of input power abnormal, 2% frame check sequence error, 13% of network element communication break, 2% of inter-board communication fail, 9% of VC-4 virtual concatenation loss of multi-frame, 4% of administrative unit alarm indication signal, 2% of automatic protection switching indication, 1% of Receive loss of signal, 1% of loss of external clock source, 3% of protection switching indication, 8% of multiplex section automatic protection switching.

Of the total failure communication failure alarm type is 56%, service failure alarm type 8% and equipment failure alarm type is 36%. These performance problems and failures could affected the day to day activities of the AALRT such as unable to transmit quickly, accurately and reliably the information and/or data, voice, video, image that is needed for operation and management of all stations, depots, substations and the control center of the Project.

The paper proposed a frame work of KPI parameters for the performance investigation and effective maintenance of the AALRT communication system. These indices can be broadly attributed to the following categories: transmission system related indices, telephone system related indices, radio communications system related indices, video monitoring system related indices, and power system related indices.

Most of the proposed KPI parameters are extracted from the ITU-T recommendations G.826, G.821and G.984. They define a set of block-based error performance events and parameters devoted to in-service error performance monitoring of an SDH path. To mention some of these

parameters are EB, ES, SES and BBE. An errored block (EB) is one in which one or more bits are in error. An errored second (ES) occurs if there are one or more errored blocks or at least one defect such as a loss of pointer (LoP) during a one-second period. A severely errored second (SES) occurs if there are 30% or more EBs or a defect. SES is a subset of ES. Background block error (BBE) is an EB not occurring as part of an SES. Error performance parameters defined are severely errored second ratio (SESR), background block error ratio (BBER), and errored second ratio (ESR).

The proposed framework of KPI parameters is positioned to become an essential tool for assessing the performance of the AALRT communication system, for railway academic researchers and students specialized in the field of communication system and other related fields.

## **6.2. Recommendation and Suggestion for future work**

This thesis paper covered the system function, system interface, the system scheme and configuration of the communication system of the AALRT. It also deals with the performance problems of the communication subsystem and proposed a frame work of KPI parameters for the major and critical faults of communication system alarm types. This work needs greater investigation in order to make complete and practical in all aspects of fields, because for every research and/or thesis done, there is always a room for improvements and further enhancements. There are number of ways in which this work can be extended forward. The author recommends and suggests on the following points:

- This thesis is discussed only the impact of the block-based error performance of transport systems. However, the impact of G.826 is difficult to evaluate directly since the performance recommendations are not given in terms of bit-error rate (BER) values. Hence, the author recommends for the way and the procedure how to covert block error rates to BER should be studied.
- It should be better to study and analyze jitter performance of network interfaces of the AALRT transmission system. Because, jitter on network interfaces could accumulates on data paths according to the jitter generation and transfer characteristics of each

equipment's interconnected. This equipment's may be different types of multiplexers /de-multiplexers, cross-connects and line systems.

- Simulation package Cnet to analyze network behavior and performance modeling tools of OPNET should be used in order to find out the accomplishment of the data communication (transmission) system.
- Maintenance performance indicators (MPIs) for the railway communication system of equipment's and/or devices together with the identification and analysis for improvement of both equipment reliability and maintenance performance should be studied.
- Performance evaluation of the communication system of AALRT train control system using radio communication system should be studied, in order to improve the efficiency of their design for radio based train control system. And also to fully understand network performance including the effects of loads and delays in transmission of control information between devices. Therefore, the author suggests that to the railway academic researchers and students to try and develop a simulator for evaluating such network performance.
- The proposed key performance indicators (KPIs) can be applied and/or implemented for the optimization of the wireless and wired communication system of the AALRT. So that, KPI parameters for optimum value of the communication system should be studied.

## References

- [1] Aleksander 'Sniady, "Communication technologies support to railway infrastructure and operations," Ph.D. Thesis, Dept. Photonics Eng., Technical Univ. of Denmark, DTU Fotonik, May 2015.
- [2] José Darío Luis Delgado and Jesús Máximo Ramírez Santiago, "Key performance indicators for QoS assessment in tetra networks," International journal of mobile network communications & telematics (IJMNCT) Vol. 3, No.6, December 2013.
- [3] Joseph Isabona and Kingsley Obahiagbon, "A Practical optimization method to improve QOS and GOS-Based key performance indicators in GSM network cell cluster environment," International Journal of Wireless & Mobile Networks (IJWMN) Vol. 6, No. 5, October 2014.
- [4] Md. Nasir Uddin et al., "Performance analysis of different loss Mechanisms in optical fiber communication," Computer Applications: An International Journal (CAIJ), Vol.2, No.2, May 2015.
- [5] Qubit Giga passive optical network (GPON) KPI Kit Savitar Research Group
- [6] ITU-T Recommendation G.703 (1998, Oct.13). Physical/electrical characteristics of hierarchical digital interfaces, [Online]. Available: <http://www.itu.int>
- [7] ITU-T Recommendation G.707 (2007, Nov.13). Network node interface for the synchronous digital hierarchy (SDH), [Online]. Available: <http://www.itu.int>
- [8] ITU-T Recommendation G.783 (2006, March 29). Characteristics of synchronous digital hierarchy (SDH) equipment functional blocks, [Online]. Available: <http://www.itu.int>
- [9] ITU-T Recommendation G.774.01 (1993, March 12). SDH performance monitoring for the network element view [Online]. Available: <http://www.itu.int>
- [10] ITU-T Recommendation G.826 (1993, Dec 14). End-to-end error performance parameters and objectives for international, constant bit-rate digital paths and connections [Online]. Available: <http://www.itu.int>
- [11] ITU-T Recommendation G.821 (2002, Dec. 14). End-to-end error performance parameters and objectives for international, constant bit-rate digital paths and connections [Online]. Available: <http://www.itu.int>

- [12] Wang Cheng et al., “Addis Ababa E-W & N-S (Phase I) Light Rail Transit Project EPC (ET/ERC/CREC/0901) Preliminary Design”, China Railway Group Limited, Chapter XIII Communication System (Volume in One), June 2013.
- [13] Web ProForum Tutorials (June 1994). *Synchronous digital hierarchy (SDH) (1<sup>st</sup> ed.)* [Online]. Available: <http://www.iec.org> copy right© the International Engineering Consortium.
- [14] P. Michael Henderson. (2001, September 18). Fundamentals of SONET/SDH [Online]. Available e-mail: [mike@michael-henderson.us](mailto:mike@michael-henderson.us) Message: Get Fundamentals of SONET/SDH.
- [15] Alcatel Optical networks tutorial index (1998, June 02). [Online]. Available: <http://www.webproforum.com/alcatel/full.html>
- [16] William Stallings, “Data transmission,” in Data and Computer Communication, 8<sup>th</sup> ed., Inc. Pearson Prentice Hall Pearson Education, 2007, ch. 3, pp 66.
- [17] OptiX OSN 3500 Intelligent Optical Transmission System V100R008 (2010, Nov. 30) [Online]. Available: <https://www.scribd.com/document/277090782/OptiX-OSN-3500-Alarms-and-Performance-Events-Reference-V100R008-pdf>
- [18] Performance Problems of Addis Ababa Light Rail Transit (AALRT) Communication System from the Network Management Control Center of Kality Depot, 2015-2016 G.C.
- [19] OTA105103 OptiX OSN 3500 Hardware Description (2010, June 30) [Online]. Available: <https://www.slideshare.net/sanmap/sdhsonet-alarms-performance-monitoring>
- [20] Steve Gorshe, “A Tutorial on SONET/SDH automatic protection switching (APS) technology,” White Paper Principal Engineer Issue 1.0: February, 2005 © 2005 PMC-Sierra, Inc.
- [21] SDH telecommunications standard primer [Online]. Available: [www.tektronix.com/optical](http://www.tektronix.com/optical) Copyright © 2001, Tektronix, Inc. All rights reserved.
- [22] Cisco troubleshooting guide for synchronous digital hierarchy document ID: 5462 [Online]. Available: [http://www.cisco.com/warp/customer/127/sdh\\_overview.html](http://www.cisco.com/warp/customer/127/sdh_overview.html) all contents are Copyright © 1992-2004 Cisco Systems, Inc. All rights reserved.
- [23] Dorcas Nhiwatiwa, “Comparison of macro-bend losses in single mode fiber (SMF) and multimode fiber (MMF),” M.S thesis, Dept. of physics, faculty of science, university of Zimbabwe, January 2012.

- [24] Optical fiber, cables and system, ITU-T Manual © ITU 2010.
- [25] John A.jay (December 2010). An overview of macro-bending and micro-bending of optical fibers [Online]. Available: <http://www.corning.com/opticalfiber>
- [26] Wandel and Goltermann (2013). Pocket guide synchronous digital hierarchy (SDH) [Online]. Available: [www.jdsu.com/test](http://www.jdsu.com/test)
- [27] Henryk Markiewicz & Antoni Klajn, “Voltage disturbances standard EN 50160 voltage characteristics in public distribution systems,” European copper institute, Wroclaw University of Technology and Copper Development Association, Copyright© July 2004.
- [28] ITU-T Recommendation series-G (1995, July 10). Digital transmission systems Terminal equipment’s Operations, administration and maintenance features of transmission equipment [Online]. Available: <http://www.itu.int>
- [29] Wireman T., “Developing performance indicators in maintenance”, New York, Industrial Press (1998).
- [30] Liyanage et al., “towards a value-based view on operations and maintenance performance management,” Journal of Quality in Maintenance Engineering (2003).

## Appendix A: Terms and Definition

No.	Terms	Definitions
1	Synchronous Digital Hierarchy/ Synchronous Optical Networking (SDH/SONET)	SDH defined by the European Telecommunications Standards Institute (ETSI) for Europe. SONET defined by the American National Standards Institution (ANSI) and is used in North America. The basic unit of transmission in SONET is at 51.84 Mbps, but in order to carry 140 Mbps, SDH is based on three times this (i.e., 155.52 Mbps [155 Mbps]). Through an appropriate choice of options, a subset of SDH is compatible with a subset of SONET; therefore, traffic interworking is possible.
1	Add-drop multiplexer	An add-drop multiplexer is an important element of an optical fiber network.  Plesiochronous and lower bit rate synchronous signals can be extracted from or inserted into high speed SDH bit streams by means of ADMs. This feature makes it possible to set up ring structures, which have the advantage that automatic back-up path switching is possible using elements in the ring in the event of a fault.
2	Asynchronous Transfer mode	It is a form of fast short packet switching and multiplexing
3	Administrative unit	It is a managed entity within the SDH structure. It is the information structure which provides adaptation between the higher order path layer and the multiplex section layer. It consists of an information payload (the higher order VC) and a AU pointer which indicates the offset of the payload frame start relative to the multiplex section frame start
4	Synchronous transport module	It is the basic unit of transmission in SDH.
5	Virtual Container	It is the basic unit of payload together with its management overheads. It is the information structure used to support path layer connections in the SDH. It consists of information payload, and path

		overhead (POH) information fields organized in a block frame structure which repeats every 125 or 500 microseconds. Alignment information to identify VC frame start is provided by the server network layer.
6	Plesiochronous digital hierarchy	It is the widely deployed transmission system which predates SDH
7	section overhead	It is a group of management communications facilities in SDH.
8	Path overhead	Path overhead (POH): it has the task of monitoring quality and indicating the type of container. The format and size of the POH depends on the container type. The POH plus a container forms a virtual container.
9	Regenerators	Regenerators have the job of regenerating the clock and amplitude relationships of the incoming data signals that have been attenuated and distorted by dispersion. They drive their clock signals from the incoming data stream
10	Block	A block is a set of consecutive bits associated with the path; each bit belongs to one and only one block. Consecutive bits may not be contiguous in time.
11	Errored Block	Errored Block (EB) is a block in which one or more bits are in error.
12	Errored Second	Errored Second (ES) is a one-second period with one or more errored blocks or at least one defect.
13	Severely Errored Second	Severely Errored Second (SES) is a one-second period which contains 30% errored blocks or at least one defect.
14	Background Block Error	Background Block Error (BBE) is an errored block not occurring as part of an SES.
15	Severely Errored Period	Severely Errored Period (SEP) is a period of time during which at least three but not more than 9 consecutive severely errored seconds (SES) occur.

## Appendix B: SDH Error and Alarm Monitoring

Several alarm and error messages are integral to SDH networks where they are referred to as defects and anomalies, respectively. They are coupled with network sections and the corresponding overhead information. This section discusses the advantage of this detailed information.

Complete circuit failure can cause a loss of signal (LOS) alarm in the receiving NE that triggers subsequent messages or alarm indication signals (AIS). The transmitting side learns of the failure when it receives the remote defect indication (RDI) alarm. The alarm messages are transmitted in fixed bytes in the SOH or POH; for example, byte G1 is used for the HP-RDI alarm.

The figure below is an overview of major defects and anomalies [24].

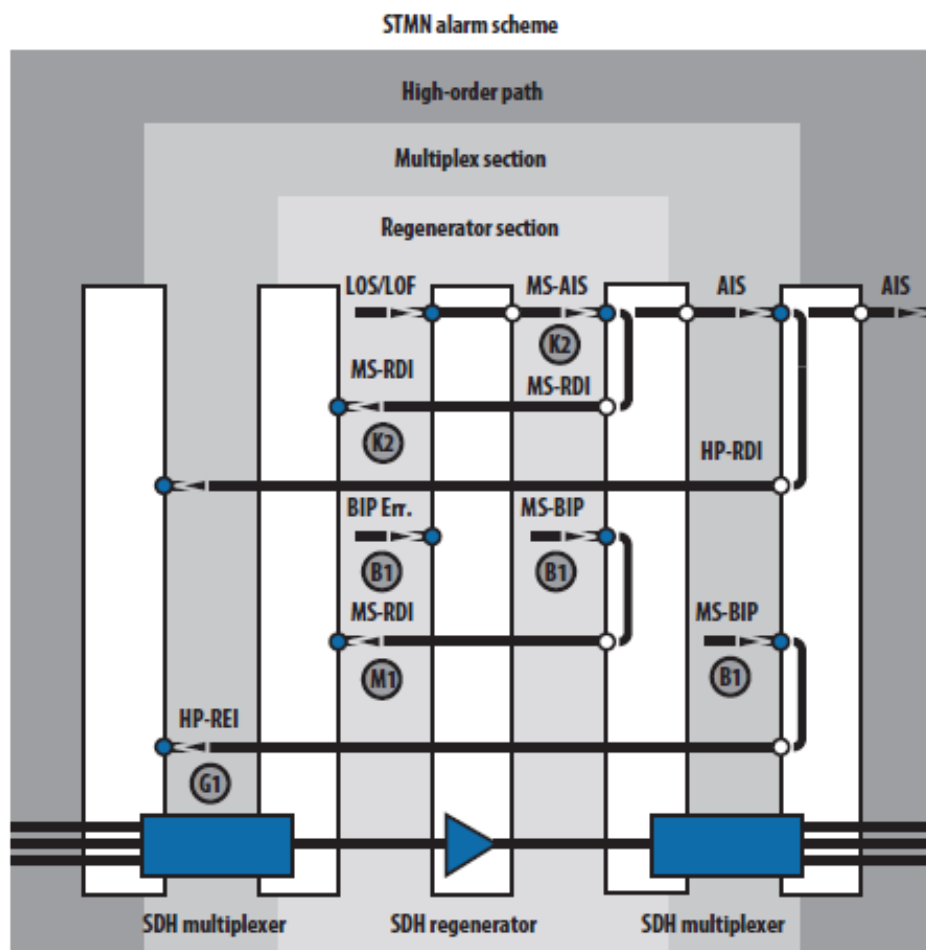

If the received signal contains bit errors, the sensor indicates BIP errors, which differs from a complete circuit failure. Therefore, this alarm is referred to as an anomaly and is indicated back toward the transmission's origin. The return message or is called a remote error indication (REI).

### Alarm and Layers

Each defect indication is associated with a layer.

