

**ADDIS ABABA UNIVERSITY
ADDIS ABABA INSTITUTE OF TECHNOLOGY
SCHOOL OF GRADUATE STUDIES
ENERGY CENTER**



**Biogas system planning for rural households
based on energy demand
(The case of Holeta district)**

A thesis submitted to the school of graduate studies of Addis Ababa
University in the partial fulfillment of the requirement for the degree of
Masters of Science in Energy technology

By: Mesfin Debebe

Advisor: Dr.Eng. Abubeker Yimam

2017

Addis Ababa, Ethiopia

ADDIS ABABA UNIVERSITY
ADDIS ABABA INSTITUTE OF TECHNOLOGY SCHOOL OF
GRADUATE STUDIES
ENERGY CENTER

Biogas system planning for rural households based on energy demand
(The case of Holeta district)

By: Mesfin Debebe

Approved by board of examiners	Date	Signature
1. Mr. Fitsum Salehu
(Chairman)		
2. Dr. Eng. Abubeker Yimam
(Advisor)		
3. Dr. Solomon Kirose
(Internal Examiner)		
4. Dr. Feleke Zewge
(External examiner)		

ABSTRACT

This research is conducted to study the energy consumption trend and to make easy of planning the biogas system design which can help to meet the energy demand of the rural households found in Holeta district. The energy demand of the households is assessed based on the questionnaire paper. The information of the assessed households is collected randomly from different family sizes that live in “Geda Jogo” and “Ada odo” Villages. Households are using electricity mostly for lighting purpose. Fire wood, Charcoal and dung cake are the main sources of energy to meet the cooking Energy demand. The average amount of annual fertilizer consumption by the peasant households is 220 kg.

Spreadsheet modeling tool is prepared and it is used to estimate Households biogas demand, gas production potential of the households and Digester volume including the expected Loading rate. It is also used to forecast the basics of Economical aspects which should be known before the plant is designed. To crosscheck the proper functionality of the spreadsheet modeling tool Manual calculations has been performed for the average and peak values observed in the surveyed households and compared with the values found from the spreadsheet model. For the average values, *the Biogas demand*, the *gas generating potential of the Households* and *digester volume* observed in the spreadsheet calculation tool are $6.001\text{m}^3/\text{day}$, $6.8\text{ m}^3/\text{day}$ and 20.3949 m^3 respectively. The values gained using manual calculations are $6.114\text{m}^3/\text{day}$, $6.8\text{m}^3/\text{day}$ and 20.4 m^3 .

For the peak values calculation in spreadsheet modeling tool, the Biogas demand, the gas generating potential of the Households and the digester volume needed are $9.19\text{m}^3/\text{day}$, $8.8\text{ m}^3/\text{day}$ and 26.3934 m^3 respectively. Where as in the manual calculation the values are $9.16\text{ m}^3/\text{day}$, $8.8\text{m}^3/\text{day}$ and the digester volume is 26.399 m^3 . Priority rank on the households energy demand has been performed, so that it will help on the biogas system design. The economical aspect of the biogas system is also included and how the households could be benefited using this technology. The estimated cost to construct the plant for the average values are ETB 29,840 with a payback period of 3 years. The cost spent to buy chemical fertilizer could be saved. Finally the benefit cost ratio is calculated to be 1.44 which is greater than 1.

AKCNOWLEDGEMENT

Above all my greatest thanks, praise and worship are for Almighty God whom I can't compare with anyone else and who gave me uncountable perfect gifts.

I want also to acknowledge everyone who helped me accomplish my research paper. My special appreciation and gratitude for my advisor and school Dean of Chemical and Bio-Engineering department of Addis Ababa university institute of Technology (AAiT), Dr.Eng Abubeker Yimam for every support he put during my research, for encouraging me and for his effort to help me work hard through the paper. I want also to thank very much my instructors and staff members in the Energy Center of Addis Ababa university institute of Technology (AAiT) and the Department head Dr. Solomon Abebe for every good help I get in the Center.

My beloved family and friends are also whom I can't forget in this special achievement. I have special thanks for my loving dad Debebe Abebe and also for my loving mom Tsehay Markos for every good care and love I get under their shade. I want also to acknowledge and thank so much my special family members Mr. George Lammers and his wife Mrs. Jean G.Lammers from U.S.A who supported me during my University journey.

My best friends Meheretab Abate and Belay Tegegn, I would like to thank you very much for being there every time I need your help. I would like to thank everyone who stands by my side during my post graduate school. Finally, my class mates of the post graduate school, I will not forget the good memories we had together and I hope that we will work together for the development of our Loving country Ethiopia.

TABLE OF CONTENTS

ABSTRACT	i
AKCNOWLEDGEMENT	ii
TABLE OF CONTENTS	iii
LIST OF FIGURES	vi
LIST OF TABLES.....	vii

CHAPTER ONE: INTRODUCTION..... 1

1.1 Statement of Problem.....	3
1.2 General objective	4
1.3 Specific objectives	4
1.4 Significance of the study.....	4
1.5 Scope and limitations of the study	4

CHAPTER TWO: LITRATURE REVIEW 6

2. Types of Biomass Fuels.....	6
2.1 Rural households' Traditional Energy Utilization.....	7
2.1.1 Household Energy Use.....	7
2.1.2 Local Energy Consumption and Sources	9
2.2 Disadvantages of Traditional Energy Utilization System	9
2.2.1 Defect of traditional system	9
2.3 Renewable Energy	10
2.4 Biogas.....	10
2.5 Anaerobic digestion	14
2.6 Spread sheet modeling as a Design planning tool.....	15
2.6.1 Spread sheet models as a decision-making tool.....	15
2.7 The history of biogas production	16
2.7.1 Different Types of AD of Animal Wastes in USA	17
2.7.2Different Types of Biogas Plant in Europe	18
2.8 Digester Technology	19
2.8.1 The joint co-digestion biogas plants.....	19

2.8.2 The farm scale biogas plants	20
2.8.3 Biogas in developing countries	21
2.8.4 Different types of biogas plants.....	21
CHAPTER THREE: MATERIALS AND METHODS	25
3.1 Sample size and sampling procedures.....	26
3.3 Questions included in the survey	26
3.2 Data collection Methods:	27
3.2.1 Secondary data.....	27
3.2.2 Primary data.....	28
3.3 Data Analysis Methods	29
3.5 Energy demand and Bio-gas system Design.....	29
CHAPTER 4: DATA ANALYSIS AND PRESENTATION.....	32
4.1 Source and uses of energy.....	32
4.2 Consumption and Price of Energy	33
4.2.1 Household fuel wood consumption:	33
4.2.2 Charcoal consumption	34
4.2.3 Dung cake consumption	35
4.2.4 Kerosene consumption.....	35
4.2.5 Recent trend of Price, Time and distance of Collection	35
4.3 Electricity	36
CHAPTER FIVE: BIOGAS SYSTEM DESIGN PLANNING TOOL.....	38
5.1 Flow chart for Biogas system Modeling	40
5.2 Model calculations	41
5.2.1 Biogas Demand (D).....	41
5.2.2 Bio gas production (G)	42
5.2.3 Digester volume (Vd).....	43
5.3 Using the Model for Analysis	43
5.3.1 Modeling report for the average values.....	44
5.3.2 Modeling report for the Pick values	46

5.4	Checking the Model with calculation	48
5.4.1	Daily gas demand (D).....	48
5.4.2	Biomass supply/Biogas production (P)	52
5.5	Sizing the Digester	53
5.6	Balancing the biogas production and demand	54
5.6.1	Pick value.....	54
5.7	Plant parameters	57
5.7.1	Specific gas production G_p	57
5.7.2	Digester loading L_d	57
5.8	Sizing the Gasholder	58
CHAPTER SIX: ECONOMICAL ASPECTS OF BIOGAS		62
6.1	Construction Materials and Costs	63
6.2	Financial Analysis.....	63
6.3	Economic Analysis	65
CHAPTER SEVEN: CONCLUSION.....		68
CHAPTER EIGHT: RECOMMENDATION.....		69
REFERENCES		

LIST OF FIGURES

PAGE NUMBER

Figure 1 Floating Drum digester18

Figure 2 Monthly fire wood consumption28

Figure 3.Monthly charcoal consumption and price29

Figure 3.Yearly Fertilizer consumption and Price of Households32

Figure 4 Basic dimensions of the digester45

LIST OF TABLES

PAGE NUMBER

Table 3 Electricity consumption36

Table 4. Average values 37

Table 5 Organized data from the survey for calculation 49

Table 6 Summary of Biogas demand 52

Table 7. Calculating parameters for fixed-dome biogas plant 59

Table 8 Average prices of monthly fuel consumption 62

Table 9 Cost estimation of construction..... 63

Table 10 Economic Analysis 66

LIST OF SYMBOLES

A	Annual benefit
AD	Anaerobic Digestion
As	annual saving
B	Biomass
B: W	ratio of Biomass to Water
BCR	Benefit cost ratio
C _b	Organic matter converted into biogas
CHP	Combined Heat and Power
D	Biogas Demand
G	Daily gas production
G _p	Specific gas production
HH	Households
Hr/day	Hour per day
L	Liters
L/hr	Liters per hour
L _a	Loaded amount of substrate
L _d	Digester Loading rate
L _{dv}	Daily volatile solids input Loading rate
LPG	Liquefied Petroleum Gas
MSW	Municipal solid waste
NPV	Net Present Value
O _{fp}	Price of organic matter from the digester
O _m	Organic matter gets out from digester
P	Biogas production
P _b	Total benefit during the lifetime of the project
P _c	present cost
R _T	Retention time

S _d	Daily substrate
SPP	Simple payback period
TS	Total solid
V _d	Digester volume
VS	Volatile solids
W	Water
A	Annual cost
B _a	Annual benefit
B _{ab}	Annual benefit from Biogas
B _{af}	Annual benefit from organic fertilizer
C _a	Annual cost
G _h	Hourly gas production
I _c	Initial cost
V _{Cmax}	Maximum gas consumption [m ³]
V _{g1}	Consumption volume
V _{g2}	Storage volume
g _{Cmax}	Maximum hourly gas consumption m ³ /h meter cube per hour
g _{Cmax}	Peak consumption rate
r	Discount rate
t _{Cmax}	Time of maximum consumption [h]
t _{Zmax}	Maximum zero-consumption time

CHAPTER ONE: INTRODUCTION

According to World Bank data 81% of Ethiopia's total population (~90,000,000) was comprised of people living in rural areas of the country. While access to electricity service coverage has increased 13.2% between 2009 and 2013, approximately 70% of Ethiopian households continue to depend on biomass energy (wood, dung, sawdust) for cooking (Growth and Transformation Plan II (GTP II), 2016).

While this traditional technique adds to Ethiopia's deforestation crisis (~12% forest area coverage left), indoor air pollution claims thousands of lives each year (World Bank, 2016). Women and children are most negatively impacted as they are constantly exposed to "black carbon" smoke inhalation. This unsustainable practice of deforestation and biomass burning ultimately adds to the overall global climate change issue. However, Ethiopia is especially vulnerable to climate change but has barely contributed to greenhouse gas emissions and the overall global climate change problem on an aggregate level. (Jamila Gilliam, 2016)

Modern biomass energy, like biogas energy produced by anaerobic digestion is widely used in many industrialized countries as well as in parts of the developing world. In suitable climatic zones, and with proper management backed by adherence to appropriate ecological practices, modern biomass can be a suitable source of electricity as well as liquid and gaseous fuels. Biomass, therefore, is not only a vital source of energy for many today, but is likely to remain an important source of energy in the future, provided suitable ways of sustainable exploitation are employed.

Biogas is a clean, sustainable alternative energy source to biomass. It is a combination of gases (methane and carbon dioxide) produced through the anaerobic breakdown of organic matter (e.g., animal or human waste, food waste or plant material) ultimately creating energy. Biogas energy can be used for cooking, heating, electricity. Biogas is also considered favorable from a financial perspective as it has generally low capital requirements, especially when compared to "conventional centralized power systems" (Mwirigi et al., 2014; Karekezi, 2002)

Anaerobic digestion of biodegradable wastes for production of biogas is widely studied subject. Properly functioning biogas systems can yield a whole range of benefits for their

uses including production of heat, light and electricity, transformation of organic waste into high quality fertilizer, improvement of hygienic condition and environmental advantages through protection of soil, water and air (Tafdrup, 1995).

Biogas is a naturally occurring byproduct of decaying plant and animal material. It is often found in bogs, wetlands, and even landfills. The process can be duplicated in biogas generators using bacteria to break down organic material such as agricultural, municipal, and industrial wastes of varying types. The resulting methane gas is an efficient source of energy for cooking, combustion engine, and burned to produce electricity. It is a remarkable process that turns waste into energy (Kellner, 2007).

In the last two and a half decades, around 1000 biogas plants were constructed in various parts of the country. Presently, approximately 40 % of these plants are not operational due to a lack of effective management and follow-up, technical problems, loss of interest, reduced animal holdings, evacuation of ownership and water problems. Other reasons for the limited success of the technology in Ethiopia include the adoption of a project-based stand-alone approach without follow-up structure in place, variations in design, and the absence of a standardized biogas technology. (National Biogas Program, Ethiopia)

For Ethiopia, livestock plays an important role as an agriculture-dependent country, where there has been little experience in biogas systems due to the aforementioned problems and issues. Animal and human excreta are generally available within rural areas, and there is a potential for larger biogas digester program for cooking, lighting and other purposes within the country. Thus, currently Ethiopian Rural Energy Development and Promotion Center (EREDPC) and Netherlands Development Organization (SNV) have set up a national Biogas Program (NBP), and completed a feasibility study of a support program for domestic biogas plants in rural households in Ethiopia (Boers, *et al.*, 2007).

1.1 Statement of Problem

The Energy consumption rate of the households is most of the time much greater than the designed gas generating potential of the biogas plant they own in the house. The gas generating potential of most biogas plants could be designed in a proper way to meet most of the fuel demand of the households.

The imbalance between the demand and gas production is a problem most biogas plants face due to a lack of good planning stage in the plant designing process. If we correctly identify the energy demand of the households, we can design the plant with a gas generating potential that can satisfy the demand to a larger extent by considering the available feedstock from cattle. Such study will help the potential of the biogas technology exploit to its fullest extent in a way to change the lives of rural households.

Design of biogas plants must start with an estimation of the quantitative and qualitative energy demand of the households. Then, the biogas generating potential must be calculated on the basis of the given biomass measures and compared to the energy demand. Both the energy demand and the gas-generating potential, however, are variables that cannot be very accurately determined in the planning phase. In the case of a household size bio-gas plant intended primarily as a source of energy, implementation should only be recommended, if the plant can be expected to cover the calculated energy demand.

Research Questions

Since determination of the biogas production volume depends in part on the size of the biogas plant, the present thesis answered the following related questions

- How rural households are meeting their Energy demand and how much is their fuel demand?
- How can we address households Energy demand with the available feed stock from cattle?

1.2 General objective

The overall objective is to study a biogas system of the rural households on the basis of their fuel demand to balance the biogas production with the energy demand.

1.3 Specific objectives

- ✓ Assess Energy usage trends, sources of Household energy consumption and amounts of consumption rate of selected households of Holeta.
- ✓ Identifying the average amount fuel demand of the selected households per day, per month and also annually
- ✓ Identifying a Biogas production potential of the households, digester needed for a corresponding energy demand of households using Spreadsheet modeling.
- ✓ To identify Economical advantages from Biogas technology.

1.4 Significance of the study

This study will help in the planning of a Biogas system design. The Biogas system modeling enables any user to plan a Biogas plant design based on energy consumption of household fuels. The spreadsheet Modelhelp users in forecasting the Biogas production potential of the Household and also the current energy demand of households based in Biogas amount. Since the approach is very easy and it will help the rural households, especially those who own the cattle livestock farm to turn their face to a cleaner Energy technology. This will be done using the easily accessible cattle waste. Through these resources, rural holds will be able not only to meet energy demand but also they will contribute to minimize environmental contamination. In addition to that costs spent for fertilizers will be minimized.

1.5 Scope and limitations of the study

This research includes a study of the traditional fuel usage trend, the impact and development history biogas technology and different types of biogas plants from different literatures. This study will assess and identify the fuel demand and Energy usage trend of selected households. It also quantifies the present energy demand and

calculations have been done to change the corresponding amount in a biogas amount which can satisfy the demand. The spreadsheet model is also prepared to help the planning of the biogas plant design. This will help the any computer literate person to easily forecast basic Biogas plant parameters for the design purpose.

The demand and the intended amount of biogas production system design have been done based on different literature values in a way to Balance the energy demand of rural household with the biogas production. The spreadsheet modeling is also created to help the design. Calculations of each value in model will be crosschecked with manual calculation to check the effectiveness of the Model. This research will have a design calculation part for the digester and gas holder of a Biogas production plant for rural cattle owner households based on their fuel demand. The study also tried to observe the economic advantage of using biogas technology in a way to satisfy most of rural households fuel demand.

The study will mostly focus only on family size biogas plant design but it does not include Families who do not own cattle. This research does not study the factors which affect the production process and also the amount and nature of the animal waste produced in different parts of the country. It will not also study the effect and the nature of the animal wasteand biogas usage other than cooking and heating purposes.

The Limitations are

- ✓ financial constraints
- ✓ Data limitations
- ✓ Community acceptance issues and poor ownership responsibility by users

CHAPTER TWO: LITRATURE REVIEW

2. Types of Biomass Fuels

Biomass fuels are organic materials produced in a renewable manner. Two categories of biomass fuels, woody fuels and animal wastes, comprise the vast majority of available biomass fuels. Municipal solid waste (MSW) is also a source of biomass fuel. Biomass fuels have low energy densities compared to fossil fuels. In other words, a significantly larger volume of biomass fuel is required to generate the same energy as a smaller volume of fossil fuel. The biomass is mainly obtained from firewood, charcoal, dung and crop residues that mainly depend on the surrounding forest resources and agricultural residues. In consequences, the country's forest and land resources is being depleted and degrade with an alarming rate, resulting in desertification, reduction in agricultural production and recurrent drought, increase Emission of greenhouse gases. (Nadew Tadele, 2014).

If we look the change in forest cover, between 1990 and 2000, Ethiopia lost an average 140,900 hectares of forest per year with an average annual deforestation rate of 0.93%. In total, between 1990 and 2005, Ethiopia lost 14.0% of its forest cover, or around 2,114,000 hectares. On the other side, Ethiopia imports its entire petroleum fuel requirement by spending over 80% of the foreign earnings annually. The demand for petroleum fuel is increasing rapidly due to a growing economy and expanding infrastructure. Hence, it is very critical to look for alternative energy sources in order to contribute for solving economic, environmental and social problems. Availability of the bio-fuel feedstock locally and its potential benefit for rural community in employment creation and modern life style is the very big advantage. Potential alternative energy with all ranges of thermal application therefore, bio-fuel development as one of the packages in Energy development promoting wide scale development of renewable and energy efficiency and conservation is given high regard. Rural areas have been used as territories to generate energy for centuries; Coal mines through nuclear power stations to growing bio-fuels and building large-scale wind farms. However, people living in rural areas very rarely benefited from hosting this essential infrastructure. (B kofler, 2014)

Traditional cooking practices in Ethiopia have not only significantly contributed to Ethiopia's deforestation problem, but have also become a major public health issue. According to World Health Organization, Ethiopia is among the countries worst affected with a national burden of health due to indoor air pollution (WHO, 2004). Premature deaths are occurring due to acute lower respiratory infections (ALRI) amongst children younger than 5 years of age, while adults suffer and die from chronic obstructive pulmonary disease (COPD) and lung cancer

2.1 Rural households' Traditional Energy Utilization

2.1.1 Household Energy Use

Ethiopia is the third largest user in the world of traditional fuels for household energy use, most the population dependent on traditional biomass (e.g., fuel wood and dung) to meet their energy needs; (Jargstorf, 2004). As reported by the Ethiopian Rural Energy Development and Promotion Center (1998), in 1996, the most recent year for which statistics on the energy sector are available, 77% of total final energy consumption consisted of firewood and charcoal while another 15.5% consisted of agricultural residues; only roughly 6% was met by modern energy sources such as petroleum and electricity, and only 1% of the population utilized electricity for cooking. Of total energy demand, approximately 89% was consumed by households, while a mere 4.6% was due to industry. These patterns are expected to continue, with overall energy demand forecast to grow between 2001 and 2010 by 3%, with growth over these same years being 2.6% for biomass, 7.9% for electricity, and 8.7% for petroleum. While Ethiopian demand for modern energy sources is expected to grow faster than for any other energy source, biomass fuels will continue to dominate total energy consumption, the effects of which, discussed in detail below, are not without harmful consequence. Given the presence of rapid urbanization, however, these household energy patterns can be expected to shift considerably in the coming years. To see how, consider first differences in fuel use between rural and urban inhabitants. In rural areas, nearly 85% of the population depends on fuel wood as their primary fuel for cooking, with the next largest primary dependency ratio being 12.65% for crop residue; only 0.21% of the rural population depends on kerosene for their primary cooking fuel, while the numbers for electricity and LPG are 0.05 and 0.07%, respectively. Contrast this to the capital city of Addis Ababa, where 42% of residents depend on kerosene as their primary fuel, compared to just 6.5%, each,

for LPG and electricity; approximately one quarter of the population in Addis Ababa depends on fuelwood for their primary fuel, with 8% depending on crop residue and 4.5% depending on charcoal. (Ethiopian Central Statistical Authority, 2004)

When all fuels used are considered, over 90% of the population in Addis Ababa depends on kerosene; although no official statistics are available on all fuels used by households in rural areas, the percentage of households who use kerosene is not likely to vary greatly from those who use it as their primary fuel given kerosene is not widely available in rural areas.

Clearly, then, as rural Ethiopian households migrate to urban centers, which they are doing at a rate of over 4% per year, the energy balance of the country will shift (growth of the capital is rumored to be greater than 6%); overall, fuel wood use will decline as households, in the absence of a suitable alternative, switch to kerosene (World Bank, 2007). This is beneficial in that it mitigates the pressure on fuel wood, but detrimental in that dependency on petroleum imports increases; as dependency on petroleum imports increases, so, too, will expenditures of valuable foreign exchange.

The rural population of Ethiopia entirely depends on biomass for everyday energy needs except for light. The traditional system, particularly during cooking, incurs among others huge energy loss that could have been used otherwise. The system has been recognized as having significant effect on natural resource degradation, harmful health hazards and negative economic consequences.

The use of wood as fuel source for heating and cooking is as old as civilization itself. Almost all African countries still rely on wood to meet basic energy need. Wood fuels account for 90-98% of residential energy consumption in most sub-Saharan Africa. Ethiopia consumed 0.566 million m³ of wood accounting for 9.1% of total African cooking and heating wood consumption. Fuel wood accounts for around 78% of the total energy demand in Ethiopia. In general, average energy consumption of African households is significant. The average per capita firewood consumption in some African countries for families of 2-6 members was estimated at 1.14-1.36 tons. Families with seven and greater members consume on average 1.12 tons per capita with the annual total consumption for an average family of 4.7 persons being 6.4 tons.

2.1.2 Local Energy Consumption and Sources

Biomass fuels (firewood, agricultural residues, animal wastes and charcoal) account for up to 90 percent of the energy supply of Ethiopia.

The average annual tree based wood consumed was 0.34 tons on adult equivalent and 0.32 tons on per capita bases. In Dega and moist Woina Dega agro-ecological zones of Ethiopia, the annual per capita fuel wood consumption is estimated to be 609 kg and 882 kg respectively (Biomass Energy strategy Ethiopia, 2013).

2.1.2.1 Source of fuel wood

Fuel wood has been used as source of energy for most of the rural households in combination with animal dung. Homestead eucalyptus plantation was the major (56.6%) source. Trees in the farm land provide part of the demand. In other studies, approximately 48% of the households collect fuel wood from common areas (Biomass Energy strategy Ethiopia, 2013)

2.2 Disadvantages of Traditional Energy Utilization System

Energy utilization in the developing world is a major threat to the environment and health aspects occurring in the rural and poor urban households. Lack of clean and affordable energy is recognized as a significant barrier to development and major contributor to a host of environmental and human health problems (Dagninet Amare, 2014) Reliance on traditional energy sources of biomass brought threat from overuse, creating additional environmental challenges ranging from local land use to global climate change and applications in smoky kitchens (Saidi T, 2005). If current fuel wood utilization trends continue, most developing countries are predicted to experience severe shortage of fuel wood by 2025.

2.2.1 Defect of traditional system

Given the available traditional energy utilization system, there is extravagancy in energy utilization. High biomass energy consumption along with inefficient utilization has contributed for deforestation, biodiversity loss and land degradation. In Ethiopia the common and dominant energy system is the open stove system. This system has been described as having several defects. For example much of the energy is lost without purposes due to its openness and wind condition. Women are exposed for

dual health problems. At first the smoke coming from the stove does not have a specific direction, it moves all ways resulting in open exposure of the women for the smoke heat (Peter Sutcliffe, 2013). It is not uncommon to see significant population of the rural women with leaking eyes. Moreover the heat coming from the stove does hurt the front leg of the women. It is also common to see darkened and dry front legs of women. The family is also in danger of the health effect as most are done inside or around the house where baby children are also victims of this technology. Thus, the traditional energy production system for baking and cooking is a basic economical and health issue problem at the household level (Saidi T, 2005)

2.3 Renewable Energy

The term renewable energy resources mean that energy produces from the sustainable resources. The most renewable energy resources used are biomass, geothermal, wind and solar energy. As conventional energy resources are going to decline, we should think about on renewable energy resources. For energy, the world depends on the fossil fuels such as oil, gas and coal. The population of world's stabilization will need the increase use of fuel as oil and gas resultantly these resources will be depleted in near future. The utilization of renewable energy resources will be beneficial for this world. This utilization of renewable energy resources will fulfill our energy requirement and also have no effect on our environment. These are eco-friendly resources (Eugene D. Coyle, 2014)

The shortfall of fuel and electricity in Ethiopia is an indication for us to decrease our dependence on conventional fuel resources and find the new sustainable resources such as renewable resources has proved potential for renewable energy resources such as wind, solar and bio-fuels. Utilization of these renewable energy resources could save our foreign reserves and also create new employment opportunities.

2.4 Biogas

Among the renewable energy resources, biogas is one of big renewable energy resource. World in general and Europe is specially working on this kind of renewable energy resource. Energy can be produced by biogas for various applications and thus raise the living standard of people.

Biogas can be produced from different feed stocks in which mainly are municipal solid waste, animals manure, distillery spent, kitchen waste and dairy manure. Biogas gas is produced by the conversion of green waste by a process called anaerobic digestion. During anaerobic digestion, microorganism transform organic matter contained in the wastes into biogas the produced biogas can be used either directly for cooking, heating or lightening or be transformed into combined heat and power (CHP) in small cogeneration plants.

With time the reactors fill up and digested sludge (sludge which organic fraction was already converted to biogas) accumulates in the bottom. Nutrients remain in the sludge, which is a well-balanced soil amendment. Toilets can be linked to the reactors and co-digested with the animal dung, but biogas production from human manure is only low and therefore animal dung and green wastes are required to cover a family's needs. Small-scale anaerobic biogas reactors are very common in agricultural regions in industrialised as well as developing countries.

The valuable component of Biogas is methane (CH_4) which typically makes up 60%, with the balance being carbon dioxide (CO_2) and small percentages of other gases. The proportion of methane depends on the feedstock and the efficiency of the process, with the range for methane content being 40% to 70%. Biogas is saturated and contains H_2S , and the simplest use is in a boiler to produce hot water or steam. The most common use is where the biogas fuels an internal combustion gas engine in a Combined Heat and Power (CHP) unit to produce electricity and heat. In Sweden the compressed gas is used as a vehicle fuel and there are a number of biogas filling stations for cars and buses. The gas can also be upgraded and used in gas supply networks. The use of biogas in solid oxide fuel cells is being researched.

Energy benefits

- Provides cooking and heating fuel (stoves and burners 55 % efficient)
- We can advance the technology and use biogas as a Lighting fuel (biogas lamps with mantles)

Environmental and social benefits

- Significantly reduce carbon dioxide emission and reduces fuel wood pressure which is seen in the rural areas of the country. This will lead us to have healthy and sustainably developed society.
- Biogas is a clean source of energy (no smoke and soot during combustion); so those people using this technology especially women and children will not suffer with the health problems due to the smoke of the old and traditional wood fuel and Charcoal. It helps also to produce a pathogen free nutrient rich fertilizer.(IFAD, 2011)

Economic benefits

- Cheaper source of cooking energy
For most Ethiopians in the rural areas, livestock farming is common by the side of plant farming and in addition to this some areas the agriculture is owned by livestock farming mainly. Since the wide range of livestock availability becomes a sufficient amount of Animal dung potential, the animal dung cakebe used to benefit the society by starting from the household level. (IFAD, 2011)
- The other thing which is not minor to mention is a potential for Jobs to be created (builders and technicians).

Make up of Biogas

The typical biogas components which are contained in its gaseous mixture are those that make it capable of producing renewable Energy. During **anaerobic digestion** of organic materials which contain certain groups of anaerobic **bacteria**, the organic substrate is converted into **biogas**, a gaseous combustible mixture, which has the ability to be used in various applications for **energy production**. The main compound consisted in biogas mixture is **methane (CH₄)** which is actually the compound that gives biogas combustible properties. Methane is easily burned according to the following well-known exothermic combustion equation: (Peter Jacob, 2009).

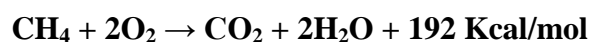

The complete combustion of 1m^3 of CH_4 provides about 8.570 kcal of heat. Thereby, biogas can be used in the following applications:

- Direct combustion in a boiler for heat production
- Utilization, after the proper pretreatment, in internal combustion engines for electric energy production (or both heat and electricity if a cogeneration engine is used).
- Upgrading into bio methane so as to be used as a transportation fuel. Alternatively, upgraded biomethane can substitute natural gas (a non-renewable fuel), at its various applications in chemical industry.

Apart from methane, biogas contains significant amounts of carbon dioxide (CO_2), which is non-combustible, along with smaller quantities and traces of other compounds. A typical composition of biogas can be seen on the following table: (Peter Jacob,2009)

Table 1. Make up of Biogas

Component	Formula	Concentration (% by vol.)
Methane	CH_4	55-70
Carbon dioxide	CO_2	30-45
Nitrogen	N_2	0-5
Oxygen	O_2	<1
Hydrocarbons	$\text{C}_n\text{H}_{2n+2}$	<1
Hydrogen sulfide	H_2S	0-0.5
Ammonia	NH_3	0-0.05
Water (vapour)	H_2O	1-5
Siloxanes	$\text{C}_n\text{H}_{2n+1}\text{SiO}$	0-50 mg/m

Source: <http://www.bioenergynet.com>

WHAT ARE THE FEED STOCKS OF BIOGAS?

The material that is used in anaerobic digestion is called feedstock. What goes into a digester determines what comes out, so careful choice of feedstock is essential. Securing a reliable feedstock supply is fundamental to profitable AD and if feed stocks are to be bought from an third party securing a long-term contract on acceptable terms is critical.

The feedstock doesn't have to be waste, any biodegradable non-woody plant or animal matter is a suitable feedstock for a digester. However, anaerobic micro-organisms cannot

break down lignin, the complex polymer that gives plants their strength, which means that wood products, paper and straw will slow the digester.

The yield of biogas from a particular feedstock will vary according to the following criteria. (Sources: <http://www.biogas-info.co.uk/about/feedstocks/>)

- Dry matter content
- The energy left in the feedstock, if it has undergone prolonged storage it may already have begun to break down
- Length of time in the digester
- The type of AD plant and the conditions in the digester
- The purity of the feedstock:

2.5 Anaerobic digestion

Anaerobic digestion is the natural biological process which stabilizes organic waste in the absence of air and transforms it into bio fertiliser and biogas. It is a 4-stage process: hydrolysis, acidification, acetogenesis and methanogenesis. (Laurel Erika Rowse, 2011). In the first phase anaerobic bacteria use enzymes to decompose high molecular organic substances such as proteins, carbohydrates, cellulose and fats into low molecular compounds. During the second phase acid forming bacteria continue the decomposition process into organic acids, carbon dioxide, hydrogen sulphide and ammonia. Acid bacteria form acetate, carbon dioxide and hydrogen during the acetogenesis phase. The methanogenesis phase involves methane forming bacteria producing methane, carbon dioxide and alkaline water. The process of anaerobic digestion takes place in the intestines of humans and animals and in a landfill site, the latter in an uncontrolled manner. Anaerobic digestion has been widely used in Germany, Sweden, Austria and Denmark and the technology is well proven and established. (Laurel Erika Rowse, 2011). There are two types of anaerobic digestion. They are Mesophilic Digestion and thermophilic digestion. In Mesophilic Digestion the digester is heated to 30 - 35°C and the feedstock remains in the digester typically for 15-30 days. Mesophilic digestion tends to be more robust and tolerant than the thermophilic process but gas production is less, larger digestion tanks are required and, if sanitation are required, are a separate process stage. In the thermophilic Digestion the digester is heated to 55°C and the residence time is typically 12-14 days. (Peter Stuart, 2015). Thermophilic digestion

systems offer higher methane production, faster throughput, better pathogen and virus ‘kill’, but require more expensive technology, greater energy input and a higher degree of operation and monitoring. During this process 30-60% of the digestible solids are converted into biogas. Mesophilic digestion is the most common approach since it is more reliable and plant management is easier. (Peter Stuart, 2015)

2.6 Spread sheet modeling as a Design planning tool

Models are used every day to aid in the decision-making process. Models can help executives make strategic decisions about acquisitions and expansions. They can also help clarify tactical decisions such as production and employee scheduling, route planning for vehicles, and product mixes. Sometimes models are embedded in complex information systems, and other times they are simpler and implemented separately. (Suppa, 2010)

Former work has been done in University of south Florida on the title “Designing small scale anaerobic digester for Application in developing countries”. A Microsoft Excel spreadsheet was developed to be used as a design tool for computer literate individuals with little engineering knowledge to size anaerobic digesters in rural developing countries. (Laurel Erika Rowse, 2011)

2.6.1 Spread sheet models as a decision-making tool.

A number of different types of models exist. The most common are

- ✓ **Mental models** are which we “build” in our heads and use to make decisions. The traffic-light situation calls for a mental model.
- ✓ **Visual models** use graphics or diagrams to represent real objects or situations. For example, a road atlas represents a system of roads and other key land features.
- ✓ **Physical models** involve objects that represent other objects, such as an architect’s scale model of a new building.
- ✓ **Mathematical models** use equations and relationships among quantities to represent situations.

Spreadsheet models are a means of implementing mathematical models. Although there are a number of different model types, commonalities exist among them. First, the use of models is motivated by a decision that needs to be made. Second, All models rely on inputs. Inputs are quantities or factors that affect the situation. Inputs can be controllable or uncontrollable. (Suppa, 2010)

2.7 The history of biogas production

Biogas offers an attractive option to replace unsustainable utilization of wood and charcoal. It complies with the principles put forward in the country's Energy Policy and Environmental Protection Strategy, and closely meets the terms of the Plan for accelerated and Sustained Development to End Poverty (PASDEP) as well: it is a local, renewable resource that addresses the basic needs of rural households amongst which energy; it supports decentralized access to household energy; it's by-product – bio-slurry enhances agricultural productivity and promotes organic farming, thus offering opportunities for niche markets and export. On the whole, it ensures environmental sustainability and its use as domestic fuel improves development conditions and opportunities for women and girls. (National Biogas Program, Ethiopia)

Biogas technology was introduced in Ethiopia as early as 1979, when the first batch type digester was constructed at the Ambo Agricultural College. In the last 25 years, around 1,000 biogas plants were constructed in households, communities, and governmental institutions in various parts of the country. According to documents, around 40 per cent of the biogas plants that were constructed are not operational due to lack of effective management and follow-up; technical problems; loss of interest; reduced animal holdings; evacuation of ownership; and water problems (Boers, *et al.*, 2007).

Due to the renewed interest in biogas, and in order to unleash the potential for this bio-fuel in Ethiopia, a feasibility study was commissioned to assess the prospects for domestic biogas in the country. This study led to a formal partnership between the Ethiopian Rural Energy Promotion and Development Centre (EREDPC) and SNV/Ethiopia, and in 2007 a joint EREDPC/SNV team was established to develop a programme implementation document. An extensive stakeholders' consultation process

at both regional and national level resulted in more than 120 representatives of the government, non-governmental organizations, and the private and financial sectors gaining awareness about the features and functions required for a national biogas programme (NBP), and providing ample inputs for the development of the programme. The NBP envisages a first – pilot – implementation phase with construction of 14,000 biogas plants in four regions and development of a commercially viable biogas sector in the country. The lessons learnt from this phase will be used to design strategies for up scaling the construction of biogas plants covering more areas. (National Biogas Program, Ethiopia)

People have known of the existence of naturally produced biogas since the 17th century and experiments with the construction of actual biogas systems and plants started as early as the mid-19th century. One of the oldest biogas systems is the septic tank, which has been used for the treatment of wastewater since the end of the 19th century and is still used for isolated properties where there is no sewerage system. In this type of plant the biogas is, however, not collected and used. In the 1890s, the Englishman Donald Cameron constructed a special septic tank, from which the gas was collected and used for street lighting. In Denmark the construction of biogas plants for wastewater treatment started in the 1920s. The gas was initially used to heat the plant's digester tank and the main purpose was therefore not to extract energy, but to decompose organic matter in the wastewater and thus reduce and stabilize the sludge, which is a product of the treatment process. In the following period and until shortly after the Second World War, there was a substantial growth in the biogas industry, particularly in Germany, Britain and France.

2.7.1 Different Types of AD of Animal Wastes in USA

Due to energy prices rising, broader regulatory requirements and increased competition in the market, American agriculture's livestock sector has considered AD of animal wastes. There are several types of AD used widely in America. Here are different types of AD (Balsam, 2006).

Covered lagoons

It is a pool of liquid manure topped by a pontoon or other floating cover, and there are seal plates extended down the sides of the pontoon into the liquid to prevent exposure of the accumulated gas out of the atmosphere. Because this type of digester only uses

manure with up to two percent solid content, it requires high throughput for the bacteria which is able to work on enough solid to produce gas. Covered lagoons are usually used in warmer southern regions, where the warm weather can help maintain the digester temperatures. The size of covered lagoon digesters is usually large and retention time is long (30-45 days or longer). This type is the least expensive of all digesters to install and operate. And roughly 18% of all digesters used in the U.S.A nowadays are covered lagoon system (Balsam, 2006).

Complete mix

It is a silo-like tank which could handle manure with between two and ten percent solids and the manure in it could be heated and mixed. The retention time of complete mix digester is usually 10 to 20 days. (Source: <http://www.biogas.psu.edu>).

This type of digesters is the most expensive system to install and operate. And 28% of all digesters used in the U.S.A nowadays are complete mix system (Balsam, 2006).

Fixed film

It is a tank filled with a plastic medium which supports a thin film of bacteria named a bio-film. This system could handle one to two percent solids, and requires a shorter retention time (two to six days). Fixed film digesters have small reactor and must be loaded with a feedstock that could flow through the medium without clogging. Only about one percent of all digesters currently used in the U.S.A are fixed film system (Balsam, 2006).

2.7.2 Different Types of Biogas Plant in Europe

In Europe the first biogas plants were developed and constructed to remove the odor of animal waste as well as to provide electric energy and heat to farms. Along with the development of biogas technology, today more biogas plants are installed to produce the electricity or generated other energy forms for sale. There are many types of biogas plants in Europe. They can be categorized as the type of digested substrates, the technology used or their size, etc. However, the agricultural biogas plants usually are classified as two categories: the large scale, joint co-digestion plants and the farm scale plants (Holm-Nielsen et al., 2009). There is no big difference between these two categories in technologies. And the technologies are applied in one category are common to the other.

2.8 Digester Technology

In Europe most of biogas digesters are made of concrete with a steel skeleton or of steel (Plochl and Heiermann, 2006). They usually have a cylindrical form standing upright. The digester tanks are equipped with insulations and heating systems in order to control temperature conditions inside. They are also equipped with systems to agitate or to stir the slurry. The biogas is collected in an external plastic bag or in the space above the slurry covered with a foil (Plochl and Heiermann, 2006). The average retention time is usually about 28 days (Plochl and Heiermann, 2006). However, it could increase to 90 days if crops or crops residues are added (Plochl and Heiermann, 2006). So a lot of biogas plants work with a post digester or a slurry storage tank covered with a foil as gas storage space.

The input materials are added to the premixing pit; the feedstock is pumped from the premixing pit into the digester tank; the slurry in the tank is agitated by pressurized biogas; then digested slurry is pumped out for post digesting or storage (Plochl and Heiermann, 2006). Besides wet AD technology mentioned above, dry AD technology is also used in Europe. The wet technology works with slurry of less than 12% dry matter content, while dry technology usually works with slurry of more than 30% dry matter content (Plochl and Heiermann, 2006). Therefore, dry AD process could handle mainly crops and crop residues as feedstock.

2.8.1 The joint co-digestion biogas plants

These plants co-digest animal manure from a number of farms, with suitable organic residues from the food and feed industries. The joint biogas plants have the digester capacities from few hundred m³ up to several thousand m³. Denmark is one of the pioneer countries to develop agricultural biogas plants for manure and organic residues co-digestion, which developed the joint biogas plant concept over the last two decades and represents an integrated system of manure and organic waste treatment, nutrient recycling and renewable energy production, generating combined agricultural with environmental benefits (Holm-Nielsen et al., 2009). Fresh animal manure and slurry need to be collected from the pre-storage tanks at the farms, transported to the biogas plant then mixed and co-digested with suitable organic wastes. In order to inactivate pathogens and to break their propagation cycles, specific substrates and animal by-products need to be submitted to a controlled pre-sanitation before entering the reactor content. The digested biomass is transferred to the storage tanks, usually covered with a gas proof

membrane in order to recover the remaining biogas production (Holm-Nielsen et al., 2009). When the digested biomass is transported back to the farms, it is free of pathogen and nutritionally defined as liquid fertilizer and integrated in the crop fertilizer plan at each farm. Actually, the farms only receive back the digested biomass which allowed by the law to use on their fields, based on the regulation on nutrient loading per ha (Holm-Nielsen et al., 2009). The biogas plant sells the excess of digested biomass to the crop farms.

2.8.2 The farm scale biogas plants

These plants co-digest animal manure and slurry from one single farm, or only two or three smaller neighboring farms (Holm-Nielsen et al., 2009). The applied technology in the farm scale plants is similar to the joint biogas plants. Pre-treatment, post-treatment and separation technologies are also applied in the farm scale biogas plants. In Denmark, there are two types of farm scale plants implemented. The first type is named the Smedemester (Blacksmith) biogas plant (Raven and Gregersen, 2007). Due to local testing and experimenting as well as supports from the German biogas industry, the Folkecenter has developed two standardized Blacksmith plants. The first plant is a horizontal steel tank, with the size between 50 and 300 m³ (Raven and Gregersen, 2007). The manure takes 15-25 days transporting from one side where it is added to the other side of the tank by a horizontal stirrer (Raven and Gregersen, 2007). The second Blacksmith plant type is a vertical tank, with the size from 400 m³ and upwards (Raven and Gregersen, 2007). A second type of farm scale biogas plants was developed by the Bigadan Company during the 1970s and 1980s, which consisted of low concrete digesters. During 1990s, based on conventional slurry storage tanks covered with membranes, some new concepts were developed (Raven and Gregersen, 2007). One of these plants is the Soft Cover Plant, which has a small concrete digester inside a storage tank. When the digester is full, the manure will overflow into the storage tank.

manure is added from the animal shed into the process-tank; then digested manure overflows into the process storage tank; an external storage tank provides the extra storage; when Biogas is produced from the digestion process, it will be transported to a CHP unit for the production of power and heat; the power is fed back into the grid while the heat could be used for maintaining the digester temperature and heating the animal shed (Raven and Gregersen, 2007).

2.8.3 Biogas in developing countries

A number of developing countries use biogas extensively. In India and China alone, there are more than one million small, simple plants, each treating waste (sewage, animal manure, crop residues, etc.) from a single household. The plants are dug into the ground and are unheated. The biogas is used in the housekeeping for cooking and the digested biomass is used as a fertilizer. Technologies which recover biogas do so by harnessing anaerobic degradation pathways controlled by a suite of microorganisms. Various appliances can be fuelled by biogas, with stoves offering an application appropriate for deployment in developing countries. Widespread dissemination of biogas digesters in developing countries stems from the 1970s and there are now around four and 27 million biogas plants in India and China respectively. These are typically small systems in rural areas fed by animal manure. However, in many other countries technology spread has foundered and/or up to 50% of plants are non-functional. This is linked to inadequate emphasis on maintenance and repair of existing facilities. Hence for biogas recovery technology to thrive in the future, operational support networks need to be established. There appear to be opportunities for biogas stoves to contribute to projects introducing cleaner cook stoves, such as the Global Alliance for Clean Cook stoves. Beyond this, there remains potential for domestic plants to utilize currently underexploited biogas substrates such as kitchen waste, weeds and crop residues. Thus there is a need for research into reactors and processes which enable efficient anaerobic biodegradation of these resources.

2.8.4 Different types of biogas plants

Plug flow digesters

This is a type of anaerobic digester that uses a long, narrow horizontal tank in which a material (manure) is added at a constant rate and that force other material to move through the tank and be digested. Typically, a plug flow digester vessel is five times longer than it is wide, is insulated and Heated, and is made or reinforced concrete, steel or fiber glass. Plug flow digester has no means of agitation. The term "**plug flow**" derives from the fact that the manure in principle flows through the digester vessel as a "plug," gradually being pushed toward the outlet as new material is added. In fact, the

Situation is more complicated and some parts of the manure travel faster than others on their way through the vessel, or may even settle or float and remain in the digester (Encyclopedia-of-Alternative-Energy).

The first documented use of this type of design was in South Africa in 1957 (Singh, J. B, 1987). The main advantage of the plug-flow design is that it is simple and economical to install and operate. However, it is not as efficient or as consistent as the completely mixed design. Plug-flow units are limited to applications with low amounts of sand, dirt, or grit, because these substances will tend to stratify and settle out inside the digester, requiring significant effort to clean out. Complete mix units are more expensive to install and operate than plug flow units, because they require both the capital equipment and the energy for mixing (Source: www.extension.org)

Fixed dome digesters

A well and a dome are made out of cement concrete. Fixed dome Chinese model biogas plant (also called drum less digester) was built in China as early as 1936. Fixed dome digesters are usually built underground. The dome is fixed and hence the name given to this type of plant is fixed dome type of biogas plant. The function of the modified fixed dome digester plant is similar to the floating holder type biogas plant. The only difference is the fixed top part of the digester. The used slurry expands and overflows into the overflow tank. Disadvantages of fixed dome digesters are that special sealants are required, high technical skills are required for construction, and gas pressures fluctuate, which causes complication of gas use (Biogas SA, 2014).

The difference between Fixed dome and Floating drum digesters is that, in Fixed dome digester the upper part of the digester is fixed, i.e., it does not experience any movement on the upper side when the gas starts to fill up the available empty space as compared to the floating tank type digester.

Floating drum digesters

Patel's became popular in the world. It is divided into two parts. One side has the inlet, from where slurry is fed to the tank. The tank has a cylindrical dome made of stainless steel that floats on the slurry and collects the gas generated. Hence the name given to this type of plant is floating gas holder type of biogas plant. The slurry is made to ferment for about 50 days. More gas is made by the bacterial fermentation, leading to the pressure inside the gas collecting dome to increase. The gas can be taken out through an outlet

pipe. The decomposed matter expands and overflows into the next small holding tank (Cheng, J. and B. Liu. 2002). The shortcomings of these digesters discussed above is that the pressure cannot be manipulated or maintained to a specific value for a certain period of time in order to observe the effect it has on the composition of the gas and on the activity of the bacteria.

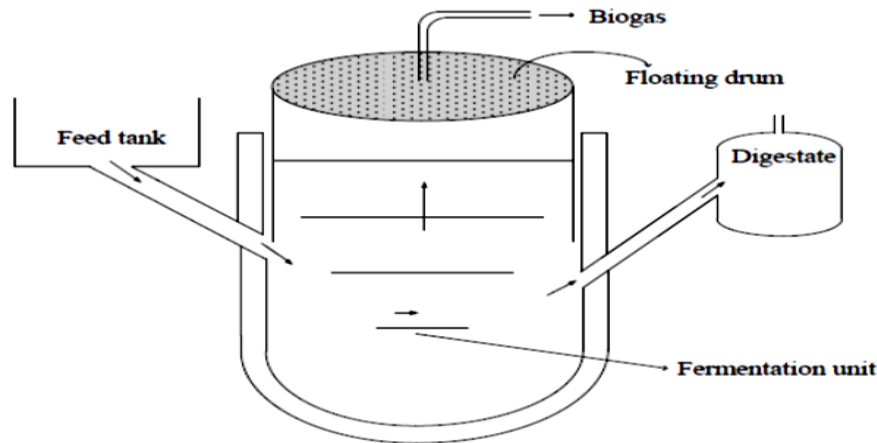

Figure1. Floating Drum digester

BIO-GAS POTENTIAL AS A SUBSTITUTE FUEL

The (thermal) energy available from the methane contained in biogas is about 6 to 8 kWh/m³. This corresponds to half a liter of diesel oil and 5.5 kg of firewood. Gas demand can be defined on the basis of energy previously consumed. For example, for a family having previously consumed 1 kg firewood, this roughly corresponds to 200 L biogas, 1 kg dried cow dung corresponds to 100 L biogas and 1 kg charcoal corresponds to 500 L biogas. 1 kg of human faeces generates about 50 liters of biogas, 1 kg of cattle dung delivers 40 liters of biogas, and 1 kg of chicken droppings generates about 70 liters of biogas (NWP 2006). Gas consumption for cooking per person and per meal is between 150 and 300 L biogas. Approximately 30-40 L biogas is required to cook one liters of water, 120-140 L for 0.5 kg rice and 160-190 L for 0.5 kg vegetables. Tests in Nepal and Tanzania have shown that the consumption rate of a household biogas stove is about 300-400 L/h. However, this depends on the stove design and the methane content of the biogas. The following consumption rates in liters per hour (L/h) can be assumed for the use of biogas. (TILLEY et al. (2014)

- household burners: 200-450 L/h
- industrial burners: 1000-3000 L/h

- refrigerator (100 L) depending on outside temperature: 30-75 L/h
- gas lamp, equivalent to a 60 W bulb: 120-150 L/h
- biogas/diesel engine per bhp: 420 L/h
- generation of 1 kWh of electricity with biogas/diesel mixture: 700 L/h
- plastics molding press (15 g, 100 units) with biogas/diesel mixture: 140 L/h

To use the energy of the biogas, biogas appliances, such as gas stoves or gas lamps are required. Both special biogas appliances or pressure-kerosene and LPG (Liquefied Petroleum Gas) equipment are adapted. Compared to other gases, biogas needs less air for combustion. Therefore, conventional gas appliances need to be modified when they are used for biogas combustion (e.g., larger gas jets and burner holes). The distance through which the gas must travel should be minimized since losses and leakages may occur. Drip valves should be installed for the drainage of condensed water, which accumulates at the lowest points of the gas pipe.

CHAPTER THREE: MATERIALS AND METHODS

3.1 Description of the Study Area

Holeta is a place found very near to Addis and the place is a very beautiful and naturally blessed area. Most of the people in Holeta area are involved in farming one way or the other. Holeta Genet (also transliterated Oletta) is a town and separate woreda in central Ethiopia. Located in the Oromia Special Zone Surrounding Finfinne of the Oromia Region, it has a latitude and longitude of 9°3'N 38°30'E and an altitude of 2391 meters above sea level. Like much of Ethiopia, the economy is mainly based on agriculture. The town hosts a research station of the Ethiopian Institute of Agricultural Research. Founded in 1963, this station is the national center for research to improve the yield of barley, highland oil crops, potatoes, and dairy products

(Source: [http:// www.wikipedia.org](http://www.wikipedia.org))

Holeta's climate is classified as warm and temperate. The summers here have a good deal of rainfall, while the winters have very little. The average annual temperature in Holeta is 15.9 °C. The rainfall here averages 1134 mm. the least amount of rainfall occurs in November. The average in this month is 9 mm. Most of the precipitation here falls in August, averaging 266 mm. www.climate-data.org

From a study on forest degradation risk and landscape disturbance index was made around the Holeta the dynamics and pattern of changes for a period of 33 years (1973-2006). The extent of forest cover decreased at the rate of 546.32 ha yr⁻¹ from 22549.6 ha (22.4%) to 4521 ha (4.49%) and the extent of grassland decreased from 37416.5 ha (37.17%) to 17437.2 ha (17.33%) during the same period.

According to the National Population and Housing Census carried out in 2007, the population of the town was 23,296. Out of this, 11,512 (49.4%) were males and 11,784 (50.58%) were females. Regarding age distribution 6,583 (28%) were within the age group of 0-15 years, 15,581 (66.88%) 16-60 years 1,132 (4.85%) 60 years and above. The population growth rate of the town at medium variant was 4.2% while the average household size in the town is calculated to be 3.3.

3.1 Sample size and sampling procedures

Data collection is done on randomly selected households who own the same range of potential numbers of cattle. This is done to make a consideration for raw material availability. A total number of 35 households were used for the survey. The random selection is done from the list of households who own 10 and more than 10 cattle in the households. Information is collected randomly from different family size that lives in “Geda Jogo” and “Ada odo” Villages which are found in Wolemerawereda. Random selection has been done to incorporate different households with a wider number range of livestock population and different family size. Since Holeta is a place for Agricultural research institute and different farming activities, it has been interesting area to do this thesis.

These villages are selected because of the vast number of livestock population in the area and households involvements in farming activities. Since economic growth due to industrialization and urbanization are influencing a lot on the surrounding of this area, It will be good to emphasize the area has been considered as “rural area” only for the case of this study on the time it is conducted. The researcher has got suitable situations and characteristics rural areas can have in a very near location. These situations helped the study of Biogas system planning for rural households.

The sampling of households are planned to have different family size based on their number of family members. Thirty five households have been assessed in the survey time from the three villages called Rob Gebeya, Geda Jogo and Ada odo. These villages are selected because potential numbers of cattle are found around the area. During the survey information on the present usage trend of the society on energy consumption has been observed and assessed.

3.3 Questions included in the survey

The aim of the survey is to provide the researcher information on energy usage trend of rural households residing in single family dwellings. The survey profiles energy related characteristics of households, identified patterns of behavior related to consumption, amounts and type of energy usage, expenses to collect some fuel items, time spent in collection of some fuels, uses of selected energy consuming equipment and appliances if there is any, the number of cattle the household own and the potential amount of the

cattle dung to be collected has been assessed. The number of family member's and expenses related to fertilizers has been collected in this survey to assess economic issues.

The survey data allows the researcher to determine average household energy demand levels (average energy consumption) and will be used for analysis of the biogas system design which includes the amount of gas to be produced, the size of the digester and the basic plant parameters. This survey is done to help the study of balancing the biogas production (P) with the energy demand (D) and comparison of the technology with the traditional energy usage trend.

3.2 Data collection Methods:

3.2.1 Secondary data

Necessary secondary data for the study were collected from different written sources from different organizations includes Holeta city administration office and Holeta Agricultural research institute which are working on rural households' agricultural development and district agricultural office and district water and energy office.

This secondary data was also gathered from different literatures to help design the biogas system with intended capacity and to study the different ways of advancing this technology. Different scientific methods and parameters are gathered from article and literatures concerning on Bio-gas technology. These literatures include different Books, articles and different researches done formerly on Biogas technology area of study.

Secondary data sources such as published and unpublished documents, journals, and websites that were relevant to the study were reviewed and studied. Moreover, to have a deeper insight about biogas energy benefits and constraints of Holeta district, different organizations were visited and related documents about biogas energy were extensively used.

The secondary data collected mostly on the bases to relate how the Energy demand affect the biogas system design and to find basic correlations of the energy amount which can cover the household energy demand and to study the economic advantages. The secondary data also include general information on the households who are living the field area of study.

3.2.2 Primary data

The research has collected primary data from the field using questionnaire. The researcher has also used different data collection and analysis method to achieve the intended objectives. This primary data is directly found from the target group using a House-to-house survey method on randomly selected households. 35 households are involved for this study. The researcher gathered primary information using questioners and unstructured interview. This information has been gathered by conducting surveys orally and in written form.

The primary data help to study the current situation of the rural households related to energy consumption and the observed trend related to collection, the price and time spent in meeting energy demand. In addition to that this survey assessed the number of cattle owned by each sample households and their family size. Since the researcher wanted to learn the daily activity of the farmer households on a particular focus given to their energy demand; survey has been done on selected areas and households who own a potential number of cattle. This is done with organized questionnaire in a way which can help to observe their energy usage trend. In addition to this survey questions different compiled data from Holeta agricultural institute and from agricultural office of the city administration has been the main sources of the data for this research. This includes the livestock census profile and charts from the office of the study area. Articles and Literatures on related topic have been also used as a source for the required data for this research.

Household data: Household data were collected through semi structured questionnaire. This survey was intended to gather information on demographic characteristics of households (household size, and livestock number), household fuel consumption. The consumption of charcoal, dung cake, fuel wood and kerosene are assessed.

(See: Appendix)

Key informants interview: In addition to the household survey data, the interview was carried out on government and non-government partners and stakeholders who are concerned on biogas energy technology. The key informants were Organization representatives from agricultural office, government officials from the municipality.

Self-observation: The actual conditions, market value of household fuel at the local market (charcoal, fuel wood, kerosene and dung cake), state of waste management.

3.3 Data Analysis Methods

Energy demand of any household is affected by the family number. Finally after compiling the data found during survey on the households, the average family number and cattle number are used in the spreadsheet modeling of biogas system planning based on their average household energy demand and also the observed peak energy demand, the maximum family number and cattle number are also used in the analysis of spreadsheet planning tool. Spreadsheet modeling is used to create a planning tool which is intended to help households' biogas design analysis. Accordingly, the summarized data will be analyzed in brief with the theoretical aspect of the study to arrive at a meaningful conclusion of the Biogas system Design for rural households based on the average and pick energy demand values of the Households. The spreadsheet modeling tool is also intended to help in determining the Biogas demand and the gas production potential of the households. The economical part of the plant design will also be analyzed and the Spread sheet modeling is used to help the forecasting based on the energy demand.

- ✓ The first process is to organize a mathematical relationships, equations and formulas in a way which will help to analyze the energy demand, the gas generating potential, the digester volume and other basic plant parameters.
- ✓ After organizing all the necessary conditions the next step will be preparing the spreadsheet design planning tool. To prepare the spreadsheet design planning tool, first the users input variables and the expected model output variables must be identified and based on the identification the spread sheet calculations will be organized in a way which can give the expected out puts.
- ✓ Finally, functionality of the model will be checked using manual calculations and will be crosschecked with the results found in the spreadsheet tool.

3.5 Energy demand and Bio-gas system Design

After assessing the energy demand of the households the next step was to use the collected and organized data to estimate the Biogas demand. Determining the biogas demand will help in the process of balancing the production of the biogas with the specific biogas demand of the households. The following alternative modes of calculation were used to determine the biogas demand of the households:

➤ **Determining biogas demand on the basis of present energy consumption,**

This involved the direct assessment of the energy consumption of the households. For example for ascertaining the cooking-energy demand involves either measuring or inquiring the present rate of energy consumption in the form of wood, charcoal, kerosene, dung cake and also electricity.

➤ **Calculating biogas demand via comparable-use data:**

Such data may consist of empirical values from neighboring systems, e.g. biogas consumption per person and day, reference data taken from literature, although this approach involves considerable uncertainty, since cooking-energy consumption depends on local cooking and eating habits and can therefore differ substantially from case to case. But for this research assumptions are made based on the cooking trend of the society which this case study is taking place.

➤ **Estimating biogas demand by way of appliance consumption data and assumed periods of use:**

This approach can only work to the extent that the appliances to be used are known in advance, e.g. a biogas lamp with a specific gas consumption of 120 l/h and a planned operating period of 3 h/d, resulting in a gas demand of 360 l/d. Then, the interested party's energy demand should be tabulated in the form of a requirements list. In that connection, it is important to attach relative priority values to the various consumers, e.g.: 1st Priority: applies only when the biogas plant will cover the demand.

2nd Priority: coverage is desirable, since it would promote plant usage.

3rd Priority: excess biogas can be put to these uses.

➤ **Determining the Biomass Supply via Literature Data**

According to this method, the biomass supply can be determined at once on the basis of the livestock inventory. Data concerning how much manure is produced by different species and per live weight of the livestock unit are used.

Dung yield = live weight × number of animals × specific quantity of excrements

[kg/d] Often, specific quantities of excrement are given in % of live weight per day, in the form of moist mass, total solids content or volatile solids content.

➤ **Preparing a spreadsheet modeling tool**

All the calculations and Mathematical relations will be organized in the spreadsheet modeling. This as a result will help to determine the gas generating potential, the Energy demand of the household and the digester volume using the current energy consumptions of the family. The spreadsheet modeling tool will also be used to forecast the economical values the Annual savings, Investment cost, Net present value and Payback period of the project.

The model comprises 2 sheets which consists of different sections

- ✓ Biogas system modeling tool sheet (sheet 1) can be divided in to two categories; the biogas plant design estimation and Economics of Biogas plant.
- ✓ Basic information sheet (Sheet 2). Here different values and equations are involved. Here, basic information which the study used in the biogas plant design, for the economic evaluation is also included. Basic formulas used in the model are also included here.

The purpose of the different cells categories are the following:

Input cells: These cells are in which the user inputs values of energy consumption and specific assumptions about all alternatives that they wish to evaluate. These should be updated each time analysis is performed.

Analysis cells: Shows the outcome of the comparison for the chosen number of alternatives. These cells should never be altered by the user.

Output cells: Use the given assumptions from the Input cells as well as basic data from the Basic information sheets to perform the calculations for each chosen alternative. These cells should never be altered by the user.

CHAPTER 4: DATA ANALYSIS AND PRESENTATION

4.1 Source and uses of energy

Firewood and dung cakes used to bake Injera and bread. Fire wood and dung cake take the largest share in the purpose of cooking (Table 2). The fire wood is either collected from forest or bought from market. 39% of the surveyed families meet their fire wood consumption by buying it from market. Those families who are collecting fire wood from forests travelled an average distance of 5.4 km from their houses and spent 11.5 hr/month to collect it. The charcoal is also either prepared in the house or bought from market. 46% families meet their charcoal need both from market and also by preparing it in house. Since those households which have been surveyed are livestock farmers, it is obvious to have easy access for cow dung. As a result this makes it easy for almost all households to prepare dung cake to meet their cooking fuel need.

Kerosene is used in kerosene lamps to light the houses. Kerosene is used in kerosene lamp for households who do not have access for electricity. Kerosene is also commonly used for lighting purpose during power cuts in the case of households who have access for electricity.

These results show how much the households are dependent on fuel woods and dung cakes. Since households continued using them for the same purpose, the effect that has been observed will cause a lot of damage on the environment and dwellers health. Biomass fuel collection and consumption behavior of rural households with the impact of the usage trend has been studied in Department of Economics, Göteborg University by Alemu Mekonn. Former works has been done on the Status of Traditional Biomass Energy Utilization and its alternative Renewable Energy Technology in the Amhara Region of Ethiopia. (TsigieSimurAsres, 2012)

Kerosene and electricity also incurs a lot of cost on households and kerosene especially has a health effect on inhalation system when it is used for lighting purpose. These as a result need to be substituted with a safe and cleaner energy technology. Recently, it became obvious from the ongoing activities in Ethiopia that future energy demand will boost dramatically due to development of intensives as well as extensive agricultural activities and increased industrial needs. As a result of this household energy sources and

usage trend should be changed to a renewable and cleaner technologies. Among this technology Biogas system is the one who can be suited easily for rural households.

Table 2 Sources of Fuel

Type of fuel	Source	Percent (%)
Charcoal	Bought from Market	31 %
	prepared in the house	23 %
	Bought and prepared	46 %
Fire wood	Bought from Market	31%
	Collected from Forest	69%
Dung	Bought from Market	0%
	Prepared in the house	100%
	Bought and prepared	0%

4.2 Consumption and Price of Energy

4.2.1 Household fuel wood consumption:

The study showed that in the surveyed area all families used fire wood to a larger extent for cooking Injera; Sauce (Wot), porridge and coffee/tea, and they are using dung cake as a supplementary fuel. Average amount of 137.7 kg per month of fire wood is used in every surveyed family. While the maximum amount used is 200 kg and the minimum amount is 90 kg households used the average amount of 1652.4 kg of fuel wood/HH annually.

Major feature of the fuel-wood problem is the strong mismatch between the location of forest resources and the concentration of the population, largely occupying currently deforested land or areas which are being rapidly deforested. Thus, most of the exploitable resource, located in areas with relatively low population density, remains unutilized or is lost in the life cycle process, while over vast expanses of the country; excessive exploitation by the bulk of Ethiopia's population is leading to critical levels of deforestation. Here as we can see from the fuel wood consumption graph (Figure 3) there are households who do not spend money even though they consume more than 100 Kg fire wood in a month. The fire wood is collected from forest instead of getting it from market.

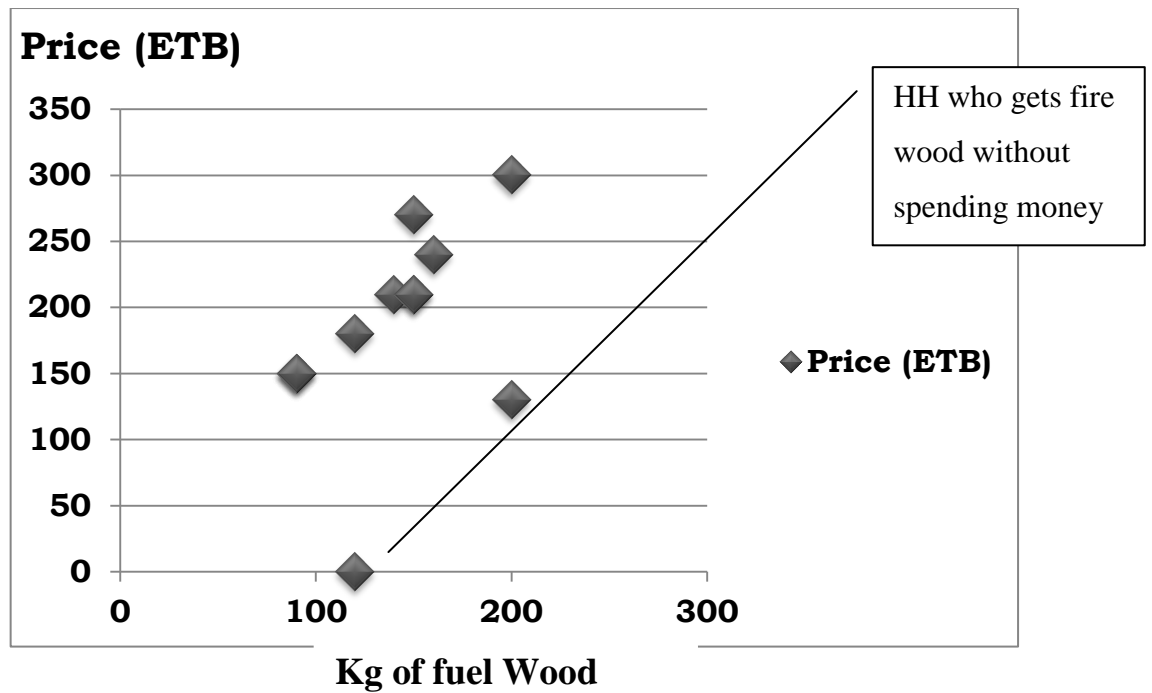

Figure 3. Monthly fire wood consumption

4.2.2 Charcoal consumption

Every household are using charcoal to cook their food and to boil water .The amount of Charcoal used varies from house to house. Most of the households prepare the charcoal by themselves while others get the charcoal from market. Form the survey we can observe the average charcoal consumption in the surveyed household is (62.57 kg) per month and (751.68 kg) per year and the average price spent to get the charcoal is 292.59 ETB per households. Here as we can see from the graph (Figure 4), most households consume a charcoal amount from around 50 Kilogram to 70 Kilogram monthly. Among them most of them didn't spend any cost to use charcoal; only few households buy from market. Since most households collect the fuel wood from forest and from their own land it can easily be used to prepare charcoals.

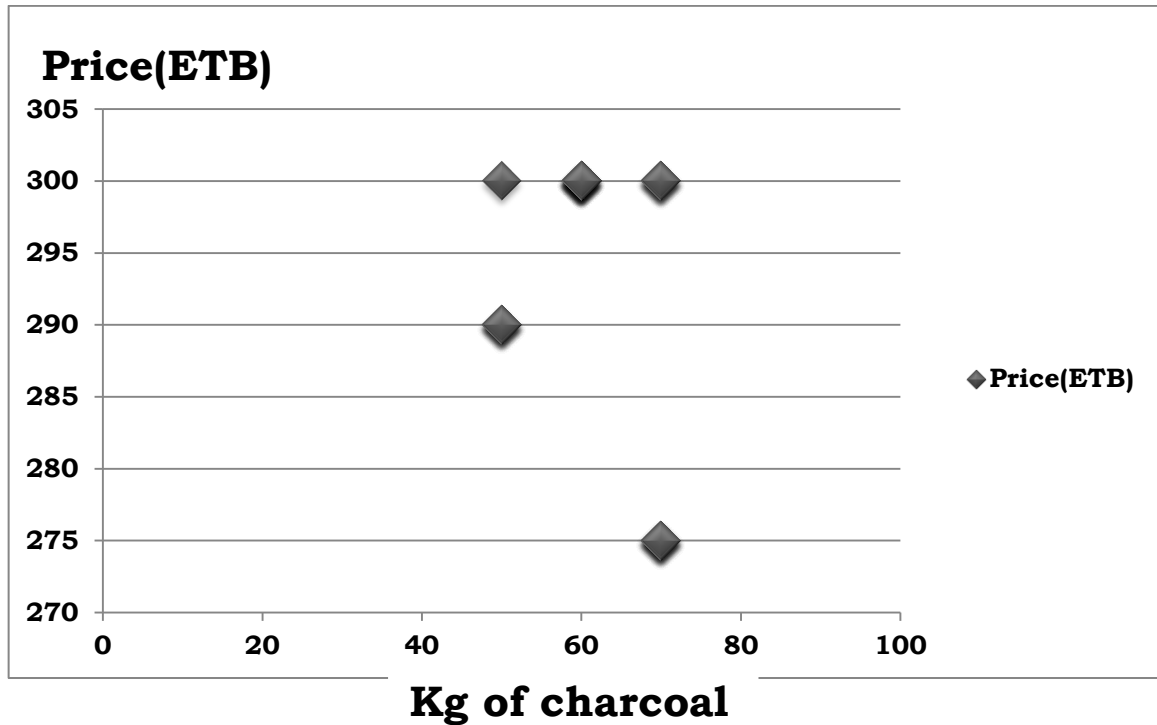

Figure 4 Monthly charcoal consumption and price

4.2.3 Dung cake consumption

The average amount of dung cake used in the surveyed households is with on an average consumption of (184 kg)/HH per month and (2208 kg) used annually. Almost all families use dung cake to bake their breads and they used fire wood as a supplementary fuel to help their consumption of dung cake. The main reason behind the large consumption of dung cake is its access to prepare it easily and without any price.

4.2.4 Kerosene consumption

- The average amount of kerosene used in litter is 2.4375 liters per month
- The average price amount spent to buy the kerosene is 27.708 Birr

4.2.5 Recent trend of Price, Time and distance of Collection

When we observe the recent price trend rural households spent to access energy, the Time spent and distance travelled to collect fuel wood and is increasing continually. The main reason behind is deforestation. The continual decreasing of forest coverage which was found very near of the villages has been a treat for women specially. Because of this Planning to have a cleaner, easily accessible and time saving technology should be given the first priority to plan in removing all this problems.

According to Dejen Kebede and Alemayehu Kiflu's study on Biogas stove for injera baking application, the people in Ethiopia rely on Injera as their primary source of food. Baking Injera accounts for over 50% of all primary energy consumption and over 75% of all household energy consumption. (Alemayehu Kiflu and Dejen Kebede, 2014). Due to the shortage of firewood in growing Ethiopian communities, baking Injera on open fire is becoming increasingly expensive. Women and young children have to walk many miles a day to collect firewood to feed their families. (Alemayehu Kiflu and Dejen Kebede, 2014)

4.3 Electricity

Households who are currently using electricity are mostly using it to light their houses. Very few households own cooking stoves and they are using cooking stoves to cook their watta and to boil water. Even though few households face some challenge on the functionality, some of the households got the chance to use solar lighting systems. Most households are using electricity for lighting purpose. The most frequent number of lamp is 1 and the average lamp number is 1.64 and the average time the lamps give light is 5.7 hr/day.

The three most important rural energy sources, in their order of importance, are fuel wood, dung and Charcoal; while the three most important end uses are injera-baking, other cooking and lighting. The implication of this is that, if rural households are provided biogas technology for lighting and cooking purpose, the gain in terms of environmental protection of rural areas is significant. If the energy diversity is increased by using Biogas technology it will provide a significant role in giving additional help in the process of meeting the energy demand.

Table 3 Electricity consumption

Uses of Electricity	Percent
Lighting only	88%
Cooking and Lighting	12%

Fertilizer in rural households

The price, shortage of supply and late arrival problems are the most frequent factors affecting the decision to use fertilizer and the extent of fertilizer application. However, there are also numerous household specific characteristics that affect the decision to use

fertilizer. Encourage peasants' use of fertilizer from Biogas technology for a sustained increase in yield and the value of production will help them economically to a larger extent. The average amount of annual fertilizer consumption by the peasant households is 220kg. The price of fertilizer is increasing from year to year. In addition to chemical effect of fertilizers on the organic nature of the soil the increasing price trend is the visible headache for the farmer households. Fertilizers which can be gained from the biogas technology not only help the households' finance which could be spent to buy fertilizers but also it will help to keep the natural soil fertility.

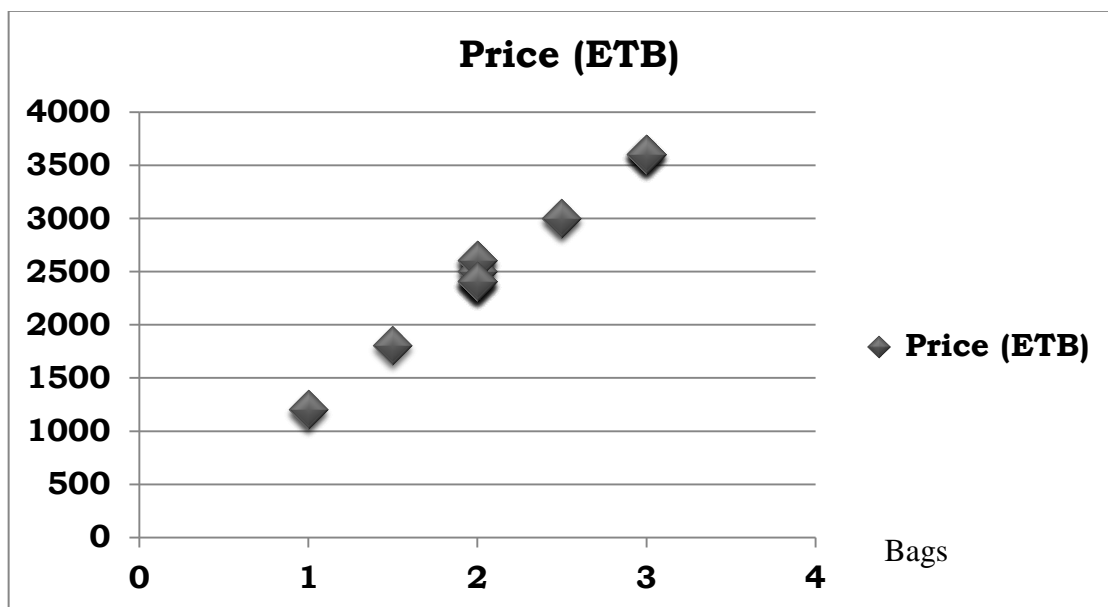

Figure 5. Yearly Fertilizer consumption and Price of Households

Average values

Table 4. Average values

AVEARAGE		AMOUNT
Consumptions	Fuel wood	(137.7 kg) /HH per month
	Dung cake	(184 kg) / HH per month
	Charcoal	(62.57 kg) /HH per month
	Kerosene	(2.4375 liters)/HH per month
Appliances	Lamp	1.64 Lamps 5.7 hr/day
	Cook stove	2
Number of family members		7
Amount of fertilizer for annual use		220kg
Number of cattle		17
Body weight		350 kg

CHAPTER FIVE: BIOGAS SYSTEM DESIGN PLANNING TOOL

Since spreadsheet models are a means of implementing mathematical calculations. It can be used to forecast the final design outputs or parameters based on the Energy demand of the households. When someone plan to design a biogas system, especially which can have a gas generating potential which could be used to meet most of the Energy demand of the household. First the Energy consumption of the household should be converted to biogas amount by making calculations using basic data and then gas production potential of each household should be calculated based on the number of cattle they own. Finally the Digester volume which should be designed for each household will be determined. These calculations will be tedious when it is done manually, especially when we plan to design for a large number of households. Here the spreadsheet model helps this planning stage of Biogas system design. It could be used as a decision making tool. Since it will be easy to know the demand and the gas production potential, one can decide to make specific measures while designing the plant in a way to balance the P and D variables. It is also very easy to use the spreadsheet and any one can work with it.

User inputs into the model

Fuel consumption amount of each fuel	Fire wood (kg /HH per month)
	Charcoal (kg /HH per month)
	Dung cake(kg /HH per month)
	Kerosene (Liter /HH per month)
Number of family in HH	
Number of cooking meal per day	
Number of cattle in HH	
Average Weight of cattle	
Appliance usage Time (hr)	Cooking stoves
	Electric Lamps
Retention time	
Number of Electric Lamps	
Number of flame in the stove	
<i>Model out puts</i>	
Bio gas demand	
Bio gas production	
Digester volume	

Controllable inputs, also called **decision variables**, are quantities or factors that a decision maker can change (usually within limits) for the current situation. It is also called dependent variable. This variable is not directly which we can get from the survey. Here the controlled variables are retention time.

Uncontrollable inputs, sometimes called **parameters**, are quantities or factors that are important to the situation but are outside the decision maker's direct control. These variables are independent variables and are directly generated from the survey data. In this case Fuel consumptions, Number of family in the HH, Number of cattle, are uncontrollable variable

5.1 Flow chart for Biogas system Modeling

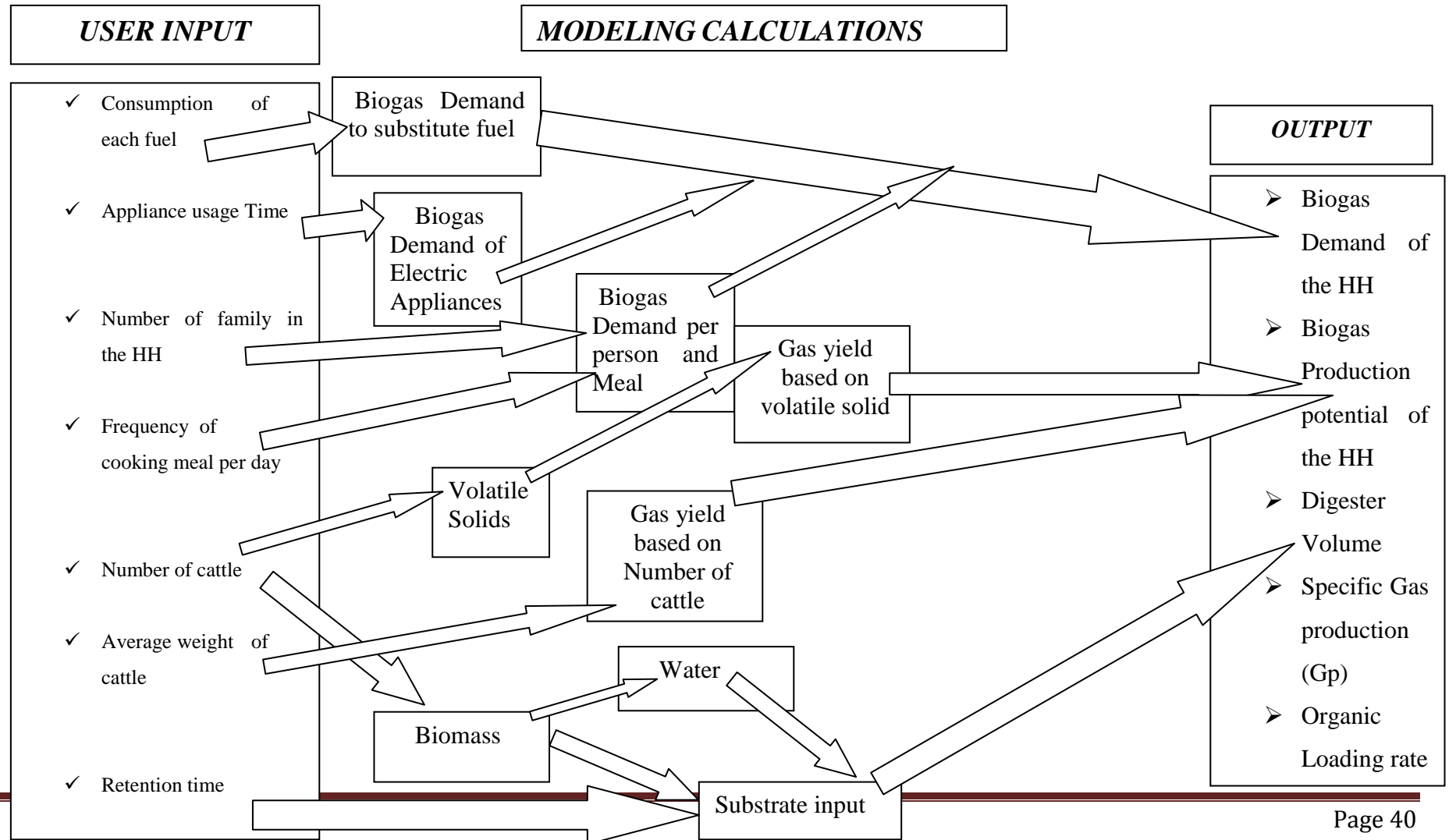

Flow chart for Biogas system Modeling

5.2 Model calculations

5.2.1 Biogas Demand (D)

Biogas demand (D) = D1 + D2 + D3 + D4.....Equation 1

D1 = Biogas demand to substitute fuels

D2 = Biogas demand per person and meal

D3 = Biogas demand of Gas Burner

D4 = Biogas demand for light

✓ (A). Biogas demand to substitute Fuels (D1)

Corresponding Biogas amount of Fuel wood can be calculated as

B1 = 200x1

Corresponding Biogas amount of dung cake can be calculated as

B2 = 100x2

Corresponding biogas amount of Charcoal can be calculated as

B3 = 500x3

Corresponding biogas amount of Kerosene can be calculated as

B4 = 166.7x4

The total biogas amount will be

D1 = B1 + B2 + B3 + B4

D1 = Biogas demand to substitute fuels

D1 = 200x1 + 100x2 + 500x3 + 166.7x4

D1 = 200x1 + 100x2 + 500x3 + 166.7x4

x1, x2, x3 and x4 Represent consumption values of Fuel wood, dung cake, Charcoal and Kerosene respectively.

✓ **(B). Demand per person and meal (D2)**

$$D2 = 0.15 \times \frac{\text{number of meal}}{\text{day}} \times \text{number of family members} \dots\dots\dots \text{Equation 2}$$

Here Biogas demand per meal is taken as 0.15 m³ per day (Uli Werner, NicoliHees)

✓ **(C). Demand for gas burner (to substitute cook stoves) (D3)**

$$D3 = \text{Operating time} \times \frac{0.175 \text{ m}^3}{\text{flame}} \times \text{number of flame in the cooker}$$

✓ **(D). Demand for lighting(D4)**

$$D4 = \text{number of lamp} \times \text{operating time} \times (0.12 \text{ m}^3)/\text{hr}$$

For the calculation of the biogas demand in the process of substituting the Electric appliances with biogas consuming appliances Gas consumption of lamp and the consumption rate of gas burner are:0.12 m³/hr per day and 0.175 m³/hr per flame ([https://www.energypedia.info/wiki/ Biogas Appliances](https://www.energypedia.info/wiki/Biogas_Appliances))

5.2.2 Bio gas production (G)

$$\text{Bio gas production (G)} = \frac{\text{G of volatile solid} + \text{G of number of animals}}{2}$$

✓ **(E). Volatile Solids. (VS)**

$$\text{Volatile solid (Vs)} = 1.8 \text{ kg VS per day and animal} \times \text{number of cattles}$$

✓ **(F). Gas yield based on Volatile Solids**

$$\text{G of Volatile solid} = \frac{\text{Kg}}{\text{d}} (\text{Volatile soild}) \times \text{Gy, Vs} = 0.25 \times \frac{\text{Kg}}{\text{d}} \text{Vs}$$

Gy, Vs (Gas yield potential of volatile solids) are 0.25 m³/Kg (Uli Werner, NicoliHees)

✓ **(G). Gas yield based on cattle number**

$$\text{G of cattle} = \text{Gy per cattle and day} \times \text{number of cattle}$$

Gy per cattle and day is take as 0.35 m³/Kg ,cattle(Uli Werner, NicoliHees)

$$= 0.35 \times \text{Number of cattle}$$

5.2.3 Digester volume (Vd)

$$\text{Digester volume (Vd)} = \text{Retention time(Rt)} \times \text{Substrate inpute(Sd)}$$

$$\text{Substrate inpute(Sd)} = \text{Water (W)} + \text{Biomass (B)}$$

✓ (I). Biomass

Biomass (B) = number of cattle × 10 %(Weight of cattle)(Uli Werner, Nicoli Hees)

✓ (J). water

Selected Water to Biomass ratio is 1: 3 (<http://www.fluid-biogas.com>)

✓ (K). Substrate input

$$\text{Substrate inpute(Sd)} = \text{Water (W)} + \text{Biomass (B)}$$

5.3 Using the Model for Analysis

Until now, we focused on the logic of the model, as well as ensuring that it is correct, flexible, and documented. All of this could have been done without knowing any of the specific numerical values for household Energy consumptions and other uncontrollable inputs. We now turn to using the model to help guide decision making. We have some basic data to use in the Spread sheet Model the equivalent values of household fuels in Biogas amount is determined based on this datum.

We can now perform what-if analysis; that is, we can enter any value into the user inputs cell, and the model will calculate the Biogas demand of the Household and the Biogas production potential of the household with the corresponding Digester volume needed to be designed. This will help in decision making process in the planning of Biogas plant for rural households.

5.3.1 Modeling report for the average values

For the average values, the spreadsheet calculation tool *the Biogas demand*, the gas generating potential of the Households and digester volume needed are 6.001m³/day, 6.8 m³/ day and 20.3949 m³ respectively. The values gained using manual calculations are 6.114m³/day, 6.8m³/day and 20.4 m³.

BIOGAS PLANT DESIGN ESTIMATION

USERS INPUT

Consumption of Fire wood	137.7
Consumption of Charcoal	62.57
Consumption of Dung cake	184
Consumption of Kerosene	2.43
Number of family in the HH	7
Frequency of meal cooking per day	2
Number of cattle	17
Average weight of cattle	250
Number of Lamp	2
Number of Cook stove	2
cook stove usage time	7
Lamp usage Time	5
Retention time	36

MODEL CALCULATIONS

Monthly Biogas demand to fuel	81.27581
Daily Biogas demand to substitute fuel	2.709193667
Biogas demand per person and Meal	2.1
Biogas Demand of Gas Burner	2.45
Biogas Demand of Lighting	1.2
Volatile solids	30.6
Biogas yield based on Volatile solids	7.65
Biogas Yield based on number of cattle	5.95
Total Biogas yield	13.6
Biomass	425
Water	141.525
Substrate input	566.525
Digester volume in Litters	20394.9

MODEL OUTPUT

Biogas Demand of the HH	6.009193667
Biogas production potential of the HH	6.8
Digester Volume	20.3949
Specific gas production Gp	0.333416688
Loading rate	1.500375094

Economic report

COST ESTIMATION OF CONSTRUCTION			
REQUIREMENTS	QUANTITY	UNIT PRICE (ETB)	TOTAL PRICE
Digging operations (m ³)	40	28	1120
Cement bags	10	450	4500
Gravel	20	230	4600
Rigid plastic pipes (m)	8	75	600
Gas pipes (m)	250	30	7500
Main Gas pipe (m) and 1" diameter	20	75	1500
Gas valve and connectors	20	80	1600
Brick	300	3	900
Labor	5	100	500
Skilled Masonry (number of days * Workers)	28	200	5600
		TOTAL	28420
		CONTIGENCY 5%	1421
		TOTAL MONEY IN (ETB)	29841

Initial cost (ETB)	29841
Annual cost (ETB)	7421.4567
Discount rate , r	0.12
project period in years (n)	15
$(1+r)^n$	5.473565759
$r*(1+r)^n$	0.656827891
$[(1+r)^n - 1]$	4.473565759
$[(1+r)^n - 1]/(r*(1+r)^n)$	6.810864489
Total benefits during the lifetime of the project (Pb) ETB	139302.1457
The present costs during the lifetime of the project (Pc) ETB	80387.5359

ECONOMIC OUTPUTS	
Net Present Value (NPV) ETB	58914.60983
Annual saving (As)	13031.47493
Simple pay back period (SPP) in Years	2.289917309
The benefit cost ratio	1.732882395

5.3.2 Modeling report for the Pick values

For the peak values, calculations in the spreadsheet modeling tool shows the *Biogas demand, the gas generating potential of the Households and the digester volume needed* are 9.19m³/day, 8.8 m³/ day and 26.3934 m³ respectively. Whereas results found for the corresponding value using the manual calculations are 9.16m³/day, 8.8m³/day and the digester volume is 26.399 m³.

BIOGAS PLANT DESIGN ESTIMATION

USERS INPUT	
Consumption of Fire wood	200
Consumption of Charcoal	90
Consumption of Dung cake	230
Consumption of Kerosene	3.5
Number of family in the HH	12
Frequency of meal cooking per day	2
Number of cattle	22
Average weight of cattle	250
Number of Lamp	3
Number of Cook stove	2
cook stove usage time	7
Lamp usage Time	5
Retention time	36
MODEL CALCULATIONS	
Monthly Biogas demand to fuel	113.8345
Daily Biogas demand to substitute fuel	3.794483333
Biogas demand per person and Meal	3.6
Biogas Demand of Gas Burner	2.45
Biogas Demand of Lighting	1.8
Volatile solids	39.6
Biogas yield based on Volatile solids	9.9
Biogas Yield based on number of cattle	7.7
Total Biogas yield	17.6
Biomass	550
Water	183.15
Substrate input	733.15
Digester volume in Litters	26393.4
MODEL OUTPUT	
Biogas Demand of the HH	9.194483333
Biogas production potential of the HH	8.8
Digester Volume	26.3934
Specific gas production Gp	0.333416688
Loading rate	1.500375094

Economic report for the pick value

COST ESTIMATION OF CONSTRUCTION			
REQUIREMENTS	QUANTITY	UNIT PRICE (ETB)	TOTAL PRICE
Digging operations (m ³)	50	28	1400
Cement bags	13	450	5850
Gravel	22	230	5060
Rigid plastic pipes (m)	10	75	750
Gas pipes (m)	255	30	7650
Main Gas pipe (m) and 1" diameter	20	75	1500
Gas valve and connectors	20	80	1600
Brick	320	3	960
Labor	5	100	500
Skilled Masonry (number of days * Workers)	28	200	5600
		TOTAL	30870
		CONTIGENCY 5%	1543.5
		TOTAL MONEY IN (ETB)	32413.5

Initial cost (ETB)	32413.5
Annual cost (ETB)	8061.23745
Discount rate , r	0.12
project period in years (n)	15
$(1+r)^n$	5.473565759
$r*(1+r)^n$	0.656827891
$[(1+r)^n - 1]$	4.473565759
$[(1+r)^n - 1]/(r*(1+r)^n)$	6.810864489
Total benefits during the lifetime of the project (Pb) ETB	185570.3548
The present costs during the lifetime of the project (Pc) ETB	87317.49589
ECONOMIC OUTPUTS	
Net Present Value (NPV) ETB	98252.85894
Annual saving (As)	19184.9888
Simple payback period (SPP) in Years	1.689524051
The benefit cost ratio	2.125236792

The economic analysis using the spreadsheet modeling shows that an investment cost to build a biogas plant for the average energy consumption is ETB 29841, annual savings (As) of ETB 13031.475 and payback period of 2.28 years with cost benefit ratio of 1.7.

Where the values gained through manual Economical calculations are ETB 29,840 for the investment cost and annual savings ETB 9584 with a payback period of 3 years and with a Benefit cost ratio (BCR) of 1.44 which is greater than 1.

Since the values are very approximated, this shows that the spreadsheet is functioning properly for the values to be feed by the users in the user inputs. After getting the values in the user out put one can make a decision to manipulate which demand of the Energy consumption should be given the first priority in meeting the household Energy demand. This as a result will help the design of the biogas plant.

5.4 Checking the Model with calculation

To check the Functionality of the prepared model each values should be analyzed

5.4.1 Daily gas demand (D)

Since the aim is to substitute the current energy consumption of rural households with a biogas technology the calculation is started with estimating the daily biogas demand. The daily bio-gas demand is calculated to estimate how much amount biogas could satisfy the Present rate of energy consumption and demand. This estimation is done based on literature values for the corresponding amount of consumption.

There are different approaches to estimate gas demand. The following alternative methods of calculation are useful (GTZ, 1989).

a) Determining biogas demand on the basis of present consumption: This involves measuring the present rate of energy consumption in the form of Fire Wood, Charcoal, Kerosene, Electricity etc.

b) Calculating biogas demand by means of comparable use data: such data may consist of

- ✓ Empirical values from neighboring systems, for example biogas consumption per person & day.
- ✓ Reference data taken from literature, although this approach involves considerable uncertainty, since cooking energy consumption depends on local culture eating habits; therefore differ substantially from case to case.

c) Estimating biogas demand by way of appliance consumption data and assumed periods of use: - This approach can only work to the extent that the appliances to be used are known in advance

Basic data

Table 5 Organized data from the survey for calculation.

		Average amount	Maximum (Pick values)
Consumptions	Fuel wood	(137.7 kg) /HH per month	(200kg)/HH per month
	Dung cake	(184 kg) / HH per month	(230Kg)/HH per month
	Charcoal	(62.57 kg) /HH per month	(90Kg)/HH per month
	Kerosene	(2.4375liters)/HH per month	(3.5liters)/HH per month
Appliances	Lamp	1.64 Lamps 5.7 hr/day	3
	Cook stove	2	2
Number of family members		7	7

✓ 7-person family, 2 meals per day.

Present rate of energy consumption:

Fuel wood: (137.7 kg) /HH per month

Dung cake: (184 kg) / HH per month

Charcoal: (62.57 kg) /HH per month

Kerosene: (2.4375 liters)/HH per month

Electricity: 1.64 Lamps and 5.7 hr/day each

Desired degree of coverage with biogas

Cooking: all

Lighting: 1.64 lamps, 5.7 hr/day each

Cooling: No

Cooking

1. Present fuel demand for cooking:

Since the observed consumption for cooking relay on fuel wood, dung cake and charcoal. The corresponding amount of biogas needed to substitute is calculated with a following manner.

Biogas System Planning for Rural Households based on Energy Demand

From values found in Literature 1 kg firewood corresponds to 200 L biogas, 1 kg dried cow dung corresponds to 100 L biogas and 1 kg charcoal corresponds to 500 L biogas and 0.6 L of kerosene corresponds to 1 m³ (1000 L) of biogas.

Type of Fuel	Ratio to Corresponding Biogas Amount
Fuel wood	1kg :200 liters
Dung Cake	1kg :100 liters
Charcoal	1kg :500 liters
Kerosene	0.6 litter: 1000 liters

The total amount of Biogas calculated is calculated

Corresponding Biogas amount of Fuel wood can be calculated as

$$B1 = 200x1$$

Corresponding Biogas amount of dung cake can be calculated as

$$B2 = 100x2$$

Corresponding biogas amount of Charcoal can be calculated as

$$B3 = 500x3$$

Corresponding biogas amount of Kerosene can be calculated as

$$B4 = 166.7x4$$

The total biogas amount will be

$$B = B1 + B2 + B3 + B4$$

$$B = 200x1 + 100x2 + 500x3$$

$x1, x2, x3$ and $x4$ are average values of Fuel wood, dung cake, Charcoal and Kerosene respectively.

Type of Fuel	(Liters) Biogas /HH per month	(Liters) Biogas /HH per day	(Liters) Maximum consumption / HH	
			Monthly	Daily
Fuel wood	27, 540	918	40, 000	1333
Dung Cake	1840	613.3	23, 000	760
Charcoal	31,285	1042	45, 000	1500
Kerosene	2437.5	81.25	3500	116.6
TOTAL	63,102.5 Liters (63.1025 m ³)	2654.55 Liters (2.654 m ³)	111,500 Liters (111.5 m ³)	3716.67 Liter (3.71667 m ³)

2. Gas demand per person and meal:

Average amount of 2 meals per day are assumed for this calculation. From Literatures biogas demand per meal is of 0.15 m³.

$$\begin{aligned} \text{Total Gas demand per meal: } & 0.15\text{m}^3 \text{ (7 persons)} \\ & = 1.05 \text{ m}^3 \text{ biogas} \end{aligned}$$

$$\text{cooking energy demand} = 2.1 \text{ m}^3 \text{ biogas}$$

The maximum number of family size is 12 and the daily Gas demand per meal is

$$0.15\text{m}^3 \text{ (12 persons)} * 2 = 3.6 \text{ m}^3 \text{ Per meal}$$

2. Consumption rate of gas burner:

Consumption rate of gas burner

$$\frac{175\text{l}}{\text{h}} \text{ per flame (2 flame cooker)}$$

$$\text{Operating time} = 2 \times 3\text{hr} + 1 \text{ hr for tea}$$

$$\text{Biogas demand} = 7\text{hr} \times 350 \text{ Litter} = 2.5 \text{ m}^3$$

Defined cooking energy demand

$$= 2.5\text{m}^3 \text{ biogas/d}$$

- The consumption for the maximum number of cooking stoves observed is the same as the above value.

Lighting

From the present consumption 1.64 Lamps give light 5.7 hr/day each. Since the biogas technology is intended to Substitute the current consumption. We use the biogas consumption rate of a lamp which gives light using biogas. For the sake of calculations average number of lamp is taken to be 2 and each of them gives light 5.7 hr/ day. From literatures Gas consumption of lamp is 120 L/hr

$$\text{operating time} = 2 \times 5.7 \text{ hr} = 11.4\text{hr}$$

$$\text{Biogas demand} = 11.4 \text{ hr} \times \frac{120\text{l}}{\text{h}}$$

$$= 1368 \text{ Litters}$$

- The maximum observed number of Lamp is 3 and with operating time 5 hrs each.

$$\text{operating time} = 3 \times 5 \text{ hr} = 15\text{hr}$$

$$\text{Biogas demand} = 15 \text{ hr} \times \frac{120\text{l}}{\text{h}}$$

$$= 1800 \text{ Litters}$$

Table 6 Summary of Biogas demand for the HH

Biogas Demand of households with Priority		
Average Demand	1st priority:	4.754
	cooking	
	2 nd priority:	1.36
	2 lamps	
Maximum Demand	1st priority:	7.36
	cooking	
	2 nd priority:	1.8
	3 lamps	

5.4.2 Biomass supply/Biogas production (P)

Basic data

Average values	
Amount of fertilizer for annual use	2.2 sack of quintal
Number of cattle	17
Body weight	250 kg

17 head of cattle, 250 Kg each,

Daily Biomass incidence

Animal dung calculated as % live weight (as per 1.) or as daily yield per head

(as per 2) as listed on (Uli Werner, Nicol Hees)

➤ **1. Dung as % live weight**

Daily yield per head of cattle : 10% of the weight of the cattle

$$250kg = \frac{25kg}{d}$$

(Volatile solids)/day : 1.8 kg VS per day and animal

$$= \frac{VS}{1.8} = 17 \dots \dots \dots \text{Equation 1}$$

Total yield $\frac{425kg}{d}$ And $\left(30.6 \frac{kgVS}{d}\right)$

5.5 Sizing the Digester

The size of the digester, i.e. the digester volume V_d , is determined on the basis of the chosen retention time R_T and the daily substrate input quantity S_d .

$$V_d = S_d * RT \left(m^3 = \frac{m^3}{day} * number\ of\ days \right) \dots\dots\dots Equation\ 2$$

The retention time, in turn, is determined by the chosen/given digesting temperature. For an unheated biogas plant, the temperature prevailing in the digester can be assumed as 1-2 Kelvin above the soil temperature. Seasonal variation must be given due consideration, however, i.e. the digester must be sized for the least favorable season of the year. The substrate input depends on how much water has to be added to the substrate in order to arrive at a solids content of 4-8%.

$$Substrate\ input\ (S_d) = biomass\ (B) + Water\ (W) [m^3/d] \dots\dots\dots Equation\ 3$$

In most agricultural biogas plants, the mixing ratio for dung (cattle and / or pigs) and water (**B: W**) amounts to between 1:3 and 2:1. (<http://www.fluid-biogas.com>)

Basic data

Daily biomass: 306kg/d

VS: 26.775kg/d

TS-content: 12%

Soil temperature: max 31 °C, min. 22 °C, average 25 °C

Digester volume (Vd)

Retention time (chosen): $RT = 36\ d$ (at 25°C, i.e. $f = 1.0$)

Substrate input (Sd) = biomass (B) + Water (W) [m3/d]

Daily water input: Wd = 142 kg

Sd = 142 + 425 = 567 liters

*Digester volume: Vd = 567 liter * 36 days = 20.4 m³*

Daily biogas yield

$$G = \frac{Kg}{d} VS \times Gy, vs$$

$$= \frac{30.6 \text{ kg}}{d} * 0.25 = 7.65 \text{ m}^3/\text{d}$$

$$G = \text{number of animals} * Gy \text{ per animal} * d$$

$$= 17 * 0.35 = 5.95$$

$$G = (G1 + G2)/2$$

$$G=6.8 \text{ m}^3/\text{d}$$

5.6 Balancing the biogas production and demand

Since this study needed to identify the amount of Biogas needed to meet the energy demand of the surveyed households, it is very important to focus on two possible scenarios. The first possible scenario will be concerning on balancing the average daily energy demand and the average gas production amount. In this case the calculations indicate that the average calculated values of the average Energy demand (D) is 6.114m³/d and with the average daily gas production rate (P) of 6.8m³/d

1st priority: cooking	4.754
2nd priority: 2 lamps	1.36

Demand (D): 6.114m³/day

Production (P): 6.8m³/d

Here the average energy demand (D) and gas production (P) rate are in a level which can fully satisfy the planned energy demand priorities. Since the amount of daily gas production rate (P) is greater than from the amount of energy demand (D), it can satisfy the households' energy demand.

5.6.1 Pick value

For the observed maximum amount of Biogas demand from the surveyed households, the production amount (P) will not satisfy all the Energy demand (D). Even though the production amount can satisfy the energy needed for cooking but it will not be enough to cover the lighting energy demand. Since our intention is to cover most of the energy demand of the households with Biogas energy we should consider some options to do some changes and accommodations to balance the Energy demand and the production.

- Maximum energy demand is (D) 9.116 m³/d

1st priority: cooking	7.36
2nd priority: 3 lamps	1.8

➤ The maximum Gas production observed is (P) 8.8 m³/d

Gy, Vs (Gas yield potential of volatile solids) is 0.25 m³/Kg, Volatile Solids (Kg) per day and cattle is 0.18 and Potential of Gas yield of cattle (m³/Kg, cattle) (Uli Werner, NicoliHees)

$$G = \frac{\text{Kg}}{\text{d}} \text{VS} \times \text{Gy, vs} \dots\dots\dots \text{Equation 4}$$

$$\text{VS} = \text{number of cattle} * \text{Volatile Solids(KG)per day and cattle} \left(\frac{\text{VS}}{\text{day}} \text{per cattle} \right)$$

$$\text{VS} = 22 * 1.8 = 39.6 \text{ Kg/day}$$

$$G1 = 39.6 * 0.25 = 9.9 \text{ m}^3/\text{day}$$

$$G = \text{number of animals} * \text{Gy per animal} * d$$

$$= 22 * 0.35 = 7.7$$

$$G = \frac{G1 + G2}{2} = 8.8 \text{ m}^3/\text{day}$$

The volume needed for the peak energy demand is $Vd = Sd * Rt$

The Substrate input from the maximum cattle number is

$$\text{Subatrte input (Sd)} = \text{biomass (B)} + \text{Water (W)} [\text{m}^3/\text{d}]$$

Daily yield per head of cattle : 10% of

$$250 \text{ kg} = \frac{25 \text{ kg}}{d}$$

(Volatile solids)/day : 1.8 kg VS per day and animal

$$= \frac{\text{VS}}{1.8} = 22 \dots\dots\dots \text{Equation 5}$$

$$\text{Total yield } \frac{550 \text{ kg}}{d} \text{ And } \left(39.6 \frac{\text{kgVS}}{d} \right)$$

$$\text{Daily water input: } Wd = 183.33 \text{ kg}$$

$$Sd = 183.33 + 550 = 733.33 \text{ liters}$$

➤ Digester volume for the peak values : $Vd = 733.33 \text{ liters} * 36 \text{ days} = 26.399 \text{ m}^3$

5.6.1.1 Demand side accommodations

Since the amount of the demand side is much greater than the production side, we should choose on which demand to meet first based on our planned priorities. Since we gave the first priority for cooking energy demand and we can meet that demand from the production side. For these values we can made changes and accommodations on the demand side: 2 less lamp, reducing the demand to 6.68 m³. The first option will be the cooking energy demand can be covered with the produced bio-gas amount and the lighting energy demand will be meet with 1 lamp which uses biogas and also by the previous options the households use for lighting their houses. These options can be electricity or kerosene.

5.6.1.2 Production side accommodations

Production side: increasing the digester volume, resulting in a retention time and a daily gas yield using Equation (2)

$$Vd = Sd * RT \text{ [m}^3 = \text{m}^3/\text{day} \times \text{number of days]}$$

The volume of slurry in the digester remains constant; the incoming slurry displaces an equal amount of processed slurry from the digester each time the digester is loaded. Since the volume is constant, the fraction of the digester's liquid volume replaced each day determines the retention time. For example, if slurry equaling one-tenth of the digester's liquid volume is added daily, the digester slurry has an average retention time of 10 days. For a plant of simple design, the retention time should amount to at least 40 days. Practical experience shows that retention times of 60-80 days, or even 100 days or more, are no rarity when there is a shortage of substrate. On the other hand, extra-long retention times can increase the gas yield by as much as 40%. The retention time, in turn, is determined by the chosen/given digesting temperature. For an unheated biogas plant, the temperature prevailing in the digester can be assumed as 1-2 Kelvin above the soil temperature. Seasonal variation must be given due consideration, however, i.e. the digester must be sized for the least favorable season of the year. For a plant of simple design, the retention time should amount to at least 40 days. Brief retention time does not allow the bacteria enough time to digest the manure, and a long retention time does not furnish enough fresh slurry to promote bacterial growth and a high gas production rate.

5.7 Plant parameters

The degree of safe-sizing certainty can be increased by defining a number of plant parameters:

5.7.1 Specific gas production G_p

The daily gas generation rate per m^3 digester volume V_d , is calculated according to the following equation

$$G_p = \frac{G}{V_d} [(m^3/d) / m^3] \dots \dots \dots \text{Equation 6}$$

Digester volume: $V_d = 20.4 m^3$

Daily gas production: $G = 6.25 m^3$

Daily substrate input: $S_d = 408 l$

Specific gas production:

$$G_p = G/V_d$$

$$G_p = \frac{6.8 \left(\frac{m^3}{d} \right)}{20.4 m^3} = 0.33 m^3/d$$

5.7.2 Digester loading L_d

The digester loading L_d is calculated from the daily total solids input TS/d or the daily volatile solids input VS/d and the digester volume V_d : $[kg/ (m^3 d)]$

$$L_d = \frac{VS/d}{V_d} [Kg/ (m^3 d)] \dots \dots \dots \text{Equation 7}$$

✓ **Digester loading:**

➤ **Loading rate of the total solid**

Digester TS-content = 7% (chosen) and then TS is calculated = 7 % (408 l)
 =28.56KgTS/ m^3 and V_d : 20.4 m^3 .

$$L_d = \frac{TS}{V_d} \dots \dots \dots \text{Equation 8}$$

$$\frac{\left(\frac{28.56\text{kg}}{d}\right)}{20.4\text{ m}^3} = 1.4\text{kgTS}/\text{m}^3\text{ Vd}$$

$$Ld = 1.4\text{ kg TS}/\text{m}^3\text{ Vd}$$

➤ **Loading rate of volatile solid**

27 kg VS/d and Vd: 20.4 m³

$$Ld = \frac{Vs}{Vd}$$

$$\frac{\left(\frac{27\text{kg}}{d}\right)}{20.4\text{ m}^3} = 1.32\text{ kg}/\text{m}^3$$

$$Ld = 1.3\text{ kg VS}/\text{m}^3\text{ Vd}$$

5.8 Sizing the Gasholder

The size of the gasholder, i.e. the gasholder volume **Vg**, depends on the relative rates of gas generation and gas consumption.

The gasholder must be designed to:

- cover the peak consumption rate gC_{max} ($>Vg1$) and
- hold the gas produced during the longest zero-consumption period

$$tZ_{max} (>Vg2)$$

$$Vg1 = gC_{max} \times tC_{max} = VC_{max} \quad Vg2 = Gh \times tZ_{max} \dots \dots \dots \text{Equation 9}$$

With gC_{max} = Maximum hourly gas consumption [m³/h]

tC_{max} = time of maximum consumption [h]

VC_{max} = maximum gas consumption [m³]

Gh = hourly gas production [m³/h] = $\frac{G}{24h} / d$

tZ_{max} = maximum zero-consumption time [h]

The larger **Vg** value (**Vg1** or **Vg2**) determines the size of the gasholder. A safety margin of 10-20% should be added:

$$Vg = 1.15 (\pm 0.5) \times \max (Vg1, Vg2)$$

Practical experience shows that 40-60% of the daily gas production normally has to be stored. The ratio Vd/Vg (digester volume / gasholder volume) is a major factor with regard to the basic design of the biogas plant. For a typical agricultural biogas plant, the Vd/Vg ratio amounts to somewhere between 3:1 and 10:1, with 5:1 - 6:1 occurring most frequently.

✓ **Gasholder volume:**

$Vg = 2.6 \text{ m}^3$, as calculated on the basis of:

✓ **consumption volume:**

$Vg1 = 0.175 \text{ m}^3/\text{h} \times 2 \text{ flames} \times 3 \text{ h} = 1.05 \text{ m}^3$

✓ **Storage volume:**

$Vg2 = 10 \text{ h} \times 0.26 \text{ m}^3 \text{ gas/h} = 2.6 \text{ m}^3$

$Vd/Vg = 20.4 : 2.6 = 8:1$

Table 7. Calculating parameters for fixed-dome biogas plant (Source: Sasse 1984.)

$Vg : Vd$	1:5	1:6	1:8
R	$(0.76 \cdot Vd)^{1/3}$	$(0.74 \cdot Vd)^{1/3}$	$(0.72 \cdot Vd)^{1/3}$
R	0.52 R	0.49 R	0.45 R
H	0.40 R	0.37 R	0.32 R
P	0.62 R	0.59 R	0.50 R

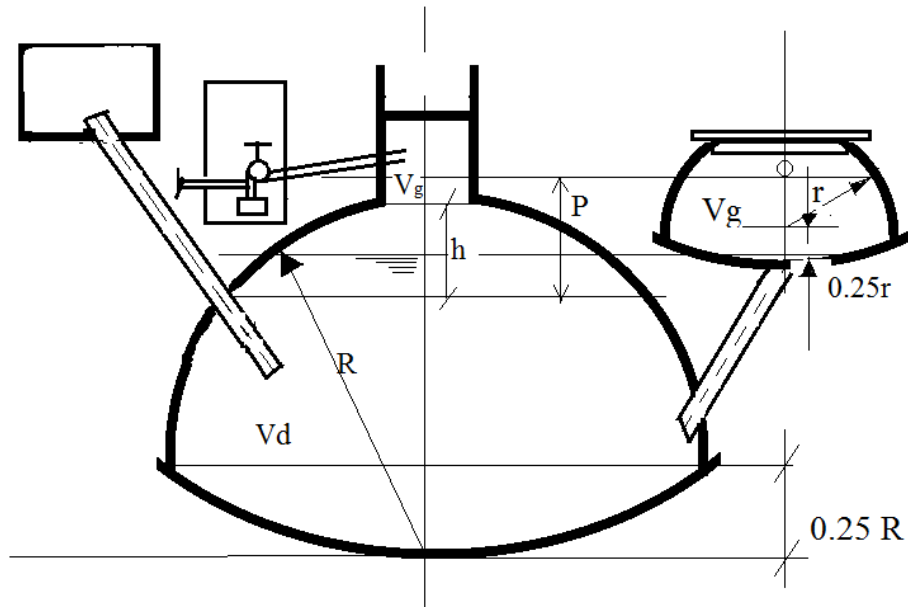

Figure 6 basic dimensions of the digester (Source: Sasse1984.)

$$R = (0.72 \cdot Vd)^{1/3}$$

$$R = (0.72 * 20.4)^{1/3} = 2.448 \text{ m}$$

$$r = (0.45 R) = 1.1016 \text{ m}$$

$$h = (0.32R) = 0.78 \text{ m}$$

$$p = (0.50 R) = 1.224 \text{ m}$$

Inlet and Out let pipe

Size of inlet and outlet pipe is equal to the diameter of the tube that directly connected to the septic tank i.e. (110 – 150mm) by making some stepped angle to make turbulence to avoid scum formation in digester.

Expansion Chamber

Size of expansion chamber is equal to the volume of gasholder in fixed dome biogas plant, but biogas stored in pressure vessel out of digester. However, the design of expansion chamber is in order to avoid over flow of raw substrate (unfermented substrate) 2.6m³ expansion chambers is coupled to the digester.

Compost Tank

Compost tank is an integral part of the biogas plant; no plant is complete without it. Enough earth body must exist, at least one meter, between the compost tank and the outlet chamber to avoid cracking of the chamber walls. The volume of the compost tank must be at least equal to the plant volume (BSP, 1994).

Selecting the Type of Fixed Dome Plant

Part of digester below the ground level is subjected to heavy compressive load due to the earth pressure, which increases with depth. In this design due to hydrostatic pressure cylindrical digester was selected. Deenbandhu fixed dome plant with a little modification is best suited. Deenbandhu, the successor of the Janata plant in India, with improved design, is more crack proof and consumes less building material than the Janata plant with a hemispherical digester (FAO/CMS, 1996 and Mattocks, 1984).

Other reasons that support this choice are:

- ✓ Constructing the digester underground reduces the negative impacts resulted from atmospheric temperature changes,
- ✓ Raw substrate from the cattle dung has odor, hence it should be beneath under earth.
- ✓ It distributes forces uniformly on surface area

CHAPTER SIX: ECONOMICAL ASPECTS OF BIOGAS

Biogas is a renewable energy which is eco-friendly and minimizes expenditure on the foreign exchanges on the import of fossil fuels.

The biogas plant demands a relatively high capital investment. The economics of various different alternatives available for the households need to be analyzed, so that the best one can be chosen. Any decision for or against the construction and operation of a biogas plant depends on various technical criteria as well as on a number of economic and utility factors. Users want to know what the plant will offer in the way of profits (cost benefit analysis) and advantages like reduced work load, more reliable energy supplies or improved health. There are many ways to approach economic analysis, depending on the point of view from which plant is considered. The simplest approach is, look at the cash flow position of the households.

Table 8 Average prices of monthly fuel consumption.

Source of Energy	Monthly fuel consumption per family	
	Unit	Price (ETB)
Fuel wood	(137.7 kg) /HH per month	200
Dung cake	(184 kg) / HH per month	50
Charcoal	(62.57 kg) /HH per month	293
Kerosene	(2.4375 liters)/HH per month	27.708
Electricity	- / HH per month	37
TOTAL=607.708 Birr		

6.1 Construction Materials and Costs

After collecting information from many expertise people those who are working concerning Rural Energy Development in rural energy development, Promotion and dissemination Center of Ethiopia, the costs for constructing the proposed design (i.e. 20.4 m³) biogas plant may be estimated as follows.

Table 9 Cost estimation of construction

No	Requirements	Qty	Price /cost in Birr	
			Unit Price	Total Price
1	Digging operations	40m ³	28	1,120
2	Cement bags/pieces	10	450	4500
3	Gravel	20	230	4,600
4	Rigid Plastic pipes	8 m	75	
5	Gas pipe	250 m & 1/2" diameter	30	7500
6	Main gas pipe (galvanized steel)	1" diameter & 20m	75	1500
7	Gas valve & connectors	20	80	1600
8	Brick	300	3	900
9	Labor	5 person	100	500
10	Skilled Masonry	2person 14 days	200	5600
		Total	28,420	
		Contingency 5%	1421	
		Total money in Birr	29,840	

6.2 Financial Analysis

To assume Projects as economically feasible the Net Present Value (NPV) should be positive and the internal rate of return (IRR) should be $\geq 20\%$ and a payback period of ≤ 5 years. The major parameters that need to be considered for the financial feasibility, of biogas plants are:

a) Project life

A fixed dome type plant could last for more than 40 years depending on the quality of construction and the materials used. However, the economic life of a plant is taken as 20 years mainly because any cost or benefit accrued after 20 years will have insignificant value when discounted to the present worth

b) Benefits and Cost

All benefits of a biogas plant cannot be readily priced or even compared with the price of similar products or services in the market. For example, it is difficult to put a money value for the benefit of decrease environmental pollution. This indicates that even if the financial analysis shows zero net benefit of constructing a biogas plant, it should be interpreted as having positive net benefits owing to the un-priced factors.

The biogas plants produce both biogas and organic fertilizer. The biogas could be used mainly instead of firewood, charcoal, kerosene and etc. while organic fertilizer used to improve crops yield, and so could be used instead of manufactured fertilizers. Therefore; the annual direct financial benefits for biogas plants could be estimated as follows:

$$Ba = Bab + Baf - Ca \dots \dots \dots \text{Equation (10)}$$

Where

Ba = Annual benefit

Bab = Annual benefit from Biogas

Baf = Annual benefit from organic fertilizer

Ca = Annual cost

Benefit from Biogas

The proposed biogas system designed to produce biogas quantity could cover the monthly consumption of households from charcoal, kerosene, firewood and electricity. So the annual sum saving expected from using biogas is Birr 4,620 per household.

Organic Fertilizer

Amount of organic matter gets out from digester into compost tank is:

$$Om = La - Cb \dots \dots \dots \text{Equation (11)}$$

Where,

Om=Organic matter gets out from digester

La=Loaded amount of substrate

Cb=organic matter converted into biogas

$$\begin{aligned} Om &= La - Cb \\ &= 0.7 * 408 * 30 * 12 - 0.42 * 408 * 30 * 12 \\ &= 41,126.4\text{kg per year} \end{aligned}$$

Manufactured fertilizer of the lowest price available in the local markets is Urea fertilizer which sales to farmer by about 1200 Birr/ 100kg .By selling the organic matter gets out of the digester by 10 % Urea price, and then the price of 900kg:

$$\text{Ofp} = \text{Birr } 9,720 \text{ per Year}$$

Annual Cost

Annual cost for operating a biogas plant may come from replacing some used equipment (mainly gas valve, gas transporting pipe and etc.), i.e. is maintenance cost & operational cost.

6.3 Economic Analysis

Some of benefits and costs of biogas plants are not limited to the users. If a large number of biogas plants are installed in a community, the non-users will also be benefited avoidance of environmental pollution and conservation of forest in area. Such benefits and costs that increase even outside of the user households is a subject matter of economic analysis and not of financial analysis. A single biogas plant does not significantly affect the economy as a whole. Economic analysis measures the effect of biogas program on the fundamental objectives of the whole economy.

Table 10 Economic Analysis

Years	1	2	3	4	5 to 15 yrs
Saving fuel wood	2400	2400	2400	2400	2400
Saving Charcoal	3516	3516	3516	3516	3516
Saving Kerosene	336	336	336	336	336
Saving Dung cake	600	600	600	600	600
Saving Electricity	444	444	444	444	444
Saving from fertilizer cost	9720	9720	9720	9720	9720
Total	17,016	17,016	17,016	17,016	17,016
Costs (Birr)					
Investment	29,840				
Maintenance	2277	2277	2277	2277	2277
Operation cost	5145	5145	5145	5145	5145
Total	37262	7422	7422	7422	7422
Net Benefit in Birr	-20,246	9594	9594	9594	9594

The net present value, benefit cost ratio and simple payback period are given as follows.

The present costs during the lifetime of the project are determined as

$$Pc = Ic + A\left(\frac{P}{A}, r, n\right) \dots \dots \dots \text{Equation (12)}$$

Ic = Initial cost

A =Annual cost

r =Discount rate

$$Pc = 29,840 + 7422\left[\frac{(1+0.12)^{15}-1}{0.12(1+0.12)^{15}}\right] \text{ at } r=12\% = 80,390 \text{ Birr}$$

The present value of benefits or saving during the life time of the project

$$Pb = A \left[\frac{(1+r)^n - 1}{r(1+r)^n} \right]$$

A = Annual benefit

Pb = Total benefits during the lifetime of the project

$$Pb = 17016 \left[\frac{(1 + 0.12)^{15} - 1}{0.12 (1 + 0.12)^{15}} \right]$$

$$= 115,893.6 \text{ Birr}$$

The Net Present Value is determined as

$$NPV = Pb - Pc \dots\dots\dots \text{Equation (13)}$$

$$NPV = 115,893.6 \text{ Birr} - 80,390 \text{ Birr}$$

$$= 35,503.67 \text{ Birr}$$

The annual saving is

$$As = Ab - Ac \dots\dots\dots \text{Equation (14)}$$

$$As = 17016 \text{ Birr} - 7422 \text{ Birr}$$

$$= 9594 \text{ Birr}$$

Simple Payback Period

Simple payback period is a time needed to recover the original investment for the construction of the bio-gas plant. It represents the amount of years in which the investment is expected to pay for itself. It is given by:

$$SPP = \frac{Ic}{Ac} \dots\dots\dots \text{Equation (15)}$$

$$= \frac{29840}{9594}$$

$$= 3.11 \text{ years}$$

This means the households will get back the capital of constructing biogas plant with in a time of three years.

The benefit cost ratio

$$BCR = \frac{115,893.6}{80,390} = 1.44 \geq 1$$

CHAPTER SEVEN: CONCLUSION

From the study on the rural area of Holeta district most of the households' energy sources are traditional fuels. These traditional fuels include Fire wood; Dung cake and Charcoal. In addition to the great impact on the family's health and economy, these fuels contribute a lot on the Environmental pollution. Among the observed disadvantages of the traditional fuels; the time and money spent to meet the households Energy demand and the work load on women and children in collection and preparation are the basics one.

Rural households can benefit a lot from Bio-gas technology since the biomass from their livestock farm can be found easily and can be an input feed for the biogas technology. The plant can also help the households to save the costs spent for fertilizers.

Finally according to this research to meet the average Biogas energy demand of the 6.114 m³/ days biogas plant with a volume of digester 20.4 m³ is needed. For the observed pick energy demand, accommodations can be made either on demand side (D) based on the energy demand priorities we set or on Production side (P) by increasing retention time and also the digester volume to maximize the gas production rate.

The estimated cost to construct the plant for the average Energy consumption is ETB 29,840. With a payback period of 3 years and with a Benefit cost ratio (BCR) of 1.44 which is greater than 1.

CHAPTER EIGHT: RECOMMENDATION

Since the biogas technology is a green and clean technology, it will be a great benefit for the households and also for our country's environmental protection strategy. This technology is able to help the farmer families economically by helping them save the costs spent on traditional fuels and also they will be able to save costs spent to buy fertilizers. In addition to that it will be a source of income if they are able to sell the surplus fertilizer they get from the biogas technology. Health related problems will be avoided and the time spent in collection of fire wood and in the preparation of dung cake will be saved and can be used for another purpose. Since the cattle waste is very accessible for rural livestock farmers this technology will give a great deal of benefit in meeting their energy demand.

References

Ajaz Ahmed and Shahid Hussain Ansar, (2011)

Study on Economic Feasibility of Biogas plant for small town.

B. Kofler, (2014), towards a global Transformation-Bibliothek der Friedrich-Ebert Stiftung

Bekele Gadissa, (2011) Msc Thesis Addis Ababa university. (Biogas system design for condominiums and its feasibility.)

Biogas SA, (<http://www.biogassa.co.za>, accessed on the 20/04/2014).

Biomass Energy strategy Ethiopia, (2013), (Ethiopia Biomass Energy strategy and action plan, December, 2013)

Centre for Application of Renewable Energy : (<http://care.india.tripod.com>, accessed May 2014)

Dagninet Amare, (2014) Beyene Belay and Dagninet Amare, 2014. *Integrated Forest Management Plan in Five Selected Church Forests In Dera Woreda: Implication For Ecological Restoration and Biodiversity Conservation*. Forest Management Plan Report Submitted to NABU Bahir Dar Office. Bahir Dar, Ethiopia. April 2014, unpublished

Design of Small Scale Anaerobic Digesters for Application in Rural Developing Countries laurel Erika Rowse University of South Florida.

Encyclopedia-of-Alternative-Energy

http://www.daviddarling.info/encyclopedia/P/AE_plug_flow_digester.html
accessed on the 29/04/2014.

Eugene D. Coyle, (2014) Understanding the Global Energy Crisis Eugene D. Coyle
Military Technological College, Richard A. Simmons, 2014

Extension, America's Research-based Learning network-based

(www.extension.org/pages/30307/types-of-anaerobic-digesters (accessed May 2014))

FAO/CMS, 1996 and Mattocks, (1984). Economics

Friedr. Vieweg & Sohn) Uli Werner/ Ulrich Stohr/ Nicoli Hees

Growth and Transformation Plan II of The Federal democratic Republic of Ethiopia government (GTP II).

IFAD, (2011) Rural Poverty Report, 2011

Jamila Gilliam, Social Enterprise Entrepreneurs and National Biogas Programs/ Partnerships as Dissemination agents in Ethiopia University of Massachusetts Boston April 1, 2016

Nadew Tadele, (2014), the experience in Ethiopia

Peter Stuart, (2015), The Advantages and Disadvantages of Anaerobic Digestion As A Renewable Energy Source, Lough borough University

Peter Sutcliffe, (2013), Susanne Geissler, DietmarHagauer, Alexander Horst, Michael Krause, Peter Sutcliffe, 2013.Biomass Energy Strategy Ethiopia.23rd December, 2013. Energy for development Pdf.

Saidi T, (2005), Masekoameng K.E., Simalenga T.E. and Saidi T, 2005. Household energy needs and utilization patterns in the Giyani rural communities of Limpopo Province, South Africa Journal of Energy in Southern Africa.16 (3).

Singh, J. B, R. Myles and A. Dhussa.(1987) Manual on Deenbandhu Biogas Plant. Tata McGraw Hill Publishing Company Limited, India.

Singh, S.P.; Vatsa, D.K.; Verma, H.N. (1997) Problems with biogas plants in him achalpradesh.Bioresource.Technol, 59, 69–71.

Suppa, (2010) Introduction for Spreadsheet modeling: Supplement A (John Walkenbach)
The Advantages and Disadvantages Of Anaerobic Digestion As A Renewable Energy Source, Loughborough University.

Tsigie Simur Asres The Current Status of Traditional Biomass Energy Utilization and Its Alternative Renewable Energy Technology in the Amhara Region of Ethiopia

Uliwerner and Nicolai Hees (1989) Biogas Plant in Animal Husbandry

A Publication of the DeutschesZentrumfürEntwicklungstechnologien

Tilley, E.; Ulrich, L;Luethi, C,Reymond, P; Zurbruegg. C. (2014)

Addis Ababa University

School of postgraduate studies

Energy center

Department of energy technology

This questionnaire is prepared to assess the energy consumption of selected households who live in Holeta area. The data gathered from this assessment will help in the study concerning biogas production from cattle waste to substitute the traditional energy consumptions. Your willingness to give the correct information has a great value for the study.

Instruction

- ✓ No need to write your name
- ✓ If you couldn't find your answers in the given choice, you can write your answer shortly.

Personal information

1. Number of family members

Family income (Optional)

Energy Source, purpose and consumption

CHARCOAL

2. Use of Charcoal

Cooking Heating Home Both

3. Source of Charcoal

From Market Prepared in home

Biogas System Planning for Rural Households based on Energy Demand

4. Monthly consumptions per months in Kg (Sack)
5. Cost spent either to buy or to prepare Charcoal.
6. If your answer for question # 3 is “From Market”, then how is the price trend?
Increasing Decreasing No change observed
7. If your answer for question # 3 is “Prepared in home”, then how many hours is spent in preparation process?

FIRE WOOD

8. Use of fire wood
Cooking Heating Home Both
9. Source of fire wood
From Market collected from forest or private land
10. Monthly consumptions per months in Kg (fold)
11. Cost spent to buy fire wood.
12. If your answer for question # 9 is “From Market”, then how is the price trend?
Increasing Decreasing No change observed
13. If your answer for question # 9 is “collected from forest or private land”, then how much is the distance travelled?
-

DUNG CAKE

14. Use of Dung cake

Cooking Heating Home Both

15. Source of Dung cake

From Market collected from forest or private land

16. Monthly consumptions per months in Kg (Sacks)

17. If your answer for question # 15 is “From Market”, then how is the price trend?

Increasing Decreasing No change observed

KEROSENE

18. Use of kerosene

Cooking Heating Home Both

19. Monthly consumptions in liters

20. Cost spent either to prepare kerosene.

21. How is the price trend?

Increasing Decreasing No change observed

ELECTRICTY

22. Do you use Electricity?

Yes No

23. For what purpose you use electricity?

Cooking lighting other (Mention)

24. Do you have electric stove or electric?

Yes No

Biogas System Planning for Rural Households based on Energy Demand

25. Number of electric Stoves (if there is any)?

26. Number of Lamps

27. For how long the lamps give light in a day?

**INFORMATION ON CATTLES WEALTH AND FERTILIZERS
CONSUMPTION**

28. Number of cattle

29. The minimum and maximum cattle weight

30. Average dung collected from cattle in a day (Kg)

31. Amount of fertilizers consumed in a year

32. Money you spent to buy the fertilizers

አዲስ አበባ ዩንቨርሲቲ

የድህረ ምረቃ ትምህርት ክፍል

በኢነርጂ ማዕከል

የኢነርጂ ቴክኖሎጂ ትምህርት ክፍል

ይህ መጠይቅ የተዘጋጀው በሆለታ ከተማ አስተዳደር ውስጥ ያሉ የተመረጡ ነዋሪዎች በግብርና የሚተዳደሩ ነዋሪዎች የሀይል (የነዳጅ) ፍጆታ ለማጥናት ሲሆን ይህ መረጃ የከብት ሀብት ያላቸው ነዋሪ ከእንስሶች ለሚገኘው የከብቶች አዘባ ለሀይል ፍጆታ የሚጠቅም ባዩ ጋዝ ለማምረት በሚደረግ ጥናት ለሚረዳ ግብአት ሆኖ ይጠቅማል ።

የግለሰብ መረጃ የመንደር ስም

1. የቤተሰብ አባላት ቁጥር

የሀይልምንጭ ፣ ዓላማ እና ፍጆታ

2. ከሠል

2.1 ከሠልን የምጠቀምበት

- ሀ) ለማብሰል ለ) እቤት ለማሞቅ ሐ) ሀ እና ለ መ) ሌላ (ይገለፅ)

2.2 ከሠሉ የሚገኝበት መንገድ

- ሀ) በግዥ ለ) እራስ በማዘጋጀት ሐ) ሌላ (ይገለጽ)

2.3 የሚፈጀው የከሠል መጠን በኪሎ/ በማዳበሪያ

2.4 ከሠሉም ለመግዛትም ሆነ ለማዘጋጀት የሚፈጀበት ወጪ መጠን /ዋጋ / ወጪ

2.5 የተ.ቁ 4.2 መልስ፣ ሀ ፣ ከሆነ የቅርብ ግንኙነት የዋጋ ሁኔታ ሲታይ

- ሀ) ሲጨምር ነበር ለ) ሲቀንስ ነበር ሐ) ልዩነት አልነበረውም መ) አላውቅም

2.6 የተ.ቁ 4.2 መልስ፣ ለ፣ እርሶ ለማዘጋጀት የሚፈጀው ጊዜ በቀን ሲገለፅ ስንት

ቀን ይፈጃል-----

3. እንጨት (ማገዶ)

3.1 ማገዶን የምትጠቀሙት?

- ሀ) ለማብሰል ለ) እቤት ለማሞቅ ሐ) ሀ እና ለ መ) ሌላ (ይገለጽ)

3.2 ማገዶ የሚገኝበት መንገድ

- ሀ) በግዢ ለ) ከጫካ በመልቀም ሐ) ከግል መሬት የሚሰበሰብ
- መ) በሌላ መንገድ የሚገኝ (ይገለጽ)

3.3 የምትጠቀሙት የእንጨት/ ማገዶ መጠን በእስር /በማዳበሪያ -----

3.4 ማገዶውን ለመግዛት የምታወጡት ወጪ ምን ያህል ነው? -----

3.5 የተ.ቁ 5-2 መልስ ሆኖ ከሆነ የቅርብ ዓመታት የዋጋ ሁኔታ ሲታይ?

- ሀ) ሲጨምር ነበር ለ) ሲቀንስ ነበር ሐ) ልዩነት የለውም
- መ) እኔ አላውቅም

5.6 የተ.ቁ 5-2 መልስ ለ' / ሐ ከሆነ ለመሰብሰብ የሚፈጀው ጊዜ በሰዓት

- ሀ) በቀን ----- ለ) በሳምንት ሐ) ከወር

3.6 የተ.ቁ 5-2 መልስ ርቀት ምን ያህል ይሆናል (ይርቃል

3.7 የተ.ቁ 5-2 መልስ ለ' ለመሰብሰብ የምትሄዱት ርቀት ምን ያህል ይሆናል (ይርቃል? በሜትር /በኪ.ሜትር)

3.8 የተ.ቁ 5-2 መልስ ለ' ከሆነ ለመልቀም የሚሄዱበት ቦታ በዓመታት ውስጥ ሲታይ

- ሀ) ሲጨምር/እየራቀነው የመጣው ለ) ልዩነት አላሳየም ሐ) ሲቀንስ ነበር
- መ) አላውቅም

6.ኩባት

6.1 ኩባትን የምትጠቀሙት?

- ሀ) ለማብሰል ለ) ቤት ለማሞቅ ሐ) ሀ እና ለ መ) ሌላ ካለ ይገለጹ

6.2 ኩባት የሚገኝበት መንገድ?

- ሀ) በግዢ ለ) እራስ በማዘጋጀት ሐ) ሀ እና ለ

6.3 የምትጠቀሙት የኩባት መጠን በቁጥር /በኪ.ግ

1ኩባት -----ኪ.ግ

6.4 የ 6.2 መልስ ሆኖ ከሆነ የቅርብ ዓመታት የዋጋ ሁኔታ ስታይት?

ሀ) ሲጨምር ነበር ለ) ሲቀንስ ነበር ሐ) ልዩነት የለውም

7. ኬሮሲን ጋዝ

7.1 ኬሮሲን ጋዝን የምትጠቀሙት?

ሀ) ለማብሰል ለ) ለ መብራት ሐ) ሌላ ካለ ይገለፅ -----

7.2 የምትጠቀሙት የኬሮሲን ጋዝ መጠን በሊትር -----

7.3 ኬሮሲን ጋዝን ለመግዛት የምታወጡት ወጪ ምን ያህል ነው?

ሀ) በቀን----- ለ) በሳምንት----- ሐ) በወር-----

7.4 የቅርብ ዓመታት የዋ ጋሁኔታ ስታዩት

ሀ) ሲጨምር ነበር ለ) ሲቀንስ ነበር ሐ) ልዩነት የለውም

8.የኤሌክትሪክ ፍጆታ መጠን

8.1 ኤሌክትሪክ ይጠቀማሉ?

ሀ) አዎ ለ) አልጠቀምም

8.2 የሚጠቀሙ ከሆነ ለየትኞቹ ጥቅሞች ይውላል?

ሀ) ለማብሰል ለ) ለማብራት ሐ) ለማቀዝቀዝ መ) ሌላ (ካለይጠቀስ)-----

8.3 ለማብሰል የሚጠቀሙባቸው እቃዎች

ሀ) የኤሌክትሪክ ምድጃ ለ) የኤሌክትሪክ ምጣድ ሐ) ሌላ ካለ ይጠቀስ

8.4 የኤሌክትሪክ ምድጃ ብዛት

8.5 የኤሌክትሪክ ምድጃ ለምን ያህል ጊዜ ጥቅም ላይ ይውላል -----በሰዓት

ሀ) በቀን ----- ለ) በሳምንት----- ሐ) በወር----- በአመት-----

8.6 የኤሌክትሪክ ምጣድ ለምን ያህል ጊዜ ጥቅም ላይ ይውላል? -----(በሰዓት)

ሀ) በቀን ----- ለ) በሳምንት----- ሐ) በወር ----- መ)በአመት-----

8.7 የኤሌክትሪክ ጥቅም ላይ ይውላል -----በሰዓት

8.8 የኤሌክትሪክ ለምን ያህል ጊዜ ጥቅም ላይ ይውላል -----በሰዓት

ሀ) በቀን ለ) በሳምንት ሐ) በወር መ. በአመት

8.9 የ 8.2 መልስ ሐ" ከሆነ ስንት የማቅሻር ስልጣን አለው? -----

የማቅሻር መጠን (በሊትር) -----

9.1 የከብት መጠን

9.2 ከአንድ ከብት የሚገኝ የአዛባ መጠን

Biogas System Planning for Rural Households based on Energy Demand

APPENDIX

Spread sheet Modeling

MODEL CALCULATIONS	
Monthly Biogas demand to fuel	=(B5*'Basic informations'!B2)+('BIOGAS SYSTEM MODELING TOOL'!B6*'Basic informations'!B3)+(B7*'Basic informations'!B4)+('Basic informations'!B5*'BIOGAS SYSTEM MODELING TOOL'!B8)
Daily Biogas demand to substitute fuel	=B20/30
Biogas demand per person and Meal	=B9*B10*'Basic informations'!B11
Biogas Demand of Gas Burner	=B14*B15*'Basic informations'!B12
Biogas Demand of Lighting	=B16*B13*'Basic informations'!B13
Volatile solids	=IMPRODUCT(B11,'Basic informations'!B14)
Biogas yield based on Volatile solids	=IMPRODUCT(B25,'Basic informations'!B15)
Biogas Yield based on number of cattle	=IMPRODUCT(B11,'Basic informations'!B16)
Total Biogas yield	=B26+B27
Biomass	=IMPRODUCT(B11,B12,0.1)
Water	=IMPRODUCT(0.333,B29)
Substrate input	=SUM(B29+B30)
Digester volume in Litters	=B31*B17
MODEL OUTPUT	
Biogas Demand of the HH	=B21+B22+B24
Biogas production potential of the HH	=0.5*B28
Digester Volume	=0.001*B32
Specific gas production Gp	=B36/B37
Loading rate	=B25/B37

Biogas System Planning for Rural Households based on Energy Demand

ECONOMIC ANALYSIS					
YEARS	1	2	3	4	Year 5 to 15
Savings from fuel wood	=12*E14	=12*E14	=12*E14	=12*E14	=12*E14
savings from Dungcake	=12*E15	=12*E15	=12*E15	=12*E15	=12*E15
Savings from charcoal	=12*E16	=12*E16	=12*E16	=12*E16	=12*E16
savings from Kerosene	=12*E17	=12*E17	=12*E17	=12*E17	=12*E17
Savings from Electricity	=12*E18	=12*E18	=12*E18	=12*E18	=12*E18
Savings from fertilizer	=0.1*'Basic informations'!B17*12*12	=0.1*'Basic informations'!B17*12*12	=0.1*'Basic informations'!B17*12*12	=0.1*'Basic informations'!B17*12*12	=0.1*'Basic informations'!B17*12*12
TOTAL	=SUM(E30:E35)	=SUM(F30:F35)	=SUM(G30:G35)	=SUM(H30:H35)	=SUM(I30:I35)
COSTS					
Investment	=J26				
Maintenance cost	=0.0763*E38	=0.0763*E38	=0.0763*E38	=0.0763*E38	=0.0763*E38
Operation cost	=0.1724*E38	=0.1724*E38	=0.1724*E38	=0.1724*E38	=0.1724*E38
TOTAL	=SUM(E38:E40)	=SUM(F39:F40)	=SUM(G39:G40)	=SUM(H39:H40)	=SUM(I39:I40)
NET BENEFIT	=E41-E36	=F36-F41	=G36-G41	=F36-H41	=G36-I41

Biogas System Planning for Rural Households based on Energy Demand

Economical calculations	
Source of Energy	Price
Fuel wood	=B5*G6
Dung cake	=B7*G7
Charcoal	=B6*G8
Kerosene	=B8*G9
Electricity	=G10
TOTAL	=SUM(E14:E18)

Biogas equivalents of fuels	
1 kg fire wood	0.2
1kg Charcoal	0.5
1 kg Dung cake	0.1
1 kg kerosene	1.667

Biogas System Planning for Rural Households based on Energy Demand

Initial cost (ETB)	=J26
Annual cost (ETB)	=F41
Discount rate , r	=12%
project period in years (n)	15
$(1+r)^n$	$=(1+F47)^{F48}$
$r*(1+r)^n$	$=0.12*F49$
$[(1+r)^n - 1]$	$= F49-1$
$[(1+r)^n - 1]/(r*(1+r)^n)$	$=F51/F50$
Total benefits during the lifetime of the project (Pb) ETB	$=F36*F52$
The present costs during the lifetime of the project (Pc) ETB	$=E38+ (F41*F52)$

Economic out put

Economic output		Remarks
Net Present Value (NPV) ETB	$=F53-F54$	
Annual saving (As)	$=F36-F41$	
Simple payback period (SPP) in Years	$=E38/F57$	Feasible if ≤ 3
The benefit cost ratio	$=F53/F54$	Feasible if >1

Biogas System Planning for Rural Households based on Energy Demand

Biogas demand per meal in m ³ per day	0.15
consumption rate of Gas burner m ³ /hr per flame	0.175
Gas consumption of Lamp per day m ³ /hr per day	0.12
Volatile solids(kg) per day and cattle(VS/day per cattle)	1.8
Gy,VS	0.25
Gy/cattle	0.35
organic matter get out from digester	1183.52405
