

**COMPARISON OF PRESTRESSED HOLLOW CORE SLAB AND
PRECAST CONCRETE BEAM-HCB SLAB SYSTEM**

**BY
ABEBE SHAWEL**

ADVAISOR DR-SHIFFERAW TAYE



A thesis submitted to
the School of Graduate Studies of Addis Ababa University
in partial fulfillment of the requirements for the Degree of
Master of Science in Structural Engineering

JANUARY 2008

**COMPARISON OF PRESTRESSED HOLLOW CORE SLAB
AND
PRECAST CONCRETE BEAM-HCB SLAB SYSTEM**

**BY
ABEBE SHAWEL**



**A thesis submitted to
the School of Graduate Studies of Addis Ababa University
in partial fulfillment of the requirements for the Degree of
Master of Science in Structural Engineering**

March 2008

**COMPARISON OF PRESTRESSED HOLLOW CORE
CONCRETE SLAB AND PRECAST CONCRETE
BEAM-BLOCK SLAB SYSTEM**

**BY
ABEBE SHAWEL**

ADVISOR: DR. SHIFFERAW TAYE

**A thesis submitted to
the School of Graduate Studies of Addis Ababa University
in partial fulfillment of the requirements for the Degree of
Master of Science in Structural Engineering**

March 2008

**COMPARISON OF PRESTRESSED HOLLOW CORE SLAB
AND
PRECAST CONCRETE BEAM-BLOCK SLAB SYSTEM**

**BY
ABEBE SHAWEL**



**A thesis submitted to
the School of Graduate Studies of Addis Ababa University
in partial fulfillment of the requirements for the Degree of
Master of Science in Structural Engineering**

March 2008

ACKNOWLEDGEMENT

One of the pleasures of writing this thesis is acknowledging the effort of many people whose names may not appear on the cover, but whose hard work, cooperation, friendship and understanding were crucial to the success of this project work. Therefore, I would like to take the opportunity to express my sincere gratitude to all, whom I can name out and who have highly devoted their time, knowledge and resources to the completion of this thesis.

- The Almighty **GOD**, I would like to praise for His blessings and blissfulness, He gave me to pass all these moments and finalize the paper on time as efficiently as possible.
- My Advisor, **Dr.Shifferaw Taye**, for the encouragements, guidance, critics and recommendations throughout my final year project.
- My lecturers, Dr.Ing Asnake Adamu, Dr.Ing Girma Zereyohannes and Dr.Ing Adil Zekria for their help, advices and recommendations in my two year studies. Without their continued support and interest in lectures, this thesis would not have been the same as presented here.
- My dearest colleague, Tibebe Ayele, General Manger of Kality Construction and construction Materials Production Enterprise, for giving me his bountiful cooperation and commitment all the way. He has been my mentor and alliance in gathering all the necessary information that led me actualizes my thesis.
- To my beloved & faithful Lewam and family members: Shawel, Senayet, Genet, Wogayhu, Wondewesen, and Rebica, whom had always been there to support me no matter how far or occupied they are. They had all the love and faith in me to complete my two year course in Structural Engineering.
- I would also like to thank all my friends especially Girma W. and Gediyon K. for their encouragement and supportive ideas.
- Finally to Araya H., Nausenay W., Yirgu A., Yohannes H., Temesgen A. and not to forget *my classmates* for the wonderful "*SELAM*" times we had.

I was fortunate to have been able to work on this project with a talented and dedicated people. This project happened because of the enthusiasm, persistence and professionalism of the people who revolved around me.

Abebe Shawel

Addis Ababa, March 2008

ABSTRACT

A prestressed hollow core slab element studied in this thesis is a precast prestressed concrete member with continuous voids provided to reduce weight and, therefore, cost and, as a side benefit, to use for concealed electrical or mechanical runs. Primarily used as floor or roof deck systems, hollow core slabs also have applications as wall panels, spandrel members and bridge deck units. This system of construction does not require form work and Propping during installation.

Precast, prestressed concrete floors offer significant advantages in many types of building construction. They offer design, time and cost advantages over other flooring materials and systems and are suitable for use with all structural systems, i.e. concrete, masonry and steel

In our country precast prestressed concrete elements are not widely used for construction of most buildings. The conventional cast in-situ construction require lots of formwork and construction time, and also the precast beam-slab system construction require propping and construction time too which increases the total cost of a project. When precast prestressed hollow core slab elements are introduced in vast amount in the construction of buildings, an economical construction could be achieved.

The economy of the generalized hollow core slab system is require a short construction time compared to precast beam slab system and in the quantity of slabs that can be produced at a given time with a minimum of labor required. Each slab on a given casting line will have the same number of pre-stressing strands. Therefore, the greatest production efficiency is obtained by mixing slabs with the same reinforcing requirements from several projects on a single production line. This implies that best efficiency for a single project is obtained if slab requirements are repetitive.

In the present study, the advantages of prestressed hollow core slab elements, for construction of the floor slabs of four story building, is shown by making cost comparison between the precast beam-slab system and pre-stressed hollow core slab system. For this

purpose, the same span length is chosen for the two slab systems. These elements are designed for loads they should sustain when used in the construction of slabs.

Finally cost comparison is made between the two systems of slab construction. The cost comparison showed that the prestressed hollow core slab system of construction is more economical and faster than the precast beam-slab system.

TABLE OF CONTENTS

	Page
ACKNOWLEDGMENTS	i
ABSTRACT	ii
TABLE OF CONTENTS	iv
LIST OF TABLES	vii
LIST OF FIGURES	viii
NOTATIONS	x
CHAPTER 1	
INTRODUCTION	1
1.1 General	
1.2 Objectives of the study	2
1.3 Methodology of the study	2
1.4 Application of the result	3
CHAPTER 2	
PRECAST AND PRESTRESSED CONCRETE FLOORINGS	4
2.1 General	
2.2 Precast Beam-HCB Floor Slab System	4
2.2.1 General	4
2.2.2 Description of precast beam-block slab	7
2.2.3 Precast beam and slab block installation	7
2.2.4 Benefits of precast beam-block slab system	9
2.3 Prestressed hollow core concrete floor slab	12
2.3.1 General	12
2.3.2 Description of prestressed hollow core slab	13
2.3.3 Construction of hollow core slabs	14

2.3.4 Advantages of hollow core floor slab	16
2.3.5 Diaphragm action with hollow core slabs	18
2.3.6 Connections in hollow core slabs	19
2.3.6.1 Connection details for hollow core slab system	19
CHAPTER 3	30
DESIGN OF PRECAST BEAM	
3.1 General	30
3.2 Design Guide Lines	31
3.2.1 Design load combinations	31
3.2.2 Design strength	31
3.2.3 Design moments	31
3.2.4 Flexural reinforcement	32
3.2.5 Shear reinforcement design formulas	33
3.4.2 Compression resistance of the precast beam	35
3.3 Design procedure for the precast beam element	35
3.4 Design example	38
CHAPTER 4	
DESIGN OF PRESTRESSED HOLLOW CORE CONCRETE SLAB	49
4.1 General	49
4.2 Stress limits	49
4.3 Stresses at transfer	50
4.4 Prestress losses	51
4.4.1 Immediate loss	51
4.4.2 Time dependent losses	52
4.5 Flexural capacity	53
4.5.1 Serviceability limit state of flexure	53
4.5.2 Ultimate limit state of flexure	56

4.5.2.1 Assumptions	56
4.5.2.2 Idealized rectangular compressive stress block for concrete	57
4.5.2.3 Prestresses steel strain components	57
4.5.2.4 Determination of the ultimate moment of resistance	59
4.5.2.5 Section containing non prestressed reinforcements	60
4.6 Deflection limits	63
4.7 Shear capacity	64
4.7.1 Shear capacity in the flexurally uncracked region	65
4.7.2 Shear capacity in the flexurally cracked region	66
4.8 Design guide line	67
4.8.1 General	67
4.8.2 Design procedures for the hollow core floor units	68
4.9 Design example on prestressed hollow core slab system	70
 CHAPTER 5	
COST COMPARISON	81
5.1 Construction cost component	81
5.1.1 Quantities of materials	82
5.1.1.1 Precast beam slab system	82
5.1.1.2 Hollow core floor slab	85
5.2 Construction time component	89
5.2.1 Hollow core slab System	90
5.2.2 Precast beam-slab system	91
 CHAPTER 6	
CONCLUSION AND RECOMMENDATION	93
REFERENCES	95
APPENDIX A	97
Analysis sheets for total cost determination	

DECLARATION

LIST OF TABLES

	Page
Table 3.1 Final output of precast beam design	48
Table 4.1 Summarized values for different concrete classes	82
Table 5.1 Calculation of total production cost of one precast beam elements	87
Table 5.2 Calculation of total production cost of hollow core floor slab	88
Table 5.3 Construction cost of topping in the first floor	89
Table 5.4 Construction cost of hollow core slab in the first floor	89
Table 5.5 Construction cost calculation using precast beam slab system	90
Table 5.6 Summery of cost for both precast beam-block slab and prestressed hollow core floor slab	90
Table 5.7 Pricing items for comparing the two different flooring systems	91
Table 5.8 Construction schedule using hollow core slab system	92
Table 5.9 Construction schedule using precast beam slab system	93
Table 5.10 Analysis sheet for total cost of steel reinforcements	97
Table 5.11 Analysis sheet for total cost of C-25 reinforced concrete work	98
Table 5.12 Analysis sheet for total cost of Pre cast beam installation	102
Table 5.13 Analysis sheet for total cost of slab-block installation	106
Table 5.14 Analysis sheet for total cost of prestressed wire	110
Table 5.15 Analysis sheet for total cost of C-25 reinforced concrete work for hollow core slab	111
Table 5.16 Analysis Sheet for total cost of hollow core slab installation	112
Table 5.17 Analysis Sheet for total cost of ceiling plastering for precast beam-block slab system	116
Table 5.18 Analysis Sheet for total cost of support work for precast beam-block slab system	117

LIST OF FIGURS

	Page
Figure 2.1 Typical floor slab precast beam layout	5
Figure 2.2 Elevation views of precast beam and longitudinal reinforcement	6
Figure 2.3 Cross Section of precast beam	6
Figure 2.4 Cross section of precast system after concrete casting	6
Figure 2.5 Plan, section and reinforcement at precast beam edge location	6
Figure 2.6 Plan, section and reinforcement at every precast connection.	6
Figure 2.7 The soffit of a beam and block slab in place with support	7
Figure 2.8 Typical cross section and application of precast beam slab	8
Figure 2.9 Typical hollow block for slab construction	9
Figure 2.10 Typical construction details and connections for beam and block slabs.	10
Figure 2.11 Precast beam-block slab system application procedures	11
Figure 2.12 Shear key joints between adjacent unit	12
Figure 2.13 Typical prestressed hollow core floor units in KCMPE Addis Ababa	13
Figure 2.14 Typical floor slab hollow core layout	15
Figure 2.15 Installation of hollow core floor slab	15
Figure 2.16 Hollow core slab installation procedures	16
Figure 2.17 Hollow core slabs being hoisted into position by mobile crane	18
Figure 2.18 Typical detail with concrete beams	20
Figure 2.19 Typical details with walls	27
Figure 3.1 Design of a rectangular beam section	32
Figure 3.2 Cross-section of precast beam and slab	39
Figure 4.1 Stress conditions	54
Figure 4.2 Stress blocks	57
Figure 4.3 Strains due to the effective pre-stress and at ultimate	58
Figure 4.4 Hollow core concrete floor and equivalent section	60
Figure 4.5 Section containing both tensile and compressive reinforcements	61

Figure 4.6	Shear resistances of prestressed elements	65
Figure 4.7	Cross-section of hollow core floor slab	72
Figure 4.8	Design diagram	75
Figure 4.9	Stress -strain curve	79
Figure 5.1	Use of hollow core slab on concrete framed building.	91
Figure 5.2	Network diagram of slab construction using pre stressed hollow core slab system.	92
Figure 5.3	Network diagram of slab construction using precast beam-block slab system.	93
Figure 5.4	Hollow core slabs being hoisted into position.	96

NOTATIONS

For prestressed slab design

A	cross section area
A_{ps}	area of prestressing steel
A_{sc}	area of the compressive steel
A_{st}	area of non-prestressed tensile reinforcement
b	width of the cross-section
C_c	compressive force in the concrete
C_s	compressive force in the non-prestressed steel
d_c	depth of neutral axis at ultimate
d_n	depth from the extreme compressive fiber to the neutral axis at ultimate
d_o	depth to the non-presressing tensile steel
d_s, d_p	depth to the non- prestressing and prestressed steel, respectively
D	overall depth of the cross-section
e	eccentricity of prestress
E_c	modulus of elasticity of the concrete
E_{ci}	modulus of elasticity of the concrete at transfer
E_p	modulus of elasticity of the tendons
E_s	modulus of elasticity of the non-prestressed steel
F_b	ultimate bearing stress
f_b	design ultimate bearing stress
f_{bt}	bottom fiber stress at transfer
f_{bw}	bottom fiber stress under working condition
f_{cp}	the compressive stresses at the centroidal axis due to prestress after all losses

f_{ci}	characteristic compressive strength of concrete at transfer
f_{cu}	characteristic compressive strength of concrete at 28 days
f_{ct}	compressive stress limit at transfer
f_{cw}	compressive stress limit under working service loads
f_{tt}	tensile stress limit at transfer
f_{tw}	tensile stress limit under working service loads
f_{ut}	upper fiber stress at transfer
f_{uw}	upper fiber stress under working condition
f_{pb}	design tensile stress in the tendons.
f_{pe}	design effective prestress in the tendons after all losses.
$f_{cp,x}$	design stress at a distance x from the end of member.
l_c, l_s	lever arms distance of compressive forces in the concrete and in the steel, respectively ,above the non-prestressed tensile
M_o	moment at a cross-section at transfer
M_{sus}	moment caused by the sustained load
M_T	moment caused by total service load
P_e	effective prestressing force after time-dependent losses
P_i	prestressing force immediately after transfer
P	prestressing force
P_j	prestrssing force at the jack before transfer
T_p	tension in the prestresed steel
T_s	tension in the non-prestressed steel
V	the design ultimate shear force at the section considered
V_c	the design concrete shear resistance
V_{co}	ultimate uncracked shear resistance
V_{cr}	design ultimate shear resistance of a section cracked in flexure.
W_o	uniformly distributed self weigh
Z_b, Z_t	bottom and top fiber section moduli ($I/y_b, I/y_t$) respectively

$\epsilon_c, \epsilon_c(t)$	creep strain of concrete at time t
ϵ_{cu}	ultimate compressive strain
ϵ_{cp}	the concrete strain at the level immediately after transfer
ϵ_{ce}	concrete strain at the level of the prestressed steel due to the effective prestress
ϵ_{pe}	strain in the prestressing tendon due to the effective prestress
ϵ_{pu}	the strain in the prestressing tendon at the ultimate load
ϵ_{pt}	tensile strain in the concrete at the level of prestressing tendon in the post cracking range and at the ultimate moment
$\epsilon_{sc}, \epsilon_{st}$	strain in the non-prestressed compressive and tensile steel respectively
ϵ_{sh}	shrinkage strain
ϵ_y	yield strain
δ	mid span camber or deflection
Δ	in service long-term deflection
Φ	creep coefficient
σ_{cp}	stress in the concrete at the level of the prestressing steel
σ_p, σ_s	stress in the prestressed and non-prestressed steel, respectively

For precast beam design

A_{cv}	area of section for shear resistance
A_s	area of tension reinforcement
A'_s	area of compression reinforcement,
A_{sv}	total cross-sectional area of links at the neutral axis
b_w	average web width of a flanged beam
C	compression force
d	effective depth of tension reinforcement
d'	depth to center of compression reinforcement
e_{min}	minimum or nominal eccentricity
E_c	modulus of elasticity of concrete
E_s	modulus of elasticity of reinforcement

f_{cu}	characteristic cube strength at 28 days
f'_s	compressive stress in a beam compression steel
f_y	characteristic strength of reinforcement
f_{yv}	characteristic strength of link reinforcement
K'	maximum M/bd^2f_{cu} for a singly reinforced concrete section taken as 0.156 by assuming that moment redistribution is limited to 10%
l_{33}, l_{22}	major and minor direction unbraced member lengths.
le_{33}, le_{22}	major and minor effective lengths, ($K_{33} l_{33}, K_{22} l_{22}$).
M	design moment at a section
p_c	compressive strength
P_e	euler strength
p_y	yield strength
r_{33}, r_{22}	major and minor radii of gyration
r_z	minimum radius of gyration for angles
R_{LW}	shear strength reduction factor as specified in the concrete material properties.
s_v	spacing of links
V	factored shear force at ultimate design load
v	shear stress
v_c	design ultimate shear stress resistance of a concrete beam
v'_c	design concrete shear stress corrected for axial forces
γ_f	partial safety factor for load
γ_m	partial safety factor for material strength
γ_c	partial safety factor for concrete
γ_s	partial safety factor for reinforcing steel
ϵ_c	concrete strain.
ϵ_s	strain in tension steel.
ϵ'_s	strain in compression steel.
η	perry factor.

CHAPTER 1

INTRODUCTION

1.1 GENERAL

The use of inexpensive construction system in building construction is usually associated with the question of how economical the system will be, if it is used instead of the usual or traditional ones. However, the evaluation of the economical benefits gained from using such systems requires a thorough study on the system.

Precast and prestressed concrete flooring offers an economic and versatile solution to ground and suspended floors [12]. It gives both the design and cost advantages over the most common methods of construction such as cast in-situ concrete, steel-concrete composite and timber floors [12, 20]. Approximately, half of the floors used in commercial and domestic buildings around the developed world are constructed using precast concrete floors [12].

There are various methods of precast concrete flooring construction to give the most economic solution to various types of loadings having long spans. These floors give maximum structural performance with minimum weight and can be used with or without structural toppings and non-structural finishes.

Precast prestressed hollow core concrete slab is one of the existing methods of flooring construction which has got a self weight of about one-half of a solid section of the same depth [12, 19]. It is now the most widely used type of precast flooring system in the developed and developing countries. This success is largely due to the highly efficient design and production methods, flexibility in use, surface finish and structural efficiency [1, 11, 12].

In addition precast beam elements studied in this thesis are reinforced concrete beams, in which their latticed reinforcement bars are projected out. They are used for construction of reinforced concrete slabs, in combination with hollow concrete blocks, as case of ribbed slab construction. This system of construction does not require formwork for the in-situ concrete slab.

The increasing price of building construction, Primarily due to increasing prices of building materials, and construction delays, call for inexpensive and faster methods of construction. The use of such methods of construction, especially in a developing country like Ethiopia, where there is a limited source of building materials, might be proved economical. One of such cheaper and faster method of construction is the use of precast pre-stressed hollow core elements for the construction of slabs.

Generally, the application of precast concrete floors in Ethiopia has been limited to small extent since its inception in the country. In this study an alternative method of precast concrete flooring, the precast prestressed hollow core concrete floors, is studied to come up with recommendations and conclusions for its wider application.

1.2 OBJECTIVE OF THE STUDY

The main objective of the present study is to investigate the advantage of precast prestressed hollow core concrete slab elements. This is achieved by making a cost comparison of floor slabs, analyzed and designed by the precast prestressed hollow core concrete slab system and the precast beam-block slab system. For the purpose of the cost comparison the floors of a four-story condominium building slab is analyzed and designed using both systems.

In addition, conclusions and recommendations are drawn which may be useful for further developments and the application of this system of construction.

1.3 METHODOLOGY OF THE STUDY

The following methods are employed to achieve the objectives of the research.

- Field work:

Assessment of the different plants and sites and the practice in Addis Ababa where precast and prestressed slab production and construction employed.

- Desktop works:

Literature survey on analysis and design of precast beam-block and precast prestressed hollow core concrete floors slab systems which include:

- Loading computations

- Analysis
- Detailing for various design action including connections.
- Connection practice of hollow core concrete floors with beams and walls.
- Detailed analysis and design to be followed with the design guide.
- Comparison of the slab systems

1.4 APPLICATION OF THE RESULT

The result of the thesis discloses the existence and extent of employing precast prestressed hollow core concrete floor in the country and the rational for its very small current application. This is followed by what is to be done to improve the use of the precast and prestressed concrete element technology in the country. The results of this thesis work also offer a design guideline for prestressed hollow core concrete slabs and pre cast beam for slab construction which can be used by the engineers.

CHAPTER 2

PRECAST AND PRESTRESSED CONCRETE FLOORINGS

2.1 GENERAL

Precast concrete refers to concrete components not cast in place but rather, cast off site or in a location different from their final location. Precast concrete construction represents a viable alternative to construction method utilizing cast-in-place concrete [3]. Structural elements may be precast either in a remote factory or at the job site. Precast concrete may be either ordinary reinforced or pre-stressed.

Prestressed concrete, which may be considered as a modified reinforced concrete, was not practical in general applications as late as 1933[16].surprisingly enough, however, the basic ideas of prestressed concrete were conceived almost as early as those of reinforced concrete [16].

Particular attention must be given in the design of precast and prestressed concrete units to reduction in weight and details to minimize the cost of erection and installation.

There are a wide range of flooring types available to give the most economic solution for all loading conditions and spans. These floors give maximum structural performance with minimum weight and may be used with or without structural toppings, non-structural finishes (such as tiles, granolithic screed). Some of these floors are studied and made economic comparison in chapter 5.

2.2 PRECAST BEAM-BLOCK FLOOR SLABS

2.2.1 General

A beam and block slab is composed of rectangular shaped (generally) precast concrete reinforced ribs supporting rebated filler blocks placed between two ribs. This system is sometimes referred to as plank and block or beam and block. In-situ concrete is poured between and over the blocks.

The beam and block slab system is more flexible in coping with irregular shapes. Spans are smaller and the lifting capacity required to place beams is less. It is significantly

slower than hollow core slab in construction time as in-situ concrete must be poured and cured. Propping of the system during construction is required with a beam and block system.

Precast beam elements are prefabricated reinforced concrete members having sufficient strength to carry shear and flexure. The lower portion of the reinforcement is precast, while the upper portion is exposed and yet to be casted with in-situ concrete after they are laid with hollow concrete blocks as shown in Figs 2.1 to 2.6.

During erection the precast beam elements are placed at certain intervals, say 0.6m, on already constructed beams. After the hollow concrete blocks are laid across the span of the beam elements, concrete will be casted above. Figure 2.1 shows the arrangement of precast beams in one floor slab.

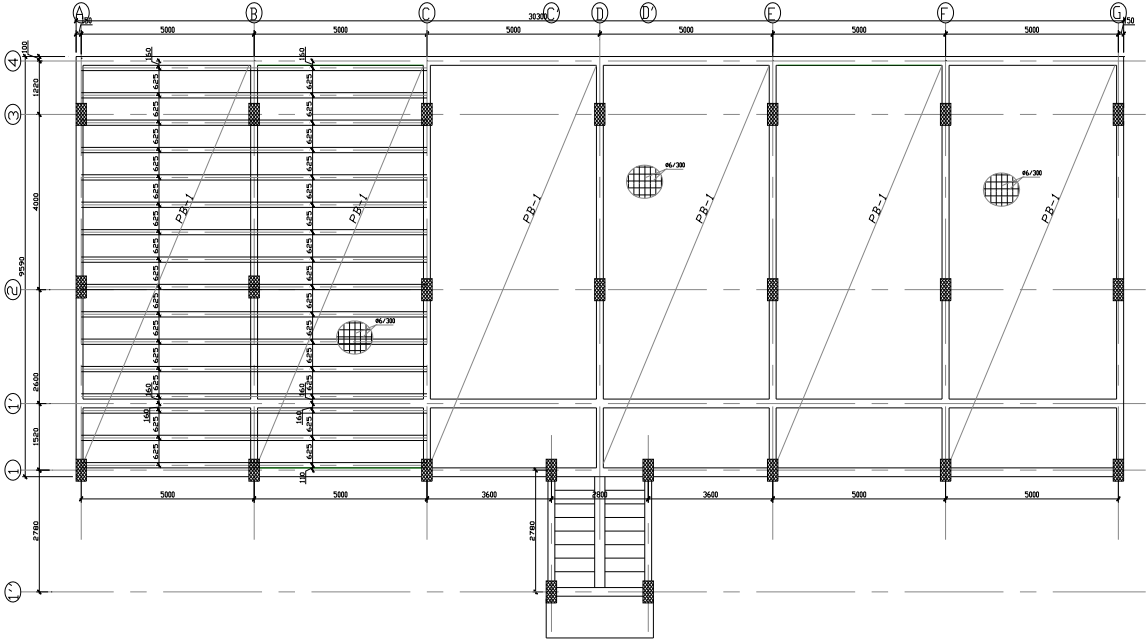

Figure 2.1 Typical floor slab precast beam layout

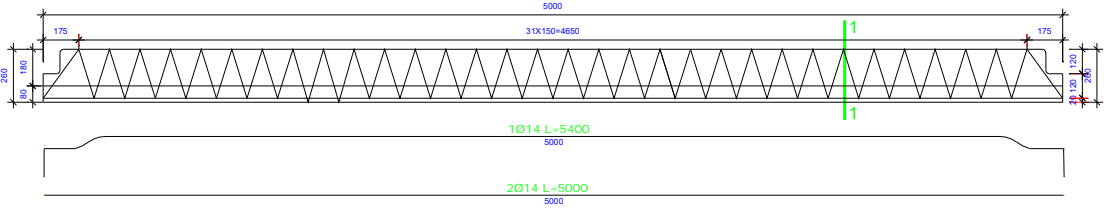

Figure 2.2 Elevation view of precast beam and longitudinal reinforcement

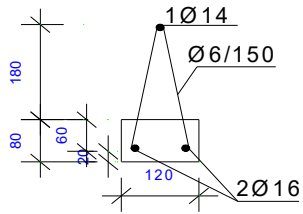

Figure 2.3 Cross section of precast beam

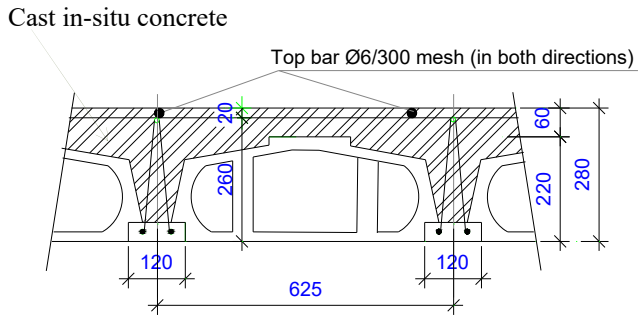

Figure 2.4 Cross section of precast beam-block system after concrete casting

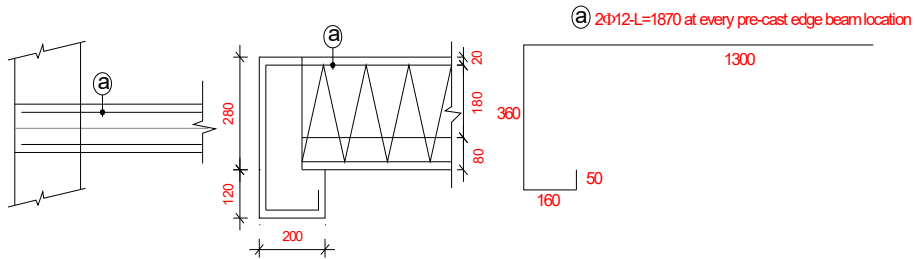

Figure 2.5 Plan, section and reinforcement at precast beam edge location.

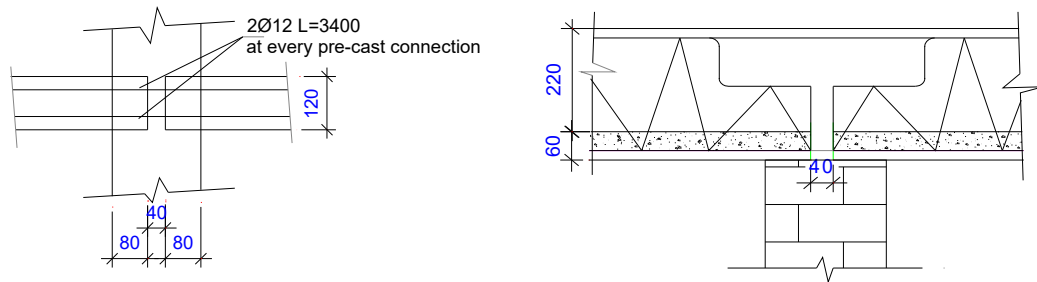

Figure 2.6 Plan, section and reinforcement at every precast connection.

2.2.2 Description of Precast Beam-Block Slab

The most common beam spacings usually used are 560, 600, 625 and 650mm. A non-structural hollow concrete rebated filler block is placed between these beams. The size of the block determines the beam spacing and provides a flush soffit. A structural concrete topping should have a minimum thickness of 50mm, or $1/10 \times$ clear distance between the beams [21]. Welded or tied mesh reinforcement is placed in this topping to control possible shrinkage cracks. The filler blocks may be produced in different heights ranging from 100 to 350mm which produces an overall depth of slab from 110 to 400mm with clear span up to 10m [21]. Beams with a width of 100 to 200mm and minimum depth 60mm are used with infill blocks 200 to 250mm long, 440 to 650mm width and 100 to 350mm deep [21].

This type of slab requires temporary supports as shown in the Fig 2.7 below at required spacing, but certain systems can also be designed to eliminate the need for props.



Figure 2.7 The soffit of a beam and block slab in place with support

2.2.3 Precast Beam and Slab Block Installation

Precast beam and hollow block Slab installation requires no mechanical aids and is manually installed using a number of skilled and non-skilled laborers. Depending on the number of crews are employed slabs can be erected at rate of up to 50 to 100m² per day per floor [25]. These precast and block Slabs are packed systematically according to layout drawings provided.

Ribs are placed on the main structural beams with a minimum bearing of 100mm as per design and drawing details at approximate centers, their position being finally adjusted

to suit the width of the filler block with a 25mm minimum bearing of block on rib. Closed end filler blocks are placed at the end of each line.

Temporary propping of beams is erected to suitable level and camber. If transverse stiffener ribs are detailed then blocks are left out to accommodate reinforcement and concrete.

After slabs have been leveled insert stiffener rib reinforcing steel as indicated by the designer. Place anti-crack weld mesh and electrical and sanitary conduits prior to pouring of structural concrete topping. Structural concrete topping to be poured in-situ over precast components. Vibrate concrete and level to finish temporary propping to be moved when concrete reaches to the required crushing strength (or according to supervising Engineers instructions).

Before concrete is cast, all rubble should be removed and the blocks thoroughly wetted. Concreting should be continuous. Removal of the temporary propping before the concrete attains acceptable compressive strength will lead to an increase in the long term deflections.

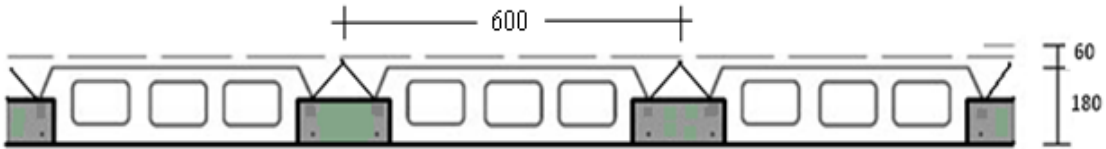

Figure 2.8 Typical cross section and application of precast beam slab

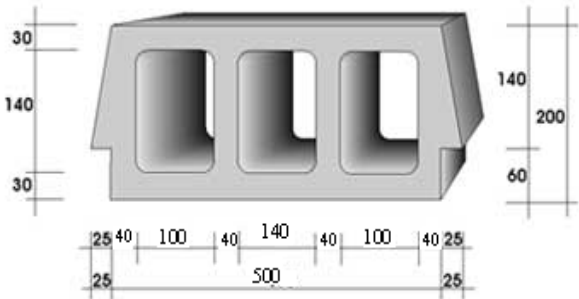

Figure 2.9 Typical hollow block for slab construction

2.2.4 Benefits of Precast Beam-Block Slab system

This modern product allows the construction market to eliminate the need for conventional cumbersome bulky in situ decking system. In addition the precast concrete and blocks reduce the amount of in-situ concrete required [7].

The relative speedy erection and completion ensures easy access to other trades and earlier occupation of completed building. Skilled laborers on site like bar benders and carpenters are reduced considerably due to the simplicity of the system and ease of handling making it ideal for the builder.

The precast beam and block slab system, eliminating the requirement for crane erection, has proven ideally suitable for commercial and industrial developments, schools, town houses, cluster homes and domestic homes.

Due to the reduction in weight over in situ slab, the beam and block system has resulted in substantial savings in the building design support structure, and the erection, thus offering the client or the investor lucrative savings towards the overall price of his development [21].

Some of the detailed advantages of precast beam and block slab system are

- Precast slabs can be erected a lot quicker than in-situ slabs.
- Reduced erection time and labor cost over conventional reinforced concrete slabs
- Excellent structural integrity (monolithic slab)
- They are ideal for soffit plaster but fixing of suspended ceilings are also easy and simple
- It provides an economical, versatile light weight monolithic slab system. Components are relatively light and no mechanical handling is necessary but needs a number of skilled and non skilled labors.
- Non-highly skilled labor required for installation
- No formwork but needs propping
- Factory controlled superlative quality
- Relatively Lightweight structure
- Fast, flexible and cost effective

- Minimal site access required

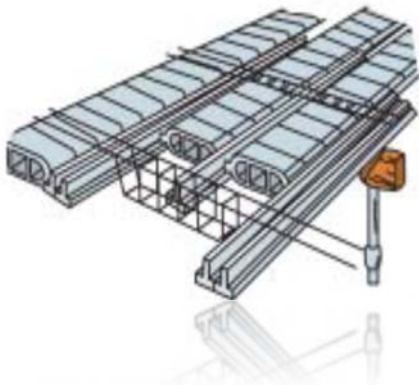
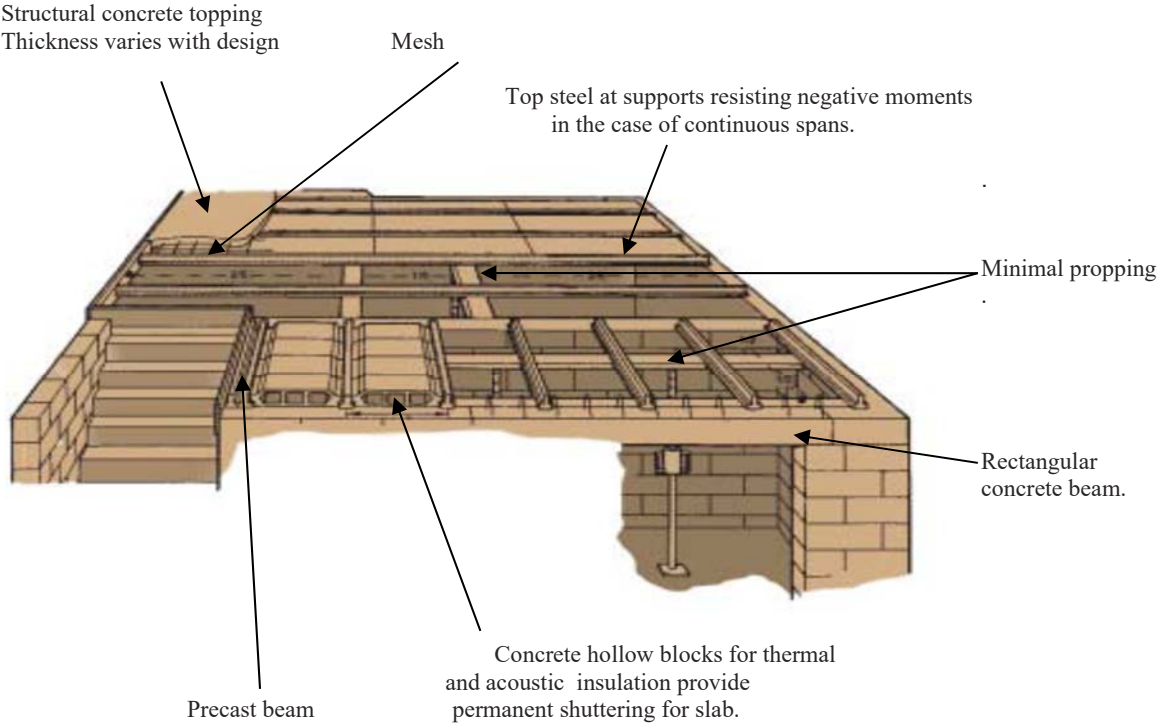

Figure 2.10 Typical construction details and connections for beam and block slabs



(a) Precast beam installation



(b) Setting out of hollow blocks



(c) Hollow block installation



(d) Propping under indicated positions



(e) Mesh placed over blocks



(f) Sanitary and electric conduits Installation



(g) Casting concrete



Figure 2.11 Precast beam-block slab system application procedures

2.3 Prestressed Hollow Core Concrete Floor Slab

2.3.1 General

A hollow core slab is a precast prestressed concrete member with continuous voids provided to reduce weight and, therefore, cost and, as a side benefit, to use for concealed electrical or mechanical runs. Primarily used as floor or roof deck systems, hollow core slabs also have applications as wall panels, spandrel members and bridge deck units. These kinds of floors have roughly a self weight equal to half of a solid section of the same depth [12, 19]. Most common depths range from 150 to 300mm and most common widths range from 600 to 1200mm [12, 22, 24].

Hollow core units, which were developed around 1950s, can be used without any structural topping [12]. This is because the slab is designed to have effective shear key joints between adjacent units such that when grouted the individual slabs become a system that behaves similar to a monolithic slab standard edge profiles have evolved to ensure an adequate transfer of horizontal and vertical shear between adjacent units [7, 12]. Mostly, these kinds of floor units are one-way spans which are simply supported and are also prestressed.

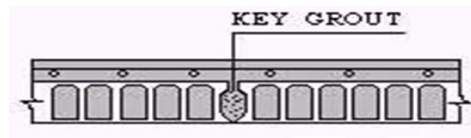

Figure 2.12 Shear key joints between adjacent unit

The hollow core slab is manufactured in the quality-controlled conditions of a small to large scale factory and the only site work involved is the placing of a leveling screed 30 to 45mm thick. Hollow core slab fitting into non-modular widths (module normally 600mm, 900mm or 1200mm) are cut to size in the factory while concrete is fresh. They are cut to length to suit as built building dimensions immediately after the concrete has reached the required strength. Propping is usually not required on hollow core slabs and following trades can start work immediately after erection [21].

2.3.2 Description of Prestressed Hollow Core Slab

Cores are typically either circular or elliptical. Slabs may be reinforced or prestressed. The hollow cores afford a reduction in self weight of 30% or more compared with a solid slab of the same depth. For most applications, no propping is necessary during construction, but crane access is essential. An erection rate of up to 600m² per day per floor is possible [21].

The longitudinal edges of the precast prestressed concrete core slab units are designed and profiled to receive grout in the joints and create a shear interlock which provides load transfer and prevents differential deflection. The top surface is generally prepared to receive a floor finish, screed or structural topping, because they are cast against a steel surface, the soffits are smooth and ready to receive a decorating finish direct without the need for plastering.

Depending on the loading do not necessarily need structural topping, although a leveling screed is required. Prestressed hollow core slabs are manufactured in units 900mm or 1200mm wide with depths of 120,150, 200,240 and 260mm. Units are made in lengths up to 12m [21]. The number and disposition of prestressing tendons varies according to span and loading [21].



Figure 2.13 Typical prestressed hollow core concrete floor units produced in KCMPE Addis Ababa

2.3.3 Construction Methodology for Hollow Core Slabs

Hollow core slabs are manufactured to suit the as built dimensions of the building. They are delivered to the site on the day that they are required to be erected onto the building. a crane is required to place the slabs into position directly from the delivery truck and or from the site storage area. Tower cranes give maximum reach but on normal 2, 3 and 4 storey buildings mobile cranes are used. They have a lifting capacity of 30 tones with a 31m boom, and operate easily over a 17m radius. With hollow core slab the placing of 600m² to 700m² of finished floor area per shift can be achieved [7].

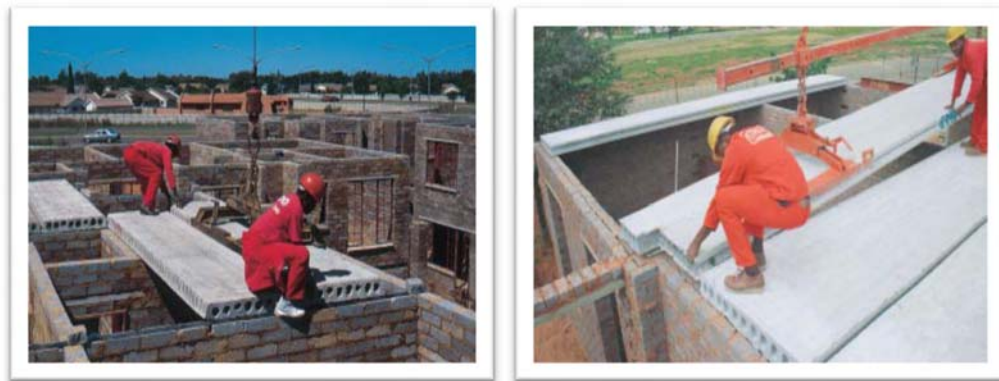

(a) Hollow core slab for a townhouse complex

(b) Erection of hollow core slab

Figure 2.14 Installation of hollow core floor slab

Slabs are placed on the structural beams or masonry walls with a minimum bearing of 100mm as per design and drawing details which considering lateral displacement of the structures. On roofs or exposed balconies, install the specified material to accommodate thermal movement (e.g. bituminized soft board or similar). Such provision must make allowance for changes in camber or deflection, particularly where light parapet walls are built on prestressed HCS. In such situations light mesh reinforcement should also be placed in the finishing screed or topping.

Hollow core slabs cast on concrete soffits are suitable for decoration direct. The joints are featured unless the whole surface is plastered with a thin-coat plaster. Before plastering, a bonding agent should be applied to the slab surface and a light mesh must be placed in the leveling screed on top of the slab.

Whenever hollow core slabs are used on an exposed balcony or walkway, or on a roof, light mesh reinforcement should be incorporated in the finishing screed or topping over all joints.

The same applies in any situation where ceramic tiles are to be used. Regular expansion joints must be allowed for large areas. As with all concrete roofs, the finished roof surface should be light-colored and reflective, with thermal insulation provided to reduce slab movement. In addition the executer should have river sand and cement available close to the building on which the slabs are to be erected so that the floor manufacturer's grouting team can mix up a suitable grout mix and lay it in the joints between the flooring units as shown in the Fig.2.16c below.

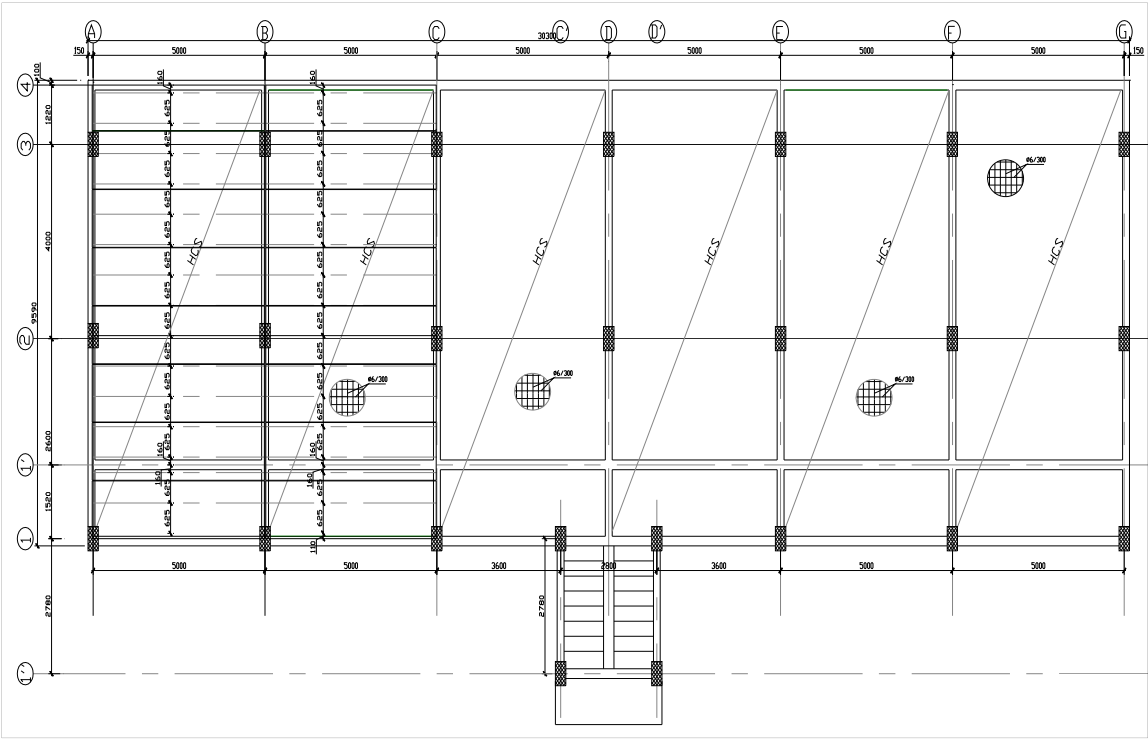

Figure 2.15 Typical floor slab hollow core layout



a) Transporting of hollow core slab



(b) Hoisting hollow core slabs into position



(c) Precast hollow core slabs erected on in-situ beams



(d) Grouting joint between hollow core slabs

Figure 2.16 Hollow core slab installation procedures

2.3.4 Advantages of Hollow Core Floor Slab

Hollow core slabs are most widely known for providing economical, efficient floor and roof systems [21]. The top surface can be prepared for the installation of a floor covering by feathering the joints with latex cement, installing non-structural fill concretes ranging from 15 to 50mm thick depending on the material used, or by casting a composite structural concrete topping. The underside can be used as a finished ceiling as installed, by painting, or by applying an acoustical spray [7].

When properly coordinated for alignment, the voids in a hollow core slab may be used for electrical or mechanical runs. For example, routing of a lighting circuit through the cores can allow fixtures in an exposed slab ceiling without unsightly surface mounted conduit. A hollow core slab provides the efficiency of a prestressed member for load capacity, span range, and deflection control. In addition, a basic diaphragm is provided for

resisting lateral loads by the grouted slab assembly provided proper connections and details exist [7].

The main advantages of the hollow core floor slab can be summarized as follows:-

It reduces the total dead load of the building as it provides us a smaller cross sectional dimension, compared with other floor systems [7]. The slab itself can carry live load without any temporary support during construction providing us with suitable working conditions.

- Speed of erection

Time consuming activities such as propping, shuttering and concrete pouring are virtually eliminated.

- Immediate un-propped working platform

Propping is generally not required with hollow core floors. Once a precast hollow core floor is erected it is immediately available as a working platform.

- Minimum in-situ concrete

Using a precast hollow core floor, a relative large volume of work is carried out off site; this reduces what can be a complex and a time consuming site operation that is subjected to different types of climate conditions.

- Extra long spans

Factory made prestressed units offer the maximum design advantages of achieving long span units for a given depth. This avoids the need for intermediate supports.

- Diaphragm action

Precast prestressed hollow core floor slabs, when structurally grouted; provide a floor with full diaphragm action to the building. A structural concrete topping is not required [20].

- Structural efficiency

A hollow core slab offers the ideal structural section by reducing the dead weight whilst providing the maximum structural efficiency within the slab depth [20].

- Factory produced to rigorous quality standards

Because precast floors are factory produced, they are manufactured in an environment which is more controlled than a building site. Quality control systems are properly

implemented and are independently examined on a regular basis, under the standards institution quality.



Figure 2.17 Hollow core slabs being hoisted into position by mobile crane

2.3.5 Diaphragm Action with Hollow Core Slabs

When hollow core slabs are used as floor or roof decks to support vertical loads, the natural extension is to use the slabs as a diaphragm to resist and transmit lateral loads. Lateral loads will be applied to building structures in the form of lateral earth pressures, wind loads or seismic loads.

The function of a diaphragm is to receive these lateral loads from the building elements to which they have been applied and transmit the loads to the lateral-resisting elements which carry the lateral loads to the foundation. The design issues in a hollow core diaphragm are the design of connections to get loads into the diaphragm, the strength and ductility of the slab system to transmit these loads to the lateral-resisting elements and the design of the connections required to unload the lateral forces from the diaphragm to the lateral-resisting elements [7].

If any design responsibility will be delegated to the hollow core supplier, the location and magnitude of the lateral loads applied to the diaphragm and the location and magnitude of forces to be transmitted to lateral-resisting elements must be specified. Where hollow core slabs must connect to other building materials or where demands on connections go beyond simple strength demands, the connection details should be shown in Section 2.3.6.1.

2.3.6 Connections in Hollow Core Slabs

Connections will be required in hollow core slab systems for a wide variety of reasons. Most connection requirements will be for localized forces ranging from bracing a partition or beam to hanging a ceiling [7].

Connections are an expense to a project and, if used improperly, may have detrimental effects by not accommodating volume change movements that occur in a precast structure. Connections may develop forces as they restrain these movements.

In specifying connection requirements, the actual forces in the connection must be addressed. If no force can be shown to exist, the connection should not be used. Again, cost is reduced and undesirable restraining forces will not be developed.

2.3.6.1 Connection details for hollow core slab system

Common details are shown in Figs 2.19 and 2.20 to cover a number of conditions where forces will probably exist that need to be transmitted into or through a hollow core slab. The conditions cover common detailing situations when hollow core slabs are used. The commentary provided with each detail is intended to give a better understanding of the merits of each detail. The emphasis is that these provide a guide which can be used as a basis for better discussions with designers and local producers. The details are only conceptual and would require detailed information to be used on a project [7]. Different types of connection details, with their description are given in Tables 2.19 and 2.20.

<p>Design considerations Can transfer internal diaphragm forces</p> <ul style="list-style-type: none"> • Can be designed as structural integrity tie <p>Fabrication considerations</p> <ul style="list-style-type: none"> • Advantageous to have no hardware in slab • Beam embodiments' must line up with slab joints • Accommodates variations in slab length <p>Erection considerations</p> <ul style="list-style-type: none"> • Advantageous to have connection completed by follow-up crew • Difficult for welder to hold loose plate in position 	 <p>Labels in diagram: L with headed stud anchors, Plate with deformed bar grouted in slab keyway, With return, Topping if required, Bearing strip, P.C. or C.I.P. concrete beam.</p>
<p>Design considerations</p> <ul style="list-style-type: none"> • Can transfer internal diaphragm forces • Can be designed as structural integrity tie <p>Fabrication considerations</p> <ul style="list-style-type: none"> • May increase beam reinforcement For shallower beam • Layout must have opposing slab joints lined up <p>Erection considerations</p> <ul style="list-style-type: none"> • Clean and simple 	 <p>Labels in diagram: Reinforcement grouted in slab keyway, Grout, Topping if required, Bearing strip, P.C. or C.I.P. concrete beam.</p>

Figure 2.18 Typical details with concrete beams

<p>Design considerations</p> <ul style="list-style-type: none"> • With large factors of safety, friction may transfer nominal forces • Additional structural integrity ties may be required <p>Fabrication considerations</p> <ul style="list-style-type: none"> • Clean and simple <p>Erection considerations</p> <ul style="list-style-type: none"> • Clean and simple 	
<p>Design considerations</p> <ul style="list-style-type: none"> • Can transfer internal diaphragm forces • Can be designed as structural integrity tie • Consider concrete cover on reinforcement over beam <p>Fabrication considerations</p> <ul style="list-style-type: none"> • Slab layout must have opposing joints lined up <p>Erection considerations</p> <ul style="list-style-type: none"> • Clean and simple 	

Fig 2.18 Typical.....

(Cont'd)

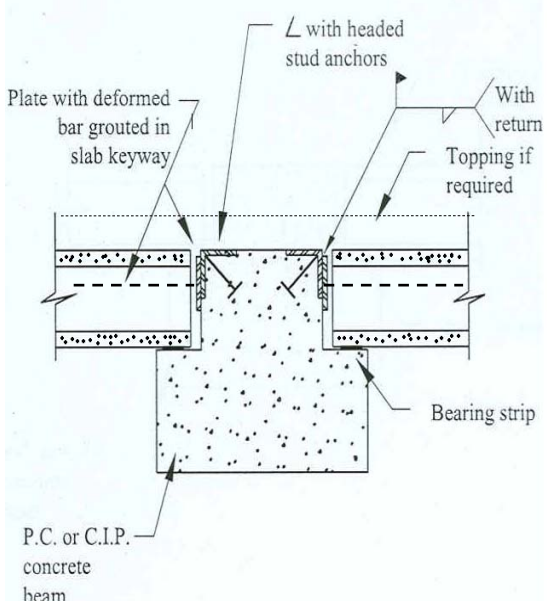
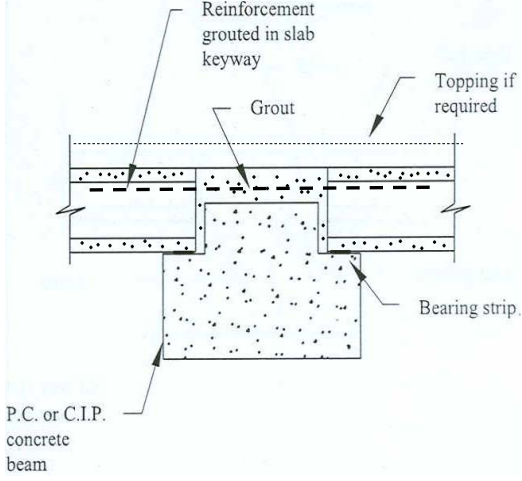
<p>Design considerations</p> <ul style="list-style-type: none"> • Can transfer internal diaphragm forces • Can be designed as structural Integrity tie • Horizontal shear in composite beam must be transferred • Opposing slab joints must line up <p>Fabrication considerations</p> <ul style="list-style-type: none"> • Clean and simple for slabs <p>Erection considerations</p> <ul style="list-style-type: none"> • Beam may have to be shored until topping is cured • Horizontal shear reinforcement may present safety hazard for erector • Core dams must be placed 	<p>Reinforcement grouted in slab keyway</p> <p>Reinforcement per design</p> <p>Topping</p> <p>Dam cores</p> <p>Bearing strip</p> <p>P.C. or C.I.P. concrete beam</p>
<p>Design considerations</p> <ul style="list-style-type: none"> • Can transfer diaphragm shear • Can provide lateral brace for beam • Potential for negative moment in Slabs <p>Fabrication considerations</p> <ul style="list-style-type: none"> • Slab insert difficult to install. Because of tolerance on saw cut ends, the insert should be installed after slabs are cut to length • Beam and slab inserts must align <p>Erection considerations</p> <ul style="list-style-type: none"> • If required for lateral beam stability, welding may have to be completed as slabs are set 	<p>Plate as required by design</p> <p>L with headed stud anchors or deformed bar</p> <p>Topping if required</p> <p>L with headed stud anchors</p> <p>Bearing strip</p> <p>P.C. or C.I.P. concrete beam</p>

Fig 2.18 Typical.....

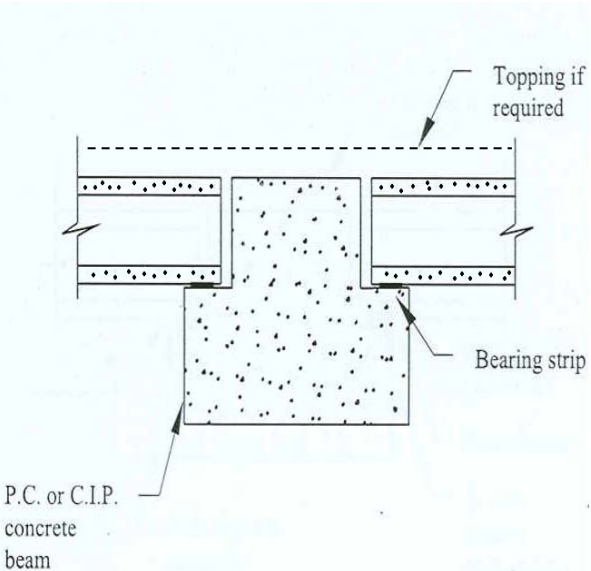
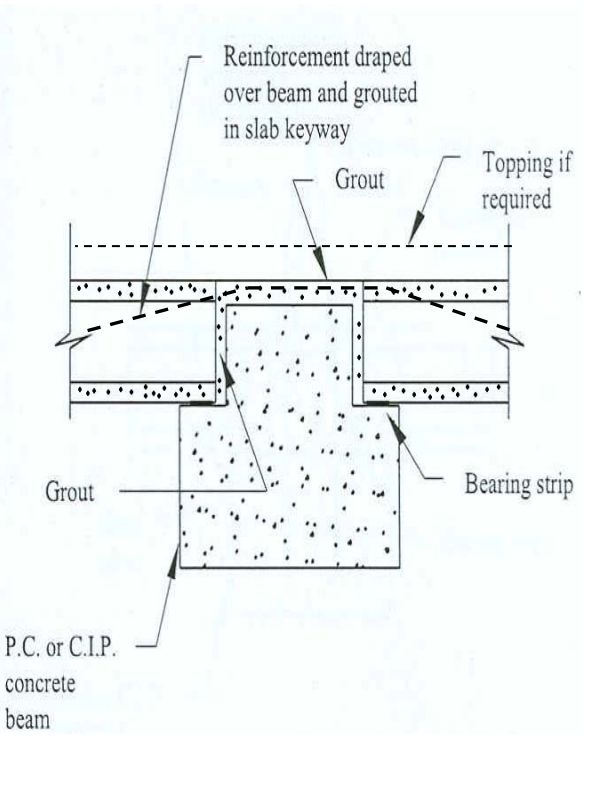
(Cont'd)

<p>Design considerations</p> <ul style="list-style-type: none"> • Can transfer internal diaphragm forces • Can be designed as structural integrity tie • Horizontal shear in composite beam must be transferred • Opposing slab joints must line up <p>Fabrication considerations</p> <ul style="list-style-type: none"> • Clean and simple for slabs <p>Erection considerations</p> <ul style="list-style-type: none"> • Beam may have to be shored until topping is cured • Horizontal shear reinforcement may present safety hazard for erector • Core dams must be placed 	 <p>Reinforcement grouted in slab keyway</p> <p>Reinforcement per design</p> <p>Topping</p> <p>Dam cores</p> <p>Bearing strip</p> <p>P.C. or C.I.P. concrete beam</p>
<p>Design considerations</p> <ul style="list-style-type: none"> • Can transfer diaphragm shear • Can provide lateral brace for beam • Potential for negative moment in slabs <p>Fabrication considerations</p> <ul style="list-style-type: none"> • Slab insert difficult to install. Because of tolerance on saw cut ends, the insert should be installed after slabs are cut to length • Beam and slab inserts must align <p>Erection considerations</p> <ul style="list-style-type: none"> • If required for lateral beam stability, welding may have to be completed as slabs are set 	 <p>Plate as required by design</p> <p>L with headed stud anchors or deformed bar</p> <p>Topping if required</p> <p>L with headed stud anchors</p> <p>Bearing strip</p> <p>P.C. or C.I.P. concrete beam</p>

Fig 2.18 Typical.....

(Cont'd)

<p>Design considerations</p> <ul style="list-style-type: none"> • Can transfer diaphragm shear • Can provide lateral brace for beam • Potential to develop negative moment in slabs <p>Erection considerations</p> <ul style="list-style-type: none"> • Connection can be completed with a follow-up crew • Lateral bracing for beam will not be provided until keyway grout cures <p>Fabrication considerations</p> <ul style="list-style-type: none"> • Plates in beam must align with slab joints allowing tolerance 	 <p>Diagram illustrating a beam-slab connection. A concrete beam (P.C. or C.I.P.) is shown below a slab. A bearing strip is placed between the beam and the slab. A plate with deformed bar anchor is grouted in the slab keyway. A plate with headed stud anchors is attached to the top of the beam. Topping is shown above the slab, with a note 'Topping if required'.</p>
<p>Design considerations</p> <ul style="list-style-type: none"> • Can transfer internal diaphragm forces • Can be designed as structural integrity tie <p>Fabrication considerations</p> <ul style="list-style-type: none"> • Clean and simple <p>Erection considerations</p> <ul style="list-style-type: none"> • Clean and simple • Keyway dimensions may limit the reinforcement diameter 	 <p>Diagram illustrating a beam-slab connection. A concrete beam (P.C. or C.I.P.) is shown below a slab. A bearing strip is placed between the beam and the slab. Reinforcement is grouted in the slab keyway. Topping is shown above the slab, with a note 'Topping if required'.</p>

Fig 2.18 Typical.....

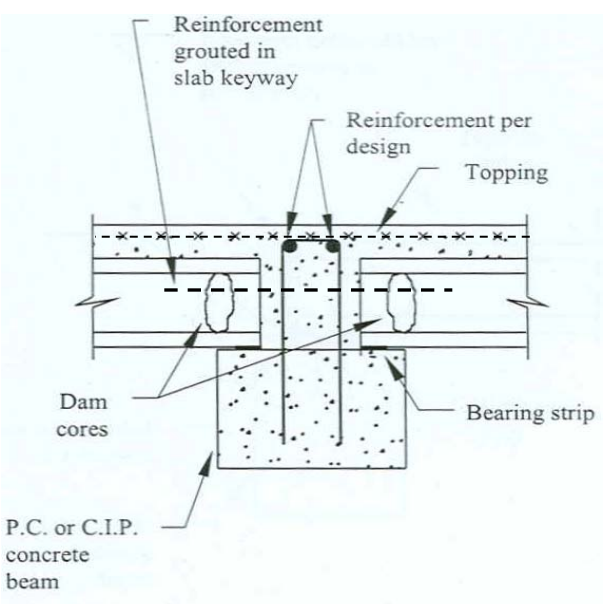
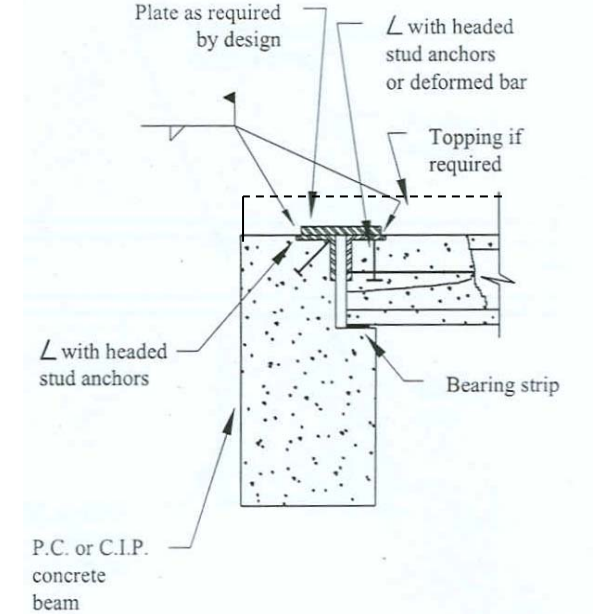
(Cont'd)

<p>Design considerations</p> <ul style="list-style-type: none"> • Can transfer diaphragm shear • Can be designed as structural integrity tie <p>Fabrication considerations</p> <ul style="list-style-type: none"> • Clean and simple for both beam and Slabs <p>Erection considerations</p> <ul style="list-style-type: none"> • Reinforcement must be tied in place • Concrete must be cast around reinforcement • Edge form is required for cast-in-place concrete • Dowels from beam may present safety hazard 	 <p>Reinforcement grouted in slab keyway</p> <p>Longitudinal bar as req'd.</p> <p>Topping if required</p> <p>Bearing strip</p> <p>P.C. or C.I.P. concrete beam</p>
<p>Design considerations</p> <ul style="list-style-type: none"> • Can transfer internal diaphragm forces • Will develop volume change restraint forces that must be considered in design of connection <p>Fabrication considerations</p> <ul style="list-style-type: none"> • Slab manufacturing system must allow bottom weld inserts • Beam and slab inserts must align with allowance for tolerance <p>Erection considerations</p> <ul style="list-style-type: none"> • Connections can be completed by follow-up crew • Access for welding may require ladders or scaffold • Spacer may be required to make weld 	 <p>Weld Plate (alt. ends)</p> <p>Topping if required</p> <p>Bearing strip</p> <p>L with headed stud anchor</p> <p>P.C. or C.I.P. concrete beam</p>

Fig 2.18 Typical.....

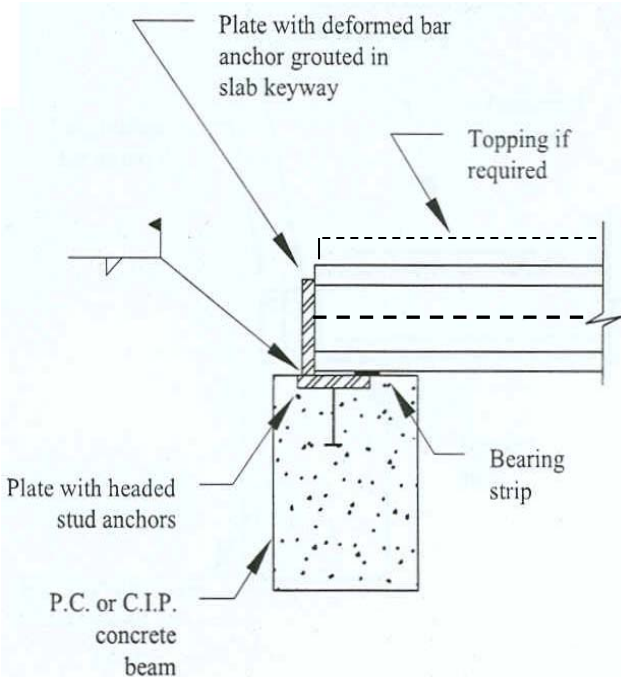
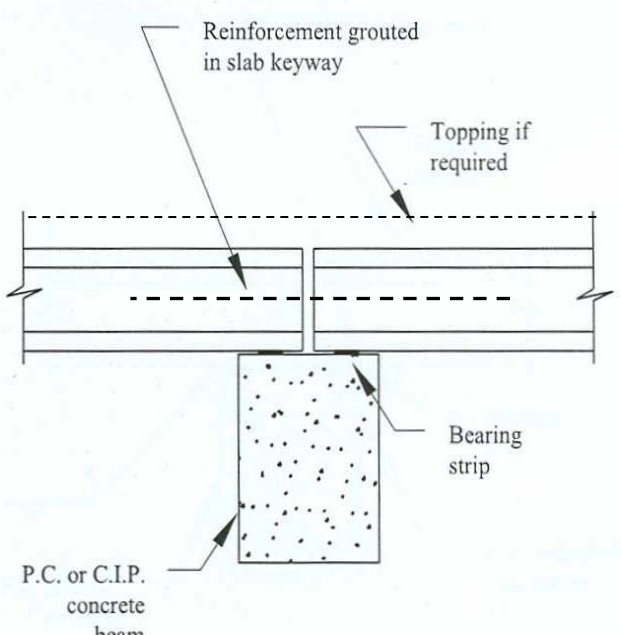
(Cont'd)

Design considerations

- Can transfer diaphragm shear
- Tensional and lateral beam restraint can be provided
- Will develop volume change restraint forces that must be considered in design of connection

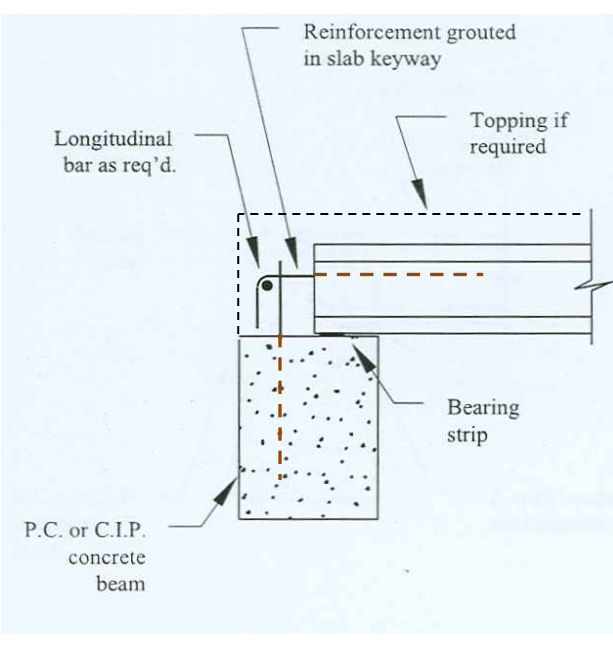
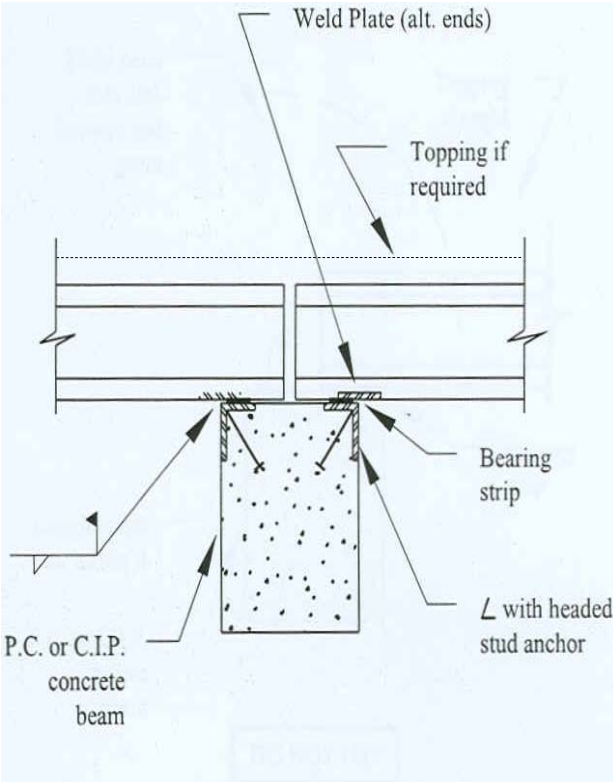
Fabrication considerations

- Slab manufacturing system must allow bottom weld inserts
- Beam and slab weld anchors must align

With allowances for tolerance

Erection considerations

- Connections can be completed by follow up crew
- Access for welding may require ladders or scaffold
- Spacer may be required to make weld

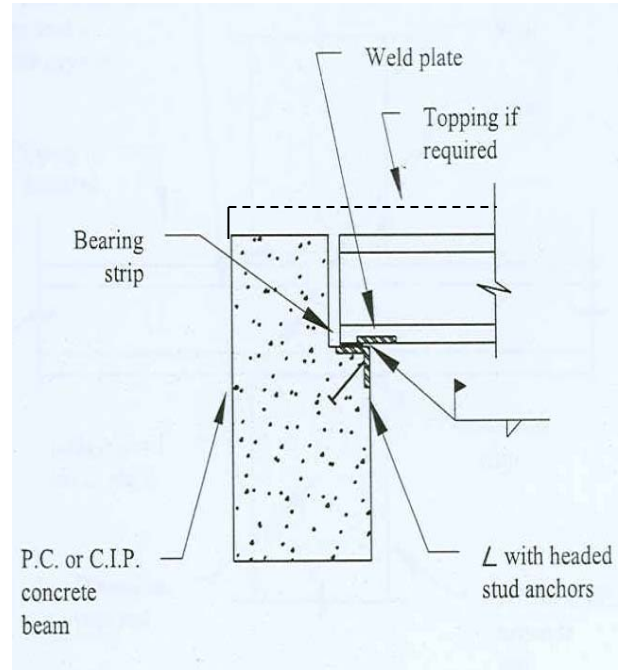

Fig 2.18 Typical.....

(Cont'd)

<p>Design considerations:</p> <ul style="list-style-type: none"> • Can transfer diaphragm shear • Can be designed as structural integrity tie • Can provide lateral brace for wall • Consider axial force path through slab ends • Opposing slab joints must line up <p>Fabrication considerations:</p> <ul style="list-style-type: none"> • Clean and simple for slabs • Small tolerance for placement of bars in walls • Tolerance on length of slabs to accommodate bars in joint <p>Erection considerations:</p> <ul style="list-style-type: none"> • With longitudinal bar, have potential congestion • Slab erection must consider tight tolerance on butt joint gap • With precast walls, consider method of installing vertical dowel 	
<p>Design considerations</p> <ul style="list-style-type: none"> • Can transfer diaphragm shear • Can be designed as structural integrity tie • Can provide lateral brace for wall • Opposing slab joints must line up <p>Fabrication considerations</p> <ul style="list-style-type: none"> • Clean and simple for slabs <p>Erection considerations</p> <ul style="list-style-type: none"> • Clean and simple • Wall is not braced until grout is placed and cured 	

Figure 2.19 Typical details with walls

<p>Design considerations:</p> <ul style="list-style-type: none"> • Can transfer diaphragm shear • Can provide lateral brace for wall with proper detailing • Consideration should be given to forces developed as slab ends rotate <p>Erection considerations:</p> <ul style="list-style-type: none"> • Simple for slab erection • The mason can set bars independent of the slab joints • Grout at slab end may be difficult to place <p>Fabrication considerations:</p> <ul style="list-style-type: none"> • Clean and simple 	
<p>Design Considerations</p> <ul style="list-style-type: none"> • Can transfer diaphragm shear • Can provide lateral brace for wall with proper bar detailing • Consideration should be given to forces developed as slab ends rotate <p>Fabrication Considerations</p> <ul style="list-style-type: none"> • Clean and simple <p>Erection Considerations</p> <ul style="list-style-type: none"> • Simple for slab erection • The mason can set bars independent of the slab joints • Some block cutting may be required for bars from keyway 	

Figure 2.19 Typical....

(Cont'd)

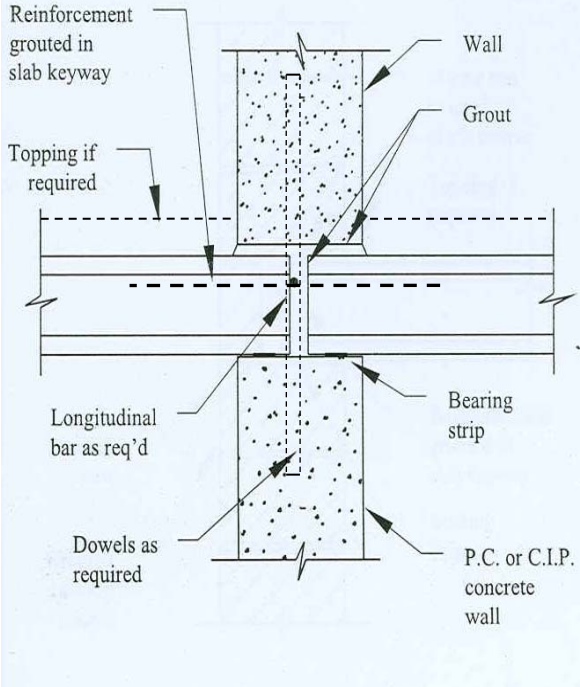
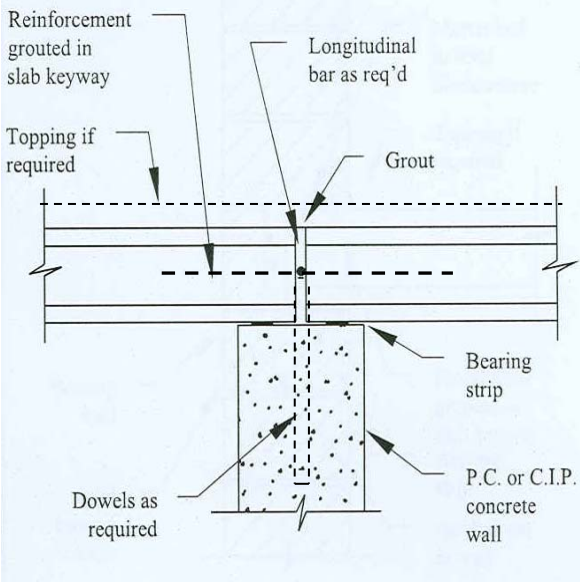
<p>Design considerations:</p> <ul style="list-style-type: none"> • Can transfer diaphragm shear • Can provide lateral brace for wall with proper detailing • Consideration should be given to forces developed as slab ends rotate <p>Erection considerations:</p> <ul style="list-style-type: none"> • Simple for slab erection • The mason can set bars independent of the slab joints • Grout at slab end may be difficult to place <p>Fabrication considerations:</p> <ul style="list-style-type: none"> • Clean and simple 	
<p>Design Considerations</p> <ul style="list-style-type: none"> • Can transfer diaphragm shear • Can provide lateral brace for wall • Consideration should be given to forces developed from deflection or camber growth • Consider axial load path <p>Fabrication Considerations</p> <ul style="list-style-type: none"> • If not done in field, slots and holes must be cut for steel • In stack casting system slots and holes might not be practically cut in plan <p>Erection Considerations</p> <ul style="list-style-type: none"> • Allowance must be made for slab camber • If not done in plant, holes and slots must be cut for steel • Wall is not braced until steel is grouted 	

Figure 2.19 Typical....

(Cont'd)

CHAPTER 3

DESIGN OF PRECAST BEAM

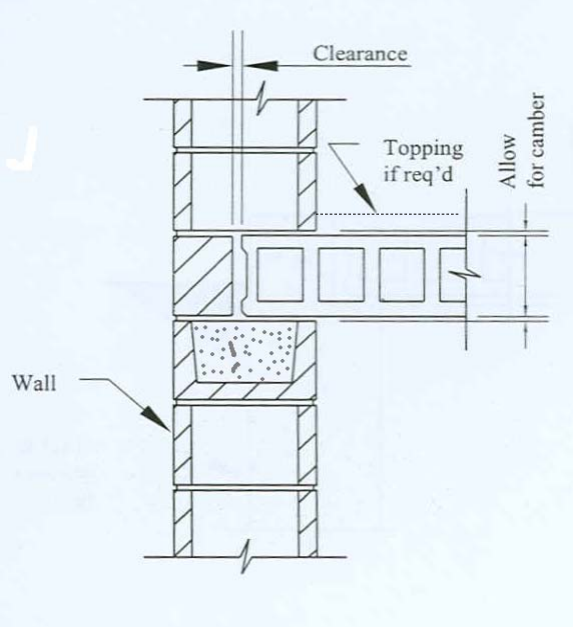
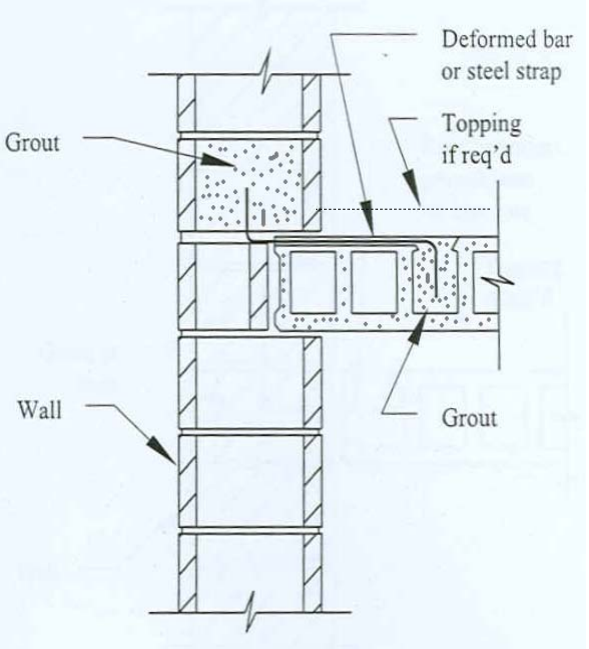
3.1 GENERAL

Precast beam-block slab system in this study, is a system of slab construction in which reinforced concrete precast beam elements, with their latticed reinforcement bars projected out, are used. During construction, these beam elements will be placed at certain intervals, to accommodate hollow concrete blocks. These blocks of specified dimensions are placed along these prefabricate beams and across the span of these elements in a similar fashion as in the case of ribbed slab construction. Concrete will then be casted above the blocks and the beam elements.

The projected reinforcement bar from the beam elements are used as an anchorage for the concrete, in addition to their main purpose, i.e. shear resistance. The beam elements, together with the blocks, act as formwork for the concrete casted. In addition, the beam elements will act as flexural members to carry the loads until the cast in-situ concrete attains its full strength.

In the design of precast concrete beams, the required areas of steel for flexure and shear shall be calculated based upon the beam moments, and shears, load combination factors, and other criteria described herein. The reinforcement requirements are calculated at a user-defined number of check stations along the precast beam span.

The precast beam design procedure involves the following steps:

- Design of precast beam flexural reinforcement based on initial condition
- Design of precast beam flexural reinforcement based on final condition
- Design of precast beam shear reinforcement

Finally the governing reinforcement requirement shall be provided.

3.2 DESIGN GUIDE LINE

3.2.1 Design Load Combinations

The design load combinations define the various factored combinations of the load cases for which the structure is to be checked. The design load combinations are obtained by multiplying the characteristic loads by appropriate partial factors of safety, γ_f [4]. If a structure is subjected to dead load (DL) and live load (LL) only, the design will need only one loading combination, the following load combination for ultimate limit state might need to be considered for the design of precast beams [4].

$$\text{LC} = 1.4 \text{ DL} + 1.6 \text{ LL} \quad 3.1$$

where, LC denotes load combination

3.2.2 Design Strength

The design strength for concrete and steel are obtained by dividing the characteristic strength of the material by a partial factor of safety, γ_m [4]. The values of γ_m used in the design are listed below

$$\gamma_m = \begin{cases} 1.05 & \text{for reinforcement,} \\ 1.50 & \text{for concrete in flexure and axial load, and} \\ 1.25 & \text{for shear strength without shear reinforcement.} \end{cases} \quad 3.2$$

3.2.3 Design Moments

In the design of flexural reinforcement of precast concrete beams, the factored loads for each load combination are obtained by factoring the corresponding loads for different load cases with the corresponding load factors. The design moment is then calculated at the critical beam section for the design of flexural reinforcement.

3.2.4 Flexural Reinforcement

The beam top and bottom flexural steel areas are designed at a user defined number of check stations along the beam span. The following steps are involved in designing the flexural reinforcement for the major moment for a particular beam at a particular section:

- Determine the maximum factored moments
- Determine the reinforcing steel

In the flexural reinforcement design process, both the tension and compression reinforcement are to be calculated. Compression reinforcement is added when the applied design moment exceeds the maximum moment capacity of a singly reinforced section. The designer has the option of avoiding the compression reinforcement by increasing the effective depth, the width, or the grade of concrete.

The design procedure is based on the simplified rectangular stress block as shown in Fig 3.1. It is assumed that moment redistribution in the member does not exceed 10% (i.e., $\beta_b \geq 0.9$). The code also places a limitation on the neutral axis depth, $x/d \leq 0.5$, to safeguard against ductile failures [4]. In addition, the area of compression reinforcement is calculated assuming that the neutral axis depth remains at the maximum permitted value.

For rectangular beams, the moment capacity as a singly reinforced beam, M_{single} , is obtained first for a section. The reinforcing steel area is determined based on whether M is greater than, less than, or equal to M_{single} .

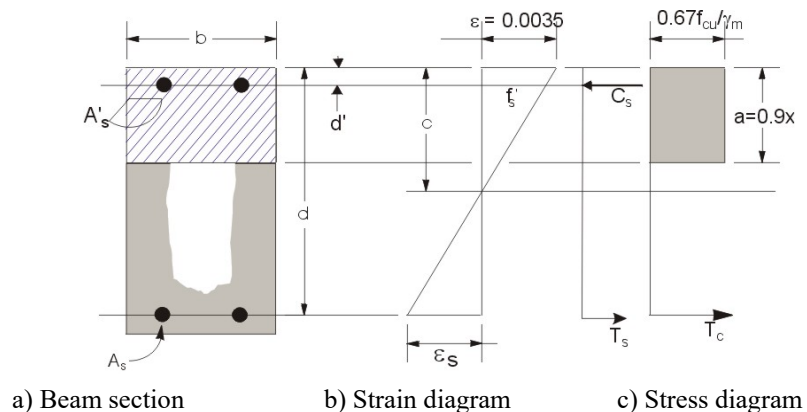

Figure 3.1 Design of a rectangular beam section

- Calculate the ultimate moment of resistance of the section as a singly reinforced beam

$$M_{\text{single}} = K' f_{cu} b d^2 \quad 3.3$$

where $K' = 0.156$

- If $M \leq M_{\text{single}}$, no compression reinforcement is required. The area of tension reinforcement, A_s , is obtained from

$$A_s = \frac{M}{(0.95 f_y) Z} \quad 3.4$$

where

$$Z = d \left(0.5 + \sqrt{0.25 - \frac{K}{0.9}} \right) \leq 0.95d \quad 3.5$$

$$K = \frac{M}{f_{us} b d^2} \quad 3.6$$

This is the top steel if the section is under negative moment and the bottom steel if the section is under positive moment.

- If $M > M_{\text{single}}$, the area of compression reinforcement, $A's$, is given by [4].

$$A's = \frac{M - M_{\text{single}}}{(f_s - 0.67 f_{cu} / \gamma_c) (d - d')} \quad 3.7$$

where d' is the depth of the compression steel from the concrete compression face, and

$$f_s = 700 \left(1 - \frac{2d'}{d} \right) \leq 0.95 f_y \quad 3.8$$

This is the bottom steel if the section is under negative moment. From equilibrium, the area of tension reinforcement is calculated as

$$A_s = \frac{M_{\text{single}}}{(0.95 f_y) Z} + \frac{M - M_{\text{single}}}{(0.95 f_y) (d - d')} \quad 3.9$$

A_s is to be placed at the bottom of the beam and A_s' at the top for positive bending and vice versa for negative bending.

3.2.5 Shear Reinforcement Design Formulas

The following steps are involved in designing the shear reinforcement for a particular beam for a particular load combination resulting from shear forces in a particular direction [4].

- Calculate the design shear stress and maximum allowable shear stress as

$$v = \frac{V}{A_{cv}} \quad 3.10$$

$$v \leq 0.8R_{LW}\sqrt{f_{cu}} \quad 3.11$$

$$v_{\max} = \min(0.8R_{LW}\sqrt{f_{cu}}, 5.0\text{MPa}) \quad 3.12$$

where, $A_{cv} = bwd$, and

R_{LW} is a shear strength reduction factor that applies to light weight concrete. It is equal to 1.0 for normal weight concrete. The factor is specified in the concrete material properties.

If v exceeds $(0.8R_{LW}\sqrt{f_{cu}})$ or 5.0MPa, the section is overstressed. In this case, the concrete shear area should be increased.

Calculate the design concrete shear stress from (clause 3.4.5.4, Table 3.8 [4])

$$v_c = R_{LW} \frac{0.79K_1K_2}{\gamma_m} \left(\frac{100A_s}{bd} \right)^{\frac{1}{3}} \left(\frac{400}{d} \right)^{\frac{1}{4}} \quad 3.13$$

where, K_1 is the enhancement factor for support compression, and is conservatively taken as 1,

$$K_2 = \left(\frac{f_{cu}}{25} \right)^{\frac{1}{3}} \geq 1 \quad 3.14$$

$\gamma_m = 1.25$, and

A_s is the area of tensile steel.

However, the following limitations also apply

$$0.15 \leq \frac{100A_s}{bd} \leq 3 \quad 3.15$$

$$\frac{400}{d} \geq 1 \quad 3.16$$

- If $V \leq V_c + 0.4$, provide minimum links given by (clause 3.4.5.3 [4])

Else if $V_c + 0.4 < V < V_{\max}$, provide links given by

$$\frac{A_{sv}}{S_v} \geq \frac{(V - V_c)b}{0.95f_{yv}} \quad 3.17$$

Else if $V \geq V_{\max}$ a failure condition is declared.

3.2.6 Compression Resistance of the Precast Beam

The compression resistance the top and shear reinforcement is evaluated as follows using the compression resistance formulas stated below (clause 4.7, Annex C [4])

$$P_c = A_g p_c \quad 3.18$$

where p_c is the compressive strength given by

$$P_E = \frac{\pi^2 E}{\lambda^2} \quad 3.19$$

$$\phi = \frac{P_y + (\eta + 1) P_E}{2} \quad 3.20$$

$$p_c = \frac{P_E P_y}{\phi + (\phi^2 - P_E P_y)^{1/2}} \quad 3.21$$

where,

η =Perry factor, $0.001 a (\lambda - \lambda_0) \geq 0$

a = Robertson constant from (Clause 2, Table 23 [4]).

λ_0 =Limiting slenderness, $0.2 \left(\frac{\pi^2 E}{P_y} \right)^{1/2}$, (clause.2 [4]).

λ = The slenderness ratio in either the major, $\lambda_{22} = l_{e33}/r_{33}$, or in the minor, $\lambda_{33} = l_{e22}/r_{22}$ direction. The larger of the two values is used in the above equations to calculate P_c and

P_y = the yield strength. For welded sections, P_y is reduced by a value of 20MPa for the purpose of calculating p_c [4].

3.3 DESIGN PROCEDURE FOR THE PRECAST BEAM ELEMENT

The design procedure given below can be used to design precast beam elements for the construction of suspended beam-block slab floors. Each of these steps is demonstrated by a practical design example as shown in the next section.

- i- Determine the loads on the slab system both at the initial and final conditions of the precast beam. The loading in the case of initial and final conditions of the precast beam shall be separately analyzed for different loading considerations and an initial trial section shall also be assumed.

a) Loading for the initial condition:

The loading considered in this condition of the precast beam are as follows:

Dead load:

- Weight of precast beam concrete.
- Weight of hollow ribbed slab block.

Live load:

- The live load at the time of handling and placing are considered here.
- Weight of wet concrete at the time of casting is also considered as dynamic load on the precast beam.

b) Loading for the final condition:

The loading considered in this condition of the precast beam are as follows:

Dead load:

- Weight of precast beam concrete
- Weight of hollow ribbed slab block
- Weight of cast in-situ concrete
- Weight of partition
- Weight of cement screed and weight of cement plasters

Live Load:

- This depends on the purpose of the structure

ii- On the basis of the above loading for the different conditions of precast beam determine the moment and shear at the critical sections both at the initial and final conditions of the precast beam.

iii- Using the critical moment and shear forces the predefined section and the assumed reinforcements shall be checked for buckling resistance and for the requirement of temporary support for the case of the initial condition state of the precast beam.

Temporary supports are provided when the precast beam in its initial condition cannot support all the loads at the initial condition state. When the length of precast beam is getting longer (more than 3.5m), the tendency for provision of temporary support increases.

a) Check for buckling resistance of top reinforcement:

- Calculate the critical moment in the precast beam at the initial condition state and determine the compression force coming to the top bar using the calculated moment.
- Calculate the compression resistance of the top bar by taking in to consideration the unsupported length of the bar. If the compression force coming to the top bar is greater than the compression resistance one of the following actions can be taken depending on the designer's choice:
 - ✓ Increase the diameter of the top bar.
 - ✓ Reduce the center to center spacing of the diagonal stirrup to reduce the unsupported length of the top bar.
 - ✓ Provide intermediate support to the precast beam at the time of construction.

b) Check for buckling resistance of diagonal shear reinforcement:

- Calculate the critical shear in the pre-cast beam at the initial condition state and using it, determine the compression force coming to the diagonal shear reinforcement.
- Calculate the compression resistance of the diagonal shear reinforcement by taking in to consideration the unsupported length of the bar. If the compression force coming to the shear reinforcement is greater than the compression resistance, one of the following actions can be taken depending on the designer's choice:
 - ✓ Increase the diameter of the bar
 - ✓ Provide intermediate support to the precast beam at the time of construction.

vi- The moment and shear forces are then calculated based on the loading of the final condition to calculate the bottom reinforcement and also to check the top reinforcement determined in the initial condition, if it is sufficient for the compression reinforcement.

v- Finally the slab section in the final condition shall be checked for shear resistance and if it has no sufficient resistance the section shall be increased.

Note that all the above calculations and checking shall be as per the British standard, structural use of concrete part-1 code of practice for design and construction (BS 8110.1997)

3.4 DESIGN EXAMPLE ON PRECAST BEAM-HCB FLOOR SLAB SYSTEM

To achieve the objective of this research, a typical four story building, the floor plan of which is as shown in the Fig 2.1 is chosen. The analysis and design of the slab system is carried out using the precast beam-hollow block slab as follow.

Design load combinations

From Eq. 3.1

$$L_c = 1.4 \text{ DL} + 1.6 \text{ LL}$$

Design strength for concrete and steel

Partial factor of safety γ_m taking from Eq. 3.2

Materials

Concrete C-25

$$f_{cu} = 25 \text{ N/mm}^2$$

$$f_{cd} = \frac{0.85 \times f_{ck}}{\gamma_m}, \text{ in compression}$$

$$f_{cd} = \frac{f_{ctk}}{\gamma_c}, \text{ in tension}$$

where,

f_{ck}, f_{ctk} are the characteristic cylinder compressive and tensile strength of concrete, respectively

for C-25, $f_{ck} = 20 \text{ MPa}$

$f_{ctk} = 1.5 \text{ MPa}$

$$f_{cd} = \frac{0.85 \times 20}{1.50} = 11.33 \text{ MPa}$$

Steel S-400

The design strength of steel in tension and compression is given by

$$f_{yd} = \frac{f_{yk}}{\gamma_m}$$

$$f_{yd} = \frac{400}{1.05} = 347.83 \text{ MPa}$$

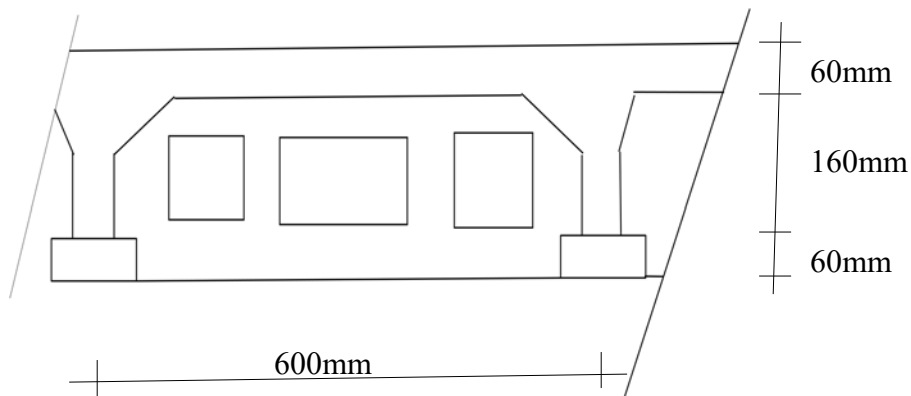

Figure 3.2 Cross-section of Precast beam and slab HCB

a) Geometric property

Description	Dimension	Unit
Width, b	0.120	m
Depth for initial condition	0.060	m
Depth of slab, D	0.280	m
d'	0.028	m
Span length, L	5.000	m
Effective depth, d	0.250	m
Center to center distance b/n ribs	0.600	m
Area of slab HCB, A_{Sblock}	0.0511	m^2
$A_{S.block}$	0.105	m^2

b) Material property

Quality of materials	Notations	value	unit
Concrete , C-25	f_{ck}	20.00	N/mm ²
	f_{cd}	11.33	N/mm ²
	f_{ctd}	1.03	N/mm ²
Steel, S-400	f_{yk}	400.00	N/mm ²
	f_{yd}	380.95	N/mm ²
	E	200,000.00	MPa

c) Loading

γ_{Concrete}	25.00	kN/m ³
$\gamma_{\text{S-block}}$	19.35	kN/m ³
γ_{Mortar}	23.00	kN/m ³
Live load	3.00	kN/m ² (at Service)
Live load(Erection)	0.50	kN/m ² (during Erection)
Dead load (partition)	1.00	kN/m ²

The design is done by considering the precast beam in to two different conditions.

i. Initial condition precast beam and

ii. Final condition of precast beam

i. Initial condition

Two loading cases are considered in the design at the initial condition state of the precast beam.

Case 1: when only live load, no fresh concrete

Dead load (DL)

$$\text{Precast beam} \dots\dots\dots 0.12 \times 0.06 \times 25 = 0.180 \text{ kN/m}$$

$$\text{Hollow block} \dots\dots\dots 0.0511 \times 19.35 = 0.989 \text{ kN/m}$$

$$\text{Total dead load DL} \dots\dots\dots = 1.169 \text{ kN/m (unfactored)}$$

3.4 Design example....

(Cont'd)

Live load (LL)

Center to center distance between ribs = 0.60m

Live load during erection (assumption) = 0.50kN/m²

L.Load during erection.....= 0.60m×0.50 kN/m² = 0.30kN/m

Design load (DL + LL)..... = 1.469kN/m (unfactored)

Case 2: When minimum Live load and fresh concrete poured

Dead load (DL)

Precast beam.....0.12×0.06×25 = 0.180kN/m

Hollow core.....0.0511×19.35 = 0.989kN/m

Total dead load DL.....= 1.169kN/m (unfactored)

Live load (LL)

Load during erection (1/2 of LL_{Erection}) = 1/2×0.60m× 0.50kN/m² = 0.15kN/m

Fresh concrete (LL)

Considering the fresh concrete as live load b/c of its dynamic action during pouring)

(0.28m×0.6m-(0.105m²+0.12m×0.06m))25kN/m³=1.395kN/m

Total live load LL.....=1.545kN/m

Design Load (DL + LL)..... =2.714kN/m (unfactored)

Thus case 2 governs and the analysis will be done for the governing loading case.

Analysis for governing initial condition

i) Check for buckling resistance of shear reinforcement:

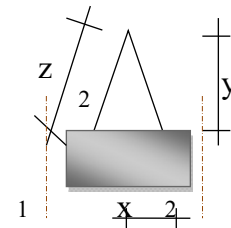
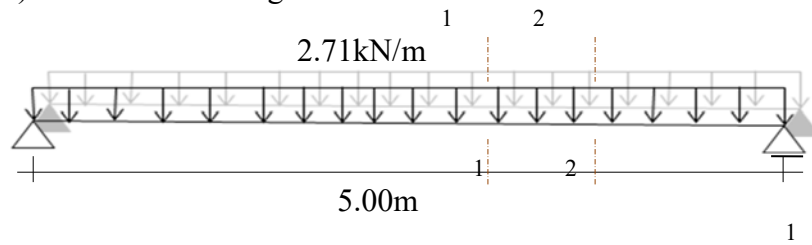

$$V_{\max} = P_d \times L/2 = 6.775 \text{ kN}$$

Center to center spacing of shear reinforcement = 0.15m

x=0.075m

y=0.200m

3.4 Design example....

(Cont'd)

The value of z is approximately equal to $\sqrt{(x^2+y^2)}=0.214\text{m}$

There are two diagonals on each face. Therefore, the approximate value of Compression force in the diagonals will be

$$C_a = \left(\frac{z}{y} \right) \frac{V_{\max}}{2} = 3.62\text{kN}$$

Design buckling resistance of shear reinforcement is:

Compression resistance from Eq.3.18

$$P_c = A_g \times p_c$$

where A_g is area of shear reinforcement

$$\frac{\pi \times 6^2}{4} \times p_c$$

Diameter of shear reinforcement is 6mm

$$A_g = 28.26\text{mm}^2$$

Compressive strength is calculated from Eq.3.19, 3.20 and 3.21

a (Robertson constant) = 5.5

L_e (unsupported length of stirrup) = 214.0mm

$i = d/4 = 1.5\text{mm}$

$\lambda = L_e/i = 142.4 \leq 180$

P_y (Yield strength) = 400MPa

$$P_E = \frac{\pi^2 E}{\lambda^2}$$

$$P_E = 97.34\text{MPa}$$

$$\lambda_0 = 0.2 \left(\frac{\pi^2 E}{P_y} \right)^{1/2}$$

$$\lambda_0 = 14.05$$

and

$$\eta = 0.001 a (\lambda - \lambda_0) \geq 0$$

$$\eta = 0.71$$

$$\phi = \frac{P_y + (\eta + 1) P_E}{2}$$

$$\phi = 283.23\text{Mpa}$$

3.4 Design example....

(Cont'd)

The compressive strength using Eq.3.21

$$p_c = \frac{P_E P_y}{\phi + (\phi^2 - P_E P_y)^{1/2}}$$

$$p_c = 80.13 \text{ Mpa}$$

The compression resistance

$$P_c = A_g \times p_c$$

$$= 2.27 \text{ kN}$$

which is less than the compression force in diagonals (shear reinforcement). Therefore provide an intermediate support and repeat the analysis.

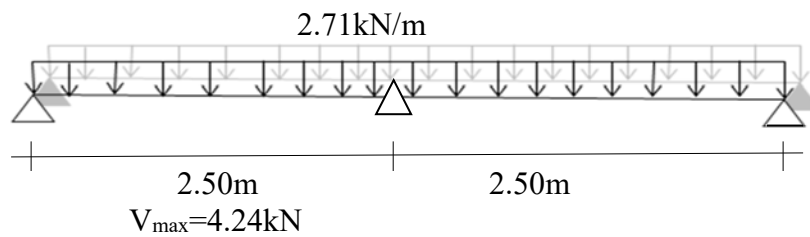

Using the additional support at the mid span, the approximate value of compression force in diagonals will be

$$C_a = \left(\frac{z}{y} \right) \frac{V_{\max}}{4}$$

$$C_a = 1.13 \text{ kN}$$

Compression resistance of the shear reinforcement is 2.27 kN

Therefore $2.27 \text{ kN} > 1.13 \text{ kN}$ (the compression force in diagonals)

Hence, the precast beam is safe by providing intermediate support for shear, and the top bar buckling resistance shall be checked by considering the intermediate support.

ii) Check the buckling resistance of top reinforcement

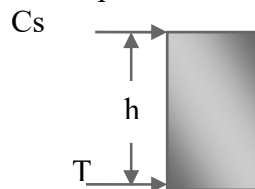

3.4 Design example....

(Cont'd)

Maximum design positive moment of precast beam with in the span:

$$M = 0.07 \times (P_d) \times (L/2)^2$$

$$= 1.186 \text{ kNm}$$

where M is positive span moment.

The compressive force

$$C_s = M/h = 4.96 \text{ kN}$$

where h is 0.24m

Design buckling resistance of compression steel is

Compression resistance

$$P_c = A_g \times p_c,$$

where A_g is area of top reinforcement given by:

$$A_g = \frac{\pi \times 12^2}{4} \times p_c$$

Diameter of top reinforcement (d) = 12mm

$$A_g = 113.10 \text{ mm}^2$$

Compressive strength is calculated from Eqs.3.19, 3.20 and 3.21.

$$P_E = \frac{\pi^2 E}{\lambda^2}$$

$$\phi = \frac{P_y + (\eta + 1)P_E}{2}$$

$$p_c = \frac{P_E P_y}{\phi + (\phi^2 - P_E P_y)^{1/2}}$$

$E = 200 \text{ GPa}$

a (Robertson constant) = 5.5

$L_e = 150.0 \text{ mm}$

$I = d/4 = 3 \text{ mm}$

$\lambda = L_e/i = 50 \leq 180$

P_y (Yield strength) = 400MPa

λ_o (Limiting slenderness) = 14.05

η = Perry factor, $0.001 a (\lambda - \lambda_o) \geq 0$

3.4 Design example....

(Cont'd)

$$\eta \text{ (perry factor)} = 0.198$$

$$P_E \text{ (Euler strength)} = 789.57 \text{ MPa}$$

$$\phi = 672.84 \text{ MPa}$$

The Compressive Strength is calculated using Eq.3.21

$$P_c = 302.86 \text{ MPa}$$

The compression resistance is calculated using Eq.3.18

$$P_c = A_g \times p_c$$

$$= 34.25 \text{ kN} > 4.96 \text{ kN compression force in top reinforcement.....ok!}$$

Therefore "Use 1 ϕ 12 for top bar with c/c spacing of ϕ 6 stirrups = 150mm"
and proceed to the final condition.

ii- Final condition

Factored design load (P_d) = 1.4DL + 1.6LL

Dead load (DL):

$$\text{Precast beam.....} = 0.135 \text{ kN/m}$$

$$\text{Hollow concrete block} = 0.98 \text{ kN/m}$$

$$\text{Cast in-situ concrete.....} = 1.39 \text{ kN/m}$$

$$\text{Partition.....} = 0.60 \text{ kN/m}$$

$$\text{Cement screed.....} = 0.69 \text{ kN/m}$$

$$\text{Cement plasters.....} = 0.27 \text{ kN/m}$$

$$\text{Total dead load.....} = 4.06 \text{ kN/m}$$

$$\text{Factored dead load (DL)} = 1.4 \times 4.06 \text{ kN/m} = 5.68 \text{ kN/m}$$

$$\text{Live load} = 3.0 \text{ kN/m}^2 \times 0.6 \text{ m} = 1.8 \text{ kN/m}$$

$$\text{Factored live load} = 1.6 \times 1.8 \text{ kN/m} = 2.88 \text{ kN/m}$$

$$\text{Total design load } P_d = 5.68 + 2.88 = 8.56 \text{ kN/m}$$

Therefore the maximum design moment will be:

$$M_{\max} = \frac{P_d l^2}{8} = 26.75 \text{ kN-m}$$

3.4 Design example....

(Cont'd)

Span length = 5.00m

Effective depth $d = D - d' = 0.260\text{m}$

Ultimate resistance of the section as a singly reinforced beam from Eq.3.3

$$M_{\text{single}} = K' f_{\text{cub}} d^2, \text{ where } K' = 0.156. \\ = 13.80 \text{ kN-m}$$

$M > M_{\text{single}}$, compression reinforcement is required

$$d' = 25 \text{ mm}$$

$$d = 260 \text{ mm}$$

$$f_y = 380.95 \text{ N/mm}^2$$

From Eq.3.8

$$f'_s = 700 \left(1 - \frac{2d'}{d} \right) \leq 0.95 f_y = 700 \left(1 - \frac{2 \times 25}{260} \right) = 565.38 > 0.95 \times 380.95 = 361.90$$

So use $f'_s = 361.90 \text{ N/mm}^2$

Using Eq.3.7, $A'_s = 151.64 \text{ mm}^2$ which is greater than the top reinforcement considered in the buckling resistance requirement.

Therefore **"Use 1 ϕ 14 for top bar with c/c spacing of ϕ 6 stirrups = 150mm"**

The bottom (the tension) reinforcement is obtained from Eq.3.9:

$$A_s = \frac{M_{\text{single}}}{(0.95 f_y) z} + \frac{M - M_{\text{single}}}{(0.95 f_y) (d - d')}$$

$$z = 0.777d = 201.99 \text{ mm}$$

$$A_s = 341.05 \text{ mm}^2. \text{ "Therefore use 2 } \phi \text{ 16 for bottom reinforcement"}$$

Shear reinforcement calculation

Design shear stress and allowable shear stress

Design shear stress

$$v = V / A_{\text{cv}} \text{ from Eq.3.10}$$

$$V = P_a l / 2 = 8.60 \times 5 / 2 = 21.50 \text{ kN}$$

3.4 Design example....

(Cont'd)

$$A_{cv} = b \times d = 0.12 \times 0.255 = 0.031 \text{m}^2$$

$$v = 693.55 \text{kN/m}^2 = 0.694 \text{Mpa}$$

Allowable shear stress

$$v_{\max} = \min(0.8R_{LW} \sqrt{f_{cu}}, 5.0 \text{MPa})$$

where R_{LW} is shear strength reduction factor, it is equal to 1 for normal weight concrete.

The factor is specified in the British standard concrete material properties [4]

$v_{\max} = 2.69 \text{MPa}$, which is greater than the shear stress = 0.694MPaok!

If v exceeds $(0.8R_{LW} \sqrt{f_{cu}})$ or 5MPa the analysis shows an overstress. In this case, the concrete shear area should be increased.

The design concrete shear stress obtained from Eq.3.13.

$$\gamma_m = 1.25$$

$$A_s (\text{area of tensile steel}) = 401.92 \text{mm}^2$$

$$K_1 (\text{enhancement factor}) = 1$$

$$K_2 = (f_{cu}/25)^{1/2} = 0.768 \geq 1 \text{ so take } 1$$

$$1.50 \leq 100A_s/bd = 1.514 \leq 3.00 \text{.....ok}$$

$$400/d = 1.569 \geq 1.00 \text{.....ok}$$

$$(100A_s/bd)^{1/3} = 1.095$$

$$(400/d)^{1/4} = 1.119$$

The design concrete shear stress v_c is given by

$$v_c = R_{LW} \frac{0.79K_1K_2}{\gamma_m} \left(\frac{100A_s}{bd} \right)^{1/3} \left(\frac{400}{d} \right)^{1/4}$$

$$v_c = 0.774 \text{MPa}$$

$v \leq v_c + 0.4$ provide shear reinforcement defined by

$$\frac{A_{sv}}{S_v} \geq \frac{0.4b_s}{0.95f_{yv}}$$

Therefore Use ϕ 6 c/c spacing 150mm

3.4 Design example.....

(Cont'd)

Following the above procedures design of precast beam is made for different classes of concrete and section properties as shown in the table below

Concrete Class	Geometrical Dimension			Reinforcement Required	
	b (mm)	Effective Depth of Slab d (mm)	Depth of PB at Initial Condition h (mm)	Top Reinforcement As'	Bottom Reinforcement As
C-25	120	260	60	1 Φ 14	2 Φ 16
	100	260	60	1 Φ 16	2 Φ 16
C - 30	120	260	60	1 Φ 12	2 Φ 16
	100	240	60	1 Φ 16	2 Φ 16
C - 40	120	240	60	1 Φ 12	2 Φ 16
	100	220	50	1 Φ 14	2 Φ 16

Table 3.1 Final output of precast beam design for different classes of concrete

CHAPTER 4

DESIGN OF PRESTRESSED HOLLOW CORE CONCRETE SLAB

4.1 GENERAL

The design of hollow core slabs is governed by the BS.8110:1997 part-1 code of practice for design and construction requirements for structural concrete. As with prestressed concrete members in general, hollow core slabs are checked for prestress transfer stresses, handling stresses, service load stresses deflections and design (ultimate) strength in shear and bending.

To this effect different mathematical and empirical formulas including codes provisions for precast members are assessed on the basis of which the design of the hollow core floor units are considered. These are then demonstrated using examples. Finally, the prestressed hollow core slab is compared with the precast beam-block floor slabs. In the foregoing presentation, the sign convention will be negative for compressive stress and positive for tensile stresses.

4.2 STRESS LIMITS

Depending on the serviceability requirements for a particular structure, a designer may set limits on the tensile and compressive stresses in concrete both at transfer and under the full service loads.

For the design of a fully prestressed member, stress limits both at transfer and full loads are selected to ensure that cracking does not occur at any time. Different codes of practice set maximum limits on the magnitude of the concrete stress, both in tension and compression. For partially prestressed members, where cracking is permitted under service loads and the tensile stress limits are exceeded, a detailed non-linear analysis is required to determine the behavior of the structure in the post-cracking range [9].

There are relatively few situations that specifically require no cracking as a design requirement. These include:

- For long span members, where self-weight is a major part of the design load, relatively large prestressing forces are required to produce an economic design.

- Fully prestress construction is also desirable if a crack-free or water-tight structure is required or if the structure needs to possess high fatigue strength.

In building structures, however, where the spans are generally small to medium, full prestressing may lead to excessive camber and partial prestressing is often a better solution.

British standard code of practice for design and construction (BS.8011:1997 part-1) presents provisions for the flexural design of prestressed concrete members.

The applicable concrete stress limits are paraphrased as follows [12, 4].

- Permissible stresses immediately after transfer
 - a) Extreme fiber stress in compression: $0.5f_{ci}$
 - b) Extreme fiber stress in tension: 1N/mm^2 , for no flexural cracking allowed
 $0.45\sqrt{f_{ci}}$, for no visible cracks
- Permissible stresses at service loads
 - a) Extreme fiber stress in compression $0.33f_{cu}$
 - b) Extreme fiber stress in tension 0 for no flexural cracking allowed
 $0.45\sqrt{f_{cu}}$ for possible crack

where, f_{ci} is the characteristic cube compressive strength of concrete at transfer

f_{cu} is the cube strength of concrete

BS.8110:1997 part-1 also set mandatory limits on the tensile stress in the prestressing steel at various stages of loading. Accordingly, at the time of initial tensioning, initial prestress should not normally exceed 70% of the characteristic tensile strength and in no case should it exceed 75%. Final stress after allowing for all losses of prestress should not be greater than 60% of the characteristic tensile strength of tendons [9].

4.3 STRESSES AT TRANSFER

When the prestressing strands are cut to apply the prestressing force to the concrete, only the slab self weight is present to counteract the effects of eccentric prestress. A check of stresses is required at this point to determine the concrete strength required to preclude cracking on the tension side or crushing on the compression side. The concrete strength at the time of transfer may be only 50% to 60% of the 28 day design strength [7].

4.4 PRESTRESS LOSSES

The accuracy of any calculation method is dependent on the preciseness of concrete and prestressing steel material properties as well as external factors such as humidity used in the calculation procedure. The accuracy of loss calculations has little effect on the ultimate strength of a member.

Prestress loss calculations are required for prediction of camber and for service load stress calculations. Since the success of a project is judged on service load performance rather than ultimate strength, it behooves any slab producer to use a loss calculation procedure which best predicts the behavior of the product as produced. For low relaxation strand and for special cases (e.g., long spans or special loadings) using stress relieved strand, the BS.8011:1997 part1 code references several sources for prestress loss calculations and considers the following parameters.

4.4.1 Immediate Loss

Immediately after transfer, the change in strain in the prestressing steel $\Delta\varepsilon_p$ caused by elastic shortening of the concrete is equal to the strain in the concrete at the steel level, ε_{cp} . The compatibility equation can be expressed as follows [9].

$$\varepsilon_{cp} = \frac{\sigma_{cp}}{E_c} = \Delta\varepsilon_p = \frac{\Delta\sigma_p}{E_p}$$

The loss of stress in the steel, $\Delta\sigma_p$ due to elastic shortening is

$$\Delta\sigma_p = \frac{E_p}{E_c} \sigma_{cp} \tag{4.1}$$

where, σ_{cp} is the concrete stress at the steel level immediately after transfer

$$\sigma_{cp} = \frac{p_i}{A} - \frac{p_i e^2}{I} + \frac{M_o e}{I} \tag{4.2}$$

Where, M_o is the external moment resulting from the load acting at transfer.

4.4.2 Time Dependent Losses

The gradual loss of prestress that takes place with time is called time dependent loss.

i) Shrinkage Losses

When ordinary Portland cement hydrates and subsequently dries, it undergoes shrinkage in volume. The amount of this shrinkage depends to some extent on the richness of the mix and on the initial water content [6].

The loss of stress in a tendon due to shrinkage of concrete may be approximated by [9].

$$\Delta\sigma_p = \varepsilon_{sh} E_p \quad 4.3$$

where $\varepsilon_{sh}(t)$ is the shrinking strain at the time under consideration.

E_p is the modulus of elasticity of the prestressing tendons

For the purpose of prestressed concrete design it is usually assumed that this shrinkage has a maximum value of the order of 300×10^{-6} and this is the value to be recommended by BS.8011:1997 for design. This is the total reduction in volume that may be expected from the time of the initial set. On the other hand, a concrete which is damp-cured and which remains quite damp until stressing, will have undergone little change in volume. However, for normal curing something like 100×10^{-6} will have occurred before stressing [6]. This will result to a shrinkage loss of between 57.5 N/mm^2 and 60 N/mm^2 , respectively, which is about 5% in both cases [9, 12].

ii) Creep Losses

The creep of concrete is dependent upon the following factors magnitude of stress on the concrete section, the age of the concrete at the time of application of the stress, the quantity of mixing water, the strength of the concrete and the properties of the aggregates and cement [6].

Assuming the concrete stress at the tendon level remains constant with time and equal to its initial (usually high) value σ_c , the creep strain at any time t after transfer may be calculated from [9]:

$$\varepsilon_c(t) = \frac{\sigma_c}{E_c} \phi \quad 4.4$$

where,

$\varepsilon_c(t)$ is the creep strain, ϕ is the creep coefficient, σ_c is the concrete stress at the centroid of prestressing steel at mid-span immediately after the application of the full sustained load, M_{sus} .

$$\sigma_c = -\frac{p_i}{A} - \frac{p_i e^2}{I} + \frac{M_{sus} e}{I} \quad 4.5$$

$$\Delta\sigma_p = \varepsilon_c(t)E_p \quad 4.6$$

The magnitude of the creep coefficient ϕ varies depending upon the humidity, concrete quality, duration of applied loading and the age of the concrete when loaded. The general values recommended for the creep coefficient vary from 1.5 for watery situations to 4.0 for dry condition with a relative humidity of 35% [9].

iii) Steel relaxation loss

This is a loss resulting from a stress relieving heat treatment process. A 1000-hour relaxation test value is provided by manufactures. Codes of practice add margins to this value. BS.8110:1997 give a factor of safety of 1.2. The relaxation loss ranges from 3 to 6 percent [4, 12].

4.5 FLEXURAL CAPACITY

4.5.1 Serviceability Limit State of Flexure

The moment capacity of a prestressed member is a function of the ultimate stress developed in the prestressing strands. As with non-prestressed concrete, upper and lower limits are placed on the amount of reinforcing to ensure that the stress in the strands is compatible with concrete stresses for ductile behavior of the structure. For a partially prestressed member, where flexural cracking allowed but not with visible crack, the serviceability moment of resistance is given by the lesser of.

$$M_{sr} = (f_{bc} + 0.45\sqrt{f_{cu}})Z_b$$

or

$$M_{st} = (f_{tc} + 0.33f_{cu})Z_l$$

4.7

$$\text{where } f_{bc} = p_e \left(\frac{1}{A} + \frac{e}{Z_b} \right) \text{ and } f_{tc} = p_e \left(\frac{1}{A} - \frac{e}{Z_t} \right)$$

This ensures that when the concrete develops flexural cracks, the prestressing steel will not have reached its full design stress. Violation of this criterion might result in strand fractures at the point of flexural cracking with a resulting brittle failure.

The serviceability moment of resistance, M_{sr} is calculated by limiting the flexural compressive and tensile stresses in the concrete both at transfer condition and in service.

Figure 4.1 shows the stress conditions at each of these stages

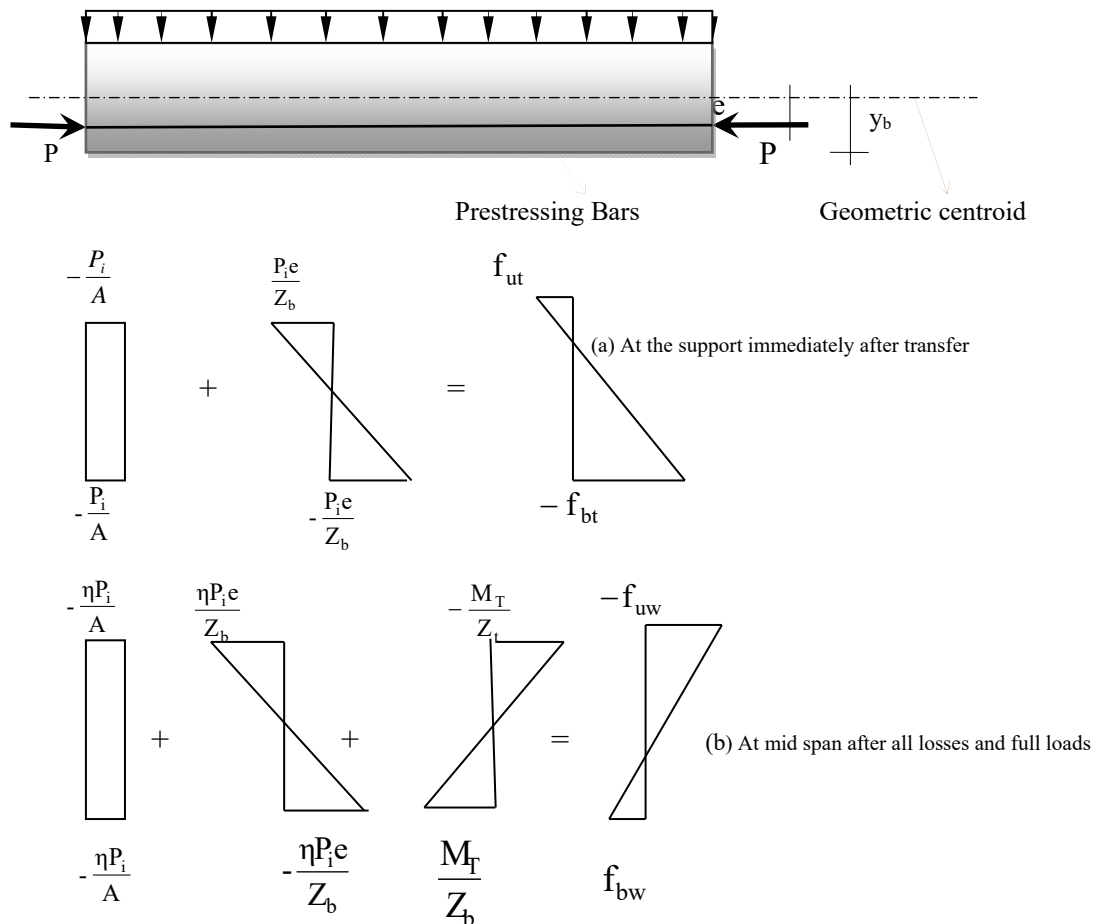

Figure 4.1 Stress conditions

At transfer, the maximum concrete tensile and compressive stresses occur at the support. The tensile top fiber stresses must be less than the tensile stress limit f_{tt} .

The compressive bottom fiber stress must be numerically less than the compressive stress limit f_{ct} .

$$f_{ut} = -\frac{p_i}{A} + \frac{p_i e}{Z_t} \leq f_{tt} \quad 4.8$$

$$f_{bt} = -\frac{p_i}{A} - \frac{p_i e}{Z_b} \leq f_{ct} \quad 4.9$$

Assuming $\alpha_u = \frac{A}{Z_t}$ and $\alpha_b = \frac{A}{Z_b}$ and expressing $\frac{1}{p_i}$ as a liner function of e , we get:

$$\frac{1}{p_i} \geq \frac{\alpha_u e - 1}{A f_{tt}} \quad 4.10$$

$$\frac{1}{p_i} \geq \frac{\alpha_b e + 1}{-A f_{ct}} \quad 4.11$$

After all the time-dependent loss has taken place, the maximum tensile stress occurs in the bottom concrete fiber at mid-span and must be less than the tensile stress limit, f_{tw} .

$$f_{bw} = -\frac{\eta p_i}{A} - \frac{\eta p_i e}{Z_b} + \frac{M_T}{Z_b} \leq f_{tw} \quad 4.12$$

Rearranging gives:

$$\frac{1}{p_i} \leq \frac{\eta(\alpha_b e + 1)}{-A f_{tw} + \alpha_b M_T} \quad 4.13$$

The prestress loss factor η can be assumed to be in the range 0.75 to 0.85 in pretensioned concrete [9].

Equations 4.10, 4.11 and 4.13 may be plotted on a graph of $1/p_i$ versus e , and a design diagram is constructed that ensures satisfaction of the selected stress limits both at the support at transfer and at the critical section of maximum moment under the full service loads. This is demonstrated by the example in the next sections.

For a fully prestressed member, the compressive stress in the top fiber must also satisfy the appropriate stress limit. Therefore,

$$f_{uw} = -\frac{\eta p_i}{A} + \frac{\eta p_i e}{Z_t} + \frac{M_T}{Z_t} \geq f_{cw} \quad 4.14$$

Rearranging gives:

$$\frac{1}{p_i} \leq \frac{\eta(\alpha_u e - 1)}{-Af_{cw} + \alpha_u M_T} \quad 4.15$$

Equation 4.15 may also be plotted on the design diagram, but the compressive stress limit f_{cw} at the critical section is rarely of concern in a pre-tensioned member of constant cross-section.

To find the maximum sized section required to satisfy the selected stress limits both at the support and at the mid-span at all stages of loading, Eq.4.9 may be substituted into Eq.4.12 to give:

$$\eta f_{ct} + \frac{M_T}{Z_b} \leq f_{tw}$$

This gives;

$$Z_b \geq \frac{M_T}{f_{tw} - \eta f_{ct}} \quad 4.16$$

Equation 4.16 can be used to select the initial trial, and then the required prestressing force and the maximum permissible eccentricity can be determined using Eqs.4.10, 4.11 and 4.13.

4.5.2 Ultimate Limit State of Flexure

4.5.2.1 Assumptions

To determine the ultimate bending strength M_{ur} of a cross-section, the following assumptions are usually made.

- i- The variation of strain on the cross-section is linear, i.e. plane section before bending remain plane after bending
- ii- concrete carries no tensile stress, i.e. the tensile strength of the concrete is ignored

- iii- The stress in the compressive concrete and in the steel reinforcement (both pre-stressed and non-pre-stressed) are obtained from actual or idealized stress-strain relationship for the respective material.

4.5.2.2 Idealized rectangular compressive stress block for concrete

In order to simplify numerical calculations for ultimate flexural strength, code of practice usually specify idealized rectangular stress blocks for the compressive concrete above the neutral axis as shown in the figure below

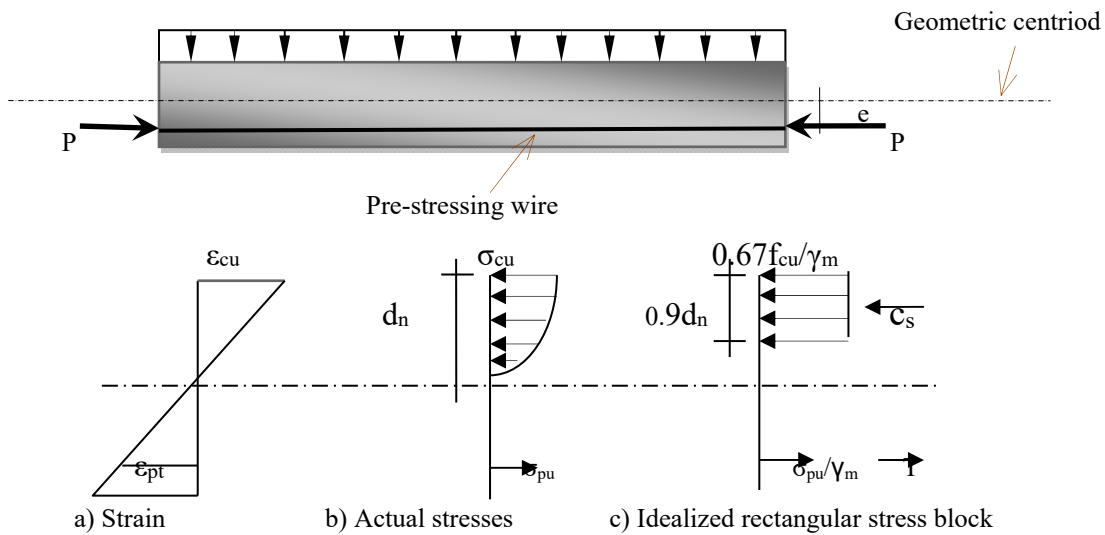

Figure 4.2 Stress blocks

According to BS 8110:1997 part-1, the extreme fiber compressive strain at the ultimate moment, $\epsilon_{cu} = 0.0035$. The depth of the rectangular stress block is $0.9d_n$ and the uniform

stress intensity is $0.67 \frac{f_{cu}}{\gamma_m}$, [1, and 6].

4.5.2.3 Prestresses steel strain components

For reinforced concrete cross-section, the strain in the non-prestressed steel and in the concrete at the steel level is the same at any stage of loading. In a pre-stressed concrete section, this is not so for the prestressing tendons. The strain in the bonded prestressing

steel at any stage of loading is equal to the strain caused by the initial prestress plus the change in strain in the concrete at the steel level.

To calculate the ultimate flexural strength of a section, an accurate estimate of the final strain in the prestressed and non- prestressed steel is required. For a bonded tendon, the tensile strain in the prestressing steel at ultimate ϵ_{pu} is usually considered to be the sum of several sub-components.

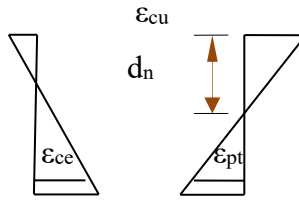

(a) Strain due to the effective prestress (b) Strain at ultimate

Figure 4.3 Strains due to the effective prestress and at ultimate

Figure 4.3 (a) shows the elastic concrete strain caused by the effective prestress when the externally applied moment is zero. The strain in the concrete at the tendon level is compressive, with magnitude equal to:

$$\epsilon_{ce} = \frac{1}{E} \left(\frac{p_e}{A} + \frac{p_e e^2}{I} \right) \quad 4.18$$

where A is the area of the section and I is the second moment of area of the section about its centroidal axis. The stress and strain in the prestressing steel are

$$\sigma_{pe} = \frac{p_e}{A_{ps}} \quad \text{and} \quad \epsilon_{pe} = \frac{\sigma_{pe}}{E_p} \quad 4.19$$

Provided that the steel stress is within the elastic range,

Figure 4.3 (b) corresponds to the ultimate load condition. The concrete strain at steel level ϵ_{pt} can be expressed in terms of the extreme compressive fiber strain ϵ_{cu} and the depth to the natural axis at failure d_n as:

$$\epsilon_{pt} = \epsilon_{cu} \left(\frac{d_p - d_n}{d_n} \right) \quad 4.20$$

The strain in the pre-stressing tendon at the ultimate load condition may be obtained from:

$$\epsilon_{pu} = \epsilon_{pe} + \epsilon_{ce} + \epsilon_{pt} \quad 4.21$$

In general, the magnitude of ϵ_{ce} is very much less than either ϵ_{pe} or ϵ_{pt} , and usually be ignored with and without introducing serious errors [9].

4.5.2.4 Determination of the ultimate moment of resistance, M_{ur}

In order to calculate the ultimate bending strength, the depth to the natural axis d_n and the final stress in the prestressing steel σ_{pu} must first be determined. An iterative trial and error procedure is usually used to determine the value of d_n and hence M_{ur} as given below [9].

- i-Select an appropriate trial value of d_n and determine ϵ_{pu} from Eq.4.21 by equating the tensile force in the steel to the compressive force in the concrete, determine the stress in the tendon.
- ii-Plot the point ϵ_{pu} and σ_{pu} on the graph containing the stress-strain curve for the prestressing steel. If the point falls on the curve, then the value of d_n selected is correct.
- iii-If point $(\epsilon_{pu}, \sigma_{pu})$ obtained is not sufficiently close to the stress-strain curve for the steel, repeat with a new estimate of d_n .
- iv-Interpolate between the plots from steps 2 and 3 to obtain a close estimate for ϵ_{pu} and σ_{pu} and also the corresponding value for d_n .
- v-With the correct values of σ_{pu} and d_n determined in step 4, calculate the ultimate moment M_{ur} .

When the rectangular stress block is less than the thickness of the flange, i.e. when the portion of the section subjected to the uniform compressive stress is rectangular; the section is considered to be rectangular and the equations derived for this kind of section are applicable in this case, the ultimate strength M_{ur} is unaffected by the shape of the section below the compressive stress block.

When the compressive stress block acts on the non-rectangular portion of the cross-section the idealized stress block may still be used. But some modifications to the compression force and the geometry are made as follows.

It is convenient to separate the resultant compressive force in the concrete into a force in the flange C_{cf} and a force in the web C_{cw} as shown in the Fig.4.4 below.

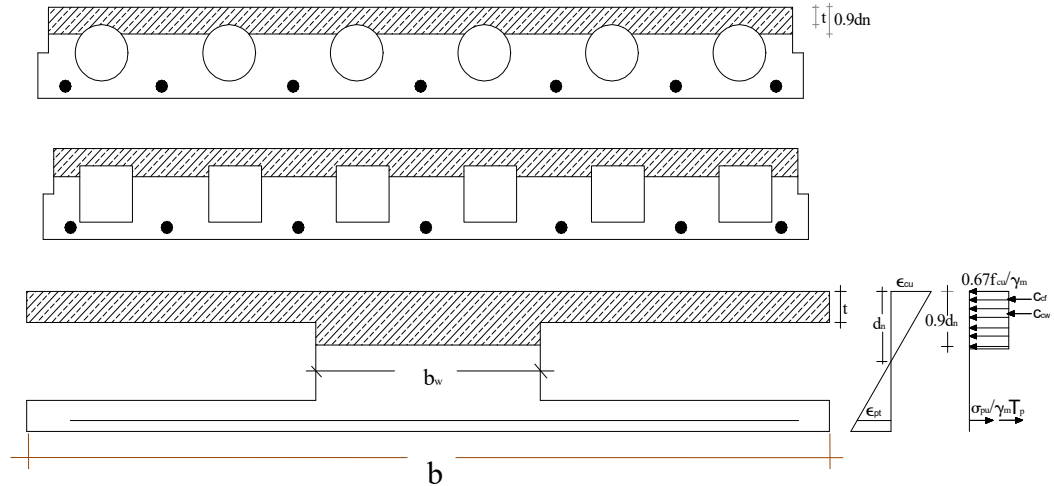

Figure 4.4 Hollow core concrete floor and equivalent section

$$C_{cf} = \frac{0.67f_{cu}tb}{\gamma_m} \quad \text{and} \quad C_{cw} = \frac{0.67f_{cu}(0.9d_n - t)b_w}{\gamma_m} \quad 4.22$$

Final width of the webs b_w can be taken to be as the sum of each of the individual webs approximated by the circumscribing rectangle as shown in Fig.4.4 above.

By equating the tensile and compressive forces on the section, the depth to the neutral axis d_n can be determined by trial and error and the ultimate moment M_{ur} can be obtained by taking moments about of the internal forces about any convenient point on the cross-section.

4.5.2.5 Section containing non-prestressed reinforcements

Non-prestressed reinforcement may be used in both the compressive and tensile zones of a cross-section. In the tensile zone, it is used to provide additional flexural strength and also to improve crack control. In the compressive zone, it is used to increase the ultimate strength and also causes increased curvature at failure and therefore improves ductility. Non-prestressed reinforcement also reduces long-term deflections caused by creep and shrinkage and therefore improves serviceability.

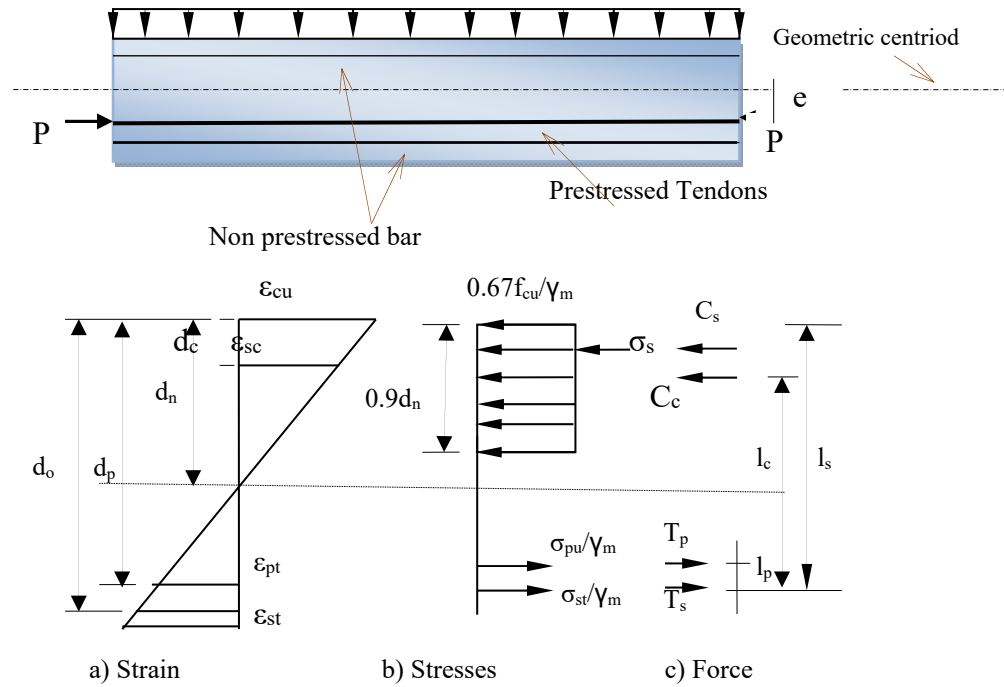

Figure 4.5 Section containing both tensile and compressive reinforcements

From the geometry, the magnitude of strain in the compressive steel is:

$$\epsilon_{sc} = \frac{\epsilon_{cu} (d_n - d_c)}{d_n} \quad 4.23$$

$$\sigma_{sc} = \begin{cases} \epsilon_{sc} E_s, & \text{for } \epsilon_{sc} \leq \epsilon_y \\ f_y, & \text{for } \epsilon_{sc} > \epsilon_y \end{cases}$$

The magnitude of strain at ultimate in the non-prestressed tensile steel is:

$$\epsilon_{st} = \frac{\epsilon_{cu} (d_o - d_n)}{d_n} \quad 4.24$$

$$\sigma_{st} = \begin{cases} \epsilon_{st} E_s, & \text{for } \epsilon_{st} \leq \epsilon_y \\ f_y, & \text{for } \epsilon_{st} > \epsilon_y \end{cases}$$

The depth of the neutral axis is determined by trial and error procedure, similar to that given in Section 4.5.2.4, until the equation given below is satisfied.

$$T_p + T_s = C_c + C_s \quad 4.25$$

Taking moments about the non prestressed tensile reinforcement level gives:

$$M_{ur} = C_c l_c + C_s l_s - T_p l_p \quad 4.26$$

where C_c and C_s are magnitudes of the compressive force in the steel and concrete, respectively, and are therefore considered to be positive in the equation.

If the design strength is less than the design moment, the section is not adequate and additional reinforcement is required. In addition it is important to ensure that the section is ductile. To ensure ductility, the depth of the neutral axis at failure, d_n should be less than or equal to $0.3d_p$ [12].

If d_n is greater than this value, some additional non-prestressed compressive reinforcement has to be provided to reduce d_n . This will be a case of doubly reinforced cross-sections.

If the design strength M_{ur} is less than the design moment and if d_{n1} is small so that ductility requirement is fulfilled, the area of non- prestressed steel A_{st} may be obtained from Eq.4.27[9].

$$A_{st} \approx \frac{M_{ur} - M_{ur1}}{f_y l} \quad 4.27$$

where; M_{ur} is the required strength of the section

M_{ur1} is the strength of the section prior to the inclusion of additional steel

l is the lever arm between the tensile force in the additional steel T_s and equal and opposite compressive force C_{c2} which result from the increase in the depth of the compressive stress block.

The lever arm may initially be approximated as [9].

$$l = 0.9(d_0 - \gamma d_{n1}) \quad 4.28$$

where d_{n1} is the depth to the neutral axis corresponding to M_{ur1} .

If the inclusion of additional tensile reinforcement causes ductility problems, doubly reinforced cross - section result. The equal and opposite forces which result from the inclusion of the non-prestressed steel are:

$$T_s = A_{st}\sigma_{st} \quad \text{and} \quad C_c = A_{sc}\sigma_{sc} \quad 4.29$$

The minimum area of the tensile reinforcement is given by [4, 9].

$$A_{st} = \frac{M_u - M_{ul}}{\sigma_{st}(d_o - d_c)} \quad 4.30$$

where M_u the required strength of the doubly reinforced cross-section

M_{ul} -the strength of the singly reinforcement section

For conventional non-prestressed steel, $\sigma_{st} = f_y$ provided that the depth to the neutral axis d_n satisfies the stated ductility requirements.

From equilibrium, the forces in the top and bottom non-prestressed steel are equal and opposite, i.e. $C_s = T_s$ since $C_c = T_p$. From Eq.4.29,

$$A_{sc} = \frac{A_{st}\sigma_{st}}{\sigma_{sc}} \quad 4.31$$

If the depth of the natural axis is greater than about $0.3d_p$, the section is non-ductile and the value of d_n must be reduced.

4.6 DEFLECTION LIMITS

Deflection calculations are always carried out for prestressed members. It is not sufficient to check span-effective depth ratios as in a reinforced section. This is because the strength-to-stiffness ratio of a prestressed section is considerably greater than in a reinforced section. The effects of strand relaxation, creep etc. has greater effects as the degree of prestress increases.

The general method of curvature area may be adopted in pre-stressed design. For non deflected strands the curvature diagram is rectangular. Net deflection is found superposition of upward camber due to pretensioning and downward gravity loads.

Calculations are based on a flexurally un-cracked stiffness $E_c I$ using the transfer value E_{ci} for initial camber due to prestress and the final E_c and appropriate creep factor for long-term deflections.

Pre-camber deflection comprises of three parts:

- a) Short term value due to prestressing force P_i after initial elastic, strand relaxation

and shrinkage losses, plus;

- b) Long term value due to the prestressing force after all losses P_e and
- c) Self weight deflection

The Upward mid-span camber δ is calculated using the following equation [4,12,15]:

$$\delta = -\frac{p_i' e L^2}{8 E_{ci} I} - \frac{\Phi P_e e L^2}{8 E_c I} + \frac{5 w_o L^4 (1 + \Phi)}{384 E_c I} \quad 4.32$$

where, Φ is creep coefficient for the time interval.

W_o is the unit uniformly distributed self weight.

In-service long-term deflections (Δ) are calculated in the usual manner taking into consideration the support conditions, loading arrangement and creep. Service loads are used in the calculations. These deflections are limited to span/500 or 20mm where brittle finishes are to be applied, or span/350 or 20mm for non-brittle finishes. The net deflection (imposed minus pre-camber) should be less than span/1500 [12].

4.7 SHEAR CAPACITY

Hollow core slabs are designed for shear according to the same BS.8110:1997 Code provisions used in general for prestressed members. In dry cast systems, the normal practice is to not provide stirrups when the applied shear exceeds shear capacity because of the difficulty encountered placing stirrups in most production processes, the only reinforcement being longitudinal bars or pre-stressing strands. Therefore the shear capacity of these units depends on the shear resistance of the concrete in combination with dowel action alone.

An alternative used to increase shear capacity is to reduce the number of cores used in a given slab. This may be done by either leaving out a core for the entire length of a slab or by locally breaking into the cores and filling them solid while the concrete is still in a somewhat plastic state.

The provisions for shear as given in BS code are summarized as follow.

In pre-stressed sections shear capacity is calculated for two conditions

1. The flexurally uncracked section; and
2. The flexurally cracked section

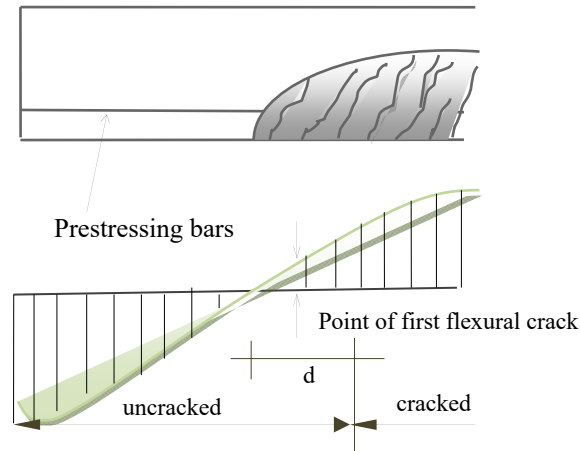

Figure 4.6 Shear resistances of pre-stressed elements

The ultimate uncracked shear resistance V_{co} is greater than the ultimate cracked value V_{cr} because the full section properties are considered and a small amount of diagonal tension in the concrete is permitted.

4.7.1 Shear Capacity in the Flexurally Uncracked Region

The ultimate shear capacity according to BS 8110 is given as [4, 9, 12]

$$V_{co} = 0.67 b_w D \sqrt{f_t^2 + 0.8f_{cp}f_t} \quad 4.33$$

where; f_t - tensile stress at the centroidal axis

$$f_t = 0.24 \sqrt{f_{cu}}$$

f_{cp} is the compressive stress at the centroidal axis due to prestress after all losses

b_w is for flanged section is taken as the web width (i.e. the narrower part)

D is the overall depth of the section.

f_{cu} is characteristic cube strength of the concrete

Although the above expression is derived using a rectangular section, it is used for non-rectangular section such as hollow core units with about 10% difference from the exact value [12]. But it is always on the conservative side.

In flanged sections where the centroidal axis is in the flange, equation 4.33 should be applied at the junction of the web-flange, i.e. f_{cp} is calculated there [9, 12].

The critical shear may occur in the prestress development zone where f_{cp} is not fully developed. It is known that prestressing forces develop parabolically and therefore a reduced value f_{cpx} is used [9].

$$f_{cpx} = \frac{x}{l_d} \left(2 - \frac{x}{l_d} \right) f_{cp} \quad 4.34$$

where l_d -the development length which is greater of the transmission length (l_t) or depth of section

x = is from the end of unit measured at 45° to the inner bearing edge.

The transmission length may be taken as [9, 12]

$$l_t = \frac{K_t \phi}{\sqrt{f_{ci}}} \quad 4.35$$

and $K_t = \begin{cases} 240 & \text{for standard or super strand} \\ 360 & \text{for drawn strand} \\ 400 & \text{for crimped wire} \\ 600 & \text{for plain or indented wire} \end{cases}$

where,

ϕ is the tendon diameter

f_{ci} is characteristic compressive strength of concrete at transfer

The shear resistance calculated for the flexurally uncracked region extends to a point one effective depth beyond the point at which the net flexural stress in the tension zone becomes zero, i.e. the decompression point where the applied moment $M_o = Z_b 0.8f_{cb}$ [12].

4.7.2 Shear Capacity in the Flexurally Cracked Region

In the flexurally cracked region shear resistance is a function of both the concrete and dowel action, as in reinforced concrete, plus a contribution of the level of compressive stress causing shear friction in the compressive zone. The shear resistance is computed from the formula [9, 12, 17].

$$V_{cr} = \left(1 - 0.55 \frac{f_{pe}}{f_{pu}} \right) V_c b_w d + M_o \frac{V}{M} \quad 4.36$$

$$\geq 0.1\sqrt{f_{cu}} b_w d$$

where, V is the design ultimate shear force at the section considered

M is the design ultimate bending moment at the section considered

$$M_o = Z_b 0.8f_{cb}$$

V_c is design concrete shear resistance given by:

$$V_c = \frac{0.79}{\gamma_m} \left[\frac{100(A_{st} + A_p)}{b_w d} \left(\frac{f'_c}{25} \right) \right]^{\frac{1}{3}} \left(\frac{400}{d} \right)^{\frac{1}{4}} \quad 4.37$$

where, $\frac{100(A_{st} + A_p)}{b_w d} \leq 3$; $\frac{400}{d} \geq 1$; $f'_c \leq 40\text{MPa}$; $\gamma_m = 1.25$

It is assumed that at a critical section the design shear force V cannot exceed V_{cr} , and so $V \leq V_{cr}$. Similarly, the ultimate design moment M cannot exceed M_u , therefore $M \leq M_u$. Thus, a unique value for V_{cr} exists as given below [4, 12].

$$V_{cr, \min} = \frac{\left(1 - 0.55 \frac{f_{pe}}{f_{pu}} \right) V_c b_w d}{1 - \frac{0.8Z_b f_{bc}}{M_u}} \quad 4.38$$

4.8 DESIGN GUIDE LINE

4.8.1 General

In general, the variables which must be established in the design of any statically determinate pre-stressed members are:-

- Shape and size of the section,
- The amount and location of both the prestressed steel and non-prestressed reinforcement, and
- The magnitude of the prestressing force.

In this section, the general procedures are given for the design of precast pre-stressed hollow core concrete floor units and demonstrated using example. Finally, a comparison is made between these kinds of floors and a solid slab.

4.8.2 Design Procedures for the Hollow Core Floor Units

The design procedure given below can be used to design fully prestressed hollow core floor units. Each of these steps is demonstrated by a practical example given in the next section.

- i-Determine the loads on the floor unit both at transfer and under the most sever load combination for the serviceability limit states. Hence determine the moments at the critical section both at transfer and under the full service loads M_o and M_T , respectively.
- ii-Choose an initial trial cross section using equation 4.16.
- iii-Estimate the time dependent losses and determine the pre-stressing force and eccentricity at the critical section.
- iv-Calculate both the immediate and time dependent losses. Ensure that the calculated losses are less than those assumed in step-3, if necessary.
- v-Check the deflection at transfer and the final long-term deflection under maximum and minimum loads. Adjust section size and or prestress level, if necessary.
- vi-Check the ultimate flexural strength at the critical section, If necessary, additional no prestressed tensile reinforcement may be used to increase strength and compressive reinforcement may be used to improve ductility, as required.
- Vii-Check the shear strength of the beam
- Viii-Check bearing capacity

In practice, standard cross sections and reinforcements are designed to provide for all combinations of floor loading and spans. Section sizes are selected at incremental depths, usually 50mm, and a set of reinforcement patterns are selected. Moment resistance, shear force resistance and flexural stiffness (i.e. deflection limit) are first calculated and then compared with design requirements. Most of the time, the floor units are partially prestressed. For this case the following steps can be followed

- i-Determine the design loads, moment and shear by choosing one trial section that fits from the standard cross-sections and reinforcements.
- ii- Determine the compressive and tensile stress limit both at transfer and working

- conditions. (Section 4.2)
- iii- Determine both the immediate and time-dependent prestress losses. (Section 4.4)
- iv- Check for flexural capacity (Section 4.5)
- a) Compute the serviceability moment of resistance of the partially pre-stressed member, M_{sr} , by using equation 4.7 and check for serviceability limit state of flexure. (Section 4.5.1)
 - b) Compute the ultimate moment of resistance, M_{ur} , and check for serviceability limit state of flexure. (section 4.5.2)
- v- Check for deflection limits. (Section 4.6)
- vi- Check for shear capacity (Section 4.7)
- a) Check for the shear capacity in the flexurally uncracked region (Section 4.7.1)
 - b) Check for the shear capacity in the flexurally cracked region. (Section 4.7.2)
- vii- Check the bearing capacity.
- Viii- Repeat the above steps if the selected section does not fulfill one of the checks given above by revising the section.

4.9 DESIGN EXAMPLE ON PRESTRESSED HOLLOW CORE SLAB SYSTEM

Using a typical floor slab shown in the figure 2.15, the floor constitutes eight prestressed precast hollow core concrete floor units of width 1.2m and length 5m. The floor carries a live load of 3kN/m^2 and a dead load of 2kN/m^2 in addition to its self-weight. Consider the finishes are non-brittle. The materials used in the floor are C-25 concrete and a prestressing standard strand of diameter 10mm. A relaxation loss 2.5% is to be taken as given by manufactures. The data required for the design are summarized according to BS.8110:1997 part 1 as follows.

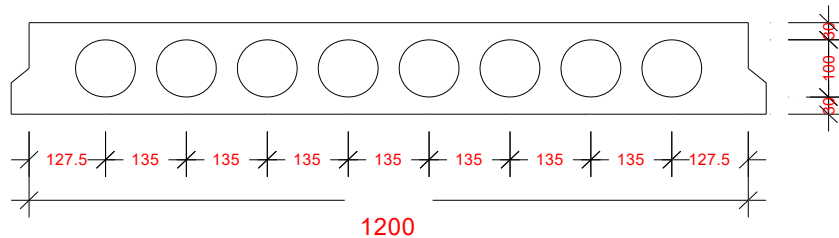

Figure 4.7 cross-section of hollow core floor slab

5m length and 1.20m width hollow core slab

Concrete C-25

Prestressing steel strand

$$f_{pu} = 1.750\text{kN/mm}^2 [9]$$

$$E_p = 195\text{kN/mm}^2 [9]$$

Step 1: Determine the loadings

Assuming overall depth 'D' of the cross-section is 240mm, the other dimensions are calculated below.

- Height of voids $\leq 240 - 50 = 190\text{mm}$Use $d_v = 180\text{mm}$
- Minimum flange thickness(t_f) = $1.6\sqrt{D} = 24.79\text{mm}$... Use 30mm for the top flange

3.9 Design example....

(Cont'd)

- Also use a thickness of 30mm for the bottom flange.
- Width of web $\geq 30\text{mm} \Rightarrow$ Use $t_w = 30\text{mm}$
- Width of hollow core slab $b=1200\text{mm}$

$$\text{Number of voids (n)} = \frac{1200 + t_w - d_{vf}}{t_w + d_v} = 5$$

Moment of inertia of the cross-section

$$I = \frac{bd^3}{12} - \left(\frac{\pi d_v^4}{64} \right) n$$

$$I = 1124750132\text{mm}^4$$

$$\text{Section modulus of the cross-section} = Z_b = Z_t = \frac{I}{C} = 9372917.77\text{mm}^3$$

Self weight of the floor unit

$$25\text{kN/m}^3 \left((0.24 \times 1.20) - 5 \left(\frac{\pi 0.18^2}{4} \right) \right) = 4.02\text{kN/m}$$

For a length of 5m:

The critical mid-span moment due to self weight is:

$$M_{sw} = \frac{4.02 \times 5^2}{8} = 12.56\text{kN-m}$$

The critical mid-span moments due to the superimposed dead and live loads are:

Due to dead load = $2 \times 1.20 = 2.40\text{kN/m}$

$$M_G = \frac{2.4 \times 5^2}{8} = 7.50\text{kN-m}$$

Due to live load = $3 \times 1.2 = 3.6\text{kN/m}$

$$M_Q = \frac{3.6 \times 5^2}{8} = 11.25\text{kN-m}$$

The critical mid span moment at transfer,

$$M_o = M_{sw} = 12.56\text{kN-m}$$

The critical mid span moment under the full loads

$$M_T = M_{sw} + M_G + M_Q = 31.31\text{kN-m}$$

Step 2: Initial trial section

From Eq. 4.16,

$$Z_b \geq \frac{M_T}{f_{tw} - \eta f_{ct}}$$

Where f_{tw} is tensile stress limit at service loads = 0

f_{ct} is compressive stress limit at transfer = 8.75N/mm²

f_{tt} is tensile stress limit at transfer = 1.00N/mm²

η is prestress loss factor = 0.75

$$\Rightarrow Z_b \geq 4771017.828\text{mm}^3$$

Since the section property $Z_b = 9372917.77\text{mm}^3$, the trial cross-section is ok.

Step 3: Prestressing force and eccentricity

The section properties are

$$A = 160765.50\text{mm}^2$$

$$I = 1124750132\text{mm}^4$$

$$Z_t = Z_b = 9372917.77\text{mm}^3$$

$$\alpha_u = \frac{A}{Z_t} = \alpha_b = \frac{A}{Z_b} = 0.01715$$

Equations 4.10, 4.11 and 4.13 becomes

$$\frac{1}{p_i} \geq \frac{\alpha_u e - 1}{A f_{tt}} \Rightarrow \frac{1}{p_i} \geq \frac{0.01715e - 1}{160765.50}$$

$$\frac{1}{p_i} \geq \frac{\alpha_b e + 1}{-A f_{ct}} \Rightarrow \frac{1}{p_i} \geq \frac{0.01715e + 1}{1406698.13}$$

$$\frac{1}{p_i} \leq \frac{\eta(\alpha_b e + 1)}{-A f_{ct} + \alpha_b M_T} \Rightarrow \frac{1}{p_i} \leq \frac{0.01715e + 1}{715955.33}$$

The plot of these three straight lines is shown in Fig.4.8 below.

The maximum eccentricity occurs at the intersection of Eqs. 4.10, 4.11 and 4.13 at $e = 45.5\text{mm}$.

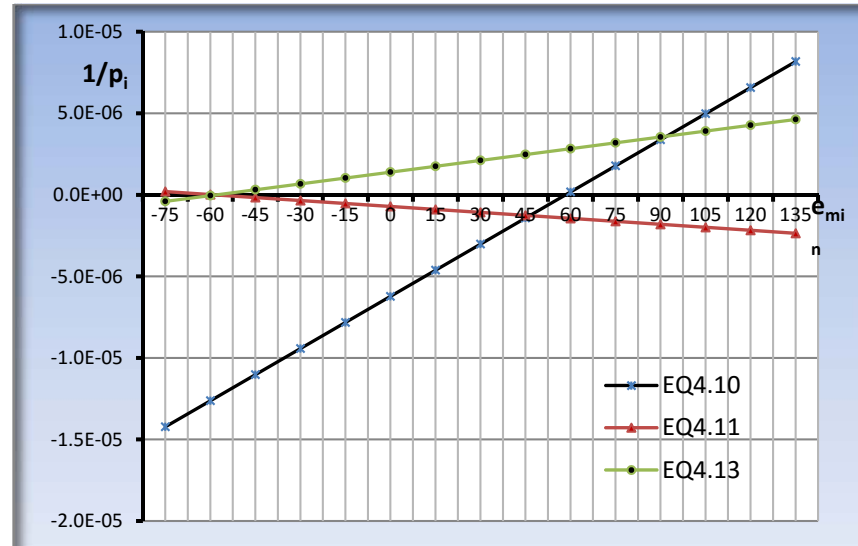

Figure 4.8 Design Diagram

The corresponding minimum pre stress p_i from Eq.4.13 is

$$p_i = \frac{-Af_{tw} + \alpha_b M_T}{\eta(\alpha_b e + 1)} = 402.17 \text{ kN}$$

The minimum number of strands, n , needed with $\phi = 10 \text{ mm}$

$$A = \frac{\pi \times 10^2}{4} = 78.50 \text{ mm}^2$$

$$A_p \approx 315 \text{ mm}^2$$

Assuming 5% immediate losses at mid-span, the minimum jacking force is

$$p_j = \frac{P_i}{0.95} = 423.37 \text{ kN}$$

The minimum number of 10mm diameter standard strand with cross-sectional area of 78.50 mm^2 is

$$n = \frac{P_j}{0.85 f_{pu} A} = 3.6, \text{ therefore take } 4 \phi 10 \text{ mm or}$$

Use $12 \phi 6$ standard strand with eccentricity $e = 45.5 \text{ mm}$ with $A_p = 315 \text{ mm}^2$

Step 4: Determine the pre-stress losses

The immediate losses are found using Eq.4.2:

$$\sigma_{cp} = -\frac{p_i}{A} - \frac{p_i e^2}{I} + \frac{M_o e}{I} = -2.734 \text{ N/mm}^2$$

The loss of stress in the steel due to elastic shortening is obtained from Eq.4.1:

$$\Delta\sigma_p = \frac{E_p}{E_c} \sigma_{cp} = -17.77\text{N/mm}^2$$

Therefore the loss of pre-stress at mid-span due to elastic shortening is

$$\Delta\sigma_p A_p = 5.58\text{kN} , \text{ which is approximately } 1.4\% \text{ of } P_i$$

Time dependent losses

a) Shrinkage loss is given by Eq.4.4:

$$\Delta\sigma_p = \varepsilon_{sh} E_p$$

where $\varepsilon_{sh}(t) = 300 \times 10^{-6}$ for normal conditions of indoor manufacture and exposure

$$E_p = 195\text{kN/mm}^2$$

$$\Delta\sigma_p = 300 \times 10^{-6} \times 195 = 0.0585\text{kN/mm}^2 = 58.5\text{N/mm}^2$$

$$\Delta\sigma_p A_p = 58.5 \times 314.159\text{mm}^2 = 18.38\text{kN} , \text{ which is approximately equal to } 4.6\% \text{ of } P_i$$

b) Creep loss is given by Eq.4.5:

$$\varepsilon_{ct}(t) = \frac{\sigma_c}{E_c} \Phi$$

where $\Phi =$ is the creep coefficient taken to be 2.

$$M_{sus} \text{ (Mid-span moment under the full sustained load)} = M_T = 31.31\text{kN/m}$$

$$\sigma_c = -\frac{p_i}{A} - \frac{p_i e^2}{I} + \frac{M_{sus} e}{I} = -1.98\text{N/mm}^2$$

The creep strain

$$\varepsilon_c(t) = \frac{\sigma_c}{E_c} \Phi = 0.132$$

Therefore, from Eq. 4.6:

$$\Delta\sigma_p = \varepsilon_c(t) E_p = 25.68\text{N/mm}^2 , \text{ which is approximately equal to } 2\% \text{ of } P_i$$

c) Steel relaxation loss

A relaxation loss of 2.5% is to be taken as given by manufacturers. Using a factor safety of 1.2, the relaxation loss is $(2.5\% \times 1.2) = 3\%$.

$$\sigma_{pi} = \frac{p_i}{A_p} = \frac{402.17\text{N} \times 10^3}{314.16} = 1280.16\text{N/mm}^2$$

Therefore, the relaxation loss will be

$$\Delta\sigma_p = 1280.16 \times \frac{3}{100} = 38.40\text{N/mm}^2$$

$$\Delta\sigma_p A_p = 38.40 \times \frac{314.159\text{mm}^2}{1000} = 12.065\text{kN}. \text{This is 3\% of } P_i$$

Total time dependent losses is given by

$$\Delta\sigma_p = 58.5 + 25.68 + 38.40 = 122.58\text{N/mm}^2$$

This value is less than the assumed value $0.25\sigma_{pi} = 1280.16 \times 0.25 = 320.04\text{N/mm}^2$.

Therefore, it is acceptable

Step 5: Check deflection

The precamber deflection is obtained from Eq.4.32:

$$\delta = -\frac{p'_i e L^2}{8E_c I} - \frac{\Phi P_e e L^2}{8E_c I} + \frac{5W_0 L^4 (1 + \Phi)}{384E_c I}$$

where Φ is creep coefficient

p'_i is prestressing force after initial elastic, relaxation and shrinkage losses

$$= P_i - (\Delta\sigma_p A_p + \Delta\sigma_p A_p + \Delta\sigma_p A_p)$$

$$= 402.17 - (5.58 + 12.06 + 18.39) = 366.14\text{kN}$$

P_e is the prestressing force after all losses

$$= 402.17 - (5.58 + 12.06 + 18.38 + 8.07)$$

$$= 358.08\text{kN}$$

$$\Phi = 2.00$$

$$W_0 = 4.019\text{kN/m}$$

The precamber deflection (δ) is -1.824mm

In service long-term deflection (Δ):

$$\Delta = \frac{5wL^4(1 + \Phi)}{384E_c I}$$

$$W = 5 \times 1.2 = 6 \text{ kN/m (due to dead and live load)}$$

$$\Delta = 4.34 \text{ mm} < 5000/350 = 14.29 \text{ mm} < 20 \text{ mm for non - brittle finishes.}$$

The net deflection (imposed minus precamber) will be

$$= (-1.824 + 4.341) = 2.52 \text{ mm} < 5000/1500 = 3.33 \dots \text{ok.}$$

Step 6: Ultimate flexural strength

The design load is

$$W_d = 1.4 \times (W_{sw} + W_G) + 1.6W_Q = 14.75 \text{ kN/m}$$

The design moment at the critical section is:

$$M_d = \frac{W_d l^2}{8} = 46.08 \text{ kNm}$$

The strain components in the prestressing steel is calculated from Eq.4.18 to 4.20

$$\varepsilon_{ce} = \frac{1}{E} \left(\frac{p_e}{A} + \frac{p_e e^2}{I} \right) = 0.0000962$$

$$\varepsilon_{pe} = \frac{P_e}{A_{ps} E_p} = \frac{358.08}{315 \times 195} = 0.005845$$

$$\varepsilon_{pt} = 0.0035 \left(\frac{d_p - d_n}{d_n} \right)$$

$$\varepsilon_{cu} = 0.0035$$

The strain in the prestressing tendon at the ultimate load condition is calculated from Eq. 4.21 is:

$$\varepsilon_{pu} = -9.621 \times 10^{-5} + 5.845 \times 10^{-3} + 0.0035 \left(\frac{d_p - d_n}{d_n} \right)$$

A simple check of horizontal equilibrium indicates that $0.9d_n$ is greater than $t=30\text{mm}$ from Eq.4.22.

$$C_{cf} = \frac{0.67 \times f_{cu} \times t \times b}{\gamma_m}$$

$$C_{cf} = \frac{0.67 \times 25 \times 30 \times 1200}{1.5} = 402.00 \text{ kN}$$

The web width is approximated to be $b_w = 300 \text{ mm}$

$$C_{cw} = \frac{0.67 \times f_{cu} (0.9d_n - t) \times b_w}{\gamma_m}$$

$$C_{cw} = \frac{0.67 \times 25(0.9d_n - 30) \times 300}{1.5} = 3.35(0.9d_n - 30)$$

The resultant compressive force is:

$$C = C_{cf} + C_{cw}$$

$$C = 402 + 3.35(0.9d_n - 30)$$

$$C = 3.01 + d_n + 301.50$$

The resultant tensile force is:

$$T = A_p \times \sigma_{pu} = 315 \times \sigma_{pu}$$

From equilibrium equation $C=T$

$$\sigma_{pu} = 0.0096d_n + 0.9597$$

Trial values of d_n may be used to determine ϵ_{pu} and σ_{pu} from the above equations as tabulated below and the resulting points are plotted on the stress-strain diagram. Note the stress-strain is done only for demonstration purpose.

Trial d_n (mm)	ϵ_{pu}	σ_{pu}	Point plotted On Fig.4.9
82	0.0108	1746.66	a
85	0.0105	1775.45	b
88	0.01105	1804.24	c

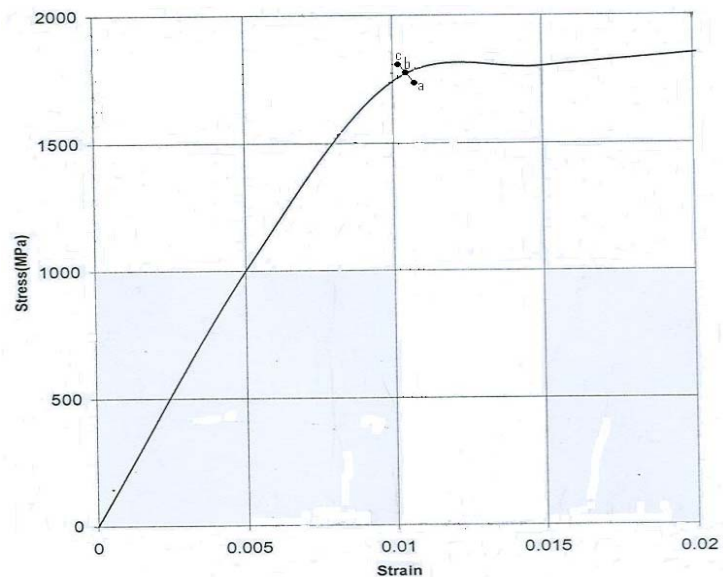

Figure 4.9 Stress -strain curve

3.9 Design example....

(Cont'd)

From Fig. 4.9, the natural axis is close to $d_n=85\text{mm}$, the depth of the stress block is $0.9d_n = 76.5\text{mm}$, which is greater than the flange thickness.

And the resultant forces on the cross-section are;

$$T = A_p \times \sigma_{pu} = 557.78\text{kN}$$

$$C_{cw} = 155.78\text{kN}$$

$$C_{cf} = 402.00\text{kN}$$

By taking moments of the internal compressive forces about the level of the tendons, $M_{ur}=86.73\text{kNm}$, which is greater than the design moment $M_d=46.08\text{kNm}$

$$M_{ur} = C_{cf} \left(d_p - \frac{t_f}{2} \right) + C_{cw} \left(d_p - t_f - \left(\frac{0.9d_p - t_f}{2} \right) \right)$$

$$M_{ur} = 402 \left(195 - \frac{30}{2} \right) + 155.78 \left(195 - 30 - \left(\frac{0.9 \times 195 - 30}{2} \right) \right) = 86.73\text{kN} > M_d$$

Step 7: Shear capacity

a) Shear capacity in the flexurally uncracked region

The compressive stress f_{cp} at the centrodal axis due to prestress after all losses is 2.23N/mm^2

$$b_w = 300.00\text{mm}$$

$$D = 240.00\text{mm}$$

$$f_t = 0.24\sqrt{f_{cu}} = 1.20\text{N/mm}^2$$

The transmission length is calculated using Eq.4.35:

$$K_t = 240.00 \text{ for standard or super strand}$$

$$\phi = 10\text{mm diameter}$$

$$f_{ci} = 17.50\text{N/mm}^2$$

$$l_t = \frac{k_t \phi}{\sqrt{f_{ci}}} = \frac{240 \times 10}{\sqrt{17.5}} = 573.71\text{mm}$$

The development length is greater of the transmission length, $l_t=573.71\text{mm}$ or depth of section, $D = 240.00\text{mm}$

Therefore take $l_d = 573.71\text{mm}$

The critical shear point $x = 100(\text{bearing assumed}) + 120 (\text{height to centroid}) = 220\text{mm}$

From Eq.4.34

$$f_{cpx} = \frac{x}{l_d} \left(2 - \frac{x}{l_d} \right) f_{cp} = 1.28 \text{ N/mm}^2$$

where

f_{cp} is the design stress at the end of the prestress development length l_d .

Therefore, the shear capacity in the flexurally uncracked region is obtained from Eq.4.33:

$$\begin{aligned} V_{co} &= 0.67 b_w D \sqrt{f_t^2 + 0.8 f_{cp} f_t} \\ &= 0.67 \times 300 \times 240 \times 10^{-3} \sqrt{1.20^2 + 0.80 \times 1.28 \times 1.20} \\ &= 78.86 \text{ kN} \end{aligned}$$

The maximum design shear at the critical section is $V=36.87\text{kN}$, which is less than shear capacity calculated above.

b) Shear capacity in the flexurally cracked region

The minimum value for V_{cr} is calculated from Eq.4.36:

$$M_o = Z_b 0.8 f_{bc} = 29.74 \text{ kNm}$$

$$\text{where, } f_{bc} = p_e \left(\frac{1}{A} + \frac{e}{Z_b} \right) = 3.965 \text{ N/mm}^2$$

$$\frac{f_{pe}}{f_{pu}} \approx 0.46$$

$$\frac{100(A_{st} + A_p)}{b_w d} = 0.582 \leq 3; \frac{400}{d} = 2.222 \geq 1; f'_c \leq 40 \text{ Mpa}; \text{ and } \gamma_m = 1.250$$

$$M_u = M_{ur} = 86.73 \text{ kNm}$$

$$v_c = \frac{0.79}{\gamma_m} \left(\frac{100(A_{st} + A_{ps})}{b_w d} \left(\frac{f'_c}{25} \right) \right)^{\frac{1}{3}} \left(\frac{400}{d} \right)^{\frac{1}{4}} = 0.64 \text{ N/mm}^2$$

Form Eq.4.37, the design concrete shear resistance is (Calculated from step 6 above)

$$V_{cr} = \frac{\left(1 - 0.55 \frac{f_{pe}}{f_{pu}}\right) v_c b_w d}{1 - \frac{0.8Z_b f_{bc}}{M_u}} = 39.67 \text{ kN which is greater than } V \dots \text{ok}$$

According to the above computation the following summarized outputs are stated below for 5.00m length and 1.20m wide hollow core floor slab.

Concrete class	Depth (mm)	No of voids	Depth of voids	Area of the section (mm ²)	Moment of inertia (mm ⁴)	Prestress strands
C-25	240	5	180	160765.50	1124750132	12 Ø 6
C-30	230	5	170	162509.97	1011708625	12 Ø 6
C-40	200	6	140	147637.18	686855540.6	16 Ø 5

Table 4.1 Summarized values for different concrete classes

CHAPTER 5

COST COMPARISON

As the main objective of this study is to investigate the advantages of the use of prestressed hollow core slab elements with the precast beam-block slab constructions, this section deals with cost comparison of the two systems

The cost comparison is divided in to two components, the first is construction cost component, and the second one is construction time component.

5.1 CONSTRUCTION COST COMPONENTS

In this section, the cost of construction (Material, Labor and equipment including profit and overhead costs), using the two slab systems of four-story building is calculated.

Disposition of cost calculation

Direct cost + Indirect costs = Bid sum

Direct cost + Site overhead cost = Production cost

Production cost + General overhead cost = Self-costs

Self costs + Risk and profit = Bid sum

i) Direct costs

a) Material costs

- Quantity
- Loading, unloading and transportation costs
- Wastages

b) Labor costs

- Standard wages
- Extra pay

c) Equipment costs

- Ownership of plant
- Hire of plant

ii) Indirect costs

- a) Site overhead costs
- b) General overhead costs
- c) Risk and profit

In this study the overheads, risk and profit are considered as 25% of the direct costs.

5.1.1 Quantities of Materials

Information's required are:

- Quantity of material required to produce a unit amount
- Basic price at the source of material
- Transport, loading and unloading to the site
- Waste/loss

The quantities of materials required for the construction of the floors, in both systems, are calculated referring the layout plans on Figs. 2.1 and 2.15

5.1.1.1 Material quantity of precast beam-block slab system

Materials

- Concrete = $0.088\text{m}^3/\text{m}^2$
Floor Slab: $9.34 \times 6(0.088 \times 5.00) = 24.66\text{m}^3$
- Reinforcement

ϕ 6 c/c spacing 300mm for one floor slab:

$$\text{Mass} = 0.222 (30 \times 32 + 101 \times 9.5) = 426.13\text{kg}$$

- Slab HCB

Number of Slab HCB Per one floor

$$14 \times 6 \times \left(\frac{4.8}{0.2} \right) = 2016\text{pcs}$$

The cost of Slab-HCB, used in this study, is taken from Kality Construction and Construction Materials Production Enterprise (KCCMPE) and Prefabricated Building Parts Production Enterprise (PBPPE) selling price.

Therefore, the total cost of class ‘A’ Slab-HCB including transportation, loading and unloading is 6.95birr/pc.

- Precast beam elements

$$\text{Total number of precast beams in one floor slab: } 6 \times \left(\frac{9.00}{0.60} + 1 \right) = 96 \text{ pcs}$$

- 2mm thick ceiling plastering

Total area of one floor ceiling plastering

Assuming 10% of the ceiling covered by partitions wall

$$6 \times 0.9 \times (5.00 \times 9.00) = 243 \text{ m}^2$$

- Formwork cost is estimated as follows; using sheet metal

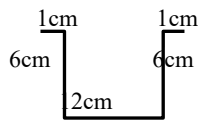

Formwork cost for one precast beam where, length of beam is 5m

material current price (2m × 1m × 2mm sheet metal) = 300 birr/pcs

Development length = (2 × 6cm) + 12cm + (2 × 1cm) = 26cm

$$\text{Material cost} = 0.26 \left(\frac{5.00}{2} \times 300 \right) = 195.00$$

Indirect cost is 25% of Labor and equipment cost = 48.75

Total cost = 243.75 birr/pc

Since the production of precast beam elements can be performed on a level ground, it can be used for many times without being damaged. Assuming 12 usage of the steel formwork,

$$\text{Direct cost} = \frac{243.75}{12} = 20.31 \text{ birr/pc}$$

The quantity of materials used for precast beam element, per one piece, is estimated as follow:

Length of precast beam element is 5m

Volume of concrete per one precast beam element is $0.06 \times 0.12 \times 5.0 = 0.036 \text{ m}^3$

Reinforcement

$$\phi 6 \text{ length} = 2 \times 23.5 + 8 + 5 = 60 \text{cm (length for one stirrup)}$$

$$\text{Total length for one piece} = \left(\frac{5.00}{0.15} + 1 \right) \times 0.60 = 20.60 \text{m}$$

Mass,

$$\text{Shear re-bar} \dots \phi 6 = 0.222 \text{kg/m} \times 20.60 \text{m} = 4.57 \text{kg}$$

$$\text{Top re-bar} \dots 1 \phi 14 = 1.208 \text{kg/m} \times 5.00 \text{m} = 6.04 \text{kg}$$

$$\text{Bottom re-bar} \dots 2 \phi 16 = 1.577 \text{kg/m} \times 2 \times 5.00 = 15.77 \text{kg}$$

$$\text{Total mass} = 26.38 \text{kg}$$

Labor costs

Required information for the calculation of labor cost

- Number and type of skilled and unskilled manpower for a particular type of work, (crew)
- Performance of crew per hour for a unit amount of work.
- Indexed hourly cost of the workmanship.
- Utilization factor (UF) of the workmanship: Share of a particular personal per hour for the specified work

Equipment costs

Required information for the calculation of equipment cost

- Type of equipment for a particular item of work.
- Performance of equipment per hour for a unit amount of work (production rate)

Two methods of calculation are known.

- i) With charges accounted for depreciation, interest return and monthly repair costs
- ii) With monthly/hourly rental charges and it is considered in this study.

Table 5.1 Calculation of total production cost of one precast beam elements

Materials	Unit	Quantity	Cost per unit* birr/unit	Cost per one pcs
1-Concrete	m ³	0.036	828.78	29.84
2-Reinforcement				
a)diameter 6	kg	4.57	17.20	78.60
b)Diameter 14	kg	6.04	17.20	103.88
c)Diameter 16	kg	15.77	17.20	271.24
3-Steel formwork	Pcs	1.00	20.31	20.31
4-Welding	Joints	34.00	0.20	6.80
Direct cost				510.67
25% (profit and overhead)				127.66
Total cost (birr/pc)				638.34

* The cost per unit of concrete and reinforcement is taken from appendix A Tables 5.10 and 5.11

5.1.1.2 Material quantity of hollow core floor slab system

- Length of hollow core slab = 5.00m
- Width =1.20m
- Total depth of hollow core slab = 0.24m
- Number of voids =5
- Depth of void = 0.18m
- Number of slab required for one floor is 48pcs

Materials for Hollow core slab

- Concrete

Volume of concrete for one hollow core slab

$$5 \left(1.2 \times 0.24 - \frac{5 \times \pi \times 0.18^2}{4} \right) = 0.804 \text{m}^3 \text{ per one hollow core slab}$$

Total volume of concrete required for one floor

$$48 \times 0.804 = 38.59\text{m}^3$$

- 35mm thick topping provided on the top of hollow core slab

Total volume of topping concrete required for one floor

$$30 \times 9.50 \times 0.035 = 9.98\text{m}^3$$

- Prestressing wire

12 ϕ 6 prestressing wires

- Plane reinforcement for topping work

ϕ 6 c/c spacing 300mm

Weight

$$0.222\text{kg/m} (30\text{m} \times 32 + 101 \times 9.5\text{m}) = 426.13\text{kg}$$

Table 5.2 Calculation of total production cost of one hollow core floor slab

Materials	Unit	Quantity	Cost per unit * birr/unit	Cost per one pcs
1-concrete including formwork	m ³	0.804	992.48	797.95
2-Diameter 6 Prestressing wire	kg	16	35.26	564.16
Direct cost				1362.11
25% (profit and overhead cost)				340.53
Total cost (birr/pcs)				1702.64

*:-The cost per unit of prestress strand and concrete is taken from appendix A tables 5.14 and 5.15 respectively.

Table 5.3 Construction cost of topping in the first floor

Materials	Unit	Quantity	Cost per unit * (birr /unit)	Total cost in birr
1-Concrete	m ³	9.98	828.78	8271.22
2-Reinforcement Ø6mm	kg	426.13	17.20	7329.45
Direct cost				15600.67
25% profit and overhead cost				3900.17
Total cost (birr/unit)or per floor				19500.84

* :-The cost per unit of concrete and reinforcement is taken from appendix A Tables 5.10 and 5.11

Table 5.4 Construction cost of hollow core slab in the first floor

Materials	Unit	Quantity	Cost per unit* (birr /unit)	Total cost in birr
1-Production and construction	pcs	48	1858.54	89209.92
2-Topping				15600.67
Direct cost				104810.59
25% profit and overhead cost				26202.65
Total cost (birr/unit)				131013.24

* :-The cost per unit of installation of hollow core slab in the first floor is taken from appendix A Tables 5.16(a)

:-The direct cost of topping construction in the first floor is taken from table 5.3

Table 5.5 Construction cost calculation using precast beam-block slab system in the first floor

Materials	Unit	Quantity	Cost per unit (birr/unit)	Total cost in birr
1-Production and construction cost	pcs	96.00	652.93	62681.28
2-Slab HCB	pcs	2016	9.02	18184.32
3-Diameter 6 reinforcement	kg	426.13	17.20	7329.44
4-Concrete work cost	m ³	24.66	827.36	20402.70
5-Support Work	pcs	96.00	19.33	1855.68
6-2mm thick ceiling plastering	m ²	243.00	42.20	10254.60
Direct cost				120708.02
25% profit and overhead cost				30177.01
Total cost (birr/unit)				150885.03

Cost per unit of installation of precast beam, slab HCB, reinforcement, concrete, support and 2mm thick ceiling plastering works are taken from appendix A table 5.12(a),5.13(a),5.10,5.11(a),5.18 and 5.17 respectively.

Cost comparison

Table 5.6 Summary of cost comparison for both precast beam-block slab and prestressed hollow core floor slab

Floor	Precast beam-block Slab cost in birr			Prestressed hollow core slab cost in birr			Difference in cost (birr)
	Direct cost(a)	Indirect cost(b)	Total c= a + b	Direct Cost(d)	Indirect Cost (e)	Total f= d+ e	
1 st	120708.02	30177.01	150885.03	104810.59	26202.65	131013.24	19871.79
2 nd	121253.68	30313.42	151567.10	105879.55	26469.88	132349.44	19217.66
3 rd	122112.35	30528.09	152640.44	107305.15	26826.29	134131.44	18509.00
4 th	123300.84	30825.21	154126.05	109300.51	27325.13	136625.64	17500.41
Total	487374.89	121843.73	609218.62	427295.80	106823.95	534119.76	75098.86

Form the above table the difference in the total cost between the two systems is 75,098.86 birr.

$$\text{Total area of floors} = 4 \times 0.00 \times 9.50 = 1140 \text{m}^2$$

Hence the saving per floor area, from construction cost is,

$$= \frac{75,098.86}{1140} \cong 65.90 \text{birr/m}^2$$

5.2 CONSTRUCTION TIME COMPONENT

Table 5.7 summarizes areas where costs are generated on site for a particular item. Naturally the most important cost saving is that of time. The use of hollow core floor slab system allows for immediate access to the floor below than precast beam-block floor system.



Figure 5.1 Use of hollow core slab on concrete framed building.

Table 5.7 Pricing items for comparing the two different flooring systems

Activity	Beam and block	Prestressed hollow core
Time related costs	*	
Precast material delivery to site	*	**
Erection of material	*	incl. above
Propping	(*)	
Reinforcing steel	*	
Concrete (incl. placing)	*	
Plastering soffit	*	

* Item needs pricing, ** Price normally includes supply and erection, (*) This item may need pricing

It is known that the major advantage of using prestressed hollow core slab elements for construction is the speed of construction, i.e. the use of this system saves construction time. Since construction time delay is one of the main causes of claims in the construction industry, the use of hollow core systems is believed to solve this problem, in addition to cost saving.

In this section, the advantage of the prestressed hollow core slab system over the precast beam-block slab system with regard to construction speed will be shown by the critical path method of construction schedule technique. In most construction activities, a number of crews are involved in particular activity to speed up the rate of construction, provided that, the contractor is capable of providing the necessary equipment and there is enough working area. For the purpose of comparison, in this research two crews are assumed to participate in each activities respectively, in both systems, i.e. the total output will be two times those in appendix A, tables 5.10 through 5.18.

5.2.1 Hollow Core Slab System

Table 5.8 Construction schedule using hollow core slab system

Activity	Designation	Quantity	Output/1crew	Out put per 2crew	Duration (days)	Job logic
Hollow core slab	HCs	192pcs	26pcs/day	52pcs/day	4	1-2
Slab reinforcement	SR	1704.52kg	96kg/day	192kg/day	9	1-3 & 3-5
Topping	TP	39.92m ³	14.40 m ³ /day	28.80 m ³ /day	2	1-4 & 4-5

The network diagram is as shown below

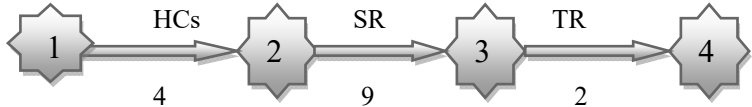

Figure 5.2 Network diagram of slab construction using pre stressed hollow core slab system.

Form the above network diagram, the project duration for the slab construction, using this slab system is 15 days.

5.2.2 Precast beam-block slab system

Table 5.9 Construction schedule using precast beam-block slab system

Activity	Designation	Quantity	Output/1crew (Avg)	Output per 2crew	Duration (days)	Job Logic
PCB work	PCB	384pcs	13pcs/day	26pcs/day	15	1-2
HCB work	HCB	8064pcs	128pcs/day	256pcs/day	32	1-3
Reinforcement	SR	1704.52kg	96kg/day	192kg/day	9	3-4
Concrete work	C	98.64 m ³	14.40m ³ /day	28.80m ³ /day	4	4-5

The network diagram is as shown below

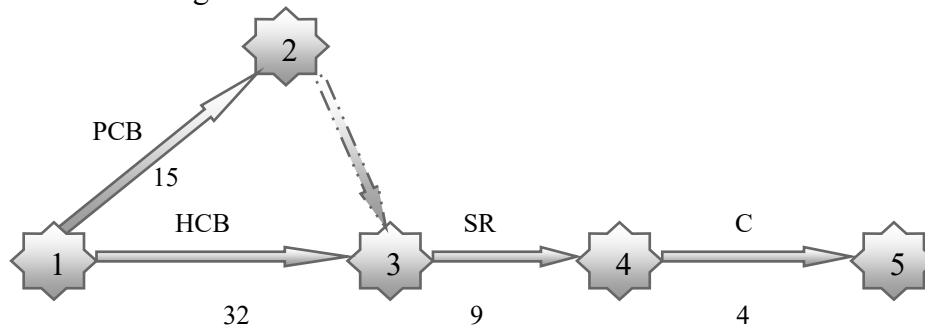

Figure 5.3 Network diagram of slab construction using precast beam-block slab system.

From the above network diagram, the project duration for the slab construction using precast beam-slab system is 45 days.

As it can be clearly seen from the network diagrams of the two systems, the construction time saving by using the precast prestressed hollow core slab system is 30 days. This means the hollow core slab system of construction will take only 33% of the time taken by the precast beam slab system.

The current rental cost of buildings, on average, is about 85 birr/m²/ month. The owner of a building project will be benefited this sum, if the project is completed before the anticipated project duration. Hence the saving gained from the speed of construction may be converted to financial value as:

$$\begin{aligned}\text{Saving from construction time} &= \frac{30}{30} \times 85.00\text{birr/m}^2 \\ &= 85.00\text{birr/m}^2\end{aligned}$$

The total cost of saving is the sum of the saving from construction cost and construction speed.

$$\begin{aligned}\text{Total saving} &= 65.90+85.00 \\ &= 150.90\text{birr/m}^2\end{aligned}$$

The current total construction cost of building projects using the precast beam slab systems is estimated to be about 2500.00 birr/m² this means the total saving obtained from the use of prestressed hollow core slab system is about 6.04% of the total construction cost.

CHAPTER 6

CONCLUSION AND RECOMENDATION

The use of a relatively cheaper system of construction for building construction instead of the widely used ones, will not only have economical benefits but also avoids the dependence on usual systems, thereby reducing the competition in the construction industry. Precast prestressed hollow core slab system of construction is a system, which does not need very heavy equipment for erection, and the component members can be produced with locally abundant construction materials.

In addition it is a precast, prestressed concrete slab system with continuous voids provided to reduce weight and, therefore, cost and, as a side benefit, to use for concealed electrical or mechanical runs. Primarily used as floor or roof deck systems, hollow core slabs also have applications as wall panels, and bridge deck units.

It should be understood that the main objective of the present study is to investigate the advantage of pre cast prestressed hollow core slab elements for floor slab construction, by comparing with the precast beam-block slab system. All construction projects are designed to end up with an optimum economy and safety. To fulfill these criteria the construction method to be adopted should be the one with minimum total cost that satisfies the strength requirements.

A cost comparison between the two systems of construction the hollow core slab system and the precast beam slab system was made by designing the floor slabs of a typical four-story building, using both systems.

Based on the cost comparison, the theoretical investigation the following conclusions and recommendations may be drawn.

1. The cost comparison shown that the hollow core slab system of construction is faster and less expensive than the precast beam-block slab system. The total saving obtained from the use of system is about 6.04% of the total construction cost of a building using the precast beam-block slab systems. In addition to the economical benefits gained the application of this system is believed to solve problems associated with delays in the construction industry, since construction delays are one of the main causes of disputes.

2. As it can be seen from the cost comparison the saving from construction cost component is 44% of the total saving. Higher value of construction cost saving and hence total saving could have been obtained if the precast pre-stressed hollow core slab elements are designed and produced more economically
3. For the production of the precast prestressed hollow core slab elements. it is recommended to use a minimum concrete class C-25 and the upper surface of the slab elements should be sufficiently roughened to create a good bond with the floor finish cement screed or structural topping and the lower surface slab surface should be smooth enough for final painting. The top surface is generally prepared to receive a screed or structural topping. Because they are cast against a steel surface, the soffits are smooth and ready to receive a decorating finish direct without the need for plastering.
4. During handling, transporting and erecting the hollow core slab elements great care should be taken not to impair some structural properties. A minimum of two-point lifting mechanism is recommended to use as shown in Fig. 5.4 below.



Figure 5.4: Hollow core slab being hoisted into Position.

5. For a country like Ethiopia, where timber and eucalyptus poles resource are limited the application of this system of construction not only has economical benefits but also preserves the national resource by avoiding excessive use of formwork and scaffolding.
6. Finally, it is believed that the result of this study are encouraging and has shade light into the introduction of precast pre-stressed slab systems in the construction industry. However, it is suggested that further research be carried out in this area for proper utilization of the system. It is hoped that the present study serve as an aid for further developments and other related studies.

REFERENCES

1. Arthur H. Nilson 1987. *Design of prestressed concrete*, 2nd edition. Canada: John Wiley and Sons.
2. Ben C. Gerwick, Jr 1971. *Construction of prestressed concrete structures*. New York: Wiley inter-science.
3. Biruh Habtu 2005, *Precast prestressed hollow core concrete floor slabs*. MSc. thesis: school of graduate studies, Addis Ababa University of technology faculty.
4. British standard (BS) 8110 1997. *Structural use of concrete, part 1, code of practice for design and construction*. London: British standards institution.
5. Chudley R. 1996. *Construction technology*, 2nd edition. England : Longman group limited.
6. Dharris J. and Smith I.C. 1963. *Basic design and construction in prestressed concrete* London: Chatto and Windus
7. Donald R. Buettner and Roger J. Becker 1998. *Prestressed hollow core concrete slab design manual*, 2nd edition. U.S.A. Precast prestressed concrete institute, Chicago.
8. Fredrick S. Merritt, M.Kent Loftin. and Jonathan T. Ricketts 1996. *Standard hand book for civil engineers*, 4th edition. New York: McGraw-Hill
9. Gilbert, R.I. & N.C. 1990. *Design of prestressed concrete*. London: Academic Division of Unwin Hyman Ltd.
10. Kenneth Leet 1991. *Reinforced concrete design*, 2nd edition. U.S.A.: McGraw-Hill.
11. Kent Preston H. and Norman J. Sollenberger. 1967. *Modern prestressed concrete*. New York : McGraw-Hill
12. Kim S. Elliott 2002. *Precast concrete structures construction*. Oxford, Boston: Butterworth-Heinemann.
13. Libby James R. 1971. *Modern prestressed concrete design principles and construction methods*. New York: Van Nostrand Reinhold co.
14. Lin, T.Y and Ned H. Burns. 1982. *Design of prestressed concrete structures*, 3rd edition. Canada: John Wiley and Sons.

15. Mallick and Rangasami 1977. *The mechanics of prestressed concrete design*, 3rd edition. Delhi: Khanna Publishers.
16. Michael Chi and Frank A. Bibestein 1963. *Theory of prestressed concrete*. Englewood Cliffs, New Jersey: Prentice-hall inc.
17. Ramaswamy G.S. 1978. *Modern prestressed concrete design*. London: Pitman publishing limited.
18. Robert A. Hartland 1975. *Design of precast concrete: an introduction to practical design*. London: Survey university press: International text book Co.
19. Tihamer Koncz Dr. Ing. 1968. *Manual of precast concrete construction*. Germany: Bauverlag Gmb H. Wiesbaden and Berlin.
20. Bison. *Hollow core floors for multiple occupancy housing*, UK: Bison concrete products limited. 2007 from:
<e-mail: concrete@ bison.co.uk, web site: www.bison.co.uk.>
21. **Concrete Manufacturers Association** 1996. *Precast concrete floor slabs design manual*, Randburg: The association < e-mail: cma@cis.co.za, website: www. cma.org.za>
< http://www.cma.org.za/UploadedMedia/precast_concrete_floorslab%5B1%5D.pdf>
22. Old castle precast building systems division. 2007, from:
<http://www.oldcastlesystems.com>
23. *Precast prestressed hollow core slab hand book* 2006, PNK Enterprise Co., Ltd. Retrieved 2007, from <http://www.pankmarkering.com/web/contact.php>
24. Quick cell technology Products Pty. Ltd. Retrieved 2007, from
< http://www.quickcelltechnology. com/products.?prod=lipf>
25. Structural floor and roof systems precast prestressed concrete technical brochures Canada: precast prestressed concrete institute. Retrieved 2007, from
< http://www.cpci.ca/downloads/structural_floor_and_roof.pdf >

DECLARATION

I, the undersigned, declare that this thesis entitled “**COMPARISON OF PRECAST-HCB SLAB SYSTEM AND PRE-STRESSED HOLLO CORE CONCRETE SLAB SYSTEM**” is my original work and has not been presented for a degree in any other university and that all sources of material used for the thesis have been duly acknowledged.

Name: _____

Signature: _____

Place: Faculty of Technology, Addis Ababa University

Date of Submission: June 2008

