



ADDIS ABABA UNIVERSITY

ADDIS ABABA INSTITUTE OF TECHNOLOGY

ELECTRICAL AND COMPUTER ENGINEERING DEPARTMENT

Optimized Line Amplifier Placement for Energy Saving: a Case Study of ethio telecom Optical Backbone Network

A Thesis Submitted to the School of Electrical and Computer Engineering of Addis Ababa University in Partial Fulfillment of the Requirements for the Degree of Master of Science in Telecommunication Network Engineering

By: Aselef Teka

Advisor: Dr. Yalemzewd Negash

February, 2020

Addis Ababa, Ethiopia

ADDIS ABABA UNIVERSITY
ADDIS ABABA INSTITUTE OF TECHNOLOGY
ELECTRICAL AND COMPUTER ENGINEERING DEPARTMENT

**Optimized Line Amplifier Placement for Energy Saving: a
Case Study of ethio telecom Optical Backbone Network**

By: Aselef Teka

Approval by Board of Examiners

Dr. Yalemzewd Negash

Dean, School of Electrical & Computer Engineering

Signature

Committee

Dr. Yalemzewd Negash

Advisor

Examiner

Examiner

Signature

Signature

Signature

Declaration

I, the undersigned, declare that this thesis is my original work, has not been presented for fulfillment a degree in this or any other universities, and all sources of materials used for the thesis work is duly acknowledged.

Aselef Teka

Name

Signature

Place: Addis Ababa, Ethiopia

Date of Submission: December 19, 2020

This thesis has been submitted for examination with my approval as a university advisor.

Dr. Yalemzewd Negash

Advisor's name

Signature

Abstract

In recent years, traffic volume is increasing tremendously. In line with this increment, telecom operators expand their network infrastructure. This increases power consumption of the network. Especially in a backbone network, where power consumption is dependent on traffic volume, the increase in power consumption is becoming critical.

Researchers are made efforts dedicated to reduce unnecessary energy waste in backbone networks using physical topology optimization for highly connected networks, but this optimization is not feasible for low connected networks like ethio telecom. In addition, line amplifiers are placed at regular interval of 80km without considering physical and economic restrictions. In practice, amplifier placement is commonly implemented by operators to guarantee a signal quality considering placement location with availability supply power, shelter, and physical security with the expense of high power consumption. Current ethio telecom line amplifiers are placed at span length ranging from 25 to 120km considering these physical and economic restrictions; due to this, ethio telecom is subjected to high power consumption in line amplifiers.

In this thesis, optimized line amplifier placement, which takes power consumption and physical and economic restrictions in to account is investigated. Mixed Integer Linear Programming (MILP) formulation which takes span length and input power level constraint is proposed. The proposed power-saving approach is evaluated considering ethio-telecom North circle optical backbone network topology. MATLAB is used to assign optimum placement location. The result is compared with theoretical standard (80km spacing) and the practical (ethio telecom current deployment scenario) using number of amplification sites and power saving performance. The comparison results show that amplifier site placement using the new approach can minimize the number of amplification sites by 9 from the theoretical approach and by 5 from the existing configuration and a 2% power saving can be achieved in the case study network portion.

Key words: - Amplifier placement, Energy saving, Optimization, physical layer parameters.

Acknowledgement

First of all, I would like to thank the almighty God for everything in my life.

Secondly, I would like to express my grateful gratitude and sincere appreciation to my advisor Dr. Yalemzewd Negash to the guidance, encouragement, constructive comments, valuable advice and kindness to me throughout this study. The success of this thesis is credited to the extensive support and assistance from him.

Thirdly, I would like to thank all my family who always supported me. Especially, I am certain that without the encouragement of my brother Gashaw. T, I would not have been able to achieve this goal. Thanks also to my daughter Beimnet for her unconditional love.

Also special thanks to Kedir, Yohannes & Bezuayehu for all their help. They have always been willing to discuss any problem with me and give me valuable feedback and suggestions.

Fourthly, I would also like to thank ethio telecom for giving me the opportunity to carry out my M.sc study.

Finally, my special thanks to ethio telecom RAN and National Transmission managers and supervisors: Mr. Abebe, Mr.Berehanu and Mr.Merga ; who helped me in providing necessary information and materials that help me during my research and give me their valuable support through my study.

Table of Contents

Abstract	i
Acknowledgement.....	ii
List of Figures	v
List of Tables.....	vi
List of Abbreviations/Acronyms	vii
CHAPTER 1: Introduction	1
1.1 Background	1
1.2 Literature Review	4
1.3 Motivation	5
1.4 Problem Statement.....	7
1.5 Objectives.....	7
1.5.1 General objective	7
1.5.2 Specific objectives	7
1.6 Methodology	8
1.7 Scope.....	8
1.8 Contribution of the Thesis.....	8
1.9 Organization of the Thesis	9
CHAPTER 2: Overview of Optical Transport System.....	10
2.1 Introduction	10
2.2 WDM System	10
2.3 Physical Impairments.....	13
2.4 Optical Amplifiers	15
2.4.1 Semiconductor Optical Amplifiers	17
2.4.2 Optical Fiber Amplifiers	18
2.5 Component Placement in a Link	22

CHAPTER 3: Energy Consumption of Optical Networks	25
3.1 Introduction	25
3.2 Component Power Consumption.....	25
3.3 Power Consumption Minimization Approaches	27
CHAPTER 4: Research Methodology.....	30
4.1 Experimental Network Topology	31
4.2 Data Analysis	32
4.3 Optimal Line Amplifier Placement	36
4.4 Problem Formulation	37
CHAPTER 5: Results and Discussions	43
5.1 Amplifier Placement Results.....	43
5.1.1 Placement Result of New Approach	45
5.1.2 Placement Result of 80km Interval.....	48
5.2. Power Consumption Analysis Results	50
5.2.1 Power Consumption Analysis Result of New Approach.....	50
5.2.2 Power Consumption Analysis Result of 80km Interval	50
5.2.3 Power Consumption Result of Existing Configuration	51
5.3 Discussion	52
5.3.1 Power Consumption Contribution	52
5.3.2 Power Saving Performance	54
5.4 Implementation Strategy	56
CHAPTER 6: Conclusion and Future Work	57
6.1 Conclusion.....	57
6.2 Future works.....	58
References.....	59

List of Figures

Figure 1.1: Energy consumption trend of telecommunication networks [5, 6].....	2
Figure 2.1: Components of the WDM system [15]	11
Figure 2.2: IP over WDM system [3]	12
Figure 2.3: Optical amplifier functions [27]	17
Figure 2.4: Saturated amplifier gain G as a function of the output power [13].....	19
Figure 2.5: EDFA cards [27].....	22
Figure 4.1: Topology of North-East optical backbone network [10]	32
Figure 4.2: Representation of a physical link.....	39
Figure 5.1: New network topology.....	48
Figure 5.2: Total segment power consumptions	53
Figure 5.3: Power consumption contribution of amplification sites	54

List of Tables

Table 3.1: Power consumption of transponders [30]	26
Table 3.2: Power consumption of OXC/ROADM [30]	26
Table 4.1: Power consumption of main optical components	32
Table 4.2: OADM site typical configuration and component power consumption [10].....	33
Table 4.3: OLA site component power consumption[10]	34
Table 4.4: Notations and descriptions of input parameters	38
Table 4.5: Decision variable notation and description.....	38
Table 5.1: Distance between two pre-defined locations	44
Table 5.2: Sample amplifier placement problem solution.....	45
Table 5.3: Amplifier placement results of the new approach	47
Table 5.4: Amplifier placement analysis result for 80km interval.....	49
Table 5.5: Result Summary.....	52

List of Abbreviations/Acronyms

ASE	Amplified Spontaneous Emission
ASON	Automatically Switched Optical Network
ATM	Asynchronous Transfer Mode
BTS	Base Trans-Receiver Station
dB	Decibel
DCM	Dispersion Compensation Module
DSF	Dispersion Shifted Fiber
DWDM	Dense Wavelength Division Multiplexing
EDF	Erbium-Doped Fiber
EDFAs	Erbium-doped fiber amplifiers
GHG	Green House Gas
HLD	High Level Design
ILP	Integer Linear Programming
IP	Internet Protocol
ITU-T	International Telecommunication Union-Telecommunication
LLD	Low Level Design
LP	Linear Programming
MILP	Mixed Integer Linear Programming
NF	Noise Figure
NSFNET	National Science Foundation Network
OADM	Optical add/Drop Multiplexers

O-E-O	Optical- Electrical-Optical conversion
OSNR	Optical Signal to Noise Ratio
OTM	Optical Transmission Module
OTN	Optical Transport Network
OXC	Optical Cross Connects
QoS	Quality of Service
RAs	Raman Amplifiers
ROADM	Reconfigurable Optical Add/Drop Multiplexer
SDH	Synchronous Digital Hierarchy
SOA	Semiconductor Optical Amplifier
SONET	Synchronous Optical Transport Network
SRS	Stimulated Raman Scattering
STM	Synchronous Transport Module
WDM	Wavelength Division Multiplexing
WSS	Wavelength Selective Switch

CHAPTER 1: Introduction

1.1 Background

Over the past two decades, global traffic is increasing at about 20- 40% per year and is doubling approximately every 2 years [1]. Also, the number of Internet users is growing at a rate of about 20% per year [2]. Thus, data traffic volume and the number of Internet user increase have led to further deployment of telecommunication network infrastructures. Due to this, power consumption of the network is continuously increasing. In addition, new network technologies and structures need to be developed and implemented to satisfy the traffic demand and to support emerging services. For example, electrical communication systems using electrical cables have been replaced by optical fiber cables, which enhance the bandwidth of the channels to reach Tbit/s. The need for this high capacity network with faster communication link has resulted in an increasing demand for faster computers, which in turn increase power consumption. Besides this, power demanding equipment, such as servers, amplifiers, routers, filters and storage devices are used in current data communication networks, which boost the power consumption of the communication network.

Aggregate traffic which is collected from millions of customers in the different periphery is carried by the backbone network to span thousands of kilometers. Thus, the backbone network requires a high capacity network with faster communication link. The contribution of the backbone network to the total network power consumption is increasing significantly in line with the traffic growth [3]. In 2008 the telecommunication sector accounts for approximately 4% of the global electricity consumption and the backbone network equipment have their share with the largest amount being consumed by broadband access network [4]. Figure 1.1 shows a forecasted worldwide energy consumption growth of telecommunication networks [5].

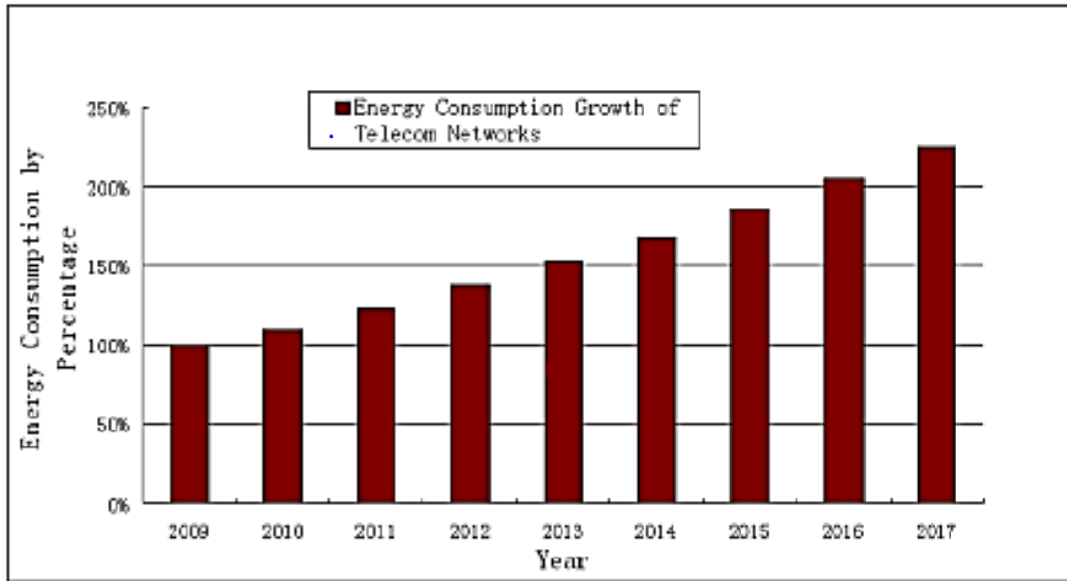

Figure 1.1: Energy consumption trend of telecommunication networks [5, 6]

This growing trend has resulted in an energy efficiency issue to become a high-priority objective [7]. Two main research directions are being explored to solve these energy consumption increment problems: usage of renewable energy sources (related with environmental impact reduction) and investigating energy consumption minimization approaches (related with economic impact reduction).

Many researchers started to investigate energy consumption minimization approaches. Energy consumption reduction techniques were initially developed for already designed networks. Since the traditional networks are designed considering the worst-case traffic scenario and in a redundant manner for service reliability, there was enough room to save energy in the operation phase. But as energy consumption of telecommunication networks further increased, additional energy-saving techniques are also devised such as energy-aware network design [1, 8].

In this regard, International Telecommunication Union (ITU-T) in Y.3001 recommended energy consumption minimization of networks to use device-level, equipment-level and network-level technologies to improve energy efficiency and to satisfy customers' demands for future networks.

It is recommended that all these approaches cooperate in achieving a better solution for network energy savings [9].

Previously, different stakeholders addressed energy consumption increment problems in telecommunication networks. According to [1], operators, equipment vendors and researchers employed valuable efforts dedicated to reducing unnecessary energy wastage using energy consumption minimization approaches such as designing of low power components with the same level of performance, redesigning network architecture and considering network component power consumption as optimization objective during network design phase. Based on this, different energy-saving techniques for networked equipment and a mechanism to design energy-aware network and networking equipment have been developed to reduce unnecessary energy waste in network infrastructures [7].

The energy consumption contribution of the different network segments was assessed in the past. Until recent years' access networks consume significantly higher energy values than those found at the operator premises [1, 4]. According to [4], in the fixed-line networks user segment consumes more than 70% of the overall power consumption and the rest 30% are due to the operator premises equipment. But highest energy consumption growth rates were forecasted in the data centers and Internet Protocol (IP) backbone networks [1, 8]. According to [8], in 2009 Deutsche Telekom predicted that by the year 2017, the power consumption of the network core would be equal to that of the network access and for the next decade, a 12-fold increase in the power consumption of the network core is expected due to traffic growth. As a result, power consumption in backbone networks has received increased attention.

Different specific studies have been conducted on (IP over Wavelength Division Multiplexing (WDM)) networks to improve the energy efficiency of a network using energy-saving techniques. Some of the techniques are suited for network operation phases such as sleep mode operation, dynamic operation, energy-aware resilience and energy-aware routing; and some others are employed in network design phases such as traffic grooming, network architecture modification, and physical topology optimization.

Previously sleep mode operation was assessed considering ethio telecom North-East and Addis Ababa optical backbone network topologies. Ethio telecom North-East backbone network

topology has lower network connectivity than Addis Ababa backbone network topology and there is no optical amplifier in Addis Ababa network. The authors considered QoS parameters such as link utilization and path loss in addition to power consumption minimization in applying sleep mode operation on the network using an optimization platform and simulation environment. The authors described that in Addis Ababa backbone network 51% energy can be saved with link utilization of 70% and in North-East circle optical backbone network 44% energy can be saved with link utilization of 50%.

In this thesis, a power consumption minimization method based on the design approach, which focuses on line amplifier placement is investigated, evaluated and proposed considering ethio telecom North circle optical backbone network topology.

1.2 Literature Review

In this section, a review of some related papers will be discussed in detail. The following papers mainly focus on the energy-aware design of core and optical backbone network (IP over WDM network) for minimization of power consumption.

Dong et al. optimized physical topology of IP over WDM networks using Mixed Integer Linear Programming (MILP) model under different scenarios such as optical bypass and non-bypass, nodal degree constraints and traffic symmetry in [3]. In this work, the authors optimized the deployment of physical links that interconnect nodes such as number of router ports, number of transponders and number of fibers based on the traffic demand. The topology of the National Science Foundation Network (NSFNET) network with 14 nodes and 21 bidirectional links is considered to evaluate the performance of the model in an optimization platform. The optimized topologies under the non-bypass approach have resulted in average power savings of 11% and 10% with Node degree 1 and 2 respectively as compared to the original network topology. But power consumption in the optical bypass approach is almost insignificant. In this work, little attention is given to optical line amplifiers placement from physical and economic restriction and energy saving view point.

Dong et al. also optimized the physical topology of IP over WDM core networks to minimize embodied and operational power consumption in [11]. The authors used the MILP model to

optimize the physical topology of core networks by optimizing the deployment of physical links. The network topology in [3] is used to study the performance of the optimization in an optimization platform. The results showed that 47% power saving can be achieved using this optimization when the embodied energy of the component is considered.

Jorge López evaluates the possible energy and spectral benefits achieved by the deployment of additional optical line amplifiers in a Mixed Line Rate (MLR) WDM network using a heuristic approach [12]. The results in this work showed that, using additional amplifier in MLR network can enhanced the energy efficiency per GHz of the network up to 74% and enlarges its overall capacity by 27Tbps at high traffic loads by inviting high rate transponders into the system. This research is more on the number of amplifiers added in to the network to improve spectral and energy efficiency at high rate transmissions rather than the location where an amplifier is placed.

Generally, physical topology optimizations by Dong et al. above mainly focused on defining which is the minimum set of routers and links that have to be used to support a given traffic demand with minimum power consumption. Specifically, optimizing the number of router ports in the upper layer, optimizing the number of transponders and number of fibers based on traffic demand to minimize the power consumption. But little attention is given to optical line amplifier placement (location). In these works, optical line amplifiers are placed at 80km spacing. In addition, work in [12] above focused on the number of additional amplifiers required in each link to improve spectral efficiency rather than the actual location where the amplifier is placed.

In this thesis, the focus is on optimizing the placement of optical line amplifiers in WDM network for energy saving.

1.3 Motivation

Many studies in the literature made the simplifying assumption that, if Erbium-Doped Fiber Amplifiers (EDFAs) are placed at 70/80km spacing in a link, it will be optimum from performance and cost perspective for transmission rate up to 100Gbps [6]. But this may not be always practical due to physical and economic restrictions such as unavailability of supply power, shelter, and other physical security requirements. Furthermore, extra unnecessary amplifiers may be added in the link and extra energy may be waste in such configuration

(placement); because EDFAs can compensate losses accumulated over 80 – 100km or even more than 100kms [13, 14, 15]; so, the remaining 20 – 30km can help to minimize the number of amplifier sites for longer links.

In practice, amplifiers are placed based on some design guidelines, in locations having supply power and shelter considering received power level constraint with the expense of additional power consumption. The metro Dense Wavelength Division Multiplexing (metro DWDM) design guideline based on Cisco ONS 15454 device states that “Work from the reference node in one direction, place the first EDFA at the position where there is a loss of 19dB, or the measured power level is -19dBm per channel. If the -19dB point is at a mid-span position, check the power level at the input of the next node. If this power level is above -22dBm, the EDFA can be positioned at the next node. Otherwise, it should be placed at the preceding node with an attenuator at the input to avoid exceeding the amplifier maximum input power. The attenuator should bring the EDFA input power to -6dBm” [16]. But from strict energy conservation perspective only measured (input) power level constraint may not be sufficient, because the required input power level can be achieved using an attenuator card to fill shorter reach as shown above or using a high power-consuming card to extend the reach with the expense additional power consumption and cost.

Researchers are made efforts dedicated to reduce unnecessary energy waste in backbone networks. Among those efforts, Internet Protocol (IP) over Wavelength Division Multiplexing (WDM) network physical topology optimization for power consumption minimization can be mentioned [3,11]. But this optimization mainly focuses on defining the minimum set of router ports, transponders and number of fiber that can support a given traffic with router port power consumption of 1000w, transponder with a power consumption of 100w and amplifier cards with a power consumption of 8w to achieve better energy saving. This makes power consumption contribution of amplifier cards to be less than 3% [17,18]; which is worthless for potential energy saving area identification. But link power consumption by way of optical amplifier (power consumption of amplifier card and management shelf) is 10% of the total segment board configuration power consumption [2]. This 10% power consumption contribution leads to the assumption that power consumption minimization techniques can be applied in optically amplified WDM link to save energy.

1.4 Problem Statement

Researchers are made efforts dedicated to reduce unnecessary energy waste in backbone networks using physical topology optimizations for highly connected networks, but those formulations are not feasible for low connected networks like ethio telecom.

In addition, current ethio telecom line amplifier placement is done at span length ranging from 25 to 120km considering these physical and economic restrictions [19]; due to this, ethio telecom is subjected to high power consumption in line amplifiers. To avoid such a problem, which has resulted in a high power consuming configuration of links, because of the influence of physical and economic restriction, where should each optical line amplifier be placed is one research question.

Furthermore, to the best of our knowledge power consumption minimization using optimal line amplifier placement taking physical and economic restrictions in to account was not done before.

1.5 Objectives

1.5.1 General objective

The main objective of the thesis is to minimize optical backbone network power consumption by using optimal line amplifier placement considering span length constraint in addition to input (measured) power level constraint at each amplification point.

1.5.2 Specific objectives

To achieve the general objective, the specific objectives of this thesis are:

- To analyze the power consumption of the optical backbone network. The analysis includes the total segment, node, component and link power consumption considering the equipment deployed at ethio telecom North circle optical backbone network.
- To identify power saving area and power saving approach.
- To evaluate the power saving performance of the identified approach
- To propose amplifier site deployment approach for energy (power) saving.

1.6 Methodology

To achieve the above-stated objectives, this thesis follows the methodologies listed below.

- Data collection from relevant documents and literature.
- Data analysis. This includes power consumption analysis and preparation of data sets for the optimization problem formulation such as fiber length of possible pre-defined points and others.
- Understand different energy-saving approaches & optimization tools.
- Optimization problem formulation taking energy (power) as an objective function.
- Optimize ethio telecom North circle optical backbone network topology using the new formulation to evaluate the performance of this approach for energy saving. Optimum placement location assignment of the optimization problem is done using MATLAB. Based on this result, the amplifier site's power consumption is computed. Finally, a comparison is done with that of the theoretical approach and the existing network configuration power consumption to draw a conclusion.

1.7 Scope

The scope of this thesis work is on energy efficient design of optical backbone network topology via optimization of line amplifier placement. This approach minimizes network power consumption by minimizing the number of amplifier sites while still maintaining network performance at the desired level using different constraints for North circle optical backbone network topology. In this thesis, constraints such as span length, input power level to the amplifiers and path loss/attenuation are used.

1.8 Contribution of the Thesis

In this thesis, a MILP problem is formulated for power minimized and physical layer parameter-aware network design to minimize the energy wastage in the optical backbone network without affecting signal quality. This thesis introduces additional optional pre-defined locations with supply power, shelter and physical security for line amplifier placement to minimize power consumption. This helps a company by saving energy and reduces capital and operational cost.

1.9 Organization of the Thesis

The rest of the thesis work is organized as follows. Chapter 2 of the thesis gives an overview of optical transport system (WDM system), physical impairments in the optical transport system, detail description of optical amplifiers and exact position of optical components in the optical transport system. Chapter 3 deals with the power consumption of optical backbone network, equipment power consumption in optical backbone infrastructure, approaches employed to save power in the backbone network. Chapter 4 covers methodology that is followed such as data collection, data analysis, area and approach identification and problem formulations based on literature review findings and available data. Chapter 5 gives the result of the problem by segmenting into two sections: section one gives the result for the amplifier placement problem and sections two gives the result of power consumption for different amplifier site placement scenarios. In the discussion section power consumption contribution and power-saving performance is evaluated for the placement optimized, the theoretical approach and the existing configuration. Finally, Chapter 6 contains a conclusion and recommendation of some future works.

CHAPTER 2: Overview of Optical Transport System

2.1 Introduction

Electrical communication systems using wire pairs and coaxial cables and microwave communication systems using electromagnetic carrier waves were developed before 1966. But due to bandwidth limitation of the electrical communication system by frequency-dependent cable losses and bit rate limitation of a microwave communication system by carrier wave frequencies which affect bit-rate–distance products that reduce repeater spacing, a new communication system which has higher bandwidth and better bit-rate–distance product was needed. It was suggested in 1966 that optical fibers might be the best choice, but due to high losses of optical fiber (1000 dB/km) at that time, it was not applicable for the communication system. A breakthrough occurred in 1970 when fiber losses reduced below 20dB/km in the wavelength region near 1 μm . At about the same time, semiconductor lasers, operating continuously at room temperature, were demonstrated. The simultaneous availability of compact optical sources and a low-loss optical fibers led to a worldwide effort for developing fiber-optic communication systems using WDM technique [13].

2.2 WDM System

Optical (WDM) networks provide a common infrastructure over which a variety of services can be delivered. These networks are also increasingly becoming capable of delivering bandwidth in a flexible manner where and when needed [15]. Optical transmission systems consist of nodes and links. Nodes are points in the network that source/terminate and switch traffic such as Reconfigurable Optical Add/Drop Multiplexer/Optical Transmission Modules (ROADM/OTM) sites and links interconnect these nodes. In an optical transmission system, amplifier sites are sites that solely perform amplification.

In an optical transmission system, the high capacity is achieved using the WDM technology, where multiple wavelength channels are multiplexed into a single fiber. The WDM system is classified as DWDM (Dense wavelength division multiplexing) and CWDM (Coarse Wavelength Division Multiplexing). The two categories differ in the channel spacing they

employ, which in turn determines the number of wavelength channels available. CWDM supports up to 16 channels [21]. Whereas, DWDM supports a maximum number of 140 wavelength channels on a fiber theoretically [22].

WDM networks have two generations: In the first generation, optics were essentially used for transmission and simply to provide capacity. It was used as a replacement for copper cable since optical fiber provides a higher capacity than copper cable [15]. All switching and other intelligent network functions were handled by electronics. As a result, the energy consumption of WDM networks was not small during the first generation. Second-generation optical networks can provide more functions than just point-to-point transmission by incorporating some of the switching, routing and other intelligent functions that were performed by electronics into the optical part of the network. This type of network is called a wavelength routing network. Such networks are the Optical Transport Network (OTN) [15]. OTN is regarded as the set of facilities using optical fiber interconnections to carry data between network elements that switch or route the data from different customers into the network and it provides transport, multiplexing, routing, supervision and survivability for client signals. OTN is specified in ITU-T Recommendation G.873.1 [21]. Compared with the traditional SONET/SDH, OTN network provides benefits such as more efficient multiplexing and switching of high-bandwidth services, enhanced monitoring capabilities, and stronger forward error correction (FEC) [20].

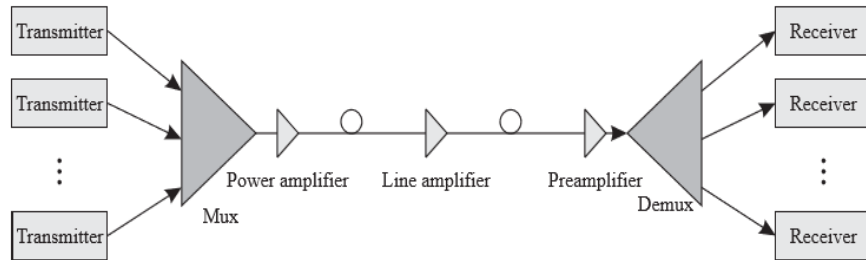

Figure 2.1: Components of the WDM system [15]

Nowadays, WDM systems are widely deployed in long-haul, metro and undersea networks. Particularly DWDM systems are used by telecom operators on a large scale to build their backbone infrastructure. DWDM is a technique, where many wavelength channels, each employing a single wavelength are multiplexed onto a single-fiber transmission medium to

provide high capacity for present and future Internet applications. Backbone networks span regional, nationwide, continental and international distance to interconnect large cities. Figure 2.2 shows an optical backbone network consisting of different components at the optical layer to interconnect core network devices in the IP layer.

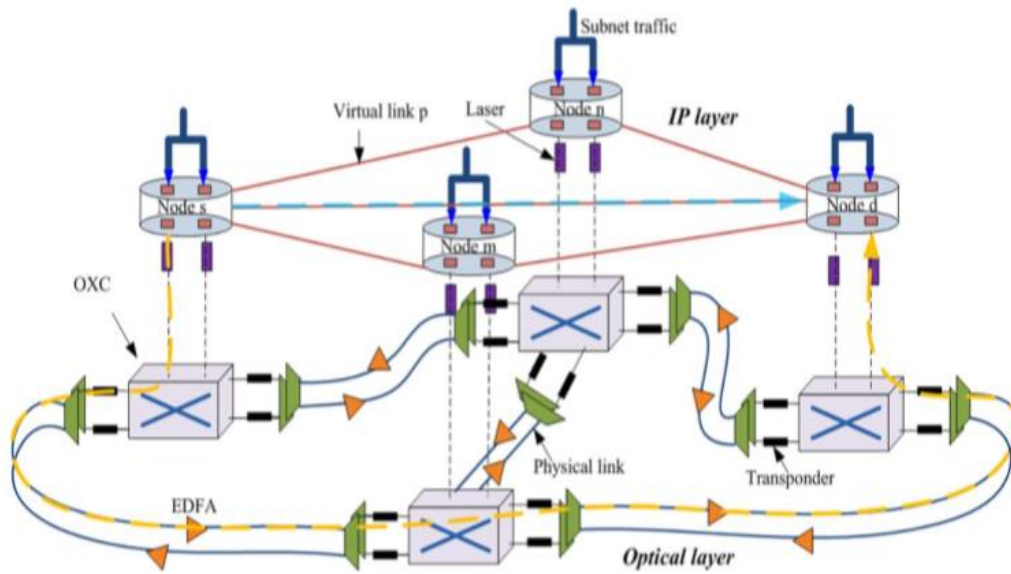

Figure 2.2: IP over WDM system [3]

Optical backbone networks consist of optical transponders, optical line amplifiers, optical cross-connects, and optical fibers each with different functionality [5]. For example, each optical signal is generated by an optical transmitter and received by a receiver. Both the transmitter and the receiver are in a transponder. Pre & booster amplifier together with multiplexer/ de-multiplexer are in WDM terminals. Optical terminals are equipped with transponders. Multiplexers are units that combine multiple light signals exiting the multiple transponders which are tuned to the wavelength as per the system requirement. Multiplexers are mainly used to increase the amount of data over the network. De-multiplexers are used to separate wavelengths or convert serial data signal at the input to a parallel data at its output to send to its receiver. Dynamic optical capabilities in WDM can be achieved with the introduction of optical cross-connect (OXC) nodes, which can switch the wavelengths completely in the optical domain. Long-distance transmission can be achieved by using optical amplifiers. Especially, EDFAs are a key enabler of a cost-effective WDM system [20].

An important property of an optical transmission system is an optical reach, which is the maximum distance an optical signal can be transmitted before it degrades to a level that requires the signal to be regenerated. Nowadays, the optical reach is extended from the traditional 500km to 2000km to 4000km due to the capability of all-optical networks. But increasing the reach would require more expensive components; such as higher-power amplifier pumps, more precise lasers, and filters and better forward error correcting chips [20, 23].

The optical transmission system has several advantages over copper cable and wireless transmission systems such as huge bandwidth, low transmission loss, signal security, immunity to interference and crosstalk, potentially low cost due to efficient utilization of common resources and relative efficiency concerning power consumption. Although the optical transmission system has many advantages, it has also impairments due to light properties, fiber cable material properties, interaction of light with optical fiber material and construction or deployment of optical fibers [20, 21].

2.3 Physical Impairments

Physical impairments are factors that affect the performance of optical fiber transmission media such as fiber attenuation/ transmission loss, dispersion and nonlinear effects [13]. Losses due to nonlinear effects are not considered in this thesis.

Attenuation is the gradual degradation of optical signal level (intensity) in optical fiber as it travels from the transmitter to the receiver. A number of mechanisms are responsible for the signal attenuation within optical fibers. These mechanisms are influenced by the material composition, the preparation and purification technique, and the waveguide structure. They may be categorized within several major areas which include material absorption, material scattering (linear and nonlinear scattering), curve and micro bending losses, mode coupling radiation losses and losses due to leaky modes. There are also losses at connectors and splices. The overall fiber attenuation is of greatest interest to system designer. All the above mentioned factors contribute to overall losses, but the two most important among them are material absorption and Rayleigh scattering [13, 21]:

- Material absorption losses: Material absorption is a loss mechanism related to the material composition and the fabrication process for the fiber, which results in the dissipation of some of the transmitted optical power as heat in the waveguide. The absorption of the light may be intrinsic (caused by the interaction with one or more of the major components of the glass) or extrinsic (caused by impurities within the glass) [21].
- Rayleigh scattering is a fundamental loss mechanism arising from local microscopic fluctuations in density. Silica molecules move randomly in the molten state and freeze in place during fiber fabrication. Density fluctuations lead to random fluctuations of the refractive index on a scale smaller than the optical wavelength. Light scattering in such a medium is known as Rayleigh scattering. This scattering due to the density fluctuations produces attenuation proportional to $1/\lambda^4$. Where λ is the wavelength of light [13].

In optical communication, power or signal levels are measured in Decibel (dB) [15]. The dB units are used to express loss, gain and reference power values. Relative values of power like gain and loss are expressed in dB and reference power value is expressed in dBm. Signal attenuation within optical fibers is usually expressed in a logarithmic unit of decibel. Attenuation in optical fiber is a function of fiber span. Equation (1) will give fiber attenuation loss in a link.

$$\alpha * L = 10 \log_{10} p_i / p_o \quad (1)$$

Where α is the signal attenuation per unit length in dB, L is the fiber span in kilo meters and p_i and p_o is the input power into the fiber and output power from the fiber respectively [21]. In a typical optical communication system, a signal can experience a loss of about 20 – 30dB before it needs to be amplified [15].

Dispersion is spreading of light pulses when propagation through a fiber due to numerical aperture, core diameter, refractive index profile and wavelength in the fiber. Dispersion of the transmitted optical signal causes distortion for both digital and analog transmission along optical fibers and it causes Inter Symbol Interference (ISI) in a transmission system which limits the bandwidth of a fiber. Dispersion accumulates as a linear function of the propagation distance [6, 21].

The three major dispersions in optical fiber are:

- Chromatic dispersion: the propagation speed of light within a fiber depends on the optical frequency. This causes the optical signal pulses, which have a finite spectral width, to be distorted as they propagate along a fiber. This phenomenon is known as chromatic dispersion. Chromatic dispersion is the phenomenon by which different spectral components of a pulse travel through the fiber at different velocities and arrive at different times at the receiver. It occurs due to the material and waveguide dispersion phenomena [6, 20].
- Modal dispersion results from the propagation delay differences between modes within a multimode fiber. As the different modes which constitute a pulse in a multimode fiber travel along the channel at different group velocities, the pulse width at the output is dependent upon the transmission times of the slowest and fastest modes [21].
- Polarization Mode dispersion (PMD) is a source of pulse broadening which results from fiber birefringence and it can become a limiting factor for optical fiber communications at high transmission rates. It is a random effect due to both intrinsic (caused by noncircular fiber core geometry and residual stresses in the glass material near the core region) and extrinsic (caused by stress from mechanical loading, bending or twisting of the fiber) factors which in actual manufactured fibers result in group velocity variation with polarization state [21].

Generally, a signal is attenuated due to corruption by random signals and noise or distorted by mechanisms imposed within the medium itself. Therefore, in any communication system, there is a maximum allowable distance between the transmitter and the receiver beyond which the system cannot give its proper function. For long-haul applications, these factors require the installation of repeaters or line amplifiers and dispersion compensation modules at regular intervals in a link to overcome signal attenuation and distortion respectively [21].

2.4 Optical Amplifiers

In an optical network, the strength of optical signal power from transmitters attenuates gradually as it propagates through optical fibers [15]. To overcome this attenuation, amplifiers are used in the fiber optic transmission system. Optical amplifiers boost the amplitude of an optical signal or add gain before it becomes too weak to be detected by receivers. Most optical amplifiers amplify

incident light through stimulated emission, the same mechanism that is used by lasers [13]. Before the advent of optical amplifiers, amplification was done using optoelectronic regenerators to regenerate the signals. Regenerators convert an optical signal to an electrical signal for processing and then convert it back for transmission. But at each regenerating point, every wavelength needs to have its regenerator due to its unique wavelength and power range. On the other hand, an optical amplifiers can restore the strength of an optical signal without any optical-electrical-optical conversion. Furthermore, it can amplify several WDM signals simultaneously. Hence, optical amplifiers have become a very important component of WDM networks due to no need for high-speed electronics, transparent to bit rate and format and simultaneous amplification of multiple wavelengths [13, 25].

In the design of a fiber-optic communication system, optical amplifiers can serve several purposes. The most important application for long-haul systems consists of using amplifiers as in-line amplifiers which replace electronic regenerators.

Inline amplifiers are in-fiber devices that are located at strategic points along a long DWDM transmission link to compensate fiber attenuation losses. Optical line amplifiers are designed for optical amplification between two network nodes on the main optical link. In-line amplifiers are placed at each 80 – 100km to ensure that the optical signal level remains above the noise level [26]. Inline amplifiers have characteristics like medium to low input power, high output power, high optical gain, and a low noise figure [26].

Optical amplifiers can also be used to increase the transmitter power by placing an amplifier just after the transmitter [13, 15]. Such an amplifier is called a power amplifier or power booster. Power amplifier can increase transmission distance by 100 km or more depending on the amplifier gain and fiber losses. Transmission distance can also be increased by putting an amplifier just before the receiver to boost the received power. Such amplifiers are called optical pre amplifier and is commonly used to improve receiver sensitivity [13, 15]. The pre & booster amplifiers together with the multiplexer/ de-multiplexer are often referred to as WDM terminals, which provide the interface between fibers and OXCs [5].

The desired properties of the three cases are different. Booster amplifiers require high gain; pre-amplifiers need a low noise figure and inline amplifiers require both. Optical amplifiers are also

engaged at different other points in a network (for example, in an optical switching node to compensate for losses in the switch fabric [14, 15]. Figure 2.3 shows the different functions of optical amplifiers such as booster, in line and pre-amplifiers in a link.

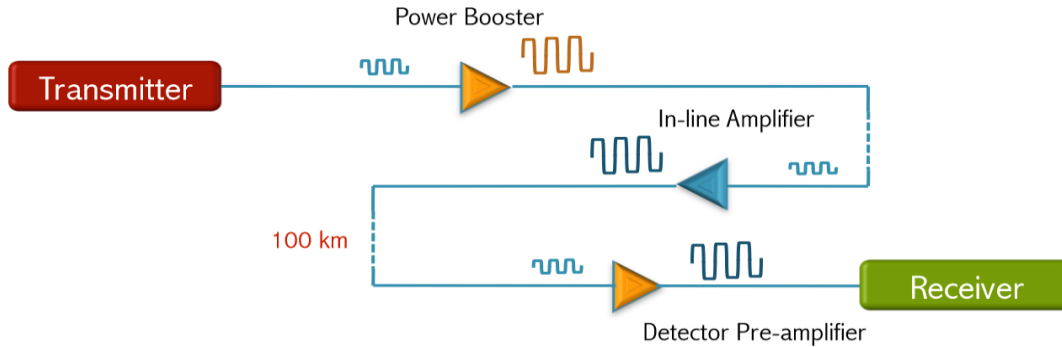

Figure 2.3: Optical amplifier functions [27]

The main optical amplifiers in use currently are Erbium-Doped Fiber Amplifiers (EDFAs), Raman Amplifiers (RAs), and Semiconductor Optical Amplifiers (SOAs). EDFAs and RAs are fiber amplifiers. SOAs are semiconductor optical amplifiers, which use semiconductor laser diode with anti-reflection coating on surfaces.

2.4.1 Semiconductor Optical Amplifiers

Semiconductor optical amplifiers (SOAs) are amplifiers which use a semiconductor to provide the gain medium. They operate similarly to standard semiconductor lasers and are packaged in small semiconductor "butterfly" packages. Unlike other optical amplifiers, SOAs have pumped electronically i.e. no need for separate pump laser. Semiconductor Optical Amplifiers (SOA) was developed in the 1980s but they are not used in long-distance transmission because of several negative features such as SOAs introduce severe crosstalk when they are used in WDM systems due to their higher noise figures of 7 to 11dB. Although SOAs can be used to amplify several channels simultaneously, they suffer from several drawbacks which make their use as in-line amplifiers impractical. A few among them are polarization sensitivity, inter-channel crosstalk, and large coupling losses. SOAs are not as good as EDFAs for use as amplifiers. However, they are used for other applications in switches and wavelength converter devices [10, 13, 15, 21].

2.4.2 Optical Fiber Amplifiers

Fiber amplifiers have become an essential part of almost all fiber-optic communication systems installed after 1995 because of their excellent amplification features such as low insertion loss, high gain, large bandwidth, low noise, and low crosstalk. In this regard, EDFA is the predominant one [13].

There are two main well-known types of amplification for optical transport networks using fiber amplifiers: EDFA and distributed RA. EDFA is the most widely deployed optical amplifier. RA can be considered to extend the transmission of high-speed optical systems by taking advantage of its lower effective Noise Figure (NF) [6]. Since the focus of this thesis is on EDFA detail description of this amplifier type and its advantage over RA is given in the following section.

A. Erbium-Doped Fiber Amplifier (EDFA)

The EDFA belongs to a family of rare-earth-doped fiber amplifiers. It is composed of an optical fiber with a length of a few meters doped with the rare-earth element erbium. Erbium has an important property, which produces amplification in a wide band of about 35 nm within the 1550 nm low-attenuation window in fibers. Other possible dopants, including praseodymium, neodymium, ytterbium, and thulium can be used to realize fiber amplifiers [6, 13].

The amplification process of EDFA is initiated by stimulated emission of excited erbium ions from higher energy level to lower energy level. The EDFA is an optically pumped device, which is usually pumped by semiconductor lasers at 980nm or 1480nm wavelength for population inversion and provides amplification of optical signals by effecting stimulated emission of photons by Erbium ions implanted in the core of the optical fiber. The stimulated emission takes place in the wavelength window of 1530 to 1565 nm. If a data signal with the corresponding wavelength is fed into the fiber, the newly generated photons by stimulated emission are responsible for amplification of signal as it travels along the fiber. There are also incident photons that could have originated as spontaneous emission which is called amplified spontaneous emission (ASE), which represents the major source of noise in amplified fiber transmission systems [14, 15, 22].

For a given fiber structure and doping and given pump power, there is an optimal fiber length that maximizes gain. For lengths smaller than the optimum, the pump power is not maximally utilized and for larger lengths, pump power is exhausted somewhere along the fiber and attenuation takes over. The gain of an EDFA is approximately independent of the signal power as long as the pump power is made high enough so that the pumping rate is much larger than the stimulated emission rate. This is called the unsaturated gain or small-signal regime. The small-signal gain under these conditions is an increasing function of pump power [14].

Gain saturation is a property that all amplifiers eventually exhibit as the signal power increases. It is an important consideration in designing amplified systems of the EDFA. Depending on the pump power and the amplifier design, the output power of the amplifier is limited. As a result, when the input signal power is increased, the amplifier gain drops. For low input powers, the amplifier gain is at its unsaturated value. Output saturation power is usually on the order of 10 to 100mW (10 to 20dBm). This saturated output power of the amplifier is defined at the point where the amplifier gain is reduced by 3dB and this point is referred to as gain saturation. There is no fundamental problem in operating an EDFA in saturation and power amplifiers usually do operate in this region. But it should be kept in mind that the saturated gain will be less than the unsaturated gain. The maximum unsaturated gain and saturation power of typical EDFA is 30dB and 10dBm respectively, where G_0 is the unsaturated gain [14, 15, 21].

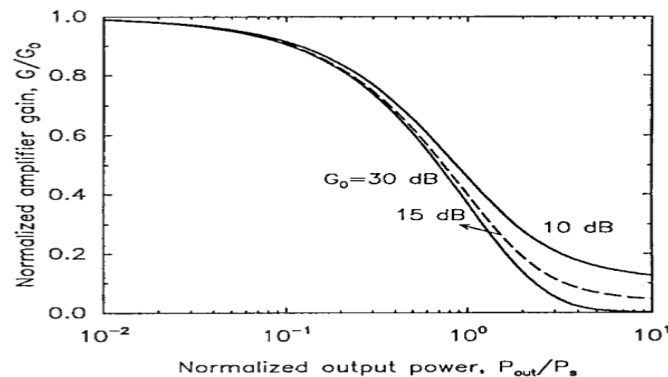

Figure 2.4: Saturated amplifier gain G as a function of the output power [13]

The gain of EDFA depends on the pump power as well as on the pump wavelength. Gain is the ratio of the output signal power to the input signal power of an amplifier. Ideally in a typical attenuation compensated optical fiber link, the gain of amplifier will be set equal to the loss of

fiber span immediately before the amplifier. In a cascaded system, the amplifier gain must be at least large enough to compensate for the loss between amplifier stages; otherwise, the signal will be degraded rapidly with the number of stages [15]

The noise figure of an amplifier is a parameter that is used to quantify optical amplifier noise due to Amplified Spontaneous Emission (ASE). A low noise figure indicates less signal degradation [15]. Numerous factors affect the NF of a link. For example, the type of amplification is very important, where Raman amplification generally produces a lower NF than EDFAs. Large fiber attenuation and large splicing losses or longer span distances and the fiber type can also contribute to a higher NF [15].

Deployment of WDM systems is possibly realized by the advent of major element EDFA. The use of WDM and EDFAs dramatically reduced the cost of the long-haul transmission systems and increased their capacity [15]. Although the EDFA played a vital role in extending the reach of optical transmission systems it still had some drawbacks, including the operation to a limited band of the optical spectrum most commonly in C and L bands and a non-flat gain profile. Since amplification is realized using population inversion, the population is not distributed uniformly within the energy band. As a result, the gain is not flat. Gain flattening is an important consideration in EDFAs. Several solutions are in use currently for this problem. One solution is to modify the design of the amplifier itself by using different materials such a fluoride glass. The other approaches use gain equalization via controllable attenuators or inverse filtering [14].

B. Raman Amplifiers

Raman amplifier uses stimulated Raman scattering (SRS) for amplification. When SRS is used for amplification, pump power is introduced into a fiber carrying an optical signal, with the pump operating at a frequency higher than the signal frequency. In this case, the incident pump photon gives up its energy to create another photon of reduced energy at a lower frequency. The RA can be configured either as a distributed or discrete amplifier. A typical distributed RA consists of a long transmission fiber into which a counter-propagating (backward) Raman pump is injected. In a discrete RA, the amplifier consists of a coil of fiber together with pumps and auxiliary equipment for monitoring, control and possibly other purposes such as dispersion compensation, gain flattening or adding and dropping channels [14,15].

The major differences between RAs and EDFAs lie in the fact that EDFAs require the deployment of special Erbium-Doped Fiber (EDF). On the other hand, Raman amplification is an intrinsic effect of all fibers. RA operates in ordinary silica fibers, requiring no special materials or dopants [6]. The other advantage of Raman amplifiers over EDFAs is RAs have lower effective Noise Figure (NF) as compared to EDFAs which allows for much lower Optical Signal to Noise Ratio (OSNR) degradation. Typical NF of a Raman amplifier is about 4dB, which is better than the NF of an EDFA [13]. The noise figure of EDFAs is expected to be larger than the ideal value of 3dB [13]. Practical EDFAs typical noise figure value is in the 4–7dB range [15]. Another advantage is the possibility to amplify more spectrum bands. Usually, EDFAs amplify the signal in C and L bands ranging from 1530 to 1625nm [13, 15]. The most popular use of Raman amplifiers is to complement EDFAs by providing an additional gain in a distributed manner in ultra-long-haul systems [15].

RA has many technical and economical disadvantages when compared with EDFA.

- RA has a problem associated with the need for working with very high-power levels, which may raise penalties due to non-linear effects [6]. Besides,
- Raman amplifier has a higher cost than EDFA.
- RA requires long fiber, which tends to increase the multipath effects.
- RA presents lower gain than EDFA; Raman amplifier can provide 20dB gain at a pump power of about 1W [13], but EDFA has gain ranging from 15 – 30dB.
- RA is less efficient than EDFA in converting pump power to output signal power. However, its efficiency improves, exceeding that of the EDFA, at the large aggregate signal powers that occur in long-haul WDM systems with high channel counts.
- RA has a fast response to pump fluctuations, which can lead to the coupling of pump noise into the amplified signals. Even though, these effects can be mitigated by using a counter-propagating pump [13, 14].

In addition, in deploying a RA as a discrete amplifier, there are practical issues due to the high pump power employed. Connectors should be minimized to reduce reflections and attenuation, and when connectors are required, they must be designed to overcome the high pump power.

Besides, Automatic Laser Shutdown (ALS) systems must be employed to protect people at very high-power level operations [14].

Generally, EDFA has widespread use in the WDM system due to its best performance and lower cost as compared to SOA and RA.

The basic form of EDFA consists of a length of EDF, a pump laser, and a WDM system for combining the signal and pump wavelength so that they can propagate simultaneously through the EDF [26]. EDFA modules used in the field typically include other components, such as optical isolators to eliminate reflected power, and various devices for signal power monitoring, stabilization, and control [14]. Figure 2.5 below shows an EDFA card with a length of the fiber and a pump laser.

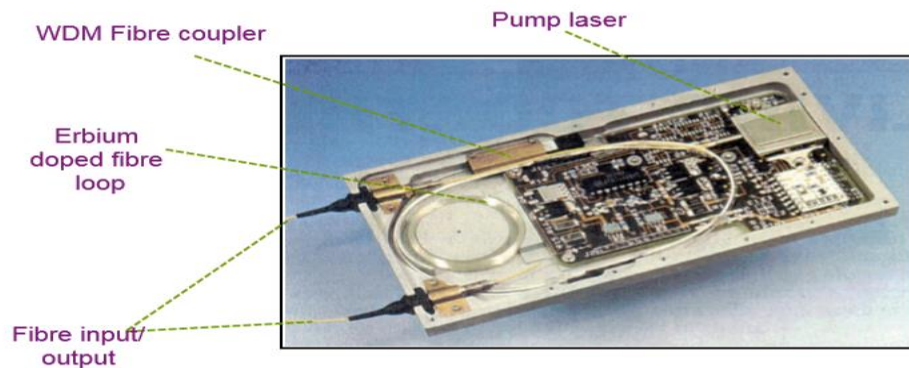

Figure 2.5: EDFA cards [27]

2.5 Component Placement in a Link

Major requirements in optical network link design are proper component placement and then making the link feasible for power value at each point of the link. Placement of DWDM components in a network requires analysis of the distance between two nodes (ROADM/OTM) sites, type of data rate, technical specifications of the component and their gain and insertion losses. The technical specification of the components includes operating wavelength band and fiber specifications such as the attenuation factor and the chromatic dispersion coefficient measured per kilometer of fiber length. WDM components are placed at a different point in the

network based on their function intended to perform. For example, multiplexer/de-multiplexer units are always placed (positioned) at the transmitter and the receiver ends to multiplex wavelengths provided by the client node (transponder) and de-multiplex from the network side respectively [22].

ROADM is a form of an optical add-drop multiplexer or one type of optical switch that allows an individual or multiple wavelengths channels carrying data information to be added or dropped from incoming fiber links [22]. Booster amplifiers are placed before every ROADM site to boost the signal power before sending it on the fiber link. Pre-amplifiers are placed before every ROADM site to strengthen the signal that has traversed through a long link and then is feed at the receiving node (to improve receiver sensitivity).

Optical line amplifiers are placed at periodic intervals in the fiber link, typically 80 –120km [15]. This spacing depends on the fiber type (attenuation coefficient) used (i.e., the above value corresponds to 0.2dB/km attenuation coefficient). For attenuation coefficient greater than 0.2dB/km the maximum distance will be reduced below 120km. This spacing is referred to as span length which is the portion of a link that runs between two amplifier sites or between a node and an amplifier site [20]. For practical use, line amplifiers should be placed strategically throughout the network in a way that assurances that all the signals are amplified effectively while minimizing the total number amplifiers being used. When placing optical amplifiers, care should be taken such that power should not go beyond the boundary conditions for the safety of the system and better performance [22].

Dispersion Compensation Module (DCM) is another important component in the link, which has to be placed at ROADM or EDFA sites to compensate dispersion of the signal that travels over long distances through the fiber. DCMs are preferably placed before the EDFA site for compensation of DCM insertion loss by the EDFA next to it [22]. In this thesis, it is assumed that DCM is placed at the OADM site to compensate dispersion.

Link optimization comprises optimal placement of optical amplifiers (OAs) and DCMs for each fiber link to ensure enough minimization of all-optical impairments. A fiber link starts and ends at a central office containing a ROADM site with an intermediate sequence of fiber spans with known losses and lengths. In the DWDM system, OSNR is an important parameter to be

considered before deciding the placement of the amplifier and setting the gain. OSNR is the ratio of the signal power to the noise power in an optical network. It is an important indicator for the performance of an optical network which limits the transmission distance. If the input power of an amplifier stage is lower, the OSNR will be better. But there will be a trade-off between OSNR improvement and the number of amplifier components used throughout the link. If an amplifier is placed at a lesser distance, this will increase the OSNR, but the distance covered will be less, and in order to compensate for the losses for the whole span, more amplifiers are needed, which will increase the design cost. Also, if a greater number of amplifiers are placed in a link power consumption of the link will be high [22].

Several EDFAs interconnected by fiber sections are used over a long transmission link to compensate for fiber attenuation. In this case, the gain of each amplifier is adjusted to compensate for the attenuation on one section of fiber. In doing so, optimal amplifier spacing becomes a question. Amplifier placement is a complex problem that depends on the effects of fiber nonlinearities, how the amplifiers are pumped and practical issues such as amplifier accessibility, cost, and others [14].

In this thesis, practical issues such as power consumption which is associated with cost and other physical implementation problems are considered for optimal line amplifier placement.

CHAPTER 3: Energy Consumption of Optical Networks

3.1 Introduction

Nowadays, WDM networks are deployed on large scale to form the backbone network infrastructure worldwide. According to [1] WDM technologies are accepted as robust and cost-effective means for supporting a huge amount of traffic demands and services at the lowest energy footprint possible. Optical technology can enable power savings up to 60% with respect to classical IP-over-WDM architectures with no optical switching [28]. WDM technologies can improve the scalability of network nodes in terms of power consumption. But due to usage inefficiencies, a considerable amount of energy is waste in an optical network.

The main reason for the usage inefficiency is the design and deployment of a network with peak hour traffic demand capacity and additional redundant resources for protection to ensure the reliability of the service carried by the network. The redundant resources are operational only when there is a fault in the network otherwise, they are idle. Amplifiers are also placed based on a pre-condition of power supply, shelter and other physical security availability requirements. All these conditions have resulted in a high power consuming network configuration.

3.2 Component Power Consumption

There are two different types of energy (power) associated with optical networks: Energy (power) required to transmit an optical bit and the power consumed by each component in an optical layer [29]. The interest of this thesis is on power consumed by optical layer components in the backbone infrastructure. Power consumption values for IP-over-WDM core network equipment were given in one report in 2012 based on publicly available data from product data sheets and different research papers [30].

In IP over the WDM network, the power consumption contribution of router ports that perform routing functionality in the upper layer is the most dominant one. Router ports have more than 90% power consumption contribution for IP over WDM network components [30]. Power consumption of a router ports in [3,11] is 1000w.

Transponders consume high power as compared to other optical layer components. For transmission rate of 40Gbps, transponders from different manufacturers consume different power values with and without management shelves. For example, Transmode (TM-4000) 40G transponder unit consumes 130w power, Transmode TM-4000 40G transponder unit + chassis consumes 158w and Tellabs 40 Gigabit Transponder Module (FGTM) consumes 167w power [30]. Typical power consumption values of Optical Transport Network (OTN) transponders with their respective transmission rates, including chassis, are shown in Table 3.1 below.

Table 3.1: Power consumption of transponders [30]

Transmission rate (Gbps)	Power consumption(w)
2.5	25
10	50
40	100
100	150
400	300

The power consumption value of OXC/ROADM includes the power consumption of Wavelength Selective Switches (WSS), multiplexer/de-multiplexer, booster and preamplifier, each with different power consumption value. The power consumption values of ROADM depend on node degree and add/drop degree. As node degree and add/drop degree increases the power consumption also increases. Node degree is the number of network connections terminating or originating from the node. A degree N node will have N optical terminal. Table 3.2 presents power consumption values for 40 channels OXC/ROADM based on the Cisco device as discussed in [30].

Table 3.2: Power consumption of OXC/ROADM [30]

Constitute components	Power consumption(w)
Wavelength cross-connect	$N \times 25$
Booster amplifier	$N \times 30$
Pre- amplifier (N x OPT-PRE)	$N \times 30$
Multiplexer	$D \times 20$
De-multiplexer	$D \times 20$

Where N is Node-degree, in ROADMs, number of network connections terminating or originating from the node and D is add/drop-degree.

As discussed in [30], individual optical amplifiers from different manufacturers use different power values. For example, Cisco unidirectional ONS 15501 EDFA uses 19.25w, from literature unidirectional EDFA uses 7.5w and unidirectional Raman amplifier uses 50w. These values are typical power consumption values. In addition to this, a complete amplification system with a maximum number of amplifier cards, controller cards and fans uses different power values based on the type of DWDM system under consideration. For example, the ultra-long-haul DWDM system uses 622w and the long-haul DWDM system uses a maximum value of 108w [30].

3.3 Power Consumption Minimization Approaches

As previously discussed in chapter one, usage of renewable energy sources and investigating energy consumption minimization approaches are the two main research directions, which are explored for minimization of Green House Gas (GHG) emission and energy cost [3]. Among the two main research directions, investigating energy consumption minimization approaches got increased attention. Telecom equipment vendors, researchers, and service providers are engaged in seeking power consumption minimization techniques for their equipment, component and network. Different researchers classify those energy-saving approaches differently. For example, green networking researches that focus on wired networking are categorized into four branches [8]:

1. Adaptive link rate: Works which propose turning off links during idle periods (sleeping mode) or reducing the line rate during low utilization period or rate switching.
2. Interface proxying: This branch consists of switching an inactive end device to the sleep/standby state and delegating the background processing either locally to the low-energy processor on-board of the Network Interface Card (NIC) of the same device, or an external entity.
3. Energy-aware infrastructure: This branch includes energy-aware applications and energy-aware routing, where making energy awareness during the design phase and traffic grooming are fall under this category.

4. Energy-aware software and applications: User-level applications and kernel-level network stack are addressed here. This is more of modifying the network operation according to the varying load imposed by the applications.

There are also other energy-saving approach categories [10]:

1. Re-engineering (replacing electronics by optics where possible), which gives more energy-efficient network elements
2. Dynamic adaptations (scale power consumption with actual load, e.g. dynamic voltage or frequency scaling),
3. Sleeping/standby (drive unused network devices to low standby modes).

Generally, in IP over WDM network, minimization of power consumption can be achieved through power-aware design and operation schemes of the network segment and the accompanying components. Through power-aware design scheme, many efforts have been done to optimize the physical topology of IP over the WDM network by taking power consumption minimization as an optimization objective as discussed in the literature review part. Besides, other energy-saving techniques are also investigated by many researchers and these approaches include energy efficient routing algorithms and traffic grooming.

To minimize the energy consumption of optical networks using a new energy efficient routing algorithm, clustered node architecture was proposed in [29]. This algorithm has a multipath selection approach for the implementation of sleep cycle protocols on optical nodes with the awareness of service threshold conditions and minimum energy consumption using an intelligent control plane only for static cluster selection. This energy efficient routing algorithm is proposed for any-cast routing which is implemented for the grid computing.

Energy-oriented IP over WDM network model, using MILP and heuristic approach for minimizing energy consumption based on traditional virtual topology optimization and traffic grooming design was developed in [18]. This model incorporates the energy consumption of network components and the layout of optical amplifiers in the design. Using this energy-optimized design, energy consumption reduction of 25% to 45% was achieved.

Many of the researches on power consumption minimization for IP over WDM network is formulated as a MILP problem (optimization problem) based on the multi-commodity flow model. This optimization problem minimizes the power consumption of cards and links or maximizes sleep mode power consumption of cards and links for energy saving.

An optimization problem is a problem that aims to find the best solution from all feasible solutions. An optimization problem can be solved by mathematical programming, a technique that expresses and solves problems as mathematic models. Linear Programming (LP) is a mathematical programming and a specific case of mathematical optimization which takes various linear inequalities and equalities to meet some constraints and determines the best obtainable result under those conditions. Integer Linear Programming (ILP) is a sub-category of linear programming where some or all the decision variables are integer values. If some variables in LP are an integer, then the LP problem is a MILP problem. Sometimes some of these variables can also be restricted to be either 0 or 1, which makes them binary variables [31]. The multi-commodity flow problem is a network flow problem with multiple commodities or flow demands between different source and destination use the same underlying network.

Optimization problem modeling is strongly correlated with the choice of optimization algorithms. That means the class of optimization algorithms available to solve a problem depends on how that problem is formulated. There are different optimization problem solution approaches such as analytical optimization approach, numerical optimization approach, experimental optimization approach and graphical optimization approach [32]: Among these approaches, numerical optimization approach fully utilizes the power of a computer as a computational workhorse. MATLAB which is a powerful computational modeling and coding tool can be used in this approach.

CHAPTER 4: Research Methodology

Network-level researches for investigating energy-saving approaches on IP over WDM and optical backbone networks followed similar methodologies. Physical topology optimizations in [3, 11], which are a design approach were done by performing assessment of operational and embodied power consumption of devices in the IP and optical layer and identify different constraints and decision variables. The optimization problem becomes a MILP problem with minimization of network operational power consumption and minimization of embodied power consumption of network devices.

Sleep mode operational strategy as applied to the optical backbone network for energy saving was assessed considering different constraints [10]. In this work, segment, card and link power consumption was analyzed. In addition, different constraints in addition to flow conservation constraints were identified and ILP was formulated. In,[34] MILP model was developed to minimize the power consumption of a core network. This model was developed by measuring possible card and chassis configurations power consumption of core routers. Finally, this data is used to optimize the deployment of card and chassis in the core network.

Optimization of amplifier placement for cost minimization was done before taking different amplifier types and predefined locations in a link [25]. This problem was formulated as MILP problem, where the number and type of amplifier cards were taken as decision variables and cumulative spontaneous emission noise was taken as constraint. In this case, the different types of amplifiers and cost of each type of amplifier were collected to be used as input parameter in the problem formulation.

In this thesis, similar methodology with the above mentioned works using one type of amplifier card and pre-defined locations for optimum optical line amplifier placement is used for power consumption minimization. This chapter gives steps that are followed to identify possible energy saving area and to formulate an optimization problem:

- Data is collected from ethio telecom documents such as Low-Level Design (LLD) and High-Level Design (HLD) document, network management system, Google maps using

(MAPS ME) and from product data sheet and literature. These data include the power consumption of the different cards, service demands, number of nodes, number of amplification sites, number of links, the distance between each node and length of fiber between each consecutive possible amplifier placement location (candidate points).

- Power consumption analysis is done for the total segment, for nodes and links considering the backbone network equipment deployed at ethio telecom. In this case, it is also realized that a single fiber pair is used to carry the total traffic in each link. This shows that defining the minimum set of routers and links that have to be used to support a given traffic demand is not feasible for energy saving in this network. So, another method should be identified to save energy in this scenario.
- After carrying out the identification of possible energy saving area and energy-saving method (i.e., optimal line amplifier placement), an optimization problem is formulated for this approach.

4.1 Experimental Network Topology

The case study is based on ethio telecom North circle optical backbone network. Ethio telecom has deployed different optical network technologies at a different time including traditional SDH, traditional WDWDM and ASON/OTN to expand the existing network coverage and capacity. The traditional DWDM (DWDM system without control plane) and SDH transmission technology were deployed throughout the country in 2007 [35]. This network has ring topology with two unidirectional fibers. Ethio telecom replaced the traditional DWDM network by OTN (ASON) network throughout the country in 2015. The topology type used in deploying the ASON network seems like a mesh network, but its connectivity level is low. The newly deployed ASON network (OTN with dynamic connection capability) supports advanced features like automatic switching and resource discovery. It supports different service configurations of type 40GE (Giga-bit Ethernet), STM (Synchronous Transport Module)-256, 10GE, STM-64, STM-16 and GE [19].

Ethio telecom's backbone network was designed and deployed only considering performance and reliability parameters basically for QoS provisioning. The newly deployed ASON network

has 1+1 dedicated path protection with restoration. Due to this dedicated protection scheme, the link utilization is not efficient which in turn results in energy wastage. Moreover, as discussed in the introduction part, in ethio telecom line amplifiers are deployed in a manner that additional power-consuming cards are required to fill shorter reach and to extend the EDFA reach (i.e., optical line amplifiers are placed between 25 to 120km spacing) in the link by considering physical end economic restrictions [19].



Figure 4.1: Topology of North-East optical backbone network [10]

4.2 Data Analysis

The optical backbone network segment is composed of different active components that consume power. The main components are listed in Table 4.1 with their respective power consumption value per card. This power consumption is a typical value.

Table 4.1: Power consumption of main optical components

Components	Notations	Power consumption(w)
Transponder	P_{tr}	99
Optical cross-connects	P_{Oxc}	70 (wss, mux,dmux. Amplifiers)
Mux/D-mux unit	$P_{m/d}$	20
Amplifier	P_{amp}	12/direction

In addition to the above-mentioned cards, optical network configuration is accompanied by additional components that are used for the healthy operation of the network. Table 4.2 shows typical OADM site configuration board types with their typical and maximum power consumption values. These power consumption values are essential for node and segment power consumption analysis.

Table 4.2: OADM site typical configuration and component power consumption [10]

No	Category	Board type	Typical power (w)	Maximum power(w)
1	OADM	Filter interface board	0.2	0.3
2	OADM	Inter leaver board	0.2	0.3
3	OADM	9-port wavelength selective switch multiplexing and de-multiplexing board	25.0	27.5
4	OADM	40 channel multiplexing board	10.0	13.0
5	OADM	40 channel de-multiplexing board	10.0	13.0
6	Tributary module	Interface board of alarm and timing	0,3	0.3
7	Tributary module	EMI filter interface board	5.0	7.0
8	Tributary module	Power interface unit	3.0	3.5
9	Tributary module	Synchronous timing interface board	1.5	1.5
10	Tributary module	Bidirectional optical supervisory channel and timing transmission unit	17.5	19.5
11	Tributary module	System auxiliary interface board	15.0	20.0
12	Tributary module	Clock board	?	?
13	Tributary module	System communication and control board	23.0	25.1
14	Tributary module	8-channel optical power monitoring board	12.0	15.0
15	OA	C-band optical booster unit (Max -1dBm IN and 16dBm OUT Gain 17dB	10.0	12.0

Continued from previous page

Table 4.3: OADM site typical configuration and component power consumption [10]

No	Category	Board type	Typical power (w)	Maximum power(w)
16	OA	C-BAND Optical Amplifier Unit (MAX 0dBm IN and 20dBm OUT, Gain 20 31dB	12.0	15.0
17	OA	C-BAND Optical Amplifier Unit (MAX 4dBm IN and 20dBm OUT, Gain 16 23dB	12.0	15.0
18	OTU	8x Any-rate Ports Service Processing Board	23.0	25.0
19	OTU	40GE Tributary Service Processing Board	58.0	64.0
20	OTU	40Gbit/s Line Service Processing Board	99.0	103.0

Table 4.4: OLA site component power consumption[10]

No	Category	Board type	Typical power (w)	Maximum power(w)
1	OADM	Filter interface board	0.2	0.3
2	Tributary module	Power interface unit	3.0	3.6
3	Tributary module	Bidirectional optical supervisory channel and timing transmission unit	17.5	19.5
4	Tributary module	System auxiliary interface board	9.0	13.0
5	Tributary module	System communication and control board	23.0	25.1
6	OA	C-BAND Optical Amplifier Unit (MAX 4dBm IN and 20dBm OUT, Gain 16 23dB	12.0	15.0
7	OA	C-band Raman and EDFA hybrid optical amplifier unit (MAX 1dBm line IN and MAX 20dBm OUT, Gain 19 to 33dB for G.652)	?	?

As shown above components deployed in OLA sites are few as compared to the Optical Add/Drop Multiplexer (OADM) sites. As a result, the power consumption of the OLA site is small. The total power consumption of a given optical backbone network segment is the sum of the power consumption of components deployed in each site within the segment. The sites can be configured as Optical Transmission Module (OTM), OADM, OLA or OADM/OTM. The total network segment power consumption is composed of power consumption of transponders, amplifiers, optical switches and multiplexer/de-multiplexer units as shown in Equation (2) [3,11].

$$P_{\text{total}} = P_{\text{Tra}} * T_n + P_{\text{OXC}} * \text{OXC}_n + P_{\frac{m}{d}} * m/d_n + P_{\text{amp}} * A_{m_n} * f_{pq} + P_o \quad (2)$$

Where, P_{Tra} is power consumption of transponder, T_n is the number of transponders, P_{OXC} is power consumption of optical cross-connect, OXC_n is number of optical cross-connects, $P_{\frac{m}{d}}$ is the power consumption of multiplexer/ de-multiplexer, $\frac{M}{D}n$ is number of multiplexer de-multiplexers, P_{amp} is power consumption of amplifier, A_m is the number of the optical amplifiers including a booster and preamplifiers, f_{pq} is the number of fibers between two neighboring nodes and P_o is over-head power, which is management shelf power.

Before trying to reduce energy consumption, a means should be identified to achieve a better energy saving [8]. Different energy-saving approaches are assessed from different kinds of literature. From ethio telecom network deployment and traffic demand perspective, sleep mode operation is feasible to save energy. But this approach is studied previously. Optimization of physical topology by the optimal deployment of physical links is another approach, which is done by many researchers for highly connected networks with high traffic demand. The energy-saving performance of this approach increases as network connectivity increases. This means this approach is not feasible for ethio telecom's current network deployment scenario.

In addition, many types of research recommended fixed spacing for optical line amplifier placement without considering physical and economic restrictions, which may not be feasible for

deployment. From current optical backbone network deployment perspective, ethio telecom experienced high power consumption in line amplifiers due to unavailability of supply power and shelter at each interval of 80km. To the best of our knowledge power consumption minimization using optimal line amplifier placement (placement location optimization) taking physical and economic restrictions in to account was not done before.

4.3 Optimal Line Amplifier Placement

Placement of EDFA depends on the span loss and the maximum gain that the EDFA has [22]. But in theory, placing amplifiers at 80km spacing is considered optimum both from performance and cost perspective [6]. On the other hand, green-field design of amplifier site is not common due to economic and physical restrictions [5]. Practically, amplifiers are placed in pre-defined locations along the link such that it can keep the performance and physical restriction requirements with the cost of high power consumption. According to ethio telecom current line amplifier deployment scenario, these pre-defined locations are cities along the fiber route, where the traditional SDH network was deployed. Each location has a span length (distance between amplifiers) ranging from 25 to 120km; that means each amplifier is placed within this spacing. But 25km spacing is very short and 120km spacing is relatively long, which needs attenuator card and high-power consuming card to fill the short reach and to cover the long reach respectively. During amplification site design, in addition to performance parameters considering cost, power consumption and heat dissipation is very important for economic and environmental benefits. Therefore, placement of an amplifier should be such that no more unnecessary line amplifiers must be needed further in the span and OSNR value at the receiver must be good enough.

In this thesis, an approach that optimizes placement of line amplifiers considering span length constraint in addition to input power level constraint at pre-defined possible amplifier placement locations is proposed. These pre-defined locations include Base Trans-Receiver Station (BTS) sites constructed for road coverage on top of small cities along the fiber route. In doing so, physical restrictions such as unavailability of supply power, physical security and shelter (if the BTS site is in-door) will be avoided. Furthermore, the number of OLA sites that will be deployed in a longer link may also be optimized due to span length constraint (i.e., span length within 80 –

100km range with the worst case condition 110km of upper bound) that avoids deployment of unnecessary line amplifiers in a link. This approach is formulated as a MILP optimization problem with minimization of amplifier card power consumption, where the power consumption is minimized over the 24h. Since a single amplifier card represents a single amplification point per direction in a single fiber pair link, this problem indirectly optimizes the number of amplifier sites.

4.4 Problem Formulation

To formulate the optimization problem, the distance between two nodes, set of links, the distance between two possible pre-defined locations, the power consumption of amplifier, number of wavelength channels, single-channel maximum output power and number of fibers are required. The number of fibers in many types of research is taken as a decision variable determined by the number of wavelength channels required between source/destination node pairs and the maximum wavelength channel supported by a link. This number of fibers is in turn used to determine the number of amplifiers placed at one point in a link.

In an optical link, multiple wavelengths or light paths are combined into wavelength bands. Bands are combined to produce a composite WDM signal on a fiber [15]. Line amplifiers amplify the composite signal of the WDM link simultaneously. This composite power is a combination of each channel's power and it can be expressed mathematically as Equation (3) below [19]:

$$p_c = p_s + 10 \log_{10} n \quad (3)$$

Where ($n = 1 \dots W$)

This equation is for “n” wavelengths with the same optical power level. Where, P_c is the combined power, P_s is the single-channel launched power and W is the maximum number of wavelength channels supported by the system.

Table 4.5: Notations and descriptions of input parameters

Notations	Descriptions
I	Set of links ($i = 1, \dots, I$)
f_i	Number of fiber on each link/direction
N	Set of nodes, 23
J	Set of possible amplifier placement locations on a link ($j = 1, \dots, 5$)
L	Length of a link
K	The total number of amplifiers to be placed at each link
P_j	Measured power level at any point j
L_j	Length of fiber between point j and $j - 1$
α	Attenuation coefficient, 0.27dB/km
pa	Power consumption of an amplifier card, 12w/direction
w_{pq}	Number of wavelength channels in the physical link
P, q	End points of physical link
W	Maximum number of wavelength channels, 40channels
y, z	End points of virtual link
C	Maintenance margin including connector loss, 2dB
f_{pq}	Number of fibers between two end points of a physical link

Table 4.6: Decision variable notation and description

Notation	Description
x_j	Amplifier placed at point j , binary
PL_k	Span Loss of the k^{th} span length in a link
SL_k	Span Length of the k^{th} amplifier in a link

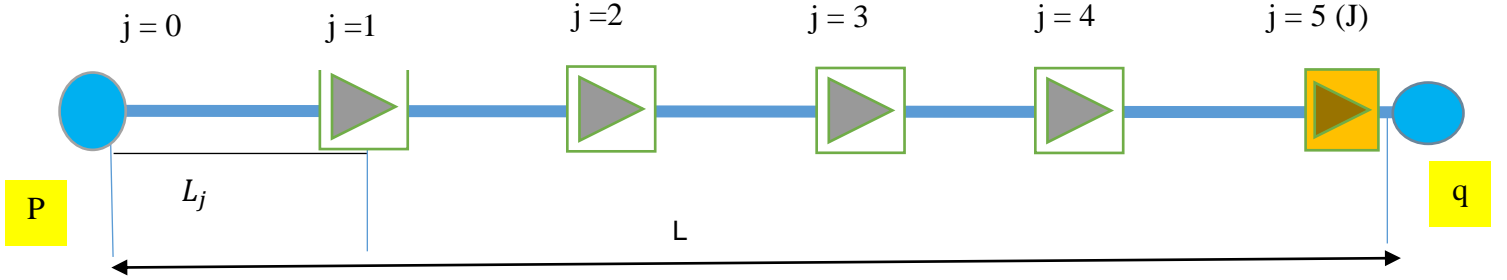

Figure 4.2: Representation of a physical link

The above figure (Figure 4.2) represents the layout of a physical link with two neighboring node p and q, length L and five sets of points each with length L_j from each other. Points from (j = 1 to j = 4) represents candidate pre-defined locations for line amplifier placement, which satisfies all physical requirements. The last point (J) represents pre-amplifier location. With the given input parameters (L_j) and decision variables (Tables 4.3 & 4.4) above, the optimization problem can be formulated as Equation (4) below to minimize total power consumption of optical backbone network. Since it considers a binary variable x_j that denotes the amplifier state at a given location (j) in a link, the optimization problem is MILP with an objective function of power consumption minimization for amplifier cards. Equations (5)-(8) below are constraints of the MILP problem.

Objective function: Minimize

$$\sum_{i=1}^I \sum_{j=1}^J x_{ji} \cdot Pa \cdot f_i$$

(4)

$$x_j = \begin{cases} 1, & \text{if amplifier is placed at point } j \\ 0, & \text{otherwise} \end{cases}$$

Subject to constraints:

$$\sum_{y \in N} \sum_{z \in N, y \neq z} w_{pq}^{yz} \leq W \cdot f_{pq} \quad (5)$$

$$\forall y \in N, z \in N, y \neq z$$

The constraint in (5) represents a link capacity constraint, where the total number of wavelength channels in virtual links that traverse a physical link should not exceed the capacity of fiber in the physical link.

$$SL_k = \sum_{j=1}^J L_j \cdot x_m$$

$$\text{If } \begin{cases} SL_k < 80, x_j = 0 \ \& \ x_m = 1, m \leq j \\ SL_k \geq 80, x_j = 1 \ \& \ x_m = 0, m \leq j \end{cases} \quad (6)$$

x_m is dummy variable and it is inverse of x_j such that $x_m = 0$, when $x_j = 1$

Without loss of generality, we assume the optimum upper bound for span length (SL_k) to be 100km and taking the worst case condition of upper bound for line amplifier placement 110km, SL_k is span length of the k^{th} amplifier ($k=1, \dots, K$)

It is assumed that no line amplifier is needed at point 0 and K is an amplifier placed at point J and it represents a pre amplifier. SL_k is the optimum span length for line amplifier placement to minimize power consumption, which is the k^{th} span length. Value of x_j will be 1, if this span length is within the required range.

The constraint in (6) limits span length range to avoid usage of extra unnecessary amplifiers in a physical link and to avoid usage of attenuator cards in unnecessary place when it is very short. If this span is very long the signal will be degraded into a level that is difficult for detection, so

upper bound is set up to 100km for optimal placement. Span length above 100km is controlled by the solution finding algorithm. This span length constraint is suited for placement of the same type of line amplifier in a link.

$$PL_k = \sum_{j=1}^J L_j \cdot \alpha \cdot x_m + c$$

$$\text{If } \begin{cases} PL_k < 24, x_j = 0 \ \& \ x_m = 1, m \leq j \\ PL_k \geq 24, x_j = 1 \ \& \ x_m = 0, m \leq j \end{cases} \quad (7)$$

Where, PL_k is the allowable path loss that can be compensated by the k^{th} amplifier gain in a physical link. Without loss of generality the optimum upper bound for path loss to be 31dB and taking the worst case path loss to be 32dB. An amplifier x_j will be 1, if this loss is within the acceptable range.

The constraint in (7) ensures that span loss at each amplifier location to be in the acceptable range so that the signal can be amplified in a proper way. In this case the measured power level constraint is included indirectly. The measured power value at any point (j) in a link is the difference between the launched power and loss that the link exhibits due to different loss factors. This loss is called channel loss and it includes fiber attenuation loss, connector loss and splice loss.

Today's technology supports Automatic Level Control (ALC) function and this function can be configured in a network to automatically adjust the output power of amplifier according to the line loss variation, (i.e., the gain of the in-line amplifier can be adjusted to compensate the loss of each span).

The total number of amplifiers/direction in a link can be given as:

$$K = \sum_{j=1}^J x_j$$

$$\sum_{k=1}^K SL_k = L \quad (8)$$

Where, SL_k is span length of the k^{th} amplifier ($k=1, \dots, K$)

The constraint in (8) ensures that the summation of all span lengths in a given link should be equal to the link length.

In this thesis, the number of fiber per direction is 1. This is because; the number of fiber between node pairs in ethio telecom condition does not exceed single fiber pair. Besides, this thesis focuses on the location where each line amplifier is placed in a physical link rather than the number of amplifiers at a point.

This optimization problem is formulated to place line amplifiers at span length from 80 – 100km spacing in contrary to those research works, which place line amplifiers at a fixed spacing of 70/80km. But there are also worst case condetions that amplifiers are placed at span length of upto107km considering the worst case path loss. Generally, this problem tends to provide power consumption minimized topology by decreasing the number of amplifier sites in the network and it avoids physical restrictions by using pre-defined placement locations that have supply power and shelter within the 80 – 100km range.

The solution finding process is required to be completed in few minutes, which requires efficient algorithms and techniques such as an exact optimization technique that can find a solution for the whole link at a time and converges within few minutes for small network size. But the solution approach in this thesis will not meet this requirement. The main reason for this is the need for fiber span resetting after amplifier placement and non-uniformity of fiber lengths for the available possible amplifier placement locations. As a result, MATLAB is used to find the optimum placement location on a link by link base. The solution finding process used search algorithm that can find the appropriate span length for line amplifier placement by adding the input parameters. After carrying out the placement optimization, total amplification point is determined and then the power consumption of amplification sites using the different placement approaches is analyzed.

CHAPTER 5: Results and Discussions

This chapter describes results (findings) and discussions. In this thesis, the optimization problem solution is segmented into two parts: amplifier placement and power consumption analysis part.

- The amplifier placement part takes data in Tables 5.1 below as an input parameter and gives proper amplifier placement location based on the constraints. For the theoretical approach (80km spacing) link lengths in column 1 of Table 5.4 are used to determine the number of amplifiers required in each link.
- The power consumption analysis part shows power consumption analysis results of OLA sites board configuration for the placement optimized, existing configuration, and theoretical standard (80km spacing). In addition, the power consumption of the network segment is analyzed for the three placement approaches.

5.1 Amplifier Placement Results

The case study is based ethio telecom North circle optical backbone network topology that consists of a total of 30 links, 23 nodes and service demand of 42. Among these 10 links do not need amplifier site; since the link length is shorter than 90km [19]. Distance between pre-defined locations (set of points) for this network topology is given in Table 5.1 below.

Table 5.1: Distance between two pre-defined locations

Link assignment	Distance between two possible amplifier placement points (km)				
	L_1	L_2	L_3	L_4	L_5
1	45	43	31	27*	40
2	65	30*	43	21*	21
3	59*	26*	64*	29*	73
4	35	61	52	43*	92
5	38	42	51	44	50
6	42	39*	25	30	21
7	47	40*	80*	94*	43
8	42	45*	5*	47	5
9	80*	60	33*	52	40
10	97*	90*	76*	84*	98
11	38*	52	36	13*	40
12	37*	55*	25*	26*	43
13	92*	83*	25*	39*	31
14	37	37	17	26	37
15	65	30*	34*	53*	20
16	30	24	38	17*	15
17	85	27	80	Difficult to find adjacent points	
18	37	33	13	33*	11
19	41	31	22	15	10
20	27	32	19	25	16

➤ * indicates BTS site locations

In addition to fiber length, other physical layer parameter such as line amplifier type is also considered in this thesis. Amplifier card with a variable gain range of 24dB – 31dB and input power range of -32dBm to -16dBm and typical launch power of 0dBm are used for case study. The maximum link capacity is assumed to be 40 wavelength channels each with a capacity of

40Gbps. In this thesis, the acceptable span loss is from 24dB and 31dB and acceptable span length is from 80km and 100km; but there is tolerance of 10km for span length and 1dB for span loss.

5.1.1 Placement Result of New Approach

The placement optimization result takes into account the input power level to line and pre-amplifiers and fiber span constraint. It also fulfills the physical requirements. Table 5.2 shows few examples of how the placement task is performed with the given parameter and constraints.

Table 5.2: Sample amplifier placement problem solution

Link assignment	Distance between two pre-defined points (km)	Per channel input power level(dBm)	Amplifier card value at point j	Attenuator card demand
Link 1	45	-13.5	0	
	43	-28.4	1	
	31	-9.3	0	
	27*	-17.4	0	
	40	-30.5	1	
Link 7				
	47	-14.1	0	
	40*	-28.1	1	
	80*	-26.0	1	
	94*	-30.2	1	
	43	-15.1	1	1

The above table shows decision variable and parameter values. The first column is the link assignment. The second column is the input parameter for the placement optimization that is the fiber length in km between two consecutive points for each link, which is taken from Google Maps. Some of the points are cities located along the fiber route and others are BTS sites indicated with (*) in Table 5.2 above.

The third column represents the per channel input power level expected to be measured at the receiving end of the line and pre-amplifiers taking span length from 80 - 100km and attenuation coefficient of 0.27dB/km. This per channel power level can be computed using Equation (9) below.

$$P_j \text{ (dBm)} = P_s + 10\log_{10} W - PL_j \quad (9)$$

Where P_j is the measured power level at point j , $P_s + 10\log_{10} W$ is the composite power and PL_j is the fiber span loss.

The per channel output power of an amplifier in an N channel DWDM network is given by using

$$P_{out} \text{ (dBm)/channel} = P_j \text{ (dBm)/channel} + \text{Gain (dB)} \quad (10)$$

Splicing loss of 0.05/ splice and a loss margin of 2dB per span is also added to overcome connector loss and as a maintenance margin. Amplifier placed at any point j will compensate all the previous span losses. At this point, the span length will be reset, and new span length computation will start again for the next placement location decision.

The fourth column shows the decision variable values, which is a binary value; with a value one (1) for amplifier assigned at a point j and a value zero (0) otherwise. In this case, amplifier value at point (J) represents pre-amplifier but not a line-amplifier. The last column shows attenuator card demand for one direction analysis based on the input power level. Few points require attenuator card with an attenuation range of 0 to 15dB.

Table 5.2 above shows the values of one direction analysis. The reverse direction values are analyzed in the same manner. Attenuator cards are also necessary for the reverse direction to fill shorter reaches to maintain back to back deployment of amplifier cards.

Overall amplifier placement results for the 20 links are given in Table 5.3 below in the form of the binary value.

Table 5.3: Amplifier placement results of the new approach

Link assignment	Amplifier value at any point j				
	$j = 1$	$j = 2$	$j = 3$	$j = 4$	$j = 5$ (J)
1	0	1	0	0	1
2	0	1*	0	0	1
3	0	1*	0	1*	1
4	0	1	0	1*	1
5	0	1	0	1	1
6	0	1*	0	0	1
7	0	1*	1*	1*	1
8	0	1*	0	0	1
9	1*	0	1*	0	1
10	1*	1*	1*	1*	1
11	0	1	0	0	1
12	0	1*	0	0	1
13	1*	1*	0	0	1
14	0	0	1	0	1
15	0	1*	0	1*	1
16	0	0	1	0	1
17	1	1	1		1
18	0	0	1	0	1
19	0	1	0	0	1
20	0	1	0	0	1

➤ * indicates line amplifiers placed at BTS sites

Table 5.4: Amplifier placement analysis result for 80km interval

Link distance (km)	No of amplifiers required	Number of attenuators	power consumption (w)
117	1	1	37
182	2	1	61
127	1	1	37
144	1	-	24
180	1	-	24
105	1	1	37
202	2	1	61
200	2	-	48
270	3	1	85
251	2	-	48
283	2	-	48
302	3	-	72
124	1	-	24
186	2	1	61
261	3	1	85
101	1	1	37
176	2	1	61
423	5	1	123
154	1	-	24
26	-	1	13
157	1	-	24
225	2	-	48
45	-	1	13
192	2	1	37

5.2. Power Consumption Analysis Results

In this section, the power consumption of OADM/OTM sites (Nodes site) and OLA sites are analyzed using realistic figures, which is derived from available products deployed at ethio telecom North circle optical backbone network.

5.2.1 Power Consumption Analysis Result of New Approach

As shown in Table 5.3 above, there are a total of 32 OLA sites each with a board configuration power consumption of 148w including management shelf power. There are also 8 variable attenuator cards from both direction analyses.

From this,

- Total power consumption of amplifier sites board configuration is 4,736w
- Total power consumption of attenuator cards is 52w
- Overall power consumption for the 32 amplification site board configuration is:

$$4,736w + 52w = 4,788w = 4.788kw.$$

As discussed before, there are 23 nodes (OADM/OTM) sites in the North circle optical backbone network. The power consumption of the node site is very large as compared to the OLA site. Pre and booster amplifiers are part of the node site and their power consumption is included in the node sites. The total node power consumption of the North circle optical backbone network is 53,900.1w. This value does not include cooling system power.

By assuming that the node power consumption is constant, the total target network board configuration power consumption using the new placement approach is:

$$53,900.1w + 4,788w = 58,688.1w = 58.6881kw$$

5.2.2 Power Consumption Analysis Result of 80km Interval

As indicated in Table 5.4 above, the amplifier placement task using the theoretical placement approach gives a total of 41 amplification locations and 14 attenuator cards for the two-direction

analysis. The need of attenuator cards can be determined by the fiber length between sites or measured power level at the input of amplifiers. In this thesis, power consumption of amplification sites based on the theoretical standard is:

- Power consumed by attenuator and amplifier cards is 1,132w.
- Power consumed by management shelf of 41 amplification sites is 5,084w

Total power consumption of the 41 amplifier sites board configuration is:

$$1,132w + 5,084w = 6,216w = 6.216kw.$$

The total target network board configuration power consumption is:

$$53,900.1w + 6,216w = 60,116.1w = 60.1161kw.$$

Where, the node power is constant.

5.2.3 Power Consumption Result of Existing Configuration

Existing North circle optical backbone network topology of ethio telecom consists of 37 amplification locations. These amplification sites are deployed considering previously mentioned physical and economic restrictions such as availability power supply and shelter. In this case,

- Amplifier and attenuator cards consume 1,228w power
- Management and communication board configurations consume 4,588w
- 5 additional high-power consuming cards (Raman cards) consume 215w power

Summing up these values, the amplifier site board configuration of the existing network consumes a total of 6,031w.

The total target network power consumption of the existing configuration is:

$$53,900.1w + 6,031w = 59,931.1w \text{ or } 59.9311kw.$$

From the above amplifier placement and power consumption analysis results, if amplification sites are deployed using the new placement approach, the number of amplifier sites and the

power consumption are minimized, This result is summarized in table 5.5 below taking comparison of the different placement approach.

Table 5.5: Result Summary

Amplifier site placement approach-pairs	Number of site minimization	Power saving (w)
Theoretical standard- new approach	$41 - 32 = 9$	$6216 - 4788 = 1428$
Existing config- new approach	$37 - 32 = 5$	$6031 - 4788 = 1243$

In this thesis, only one fourth (1/4) of the operator network topology is considered for case study purposes. Amplifier site deployment using the new approach can minimize number of amplification sites by 9 as compared to the theoretical standard and by 5 as compared to the existing configuration and power saving of 1428w and 1243w can be achieved over the 24hours as compared to the theoretical standard and existing configuration respectively.

5.3 Discussion

In this section power consumption contribution of amplification sites to the total segment power and power-saving performance of the new placement approach are evaluated with respect to the theoretical standard and existing configuration.

5.3.1 Power Consumption Contribution

When amplifiers are placed based on the theoretical standard (at 80km spacing), the signal quality and in turn system performance will be good enough; but the number of amplifier site and the power consumption of the network is greater. Figure 5.3 below shows the total segment power consumption using different amplifier sites placement scenario. From this figure it can be seen that taking the node power consumption constant, more power is consumed when amplification site is deployed using the theoretical approach and less power is consumed when deployed using the new approach. This is because, the new approach is formulated using line amplifier placement spacing ranging from 80 – 100km, which completely avoids usage of extra

unnecessary amplifier in each link. In this case, a fiber length difference of about 20km at each span length between the new placement approach and theoretical recommendation has made such a power consumption difference.

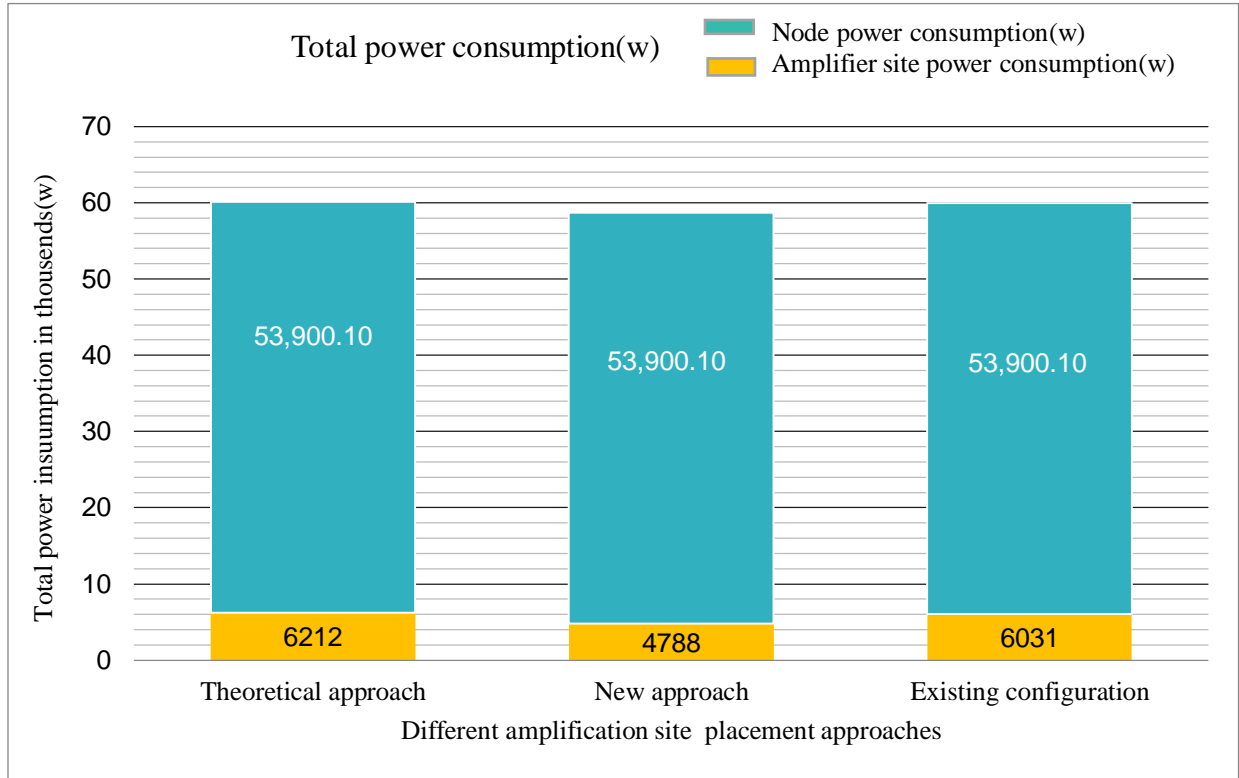

Figure 5.2: Total segment power consumptions

Different research on IP over WDM network assumed the power consumption contribution of the amplifier to be less than 3%. This value is based on a single amplifier card when it is compared with the router port and transponder card power consumption as discussed in the motivation part. But when amplifier site power consumption is considered, the power consumption contribution of the amplifier sites is reached up to 10% for the theoretical placement approach as shown in the pie chart (Figure 5.4) below. This result is supported by another work in [2], “about 90%, of the core network power consumption is concentrated in the nodes. The WDM links, by way of the optical amplifiers, make up only around 10% or less of the power consumption”. In this thesis, the power consumption contribution of the theoretical and the existing configuration is almost similar even with 5 site difference; this is because high power consuming cards are incorporated in the existing amplifier site configuration

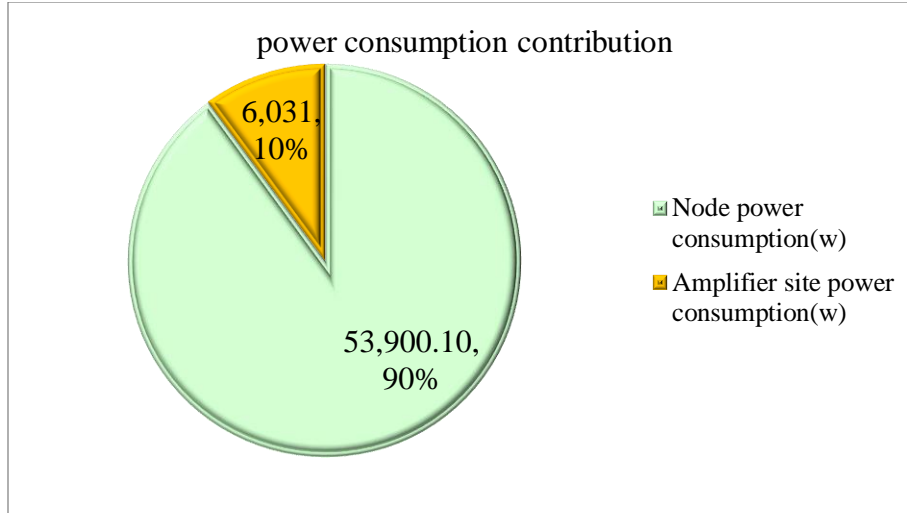

Figure 5.3: Power consumption contribution of amplification sites

Actual deployment of line amplifiers considered preconditions such as availability of power supply and shelters to house the equipment. To fulfill these pre-conditions amplifiers are placed at a location where there is supply power and shelter in conjunction with other equipment. Thus this leads to a lesser number of amplifier sites in some links as compared to the recommended standard which in turn makes the power consumption of the link to be less. This scenario is seen in this thesis; (i.e., there are 37 amplification sites in the existing configuration of North circle backbone network topology, but the number of amplification sites reach 41 by using the theoretical standard). Accordingly, the power consumption of the existing configuration, even with additional high power-consuming cards is smaller as compared to the theoretical recommendation as shown in Figure 5.3 above.

5.3.2 Power Saving Performance

In this subsection, the possible power savings of the new amplification site placement approach will be analyzed using ethio telecom North circle backbone network topology.

Total network segment power consumption is the sum of power consumption of nodes and OLA sites. 90% of the power in optical backbone network is consumed by boards deployed in OTM/ROADM sites and only 10% is consumed by amplifier sites. Due to less power consumption contribution of amplification sites, the power saving using the new placement

approach is 2% ($1 - (58.6881\text{kw} / 59.9311\text{kw})$) of the total segment site power consumption or 20% ($1 - (4788/6031)$) of amplifier site power consumption. But this value is significant when it is applied in large size networks. For example, For example, ethio telecom optical backbone network consumes about 1.3MW power [19]. A 2% saving from this value means 26kw power can be saved all the time. But the case study optical backbone network is (1/4) of the total backbone network and consumes about 59.9311kw power. A 2% saving from this value means 1.202kw power can be saved all the time.

To analyze the cost saving due to this line amplifier site placement optimization, few assumptions are considered

- This power consumption minimization approach is a design approach and it can save power all the time.
- The life time of the deployed component is assumed to be six (6) years.

The annual energy cost of the existing case study network portion of the optical backbone network card configuration taking Ethiopian Electric Utility general tariff flat rate (1.7611Birr/kwh) as of December, 2020 is given below [36].

$$\text{Annual energy cost of existing case study network} = 924,571.22344 \text{ Birr.}$$

When amplifier sites are configured using the new placement approach, the annual energy cost of this case study portion can be reduced to 905,395.17Birr.

The total annual cost saving due to usage of the new amplification site placement approach is:

$$924,571.22344 \text{ Birr/year} - 905,395.17 \text{ Birr/year} = 19,176.5 \text{ Birr}$$

For the total life time 115,056.32 Birr saving can be achieved for only energy cost. But the optimization has dual benefit that it can also minimize capital and operational costs; if the site deployment and site maintenance cost is included, the cost saving will be significant. In addition, it reduces the Green House Gas emission and associated heat dissipation challenge

Generally, this thesis work investigates, evaluates and proposes new line amplifier placement techniques that can be applied in an operator network during design phase to minimize power consumption, capital and operational cost of optical transport networks.

5.4 Implementation Strategy

Usually, there is a tradeoff between power saving and QoS or power-saving and implementation challenges. Even though the power saving achieved in this thesis work is significant for large size networks, there are challenges that should be managed before incorporating the proposed approach on the already deployed network. For example, the BTS site that is used to “co-site” with an amplifier site may be an outdoor site and there may be no shelter with a cooling system to house the newly arriving equipment. Besides, fiber junction may be needed, if the BTS site and the fiber are not aligned.

But, if the cost-saving due to number of amplifier site minimization is compared with the cost incurred due to the addition of rack, cooling system, and shelter, amplifier site deployment using the new approach is preferable. For the Greenfield design of the optical transport network (backbone network) and cellular network, the above-mentioned challenges can be considered during network design phase and there may be no such problem.

CHAPTER 6: Conclusion and Future Work

6.1 Conclusion

In line with traffic volume increase, telecom operators continuously increase their network carrying capacity by expanding their network infrastructure using deployment of additional component or by upgrading the card capacity. As a result, the power consumption of telecommunication networks increase. This power consumption increment has impact both on the economy and the environment. To mitigate this power consumption increment, two main research detections are being explored by stakeholders. These research directions are categorized into usage of renewable energy source and investigating power consumption minimization approaches. Different power consumption minimization approaches have been investigated to save energy in telecommunication network. These approaches are categorized into energy- aware network design and energy-aware network operation approaches.

Researchers are made efforts dedicated to reduce unnecessary energy waste in backbone networks. Among those efforts IP over WDM network physical topology optimization for power consumption minimization can be mentioned. But this optimization mainly focuses on defining the minimum set of router ports, transponders and number of fiber that can support a given traffic demand for highly connected networks with high traffic demand to achieve better energy saving, which is not feasible for low connected networks like ethio telecom. In addition, in these research works amplifiers are placed at regular interval of 80km without considering physical and economic restrictions. But in practice, amplifier placement is commonly implemented by operators to guarantee a signal quality considering placement location with availability supply power, shelter, and physical security with the expense of high power consumption. Current ethio telecom line amplifiers are placed at span length ranging from 25 to 120km considering these physical and economic restrictions; due to this, ethio telecom experiences high power consumption in line amplifiers.

In this thesis, a MILP formulation which takes span length and measured (input) power level constraint based on energy-aware network design approach is investigated and proposed to save energy in an optical backbone network. The proposed power-saving approach is evaluated

considering ethio-telecom North circle optical backbone network topology. MATLAB is used to assign optimum placement location. The optimized topology is compared with theoretical (80km spacing topology) and the practical (existing network topology) using number of amplification sites and power saving performance. The comparison results show that using the new placement approach can minimize the number of amplification sites by 9 from the theoretical approach and by 5 from the existing configuration and a 2% power saving can be achieved in the case study network portion.

The above results and discussions show that:

- If power optimization is applied in a link on amplifier site level, significant amount of power can be saved for large size networks with link lengths in thousands of kilometers; because as the link length increases, the number of amplifier sites required to cover the whole length will be larger and power saving will be better.
- If amplifiers are placed based on the new placement approach (by setting pre-defined locations) that fulfills necessary technical requirements, physical and economic restrictions will also be avoided.
- The new approach provides flexibility to adjust a span length based on the loss accumulated in the span, fiber type and amplifier type; which is not the case in the theoretical approach.

Generally, this line amplifier placement approach can be applied to save energy and to reduce operational (energy and site maintenance cost) and capital cost (site deployment cost) for a company. In addition, it provides design flexibility for an operator network by varying span length based on the link loss (type of fiber) and type of amplifier card used.

6.2 Future works

This work is a starting point for power saving in the optical backbone network using a design approach. It can be expanded by doing the analysis for the whole network segment using additional constraints (environmental condition) constraint. In addition, efficient algorithm that can solve this optimization problem at a time is required.

References

- [1] Esther Le Rouzic, Edoardo Bonetto, Luca Chiaraviglio, Frederic Giroire, Filip Idzikowski, Felipe Jiménez, et al., “Trend towards more energy-efficient optical networks,” in *17th conference on Optical Network Design & Modeling (ONDM)*, Brest, France, 2013.
- [2] Willem Vereecken, Ward Van Heddeghem, Margot Deruyck, Bart Puype, Bar Lannoo, Wout Joseph, et al., “Power consumption in telecommunication networks: overview and reduction strategies,” *IEEE communication magazine*, volume 49, issue 6, pp.1-6, 2011.
- [3] X. Dong, T. E. H. El-gorashi, J. M. H. Elmirghani, and S. Member, “On the energy Efficiency of physical topology design for IP over WDM networks,” *Journal of light wave technology*, vol. 30, no. 12, pp. 1931–1942, June 15, 2012.
- [4] George Koutitas and Panagiotis Demestichas, “A review of energy efficiency in telecommunication networks,” *Telfor Journal*, Vol. 2, No. 1, pp. 2-7, 2010.
- [5] Yi Zhang, Pulak Chowdhury, Massimo Tornatore, and Biswanath Mukherjee, “Energy-efficiency-in-telecom-optical-networks,” *IEEE Communications Surveys & Tutorials*. Volume: 12, Issue: 4 , pp 441 – 458, July, 2010.
- [6] Jorge López Vizcaíno, “Energy-efficient design of optical transport Networks,” Ph.D. dissertation, Technical University of Dortmund, Munich, 2016.
- [7] R. Bolla, R. Bruschi, F. Davoli and F. Cucchietti., “Energy Efficiency in the future Internet: A survey of existing approaches and trends in energy-aware fixed network infrastructures,” *IEEE Communications Surveys and Tutorials*, vol.13, no.2, pp.223-244, 2011.
- [8] A. P. Bianzino, C. Chaudet, D. Rossi, and J. Rougier, “A survey of green networking research,” *IEEE Communications Surveys & Tutorials*, vol. 14, no. 1, pp. 3–20, Dec. 2012.

- [9] Future networks: Objectives and design goals, ITU-T, Standard Y.3001 (05/2011).
- [10] Yohannes .B and Yalemzewd. N. “Sleep mode operation of optical networks for energy consumption minimization: a case study of ethio telecom backbone optical transport network,” M.Sc.Thesis, Depart., Elect. &Comp. Eng., AAIT, Addis Abeba, Ethiopia, 2018.
- [11] X. Dong, A. Lawey, T. E. H. El-gorashi, J. M. H. Elmirghani, and U. Kingdom, “Energy efficient core networks, ” in *IEEE 16th International Conference on Optical Network Design and Modeling (ONDM)*, Colchester, UK , 2012, pp 1-6.
- [12] Jorge López Vizcaíno¹, “Amplifier placements optimization for enhanced energy Efficiency in optical transport networks,” in *IEEE International Conference Communications (ICC)*, Sydney, NSW, 2014, pp. 3700-3706.
- [13] Govind p. Agrawal, *Fiber-Optic Communication Systems*, 3rd ed. New York: John Wiley & Sons Inc, publication, 2002.
- [14] *Optical amplifier in fiber-optic-communication-system* [online]. Available: <https://www.fiberoptics4sale.com/blogs/archive-posts/95044614>.
- [15] Rajiv Ramaswami, Kumar N. Sivarajan and Galen H. Sasaki, *Optical Networks*, 3rd ed. USA: Morgan Kaufmann, 2010.
- [16] Cisco “cisco ONS 15454 Engineering Planning Guide” [online]. November 2009. Available. <https://www.cisco.com>. [Accessed, 10-April-2019].
- [17] Ward Van Heddeghem, Filip Idzikowski*, Willem Vereecken, Didier Colle, Pickavet, Piet Demeester, “Power consumption modeling in optical multilayer networks,” *Photonic Network Communications*, vol. 24, pp. 86-102, 2011.
- [18] G. Shen and R. S. Tucker. (2009, June). “Energy-minimized design for IP over DWDM networks,” *Journal of Optical Communications and Networking*, vol. 1, No. 1, pp. 176-186, June 2009.

- [19] Ethio telecom, “Low Level Design for LOT-4 DWDM AA, Northern, Eastern, Somali Regions Backbone Transmission Project,” unpublished
- [20] Jane M. Simmons, *Optical Network Design and Planning*, 2nd ed. Switzerland: Springer International Publishing, 2014.
- [21] John m. Senior, *Optical Fiber Communications Principles and Practice*, 3rd ed. London: Pearson Education Limited, 2009.
- [22] Soumya M Sajjan, Vikram Seshasai, Dr. G. Sadashivappa, “DWDM link design and power budget calculation,” *International Journal of Advanced Research in Electrical, Electronics and Instrumentation Engineering*, Vol. 4, Issue 4, pp. 2538 – 2548, April 2015.
- [23] Jane M. Simmons “Network design in realistic ‘All-Optical’ backbone networks,” *IEEE Communications Magazine*, vol. 44, no. 11, pp. 88-94, November 2006.
- [24] Pawan Kumar Dubey, Vibha Shukla, “Dispersion in optical fiber communication,” *International Journal of Science and Research (IJSR)*, Volume 3 Issue 10, pp. 236-239, October 2014.
- [25] Ye Tao, J.Q. Hu, “Optimal amplifier placement for optical networks,” Depart. Manufacturing Eng., Boston University, Available: URL <https://www.researchgate.net/Publication/268398229>, [Accessed:4-May-2019].
- [26] Admin. (2017). *How to place EDFA for DWDM distance extension* [Online]. Available: <http://www.fiber-optic-solutions.com/>, [Accessed: 8- May- 2019].
- [27] Venkat Venkata Ramanan, “Optical amplifiers,” Institute of Optical Sciences University of Toronto. Available: <https://www.ee.ryerson.ca/~courses/ee8114/>, [Accessed: 3-July-2019].
- [28] Francesco Musumeci, Massimo Tornatore, and Achille Pattavina, “A power consumption analysis for IP-over-WDM core network architectures,” *Journal of*

Optical Comm. Networks, vol. 4, no. 2, February 2012.

- [29] B. G. Bathula and J. M. H. Elmirghani, “Green networks: energy efficient design for optical networks,” in *IFIP International Conference on Wireless and Optical Communications Networks*, Cairo, Egypt, 2009.
- [30] Ward Van Heddeghem, Filip Idzikowski, “Equipment power consumption in Optical multilayer networks – source data,” Dept. Info. Tech., Ghent University Belgium, Report Number: IBCN-12-001-01, January 12th, 2012. *Communications*, Helsinki, Finland, 11-14 June 2001.
- [31] Eiji Oki, *Linear Programming and Algorithms for Communication Networks, A Practical Guide to Network Design, Control, and Management*, Boca Raton: CRC press: Taylor & Francis Group, 2013.
- [32] Achille Messac, *Optimization in practice with matlab® for engineering students and Professionals*, New York: Cambridge University Press, 2015.
- [33] Ling Zong, Byrav Ramamurthy, “Optimization of amplifier placements in switch based Optical networks,” in *IEEE International Conference on Communications*, Volume: 1 pp 224 – 228, 2001. Available: <http://digitalcommons.unl.edu/cseconfwork/119>
- [34] J. Chabarek, J. Sommers, P. Barford, C. Estan, D. Tsiang, and S. Wright, “Power Awareness in network design and routing,” *Proceedings IEEE INFOCOM*, pp. 1130-1138, 2008.
- [35] Lishan Adam. *Ethiopia Telecommunications Sector Performance Review 2007(1)* [online]. Available: www.researchICTafrica.net
- [36] EEU. (2018). *Current tariff* [online]. Available: www.eeu.gov.et/index.php.

