



ADDIS ABABA UNIVERSITY

ADDIS ABABA INSTITUTE OF TECHNOLOGY

Department of Electrical and Computer Engineering

**Feasibility Study of Renewable Energy Resources
for Electrification of Small Islands.
A Case Study on Tana Lake Islands**

**A thesis Submitted to Addis Ababa Institute of Technology, School of Graduate
Studies, Addis Ababa University**

**In partial Fulfillment of the Requirement for the Degree of
MASTER OF SCIENCE IN ELECTRICAL AND COMPUTER
ENGINEERING (ELECTRICAL POWER ENGINEERING)**

By

Abiyot Mekonnen

Advisor:- Prof –WoledeGiorigs WoldeMariyam



ADDIS ABABA UNIVERSITY

ADDIS ABABA INSTITUTE OF TECHNOLOGY

Department of Electrical and Computer Engineering

**Feasibility Study of Renewable Energy Resources
for Electrifications of Small Islands.**

A Case Study on TanaLake Islands

By

Abiyot Mekonnen

GSR/3203/03

APPROVAL BY BOARD OF EXAMINERS

CHAIRMAN DEPARTMENT OF
GRADUATE COMMITTEE

SIGNATURE

ADVISOR

SIGNATURE

INTERNAL EXAMINER

SIGNATURE

EXTERNAL EXAMINER

SIGNATURE

Declaration

I, the undersigned, declare that this thesis is my original work, has not been presented for a degree in this or any other university, and all sources of materials used for the thesis have been acknowledged.

All examiners' comments are incorporated.

Name: Abiyot Mekonnen W/Giorgis

Signature: _____

Place: Addis Ababa

Date of submission: _____

This thesis has been submitted for examination with my approval as a university advisor.

Prof –WoledeGiorigsWoldeMariyam

Advisor's Name

Signature

Dedication

... to my beloved brother

Ato Aschalew Mekonnen

and

to my Wife

Yimenyushal Merha (B.Sc.)

... for their incomparable support in all of my academic achievements!

!

Acknowledgement

First of all I would like to thank Almighty God for His willingness without which this thesis work is impossible. In addition I would like to thank AAiT (Addis Ababa Institute of Technology) for facilitating the thesis work.

I will take this chance to thank my advisor Prof –Woledegiorigs WoldeMariyam for his indispensable, guidance and supervision of this thesis work from the motivation up to end of paper. He was very friendly and he always advise me on the way of thinking every challenge has its own solution.

All in all, I found **Prof –Woledegiorigs WoldeMariyam** not only as an academic advisor but also as good father. I have also well thanks to **Dr GetachewBekele** for his guidance on how to do thesis and how to use Homer soft ware

I want to acknowledge the, National Metrological Agency and officials of Baherdarzuriyawerda and Tana Lake port organization for their cooperation to provide the raw data. My special thanks go to my brother and my wife for their significant support.

Abiyot Mekonnen

Abstract:

The energy problem of islands differs from those in mainland countries because islands need to manage their own energy supplies. The islands are good test beds for the utilization of renewable energy production and storage technologies. The present study relates the main renewable energy resources to the electrical production in the small islands in Lake Tana. The necessity to integrate some renewable energy resources is shown and various storage means are classified. Also, the needs for hydro pumping storage are proposed and investigated as a good solution for promoting to the increase of the penetration rate of renewable energies, particularly in island electrical grid interconnections.

In Ethiopia there are two lakes which have Islands (Lake Tana and Lake Zeway). Among them, the island on Lake Tana (Deck Island) is the biggest Island in the country having a total population of about 7000 human residents within five villages. Due to the location of the Island is so far the task of their electrification via grid system very difficult. Kerosene is used for lighting; with diesel power generation is for milling and pumping, leaving biomass for cooking and dry cells for radio which are being used in this Island. Nothing has been done so far in developing the renewable energy resources, such as small-scale hydro, solar, and wind energy in the Island. In this work, feasibility of renewable energy resources for electric supply system to this small Island is studied using HOMER (Hybrid Optimization Model for Electrical Renewables) software as optimization and sensitivity analysis tool. Meteorological data from National Meteorological Agency of Ethiopia and other sources, such as NASA, have been used for the estimation of solar and wind energy potentials. Electric load for the basic needs of the community, such as, for lighting, radio, television, electric baker, water pumps and flour mills, have been estimated. Primary schools and health posts are also considered as energy users for the community. As a result, based on the storage system, PV/Wind/pumped hydro hybrid system combinations is found as having a cost of energy about \$0.151/kWh which is much lower than diesel generators and previously studied PV-battery hybrid systems which is estimated to cost about \$0.325/KWh

Key words: Wind, Solar, Hybrid, HOMER, Pumped hydro, Load Estimation

Table of Contents

Declaration.....	i
Dedication.....	ii
Acknowledgement.....	iii
Abstract.....	iv
List of Figures.....	viii
List of Tables.....	x
Nomenclature.....	xi
CHAPTER 1.	
1.Introduction.....	1
1.1 Background and Statement of the Problem.....	1
1.2 Objectives of the study.....	3
1.3 Methodology.....	3
<i>Site Identification.....</i>	<i>3</i>
<i>Data Collection and Literature Survey.....</i>	<i>4</i>
<i>Data Analysis and Feasibility Study.....</i>	<i>4</i>
1.4 Organization of the thesis.....	4
CHAPTER 2	
2. Solar PV System and Solar Potential in Ethiopia.....	5
2.1. Status of solar PV power Generation in Ethiopia.....	5
2.2. Potential of solar Energy.....	5
2.3. PV Systems.....	5
2.4. Structure of storage system.....	6
2.5. Electrical equivalent circuit of PV cell.....	7
2.6. Conversion Efficiency of solar cell.....	10

2.7. PV module performance rating.....	12
2.8. Solar radiation Estimation	13
2.9. Solar energy Assessment of Deck Island	17
CHAPTER 3:	
3 Hydro power plant and its potential in Ethiopia.....	19
3.1. How hydropower works	20
3.2. Types of Hydro power plant.....	20
3.3. Classifications of Hydropower plant.....	21
3.4. Small Hydro power System Desig.....	21
3.5. Component of small hydro power.....	25
3.6. Cause of failure	27
3.7. Pumped storage Hydropower system.....	27
3.8. Designed Micro hydro using pumped storage system	29
CHAPTER 4	
4. Wind Powe and Wind Resourcess in Ethiopia.....	31
4.1. Wind Power Generation.....	31
4.2. Wind Energy Resources	31
4.3. Wind Speed Measurements.....	32
4.4. Wind Power.....	32
4.5. Wind Energy Conversion System.....	34
4.6. Wind Energy Estimation of Deck Island.....	35
CHAPTER 5	
5. Hybrid System Optimization using HOMER.....	39
5.1. Introduction.....	39

5.2. Basic Components and Model of Hybrid System.....	40
5.3. Simulation using HOMER.....	44
5.4. Load Estimation.....	46
a) Primary Load Estimation	46
b) Deferrable load Estimation.....	51
5.5. Summary of Input Data to HOMER.....	56
CHAPTER 6	
6. Simulation Results, Conclusions and Recommendations	
6. Introduction.....	64
6.1. Results In Case of Battery Storage.....	65
6.2. Results In Case of Pumped storage.....	67
6.3. Conclusions.....	71
6.4. Recommendations.....	72
6.5. Suggestions for Future Works.....	73
References.....	74
Appendix A.....	77
Appendix B.....	79

List of Figures

Figure 1-1 Map of Lake Tana	2
Figure 1-2 Map of Deck Island	3
Figure 2-1 PV cel, module and array of PV systeml [7]	6
Figure 2-2Componenet of PV storge system[7].....	6
Figure 2-3Mounting rack	7
Figure 2-4 Equivalent circuit of PV cell [8].....	7
Figure 2-5 Charcterstics curve of PV module [9]	9
Figure 2-6The I-V characterstics of PV cell [11]	9
Figure 2-7Effect of insulation on module performane [12]	10
Figure 2-8Effect of cell temprature on panel performance [10].....	11
Figure 2-9Sun earth relation ship [25].....	13
Figure 2-10 Geometry of Solar cell and aloction of Sun relative to earth [26].....	14
Figure 3-1 Example of a Diversion Hydropower Plant [20]	20
Figure 3-2Water flow Cubic feet per second [20]	22
Figure 3-3Flow rate measuring procedure	23
Figure 3-4 Head measuring techniques of small hyro power [21].....	24
Figure 3-5Reaction Turbine [22]	26
Figure 3-6Impulse turbine [22]	26
Figure 3-7Schematic Pumped storage with one reversable pump [24].....	28
Figure 3-8 Pumped storage systemwith wind turbine [23].....	29
Figure 3-9 Over all system pumped storge hydro system	29
Figure 3-10 Avilable head on Deck Island	30
Figure 4-1An air parcelmoving towards wind turbine	34
Figure 4-2 Block diagram of wind energy conversion system	34
Figure 5-1 General Scheme of small Hydro/PV/Wind hybrid system	41
Figure 5-2 Acceptable battery cell voltage [35].....	43
Figure 5-3 Lead -Acid battery discharge rate [35]	44

Figure 5-4 Monstries on Deck Islands	47
Figure 5-5 Solar Panel of Deck Island Health center.	48
Figure 5-6 Deck Primary School	49
Figure 5-7 Diesel flour milling of the Island	50
Figure 5-8 Avilable head of Deck island	52
Figure 5-9 Hand driven water pump in deck Island	54
Figure 5-10 Diesel motor based irregated land on isalnd	56
Figure 5-11 Power curve of FL100 wind Turbine	57
Figure 5-12 Wind speed in Deck Island	57
Figure 5-13 Monthly Solar radtion of the Deck Island	57
Figure 5-14 Desiel generator Effieency Curve	58
Figure 5-15 Designed flow rate of pumped storage system	59
Figure 5-16 Primary Load of Deck Island	60
Figure 5-17 Defferable Load of Deck Island	60
Figure 5-18 Wind/PV/Diesel/Battery hybrid system.....	61
Figure 5-19 Wind/PV/Diesel/pumped hydro hybrid system	62
Figure 6-1 Cash flow summary in case of Battery storage system	65
Figure 6-2 Monthly Average Electric production in case of Battery storage system.....	66
Figure 6-3 Cash flow summary in case of pumped storage system.....	68
Figure 6-4 Monthly average electric production in case of pumped storge system	69
Figure 6-5 Sensitivity results for PV module Vs Wind speed	70

Table-2-1: Monthly Solar radiation at Deck Islandl	17
Table 3-1 Regional estimation of small hyro power potential [32]	20
Table 3-2 Required water flow and head for small hydroelctric	25
Table 4-1 Friction Coefficent of various terrians [17].....	33
Table 4-2 Generator power of the turbine at specfic wind speed	37
Table 4-3 Avilable Wind energy in each month of project site.....	38
Table 5-1 Load of Home appliances	47
Table 5-2 Load of Historical Monastries	48
Table 5-3 Load of health center	49
Table 5-4 Load of primary school.....	49
Table 5-5 Load of high school	50
Table 5-6 Summary of primary load in Deck Island	51
Table 5-7Daily irrigation indicator	55
Table 5-8 Monthly deffrable load	56
Table 5-9 Size and cost description of of wind/PV/Diesel/battery storage system.....	61
Table 5-10 Size and cost description of wind/PV/Diesel/pumped storage system	63
Table 6-1 Optimazation result in catagorized form for battery storage system	66
Table 6-2 Extract from over all optimum result	66
Table 6-3 System report for 95%renewable friction for Case -1.....	68
Table 6-4 optimum result in case of Pumped storage sytem	68
Table 6-5 System report for 95% renewable friction for case II	69

Nomenclature

a	regression coefficient
A	the diode quality/curve fitting factor
A	the swept area of wind turbine (m^2)
A_c	the array area
b	regression coefficients
c	A scale parameter of Weibull distribution (m/s)
CC	Cyclic charge dispatch strategy
CFL	Compact fluorescent lamp
COE	Cost of energy (\$/kWh)
C_p	the power coefficient of wind turbines
EEPCo	Ethiopian Electric Power Corporation
E_g	Band gap energy
ESRI	Environmental Systems Research Institute
$f(v)$	Weibull probability density function of wind distribution
f	system frequency
g	gravitational acceleration ($9.81 m/s^2$)
G_{sc}	The solar constant =1367 (W/m^2)
G_0	extraterrestrial irradiance at any angle of incidence
G_{on}	extraterrestrial irradiance at normal incidence
GDP	Gross Domestic Product

GIS	Geographical Information System
G_T	the incident solar radiation on the array
H	monthly average daily radiation on horizontal surface (MJ/m ²)
H_{eff}	effective head (m)
H_0	monthly average daily extraterrestrial radiation on a horizontal surface (MJ/m ²)
HOMER	Hybrid Optimization and Modeling of Electrical Renewables
I	the load current (A)
I_0	reverse saturation current of the diode (A)
I_a	armature current (A)
I_D	the diode current (A)
I_L	current produced by the cell (A)
I_{mp}	maximum power current (A)
I_{mpp}	Current at maximum power point
$I_{sc}(G)$	the short circuit current at radiation level G (A)
I_{sh}	current through the shunt resistance (A)
k	A constant known as shape factor of Weibull distribution
K	Boltzmann's gas Constant
LF	Load follow dispatch strategy
MPP	Maximum power point
N	the maximum possible daily hours of bright sunshine given by equation

n	monthly average daily number of hours of bright sunshine
NASA	National Aeronautics and Space Administration
NOCT	Normal operating Cell temperature
NPC	Net present cost
n_s	synchronous speed
P_h	hydropower output in kilowatts (kW)
P_{outs}	output power of synchronous generator (kW)
P_w	power in the wind (W)
P_{wout}	output power of wind turbine (W)
PDF	Probability Density Function of wind distribution
P_{mp}	maximum power point (W)
P_{pole}	number of pole pairs
P_{pv}	power output of PV array
$prob(v \geq V)$	Probability of instantaneous wind speed is greater than V
$prob(v \leq V)$	Probability of instantaneous wind speed is less than V
PV	Photo Voltaic
Q	charge on an electron(C)
Q_h	quantity of water flow rate (m^3/s)
Q_{gauge}	River flow rate at the gauge station (m^3/s)
Q_{site}	River flow rate at the study point (m^3/s)
R_a	winding/armature resistance (Ω)

SWERA	Solar and Wind Energy Resource Assessment
t_L	local solar time in hours.
$V(z)$	Wind velocity at height of Z m above ground (m/s)
V	instantaneous wind velocity
V	output voltage of PV cell (V)
V_a	output terminal voltage (V)
V_{mp}	maximum power voltage (V)
V_{Mpp}	Voltage at maximum power point
V_{oc}	open circuit voltage (V)
$v(z)$	wind speed at height of Z m (m/s)
$v(z_r)$	wind speed at the reference height (m/s)
\bar{v}	mean wind speed
X_a	winding/synchronous reactance
Z	height where wind speed is to be determined (m)
Z_0	Surface Roughness length (m)
Z_r	reference height (m)
δ	declination angle ($^{\circ}$)
η_e	the efficiency of power conditioning equipment ($\approx 90\%$)
η_{mp}	the maximum power point efficiency of the array ($\approx 14\%$)
ω_s	The sunset hour angle

α_s	solar altitude ($^{\circ}$)
γ_s	solar azimuth ($^{\circ}$)
θ_z	zenith angle ($^{\circ}$)
θ_i	The angle between the solar beam and normal to the solar panel
Φ	the angle between the voltage V_a and the current I_a
ρ	Density of air
ϕ	Latitude ($^{\circ}$)
η	Turbo-generator efficiency
η_t	Overall efficiency of the transmission system/power train of wind turbine
ω	Solar hour angle ($^{\circ}$)

CHAPTER 1

Introduction

1.1 Back ground and Statement of the problem

Ethiopia is located in the eastern part of Africa between 3° to 15° north and 33° to 48° east. With a surface area of 1.1 million square kilometers; it is the third largest country in Africa. It is the second most populous country in Sub Saharan Africa with an estimated population of about 80 million, which is mostly distributed in northern, central and southwestern high lands [1]. Ethiopian economy is predominantly based on agriculture which contributes the lion's share of about 50% to the GDP and over 80% of employment. The agriculture sector is the leading source of foreign exchange for Ethiopia. Coffee distantly followed by hides and skins, oilseeds and recently cut-flower are the major agricultural export commodities. At present the per capita income in Ethiopia is less than USD 200. With only 6% of households connected and 15% of the population having access to electricity in 2007 [2] from Ethiopian Electric Power Corporation (EEPCo), access to electricity in Ethiopia is one of the lowest by any standards. Despite the fact that 80% of the population of Ethiopia live in rural areas, electricity supply from the grid is almost entirely concentrated in urban areas. Among other things, dispersed demand and very low consumption level of electricity among rural consumers, limited grid electricity penetration to rural population to less than 1%. Based on the hitherto electricity expansion practices in the country, access to electricity does not seem to be the reality of the near future for the greater percentage of the rural population. The UEAP(Universal Electricity Access Program)does not only aim to increase access, but also aims to raise the level of national per capita consumption of electricity from the current 28 kWh to 128 kWh by the year 2015. In order to realize this, the dependable capacity of the power plants has to be increased to 10GW from the current 2GW. The Government of Ethiopia is aware of the fact that the national utility alone through continuous grid extension cannot accelerate rural access to electricity. In the struggle to improve rural access to electricity, the government has recently streamlined its strategies and embarked upon removal of barriers and constraints to accelerated off-grid rural electrification. The Rural Electrification Strategy provides opportunities for an increasing participation of the private sector in the supply of electricity to un-electrified rural population. This has included the design of institutional and financing framework for private sector-led rural electrification, which are expected to remove barriers and facilitate private sector participation in the provision of off-grid

electricity supply (generation, transmission, distribution and marketing)[3]. In other way tourism in Ethiopia accounted for 7.5% of the country's gross domestic product (GDP) in 2008, having barely increased over the previous year. The government is proving its commitment and willingness to develop tourism through a number of initiatives. Tourism is a featured component of Ethiopia's Poverty Reduction Strategy Paper (PRSP) that aims to combat poverty and encourage economic development. From popular tourism places of Ethiopia Islands on Tana Lake are one. This thesis work in addition to create access of electricity to the people on island it is also creates a good opportunity for Privat Investment and tourism development of the country.

Lake Tana is the largest lake in Ethiopia located in Amhara region in the North-Western Ethiopian high lands. The lake is approximately 84kilometer long and 66kilometer wide with a maximum depth of 15meter and an elevation of 1840meter. There are 37 islands on Lake Tana from them 19 islands had churches (monsters).



Fig 1.1 Map of Lake Tana in Ethiopia (from Tana lake port organization)

Dek Island is the largest of the 37 islands on Lake Tana covering a land area of 3263 hectare (32.63 Km²) and circumference of 2790.06 m. It is located nearly at the center of the lake, 44 Km (North) away from the regional city Bahir Dar (after a 4 hour travel by boat). According to 2010 Annual Statistical Report from Bahir Dar zuriaworeda administration, there are 7000

peoples in five different Villages. There are 725 households on these Villages who are registered and paid their annual taxes.



Fig 1.2 Map of Dek Island on Tana lake of Ethiopia (from tana lake port organization)

1.2 Objectives of the study

The thesis work has one main and five specific objectives as indicated below

Main objective

- The main objective of this thesis is feasibility study of renewable energy resources for electrification of small islands. As case study on Tana Islands.

Specific Objectives

- Estimation of the solar radiation potential
- Estimation of the wind power generation potential
- Determining of appropriate storage system for possible hybrid system
- Modeling a community load system
- Optimization and sensitivity analysis of the possible hybrid system

Serious attempts have been made include qualitative and quantitative assessment of energy needs for the growing population in the Lake Tana Islands

1.3. Methodology

The methodology followed in the study consists of Site identifications, Data collection and Survey, as well as Data analysis and feasibility study.

Site Identification

Solar and wind distribution are assumed to be same throughout the lake. The lake is located at (located at 12.0⁰N and 38° 3'3.00"E):

Data Collection and Literature Survey

Relevant data is collected from three main sources. The first is from organizations and agencies like National Meteorological Agency, Energy office of the Amhara region and Tana lake port organization. Sunshine hour, wind speed and direction and brief history of the lake and the islands are collected from these offices and agencies. The second source is the sites themselves. Geographical layout, population distribution, surrounding environment in relation to the system design, deferrable and primary loads of the island and geological characteristics are collected by visiting the sites. The third one is from different websites, especially related to cost of PV modules, wind turbines, diesel generator, converter and battery. Related literatures on island electrification as abroad are considered. These include papers and books related to rural load estimation, potential assessment techniques of wind, solar resources, and pumped storage system for optimization of hybrid system components.

Data Analysis and Feasibility Study

The head of pumped storage system is taken by physical measurement. The wind speed data is taken from NASA. The solar radiation is estimated from sunshine duration data taken from National Metrological Agency. These data are prepared in suitable format for input to HOMER. Then, feasibility study of wind and solar with pumped hydro as storage systems is studied.

1.4. Organization of the Thesis

The thesis work start with an introductory back ground followed by basic theory of Solar PV systems and their potentials .The introduction part discusses about the background, statement of the problem, objectives, publication and related works to this thesis. Chapter one covers the basic theory of solar PV system and the potential at Deck island. Chapter two and chapter three present the basic theories of hydro and wind systems together with their potential estimations at Deck Island respectively. Chapter four discusses the application of HOMER for PV/wind/pumped hydro and PV/wind/battery hybrid system, whereas, chapter five is all about the results of optimization and sensitivity analysis of the system. Chapter six summarises the main findings of the thesis work. Appendix A presents the full length overall optimization results for two cases.

HAPTER 2

2. Solar PV System and Solar Potential in Ethiopia

2.1 Status of Solar Photovoltaic Power Generation in Ethiopia

It is estimated that about 1200 kWp PV capacity in about five to six thousands unit are operational in Ethiopia [4]. This is far too low compared to even too low income sub Saharan countries (Tanzania, Burundi, Rwanda, Uganda, and Kenya). As many of these countries are much smaller in area and population computed to Ethiopia, the per-capital renewable energy installed capacity in Ethiopia is probably the least in Africa. For instance, in Rwanda in 1993 the installed capacity of PV lighting systems was about 29 kWp (Karekezi and Ranja, 1997) and the per capital installed capacity was 4.1Wp/1000 people in 1993 compared to 1.5 Wp/10000 people in 2001 for Ethiopia. This is unfortunate considering of the fact that Ethiopia has a largesolar energy resource. Application and technology wise, the available information indicates that PV systems of about 850 kWp are being used by the ETC mainly to power repeater and radios in remote areas. PV systems employed for water pumping, refrigeration, school lighting, radios, and home lighting may not exceed 100kWp. As in the case of most developing courtiers, in Ethiopia, PV for water pumping and rural clinics were the main areas of focus, ‘Mito’ large scale pilot PV systems with 31.5 kWpwhich was operated by EREDPC [4].

2.2 Potential of Solar Energy

Studies indicate that for Ethiopia as a whole, the yearly average daily radiation reaching the ground is 5.26 kWh/m². This varies significantly during the year, ranging from a minimum of 4.55 kWh/m² in July to a maximum of 6.55 kWh/m² in February and March. On regional basis, the yearly average radiation ranges from values as low as 4.25 kWh/m² in the areas of Itang in the Gambella regional state (western Ethiopia), to values as high as 6.25 kWh/m² around Adigrat in the Tigray regional state (northern Ethiopia) and in Afar and Somali Region of Eastern Ethiopia.[2,5]

2.3 PV Systems

A photovoltaic (PV) or solar cell is the basic building block of a PV (or solar electric) system. An individual PV cell is usually quite small, typically producing about 1 or 2 watts of power. To boost the power output of PV cells, we connect them together to form larger units called modules. Modules, in turn, can be connected to form even larger units called arrays, as shown in Figure2.1 which can be interconnected to produce more power, and so on. In this way, we can build PV systems able to meet almost any electric power need, whether small or large [6].

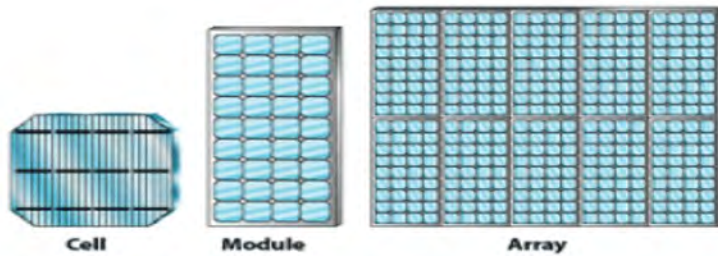

Fig 2.1 PV cell, module, and array of a PV system [6]

2.4 The Structure of PV Storage System

As shown in figure 2.2 the PV system consist from the main components: PV array, controller (Charge Regulator), batteries, inverter and DC load or AC load or both

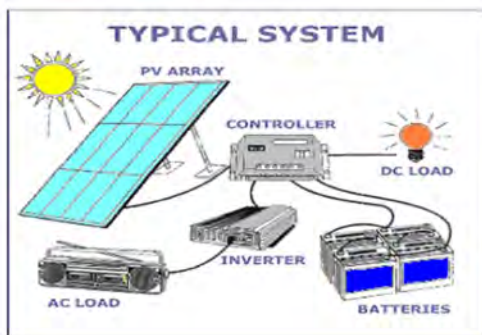

Fig2.2 Components of PV storage system [7]

Mounting structures

Photovoltaic arrays must be mounted on a stable, durable structure that can support the array and withstand wind, rain, hail, and other adverse conditions. Sometimes, this mounting structure is designed to track the sun. However, stationary structures are usually used with flat-plate systems. These structures tilt the PV array at a fixed angle (tilt angle, the angle between the sun irradiation rays and the vertical lines, or between the plane of the PV array and the horizon) determined by the latitude of the site, the requirements of the load, and the availability of sunlight, as shown in Figure 2.3

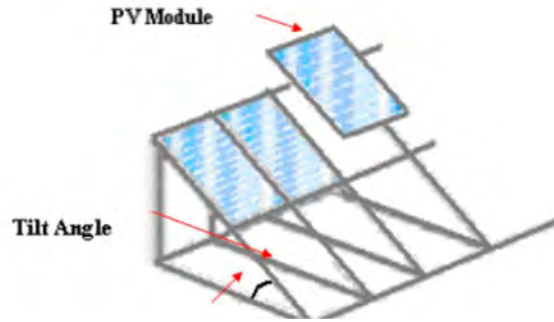

Fig2.3 mounting rack[6]

2.5 The Electrical Equivalent Circuit for PV cell

The equivalent circuit of a photovoltaic cell is shown in figure 2.4. The current source represents the photocurrent (I_L), generated at the junction region by the photons with energy enough to produce pairs of electrons-holes; the diode represents the PN junction with reverse saturation current (I_0); Joule losses and leakage currents are represented by the currents through the series resistance (R_S) and the shunt resistance (R_P) respectively [7].

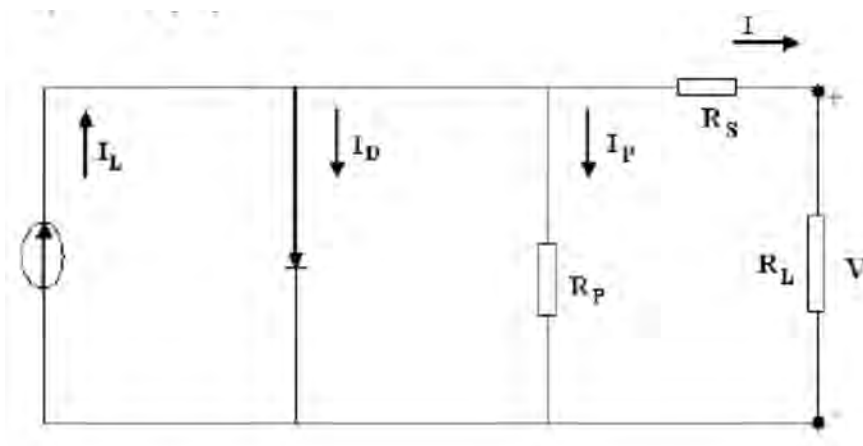

Fig2.4 Equivalent circuit of a photovoltaic cell [7]

When the first Kirchhoff law is applied to one of the nodes of the equivalent circuit, the current supplied by a cell, at a specified temperature, is given by:

$$I = I_L - I_D - I_P = I_L - I_0 \left\{ \exp\left(\frac{q(V + IR_S)}{NAkT} - 1\right) \right\} - \frac{V + IR_S}{R_p} \quad 2.1$$

Where; I is the output current. I_L is the photo current. I_D is the diode current. I_p is the leakage current flowing in the shunt resistance, which it's very small and can be Negligible. I_o is the reverse saturation current. N is the number of cells associated in series. A is the diode ideality factor, which lies between 1 and 2 for mono crystalline silicon. K_B is the Boltzman constant = $1.38 \times 10^{-23} \text{ J/K}$. T_{cell} is the absolute cell temperature in Kelvin (K°). q is the electronic charge = $1.602 \times 10^{-19} \text{ C}$. V is the terminal voltage. If an association of cells (photovoltaic modules) the case, N is the number of cells associated in series. Most of the photovoltaic modules available in the market are constituted by 36, and 40 cells [8].

Three points of the curve in the Fig (2.5) should be highlighted:

a) Open-circuit: this point is obtained when the terminals of the module are disconnected. The module presents a voltage called (VOC). Expressed analytically using the following expression:

$$V_{OC} = \frac{AK_B T_{cell}}{q} \ln \left[\frac{I_L}{I_o} \right] \quad I_L \gg I_o \quad 2.2$$

b) Short-circuit: the terminals of the module are connected with an ideal conductor, through which flows a current called (ISC). In this situation, the voltage between module terminals is zero.

$$I_{SC} = I_L = KG \quad 2.3$$

Where K is constant and G is the irradiance (W/m^2)

c) MPP where the voltage versus current product is maximum. $VMPP$ is related to VOC through the relation [10]:

$$VMPP \approx 0.8 * Voc \quad 2.4$$

And $IMPP$ is related to ISC through the relation [9] :

$$IMPP \approx 0.9 * ISC \quad 2.5$$

The relations shown in the above two equation can be used to approximate the maximum power point coordinates in terms of voltage and current for different working meteorological conditions. The best conditions are the "standard operating conditions" happen at Irradiance equal to 1000 W/m^2 , cells temperature equals to 25°C , and spectral distribution (Air Mass) AM is equal to 1.5. Nevertheless, while in operation the modules are normally not under standard condition. So another condition was defined, named "normal operation condition", which presents the following values:

Irradiance = 800 W/m² . Ambient temperature = 20 °C . Wind speed = 1 m/s , and Spectral distribution = AM 1.5 Figure 2.5 shows a generic characteristic curve. It can be observed that, from the short circuit, the current presents a slightly descending behavior until it reaches to an "elbow" from where it decreases quickly down to zero.

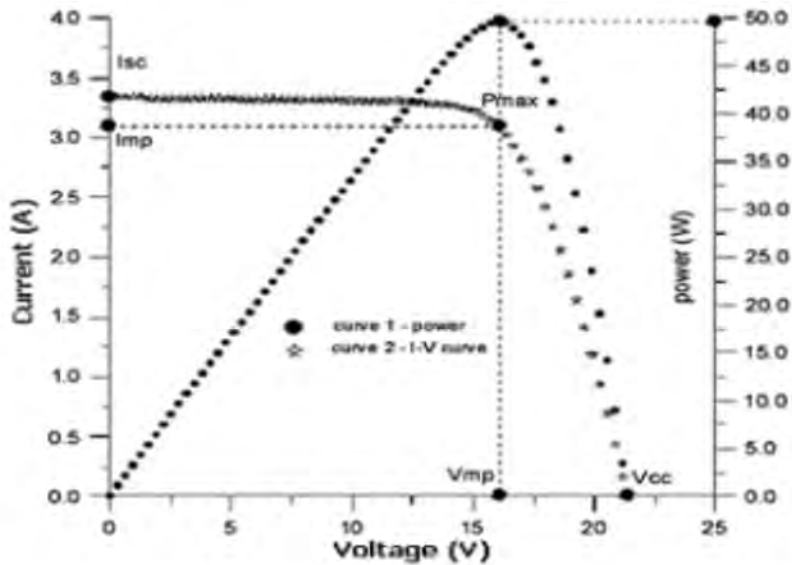

Fig 2.5 Characteristic curve of a photovoltaic module [8]

2.6 The conversion efficiency of a solar cell

The percentage of the solar energy shining on a PV device that is converted into electrical energy, or electricity. The efficiency of solar cells depends mainly on the following factors:

a) The effect of the intensity of sunlight:

A cell's or module's (consisting of 36 mono crystalline silicon cells) current output is proportional to the intensity of solar radiation to which it is exposed. More intense sunlight will result in greater module output, as illustrated in Figure 2.7 .As the sunlight level drops, the shape of the IV curve remains the same, but it shifts downward indicating lower current output. Voltage (of module is equal to 36 cells voltage of mono crystalline silicon = $36 * 0.6 = 21.6$ V) is approximately not changed.

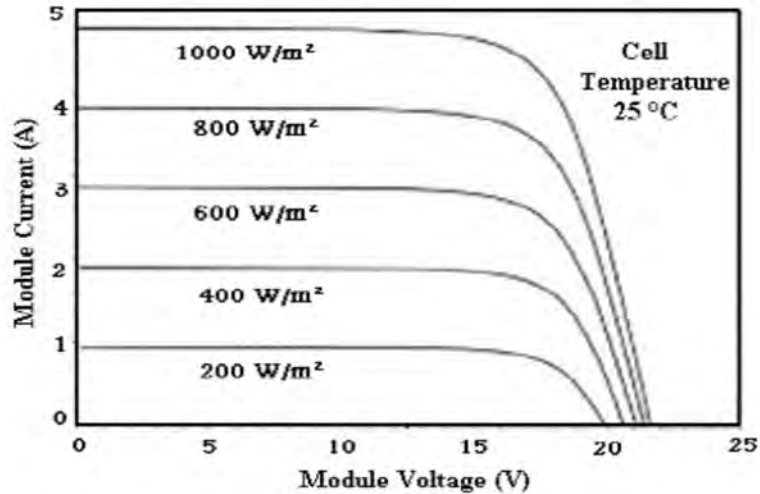

Fig 2.7 Effect of insulation on module performance [10]

The effect of changing the irradiance level on the behavior of the solar cell can be found by finding the effect on the open-circuit voltage and the short circuit current. For a constant cell temperature of 25 °C. It is clear that the short circuit current is linearly proportional to the irradiance level. If irradiation changes from G_1 to G_2 , then the new short circuit current is found according to the following equation:

$$\frac{I_{sc2}}{I_{sc1}} = \frac{G_2}{G_1} \quad 2.6$$

b) The effect of cell temperature

As the cell temperature rises above the standard operating temperature of 25°C .The module of 36 cells operates with less efficiency and the voltage decreases as shown in figure 2.8

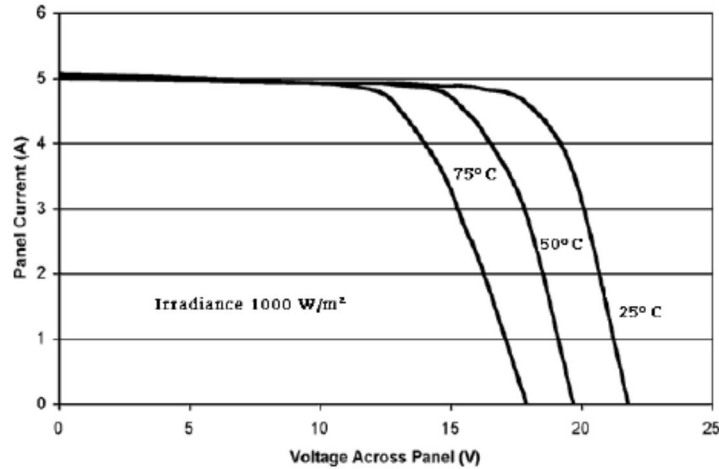

Fig 2.8 The effect of cell Temp. On panel performance [10]

Solar cells work best at low temperatures, as determined by their material properties. All cell materials lose efficiency as the operating temperature rises. Much of the light energy shining on cells becomes heat. It's also clear, that increasing the cell temperature increases the photocurrent slightly. This increase is in the range of 0.1 % / 1°C [10] and it's arises from a decrease in the band-gap energy of the material as the temperature increases. If the temperature changes from T1 to T2, then the short circuit current changes according to the equation [10]:

$$I_{sc2} = I_{sc1}[1 + \alpha(T2 - T1)] \quad 2.7$$

Where α can be described as the current coefficient with respect to temperature change and is equal to $(0.1 / (100 * I_{sc1}))$. On the other hand, the open-circuit voltage would decrease linearly with increasing cell temperature owing to the exponential increase in saturation current (I_0). I_0 is a current of minority carriers created by thermal excitation. It's variation with temperature can be expressed as [10]

$$I_0 = A_0 T^3 \exp\left(-\frac{E_g}{K_B T}\right) \quad 2.8$$

Where E_g is the band-gap energy, K_B is the Boltzmann's gas constant, and A_0 is the diode ideality factor. The change in the open-circuit voltage from a change in temperature from T1 to T2 can be expressed in the following form:

$$V_{oc2} = V_{oc1}[1 + \beta (T_2 - T_1)] \quad 2.9$$

Where β can be described as the voltage coefficient with respect to temperature change and is equal to about (- 0.004) [10].

2.8 Solar radiation estimation

The Sun

The sun is a sphere of intensely hot gaseous matter with a diameter of 1.39×10^9 m and is, on the average, 1.5×10^{11} m from the earth. As seen from the earth, the sun rotates on its axis about once every 4 weeks. However, it does not rotate as a solid body; the equator takes about 27 days and the Polar Regions take about 30 days for each rotation. The sun has an effective blackbody temperature of 5777 K. The temperature in the central interior regions is variously estimated at 8×10^6 to 40×10^6 K and the density is estimated to be about 100 times that of water. The sun is, in effect, a continuous fusion reactor with its constituent gases as the “containing vessel” retained by gravitational forces. Several fusion reactions have been suggested to supply the energy radiated by the sun. The one considered the most important is a process in which hydrogen (i.e., four protons) combines to form helium (i.e., one helium nucleus); the mass of the helium nucleus is less than that of the four protons, mass having been lost in the reaction and converted to energy.[11]

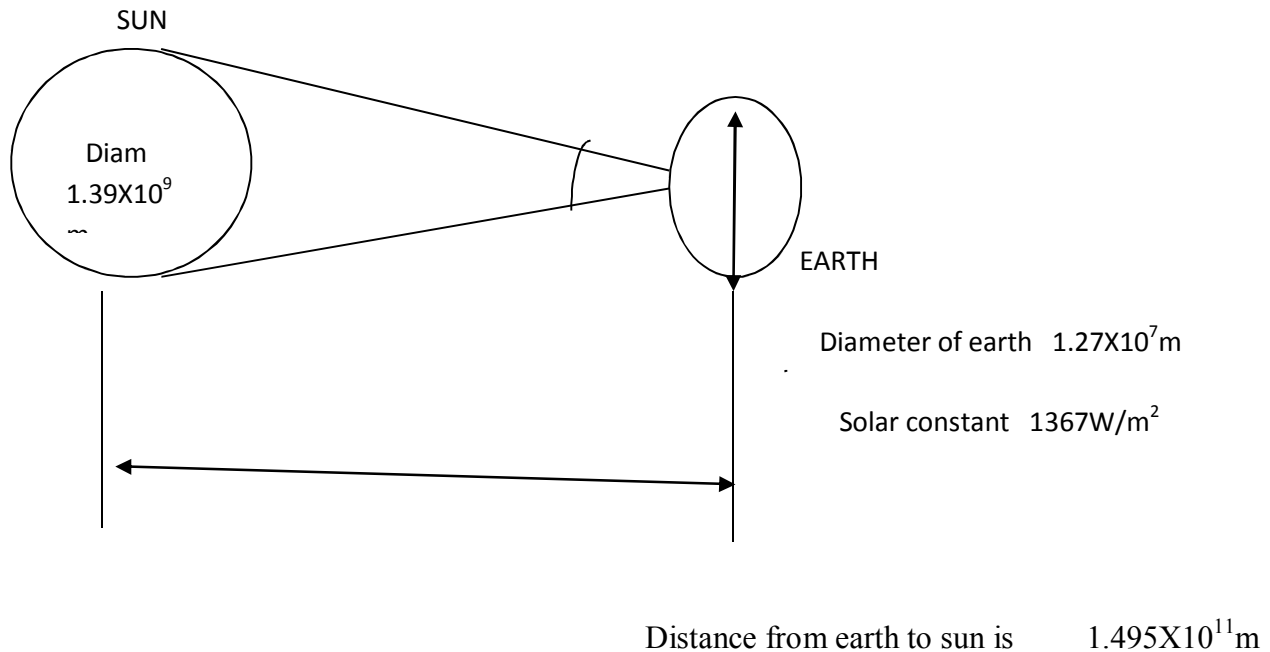

Fig 2.9 sun earth relationships [10]

For any solar based system design, the most important factors are the position of the sun in the sky, the slope and orientation of a collecting surface, and obstruction and reflection properties of neighbouring structures. Figure 2.10 shows the geometry describing orientation of a collector and position of the sun in the sky.

A point on the earth's surface is expressed by its latitude and longitude. The angle between the collector surface and the horizontal is called slope, β (with $0^\circ < \beta < 90^\circ$ for a surface facing towards the equator; $90^\circ < \beta < 180^\circ$ for a surface facing away from the equator). Surface azimuth angle, γ is the angle between the normal to the surface and the local longitude meridian, projected on the horizontal plane. In either hemisphere, γ equals 0° for a surface facing due south, 180° due north, 0° to 180° for a surface facing westward and 0° to -80° eastward. For a horizontal surface, γ is always 0° .

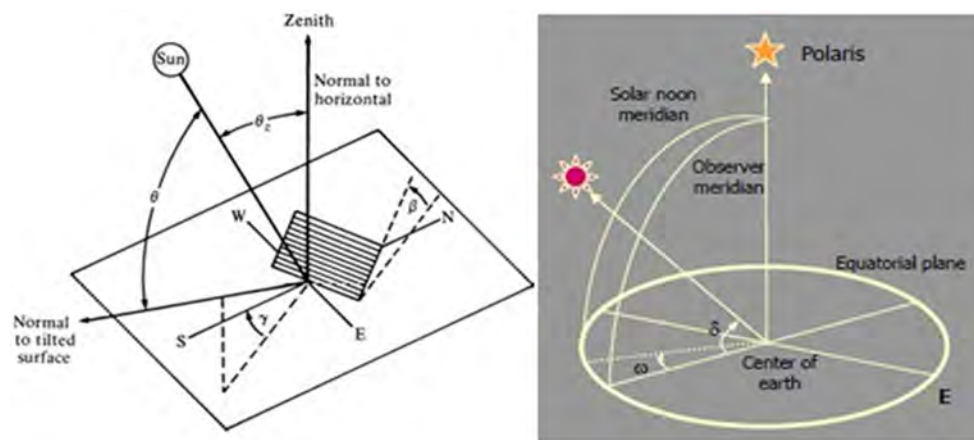

Figure 2.10 Geometry of solar collector and location of sun relative to earth [12]

Location of the sun in the sky, relative to a point on the ground, can be defined in terms of two angles, the solar altitude, α_s (or its complement the solar zenith angle, θ_z) and the solar azimuth γ_s . Solar altitude, α_s , angle of solar beam to the horizontal. Solar azimuth, γ_s , is the angle between the solar beam and the longitude meridian projected on the horizontal plane. Sign convention is the same as for surface azimuth angle (γ). Solar altitude and solar azimuth are functions of location (latitude, ϕ), time of the year (declination angle, δ) and time of the day (hour angle, ω). Solar declination angle (δ) is the angle

between the earth's equatorial plane and the earth sun line. Solar hour angle ω is the angle Earth has rotated since solar noon. The relation between these angles is given below [3, 25,27- 29].

$$\delta = 23.45 \sin\left(360 \frac{284 + n_d}{365}\right) \quad (2.11)$$

where δ =solar declination angle ($^{\circ}$)

n_d =day number of the year starting at January 1st as 1

$$\omega=(12-t_L)15^{\circ} \quad (2.12)$$

where t_L =local solar time in hours.

ω =solar hour angle ($^{\circ}$)

$$\sin(\alpha_s)=\sin(\phi)\sin(\delta)+\cos(\phi)\cos(\delta)\cos(\omega) \quad (2.13)$$

where: α_s = solar altitude ($^{\circ}$)

ϕ =latitude ($^{\circ}$)

$$\sin(\gamma_s)=\frac{\cos(\delta)\sin(\omega)}{\cos(\alpha_s)} \quad (2.14)$$

where: γ_s = solar azimuth ($^{\circ}$)

The sunset/sunrise angle is given by

$$\omega_s = \cos^{-1}(-\tan \phi \tan \delta) \quad (2.15)$$

The angle of incident θ_i is the angle between the solar beam and normal to the solar panel which is given by:

$$\begin{aligned} \cos(\theta_i) = & \sin(\delta)\sin(\phi)\cos(\beta)-\sin(\delta)\cos(\phi)\sin(\beta)\cos(\gamma) \\ & +\cos(\delta)\cos(\phi)\cos(\beta)\cos(\omega) +\cos(\delta)\sin(\phi)\sin(\beta)\cos(\gamma)\cos(\omega) \quad (2.16) \\ & +\cos(\delta)\sin(\beta)\sin(\gamma)\sin(\omega) \end{aligned}$$

The intensity of solar radiation incident per unit area exposed normally to the sun's rays at the average sun-earth distance (about 1.5×10^{11} m), measured outside the earth's atmosphere is called the solar

constant, $G_{sc}(1367 \text{ W/m}^2)$ [25, 28, 29]. The intensity of radiation received outside the earth's atmosphere varies as the inverse square of the earth-sun distance and can be expressed in relation to time of the year. The extra-terrestrial irradiance on a surface at normal incidence (G_{on}) may be expressed as:

$$G_{on} = G_{sc} \left[1 + 0.033 \cos \frac{2\pi n_d}{365} \right] \quad (2.17)$$

The extraterrestrial irradiance incident on a horizontal plane at an arbitrary angle of incidence is given by,

$$G_o = G_{on} \cos(\theta_z) \quad (2.18)$$

Where θ_z =zenith angle (angle between the sun and the vertical line from a point on earth) which equals to the incident angle of a horizontal surface at the point of interest.

By integrating the solar constant (extraterrestrial irradiance) over the day length gives us the daily solar radiation on the horizontal surface.

$$H_0 = \frac{24 * 3600 * G_{sc}}{\pi} \left(1 + 0.033 * \cos \left(\frac{360 n_d}{365} \right) \right) * \left(\cos \phi \cos \delta \sin \omega_s + \frac{\pi \omega_s}{180} \sin \phi \sin \delta \right) \quad (2.19)$$

where: $n_d \rightarrow$ Day number starting from January 1st as 1,

$G_{sc} \rightarrow 1367 \text{ W/m}^2$, the solar constant,

$\phi \rightarrow$ Latitude of the location (10.25°),

$\delta \rightarrow$ Declination angle ($^\circ$) given by equation 5.

$\omega_s \rightarrow$ Sunset hour angle ($^\circ$)

Ideally, the data required to predict the solar potential of any site are several years of measurements of irradiance on the proposed collector plane. These are rarely available, so the required data have to be estimated from meteorological data available either (i) from the site, or (ii) from some nearby site having similar irradiance, or (iii) from an official solar atlas or database [25]. Here, the sunshine duration data from the nearby station is used to estimate the monthly average solar radiation using the following angstrom type equation [3, 4, 27, and 30].

$$H = H_0(a + b \frac{n}{N}) \quad (2.20)$$

where: $H \rightarrow$ monthly average daily radiation on horizontal surface (MJ/m²)

$H_0 \rightarrow$ monthly average daily extraterrestrial radiation on a horizontal surface (MJ/m²)

$N \rightarrow$ the maximum possible daily hours of bright sunshine given by equation

$n \rightarrow$ monthly average daily number of hours of bright sunshine

a and b are regression coefficients having average value of $a = 0.33$ and $b = 0.43$ [3].

The day length, N , is the maximum possible daily sunshine hour is given by equation 1.14.

$$N = \frac{2}{15} \omega_s \quad (2.21)$$

1.9 Solar Energy Assessment of Deck Island

There is only sunshine duration data recorded at the nearby stations (Bahrdar). By using equations, (2.11 to 2.21), the solar radiation of the district is estimated as shown in Table 1-1. The last column of Table 1-1 shows solar radiation data obtained from NASA in (kWh/m²/day).

Table 2-1 Monthly solar radiation at the project site

Mid of month	n_d	$\delta(^{\circ})$	$\omega_s(^{\circ})$	N (hours)	n	H_0 (kWh/ m ² /d)	n/N	H(kWh/ m ² /d)	NASA
Ja 15	15	-21.3	86.01	11.47	9.90	8.82	0.86	5.87	6.05
Fe 14	45	-13.7	87.53	11.67	10.10	9.53	0.87	6.35	6.78
Ma 15	74	-2.89	89.52	11.94	8.40	10.22	0.70	6.57	6.95
Ap 15	105	9.34	91.75	12.23	8.00	10.54	0.65	6.63	6.62
Ma 15	135	18.74	93.56	12.47	8.10	10.45	0.65	6.56	6.34
Ju 15	166	23.30	94.51	12.60	7.30	10.29	0.58	6.18	5.5
Jul 15	196	21.56	94.14	12.55	5.80	10.32	0.46	5.59	5.43
Au 15	227	13.87	92.60	12.35	4.90	10.44	0.40	5.22	6.11
Se 15	258	2.33	90.47	12.06	7.90	10.30	0.65	6.48	6.09
Oc 15	288	-9.49	88.31	11.78	9.10	9.74	0.77	6.40	6.09
No 15	319	-19.1	86.46	11.53	9.50	8.99	0.82	5.96	5.82
De 15	349	-23.3	85.58	11.41	9.70	8.58	0.85	5.71	6.49
Average								6.13	6.19

For this study the calculated monthly averaged daily radiation summarized in Table 1-1 (9th column) is used

Chapter 3

Hydropower plant and Hydropower Potential in Ethiopia

The water of the oceans and water bodies on land are evaporated by the energy of the sun's heat and come down back to earth surface. Much of the energy of flowing water in a river gets dissipated due to friction encountered with its banks or through loss of energy through internal turbulence. Nevertheless, the energy of water always gets replenished by the solar energy which is responsible for the eternal circulation of the hydrologic cycle. There is another form of water energy that is used for hydropower development: the variation of the ocean water with time due to the moon's pull, which is termed as the tide. Hydropower engineering deals with the two forms of energy and suggests method of converting it into electricity. To make the flowing water do useful work it is necessary to create a head at a point of the stream and to convey the water through the head to the turbines. The national power system is dominated by large hydropower systems. From the total capacity of 30GW to 40GW hydropower potential, only about 2GW is developed and planned to develop about 14GW by end of 2030. All of this generation concentrates on large hydropower plants. Although not developed as such, there is plenty of small hydropower resources in Ethiopia. The average annual potential (exploitable with small slope plants without reservoir) is estimated to be about 20 TWh/year. The electric energy generated from small slope plants, being smaller in capacity and geographically dispersed, is of great importance for rural electrification [31]. Table3.1 summarizes regional distribution of small hydropower potentials.

Table 3.1 Regional estimation of small hydropower potentials [13]

Region	Approximate small hydropower potential
Oromia	35 MW
Amhara	33 MW
Benishangul-Gumuz	12MW
Gambella	2MW
SNNP	18MW

3.2 HOW HYDROPOWER WORKS?

Hydropower converts the energy in flowing water into electricity. The quantity of electricity generated is determined by the volume of water flow and the amount of "head" (the height from turbines in the power plant to the water surface) created by the dam. The greater the flow and head, the more electricity produced. A typical hydropower plant includes a dam, reservoir, penstocks (pipes), a powerhouse and an electrical power substation. The dam stores water and creates the head; penstocks carry water from the reservoir to turbines inside the powerhouse; the water rotates the turbines, which drive generators that produce electricity. The electricity is then transmitted to a substation where transformers increase voltage to allow transmission to homes, businesses and factories.

3.3 TYPES OF HYDRPOWER PLANTS

1. Conventional

Most hydropower plants are conventional in design, meaning they use one-way water flow to generate electricity. There are two categories of conventional plants: a) run-of-river and b): storage plants.

- a) **Run-of-river plants** - These plants use little, if any, stored water to provide water flow through the turbines. Although some plants store a day or weeks' worth of water, weather changes - especially seasonal changes - cause run-of-river plants to experience significant fluctuations in power output.



Fig 3.1 Example of a diversion hydropower plant No dam was required[14]

- b) **Storage plants** - These plants have enough storage capacity to off-set seasonal fluctuations in water flow and provide a constant supply of electricity throughout the year. Large dams can store several years' worth of water.

3.4. Classification of Hydropower Plants

There are a number of criteria for classification of hydropower plants, such as head, flow rate, hydraulic nature, purpose, size and the likes. Although there is no standard classification of hydropower plants, the more widely used classification is summarized below (based on size)

- Large-hydro (> 100 MW feeding into a large electricity grid)
- Medium-hydro (15 - 100 MW usually feeding a grid)
- Small-hydro (1 - 15 MW usually feeding into a grid)
- Mini-hydro (0.1 - 1 MW used either standalone schemes or grid connected)
- Micro-hydro (From 5 - 100 kW used for a small community or rural industry in remote areas far away from the grid.)
- Pico-hydro (< 5 kW used for remote areas far away from the grid.)

Some time, hydropower plants below 15 MW are referred to as small hydro plants [14].

3.5 Small Hydropower system design

One of the first steps in planning is to measure the power potential of the stream. The amount of power that can be obtained from a stream depends on:

- the amount of water flow
- the height which the water falls (head)
- The efficiency of the plant to convert mechanical energy to electrical energy.

a) Measuring Flow

Two methods are commonly suggested for measuring the flow in small or medium sized streams. Large discharges are best determined by a hydraulic engineer. The float method of testing stream flow is the easiest test to conduct and will yield satisfactory data, except in cases where a stream is shallow or rocky and thus impedes the movements of a weighted float. Basically the cross section of an unobstructed area of the stream is measured and a weighted float such as a bottle weighted with pebbles is timed as it floats down a 100 foot course. The weir method is more time consuming but may be the most satisfactory test if the stream is very small, shallow, and rocky, obstructed, or if there is an existing dam. A weir is a dam with an opening or notch through which the entire stream flows. The flow may be calculated by precisely measuring the depth of water flowing over the crest of the weir. Tongue and groove planking makes a good temporary weir for streams not more than one or two feet deep and six to ten feet wide. Stream flow

varies greatly from season to season; thus field data must be gathered many times throughout the year [14].

MEASURING FLOW with Float

STEP 1: MEASURING CROSS-SECTION AREA

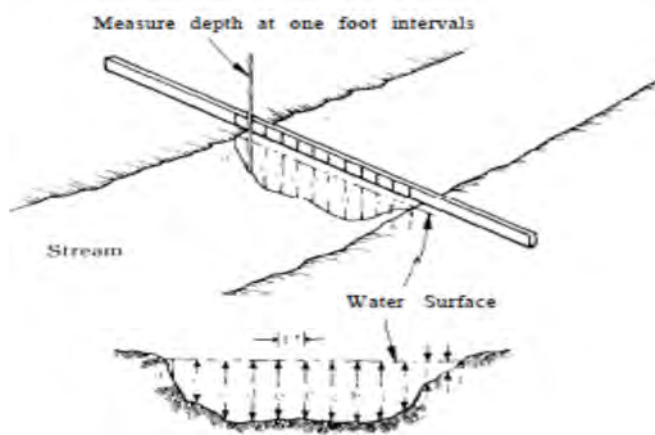

$$\text{Average depth} = \frac{\text{Sum of measured depths}}{\text{Interval measured}}$$

STEP 2: MEASURING WATER VELOCITY

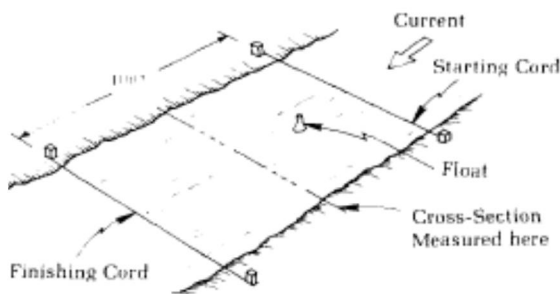

Fig 3.3 flow rate measuring procedure

STEP 3: CALCULATING FLOW RATE

The flow rate is calculated by the formula:

$$Q = 0.83 \left(\frac{bd}{144} \right) \left(\frac{100}{t} \right)$$

Q = flow rate, cubic feet per second

b = stream width, inches

d = average stream depth, inches

t = time for float to drift 100 feet, seconds

b) Measuring Head

After the height of the water behind the proposed dam or diversion has been decided, it is necessary to measure the head of water that will result. To determine the difference in level between two points, set a surveyor's level about midway between the points. Have an assistant hold a surveyor's rod at one point, sight through the level and record the height reading on the rod. Move the rod to the second point and read. The difference of the readings is the difference in elevation of the two points. Often it is impossible to see the two points from a single setting of the level so rods must be read at intermediate or turning points. The differences in readings between each pair of points can be added together to calculate the total elevation drop from the dam or diversion [15].

MEASURING the HEAD

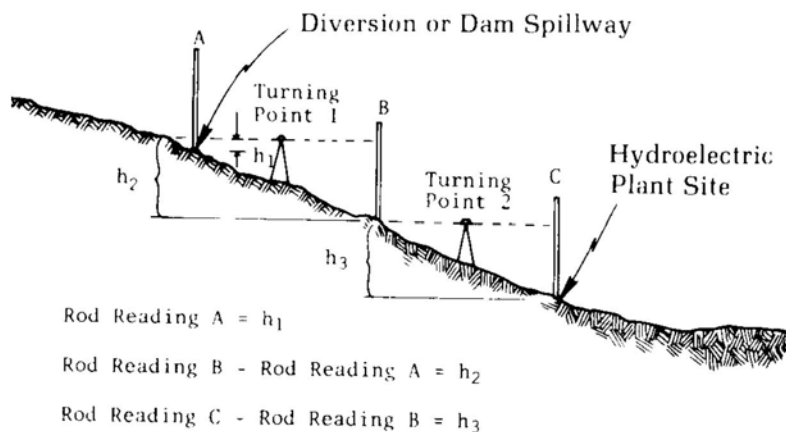

Fig 3.4 head measuring technique of small hydro power[15]

$$HEAD = h_2 + h_3 - h_1$$

Calculating Power

Power output, in kilowatts is calculated by the formula:

$$KW = 0.0846 \times E \times Q \times H$$

Where: Q = water flow, cubic feet per second

H= head, feet

E = efficiency of hydroelectric plant, percentdivided by 100.

Friction, generator losses and turbine losses reduce the efficiency of a power plant. Small plants are about 40% efficient. Five to ten kilowatt plants may be 60 to 70% efficient when operating at full capacity. For initial estimates, calculate power based on 50% efficiency.

3.6 Components of Small hydro power

a) P e n s t o c k s

Friction in the pipe (penstock) or open channel that carries water to the generator is another cause of power loss. Most small hydroelectric sites have a small or moderate head, so it is very important to use large penstocks to reduce losses. If you are diverting a water source far up the hill, plastic or aluminum irrigation pipe and the heavier walled, pressure rated PVC plastic pipe make good penstocks.[15]

b) Trash Racks and Head Gates

Even small streams can become torrents carrying large trees and other debris. Plan to protect the generator and water passages from debris by installing a trash rack at the head of the penstock. Set steel bars on edge to the flow of water and space about 1" apart. Normally trash racks are set on an incline to increase area so water velocity is less than 1.5 feet per second through the rack. An inclined rack is easier to clean with a rake. This feature is particularly important in the fall because leaves may blanket a rack in an hour or two. A head gate or valve should be installed below the trash rack to control flow and to allow the turbine to be inspected and repaired.

c) Turbines

The towering water wheel driving the old mill's grinding stones creates a romantic image, but it is too slow and ponderous to efficiently convert water power to electric power. For example, a 5 foot diameter wheel that is 16" wide will generate only 300 watts or less. A compact turbine and generator is a better choice unless you are renovating an old mill site. Hydroelectric plants are available in capacities ranging from 1/2 KW to 12 KW. A reaction turbine, either the Francis type or propeller wheel type, is turned by a mass of water falling through a duct encasing a wheel. Reaction-type generators are good choices if you have ample water supply but a low head. A reaction wheel is subject to greater friction losses than an impulse wheel; however, it has greater flexibility in installation. Penstock

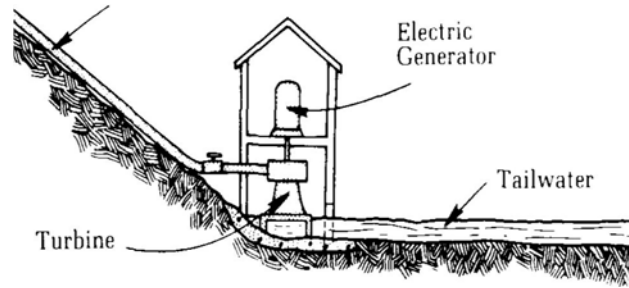

Fig 3.5 Reaction Turbine [16]

An **impulse** (Pelton) turbine turns by the velocity of a jet of water striking the turbine's wheel cups and can operate on as little as 1.5 cfm of water. In order to be most effective, a head of at least 50' is required.

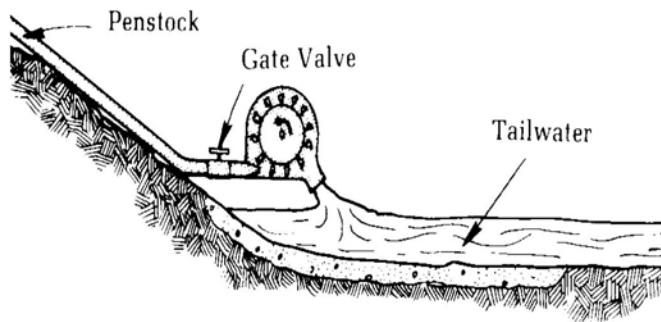

Fig 3.6 IMPULSE TURBINE [16]

The type of facility you wish to provide with electrical service will largely determine whether you use an Alternating or Direct-Current generator. Lights and the universal motors that operate small appliances and tools will operate on DC. Larger motors, TV's and many appliances require AC to operate. Alternating Current may be transmitted greater distances and on smaller wires than is possible with Direct Current; however, an AC installation does require an extra investment in governing equipment. Direct Current generators are usually less expensive than AC generators but they do require expensive inverters to convert to AC. The potential of storing DC in batteries during low-usage periods and at times of uneven water flow is a compensation of such a system.

3.7 Causes of Failure

The main reasons for lack of success with small water power developments are:

1. Failure to realize how important full field data is for proper design
2. Failure of homemade equipment made with junked parts.
3. Over-estimating the amount and constancy of the stream flow.

4. Penstocks or flumes that is too small to allow the plant to operate at full capacity.
5. Failure to anticipate the expense of keeping trash racks clear and machinery in good repair.
6. Failure to design and plan for winter ice buildup.
7. Overestimation of a proposed plant's capability. The average home has demand peaks varying from 4 to 12 kilowatts.[16]

3.8 Pumped storage Hydropower system

The pumped storage is a system of generating electricity, also known as hydroelectric storage, which uses water that has been pumped into an elevated reservoir during the hours of low consumption to generate electricity during hours of peak demand. This type of hydroelectric system is used by some power plants for load balancing. The method stores energy in the form of water (potential mechanical energy) from a lower elevation reservoir to a higher elevation. In a conventional electrical system, the low-cost off-peak electrical power is used to run the pumps and the stored water is released during periods of high electrical demand, generally with a cost benefit. In a “Renewable energy system”, at time of low electrical demand, excess generation power produced by the renewable energy system (wind turbine and/or photovoltaic system) is used to pump water into a higher reservoir and then, when there is a higher demand, the water is released back in the lower reservoir through a turbine, generating electricity.

There are two possibilities:- two water ways: one for the pumping, the other for the turbine- one unique water way : a reversible machinery (usually a Francis Turbine design) is used for both pumping and generating; it is designed as a motor and pump in one direction and as a turbine and generator in opposite rotation Fig3.7.

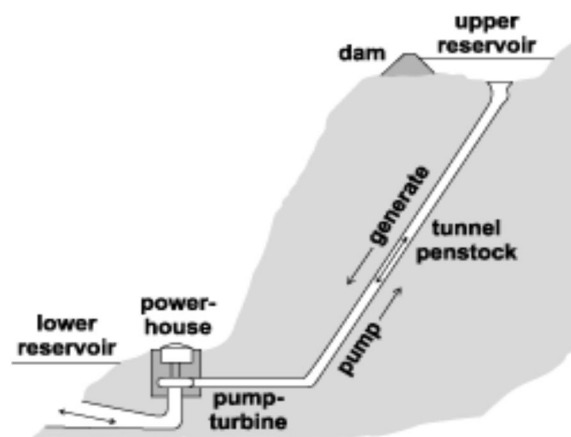

Fig 3.7 Schematic of a conventional pumped-storage development with one reversible pump.[18]

The station is located underground if the geological conditions are favorable; otherwise it is situated on the lower reservoir. Pumped hydro is available at almost any scale with discharge times ranging from several hours to a few days. The advantages of such systems are [18]:

- More than 100 years of experience;
- High efficiency: in the 70% to 85% range.
- Multipurpose facilities;
- Environmental friendly;
- CO₂- avoiding;
- Highest availability compared to other technologies;
- Quick response to load variation (some seconds) and reserve capacity.

Taking into account evaporation losses from the exposed water surface and conversion losses, approximately 70% to 85% of the electrical energy used to pump the water into the elevated reservoir can be regained. We note that hydro pumped system (PSH) is adapted for high rated power (400 to 4000 MW) with high discharge time between 10 and 100 hours [18].

Another implementation of pumped storage system is hybrid plant combination with wind farm. Energy produced by wind turbine at wind farm is used to drive pump at pumping station as shown fig 3.8

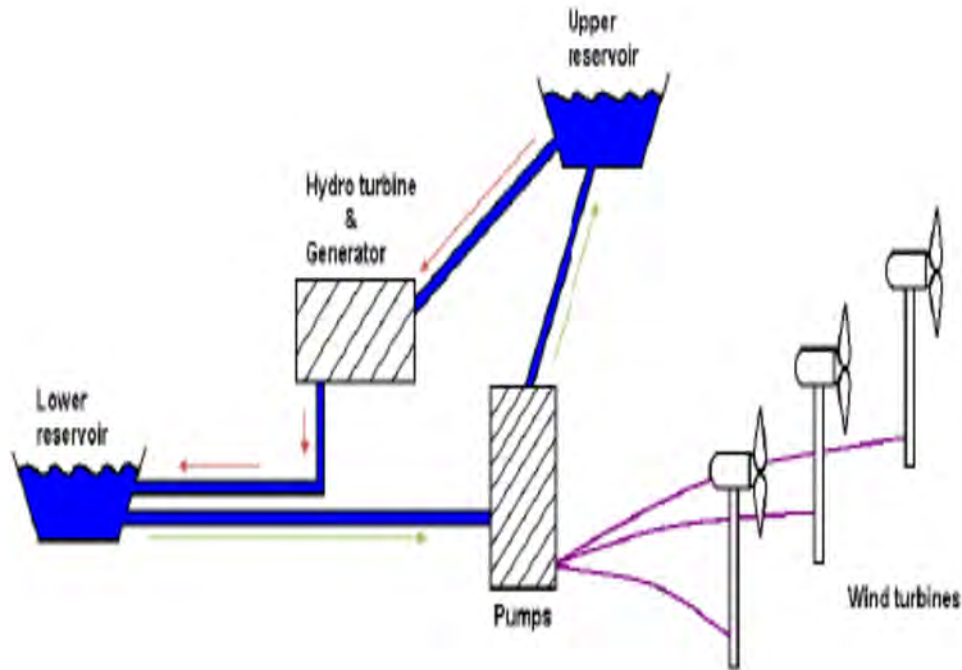

Fig 3.8 Pumped storage system with wind turbines producing electricity [17]

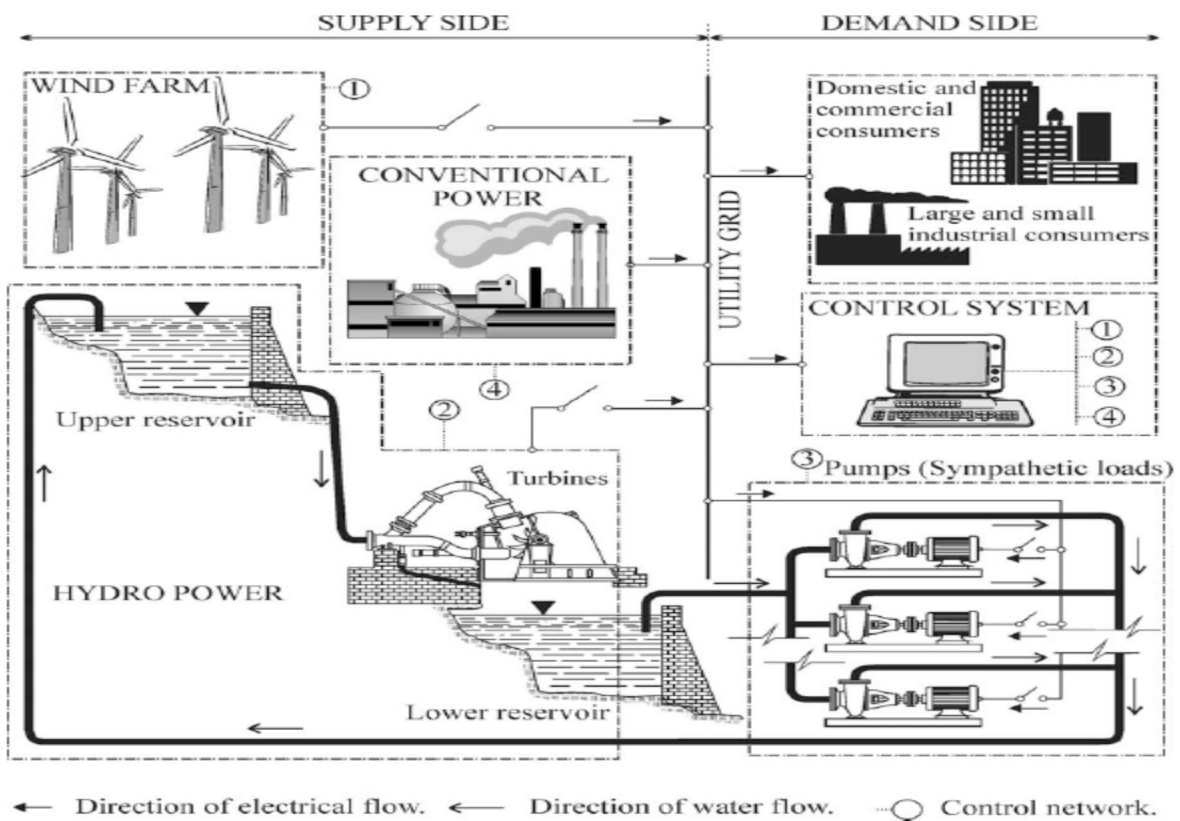

Fig 3.9 Overall system Pumped Storage Hydro System

3.9 Designed Micro hydro using pumped storage system

The amount micro hydro to be designed is 30KW

The available amount of head is 100m

$$P \text{ (KW)} = 9.81QHE$$

3.1

Where Q is flow rate

H is Available amount of head = 100m

E is turbine efficiency = 0.85

$$30KW = 9.81*Q*100*0.85$$

Then Q is $0.03599\text{m}^3/\text{s}$

If micro hydro operates for 12 hours the total amount of water in reservoir is

$$\text{Total amount of water in reservoir} = 0.03599\text{m}^3/\text{s} * 60 * 60 * 12 = 1554.78\text{m}^3$$

So the pump operating time used to pump water to reservoir is 10 hr/day

The amount of flow rate discharge water in to the reservoir is

$$1554.78 * 1000 / (10 * 3600) = 43.188\text{lit/sec}$$

a) Then the hydraulic power is

$$P = 9.81 * Q * H$$

$$P = 9.81 * 43.1888 * 100 = 42.3\text{KW}$$

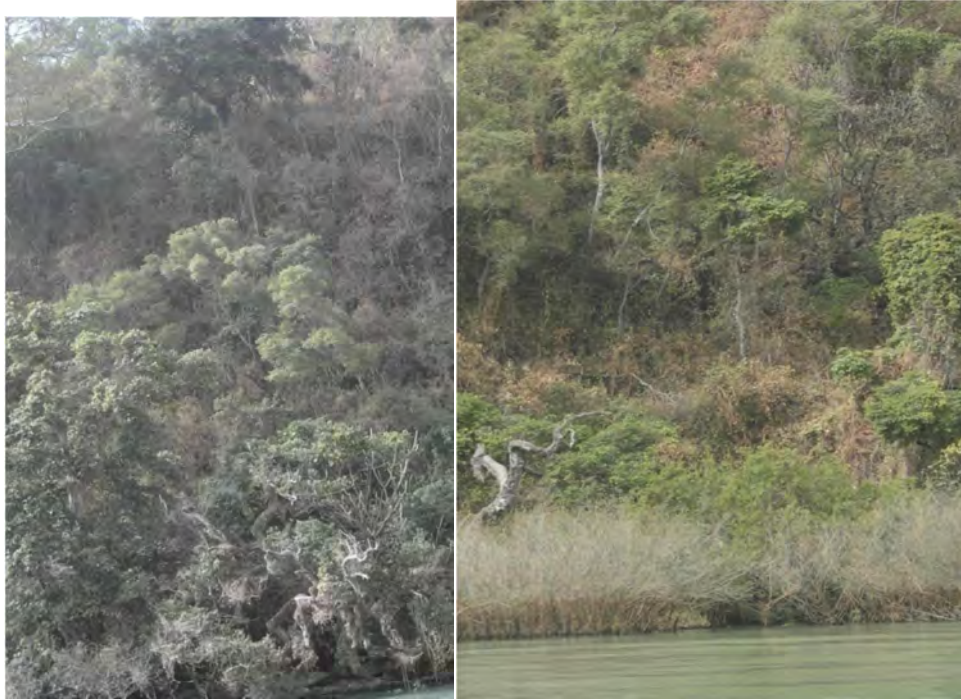

Fig 3.10 Available head on Deck Island 100m above ocean

b) Design of pump motor

$$\text{Motor power} = \frac{P}{\eta} \quad 3.2$$

Where P = is hydraulic power

η = efficiency of pump

Typical pump efficiency is 75%

$$P = 42.3\text{KW}/0.75 = 56.4\text{KW}$$

Mechanical energy required is

$$56.4\text{KW} \cdot 10 = 564\text{KWh}$$

CHAPTER 4

Wind power and Wind Resource in Ethiopia

Ethiopia has exploitable reserve of 10,000 MW wind energy with an average speed of 3.5 – 5.5 m/s, flowing for 6 hours/day. There are two basic zones with homogenous periodicity separated by the rift valley. In the first of these, covering most of the highland plateaus, there are two well-defined wind speed maximal occurring, respectively, between March and May and between September and November. In the second zone, covering most of the Ogaden and the eastern lowlands, average wind velocity reaches maximum values between May and August [19-21]. Currently two projects are being constructed, one Ashegoda wind park (near Mekele) of 120MW and the other Adama Wind Park of nearly 51MW.

4.1 Wind Power Generation

Wind power, like most sources of energy on earth, originates from the sun. As the earth orbits the sun daily, it receives light and heat. Across the earth there are areas with different temperatures, so that heat transfers from one area to another. These heat differences help to create wind: in warmer regions of the earth, the air is hot and is therefore at a high pressure, compared with the air in colder regions, where it is at a low pressure. Wind is the movement of the air from high pressure to low pressure. The idea of creating something to capture the power from the wind is not a new idea. Wind turbines have been used for thousands of years for milling grain , pumping water, and other mechanical power applications. Today, there are over one million wind turbines in operation around the world. Most of them are used for water pumping and for generating electricity. Wind energy offers the potential to generate substantial amounts of electricity without the pollution problems of most conventional forms of electricity generation [22, 23].

4.2 Wind Energy Resources

Wind resource is the most important element in determining turbine performance at a given place. The energy that can be extracted from a wind stream is proportional to the cube of its velocity. In addition, the wind resource itself is intermittent. It varies with year, season, and time of day, elevation above ground, and form of terrain. Proper choice of site which is free from large obstructions, improves wind turbines performance.

4.3. Wind Speed Measurement

Anemometer

The wind speed is measured with an instrument called an anemometer. These instruments come in several types. The most common type is a cup anemometer which has three or four cups attached to a rotating shaft. When the wind hits the anemometer, the cups and the shaft rotate.

The angular speed of the spinning shaft is calibrated in terms of the linear speed of the wind.

Normally, the anemometer is fitted with a wind vane to detect the wind direction. A data logger collects wind speed and wind direction data from the anemometer and wind vane respectively.

It is very important that the measuring equipment is set high enough to avoid turbulence created by trees, buildings or other obstructions. Readings would be most useful if they have been taken at hub height where the wind turbine is going to be installed [24].

If the measurement of wind speed was not made at the wind turbine hub height (in this case it is 25 m) it is important to adjust the measured wind speed to the hub height. This can be done using either the logarithmic law, which assumes that the wind speed is proportional to the logarithm of the height above ground, or the power law, which assumes that the wind speed varies exponentially with height. Using the logarithmic law the wind speed at a certain height above ground level can be given as follows [16]:

$$V = V_{ref} * \frac{\ln\left(\frac{Z}{Z_o}\right)}{\ln\left(\frac{Z_{ref}}{Z_o}\right)} \quad 4.1$$

Where V is wind speed at height Z above ground level (m/s), V_{ref} is reference speed (m/s), i.e.

a wind speed already known at height Z_{ref} , $\ln(\dots)$ is the natural logarithm function, Z is height above ground level for the desired speed (m), V , Z_o is roughness length in the current wind direction (m), and Z_{ref} is reference height (m), i.e. the height where we know the exact wind speed V_{ref} .

Using power law the wind speed at a certain height above ground level can be given as follows [17]:

$$V_2 = V_1 * \left(\frac{h_2}{h_1}\right)^\alpha \quad 4.2$$

Where: V_1 is wind speed measured at the reference height h_1 (m/s), V_2 is wind speed estimated at height h_2 (m/s), and α is ground surface friction coefficient.

Table 4.1 Friction Coefficient of Various Terrains [17]

Terrain Type Friction Coefficient	Terrain Type Friction Coefficient
Lake, ocean and smooth hard ground	0.10
Foot-high grass on level ground	0.15
Tall crops, hedges, and shrubs	0.2
Wooded country with many trees	0.25
Small town with some trees and shrubs	0.3
City area with tall buildings	0.4

4.4 Wind Power

Energy available in wind is basically the kinetic energy of large masses of air moving over the Earth's surface. Blades of the wind turbine receive this kinetic energy, which is then transformed to useful mechanical energy, depending on end use. The kinetic energy of a stream of air with mass m (kg) and moving with a velocity V (m/s) is given in joules by the following equation [17]:

$$KE = \frac{1}{2} mV^2 \quad 4.4$$

A wind rotor of cross sectional area A in m^2 is exposed to this wind stream with velocity V in m/s as depicted in Figure 9 below. The kinetic energy of the air stream available for the turbine can be expressed as:

$$KE = \frac{1}{2} \rho v V^2 \quad 4.5$$

Where ρ is the density of air (kg/m^3) and v is the volume of air parcel available to the rotor (m^3). The air parcel interacting with the rotor per unit time has a cross-sectional area equal to that of the rotor area (A_T) and thickness equal to the wind velocity (V). Hence energy per unit time, that is power in the wind, can be expressed as:

$$P = \frac{1}{2} \rho A_T V^3 \quad 4.6$$

From above equation we can see that the factors influencing the power available in the wind stream are the air density, area of the wind rotor and the wind velocity. Effect of the wind velocity is more prominent owing to its cubic relationship with the power

The most accurate estimate for wind power density in W/m² is that given by equation below [18].

$$\frac{P}{A} = \frac{1}{2} \frac{1}{n} \sum_{i=0}^n (\rho_j \cdot V_j^3) \quad 4.7$$

Where n is the number of wind speed readings and ρ_j and V_j are the jth readings of the air density (kg/m³) and wind speed (m/s) respectively.

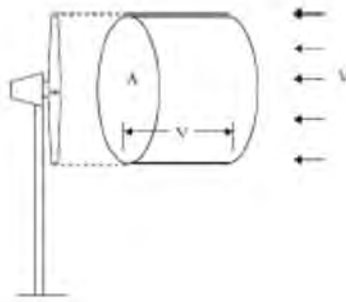

Fig 4.1 an air parcel moving towards a wind turbine [25]

4.5 Wind Energy Conversion System

The block diagram of a typical wind energy conversion system is shown on figure 4.2 .

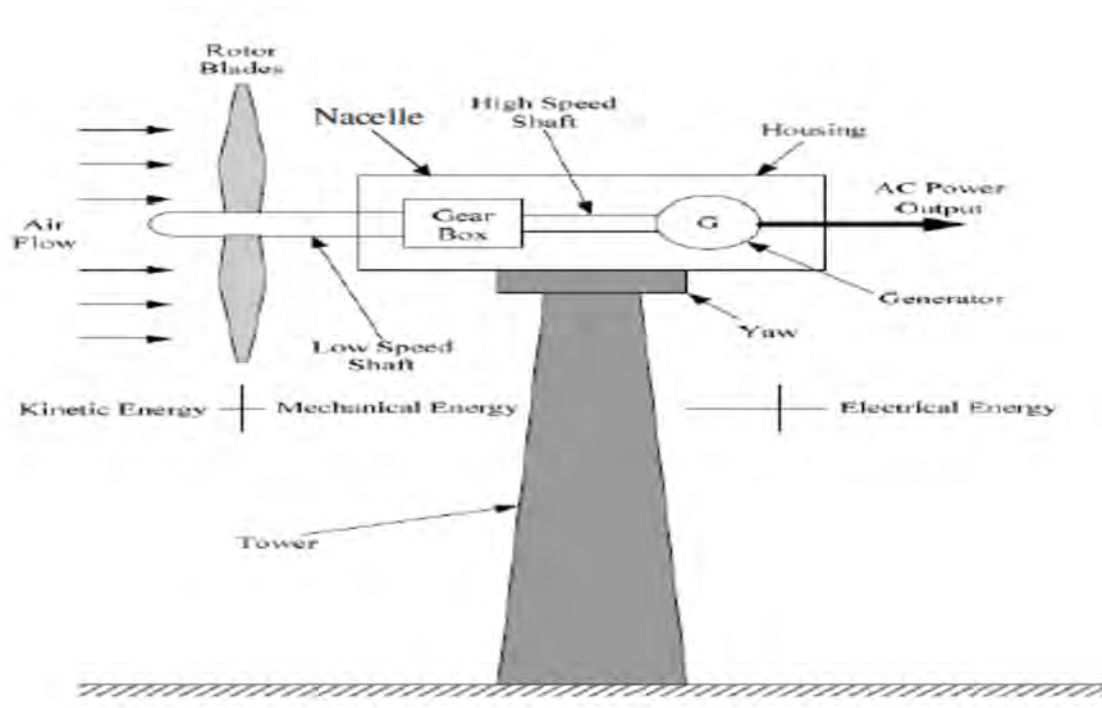

Fig 4.2. Block diagram of wind energy conversion system [25].

Modern wind turbine comprises of the principal components such as the tower, the yaw, the rotor and the nacelle, which houses the gear box and the generator. The tower holds the main part of the wind turbine and keeps the rotating blades at a height to capture sufficient wind power. The yaw mechanism is used to turn the wind turbine rotor blades in direction of the wind. The gearbox transforms the slower rotational speeds of the wind turbine to higher rotational speeds on the electrical generator side. Electrical generator will generate electricity when its shaft is driven by the wind turbine, whose output is maintained as per specifications, by employing suitable control and supervising techniques [9].

4.6 wind energy estimation of Deck Island

a) Wind assessment

Once an area has been chosen for assessment, it is necessary to collect wind speed and direction data. A complete wind resource assessment involves a dense network of anemometers (wind monitoring stations) recording continuous wind data for at least one year. Since such wind monitoring efforts are time consuming and costly, wind researchers often obtain data sets that have been previously recorded.

b) Finding mean wind speed

The next step in the wind resource assessment is to analyze the wind data set to determine patterns in the magnitude, duration and direction of the wind.

Mean wind speed (V_m) is the most commonly used indicator of wind production potential where defined as

$$V_i = \frac{1}{N} \sum_{i=1}^N V_i \quad 4.8$$

Where N is the sample size, and V_i is the wind speed recorded for the i^{th} observations. Where the sample size is large, it is useful to group the wind speed data into intervals to create a histogram of the wind speed distribution.

c) Distribution of Wind Speed

The distribution of wind is expressed by Weibull distribution which is called a Raleigh distribution for $K=2$. It is given by equations (4.9 to 4.11).

$$f(v) = \frac{\pi \cdot v}{2\bar{v}^2} \exp\left[-\frac{\pi}{4}\left(\frac{v}{\bar{v}}\right)^2\right] \quad 4.9$$

$$\text{prob}(v \leq V) = 1 - \exp\left[-\frac{\pi}{4}\left(\frac{v}{\bar{v}}\right)^2\right] \quad 4.10$$

$$\text{prob}(v \geq V) = \exp\left[-\frac{\pi}{4}\left(\frac{v}{\bar{v}}\right)^2\right] \quad 4.11$$

where, $f(v)$ = Weibull probability density function of wind distribution

\bar{v} = mean wind speed (m/s)

v = instantaneous wind speed (m/s)

$\text{prob}(v \leq V)$ = probability of instantaneous wind speed is less than V

$\text{prob}(v \geq V)$ = probability of instantaneous wind speed is greater than V

Wind speeds are always measured at 10 m height anemometer. But, wind turbines are installed at higher elevations at which the wind speed is completely different from the 10 m measurement. This variation of wind speed with height can be expressed with equation 4.2

d) Annual energy and capacity factor

The calculation of the annual energy yield of a wind turbine is of fundamental importance in the evaluation of any project. The long-term wind speed distribution is combined with the power curve of the turbine to give the energy generated at each wind speed and hence the total energy generated throughout the year. It is usual to perform the calculation using 1m/s wind speed bins as this gives acceptable accuracy. The annual energy expressed mathematically as

$$\text{Energy} = \sum_{i=1}^{i=n} H(i)P(i) \tag{4.12}$$

Where H(i) is the number of hours in wind speed bin i and P(i) is the power output at that wind speed. Another measure is the load or capacity factor, defined as the ratio of the actual energy generated in a time period to the energy produced if the wind turbine had run at its rated power over that period.

The power in wind is given by

$$P \text{ (w/m}^2\text{)} = 0.5 \times \text{air density} \times \text{swept rotor Area} \times (\text{wind speed})^3 \tag{4.13}$$

$$P \text{ (w/m}^2\text{)} = 1/2 \rho AV^3$$

$$\text{Air Density} = \frac{p}{R \times T} \text{ (Kg/m}^2\text{)} \tag{4.13.1}$$

P pressure (pa)

R specific gas constant (287J/Kg.K)

T Air Temperature (K)

$$\text{Area (A)} = \pi r^2 \text{ (m}^2\text{)} \tag{4.13.2}$$

Using the above equations (4.8 to 4.13) wind energy of the selected site shown as follows

Selected wind turbine is 30KWAC

Rotor Diameter 13m

Table 4.2 Generated power of the turbine at specific wind speed

Wind speed (m/s)	Power (KW)
0	0
1	0
2	0
3	0.5
4	1.6
5	3.5
6	7
7	12

Table 4.3 Available Energy in each month of the project site

month	Wind speed at 10m height (m/s)	Wind Speed at 25 m height (m/s)	Month hour (hr)	Power (kW)	Energy (MWh)
January	4.0	4.8	315.15	3.2	1.008
February	4.1	4.9	316.15	3.4	1.074
March	4.0	4.8	315.15	3.2	1.008
April	4.0	4.8	315.15	3.2	1.008
May	3.6	4.3	348	2.2	0.765
June	4.5	5.4	253	4.5	1.138
July	4.7	5.64	230	5.25	1.207

August	4.2	5.05	288.5	3.5	1.009
September	3.4	4.08	326	1.7	0.978
October	2.9	3.48	253	0.75	0.2
November	3.5	4.2	337	2.0	0.64
December	3.9	4.68	394	2.8	1.103
Average	3.9	4.68			
Summation					11.138

Annual energy at average (mean) speed is $= 0.456 * 8760 * 5 = 19.97 \text{MWh}$

CHAPTER 5

5. Hybrid System Optimization using HOMER

5.1. Introduction

HOMER, the micro power optimization model, simplifies the task of evaluating designs of both off-grid and grid-connected power systems for a variety of applications. When we design a power system, we must make many decisions about the configuration of the system: What components does it make sense to include in the system design? How many and what size of each component should you use? The large number of technology options and the variation in technology costs and availability of energy resources make these decisions difficult. HOMER's optimization and sensitivity analysis algorithms make it easier to evaluate the many possible system configurations. HOMER simulates the operation of a system by making energy balance calculations in each time step of the year. For each time step, HOMER compares the electric and thermal demand in that time step to the energy that the system can supply in that time step, and calculates the flows of energy to and from each component of the system. For systems that include batteries or fuel-powered generators, HOMER also decides in each time step how to operate the generators and whether to charge or discharge the batteries.

HOMER performs these energy balance calculations for each system configuration that we want to consider. It then determines whether a configuration is feasible, i.e., whether it can meet the electric demand under the conditions that you specify, and estimates the cost of installing and operating the system over the lifetime of the project. The system cost calculations account for costs such as capital, replacement, operation and maintenance, fuel, and interest. After simulating all of the possible system configurations, HOMER displays a list of configurations, sorted by net present cost (sometimes called lifecycle cost), that we can use to compare system design options. When we define sensitivity variables as inputs, HOMER repeats the optimization process for each sensitivity variable that we specify. For example, if we define wind speed as a sensitivity variable, HOMER will simulate system configurations for the range of wind speeds that we specify. With efficient, reliable and cost-effective renewable energy resources, off-grid supply can be used as an alternative to the power supplied by diesel generator for rural electrification. However, due to intermittency nature of renewable resources, use of any

particular renewable energy resource based system may lead to component over-sizing and unnecessary operational and lifecycle costs. Such limitations can be overcome by combining one or more renewable energy resources in a form of a hybrid system. Hybrid systems improve load factors plants and save maintenance and replacement costs, as the renewable resource components complement each other [26]. For optimal combination of different renewable, various types of hybrid systems and methods of techno-economic analysis are used. HOMER is the most commonly used methods of hybrid system optimization techniques [26-28].

5.2. Basic Components and Model of Hybrid System

The basic components of the hybrid system are the hydro system, the wind plant and the PV system. Others are additional/auxiliary components which help for full time functioning of the hybrid system. The principle of operation of the basic components has been covered before. The principle of operation for diesel generator is same as generators used for hydro except the prime mover, in this case, is diesel engine. Figure 5-1 shows schematic of the hybrid system.

The power conditioners are set of power electronics converters which enable to handle the variability of wind and solar resources. They are composed of DC/DC, AC/DC, DC/AC converters. The AC output of the hydropower, diesel and generator are integrated and controlled in such a way that the output can be directly supplied to the connected AC load. When there is excess of energy (mainly from the wind, PV and hydro), it is directed to the battery through the converter and DC center. In addition, frequency and voltage regulation control circuitry is to be included in the operation and control center. Similarly, the DC output of the PV panel is connected to the system via the DC center. The DC center is integrated with the system through DC/AC and AC/DC converters. As well as, it is connected to PV and battery components. Since the scope of this study is limited to the feasibility assessment of energy resources, detailed analysis of each component of the hybrid system are not covered.

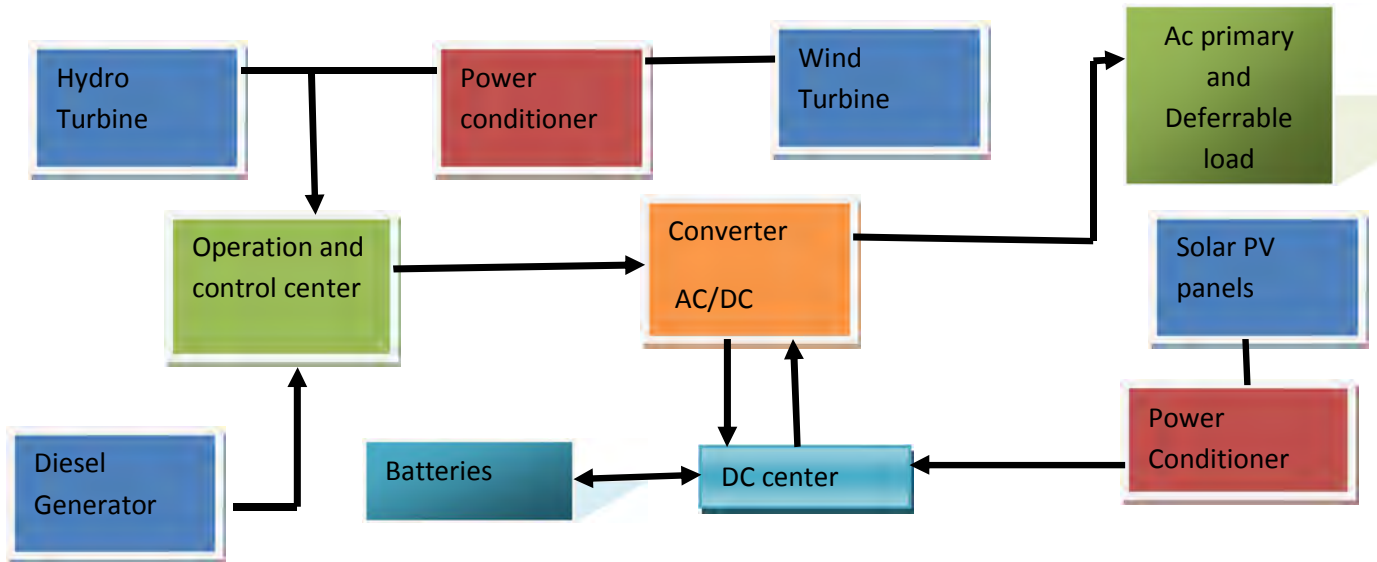

Figure 5-1 General scheme of Small Hydro/PV/Wind hybrid system

a) Converter

Converters are generally four types: DC/DC, DC/AC, AC/DC and AC/AC. Power electronics devices (such as IGBT, power MOSFET, power Transistor, Thyristors, etc.) are used as a switching gate in different pattern of arrangement to achieve the required conversion output. DC/DC converters are classified as boost, buck and buck-boost converters based on their output voltage relative to their input (possibility of “step-up”, “step-down” or both respectively). They convert a given DC voltage level to the required voltage level. DC/AC converters (also called, inverters) can be classified based on the triggering signal as square wave, sine wave or modified sine wave. These devices use a given DC voltage as input and output the required voltage of a given amplitude and frequency. AC/DC converters (also called rectifiers) operate in the reverse principle of inverters. AC voltage source is used as input which passes through half or full bridge circuit (with a firing angle control) to result a rectified DC voltage output. AC/AC converters are used for conversion of AC voltage of a given frequency and amplitude to another AC voltage of the required amplitude and frequency.

B) Battery

The one important reason of a hybrid system is to reduce component over-sizing by storing the excess energy available at one time for usage during shortage time. There are different types of storage mechanism such as batteries, pumped storage, hydrogen, fly wheels etc. Rechargeable batteries are widely used for implementation of hybrid energy systems because of their cheapness and easy operation.

Battery is a device in which the chemical energy of an electrolyte is converted into electrical energy through electrodes by the process of electrolysis. They are referred to as secondary cells (which can be recharged). The main parameters of selecting batteries are maximum throughput and minimum state of charge. Maximum throughput is measured by the output of the battery (in ampere-hour) that can be delivered throughout its life time. Minimum state of charge is the measure of how low the battery can be discharged as a percentage of its full capacity without losing its performance. There are very deep cycle batteries which can be discharged up to 40% such as Block type lead acid battery [27]. The two battery types that have been used for PV systems are lead–acid and nickel–cadmium. Due to higher cost, lower cell voltage (1.2 V), lower energy efficiency and limited upper operating temperature (40° C). The lead–acid battery will remain the most important storage device in the near future, especially in PV systems of medium and large size [29].

Lead–acid battery characteristics

A - Voltage, specific gravity and state-of-charge

The nominal voltage of a lead–acid cell is 2V, while the upper and lower limits of discharging and charging open circuit voltage at 25°C cell temperature are 1.75 and 2.4V, which corresponds to 10.5 and 14.4V for a 12V battery (respectively)[29]. The maximum acceptable battery cell voltage decreases linearly with increasing cell temperature as illustrated in Fig. (5.2). The specific gravity of the acid solution of the battery decreases lightly with increasing temperature. Cell voltage and specific gravity of the acid solution are mainly a measure for the state-of-charge of the battery cell.

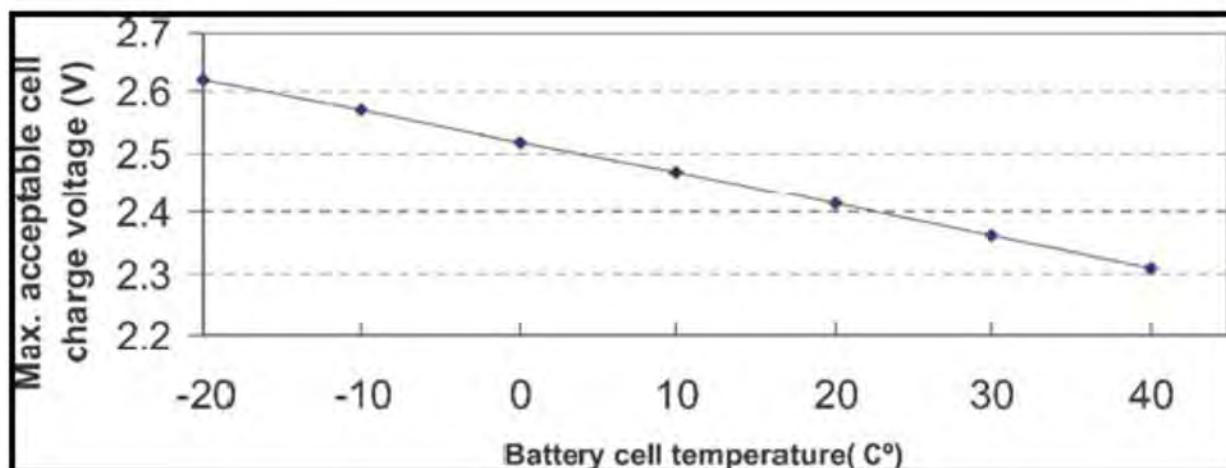

Fig 5.2 Maximum acceptable battery cell charge voltage in function of internal cell temperature [29].

The depth of discharge (DOD) is the obverse of state-of-charge. Cell voltage decreases almost linearly with depth of discharge until a point called cut-off-voltage is reached.

Battery cells should not be operated beyond the cut off voltage, because further discharge will result in increasing the internal resistance of the battery and can result in permanent damage. On other hand,

Overcharging the batteries until gassing leads also to cell damage [30].Therefore, batteries have to be connected to the output of the PV generators and the load via a charge regulator .This regulator protects the battery against deep discharge and excessive overcharge. Lead–acid battery cells are available with either pure lead or lead–calcium grids to minimize the self-discharge rate. All lead–acid cells have some loss in capacity on standing due to internal chemical reactions .Fig.(5.3) presents typical self-discharge rates for a cell containing antimony or calcium grids. Self-discharge rate, increases with increasing cell temperature and remain relatively low for cell with lead calcium grids [29].

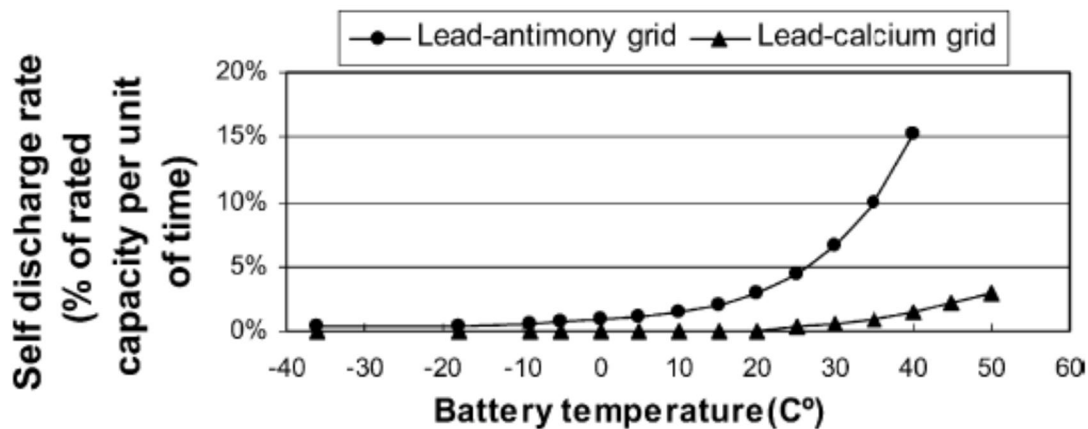

Fig 5.3 Lead–acid battery self-discharge rate in function of cell Temp. [30]

5.3. Simulation using HOMER

HOMER has three main windows which are used to enter necessary data to the software. The first is Add/Remove window where technologies to be considered are selected. The second window is Resource window which shows the type of energy source that are to be used corresponding to the equipment’s selected in the Add/Remove window. The third one is the others window where economics, emission, constraints and system controls are defined. Details of each element in these windows should be defined. In this study, wind turbine (type, cost, hub height, life time and number), micro hydro (cost, head, design flow rate, efficiency, minimum and maximum flow rate ratio, life time and head loss), PV (size, cost,

slope, ground reflectance, derating factor, life time), converter (cost, efficiency, size and life time), diesel generator (cost, size, minimum load ratio, fuel curve, type of fuel and life time), battery (type, cost and number of strings, life time), primary load (hourly data for the year, daily and hourly noise) and deferrable load (monthly average daily load, minimum ratio and storage capacity) are added to the system. Details of solar, wind, hydro and diesel resources are defined. In the solar resource window, monthly averaged daily solar radiation data, location and time zones are defined which are used by the software to calculate the hourly incident solar radiation on the PV panel. In the wind resource window, monthly averaged wind speed data, altitude, anemometer height, variation with height, Weibull k, autocorrelation factors, diurnal pattern strength, hour of peak wind speed are defined which are used by HOMER to estimate the wind distribution and output power. In the hydro resource window, the monthly average stream flow and residual flow are defined. The diesel cost is defined in the diesel resource window. A dispatch strategy is a set of rules that govern the operation of the generator(s) and the battery bank. HOMER can model two dispatch strategies, cycle charging and load following. Which is optimal depends on many factors, including the sizes of the generators and battery bank, the price of fuel, the O&M cost of the generators, the amount of renewable power in the system, and the character of the renewable resources. If we choose to model both, HOMER will simulate each system using both dispatch strategies and you will be able to see which is optimal. Under the load following strategy, whenever a generator is needed it produces only enough power to meet the demand. Load following tends to be optimal in systems with a lot of renewable power, when the renewable power output sometimes exceeds the load. Under the cycle charging strategy, whenever a generator has to operate, it operates at full capacity with surplus power going to charge the battery bank. Cycle charging tends to be optimal in systems with little or no renewable power. If you can apply a set point state of charge to the cycle charging strategy, the generator(s) will not stop charging the battery bank until it reaches the specified state of charge. The sensitivity button to the right allows us to do a sensitivity analysis on this set point. Interest rate and project life time are defined in the economics window. Greenhouse gas emission penalty are defined in the emission window. Maximum annual capacity shortage, minimum renewable fraction and operating reserves are defined in the constraint window.

The main objective of the overall project is to propose the optimal combination of wind and PV systems together with pumped hydropower in a form of a hybrid system, which will improve the system reliability and investment costs. HOMER simulates all the possible system configurations based on the combinations of the components specified to it as input data and discards the infeasible system configurations that do not adequately meet the suggested load with the available resource and/or specified constraints [31]. Hence, only feasible combinations are displayed according to the total net present cost

(NPC) in an increasing order. The optimization results are given out in an overall form and in a categorized form. For a particular set of sensitivity variables (solar radiation, average wind speed, diesel price, etc.), the overall table displays all feasible system configurations according to cost effectiveness. The categorized table displays only the most cost effective configuration from each possible hybrid system types.

It is to be noted that the results can further be refined with the refinement of the component sizes, but at a cost of much longer running time of the software. In this work a step by step repeated simulation is carried out by varying different type of storage system. Since the price for diesel and for PV panels are more dynamic than other types of components, a range of diesel price and a PV capital and replacement cost multipliers are used as sensitivity parameters. HOMER displays the sensitivity analysis both in tabular and graphical form.

5.4. Load Estimation

The term loads refers to a demand for electric or thermal energy, if any. Three types of load scan be modeled using HOMER: primary load which is electric demand that must be served according to a particular schedule, deferrable load which is electric demand that can be served at certain period of time, the exact timing is not important and thermal load which is demand for heat.

a) Primary Load: Primary load is electrical demand that the power system must meet at a specific time. Electrical demand associated with lights, radio, TV, household appliances, computers, and industrial processes is typically modeled as primary load. If electrical demand exceeds supply, there is a deficit that is recorded as unmet load. The user specifies an amount of primary load in kW for each hour of the year, either by importing a file containing hourly data or by allowing HOMER to synthesize hourly data from average daily load profiles. When synthesizing load data, HOMER creates hourly load valus based on user-specified daily load profiles. Different profiles for different months and different profiles for weekdays and weekends are specified. A specified amount of randomness can be added to synthesize load data so that every day's load pattern is unique. In this thesis 5% hourly and daily load noise is defined to account for variability of load demand. According to Bekele G. et al. [21], electric load in the rural villages of Ethiopia can be assumed to be composed of lighting, radio and television, water pumps, health post and primary schools load. In this study, electricity for cooking and for flour mills is added to the load together with home radio and a TV set. Water pumps are considered as deferrable loads while the others as primary loads. As indicated previously, there are about 7000people (725 families) without electricity. All primary loads found in the island with its picture included below.

Load profile of the Islands

1) Home appliances

Table 5.1 home appliances

Appliance	Power (w)	No	Time(h)	Energy consumption (wh/day)
CFL Lamps	15	4	4	240
TV	60	1	4	240
Refrigerator	80	1	8	640
Electric mitad	2500	1	0.75	1875
Tape recorder	20	1	4	80
Mobile Charger	10	2	1	20
Charger	10	2	1	20
Others	50	2	1	100
Total energy				3215

2) Historical Monasteries



Fig 5.4 Arsemassemaete church



weba saint Giorgis church

Table 5.2 loads in historical monasteries

Appliance	Power (w)	No	Time(h)	Energy consumption (wh/day)
CFL Lamps	15	3	6	270
	15	8	6	720
	15	1	2	30
	15	1	2	30
	15	10	5	750
	15	10	5	750
	15	1	6	90
Fluorescent	50	1	6	300
	50	8	3	1200
Amplifier	415	1	3	1245
Others	50	2	1	100
Total energy				5485

3) health center



Fig5.5 Currently installed Solar panel for deck health center



Table 5.3 loads in health center

Appliance	Power (w)	No	Time(h)	Energy consumption (wh/day)
CFL Lamps	15	4	4	240
	15	4	4	240
	15	1	2	30
	15	1	2	30
	15	1	8	120
	15	1	1	15
	15	2	4	120
	15	1	1	15
Fluorescent	36	2	11	792
Charger	20	2	2	80
Vaccine Refrigerator	60	1	24	1440
Others	50	2	1	100
Total energy				3222

4) school



Fig 5.6 Deck primary School

Table 5.4 loads in primary school

Appliance	Power (w)	No	Time(h)	Energy consumption (Wh/day)
CFL Lamps	15	11	4	660
TV	100	1	4	400
Computer	250	1	5	1250
Printer	600	1	1	600
Radio	15	2	4	60
Others	50	2	1	100
Total energy				3070

5) schools

Table 5.5 loads in high schools

Appliance	Power (w)	No	Time(h)	Energy consumption (Wh/day)
CFL Lamps	15	8	4	480
TV	100	1	4	400
Computer	250	10	5	12500
Printer	600	1	1	600
Radio	15	2	4	60
VCR receiver	30	1	4	120
Small Refrigerator	80	1	5	400
Others	50	2	1	100
Total energy				14660

6) Flour-making Mill

At least two milling Motor needs in villages of Deck island. The power rating for each motor is total motor rating 5KW if it operates for 4hr per day the total energy required per day is $(2 \times 2.5\text{KW} \times 4\text{h} =$



Fig 5.7 diesel flour making milling machine in Deck island

Table 5.6 Summary of total energy for Island

Type	Number	Amount of energy required (kwh/day)	Total Amount of energy required (kwh/day)
Home appliances	725	3.215	2330.875
Historical monasteries	7	5.485	38.3775
Health center	1	2.262	2.262
Primary school	1	3.07	3.07
High school	1	14.66	14.66
Flour making milling	2	10	20
Total primary load in islands			2410.2045

b) Deferrable Load: Deferrable load is electrical demand that can be met anytime within a certain time span, which exact timing is not important. Water pumping and battery-charging are examples of deferrable loads because the storage inherent to each of those loads allows some flexibility as to when the system can serve them. The ability to defer serving a load is often advantageous for systems comprising intermittent renewable power sources, because it reduces the need for precise control of the timing of power production. If the renewable power supply ever exceeds the primary load, the surplus can serve the deferrable load rather than going to waste. For each month, the user specifies the average deferrable load, which is the rate at which energy drains out of the tank. The user also specifies the storage capacity in kWh (the size of the tank), and the maximum and minimum rate at which the power system can put energy into the tank.

There are three main deferrable loads in the villages of Deck Island

- 1) Pumped water for micro hydro
- 2) water pump for daily use
- 3) Pumped irrigated land

1) Design of Micro Hydro using Pumped storage system

As indicated above the designed micro hydro is also deferrable load it formulated for HOMER as below

Each day, 587 m³ of water is needed for one day, and there is a 1761.264m³ water tank at 100m height. At full power, the pump draws 64 KW of electrical power and pumps 58.7 m³ per hour. To model this situation using HOMER:

- 1) The peak deferrable load is 64KW, which is the rated power of the pump.
- 2) It would take the pump 30 hours at full power to fill the tank, so the storage capacity is 18 hours times 64KW, which is 1920 kWh.
- 3) It would take the pump 10 hours at full power to meet the daily requirement of water, so the average deferrable load is 10 hours per day times 64KWh, which is 640 kWh/day.

2) Energy required for daily water use in this village

Water pumping system is required for the households, the schools and health care centers. A minimum of 90 l of water per day per family and 2400 l/day for each pair of one health center and one primary school is suggested [8, 24].

a) Hydraulic energy requirement

Hydraulic energy = 9.81 * Volume (m³/day) * total head (m) / 1000

The average water requirement in developing country is 90lit/day

This village has 725 households

Total amount of water consumption is

$$725 * 90 = 65250 = 65.25\text{m}^3$$

For considerable head of 15m

$$\text{So hydraulic energy} = 9.81 * 15 * 65.25 / 1000 = 9.6\text{MJ}$$

$$9.6 / 3.6\text{Kwh} = 2.66\text{Kwh}$$

The pump operating time is 6hours/day

$$\text{The flow rate (Q)} = 65.25 * 1000 / (6 * 3600) = 3.02\text{lit/sec}$$

Then hydraulic power

$$P = 9.81Qh \text{ (watt)}$$

Where Q is flow rate and h is considerable height

$$P = 9.81 * 3.02 * 15 = 444.393W$$



Fig 5.9 Hand driven water pumping for daily use in Deck Island

b) Design of pump motor

$$\text{Motor power} = P/\eta$$

Where P = is hydraulic power

η = efficiency of pump

Typical pump efficiency is 75%

$$\text{Mechanical power required would be } 444.393/0.75 = 592.524W$$

$$\text{Mechanical energy required} = 592.52 * 6 = 3.55KWh$$

Each day, 65.25 m³ of water is needed for one day, and there is a 195.75 m³ water tank at 15m height. At full power, the pump draws 0.592 KW of electrical power and pumps 10.875 m³ per hour. To model this situation using HOMER:

- 1) The peak deferrable load is 0.592kW, which is the rated power of the pump.
- 2) It would take the pump 18 hours at full power to fill the tank, so the storage capacity is 18 hours times 0.592 kW, which is 10.656 kWh.
- 3) It would take the pump 6 hours at full power to meet the daily requirement of water, so the average deferrable load is 6 hours per day times 0.592kW, which is 3.552 kWh/day.

Energy required for irrigated land. The main considerations for pumped irrigated land are:-

- Total water required for the crop
- Frequency of irrigation required
- Amount of water required per irrigation
- Time span over which water is required

Table 5.7 daily irrigation indicators

Daily pumping hours	Water use rate (meter Per day)		
	0.2	0.25	0.33
24	0.912	1.23	1.54
20	1.23	1.93	2.03
15	1.85	2.03	2.89
10	2.21	2.95	3.7

Each day, 30 m³ of water is needed for irrigation, and there is a 90 m³ water tank at 15m height. At full power, the pump draws 820 W of electrical power and pumps 15 m³ per hour. To model this situation using HOMER:

- 1) The peak deferrable load is 0.82 kW, which is the rated power of the pump.
- 2) It would take the pump 6 hours at full power to fill the tank, so the storage capacity is 6 hours times 0.82 kW, which is 4.92 kWh.
- 3) It would take the pump 2 hours at full power to meet the daily requirement of water, so the average deferrable load is 2 hours per day times 0.82 kW, which is 1.64 kWh/day.



Fig 5.10 Diesel motor based irrigated land on island (partially)

Table 5.8 monthly deferrable load

Month	Ja	Fe	Ma	Ap	Ma	Ju	Jul	Au	Se	Oc	No	De
Average load (KWh)	56.83	56.83	56.83	56.83	56.83	55.2	55.2	55.2	56.02	56.83	56.83	56.83

5.5 Summary of Input Data to HOMER

Basic inputs

The basic inputs of the Homer includes

- a) Primary load of the research site
- b) Deferrable load of the research site
- c) Solar radiation of the research site
- d) Wind speed of the research site
- e) Designed flow rate for pumped storage system and other related data

Pumped Hydropower efficiency of 75% with 35% minimum flow ratio and 100% maximum flow ratio is taken. Derating factor of 90% and 20% ground reflectance PV system without tracking system is considered. PV panels are to be mounted at slope of 10.25° (latitude of the site). Inverter and converter efficiencies are assumed to be 90%. The Homer graphical representation of power curve for wind turbine, wind resources for selected site, Monthly global horizontal radiation of selected site are shown on the figures below.

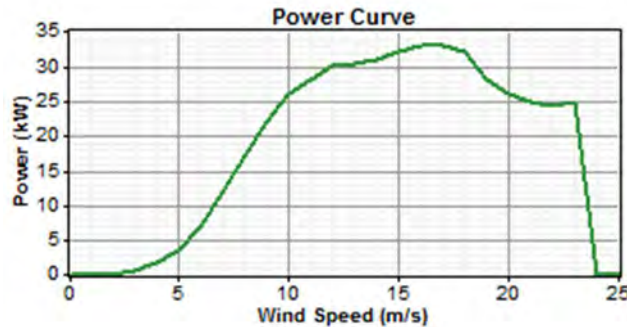

Figure 5-11 Power curve of FL30 wind turbine

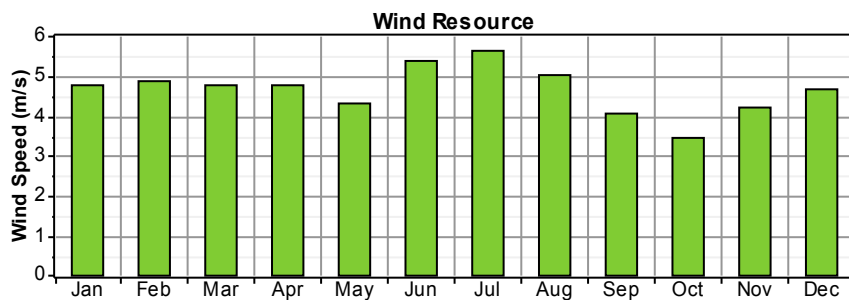

Fig5-12 wind speed in Deck Island at 25 m height

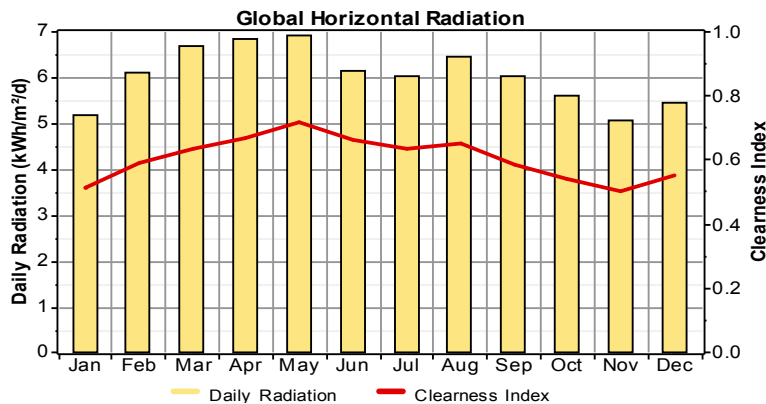

Figure 5-13 Monthly solar radiation of deck Island (kW/m^2)

Diesel generator is allowed to operate under a minimum load ratio of 70%. Its fuel curve characteristics are calculated using HOMER and an intercept coefficient of 0.02 l/hr/kW and slope of 0.23 l/hr/kW are found using data from manufacturer's website [28]. The generator efficiency against its percentage loading is shown in Figure5-14.

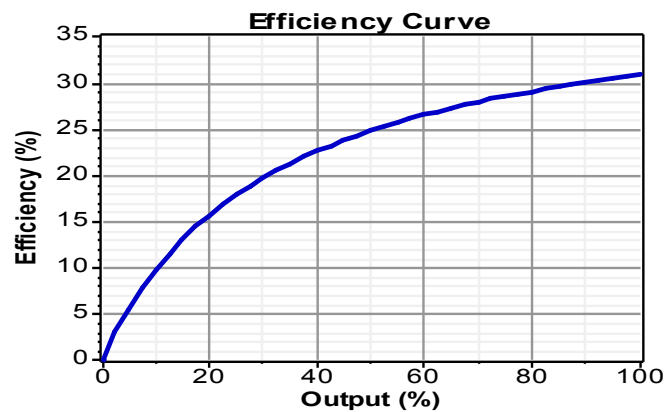

Figure 5-14 Cummins diesel generator efficiency curve

Dispatch strategy

A dispatch strategy is a set of rules that govern the operation of the generator(s) and the battery bank. HOMER can model two dispatch strategies, cycle charging and load following. Which is optimal depends on many factors, including the sizes of the generators and battery bank, the price of fuel, the O&M cost of the generators, the amount of renewable power in the system, and the character of the renewable resources. If we choose to model both, HOMER will simulate each system using both dispatch strategies and we will be able to see which is optimal. Under the load following strategy, whenever a generator is needed it produces only enough power to meet the demand. Load following tends to be optimal in systems with a lot of renewable power, when the renewable power output sometimes exceeds the load. Under the cycle charging strategy, whenever a generator has to operate, it operates at full capacity with surplus power going to charge the battery bank. Cycle charging tends to be optimal in systems with little or no renewable power. If you can apply a set point state of charge to the cycle charging strategy, the generator(s) will not stop charging the battery bank until it reaches the specified state of charge. The sensitivity button to the right allows you to do a sensitivity analysis on this set point.

Both cyclic charge (CC) and load follow (LF) dispatch strategies are considered. The load following strategy is a dispatch strategy whereby whenever a generator operates; it produces only enough power to meet the primary load. Lower-priority objectives such as charging the battery bank or serving the deferrable load are left to the renewable power sources. The cycle charging strategy is a dispatch strategy whereby whenever a generator needs to operate to serve the primary load, it operates at full output power. Surplus electrical production goes toward the lower-priority objectives such as, in order of decreasing priority: serving the deferrable load and charging the battery bank [27].

Daily and hourly primary load noise is taken to be about 5%. An operating reserve of 10% of hourly load, 25% of solar output power and 50 % wind power output respectively is suggested. To account greenhouse effect, a \$20/t of penalty for CO₂ emission is considered. Maximum annual energy shortage and minimum renewable fraction are set to 5% and 0% respectively. Interest rate of 6.7% and 25 years project life time is used for present cost analysis.

A diesel price of \$1.1, 1.2 and \$1.2/l and a PV capital and replacement cost multipliers of 0.6, 0.8 and 1 are taken for sensitivity analysis. Based on the available head the designed flow rate of the pumped storage system is 40.8l/s

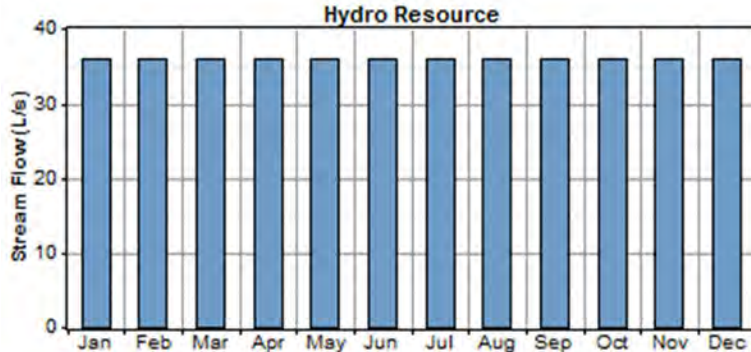

Fig5.15 designed flow rate of pumped storage system

Primary peak demand of 180kW, average primary load of 100 kW, annually averaged daily load of 2410 kWh/day and a load factor of 0.55. A deferrable peak demand of 65 kW, annually averaged daily load of 56.4 kWh/day and a storage capacity of 1935 kWh are found. The hybrid system set up developed using HOMER is shown in the Figure5-11 (including 5% daily and hourly noise).

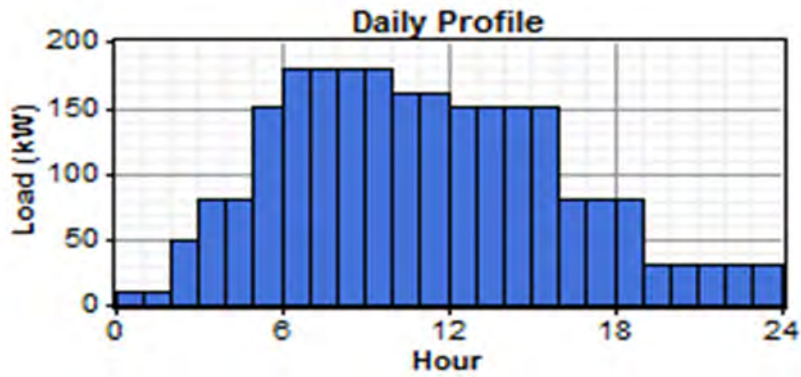
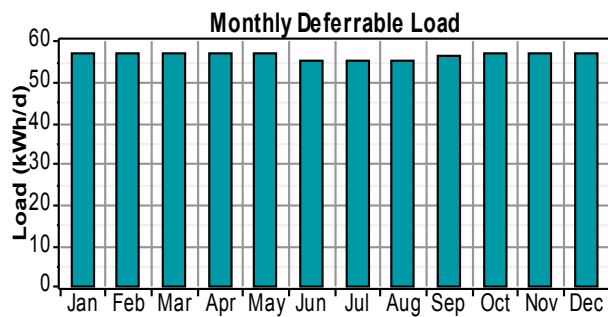

Figure 5-16 Primary load for Deck Island



5-17 Deferrable load for Deck Island

To select appropriate storage and hybrid system here consider two cases

Case 1 when the storage system is battery

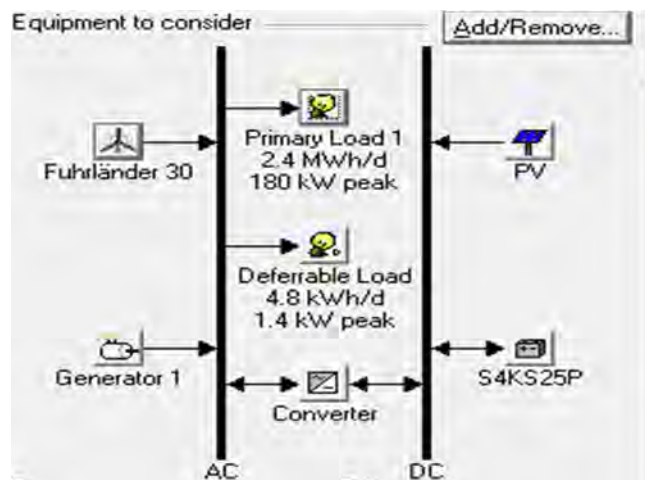

Fig 5.18 Wind/PV/Diesel/Battery hybrid System

Table 5-9 Size and Cost description of Wind/PV/Diesel/Battery hybrid system

	PV Module	Wind turbine	Diesel Generator	Battery BT	Converter
Size (kW)	1	30	0 - 250	1000 Ah	1
Capital (\$)	2200-2400	32000	0 - 37500	833	700
Replacement Cost(\$)	2200-2500	21333	0 - 6000	555	700
O & M cost(\$/yr)	25	50	0.4/hr	15	10
Sizes (kW) considered	0, 5, 10, 15, 20, 25, 30, 35, 40	-----	0, 22, 26, 33, 35, 44, 53, 77	-----	0, 10, 20, 30, 40, 50, 60
Quantities	-----	0, 1, 2, 4, 6, 8, 10, 12, 14, 16, 18, 20	-----	0, 20, 40, 60, 80, 100, 120, 140	-----
Life Time	20 yrs	20 yrs	40000 hrs	15000 kWh	15 yr

Since, the storage capacity for this system is considerably large, so we have to select a special lead-acid battery cell (block type) which are of long life (more than 10 years), high cycling stability (more than 1100times) and standing very deep discharge [17].

The Ampere hour capacity (C_{Ah}) of the block battery, necessary to cover the load demands for a period of 2 days autonomy is obtained as [17]

$$C_{Ah} = \frac{2 * E_L}{V_B * DOD * \eta_B * \eta_V}$$

5.1

Where: - DOD depth of discharge η_B = efficiency of battery

V_B = battery voltage η_V = efficiency of inverter

E_L = Energy consumptions per day

$$C_{Ah} = \frac{2 * 2410 * 1000}{48 * 0.75 * 0.85 * 0.92754} = \frac{2510000}{27.54} = 175018.15Ah$$

And the Watt hour capacity (C_{Wh}) is obtained as :-

$$C_{Wh} = C_{Ah} V_B = 175018.15Ah * 48v = 8400Kwh$$

Case 2 when the storage system pumped micro hydro

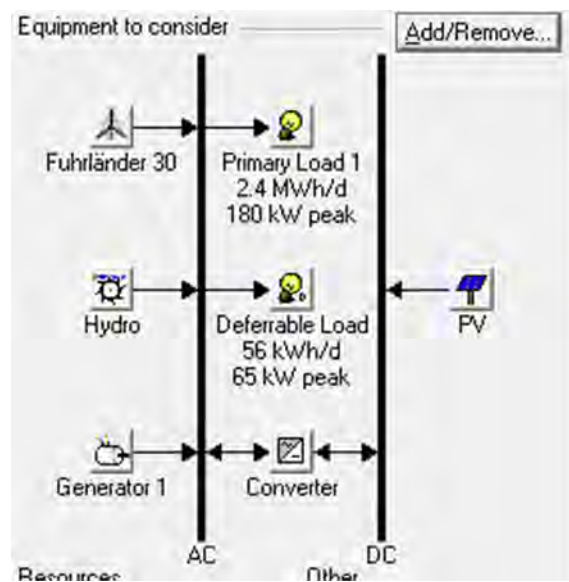

Fig 5-19 Wind/PV/diesel /Pumped hydro hybrid system

Table 5-10 Size and Cost description of Wind/PV/Diesel/Pumped hydro hybrid system

	PV Module	Wind turbine	Diesel Generator	Pumped Hydro storage System	Converter
Size (kW)	1	100	0 - 250	30	1
Capital (\$)	2200-2400	32000	0 - 37500	46000	700
Replacement Cost(\$)	2200-2400	21333	0 - 6000	46000	700
O & M cost(\$/yr)	25	50	0.4/hr	300	10
Sizes (kW) considered	0, 5, 10, 15, 20, 25, 30, 35, 40	-----	0, 22, 26, 33, 35, 44, 53, 77		0, 10, 20, 30, 40, 50, 60
Quantities	-----	0, 1, 2, 4, 6, 8, 10, 12, 14, 16, 18, 20	-----	-----	-----
Life Time	20 yrs	20 yrs	40000 hrs	>25 yrs	15 yr

CHAPTER 6

6. Simulation Results, Conclusions and Recommendations

The feasibility study is carried out in two ways: optimization and sensitivity analysis. The optimization results are given out in an overall form and in a categorized form which represents feasible system configurations capable of meeting the system load and constraints. The results are displayed in an increasing order of the total net present cost (NPC). A given system type may have many different configurations based on the size combination of constituent elements. The categorized table displays only the most cost effective configuration from each system type. The overall optimization table displays all feasible system configurations (for any possible system type) ranked in their cost effectiveness. From the details of the optimization analysis the following can be observed: size of different components in each system, electric production of each component, capital, replacement and operating and maintenance cost of each system, annualized cost, excess and shortage of capacity, cost of energy (COE), renewable fraction, unmet load, amount of emission for each of greenhouse gas, consumption of diesel, operating hour and number of starting of diesel generator, life time of generator and battery, throughput of battery and fuel cost. Renewable fraction cost of energy (COE), unmet load and total NPC values can be used as a parameter of selecting a given configuration among the many candidates.

The sensitivity analysis explains the “what if...” problem for input variables having dynamic nature. It takes the most cost effective system configuration for each combination of sensitivity variable values. Since the price for diesel and for PV panels are more dynamic than other types of components, a range of diesel price (\$1.1/l to \$1.5/l) and a PV capital cost multipliers (0.6 to 1) are used as sensitivity parameters. The PV capital and replacement cost multipliers are linked together. HOMER displays the sensitivity analysis both in tabular and graphical form. For each combination of the sensitivity variables, the sensitivity analysis takes the least cost (ranked 1st) and extrapolates it for the intermediate sensitivity variables. The possibility of other system types can be observed by clicking on the sensitivity graph.

Systems with batteries are observed to have very high COE, low renewable fraction and needs large simulation time corresponding to the large size of components required. Therefore, the simulation and optimization analysis is made to include pumped hydropower systems.

6.1. Results In case of battery storage

In this case renewable energy resources are Wind and PV Sola energy combined with diesel and Battery storage system. The results obtained are based on the current price of diesel (\$1.1/litere) and PV capital of \$2200/kW. From Table 6-1, the levelized COE is observed to be in the range of \$0.186/kWh to \$0.519/kWh. Presence of plenty of renewable resource is indicated by the level of the renewable fraction ranging from 77% to 95% in the renewable fractions column of Tables (6-1 &6-2). Although capacity shortage is allowed to a maximum of 17%, the unmet load is limited to a maximum of 8%.. There are feasible combinations without any diesel generator (a renewable fraction of 100%). It can be seen from the two Tables (6-1 &6-2) that the PV/wind /battery system is better which is followed by PV/wind /diesel /battery system types with increasing total NPC and COE. As shown there detail

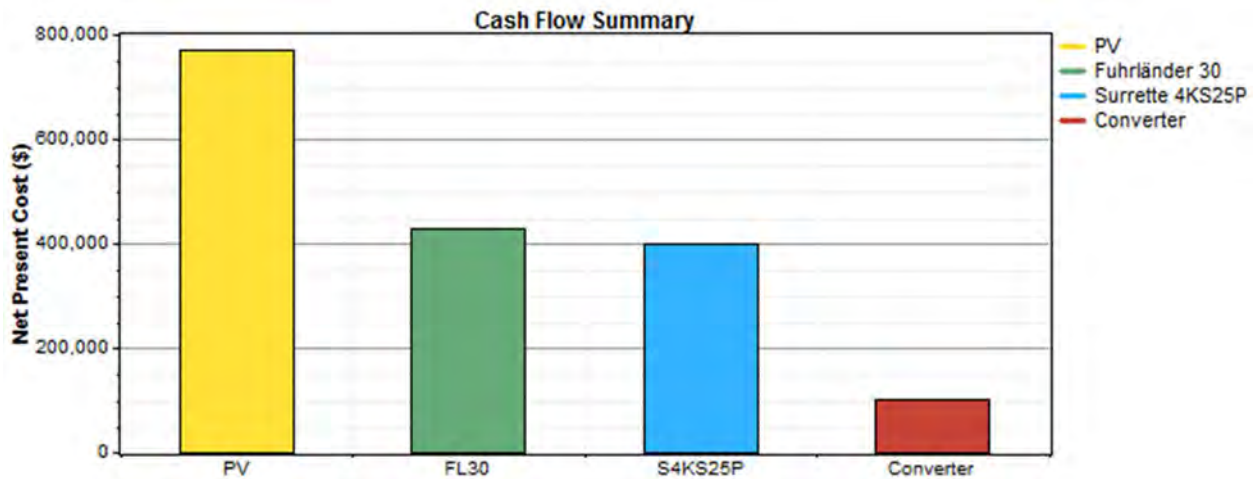

Fig 6.1 Cash flow summary in case of battery storage system

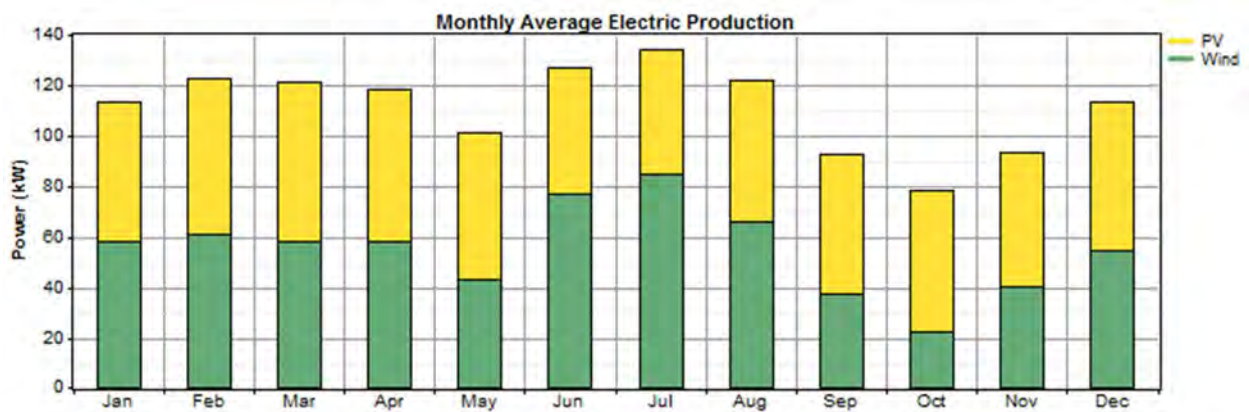

Fig 6-2 Monthly Average electric production in case of Battery storage system

Table 6-1 A optimization results in a categorized format at 2200KW PV cost and \$1.1/litere diesel cost

Rank	PV (kW)	FL30- turbine	Gen (kW)	BT-Battery	Converter (kW)	Total NPC (\$)	COE (\$/kWh)	Renewable fraction	Unmet load fraction	Diesel (L/yr)
1	300	10	-	300	100	1,701,359	0.186	1.00	0.08	-
2	300	10	1	300	100	1,776,818	0.193	0.99	0.08	1,815
3	-	30	-	600	100	2,193,241	0.243	1.00	0.01	-
4	-	30	1	600	100	2,269,813	0.250	0.99	0.01	1,781
5	400	45	1	-	100	3,175,973	0.345	0.99	0.01	1,901
6	400	20	20	600	120	3,987,972	0.454	0.80	0.01	48,139
7	-	45	50	-	120	4,833,873	0.519	0.76	0.01	64,260

Table 6-2 A optimization results in a categorized format at 0.6 PV cost multiplier

Rank	PV (kW)	FL100- turbine	Gen (kW)	BT-Battery	Converter (kW)	Total NPC (\$)	COE (\$/kWh)	Renewable fraction	Unmet load fraction	Diesel (L/yr)
1	300	10	-	300	100	1,437,359	0.157	1.00	0.08	-
2	300	10	1	300	100	1,512,818	0.164	0.99	0.08	1,815
3	--	30	-	600	100	2,193,241	0.243	1.00	0.04	-
4	-	30	1	600	100	2,269,813	0.250	0.99	0.04	1,781
5	400	45	1	-	100	2,823,973	0.307	0.99	0.06	1,901
6	400	20	20	600	120	3,635,972	0.414	0.80	0.03	48,139
7	-	45	50	-	120	4,833,873	0.519	0.76	0.08	64,260

Sensitivity analysis is also carried out using the variation of PV capital cost multiplier against diesel price. At higher price of PV modules wind/PV/diesel/battery systems are chosen with lower and slightly higher price of diesel respectively. As PV module price decrease just PV/wind/ battery system is more economical and the system becomes less sensitive to variation of diesel price.

**Table 6-3 System report for 100% renewable fraction for Case –I
(in case of battery storage system at 2200KW battery cost and \$1.1/litre diesel)**

System architecture		Sensitivity case		Annual electric production (kWh/yr)			Annual electric consumption (kWh/yr)			Emission (kg/yr)	
PV	300 kW	Design flow rate	No	PV array	439,927	51 %	AC primary load	715,703	99% %	CO ₂	0
Wind turbine	Fl-30	Stream flow rate	No	Wind turbine	489,083	49 %	Deferrable load	1,722	1%	CO	0
Gen				Gen							
Battery	300 Block type	wind data	4.67 m/s	Excess electricity	167,277	23.8 4%	Cost summary				
Inverter	10 0kW	PV capital cost multiplier	1	Unmet load	48,928	3.5 %	Total NPC	\$1,701,359		Particulate matter	0
Rectifier	10 0kW			Capacity shortage	41,927	7.9 %	Levelized COE	\$ 0.186/kWh		SO ₂	0
Disp. strategy	CF	Solar data	6.19 kWh/m ² /d	Renewable ratio	1.00	100 %	Operating cost	\$ 31,405/yr		NO _x	0

6.2. Results In case of Pumped hydro storage

In this case the renewables energy resources are Wind, PV hybrid with pumped storage system. The results obtained are based on the current price of diesel (\$1.1/l) and PV capital of \$2200/kW. From Table 6-4, the level zed COE is observed to be in the range of \$0.151kWh to \$0.418/kWh. Presence of plenty of renewable resource is indicated by the level of the renewable fraction ranging from 85% to 100% in the renewable fractions column of Tables 6-4. Although capacity shortage is allowed to a maximum of 10%, the unmet load is limited to a maximum of 9%.. There are feasible combinations without any diesel generator (a renewable fraction of 100%). It can be seen from the two Tables6-4 that the PV/wind /diesel/ pumped storage hydro is better which is followed by wind //pumped hydro system types with increasing total NPC and COE. As shown there detail

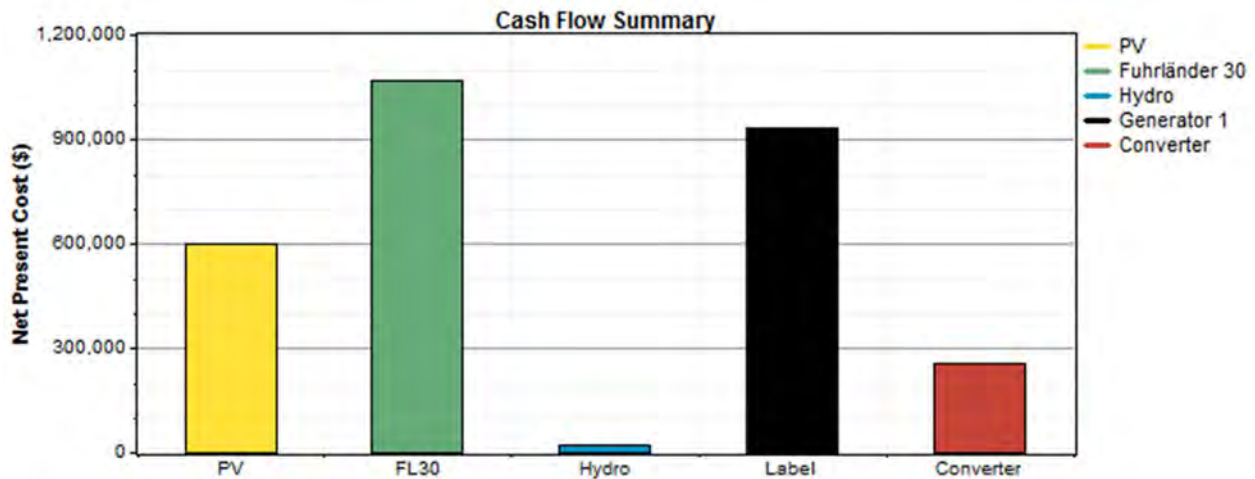

Fig 6.3 Cash flow summary in case of pumped hydro storage system

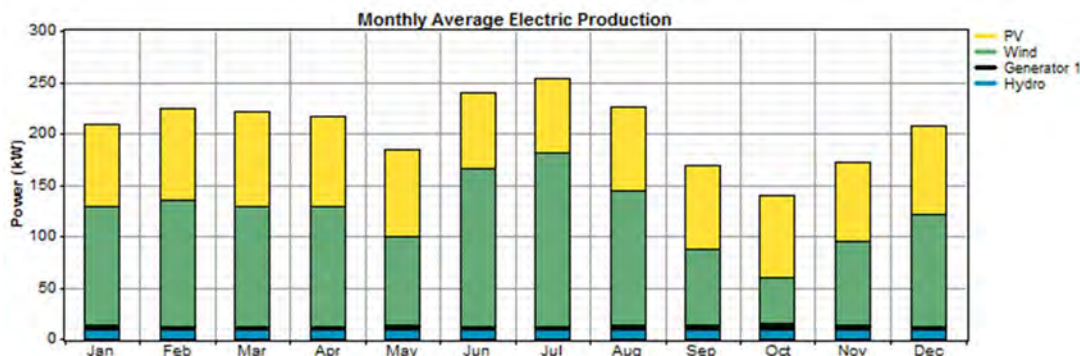

Fig 6.4 Monthly average electric productions in case of pumped storage system

Table 6-4 A optimization results in a categorized format at 2200KW PV cost and \$1.1/litre diesel cost in case of pumped storage system

Rank	PV (kW)	FL-30 turbine	Hydro (kW)	Gen (kW)	Converter (kW)	Total NPC (\$)	COE (\$/kWh)	Renewable fraction	Unmet load fraction	Diesel (L/yr)
1	400	20	30	10	200	2,888,459	0.151	0.95	0.09	4688
2	400	40	30	-	150	2,960,333	0.154	1.0	0.06	-
3	-	60	30	60	-	8,374,711	0.418	0.78	0.04	4471

Table 6-5 A optimization results in a categorized format at 0.6 PV cost multiplier in case of pumped storage system

Rank	PV (kW)	FL-30 turbine	Hydro (kW)	Gen (kW)	Converter (kW)	Total NPC (\$)	COE (\$/kWh)	Renewable fraction	Unmet load fraction	Diesel (L/yr)
1	400	20	30	10	200	2,712,459	0.141	0.95	0.09	4688
2	400	40	30	-	150	2,784,333	0.154	1.0	0.06	-
3	-	60	30	60	-	8,374,711	0.418	0.78	0.04	4471

**Table 6-6 System report for 95% renewable fraction in case of pumped storage system
(at 2200KW PV cost and \$1.1/litre diesel)**

System architecture		Sensitivity case		Annual electric production (kWh/yr)			Annual electric consumption (kWh/yr)			Emission (kg/yr)	
PV	400 kW	Design flow rate	40.8 l/s	PV array	180,698	40 %	AC primary load	746,969	97 %	CO ₂	33,419
Wind turbine	20 FL30 kW	Stream flow rate		Wind turbine	964,100	53 %	Deferrable load	20,584	3%	CO	82.5
Hydro	30.	PV replacement cost multiplier	1	Hydro turbine	80,476	4%	Total	767.553	100 %	Unburned CH ₄	9.14
Gen	10kW	wind data	4.681 m/s	Gen	35,795	2%	Cost summary			Particulate matter	6.22
Battery	20 kW	PV capital cost multiplier	1	Excess electricity	91231.02	18 %	Total NPC	\$2,888,459		SO ₂	67.2
Inverter	20 kW	Solar data	6.19 kWh/m ² /d	Unmet load	1520	0.9 %	Levelized COE	\$ 0.151/kWh		NO _x	737
Rectifier	20 kW	Renewable ratio	0.95	Capacity shortage	14053	2.5 %	Operating cost	\$ 65,218/yr			
Disp. Strategy	cF										

The sensitivity analysis here carried out using the variation PV array capital against diesel price. As indicated in table 6.5 the variation of PV and Diesel price completely change the total NPC and cost of energy.

6.3. Conclusions

In this thesis, feasibility study of renewable energy resources of Small Island for electrification of 725 families (7000 peoples) on Tana Lake in Deck Island is carried out. Wind resource, solar potentials, Pumped storage and community load in the island are analysed. HOMER is used for optimization and sensitivity analysis of different possible hybrid system. Monthly average wind speed data from NASA is used to synthesize hourly wind speed data using HOMER. Solar radiation is calculated from daily sunshine hour data using empirical formulas and is $6.19\text{kWh/m}^2/\text{day}$. This result is very close to what is from NASA predictions. Hourly Primary and Deferrable electric load of the community consisting of lighting, TV set, Refrigerator, radio receiver, Electric mitad, health post, clinic, flour mills water pumps for daily used, water pump for pumped storage system and water pump for irrigated land is determined. The total community (about 725 families) is estimated to have a primary peak demand of 180 kW, a deferrable peak demand of 65 kW and a storage capacity of 1935 kWh. For each site, different optimum and feasible system configurations with different level of renewable fraction and total NPC are obtained. The levelized COE ranges from $\$0.151/\text{kWh}$ to $\$0.418/\text{kWh}$. This cost is slightly higher than the current energy tariff within the country ($< \$0.04/\text{kWh}$), but, is much less than previously studied PV/Diesel hybrid with battery storage system (which does not consider wind and pumped hydro). It can be said that the maximum COE determined here is an acceptable range of energy price in case of Island.

Taking the current diesel price of $\$1.1/\text{l}$ and a PV capital and replacement cost of $\$2200/\text{kW}$, different system configurations/types are found as feasible options. In Case of battery storage system one feasible system from Wind/Diesel/PV/battery is better at lower diesel price and is not sensitive to PV module prices. When diesel price increases slightly, Wind/PV/diesel/battery systems become more favoured at lower PV module price. In Case of Pumped storage system one feasible system from Wind/PV/Diesel/Pumped hydro system become favoured at high wind speed and high PV module price. When PV price is small and Wind speed slow PV/Wind/Diesel/Pumped hydro become more favourite. One sample overall system shows a COE of $\$0.151/\text{kWh}$ and a renewable fraction of 95%. In this system excess electricity of 18% and unmet load of 0.9% have been found. Although the proposed system has a relatively higher COE than the national tariff, in view of the energy shortage at the national level, resistance to deforestation, clean energy development, changing the life of the poor in remote regions and expansion of power generation it is a highly recommendable solution.

Finally I would like to conclude that if there is enough head around the Small Island the pumped storage system is the better solution for storing electrical energy in form of pumped hydro

6.4. Recommendations

Solar radiation measuring equipment's and Wind speed data logger should be installed at selected Island. In addition to what are covered in this thesis, there are other Islands on this Lake even if the people living on island are very small suitable for Eco tourism system which have enough head and near to main land relative to this Island. Currently, the national energy strategy is towards large hydropower, large wind farm and towards geothermal to some extent. Small hydropower developments and its hybrid combination with other sources such as wind and solar is not given attention. Such hybrid systems should be given attention as their capital investment is low and are convenient for rural and Island electrification.

6.5. Suggestions for Future Work

This thesis work may be refined and expanded by considering

1. Exact measured solar radiation, wind speed and other data on island
2. Possible demand growth rate with population and economic growth rate (load forecasting)on island
3. Hybridizing system Solar thermal, biomass together with the current renewable resources
4. Detailed design of each component and steady state and dynamic performance of the overall system.
5. Comparison with Grid extension system through different directions to the main land .

References

- [1]. Breyer Ch., Gerlach A., Hlusiak M., Peters C., Adelman P., Winiacki J., Schützeichel H., Tsegaye S., Gashie W., 2009 “Electrifying the Poor: Highly Economic Off-Grid PV Systems in Ethiopia a Basis for Sustainable Development”
<http://www.arcfinance.org/pdfs/news/EthiopiaPaper2009.pdf>
- [2]. Hadagu A., 2006 “Status and trends of Ethiopian rural Electrification Fund”,
<http://www.bgr.de/geotherm/ArGeoC1/pdf/07%20A.%20Hadagu%20status%20of%20Ethiopian%20Electrification%20fund.pdf>
- [3]. Resource Group (ERG) for Heinrich Boll Foundation (HBF) and Forum for Environment (FfE), 2009, “Diversity and Security for The Ethiopian Power System”, http://www.boell-ethiopia.org/downloads/energy_study.pdf
- [4]. IZURE, Renewable Energy Development Enterprise
- [5]. Japanese Embassy in Ethiopia, 2008 “Study on the Energy Sector in Ethiopia”:
http://www.et.emb-japan.go.jp/electric_report_english.pdf
- [6]. http://www1.eere.energy.gov/solar/ptintable_versions/pv_systems.html (access date: 15/1/2007)
- [7]. <http://www.udel.edu/igert/pvcdrom/CELLOPER/FFH.GIF> (access date : 25/1/2007)
- [8]. Louis Rosenblam, **Practical Aspects of Photovoltaic Technology**, Applications and Cost,
- [9]. Patel, M.R., (2006) *Wind and Solar Power Systems: Design, Analysis, and Operation*. 2nd Ed. Boca Raton: Taylor & Francis Group.
- [10] <http://www.locoengineering.com/images/30W%20I-V.jpg> (access date :30/1/2007)
- [11] Twidell J. And Weir T, 2006, “Renewable Energy Resources”, 2nd Edn, Taylor & Francis,
- [12] Raja A.K., Sristavata P., Dwidevi M., 2006, “Power Plant Engineering”, New Age international, New Delhi, 2006
- [13] World Metrological Organization, 2008 “Manual on Low-Flow Estimation and Prediction”, Operational Hydrology Report No. 50, WMO-NO. 1029
- [14] Design of Small Dams. U.S. Department of Interior. Supt. Of Documents, U. S. Government

Printing Office, Washington DC 20402

- [15] Ponds for Water Supply and Recreation. Agric Handbook No. 387. Soil Conservation Service, USDA “Your Own Water Power Plant”, Popular Science, 1947.Reprinted in issues no. 13 and 14 Mother Earth News.
- [16] “Water Power for Your Home”, Popular Science, May 1977
- [17] Ackermann, T. (2005). *Wind Power in Power Systems*. Chichester: John Wiley & Sons Ltd.
- [18] Pirker, O. (2008) Role of storage and pump storage hydro power plants for grid regulation.2nd Eur electric Small Islands Seminar, 14-15 April 2008, Ajaccio, France.
- [19] Drake F. and, Mulugetta Y., 1996, “Assessment of solar and wind energy in Ethiopia. I. Solar energy”, *Solar Energy*, Vol. 57, No. 3, pp. 205-217, 1996
- [20] Mulugetta Y. and Drake F., 1996, “Assessment of solar and wind energy resources in Ethiopia: II. Wind energy”, *Solar Energy*, Vol. 57, No. 4, pp. 323-334
- [21] Bekele G. and Palm B, 2010, “Feasibility Study for a Standalone Solar-Wind Hybrid Energy System for Application in Ethiopia”, *Applied Energy*, Vol.87, Issue 2, pp. 487–495.
- [22] <http://www.locoengineering.com/images/30W%20I-V.jpg> (access date :30/1/2007)
- [23] Jagstorf B. Renewable Engineering and Development, Brochure to accompany mobile exhibition on renewable engineering in Ethiopia, Factor four Energy projects GmbH
- [24] Gipe, P., (2004) *Wind Power: Renewable Energy for Home, Farm, and Business*. Chelsea Green Publishing Company
- [25] Mathew, s.,(2006) wind energy : fundamentals, Resource Analysis and Economics. Berlin Heidelberg: springer-Verlag
- [26] Kanase-Patil A.B., Saini R.P., Sharma M.P., 2010 “Integrated Renewable Energy Systems for Off Grid Rural Electrification of Remote Area”, *Renewable Energy*, Vol. 35, Issue 6, pp. 1342–1349
- [27] Bakos G.C., 2002 “Feasibility study of a hybrid wind/hydropower-system for low-cost electricity production”, *Applied Energy*, Vol. 72, Issue 3-4, pp. 599–608

[28] Connolly D., Lund H., Mathiesen B.V. and Leahy M., 2010, “A review of computer tools for analysing the integration of renewable energy into various energy systems”, *Applied Energy*, Vol. 87, Issue 4, pp. 1059-1082

[29] M.M. Mahmoud, Individual Applications of Photovoltaic Power Systems, Royal Scientific Society, Amman, Jordan, 1989

[30] Lehner G. , et al, Dynamic behavior of Lead-acid batteries with special respect to PV

[31] HOMER, the Optimization Model for Distributed Power: <http://www.nrel.gov/homer>

Appendixes

1 sample simulation results in case of battery storage system

a) When PV capital cost is 2200Kw and diesel price \$1.1/liter

Sensitivity Results Optimization Results

Sensitivity variables

Diesel Price (\$/L) 1.1 PV Capital Multiplier

Double click on a system below for simulation results.

				PV (kW)	FL30	Label (kW)	S4KS25P	Conv. (kW)	Initial Capital	Operating Cost (\$/yr)	Total NPC	COE (\$/kWh)	Ren. Frac.	Capacity Shortage	Diesel (L)	Label (hrs)
				300	10		300	120	\$ 1,313,900	31,877	\$ 1,721,392	0.183	1.00	0.21		
				300	10	1	300	100	\$ 1,301,400	37,190	\$ 1,776,818	0.193	0.99	0.23	1,815	6,402
				300	10	1	300	120	\$ 1,315,400	38,077	\$ 1,802,154	0.191	0.99	0.21	1,928	6,883
				200	20		300	100	\$ 1,399,900	37,147	\$ 1,874,765	0.197	1.00	0.20		
				200	20		300	120	\$ 1,413,900	37,619	\$ 1,894,798	0.196	1.00	0.19		
				220	20		300	100	\$ 1,443,900	37,719	\$ 1,926,074	0.200	1.00	0.19		
				200	20	1	300	100	\$ 1,401,400	42,317	\$ 1,942,358	0.203	0.99	0.20	1,605	5,764
				60	30		300	100	\$ 1,411,900	41,746	\$ 1,945,553	0.213	1.00	0.24		
				220	20		300	120	\$ 1,457,900	38,191	\$ 1,946,106	0.199	1.00	0.17		
				400	10		300	100	\$ 1,519,900	34,264	\$ 1,957,903	0.206	1.00	0.20		
				200	20	1	300	120	\$ 1,415,400	43,028	\$ 1,965,443	0.203	0.99	0.19	1,663	6,055
				60	30		300	120	\$ 1,425,900	42,218	\$ 1,965,586	0.214	1.00	0.24		
				400	10		300	120	\$ 1,533,900	34,735	\$ 1,977,936	0.200	1.00	0.16		
				40	30	1	300	120	\$ 1,383,400	47,277	\$ 1,987,764	0.220	0.99	0.25	1,711	6,335
				80	20		600	120	\$ 1,399,800	46,057	\$ 1,988,558	0.218	1.00	0.24		
				220	20	1	300	100	\$ 1,445,400	42,678	\$ 1,990,962	0.206	0.99	0.18	1,535	5,541
				80	30		300	100	\$ 1,455,900	42,318	\$ 1,996,862	0.215	1.00	0.23		
				220	10	1	600	120	\$ 1,389,300	48,519	\$ 2,009,537	0.220	0.99	0.24	2,275	7,678
				220	20	1	300	120	\$ 1,459,400	43,427	\$ 2,014,539	0.205	0.99	0.17	1,607	5,870
				60	30	1	300	100	\$ 1,413,400	47,185	\$ 2,016,586	0.220	0.99	0.24	1,661	6,108
				80	30		300	120	\$ 1,469,900	42,790	\$ 2,016,895	0.215	1.00	0.22		
				400	10	1	300	100	\$ 1,521,400	38,852	\$ 2,018,053	0.212	0.99	0.20	1,445	5,089
				100	20		600	100	\$ 1,429,800	46,156	\$ 2,019,835	0.220	1.00	0.24		
				60	30	1	300	120	\$ 1,427,400	47,754	\$ 2,037,863	0.221	0.99	0.23	1,679	6,237
				100	20		600	120	\$ 1,443,800	46,628	\$ 2,039,867	0.218	1.00	0.22		

b) When PV capital cost is 2200Kw X 0.6 multiplier and diesel price \$1.1/liter

Sensitivity Results Optimization Results

Sensitivity variables

Diesel Price (\$/L) 1.1 PV Capital Multiplier 0.6

Double click on a system below for simulation results.

						PV (kW)	FL30	Label (kW)	S4KS25P	Conv. (kW)	Initial Capital	Operating Cost (\$/yr)	Total NPC	COE (\$/kWh)	Ren. Frac.	Capacity Shortage	Diesel (L)	Label (hrs)
						300	10		300	100	\$ 1,035,900	31,405	\$ 1,437,359	0.157	1.00	0.23		
						300	10		300	120	\$ 1,049,900	31,877	\$ 1,457,392	0.155	1.00	0.21		
						300	10	1	300	100	\$ 1,037,400	37,190	\$ 1,512,818	0.164	0.99	0.23	1,815	6,402
						300	10	1	300	120	\$ 1,051,400	38,077	\$ 1,538,153	0.163	0.99	0.21	1,928	6,883
						400	10		300	100	\$ 1,167,900	34,264	\$ 1,605,903	0.169	1.00	0.20		
						400	10		300	120	\$ 1,181,900	34,735	\$ 1,625,936	0.164	1.00	0.16		
						400	10	1	300	100	\$ 1,169,400	38,852	\$ 1,666,053	0.175	0.99	0.20	1,445	5,089
						400	10	1	300	120	\$ 1,183,400	39,900	\$ 1,693,450	0.170	0.99	0.15	1,585	5,791
						200	20		300	100	\$ 1,223,900	37,147	\$ 1,698,765	0.178	1.00	0.20		
						200	20		300	120	\$ 1,237,900	37,619	\$ 1,718,798	0.178	1.00	0.19		
						220	20		300	100	\$ 1,250,300	37,719	\$ 1,732,474	0.180	1.00	0.19		
						400	20		60	120	\$ 1,301,980	34,866	\$ 1,747,685	0.191	1.00	0.24		
						220	20		300	120	\$ 1,264,300	38,191	\$ 1,752,506	0.179	1.00	0.17		
						200	20	1	300	100	\$ 1,225,400	42,317	\$ 1,766,358	0.185	0.99	0.20	1,605	5,764
						200	20	1	300	120	\$ 1,239,400	43,028	\$ 1,789,443	0.184	0.99	0.19	1,663	6,055
						220	20	1	300	100	\$ 1,251,800	42,678	\$ 1,797,362	0.186	0.99	0.18	1,535	5,541
						300	10	5	300	100	\$ 1,043,400	59,361	\$ 1,802,235	0.192	0.97	0.21	8,437	6,312
						220	10	1	600	120	\$ 1,195,700	48,519	\$ 1,815,937	0.199	0.99	0.24	2,275	7,678
						220	20	1	300	120	\$ 1,265,800	43,427	\$ 1,820,939	0.185	0.99	0.17	1,607	5,870
						400	20	1	60	120	\$ 1,303,480	40,628	\$ 1,822,848	0.198	0.99	0.23	1,657	6,623
						300	10		600	100	\$ 1,285,800	43,273	\$ 1,838,972	0.194	1.00	0.20		
						300	10	5	300	120	\$ 1,057,400	61,940	\$ 1,849,203	0.192	0.97	0.18	9,035	6,793
						300	10		600	120	\$ 1,299,800	43,745	\$ 1,859,005	0.189	1.00	0.16		
						300	20		300	100	\$ 1,355,900	40,006	\$ 1,867,309	0.188	1.00	0.16		
						220	10		720	120	\$ 1,294,160	46,205	\$ 1,884,815	0.206	1.00	0.24		

2) Sample simulation results in case of Hydropower system

a) When PV capital cost is 2200Kw and diesel price \$1.1/liter

similarity variables

fuel Price (\$/L) 1.1 PV Capital Multiplier 1

click on a system below for simulation results.

					PV (kW)	FL30	Hydro (kW)	Label (kW)	Conv. (kW)	Initial Capital	Operating Cost (\$/yr)	Total NPC	COE (\$/kWh)	Ren. Frac.	Capacity Shortage	Diesel (L)	Label (hrs)
					400	20	30.0	10	200	\$ 1,258,000	65,218	\$ 2,888,459	0.151	0.95	0.25	12,698	4,688
					400	40	30.0		150	\$ 1,848,000	44,493	\$ 2,960,333	0.154	1.00	0.24		
					500	20	30.0	10	200	\$ 1,368,000	64,048	\$ 2,969,209	0.153	0.96	0.23	11,812	4,329
					500	20	30.0	10	150	\$ 1,333,000	66,252	\$ 2,989,302	0.154	0.95	0.23	12,905	4,766
					400	20	30.0	10	300	\$ 1,328,000	67,585	\$ 3,017,626	0.157	0.95	0.25	12,698	4,688
					400	40	30.0		200	\$ 1,883,000	45,677	\$ 3,024,917	0.157	1.00	0.24		
					400	40	30.0	1	150	\$ 1,849,500	47,623	\$ 3,040,080	0.157	1.00	0.24	1,108	3,943
					500	20	30.0	10	300	\$ 1,438,000	66,415	\$ 3,098,376	0.159	0.96	0.23	11,812	4,329
					400	40	30.0	1	200	\$ 1,884,500	48,651	\$ 3,100,780	0.160	1.00	0.24	1,050	3,758
					500	40	30.0		150	\$ 1,958,000	46,093	\$ 3,110,333	0.160	1.00	0.23		
					400	40	30.0		300	\$ 1,953,000	48,043	\$ 3,154,083	0.164	1.00	0.24		
					500	40	30.0		200	\$ 1,993,000	47,277	\$ 3,174,917	0.163	1.00	0.22		
					500	40	30.0	1	150	\$ 1,959,500	49,107	\$ 3,187,172	0.163	1.00	0.22	1,071	3,791
					400	40	30.0	1	300	\$ 1,954,500	51,018	\$ 3,229,938	0.167	1.00	0.24	1,050	3,758
					500	40	30.0	1	200	\$ 1,994,500	50,057	\$ 3,245,936	0.166	1.00	0.22	988	3,507
					500	40	30.0		300	\$ 2,063,000	49,643	\$ 3,304,083	0.169	1.00	0.22		
					500	40	30.0	1	300	\$ 2,064,500	52,424	\$ 3,375,093	0.172	1.00	0.22	988	3,507
					500	10	30.0	20	200	\$ 1,063,000	101,535	\$ 3,601,375	0.185	0.90	0.22	27,262	5,137
					400	10	30.0	20	200	\$ 953,000	107,067	\$ 3,629,671	0.189	0.89	0.25	29,464	5,608
					300	40	30.0	10	100	\$ 1,718,000	77,244	\$ 3,649,096	0.190	0.95	0.25	12,344	4,511
					300	40	30.0	10	150	\$ 1,753,000	75,880	\$ 3,650,006	0.187	0.96	0.23	11,293	4,233
					300	40	30.0	10	200	\$ 1,788,000	76,657	\$ 3,704,416	0.190	0.96	0.23	11,118	4,190
					400	10	30.0	20	150	\$ 918,000	112,191	\$ 3,722,779	0.194	0.89	0.25	31,389	6,027
					500	10	30.0	20	300	\$ 1,133,000	103,902	\$ 3,730,542	0.191	0.90	0.22	27,262	5,137

b) When PV capital cost is 2200Kw X 0.6 multiplier and diesel price \$1.1/liter

Activity variables

Fuel Price (\$/L) PV Capital Multiplier

Click on a system below for simulation results.

					PV (kW)	FL30	Hydro (kW)	Label (kW)	Conv. (kW)	Initial Capital	Operating Cost (\$/yr)	Total NPC	COE (\$/kWh)	Ren. Frac.	Capacity Shortage	Diesel (L)	Label (hrs)
					400	20	30.0	10	200	\$ 1,082,000	65,218	\$ 2,712,459	0.141	0.95	0.25	12,698	4,688
					500	20	30.0	10	200	\$ 1,148,000	64,048	\$ 2,749,209	0.141	0.96	0.23	11,812	4,329
					500	20	30.0	10	150	\$ 1,113,000	66,252	\$ 2,769,302	0.143	0.95	0.23	12,905	4,766
					400	40	30.0		150	\$ 1,672,000	44,493	\$ 2,784,333	0.145	1.00	0.24		
					400	20	30.0	10	300	\$ 1,152,000	67,585	\$ 2,841,626	0.148	0.95	0.25	12,698	4,688
					400	40	30.0		200	\$ 1,707,000	45,677	\$ 2,848,917	0.148	1.00	0.24		
					400	40	30.0	1	150	\$ 1,673,500	47,623	\$ 2,864,080	0.148	1.00	0.24	1,108	3,943
					500	20	30.0	10	300	\$ 1,218,000	66,415	\$ 2,878,376	0.148	0.96	0.23	11,812	4,329
					500	40	30.0		150	\$ 1,738,000	46,093	\$ 2,890,333	0.149	1.00	0.23		
					400	40	30.0	1	200	\$ 1,708,500	48,651	\$ 2,924,780	0.151	1.00	0.24	1,050	3,758
					500	40	30.0		200	\$ 1,773,000	47,277	\$ 2,954,917	0.151	1.00	0.22		
					500	40	30.0	1	150	\$ 1,739,500	49,107	\$ 2,967,172	0.152	1.00	0.22	1,071	3,791
					400	40	30.0		300	\$ 1,777,000	48,043	\$ 2,978,083	0.154	1.00	0.24		
					500	40	30.0	1	200	\$ 1,774,500	50,057	\$ 3,025,936	0.155	1.00	0.22	988	3,507
					400	40	30.0	1	300	\$ 1,778,500	51,018	\$ 3,053,938	0.158	1.00	0.24	1,050	3,758
					500	40	30.0		300	\$ 1,843,000	49,643	\$ 3,084,083	0.158	1.00	0.22		
					500	40	30.0	1	300	\$ 1,844,500	52,424	\$ 3,155,093	0.161	1.00	0.22	988	3,507
					500	10	30.0	20	200	\$ 843,000	101,535	\$ 3,381,375	0.173	0.90	0.22	27,262	5,137
					400	10	30.0	20	200	\$ 777,000	107,067	\$ 3,453,671	0.180	0.89	0.25	29,464	5,608
					500	10	30.0	20	300	\$ 913,000	103,902	\$ 3,510,542	0.180	0.90	0.22	27,262	5,137
					300	40	30.0	10	100	\$ 1,586,000	77,244	\$ 3,517,096	0.183	0.95	0.25	12,344	4,511
					300	40	30.0	10	150	\$ 1,621,000	75,880	\$ 3,518,006	0.180	0.96	0.23	11,293	4,233
					400	10	30.0	20	150	\$ 742,000	112,191	\$ 3,546,779	0.185	0.89	0.25	31,389	6,027
					500	10	30.0	20	150	\$ 808,000	109,696	\$ 3,550,394	0.182	0.89	0.23	30,057	5,764
					400	40	30.0	10	150	\$ 1,687,000	75,223	\$ 3,567,583	0.180	0.96	0.20	10,555	3,944
					300	40	30.0	10	200	\$ 1,656,000	76,657	\$ 3,572,416	0.183	0.96	0.23	11,118	4,190

