



**ADDIS ABABA UNIVERSITY
ADDIS ABABA INSTITUTE OF TECHNOLOGY
SCHOOL OF ELECTRICAL AND COMPUTER ENGINEERING**

**Power Quality Control of Addis Ababa Light Rail Transit Power Supply
System Using Static VAR Compensator and Harmonic Filter**

A Thesis Submitted to
Addis Ababa Institute of Technology
Addis Ababa University

In Partial Fulfillment of the Requirement for the Degree of Master of
Science in Electrical Engineering (Railway)

By

Desta Tadesse Wolde

Advisor: - Dr. Mengesha Mamo

June, 2016

ADDIS ABABA UNIVERSITY
ADDIS ABABA INSTITUTE OF TECHNOLOGY
SCHOOL OF ELECTRICAL AND COMPUTER ENGINEERING

**Power Quality Control of Addis Ababa Light Rail Transit Power Supply
System Using Static VAR Compensator and Harmonic Filter**

By- Desta Tadesse

APPROVAL BY BOARD OF EXAMINERS

_____	_____	_____
Chairman, School of Graduate Studies	Signature	Date
Dr. Mengesha Mamo	_____	_____
Advisor	Signature	Date
_____	_____	_____
Internal Examiner	Signature	Date
_____	_____	_____
External Examiner	Signature	Date

DECLARATION

I, the undersigned, declare that this thesis is my original work, and has not been presented for a degree in this or any other university, and all sources of materials used for the thesis have been fully acknowledged.

Desta Tadesse

Name

Signature

Addis Ababa

Place

Date of Submission

This thesis has been submitted for examination with my approval as a university advisor.

Dr. Mengesha Mamo

Advisor's

Signature

ABSTRACT

Electric traction systems generate various power quality problems that have a negative impact on its distribution network. Poor power quality affects the performance of the train and introduces a problem in the distribution network. Power quality is the main issues in electrical railway systems.

In this thesis Static VAR Compensator and Harmonic Filters are modeled and simulated using a Matlab/Simulink environment of Addis Ababa Light Rail Transit Systems. The analysis is performed on the St.Yoseph traction substation. The electrical parameters are taken from Addis Ababa Light Rail Transit phase I project of Ethiopian Railway Corporation. Simulation is carried out and results are compared with the Institute of Electrical and Electronics Engineers (IEEE) standard limits.

Static Var Compensator and Harmonic Filter are designed, modeled and simulated using Matlab/Simulink. The simulation result at Point of Common Coupling for train full load shows that a Total Harmonic Distortion is reduced from 16.38% to 0.36% for current and Total Harmonic Distortion is reduced from 6.99% to 0.26% for voltage in worst scenario, which is below 5% limits of Institute of Electrical and Electronics Engineers (IEEE) standard. In addition to that the system power factor is improved from 0.94 to 0.98.

Key Words: Traction Power System, Power Quality, Static Var Compensator, Harmonic Filter, Converters.

ACKNOWLEDGMENT

At first and most, I thank the almighty God for his mercy and grace, which enabled me to complete this work.

I would like express my deepest appreciation and sincere gratitude to my advisor **Dr. Mengesha Mamo**, for his guidance, support, motivation, encouragement and invaluable contribution throughout this thesis work.

Also I am deeply thankful to **Ethiopian Railway Corporation** for sponsoring me this master program.

I would also special thanks should go to my friends who gave me their help and time in listening to me and helping me work out my problems during the difficult course of the thesis.

Finally, I would thank my wife **Tigist Yimer** for her constant encouragement, and my daughter **Soliyana Desta** who suffered some alienation and negligence during the course of this work.

PQ Control of AALRT Power Supply System using SVC & Harmonic Filter

Contents

ABSTRACT.....	i
ACKNOWLEDGMENT.....	ii
LIST OF FIGURES.....	v
LIST OF TABLES.....	vi
LIST OF ACRONYMS AND ABBREVIATIONS	vii
CHAPTER ONE	1
INTRODUCTION.....	1
1.1. Motivation and Background	1
1.2. Statement of the Problem	2
1.3. Objectives	3
1.3.1. General Objectives	3
1.3.2. Specific Objectives.....	3
1.4. Methodology	4
1.5. Literature Review.....	4
1.6. Organization of the Thesis	5
CHAPTER TWO	6
POWER QUALITY IN ELECTRIFIED RAILWAY SYSTEMS	6
2.1. Introduction	6
2.2. Definition of Power Quality (PQ).....	7
2.3. Power Quality Problem in Electrified Railway	9
2.3.1. Voltage Unbalance	10
2.3.2. Voltage Flicker	10
2.3.3. Voltage Fluctuation	11
2.3.4. Harmonic Distortion	13
2.4. Power Factor, Distortion Factor, and Total Power Factor	15
2.5. Power System Harmonics Sources	16
2.6. Effects of Harmonics on Power System Components	18
2.7. Harmonics of Traction Converters.....	20
2.8. Harmonic Mitigation Techniques	25

PQ Control of AALRT Power Supply System using SVC & Harmonic Filter

2.9. Power Quality Monitoring	30
2.10.Static VAR Compensator and Harmonic Filter	30
2.10.1.Static VAR Compensator.....	30
2.10.2.Harmonic Filter	36
CHAPTER THREE	37
MODELING OF COMPONENTS	37
3.1. Introduction	37
3.2. Distribution line Modeling	38
3.3. Rectifier Substation Modeling	41
3.4. Traction load (Train) Model	45
3.5. The SVC Model.....	47
3.6. Harmonic Filter Design	49
CHAPTER FOUR	53
SIMULATION RESULTS AND DISCUSSION.....	53
4.1. Simulation of Traction Power Supply System without SVC and Harmonic Filter	54
4.2. Simulation of Traction Power Supply System with SVC and Harmonic Filter	58
CHAPTER FIVE	63
CONCLUSION AND RECOMMENDATION	63
5.1. Conclusion.....	63
5.2. Recommendation	63
REFERENCES.....	64
Appendix A: Parameter Determination	66
Appendix B: IEEE 519-1992 Power Quality Standards.....	68

LIST OF FIGURES

Figure 2. 1 Voltage fluctuation	12
Figure 2. 2 Schematic of a simple power distribution network	17
Figure 2. 3 Basic circuit diagram of 12-pulse diode rectifier for different arrangement	21
Figure 2. 4 Circuit diagram of six pulse diode rectifier	21
Figure 2. 5 Circuit diagram of six pulse diode rectifier	26
Figure 2. 6 Common shunt passive filter configuration.....	26
Figure 2. 7 Low pass broadband filters configurations (a): LL type, (b): LLCL type	27
Figure 2. 8 12-pulse rectifier system configuration	28
Figure 2. 9 Active filter fundamental system configurations:.....	29
Figure 2. 10 Hybrid active filters common configurations:	29
Figure 2. 11 Single-line diagram of typical SVC configuration.	31
Figure 2. 12 Circuit diagram of TCR.....	33
Figure 2. 13 Circuit diagram of TSC	35
Figure 3. 1 Equivalent circuit of three phase Pi-circuit model [19].....	38
Figure 3. 2 Spatial status of between two train stations.....	40
Figure 3. 3 Speed characteristic of the train sets with time variation	41
Figure 3. 4 Equivalent circuit of three winding transformer.....	42
Figure 3. 5 12- pulse diode rectifier circuits	42
Figure 3. 6 Simplified model of rectifier circuit	44
Figure 3. 7 Equivalent circuits of harmonic components on the DC and AC side	44
Figure 3. 8 Traction load block diagram.....	45
Figure 3. 9 SVC System.....	48
Figure 3. 10 Simple connection diagram of single tuned filter.....	49
Figure 4. 1 Block diagram of electrical network model without SVC and harmonic filter	55
Figure 4. 2 AC voltage and current waveforms at PCC, without SVC & harmonic filter	56
Figure 4. 3 AC voltage and current harmonic spectrum at PCC, with SVC and harmonic filter	57
Figure 4. 4 Block diagram of electrical network model without SVC and harmonic filter.....	58
Figure 4. 5 AC voltage and current wave form at PCC, without SVC & harmonic filter	59
Figure 4. 6 AC voltage and current harmonic spectrum at PCC, with SVC and harmonic filter	59
Figure 4. 7 Load current without SVC and harmonic filter	60
Figure 4.8 Load current with SVC and harmonic filter	60

LIST OF TABLES

Table 2.1 Power quality phenomena..... 8
Table 2.2 System voltage variation limits..... 12
Table 4. 1 Simulation parameters 53
Table 4. 2 Total harmonic distortion level before compensated..... 61
Table 4. 3 Total harmonic distortion level after compensated..... 61
Table 4. 4 comparisons of THD of voltage and current simulation result at PCC without and with SVC
and Harmonic mitigation 62
Table B. 1 Current distortion limits for general distribution systems (120 V through 69 KV)... 68
Table B. 2 Shows the IEEE 519-1992 recommended voltage distortion limits 68

LIST OF ACRONYMS AND ABBREVIATIONS

AA LRT	Addis Ababa Light Rail Transit
AC	Alternating Current
C	Capacitor
DC	Direct Current
FACTS	Flexible AC Transmission System
Hz	Herze
HSCB	High Speed Circuit Breaker
IEEE	Institute of Electrical and Electronics Engineers
LRT	Light Rail Transit
Km	Kilo Meter
KV	Kilo –Volt
L	Inductance
MATLAB	Matrix Laboratory
MVA	Mega Volt ampere
NPS	Negative Phase Sequence
OCS	Overhead Contact System
PQ	Power Quality
PCC	Point of Common Coupling
Pf	Power factor
PWM	Pulse Width Modulation
Q_f	Quality factor
R	Resistance
RES	Electrified Railway Systems
RMS	Root Mean Square
STF	Single Tuned Filter
SVC	Static Var Compensator
TDD	Total Demand Distortion
THD	Total Harmonic Distortion

PQ Control of AALRT Power Supply System using SVC & Harmonic Filter

TCR	Thyristor Controlled Reactor
TSC	Thyristor Switched Capacitor
V	Volts
Var	Volt-ampere reactive
VVVF	Variable Voltage Variable Frequency
α	Firing angle

CHAPTER ONE

INTRODUCTION

1.1. Motivation and Background

Electrified railway systems (RES) are essential for the transport of people and goods. The traction electrification system shall supply sufficient power to transit vehicles to provide safe, efficient, and continuous operations of the transit system. The operation of electrified railway lines depends on the stability and reliability of the power distribution at the traction power supply system. Operation of traction vehicle may cause significant effect on power quality parameters in the power supply systems. Voltage and current waveforms in the railway system directly depend on the type of traction vehicle, its characteristics and electrical properties.

Electrical railway systems are considered one of the main public transportation systems. These systems have power quality problems which can adversely affect other consumers and equipment in Point of Common Coupling (PCC). The quality of the electric power supplied is also very important for the efficient functioning of the end user equipment.

Electric traction systems generate various power quality problems that have an impact on its distribution network. The connection of DC light rail transit power supply systems to AC transmission and distribution networks gives rise to a number of power quality issues at PCC.

The electric railway needs a power supply that the trains can access at all times. It must be safe, economical and user friendly.

Traction power supply system of AALRT have adapted the mode of power supply by DC 750V overhead contact system and return current along the running rail. An AC power supply is transformed and rectified to provide the DC traction voltage, connected to substation's bus bars. Each substation includes one or more transformers, each feeding its own rectifier. The rectifier output is connected between the overhead catenary system, and the running rail. The

traction sub-network, which transforms the 15KV voltage into 750V DC by means of rectifier substation and which distributes this 750V voltage for power supply of the train.

The power quality problem such as voltage fluctuation, voltage and current distortion, voltage sags, voltage transient, and voltage and current unbalances will result in extra line losses, under voltage at the terminal of contact wire and unbalanced current of utility grid. The degree of the problem depends on the feeding electric railway traction loads including behavior of the trains, electric locomotive speed profile and power supply scheme. These problems present huge impact to the utility grid.

In this thesis work power quality problem created by power converters in railway traction system of Addis Ababa Light Rail Transit (AALRT) is studied. The performance of the system under different load condition is analyzed.

1.2. Statement of the Problem

An electric railway system has a number of advantages in terms of traffic capacity, operational cost and environmental friendliness in comparison with other transportation system. With the increased use of sophisticated electronics, high efficiency variable speed drive, and power electronic controller, power quality has become an increasing concern to utilities and customers.

DC traction systems generate various power quality problems that have an impact on its distribution network. The main problem to the power distribution of traction network is caused by the rectifier substation, which is an additional component in the DC electric traction system. It produces waveform distortions and consequent harmonic generation.

Harmonic in a system can cause equipment malfunction, power loss, overheating of neutral buses, tripping of circuit breakers, data distortion, transformer and motor insulation failure and solid-state component breakdown.

The power system interface of DC feeder systems is limited to some harmonics injected to power system at substations that can be attenuated by appropriate filters. Naturally, power

PQ Control of AALRT Power Supply System using SVC & Harmonic Filter

quality affects the systems reliability because of its incidence on hazard rate of components, misoperation of signaling systems, and degradation of system performance.

Power quality phenomena involved in the interaction between the railways electrical systems and the power distribution systems are voltage fluctuation, voltage and current distortion, voltage sags, voltage transient, and voltage and current unbalances.

The two primary impacts of power quality issues on a distribution networks are the potential for equipment operation to be adversely affected by the power quality problem and the reduction in power factor caused by certain types of harmonics.

The operational behavior of power electronics devices are non-linear, as a result the harmonic is introduced to the system. These harmonics have effects on the linearity of the supply power from the utility grid which leads to the degradation of the system performance.

Power quality problem, not only harm the traction system itself, but also prone to spreading through the supply grid, distributing other power users in the same grid. Therefore a means for solving the power quality problem is must. In this thesis Static VAR compensator and harmonic filter are designed to solve the power quality problem in electrified railway traction power supply system.

1.3. Objectives

1.3.1. General Objectives

The main objective of this thesis is to study the non-linear loads power quality problem for Addis Ababa LRT phase I traction power system using Matlab/Simulink Software and introduce corrective solution to mitigate the power quality problems and investigating the advantages of inserting SVC and Harmonic filter to traction power supply system.

1.3.2. Specific Objectives

The specific objectives of this thesis are:

- ❖ Identify causes of power quality problem

- ❖ Identify section of AALRT which is the most prone to power quality problems
- ❖ Analyze the effects of electric traction system on power quality
- ❖ Improve the power factor of the system
- ❖ Compare the performance of the system with and without the proposed solution.

1.4. Methodology

In order to achieve the desired objective of this thesis work

- ❖ Reviewing different literatures where the theoretical information regarding the power quality problem is gathered and comparison of previous similar research is studied.
- ❖ Collecting data which are essential for this thesis work. This is followed by studying the characteristic and modeling of traction power system components.
- ❖ Simulating the modeled components using MAT LAB/ simpower toolbox
- ❖ Performance comparison, Analysis and Interpretation of the results

1.5. Literature Review

In recent years, Railway engineers pay more attention to power quality of traction power supply systems.

Rekha T, Dr.Bisharathu Beevi A [1] presented a paper on compensation devices, SVC and Harmonic filter for practical DC electric traction networks to improve the voltage and reduce wave distortion. In this paper he discussed different power quality phenomena that can appear such as voltage fluctuation, voltage and current distortion, voltage sag, voltage transient, voltage and current unbalances. All of the power quality phenomena appear due to the presences of non-linear loads. Also he analyzed the system and the power quality problems generated different scenarios.

S.H. Hosseini, F.Shahnia, M.Sarhangzadeh, E.Babaei [2], proposed hybrid filter structure with new and simple control techniques is used for power quality improvement of the DC distribution system feeding the DC electrified railway systems. In this paper he is discussed the efficiency of the proposed hybrid filter structure for reducing the current harmonics, voltage and current balancing, reactive power compensation and power factor improvement.

Mridula Sharma, Manish Soni [14], presented a paper on power quality issues for traction system. This paper provide framework for issue like harmonics, voltage sag, voltage unbalance, poor power factor and flicker which cause poor power quality.

In this thesis work propose integration of Static Var Compensator and Harmonic Filter in the Rectifier traction substation for improving power quality. The power quality analysis is performed using Matlab/ Simulink environment.

1.6. Organization of the Thesis

The work carried out in this thesis has been summarized in five chapters.

Chapter one includes introduction which provides clear information about the thesis work motivation and background, statement of the problem, objectives and methodology of the thesis, literature review and outline of the thesis.

The second chapter generally covers about theoretical background of the study topic, mainly on power quality problem of electrified railway system, power system harmonic sources, effect of harmonics on power system components, harmonics in traction converters, harmonic mitigation techniques, SVC and harmonic filter.

The third chapter outlines modeling of subsystems. In this chapter the distribution line, Rectifier substation, traction load, SVC and harmonic filter are modeled.

Simulation results and discussions are put in the fourth chapter of this thesis work. Proposed solution to the power quality enhancement and traction network power quality improvement problems and the appropriate simulations are discussed in detail.

Conclusions and recommendations are incorporated under chapter five.

CHAPTER TWO

POWER QUALITY IN ELECTRIFIED RAILWAY SYSTEMS

2.1. Introduction

In recent years, power quality (PQ) issue has become more critical because of the increase the number of loads sensitive to power disturbances, and as the loads themselves have become major causes of the degradation of power quality.

Electric traction systems generate various power quality problems that have an impact on the distribution network. Traction power supply system creates power quality problems to the grid in which is connected resulting poor power quality and also increases the operational cost due to less productivity and damages of sensitive equipment in other nearby facility. The continuous increase in traffic demand of traction systems makes it difficult to maintain the power quality. At the same time it becomes essential to minimize the issues like harmonics, voltage sags and flicker to protect sensitive equipment affected by the aforementioned issue produced by traction systems.

Power quality is important because electronic devices and appliances have been designed to receive power at or near these voltage and frequency parameters, and deviations may cause appliance malfunction or damage.

Power quality has been given attention due to wide application of power converter for controlling and converting AC power to feed electrical loads. The power converters or non-linear load will cause a low power factor efficiency of the power system, implies to voltage distortion, and increases losses in the transmission and distribution line.

There are three major reasons for the increased concern on PQ:

1. Newer-generation load equipment with microprocessor-based control and power electronic devices is more sensitive to power quality variations than was equipment used in the past.

PQ Control of AALRT Power Supply System using SVC & Harmonic Filter

2. Power system efficiency has resulted in continued growth in the application of devices such as adjustable-speed motor drives and shunt capacitors for power factor correction to reduce losses.
3. Many things are now interconnected in a network. Integrated processes mean that the failure of any component has much more important consequences.

2.2. Definition of Power Quality (PQ)

The Institute of Electrical and Electronic Engineers (IEEE) standard IEEE 1100 describes the power quality as “The concept of powering and grounding electronic equipment in a manner that is suitable to the operation of that equipment and compatible with the premise wiring system and other connected equipment.”

A simpler and perhaps more concise definition might state: “Power quality is a set of electrical boundaries that allows a piece of equipment to function in its intended manner without significant loss of performance or life expectancy.”

Power quality is a combination of current quality and voltage quality, involving the interaction between the system and the load. Voltage quality concerns the deviation of the voltage waveform from the ideal sinusoidal voltage of constant magnitude and constant frequency. Current quality is a complementary term and it concerns the deviation of the current waveform from the ideal sinusoidal current of constant magnitude and constant frequency. Voltage quality involves the performance of the power system towards the load, while current quality involves behavior of the load towards the power systems.

Power quality (PQ) is ultimately a consumer-driven issue we define power quality as any power problem manifested in voltage, current, or frequency deviation that result in failure or misoperation of customer equipment. Any significant deviation in the waveform magnitude, frequency, or purity is a potential power quality problem.

Poor power Quality generally mean there is sufficient deviation in the electrical power supply to cause equipment/ process misoperation or failure.

PQ Control of AALRT Power Supply System using SVC & Harmonic Filter

Good Power Quality means that the electrical power supply is sufficient for the equipment/process to operate satisfactorily.

PQ disturbances can be broadly classified in to two categories as follows:

Variations

A characteristic of voltage or current which is never exactly equal to its nominal or desire value.

Events

Significant deviations of voltage or current from its nominal or ideal wave shape.

Variations are monitored continuously over a period of time; whereas events are monitored using a triggering mechanism which records the desired property once set value is exceeded.

The different types of power quality problems are summarized in Table 2.1

Table 2.1: Power quality phenomena

Category	Specific Type
Events	Transients
	Interruption
	Sag
	Swell
	Phase Angle Jump
Variations	Magnitude Variation
	Frequency Variation
	Phase Variation
	Unbalance
	Flicker
	Harmonic Distortion
	Inter-Harmonics
	Notching
	Noise

2.3. Power Quality Problem in Electrified Railway

The growing complexity of the electrified Railway Systems in terms of both new technologies and automation requires a careful control of the power quality disturbances. The disturbances depend on the traction system structure.

The DC traction systems can produce:

- ❖ Voltage and current distortions, due to the AC/DC static converters of the traction substations;
- ❖ Slow voltage variations, due to the time-varying nature of phase powers.

In the three-phase power supply network.

Inadequate power quality is indicated if one or more of the following occur frequently in a system.

- ❖ Changes in amplitude of AC voltage. This can be either for short period or for long period. Such changes can take the form of:
 - Voltage variations such as sag and swell and repeated voltage fluctuations
 - Surges or transient sub-cycle disturbances
 - Interruption (an extreme form of amplitude change)
 - Noise
- ❖ Frequency disturbances produced from the generating sources, which can be a utility grid, or a stand-alone power source such as an emergency engine generator.
- ❖ Waveform asymmetry, which may cause the voltage vectors of the three phases to be different in values and the phase angle shift to vary from the normal value of 120 electrical degrees.
- ❖ Change in the AC voltage waveform appearing as harmonics.

2.3.1. Voltage Unbalance

Voltage unbalance (imbalance) is defined as the ratio of a negative- or- zero- sequence component to a positive-sequence component. The negative- or- zero- sequence voltages in a power system generally result from unbalanced loads causing negative or zero sequence currents to flow. The voltage imbalance in a power system is due to single-phase loads. In particular, single-phase traction loads connected across different phases produce negative-phase-sequence voltages, which in many cases have to be reduced to less than 2% with the help of SVCs.

Electrified trains are single phase loads inherently, connection of these time varying unbalance loads to three phase power system will lead to huge power unbalance. The degree of voltage and current unbalances depends of the train motion, load condition and power supply configuration [25].

The unbalances affect the operation of the supply system and of various equipments connected to it. The induction motors, fed by an unbalanced system of voltages, present lower efficiency, overheats and increase the real power losses, so a significant loss of the life duration. The voltage unbalance produces also high frequency pulsation torques and consequently vibrations and noises during operation. Voltage unbalance may also cause the undesired tripping of relays, influences converters and PWM drives operation due to the amplitude or phase angle unbalance. The capacitor banks, connected to power system with unbalance voltages contribute itself to the aggravation of the unbalance. In fact, on the phase with the smallest phase voltage amplitude, the smallest reactive power is associated and so the smallest improvement of the power factor [25].

2.3.2. Voltage Flicker

Voltage Flickers are short duration voltage changes, resulting from switching, Short circuits and load changing.

The traction power demand on utility system is rapidly changes as trains accelerate and decelerate, as they encounter track gradients, and as they enter and leave catenary feeding sections. The quick variation of traction current results in sudden variation of voltage at the substation connection point and to a lesser degree, on other utility bus bars. As the traction power

substations are generally connected to a high voltage utility system, the available fault level will generally be sufficiently high to avoid undesirable effects due to voltage flicker. The current flowing in traction power supply equipment cause pulsating forces which can be significant magnitude, and therefore, can be potentially harmful to substation equipment.

The severity of the problem depends on the utility system fault level at the substation connection point, the magnitude of the load fluctuation from instant to instant, and frequency of the fluctuations.

2.3.3. Voltage Fluctuation

Voltage fluctuations are short duration variations in voltage levels due to change in, or switching of loads within the supply network. Voltage fluctuations are mainly caused by rapid and repetitive variation of traction loads. The voltage waveform exhibits variations in magnitude due to the fluctuating nature or intermittent operation of connected loads.

Voltage fluctuations are rapid changes in voltage within the allowable limits of voltage magnitude of 0.95 to 1.05 of the nominal voltage. The voltage fluctuation is a series of voltage changes or a cyclical variation of the voltage envelope.

The instantaneous voltage, $v(t)$, can be expressed as

$$V(t) = V_p [1 + m \sin(2\pi f_m t)] \cos(2\pi \omega_o t) \quad (2.1)$$

Where V_p =the amplitude (nominal) of the fundamental ac voltage

ω_o = the fundamental frequency,

f_m = the modulation frequency

$m = \frac{\Delta v}{2V_p}$ the modulation depth and

Δv = the magnitude of voltage fluctuation

PQ Control of AALRT Power Supply System using SVC & Harmonic Filter

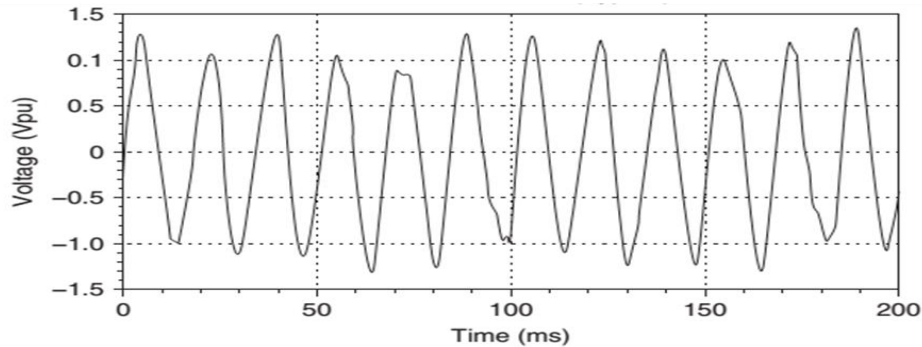

Figure 2.1: Voltage fluctuation

In DC electrified systems a step change of the current may then occur only for a switching-off of load current. In normal conditions this event happens when the current is lesser than the maximum current of the locomotive so that the rapid voltage change is not critical. The step change of the current may occur when the traction power demanded by the train is the maximum. It can be observed that the disturbance is basically dependent on the short circuit level as for the voltage unbalance.

When considering in the phenomena that affect power quality the effect of particular waveform features on system loads is important. The feature may not be the same as those that disturb public electricity systems. Traction systems are subject to significant load changes giving rise to frequent voltage fluctuation of up to and beyond 5%. While a frequent 5% voltage fluctuation would be unacceptable to public electricity supplies, traction vehicles are immunized to deal with voltage change and they do not experience significant disturbance.

Table 2.2: System voltage variation limits

Definition of Operating system voltage	15KV
$U_{\min 2}$ lowest non permanent voltage duration 10 min	11KV
$U_{\min 1}$ lowest non permanent voltage duration indefinitely	12KV
U_n nominal voltage designed system value	15KV
$U_{\max 1}$ highest permanent voltage duration indefinitely voltage designed system value	17.25 KV
$U_{\max 2}$ highest non permanent voltage duration indefinitely voltage designed system value	18KV

2.3.4. Harmonic Distortion

Harmonics are sinusoidal voltages or currents having frequencies that are whole multiples of the frequency at which the supply system is designed to operate. When the frequencies of these voltages or currents are not an integral multiple of the fundamental they are termed inter-harmonics. Both harmonic and inter-harmonic distortion is generally caused by equipment with non-linear voltage/ current characteristics.

When non-linear loads are connected to the electrical grid, the current that flows through the lines contains harmonics, and the resulting voltage drops caused by the harmonics on the lines impedances causes distortion on the feeding voltages.

Most non-linear loads as well as loads controlled by the power electronics systems are harmonic source. Fluorescent lighting and AC/DC converters in power electronic system are typical example in point. All electricity companies are concerned about harmonic pollution, especially from large non-linear loads such as railway system connected to their power system network.

Electrical train having thyristors or PWM controlled converters injects harmonic current into the feeding overhead lines. Harmonic currents in the electric train are one of the biggest concerns, and the load current model to represent electric trains is proposed. The current harmonics injected from an ac electric train propagate through power-feeding circuits. Being a distributed RLC circuit, the feeding circuit can experience parallel resonance at a specific frequency. The harmonic current is simplified by the resonance, and the amplified harmonic current usually induces various problems, including interference in adjacent communication lines and the railway signaling system, overheating, and vibration at the power capacitors, and erroneous operation at protective devices.

Harmonic voltage distortion in traction systems may rise to levels which are 2 or 3 times higher than those normally accepted in public utility systems. Harmonic voltage is a response by parallel resonant paths in traction supply network to sudden step changes in the locomotive waveform.

PQ Control of AALRT Power Supply System using SVC & Harmonic Filter

Distortion in the voltage waveform is characterized by total harmonic distortion, THD_v , which is defined as root mean square (RMS) of harmonics expressed as a percentage of the fundamental component as given in (2.2)

$$THD_v = \frac{\sqrt{\sum_{h=2}^{\infty} V_h^2}}{V_1} \times 100\% \quad (2.2)$$

Where; V_h = the RMS voltage of the h^{th} harmonic component

V_1 = the RMS voltage of the fundamental component and

h_{max} = the highest harmonic order of interest

Similarly, the current total harmonic distortion can be defined as (2.3)

$$THD_i = \frac{\sqrt{\sum_{h=2}^{\infty} I_h^2}}{I_1} \times 100\% \quad (2.3)$$

Where; I_h = the RMS current of the h^{th} harmonic component and

I_1 = the RMS current of the fundamental component

In the case of harmonic currents, fundamental current may fall to a value close to zero under certain circumstances, resulting in large values for THD_i . Hence, the distortion in the current waveform is generally characterized by total demand distortion, TDD_i , which is defined as the RMS of the current harmonics expressed as a percentage of the RMS load current. The general expression of TDD for harmonic current is given in (Eq. 2.3)

$$TDD_i = \frac{\sqrt{\sum_{h=2}^{\infty} I_h^2}}{I_L} \times 100\% \quad (2.4)$$

Where, I_h = the RMS current of the h^{th} harmonic component and

I_L = the RMS load current

2.4. Power Factor, Distortion Factor, and Total Power Factor

For sinusoidal voltages and currents, the power factor is defined as KW/KVA and the power factor angle ϕ is [26]

$$\phi = \cos^{-1} \left(\frac{KW}{KVA} \right) = \tan^{-1} \left(\frac{Kvar}{KW} \right) \quad (2.5)$$

The power factor in presence of harmonics comprises two power factors; the displacement power factor and the distortion power factor. The displacement power factor is the ratio of active power of the fundamental wave in watts to apparent power of fundamental wave in volt-amperes. The distortion power factor is the distortion component associated with the harmonic voltages and currents. For harmonic generating loads, the total power factor will always be less than the displacement power factor.

In the case of nonlinear load or when the source has nonsinusoidal waveform. The apparent power can be defined as:

$$S = \sqrt{P^2 + Q^2 + D^2} \quad (2.6)$$

Where,

S is apparent power

P is the active power

Q is the reactive power

D is the distortion power

The active power, P can be defined as

$$P = \sum_{h=1}^{\infty} V_h I_h \cos(\theta_h - \delta_h) \quad (2.7)$$

Where,

V_h and I_h are in rms values

Q can be written as

$$Q = \sum_{h=1}^{\infty} V_h I_h \sin(\theta_h - \delta_h) \quad (2.8)$$

From equation 2.6, the distortion power, D, can be written as

$$D^2 = S^2 - (P^2 + Q^2) \quad (2.9)$$

The total power factor is

$$Pf = \cos \phi = \frac{P}{S}$$

$$Pf = \cos(\phi_1) \frac{1}{\sqrt{1+TDH_1^2}} \quad (2.10)$$

Where,

$\cos(\phi_1)$ = displacement power factor Pf_{disp} because it depends of the phase angle between the voltage and the fundamental component of the current.

$\frac{1}{\sqrt{1+TDH_1^2}}$ = distortion power factor Pf_{dist} because it depends of the current harmonic distortion.

The power factor calculated as the product of the displacement power factor and the distortion power factor is known as Total Power Factor (Pf_T).

$$Pf_T = Pf_{disp} * Pf_{dist}$$

2.5. Power System Harmonics Sources

The characteristic of non-linear loads is that they draw a distorted current waveform even though the supply voltage is sinusoidal. Most equipment only produces odd harmonics but some devices have fluctuating power consumption, from half cycle to half cycle or shorter, which then generates odd, even and inter-harmonic currents. The current distortion, for each device, changes due to the consumption of active power, background voltage distortion and changes in source impedance.

PQ Control of AALRT Power Supply System using SVC & Harmonic Filter

A simple structure of power network consisting of a non-linear load and some other loads, all connected to the PCC. The PCC is typically a point of metering. There is some flexibility in determining the PCC, but in most instances, it is the point at which the high voltage side of a customer transformer is connected to the distribution network.

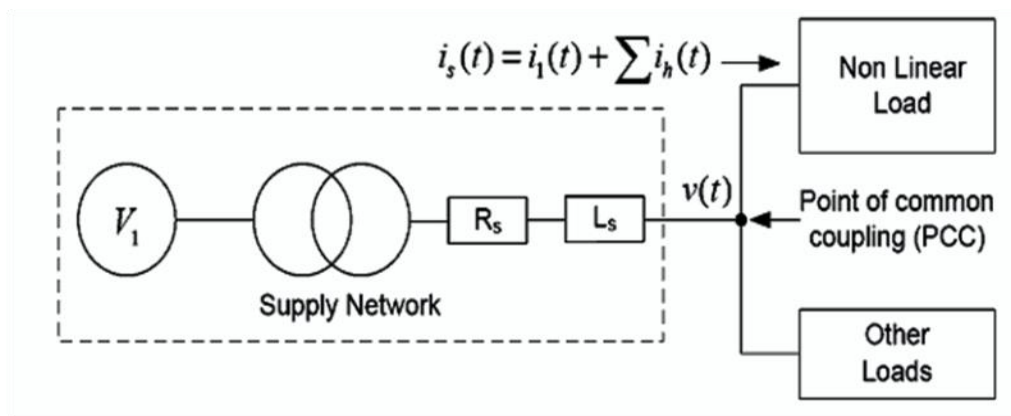

Figure 2.2: Schematic of a simple power distribution network

The non-linear load current $i_s(t)$ consists of the fundamental component and harmonics. The non-linear load produces harmonic current flow in the supply network, which reacts with the network impedance (R_s , L_s) to create voltage drop along this impedance. Therefore, the voltage at the PCC is distorted and no longer sinusoidal even if V_1 is sinusoidal. Any other loads, even linear loads, connected to the PCC therefore have harmonic currents injected into them by the distorted PCC voltage. Such currents are referred to as contributions from the power system, or supply harmonics.

In general, major harmonic sources can be categorized as:

- ❖ Devices that generate harmonics during their switching processes;

Three-phase power electronic devices play a significant role in generating harmonics. The most commonly seen are power electronic devices, such as static converters that are often used in traction system, HVDC links and motor drives [20]. These devices are sensitive to supply voltage distortion and unbalance.

- ❖ Devices that generate harmonics due to their nonlinear voltage-current characteristics; Typical harmonic sources of this category are transformers, reactors, AC arc furnaces, and fluorescent lamps with electromagnetic ballasts. Harmonic generated from transformers and reactors occur when the core flux enters the saturated region of the magnetization curve driven by over-excitation [20].
- ❖ Hybrid devices that include both types of aforementioned devices; For this category of harmonic sources, it consists of DC arc furnaces and fluorescent lamps with electronic ballasts. The harmonics produced by a DC arc furnace concentrates at orders of $(6k+1)$. $K= 0, 1, 2 \dots$ However inter-harmonics are also generated due to the stochastic nature of the arc. In general, these harmonics are of all orders with even harmonics being of small magnitudes [20].
- ❖ Rotating machines with non-sinusoidal flux distribution. The harmonic sources of this category mainly include synchronous machines and induction motors.

2.6. Effects of Harmonics on Power System Components

The effect of current distortion on power distribution systems can be serious, primarily because of the increased current flowing in the system. There are many bad effects of harmonics on power system components. These bad effects can derated the power system component. The main detrimental effects of harmonics are:

Effects of harmonics in Transformers and Reactors

- ❖ The eddy current losses increase in proportion to the square of the load current and square of harmonic frequency
- ❖ The hysteresis losses will increase
- ❖ The loading capacity is derated by harmonic currents and
- ❖ possible resonance may occur between transformer inductance and line capacitor

Effects of harmonics in Capacitor

- ❖ The life expectancy decreases due to increased dielectric losses that cause additional heating, reactive power increase due to harmonic voltages, and
- ❖ Overvoltage can occur and resonance may occur resulting in harmonic magnification.

Effects of harmonics in Cables

- ❖ Additional heating occurs in cables due to harmonic currents because of skin and proximity effects which are function of frequency, and
- ❖ The I^2R losses increase.

Effects of harmonics in Motors

- ❖ Stator and rotor I^2R losses increase due to the flow of harmonic currents,
- ❖ In the case of induction motors with skewed rotors the flux changes in both the stator and rotor and high frequency can produce substantial iron losses, and
- ❖ Positive sequence harmonics develop shaft torque that aid shaft rotation; negative sequence harmonics have opposite effect.

Effects of harmonics in Electronic Equipment

- ❖ Unstable operation of firing circuits based on zero voltage crossing.
- ❖ Erroneous operation in measurement equipment, and
- ❖ Malfunction of computer allied equipment due to presence of AC supply harmonics.

2.7. Harmonics of Traction Converters

Urban DC traction systems using 12-pulse wave rectifiers generates large amount of the dominant harmonics which are 11th and 13th harmonics, and for AC systems, trains use AC/DC/AC converters causing different harmonics flowing into the three-phase power system.

In traction power system the power conversion is done at the rectifier substation. The main equipment of the rectifier substation is a rectifier or converter unit. A six-pulse and twelve-pulse rectifiers with a three phase input supply systems are commonly used rectifiers in traction systems. Six-pulse converters are fed by two winding three phase transformer while the twelve-pulse converters are supplied power with three winding transformers with two secondary displaced by 30°. IN this section the operational principle of twelve-pulse rectifier with the analysis of its harmonic current and voltage waveform is to be covered.

Twelve-pulse Diode Rectifier

There are two combinations of six-pulse diode rectifiers, series and parallel, to form a twelve-pulse rectifier. A typical example of twelve-pulse rectifier is given in figure 2.3

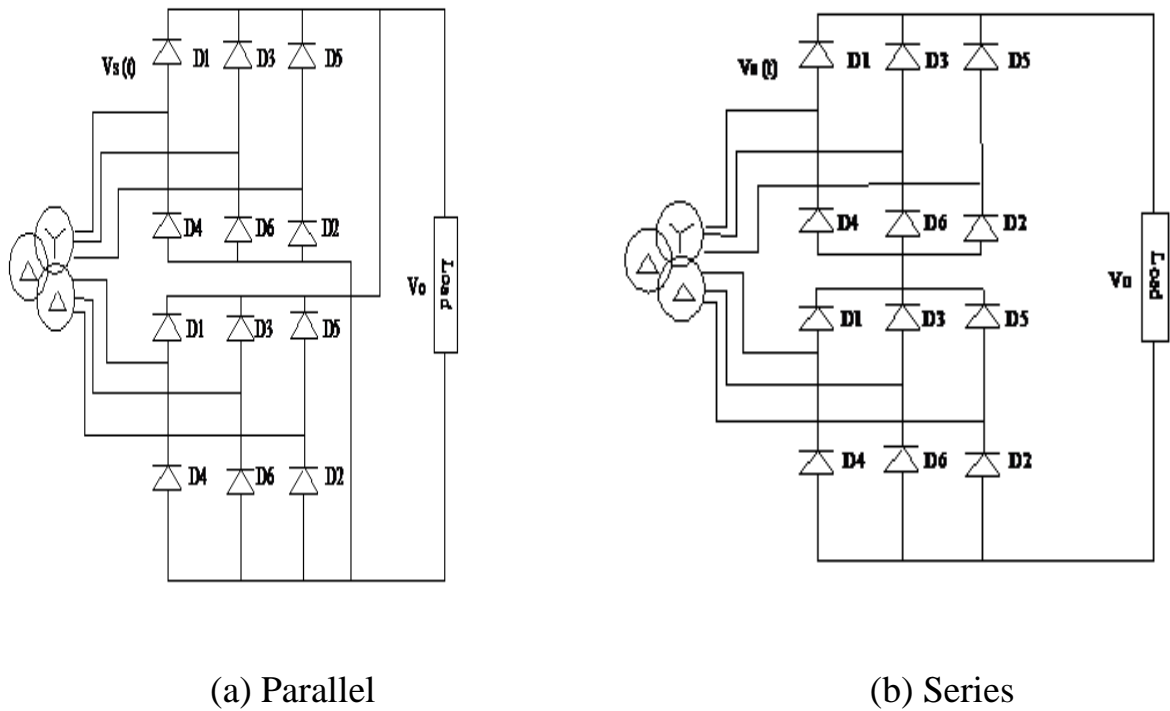

Figure 2.3: Basic circuit diagram of 12-pulse diode rectifier for different arrangement

The parallel combination of two 6-pulse diode rectifiers gives in a 12-pulse rectifier with smoothed output waveform. The advantage of the 12-pulse rectifier is reduction in the AC input line current harmonics and DC output voltage ripple.

The output voltage and input current waveform can be calculated using 6-pulse rectifier waveforms.

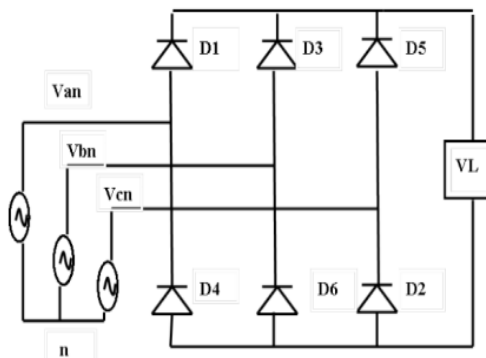

Figure 2.4: Circuit diagram of six pulse diode rectifier

PQ Control of AALRT Power Supply System using SVC & Harmonic Filter

The output voltage and current waveform of 6-pulse rectifier, figure 2.4 a given as follows,

The line-to neutral three phase voltages are given below

$$V_{an} = V_m \sin \omega t$$

$$V_{bn} = V_m \sin \left(\omega t - \frac{2\pi}{3} \right) \quad (2.11)$$

$$V_{cn} = V_m \sin \left(\omega t + \frac{2\pi}{3} \right)$$

The corresponding line-to-line voltages will be:

$$V_{ab} = V_{an} - V_{bn} = \sqrt{3} V_m \sin \left(\omega t + \frac{\pi}{6} \right)$$

$$V_{bc} = V_{bn} - V_{cn} = \sqrt{3} V_m \sin \left(\omega t - \frac{\pi}{2} \right) \quad (2.12)$$

$$V_{ca} = V_{cn} - V_{an} = \sqrt{3} V_m \sin \left(\omega t + \frac{5\pi}{6} \right)$$

Using the Fourier series expansion the output voltage waveform can be expressed in trigonometric forms as;

$$V_o = V_{dc} + \sum_{n=6,12,18,..}^{\infty} a_n \cos(n\omega t) + \sum_{n=6,12,18,..}^{\infty} b_n \sin(n\omega t) \quad (2.13)$$

Where the average output voltage is found from:

$$V_{dc} = \frac{1}{T} \int_0^T V_{ab} d\omega t = \frac{3}{\pi} \int_{\frac{\pi}{6}}^{\frac{\pi}{2}} (\sqrt{3} V_m \sin \left(\omega t + \frac{\pi}{6} \right)) d\omega t = \frac{3\sqrt{3}}{\pi} V_m \quad (2.14)$$

The RMS value of the output voltage is:

$$V_{rms} = \sqrt{\frac{3}{\pi} \int_{\frac{\pi}{6}}^{\frac{\pi}{2}} V_{ab}^2 d\omega t} = \sqrt{3} V_m \left(\sqrt{\frac{1}{2} + \frac{3\sqrt{3}}{4\pi}} \right) = 1.6554 V_m \quad (2.15)$$

The Fourier series coefficient is calculated as:

$$a_n = \frac{2}{T} \int_0^T V_{ab} \cos(n\omega t) d\omega t = \frac{6}{\pi} \int_{\frac{\pi}{6}}^{\frac{\pi}{2}} (\sqrt{3} V_m \sin \left(\omega t + \frac{\pi}{6} \right)) \cos(n\omega t) d\omega t$$

$$= \frac{6\sqrt{3}}{\pi} V_m \left(\frac{1}{n^2 - 1} \right) \quad (2.16)$$

$$b_n = \frac{2}{T} \int_0^T V_{ab} \sin n\omega t \, d\omega t = \frac{6}{\pi} \int_{\frac{\pi}{6}}^{\frac{\pi}{2}} (\sqrt{3} V_m \sin(\omega t + \frac{\pi}{6})) \sin(n\omega t) \, d\omega t = 0 \quad (2.17)$$

Using equation (2.5), (2.7) and (2.8), the output voltage waveform is:

$$V_o = \frac{3\sqrt{3}}{\pi} V_m + \frac{6\sqrt{3}}{\pi} V_m \sum_{n=6,12,18,\dots}^{\infty} \frac{1}{(n^2 - 1)} \cos(n\omega t)$$

$$V_o = \frac{3\sqrt{3}}{\pi} V_m + \frac{6\sqrt{3}}{35\pi} V_m \cos 6\omega t + \frac{6\sqrt{3}}{143\pi} V_m \cos 12\omega t + \frac{6\sqrt{3}}{323\pi} V_m \cos 18\omega t + \dots \quad (2.18)$$

So, output voltage of 6-pulse rectifier has harmonic components of integral multiple of 6th harmonics.

Similarly, the input phase current I_a can be expressed in terms of a Fourier series by replacing I_o with its average value for simplification purpose. This approximation will be valid provided that the ripple on I_o is small, i.e., the load is highly inductive. The modified input current waveform will then be I_a

$$I_a = \frac{I_{dc}}{2} + \sum_{n=1}^{\infty} a_n \cos(n\omega t) + \sum_{n=1}^{\infty} b_n \sin(n\omega t) \quad (2.19)$$

Where the coefficients are determined as follows;

$$I_{dc} = \frac{1}{T} \int_0^T I_a \, d\omega t = \frac{1}{2\pi} \int_0^{2\pi} I_a \, d\omega t = 0 \quad (2.20)$$

$$a_n = \frac{2}{T} \int_0^T I_a \cos(n\omega t) \, d\omega t = \frac{1}{\pi} \int_0^{2\pi} I_a \cos(n\omega t) \, d\omega t$$

$$= (-1)^k \frac{2\sqrt{3}}{(6k \pm 1)\pi} I_o \sin\left(6\pi \pm \frac{\pi}{2}\right), \text{ for } n=6k \pm 1, k=1,2,3,\dots \quad (2.21)$$

$$b_n = \frac{2}{T} \int_0^T I_a \sin(n\omega t) \, d\omega t = \frac{1}{\pi} \int_0^{2\pi} I_a \sin(n\omega t) \, d\omega t = 0 \quad (2.22)$$

$$\therefore I_a = \sum_{k=1}^{\infty} \frac{2\sqrt{3}}{(6k \pm 1)\pi} I_o \sin\left(6\pi \pm \frac{\pi}{2}\right) \cos((6k \pm 1)\omega t)$$

PQ Control of AALRT Power Supply System using SVC & Harmonic Filter

$$I_a = \frac{2\sqrt{3}}{\pi} I_o \left(\cos \omega t - \frac{1}{5} \cos 5\omega t + \frac{1}{7} \cos 7\omega t - \frac{1}{11} \cos 11\omega t + \frac{1}{13} \cos 13\omega t - \frac{1}{17} \cos 17\omega t + \dots \right) \quad (2.23)$$

The output voltage waveform of 12-pulse rectifier, figure 2.3 a given as follows,

$$V_{o\Delta} = \frac{3\sqrt{3}}{\pi} V_m + \frac{6\sqrt{3}}{35\pi} V_m \cos 6\omega t + \frac{6\sqrt{3}}{143\pi} V_m \cos 12\omega t + \frac{6\sqrt{3}}{323\pi} V_m \cos 18\omega t + \dots \quad (2.24)$$

$$V_{oy} = \frac{3\sqrt{3}}{\pi} V_m + \frac{6\sqrt{3}}{35\pi} V_m (\cos 6\omega t - 30^\circ) + \frac{6\sqrt{3}}{143\pi} V_m (\cos 12\omega t - 30^\circ) + \frac{6\sqrt{3}}{323\pi} V_m (\cos 18\omega t - 30^\circ) + \dots \quad (2.25)$$

The output voltage of the 12-pulse rectifier is approximated by the average of the two 6-pulse rectifier output voltage.

$$V_o = \frac{V_{o\Delta} + V_{oy}}{2}$$

$$V_o = \frac{3\sqrt{3}}{\pi} V_m + \frac{6\sqrt{3}}{35\pi} V_m \cos (12\omega t) + \frac{6\sqrt{3}}{143\pi} V_m \cos (24\omega t) + \frac{6\sqrt{3}}{323\pi} V_m \cos (36\omega t) + \dots \quad (2.26)$$

The AC line current is given as follows:

$$I_{a\Delta} = \frac{2\sqrt{3}}{\pi} I_o \left(\cos \omega t + \frac{1}{5} \cos 5\omega t - \frac{1}{7} \cos 7\omega t - \frac{1}{11} \cos 11\omega t + \frac{1}{13} \cos 13\omega t + \frac{1}{17} \cos 17\omega t + \dots \right) \quad (2.27)$$

$$I_{ay} = \frac{2\sqrt{3}}{\pi} I_o \left(\cos \omega t - \frac{1}{5} \cos 5\omega t + \frac{1}{7} \cos 7\omega t - \frac{1}{11} \cos 11\omega t + \frac{1}{13} \cos 13\omega t - \frac{1}{17} \cos 17\omega t + \dots \right) \quad (2.28)$$

$$I_a = I_{a\Delta} + I_{ay}$$

$$= \frac{4\sqrt{3}}{\pi} I_o \left(\cos \omega t - \frac{1}{11} \cos 11\omega t + \frac{1}{13} \cos 13\omega t - \frac{1}{23} \cos 23\omega t + \dots \right) \quad (2.29)$$

2.8. Harmonic Mitigation Techniques

Various harmonic reduction techniques have been developed to meet the requirements of imposed by the current harmonic standards. In general these techniques can be classified into four broad categories:

1. Passive filter (line reactors and/or DC link chokes, series, shunt, and low pass filters)
2. Phase multiplication systems (12-pulse rectifier systems)
3. Active harmonic compensation systems (series, parallel)
4. Hybrid systems

The intent of these techniques is to make the input current a pure sinusoidal waveform, so as to reduce the overall current THD. In passive filters, the flow of the undesired harmonics currents into the power system can be prevented by the usage of a high series impedance to block them or by diverting them to a low impedance shunt path. These two methods represent the series and the shunt passive filters, respectively [21].

A passive filter is built from passive network elements, i.e. resistor, capacitor and inductors. There are two approaches to suppress undesired harmonic currents using passive filters. The series harmonic filter uses series impedance to block harmonic currents while the shunt filter acts as harmonic current sink and diverts harmonic currents by providing low impedance shunt path.

AC line reactor filter and DC link inductor filter are two purely inductive type filters. AC line reactors offer a considerable magnitude of inductance that alter the way the current is draw by the rectifier bridge. They make the current waveform less discontinuous, resulting in lower current harmonics. To maximize the input reactance while minimizing AC voltage drops both AC line reactors and DC link inductance, shown in figure 2.5 can be combined. The DC link inductance is electrically present after the diode rectifier and before the DC bus capacitor and it perform very similar to the three phase AC line reactors. Both AC line and DC link inductance insertion methods provide a limited amount of THD reduction that is not sufficient to comply with the IEEE 519 standards.

PQ Control of AALRT Power Supply System using SVC & Harmonic Filter

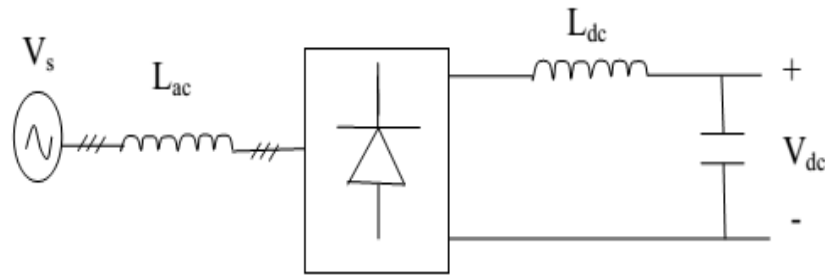

Figure 2.5: Circuit diagram of six pulse diode rectifier

Shunt filters are invariably used in power systems to reduce harmonics voltages to acceptable levels at the PCC. A shunt filter offers very low impedance path at the frequency to which it is tuned and it shunts most of the harmonic current at the frequency. Most common shunt filter types are the single tuned and high pass filters. These two filters are relatively simple to design and implement among other shunt types. The layout of common shunt filter types is shown in figure 2.6.

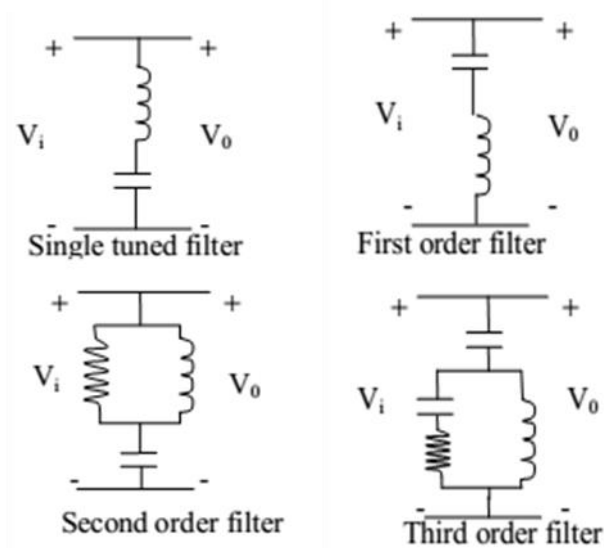

Figure 2.6: Common shunt passive filter configuration

Unlike the shunt and series filters that have a narrow band of harmonic suppression broadband filters have a wider range of harmonic suppression property. Broadband filters employ a combination of two passive techniques, with a high series impedance to block the undesired

PQ Control of AALRT Power Supply System using SVC & Harmonic Filter

current harmonics (from flowing through the grid) and a low shunt impedance path to divert their flow through the shunt filter. They can be different structures, shown in figure 2.7 (a) and (b), LC and LLCL type. They are tuned to a low cutoff frequency such that only fundamental component will pass from the input to the output. Therefore, they are called low pass broadband filters. Both shown low pass broadband filters use only one shunt filter to suppress all the harmonic broadband. On the contrary, classical shunt filters are tuned to a single harmonic frequency to be suppressed and multiple stages are used to suppress all injected current harmonics.

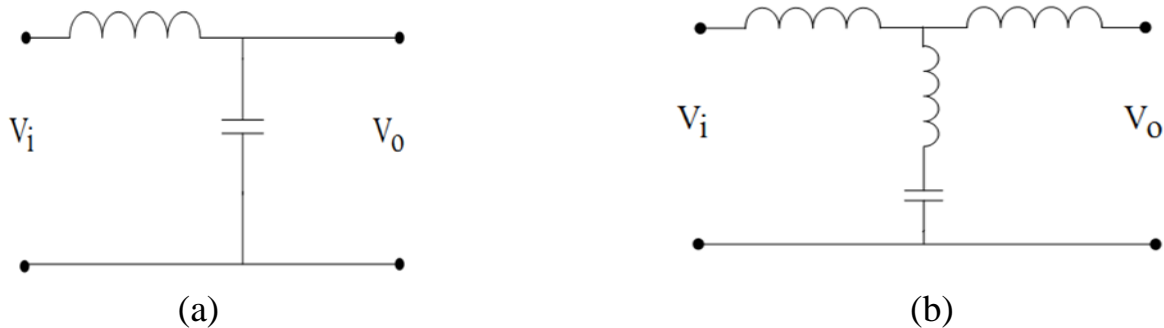

Figure 2.7: Low pass broadband filters configurations (a): LL type, (b): LLCL type

Phase multiplication techniques are based on increasing the pulse number for the converter. This increases the lowest harmonic order for the converter and reduces the size of the passive filter needed to filter out the current harmonics. A 12-pulse converter ideally has the lowest harmonic order of 11 (5th and 7th current harmonics are theoretically nonexistent). However, a 12-pulse converter, shown in fig. 2.8, needs two 6-pulse bridges and two sets of 30^o phase shift AC inputs. Many different topologies exist for the phase shift achievement. In general, the phase multiplication technique is effective to reduce low order current harmonics as long as there is a balanced load on each of the converter.

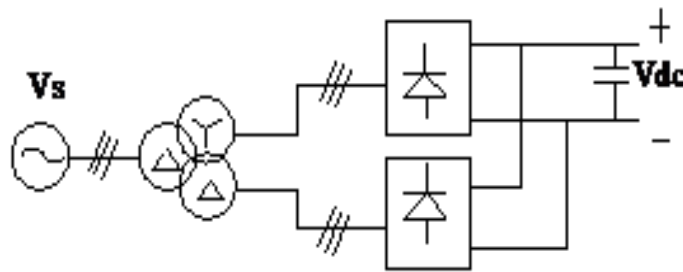

Figure 2.8: 12-pulse rectifier system configuration

Active filters give good system performance and harmonic current reduction. However, they are based on sophisticated power electronics components and thus they are much more expensive than passive filters. In active filters the basic idea is to inject to the line equal magnitudes of the current/ voltage harmonics generated by the non-linear load and with 180 degrees phase angle difference so they cancel each other.

Active filter can be classified based on converter type, topology, and number of phases. The converter type can be either voltage source Inverter (VSI) or current source Inverter (CSI). The topology can be shunt, series, or a combination of both. The third classification is based on the number of phases, such as two-wire (single-phase) and three- or four-wire (three-phase) systems. Of all various configurations, parallel active filter using the VSI topology accompanied by high performance current regulations methods is the most frequently employed type. For harmonic compensation, the parallel active filter employs the instantaneous reactive power theory or synchronous frame transformation based compensation techniques. Active filters of many configurations have been introduced and improved. Shown in figure 2.9, are the fundamental configurations.

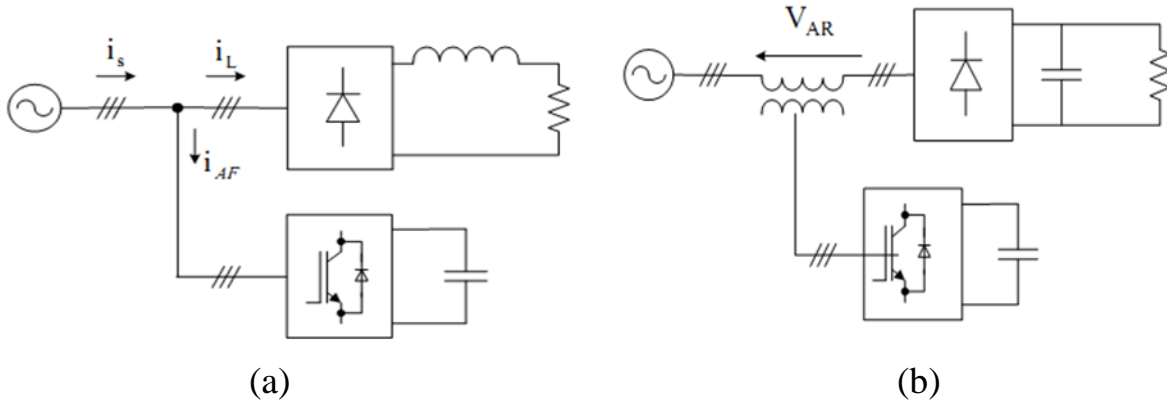

Figure 2.9: Active filter fundamental system configurations:

- (a) Shunt active filter,
- (b) Series active filter.

Hybrid active filters, as shown in figure 2.9, combine active and passive filters in various configurations. The main purpose of hybrid active filters is to reduce initial costs and to improve efficiency. They are also used to improve the compensation characteristics of passive filters and alleviate any series or parallel resonance due to supply or load respectively practically, more viable and cost effective hybrid filter topologies have been developed than stand-alone active filters. Usually, with shunt passive filter combinations, the passive filter is tuned up to a specific frequency to suppress the corresponding harmonic and decrease the power rating of active filter.

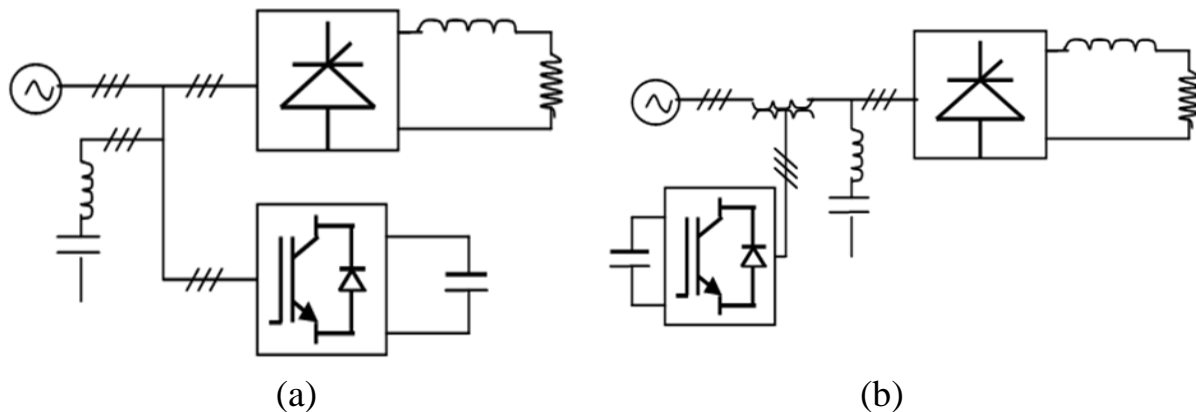

Figure 2.10: Hybrid active filters common configurations:

- (a) Shunt active filter and shunt passive filter,
- (b) Series active filter and shunt passive filter

2.9. Power Quality Monitoring

Power quality monitoring is a process that is based on gathering of information regarding the performance of the system in terms of voltage and current harmonics, the obtained information are usually compared with standards of IEEE 519 to evaluate the influence of these events. IEEE 519 attempts to establish reasonable harmonic goal for electrical systems that contain non-linear loads. The objective is to proposed steady state harmonic limits that are considered reasonable by both electric utilities and their customers.

Harmonic analysis in general can benefit from monitoring. The collected waveforms of voltage and current are also used to test protection and control algorithms of power quality meters play an important role in the monitoring process.

2.10. Static VAR Compensator and Harmonic Filter

2.10.1. Static VAR Compensator

The Institute of Electrical and Electronic Engineers (IEEE) defines the Static var compensator (SVC) is “a shunt connected static var generator or absorber whose output is adjusted to exchange capacitive or inductive current so as to maintain or control specific parameters of the electrical power system.”

The SVC is a fast –acting power electronic device used for dynamic control of voltage in a local area or at an interface point.

Static var compensators (SVCs) are primarily used in power systems for voltage control or for improving system stability.

The SVC is an automated impedance matching device, designed to bring the system closer to unity power factor. SVCs are used in two main situations:

- ❖ To regulate the transmission voltage (“Transmission SVC”)
- ❖ To improve power quality (“Industrial SVC”)

PQ Control of AALRT Power Supply System using SVC & Harmonic Filter

The SVC is comprises one or more banks of fixed switched shunt capacitors or reactors, of which at least one bank is switched by thyristors. Elements which may be used to make SVC typically include:

- ❖ Thyristor Controlled Reactor (TCR)
- ❖ Thyristor Switched Capacitor (TSC)
- ❖ Harmonic Filter
- ❖ Mechanically switched capacitors or reactors.

The SVC can also be used as load balancer to compensate the Negative Phase Sequence (NPS) caused by the unbalanced load (catenary). The filter circuit of the SVC system is designed to absorb harmonic generated by trains as well as Thyristor Controlled Reactor (TCR). The total harmonic distortion and individual harmonic voltages are limited. One of the applications of SVCs is to balance a single phase loads such as traction loads, so that the negative sequence voltage at the PCC is within the limits set by the respective national standards. The SVC uses closed loop control system to regulate bus bar voltage, reactive power exchange, power factor and three phase voltage balance.

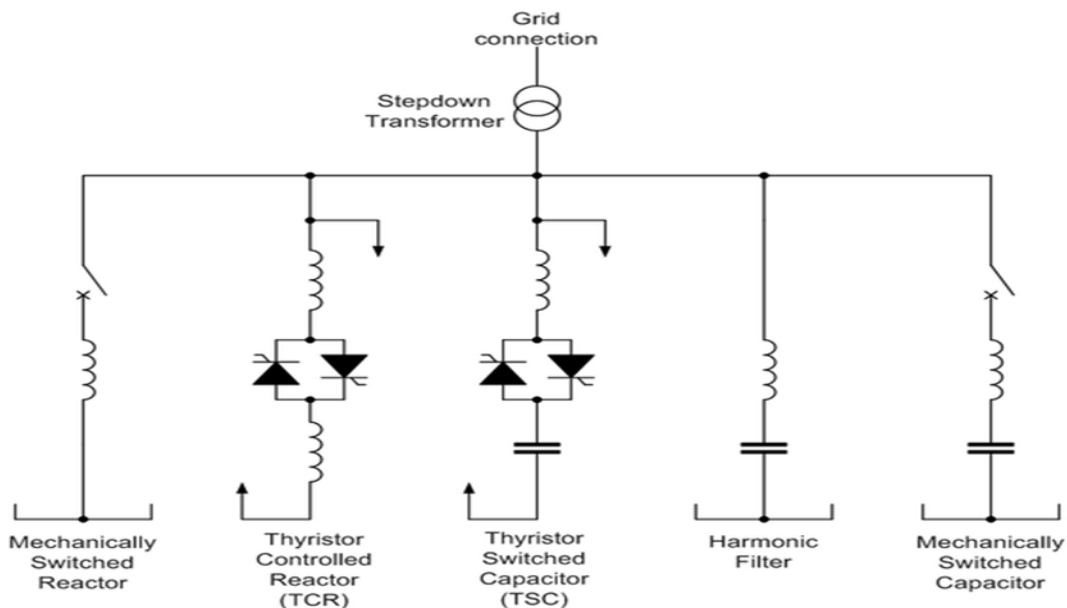

Figure 2.11: Single-line diagram of typical SVC configuration.

PQ Control of AALRT Power Supply System using SVC & Harmonic Filter

In steady-state, the SVC will provide some steady-state control of the voltage to maintain it the high-voltage bus at pre-defined level. If the high voltage bus begins to fall below its set point range, the SVC will inject reactive power into thereby increasing the bus voltage back to its desired voltage level. If the bus voltage increases, the SVC will inject less (or TCR will absorb more) reactive power, and the result will be to achieve the desired bus voltage.

Types of SVC controller

- ❖ Thyristor Controlled Reactor (TCR): in this type of SVC, a reactor with thyristor valve is incorporated in each phase. Reactive power is varied by controlling the current through the reactor using the thyristor valves. This type of SVC is characterized by smooth and continuous control.
- ❖ Thyristor Switched Capacitor (TSC): in this type of SVC, a shunt capacitor bank is divided into an appropriate number of branches. Each branch is individually switched on or off through anti-parallel connected thyristors. The main characteristics of this type of SVC are step and smooth control, no harmonics, low losses and flexibility.
- ❖ Fixed Capacitor thyristor Reactor (FC-TCR): in this type of SVC, a TCR is used in combination with a fixed capacitor bank when reactive power generation is required. This is often the optimum solution for sub-transmission and distribution applications. The main characteristics of this type of SVC are smooth and continuous control, elimination of harmonics by tuning the fixed capacitors and compact design.
- ❖ Thyristor Controlled Reactor- Thyristor Switched Capacitor (TCR-TSC): in this type of SVC, the TCR and the TSC is combined to get an optimum solution in many cases. With a TCR-RSC SVC, continuously variable reactive power can be obtained across the entire control range, with full control of both the inductive and the capacitive parts of the compensator. The principle benefit is optimum performance during major disturbances in the system such as line faults and load rejections. This type of SVC is characterized by continuous control, elimination of harmonics through TSC control, low losses, redundancy and flexibility.

Single-Phase TCR

A basic single phase TCR comprises an anti-parallel connected pair of thyristor valves, T_1 and T_2 , in series with a linear air-core reactor, shown in Figure 2.12. The anti-parallel thyristor pair acts like a bidirectional switch, with thyristor valve T_1 conducting in positive half-cycles and thyristor T_2 conducting in negative half-cycles of the supply voltage. The firing angle of the thyristors is measured from the zero crossing of the voltage appearing across its terminal.

The controllable range of the TCR firing angle, α , extends from 90° to 180° . The continuous sinusoidal current flow in the TCR but as α range, the current reduces to zero for a firing angle of 180° and below 90° , it introduce a dc current, disturbing the symmetrical operation of the two anti-parallel valve branches.

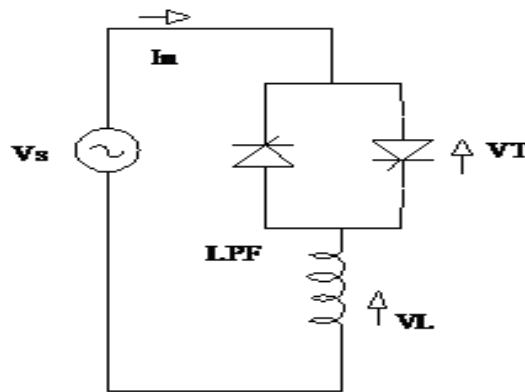

Figure 2.12: Circuit diagram of TCR

The basic modeling of single phase TCR can be as follows. The source voltage as

$$V_s(t) = V \sin \omega t$$

From the basic Kirchhoff's voltage equation

$$L \frac{di}{dt} - V_s(t) = 0 \quad (2.30)$$

Where V is peak value of the applied voltage, ω is the angular frequency of the supply voltage and L is inductance of the TCR, then the line current can be written as

PQ Control of AALRT Power Supply System using SVC & Harmonic Filter

$$i(t) = \frac{1}{L} \int V_s(t) dt + C \quad (2.31)$$

$$i(t) = -\frac{V}{\omega L} \cos \omega t + C \quad (2.32)$$

For the boundary condition is $i(\omega t = \alpha) = 0$

$$i(t) = -\frac{V}{\omega L} (\cos \alpha - \cos \omega t) \quad (2.33)$$

Where α is the firing angle measured from positive going zero crossing of the applied voltage.

The Fourier analysis of equation (3.4) can be written as

$$I(\alpha) = a_1 \cos \omega t + b_1 \sin \omega t \quad (2.34)$$

Where $b_1 = 0$, because of odd symmetry i.e, $f(x) = f(-x)$. Also not even harmonics are generated because of half wave symmetry i.e, $f(x + \frac{T}{2}) = -f(x)$

The coefficient a_1 is given by

$$a_1 = \frac{4}{T} \int_0^{\frac{T}{2}} f(x) \cos\left(\frac{2\pi x}{T}\right) dx \quad (2.35)$$

Solving,

$$I_1(\alpha) = \frac{V}{\omega L} \left(1 - \frac{2\alpha}{\pi} - \frac{1}{\pi} \sin 2\alpha\right) \quad (2.36)$$

Equation 3.7 can be written as

$$I_1(\alpha) = V B_{TCR}(\alpha) \quad , \text{ where}$$

$$B_{TCR}(\alpha) = B_{max} \left(1 - \frac{2\alpha}{\pi} - \frac{1}{\pi} \sin 2\alpha\right) \quad (2.37)$$

$$\text{Where } B_{max} = \frac{1}{\omega L}$$

The TCR is act like a variable susceptance. Variation of firing angle changes the susceptance and consequently the fundamental-current component which leads to a variation of reactive power absorbed by the reactor because the applied ac voltage is constant.

TSC

It consists of capacitor in series with bidirectional thyristor switch. It is supplied from an ac voltage source. The analysis of the current transients after closing the switch brings two cases.

- ❖ The capacitor voltage is not equal to the supply voltage when the thyristors are fired. Immediately after closing the switch, a current of infinite magnitude flows and charges the capacitor to the supply voltage in an infinite short time. The switch realized by the thyristor cannot with stand this stress and would fail.
- ❖ The capacitor voltage is equal to the supply voltage when the thyristors are fired. The current will jump immediately to the value of the steady-state current. Although the magnitude of the current does not exceed the steady-state value, the thyristor have an upper limit of $\frac{di}{dt}$ that they can with stand during the firing process.

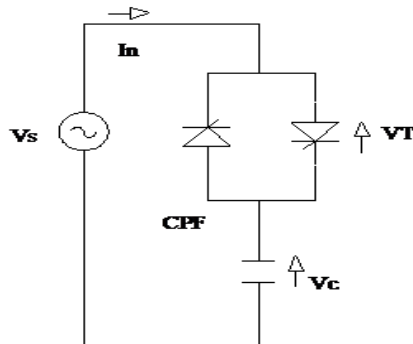

Figure 2.13: Circuit diagram of TSC

The TCR-TSC comprises usually n-series of TSC and single TCR that are connected in parallel. The capacitor can be switched in discrete steps, whereas continuous control within the reactive power span of each step is provided by TCR.

Benefits of using SVC

- ❖ Voltage fluctuations in the feeding grids caused by heavy fluctuations of the railway loads can be dynamically mitigated.
- ❖ Harmonics injected into supply grids from traction devices can be eliminated.
- ❖ From power quality (PQ) point of view, the feeding grid can be chosen with a lower voltage with FACTS.
- ❖ FACTS devices provide dynamic voltage control and harmonic mitigation of AC supply systems for DC converter fed traction.
- ❖ Extension of existing lines where the SVC device can support voltages at the end of branch without the need for a new costly feeder station.
- ❖ Reduction in the power losses of distribution system.

2.10.2. Harmonic Filter

Using power electronic converter in electric transportation systems such as electric trains causes a lot of harmonic levels inject to distribution networks. Harmonic filters are used to limit the harmonic currents flowing into the upstream network.

Non-linear loads produce harmonic current that can travel to other locations in the power system and eventually back to the source. One means of ensuring that harmonic currents produced by a non linear current source will not excessively interfere with the rest of the power system is to filter out the harmonics. Application of harmonic filter helps to accomplish this.

Passive, Active and their mixture (hybrid) are three kinds of filters. Passive filters as classic methods for power quality improvement of the distribution systems consists of series LC tuned for removing a specific harmonic or blocking a bandwidth of severals harmonics of non-linear loads current.

CHAPTER THREE

MODELING OF COMPONENTS

3.1. Introduction

Addis Ababa LRT phase I project has two routes, North-South and East-West. Each route receives power from four different EEPCO (Ethiopian Electric Power Corporation Authority) Utility substations that located at the four edges of rail routes. The four EEPCO side railway traction substations; Menelik II, Kality, Ayat and Torhailoch are installed with double circuits of transformer capacity 25 MVA, 132KV/15KV.

In the power distribution system of AA LRT system the 15 KV AC voltages is received from the EEPCO (Ethiopian Electric Power Corporation Authority) power system and transformed down to the appropriate AC voltage 0.59KV in the substation transformer for LRT system, and it is converted to DC voltage 750V by rectification equipment. Each of EEPCO substations provides power supply for the half of the LRT rectifier substations found on the route.

The analysis of power quality problem on an electrified railway system is essential to assess the effects of the railway system on the adjacent distribution network and to enable the analysis of train performance.

Electrified railway systems are electrically complex. The load, trains, are constantly moving and their electrical behavior is constantly changing. Modeling is an ideal tool to analyze the power quality of such complex system.

Depending on the purpose of the analysis different models of the same physical system or components might be valid. In this section the traction power system components are modeled in order to perform the power quality analysis throughout the system. The traction power components have independently modeled and finally cascaded to represent the entire system.

3.2. Distribution line Modeling

In the distribution lines, there are two categories of traction power system, AC and DC. The AC distribution line transmits electrical power from the national grid to the traction substation, whereas the DC distribution line delivers electrical power to load side. In both cases, the transmission of power depends on the physical properties of the distribution line to reach the receiving end in the preferred condition. The distribution line performance is determined by its voltage drop, line losses and efficiency. The AC distribution lines are modeled using its series resistance, series inductance, shunt capacitance, and shunt conductance. There are three ways in common practice to model power transmission line. The three models are the short line model, medium line model and long line models.

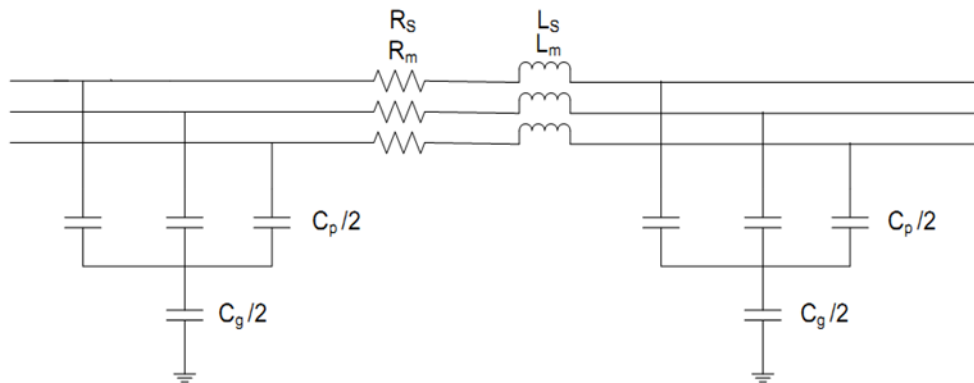

Figure 3. 1 Equivalent circuit of three phase Pi-circuit model [19]

The line parameters R , L , and C are specified as positive- and zero-sequence parameters that take into account the inductive and capacitive couplings between the three phase conductors, as well as the ground parameters. This method of specifying line parameters assumes that three phases are balanced.

The self and mutual resistances (R_s , R_m), self and mutual inductance (L_s , L_m) of the three coupled inductors, as well as phase capacitance C_p and ground capacitances C_g , are deduced from the positive- and zero-sequence RLC parameters as follows:

We assume the following line parameters:

PQ Control of AALRT Power Supply System using SVC & Harmonic Filter

r_1, r_0 positive-and zero-sequence resistance per unit length (Ω/km)

l_1, l_0 positive-and zero-sequence inductance per unit length (H/km)

c_1, c_0 positive-and zero-sequence capacitance per unit length (F/km)

f frequency (Hz)

l_{sec} Line section length (Km)

The RLC line section parameters are then computed as follows:

$$R_s = \frac{2R_1 + R_0}{3} \qquad R_m = \frac{R_0 - R_1}{3} \qquad (3.1)$$

$$L_s = \frac{2L_1 + L_0}{3} \qquad L_m = \frac{L_0 - L_1}{3}$$

$$C_p = C_1$$

Catenary Line Model

Electrical trains take power form conductor named contact wire using a device named pantograph. The catenary system have different types of geometry due to system design, environmental conditions, voltage level, substation distance, voltage drop, impedance etc ...

An overhead contact system behaves as a transmission line and has certain values of resistance, capacitance and inductance per unit length that are determined by physical characteristics such as the diameters of the contact wire and the height above the ground. As a result the overhead contact system has characteristic impedance which by transmission line theory can be shown to alternate between capacitive and inductive values in the form of hyperbolic curve. The supply from the grid to the feeder station is essentially inductive and resonant conditions exist between the supply and the overhead contact system, i.e. the system has a set of characteristic resonant frequencies.

Considering the movement of train between two stations, amount of electrical parameters of DC line are changing perpetually. As a result, for accurate analysis of power quality index in traction

PQ Control of AALRT Power Supply System using SVC & Harmonic Filter

system, it is needed to model these changes. According to Figure 3.2, trains in each time, is located in special position with special speed.

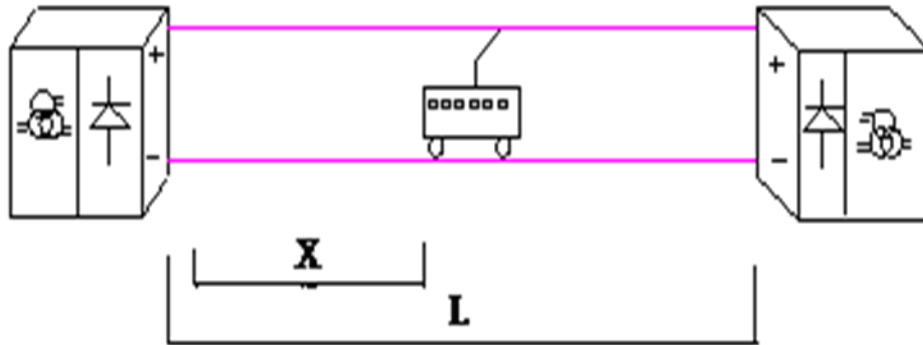

Figure 3. 2 Spatial status of between two train stations

To model position and speed of railway in power quality calculation, first of all, parameters per length of DC line should be determined. The characteristic behavior of DC line is purely resistive. The DC traction line is modeled using resistive elements.

Now with these parameters and speed characteristic of train that shown in Figure 3.3, model of DC line can be obtained. As shown in Figure 3.3, it is assumed that railway start moving from first station and accelerates movement to maximum speed after t_1 seconds. Then, it continues with the same speed until t_2 that railway reduces its speed to stop at second station at t_{max} .

To model the position of train and the effect of DC line in simulation, every moment, the train speed and distance traveled by the train is computed. After that, the electrical parameters of the DC line are determined, considering the amount of length that is travelled by the train. Since the distance between stations is about 1.724 km in average, the appropriate model for the DC line is Pi model.

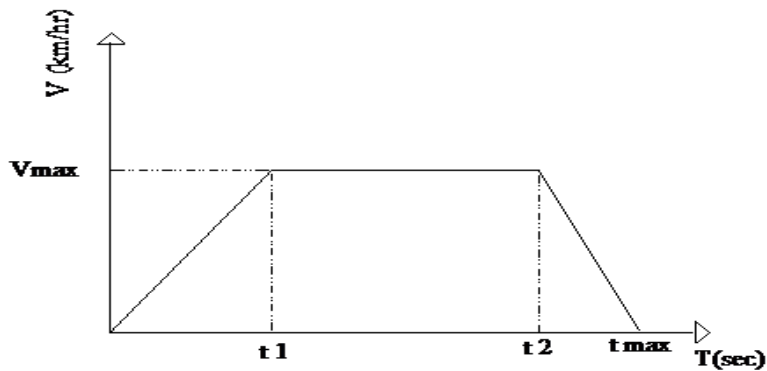

Figure 3.3: Speed characteristic of the train sets with time variation

3.3. Rectifier Substation Modeling

The main components of traction rectifier substation are the traction rectifier transformers and rectifier units.

Traction Rectifier Transformer Model

Traction rectifier transformers are power transformers used to convert high voltage AC supply to AC voltages with smaller magnitude and varying phases, suitable as inputs to the rectifiers. The rectifier transformers are special transformers with delta primary winding and both delta and star connected secondary. The two secondary windings are connected in such a way that a phase shift of 30° for current and voltage waveform appears at the output side.

For the balanced three phases system per phase equivalent circuit of the rectifier transformer is given as shown in figure 3.4.

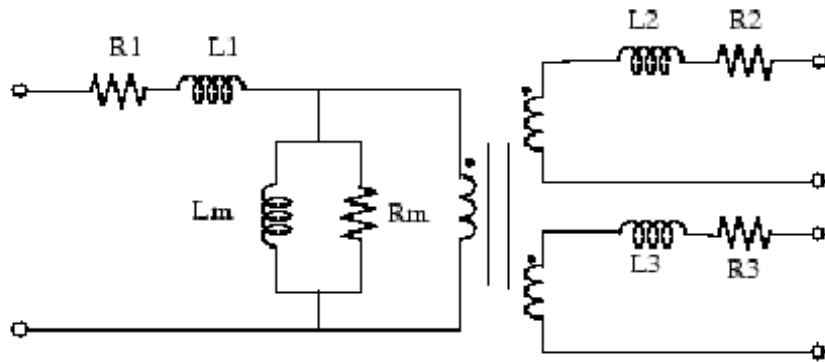

Figure 3.4: Equivalent circuit of three winding transformer

Rectifier unit Model

The LRT traction rectifier is 12-pulse rectifier that has a combination of two three-phase bridges rectifier connected in parallel, as shown in the Figure3.5.

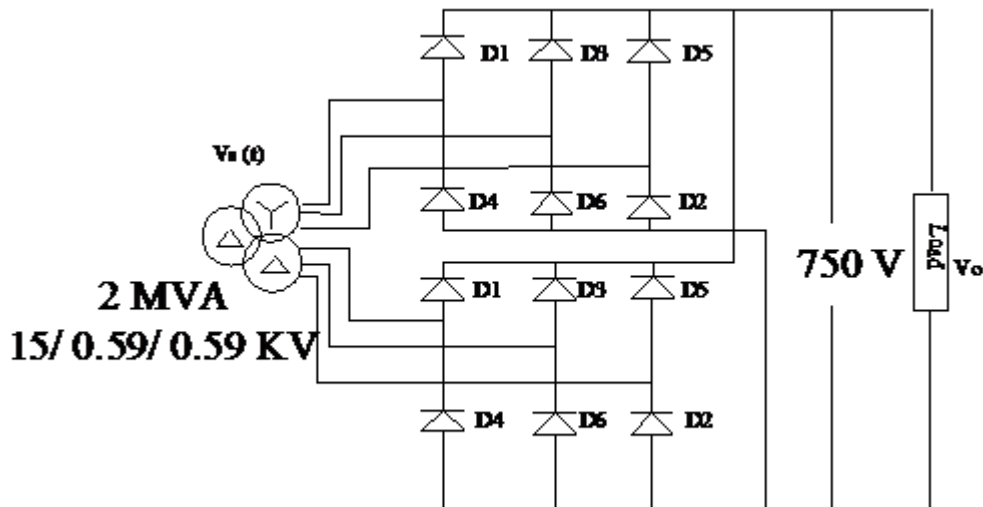

Figure 3.5: 12- pulse diode rectifier circuits

Many harmonic models have been proposed for representing three-phase power electronic device. The most common model is in the form of a harmonic current source, which is specified by its magnitude and phase spectrum [16].

PQ Control of AALRT Power Supply System using SVC & Harmonic Filter

The amplitude of harmonic currents generated by a diode rectifier with smoothing reactor on the DC side is almost constant even if source impedance varies, because the impedance on the DC side is much larger than the source impedance on the AC side. Therefore, in conventional equivalent circuits, the rectifier has been widely considered as an ideal current source for harmonics. But, in rectifier circuits, there are both current harmonics on AC side and voltage harmonic on DC side.

In rectifier circuit AC source is processed through a set of switches to create a well defined waveform. In this equivalent circuit we can represent the combined action of an actual source (AC source) and a set of switches by equivalent source. Based on superposition, a term-by-term for the Fourier series of current and voltage in the rectifier circuits can be solved. The equivalent voltage source, $V_o(t)$, contain both the fundamental component and harmonic components of the voltage. The Fourier series of the voltage $V_o(t)$ can be expressed in trigonometric form as, (detail is given in section 2.7)

$$V_o(t) = V_{dc} + \sum_{n=6,12,18,..}^{\infty} a_n \cos(n\omega t) + \sum_{n=6,12,18,..}^{\infty} b_n \sin(n\omega t) \quad (3.2)$$

$$V_o(t) = \frac{3\sqrt{3}}{\pi} V_m + \frac{6\sqrt{3}}{35\pi} V_m \cos(12\omega t) + \frac{6\sqrt{3}}{143\pi} V_m \cos(24\omega t) + \frac{6\sqrt{3}}{323\pi} V_m \cos(36\omega t) + \dots$$

The source currents are depend on the load current. Therefore, these currents are modelled by a current controlled current source, which is controlled with load current. The equivalent circuit containing harmonic currents on the AC side and harmonic voltages on the DC side of the rectifiers, we represent an equivalent circuit on a per phase base.

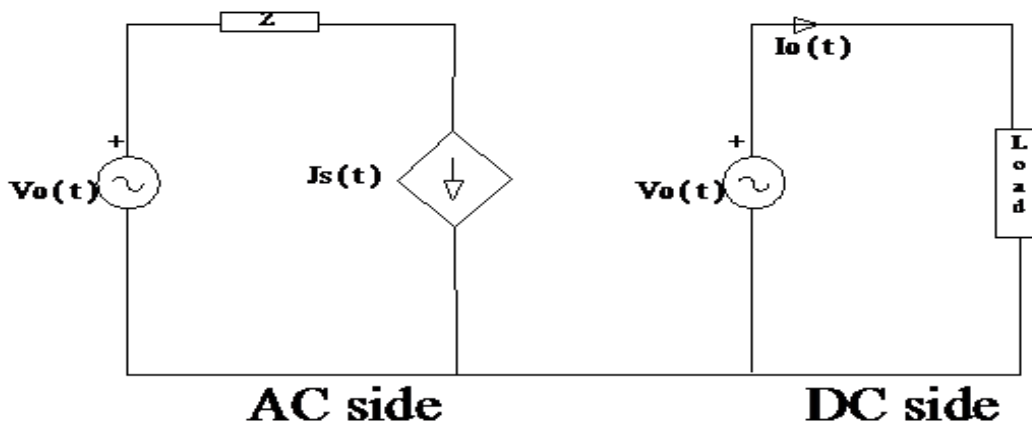

Figure 3.6: Simplified model of rectifier circuit

From the point of harmonic studies, the equivalent circuit can be divided into two circuits:

- ❖ An equivalent circuit to the fundamental component and
- ❖ An equivalent circuit to harmonics.

The equivalent circuit to harmonic components on both AC side and the DC side of the rectifier is obtained under the condition that the source voltage $V_s(t) = 0$, the first component of the harmonic current source $J_1(\omega_1 t) = 0$ and the first component of harmonic voltage source $V_1(\omega_1 t) = 0$. The equivalent circuit to harmonic is shown in figure 3.7

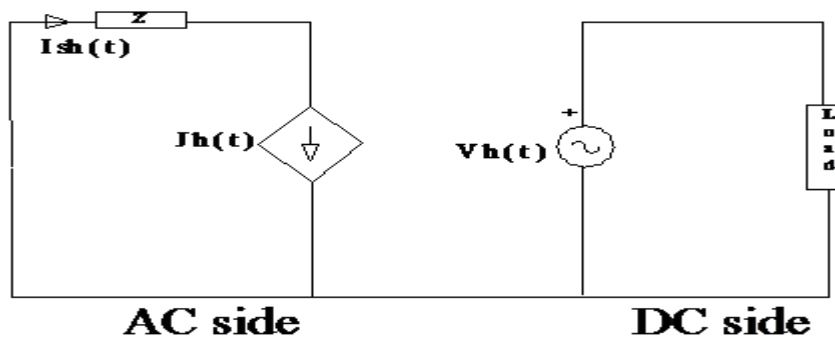

Figure 3.7: Equivalent circuit of harmonic components on the DC and AC side

3.4. Traction load (Train) Model

Squirrel-cage three phase asynchronous traction motor type is used to drive the tramcar. The DC current is collected from the overhead contact system (OCS) through the pantograph. This power is converted to AC with the use of inverter. The general traction load block diagram is given in Figure 3.8

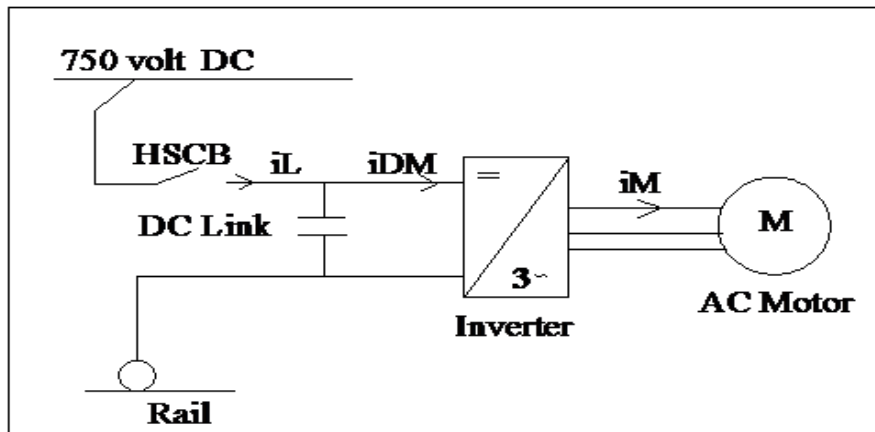

Figure 3.8: Traction load block diagram

The Variable Voltage Variable Frequency (VVVF) inverter with PWM technology is applied to control the train speed. The drive system uses a 6-pulse inverter with a high switching frequency device, Insulated Gate Bipolar Transistor (IGBT). With the high switching speeds and advanced PWM schemes, the performance of an inverter is significantly improved.

The VVVF inverter is mainly composed of circuit contactor unit, IGBT inverter and chopper power unit, logic control unit and filter capacitance device. The function of the VVVF inverter is to convert DC voltage to three-phase current of variable voltage and variable frequency.

Power drawn from the load (train) depends upon the train's speed and operation mode which are in turn determined by the traction equipment characteristics, train weight, aerodynamics, track geometry and train control strategies etc ... The power demand may thus vary significantly with in a very short period of time during an inter-station run. The number of train in a feeding section is also vital to the calculation as they may be running at different speeds, drawing (feeding) different amount of power and thus posing different effects on the supply system. Nominal

PQ Control of AALRT Power Supply System using SVC & Harmonic Filter

separation among trains is yet another important consideration and it should follow the timetables or dispatching schedules of the train services. As a summary of explanation determining load that takes power from catenary has a lot of difficulties and several different conditions have to be taken care, these conditions can be listed as in below:

- ❖ Load differences on different sections of catenary system
- ❖ Changing speed of vehicles in time interval due to driver behavior and time scheduling
- ❖ Size of load can change due to different vehicles and different traction motors
- ❖ Number of load can change due to traffic.

In practice, only the four electrical quantities (Pantograph voltage-magnitude, input current magnitude, power and power factor) can be either measured on-board a train or obtained from analytically calculation or the design requirements and any model that uses a well-chosen sub-set of these quantities is satisfactory [18].

Constant power model is widely used in three phase power flow problems. Power and power factors are the two quantities that can be measured by the on-board traction controller. Furthermore, applying tractive effort versus speed train running information with the Newton's Second law of motion, the model parameters, power and power factors can alternatively be calculated. In this thesis constant power model is used to model the power distribution system of traction power supply system components.

Calculating the equivalent traction loads:

$$\text{Traction motor voltage } V_{motor} = 500 \text{ V}$$

$$\text{Traction motor power } P_{motor} = 130 \text{ Kw}$$

$$\text{Power factor } \text{Pf} = 0.95$$

$$\text{Traction motor current } I_{motor} = \frac{P_{motor}}{V_{motor} \cdot \cos\phi} = \frac{130 \times 10^3}{500 \times 0.95} = \mathbf{273.68A}$$

$$\text{Reactive power } Q_{motor} = P_{motor} \times \tan(\cos^{-1}(0.95))$$

$$Q_{motor} = 130 \times 10^3 \times \tan(\cos^{-1}(0.95)) = \mathbf{42.73KVAR}$$

$$\approx 43 \text{ KAR}$$

The total power of the tram car is the sum of the traction motor rated power and train auxiliary powers (34KW).

$$\begin{aligned}\text{Total Power} &= 2 \times \text{Motor rated Power} + \text{Auxiliary Power} \\ &= 2 \times 130\text{KW} + 34\text{KW} \\ &= 294\text{KW}\end{aligned}$$

The apparent power with a power factor 0.95,

$$S = \frac{P}{P_f} = \frac{130 \times 10^3}{0.95} = 136.84 \text{ KVA}$$

The reactive power

$$\begin{aligned}Q &= \sqrt{S^2 - P^2} = \sqrt{136.84^2 - 130^2} = 42.72 \text{ KVAR} \\ &\approx 43 \text{ KAR}\end{aligned}$$

3.5. The SVC Model

Thyristor-controlled reactor (TCR)

A TCR is one of the most important building blocks of thyristor-based Thyristors. Although it can be used alone, it is more often employed in conjunction with fixed or thyristor-switched capacitor (TSC) to provide rapid, continuous control of reactive power over the entire selected lagging-to-leading range. TSC is used for the reducing or totally compensating the inductance reactive power produced by the load. Since TSC has on/off working principle, in other words single capacitance admittance is connected to or disconnected from the system, the total reactive power that the system needs should be carefully determined so that there is not much excess capacitive reactive power produced by TSC.

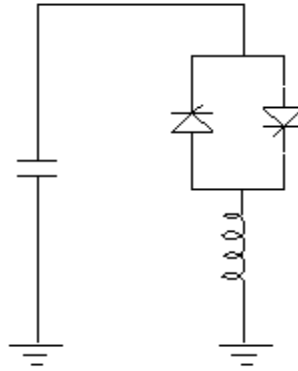

Figure 3.9: SVC System

The fixed capacitors, and the thyristor controlled reactor may be considered essentially to consist of a variable reactor and a fixed capacitors, with an overall var demand versus var out characteristic. The fixed capacitor bank alone supplies a part of the capacitive var required by the system, while the other part of the filter provides the remaining reactive power. The filter is placed in parallel with the fixed capacitors bank and they are tuned to the most relevant harmonic frequency.

The reactance of the TCR and FC are calculated as follows:

$$X_{rated} = \frac{V_{rated}^2}{Q_{rated}} = \frac{15^2}{43} = 5.23\Omega \quad [27]$$

$$X_{transf} = \frac{Z\% \times V_{rated}^2}{Q_{rated}} = \frac{0.08 \times 15^2}{43} = 0.419\Omega$$

$$X_{TCR} = X_{rated} - X_{transf}$$

$$X_{TCR} = 5.23\Omega - 0.419\Omega = 4.811\Omega$$

$$L = \frac{X_{TCR}}{2\pi f} = \frac{4.811}{2\pi \times 50} = 15.31mH$$

$$C = \frac{1}{2\pi f X_{rated}} = \frac{1}{2\pi \times 50 \times 5.23} = 608.62\mu F$$

3.6. Harmonic Filter Design

The traction power converters inject harmonics to the AC and DC side of the system. The AC side harmonic enters the grid network where it can easily flow to other loads connected to the network. The DC side harmonic appears on the load side where it affects the proper operation of the motors.

Single tuned filters (STF) are probably most common type of filter which is used in industry broadly for harmonic mitigation. The basic principle of using passive filter is that on tuned frequency filter will offer low impedance to current through which harmonic current will tends to divert the system.

A very simple arrangement of Single tuned filter is shown in the figure 3.10

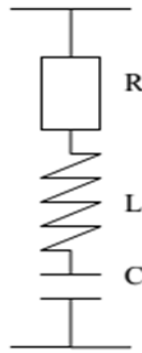

Figure 3.10: Simple connection diagram of single tuned filter

Two single tuned filters for 11th and 13th are designed for the section. The designing of these filters are in such a way that they will precisely employ for each specified harmonic frequency for which is has been tuned. In designing a single tuned filter, generally the filter capacitor is sized for a known reactive power compensation required to improve the line power factor.

The harmonic filter can also provide a large percentage of reactive power for the power factor correction. When the capacitor, Q_{com} KVA is installed in a system with a real power load P KW, the power factor can be improved from P_{f0} to P_{f1} .

$$Q_{com} = p \times [\tan(\cos^{-1}(P_{f0})) - \tan(\cos^{-1}(P_{f1}))] \quad (3.3)$$

PQ Control of AALRT Power Supply System using SVC & Harmonic Filter

The capacity of a single tuned filter can be set to

$$Q_{com} = Q_f \quad (3.4)$$

The other important term, which is tentatively to keep in mind during the designing of a filter, is quality factor. It determines the “sharpness” of the “tuning” of the passive filter and is given by the ratio of reactance at the resonant condition and resistance of the circuit as follows in equation 3.5.

$$Q_f = \frac{X_C \text{ or } X_L}{R} \quad (3.5)$$

Where, Q_f = quality factor

R= resistance of filter in ohms

In single tuned filter, the inductive and capacitive reactance at the tuned frequency should be equal. If X_0 is the reactance the capacitance or filter reactor at its tuned frequency

$$X_0 = \omega_n L = \frac{1}{\omega_n C} = \sqrt{\frac{L}{C}}$$

For single tuned filter, typical value of quality factor fluctuates in between 50 to 150.

The capacity of the traction rectifier transformer is 2000KVA. When the transformer is fully supplying power, the reactive power will be,

$$\begin{aligned} Q_{trans} &= S \times \sin\left(\cos^{-1}(P_f)\right) \\ &= 2000 \times \sin\left(\cos^{-1}(0.95)\right) = \mathbf{624.5 \text{ K VAR}} \end{aligned}$$

Using the current Fourier transform, the expression for individual harmonics can be expressed as follows using equation 2.22.

$$I_A = \frac{4\sqrt{3}}{\pi} I_o \left(\cos \omega t - \frac{1}{11} \cos 11\omega t + \frac{1}{13} \cos 13\omega t - \frac{1}{23} \cos 23\omega t + \dots \right)$$

PQ Control of AALRT Power Supply System using SVC & Harmonic Filter

$$= 2.21 I_o \cos \omega t - 0.2 \cos 11\omega t + 0.17 \cos 13\omega t - 0.096 \cos 23\omega t + \dots$$

The sum of all harmonic currents up to 50th order is equal to $I_{total} = 0.549 I_o$ rms

For single tuned 11th harmonic,

$$\begin{aligned} Q_{11f} &= Q_{com} \times \frac{I_{11}}{\sum I_h}, h=2, 3 \dots \\ &= 624.5 \times \frac{0.142 I_o}{0.549 I_o} = 161.53 \text{ KVAR} \end{aligned}$$

The capacity of the capacitor and inductor of 11th harmonic filter is calculated as,

$$Q_{11C} = Q_{11f} \times \frac{h^2}{h^2-1} = 161.53 \times \frac{11^2}{11^2-1} = \mathbf{162.88 \text{ KVAR}}$$

$$Q_{11L} = Q_{11C} - Q_{11f} = 162.88 - 161.53 = \mathbf{1.88 \text{ KVAR}}$$

Then, the capacitive and inductive reactances are:

$$X_{11C} = \frac{KV^2}{Q_{11C}} = \frac{15000^2}{162.88} = 1381.38 \Omega$$

$$X_{11L} = \frac{X_{11C}}{n^2} = \frac{1381.38}{11^2} = 11.42 \Omega$$

$$\text{Now, } C_{11} = \frac{1}{2\pi f X_{11C}} = 2.30 \mu F$$

$$L_{11} = \frac{X_{11L}}{2\pi f} = 36.35 \text{ mH}$$

Similarly, we calculate for the 13th harmonic

$$\begin{aligned} Q_{13f} &= Q_{com} \times \frac{I_{13}}{\sum I_h}, h=2, 3 \dots \\ &= 624.5 \times \frac{0.12 I_o}{0.549 I_o} = 136.5 \text{ KVAR} \end{aligned}$$

The capacity of the capacitor and inductor of 13th harmonic filter is calculated as,

PQ Control of AALRT Power Supply System using SVC & Harmonic Filter

$$Q_{13C} = Q_{13f} \times \frac{h^2}{h^2-1} = 136.5 \times \frac{13^2}{13^2-1} = \mathbf{137.31 \text{ KVAR}}$$

$$Q_{13L} = Q_{13C} - Q_{13f} = 137.31 - 136.5 = \mathbf{0.81 \text{ KVAR}}$$

Then, the capacitive and inductive reactances are:

$$X_{13C} = \frac{KV^2}{Q_{13C}} = \frac{15000^2}{137.31} = 1638.63 \Omega$$

$$X_{13L} = \frac{X_{13C}}{n^2} = \frac{1638.63}{13^2} = 102.41 \Omega$$

$$\text{Now, } C_{13} = \frac{1}{2\pi f X_{13C}} = 1.94\mu F$$

$$L_{13} = \frac{X_{13L}}{2\pi f} = 325.98mH$$

The single tuned filter [see figure 3.10] contains a capacitor in series with an inductor. The capacitor and inductor are sized such that the branch impedance is zero near a harmonic frequency, which bypasses that harmonic. The capacitor also provides reactive power compensation. A resistor can be used in order to adjust the tuning's sharpness and, as a consequence, the bandwidth. In this case the quality factor is given by in equation 3.5.

$$Q_f = \frac{\sqrt{L/C}}{R} \quad \text{Where, } 50 < q_f < 150 \quad (3.6)$$

When n harmonic order, and by using equation (3.6) above the value of resistance can be calculate

$$R = \frac{\sqrt{L/C}}{Q_f}$$

Let, $Q_f=80$

$$R_{11} = \frac{\sqrt{L_{11}/C_{11}}}{q_f} = \frac{\sqrt{36.35mH/2.3\mu F}}{80} = 1.57 \Omega$$

$$R_{13} = \frac{\sqrt{L_{13}/C_{11}}}{q_f} = \frac{\sqrt{325.98mH/1.94\mu F}}{80} = 5.12 \Omega$$

CHAPTER FOUR

SIMULATION RESULTS AND DISCUSSION

In this chapter, Simulation setups, results, discussions and related issues discussed. The simulation of the traction power supply system is done using Matlab/ Simulink environment. Power system component is represented by a block in which it is possible to vary the component characteristic parameters.

A simulation model of the traction power supply network with and without SVC and Harmonic filter was prepared simulated in MATLAB/SIMULINK with Simpower systems of Matlab program version (R2013a) so as investigate circuit waveforms, steady-state performance, voltage and current ratings and real and reactive power ratings.

SIMULATION MODEL PARAMETERS

Table 4.1: Simulation parameters

Voltage source	Line-to-line voltage	132 KV
	Frequency f	50 Hz
	Three phase short circuit level	25 MVA
	X/R ratio	24
AC transmission Line	Positive and zero sequence resistance (Ω/Km)	$r_1 = 0.697$ $r_0 = 7.738$
	Positive and zero sequence inductance (H/Km)	$l_1 = 1.566 \times 10^{-3}$ $l_0 = 24.6 \times 10^{-3}$
	Positive and zero sequence capacitance (F/Km)	$c_1 = 6.79 \times 10^{-9}$ $c_0 = 6.79 \times 10^{-12}$
Rectifier Transformer	Nominal Power	2 MVA
	Winding 1	15KV Vrms, R1=0.0233, L1 =0.008
	Winding 2	590 Vrms, R2=0.01165, L2=0.004
	Winding 3	590 Vrms, R2=0.01165,

PQ Control of AALRT Power Supply System using SVC & Harmonic Filter

		L2=0.004
DC OCS	Resistance (Ω/Km)	0.123
Traction Motor	Rated Power	145 KVA
	Frequency	91 Hz
	Rated Voltage	500 Vrms
	Power Factor	0.95

4.1. Simulation of Traction Power Supply System without SVC and Harmonic Filter

A Simulink model of the traction power supply system is developed for the maximum possible traction loads.

Simulation diagram of existing traction power supply system without SVC and Harmonic filter schematic simulation diagram and its output waveform is shown from figure 4.1 to figure 4.3.

Figure 4.1 shows simulation diagram of existing system without SVC and Harmonic filter. The simulation diagram includes AC distribution line, the rectifier substation model, the catenary line model and load (train model).

PQ Control of AALRT Power Supply System using SVC & Harmonic Filter

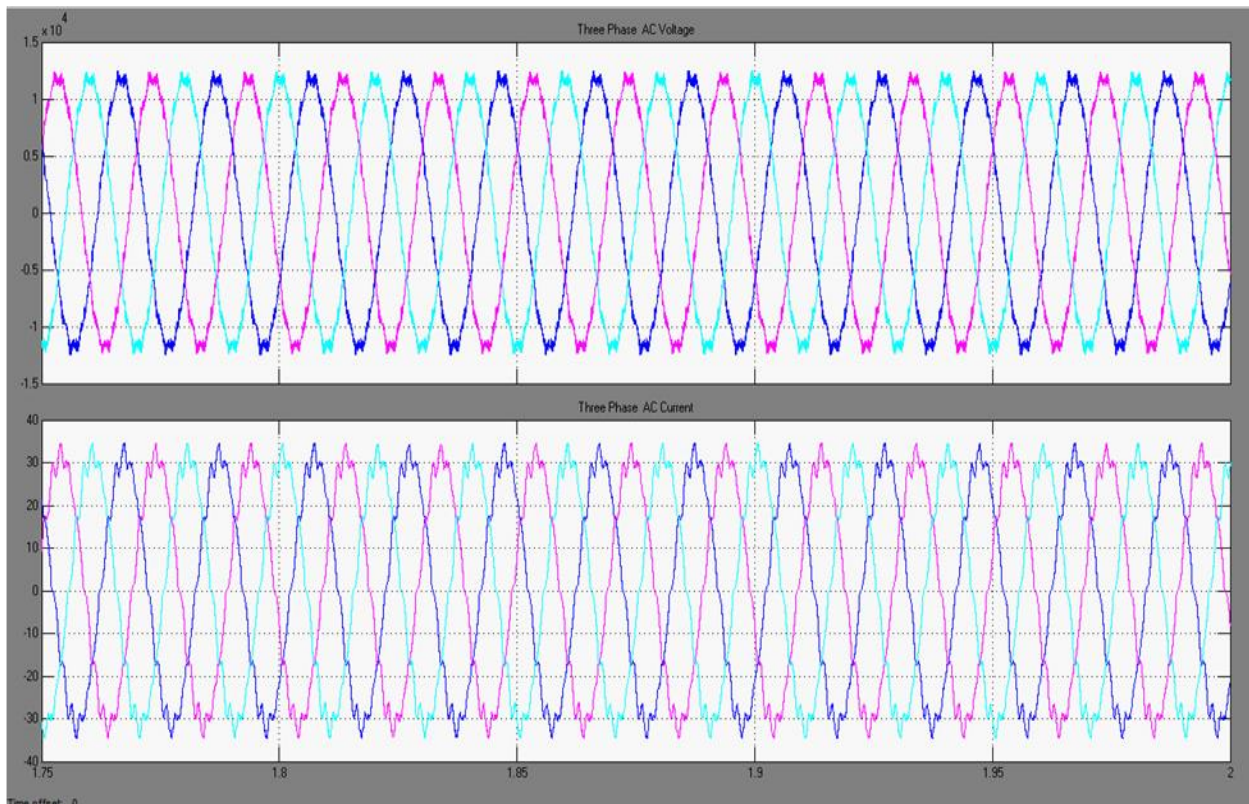

Figure 4. 2 AC voltage and current waveforms at PCC, without SVC & harmonic filter

Figure 4.2 shows that the voltage and current waveform at PCC are distorted. The AC voltage and current spectrum at the PCC without SVC and harmonic filter are shown in Figure 4.3. The THD value corresponding to voltage is 6.99% while the current has 16.38%

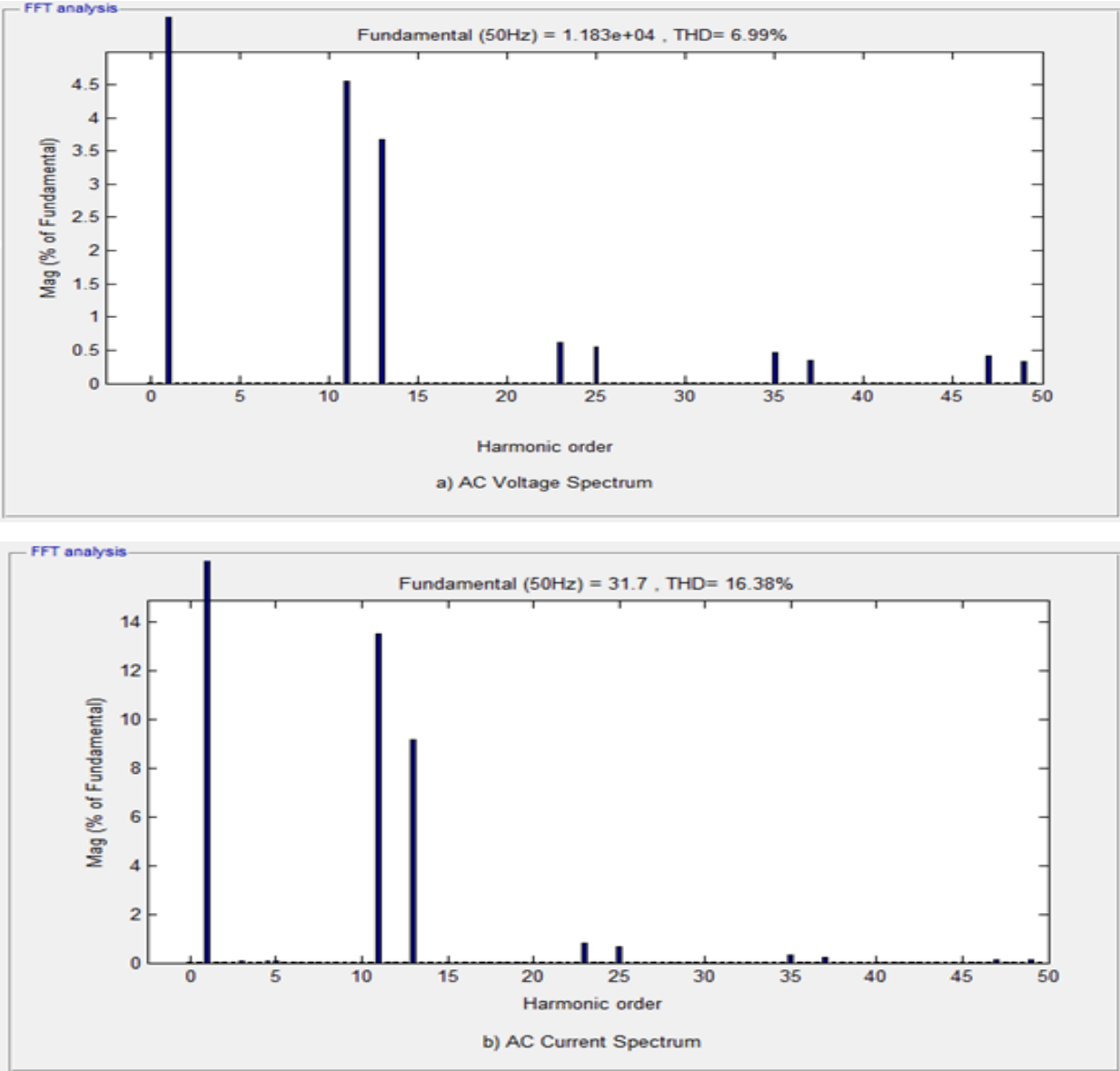

Figure 4.3: AC voltage and current harmonic spectrum at PCC, without SVC and harmonic filter

4.2. Simulation of Traction Power Supply System with SVC and Harmonic Filter

The simulation diagram of proposed SVC and Harmonic filter and its output wave form is shown in figure 4.4. In this simulation, traction substation is composed of 2MVA traction rectifier transformer that is connected as D/Y/D (15/0.59/0.59 KV). Moreover, output of traction rectifier transformer linked up with rectifier. 12 pulse rectifiers connected to get DC voltage for the tram car. This system is analyzed under different load conditions.

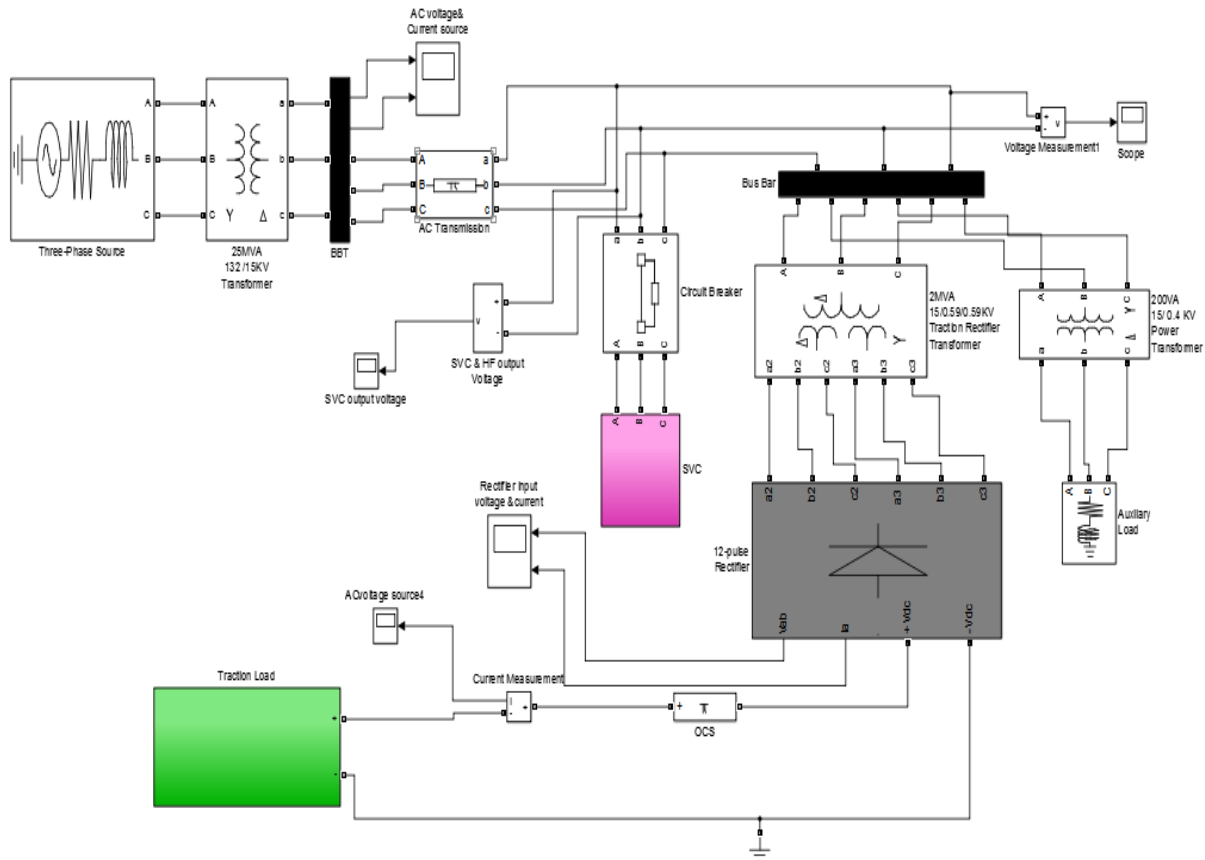

Figure 4.4: Block diagram of electrical network model with SVC and Harmonic filter

PQ Control of AALRT Power Supply System using SVC & Harmonic Filter

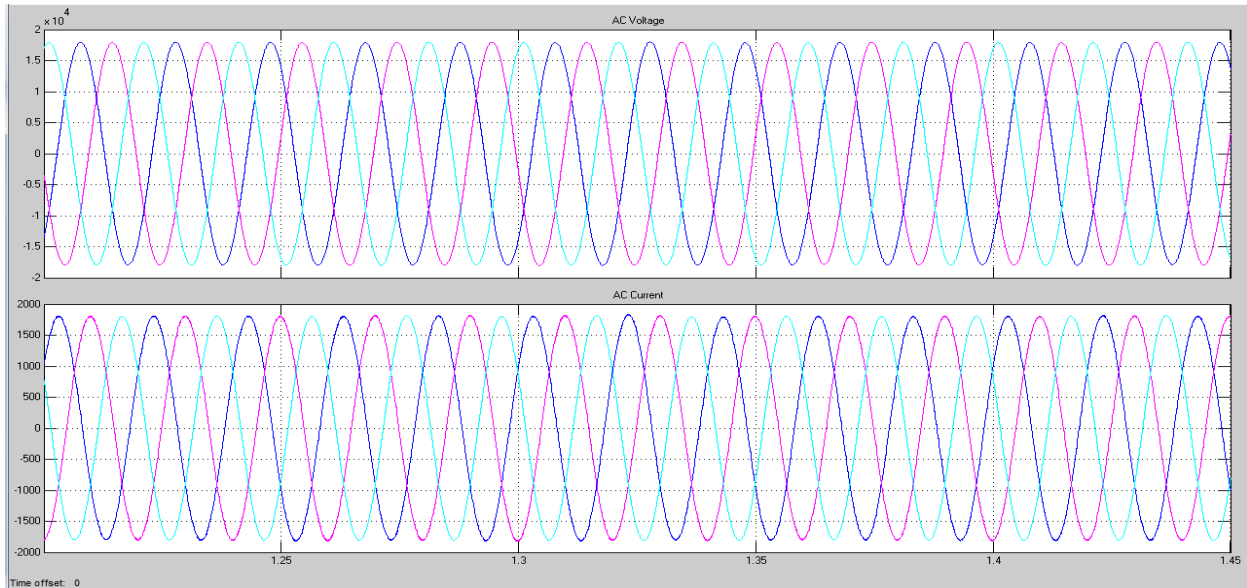

Figure 4.5: AC voltage and current wave form at PCC, with SVC & harmonic filter

The AC voltage and current spectrum at the PCC with SVC and harmonic filter are shown in figure 4.6. The THD value corresponding to voltage is 0.26% and the current has 0.36%

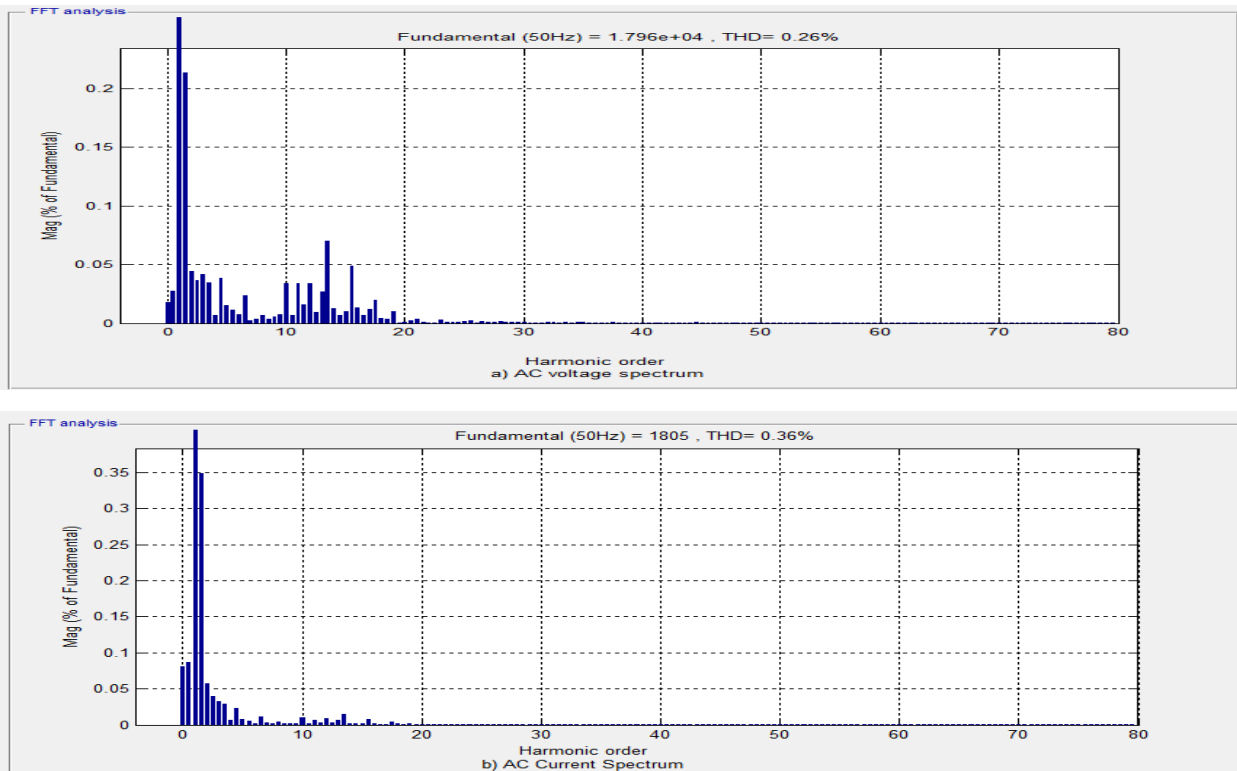

Figure 4.6: AC voltage and current harmonic spectrum at PCC, with SVC and harmonic filter

PQ Control of AALRT Power Supply System using SVC & Harmonic Filter

The output wave shape for the load current without SVC and harmonic filter and with SVC and harmonic filter is shown in Figure 4.7 and Figure 4.8 respectively.

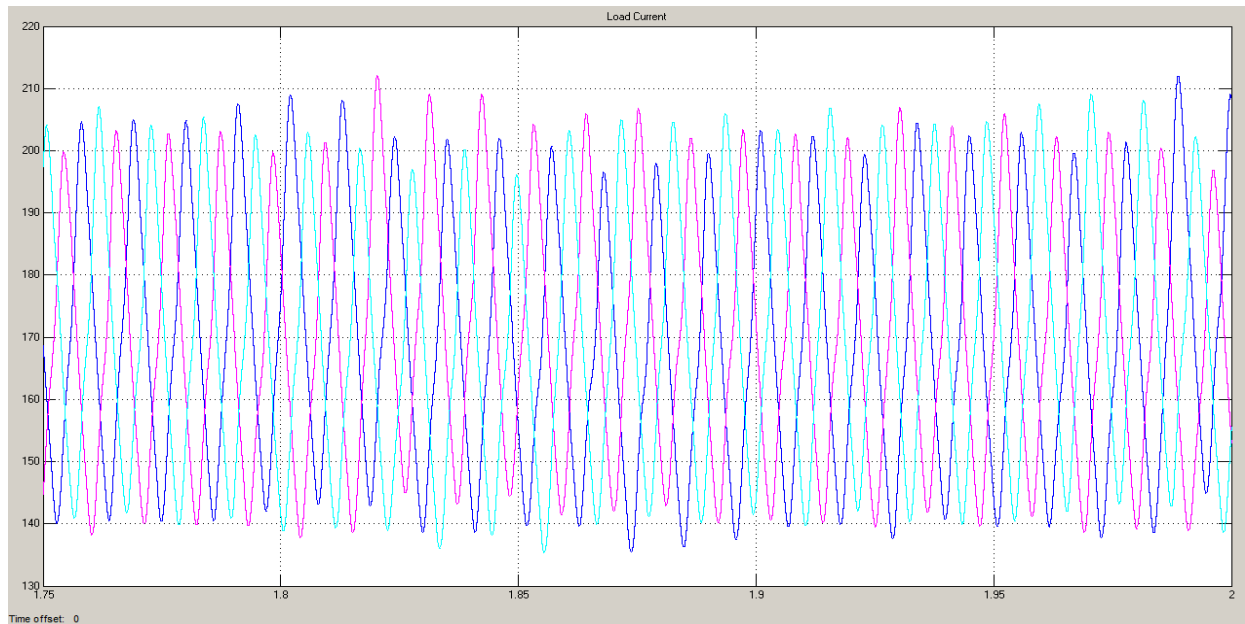

Figure 4.7: Load current without SVC and harmonic filter

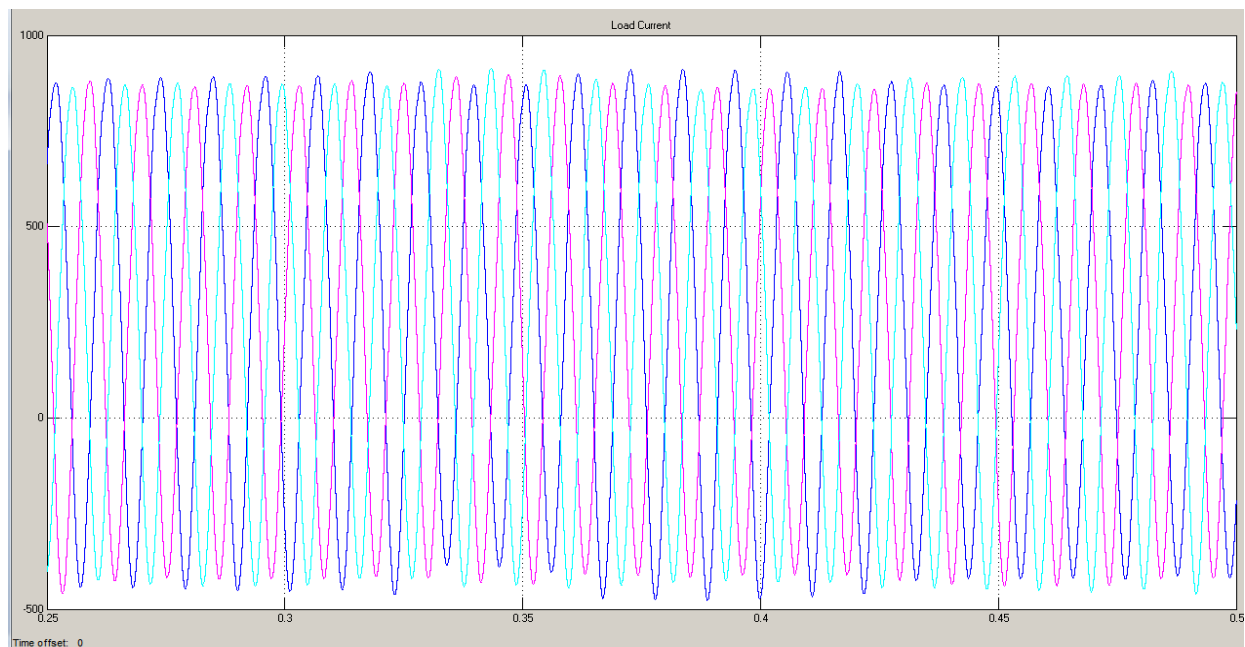

Figure 4.8: Load current with SVC and harmonic filter

PQ Control of AALRT Power Supply System using SVC & Harmonic Filter

The main power quality parameters at the PCC (Voltage THD and current THD) are shown in Table 4.2

Table 4.2: Total Harmonic distortion level before compensated

Load (%)	THD _v (%)	THD _i (%)	Pf
50%	5.85	16.56	0.94
60%	6.17	16.52	0.94
70%	6.60	16.49	0.94
80%	6.89	16.46	0.94
90%	6.94	16.43	0.94
100%	6.99	16.38	0.94

Table 4.3: Total Harmonic distortion level after compensated

Load (%)	THD _v (%)	THD _i (%)	Pf
50%	0.28	0.28	0.98
60%	0.28	0.29	0.98
70%	0.27	0.31	0.98
80%	0.27	0.32	0.98
90%	0.27	0.35	0.98
100%	0.26	0.36	0.98

In both cases, we can see that the voltage THD decreases while the current THD increases with increases the load.

Harmonic Evaluation

According to the IEEE-519 standards, THD_v at point of common coupling is limited to 5%. To determine THD_i, we need to calculate the ratio of short circuit current and full load current. The short circuit and the full load currents are determined as follows:

PQ Control of AALRT Power Supply System using SVC & Harmonic Filter

For 2MVA transformer capacity with percentage impedance of 8% and 0.59KV secondary voltage, the currents are determined as:

$$I_{FL} = \frac{\text{Transformer (KVA)}}{\sqrt{3} \times \text{secondary voltage}} = \frac{2000\text{KVA}}{\sqrt{3} \times 590\text{V}} = 1.957\text{KA}$$

$$I_{Sh} = \frac{\text{Full load Curret}}{\% \text{ impedance}} = \frac{1.957\text{KA}}{0.08} = 24.46\text{KA}$$

Therefore, the ratio of the short circuit current to full load current becomes:

$$\frac{I_{Sh}}{I_{Fl}} = \frac{24.46\text{KA}}{1.957\text{KA}} = 12.5$$

The individual harmonic distortion evaluation for voltage and current waveform can be performed with a direct observation of the simulated results that is presented in the following table and making limit compliance test with the recommended IEEE 519-1992 limits for individual THD.

Table 4.4: comparisons of THD of voltage and current simulation result at PCC without and with SVC and Harmonic mitigation

h	THD % of Voltage		THD% of current	
	Without SVC &Harmonic filter	With SVC &Harmonic filter	Without SVC &Harmonic filter	With SVC &Harmonic filter
11	4.54%	0.03	13.51%	0.01
13	3.67%	0.03	9.15%	0.01
23	0.61%	0	0.79%	0
25	0.55%	0	0.64%	0

Now applying IEEE 519-1992 recommended limits for current distortion with $\frac{I_{sh}}{I_L} < 20$ table 4.4 results shown that 11th, 13th, 23th and 25th fail to satisfy the standard value set for THDi 4%, 2% and 0.6% respectively.

CHAPTER FIVE

CONCLUSION AND RECOMMENDATION

5.1. Conclusion

In this paper, the various power quality issues are discussed. It mainly gives solutions to harmonic distortion and power factor using SVC and harmonic filter. Here, investigations are carried out with and without SVC and harmonic filter at the PCC. It is clear the results that traction load has increased the total harmonic distortion in feeding bus.

In general, current and voltage distortion have been varied with position of electric tram, the load characteristics of the tram and the train traffic. From the simulation result obtained in chapter 4, it can be conclude that the % THD of current at the PCC increase as the load increase. During simulation in worst case scenario for voltage distortion at PCC a THD of 6.99% was observed, which 28.45% above the recommended limit of IEEE (5%). In addition to this, individual current distortion of the most dominant harmonic orders is high and violates the recommended limit of IEEE 519.

Integration of SVC and Harmonic filter has the advantage of improving the traction substation power factor. In this thesis it is shown that the power factor is improved from 0.94 to 0.98 by controlling the harmonic distortion of the rectifier.

Finally, from the result obtained it can be conclude that to ensure power quality the proposed SVC and harmonic filters performed best in fulfilling of the objective of the study.

5.2. Recommendation

To maintain power quality of the existing AALRT traction system, one of the major issues to address should be the issue of power quality problem. In this regard the Ethiopian Railway Corporation (ERC).Accordingly, it is possible to reduce the adverse effects of power quality problems on the grid and traction equipment.

REFERENCES

- [1]. Rekha T, Dr. Bisharathu Beevi A, "Power Quality Control in DC Traction System by Using Static VAR Compensator and Harmonic Filter", Vol.3, Oct.2014
- [2]. S.H. Hosseini, F. Shahnia, M. Sarhangzadeh, E. Babaei, "Power Quality Improvement of DC Electrified Railway Distribution Systems Using Hybrid Filters", in Proc. Electrical Machine and Systems. 2005. ICEMS 2005. Vol.2.No.2.pp.1273-1277, Oct.2005.
- [3]. R.C. Dugan, M.F. McGranaghan, "Electrical Power System Quality," 2nd Edition, McGraw-Hill, 2002
- [4]. R. Sastry Vedam Mulukutla S. Sarma, "Power Quality VAR Compensation in power Systems", CRC Press, 2009 by Taylor & Francis Group. LLC
- [5]. Ethiopian Railway Corporation, "Addis Ababa Light Rail Transit Project", Overview of system design, 2012
- [6]. L. Battistelli, P. Caramia, G. Carpinelli, D. Porto. "Power Quality Disturbance Due to interaction between AC and DC Traction Systems". IET International Conference on Power Electronics, Machines and Drives PEMD. Vol.2 pp. 492-497, 2004
- [7]. IEEE Std. 519-1992, IEEE Recommended Practices and Requirements for Harmonic Control in Electrical Power Systems.
- [8]. IEEE Std. 141-1993, IEEE Recommended Practices for Electrical Power Distribution for Industrial Plants
- [9]. N.G. Hingorani, L. Gyugyi "Understanding FACTS Concepts and Technology of Flexible AC Transmission Systems", Wiley IEEE Press 1999
- [10]. R. Takagi, S. Sone, "More Intelligent DC Railway Electrical Power Systems with power Traction Control" Electrical Engineering in Japan, Vol.114, No.7, pp. 91-101, 1994
- [11]. Demissu Legese, "Harmonic Analysis of Light Rail Transit Traction Converter", August 2014.
- [12]. A. J. Ghanizadeh, S. H. Hosseinian, G. B. Gharehpetian, "Harmonic Disturbance Compensating and Monitoring in electric traction system", Vol.2 No 3, ELELIJ August 2013
- [13]. Guriqbal Singh, "Electrical power quality-Issues, Effects and Mitigation", Vol. 2 Issue 6, June-2013.

PQ Control of AALRT Power Supply System using SVC & Harmonic Filter

- [14]. Manjulata Badi, “Power Quality Improvement using passive shunt filter, TCR and TSC combination”, May 2012.
- [15]. Yamini Arora, “A Review of Power Quality Problems and its Solution at Distribution end and Distributed Generation”, Issue 4, Vol.5, Aug-Sep. 2014.
- [16]. Mridula Sharma, Manish Soni, “Review of Power Quality issues for Traction System”, Volume 3, Issue 8, August 2013.
- [17]. M.Chymera, A.C.Renfrew & M.Barnes, “Railway modeling for power quality analysis” Vol. 88. 2006 WIT press.
- [18]. T. Chaikulwora, “Optimizing AC Electrical Railway Power flows with Power electronic Control”, University of Birmingham, November 2003
- [19]. TheMathWorks, Inc., User’s Guide, Ver. 1, 1999. <http://www.mathwork.com>.
- [20]. Ali Bekir Yildiz, “Equivalent Circuit Model Containing AC and DC Side Harmonics and Rectifier Circuits”, 4th International Conference on Power Engineering, Energy and Electrical Drives, Istanbul, Turkey, 13-17 May 2013.
- [21]. Hazem Zubi, “Low Pass Broadband Harmonic Filter Design”, *Middle East Technical University*, September 2005.
- [22]. Ali Bekir Yildiz, Ezgi Unverdi Aglar, “Harmonic Modeling of Full-Wave Diode Rectifier for non-uniform load currents”, vol.44, N0.4 (2014).
- [23]. Mihaela Popescu, Alexandru Bitoleanu and Mirceanu Dobriceanu, “ Harmonic Current Reduction in Railway Systems”, University of Craiova, Issue 7, vol.7, July 2008
- [24]. H.B. Nagesh and P.S.Puttaswamy, “Power Flow model of Static VAR Compensator and Enhancement of Voltage Stability”, *International Journal of Advance in Engineering & Technology*. May 2012.
- [25]. Burak Kurdak, “A single phase PLL based active filter solution for power quality problems in railway electrification systems using scott transformer”, 2010.
- [26]. Gonzalo Sandoval, “ Power Factor in Electric Systems with Nonlinear loads”
- [27]. ABB, “Modeling of SVC in Power System Studies”, 1996.

Appendix A: Parameter Determination

The power network that provide supply for the railway substations have a transformer with capacity of 25MVA, impedance percentage 10% and 132 KV/15KV.

The transformer's rated current is found as:

$$I_{rated} = \frac{KVA_{transformer}}{\sqrt{3} \times V_{secondary}} = \frac{25 MVA}{\sqrt{3} \times 15KV} = 962.25 A$$

The transformer's short circuit current is:

$$I_{sc} = \frac{I_{rated}}{\% Impedance} = \frac{962.25A}{0.1} = 9622.5A$$

The short circuit capacity MVA,

$$MVA_{sc} = \sqrt{3} V_{sec} I_{sc} = \sqrt{3} \times 15000 \times 9622.5 MVA = 250 MVA$$

$$Z_{sec} = \frac{V_{sec}^2}{MVA_s} = \frac{(15KV)^2}{250 MVA} = 0.9\Omega$$

Rectifier Transformer Parameters

The Traction Rectifier Transformer parameters are determined from the short circuit and open circuit data.

From the short circuit data the magnitude of the series impedance referred to the primary side of the transformer is calculated. The magnitude of the series impedance referred to primary side is given by:

$$Z_{eq} = \frac{V_{sc}}{I_{sc}}$$

$$Z_{eq} = R_{eq} + jX_{eq}$$

$$Z_{eq} = (R_p + a^2 R_s) + j(X_p + a^2 X_s)$$

PQ Control of AALRT Power Supply System using SVC & Harmonic Filter

$V_{oc} = 15KV$	$Z_{sc} \% = 8$ $pf = 0.9$
$I_{oc} = 0.5\% I_n = 9.785A$	Primary voltage = 15KV
Transformer rating= 2000KVA, 1600KVA	Secondary voltage = 590V

Using the rated transformer data and percentage of impedance:

$$I_{Fl} = \frac{\text{Transformer KVA}}{\sqrt{3} \times \text{Secondary voltage}} = \frac{2000 \text{ KVA}}{\sqrt{3} \times 590} = 1.957KA$$

$$I_{sc} = \frac{I_{Fl}}{Z\%} = \frac{1.957KA}{0.08} = 24.46 \text{ KA}$$

$$V_{sc} = \frac{V_{prim} \times Z\%}{100} = \frac{15000 \times 8}{100} = 1200 \text{ V}$$

$$Y_E = \frac{I_{oc}}{V_{oc}} = \frac{9.785}{15KV} = 6.523 \times 10^{-4}$$

$$Z_E = \frac{V_{sc}}{I_{sc}} = \frac{1200 \text{ V}}{24.46KA} = 0.049$$

$$I_{Fl} = \frac{\text{Transformer KVA}}{\sqrt{3} \times \text{Secondary voltage}} = \frac{1600 \text{ KVA}}{\sqrt{3} \times 590} = 1.57KA$$

$$I_{sc} = \frac{I_{Fl}}{Z\%} = \frac{1.57KA}{0.08} = 19.625 \text{ KA}$$

$Y_E = 6.523 \times 10^{-4}$	$R_c = 1613W$	$X_m = 4909.65W$
$Z_E = 0.04906$	$R_E = 0.0466 \text{ W}$	$X_{eq} = 0.0153W$

The per-unit conversion

$$Z_{base} = X_{base} = R_{base} = \frac{(15000V)^2}{2000KVA} = 112.5W$$

$$L_{base} = \frac{X_{base}}{2\pi f_o} = \frac{112.5}{2\pi \times 50} = 0.358H$$

$$R_{(pu)} = \frac{R}{R_{base}} \text{ (W)}, \quad L_{(pu)} = \frac{L}{L_{base}} \text{ (W)}$$

PQ Control of AALRT Power Supply System using SVC & Harmonic Filter

Assuming that the two secondary windings are identical and each parameters of the secondary is half of the primary winding. Per unit values are calculated:

$R_{m(pu)} = 14.34$	$X_{m(pu)} = 43.64$
$R_1 = \frac{R_{eq}}{2} = 0.0233$	$X_1 = \frac{X_{eq}}{2} = 0.0077$
$R_2 = R_3 = \frac{R_1}{2} = 0.01165$	$X_2 = X_3 = \frac{X_1}{2} = 0.00385$

Appendix B: IEEE 519-1992 Power Quality Standards

The requirements of voltage distortion and current distortion of IEEE 519 harmonic standard are given below.

Table B.1: Current Distortion limits for general distribution systems (120 V through 69 KV)

Maximum Harmonic Current Distortion in Percentage of I_L						
Individual Harmonics Order (Odd Harmonics)						
I_{sc}/I_L	$h < 11$	$11 \leq h < 17$	$17 \leq h < 23$	$23 \leq h < 35$	$35 \leq h$	TDD
< 20	4.0	2.0	1.5	0.6	0.3	5.0
20 - 50	7.0	3.5	2.5	1.0	0.5	8.0
50 - 100	10.0	4.5	4.0	1.5	0.7	12.0
100 - 1000	12.0	5.5	5.0	2.0	1.0	15.0
> 1000	15.0	7.0	6.0	2.5	1.4	20.0

Table B.2: Shows the IEEE 519-1992 recommended voltage distortion limits

Bus Voltage at PCC	Individual Voltage Distortion (%)	Total Voltage Distortion THD_v (%)
69 KV and below	3.0	5.0
69 KV through 161 KV	1.5	2.5
161.001 KV and Above	1.0	1.5