



Influence of Rail Vehicle Parameters on Lateral and Vertical Accelerations of a Passenger Rail Vehicle

A Thesis Submitted to the School of Graduate Studies of Addis Ababa University in
Partial Fulfillment of the Requirements for the Degree of Masters of Science in
Rolling Stock Engineering (Mechanical Engineering)

Fiseha Mengisteab

School of Graduate Studies of Addis Ababa University, Addis Ababa Institute of
Technology, School of Mechanical and Industrial Engineering
Master's program Sponsored by Ethiopian Railways Corporation, 2012 -2014

Advisors:

Zewdu Abdi (Dr.-Ing)

Tolossa Deberie (M.Sc.)

August, 2014

DECLARATION

I declare that this piece of work is my own and all sources of materials used for this thesis work have been duly acknowledged. The thesis has been submitted in partial fulfillment of the requirements for the degree of Master of Science at Addis Ababa University and is reserved at the University Library to be made available to users. I truly declare that this thesis work is not submitted to any other institution anywhere for the award of any academic degree, diploma, or certificate. With accurate acknowledgment of the source, users are free to use this thesis without special permission.

Name: Fiseha Mengisteab Signature: _____ Date: _____

As thesis research advisor, I hereby approve that I have read and evaluated this thesis prepared, under my guidance, by Fiseha Mengisteab, entitled “Influence of Rail Vehicle Parameters on Vertical and Lateral Accelerations of a Passenger Rail Vehicle”. I recommend it be submitted as fulfilling the thesis requirement.

Name of advisor

Signature

Date

ADDIS ABABA UNIVERSITY
SCHOOL OF GRADUATE STUDIES
ADDIS ABABA INSTITUTE OF TECHNOLOGY
SCHOOL OF MECHANICAL AND INDUSTRIAL ENGINEERING

Approval of Board of Examining:

_____	_____	_____
Name of Chair person,	Signature	Date

_____	_____	_____
Name of Advisor	Signature	Date

_____	_____	_____
Name of Internal Examiner	Signature	Date

_____	_____	_____
Name of External Examiner	Signature	Date

ACKNOWLEDGMENTS

Conducting this thesis research from thesis proposal preparation, data collection, and to the final write up of the thesis could have not been fruitful if it were not for a generous assistance of individuals, institutions and numerous researchers who have made contributions to the literatures in this field. The researcher is extremely indebted to advisors Dr.Ing Zewdu Abdi and Mr. Tolossa Deberie for their willingness to supervise the research. In addition, encouragement, guidance, valuable comments and supply of necessary materials and information during all stages of the work that were freely rendered by them are greatly appreciated. So the researcher would like to extend deepest gratitude to them for their continuous technical support and commitment throughout the research. Without the encouragement, insight and guidance of the advisors, the completion of this work would have not been possible. Thanks are also due to Addis Ababa institute of technology and Ethiopian Railways Corporation.

ABSTRACT

This paper presents parametric analysis study of the influence of rail vehicle parameters on vertical and lateral car body accelerations. Vehicle parameters such as bogie wheel base, primary and secondary suspension parameters, car body mass, car body yaw, pitch and roll mass moment of inertias have been studied by varying from -25% to +25% of their original values. The analysis was conducted by modeling and simulating 41 DOF passenger rail vehicle using SIMPACK, multibody dynamics simulation software. The considered vehicle was a conventional rail vehicle with typical measured rail irregularities from SMPACK model data base. The parametric analysis results, in the human ride sensitivity frequency ranges i.e. 0.5-2Hz for lateral and 5-10Hz for vertical accelerations according to ISO 2631, showed that car body mass, car body pitch mass moment of inertia, secondary suspension vertical damping, secondary suspension vertical stiffness, primary suspension vertical damping, primary suspension vertical stiffness and wheel base were sensitive parameters influencing vertical car body acceleration. While lateral acceleration of the vehicle was influenced by car body mass, car body roll & yaw mass moment of inertias, and secondary suspension lateral stiffness & damping, primary suspension lateral stiffness & damping and wheelbase. The analysis was validated by comparing with experimental results. The study will give vital information to designers in optimization of rail vehicles.

Keywords: Parametric analysis; Vehicle acceleration, Vertical ride; Lateral ride; Ride comfort, Ride behavior

TABLE OF CONTENTS

DECLARATION	ii
ACKNOWLEDGEMENT	iv
ABSTRACT	v
LIST OF FIGURES	viii
LIST OF TABLES	ix
NOMENCLATURE	x
CHAPTER 1: INTRODUCTION	1
1.1. Background	1
1.2. Significance of the research	4
1.3. Objective, Scope and limitations of the study	5
1.4. Organization of the paper	7
CHAPTER 2: LITERATURE REVIEW	8
2.1. Theoretical review	8
2.1.1. Multibody system dynamics	8
2.1.2. Computer implementation and tool	11
2.1.3. Rail way systems and ride behavior	13
2.1.4. Modeling and simulation using SIMPACK	15
2.1.5. Human body sensitivity to car body accelerations	19
2.2. Review of researches related to the current study	20
2.2.1. Introduction	20
2.2.2. Summary	24
2.2.3. Research gaps and conclusion	24
CHAPTER 3: MATERIALS, METHODS AND CONDITIONS	25
3.1. Materials	25
3.2. Conditions	25
3.3. Methods	26

CHAPTER 4: RESULTS AND DISCUSSIONS	36
4.1. Results	36
4.1.1. Validation of simulation results	37
4.2. Discussions	39
4.2.1. Influence of car body parameters on vehicle vertical and lateral accelerations	40
4.2.2. Influence of secondary suspension parameters on vehicle vertical and lateral accelerations	44
4.2.3. Influence of primary suspension parameters on rail vehicle vertical and lateral accelerations	48
4.2.4. Influence of bogie wheel base on vertical and lateral accelerations	52
CHAPTER 5: CONCLUSIONS, RECOMMENDATIONS AND FUTURE WORKS	53
5.1. Conclusions	53
5.2. Recommendations	54
5.3. Future works	55
REFERENCES	56
APPENDICES	59
Appendix A. Vehicle design data	59
A.1 Rail vehicle	59
A.2 Conventional bogie	59
Appendix B. Track data	63
B.1 Rail excitation	63
Appendix C. Wheel rail data	64
C.1 Rail	64
C.2 Wheel	65
C.3 Wheel rail contact data	66
Appendix D. Parametric analysis results	67

LIST OF FIGURES

Figure 2.1: Side and top views of a bogie rail vehicle	10
Figure 2.2: Rail way vehicle as an example of a physical system	12
Figure 2.3: Mechanical model - rail vehicle	13
Figure 2.4: 2D Line Plot (vertical acceleration of car body)	14
Figure 3.1: Flow chart of the simulation procedure	22
Figure 3.2: Model of rail vehicle using SIMPACK	23
Figure 3.3: Kinematic model of rail vehicle	25
Figure 3.4: Wheel rail interaction model	27
Figure 4.1: Car body vertical and lateral accelerations	31
Figure 4.2: PSD of vertical acceleration (in $(\text{m/s}^2)^2/\text{Hz}$) of car body from tests	33
Figure 4.3: PSD of lateral acceleration (in $(\text{m/s}^2)^2/\text{Hz}$) of car body from tests	34
Figure 4.4: Parametric analysis results of car body mass	36
Figure 4.5: Parametric analysis results of car body roll mass moment of inertia	37
Figure 4.6: Parametric analysis results of car body pitch mass moment of inertia	38
Figure 4.7: Parametric analysis results of car body yaw mass moment of inertia	39
Figure 4.8: Parametric analysis results of secondary spring lateral stiffness	40
Figure 4.9: Parametric analysis results of secondary spring vertical stiffness	41
Figure 4.10: Parametric analysis results of secondary damper lateral damping	42
Figure 4.11: Parametric analysis results of secondary damper vertical damping	43
Figure 4.12: Parametric analysis results of primary spring lateral stiffness	44
Figure 4.13: Parametric analysis results of primary spring vertical stiffness	45
Figure 4.14: Parametric analysis results of primary damper lateral damping	46
Figure 4.15: Parametric analysis results of primary damper vertical damping	47
Figure 4.16: Parametric analysis results of bogie wheel base	48

LIST OF TABLES

Table A.1: Rigid body design data	55
Table A.2: Bogie frame dimensions	55
Table A.3: Suspension design data	56

NOMENCLATURE

DAE	Differential Algebraic Equations
DOF	Degrees Of Freedom
FFT	Fast Fourier Transformation
ISO	International Standards Organization
MBS	Multibody System
ODE	Ordinary differential Equations
PSD	Power Spectral Density
UIC	Union of International Railways
x	Longitudinal motion
y	Lateral motion
z	Vertical motion
χ	Pitch motion
φ	Roll motion
ψ	Yaw motion

CHAPTER 1

INTRODUCTION

1.1. Background

[24] The history of rail transport, including systems with man or horse power, and tracks or guides made of stone or wood, dates to as early as Greek times. The first trains were single wagons pushed or pulled by people or animals, and were used to move goods, such as coal. Steam trains were the first type of trains. They use coal in a firebox to boil water until it turns to steam. The steam is forced through powerful pistons to give the engine the power to drive the wheels. At first, steam engines moved mainly goods, but were soon used to carry passengers as well. Steam engines are still in use all over the world, although most have been replaced by diesel or electric trains. Diesel locomotives were first introduced in Australia in the 1930's. They were a powerful addition to the railways. Diesel fuel powers an engine which drives a generator to make electricity. The electricity powers traction motors that turn the wheels. Diesel locomotives are used to transport enormous quantities of materials over huge distances. They are also more efficient and smoother than steam trains, and carry much heavier loads.

Passenger electric trains were first introduced in the late 1870's. The electric engines get their power from overhead wires or through an extra third rail. However, building an electric line is expensive so these trains are usually found in city areas where the route is busy enough to pay for the expensive setup. Electric trains are faster, quieter, and simpler to run than the diesel train. Electric trains are also better for the environment as they do not discharge exhaust fumes. Maglev trains do not use an engine to power them; instead they run in a guide way with magnets in the track ahead of them that move them along.

Maglev trains are smooth, fast and environmentally friendly giving off little noise or exhaust pollution. However, the track is expensive and there are problems moving the trains from one track to another.

[25] Railway lines construction in Ethiopia was first started in October 1897 from Djibouti in the period of Emperor Menelek II. The first commercial service began in July 1901, from Djibouti to Dire Dawa. By 1915 the line reached Akaki, 23 kilometers from the capital, and two years later came all the way to Addis Ababa. The railway links Addis Ababa, the capital of landlocked Ethiopia, to the port of Djibouti in coastal Djibouti. Maintenance shops along the line are located in Dire Dawa, which grew up as the Imperial Ethiopian Railway depot for nearby Harar. The single track 781 km railway has a 1,000 mm (3 ft 3 $\frac{3}{8}$ in) gauge, most of it on Ethiopian territory, and about 100 km in Djibouti.

The railway transport system is one of the most crucial transport systems in the world with very high speed, safety and durability. Now a days, there is a high demand on railway transportation system in the world including in our country Ethiopia for long distance transportation of passengers and goods.

Transportation performance indices such as speed, ride quality, capacity, transportation cost, safety etc. are competition parameters among and within transportation modes. In order to be competitive and successful in transportation services thus rail operators are demanding and expending a lot of expenditure in design, research and development of high performance rail vehicles. Rail transportation has been the most demanded transportation offering better safety, speed and comfort. In parallel with implementation of new technologies, the cruising speed has also increased, with reliable safety and better ride comfort. Traffic road block, huge mass transportation and so on bring a good opportunity for rail industries to attract more and more passengers and cargos to their services. In addition to safety, the other important issue for passengers to decide about transportation type is ride comfort during their journey.

The effect of vibration caused by rail disturbances on vehicle car body and passengers are more important in high cruising speeds. Hence, safe and comfortable transportation of passengers and goods under high speeds has become an important engineering problem to solve. Various studies have been performed on rail vehicle dynamics and rail vehicle system vibrations in the last decades. The studies generally focused on dynamic modeling of rail vehicle systems such as rail–sleeper–ballast models and bridge–rail–vehicle interactions. In addition, some researchers dealt with rail vehicle dynamics and effect of rail disturbances on multi-body modeling of rail way vehicles. Furthermore, there are some researches which dealt with experimental and analytical ride comfort evaluation of railway coaches, methods for reducing vertical car body vibrations of rail vehicles, improvement of passengers ride comfort in rail vehicles etc.

The methods presented in the literatures were two dimensional mathematical modeling of rail way vehicle systems formulated using Lagrangian equation of motion and multibody system dynamics approach and implemented using user developed mathematical models and solution algorithms.

But the researches had some limits that reduce their suitability in a reliable and efficient simulation of the dynamics of a rail way system, because they are based on arbitrary and simplified assumptions, such as:

- assigning an arbitrary excitation
- neglecting nonlinear behaviors
- not considering all the degrees of freedom of the vehicle

In addition, there are research gaps in addressing the contribution of each component of the track vehicle parameters on rail vehicle acceleration.

1.2. Significance of the research

Performance of a rail vehicle depends on its dynamic behavior and dynamics of rail vehicles involve coupled motion of each of the track vehicle system components; therefore, it is affected by the design of all track vehicle system components. Hence; modeling and simulation in the field of rail way dynamics is a complex interdisciplinary topic with necessity for the enhancement of the performance of the rail way vehicles and obtaining more safety and comfort conditions which lead to more complex definition and description for all parameters affecting the modeling and simulation of railway track vehicle system.

Car body peak accelerations are one cause of discomfort in passenger rail vehicles and the accelerations are, mainly caused by track irregularities, transmitted up to the car body via bogies, therefore; to achieve good ride comfort these accelerations have to be suppressed. To improve ride comfort it is important to have better understanding on vehicle track parameters influencing ride behavior which needs conducting parametric analysis of track vehicle parameters on ride behavior which provides to rail vehicle designers vital information regarding the extent to which each parameter influences the acceleration response of the vehicle. This information can also be utilized to arrive at a suitable combination of the design parameters which can aid in keeping the peak value of accelerations within the standard comfort boundaries which results in an improved ride. Therefore; parametric analysis of rail vehicle parameters influencing ride behavior using efficient and validated multibody system simulation software simulates closely the real world rail vehicle system dynamics and gives better input for understanding and design of rail vehicles at low cost.

1.3. Objective, Scope and Limitations of the Study

General objective

The primary aim of this research was to conduct parametric analysis of a passenger rail vehicle parameters influence on ride behavior, mainly car body acceleration, using SIMPACK multibody simulation software, i.e. a passenger rail car was modeled and simulated for constant velocity of 25m/s over straight track of length 10Km using SIMPACK software to get car body vertical and lateral accelerations. In addition, rail vehicle parameters such as car body mass, car body mass moment of inertias, primary suspension, secondary suspension and wheel base were varied to study the influence of each parameter on lateral and vertical car body accelerations.

Specific objectives

The specific objectives of the study were:

- Study multi-body system dynamics software, SIMPACK
- Model a two bogie passenger rail vehicle using SIMPACK
- Simulate the vehicle using a constant velocity of 25m/s over a straight track of length 10Km using SIMPACK software
- Examine software simulation results, i.e. car body lateral and vertical accelerations and validate them with experimental results
- Conduct parametric analysis by varying rail vehicle parameters and study the influence of each parameter on car body lateral and vertical accelerations

Scope

The study focuses on conducting parametric analysis of a passenger rail vehicle by modeling the vehicle and conducting parametric analysis using SIMPACK software to examine rail vehicle parameters influence on car body vertical and lateral accelerations.

The vehicle was simulated using a constant velocity of 25m/s on a rigid straight track of length 10Km and the vehicle parameters varied during the study are:

- bogie wheel base
- vertical & lateral stiffness values of primary and secondary suspensions
- vertical & lateral damping coefficients of primary and secondary suspensions
- car body mass, pitch (I_{yy}), roll (I_{xx}) and yaw (I_{zz}) moments of inertias

Limitations

Due to lack of sufficient data, limitations of the current study are:

- The rail vehicle model used in the simulation study comprises a rigid car body, i.e. car body flexibility was not considered in the current study but it does influence rail vehicle dynamics and it is another engineering problem which needs to be solved
- Track flexibility and mass were not considered in the current study but they do influence rail vehicle dynamics; therefore, the effect of such track parameters on rail vehicle dynamic behavior is another engineering problem which needs to be studied.
- Track geometry, such as horizontal and vertical curves, gauge profile etc., was not considered in the current study but it does influence rail vehicle dynamics; therefore, influence of track geometry on ride behavior is another engineering problem which needs to be studied.
- Effect of wind, traction and braking were not considered in the current study but they do influence rail vehicle dynamics so incorporating traction and braking in rail vehicle dynamics analysis results in better simulation results.
- All wheel profiles were considered identical from left to right on a given axle and from axle to axle and all wheels remains in contact with the rails as well as no wheel flats was considered but in practice all wheel profiles are not identical, there are wheel lifts and wheel flats which influence ride dynamics; hence, consideration of such things will give better result.

1.4. Organization of the paper

The thesis report comprises 5 chapters and the remainder of the thesis is organized as follows. Chapter 2 presents review of related research works done and theoretical literatures relevant for the study such as:

- multibody system dynamics, rail vehicle dynamics modeling and simulation
- ride behavior of rail vehicles
- ride sensitivity of human body to car body accelerations at different frequencies

In chapter 3, the research methodology such as materials, methods and simulation condition are presented. Chapter 4 presents results of the analysis and discussion of the analysis results. Moreover, the study is summarized in chapter 5 by presenting conclusions, recommendations and future work directions. Finally, the detail of the data used for the study such as rail vehicle design data, track design data and wheel rail data as well as analysis results are presented in the appendix section.

CHAPTER 2

LITERATURE REVIEW

2.1. Theoretical review

This section presents review of materials relevant for the study such as:

- multibody system dynamics, rail vehicle dynamics modeling and simulation
- ride behavior of rail vehicles
- ride sensitivity of human body to car body accelerations at different frequencies

2.1.1. Multibody system and dynamic analysis

Multibody dynamics is based on classical mechanics and has a long and detailed history. The simplest multibody system is a free particle which can be treated by Newton's equations. D'Alembert considered a system of constrained rigid bodies where he distinguished between applied and reaction forces. A systematic analysis of constrained mechanical systems was established by Lagrange. Modern methods for the dynamic analysis of constrained multibody systems fall into two main categories: differential algebraic equations (DAEs) and ordinary differential equations (ODEs) [15]. DAEs employ a maximal set of variable to describe the motion of the system and use multipliers to model the constraint forces. Pre-multiplying the constraint reaction-induced dynamic equations by orthogonal complement matrix to the constraint Jacobian results in the governing equations as ODEs.

A Multibody system is a system which is an assembly of two or more rigid or flexible bodies (also called elements) imperfectly joined together, having the possibility of relative movement between them. This imperfect joining of the two rigid bodies that makes up a multibody system is called a kinematic pair or joint, or simply a joint. A joint permits certain degrees of freedom of relative motion and prevents or restricts others.

Usually the elements of a multibody system are linked by means of joints. At times, the elements do not have direct contact with one another but rather are interrelated via force transmission elements, such as springs, and shock absorbers or dampers.

Mechanical systems which are comprised of several flexible and rigid interconnected bodies can be modeled as multibody systems. A multi body system simulation describes the dynamic behavior and interaction between the bodies. These simulations can vary from a simple Newtonian particle or a simple rigid body to several flexible complicated elements like aircrafts, automobiles, trains etc. [7, 12, 13 and 14].

Multibody system (MBS) dynamics studies the motion of mechanical systems composed of several rigid or flexible bodies interconnected by joints and subjected to internal or external forces and torques. Those forces can result from both passive elements such as springs, or active components such as electromechanical actuators.

The calculation of the body motion is one of the principal objectives of the dynamic analysis. This type of analysis also provides a process to estimate external forces which depends on the relative position between system components, such as those generated by springs, dampers and actuators. Also external forces which generated as a consequence of the system interaction with the surrounding environment, such as contact and friction forces, are considered. Another significant result provided by this type of analysis, is the calculation of the internal reaction forces, generated in the kinematic pairs.

The first step in many multibody problems consists in describing the system topology in a suitable way for mathematical analysis. The main components of a multibody system are:

- the bodies, characterized by their mass, center of mass location and inertia tensor
- the joints that determine the relative motion between two bodies or between a body and the inertial frame

Several formalisms have been developed so as to automatically obtain the equations of motion of any multibody system. The most basic one relies directly on the Newton-Euler equations. The so called recursive Newton-Euler algorithm allows reducing the computational efforts when relative coordinates are used.

The equations can also be obtained by using the virtual power (or work) principle or by using Lagrange's equations, which consider the system at the energy level. Whatever the formalism, the equation of motion of a multibody system are generally presented in the following form [17, 18, 19]:

$$M(q)\ddot{q} + C(q, \dot{q}, g) = Q(q, \dot{q}, t) + J^T \lambda$$

$$h(q) = 0$$

Where:

M is generalized mass matrix

q is generalized coordinate vector

\dot{q} is time derivative of q

\ddot{q} is second order time derivative of q

C is non linear dynamic vector (gravity, Coriolis, and centripetal effect)

Q is generalized force vector

h is algebraic constraint vector

$J = \frac{\partial h}{\partial q^T}$ is constraint Jacobian matrix

λ is Lagrange multiplier vector

Therefore, multibody dynamics generally implies a set of differential algebraic equations (DAEs), which requires special care to be time integrated.

Dynamic simulation means integration of the resulting linear or nonlinear ODEs or DAEs to obtain the motion trajectories of the rigid bodies, accelerations and contact forces given the inertial properties and the non-contact external loads (forces and moments). In this context, computing the accelerations becomes the central goal in the dynamic simulation problem.

2.1.2. Computer implementation and tool

Various techniques and formulations have led to the implementation of various computer tools and software. A large number of computer codes have been developed by rail way organizations to assist in the design of suspensions and the optimization of track and vehicles. Some of these have been combined into general purpose packages and some examples of those currently in widespread use are given here [3, 6, and 24].

One of the early complete packages, MEDYNA (Mehrkörper-Dynamik) was developed at the German Aerospace Research organization DLR together with MAN and the Technical University of Berlin. MEDYNA was based on a MBS with small rigid body motions relative to a global reference frame which allowed large motions. The linearized kinematic equations of motion for each body are formulated with respect to the global reference frame. SIMPACK was developed later by the same team at DLR and as it was intended for road vehicles and other systems as well as rail vehicles it allowed nonlinear kinematics from the start. The equations of motion are formulated in terms of relative coordinates and can be generated symbolically and numerically in an implicit and explicit form. The kinematics of elastic bodies were developed to allow stress stiffening effects to be taken into account.

ADAMS is one of the most popular dynamic simulation codes worldwide and in 1995 it entered the railway vehicle simulation market as ADAMS/Rail, initially by including wheel–rail contact methods developed by Ned Train and later by licensing the wheel–rail contact elements from MEDYNA.

In the U.S.A the Association of American Railroads (AAR) funded the development of a program to simulate the behavior of a railway vehicle negotiating a curve. This was developed in to the general purpose simulation package NUCARS (New and Untried Car Analytic Regime Simulation). NUCARS has been used to improve the dynamic behavior of the three-piece freight bogie.

The French National Transport Research Institute INRETS developed a multibody simulation code VOCO (Voitureen Courbe) in 1987 with a reference frame that permitted simulation on long curves. The inclusion of friction damping was possible from the beginning because the code was initially used to simulate the Y25 bogie. A commercial version of this named VOCOLIN in 1991 allowed simulation of the wheel–rail contact with a multi-Hertzian approach. A second approach was made by Gimenez et al. and this was incorporated into the code VOCODYM.

In the U.K. British Rail Research developed a number of computer programs to analyze different aspects of railway vehicle dynamic behavior as has been mentioned above. These have been brought together in to one coherent package VAMPIRE which is now supported by AEA Technology Rail.

Real Time VAMPIRE is an interesting development which has been made possible by advances in computer technology and the very high simulation speed possible with VAMPIRE. Track data can be fed into VAMPIRE directly from a track recording coach and the behavior of vehicles on that section of the track predicted in real time. All the typical vehicle dynamics outputs can be generated for the specific vehicle model that has been loaded. This allows derailment risk, passenger comfort, track force, or any other normal output to be produced and these values are available immediately for track engineers to use, for example, in prioritizing maintenance.

In Sweden, modelling of railway vehicles using computers started at ASEA in 1971. Initially, the analysis was carried out in the frequency domain with linear models and then, in 1973, a nonlinear, time-stepping integration program was developed. This program separated lateral and vertical modes and was used in the development of the X15 high-speed test train and the Rc4 locomotive in 1975. In 1992 the development of a new three-dimensional calculation program started and software development was transferred to a new company called DE solver. This new three-dimensional, general computer code, together with all earlier pre-and post-programs became in 1993 the new railway vehicle analysis tool called GENSYs.

Regarding commercial or industrial software, the most used are ADAMS and SIMPACK. SIMPACK software is one of the most used by the railway industry. SIMPACK relies on relative coordinates and on a numerical generation of the equation of motion. It provides a joint library that contains conventional elements such as simple revolute joints, prismatic joints, universal joints, etc., and specific features to deal with railway vehicles. Concerning time integration, SIMPACK provides classical ODEs integrators for unconstrained system and especially developed DAEs solvers for systems implying algebraic constraints [3, 6].

2.1.3. Rail way systems and ride behavior

A rail vehicle often consists of a car body supported by two sets of running gear. In former passenger vehicles and still partly today's freight vehicles, the car body was only supported by single-axle running gear. Modern freight and passenger rail vehicles, in particular for fast or high-speed traffic, are mostly designed as bogie vehicles. The setup of a typical bogie rail vehicle is shown schematically in Figure 2.1, including the coordinate system of the car body and associated motion components. Note that the positive vertical direction is pointing downwards according to International Union of Railways UIC. The vehicle consists of a car body supported by two bogies through secondary suspension. Each bogie consists of a frame and two wheel sets, connected by the primary suspension. Both the primary and secondary suspensions include spring and damper components that vary depending on the vehicle type. Examples of such suspension elements are air springs, coil springs, rubber springs and hydraulic dampers. The type of component is dependent on the vehicle operational task and the desired suspension characteristics. Furthermore; the suspensions include bump stops, delimiting the suspension motions in the vertical and lateral directions.

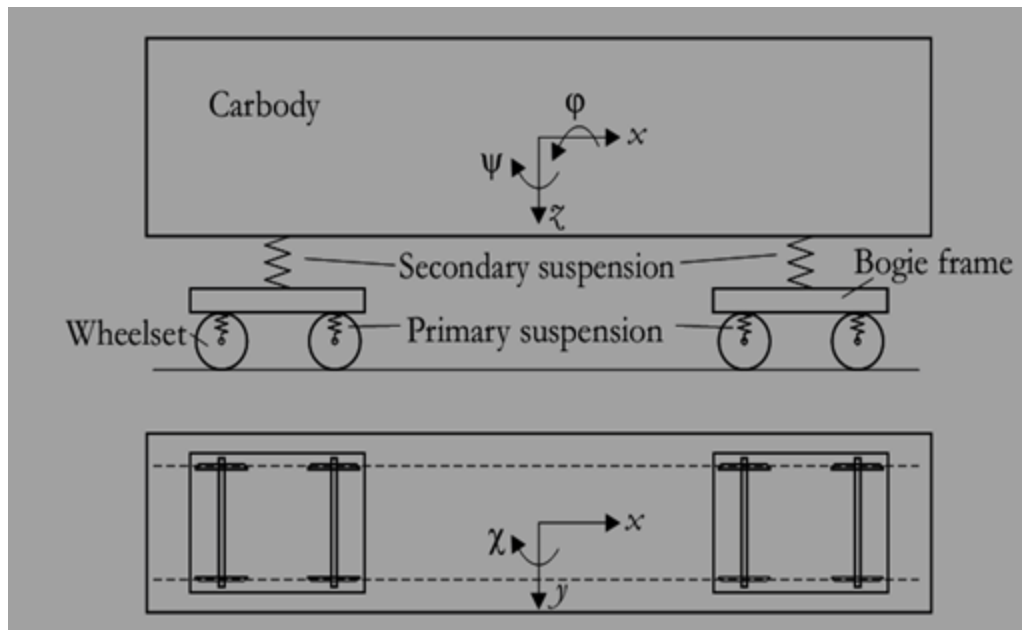

Figure 2.1: Side and top views of a bogie rail vehicle

The force transmission in the longitudinal direction is usually achieved by traction rods. The secondary suspension is often also equipped with one anti roll bar per bogie to counteract the roll motion of the car body. The concept of a bogie vehicle follows the idea of decoupling the car body from the dynamics of the bogies and thus enhancing the running behavior of the carbody. The railway track, the vehicle is running on, has a nominal geometry which is among other things defined by the lateral distance between the two rails, i.e. the gauge. The track, however, is never in perfect condition, but includes deviations from the nominal track geometry, which are also known as track irregularities. These imperfections affect the running dynamics of the vehicle. They influence the motions of the vehicle due to excitations of the wheel sets and generally have great impact on the wheel-rail forces and ride behavior. The ride behavior of rail vehicles is a complex concept, representing an essential element in the analysis of the railway vehicle dynamics and needs to be considered when modeling and evaluating them. Besides other factors, the ride quality primarily depends on the vibration behavior to which the vehicle is subjected.

Moreover; the dynamic behavior of railway vehicles depends on the motion or vibration of all the parts of the vehicle track system and is; therefore, influenced by the vehicle track system design and operating conditions [3].

2.1.4. Modeling and simulation using SIMPACK

The SIMPACK software package is a multibody system mechanical design tool which assists engineers to model, simulate, analyze and design complex mechanical systems, such as vehicles, robots, machines and mechanisms. The software also allows the inclusion of electrical, hydraulic and pneumatic elements. It is also able to analyze vibrational behavior, calculate forces and accelerations as well as describe and predict the motion of multi-body systems. The basic concept of SIMPACK is to create the equations of motion for mechanical and mechatronic systems and then from these equations, apply various different mathematical procedures to produce a solution (e.g. time integration). The SIMPACK model is built up using the SIMPACK modeling elements. SIMPACK will then automatically generate the system equations from this model. The equations of motion can be generated both symbolically and numerically (where the numeric form is the usual form). The software has a comprehensive range of modeling and calculation features, together with a user interface well adapted to an engineer's needs.

The purpose of the software is to improve the design process involving multi-body systems. With the help of SIMPACK it is possible to reduce lead times and optimize the design process. More purposes that can be reached with SIMPACK are:

- Optimization of design parameters also in relation to the dynamic behavior
- Calculation of dynamically interacting forces within critical components
- Effect of varying design parameters
- Analyzing weak points of the mechanical design

From the initial concept stage to the point where SIMPACK has presented the results, there are six steps. The first three steps are performed outside SIMPACK. They are as follows:

1. Problem definition
 - Physical system is defined



Figure 2.2: Rail way vehicle as an example of a physical system [15]

2. Development of a mechanical model
 - Mechanical structure is divided into bodies and joints, the interconnecting structures
 - Constraints are then defined, which constrains the mobility of the elements by removing degrees of freedom
 - Forces in between the ground and the bodies are defined
3. Provision of the physical parameters for the model
 - The physical parameters for the model such as the mass, moments of inertia and center of mass for various different bodies are defined

- The geometry of the structure and how it fits together are defined; i.e. the distances in between coupling points
- The parameters for the coupling elements are defined, such as the force element values and constraints

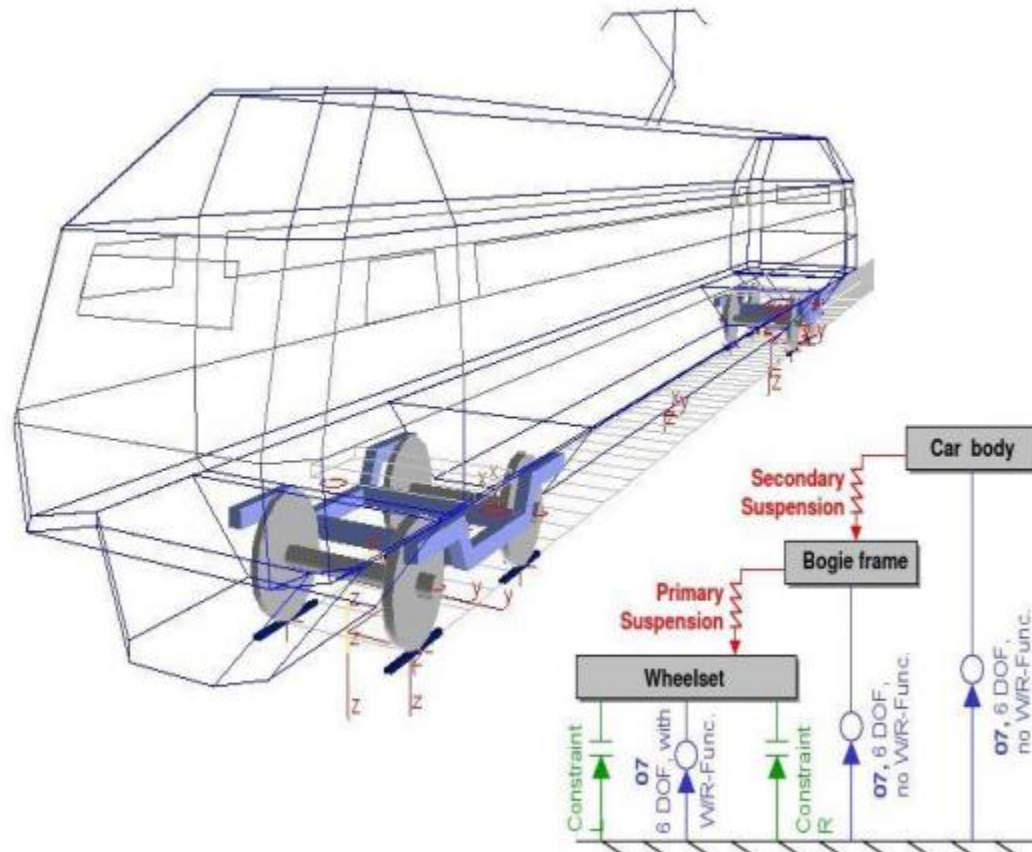

Figure 2.3: Mechanical model - rail vehicle [16]

4. Pre-processing

Input the data set, obtained from steps 1-3, with the help of the SIMPACK user interface:

- The physical model i.e. bodies and joints
- All the input functions for the model including the constraints, forces and excitation functions
- The associated 3D geometrical data for the graphical representation of the bodies
- The numerical calculation settings
- The settings for the output quantities
- The settings for the optimization and parameter variation

5. Problem Solution

SIMPACK Calculations: Generation and solution of the motion governing differential equations. The differential equations are generated from the data entered in the previous steps and then solved within SIMPACK.

6. Post-processing: Presentation of the results

SIMPACK can present the results in any of the following forms:

- User determined plots such as load indices or limiting values
- 2D line plots
- SIMPACK contains various different mathematical algorithms, i.e. Fast Fourier Transforms which can be used to process the results of SIMPACK's calculations
- 3D animation of the model
- Export to Microsoft Excel and MATLAB

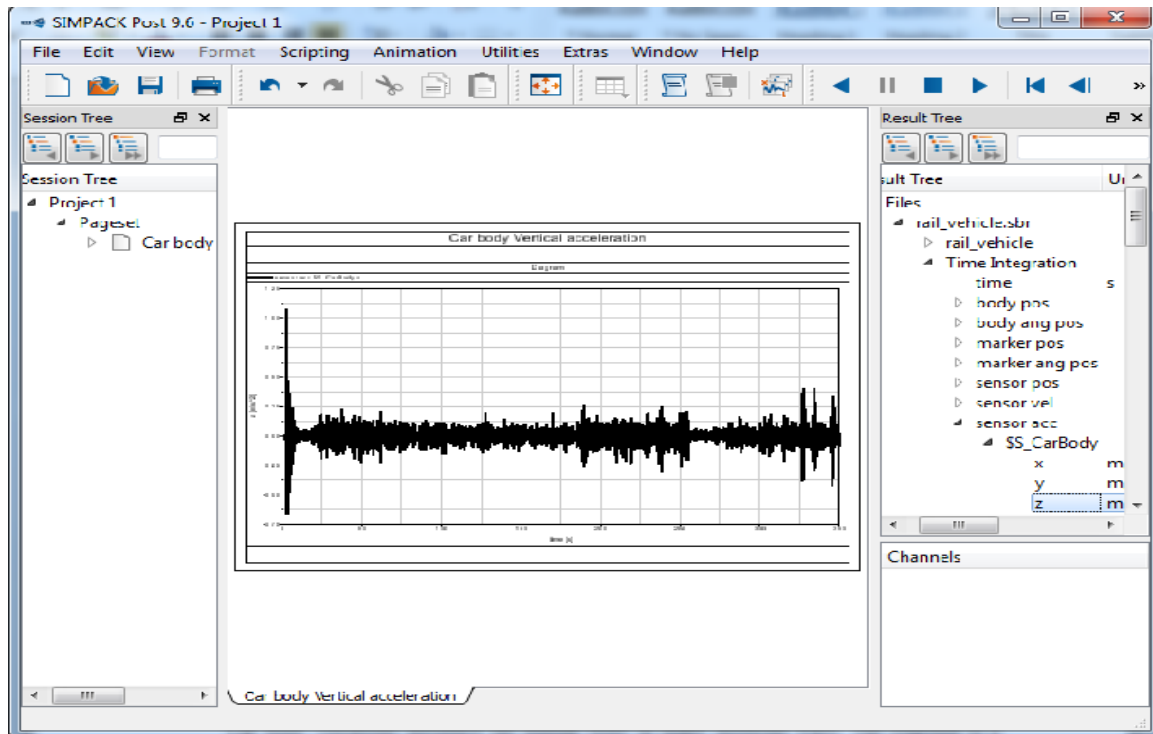

Figure 2.4: 2D Line Plot (vertical acceleration of car body)

2.1.5. Human body sensitivity to car body vibrations

The human body is both physically and biologically a system of an extremely complex nature. When looked upon as a mechanical system it can be considered to contain a number of linear as well as non-linear elements, and the mechanical properties are quite different from person to person. Biologically the situation is by no means simpler, especially when psychological effects are included. In considering the response of man to vibrations and shocks it is necessary, however, to take into account both mechanical and psychological effects.

Car body vibrations influence the human body in many different ways. The response to a vibration exposure is primarily dependent on the frequency, amplitude, and duration of exposure. Other factors may include the direction of vibration input, location and mass of different body segments, level of fatigue and the presence of external support.

The human response to vibration can be both mechanical and psychological. Mechanical damage to human tissue can occur, which are caused by resonance within various organ systems. Psychological stress reactions also occur from vibrations; however, they are not necessarily frequently related. From an exposure point of view, the low frequency range of vibration is the most interesting. Exposure to vertical vibrations in the 5-10 Hz range generally causes resonance in the thoracic abdominal system. When vibrations are attenuated in the body, its energy is absorbed by the tissue and organs. The amount of mechanical energy transmission due to vibrations is dependent on the body position and muscle contractions. In standing subject, the first resonance occurs at the hip, shoulder, and head at about 5Hz. With subjects sitting, resonance occurs at the shoulders and to some degree at the head at 5 Hz. Based on psychological studies, observations indicated that the general state of consciousness is influenced by vibrations. Low frequency vibrations 1-2 Hz with moderate intensities induce sleep.

Generally, according to ISO 2631 ride comfort evaluation, human bodies are considered to be most sensitive to frequency ranges 0.5 – 2 Hz in horizontal direction and 4 – 10 Hz in vertical direction [3, 21, and 23].

2.2. Review of researches related to the current study

2.2.1. Introduction

The ride comfort is a complex concept, representing an essential element in the analysis of the railway vehicle dynamics and needs to be considered when modeling and evaluating its behavior. Besides other factors, the ride comfort primarily depends on the vibration behavior to which the vehicle is subjected. The dynamic behavior of railway vehicles relates to the motion or vibration of all the parts of the vehicle track system and is; therefore, influenced by the vehicle track system design and operating conditions [3].

The dynamic performance of a rail vehicle as related to safety and comfort is evaluated in terms of specific performance indices.

The quantitative measure of ride quality is one of such performance indices. Ride quality is interpreted as the capability of the rail road vehicle suspension to maintain the motion within the range of human comfort and or within the range necessary to ensure that there is no damage to the cargo it carries. The ride quality of a vehicle depends on displacement, acceleration, rate of change of acceleration and other factors like noise, dust, humidity and temperature. Ride comfort implies that the vehicle is being assessed according to the effect of the mechanical vibrations on the human body, whereas ride quality implies that the vehicle itself is being judged [4, 10].

In rail vehicles, air springs are very important isolating component, which guarantee good ride comfort for passengers during their trip [8]. As the performance of suspension components have significant effects on rail-vehicle dynamics and ride comfort of passengers, a complete nonlinear thermo dynamical air spring model, which is a combination of two different models, was introduced. To simulate dynamic behavior of air spring, a model was developed in Matlab/Simulink software. For evaluating performance of the developed model, bogie side states were fixed to constant and response of air spring to sinusoidal movement of carbody side states in vertical and lateral directions were investigated. Result from field test showed remarkable agreement between proposed model and experimental data. Effects of air suspension parameters on the system performances were investigated here and then these parameters were tuned to minimize Sperling ride comfort index during the trip. Results showed that by modification of air suspension parameters, passengers comfort was improved and ride comfort index was reduced by 10%.

In the study [9], a mathematical model of a railway carriage running on curved tracks was constructed by deriving the equations of motion concerning the model in which single point and two point wheel rail contacts were considered. The presented railway carriage model comprises of front and rear simple conventional bogies with two leading and trailing wheel sets attached to each bogie. The railway carriage was modeled by 31 degrees of freedom which govern vertical displacement, lateral displacement, roll angle and yaw angle dynamic response of wheel set whereas vertical displacement, lateral

displacement, roll angle, pitch angle and yaw angle dynamic response of car body and each of the two bogies. Computer aided-simulation was constructed to solve the governing differential equations of the mathematical model using Runge Kutta fourth order method. Principle of limit cycle and phase plane approach was applied to realize the stability and evaluate the concerning critical hunting velocity at which railway carriage starts to hunt. The numerical simulation model was used to study the influence of vertical secondary suspension spring stiffness on the ride passenger comfort of railway car body running with speeds under and at critical hunting velocity. High magnitudes of vertical secondary spring stiffness suspension introduced undesirable roll and yaw dynamic response which affect ride passenger comfort at critical hunting velocity.

A vertical model of metro vehicle which covers car body flexibility and all vertical rigid modes was built [5], the influence of car body flexibility on ride quality and the coupled vibration between the flexible metro vehicle car body and bogie bounce mode were researched. In order to facilitate the research, this paper supposed the car body being simplified as a uniform Euler-Bernoulli beam. Results showed that the higher the car body stiffness is the lower the influences of car body flexibility would be on the ride quality. For the model studied in this paper, the bogie bounce frequency was increased with the rise of the primary suspension stiffness.

Safe and comfortable transportation of passengers and goods on railways can be achieved by solving the vibration problem [2]. In this study, the dynamic modeling of the full railway vehicle was used to perform vibration analysis in order to observe displacements and accelerations. The full railway vehicle model consists of 54 degrees of freedom which were defined by differential equations. Additionally, wheel rail contact problem (i.e. creepage factors and Hertzian spring stiffness of rails) was analyzed by finite element method. Dynamic modeling and vibration analysis were carried out using Matlab/Simulink software. Using the developed model, the car body vibrations, caused by a lateral and two vertical sinusoidal track irregularities, were controlled by fuzzy logic controllers placed between the car body and bogies. The fuzzy logic algorithm here in was used for realizing the active control of car body vibrations.

The simulations of vibration analysis were obtained in time and frequency domains and compared with passive controlled status. The robustness of the designed controller was verified by simulations, carried out for the cases of car body mass variations. The results showed the effectiveness of the proposed algorithm.

This paper [6] investigated the effect of different models for track flexibility on the simulation of railway vehicle running dynamics on tangent and curved track. To this end, a multi body model of the rail vehicle was defined including track flexibility effects on three levels of details: a perfectly rigid pair of rails, a sectional track model and a three dimensional finite element track model. The influence of the track model on the calculation of the nonlinear critical speed was pointed out and it was shown that neglecting the effect of track flexibility resulted in an over estimation of the critical speed by more than 10%. Vehicle response to stochastic excitation from track irregularity was also investigated, analyzing the effect of track flexibility models on the vertical and lateral wheel rail contact forces. Finally, the effect of the track model on the calculation of dynamic forces produced by wheel out of roundness was analyzed, showing that peak dynamic loads were very sensitive to the track model used in the simulation.

In this paper, a complete four axle rail vehicle model was addressed with 70 degrees of freedom (DOFs) including a car body, two bogies, and four axels. In order to include the effects of the track irregularities in vehicle dynamics behavior, a simplified track model was proposed and it was validated by some experimental data and test results. As the performance of the suspension components, especially for air springs, have significant effects on rail-vehicle dynamics and ride comfort of passengers, a complete nonlinear thermo-dynamical air spring model, which is a combination of two different models, was introduced and implemented in the complete rail-vehicle dynamics. By implementing Presthus formulation (Derivation of air spring model parameters for train simulation. The thermo-dynamical parameters of air spring were estimated and then they were tuned based on the experimental data. The results of the complete rail-vehicle field tests, show remarkable agreement between proposed model and test data [11].

2.2.2. Summary

Various studies have been performed on rail vehicle dynamics and rail vehicle system vibrations. The studies generally focused on dynamic modeling of rail vehicle systems such as rail-sleeper-ballast models and bridge-rail-vehicle interactions. In addition, some researchers dealt with the rail vehicle dynamics and the effects of the rail disturbances on multibody modeling of railway vehicles. Furthermore, there were some researches which dealt with experimental and analytical ride comfort evaluation of railway coaches, methods for reducing vertical car body vibrations of rail vehicles, improvement of passengers ride comfort in rail vehicles etc. The methods presented in the literatures were two dimensional mathematical modeling of railway vehicle systems formulated using Lagrangian dynamics and multibody system dynamics modeling approach. Modeling and simulation were implemented using user developed mathematical models and solution algorithms.

2.2.3. Research gaps and conclusion

The researches had some limits that reduce their suitability in a reliable and efficient simulation of the dynamics of a railway vehicle system, because they are often based on arbitrary assumptions, such as not considering all the degrees of freedom of the vehicle i.e. 3D model of the vehicle, and not incorporating nonlinear behaviors as well as assigning arbitrary excitations. In addition, there were research gaps in addressing the influence of each component of the rail vehicle parameters on rail vehicle acceleration. Therefore, parametric analysis of rail vehicle parameters influencing vehicle acceleration using efficient and validated multibody system simulation software can simulate closely the real world rail vehicle system dynamics and will give better input for understanding and design of rail vehicles which is the background for the current study, i.e. parametric analysis of rail vehicle parameters influence on lateral and vertical vehicle accelerations using SIMPACK multibody system dynamics simulation software.

CHAPTER 3

MATERIALS, METHODS AND CONDITIONS

3.1. Materials

a) Rail vehicle

The study was conducted on a conventional passenger rail vehicle shown in figure 3.2. The vehicle consists of a car body, two bogies and four wheel sets. Design data of the vehicle are presented in appendix A.

b) Track

The vehicle was simulated on a rigid and straight standard gauge track of length 10e04m with design characteristics of the track shown in appendix B.

c) Simulation tool

The study was based on computer simulations and analysis of rail vehicles using SIMPACK 9.6 build 93 software. The software is developed at the German aerospace research center (DLR) together with INTEC GmbH, with important practical enhancements added to the software at MAN technology AG, Germany.

3.2. Conditions

The conditions for the simulation were straight and rigid track of length 10Km, equilibrium position and a constant velocity along track, $V = 25\text{m/s}$ as well as the following assumptions:

- Bogie and car body component masses were considered to be rigid
- Friction did not exist between axle and bearing
- Constant and standard gauge track

- All wheel profiles were considered to be identical from left to right on a given axle and from axle to axle and all wheels remains in contact with the rails
- Bogie bolster was assumed as a car body's integral part i.e. combined with its mass
- Axle box was assumed as a wheel set's integral part, hence its weight was combined with the wheel set's mass

3.3. Methods

The procedure of the simulation analysis study in the SIMPACK software is shown in figure 3.1 below.

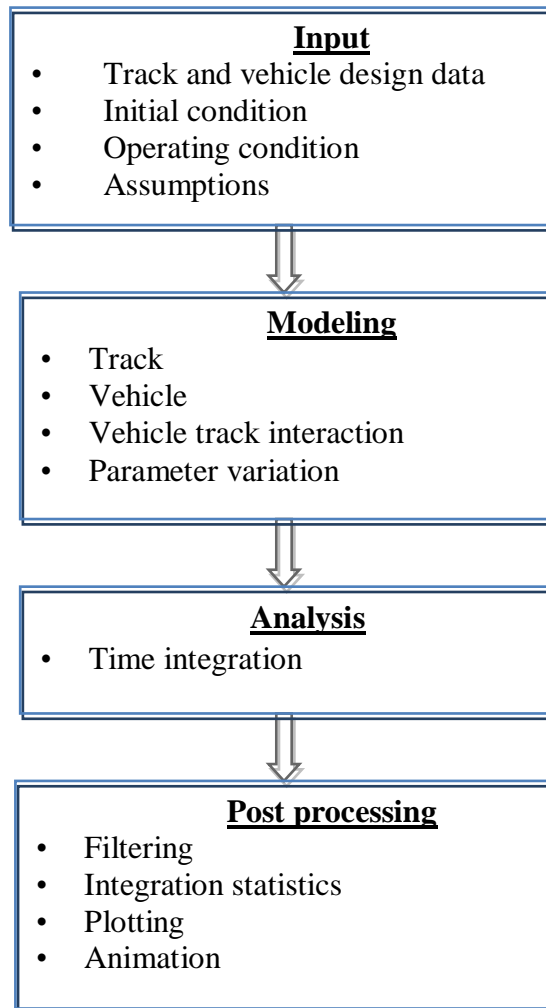

Figure 3.1: Flow chart of the simulation procedure

a) Input

The physical system i.e. the rail vehicle is divided into bodies, joints and force elements. Physical parameters of bodies, joints and force elements are defined along with simulation condition.

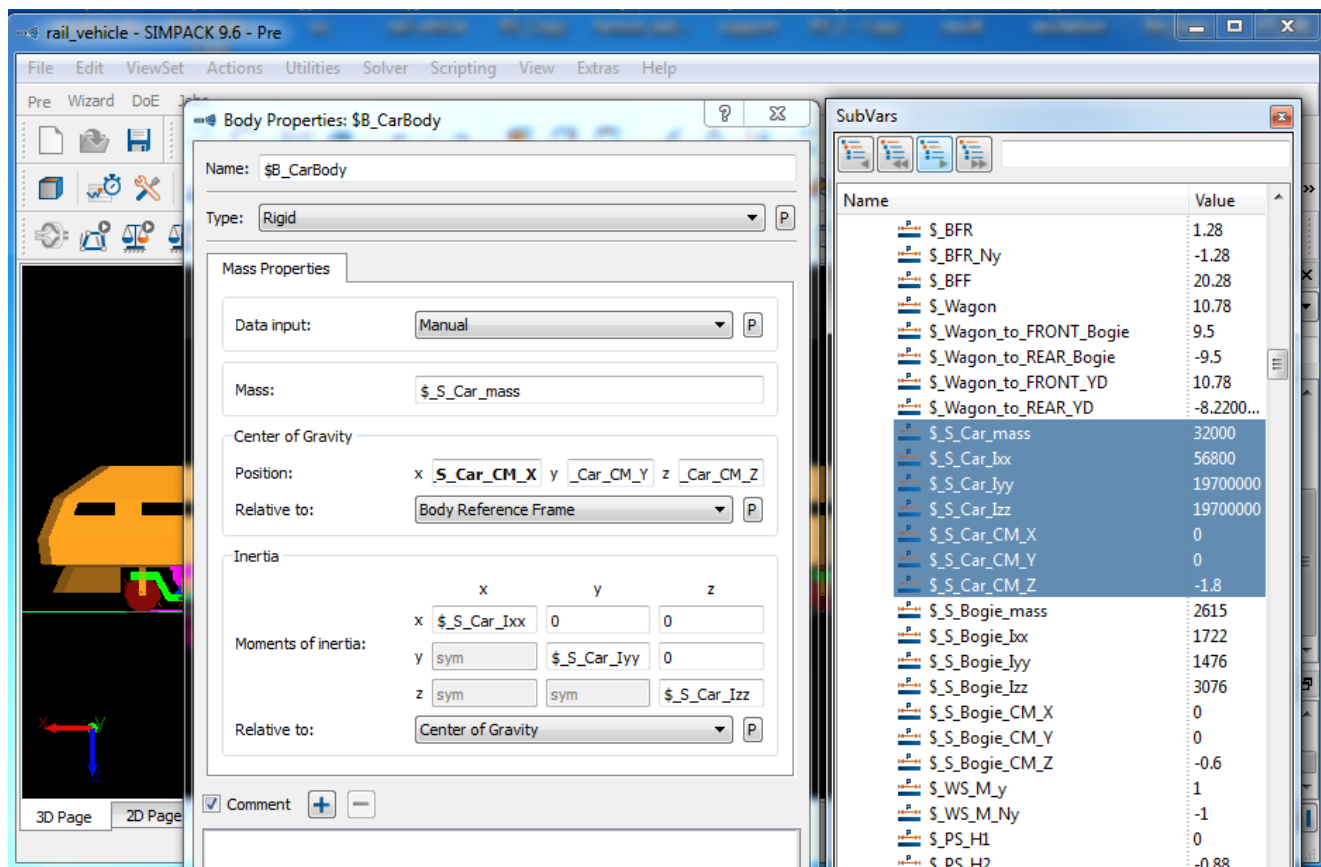

Figure 3.2: Input of rail vehicle car body parameters using SIMPACK substitution variables

b) Modeling

Using the input data the rail vehicle was modeled in SIMPACK preprocessor. The vehicle is 41 degrees of freedom (DOF) and the physical model of the vehicle is shown below.

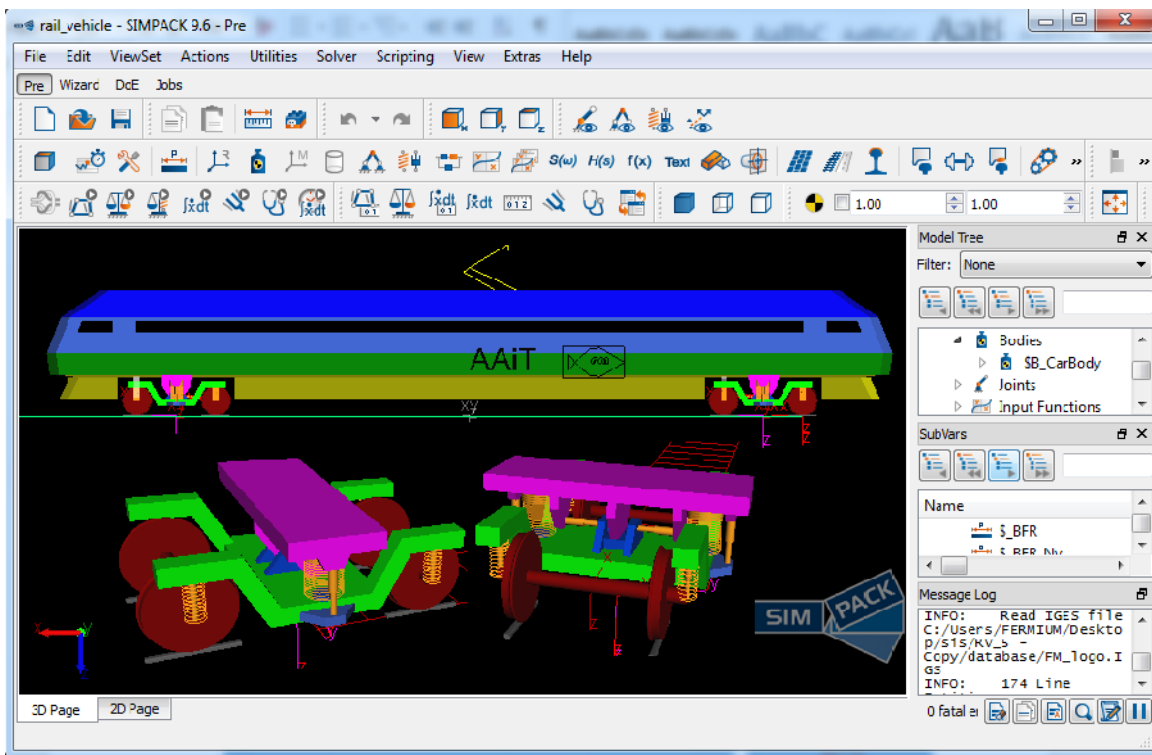

Figure 3.3: Physical model of rail vehicle using SIMPACK

Motion of bodies is described by their kinematic behavior, and dynamic behavior results from the equilibrium of applied forces and rate of change of momentum. The kinematic model of the rail vehicle using SIMPACK is given in figure 3.3. Kinematic connections between bodies or a body and a reference system are made by means of joints or constraints.

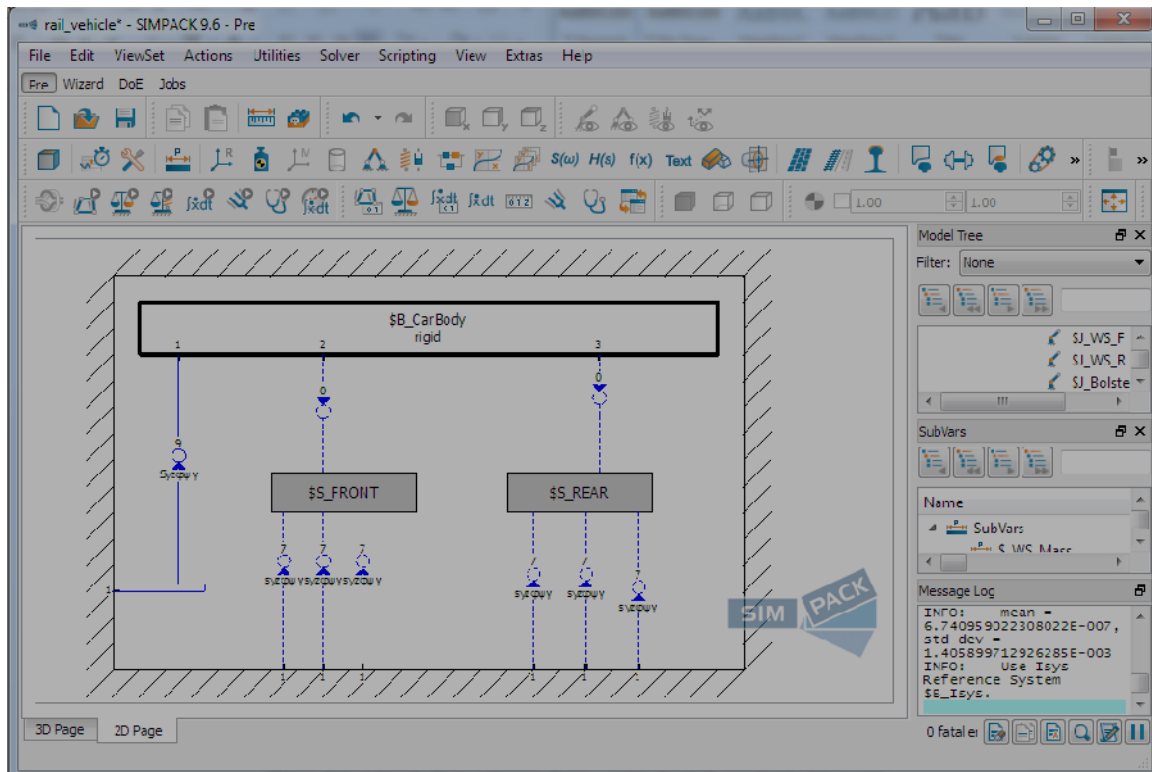

Figure 3.4: Car body kinematic connection model

Figure 3.4: is the kinematic model of the rail vehicle which shows the kinematic interaction of the car body with the inertia fixed reference frame, rear and front bogies $\$S_Rear$ and $\$S_Front$, respectively. The detail of the kinematic model of figure 3.4: is briefly described as follows:

- $\$B_Carbody$ is the rigid car body which is connected to rear and front bogie bolsters with zero degree of freedom joint (0 DOF joint)
- The joint between the car body and the inertia fixed reference system is type 9 SIMPACK joint which is a rheonomic rail track joint. This joint prescribes the movement of a rail vehicle component along a track in space. Other directions than the movement along the track are free. This type of joint is used in prescribing a constant speed or a speed profile to a car body of a rail vehicle or to a traction body for pushing or pulling a rail vehicle

- Wheel sets and bogie frames of front and rear bogies are connected to the inertia fixed reference frame using type 7 SIMPACK joint. This joint describes the movement of the main components of a rail vehicle along a track in space and it is the standard joint for wheel sets, bogie frames and car body of rail vehicles. Type 7 joint is a general rail track joint with 6 degrees of freedom which is similar to type 9 joint but the position along the track is free.

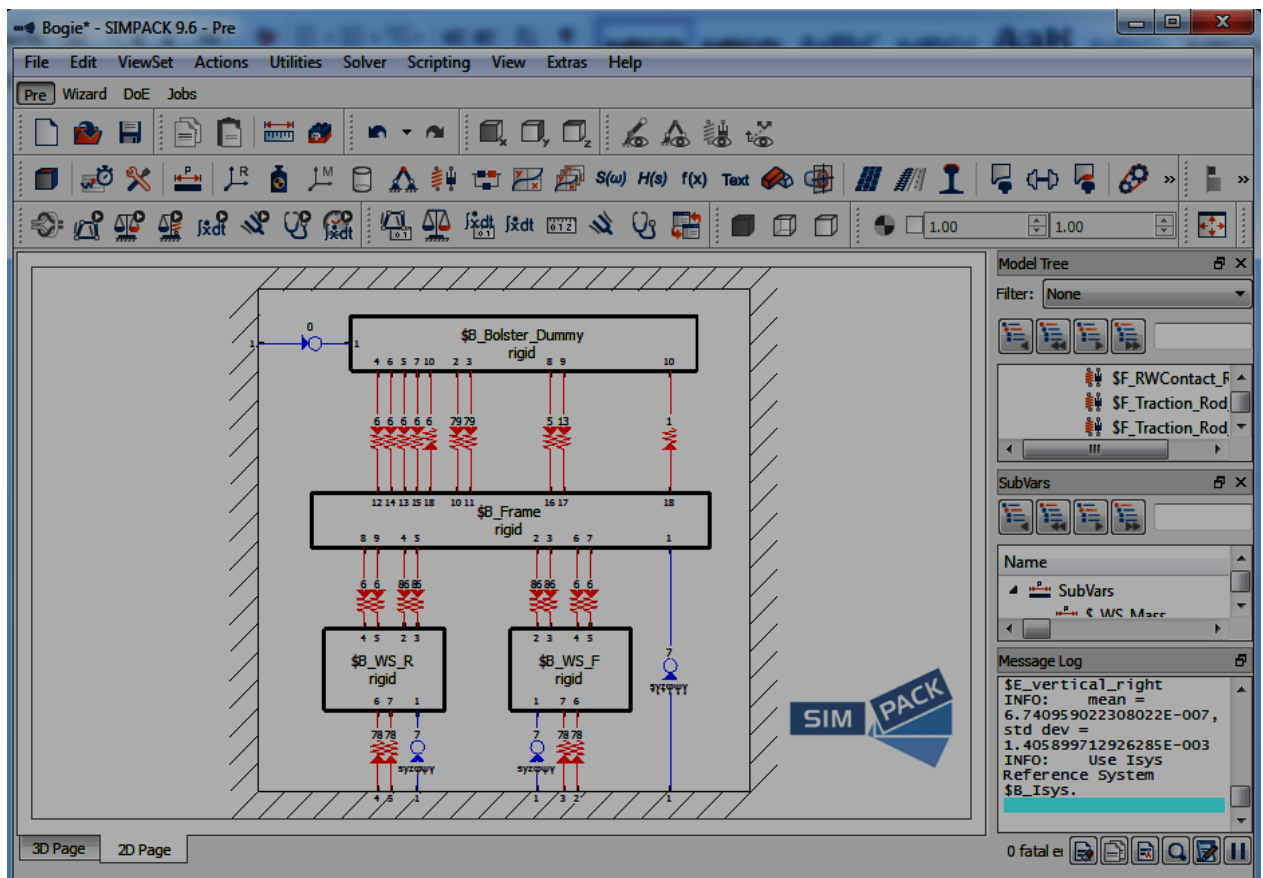

Figure 3.5: Bogie kinematic connection model

Front and rear bogies of the vehicle are made of identical motored bogies. The components of the bogie are bolster (\$B_Bolster), bogie frame (\$B_Frame), rear wheel set (\$B_WS_R) and front wheel set (\$B_WS_F). Figure 3.5 shows the kinematic connection of model of bogie components and description of the kinematic connections are as follows:

- The bolster of a bogie is connected to the car body using zero degree of freedom joint (0 DOF joint)
- Bolster of a bogie is connected to a bogie frame using force element 5 to model bump stop. This universal force element applies spring and damper forces between two markers in the three translation directions. The force laws are separately defined for each direction and can be linear, nonlinear or expressions. This type of force element is used for modeling the translational part of six-axial elasto-kinematic connections ('bushings'), simple elastic bearings, general linear and non-linear spring-damper connections including clearance.
- Secondary anti roll bar is modeled using force element 13 which connects bolster to bogie frame. This universal force element applies spring and damper torques between two markers in the three rotation directions. The torque laws are separately defined for each direction and can be linear, nonlinear or expressions. This type of force element is used for modeling the rotational (torque) directions of six-axial elastokinematic connections ('bushings'), simple elastic bearings and general linear and non-linear spring-damper connections.
- Traction rod spring is modeled by using force element type 1 which connects bolster to bogie frame. Force element type 1 is point to point linear spring element defined by length of un-stretched length, linear stiffness of spring and additional pre load.
- Force elements type 6 which connect bolster to bogie frame are models of traction rod damper, vertical and lateral secondary dampers. This force element is linear force element which connects a spring and damper in series.

The linear force element connects a spring and damper in series and is called a Maxwell Element. It has one state, which determines either the length of the damper or spring. The Maxwell element is mainly used for the modelling of hydraulic shock absorbers. The spring constant represents the flexibility in the elastomer mountings, the compressibility of the hydraulic fluid and the flexibility of the rods and the cylinder in the mechanical damper design.

- Secondary springs are modeled by using force element type 79 which connect bolster to bogie frame. This force element describes a typical coil spring (helical spring) with shear forces and bending torques coupled. The force law in the coil axis direction can be linear or non-linear. Bending about the x-axis is called 'roll', bending about the y-axis is called 'pitch' in this force element. Rotation about the z-axis is called torsion. This force element is used for modeling coil springs with large shear deformation in particular, secondary and primary suspension of rail vehicles.
- Primary dampers are modeled by using force elements type 6 that connect bogie frame to wheel set.
- Primary springs are modeled by using force element type 86 which connect bogie frame to wheel set. This universal force element applies spring and damper forces and torques between two markers in multiple axis directions, i.e. the three translations as well as the three rotations. The force laws are linear, i.e. defined by stiffness and damper constants, and separately defined for each direction. They can include a spring and a damper in parallel as well as another spring and damper, connected in series, parallel to these. This force element is used for modeling of six-axial elastokinematic connections ('bushings'), simple elastic bearings including simple elastomer behavior (Poynting-Thomson model).

Vehicle rail contact was modeled using the contact data of appendix C.3 and the physical and kinematic models are shown in figure 3.4. The applied contact theories are [7,10]:

- Contact normal force: Hertzian
- Creep force: Kalker's FASTSIM algorithm

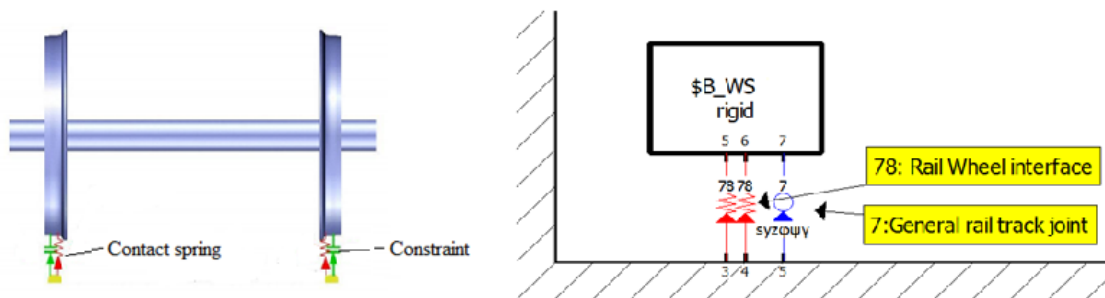

Figure 3.6: Wheel rail interaction model using SIMPACK: physical model (left) kinematic connection model (right)

Figure 3.6 shows wheel rail interaction model and it is described as follows:

- Wheel rail interaction is modeled by force element 78, rail wheel interface force element. This force element provides the contact calculation between rail and wheel and all parameters of the rail wheel contact are controlled by the rail wheel pair. This type of force element is used to model rail vehicles and similar guided vehicles.
- The joint between wheel set and the reference frame is modeled by using the general rail track joint type 7.

To assess behavior of the vehicle for broad parameter ranges and to evaluate sensitivity of the model against parameter changes the vehicle was simulated by varying one parameter at a time and the individual effect of each parameter on ride acceleration was studied. The passenger track vehicle model of figure 3.2 was used to study and analyze railway vehicle ride acceleration under a given track and speed profile.

Parametric analysis was conducted by running the vehicle on a rigid straight track of length 10Km using a constant velocity of 25m/s along the track. The rail vehicle parameters were allowed to vary from -25% to +25% of their original values [11] and the parameters are:

- Mass of car body
- Mass moment of inertias of car body (I_{xx} , I_{yy} and I_{zz})
- Primary spring stiffness values
- Secondary spring stiffness values
- Primary dampers damping coefficients
- Secondary dampers damping coefficients
- Bogie wheel base – center to center distance of wheel sets in a bogie

c) Analysis

SIMPACK solvers convert the modeling elements and model structure into a set of nonlinear ordinary differential equations (ODE). Models containing Constraints and/or algebraic states require an additional set of algebraic equations. The complete set of equations is then called differential algebraic equations (DAE). Dynamic behavior of the vehicle was calculated using time integration solver of SIMPACK on a straight track in time domain. The initial conditions for the simulation were the equilibrium position and velocity along track, $v = 25\text{m/s}$. The time integration solver determines the complete behavior of the fully nonlinear model in time domain by solving the full set of nonlinear equations of motion.

d) Post processing

The processed data can be generated in 2D plots, 3D plots, and 3D animations along with integration settings and integration statistics. Filters modify, during post processing, data signals in various ways, connect them or generate specific results from them. To find characteristic frequencies and to create a bode like plot from a time integration simulation the filter 106 spectrum is applied to the time integration simulation of the rail vehicle. To transform it from time domain into frequency domain; the filter calculates different types of spectra from an input signal by transforming it into frequency domain. The filter uses the Fast Fourier Transform (FFT) algorithm. The input signal is usually in time or distance domain, the resulting spectrum is in frequency domain.

CHAPTER 4

RESULTS AND DISCUSSIONS

4.1. Results

Vertical and lateral accelerations of the car body at the floor above front bogie center, obtained from computer simulation using SMPACK are shown in Figure 4.1. The rail vehicle was simulated using the simulation condition on a straight standard track as discussed in chapter 3.

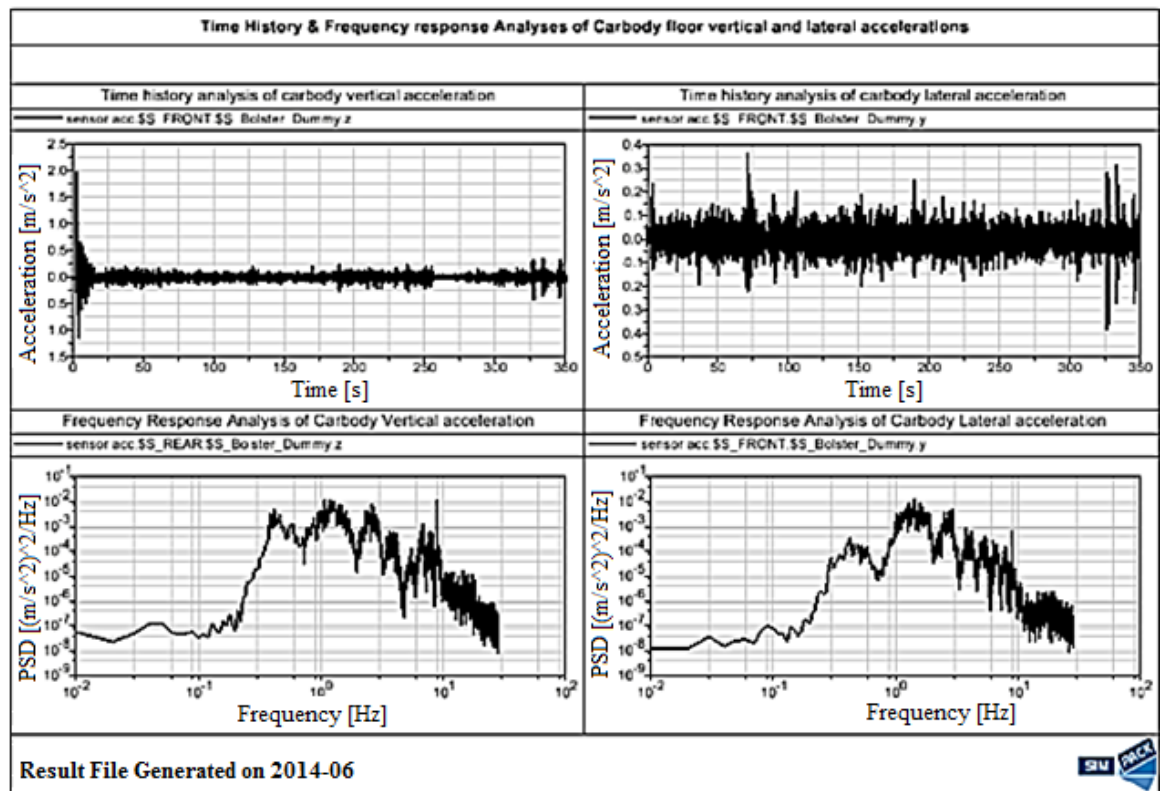

Figure 4.1: Car body vertical & lateral accelerations from SIMPACK analysis

4.1.1. Validation of simulation results

To validate the software simulation results, the simulated results were compared with results obtained from acceleration measurements through actual testing. The results from actual testing were obtained from Research Designs Standards Organization, Lucknow [11]. The rail vehicle was moved at a constant speed of 80 km/hr over straight track. The data acquisition was completed in two stages. In the first stage the record was obtained for 2Km straight specimen run down track and the record was verified covering a long run of about 25 Km in the second stage. A strain gauge accelerometer (Range: +1g & +2g; Frequency response: 25Hz; Excitation: 5V AC/DC; Sensitivity: 360 mV/V/g; Damping: silicon fluid) was placed at floor level near bogie pivot of the rail vehicle. The acceleration data was recorded in time domain with National Instruments cards (Sampling rate: 100 Samples/s, Resolution: 12 Bit) using Lab View software program and the record was converted in frequency domain using Fast Fourier Transformations (FFT).

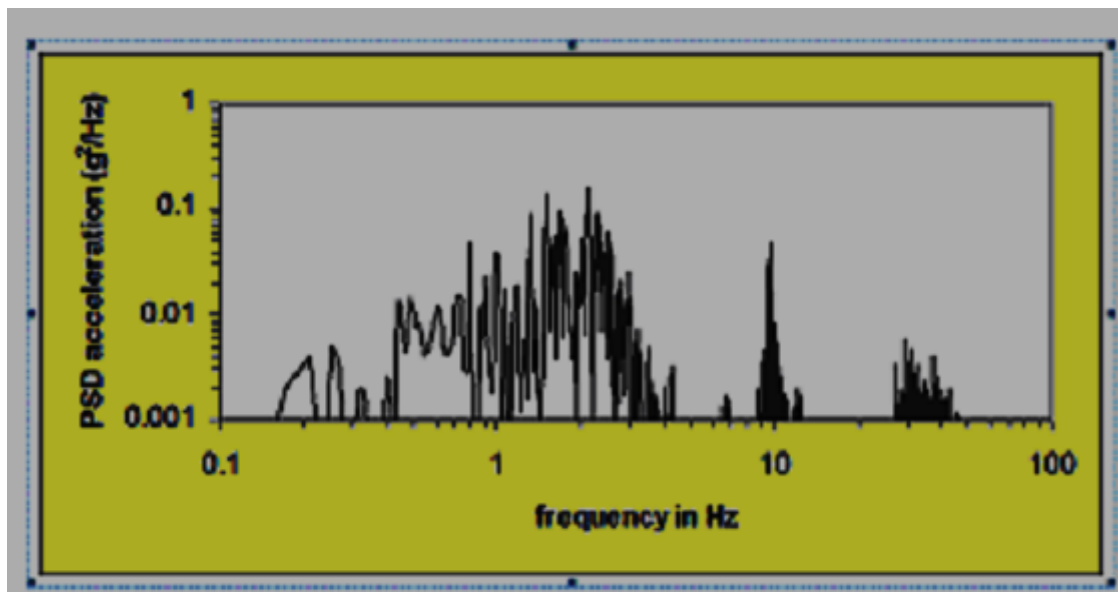

Figure 4.2: Power Spectral Density of vertical acceleration (in $(\text{m/s}^2)^2/\text{Hz}$) of car body from tests [11]

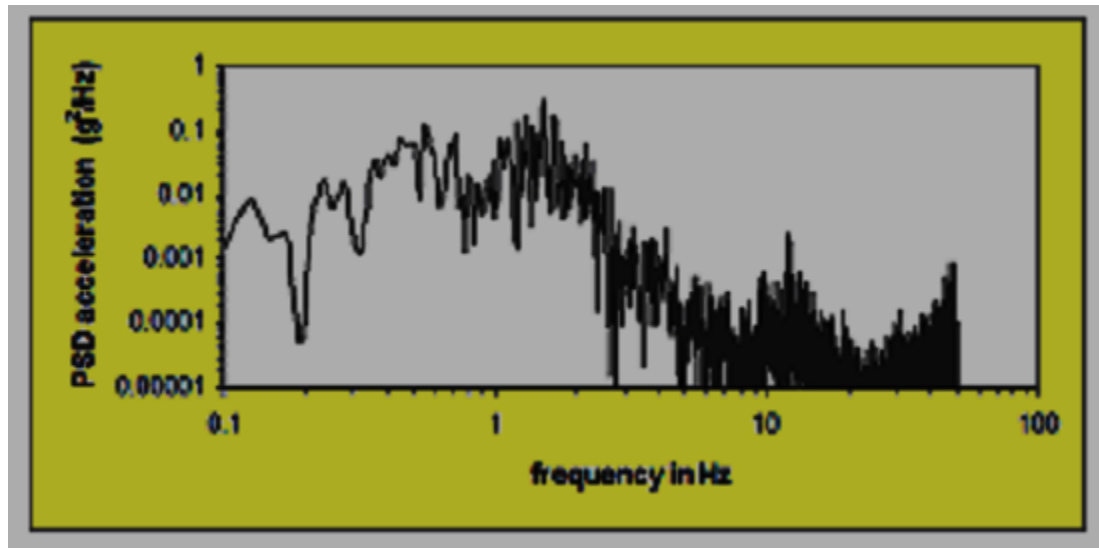

Figure 4.3: Power Spectral Density of lateral acceleration (in $(\text{m/s}^2)^2/\text{Hz}$) of car body from tests [11]

Power spectral densities of accelerations of car body obtained through actual testing in vertical and lateral directions are shown in Figures 4.2 and 4.3 respectively. Software simulation and experimental results compare reasonably well except that the peak values are slightly different and obtained at slight different frequencies due to some factors that can lead to variation of simulation and experimental results. The factors which influence software simulation and experimental test results are as follows:

- The car body in modeling was assumed as a rigid body discounting the influence of flexible structure
- Braking system, and other systems were not incorporated in modeling and simulation
- The mass of the track was not considered to any of assigned degree of freedom
- In actual testing the sensor for acceleration measurements was placed at floor level of bogie pivot but in simulations the acceleration was determined at car body floor just above a bogie center

- The effect of wind drag forces were not considered in the present analysis. In actual the wind forces from longitudinal and lateral directions significantly affect the dynamics of rail vehicle system
- It is also possible that there may be a time gap between random inputs measurements of track and acceleration measurements of vehicle as a result of which the track profile may have been changed
- The track irregularities considered were not the same in both actual and simulation
- In practice, defects may occur with the passage of time such as wheel flats, defects in the bearings of the wheel axle sets and other moving parts resulting in extra force inputs

4.2. Discussions

The aim of this thesis is to study how the vertical and lateral accelerations of the rail vehicle behave when a rail vehicle parameter is increased. The effect of each parameter on ride behavior was analyzed by varying original values of vehicle parameters from -25% to +25% [3, 11]. The detail of the parametric analysis results along with their variation ranges are shown in appendix D. The analysis was conducted by taking three points for each parameter i.e. -25%, original value and +25%. But, the discussion focuses on the critical frequency range of human vibration sensitivity, i.e. 0.5-2Hz and 4-10Hz for horizontal and vertical car body accelerations respectively, as the other frequencies do not cause human discomfort due to vibration. Therefore, the ride accelerations of the rail vehicle are discussed only on critical frequency ranges of human body ride vibration sensitivity and the discussion of the influence of vehicle parameters on car body lateral and vertical accelerations for the frequency range of interest are presented below.

4.2.1. Influence of car body parameters on vehicle vertical and lateral accelerations

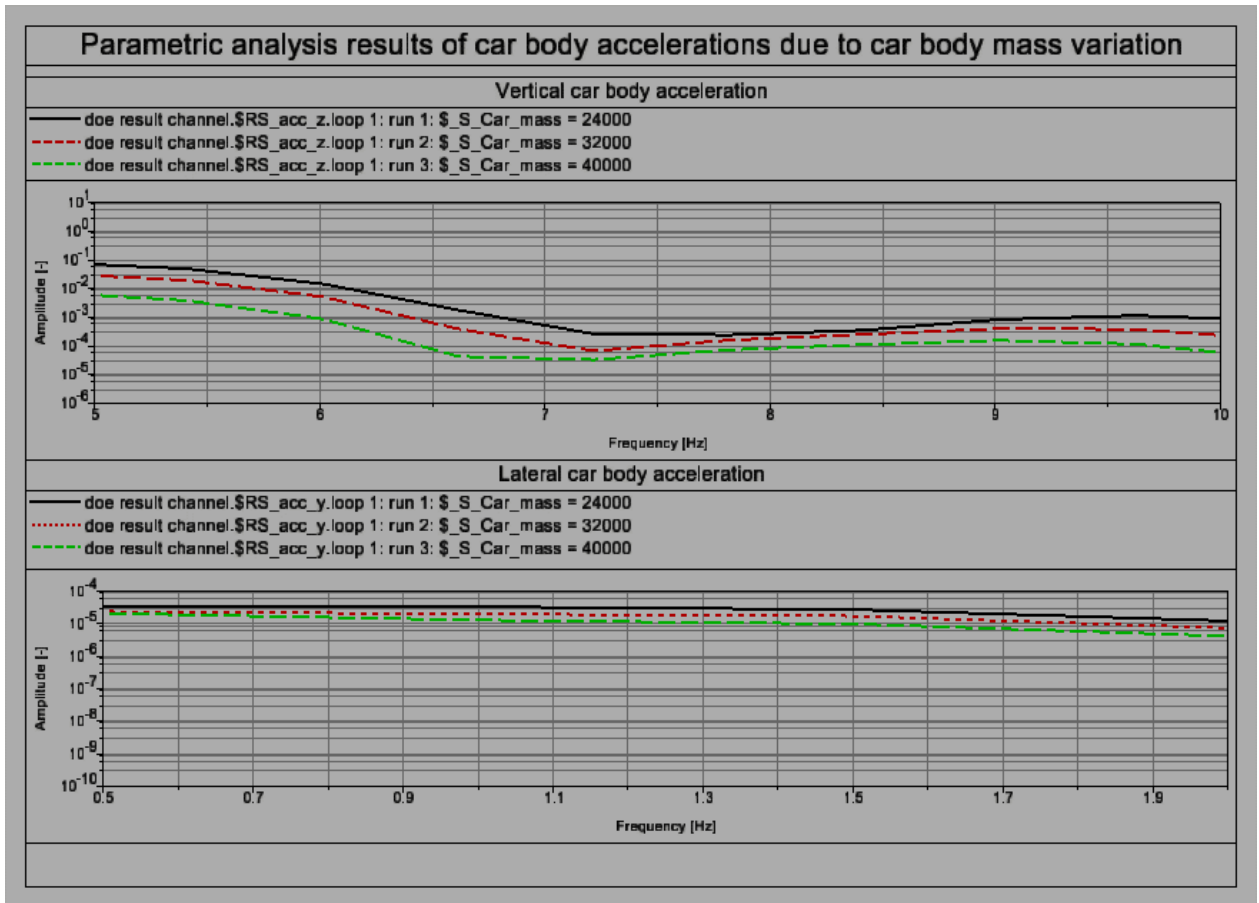

Figure 4.4: Parametric analysis results of car body mass

From the analysis result, car body mass affects both vertical and lateral car body acceleration responses. Increased car body mass results in reduced magnitudes of vertical and lateral car body accelerations in the critical frequency zones of interest.

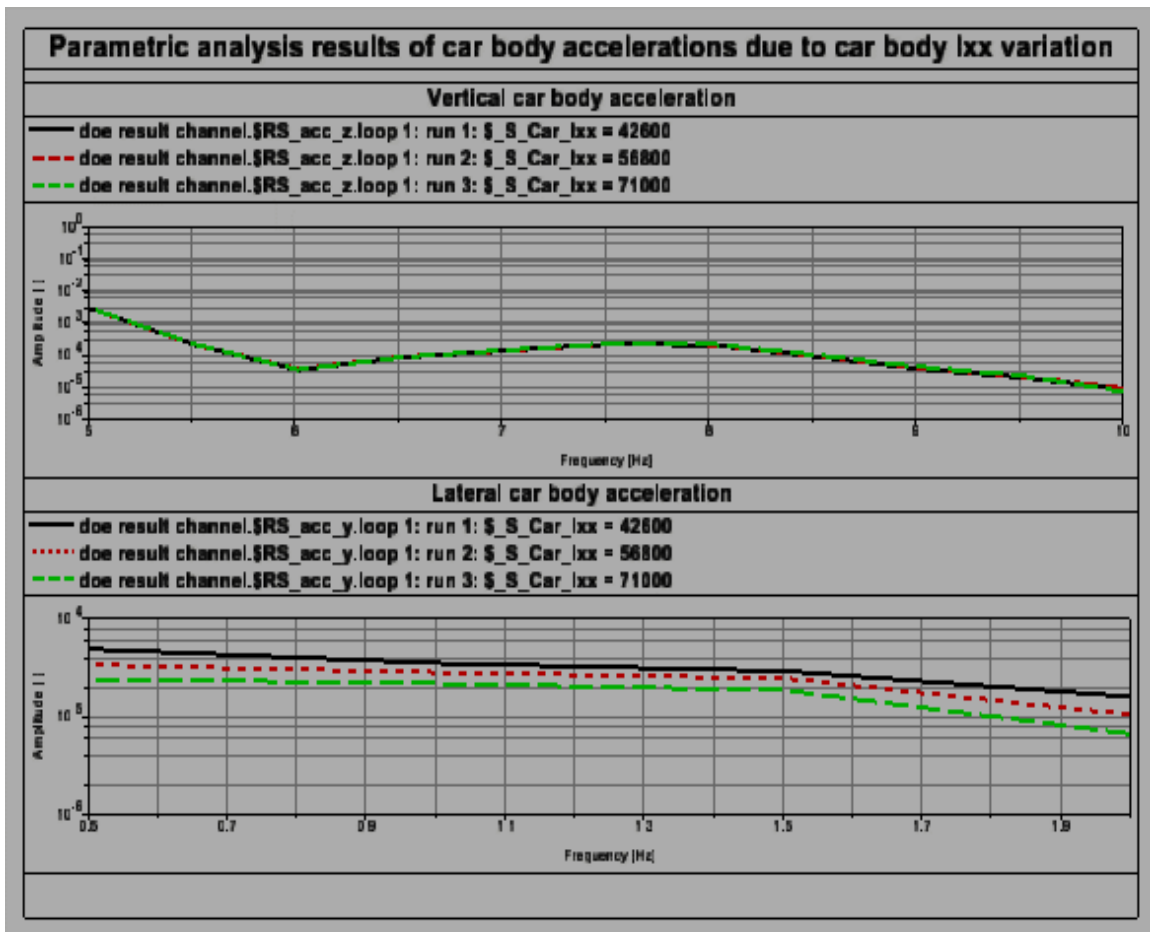

Figure 4.5: Parametric analysis results of car body roll mass moment of inertia, I_{xx}

From the analysis results roll mass moment of inertia has negligible effect on vertical acceleration values, but it affects the lateral acceleration values. The values of lateral acceleration at the frequency range of interest are reduced with increase in roll mass moment of inertia.

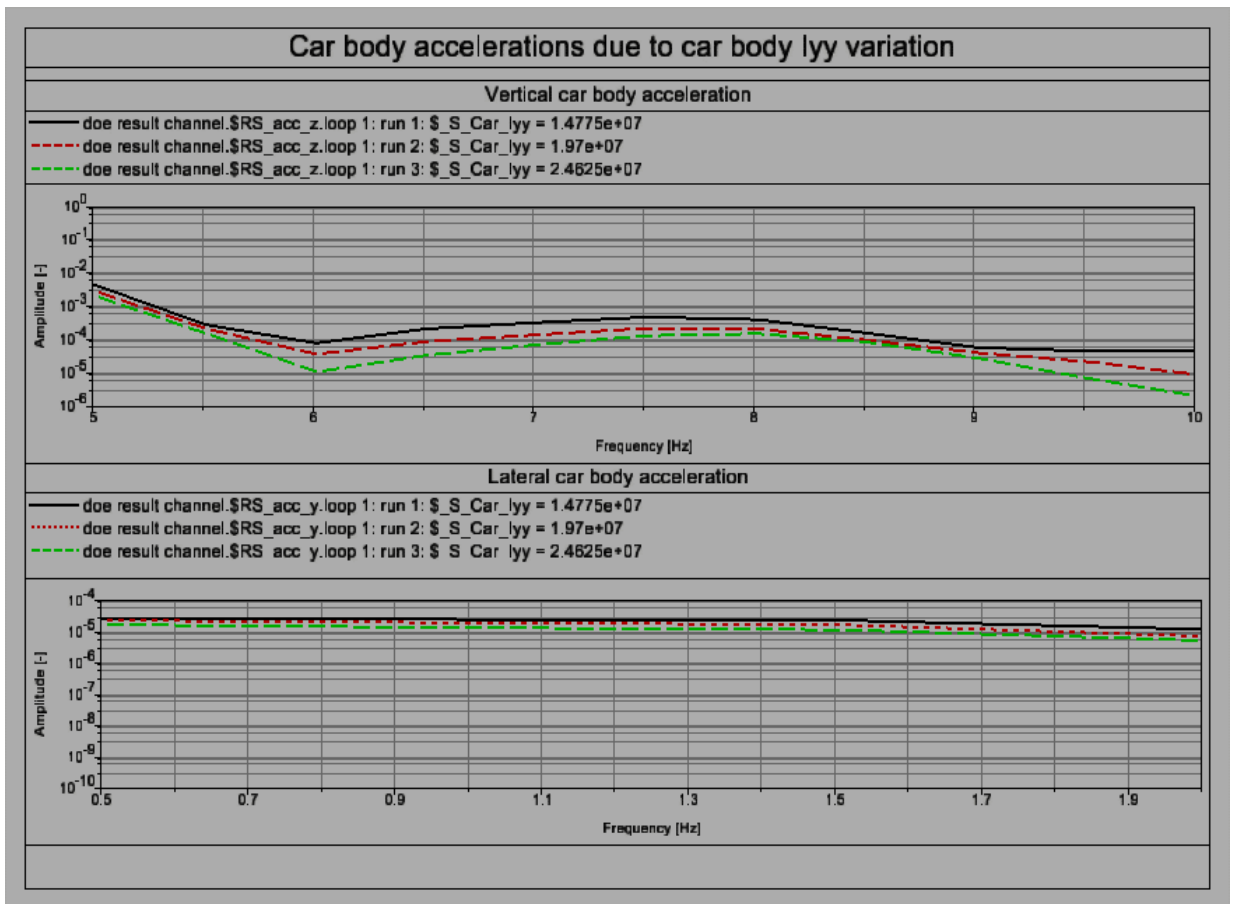

Figure 4.6: Parametric analysis results of car body pitch mass moment of inertia, I_{yy}

From the parametric analysis result of figure 4.6 it is shown that pitch mass moment of inertia affects both vertical and lateral accelerations. But, increased pitch mass moment of inertia from existing value results in reduced magnitudes of lateral and vertical car body accelerations in the frequency regions of interest. However, the reduction is larger in the vertical than the lateral one.

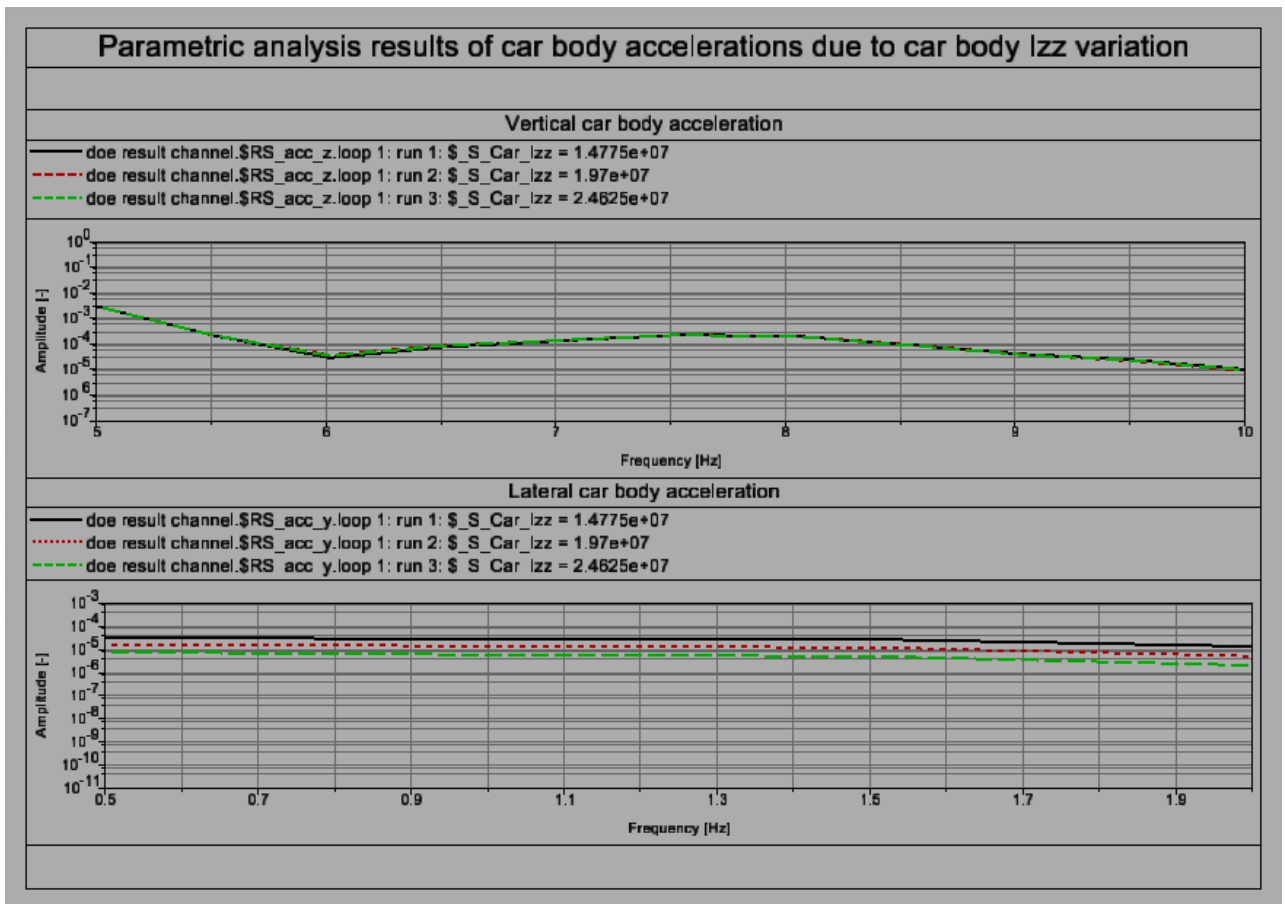

Figure 4.7: Parametric analysis results of car body yaw mass moment of inertia, I_{zz}

Yaw mass moment of inertia has negligible effect on vertical values of car body acceleration in the frequency range of interest, but it significantly affects the lateral car body acceleration values in such a way that increased yaw mass moment of inertia from existing value resulted in reduced magnitudes of lateral acceleration in the frequency region of interest.

4.2.2. Influence of secondary suspension parameters on vehicle vertical and lateral accelerations

Secondary suspension parameters varied in the analysis were vertical and lateral values of secondary springs and dampers, and the influence of each parameter is shown below.

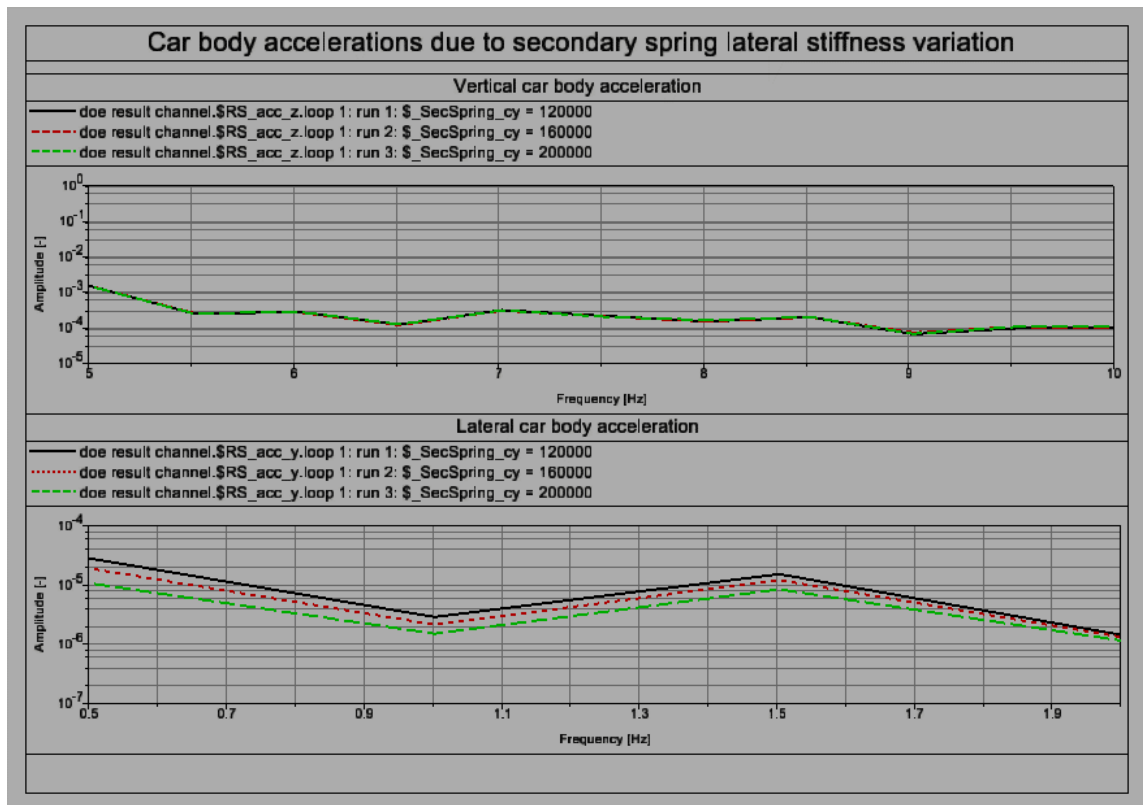

Figure 4.8: Parametric analysis results of secondary spring lateral stiffness variation

From the parametric analysis result, increased secondary suspension spring lateral stiffness resulted in decreased amplitudes of lateral car body acceleration in the frequency range of interest. But increased secondary suspension lateral stiffness has no effect on vertical acceleration in the frequency range of interest.

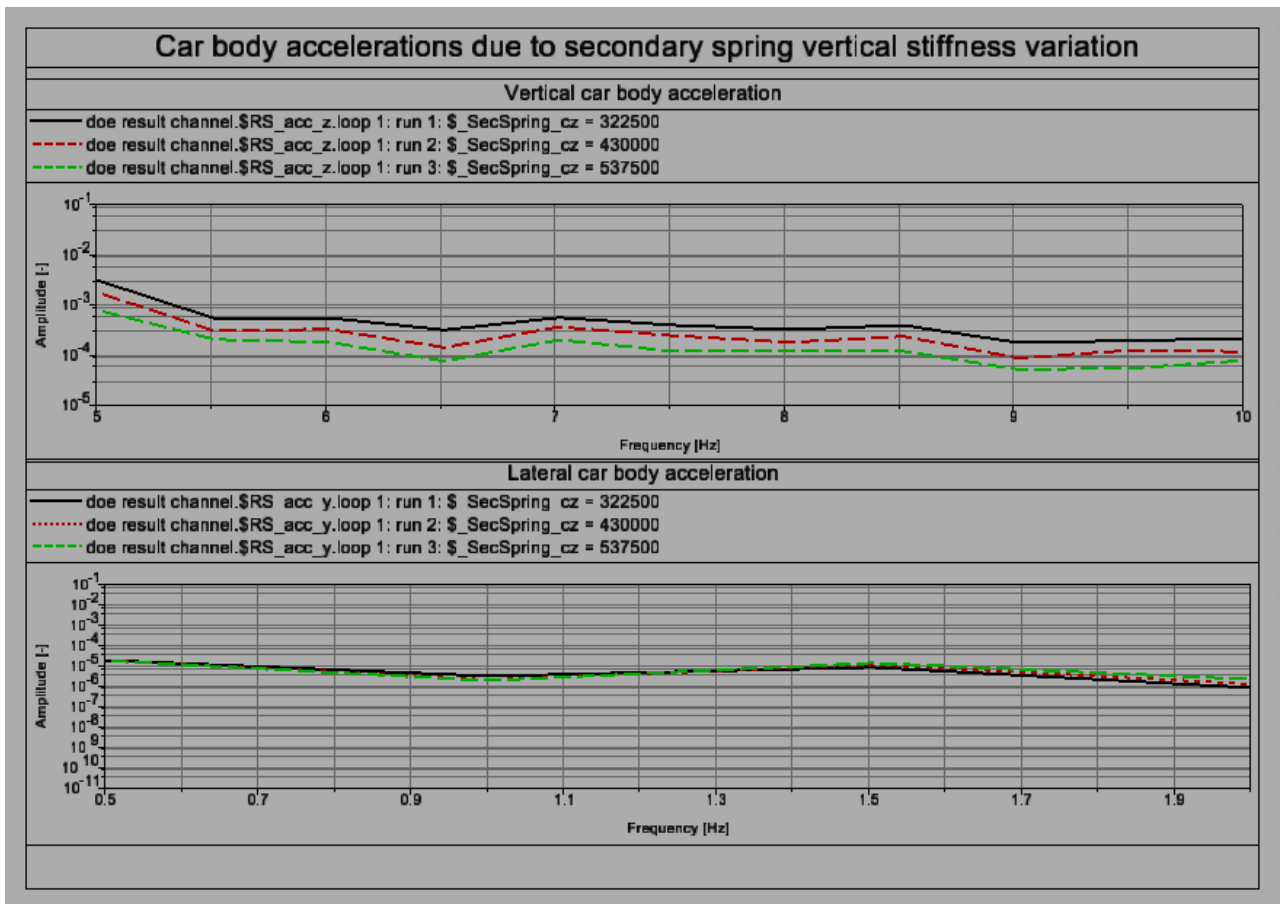

Figure 4.9: Parametric analysis results of secondary spring vertical stiffness variation

From the parametric analysis result, increased secondary suspension spring vertical stiffness resulted in decreased amplitudes of vertical car body acceleration in the frequency range of interest, so higher values from the existing values are preferred with respect to vertical acceleration as the acceleration values are reduced in the frequency range of interest. But increased secondary suspension spring vertical stiffness resulted in negligible change in lateral acceleration, so secondary suspension vertical stiffness has no effect on lateral acceleration in the frequency range of interest.

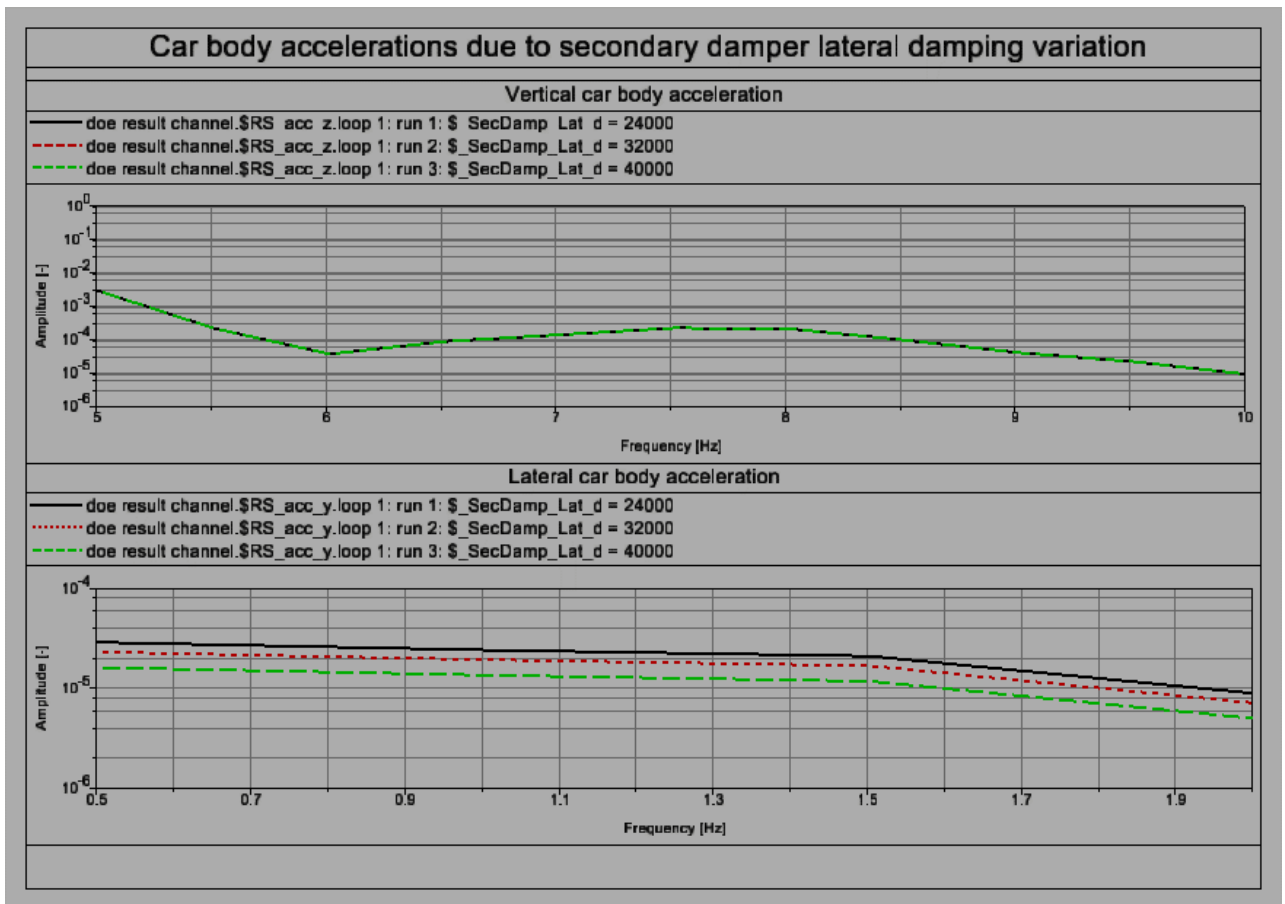

Figure 4.10: Parametric analysis results of secondary damper lateral damping variation

From the parametric analysis result, increased secondary suspension lateral damping resulted in decreased amplitudes of lateral car body acceleration in the frequency range of interest, so higher secondary suspension lateral damping coefficient values from the existing value are preferred with respect to lateral acceleration as the acceleration values are significantly reduced in the frequency region of interest. But increased secondary suspension lateral damping does not change the amplitudes of vertical car body acceleration in the frequency range of interest, so secondary suspension lateral damping coefficient has negligible effect on vertical acceleration values.

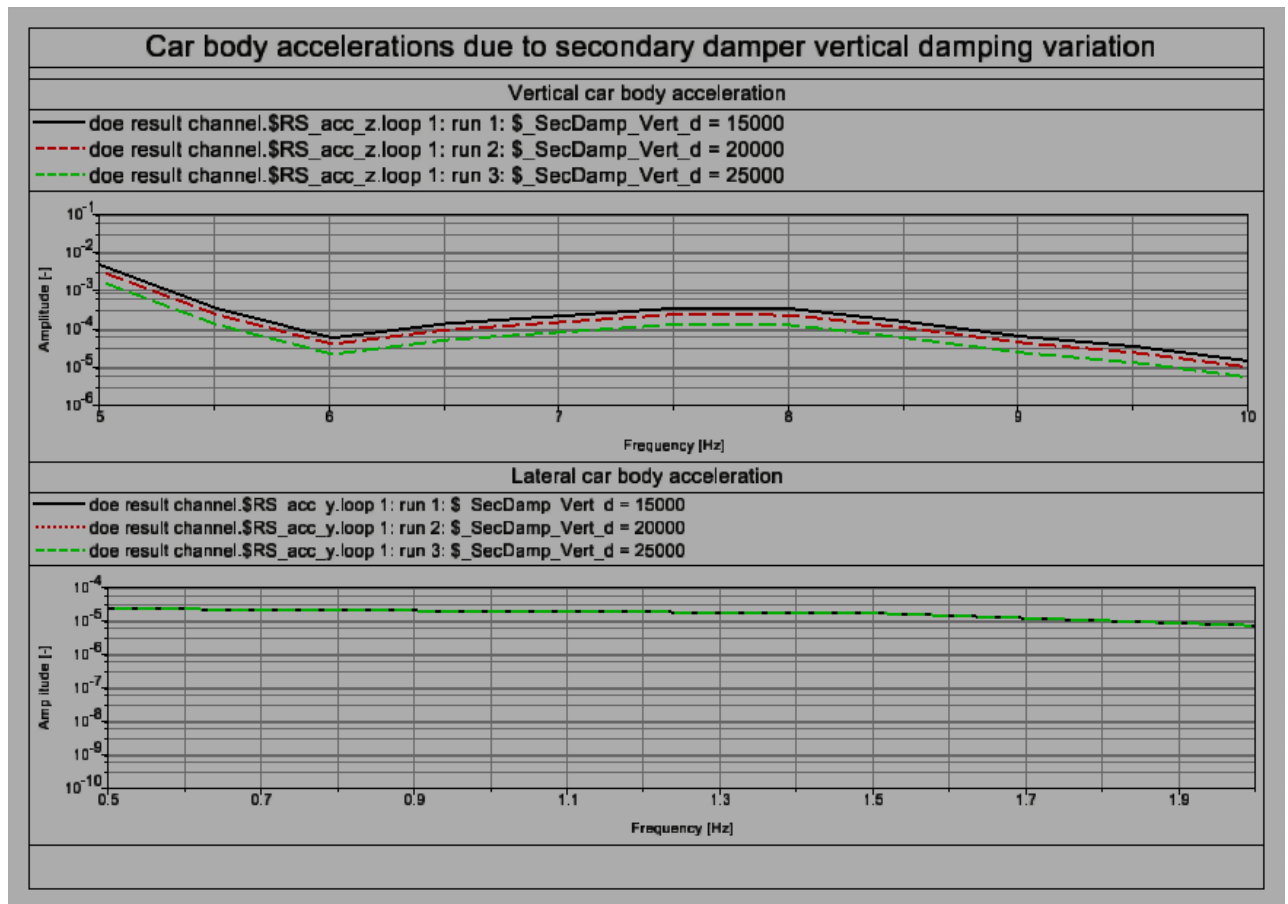

Figure 4.11: Parametric analysis results of secondary damper vertical damping variation

From the parametric analysis result, increased secondary suspension vertical damping resulted in decreased amplitudes of vertical car body acceleration in the frequency range of interest, so higher secondary suspension vertical damping coefficient values from the existing value are preferred with respect to vertical acceleration as the acceleration values are significantly reduced in the frequency region of interest. But increased secondary suspension vertical damping does not change the amplitudes of lateral car body acceleration in the frequency range of interest, so secondary suspension vertical damping coefficient has negligible effect on lateral acceleration values.

4.2.3. Influence of primary suspension parameters on vehicle vertical and lateral accelerations

Primary suspension parameters varied in the analysis were vertical and lateral values of primary springs and dampers, and the influence of each parameter is shown below.

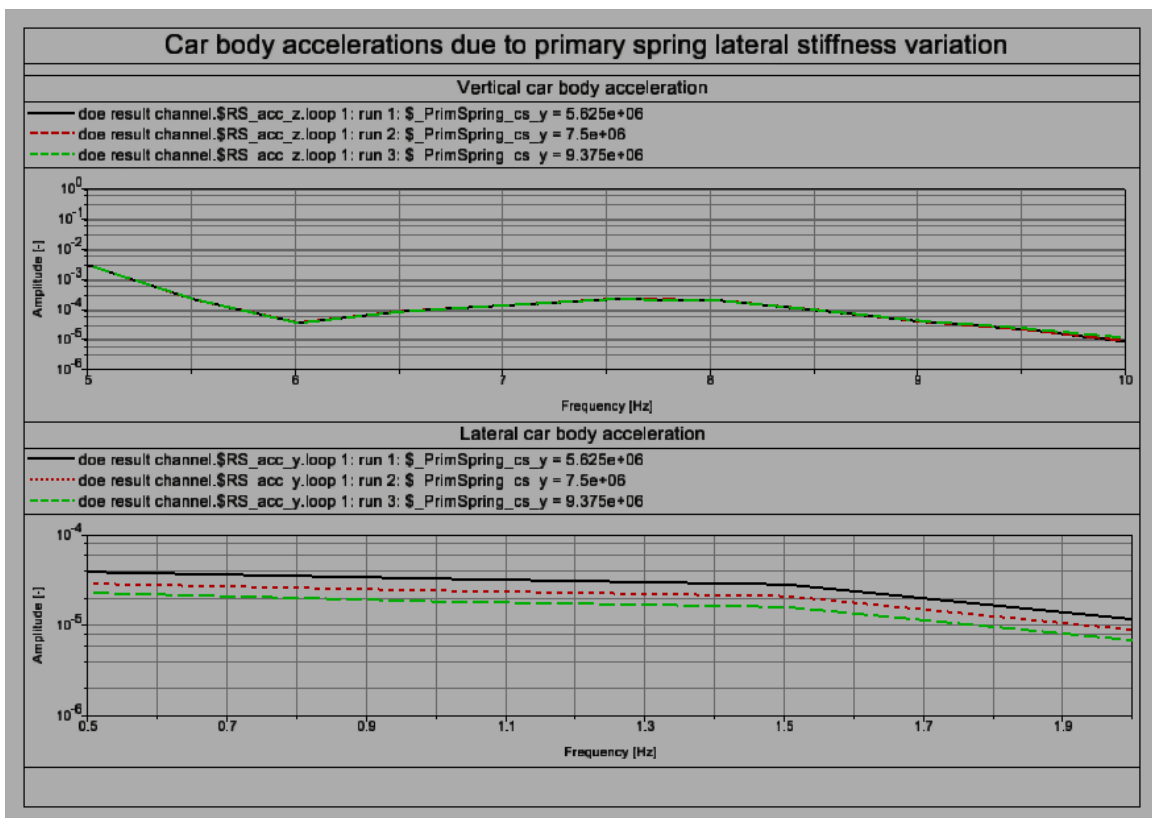

Figure 4.12: Parametric analysis results of primary spring lateral stiffness variation

From the parametric analysis result, increased primary suspension spring lateral stiffness resulted in decreased amplitudes of lateral car body acceleration in the frequency range of interest. But increased primary suspension lateral stiffness has no effect on vertical acceleration in the frequency range of interest.

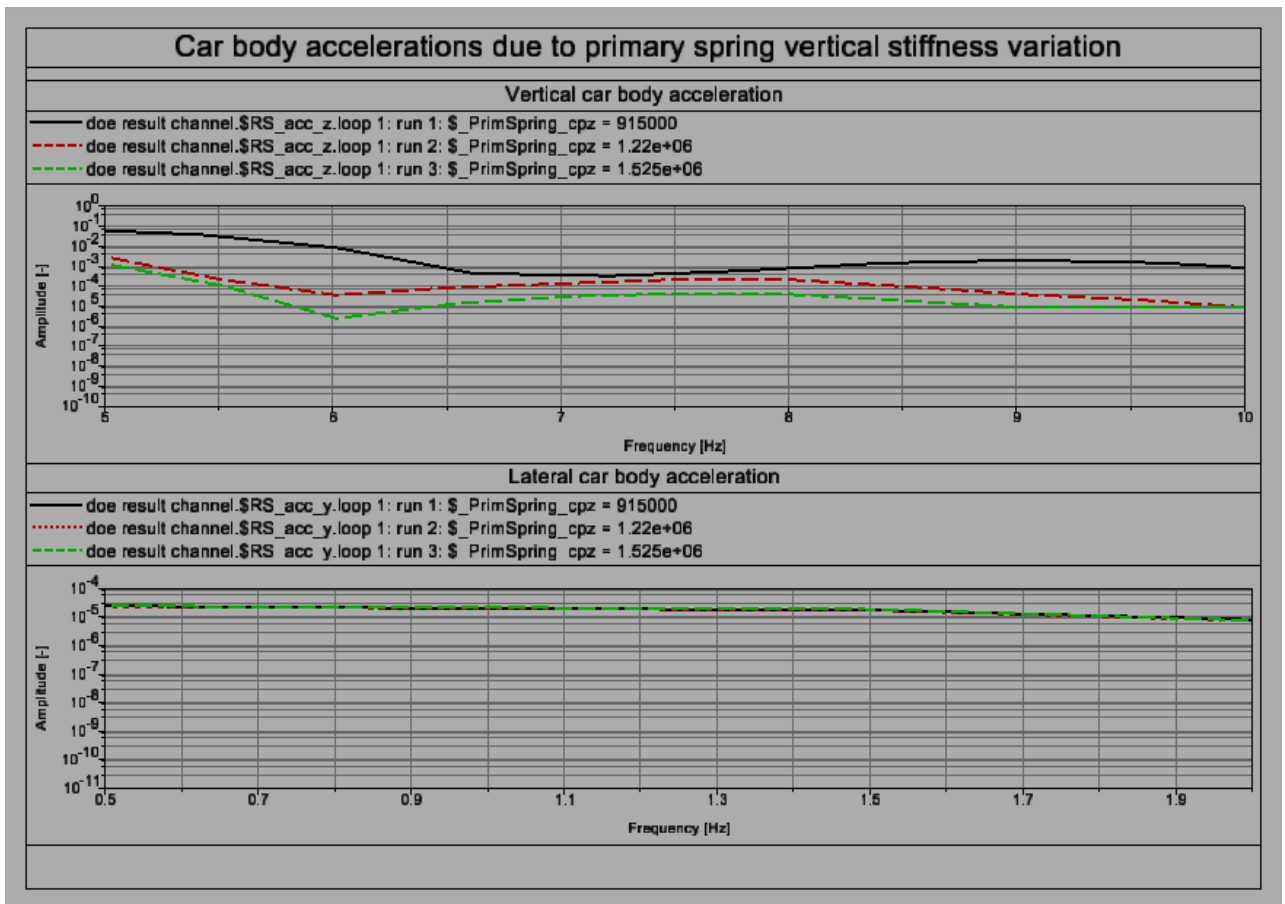

Figure 4.13: Parametric analysis results of primary spring vertical stiffness variation

From the parametric analysis result, increased primary suspension spring vertical stiffness resulted in decreased amplitudes of vertical car body acceleration in the frequency range of interest, so higher values from the existing values are preferred with respect to vertical acceleration as the acceleration values are reduced in the frequency range of interest. But increased primary suspension spring vertical stiffness resulted in negligible change in lateral acceleration, so secondary suspension vertical stiffness has no effect on lateral acceleration in the frequency range of interest.

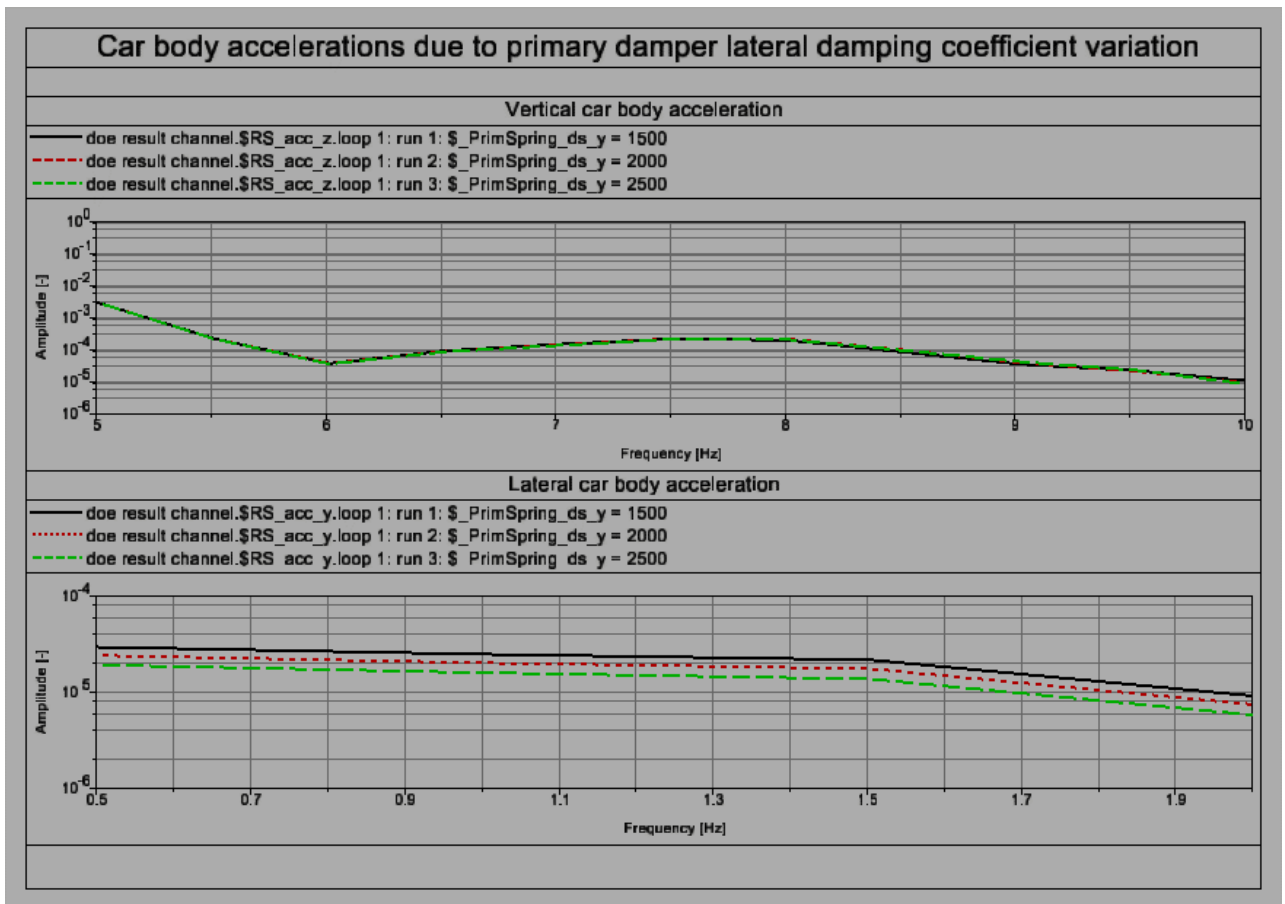

Figure 4.14: Parametric analysis results of primary damper lateral damping variation

From the parametric analysis result, increased primary suspension lateral damping resulted in decreased amplitudes of lateral car body acceleration in the frequency range of interest. But increased primary suspension lateral damping does not change the amplitudes of vertical car body acceleration in the frequency range of interest, so primary suspension lateral damping coefficient has negligible effect on vertical acceleration values.

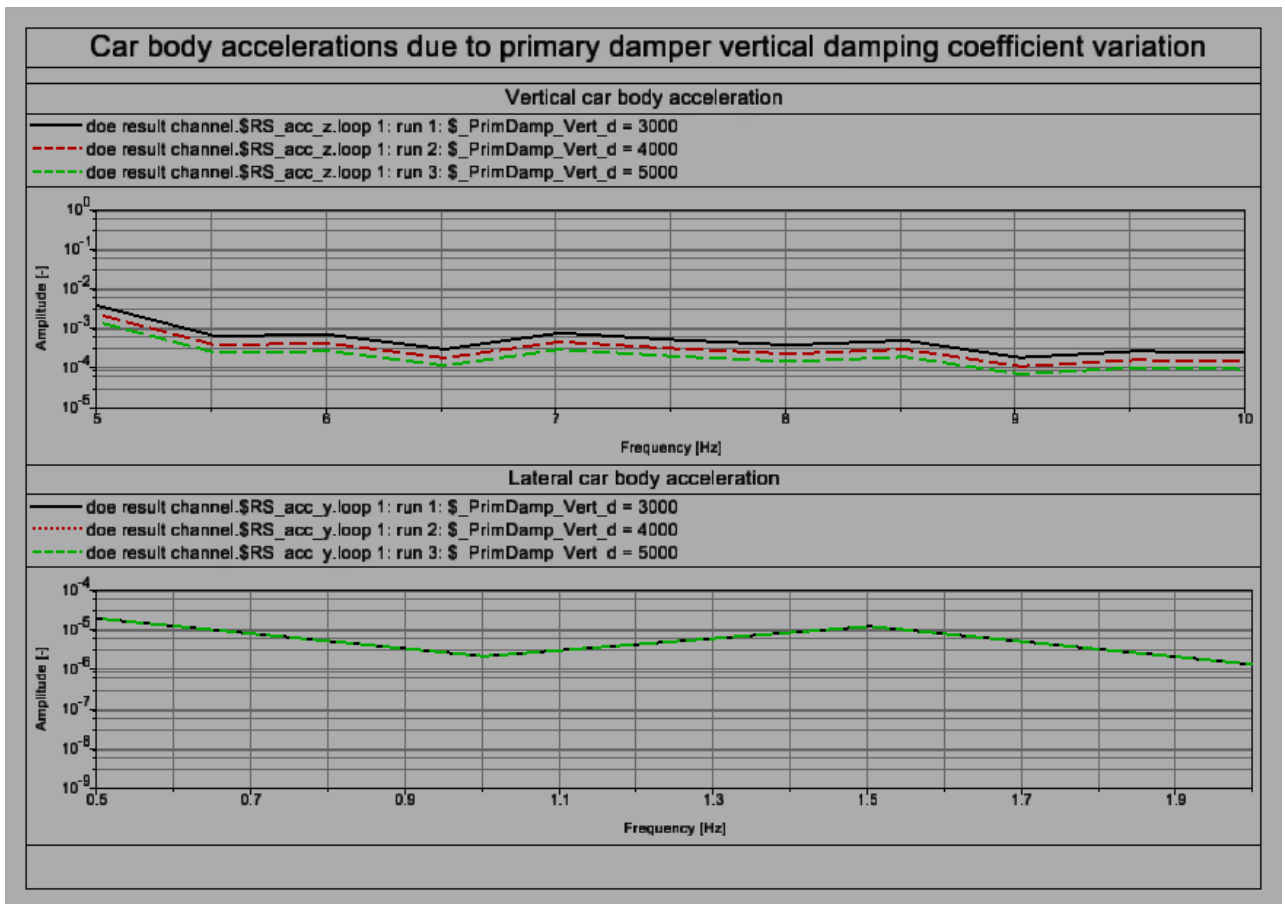

Figure 4.15: Parametric analysis results of primary damper vertical damping variation

From the parametric analysis result, increased primary suspension vertical damping resulted in decreased amplitudes of vertical car body acceleration in the frequency range of interest. But increased primary suspension vertical damping does not change the amplitudes of lateral car body acceleration in the frequency range of interest, so primary suspension vertical damping coefficient has negligible effect on lateral acceleration values.

4.2.4. Influence of bogie frame wheel base on vehicle vertical and lateral accelerations

Bogie parameter varied in the analysis was bogie frame wheel base, and the influence of the parameter is shown below.

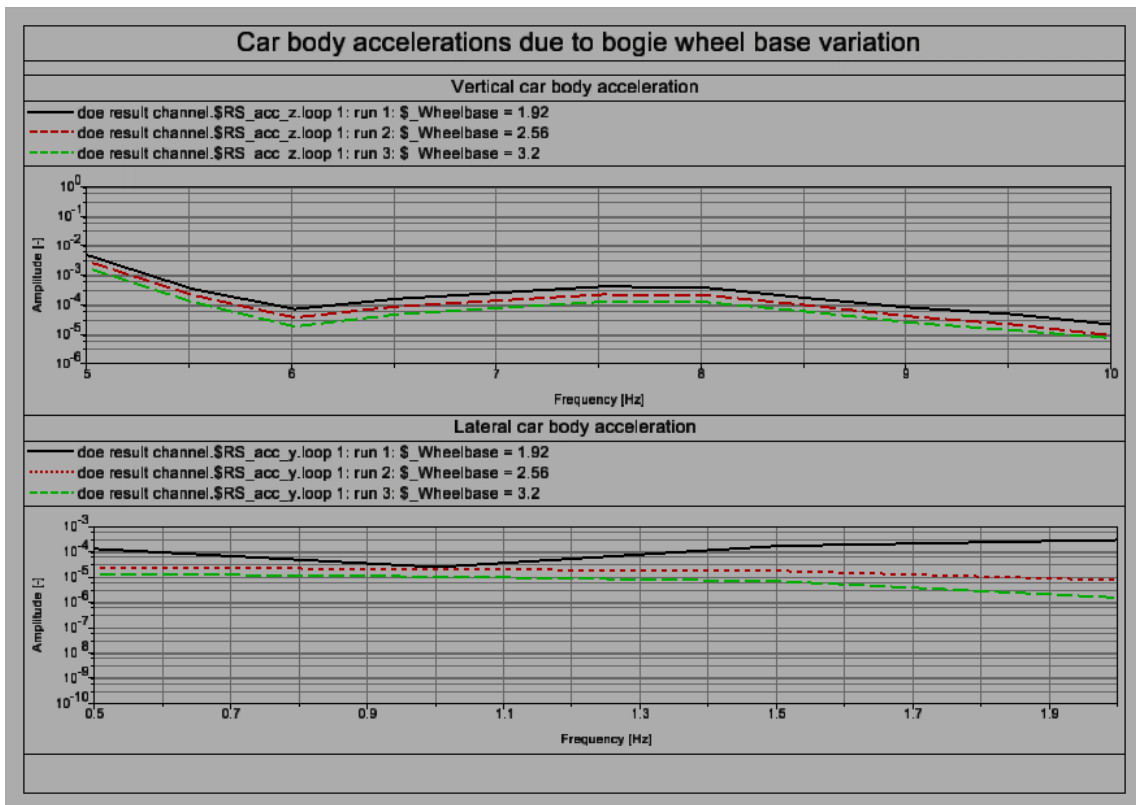

Figure 4.16: Parametric analysis results of bogie wheel base

From the parametric analysis result, increased bogie wheel base resulted in decreased amplitudes of vertical and lateral car body accelerations in the frequency range of interest, so higher wheel base from the existing value is preferred with respect to vertical and lateral accelerations as the acceleration values are reduced in the frequency region of interest.

CHAPTER 5

CONCLUSIONS, RECOMMENDATIONS AND FUTURE WORKS

5.1. Conclusions

Parametric study was conducted on a passenger rail vehicle using SIMPACK multibody simulation tool to study the effect of rail vehicle parameters on vertical and lateral ride of the vehicle with in the frequency range of human ride sensitivity to vibration, i.e. 0.5-2Hz and 5-10Hz for lateral and vertical ride respectively. Ride comfort implies that the vehicle is being assessed according to the effect of the mechanical vibrations on the human body and is affected by amplitude and frequency of vibration among others [10]. On a given frequency of vibration, reduced amplitude of vibration results in improved ride comfort [4]; therefore, the following conclusions are made from the simulation results:

- Increasing car body mass reduces magnitude of vertical & lateral accelerations; therefore, increasing car body mass in the critical frequency range improves vertical and lateral ride comforts.
- Increasing car body roll mass moment of inertia, car body yaw mass moment of inertia, car body pitch mass moment of inertia, secondary suspension lateral stiffness, secondary suspension lateral damping, primary suspension lateral stiffness, primary suspension lateral damping and wheel base resulted in improved lateral ride comfort as it reduces magnitude of lateral accelerations.
- Increasing car body pitch mass moment of inertia, secondary suspension vertical stiffness, secondary suspension vertical damping, primary suspension vertical stiffness, primary suspension vertical damping and wheel base resulted in improved vertical ride comfort as it reduces magnitude of vertical accelerations.

5.2. Recommendations

The present parametric study analyzes the single performance indices of the railway vehicle i.e. ride comfort and does not give any information about other performance indices such as lateral stability, curve negotiation ability, wear etc. The change in the existing value of a particular parameter studied in this work may improve ride comfort but it may deteriorate other performance indices; therefore, increment in car body mass, car body roll mass moment of inertia, car body yaw mass moment of inertia, car body pitch mass moment of inertia, secondary suspension lateral stiffness, secondary suspension lateral damping, primary suspension lateral stiffness, primary suspension lateral damping and wheel base is recommended to improve lateral ride comfort as investigated in this analysis provided that the increment does not affect or resulted in improved or with in the permissible values of the other performance indices. Similarly, increment in car body mass, car body pitch mass moment of inertia, secondary suspension vertical stiffness, secondary suspension vertical damping, primary suspension vertical stiffness, primary suspension vertical damping and wheel base is recommended for vertical ride comfort.

5.3. Future works

Considering the work done the following works can be proposed as future work directions.

- The rail vehicle model used in the simulation study comprises a rigid car body. However; in order to get more accurate simulation results using more advanced vehicle model with flexible car body instead of rigid body can be another point of interest.
- The present parametric study analyzed the single ride performance index of the railway vehicle i.e. ride behavior with respect to ride comfort and did not give any information about other performance indices such as lateral stability, curve negotiation ability, wear etc. The change in value of a particular parameter studied in this work may improve ride behavior with respect to ride comfort but this may deteriorate other performance indices; therefore, optimization of rail vehicle parameters is an engineering problem which needs to be solved.
- Track parameters such as flexibility, mass, geometry etc. are not considered in the current study but they do influence rail vehicle dynamics; therefore, the effect of track parameters on rail vehicle dynamic behavior is another engineering problem which needs to be studied.
- The effect of wind on ride behavior is not considered in the current study but it does influence rail vehicle dynamics; therefore, the effect of wind on rail vehicle dynamic behavior is another engineering problem which needs to be studied.

REFERENCES

- [1] Ajmi Houidi, Lotfi Romdhane, Mohamed Nejlaouia and Zouhaier Affi: Analytical modeling of rail vehicle safety and comfort in short radius curved tracks, journal of C.R. Mecanique 337 (2009) 303–311.
- [2] Ali Erdem Atalay and Semih Sezer: Dynamic modeling and fuzzy logic control of vibrations of a railway vehicle for different track irregularities, journal of Simulation Modelling Practice and Theory 19 (2011) 1873–1894.
- [3] Anneli Orvnas: Methods for reducing vertical car body vibrations of a rail vehicle, (university press, KTH engineering sciences, department of aeronautical and vehicle engineering, division of rail vehicles, SE-100 44, Stockholm, Sweden 2010, publication 1002, ISBN 978-91-7415-631-7).
- [4] Z. MILIC: Some aspects of the investigation of random vibration influence on ride comfort, journal of sound and vibration 253(1) (2012), 109–129.
- [5] Dao Gong, Wenjing Sun, Jinsong Zhou and Xiaobo Xie: Analysis on the Vertical Coupled Vibration between Bogies and Metro Car Body, journal of Procedia Engineering 16 (2011), 825 – 831.
- [6] Egidio Di Gialleonardo, Francesco Braghin and Stefano Bruni: The influence of track modelling options on the simulation of rail vehicle dynamics, Journal of Sound and Vibration 331 (2012) 4246–4258.
- [7] Enrico Meli, Stefano Falomi and Monica Malvezzi: Multibody modeling of railway vehicles, Innovative algorithms for the detection of wheel–rail contact points, journal of wear 271 (2011) 453–461.

-
- [8] H. Sayyaadi, and N. Shokouhi: Improvement of Passengers Ride Comfort in Rail Vehicles Equipped with Air Springs, journal of World Academy of Science, Engineering and Technology 53 (2009).
- [9] Karim H. Ali Abood & Prof. R. A. Khan: Railway Carriage Model to Study the Influence of Vertical Secondary Stiffness on Ride Comfort of Railway Car body Running on Curved Tracks, journal of Modern Applied Science, Vol. 5, No. 2; April 2011.
- [10] Y.Q. Sun, S. Simson: Wagon-track modelling and parametric study on rail corrugation initiation due to wheel stick-slip process on curved track, journal of Wear 265 (2008) 1193–1201.
- [11] H. Sayyaadi, N. Shokouhi: A new model in rail-vehicles dynamics considering nonlinear suspension components behavior, International Journal of Mechanical Sciences 51 (2009) 222–232.
- [12] Wei Wang, Gui-xian Li: Development of high-speed railway vehicle derailment simulation, journal of Engineering Failure Analysis 24 (2012) 77–92.
- [13] Takahiro Hosoi and Katsuya Tanifuji: Effect of Crosswind on Derailment of Railway Vehicles Running on Curved Track at Low Speed, International Journal of Railway Vol. 5, No. 2 / June 2012, pp. 93-101.
- [14] Shabana AA, Zaazaa KhE: Railroad vehicle dynamics, a computational approach. Boca Raton, FL: CRC Press; London: Taylor & Francis, 2008.
- [15] O. Polach, M. Berg, S. Iwnicki: Handbook of Railway Vehicle Dynamics, CRC Taylor & Francis Group, London 2006, pp. 359-421, Chapter 12.

-
- [16] Mădălina DUMITRIU: Influence Of The Suspension Damping On Ride Comfort Of Passenger Railway Vehicles, International Journal of Engineering, Science and Technology, Vol. 3, No. 8, 2011, pp. 54-65.
- [17] Saeed Hossein Nia: Daynamic modeling of freight wagons, Msc. thesis (Department of Mechanical Engineering, Blekinge Institute of Technology, Karlskrona, Sweden, 2011).
- [18] Nicolas Docquier: Multiphysics Modelling of Multibody Systems : Application to Railway Pneumatic Suspensions, Ph. D. Thesis (Louvain School of Engineering Institute of Mechanics, Materials and Civil engineering Centre for Research in Mechatronics, Louvain-la-Neuve, Belgium, November 2010).
- [19] Ramy Elsayed Shaltout: Multibody Approach For Railway Dynamic Analysis, Ph. D. thesis (Department of Mechanical and Material Engineering UNIVERSITAT POLITECNICA DE VALENCIA, Valencia, March 2013).
- [20] ____: SIMPACK documentation, SIMPACK Release 9.6, Copyright by SIMPACK AG©2014.
- [21] Watari, A. and Iwamoto, S.: Application of sensitivity analysis to vehicle dynamics, journal of Vehicle System Dynamics, Vol. 3 (2006) pp.1-16.
- [22] ____: SIMPACK documentation, SIMPACK release 8.6, 2003/SIMDOC v8.607 Copyright by SIMPACK AG© 2003.
- [23] Jingsong Zhou, Gang Shen, Hong Zhang, et al: Application of modal parameters on ride quality improvement of railway vehicles, journal of Vehicle System Dynamics, vol.46, pp.629-641, 2008.
- [24] ____: History of rail transport. Wikipedia, the free Encyclopedia. http://en.wikipedia.org/wiki/History_of_rail_transport. [Accessed 30 Aug 2014].
- [25]. ____: Rail transport in Ethiopia. Wikipedia, the free Encyclopedia. http://en.wikipedia.org/wiki/Rail_transport_in_Ethiopia. [Accessed 30 Aug 2014].

Appendices

Appendix A. Vehicle design data

The design data of the rail vehicle are collected from SIMPACK model data base from internet, i.e. WWW.simpack.com/modeldatabase/rail.

A.1 Rail vehicle

Geometry of a rail car and its design data are shown in figure A.1 and table A.2, respectively.

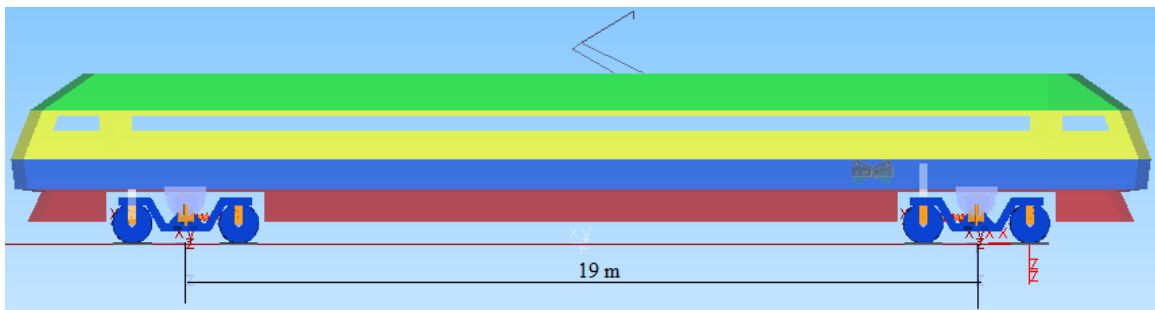

Figure A.1: Geometry of passenger rail car

A.2 Conventional bogie

Geometry of the conventional bogie and its design data are shown below.

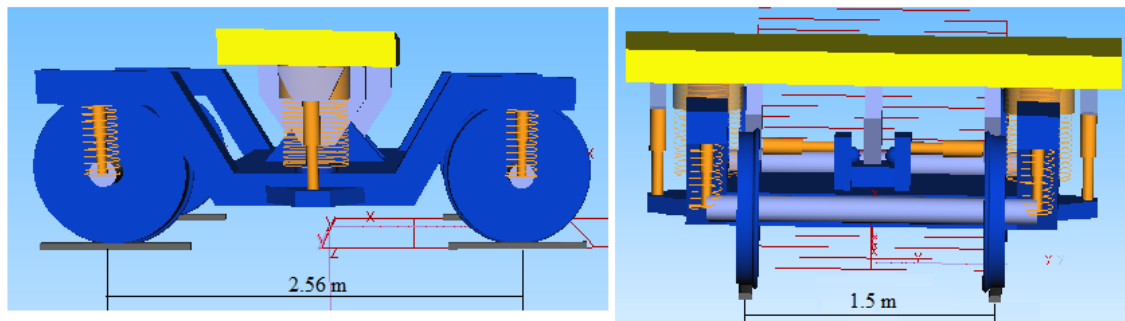
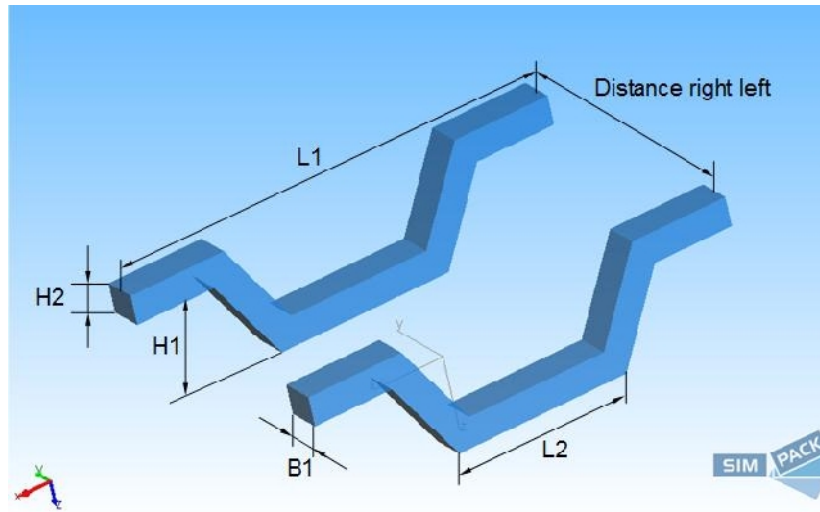

Figure A.2: Geometry of conventional bogie



b)

Figure A.3: Dimension of the bogie frame

Table A.1: Rigid body design data

Rigid body	Center of gravity (m) (x, y, z)-relative to part	Mass [Kg]	Area moments of inertia [Kg m ²] With respect to center of gravity		
			Ixx	Iyy	Izz
Car body	0,0,-1.8	32000	56,800	197e5	197e5
Bogie frame	0,0,-0.6	2615	1722	1476	3076
Wheel set	0,0,0	1813	1120	112	1120

Table A.2: Bogie frame dimensions

Dimension parameter	Value [m]
Distance right left	2
L1	3.2
L2	1.2
H1	-0.6
H2	0.2
B1	0.25

Table A.3: Suspension design data

Component	Stiffness/damping type	Damping (Ns/m)			Stiffness (N/m)		
		dx	dy	dz	cx	cy	cz
Primary spring (nom. Length 0.42m)	Translational serial	1.5e4	2e3	0	6e7	75e5	0
	Translational parallel	0	0	0	3.2e7	3.9e6	1.2e6
Primary damper (nom. Length 0.42m)	vertical	Figure A.3			0	0	6e5
Secondary spring (nom. Length 0.605m)	Shear spring with roll & bending stiffnesses of 10500 Nm/rad				1.6e5	1.6e5	4.3e5
Secondary damper	Vertical (0.605m)	Figure A.4			0	0	6e6
	Lateral (0.605m)	Figure A.5			0	0	6e6
Bump stop		Figure A.6					
Antiroll bar	rotational spring damper	Rotational stiffness about x axis = 940,000Nm/rad					

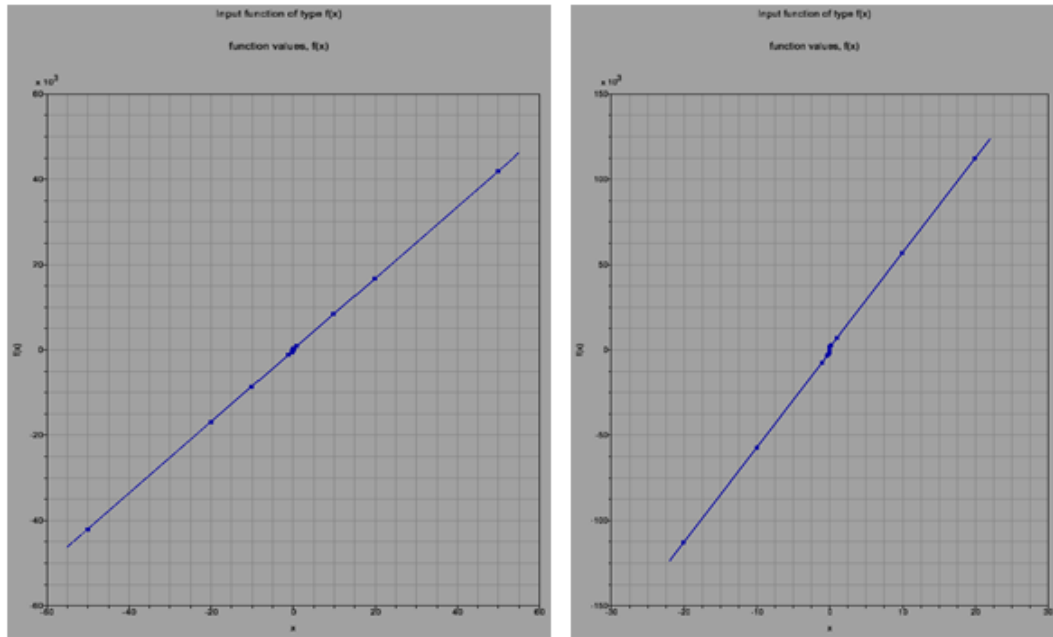

Figure A.4: Primary damper vert. damping (left) and secondary damper vert. damping (right)

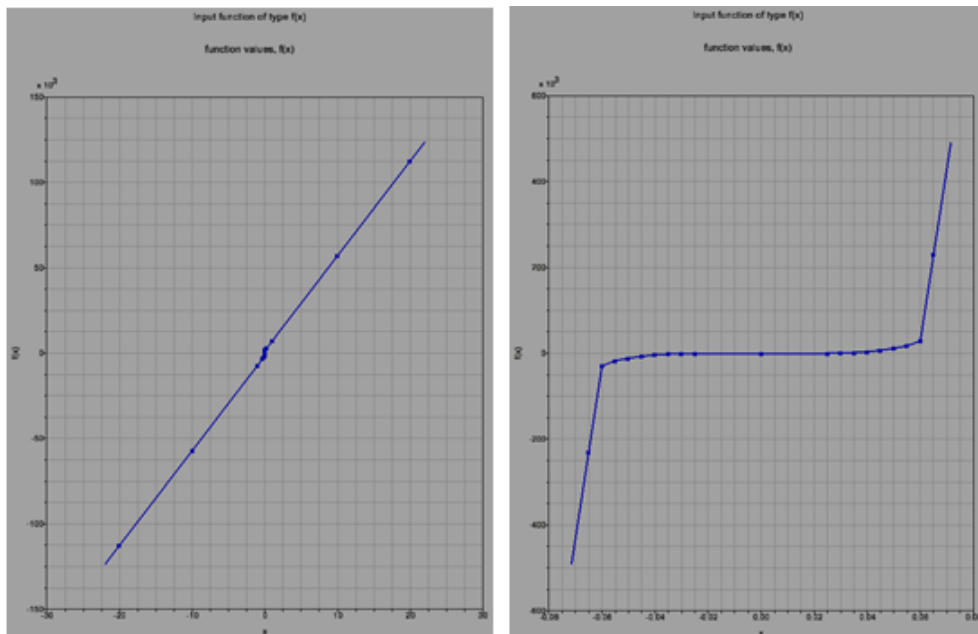

Figure A.5: Secondary damper vert. damping (left) and characteristics of bump stop (right)

Appendix B. Track data

B. 1 Rail excitation

The rail excitation used for the current study is a typical measured excitation, from SIMPACK documentation, and is shown in figure B.1.

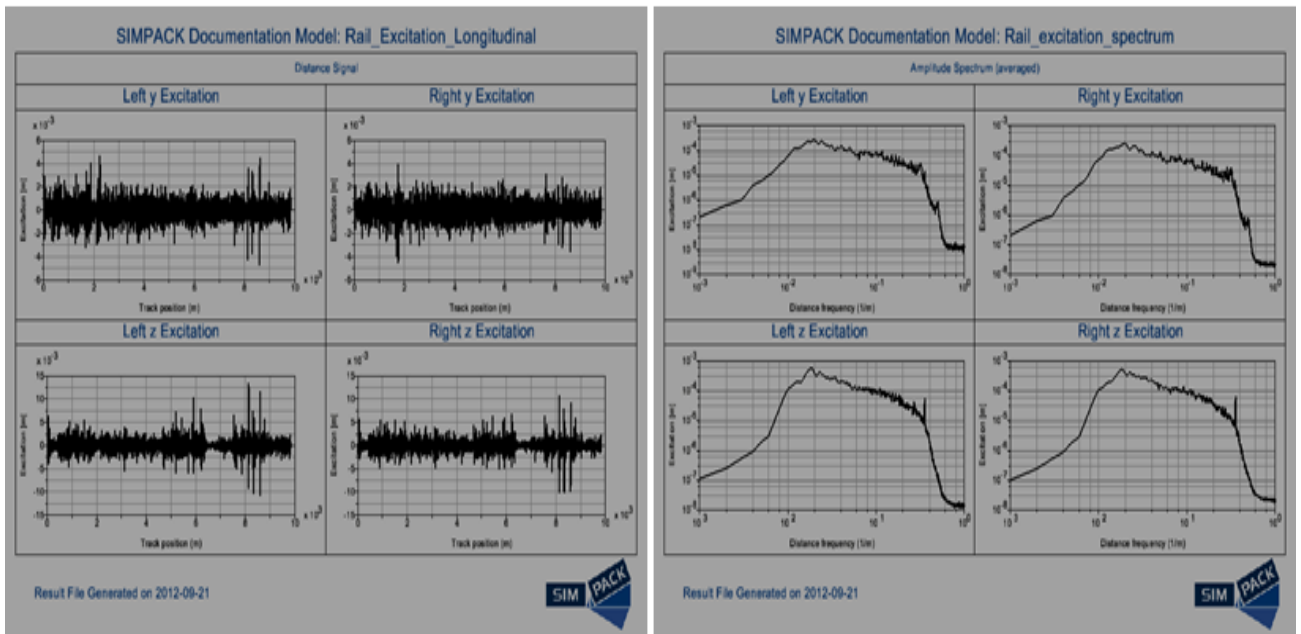

Figure B.1: Rail excitation: distance domain (left) and distance frequency domain (right)

Appendix C: Wheel rail data

C.1 Rail

The left and right rails are made of UIC 60 and geometries of the rails are shown in figures A.3 and A.4. The left and right UIC 60 rails are used with the following parameters:

- Rail cant (1: n): 40
- Lateral rail distance: 0.753m

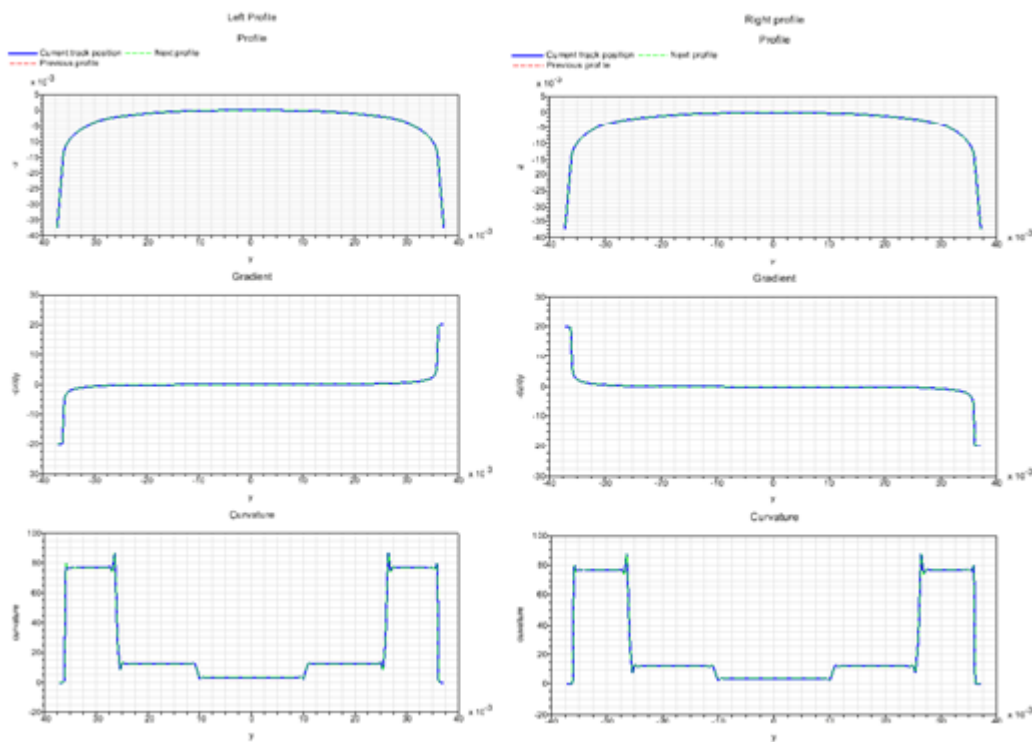

Figure C.1: Left rail profile (left) and Right rail profile (right)

C.2 Wheel

The data for the wheels are S1002 wheel profile, as shown in figure C.2, with nominal wheel radius of 0.46m, lateral wheel distance 0.75m and no un-trueness.

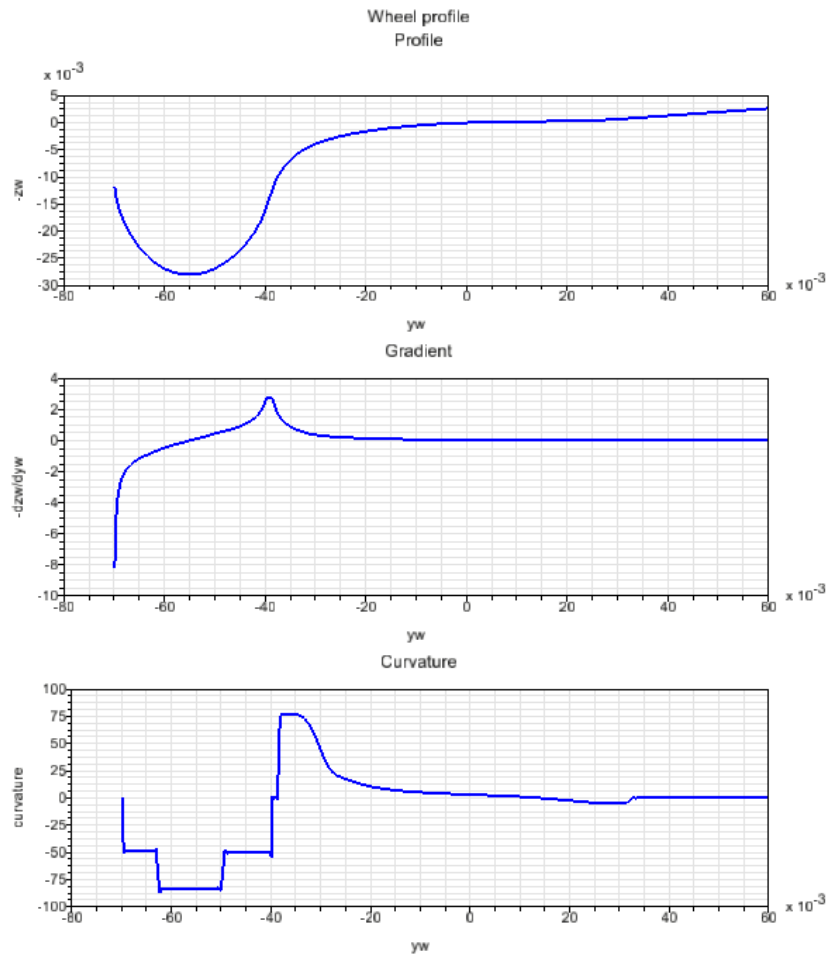

Figure C.2: Wheel profile

C.3 Wheel rail contact data

The wheel rail data used in the current study are:

- Wheel rail material parameters:
 - Young's modulus: 202276800000 N/m²
 - Poisons number: 0.277
 - Contact reference damping: 100000 Ns/m
- Friction coefficient: 0.4
- Equivalent conicity lambda: 0.186
- Roll angle coefficient sigma: 0.0372
- Contact angle coefficient epsilon: 15.81

Appendix D: Parametric analysis results

The parametric analysis results of the rail vehicle from SIMPACK are shown below:

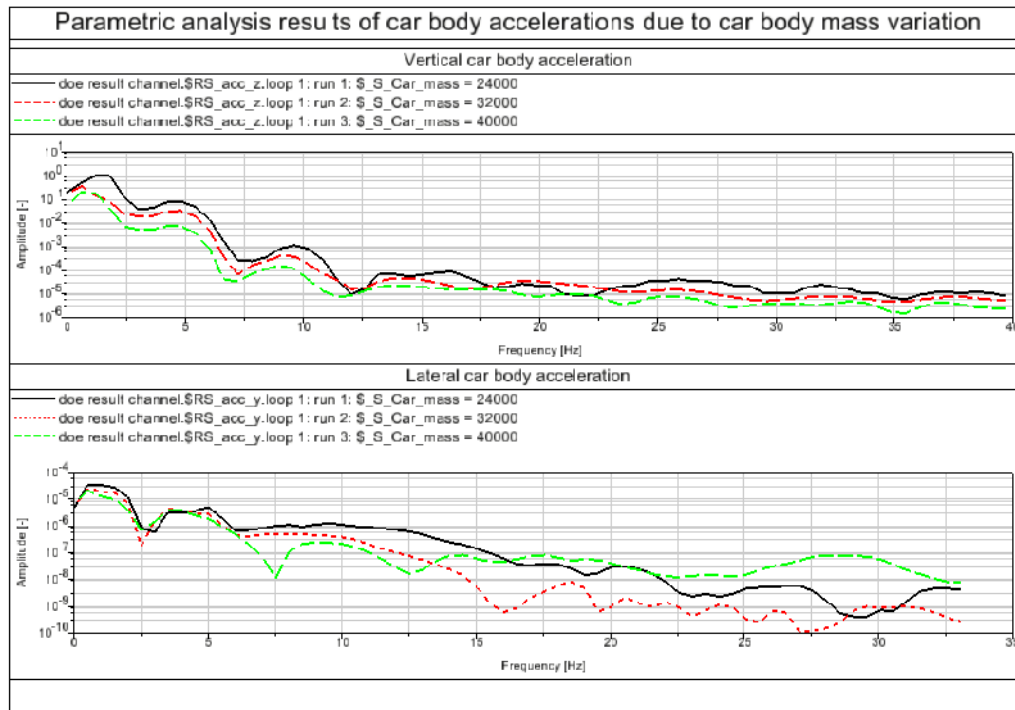

Figure D.1: Car body accelerations due to car body mass variation

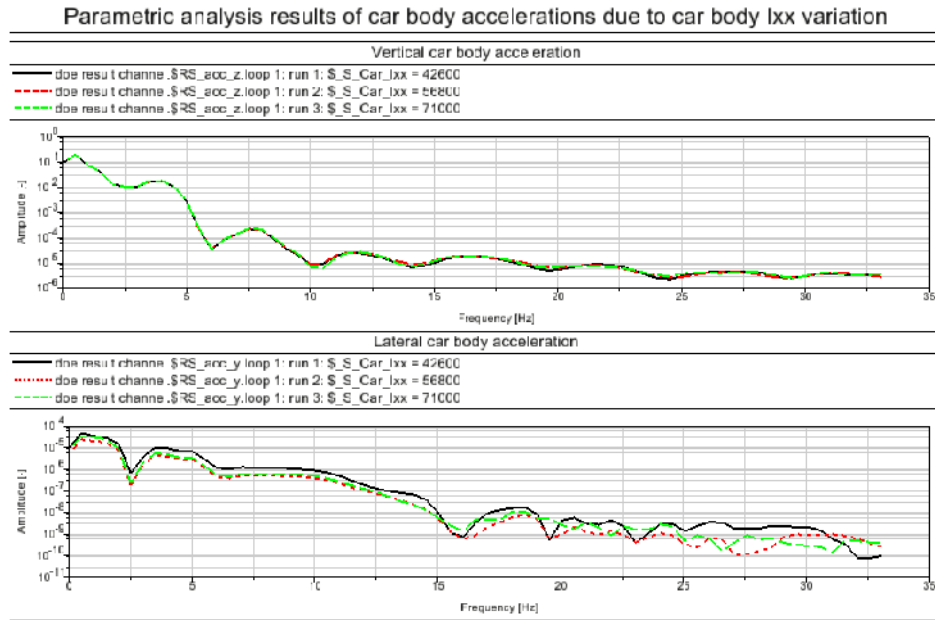

Figure D.2: Car body accelerations due to car body I_{xx} variation

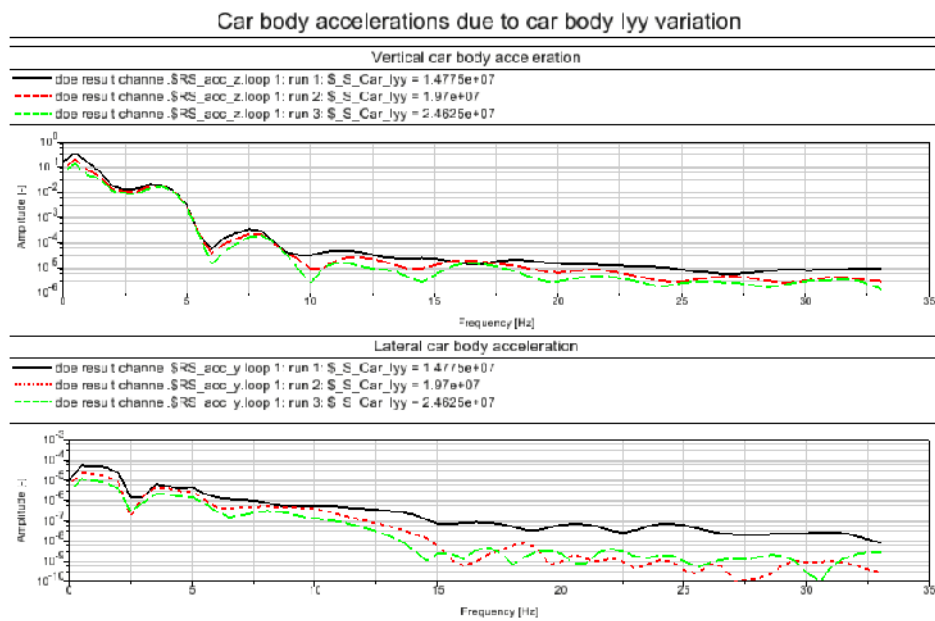

Figure D.3: Car body accelerations due to car body I_{yy} variation

Parametric analysis results of car body accelerations due to car body Izz variation

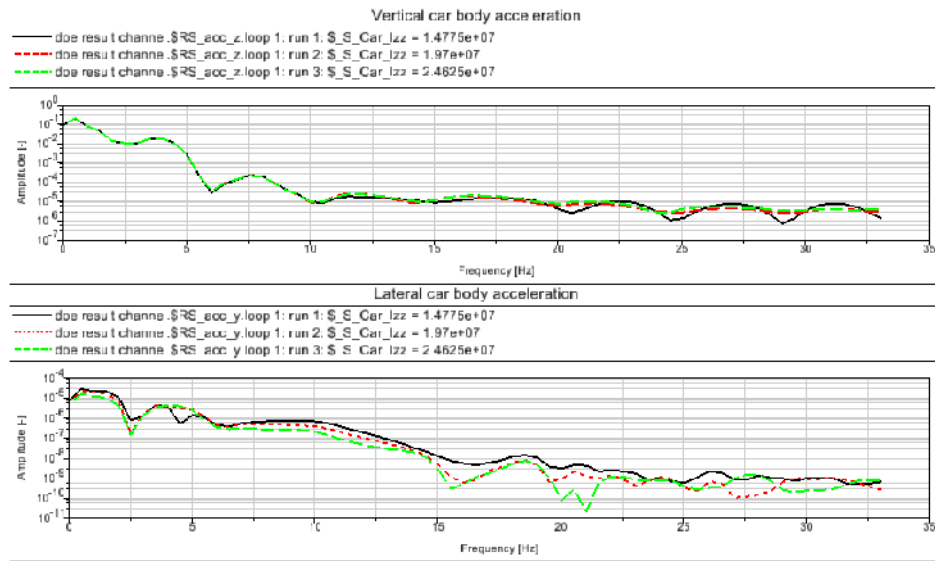

Figure D.4: Car body accelerations due to car body I_{zz} variation

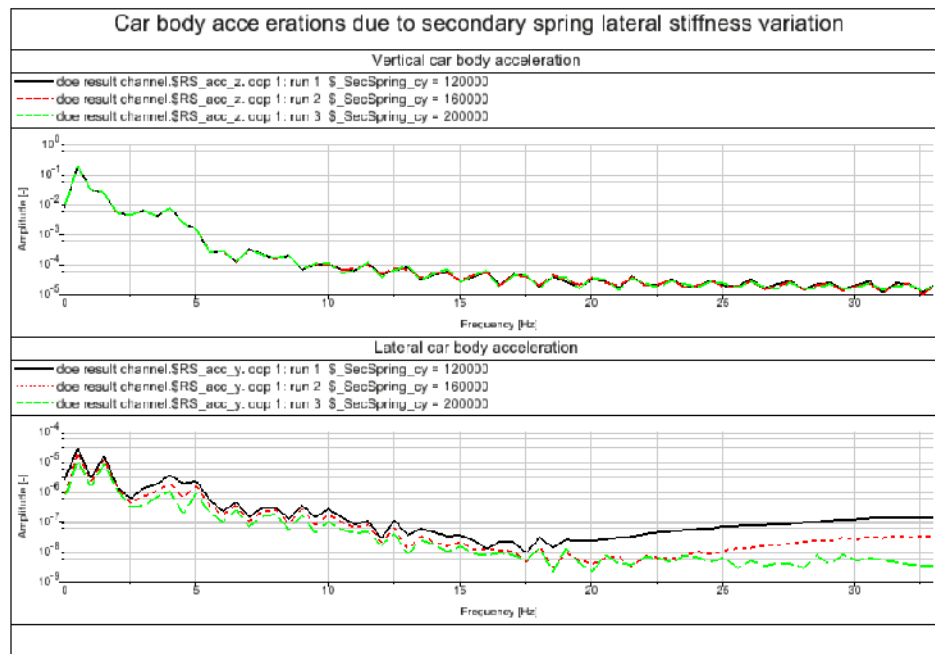

Figure D.5: Car body accelerations due to secondary spring lateral stiffness variation

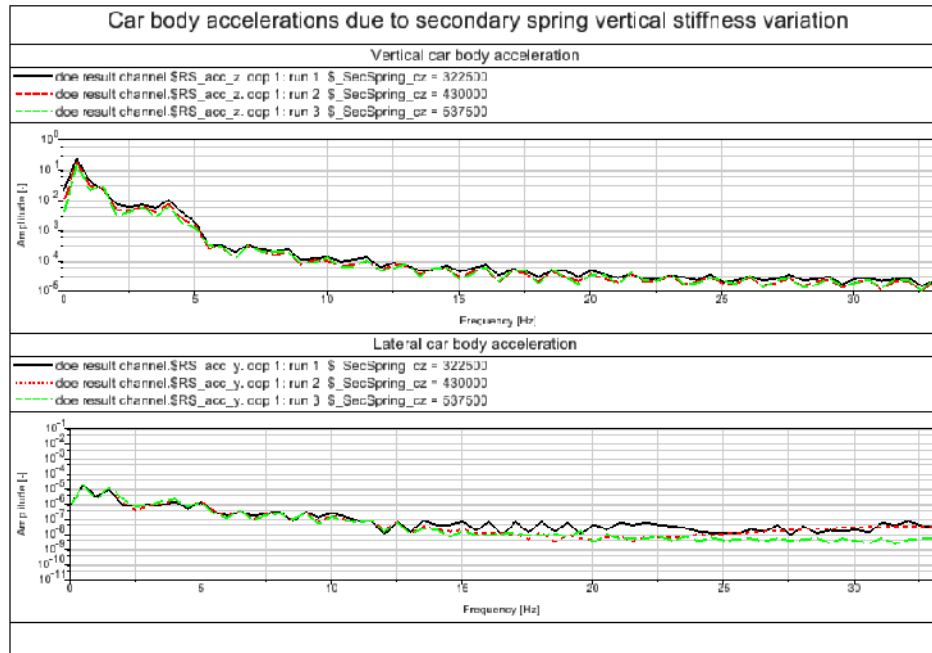

Figure D.6: Car body accelerations due to secondary spring vertical stiffness variation

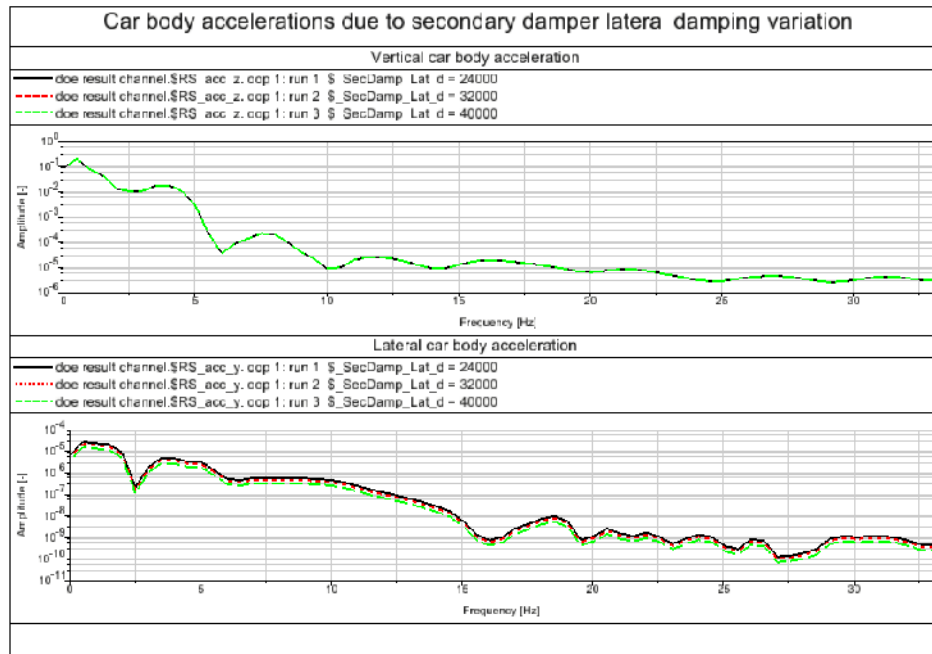

Figure D.7: Car body accelerations due to secondary damper lateral damping variation

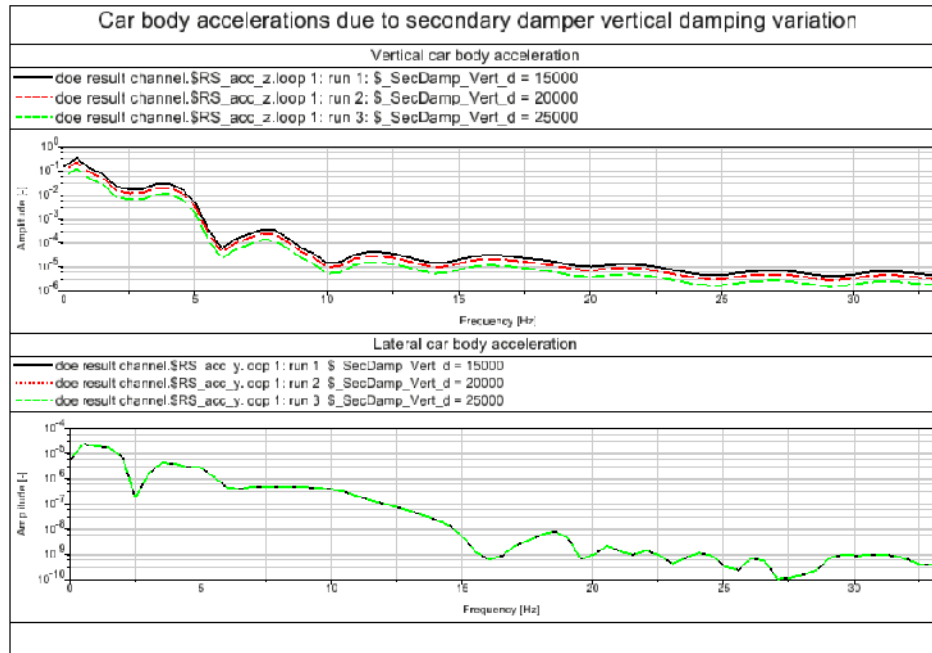

Figure D.8: Car body accelerations due to secondary damper vertical damping variation

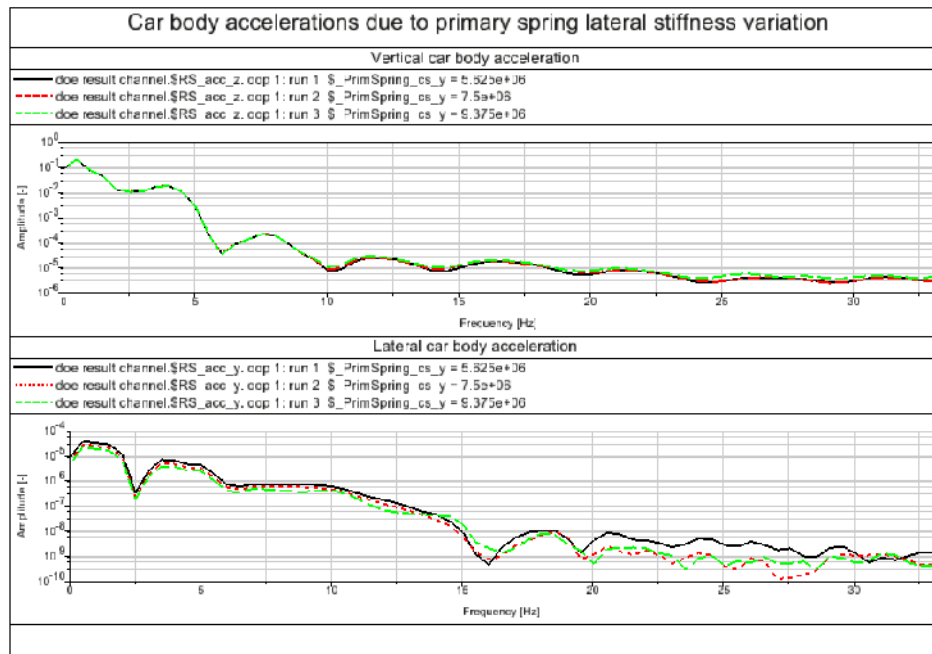

Figure D.9: Car body accelerations due to primary spring lateral stiffness variation

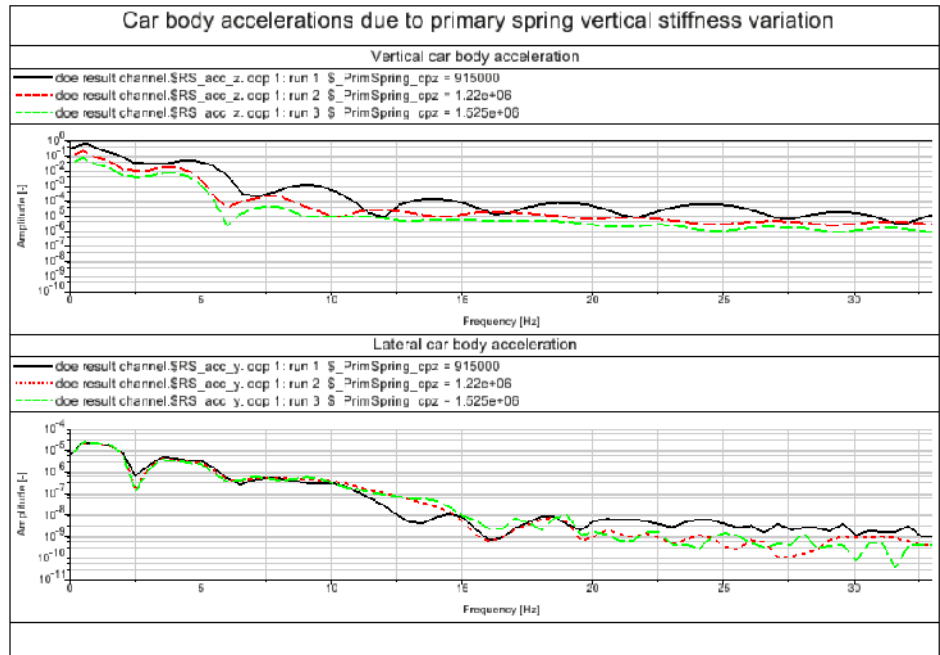

Figure D.10: Car body accelerations due to primary spring vertical stiffness variation

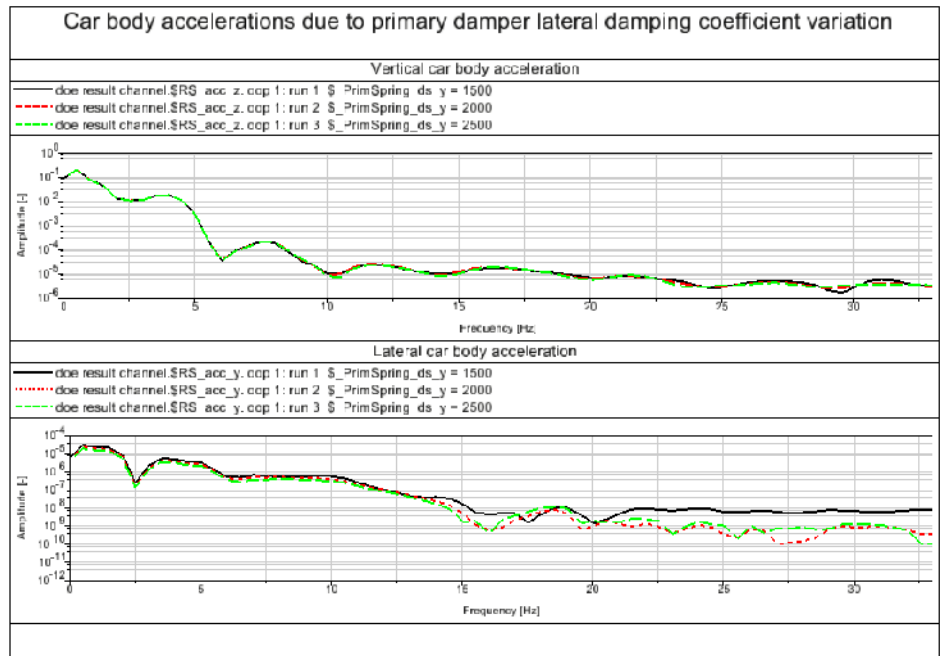

Figure D.11: Car body accelerations due to primary damper lateral damping variation

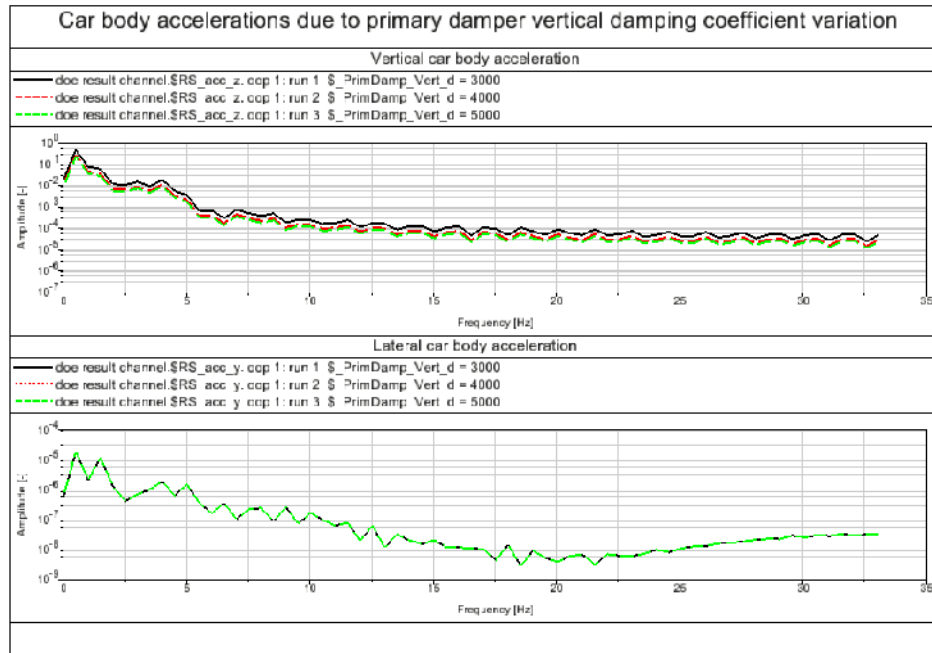

Figure D.12: Car body accelerations due to primary damper vertical damping variation

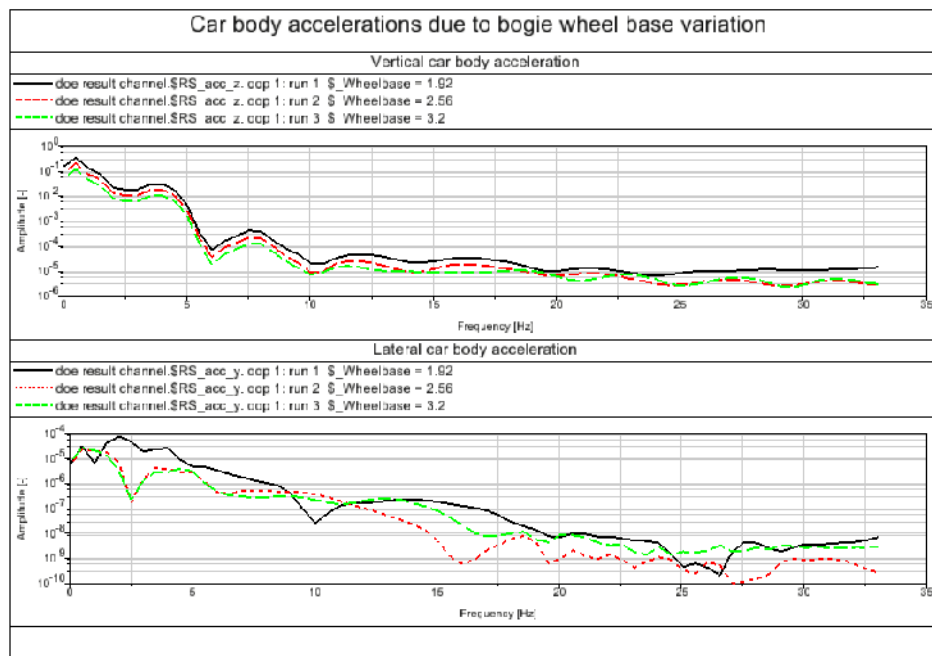

Figure D.13: Car body accelerations due to bogie wheel base variation