



ADDIS ABABA UNIVERSITY

ADDIS ABABA INSTITUTE OF TECHNOLOGY

SCHOOL OF MECHANICAL AND INDUSTRIAL ENGINEERING

***DESIGN AND ANALYSIS OF PICK UP AND TRANSFERE
WINDROW FORAGE TO TRAILER DEVICE***

**A Thesis Submitted to the Graduate School of Addis Ababa
university in partial Fulfillment of the requirement for the degree of
master of science**

in

Mechanical Engineering (Mechanical Design)

***By : Lemmi Girma
Advisor: Dr. Eng Zewdu Abdi***

January, 2014

ADDIS ABABA UNIVERSITY
ADDIS ABABA INSTITUTE OF TECHNOLOGY
SCHOOL OF MECHANICAL AND INDUSTRIAL ENGINEERING

***DESIGN AND ANALYSIS OF A DEVICE WHICH PICK UP AND
TRANSFERS WINDROW FORAGE TO TRAILER***

By : Lemmi Girma

Approved by Board of examiners

Zewdu Abdi (Dr .Eng)
Advisor

Signature

Date

Daniel Tilahun (Dr)
Internal Examiner

Signature

Date

Tamirat Tesfaye (Dr)
External Examiner

Signature

Date

Daniel Tilahun (Dr)
chairman of school

Signature

Date

ABSTRACT

This thesis present the design and analysis of pick up windrow forage and transfer to trailer device. A windrow forage is a narrow strip of forage that dries at a slower rate but does not require further manipulation before harvest. Most of harvesting technologies are complex in structure and expensive in cost. This paper will be solving the problem of complexity and expensive cost of existing technology. Main parts of machine component are selected by preparing concept selection based on created selection criteria. Pick up component are designed the way it can be self-adjusted for non uniform flat land surface (pick - valleys height up to 18 cm) by means of spring load. Picked up forage by pick up finger transferred to inclined feed dosing and then conveyed to trailer by means of pushing rod finger attach to flat belt conveyor. Power is transferred from tire to pick up component and conveyor by using flat belt. Design and design result of each part are included in this paper and material selection for most part based on the availability in Ethiopia. Some part of machine such as tire, bearing, bearing house (block), and spring belt are selected based on available standard catalog. 3D and 2D of different assembled and detail component are generated by catia that is power full and modern modeling soft ware and numerical solution also done by it which is finite element analysis package.

Key words: Concept Selection, Design, Analysis, 3D and 2D Model by Catia.

ACKNOWLEDGEMENT

I would like to take this opportunity to express my sincere gratitude and appreciation especially to my advisor, Dr.-Ing. Zewdu Abdi for his constant guidance, in valuable knowledge, and constructive idea in leading me to accomplish this project.

I also would like to express my sincere appreciation to all my friends, lecturers, faculty member and others, whose comment and help most in preparing this project. Last but not least my parent for giving me full support and encouragement for me to do my best in this project.

Table of Content

Contents	page
ABSTRACT.....	i
ACKNOWLEDGEMENT.....	ii
Table of Content	iii
List of Table.....	vi
List of Figure.....	vii
List of Nomenclature and Abbreviations	ix
Chapter One : Introduction.....	1
1.1. Background	1
1.2. Statement of the problem	3
1.3. Objective of study	3
1.4. Methodology.....	4
Chapter Two: Literature Review	5
2.1. Historical perspective	5
2.2. Production of Silage or Hay	6
2.4. Equipment used for forage harvesting	9
Chapter Three : Concept Generation.....	13
3.1. Introduction	13
3.2. Functional interrelation	13
3.3. Task specification.....	14
3.4. Establishing Functional Structure	16
3.4.1. Overall function	16
3.4.2. Decomposition of overall function.....	16
3.5. Possible solution for sub- function	18
3.6. Analyzing and Evaluating The Product Alternatives(Concept Selection)	19
3.7. Aternative Evaluation Tree Summary	28

Chapter Four: Mathematical Relation	29
4.1. Forward Motion	29
4.2. Power Transmission	29
4.3. Angular Motion on Pick up Finger	33
4.4. Helical Springs	35
Chapter Five: Embodiment Design	37
5.1. Introduction	37
5.2. Design component for Power Transmission	37
5.2.1. Selection of belt	37
5.2.2. pulley dimension	38
5.2.3. Shaft Diameter	40
5.3. Design of Pick Up Part.....	43
5.3.1. Spring Selection	43
5.3.2. Design of Pick up Finger	45
5.3.3. Design Pin	46
5.3.4. Pick Up Shaft	46
5.3.4.1. Design of Shaft Rod	46
5.3.4.2. Main Shaft Design.....	53
5.3.5. Pick-up Shaft Support	54
5.4. Design of Conveyor	58
5.4. Power Transmission System For Conveyor Head From Wheel of Tire	68
5.5. Structural Support Design	70
5.6 Design of traction connection component	73
5.7 Cost Estimation	75
Chapter six: Finite element analysis of main component	77
6.1. Analysis of pick up support in belt power transmission side.	77
6.2. chord of bucket analysis	79
6.3. Truss analysis	80
6.4. Block Analysis.....	81

6.5. Analysis of structure component.....	82
6.9 Analysis of Tractor Connection Part	84
Chapter seven: Conclusion and Future Work	85
7.1. Conclusion.....	85
7.2. Future Work.....	86
REFERENCE	87
Appendix A: Assemble	89
Appendix A-1: Over all assemble in 3D.....	89
Appendix A-2: Assemble of pick up Component.....	90
Appendix A-3: Assemble of conveyor part with structural support before add casing	91
Appendix B: Detail of part.....	93
Appendix B-1: Detail of Pick up component.....	93
Appendix B-2: Detail of conveyor part.....	100
Appendix B-3: Detail of structure support.....	109
Appendix C: specification of standard for recommended machine part	113

List of Table

Table 3. 1 : Task specification	15
Table 3. 2 Attribute matrix of force option.....	20
Table 3. 3: Attribute matrix for tire	21
Table 3. 4: Attribute matrix for power transmission.....	22
Table 3. 5: Attribute matrix for pick up finger controlling mechanism.....	23
Table 3. 6: Attribute matrix for pick up finger shape	24
Table 3. 7: Attribute matrix for concept screening of conveyor selection.....	26
Table 3. 8: Attribute matrix for scoring of conveyor selection.....	27

List of Figure

Figure 2 1 Machine used for mowing and windrow the hay	11
Figure 2 2 side delivery rake.....	11
figure 3. 1 Functional interrelation ship.....	14
figure 3. 2 Over all function.....	16
figure 3. 3 Over all function decomposition	17
Figure 3. 4 Alternative tree for sub function.....	18
Figure 3. 5 Result from Alternative tree evaluation	28
Figure 4. 1 Representation tire motion	29
Figure 4. 2 Representation of power transmission of belt with shaft	30
Figure 4. 3 Geometric description of pick up finger.....	34
Figure 5. 1 Shaft attach to tire wheel	40
Figure 5. 2 Description of weld area for shaft attach to tire wheel.....	41
Figure 5. 3 Pick-up head component after and before compression.....	43
Figure 5. 4 Area of hay may pick up	44
Figure 5. 5 Main shaft of pick up head	53
Figure 5. 6 Assemble of pick up head in 2D.....	55
Figure 5. 7 Pick-up shaft support in belt load.....	56
Figure 5. 8 pick-up shaft support in non belt load side.....	56
Figure 5. 9 Development of enclosing cylinder.....	57
Figure 5. 10 Free body diagram of conveyor head pulley	60

Figure 5. 11 Mounting method belt and road conveyor.....	61
Figure 5. 12 End joint of conveyor belt	62
Figure 5. 13 Chord conveyor in power transmission load	64
Figure 5. 14 Truss EF.....	64
Figure 5. 15 Chord support in non power transmission load.....	66
Figure 5. 16 Truss E'F'	66
Figure 5. 17 Block support in belt load applied.....	67
Figure 5. 18 Block support in non belt load applied.....	67
Figure 5. 19 Assemble of structural support.....	70
Figure 5. 20 Traction component.....	74

List of Nomenclature and Abbreviations

V_i - velocity of part or point ' i '

d_i - Diameter of part ' i '

T - tension Force (maximum tension)

T_1 - Tension in tight side

T_2 - Tension in slack side

T_c - centrifugal tension

t- thickness of a part

t' - time

P - power

L - length

F_f - Force of friction

F - Force

R' - Normal force

S' - Distance

a'_i - acceleration at point ' i '

a - height of part

R - radius

n' - total number

C' - index of spring

C - distance between pulley center

K - spring rate

P' - pitch

T_{tor} - torsion

J - polar moment of inertia

A - cross section area

D - mean diameter

U - strain energy

G - modulus of rigidity

Z - section modulus

I - second momentum of inertia

s - weld length

V' - volume

Q - flow rate

σ_{all} - allowable stress

σ_y - Yield stress

σ_{max} - maximum stress

σ_c - compression stress

$\sigma_{c,all}$ - compressed allowable stress

$\sigma_{t,all}$ - tensile allowable stress

σ_b - bending stress

ω_i - angular velocity of part ' i '

θ, α, γ - Angle

μ - coefficient of friction

δ - deflection

Chapter One : Introduction

1.1. Background

Domesticated animals have been used as power sources and/or as food during the entire recorded history of agriculture. Through grazing, animals are able to make use of grasses, legumes, and other forage crops that people cannot consume directly. The climate permits year around grazing in some parts of the world. Because grazing is selective and management intensive, however, forages are generally machine harvested and stored for later feeding. The two most common methods of preserving forage crops are as direct cut or field wilting. With direct cut harvest, silage is stored at the moisture level of the cut crop; field wilting allows the moisture content to decrease. Ensilage involves cutting the forage at 70% to 80% moisture, allowing it to field dry to 50% to 65% moisture, chopping it into short lengths to obtain adequate packing, and preserving it by fermentation in an airtight chamber. For hay harvest, the forage must be cut and allowed to dry to a moisture content of 15% to 23% before it can be stored (Srivastava, et. al. 2006). Hay has low bulk density and does not flow readily; silage has the same limitations, plus it will spoil if it is not fed soon after removal from storage. Thus, both hay and silage are often fed close to the point of production.

Forages are unique because they are harvested with high moisture content levels. Most grass and legume forage is allowed to partially dry by wilting before chopping; silage stored too wet produces effluents and causes poor fermentation. Silage that is too dry packs poorly and spoils. Therefore, once the crop has reached the proper moisture content the forage harvester and its complementary equipment must provide for a rapid harvest.

Forages are field dried in either a swath or a windrow. A swath approaches the width of the cut strip, generally leaving enough stubble uncovered to permit wheel traffic during subsequent operations. Swaths dry more rapidly due to greater area exposed to solar radiation, but they must be raked into a windrow for harvesting. A windrow is a narrow strip of forage that dries at a slower rate but does not require further manipulation before harvest. Forages to be made into dry hay are usually placed in a swath while those to be made into silage are placed directly into a windrow to control the drying rate. Tedding is sometimes used to spread the crop uniformly to

increase the drying rate. Leaves dry faster than stems with legume and grass-type forages. The leaves, especially in legumes, are higher in nutritional value than the stems. Brittle, dry leaves may be lost during raking and harvesting. To reduce such losses, the forage will be conditioned so that the stems dry at a rate approaching that of the leaves. Conditioning is a physical process of crushing or abrading the stems, or a chemical process that dissolves the waxy cutin layer of the stems. Either process increases the stem-drying rate by reducing the natural resistance to moisture removal from the stems. Grass and legume forages are usually cut with a machine that combines the cutting and the conditioning process. The mower-conditioner can place the forage into either a wide swath or a narrow windrow. A windrower can be used to harvest either forages or small grains, but can only place the material into a narrow windrow. A forage head picks up the windrowed product or cuts a standing crop. Windrow-pickups are used for silage, haylage and dry hay. Various pickup widths are available to match harvester capacity and windrow size, ranging from >1.5 m for the smallest mounted models to 3–4 m for big self-propelled models. After pickup the product is then carried by a feeding and dosing apparatus. During pickup a windrow product at some of the field loss may occur. The two major design factors that influence the loss at the pickup are the pickup speed relative to the forward speed and the speed at which the hay is elevated by the pickup into the machine² (Sharma, et.al). The forward speed must be reasonably matched to the pickup speed. The distance between pick-up finger must ensure a clean pick-up of the forage materials. High driving speeds necessitate a reliable and powerful pick-up.

Transferring the cut material to a trailer the conveyor mechanism will be selected. The pick-up finger used to pick-up material to feed-dosing to intake area ahead of conveyor. Amount of material conveyed must be related with amount of picked up materials. Once a trailer is filled up, the trailer can be detached and taken back to storage place for unloading and another trailer can be attached. The connectivity and dis connectivity from trailer is used to help trailer for different type of use.

windrow Shape and Condition

To produce a consistent, high quality hay and forage, the raked or merged windrow must be uniform to ensure the moisture is uniform throughout the windrow. Based on field experience and observations, the rotary rakes produce a more uniform and less roped windrow than wheel or parallel-bar rakes. Windrow inverters and mergers will not produce a roped windrow but can

often produce non-uniform windrow if the belt does not properly take the crop off the pick-up. In all cases, the equipment must be properly adjusted and operated to obtain the most uniform windrows. Producing windrows free of rocks, soil, and other debris to avoid problems is important with respect to forage harvester knife wear, knife damage, clostridia fermentation (especially in high moisture silage) and excess ash content in feed. In some methods of forage harvesting, the forage is formed into windrows that can then be picked up directly by the harvester. This is common practice when harvesting forage for silage or where the climate is very dry. When dry hay is desired in humid climates, the forage is placed in a swath and then raked into a windrow.

1.2. Statement of the problem

For domestic animals forage likes grass and legumes is needed. In our country there is not enough technology to manufacture forage harvester and also the type of forage harvester those available in the world are not easily obtained because of their cost. The other problem in our country is lack of technology which producing the product used for the harvesting technology. So, in this paper design the method a forage material lifting and transferring device which can be developed in our country and also to make more simple.

The aim of this research is to solve the cost problem accrued due to its import from foreign country. Cost reduction mechanism by design the way harvesting technology can be produced in our country, by using the motive power from car to others like horse or by making the mechanism in a way it can be assembled with other vehicle which used for other agricultural works.

1.3. Objective of study

- General objectives:- Design and development of a device which used to lifting and transferring cut forage into a trailer.
- Specific objectives:-
 - Studying the effects of the material by its length, weight, amount of moisture contents on the material lifting device.
 - Design and selection of part such as
 - Pick-up mechanism

- Design of pick-up support like shaft,bearing selection
- Design lifting and transferring mechanism
- Identify power source
- Identify the means of drive

1.4. Methodology

➤ Literature collection

Literature collection is the process to get the information need to proceed the work. Therefore,

- ✓ identification of the type forage mostly used by users which used to study their property.
- ✓ Study the physical property like length,content of moisture,weight of forage per volume(density) and etc.
- ✓ Describe the effect of those physical property on the full process.
- ✓ Study the profitability by comparing the amount of forage harvester can produce(m^3/s) with loss by time, energy and etc. Based on this profit we can decide the specification like input energy (to know the amount of total power need),input material, speed and etc

➤ Design and analysis

Design and analysis is the procedure used to calculate the dimension of every part, speed of movable part ,maximum force applied on the part, bending effect, shearing and etc. The following are some of work can appear:-

- ✚ Selection of material which can be obtained in our country
- ✚ Evaluate the alternative mechanisms
- ✚ Calculate the amount of the maximum force the material can stand up without fail
- ✚ Calculate the dimension of part will be designed
- ✚ Selection of standard material which can get from market like bearing, sealing, etc
- ✚ Identify the source of input power
- ✚ Selection of the best connecting mechanism
- ✚ Modeling 3D by catia

Chapter Two: Literature Review

2.1. Historical perspective

It has been over 50 years since the first successful automatic pickup, self-tying hay and straw bale appeared on a farm in Pennsylvania. This design, later built by New Holland, led to the development of the modern small square hay baler that is still popular in many parts of the country. All of the major and several of the short-line (manufacturers that only produce a limited type of farm machinery) farm equipment manufacturers still produce small square balers. As with almost all other farm/ranch operations over the past fifty years, continued modernization and increased mechanization has helped to reduce the labor (number of people) required for making hay. In the early to mid-1900s, making hay was almost a community event on the farm/ranch. The stationary balers of that time required that hay be brought to the implement. Operators manually tied the bales with twine/wire after the hay was fed through the machine. Today, tractor-pulled hay balers with self-feeding pickups, automatic knitters (devices that tie a knot in the wire or twine used to secure the baled hay), and bale throwers, which toss the finished bale into wagons, are a common sight on farms/ranches throughout the United States.

Although it was not always the case, the majority of hay made across the United States today is baled hay. An estimated 151 million tons of hay was harvested in 2002. Forage harvested as dry hay is included in many rations fed to dairy and beef animals, horses, goats, and sheep. Dry hay is also a cash crop, rather than a feed source, for some farmers/ranchers. Harvesting and handling hay with new and/or modified farm machinery is physically easier and more accessible to people with and without disabilities. Most of the adaptations made will be associated with the operator's position on the tractor or self-propelled machine. Also, bale-handling alternatives are available that can change the skills and strength required of the worker to complete tasks associated with hay production. For all farmers and ranchers, reducing the manual labor required to make or handle hay bales has been a welcome change. (American Society of Agricultural Engineers - ASAE)

2.2. Production of Silage or Hay

The production process of silage/hay may be divided in four stages:

1. Forage harvesting
2. Transport to the silo
3. Compaction
4. Sealing (air-tightness).

Silage Harvesting

Silage can be a convenient and economical feed for the cattle industry. Some producers routinely produce silage, but others only produce silage when field drying is difficult or impossible. Crops such as corn and sorghum are not ideal for hay production because they contain considerable moisture at the optimal harvest time, and their thick stalks delay drying. Warm-season grasses like bermudagrass and bahiagrass can be harvested as hay. Harvesting such grasses as silage may reduce harvesting losses and allow a more timely harvest, thereby improving forage quality.

Silage is high moisture forage, stored in the absence of oxygen and preserved by acids produced during the fermentation. During ensiling, bacteria ferment sugars in the plant to organic acids that lower the pH of the silage to levels that inhibit the growth of undesirable organisms. The silage remains preserved as long as air is kept out because spoilage causing yeasts in silages remain dormant in the absence of oxygen. Entry of oxygen into the silo revives the yeasts and may cause spoilage.

Properly made silage has several advantages over hay, including the following:

- Lower probability of weather-related damage or delays during harvest
- Lower field, harvest, and storage losses
- Greater flexibility and fit for many livestock feeding programs

Disadvantages include:

- Higher moisture content results in heavier forage that is less economic to haul
- Requires specialized equipment for harvesting, storing, and feeding operations
- High loss potential if silage is not made well

- Less marketable if the silage is not fed on the farm
- Shorter shelf life after the silo is open

The type of livestock, available machinery, soil type, rainfall, availability of irrigation, and potential yield are important considerations in deciding which crops to plant and store as silage.

Corn silage is usually considered the best silage because of its high energy concentration, which can be used to optimize animal performance. The best time to harvest corn silage was previously thought to be when the grain is denting and the milk line has moved 1/2 to 2/3 of the way down the kernel.

Good silage can also be made from forage sorghum, sorghum-sudan hybrids, soybeans, and other warm season annuals, but they are lower in energy than corn silage. Forage sorghum is usually direct cut, but the moisture content at optimal maturity for harvest is often too high for proper ensiling. Therefore, choose hybrids with low moisture ratings when possible, and aim to harvest when the dry matter concentration is 30%–35%. Sorghum-sudan hybrids, soybeans, and cowpeas usually have high moisture concentrations at optimal maturities. Therefore, wilting is often needed to ensure good silage quality.

Excellent silage can also be made from cool-season annuals, such as small grain cereals and ryegrass when they are harvested at optimal maturities. Wilting is advisable if the dry matter at harvest is less than 30%. Silage production from bermudagrass, stargrass, limpograss, perennial peanut, and alfalfa is also feasible. However, low sugar contents and high buffering capacities (resistance to change in pH) make it more difficult to ensile these crops. (A. T. Adesogan)

Hay Harvesting

The timing of seed harvest is one of the most important decisions a grass seed grower will make. Grasses need 20-30 days after flowering for seeds to properly mature. This will vary because the period of flowering and seed development lasts from several days to two weeks. As a result, seed heads emerge at different times, which causes uneven ripening.

Hot, dry weather shortens the ripening time. Cool, moist conditions delay seed maturity. Grasses grown under irrigation tend to have a higher ash content, which can result in more breaker experienced with dry land produced grasses. Moisture testing of the entire seed head (35-50%) is

also a useful indicator of when to swath. Most grasses will hold their seed for 10-15 days, but the time from medium dough to seed shatter can be as short as three or four days. Seed shattering will depend on: the grass species, stage of maturity, the variety, the degree of lodging, and wind, rain or hail. Check fields often to determine when the crop is ready to harvest. Here are some guidelines that indicate when a seed crop is mature enough to harvest.

- A crop is ready to harvest when seed is at the medium to hard dough stage (moderate to hard pressure with a thumbnail will dent the seed of large-seeded species). Swath when 75 per cent of the seed heads have matured.
- Grass seed heads generally ripen from the top down. When the tips begin to shatter, the crop is ready to harvest. Harvest immediately if seed heads shatter when gently struck against the palm. A crop is ready to swath if seed heads shatter when roughly struck against the palm. (*Dipl. Ing. agr Heinz-Günter G. and Dr. Johannes T.*)

Treatments of Hay or Silage Before Transport to Silo (storing area)

The principal treatments after cutting prior to conservation of forages are, in order of importance: *chopping*, *wilting* and *conditioning*. Chopping is necessary to obtain good compaction to exclude air in order to promote a rapid initiation of the microbiological processes and to take optimum advantage of silo capacity. Chopping is done with specialized equipment. This may be a **stationary chopper** used when the forage is entered into the silo, or a **pick-up trailer that chops** the forage when it is collected in the field. Wilting forage before ensiling has many advantages. When dry matter levels are between 30 and 35%, effluents will not be produced, the development of undesirable microorganisms will be reduced, better fermentation will be promoted and intake increased. Anti-nutritional metabolites (e.g. tannins and alkaloids) in certain forages (e.g. herbaceous and woody legumes and cassava leaves) will be eliminated or reduced. However, these species tend to lose their leaves during handling when dehydrated to over 40% dry matter. The field-drying time required to reach an optimum dry matter content depends on the species and on the weather conditions. The time may vary between 4 and 24 hours depending on the thickness of the stems. Drying time can be reduced when a mower conditioner is used, which crushes the stems. Crushing cuts the fibers and compresses the forage so that cellular juices will be extracted. Tedding the cut forage immediately after cutting and one more time

afterwards will reduce drying time. The shorter the field drying time the lower will be the risk of rain damage.

In most parts of the country, harvesting hay includes the use of a mower, rake, and baler. A healthy standing crop of hay (hay may consist of legumes, such as alfalfa or clover, and grasses, such as orchard or timothy) will have a water content of 80 to 90 percent. First, the mower or mower-conditioner cuts the standing crop and lays it in a windrow to allow the hay to dry in the field until it reaches safe storage water content levels. Next, a rake and/or related equipment moves the windrow to aid the drying process, creates a narrower windrow and/or brings two or more windrows together for a more efficient baling operation. After the raked hay has dried to the proper water content, the baler gathers hay from the windrow and compresses the hay into a denser package (bale) for ease of handling, storing, and feeding. In semi-humid climates, the hay should be protected from moisture due to precipitation (rain, sleet, snow, etc.) or absorption through the ground. A low-cost storage building will meet these needs. In semi-arid areas, the hay packages may be stored without any shelter.

2.4. Equipment used for forage harvesting

The grass silage crops need mowing, windrow turning, swath broad-turning and swathing. Mowing, windrow turning, swathing using your own or syndicate farm resources also serve to step up production costs which must be estimated at 5 – 6 €/t of forage. Harvesting and transport are contingent on the harvesting procedures used and the transport distances involved.

To date, ensiling grass with short cut silage trailer is the equipment of choice of single farms for smaller land surface areas. However, its modest shock power and the cost of investment involved in the farmer's own harvesting chain is no longer able to keep up with the nutritional-physiological requirements of today's high-performance cows, on the one hand, or the economic framework parameters, on the other. To handle one-day ensiling, high-performance rotational feeders mounted on large capacity loader trailers are now available, offering storage capacities from 25 up to 40 m³ with prices starting from 40,000 €. With tractors as of 150 hp, only high yields allow for this type of capacity to be fully used. With these types of machinery, it is difficult to see how optimal price performance ratios can be guaranteed for individual farms or even syndicated farms, thus the need for higher capacity utilization. In addition to initial price, the energy used for blower the forage also high i.e. to blow 8.34 kg of forage the power required is around 17kW. Such types of forage harvesting machine join to tractor and all power are get

from engine power and the tractor has only used for harvesting forage rather than make flexible agricultural work.

The pick-up finger for loader trailer are rigid. That means the work area for such type of machine only when surface area of grass land is smooth. Loader trailer are effective if the surface of grass land prepared as plot surface (roughness is low). In our country preparing the land grass as plot surface (smooth surface) it may take high cost and power. Therefore, pick-up finger height controlling mechanism may solve the problem.

But the loader trailer still has a couple of key benefits up its sleeve:

- high shock power
- good cut quality
- low power demand and therefore low energy consumption
- simple logistics
- low risk of failure
- high net loads
- foreign bodies safety against stones
- good complement to the customer's existing harvesting mechanizations

A wide variety of methods for harvesting and handling dry hay are available. Each method requires using specific "haying" equipment to complete the various tasks. With careful selection, however, most hay harvesting and handling tasks can be adapted to the abilities of the worker.

Mower

The first step in harvesting hay is mowing the standing crop and laying it in windrows. Most mowers used for hay production today have a conditioning unit that ruptures the stems with rollers or impellers for more rapid drying. With legumes, the leaves dry rapidly while the stem with its waxy surface dries more slowly. This is especially important in the semi-humid areas where the goal is to insure rapid drying and reduce the risk of losses in yield and hay quality caused by precipitation. In semi-humid areas, the hay will have to dry for three to four days for the water content to reach the 16 to 30 percent range.



Figure 2 1 Machine used for mowing and windrow the hay

The machines used for mowing are either self-propelled or pulled by a tractor.

Rake

A rake is designed to move the mowed windrow across the soil surface or remaining crop stubble, creating a narrower windrow that will dry more rapidly. Raking should be completed before the crop reaches 40 percent water content. At lower moistures, the leaf loss can be excessive, especially in alfalfa. Hay rakes come in many different styles.



Figure 2 2 side delivery rake

One style of rake is towed behind the tractor while another style is mounted on the rear three-point hitch. One style of rake can even be mounted on a tractor front-hitch. Some rakes are designed for side-delivery of a single mower windrow, while others are designed to combine two or more mower windrows. Some parts of the country even further classify rakes as rotary, tedder, or wheeled.

Other rake-like machines used to move windrows are called inverters and mergers. The inverter simply picks up a windrow and lays it on the ground inverted (turned over), which aids the drying process. More recently, mergers have become available that pick up one or two windrows and lay it on top of the adjacent windrow. Unlike hay that is raked only, inverters and mergers reduce the risk of rocks in the windrow.

Pick-up trailers

Pick-up trailers must have a mechanism that can raise the forage off the ground, chop it and send it towards the collection bin with a varying capacity. The unloading mechanism can be lateral, at the back or with a moving floor. Trailers with a lateral unloading system are practical for silos

that are more than 6m wide because they allow for rapid unloading. In the case of wilted silage it is important to have large trailers, since forage density decreases linearly with increasing dry matter content.

Methods of compaction

The method of compaction depends on the silo dimensions. In vertical silos of 2 t or less, compaction can be achieved by a person walking over the successive layers of forage. In horizontal silos, less than 4 m wide, compaction may be done by animals or people walking over the material. Larger silos require wheel or caterpillar tractors. The minimum width for mechanical compaction is 4 m. The tractor wheels or caterpillar must always pass over the inner border of the trail left during the previous passage, in order to guarantee homogeneous compaction.

Mud or water accumulation around the silos must be avoided to prevent contamination of the forage.

Equipment for distribution of additives

Different implements are used for the application of additives, depending on the type of additive and whether it is added during chopping or after the material has been deposited in the silo. With large amounts of silage, the best way to distribute the additives is directly at the forage elevation system associated with the pick-up trailer taking advantage of the turbulence it creates. This will guarantee an efficient homogenization of the additive.

Chapter Three : Concept Generation

3.1. Introduction

Concept generation answers the question of “how” the product will satisfy the needs as mapped into the functional specifications. The concept generation stage of product development is where the skill, experience and creativity of design team are used to generate designs which address the identified needs of the clients and the users to create a factor. Ideas are like prototypes. They need to be tested to verify they fit customer and client needs. Once concepts are generated, we can present them in a variety of formats to enable full understanding and evaluation of the concepts. Concept generation is analyzed in two ways, implicitly through sketches, and then explicitly through enumerated design alternatives. First, ideas are observed through sketches created by designers. Sketching is an integral part of the engineering design process and provides one form of evidence of design activity. Second, method examines concept generation more directly through the quantity of ideas created through brainstorming and in morphology charts. Brainstorming is free-form, unstructured concept generation activity. Morphology charts are hierarchies of alternative embodiments that can fulfill each of a device’s functions [Zwicky 1969].

3.2. Functional interrelation

Functional interrelation is a method for analysing and developing a function structure. Function structure is an abstract model of the new product without materials features such as shape, dimensions and materials of part. Function tells what the product must do whereas its form or structure, conveys how the product will do it. Functional interrelation includes logical flow of energy, material and information between object.

Cut material lifting and transferring device machine pulled or pushed by vehicle or animal. Due to force application the machine move forward on the windrow grass by rotation tire. Flywheel or pulley connect to tire wheel, then power transfer from tire wheel to pick up header by power transmission equipment. Pick up header consist shaft and pick up road which used to pick the material and transfer to material hold device. The effect of non uniformity of land surface on the pick up finger may be solved based on the height controlling mechanism such as spring,

hydraulic system and etc. The material stored on the material hold device must be conveyed to trailer. The source of power for conveyor can be by power transmission from tire wheel or pick up header.

all procedures are summarized as following figure

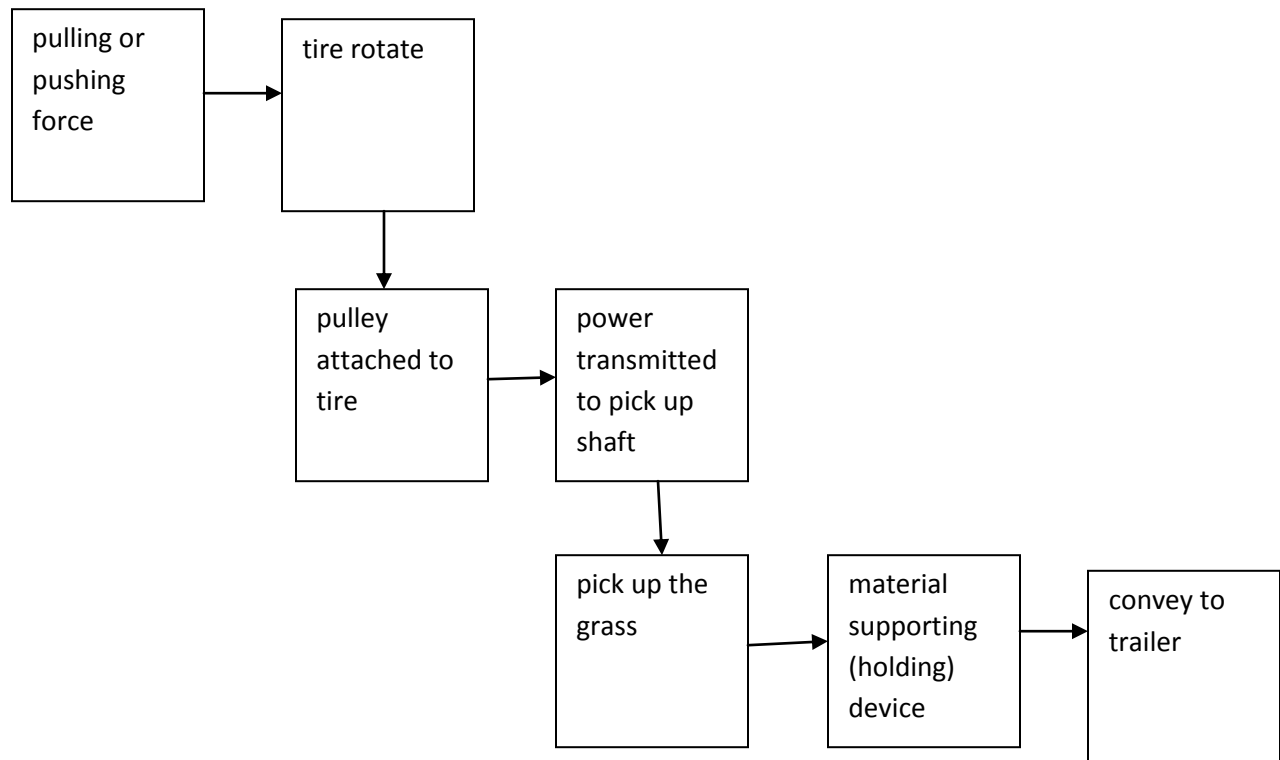

figure 3. 1 Functional interrelationship

3.3. Task specification

Task specification is a collect of information about the requirements to be embodied in the solution and also about the constraints.

Note: D means demand and W- wish

Demands are requirement that must be met under all circumstances but wishes are requirements that should be taken into consideration whenever possible. The distination between demand and wishes is also important at the evaluation stage.

Table 3. 1 : Task specification

Change	D or W	Requirmenrs	Resposi ble
		Geometry:	
	D	Height of tire from ground to its center(radius of tire) is 15.45 in (392.43 mm)	
	D	Depth between front tire is 1.75 m	
	D	Pickup header depth 1.5 m	
	W	Space between shaft on tire and shaft on the pick up finger is up to 1 m	
	D	Length of pick up finger from ground to cylinder of which inclose pick up shaft is 0.20m	
	D	Space between pick up road along length is 0.15m	
	W	Space pick up road from normal ground surface is 2mm	
	W	Height of axis of pick up shaft from ground is = 42cm	
	D	Height to be convey 3.5 m	
		Kinematics:	
	D	Tire rotate in clock wise direction	
	D	Pick up rotate in counter clock wise direction	
	D	Drum or pulley of conveyor rotate in clockwise direction	
	D	The machine move forward with speed up to 1 m/sec	
	W	Material move in uniform amount and speed.	
		Force :	
	D	Enough friction force between tire and land which resist slip must be available.	
	W	Impact force on pick up road due to non uniformty of land surface is < 10N , also assume weight of grass pick up will be < 10 N	
		Material:	
	W	Moisture content of materials can be any value.	
	W	Tempereture is the same with envirometal condition	

3.4. Establishing Functional Structure

The functional basis uses function and flow words to form a sub-function description as a function and a flow (i.e., a verb-object format). Generation of a black box model, creation of function chains for each input flow, and aggregation of function chains into a functional model are the sequence of steps that lead to the repeatable formation of a functional model in their approach. The black box model is constructed based on the overall product function and includes the various energy, material, and signal flows involved in the global functioning of the product. The detailed functional model is then derived from sub-functions that operate on the flows listed in the black box model.

3.4.1. Overall function

Overall function describes the general relation between input and output. All functional process between input and output represent by black box. The black box contains all the functions which are necessary for converting the inputs into the outputs

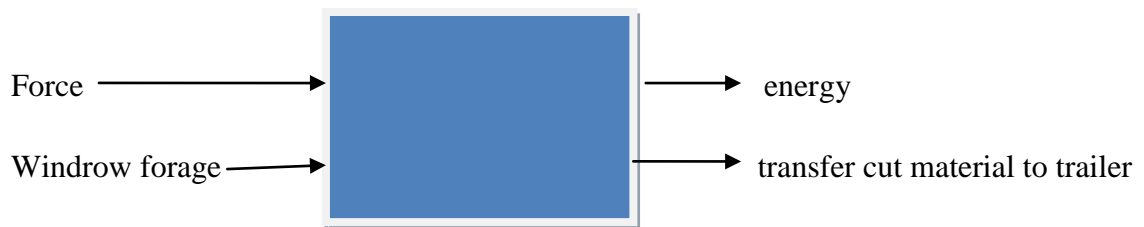

figure 3.2 Over all function

3.4.2. Decomposition of overall function

Just as a technical system can be divided into subsystems and elements, so a complex or overall function can be broken down in to subfunctions of lower complexity. The combination of individual subfunctions results in a function structure representing the overall function.

The aims of breaking down complex functions are to:

- ✚ determine subfunctions that facilitate the subsequent search for solutions

✚ combine these subfunctions into a simple and unambiguous function structure

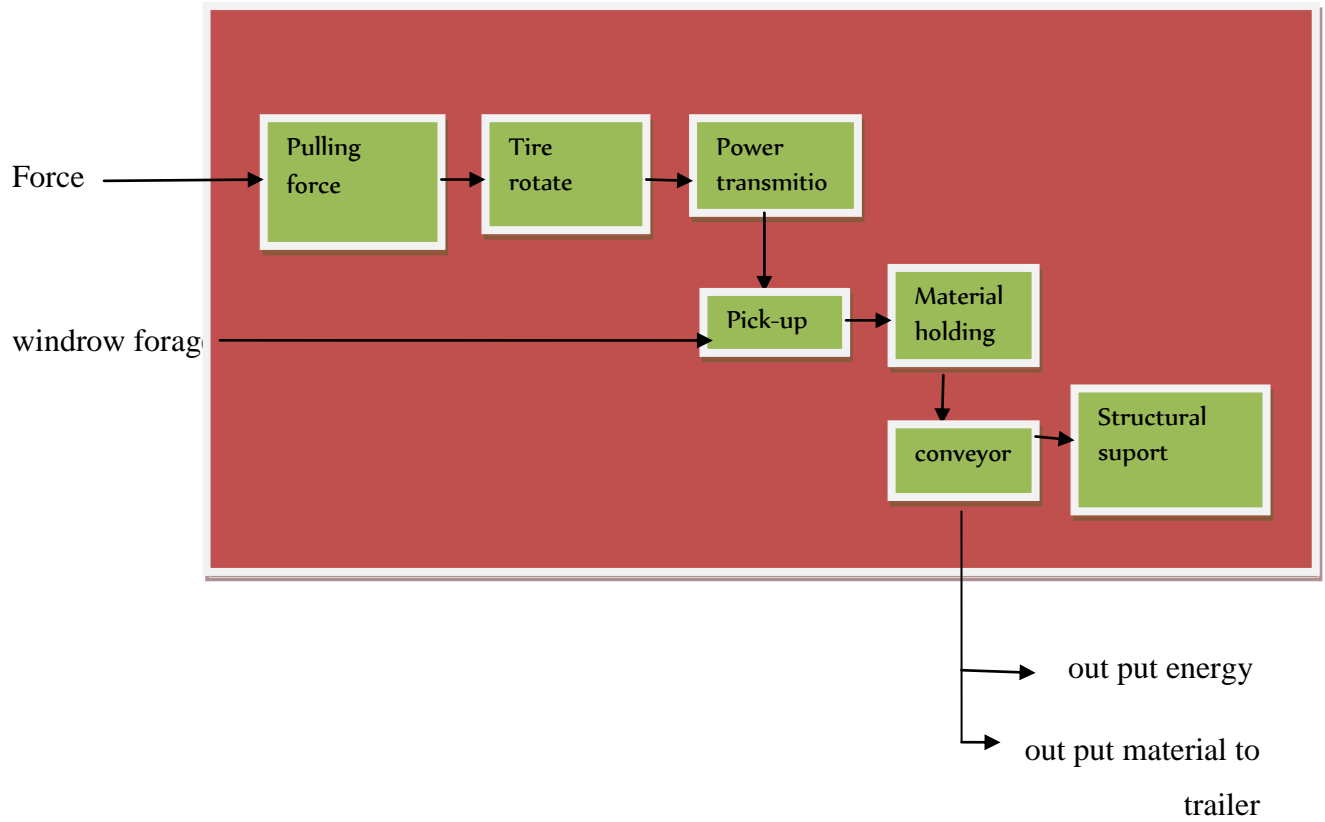

figure 3. 3 Over all function decomposition

3.5. Possible solution for sub- function

possible solution is used to select best option for every sub-function which come together and fulfill over all function.

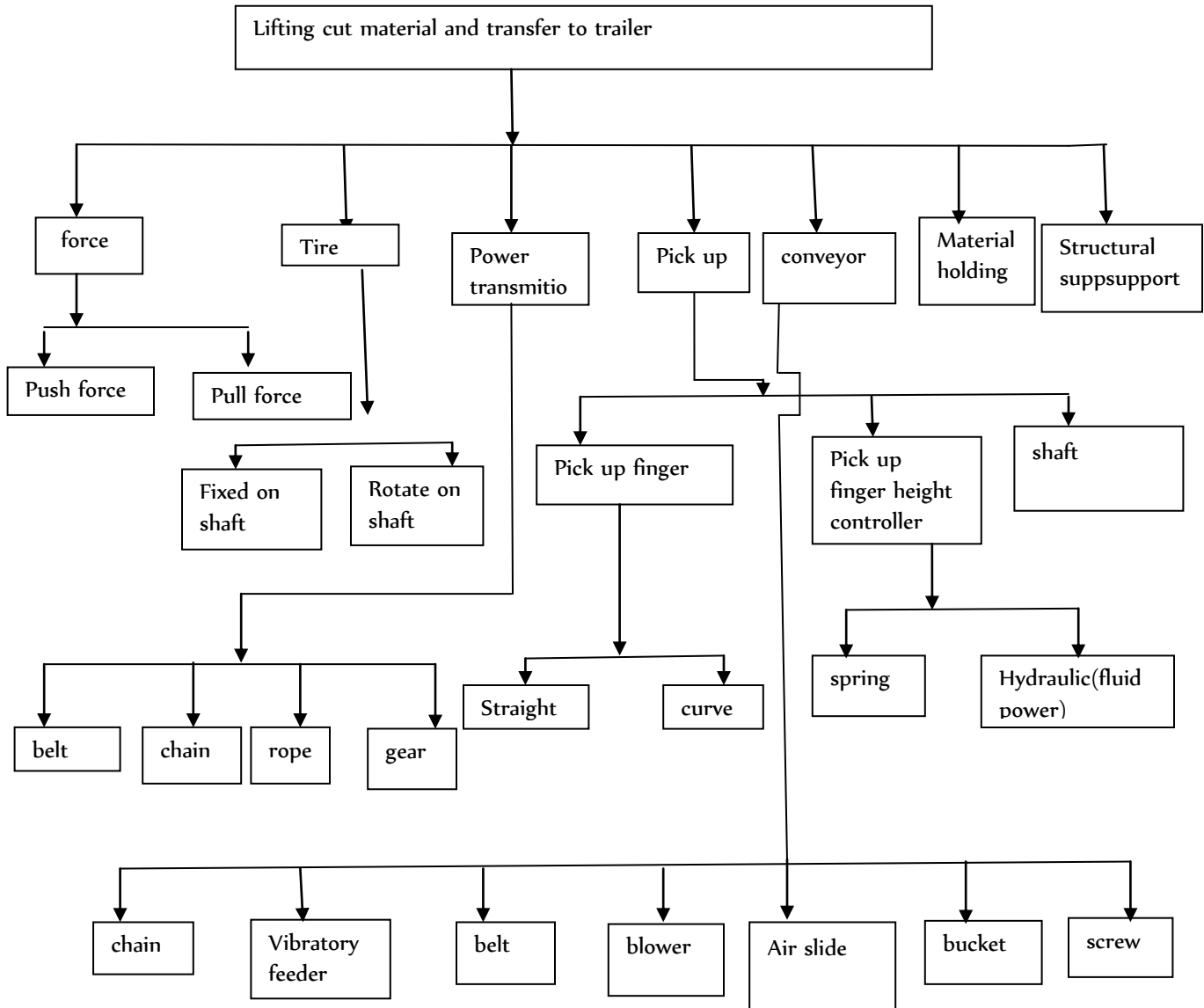

Figure 3. 4 Alternative tree for sub function

3.6. Analyzing and Evaluating The Product Alternatives(Concept Selection)

The product considered in this work, is analyzed, evaluated, ranked and selected through design aspects such as design for manufacturing, ergonomics, economic, function and safety. product attribute function is obtained from product attribute matrix. Indices for different product alternatives are calculated through product attribute function and they are ranked in descending order. The product with higher total weight value is selected as best one in the view of design aspects.

Selection of Force type

Force used to move the machine may be by pull or push system. During the pulling system the machine is attached to the source force at rear position. But for pushing system the machine is mounted at front. The following procedure takes place for selection:

+ List selection criteria

- a. flexibility:- ability it can be attached to many kinds of force source
- b. efficiency:- evaluation of the way it fulfills the objectives without material loss.
- c. Easy controlling to withdraw
- d. Manufacturing
- e. Cost

+ prepare selection matrix, rate, rank and select one or more concepts

Rating relative performance

- 1- Much worse than reference concept
- 2- Worse than reference concept.
- 3- Same as reference concept.
- 4- Better than reference concept.
- 5- Much better than reference concept

Rank orders the concepts with those concepts with more pluses and fewer minuses (for screening) are ranked higher and give high rank for the concept based on total score.

Table 3. 2 Attribute matrix of force option

Criteria	Weight	Concept			
		Pulling		Pushing	
		Rate	Weight score	Rate	Weight score
Flexibility	20	3	0.6	1	0.2
Efficiency	30	3	0.9	4	1.2
Easy controlling to windrow	20	3	0.6	4	0.8
Manufacturing	10	3	0.3	2	0.2
Cost	15	3	0.45	2	0.3
Total sum			2.85		2.7
Rank			1		2

Tire assemble

based on the way it can assembled with shaft, there is two obtion. The first case is make tire wheel fixed on the shaft and the shaft rotate. The second case may the wheel rotate on none movable shaft.

Selection criteria

- a. Complexity:- comparing the structural building needed to support the body of machine in both case
- b. Cost :- comparing the cost change due to addition of material like bearing(case 2), key(case 1), building structural support(case 2)
- c. Manufacturing
- d. Maintenance
- e. Availabilty on market

Table 3. 3: Attribute matrix for tire

Criteria	Concept				
	Weight	Tire wheel fixed on shaft (case one)		Tire wheel rotate on shaft (case2)	
		Rate	Weight score	Rate	Weight score
Complexity	35	3	1.05	5	1.75
Cost	20	3	0.75	4	0.8
Manufacturing	10	3	0.6	4	0.3
Maintenance	8	3	0.24	2	0.16
Availability on market	20	3	0.36	3	0.36
Total sum			3.0		3.37
Rank			2		1

Power transmission

Motion and power are transmitted from one machine to another. The most common are the rotary motion drives; this is attributable to the substantial advantages of uniform rotary motion over reciprocating motion. power transmitted from rotary wheel to pick up shaft. power is transmitted by gear, belt, shaft, rope, and etc. How ever, the distance between rotary wheel and pick up shaft is not appropriate for gear transmittion system. The choice of a transmission depends upon the intended use of and requirements for a given drive. It is generally required that the transmission should (selection criteria)

- 1 Have adequate reliability
- 2 Service life.
- 3 Be simple in construction.
- 4 Have adequate compactness and be small in size.
- 5 Offer a little resistance to motion, especially when the prime mover is start
- 6 Exhibit adequate accuracy of motion transformation (kinematics accuracy)

- 7 Produce little noise in service.
- 8 Offer substantial resistance to vibration.
- 9 Be easy to control.

Table 3. 4: Attribute matrix for power transmission

Criteria	Weight	Concept					
		Belt		Chain		Rope	
		Rate	Weight score	Rate	Weight score	Rate	Weight score
1	10	3	0.3	4	0.4	3	0.3
2	15	3	0.45	4	0.6	4	0.6
3	20	3	0.6	1	0.2	2	0.4
4	12	3	0.36	2	0.24	3	0.36
5	10	3	0.3	4	0.4	3	0.3
6	8	3	0.24	4	0.32	3	0.24
7	6	3	0.18	1	0.06	3	0.18
8	4	3	0.12	1	0.04	2	0.08
9	15	3	0.45	2	0.3	3	0.45
Sum total			3.0		2.56		2.91
Rank			1		3		2

Pick up finger height controller

The ground of the grass with windrow may not fully flat surface or irregularity of the land flatness may take place. To solve this problem the mechanism which adjust the height of pick up finger necessary. It can be controlled by compressed or relaxed spring, hydraulic pressure and etc

Selection criteria:

- a. Efficiency

- b. Structural complexity
- c. Amount of height change
- d. Space compactability
- e. Simplicity of manufacture

Table 3. 5: Attribute matrix for pick up finger controlling mechanism

Criteria	Weight	Concept			
		Spring		Hydraulic	
		Rate	Weight score	Rate	Weight score
Amount of height change	12	3	0.36	4	0.48
Space compactability	25	3	0.75	2	0.5
Simplicity of manufacture	20	3	0.6	1	0.2
Efficiency	20	3	0.6	4	0.8
Structural complexity	10	3	0.3	2	0.2
Cost	8	3	0.24	2	0.16
Sum total			2.85		2.34
Rank			1		2

Pick up finger

Pick up raod is used to pick up the grass from ground to grass holding part. The number of pick up and its shape may effects amount loss of material. Two obtion : straight road and curve

Selection criteria:

- a. Manufacturing simplicity
- b. Efficiency during pick up
- c. Efficiency during transfer
- d. Suitablity with height controller

- e. Resistance of impact force
- f. Assembling simplicity
- g. Cost

Table 3. 6: Attribute matrix for pick up finger shape

Criteria	Weight	Concept			
		Straight road		Curve	
		Rate	Weight score	Rate	Weight score
Manufacturing simplicity	12	3	0.36	2	0.24
Efficiency during pick up	25	3	0.75	4	1
Efficiency during transfer	20	3	0.6	2	0.4
Suitability with height controller	15	3	0.45	2	0.3
Resistance of impact force	12	3	0.36	4	0.48
Assembling simplicity	10	3	0.3	2	0.2
Cost	6	3	0.18	2	0.12
Total sum			3		2.74
Rank			1		2

Conveyors

These are gravity or powered equipment commonly used for moving bulk or unit load continuously or intermittently, uni-directionally from one point to another over fixed path, where the primary function is conveying of the material by the help of movement of some parts or components of the equipment. The major sub classifications and some of the common individual equipment under these sub-classifications are mentioned in the following lists:

- a. Belt conveyor:- flat belt, trough belt, closed belt, metallic belt, portable belt, telescoping belt
- b. Haulage conveyor:- a special class of chain conveyor in which load is pushed or pulled and weight is carried by stationary troughs, surface or rail. It includes drag chain, flight, meta, tow.
- c. Chain conveyor:- apron or pan, slat, cross bar or arm, car type or pallet, en-mass, carrier chain and flat top, trolley, power and free, suspended tray or swing tray
- d. Cable conveyor
- e. Bucket conveyor:- gravity discharge, pivoted bucket, bucket elevator
- f. Roller conveyor:- gravity, powered or driven, portable
- g. Screw conveyor
- h. Pneumatic conveyor
- i. Hydraulic conveyor

Selection criteria

- A. Effectiveness for material to be conveyed.
- B. Conditional effect like moisture
- C. Flexibility
- D. From what is being moved
- E. To what the product moved
- F. How far will it travel vertically or inclined?
- G. At what rate is the material being moved ?
- H. How often / for how long will the conveyor operate each day?
- I. Will the conveyor operate in a dusty or otherwise hazardous area (i.e. will nema-rated explosion-proof motors and other such equipment be required)?
- J. Will the conveyor be readily accessible for maintenance?
- K. How long is the conveyor expected to run between services?
- L. Energy consumption
- M. Cost
- N. Construction simplicity

Step one – concept screening

Table 3. 7: Attribute matrix for concept screening of conveyor selection

Criteria	Concept						
	Belt	Chain	Bucket	pneumatic	Roller	Screw	Rope
A	0	0	-	-	-	-	0
B	0	0	+	-	0	-	0
C	0	-	-	+	-	-	0
D	0	0	+	+	-	+	0
E	0	0	0	0	-	0	0
F	0	0	+	+	-	+	0
G	0	-	-	-	-	-	0
H	0	+	+	+	+	+	0
I	0	-	-	-	-	+	+
J	0	-	-	-	+	-	+
K	0	-	-	+	-	-	+
L	0	0	0	-	+	0	+
M	0	-	-	-	+	-	+
N	0	-	0	-	-	+	+
Sum of +’s	0	2	4	5	4	5	6
Sum of – ‘s	0	6	7	8	9	7	0
Sum of 0’s	14	6	3	1	1	2	8
Net score	0	-4	-3	--3	-5	-2	6
Rank	2	6	4	5	7	3	1
Continue?	Yes	No	Yes	Yes	No	Yes	Yes

Step two – concept scoring

- A. effectiveness for material to be convey.
- B. Flecibility
- C. From what is being moved
- D. To what the product moved
- E. How far will it travel vertically or iclinded?
- F. At what rate is the material being moved ?
- G. Will the conveyor be readily accessible for maintenance?
- H. How long is the conveyor expected to run between services?
- I. Cost
- J. Costruction sinplicity

Table 3. 8: Attribute matrix for scoring of conveyor selection

Criteria	Wei ght	Concept									
		Belt		Pneumatic		Bucket		Rope		Screw	
		Rate	Weight score	Rate	Weight score	Rat e	Weight score	Rat e	Weight score	rate	Weight score
A	17	3	0.51	1	0.17	5	0.85	3	0.51	2	0.34
B	5	3	0.15	4	0.2	2	0.1	3	0.15	2	0.1
C	15	3	0.45	4	0.6	4	0.6	3	0.45	1	0.15
D	6	3	0.18	4	0.24	3	0.18	3	0.18	1	0.06
E	10	3	0.3	5	0.5	5	0.5	3	0.3	3	0.3
F	8	3	0.24	1	0.24	2	0.16	4	0.32	2	0.16
G	9	3	0.27	2	0.18	2	0.18	4	0.36	2	0.18
H	5	3	0.15	4	0.2	5	0.25	4	0.2	5	0.25
I	12	3	0.36	2	0.24	2	0.24	3	0.36	2	0.24
J	13	3	0.39	2	0.26	2	0.26	2	0.26	2	0.26
Total sum			3.0		2.83		3.32		3.09		2.04
Rank			3		4		1		2		5

3.7. Alternative Evaluation Tree Summary

After analysis alternative evaluation the best alternatives are selected. Figure below show are the first option selected alternatives.

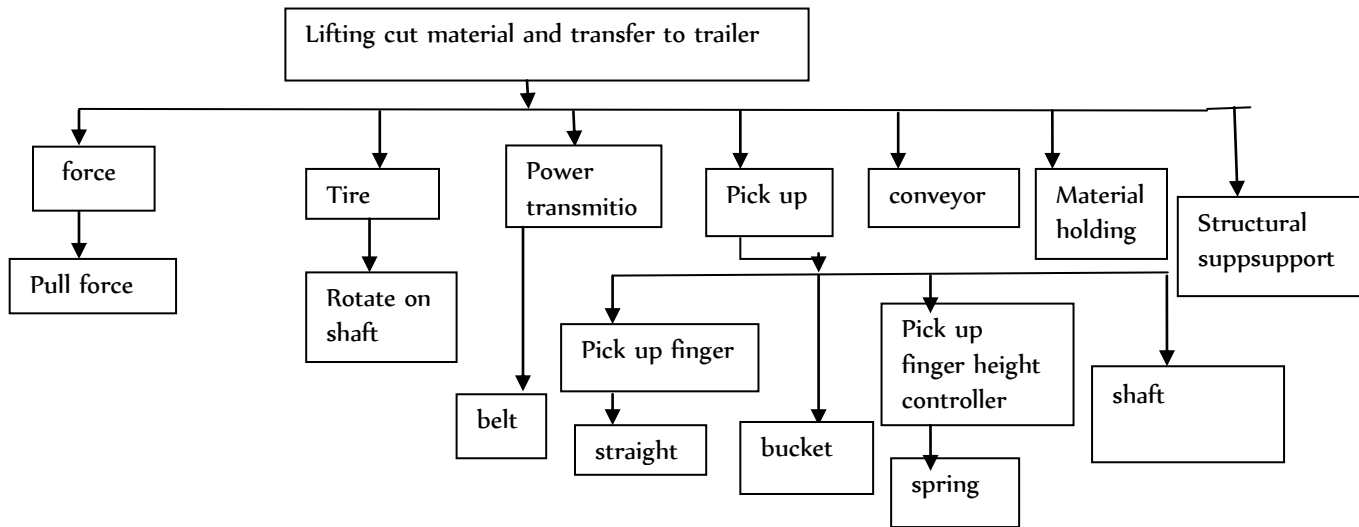

Figure 3. 5 Result from Alternative tree evaluation

Chapter Four: Mathematical Relation

4.1. Forward Motion

The forward speed of machine depends on the speed of pulling or pushing body. Let forward speed represent by 'v' and diameter of tire is d. the angular speed (ω) of tire analyzed as follows:

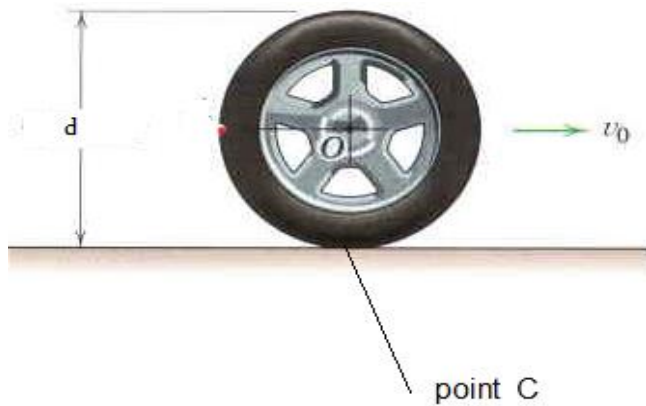

Figure 4.1 Representation tire motion

$V_o = V_c + V_{o/c}$, at contacting time the velocity at point 'C' becomes zero.

$$V_o = V_{o/c} = d/2 * \omega = V \dots \dots \dots \text{eq 4.1}$$

Note , V_o is the horizontal speed at the center of tire which the same with the forward speed v of machine.

4.2. Power Transmission

The crossed or twist belt drive, as shown in fig 4.2 is used with shafts arranged parallel and rotating in the opposite directions to make effectives pick up by reduce grass loss. In this case, the driver pulls the belt from one side (*i.e. RQ*) and delivers it to the other side (*i.e. LM*). Thus, the tension in the belt *RQ* will be more than that in the belt *LM*.

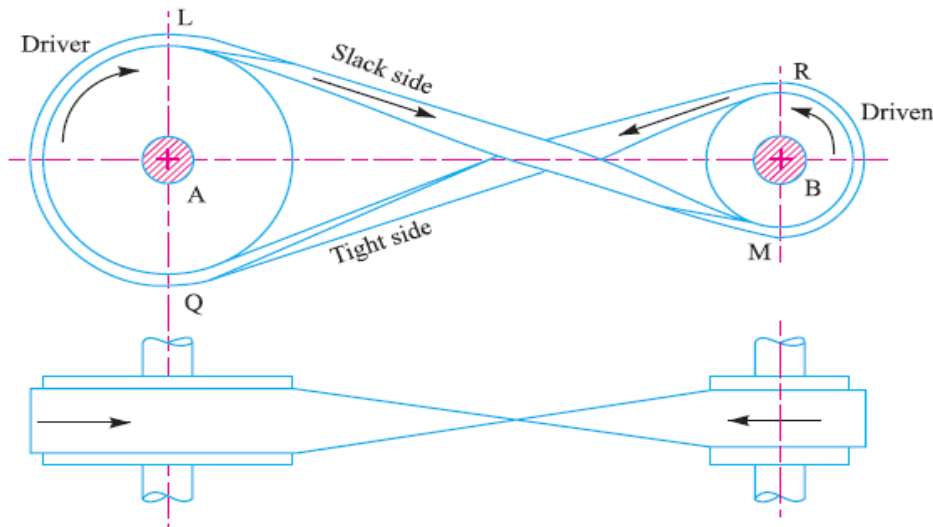

Figure 4.2 Representation of power transmission of belt with shaft

Speed of any point on the belt is constant. Its equal to the tangential speed of pulley. let tangential speed represented by V_t

$$V_t = \omega \cdot d/2 \text{ where } d - \text{diameter of pulley and } \omega - \text{angular speed of pulley}$$

Since the tangential speed on pulleys one and two are equal:

$$\omega_1 \cdot d_1/2 = \omega_2 \cdot d_2/2 \text{ where } \omega_1 \text{ and } \omega_2 \text{ angular speed of driver and driven pulley and } d_1 \text{ and } d_2 \text{ diameter of driver and driven pulleys respectively}$$

$$\omega_1 / \omega_2 = d_2 / d_1 \text{eq 4.2}$$

Power produced due to the difference tension occurred on the both side. As we know, power is the product of force and velocity.

$$p = v(T_2 - T_1) \quad \text{but } v = \omega_1 \cdot \frac{d_1}{2} = \frac{d_2}{2} \cdot \omega_2$$

$$p = \omega_2 \cdot d/2(T_2 - T_1)$$

$$= \omega_2 \cdot T' \text{eq 4.3}$$

where $T' = d/2 \cdot (T_2 - T_1)$ is the torque produced due to tangential force.

Maximum Tension In The Belt

A little consideration will show that the maximum tension in the belt (T) is equal to the total tension in the tight side of the belt (T_1).

Let σ_{\max} = Maximum safe stress, b = Width of the belt, and t = Thickness of the belt.

The maximum tension in the belt(T) = Maximum stress \times Cross-sectional area of belt

$$= \sigma_{\max} \cdot b \cdot t \text{4.4}$$

Contact angle(θ):

Contact angle is equal for both pulley when crossed belt system used.

$\theta_1 = \theta_2 = \theta = \pi + 2\alpha$ where θ_1 and θ_2 are contact angle of belt with driver and driven pulley respectively.

Total length (L):

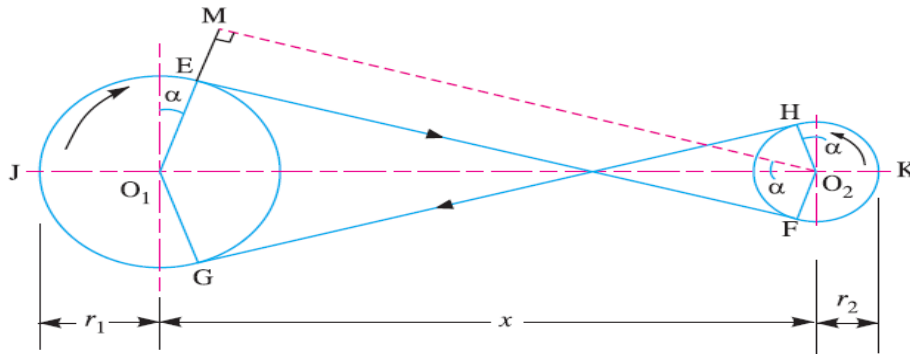

$$L = \text{Arc } GJE + EF + \text{Arc } FKH + HG = 2 (\text{Arc } JE + FE + \text{Arc } FK) \dots\dots\dots\text{eq 4.5}$$

$$\sin \alpha = \frac{O_2 M}{O_1 O_2} = \frac{d_1 + d_2}{2c} \quad \text{Arc } FK = d_2/4 (\pi + 2\alpha)$$

$$EF = O_2 M = \sqrt{C^2 - \left(\frac{d_1 + d_2}{2}\right)^2} \quad JE = d_1/4 (\pi + 2\alpha)$$

Friction on Curve Surface(Between on Pulley Surface and Belt)

Coulombs law states that the friction force is directly proportional to the normal force and the constant of proportionality is the coefficient of friction(μ)

$$F_f = \mu * R \quad \text{where R is normal force}$$

Tension force increase from value slack side with angle of contact of rope with pulley surface. As a rope bends over a small segment of a drum, the tension in a rope will increase from T in slack side to T+dT in an angle d θ .

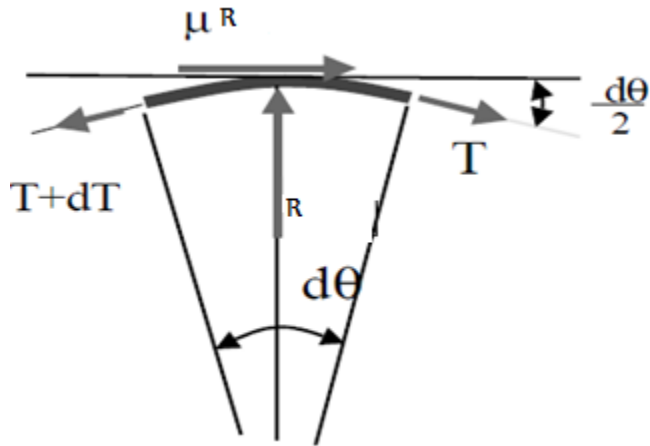

From above free body diagram:

Summation force in tangential force must be zero for static condition.

$$(T + dT) \cos(d\theta/2) - T \cos(d\theta/2) - F_f = 0$$

$$dT \cdot \cos(d\theta/2) - F_f = 0$$

$$dT \cdot \cos(d\theta/2) = F_f ,$$

For small $d\theta/2$, $\cos d\theta/2 = 1$ then $F_f = dT$ 1

Summation of force in normal direction must be zero

$$R' - T \sin(d\theta/2) - (T + dT) \sin(d\theta/2) = 0,$$

$$R' = (2T + dT) \sin(d\theta/2) , \text{ for small } d\theta/2, \sin(d\theta/2) \sim d\theta/2$$

then, $R' = (2T + dT) d\theta/2$

But friction force (F_f) is

$$F_f = \mu \cdot R' = \mu \cdot (2T + dT) (d\theta/2) \quad \text{substitute } F_f \text{ in equation 1}$$

then $F_f = dT = \mu \cdot (2T + dT) (d\theta/2)$, let ignore $dT \cdot d\theta/2$ since its very small

$$\frac{dT}{T} = \mu \cdot d\theta$$

Make integration in both side $\int_{T_1}^{T_2} \frac{dT}{T} = \mu \int_0^\theta d\theta$

$$\ln \frac{T_2}{T_1} = \mu * \theta \dots\dots\dots \text{eq 4.6}$$

from $F_f = \mu * R' = \mu * (2T + dT) \sin(d\theta/2)$ equation show friction force depends on:

- ✓ the total angle of contact
- ✓ the coefficient of friction
- ✓ the tension in the rope

4.3. Angular Motion on Pick up Finger

Angular motion of the pick up finger depends on diameter of pulley on pick up shaft.

This means based on the diameter of pulley on pick up shaft and tire, the speed can be increase or decrease. To increase the efficiency of pick up hay (grass) by minimise lose make an angular velocity of pick up shaft to be high. This means, for rotating S' circumference distance between consecutive pick up finger, the forward distance of machine approach to be small when compare with S'.

Forward velocity of a machine is the time rate of distance covered

$$V_o = S / t \text{ where } S \text{ and } t \text{ are distance moved and time taken respectively}$$

$$t = S/V_o \dots\dots\dots \text{i}$$

let relate angular velocity with the distance

$$\omega^2 = \theta/t \text{ but } \theta \text{ is the angle between consecutive pick up finger in radian}$$

$$t = \frac{\theta}{\omega^2} \dots\dots\dots \text{ii}$$

from equation i and ii

$$S = \frac{\theta * V_o}{\omega^2} \dots\dots\dots \text{3}$$

for $\theta = 60^\circ = 1.05$ and from specification $V_o = 1 \text{ m/s}$

$$S = \frac{1.05}{\omega^2} \text{ m, } \omega^2 \text{ in rad/sec} \dots\dots\dots \text{eq. 4.7}$$

This distance used to know the gap between consecutive pick up finger to make vertical (perpendicular) to the ground. To increase the efficiency of pick-up the hay without lose, decreasing S distance as much as possible. we have the following option:

✚ by increasing ω^2 or

✚ by selecting minimum d_2

Velocity, acceleration and force at tip of pick up finger

i. Velocity at tip of pick up finger

$$\mathbf{V}_c = \mathbf{V}_O + \mathbf{V}_{c/o} \quad \text{in vector quantity}$$

$$\mathbf{V}_c = \mathbf{V}_O + \boldsymbol{\omega} \times \mathbf{R}$$

$$\mathbf{V}_c = \mathbf{V}_O + \boldsymbol{\omega} \times (R \cos \alpha \mathbf{i} + R \sin \alpha \mathbf{j})$$

where

- $\boldsymbol{\omega}$ is the angular motion of pick shaft in clockwise direction
- R is radius from center of pick up shaft to tip of pick up finger
- α the angle between consecutive pick up finger
- V_c is tangential velocity at tip of pick up finger
- $V_{c/o}$ is velocity of C with respect to O

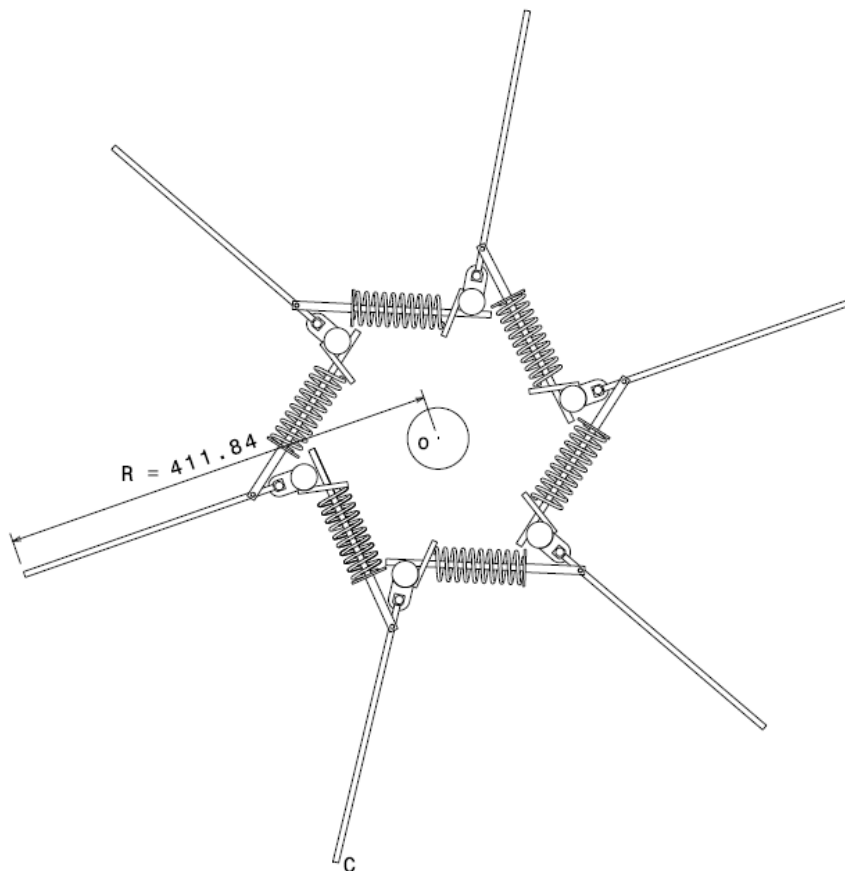

Figure 4. 3 Geometric description of pick up finger

Acceleration at tip of pick up finger(a_c)

$$\begin{aligned} \mathbf{a}_c &= \mathbf{a}_o + \mathbf{a}_{c/o} \quad \text{where } \mathbf{a}_o \text{ is the acceleration at center of pick up shaft} \\ &= \mathbf{a}_o + (\mathbf{a}_{c/o})_t + (\mathbf{a}_{c/o})_n \end{aligned}$$

where subscript 't' and 'n' indicate tangential and normal direction.

But $(\mathbf{a}_{c/o})_n = \omega^2 \times (\omega^2 \times \mathbf{R})$

$$(\mathbf{a}_{c/o})_t = \alpha \times \mathbf{R}$$

α is the angular acceleration which occur during the angular velocity vary(not constant).

For constant forward speed of a machine, means external pulling force apply on the machine if it is constant, $a_o = 0$, $(a_{c/o})_t = 0$, $\omega^2 = \text{constant}$. Therefore:

$$a_c = (a_{c/o})_n = \omega^2 \times (\omega^2 \times \mathbf{R}) \dots \dots \text{its normal acceleration which only}$$

produce normal force.

Power transmitted depends on the weight of hay, tangential force (F_{tc}) and impact force apply on the pick up finger due to non uniformity of land surface. Therefore, power(P) is

$$P = V * F_t, \text{ where } V \text{ is tangential velocity}$$

F_t is total tangential force

$F_t = F_{tc} + nF_{\text{impact}} + F_{\text{weight}}$, where n is number of pick up finger may touch ground at the same time and F_{tc} is force produced due to acceleration but tangential acceleration is zero when angular velocity and V_o are constant. Let ignore F_{weight} because its effect small and both F_{impact} and F_{weight} are not make effect in same time. during F_{impact} applied on the pick up finger, the material can't transferred and when $F_{\text{impact}} = 0$, means ground surface not contact pickup finger, pick up finger can transfer material but F_{weight} much less than F_{impact} . therefore we can take F_{impact} to calculate power. therefore $F_t = n F_{\text{impact}} = 60 * 10 \text{ N} = 600 \text{ N}$ and $P = 600 * V$ watt when V in m/s

4.4. Helical Springs

The helical springs are made up of a wire coiled in the form of a helix and is primarily intended for compressive or tensile loads.

common terms

1. Solid Length: Solid length of the spring(L_s) is

$$L_s = n'.d \quad \text{where } n' = \text{Total number of coils, and } d = \text{Diameter of the wire.}$$

2.Free Length(Lf):

$$L_f = n'.d + \delta_{max} + 0.15\delta_{max}$$

Where δ_{max} = maximum deflection

3. Spring Index(C'): $C' = D / d$ where D = Mean diameter of the coil, and d = Diameter of the wire.

❖ The spring mostly used in machinery have spring index above 3.

4. Spring rate(k): $k = W / \delta$ where W = Load, and δ = Deflection of the spring.

5. Pitch(p'): $p = \frac{L_f}{n'-1}$ or $\frac{L_f - L_s}{n'}$ + d

Stress Analysis (Design of Spring)

Stress applied on spring are torsion shear stress, direct shear stress. Then, maximum stress applied on spring may get by their sum.

❖ Torsion shear stress = $\frac{T_{tor} * d}{2J}$

where $T_{tor} = F * D/2$ is torsion created in the coil

$J = \frac{\pi}{32} * d^4$ is polar moment of energy

❖ Direct shear stress = $\frac{F}{A}$

Total shear stress applied on spring (τ) = $\frac{T*d}{2J} + \frac{F}{A}$, but $A = \frac{\pi*d^2}{4}$

Then, after substituting the A,T,J value and arrange total shear stress (τ) becomes

$$\tau = ks \frac{8 F D}{\pi d^3} = \frac{8 F (C+0.5)}{\pi d^2} \dots\dots\dots 4.8, \text{ where } ks = \frac{2c+1}{2c}, \text{ c is spring index}$$

Deflection of Helical Springs

The deflection-force relations are quite easily obtained by using Castigliano’s theorem. The total strain energy for a helical spring is composed of a torsion component and a shear component is

$$U = \frac{T^2 L}{2 G J} + \frac{F^2 L}{2 A G} = \frac{4 F^2 D^3 n'}{d^4 G} + \frac{2 F^2 D n'}{d^2 G}$$

then deflection (δ)

$$\delta = \frac{\partial U}{\partial F} = \frac{8 F D^3 n'}{d^4 G} + \frac{4 F D n'}{d^2 G} = \frac{4 * F * n}{d * G} (2 C^3 + C) \dots\dots\dots 4.9$$

Chapter Five: Embodiment Design

5.1. Introduction

During the embodiment phase the designers must determine the overall layout design (general arrangement and spatial compatibility), the preliminary form designs (component shapes and materials) and the production processes, and provide solutions for any auxiliary functions. During all of this, technological and economic considerations are of paramount importance.

5.2. Design component for Power Transmission (from tire wheel to pick up head shaft)

As described in task specification the rotation of pickup shaft must be in counter clockwise. Therefore the rotation of both pulleys on the tire and pick up shaft are in opposite direction and must used cross or twist belt.

5.2.1. Selection of belt

Select Pulley Diameter

To get high efficiency of pick up the grass' let select minimum standard diameter of driven pulley (d_2) aim to get high angular speed(ω_2) and d_1 (diameter of drive pulley) $< 78\text{cm}$ to make clearance from ground. Then, select $d_1 = 56\text{cm}$ and $d_2 = 35.5\text{ cm}$

Velocity of Pulley

From eq. 4.1 we can get the angular speed of tire (ω_1) which has the same angular velocity with drive pulley attach on tire wheel. This means, $\omega_1 = 2 V_0 / d_1 = 3.6\text{rad/sec}$ where $V_0 = 1\text{ m/s}$ and $d_1 = 0.5588\text{ m}$.

Velocity of belt (V_b): which equal to tangential velocity of drive pulley

$$= \omega_1 * d_1 / 2 = 1.0\text{ m/s}$$

Angular velocity of driven pulley: $\omega_2 = 2 * V_b / d_2 = 5.6\text{ rad/sec} = 0.89\text{ rev/sec}$

Belt Total Length(L)

Substitute $C = 1\text{m}$, $d_1 = 0.5588\text{ m}$, $d_2 = 0.3556\text{ m}$ in equation 4.4 and we get $L = 3.65\text{ m}$

Contact Angle $\theta = 180 + 2 \alpha = 234.4^\circ = 4.1\text{ rad}$ where $\alpha = 27.2^\circ$

Belt Tension

Maximum power of belt transmit must be greater than power need to rotate pick up shaft during application due to power loss by friction. Then assume $P = 7 \text{ kW}$ (greater than 6912 watt which power need for application). Let find tension of belt in tight side(T_2) and slack side(T_1) from equation 3.3 and eq.3.5. In put values: $P = 7 \text{ kw}$, $V_b = 2.016 \text{ m/s}$, $\theta = 4.1 \text{ rad}$ and $\mu = 0.2$ cotton belts which mostly used in farm machinery.

Then $T_1 = 2.904 \text{ kN}$ and $T_2 = 6.374 \text{ kN}$

Belt Width(b)

The maximum tension in the belt(T) = Maximum stress \times Cross-sectional area of belt

$$= \sigma_{\max} * b * t \quad \text{but } \sigma_{\max} = \sigma_{\text{ult}} / \text{f.s}$$

Take belt thickness(t) = 6.5 mm and $\sigma_{\text{ult}} = 35 \text{ Mpa}$, factor of safety(f.s) = 2 and $T = 6.374 \text{ kN}$

Then, belt width (b) = 56 mm. Therefore , from standard $b = 63 \text{ mm}$ can be select.

5.2.2. pulley dimension

The pulleys are generally made of cast iron, because of their low cost. The rim is held in place by web from the central boss or by arms or spokes. The arms may be straight or curved and the cross-section is usually elliptical. The cast iron pulleys are generally made with rounded rims. This slight convexity is known as crowning. The crowning tends to keep the belt in centre on a pulley rim while in motion.

The following procedure may be adopted for the design of cast iron pulleys.

➤ *Dimensions of pulley*

width of pulley: width of the pulley or face of the pulley (B) is taken 25% greater than the width of belt. Then, $B = 1.25 b = 78.75 \text{ mm}$; where b = Width of belt and from standard select widths flat cast iron pulley is 80mm.

The thickness of the pulley rim (t) : varies from $\frac{D}{300} + 2 \text{ mm}$ to $\frac{D}{200} + 3 \text{ mm}$ for single belt.

$$t = 3.87 \text{ to } 5.8 \text{ mm for drive pulley (D = 560 mm)}$$

$$t = 3.183 \text{ to } 4.78 \text{ mm for driven pulley (D = 355 mm)}$$

➤ *Dimensions of arms*

- i. The number of arms taken as 4 since for pulley diameter from 200 mm to 600 mm

ii. The cross-section of the arms:- is usually elliptical with major axis (a_1) equal to twice the minor axis (b_1). The cross-section of the arm is obtained by considering the arm as cantilever *i.e.* fixed at the hub end and carrying a concentrated load at the rim end. The length of the cantilever is taken equal to the radius of the pulley. It is further assumed that at any given time, the power is transmitted from the hub to the rim or *vice versa*, through only half the total number of arms.

✓ Tangential load per arm (F_t) = $\frac{T}{R \cdot n/2} = 1.67 \text{ kN}$

where $T_2 = P / \omega_2 = 1.25 \text{ kNm}$ is torque on driven pulley, $T_1 = P / \omega_1 = 1.94 \text{ kNm}$, $R_2 = 177.5 \text{ mm}$ is radius of pulley, $R_1 = 280 \text{ mm}$ is radius of drive pulley and $n = 4$ is number of arms.

✓ Maximum bending moment on the arm at the hub end (M) = $F_t \times R = 625 \text{ Nm}$

(M) = $F_t \times R_2 = 296.4 \text{ Nm}$ for driven pulley

$M = F_t \times R_1 = 497.6 \text{ Nm}$ for drive pulley

✓ section modulus (Z) = $\frac{\pi}{32} \times b_1 \times a_1^2$ but $a_1 = 2b_1$, from stress analysis cross section area can be obtain.

bending stress ($\sigma_{b \text{ allowable}}$) = $\frac{M}{Z}$, $\sigma_{b \text{ allowable}}$ = the yield bending stress of cast iron (150 Mpa) divide for factor of safety (1.5) = 100 Mpa. Therefore, ($\sigma_{b \text{ allowable}}$) = $\frac{M}{Z} = \frac{64 \cdot M}{\pi \times a_1^3}$, substitute $M = 296.4$ for driven pulley and $M = 497.6 \text{ Nm}$ for drive pulley.

Then, $a_1 = 39 \text{ mm}$ and $b_1 = 19.5 \text{ mm}$ at hub joint for driven pulley.

$a_1 = 47 \text{ mm}$ and $b_1 = 23.5 \text{ mm}$ at hub joint for drive pulley.

iii. The arms are tapered from hub to rim. The taper is usually 1/48 to 1/32 ratio.

➤ **Dimensions of hub**

(i) The diameter of the hub (d_1) in terms of shaft diameter (d) may be fixed by the following relation :

$d_1 = 1.5 d + 25 \text{ mm} = 107.5 \text{ mm}$, let say 108 mm

(ii) The length of the hub (L) = $\frac{\pi}{2} * d = 86.4 \text{ mm}$

[R.S. KHURMI, J.K. GUPTA]

Note: Selection of pulley must be based on the dimension of pulley analyzed above.

5.2.3. Shaft Diameter

Since shaft attach to wheel of tire (fixed), the diameter of shaft can obtain by considering as cantilever. Free body diagram as follows:

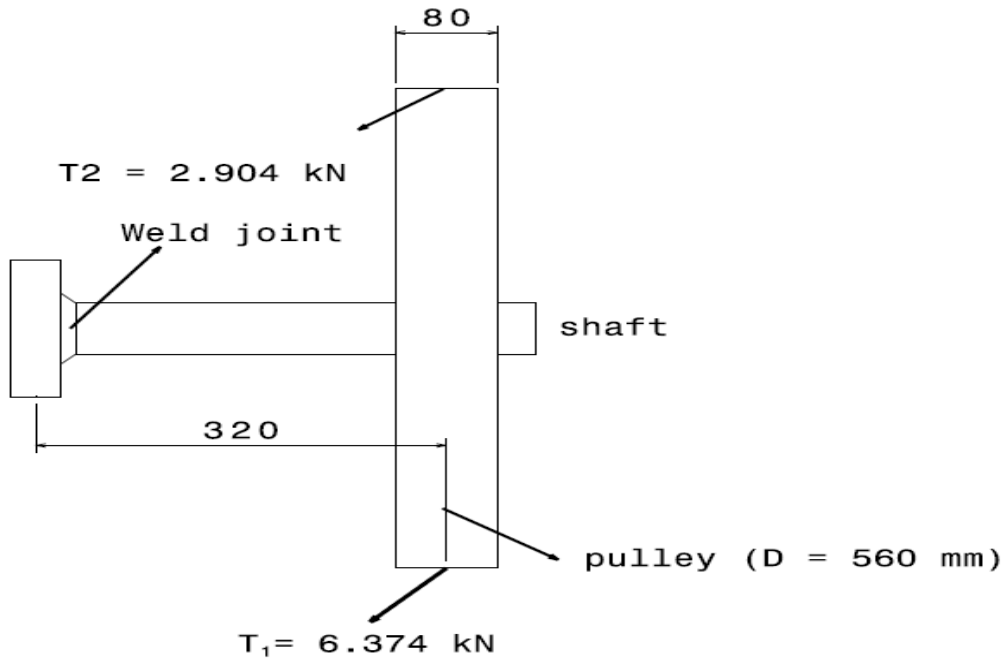

Figure 5. 1 Shaft attach to tire wheel

Note: Tangential force on pulley(F_t) is the sum of tight and slack tension (T_1+T_2)= 9.278 kN. Weight of pulley approximately 88.2 N in vertical down ward and neglect since its small when compare with force applied by belt tension which is 9.278 kN. Maximum moment is takes place at joint equal to $M = 9.278 \text{ kN} \times 0.29\text{m} = 2.69 \text{ kNm}$ and Torsion($T_{\text{tor}} = 1.94 \text{ kNm}$)

Stress analysis:

$$\sigma_b = \frac{1}{Z} \sqrt{M^2 + T^2} = \frac{32*}{\pi*d^3} \sqrt{M^2 + T^2} \quad \sigma_b - \text{allowable stress and } Z - \text{section modulus}$$

material selection: based on the availability in country mild steel selected. properties of mild steel : density 7861.093 kg/m^3 and maximum tensile strength: 500 Mpa (72500 psi), yield strength :250Mpa. Therefore, $\sigma_b = \text{yield strength}/ \text{factor of safety}$. let take factor of safety 1.5 and $\sigma_b = 166.67 \text{ Mpa}$. Then $d = 58.7 \text{ mm}$. Let say $d = 60 \text{ mm}$

Weld Design

Drive Pulley shaft has both torsion and bending stress . They are difficult to determine because of the variable and unpredictable parameter like homogeneity of the weld metal, thermal stresses

in weld, change in physical properties due to high rate of cooling. The stresses are obtained on the following assumptions:

- 1- The load is distributed uniformly along the entire length of the weld.
- 2- Stress is spread uniformly over its effective section.

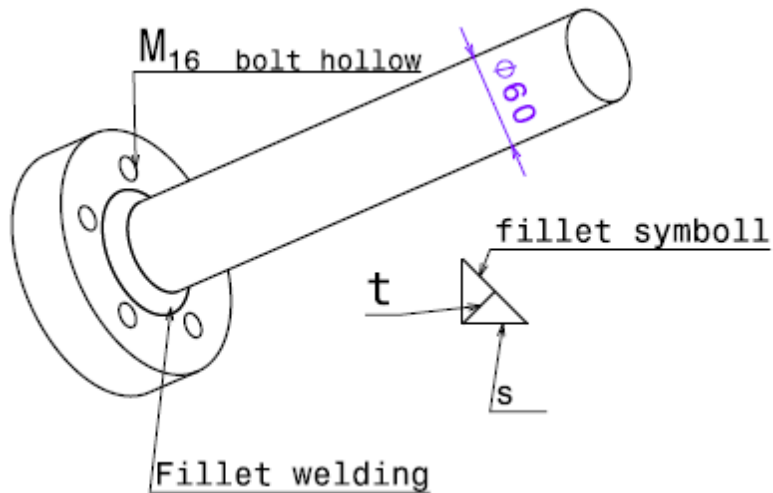

Figure 5. 2 Description of weld area for shaft attach to tire wheel

- Circular fillet weld subjected to torsion.

$$\text{Shear stress } \tau = \frac{Tr}{J} = \frac{T \frac{d}{2}}{\frac{\pi d^3 t}{4}} = \frac{2T}{\pi d^2 t} \quad J = \frac{\pi d^3 t}{4} \quad t = 0.707s$$

Maximum shear stress on the throat at 45° to horizontal plane.

$$\tau = \frac{2T}{0.707s \pi d^2} = \frac{2.83T}{s \pi d^2}$$

- Circular filled subjected to bending moment.

$$\sigma = \frac{M}{Z} = \frac{4M}{\pi d^2 t} = \frac{4M}{\pi d^2 (0.707s)} = \frac{5.66M}{\pi d^2 s}$$

Bending occur in an horizontal plane along the leg of the fillet weld. Maximum bending occurs at the throat of the weld at 45° to the horizontal plane .

Since the shaft has both stress, the weld length can be calculate as follows:

For Fillet weld type and Coated electrode ($\tau=98$ Mpa from index A-2) with factor of safety 1.5.

$$\begin{aligned} \text{Maximum shear stress } \tau_{\max} &= \frac{98}{1.5} \text{ Mpa} = \frac{1}{2} \sqrt{\sigma_b^2 + 4\tau^2} \\ &= \frac{1}{2 \cdot \pi \cdot S \cdot d^2} \sqrt{(5.66 M)^2 + (2.83 tT)^2} \end{aligned}$$

Therefore $s = 11$ mm , where $M = 2.69$ kNm, $T = 1.94$ kNm and $d = 60$ mm.

key Design

Keys are used to enable the transmission of torque from the shaft to pulley. The gib-head key which acts to prevent relative axial motion rather than use other mechanism to fixed pulley on shaft.

The usual proportions of the gib head key are : Width, $w = d / 4$ and thickness at large end $t = 2w / 3 = d / 6$ according to IS : 2292 and 2293-1974 (Reaffirmed 1992) standard $w = 20$ mm and $t = 12$ mm for shaft diameter 58mm to 65 mm.

Let find key length:

- Considering shearing of the key, the tangential shearing force (F) acting at the circumference of the shaft

$$F = \text{Area resisting shearing} \times \text{Shear stress} = 2 T_{\text{tor}}/d = l \times w \times \tau, \text{ for mild steel } \tau = 115 \text{ Mpa.}$$

where $T_{\text{tor}} = 1.94$ kNm is torque transmitted by shaft

$d = 60$ mm is shaft diameter

τ is shear stress of mild steel.

F.S.=2 is factor of safety

Then length of gib head key (l) is becomes 43 mm..... i

- Considering crushing of the key, the tangential crushing force acting at the circumference of the shaft,

$$F = \text{Area resisting crushing} \times \text{Crushing stress} = 2 T/d = l \cdot t/2 \cdot \sigma_c, \text{ where } \sigma_c = 250 \text{ Mpa}$$

Then l can be 94 mm. ii

From equation i and ii, $l = 94$ mm will be selected.

(R.S. KHURMI and J.K. GUPTA ,2005)

5.3. Design of Pick Up Part

5.3.1. Spring Selection

Geometric Analysis: The spring start compression when force applied on spring greater than 10 N (where 10N is approximation weight of the grass pick up at one time). Free body diagram for one pick up finger before and after compression of spring is as follows.

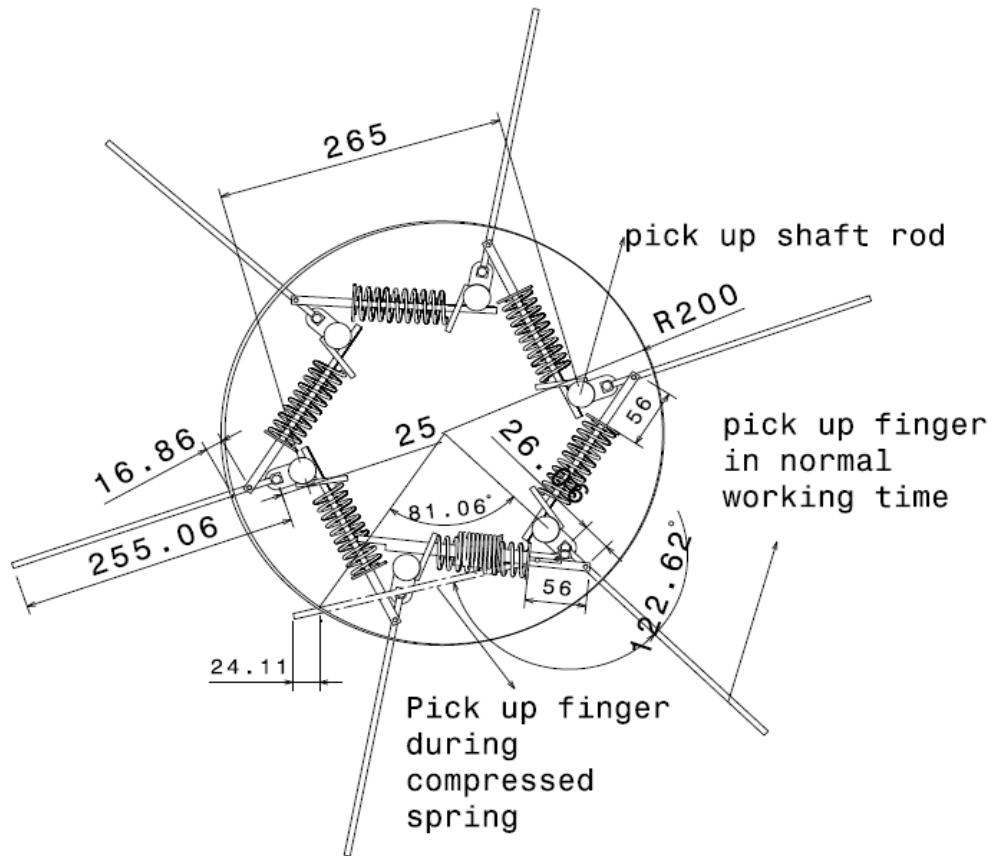

Figure 5. 3 Pick-up head component after and before compression

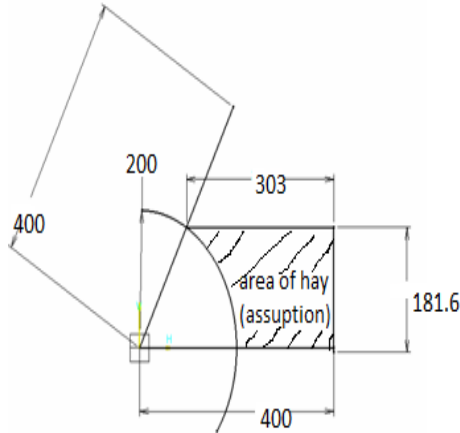

Figure 5. 4 Area of hay may pick up

Spring support rod and pick up finger are connect together by pin joint to make free rotation on pin axis. Slot need for montion pick up finger during compression along cylinder is

$$s = \frac{\pi * r * \theta}{180} = 265.3 \text{ mm, where } \theta = 76 \text{ in degree and } r = 200 \text{ mm is radius from center of shaft}$$

Deflection of spring (δ)= 42.683 mm, let say 45 mm

Force applied at tip of each pick up finger is 10 N and maximum deflection of spring $\delta = 4.5\text{cm}$.

Force at spring is calculated as follows

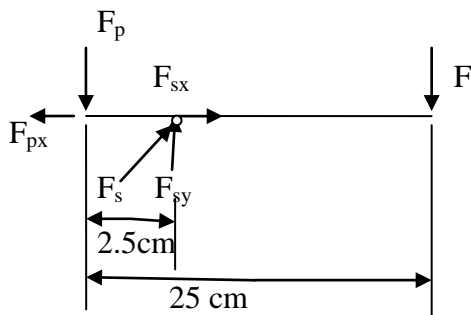

where F_p is force at pin

F_{sy} is force by spring perpendicular to pick up finger

F_{sx} is force by spring parallel to pick up finger

$F = 10\text{N}$ force at tip of pick up finger

Let find F_s and F_p

$$\sum M_{\text{at pin}} = 0, \text{ positive in counter clock wise}$$

$$F_{sy} * 2.5 \text{ cm} - F * 25 = 0, \text{ then } F_{sy} = 10 * 25 / 2.5 = 100\text{N and } F_p = 90 \text{ N}$$

Total force which make spring to be compress is (F_s) = $\frac{F_{sy}}{\sin \gamma} = 119.3 \text{ N}$ and $F_{sx} = F_s * \cos \gamma = 65.1 \text{ N}$,

where $\gamma = 56.94^\circ$.

Stress analysis(design of spring)

Material used for spring : are mostly made from oil-tempered carbon steel wires containing 0.60 to 0.70 percent carbon and 0.60 to 1.0 per cent manganese. Music wire is used for small springs.

Non-ferrous materials like phosphor bronze, beryllium copper, monel metal, brass etc., may be

used in special cases to increase fatigue resistance, temperature resistance and corrosion resistance. Since carbon steel wires mostly available on market it may be better. The allowable shear stress depends on the diameter of wire and service for which they are used *i.e.* severe service, average service or light service. Let assume diameter of wire less than 3.125mm properties of the material are: $E = 210 \text{ kN/mm}^2$ $\tau_{\text{allowable}} = 595 \text{ Mpa}$

$$G = 80 \text{ kN/M}^2$$

Let find the diameter of wire from maximum shear stress equation and take factor of safety 1.5 and spring index 10.

$$\tau = ks \frac{8FD}{\pi d^3} = \frac{8F(C+0.5)}{\pi d^2}$$
 after substitute $F = F_{sy} = 119.3 \text{ N}$, $C = 10$, $\tau = 595/1.5 = 396.67$

Mpa, then $d = 2.839 \text{ mm}$. The standard size of spring wire may be selected from standard wire gauge $d = \mathbf{2.946 \text{ mm}}$ and $D = C \times d = \mathbf{29.46 \text{ mm}}$

Number of active coil(n) : can be get from deflection equation

$$\delta = \frac{4 * F * n' (2C^3 + C)}{G * d}$$
 , substitute $F = 119.3 \text{ N}$, $C = 10$, $G = 80 \text{ kN/mm}^2$, $d = 2.946 \text{ mm}$,

$\delta = 45 \text{ mm}$, then we can get $n' = \mathbf{11}$

$$\text{Free length}(L_f) = n' * d + \delta + 0.15 * \delta$$
 , subatitute $\delta = 45 \text{ mm}$, $n' = 11$ and $d = 2.946 \text{ mm}$

$$= \mathbf{84.156 \text{ mm}}$$

$$\text{pitch}(p) = \frac{L_f}{n' - 1} = \mathbf{8.4156 \text{ mm}}$$

5.3.2. Design of Pick up Finger

Force applied on pick up finger produce bending. Free body diagram as follows:

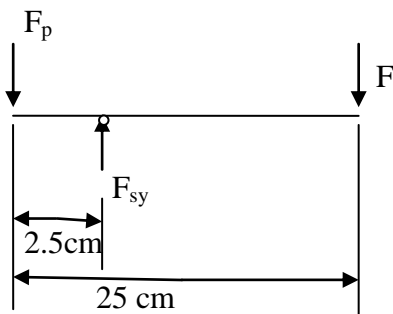

where F_p is force at pin

F_{sy} is force by spring perpendicular to pick up finger

$F = 10 \text{ N}$ force at tip of pick up finger

Result of reaction forces, $F_p = 90 \text{ N}$, $F_{sy} = 100 \text{ N}$, $F_{sx} = 65.1 \text{ N}$, are analyzed under spring design.

Maximum moment (M) = $10 \text{ N} \times 22.5 \text{ cm} = 2.25 \text{ N m}$.

Material : mild steel is selected let take factor of safety 2.5

Take pick up finger as square cross-section geometry and find the length side(a) based on the bending moment M and allowable bending stress of mild steel ($\sigma_b = 100 \text{ Mpa}$).

Then, $(\sigma_{b \text{ allowable}}) = \frac{M}{Z}$ where : $\frac{a^3}{6}$ and we get **a = 5.2 mm, let say 5.5 mm**

5.3.3. Design Pin

For pin connect shaft and pick up finger

Pin must resist force applied on it which is 90 N. Take pin length 30mm and force applied on pin gives shear stress. let find diameter of pin :

➤ material: mild steel selected. $\tau_{\text{all}} = 83.3 \text{ Mpa}$. let take factor of safety 1.5

$$\text{then, } d = \sqrt{\frac{4 * F}{\pi * \tau_{\text{all}}}} = 4.4 \text{ mm. let say 5 mm}$$

For pin connect spring rod and pick up finger

The same procedure and $d = 4.38 \text{ mm}$ let say 5mm

5.3.4. Pick Up Shaft

The shaft has two bearing support and a pulley. Pick finger attach to shaft by pin connection and supported by spring which control load applied on pick up finger due to roughness of ground surface. At bearing support and pulley main shaft and at middle six shaft road used.

5.3.4.1. Design of Shaft Rod

Force due spring decomposed to radial(normal) and tangential component. Both force are make bending moment in radial(n) and tangential(t) direction. the analysis as follows.

✚ Shaft road one

Free body diagram as follows

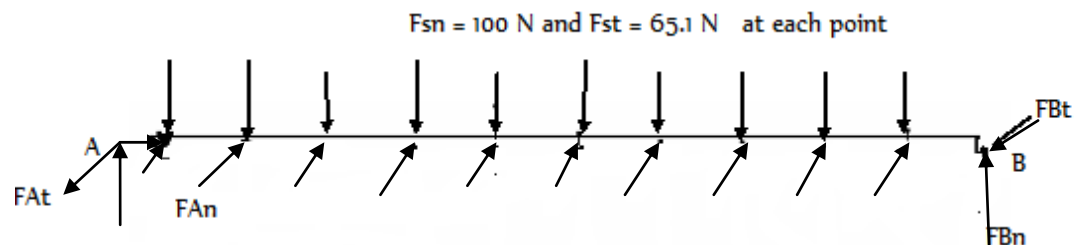

Note: the space in each point is 150 mm except the first gap 25 mm and the last 125 mm gap from support.

Let find reaction force at support M_A in normal

- Normal component: $\sum Mat A = 0 \text{ and } + \text{ in } \cup$

$$0 = -25 * F_{sn} - 175 * F_{sn} - 325 * F_{sn} - 475 * F_{sn} - 625 * F_{sn} - 775 * F_{sn} - 925 * F_{sn} - 1075 * F_{sn} - 1225 * F_{sn} - 1375 * F_{sn} + 1500 * F_{B(n)},$$

then $F_{B(n)} = 466.67 \text{ N}$ for $F_{sn} = 100 \text{ N}$ and $F_{A(n)}$ is obtained by summation force in normal direction. Then $F_{A(n)} = 533.33 \text{ N}$

- Tangential component: $\sum Mat A = 0 \text{ and } + \text{ in } \cup$

$$0 = -25 * F_{st} - 175 * F_{st} - 325 * F_{st} - 475 * F_{st} - 625 * F_{st} - 775 * F_{st} - 925 * F_{st} - 1075 * F_{st} - 1225 * F_{st} - 1375 * F_{st} + 1500 * F_{B(t)},$$

then $F_{B(t)} = 303.8$ and $F_{A(t)}$ is obtained by summation force in tangential direction. Then $F_{A(t)} = 347.2 \text{ N}$.

Bending momentum diagram

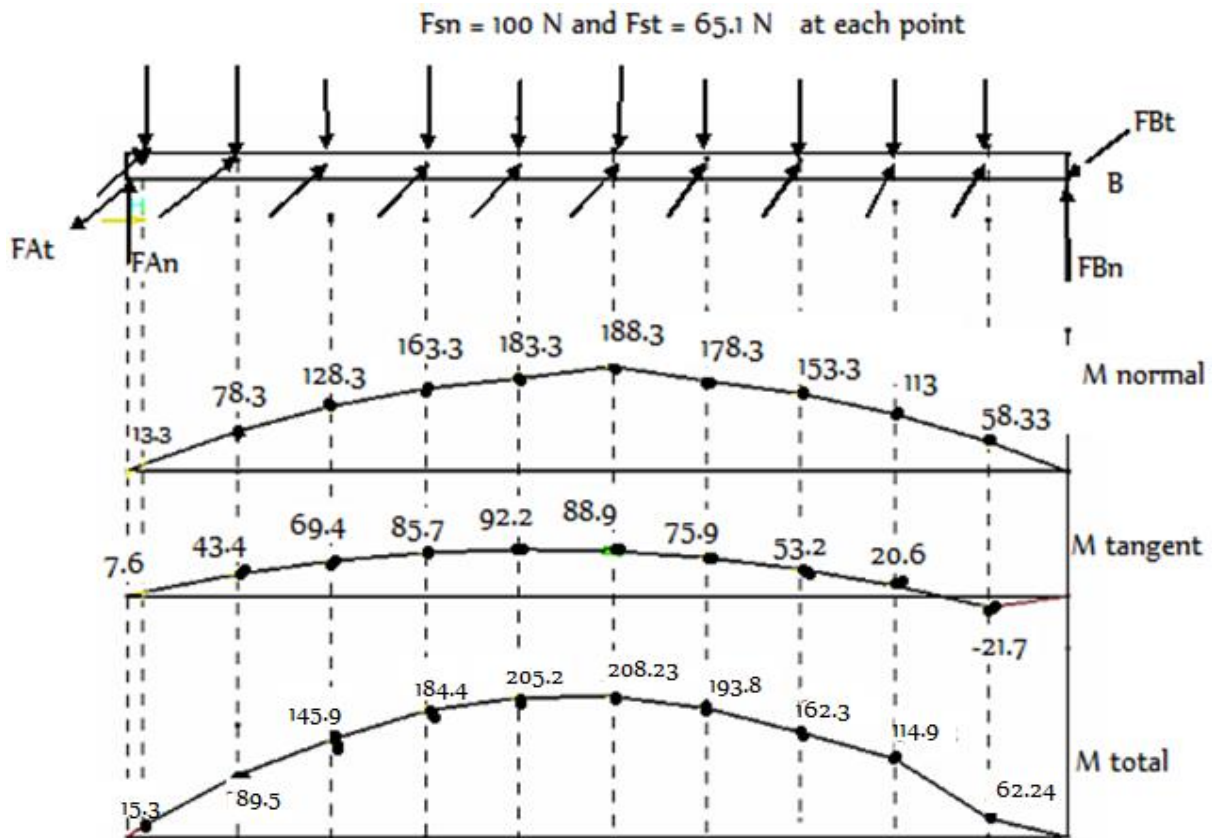

From above bending diagram, total maximum momentum displayed at 750 mm from point A and its value $M = 208.23 \text{ N.m}$. By using this bending moment we can find diameter of road (d)

Bending stress $\sigma_b = \frac{M \cdot C}{I}$ where $c = d/2$ and $I = \frac{\pi \cdot d^4}{64}$, after substitution and simplification:

$$d = \sqrt[3]{\frac{32 \cdot M}{\pi \cdot \sigma_b}} \text{ where } \sigma_b \text{ is allowable bending stress.}$$

material selection: mild steel is selected and let take factor of safety 1.5 and $\sigma_b = 166.67 \text{ Mpa}$.

Then $d = \sqrt[3]{\frac{32 \cdot M}{\pi \cdot \sigma_b}} = 23.34 \text{ mm}$. Let say **d = 25mm**

Note: for all other shaft we can proceed the same procedure as shaft road one and summarized as follows with bending moment diagram

✚ Second shaft road

Free body diagram and bending moment diagram as follows

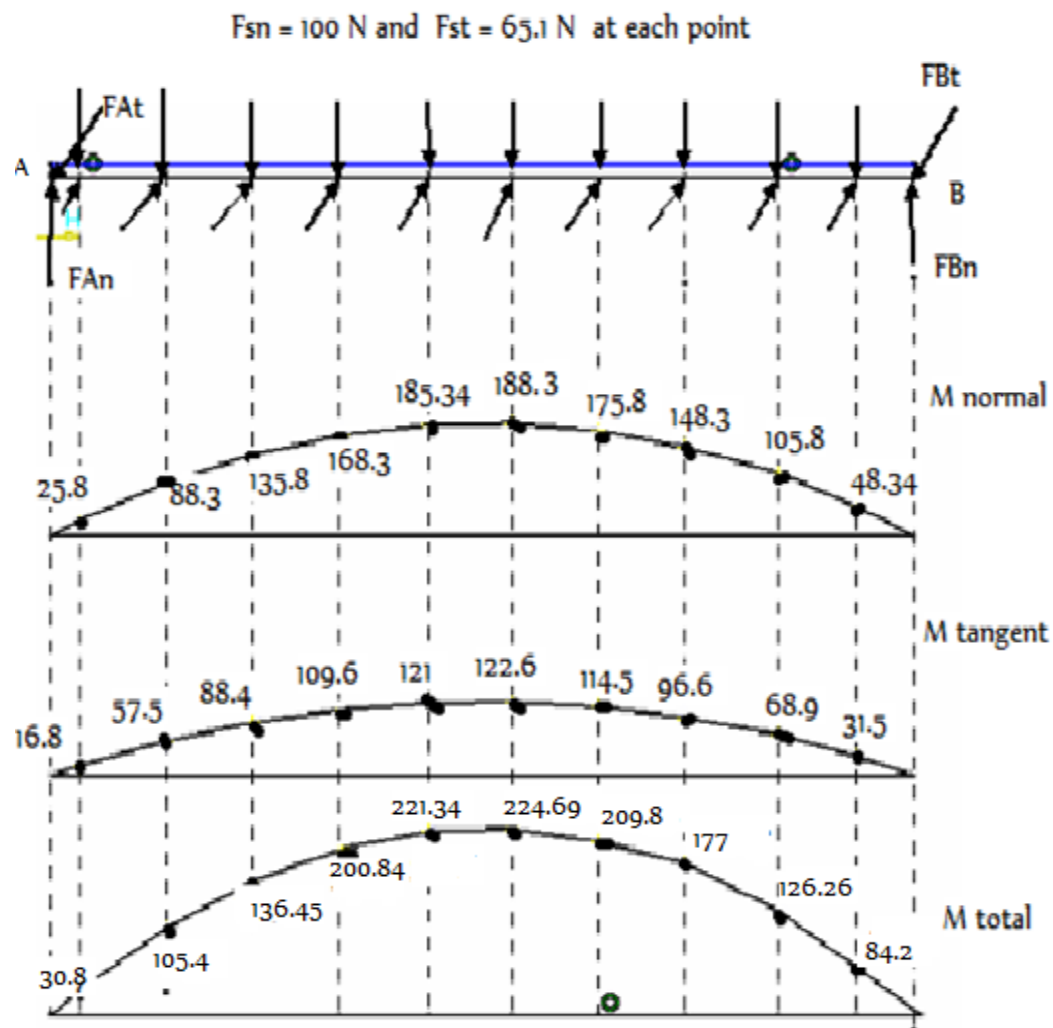

- Total length: 1500 mm, gap between each applied force by spring compression is 150 mm except the first gap 50 mm and the last gap 100 mm
- Reaction force at point A are $F_{An} = 516.67$ N, $F_{At} = 336.35$ N and at point B $F_{Bn} = 483.33$, $F_{Bt} = 314.65$ N. Maximum bending moment is 224.69 Nm and diameter of shaft becomes 23.95 mm. let say **d = 25 mm**.

✚ Third shaft road

Free body diagram

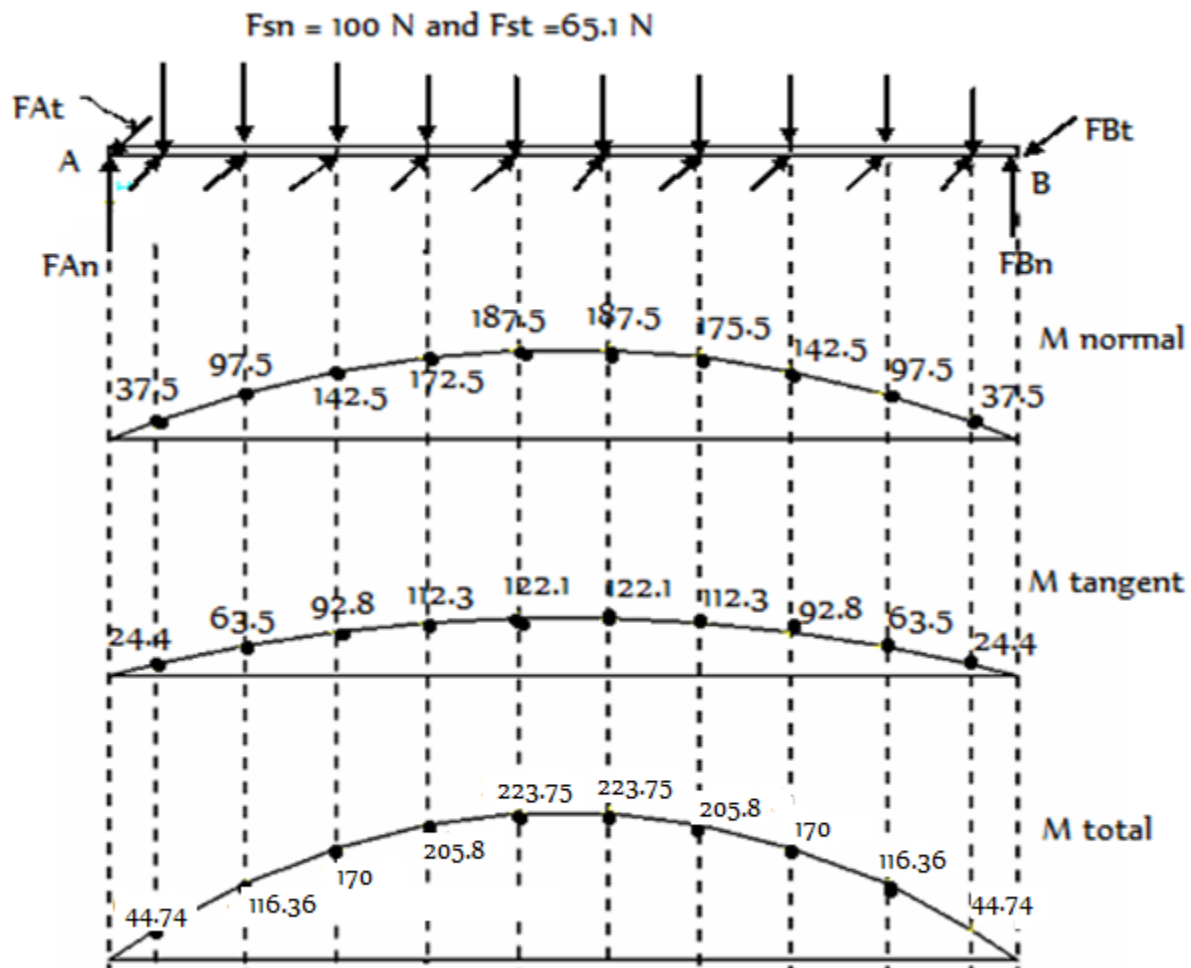

- Total length: 1500 mm, gap between each applied force by spring compression is 150 mm except the first gap 75 mm and the last gap 75 mm
- Reaction force at support: At point A : $F_{An} = 500$ N, $F_{At} = 325.5$ N
At point B: $F_{Bn} = 500$ N, $F_{Bt} = 325.5$ N

- maximum total bending moment : $M = 223.75 \text{ N}$ and material used is mild steel(yield strength :250Mpa. Therefore, $\sigma_{b \text{ allowable}} = \text{yield strength}/ \text{factor of safety}$. let take factor of safety 1.5 and $\sigma_b = 166.67 \text{ Mpa}$.)

- shaft diameter (d) = Then $d = \sqrt[3]{\frac{32 * M}{\pi * \sigma_b}} = 23.9 \text{ mm}$. let say **d = 25 mm**

✚ Fourth shaft road

Free body diagram

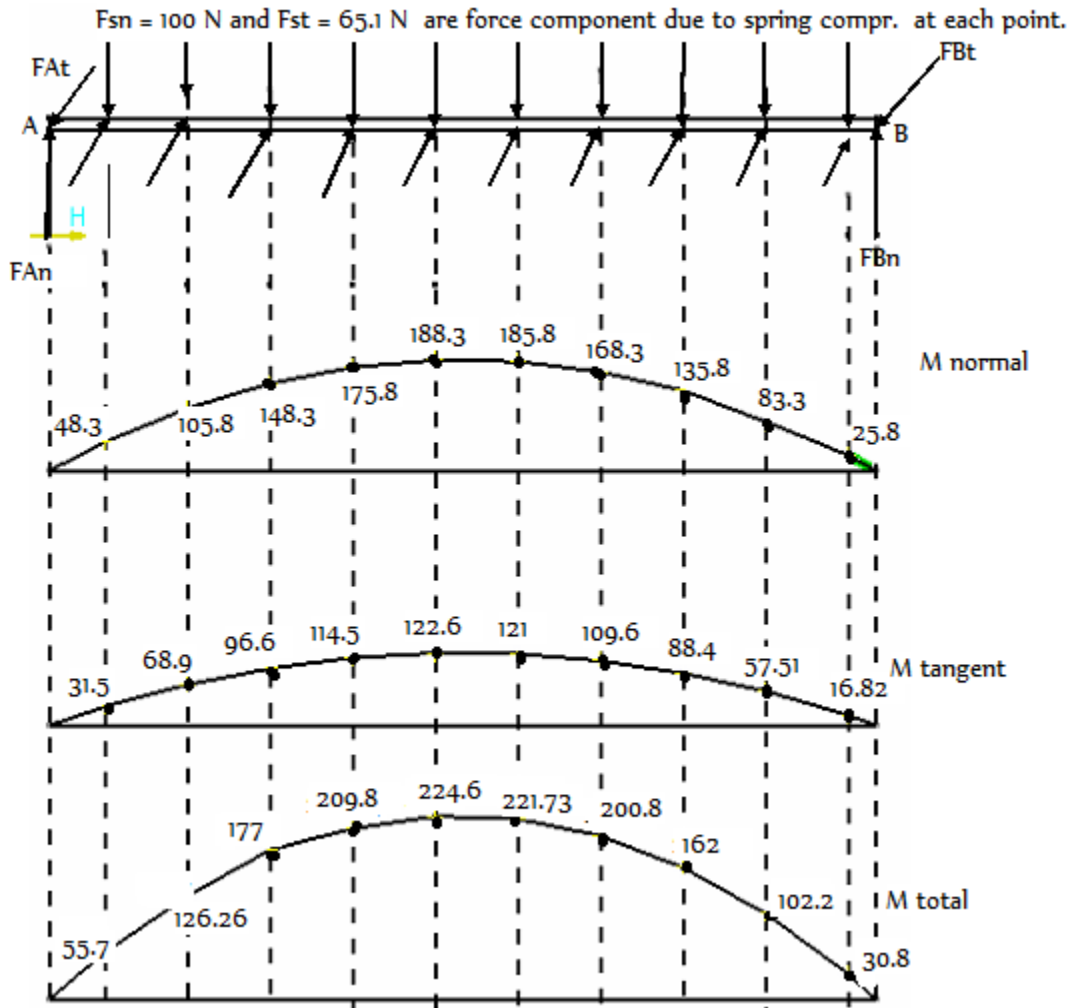

- Total length: 1500 mm, gap between each applied force by spring compression is 150 mm except the first gap 100 mm and the last gap 50 mm
- Reaction force at support: At point A : $F_{An} = 483.33$, $F_{At} = 314.65 \text{ N}$
At point B: $F_{Bn} = 516.67 \text{ N}$, $F_{Bt} = 336.35 \text{ N}$

- Maximum total bending moment : $M = 224.6 \text{ N}$ and material used is mild steel(yield strength :250Mpa. Therefore, $\sigma_b \text{ allowable} = \text{yield strength}/ \text{factor of safety}$. let take factor of safety 1.5 and $\sigma_b = 166.67 \text{ Mpa}$.)

- Shaft diameter (d) = Then $d = \sqrt[3]{\frac{32 * M}{\pi * \sigma_b}} = 23.94 \text{ mm}$. let say **d = 25 mm**

✚ Fifth shaft road

Free body diagram

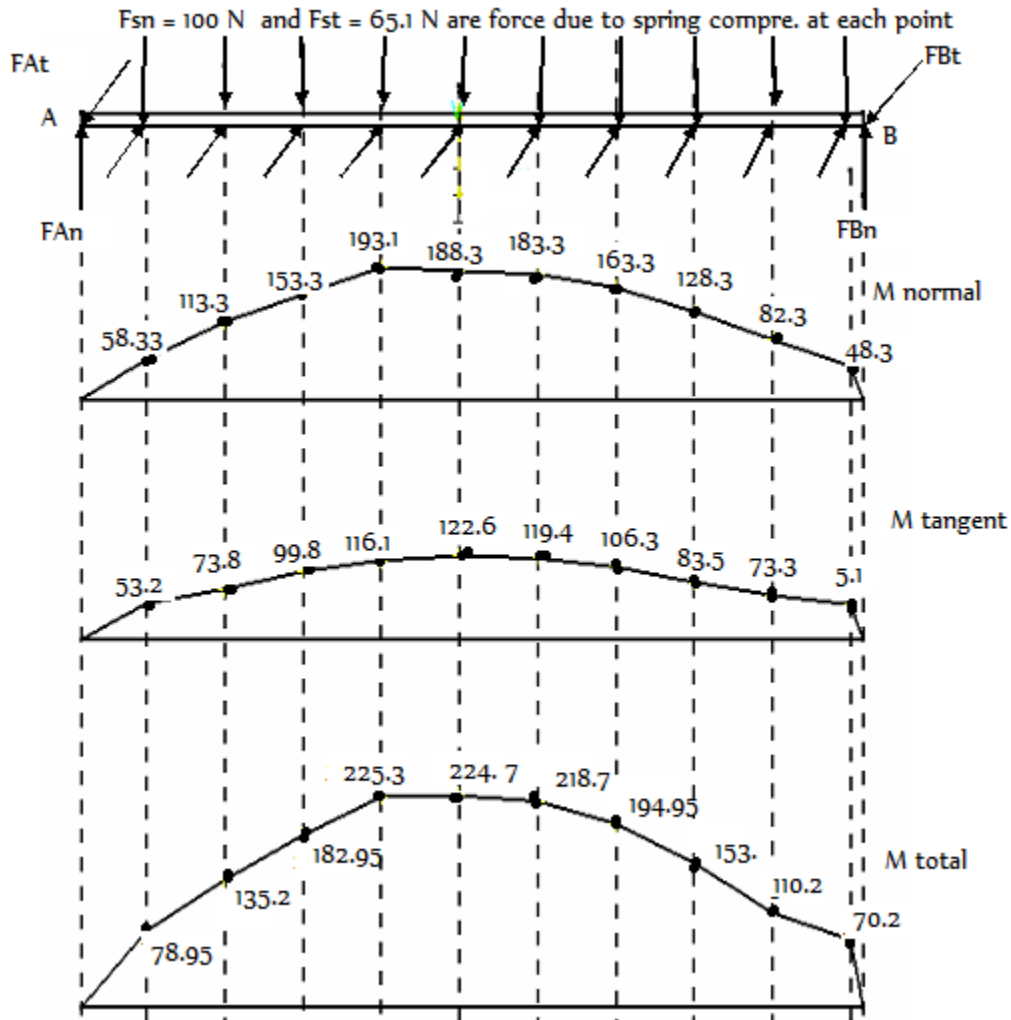

- Total length: 1500 mm, gap between each applied force by spring compression is 150 mm except the first gap 125 mm and the last gap 25 mm
- Reaction force at support: At point A : $F_{An} = 466.67 \text{ N}$, $F_{At} = 303.8 \text{ N}$
At point B : $F_{Bn} = 533.33 \text{ N}$, $F_{Bt} = 347.2 \text{ N}$

- Maximum total bending moment : $M = 224.7$ N and material used is mild steel(yield strength :250Mpa. Therefore, $\sigma_b \text{ allowable} = \text{yield strength}/ \text{factor of safety}$. let take factor of safety 1.5 and $\sigma_b = 166.67$ Mpa.)

- Shaft diameter (d) = Then $d = \sqrt[3]{\frac{32 * M}{\pi * \sigma_b}} = 23.94$ mm. let say $d = 25$ mm

✚ Sixth shaft road

Free body diagram

$F_{sn} = 100\text{N}$ and $F_{st} = 65.1$ N are force due spring compre. at each point.
each point has 150mm space(gap)

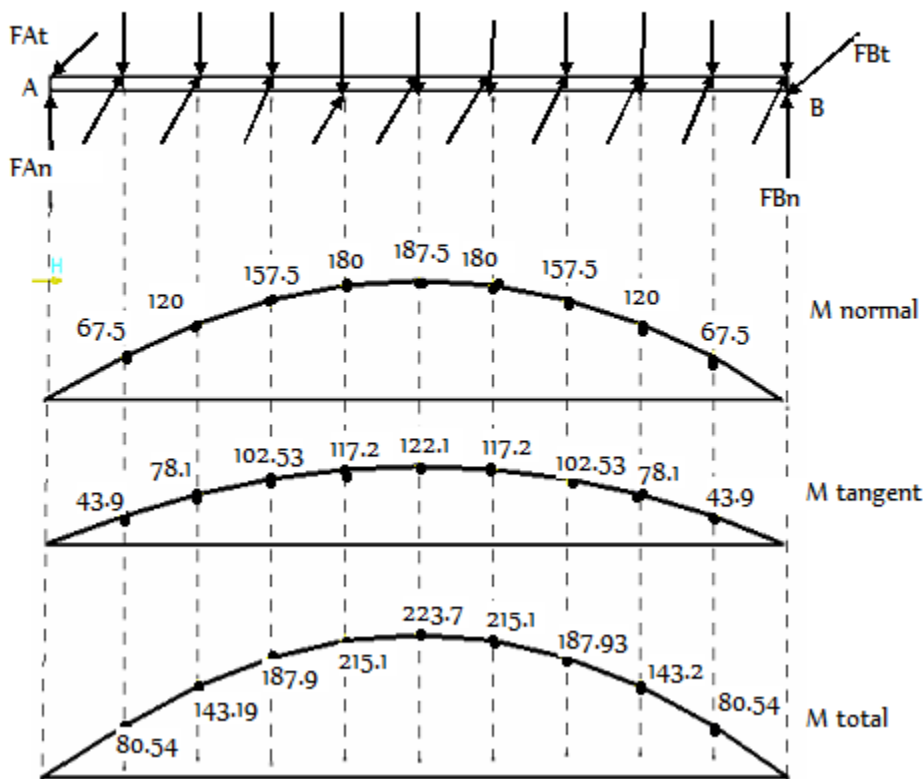

- Reaction force at support: At point A : $F_{An} = 450\text{N}$, $F_{At} = 292.95$ N
At point B: $F_{Bn} = 550$ N, $F_{Bt} = 358.05$ N
- Maximum total bending moment : $M = 223.7$ Nm and material used is mild steel(yield strength :250Mpa. Therefore, $\sigma_b \text{ allowable} = \text{yield strength}/ \text{factor of safety}$. let take factor of safety 1.5 and $\sigma_b = 166.67$ Mpa.)
- Shaft diameter (d) = $\sqrt[3]{\frac{32 * M}{\pi * \sigma_b}} = 23.9$ mm. let say $d = 25$ mm

5.3.4.2. Main Shaft Design

Design of main shaft depends on the weight of pulley, tension by belt and torsion. Both pulley weight and tension by belt produce bending stress, but torsion create shear stress. let ignore weight of pulley since its very small when compare with force created by belt tension(2.978 kN). Free body diagram as follow

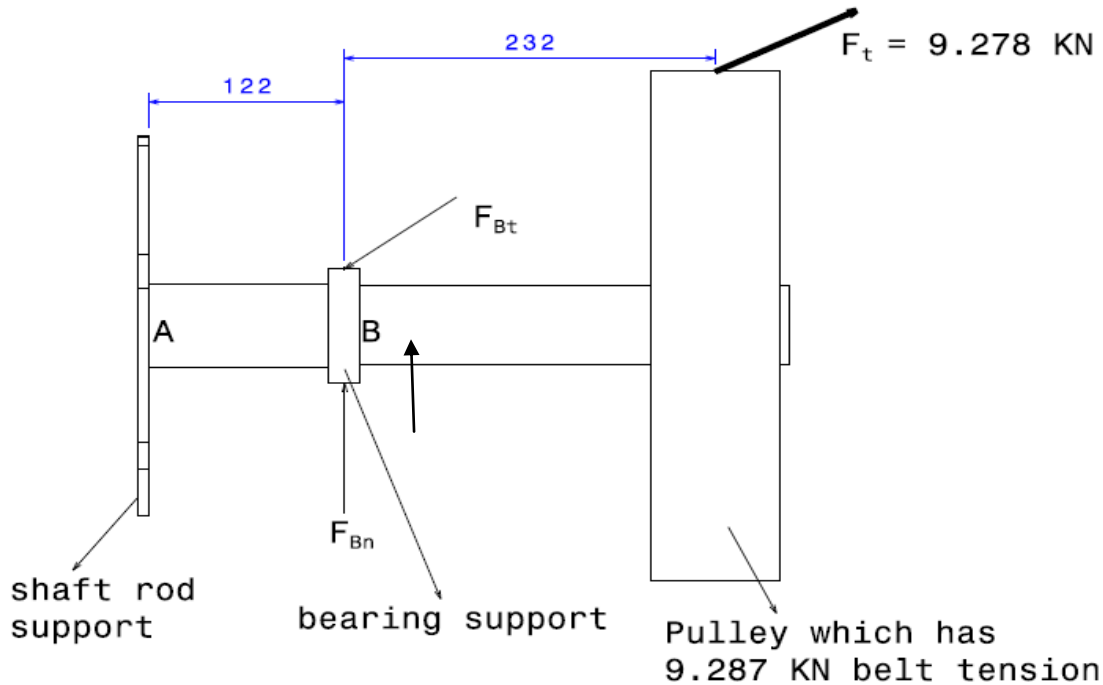

Figure 5. 5 Main shaft of pick up head

Maximum bending moment at case(bearing) support: 1.763 kNm and torque created by pulley calculate under pulley design is 1.25 kNm. Then finding shaft diameter based on stress analysis from both bending moment and torque as drive pulley shaft done at 5.2.3 section. The result becomes 51mm.

Weld Design At Point A

The same procedure as above drive pulley shaft weld analysis but input values as follows

$T = 1.25$ kNm , torsion by pulley belt tension

$M = 1.85$ kNm bending moment at point A

$d = 51$ mm, diameter of shaft

Then, the weld length (s) is 10 mm.

Key Design

By the same procedure as drive shaft, input data as follows:

$T = 1.763$ kNm torsion on driven shaft

$\tau = 115$ N/mm and F.S=1.5 , shear stress of mild steel and factor safety respectively

$d = 51$ mm is the driven shaft diameter

$t = 11$ mm and $w = 18$ mm are thickness and width of key based on standard described under drive shaft

Therefore , key length (l) = 76 mm.

Bearing Selection For Pick Up Shaft

The ABMA(America Bearing Manufacturing Association) has established standard boundary dimensions for bearings which define the bearing bore, the outside diameter (OD), the width, and the fillet sizes on the shaft and housing shoulders (index A-3)

Since maximum load take places at bearing support, we have to be select bearing bore diameter equal to 50 mm. Based on boring diameter outside diameter = 90mm, width= 20mm, fillet radius = 1.0,housing shoulder diameter(d_H) = 82mm and shaft diameter(d_s) is 56 mm.

5.3.5. Pick-up Shaft Support

The support attach to a beam which carry the tire and tire wheel. Load applied on cantilever beams are weight of conveyed material, belt tension load and weight of pick up shaft component.

Let find reaction force at B which on fig 5.7

- I. At a time three rows of pick up finger can carry material. Therefore weight of conveyed material = $1/2 V'_{total} * \text{density of material} * 9.81 \text{ m/s}^2 = 366.51 \text{ N}$
 V_{total} is total volume conveyed per one revolution- discussed under convey analysis.
- II. weight of pick up shaft component
 - ✓ shaft road weight = no of shaft road * volume of each road*density * 9.81 m/s^2
$$= 6 * \frac{\pi d^2}{4} * 15 * 7200 * 981 = 312 \text{ N}$$
let assume weight of spring and spring components are half of shaft road weight. So, the weight of shaft road component becomes $312 * 1.5 \text{ N} = 468 \text{ N}$
 - ✓ Main shaft weight = 173.5 N (The same procedure with shaft road weight analysis)

✓ weight of pulley - 80 N

In general, total weight of pick component is approximately the sum above each weight i.e. $W = 1088$ N and assume center mass at mid-point of pick up header length. The following figure show 2D of pick up head in top view.

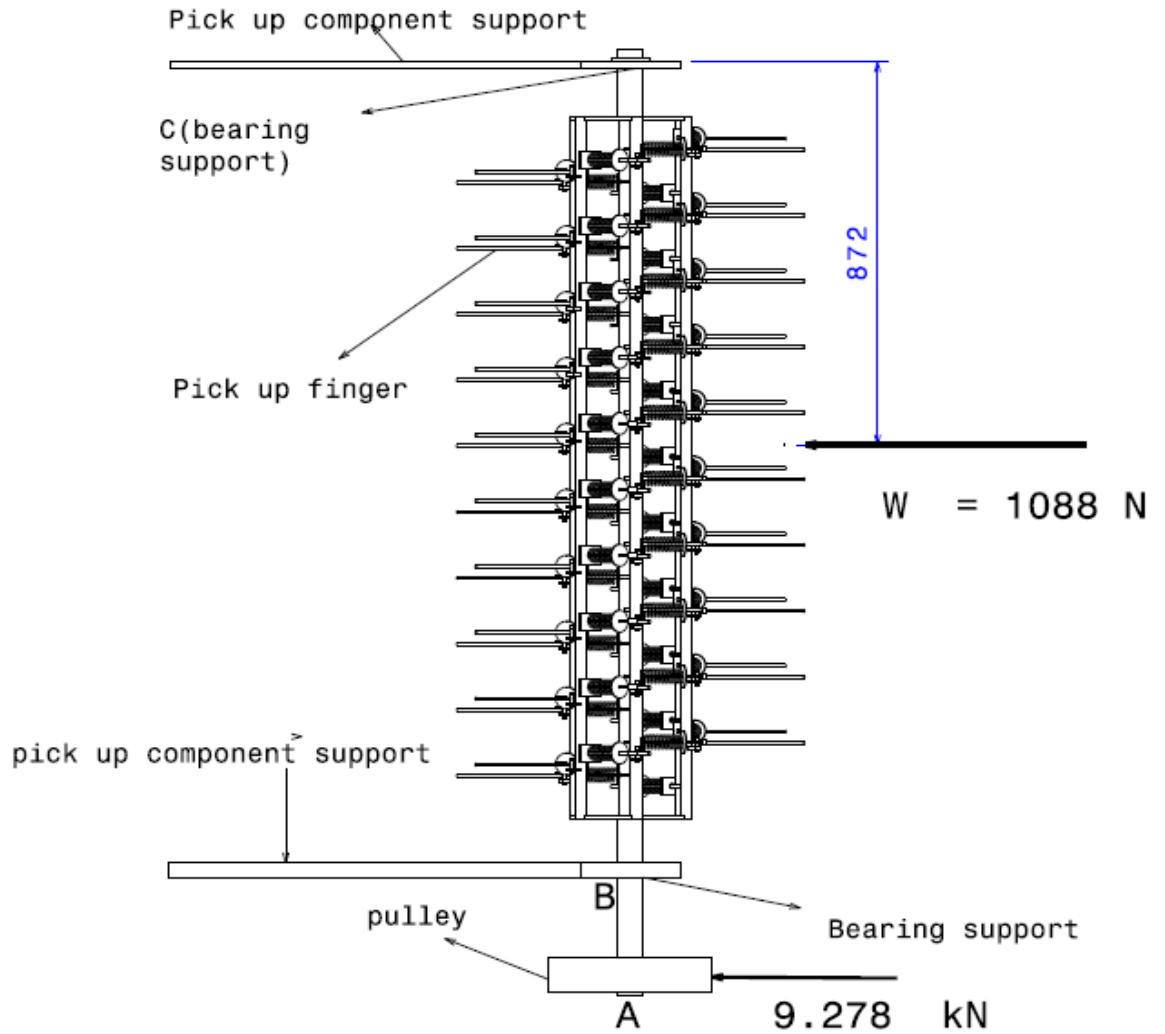
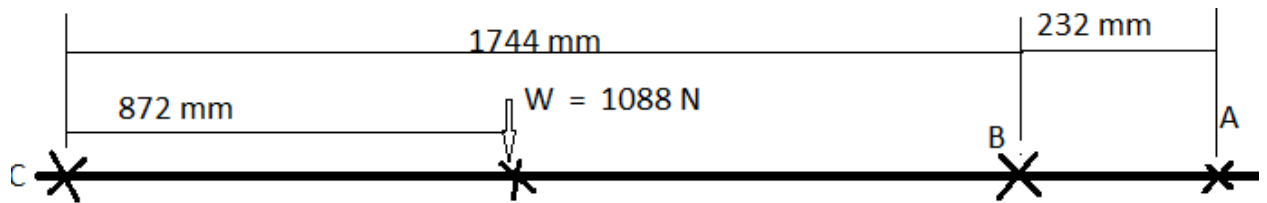

Figure 5. 6 Assemble of pick up head in 2D

To find the reaction force at both bearing support, let represent the above figure as follows:



C and B are bearing support of pick up head and A is pulley connection point

Reaction force At B :- $B_x = 10.5$ kN , $B_y = 883.8$ N

At C :- $C_x = 1.233 \text{ kN}$, $C_y = 460 \text{ N}$

At A :- $A_x = 9.27 \text{ kN}$, $A_y = 335.8 \text{ N}$

free body diagram as follows

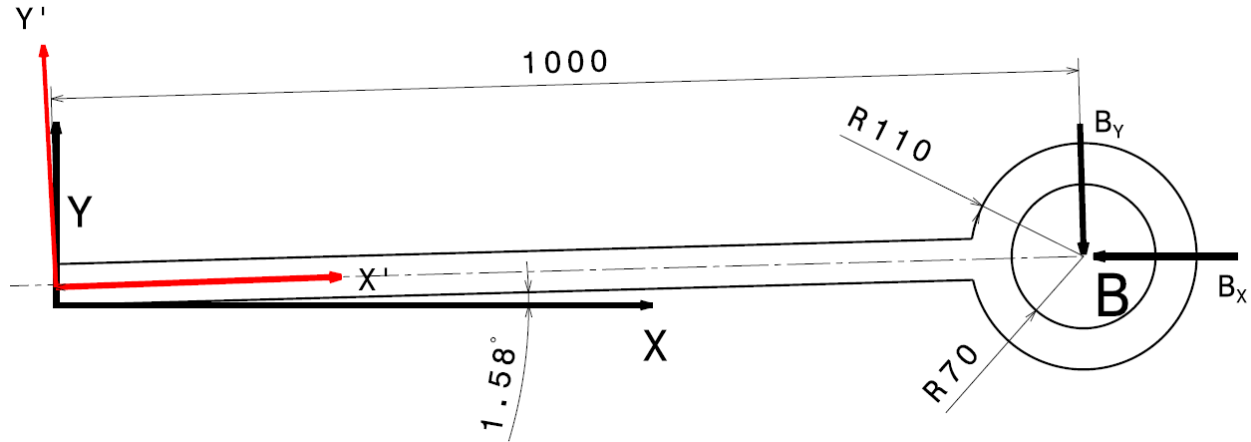

Figure 5. 7 Pick-up shaft support in belt load

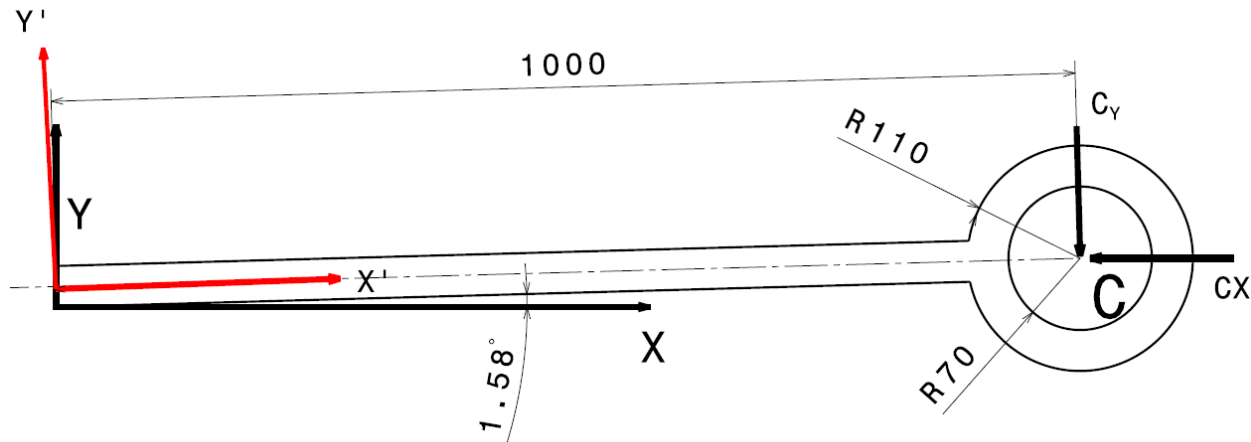

Figure 5. 8 pick-up shaft support in non belt load side

Force in tangential(Y') and normal component(x') for both shaft support are as follows

$$B_{x'} = 10.52 \text{ kN}$$

$$C_{x'} = 1245.2 \text{ N}$$

$$B_{y'} = 1.1729 \text{ kN}$$

$$C_{y'} = 493.8 \text{ N}$$

Based up on resultant reaction force at point C and B, we can design pick up shaft component support device.

Design of pick-up shaft support in belt load side

✚ In compressed surface side(lower surface)

$$\sigma_{c \text{ all}} = \sigma_b + \sigma_{co} = \frac{BX'}{ab} + \frac{6M}{ab^2} \quad \text{where } M = B_Y * 1\text{m} = 1.173 \text{ kNm}$$

let assume $b = 40 \text{ mm}$ and $\sigma_{c \text{ all}} = 350 \text{ Mpa}$ (for mild steel and $f.s = 2$) and we can get $a = 13.34 \text{ mm}$. Let say $a = 14 \text{ mm}$

✚ In tensile surface side(upper surface)

$$\sigma_{t \text{ all}} = \sigma_b - \sigma_{co} = -\frac{BX'}{ab} + \frac{6M}{ab^2}, \text{ for } b = 40 \text{ mm and } \sigma_{t \text{ all}} = 125 \text{ Mpa}$$

Then we can get $a = 33 \text{ mm}$

Therefore, from above both result we can select the larger value, i.e. $a = 33 \text{ mm}$.

Design pick-up shaft support in non belt load side

By the same procedure of a device support at B point, at C also have $a \times b = 15 \text{ mm} \times 40\text{mm}$ cross-section area.

Enclosing Cylinder

The development of enclosing cylinder is as follows:

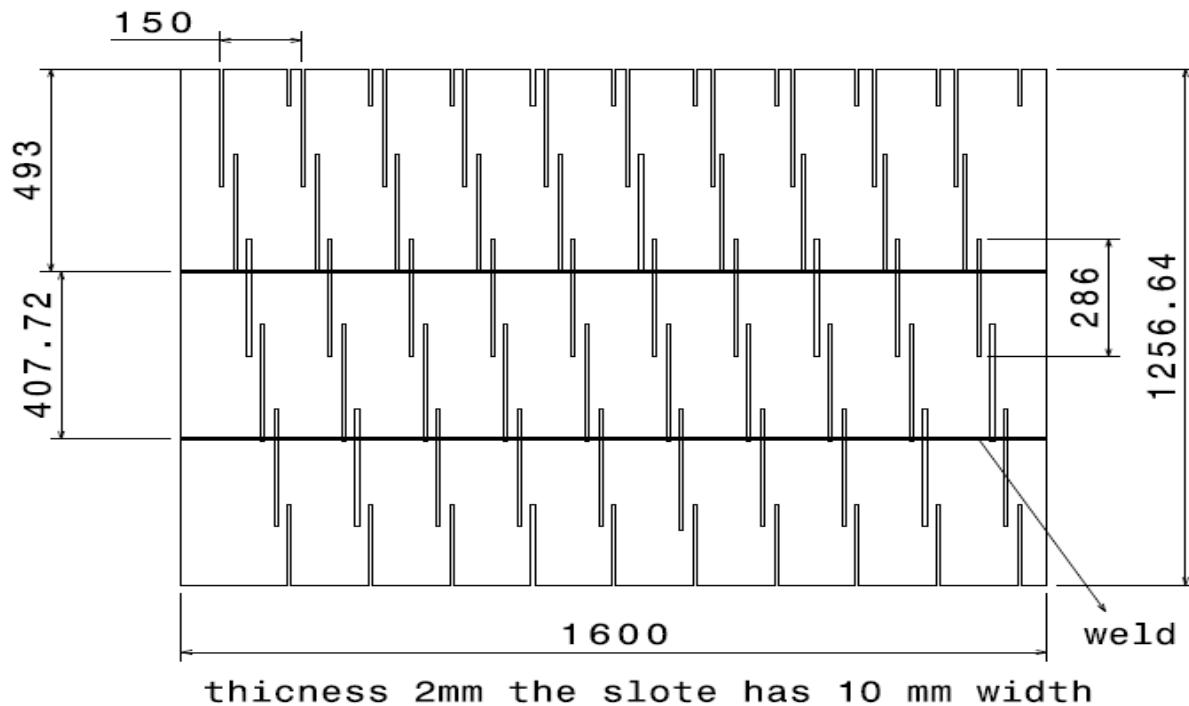

Figure 5. 9 Development of enclosing cylinder

Each slot helps to allow the movement of pick up finger when spring compressed and the length of each slot 286 mm and width is 10 mm. To simplify assemble method, divide the cylinder development into three part as shown on fig 5.9.and weld together during assemble.

5.4. Design of Conveyor

A Conveyor elevator consists of a series of uniformly fed rod weld to flat metal which mounted on an endless of belt by bolt. The rod are used to elevate the hay by pushing. The material is received at the boot (by means of digging since there is no resistance to extraction), raised and then discharged before passing over the head wheel at the top (by gravity). The casing help to guide the hay under the action of pushing force for upward direction (lower part).

Necessary information

- Hay has bulk density $5 \text{ lb/ft}^3 = 2.3 \text{ kg} / (0.3048)^3 \text{ m}^3 = 81.22 \text{ kg/m}^3$ for non pressed
- Maximum duty (material flow rate): the flow rate of material relate with the amount of picked up material by pick up finger. From fig 5.5 we can find the volume of hay transferred (picked up) in one revolution of pick up shaft.

$V'_{\text{total}} = \text{area of hay} * \text{pick up width} * 6$, where V'_{total} is total volume for one revolution
 $= 0.028 * 1.5 * 6 \text{ m}^3 = 0.252 \text{ m}^3$ per revolution. one revolution is taken in 1.12sec time.

Therefore flow rate in terms of volume $Q' = 0.225 \text{ m}^3/\text{sec}$.

- Maximum lump size: assume the effect of hay length negligible
- Height the hay to raised: 4 m

Select conveyor Size and Spacing (area)

Volume of between conveyor elevator: $300 \times 500 \times 250 \text{ mm}^3$ (width, depth and height of working area of elevator). Therefore, to move $0.225 \text{ m}^3/\text{sec}$ using $300 \times 500 \times 250 \text{ mm}^3 (0.0375 \text{ m}^3)$ requires 6 elevator conveyor per sec

Determine Belt Speed

Conveyor elevator spacing times number of buckets per second determine the required speed of belt- range 1 to 2 m/s. let assume $V = 1.5 \text{ m/sec}$. Then the space becomes:

space between bucket = $V/\text{number of bucket per sec} = 136 \text{ mm}$

Held Pulley Diameter

Assume the pulley system as discharging after of passing over head.

Then , $r = V^2/g = 0.230\text{m}$ and $D = 2r = 0.460\text{m}$

Belt Tension

Belt tension allows: $T_1 = \frac{\frac{P}{v}}{1 - \frac{1}{e^{\mu\theta}}}$ where P is power and V is speed of belt. let find

power(P) = F x V where F is the results from the weight of product lifted by five elevator conveyor content those move upward plus the dredging drag as the bucket scoops up the product.

elevator load : density x volume per elevator x 5 = $81.22 \text{ kg/m}^3 * 0.0375 \text{ m}^3 * 5 = 15.23 \text{ kg}$

dredging load : $\frac{90 \times W_s}{P_s}$ (BENTLEY)

$$= 2015.6\text{kg}$$

W_s - weight of material in each elevator

P_s - elevator conveyor spacing on belt (m)

Total pulley load(F) = $15.23 + 2015.6 \text{ kg} = 2030.82 \text{ kg}$. Therefore, $P = 3.023 \text{ kw}$.

Belt tension allows: $T_1 = \frac{\frac{P}{v}}{1 - \frac{1}{e^{\mu\theta}}} = 3.6 \text{ kN}$

$$T_2 = T_1 / e^{\mu\theta} = 1.64 \text{ kN} \quad \text{where } \mu = 0.25 \text{ for rubber on steel and } \theta = \pi$$

Belt cross-section (A = b x t)

The maximum tension ($T = 3.6 \text{ kN}$) = Maximum stress x Cross-sectional area of belt

$$= \sigma_{\max} * b * t \quad \text{but } \sigma_{\max} = \sigma_{\text{ult}} / f.s$$

for $t = 4.2 \text{ mm}$ and $\sigma_{\text{ult}} = 15 \text{ Mpa}$, $f.s = 5$ the width of belt(b) becomes 286 mm . From standard elevator belt width shown in index A, select $b = 304.8 \text{ mm}$.

Pulley Dimension

For selected belt width ($b = 304.8 \text{ mm}$) and relation of belt width with pulley width as on index C-1, pulley width can be 355.6 mm . Approximated weight of this selected pulley is 37 kg

Shaft Design For Pulley

Free body diagram as follows

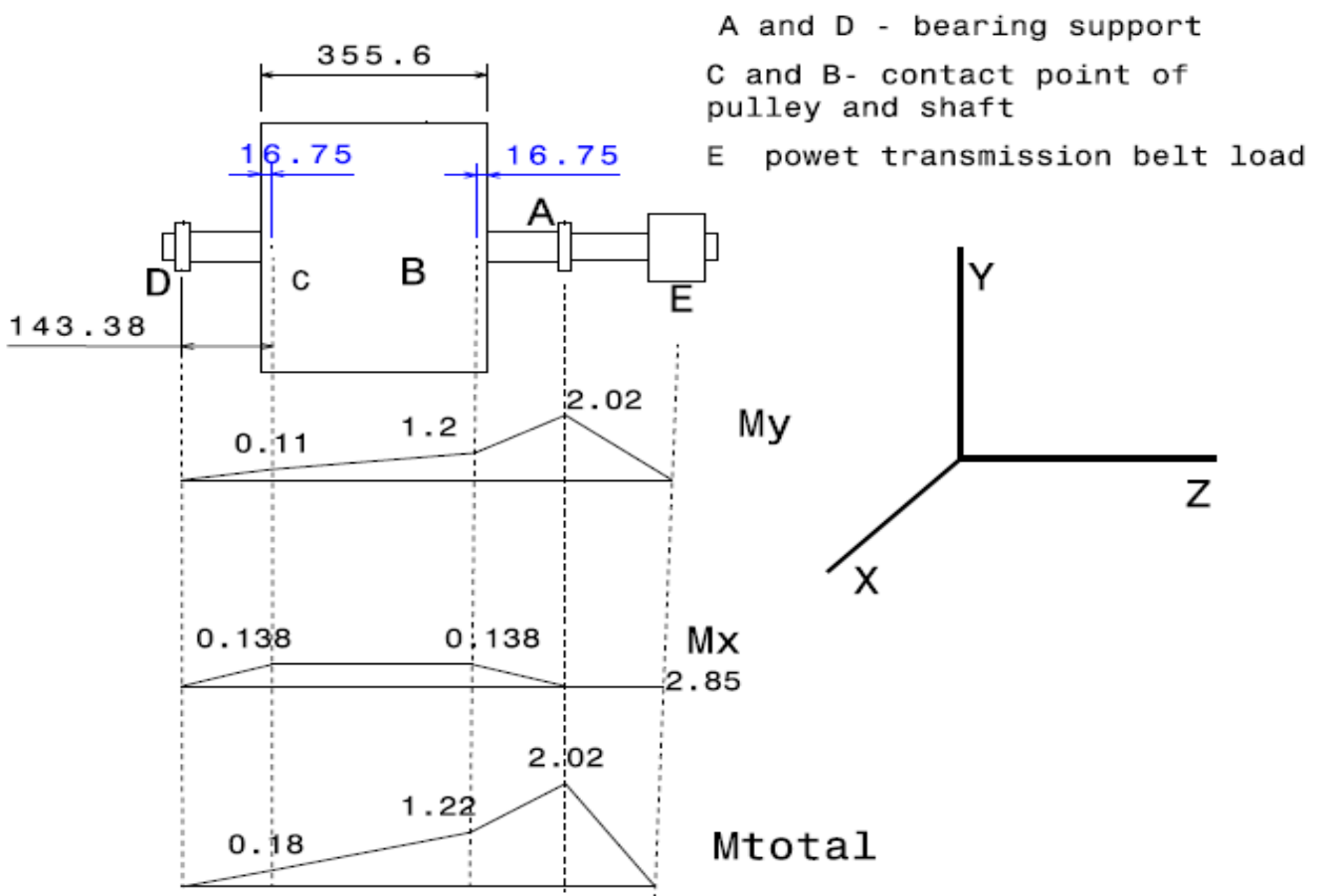

Figure 5. 10 Free body diagram of conveyor head pulley

The shaft undergoes bending and torsion simultaneously. Reaction force at D, C, B, A and E are summarized as follows:

- Force at C and B are due to weight of pulley(37 kg *9.81 m/s²) and belt tension.
 $B_x = C_x = 1/2(T_1 + T_2) \cos \theta = 1 \text{ kN}$
 where $\theta = 67.44^\circ$ is inclination of bucket $T_1 = 3.6 \text{ kN}$ and $T = 1.64 \text{ kN}$
- Reaction force at bearings : $D_x = 1 \text{ kN}$, $D_y = 764 \text{ N}$, $A_x = 1 \text{ kN}$ and $A_y = 17.498 \text{ kN}$
- Belt power transmission load : $E_y = 11.534 \text{ kN}$

From above bending moment diagram

- M- maximum bending moment is 2.02 kNm
- T- maximum torque is 0.464 kNm

$$\sigma_{all} * Z = \sqrt{K_b * K_{cb} * M^2 + K_t * k_{ct} * T^2} \dots\dots\dots \text{eq 4.1}$$

where K_b shock factor of bending- 1.5 to 2 for minor shock and 2 to 3 for heavy shock

K_{cb} stress concentration factor for bending

K_t shock factor of torsion- 1 to 1.5 for minor shock and 1.5 to 3 for heavy shock

K_{ct} stress concentration factor for torsion

σ_{all} allowable stress

Z polar section of modulus = $\frac{\pi d^3}{16}$ for solid circular cross section.

For minor shock let select $K_b = 1.5$, $K_{cb} = 1.5$, $K_t = 1.5$ and $K_{tc} = 2$. For mild steel material ($\sigma_{all} = 166.67$ Mpa when $f.s = 1.5$), then diameter of shaft can calculated based eq 4.1 and its value is 45.7 mm. To relate shaft diameter with standard bore diameter of bearing, shaft diameter selected 50 mm.

Bearing Selection

Based on selected shaft diameter bearing geometry also as follows

- boring diameter = 50 outside diameter = 90mm
- width= 20mm fillet radius = 1.0, housing
- shoulder diameter(d_H) = 82mm and shaft diameter(d_s) is 56 mm.

Mounting Method

Rod weld to flat metal that mount to belt by means bolt attach and split segments arrangement to make belt the perfectly configured to the diameter of the pulley.

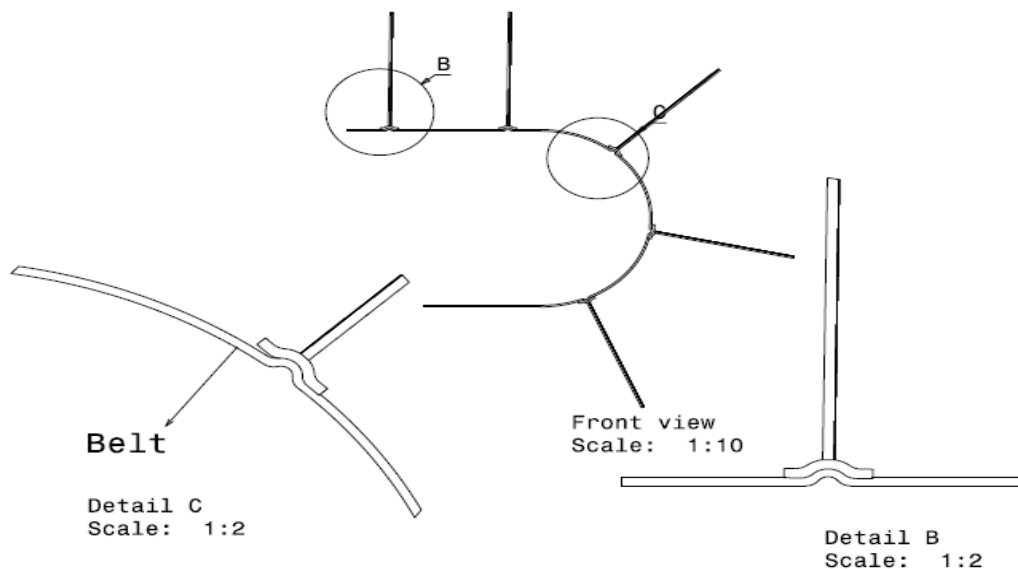

Figure 5. 11 Mounting method belt and road conveyor

Connection of End Belt

Belt is clamped by means of bolt between a mild steel wedge and tow steel damping jaw. The number of bolt depends on the wide of belt.

Bolt Selection

Tensile stress: load on bolt due to belt tension (T_1) bring bolt to tensile stress.

$$T_1 = A \times \sigma_{t, all} \times n$$

where $A = \frac{\pi}{4} * d^2$ is cross section area at d (core diameter)

$\sigma_{t, all}$ - allowable tensile stress which is equal to 80 Mpa (A193 steeliness steel)

n - number of bolt let assume 4.

Then, $d = 3.7$ mm and from standard $d = 4$ mm

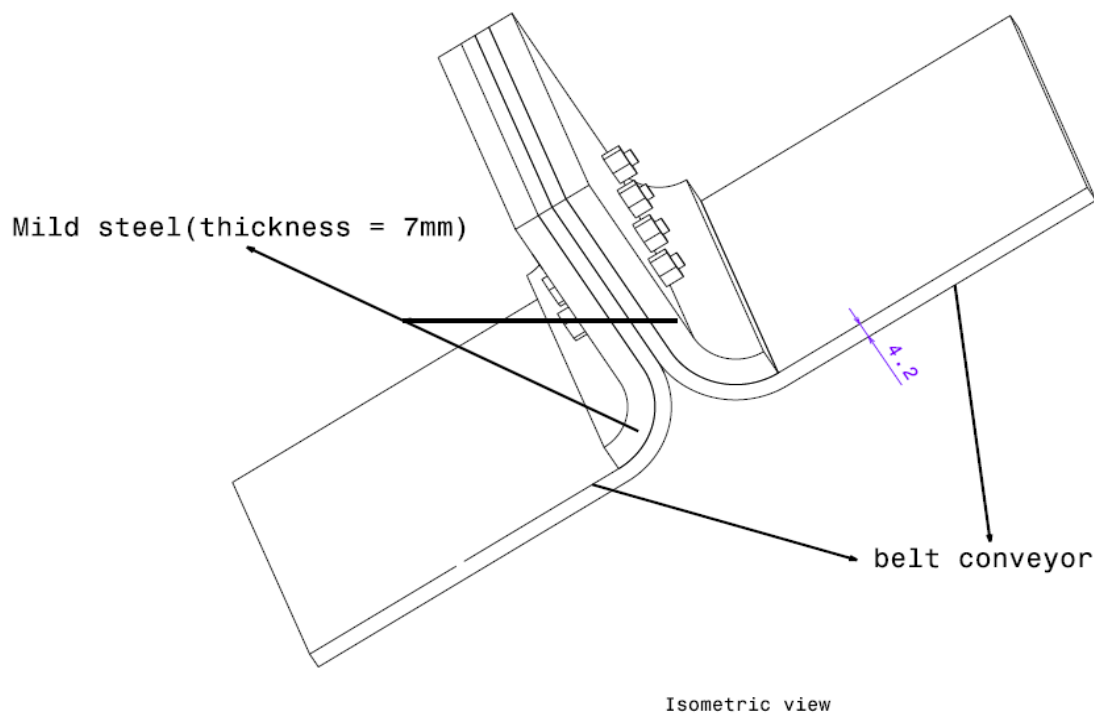

Figure 5. 12 End joint of conveyor belt

Cross-section area of steel body:

Shear stress applied on steel body due to belt tension.

$\tau_{all} = \frac{F}{A}$ and $F = T_1 = 3.6$ kN - maximum tension in belt and $A = b * a$, $b = 304.8$ mm which the same with belt width. Take material is mild steel($\tau = 700$ Mpa) and $F.s = 3$ since hollow for

bolt which increase stress concentration factor. After substitution $F = 3.6 \text{ kN}$, $b = 304.8$, $\tau_{all} = \tau / F.s = 233.3 \text{ Mpa}$, the value of $a = 8 \text{ mm}$.

Cords of Conveyor

Cords of conveyor must be resist load such as tension due to belt of power transmission, tension by bucket belt, weight of pulley, weight of conveyed material and etc.

❖ For side in which power transmission load applied

Reaction force at point A is calculated under head pulley shaft design. However, reaction force at point A has tangential and normal force (calculated under head pulley shaft design) which produce bending stress and compressed stress respectively. To reduce bending stress at bottom use road EF as truss support. To find reaction force at E

$$\sum M_{Gy} = 0, +\cup$$

$$F_{yE} * S' - F_{tA} * S = 0 \quad \text{where } S = 3790 \text{ mm}, S' = 1954 \text{ mm and}$$

$$R_y = F_{tA} = F_{Ay} * \cos 67.44^\circ - F_{Ax} * \sin 67.44^\circ = 5.79 \text{ kN}$$

$$\text{Then } F_{yE} = 11.23 \text{ kN.}$$

Maximum bending moment take place at point E which is equal to

$$M_E = R_y * (S - S') = 10.63 \text{ kNm}$$

Bending stress: $\sigma_b = \frac{M * Y}{I}$, But $I = \frac{b * a^3}{12}$ and $y = -a$ or a for compressed and tensile respectively

Compressed stress: $\sigma_{co} = \frac{R_x * l}{A}$ where $A = a * b$ - is cross section area

Maximum compressed stress at lower edge (by both normal force and bending moment)

$$\sigma_c = \sigma_b + \sigma_{co} = \frac{R_x * l}{ab} + \frac{6 M}{ba^2}$$

For material mild steel, maximum compressed stress is 750 Mpa and let factor of safety 2, $\sigma_{c \text{ all}} = 350 \text{ Mpa}$ and let assume $a = 150 \text{ mm}$. Substitute $R_x' = -F_{Ax} * \cos 67.44^\circ - F_{Ay} * \sin 67.44^\circ =$

$$16.54 \text{ kN (compress)}, M = 6 \text{ kNm and } a = 150 \text{ mm in } \sigma_{c \text{ all}} = \frac{R_x}{ab} + \frac{6 M}{ba^2} =$$

Therefore, $b = 8.4 \text{ mm} \dots\dots\dots *$

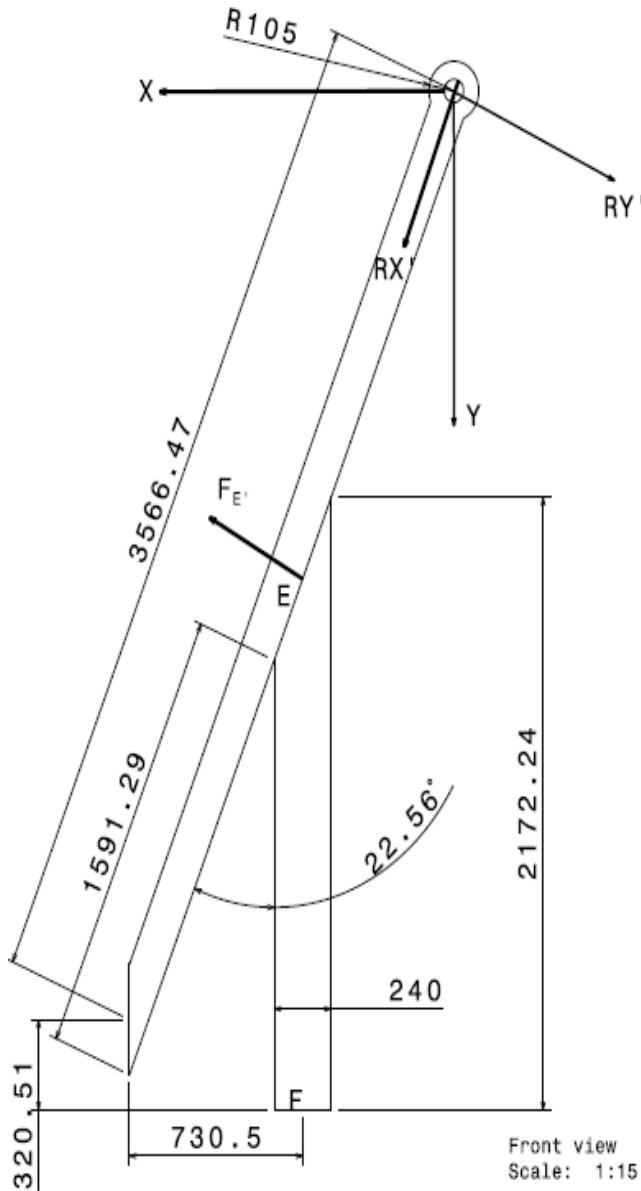

Figure 5. 13 Chord conveyor in power transmission load

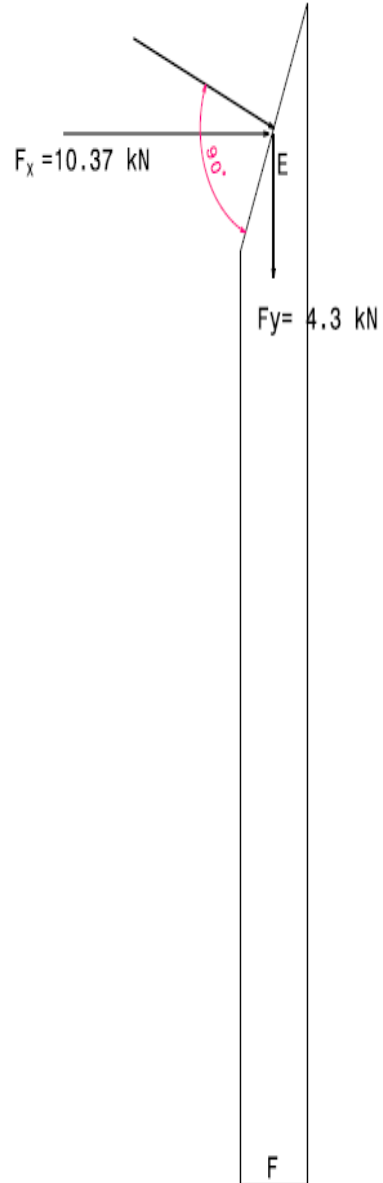

Figure 5. 14 Truss EF

Maximum tensile stress take place at upper edge

$$\sigma_{t \text{ all}} = \sigma_b - \sigma_{co} = -\frac{RX}{ab} + \frac{6M}{ba^2} \quad \text{for} \quad \sigma_{t \text{ all}} = 125 \text{ Mpa and } a = 150 \text{ mm}$$

Then, $b = 12.8 \text{ mm}$, let say $b=13 \text{ mm}$

From above * and ** result, we shall take largest of two i.e $b= 13 \text{ mm}$ and $a = 150 \text{ mm}$

❖ **For side in which power transmission load not applied**

all procedures are the same with a side in which power transmission load applied. all information are summarized in the following table.

Part	Description	Remark
$R_{X'}$	0.322 kN	tensile force as direction described in fig 4.15
$R_{Y'}$	1.22 kN	Tangential force as direction in fig 4.15
F_E	2.366 kN	Reaction force at support direction as in fig 4.15
M_{max}	2.4 kNm	Maximum bending stress at E
Allowable stress	$\sigma_{c, all} = 350 \text{ Mpa}$	Mild steel: $\sigma_c = 750 \text{ Mpa}$ and $\sigma_b = 250 \text{ Mpa}$, F.S = 2
	$\sigma_{b, all} = 125 \text{ Mpa}$	
Cross section area	150 mm x 5 mm	a x b

❖ **Truss geometry**

a. For EF truss

Force applied on truss has tangential and normal force component.

✓ tangential component: $F_E \sin 67.44 = 10.37 \text{ kN}$

✓ normal component : $F_E \cos 67.44 = 4.3 \text{ kN}$

Let find cross section area of truss

$$\sigma_b = \frac{M}{Z} \dots \text{bending stress}$$

$$\sigma_{co} = \frac{FY}{A} \dots \dots \text{compressed stress}$$

for cross section area $\rightarrow A = b \times a'$ and $z = \frac{b \cdot a'^2}{6}$ and $M_{max} = EF \cdot 10.37 \text{ kN} = 27.6 \text{ kNm}$

➤ under tensile surface side $\sigma_{b, all} = \frac{M}{Z} - \frac{FY}{A} = 6 \frac{M}{b \cdot a'^2} - \frac{FY}{a' \cdot b}$, then substitute $M = 27.6 \text{ kNm}$

$F_y = 4.3 \text{ kN}$, $b = 22 \text{ mm}$ (for simple assemble) and $\sigma_{b, all} = 125 \text{ Mpa}$ for mild steel with F.S=2. we get $a=246 \text{ mm}$

➤ under compressed surface side $\sigma_{c all} = \frac{M}{Z} + \frac{RX}{A} = \frac{M}{b \cdot a'^2} + \frac{RX}{a' \cdot b}$ and we can get $a = 146 \text{ mm}$

From comparison in both side, we select the lager value i.e. $a' = 246 \text{ mm}$

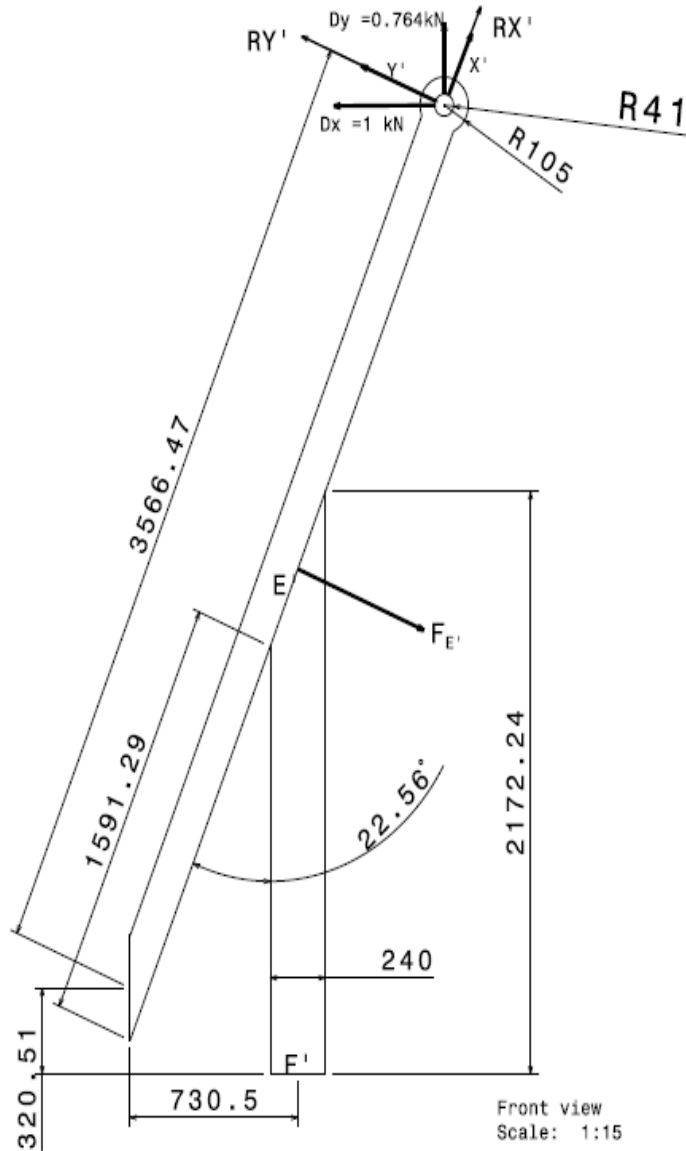

Figure 5. 15 Chord support in non power transmission load

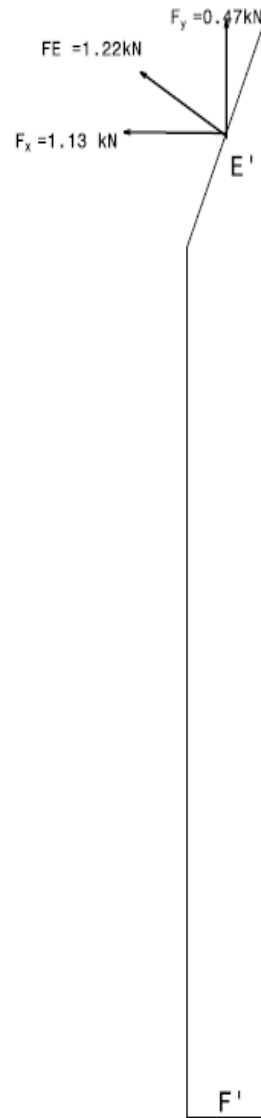

Figure 5. 16 Truss E'F'

b. For E'F' truss

Force applied on this truss are tangential (F_x) and tensile (F_y) force as figure 4.16. Therefore ,

bending stress $\sigma_{b, all} = \frac{M}{Z} + \frac{F_y}{A} \rightarrow$ where $M = 3.1 \text{ kNm}$, $b = 5 \text{ mm}$.

Therefore, $b = 5 \text{ mm}$ and $a' = 130 \text{ mm}$, the same procedure with EF truss analysis

Block at Boot

They are normally available with a range of different rolling contact bearings fitted within the housing— ball or roller, single or double row, self aligning or deep groove type, depending on the application and the probability of misalignment. The housing also makes provision for seals to retain lubricant, while the mounting feet make it easy to attach the housing to a base plate or frame.

Flange bracket units - ucfb

This mounting has three set holes on only one side of the flange. Used where mounting space is limited and the housing can be fixed on one side only.

For bore diameter 50mm the dimension of each variable index C-4 are as follows:

$H_1 = 82\text{mm}$	$L = 114\text{mm}$	$J = 58\text{mm}$	$A_2 = 22\text{mm}$	$d = 50\text{mm}$
$H = 68\text{mm}$	$P = 86\text{mm}$	$A = 39\text{mm}$	$E = 54.6\text{ mm}$	mass: 2.3 kg
$H_0 = 184\text{ mm}$	$i = 46\text{ mm}$	$A_1 = 16\text{mm}$	$S = 19\text{ mm}$	$N = 12\text{ mm}$

housing No : FB210

Block support at boot

Force applied are due to pulley weight, conveyor belt tension and force by cord of conveyor.

Then reaction force on block support as follows:

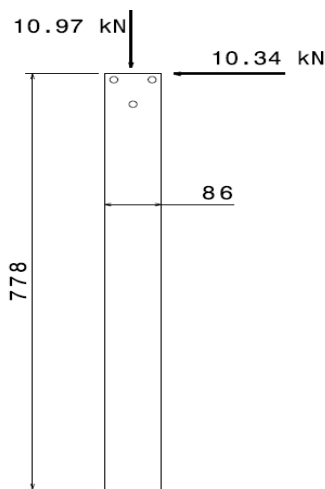

Figure 5. 17 Block support in belt load applied

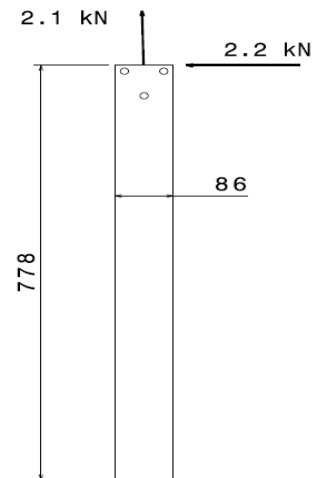

Figure 5. 18 Block support in non belt load applied

Let find cross-section area of block need for resist all applied force without fail

❖ **For block support in belt power transmission load side**

M - maximum bending moment = 8.04 kNm and for mild steel material the cross-section area becomes $A = 54 \times 86 \text{ mm}^2$

❖ **For block support in non belt power transmission load side**

M - maximum bending moment = 1.7 kNm and for mild steel material the cross-section area becomes $A = 12 \times 86 \text{ mm}^2$

5.4. Power Transmission System For Conveyor Head From Wheel of Tire

Belt Selection and Its Component

All procedure the same as belt selection for power transmission of pick up finger. Table below give summarized necessary dimension and information.

Part		Specification	Remark
Pulley diameter	Drive	$D_1 = 224 \text{ mm}$	Find from velocity relation
	Driven	$D_2 = 125 \text{ mm}$	Assumption(based on shaft diameter and aim to reduce weight)
Angular velocity of pulley	Drive	$\omega_1 = 3.6 \text{ rad/sec}$	Calculated at section 4.1.1
	Driven	$\omega_2 = 6.52 \text{ rad/sec}$	Calculate from speed of belt bucket conveyor
Total belt length	L	$L = 7.55$	Based on equation 3.4 for $\alpha = 2.5^\circ$ and center distance 3.5 m
Contact angle	Θ	$\theta = 182.5$	$180 + 2 \alpha$
Belt tension	Tight side	$T_2 = 7.544 \text{ kNm}$	Calculated based on equation 3.3 and 3.5
	Slack side	$T_1 = 3.99 \text{ kNm}$	
Belt cross-section	Thickness	$t = 6.5 \text{ mm}$	Assumption from standard
	Width	$b = 73 \text{ mm}$	Calculated by relate stress times cross-section with maximum tension for $\sigma_{ult} = 35 \text{ Mpa}$, factor of safety(f.s) = 2. Then $b = 66.31 \text{ mm}$. from standard $b = 73 \text{ mm}$ select.
Drive shaft	Diameter	$D = 60 \text{ mm}$	Material is mild steel and f.s is 1.5

Key	Length, thickness and depth	38 x 12 x 20 mm	L x t x w (gibs key tapered by 1:100) and material is mild steel.
Pulley dimension	Width of pulley	90 mm	1.25 b, then find standard value
	thickness of the pulley rim	$T_{rim} = 2.41$ to 3.625 mm for drive	varies from $\frac{D}{300} + 2 \text{ mm}$ to $\frac{D}{200} + 3 \text{ mm}$ for single belt
		$T_{rim} = 2.41$ to 3.625 mm for drive	
	Number of arm	No need arm	The pulleys less than 200 mm diameter are made with solid disc instead of arms. The thickness of the solid web is taken equal to the thickness of rim measured at the centre of the pulley face.
	Diameter of hub	$d_1 = 115$ mm (for drive pulley shaft)	$1.5 d + 25 \text{ mm}$, $d =$ diameter of shaft
$d_2 =$			
Length of hub	$L = 95$ mm for drive pulley	$\pi/2 * d$, $d =$ diameter of shaft	
	$L =$ mm for driven pulley		

5.5. Structural Support Design

Assemble of all component as follows

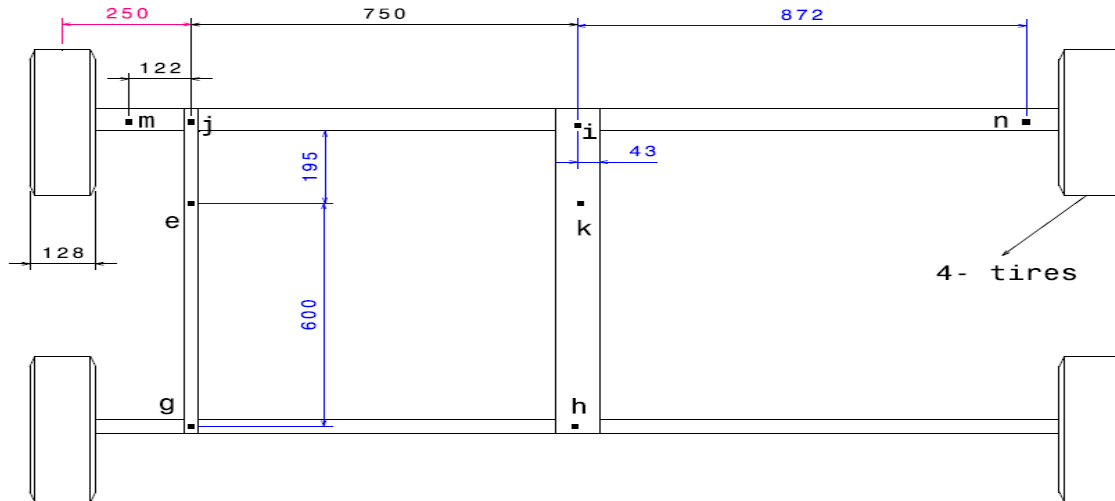

Figure 5. 19 Assemble of structural support

Design of Each Part

1) For Beam j-e-g

Point 'e' and 'g' as we see on following free body diagrams are location of truss EF and E'F' respectively. Vertical force for each truss also described as $F_e = 2.43 \text{ kN}$ and $F_g = 0.848 \text{ kN}$. Reaction force at support point 'g' and 'j' are $F_{Rg} = 1.511 \text{ kN}$ and $F_{Rj} = 1.767 \text{ kN}$. Maximum bending moment take place at point 'e' which equal to $M_{\max} = 0.3976 \text{ kNm}$. For mild steel material and factor of safety ($F.s = 2$) two, the cross-section area becomes $a \times b = 27 \times 27 \text{ mm}^2$.

Free body diagram as follows

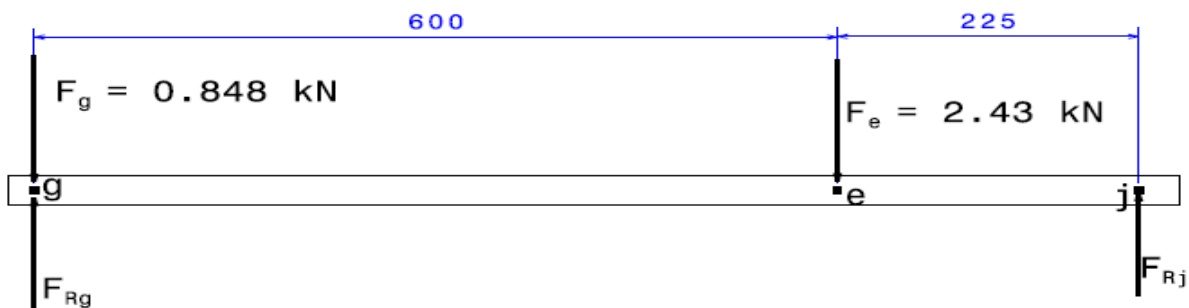

2) For Beam h-k-i

Free body diagram

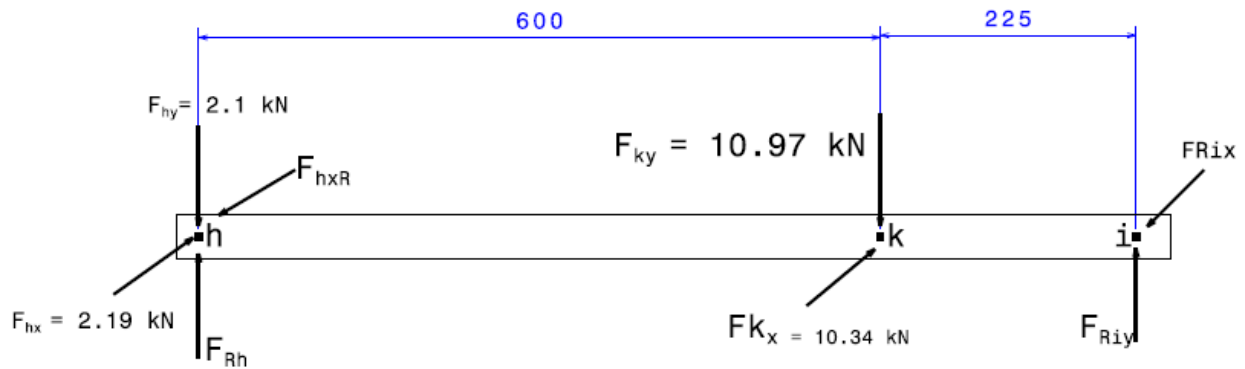

Reaction force at 'h' and 'i' are

$$F_{hxR} = 5.01 \text{ kN}$$

$$F_{Rh} = 5.09 \text{ kN}$$

$$F_{Rix} = 7.52 \text{ kN}$$

$$F_{Riy} = 7.98 \text{ kN}$$

Maximum bending moment for both direction occurred at point 'k' and their values are $M_x = 1.7$ kNm, $M_y = 1.8$ kNm and $M_{tot} = \sqrt{M_y^2 + M_x^2} = 2.5$ kNm

Therefore, For mild steel material and factor of safety two (F.S = 2), and let $a = 86$ mm. then $b = 38$ mm.

3) For Beam m-j-i-n

Reaction force at tire have $T_{11x} = 1.823$ kN, $T_{11y} = 6.03$ kN, $T_{12x} = 9.91$ kN, $T_{12y} = 5.07$ kN as direction described on free body diagram below

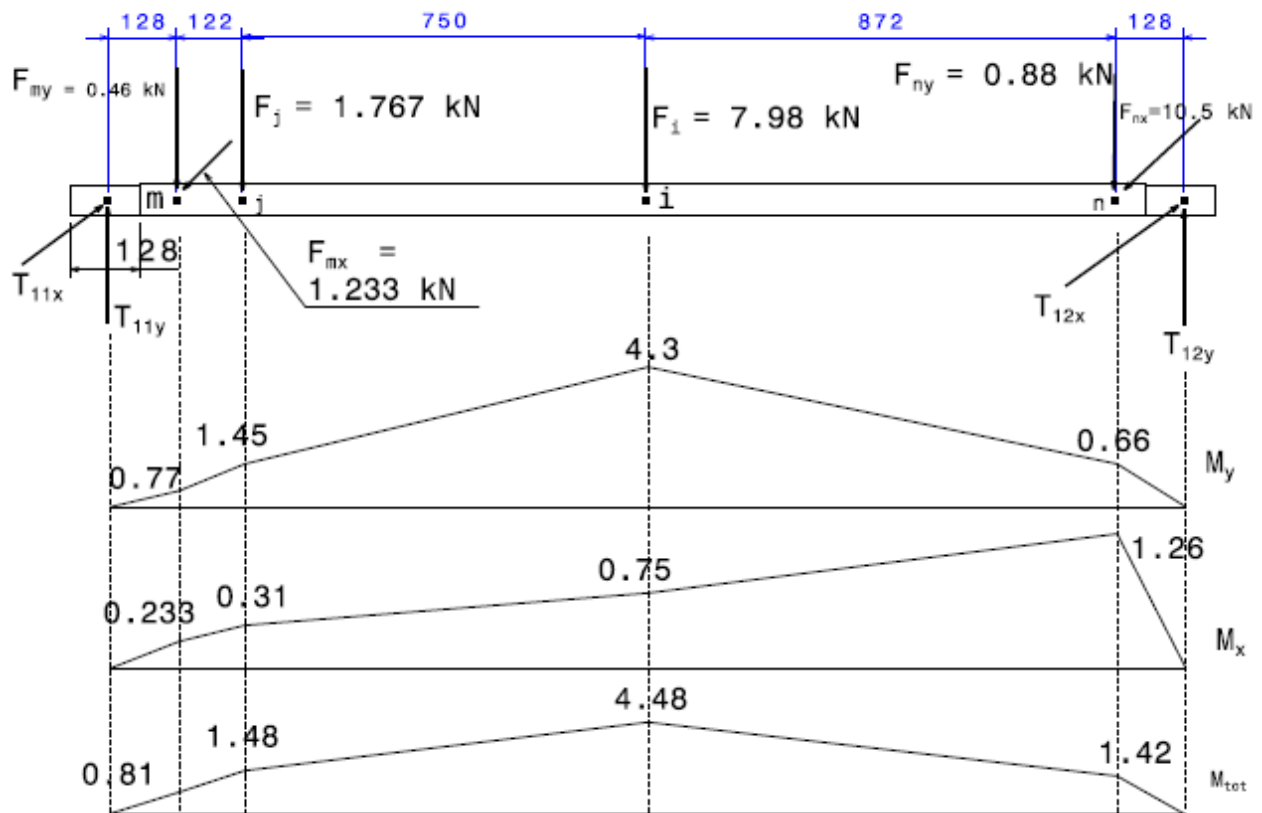

Note: length in mm and moment in kNm unit

Therefore, for mild steel material and F.s (factor of safety) = 2, the cross-section area becomes

$$A = a \times b = 60 \times 60 \text{ mm}^2$$

4) For Beam g-h

Free body diagram :

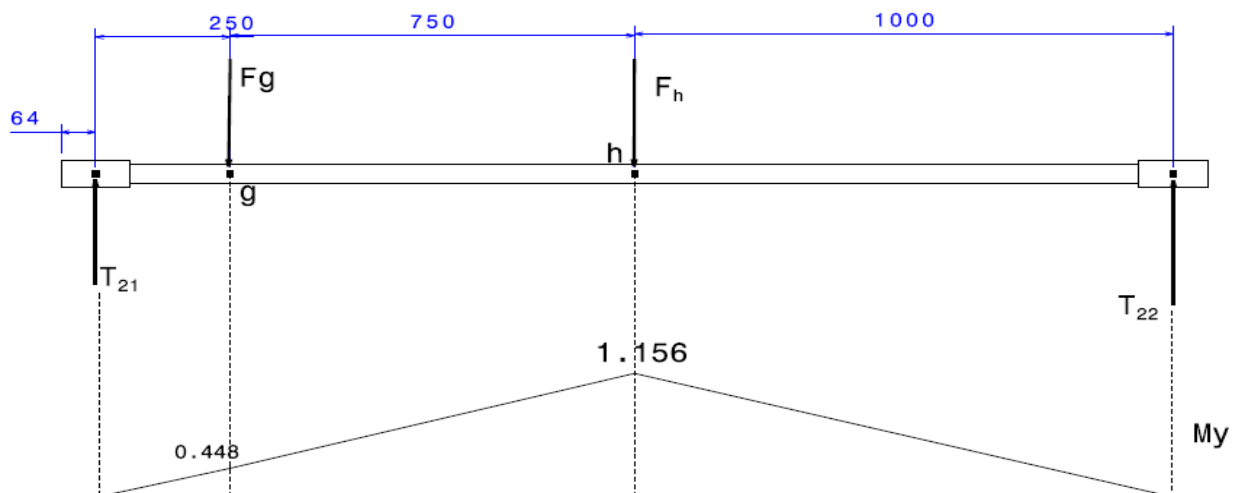

Note : length in mm and moment also in kNm.

Therefore, for mild steel material and F.s (factor of safety) = 2, the cross-section area becomes

$$A = a \times b = 39 \times 39 \text{ mm}^2$$

5.6 Design of traction connection component

Traction Power Need

Traction power need for move machine is the sum of power need for rotate pick up component (P_p), power for conveyer (P_c) and power loss due to friction between ground and tire (P_f).

- Power loss due to rolling friction between tire and ground depends on the weight of machine.
i.e. $P_f = V * F_{rf} = V * \mu_r * R$

$$P_f = 1.1772 \text{ KW}$$

where $\mu_r = 0.08$ (rolling coefficient of friction range 0.04 to 0.08)

$$R = m_{\text{total}} * g = 14.715 \text{ KN. (} m_{\text{total}} = 1500\text{kg) and } V = 1\text{m/sec}$$

- Power used for rotate pick up part is 7 KW
- power used to conveyer is 3.023 KW

Therefore total power ($P_{\text{total}} = P_c + P_p + P_f = 11.2 \text{ KW}$).

Traction Force

Traction force for pulling the machine :

$$F_{\text{traction}} = P_{\text{total}} / V = 11.2 \text{ KN}$$
 Since velocity of machine is 1m/s

Check either the tire rotate or slide at contact

May the tire can be slide if the slide friction force applied on tire less than the rolling friction force plus force for power transmission for pick up component and conveyer.

Force for slide friction : $R * \mu_s = 12.5 \text{ KN}$ where $\mu_s = 0.85$ is static coefficient of friction.

Force for rolling friction plus force for power transmission for pick up component and conveyer is 8.2 KN.

Therefore, from the above force comparison the tire rotate rather than slide.

Design of Part

The structural composition of the part is as follows:

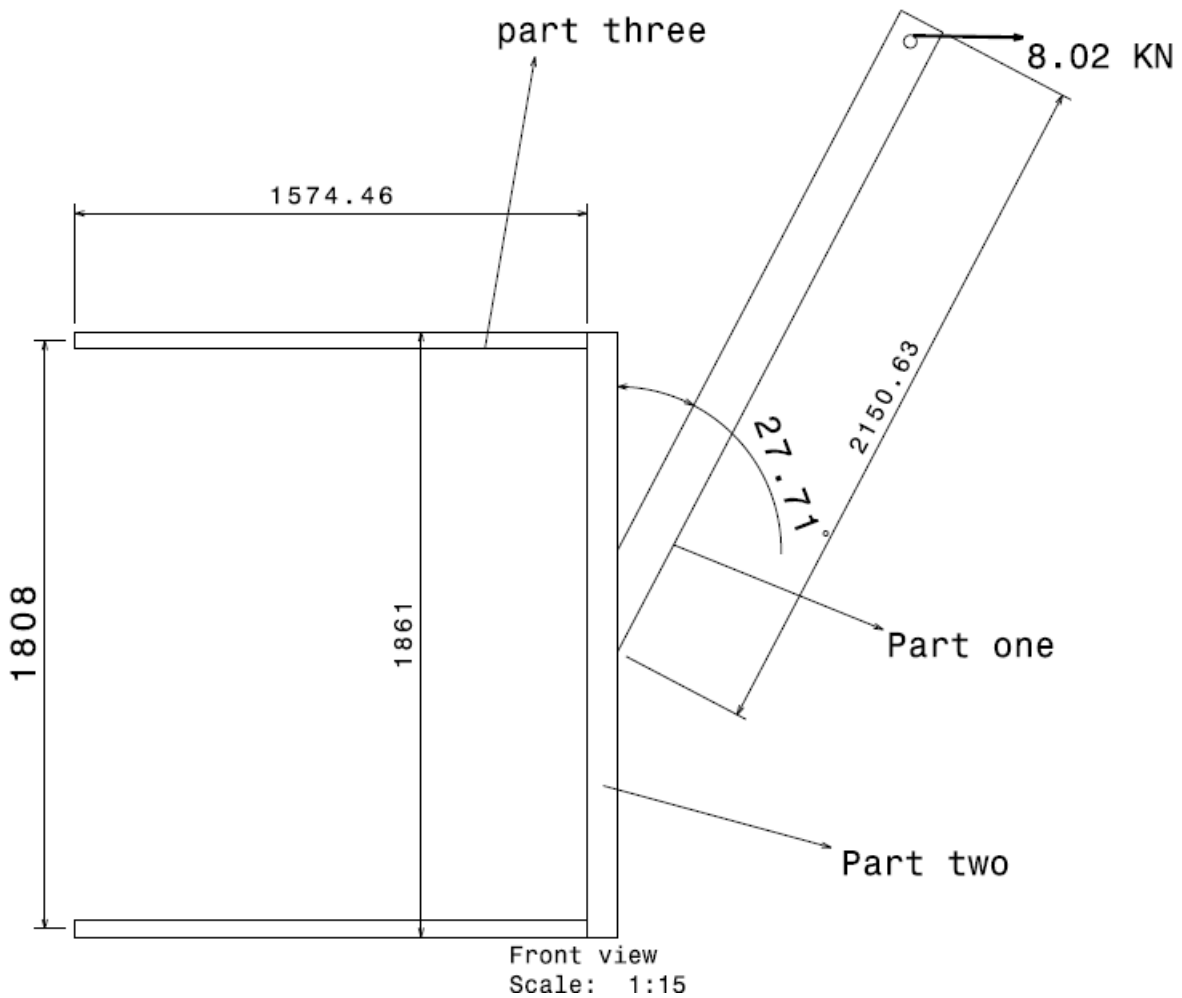

Figure 5. 20 Traction component

Cross section area of each part are designed and summarized as follows:

Part one : $b \times a = 145 \times 145$ mm

Part two : $b \times a = 93 \times 93$ mm

Part three : $b \times a = 53 \times 53$ mm

5.7 Cost Estimation

Cost of analysis include the cost of material, cost of manufacturing, cost of standard materials available in market like bearing, bearing house ,block support and etc and cost of manufacturing.

Manufacturing cost Estimation

✚ working time

- 1) Relaxation (Rest) Allowance: is commonly 5% to 10% (of normal time)
 - ✓ Fatigue allowance: enable the operator to recover from the physiological and psychological effects which occurs due to continuous doing of the work (monotony etc.).
 - ✓ Personal needs allowance: operator to attend to his personal needs (e.g. going to toilet, rest room, etc.).
- 2) Process Allowance: to compensate for enforced idleness of the worker. Generally 5% of the normal time is provided
- 3) Interference Allowance: when one worker is working on several machines.
- 4) Contingency Allowance: delays (e.g. waiting for raw materials, tools). Contingency allowance is 5% (maximum) or Normal Time.

Therefore, working time = normal time + 20% of normal time, for no interference allowances.

✚ Labor cost

Then cost for labor = salary per 30 days X working time per 8hr

✚ Cost of power

The cost of power consumed in arc welding can be calculated from the following formula: cost

$$\text{power} = \frac{V \cdot A}{1000} + \frac{t}{60} + C$$

A = Current in Amperes

t = Normal time in minutes

C = Cost of electricity per kWh i.e. Unit.

The summary of the cost as follows:

Note: material cost is the direct cost for row material and manufacturing cost is including the cost of labor, cost for power and machine.

No.	Material name	quantity	Cost estimation		
			Material	Manufacturing	Total
1	Tire	4	12000	-	12000
2	Pickup finger	60	108	500	608
3	Spring	60	1200	-	1200
4	spring support road	60	75	1500	1575
5	Main shaft in belt load	1	144	25	169
6	Main shaft in non belt load	1	56	25	81
7	Shaft rod	6	750	200	975
8	Shaft rod support	2	180	75	255
9	Enclosing cylinder	1	576	50	626
10	Pick up support and forage taker from pick up	2	972	300	1272
11	Feed-dosing apparatus (casing)	1	486	25	511
13	Power transmission belt	2	750	-	750
14	Drive shaft and its component	1	180	30	210
15	Pulley	4	1300	-	1300
14	Beam at front tire	1	1080	50	1130
15	Beam at rare tire	1	540	50	590
16	Beam G-E-C	1	90	31	121
17	Beam H-I-J	1	414	31	445
18	Conveyor pulley	2	1400	-	1400
19	Conveyor Belt	1	2040	-	2040
20	Pushing rod and its component	34	1224	200	1424
21	Cord support of conveyor	2	800	150	950
22	Truss	2	1080	100	1180
23	Casing		1458	50	1508
24	Block support	2	180	50	230
25	Rod resist forage return over head of pulley	1	36	25	61
26	Chute	1	558	25	583
TOTAL SUM			29677	3492	33167

Chapter six: Finite element analysis of main component

6.1. Analysis of pick up support in belt power transmission side.

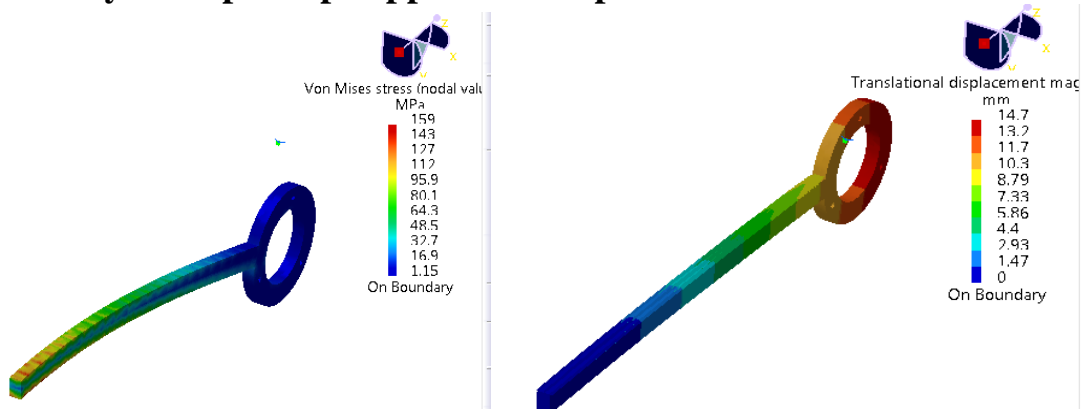

Result:

a. von mises stress (nodal value)

- maximum stress - 159 Mpa
- Minimum stress - 1.15 Mpa
- factor of safety : 1.57

b. translation displacement magnitude on boundary

- Maximum displacement: 14.7 mm
- Minimum displacement : 0 mm

Modification

There are some reasons for modification

- Since the clearance between ground and pick up finger is 2 mm, the deformation must be less than 2mm
- during the machine on motion, vibration effect may bring more deformation

Way of modification

- using truss support which used to support picked material and also pick up finger component.

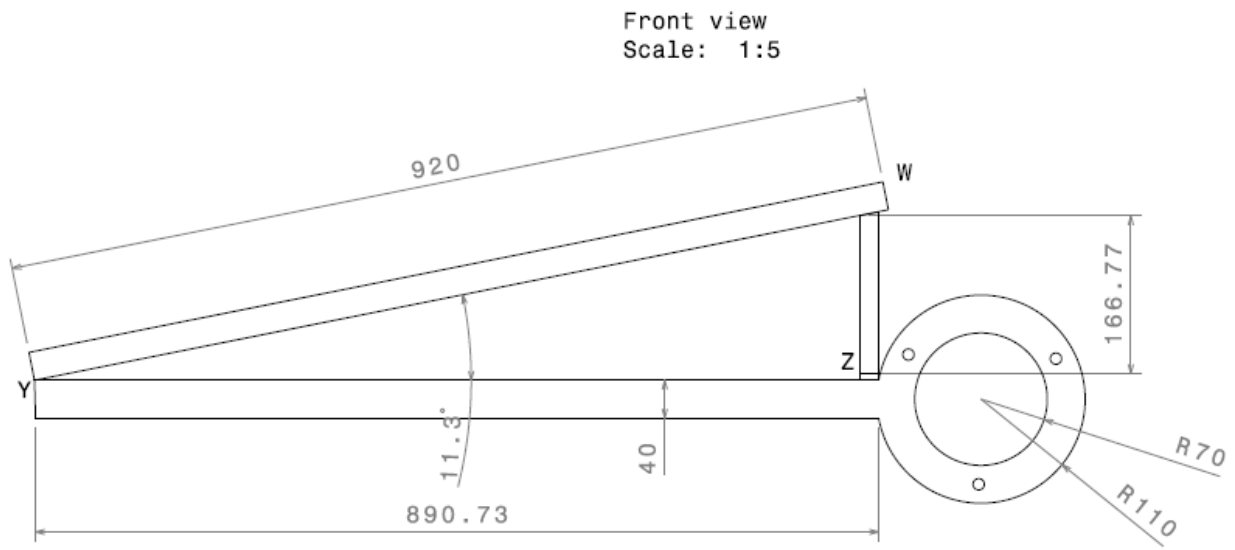

c. modified pick up component support

Cross section of truss ZW = 7 X7 mm² and YW has 7 x 90 mm.

After modification the analysis result as follows

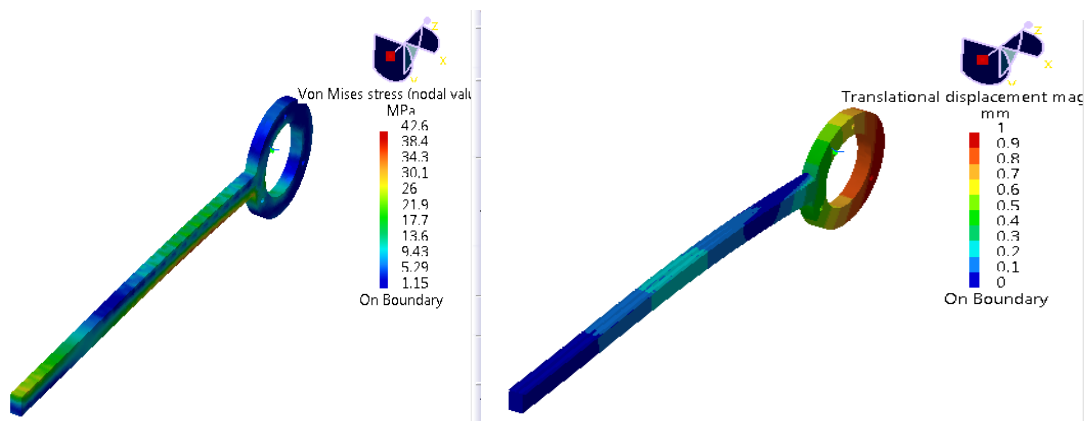

d. von mises stress (nodal value) e. translation displacement magnitude on boundary

Note: for pick up finger in non belt load side also the truss which has same area and geometric construction as above

6.2. chord of bucket analysis

✚ Chord analysis in belt transmission load side

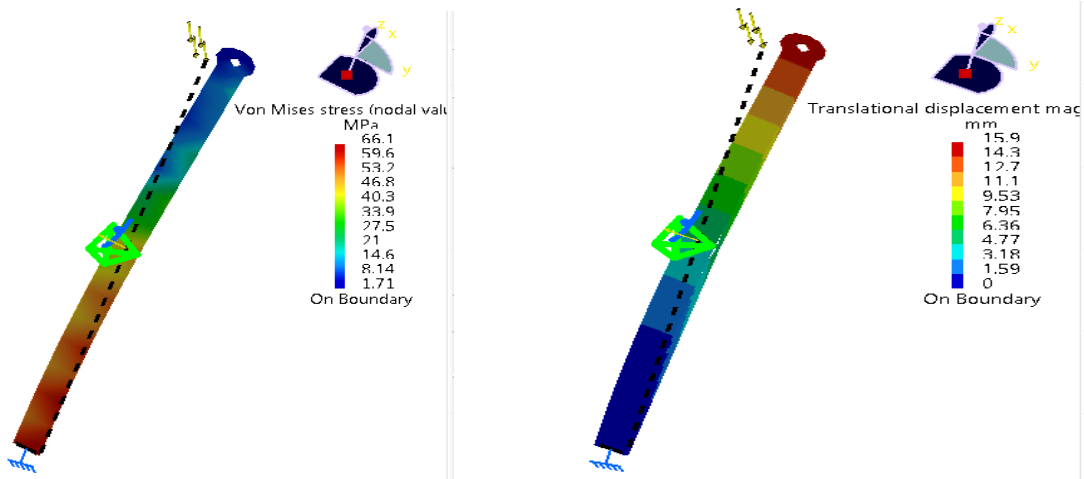

a. von mises stress (nodal value)

max. stress = 66.1 Mpa

min. stress = 1.71Mpa

factor safety = 3.8

b. translation displacement magnitude on boundary

max deformation = 15.9 mm

min deformation = 0

✚ Chord analysis in non belt transmission load side

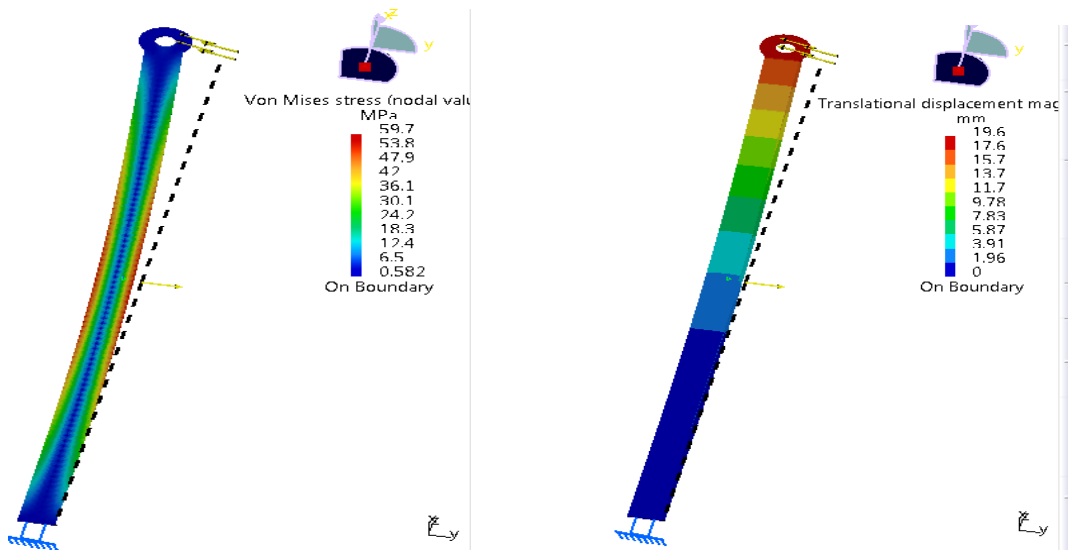

a. von mises stress (nodal value)

max. stress = 59.7 Mpa

min. stress = 0.581 Mpa

Factor of safety =4.2

b. translation displacement magnitude on boundary

max deformation = 19.6 mm

min deformation = 0

6.3. Truss analysis

✚ truss support in belt load side

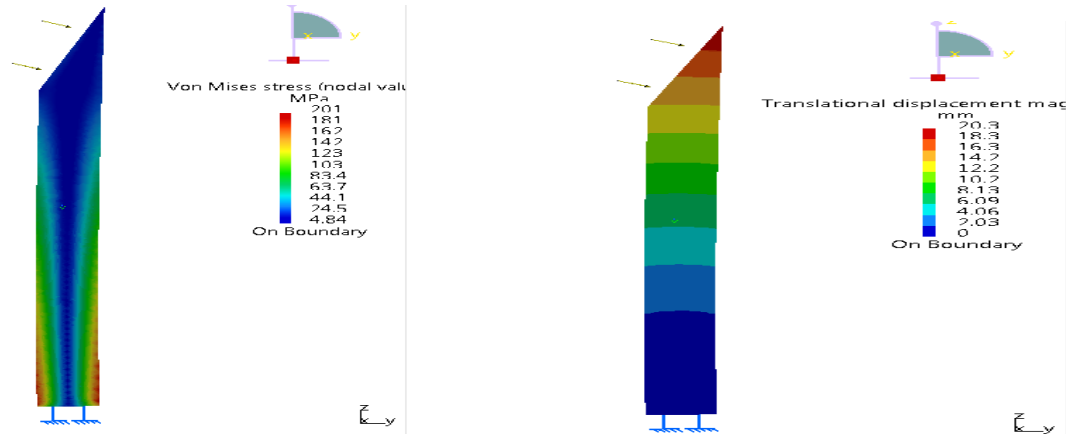

Result

a. von mises stress (nodal value)

max. stress = 201 Mpa

min. stress = 4.84 Mpa

factor safety = 1.23

b. translation displacement magnitude on boundary

max deformation = 20.3 mm

min deformation = 0

✚ truss analysis in non belt load side

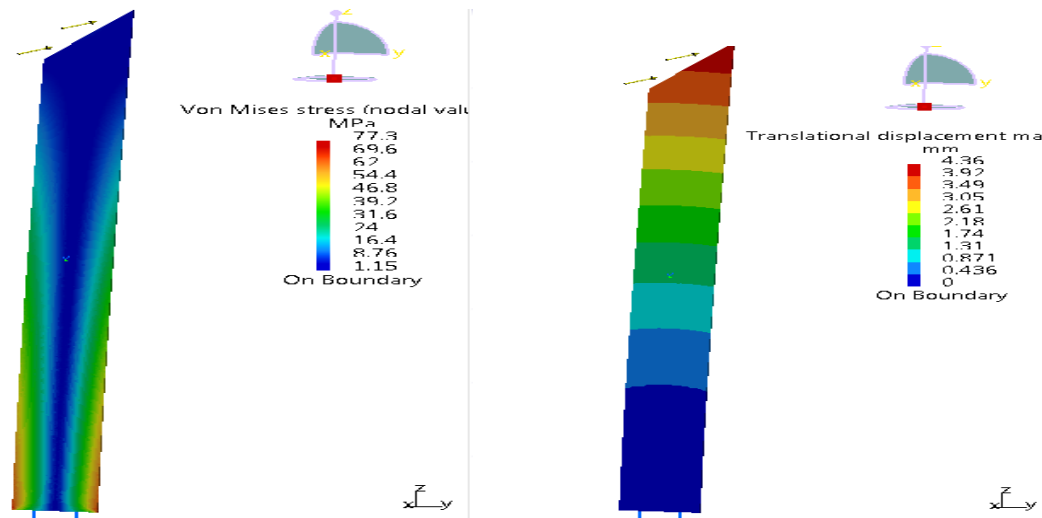

Result:

a) von mises stress (nodal value)

max. stress = 77.3 Mpa

min. stress = 1.15 Mpa

factor safety = 3.2

b translation displacement magnitude on boundary

max deformation = 15.9 mm

min deformation = 0

6.4. Block Analysis

✚ for block support in belt power transmission load side

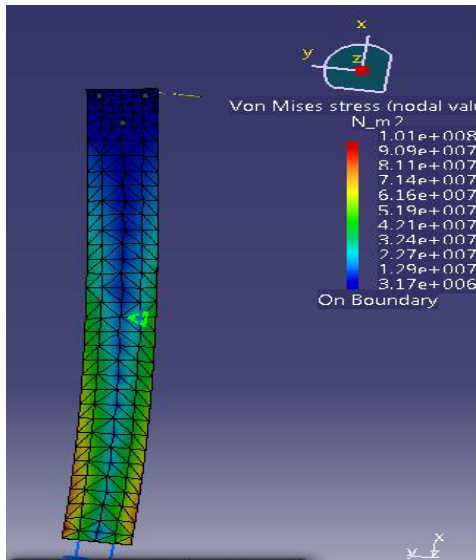

a. von mises stress (nodal value)

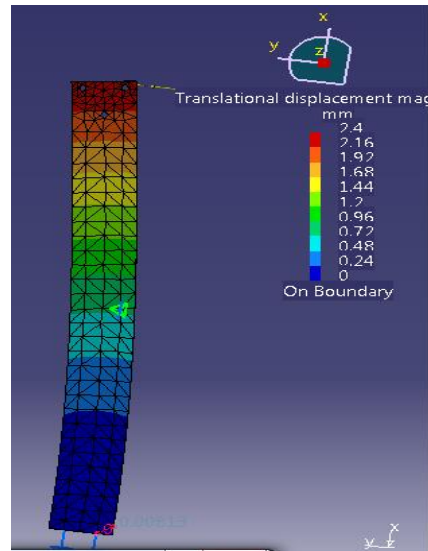

b. translation displacement magnitude on boundary

Maximum stress 101 Mpa and Factor of safety (F.S) becomes 2.5. Maximum displacement at tip is 2.4 mm

✚ For block support in non belt power transmission load side

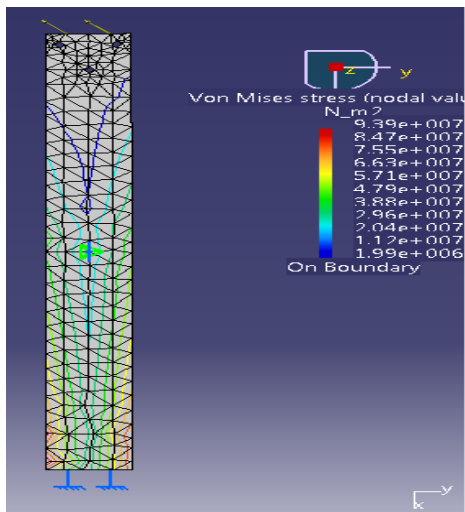

a. von mises stress (nodal value)

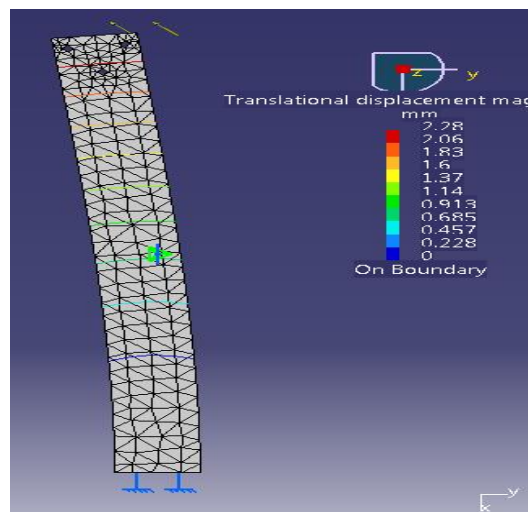

b. translation displacement magnitude on boundary

maximum stress takes place at joined(restraint) and its value 93.8 Mpa and factor of safety $250/93.8 = 2.7$. Maximum displacement applied at force application tips which is 2.28mm.

6.5. Analysis of structure component

Analysis of Beam on Front Tire

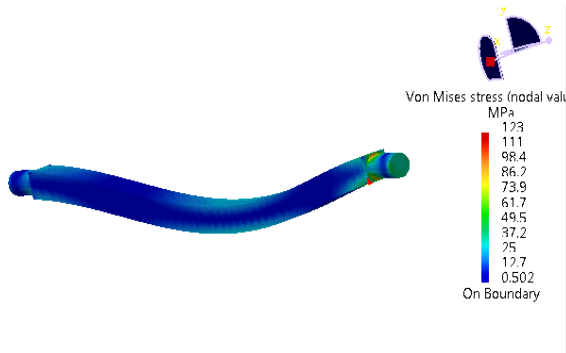

a. von mises stress (nodal value)

- max. stress = 123 Mpa
- min. stress = 0.502 Mpa
- factor safety = 2

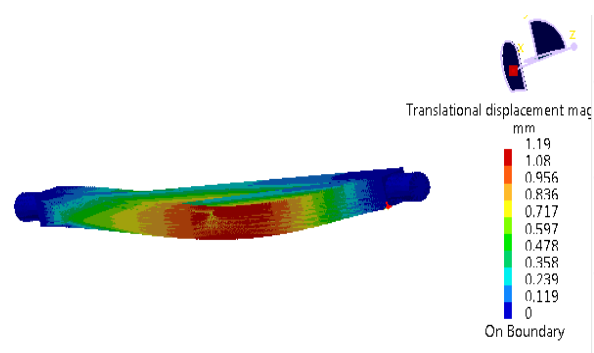

b. translation displacement magnitude on boundary

- max deformation = 1.19 mm
- min deformation = 0

Analysis of Beam at Rare Tire

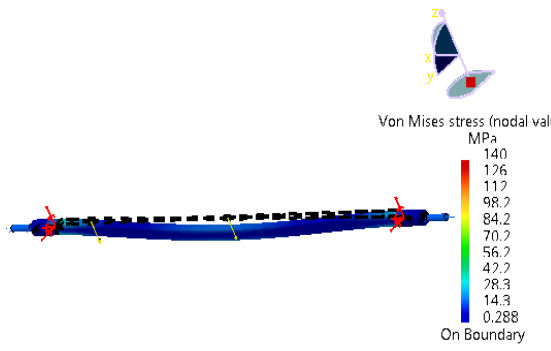

a. von mises stress (nodal value)

- max. stress = 140 Mpa
- min. stress = 0.288 Mpa
- factor safety = 1.8

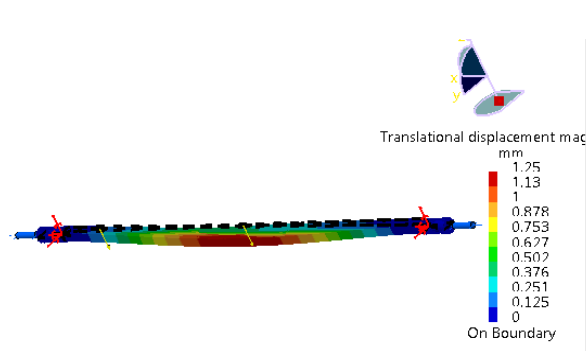

b. translation displacement magnitude on boundary

- max deformation = 1.25 mm
- min deformation = 0

Analysis For Beam g-e-j

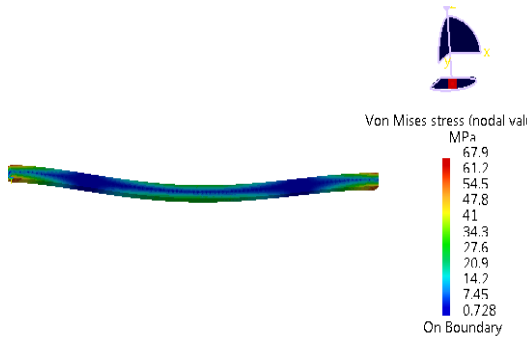

a. von mises stress (nodal value)

- max. stress = 67.9 Mpa
- min. stress = 40.728 Mpa
- factor safety = 3.7

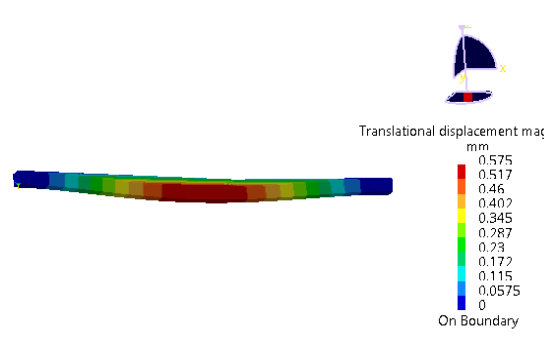

b. translation displacement magnitude on boundary

- max deformation = 0.575 mm
- min deformation = 0

Analysis For Beam k-h-i

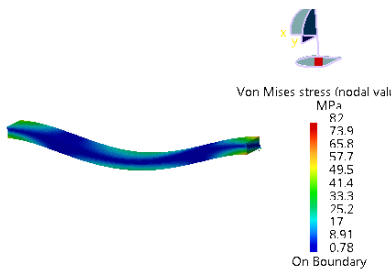

a. von mises stress (nodal value)

- max. stress = 201 Mpa
- min. stress = 4.84 Mpa
- factor safety = 1.23

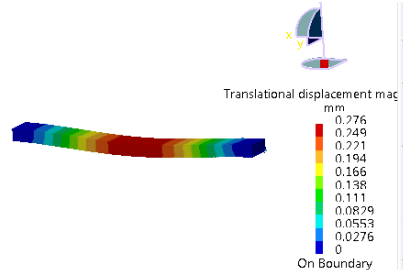

b. translation displacement magnitude on boundary

- max deformation = 20.3 mm
- min deformation = 0

6.9 Analysis of Tractor Connection Part

For Part One and Two

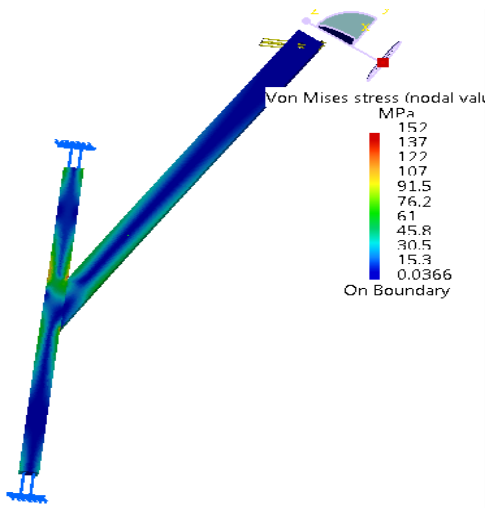

a. von mises stress (nodal value)

- max. stress = 152 Mpa
- min. stress = 0.0366 Mpa
- factor safety = 1.64

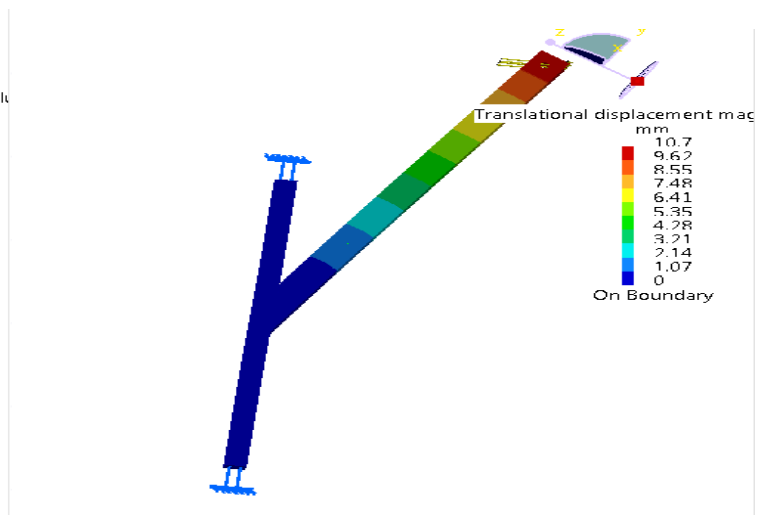

b. translation displacement magnitude on boundary

- max deformation = 10.7 mm
- min deformation = 0

For Part Three

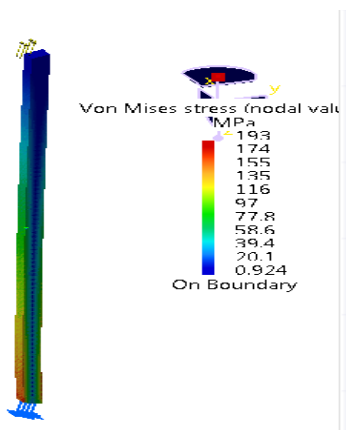

a. a. von mises stress (nodal value)

- max. stress = 193 Mpa
- min. stress = 0.024 Mpa
- factor safety = 1.3

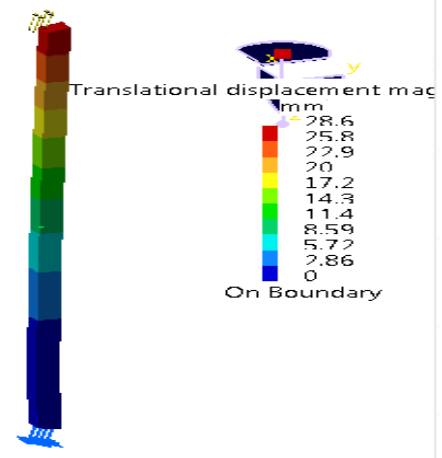

b. translation displacement magnitude on boundary

- max deformation = 28.6 mm
- min deformation = 0

Chapter seven: Conclusion and Future Work

7.1. Conclusion

The forage harvesting machine used in a world are only applicable for plot surface. Plot surface means the surface which has high smoothness. That means to use such machine we have to be prepare forage land with smooth surface or forage land must be plot surface in nature.

To solve above problem the designed machine in this paper (pick up and transfer windrowed forage to trailer) has ability self adjustment with spring compression when force on pick up finger start to be greater than 10N. Ability it compressed may vary up to 180 mm i.e. it may work surface of land which contain 150mm height from valley to pick.

Windrowed forage pick up and transfer to trailer machine is designed the way it may manufactured in country by using most part joined in weld and bolt connection. Also Most part of the machine designed from a material which available in country i.e. mild steel is a material used for most part. Geometric shape of each part can be manufactured simply in small work shop which can produce rectangular and circular surface finish.

After fully manufacture the machine , the forage picked up by pick up finger and transferred to feed-dosing which have take up finger used to take forage from pick up finger and transferred by its weight to conveyor foot area. the hay or silage collected at foot area of conveyor part is transferred to trailer by using belt -road(finger road attach to belt) which used to pushing the forage and discharge to trailer by chute.

The amount of forage picked up and transferred to trailer depend on forward speed of machine since the power and every motion are taken from tire. For the speed of machine(forward speed) is 1 m/sec , the forage to be transferred to trailer is 0.225 m^3 per second.

Total height of machine (height of the forage may transferred in vertical) up to discharge tip of header pulley is 4m But the chute inclined 15° to help forage move to trailer by its weight.

7.2. Future Work

Because of time limitation, this paper does not fully address every information. To keep the machine quality the following work will be need additional attention.

- Find the maximum inclination of working land (forage land slope) to keep the machine from fold down.
- Analyses vibration effect and find the solution if there is effect
- check the tire as it resist all load without fail.
- check either weight balance need. If weight balance needed for this machine find the way it can be solved.
- As analysis of chord get under chapter six, the deformation somewhat high. I think the part may need modification. Therefore, find the way of modification.
- After all above limitation checked the machine can manufactured and test all application
- Find the way the machine can be flexible for other option of traction power source like for horse and any others source.
- Add chopping me

REFERENCE

- 1) Budynas–Nisbett(2006), Shigley’s Mechanical Engineering Design ,Eighth Edition, McGraw–Hill Primis
- 2) R.S. Khurmi, J.k.Gupta (2005) ,text book of machine design, first multicolor edition, eurasia publishing house (pvt.) ltd.
- 3) Ajit K .Strivastava, Caroll E.georing,Roger P .Roharbach, Dennis R.buckmaster(2006), Engineering Principle of Agricultural Machines, Second Edition, ASABE St.Joseph.MI.
- 4) Bill A. stout USACIGR Handbook of Agriculture Engineering Volume III, Texas A&M University, USA
- 5) D.N.Sharma, S. Mukesh, Farm Machinery Design Principles and problems, Second Revised and Enlarged Edition, pusa Agri Books service, India
- 6) Mohsennin , N.N, 1970, Physical properties of plant and animal materials , Breach science publisher, Ney York.
- 7) Sayay (1990), Principle of Agricultural Engineering (2005), volume I , Text book published by Jain Brother, New Delhi, India.
- 8) Jain, S.C and Grace Philip (2002), Farm Machinery an Aproach Text Book Published by Jain Brothers, New Delhi, India.
- 9) Jose M. Dominguez Estupinan and Mekonnen G/slasie, 2003, lecture note of Machine Element and Machine Design, Mekelle University

- 10) Ansel C. Ugural and Saul .k. Fenster, Advanced Strength and Applied Elasticity , Fourth Edition, New Jersey Institute of Technology.
- 11) Siddhartha Ray(Director-in- Charge National Institute of Technical Teachers Training and Research Kolkata), Introduction to Materials Handling, New Age International publisher
- 12) Nigel Cross, Engineering Design Method strategies For Product Design, Third Edition,The Open University, Milton KeyneS, UK
- 13) Jonathan Usborne(2012), an Investigation Into The Relationship Between Tensions in a Slipping Pulley System, University of Bath

- 14) American Society of Agricultural Engineers (ASAE), ASAE Historic Agricultural Engineering Landmarks, World's First Successful Automatic Pickup, Self-Tying Hay and Straw Baler, <http://www.asae.org/awards/historic2/summary.html>
- 15) A. T. Adesogan, associate professor, Department of Animal Sciences; Y. C. Newman, assistant professor, Agronomy Department; Florida Cooperative Extension Service, Institute of Food and Agricultural Sciences, University of Florida, Gainesville, FL 32611.
- 16) *Dipl. Ing. agr Heinz-Günter Gerighausen and Dr. Johannes Thaysen, Moisture content for entire seed heads established by research at Agriculture Canada, Beaverlodge*
- 17): FEED FORWARD PUBLICATIONS, PO Box 578, BENTLEY, West Australia, 6102. E-mail: info@feedforward.com.au. Web: www.feedforward.com.au)

APPENDIX

Appendix A: Assemble

Appendix A-1: Assemble of pick up part before add casing

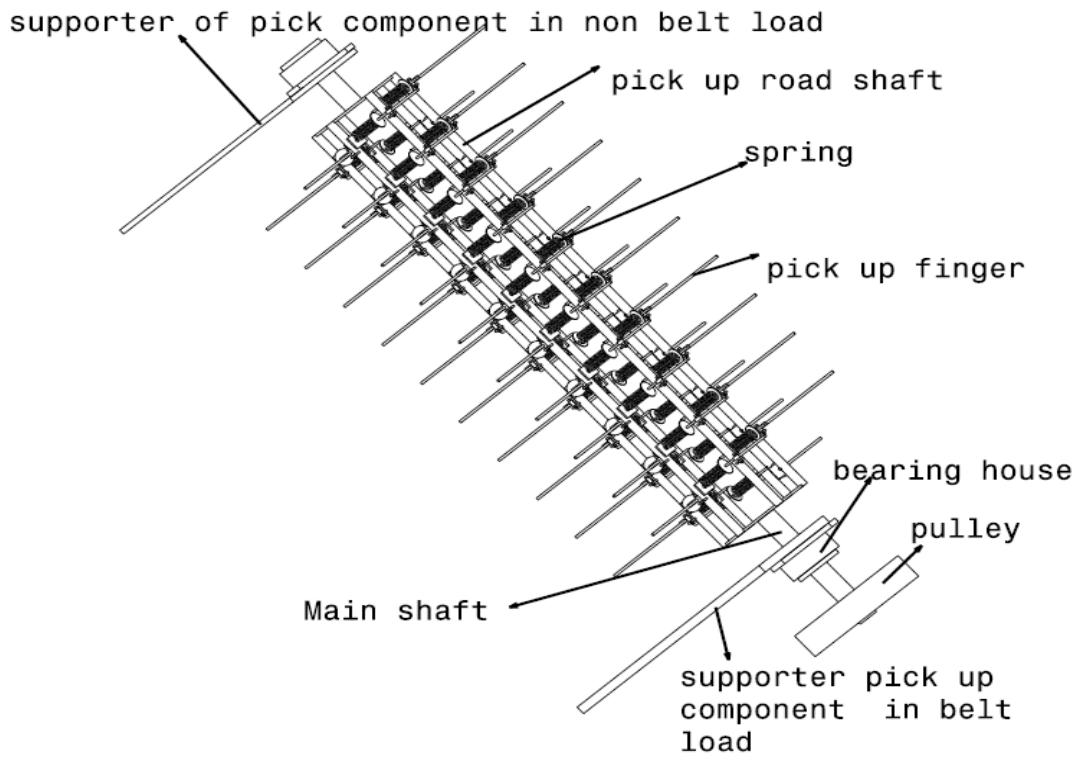

**Appendix A-2: Assemble of pick up part after add casing
(enclosing cylinder, hay dosing)**

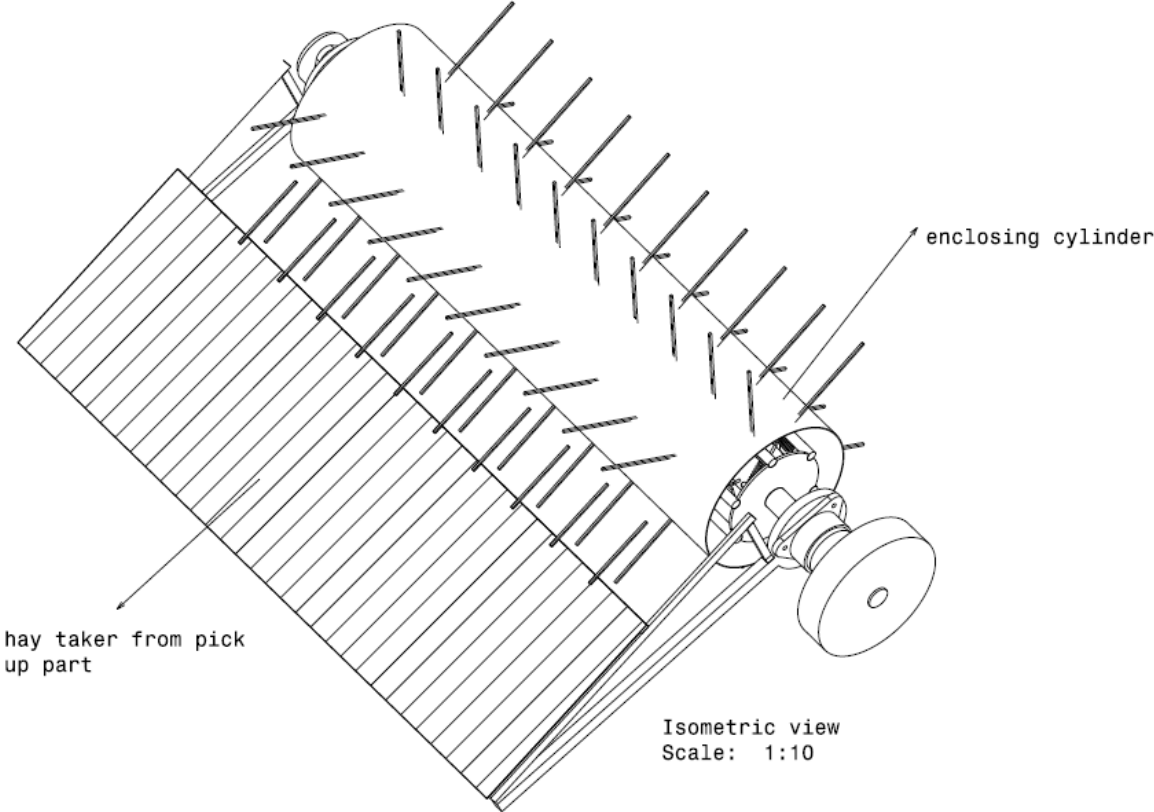

Appendix A-3: Assemble of conveyer part with structural support before add casing

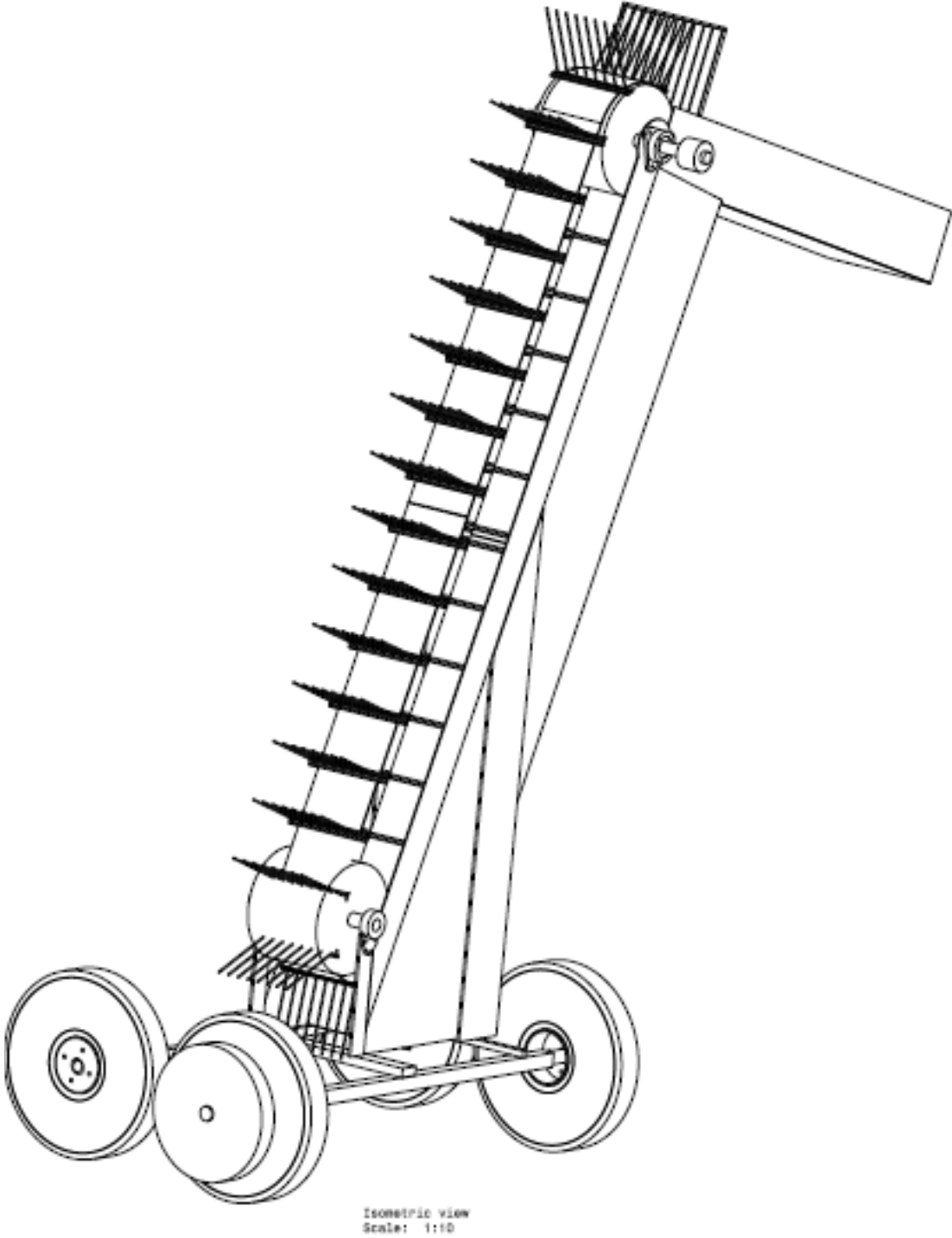

a) 3D of conveyer part

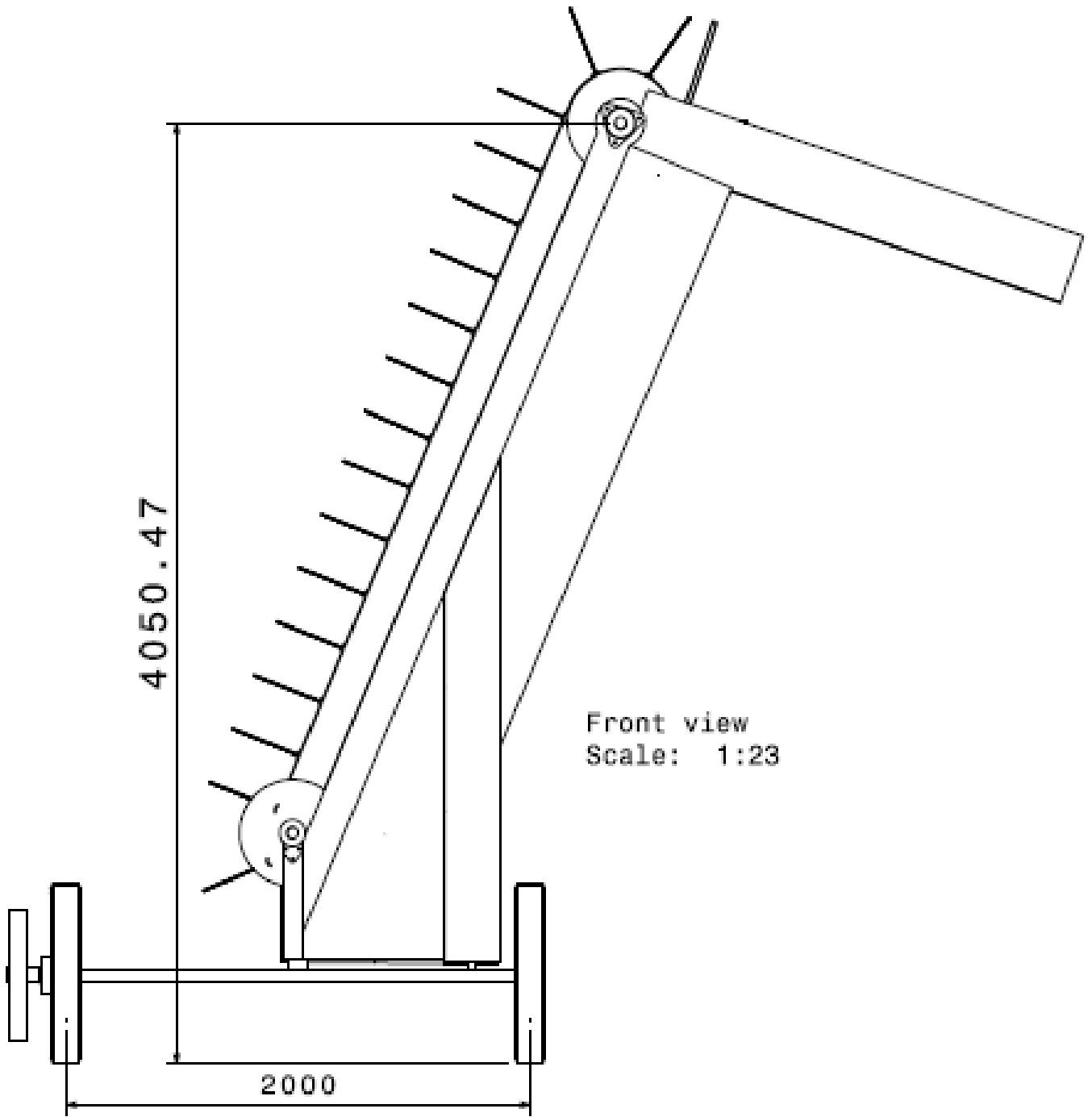

b) 2d of conveyor part

Appendix A-4: over all assemble in 3D

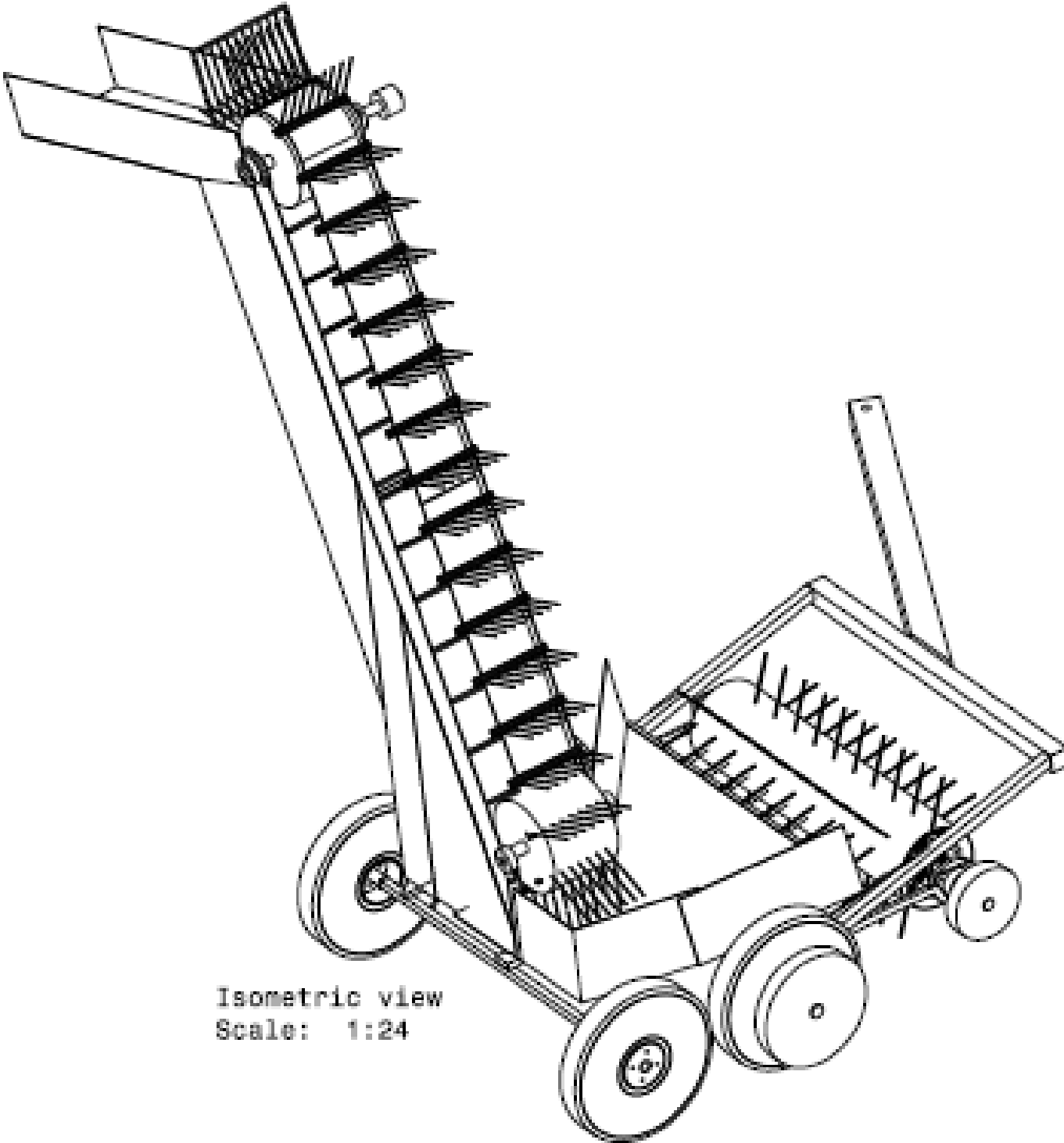

Isometric view
Scale: 1:24

Appendix B: Detail of part

Appendix B-1: Detail of Pick up component

1. pick up shaft rod (shaft rod one)

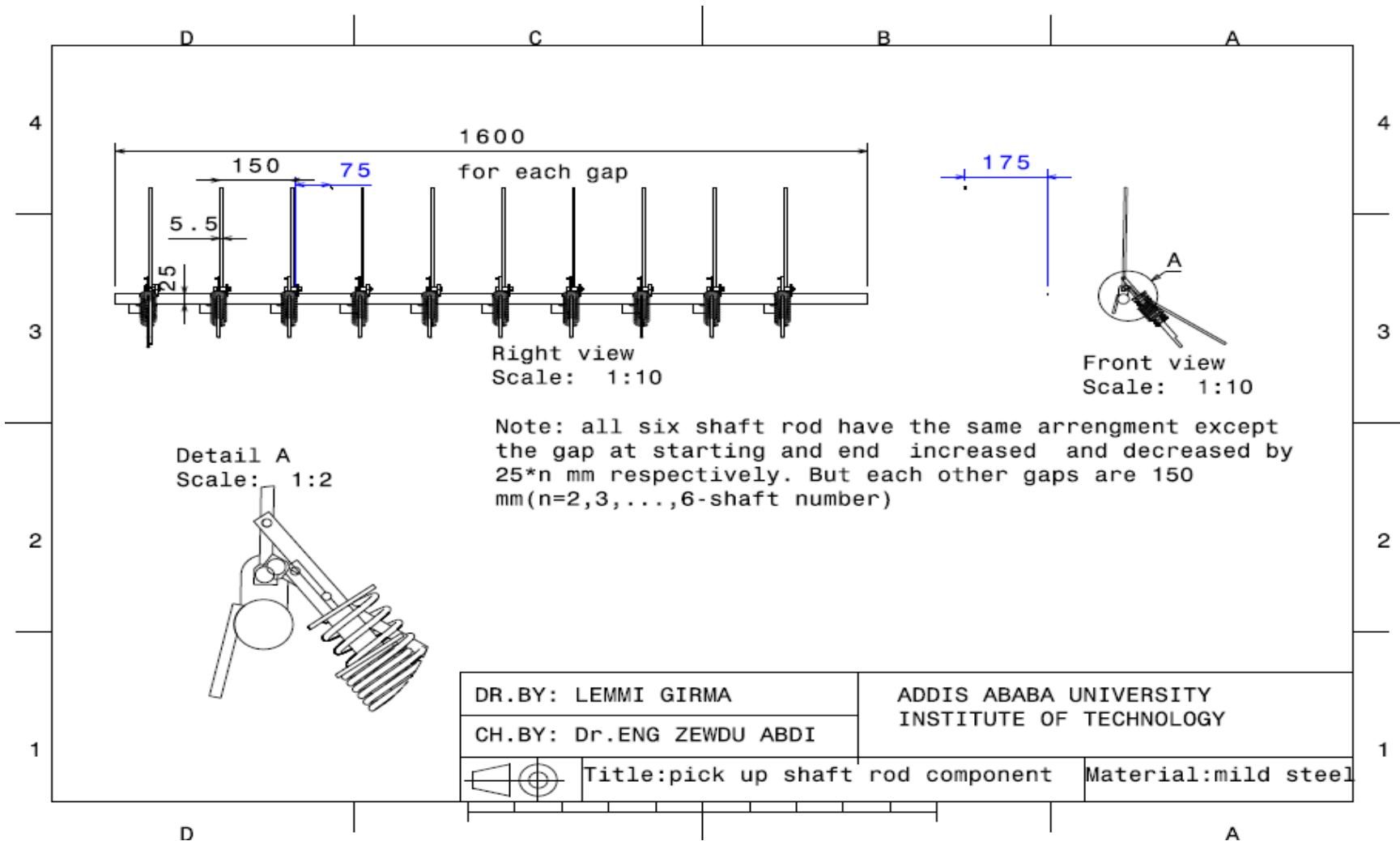

2 . Main shaft in belt load

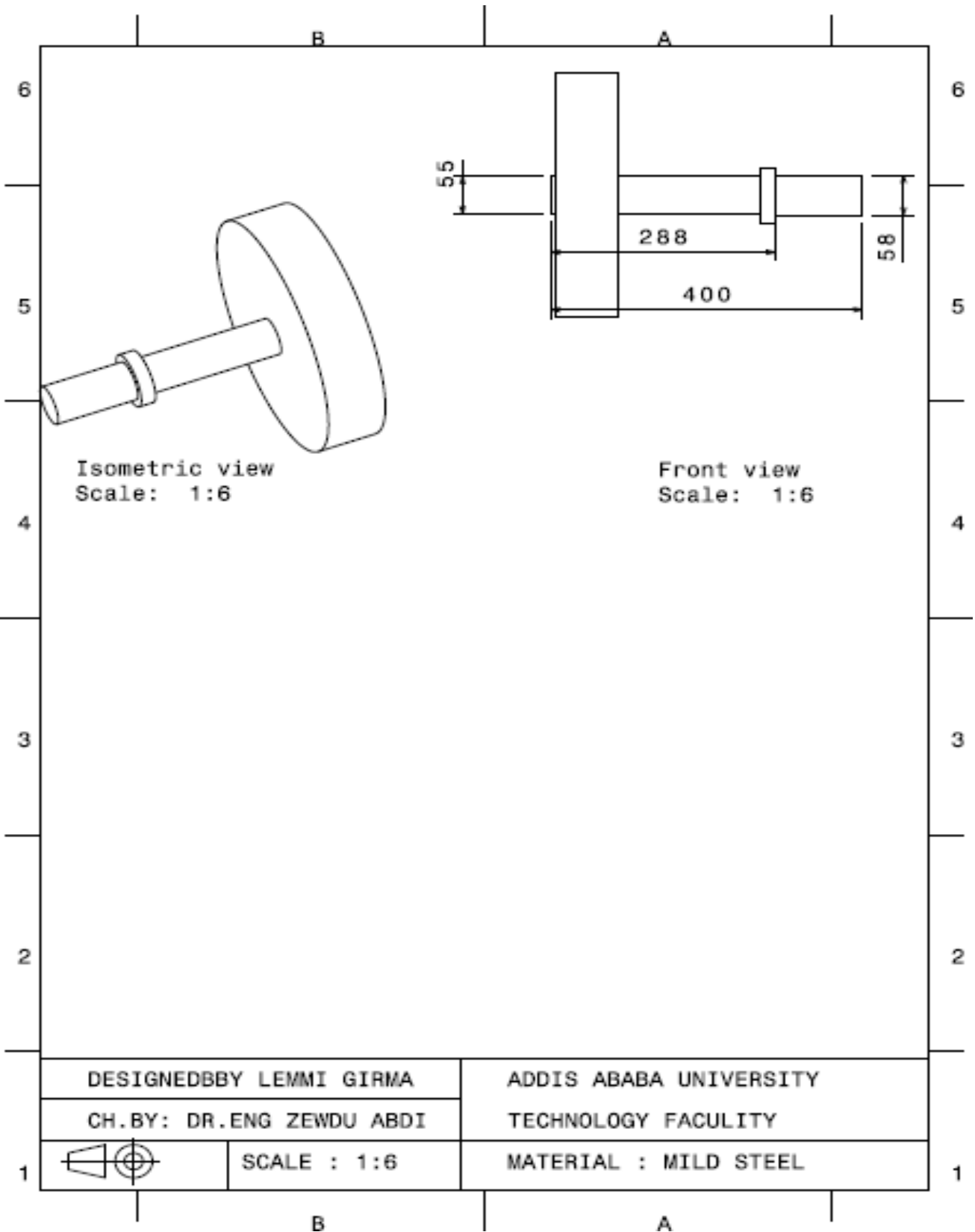

3. Main shaft in no belt load

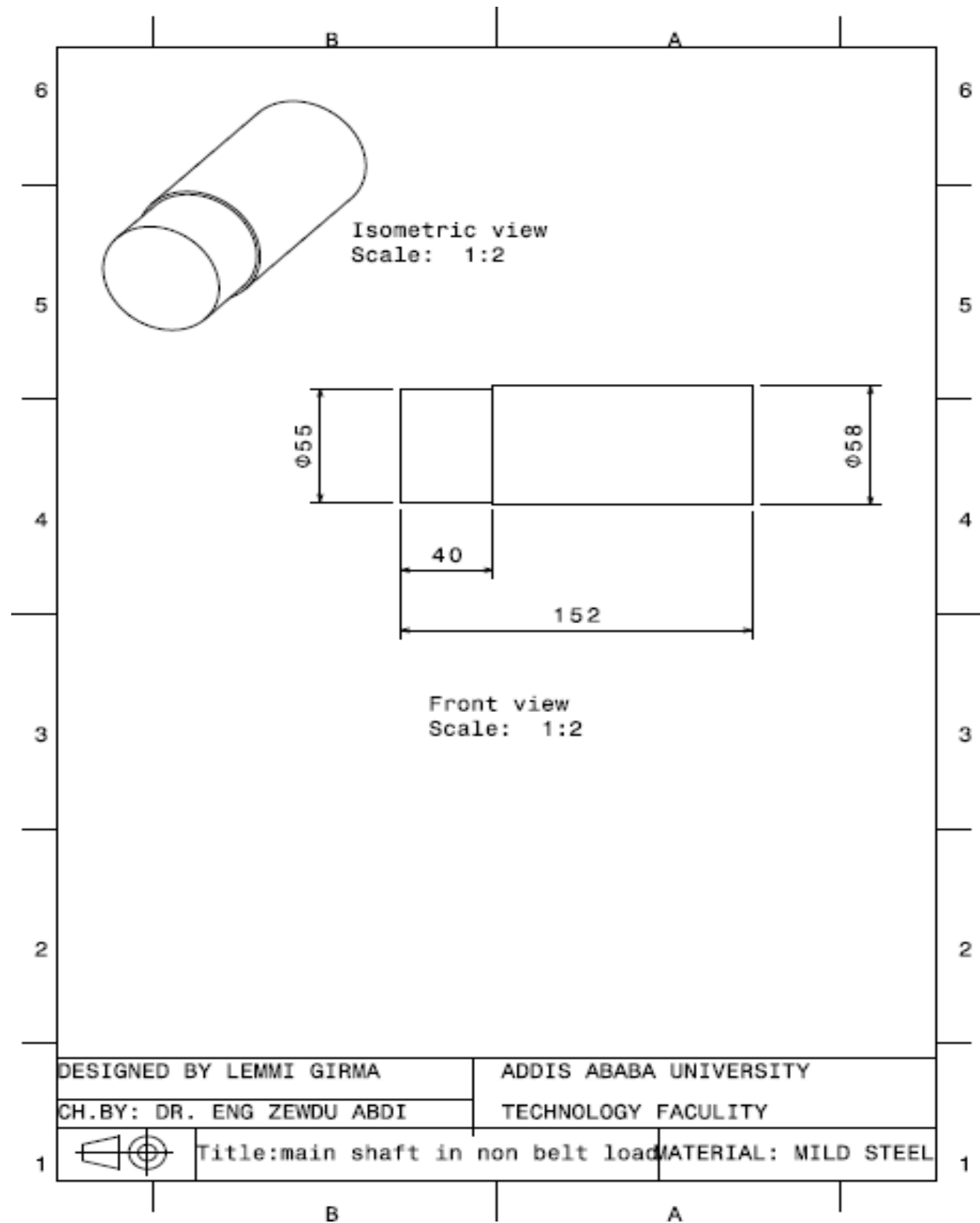

4. Pick up finger

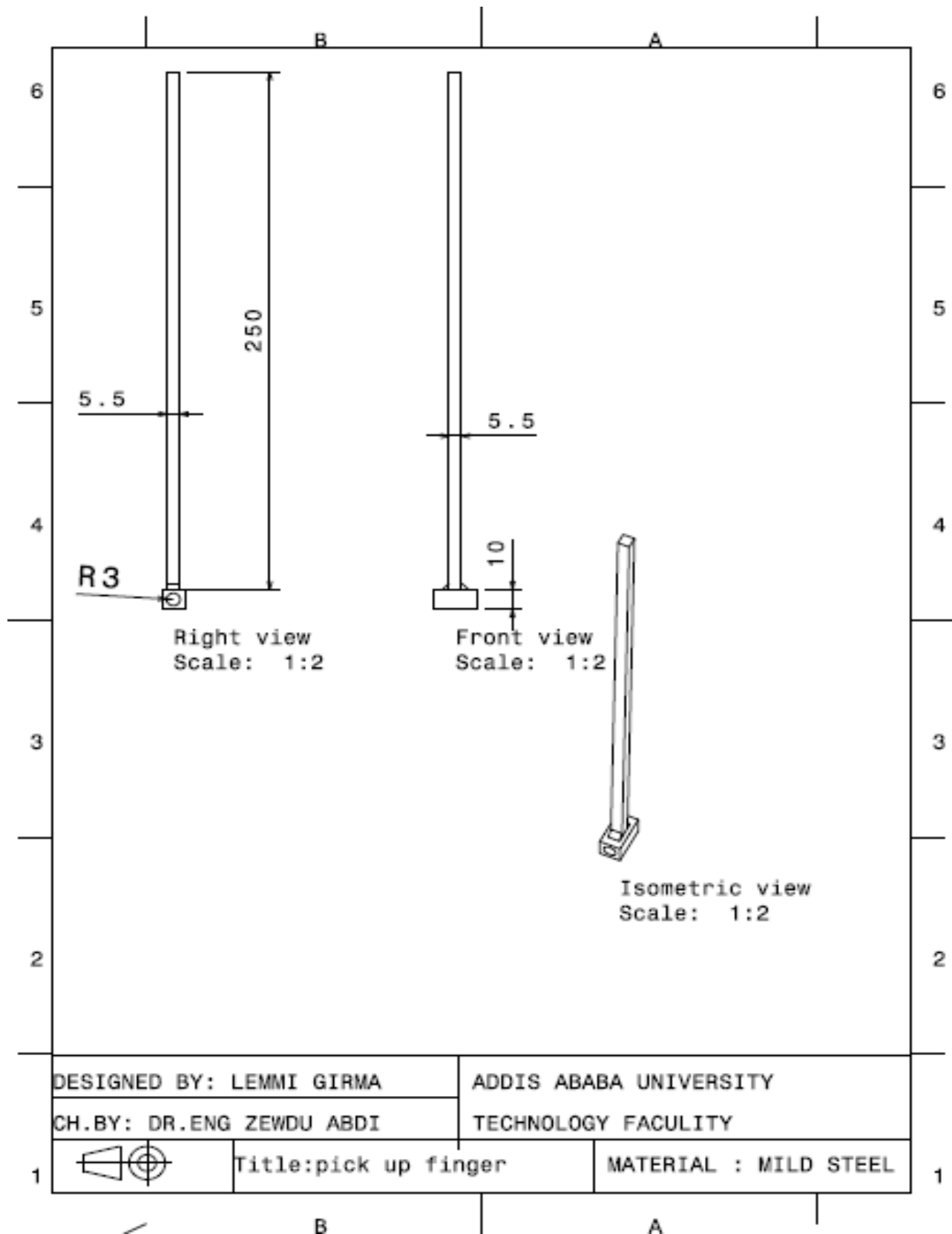

5. Drive shaft which attach to tire

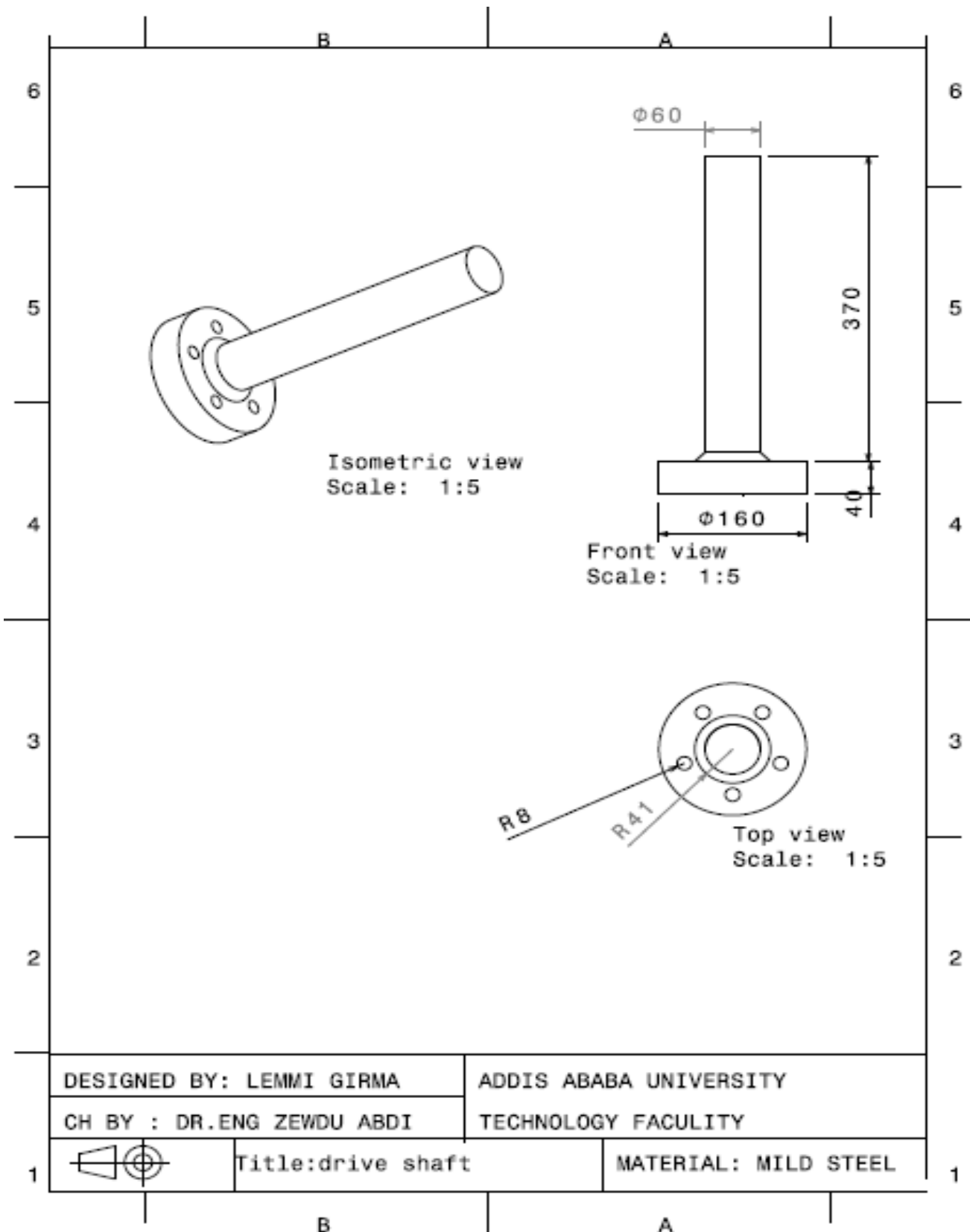

6 . shaft road support

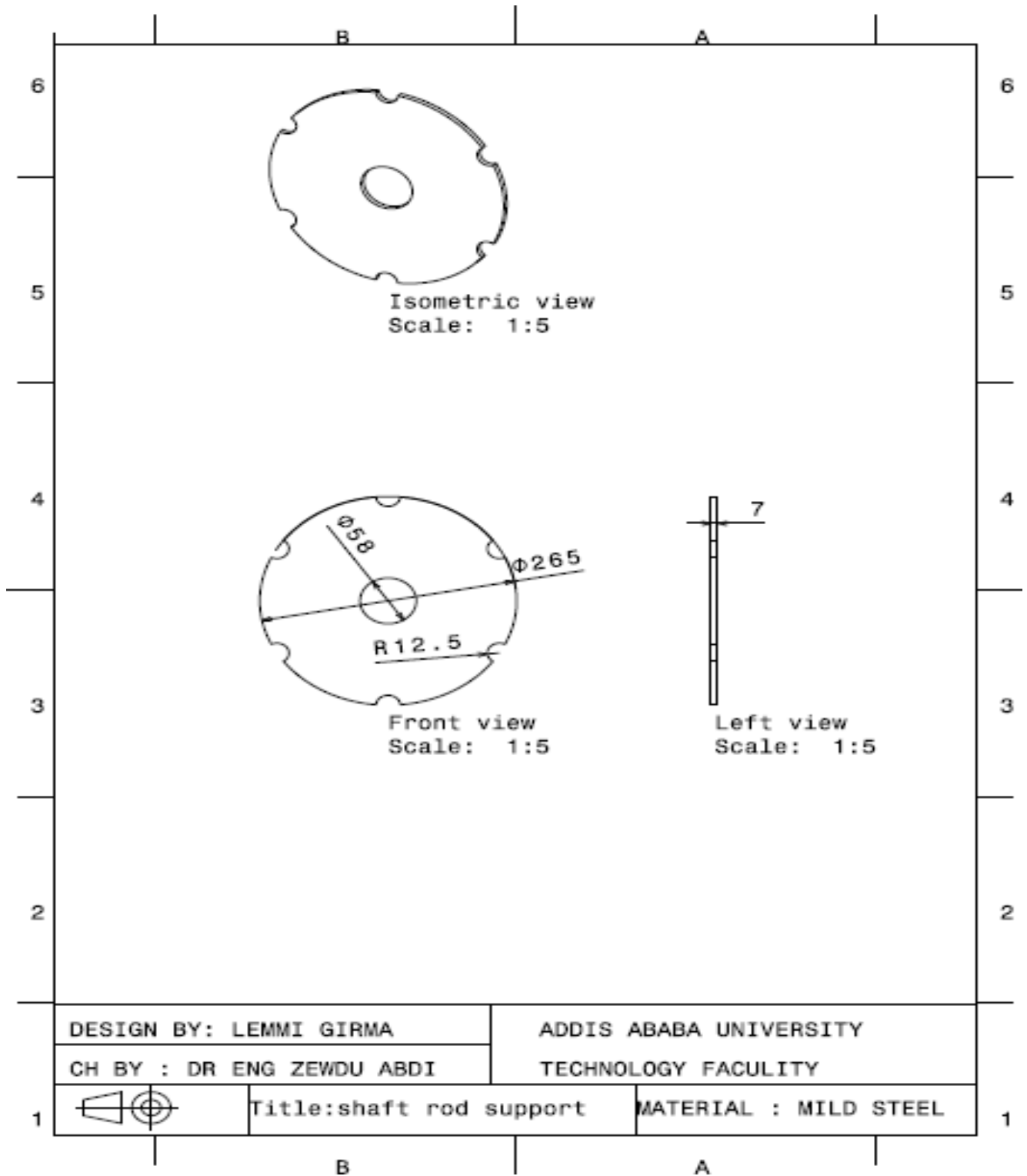

7 . spring component

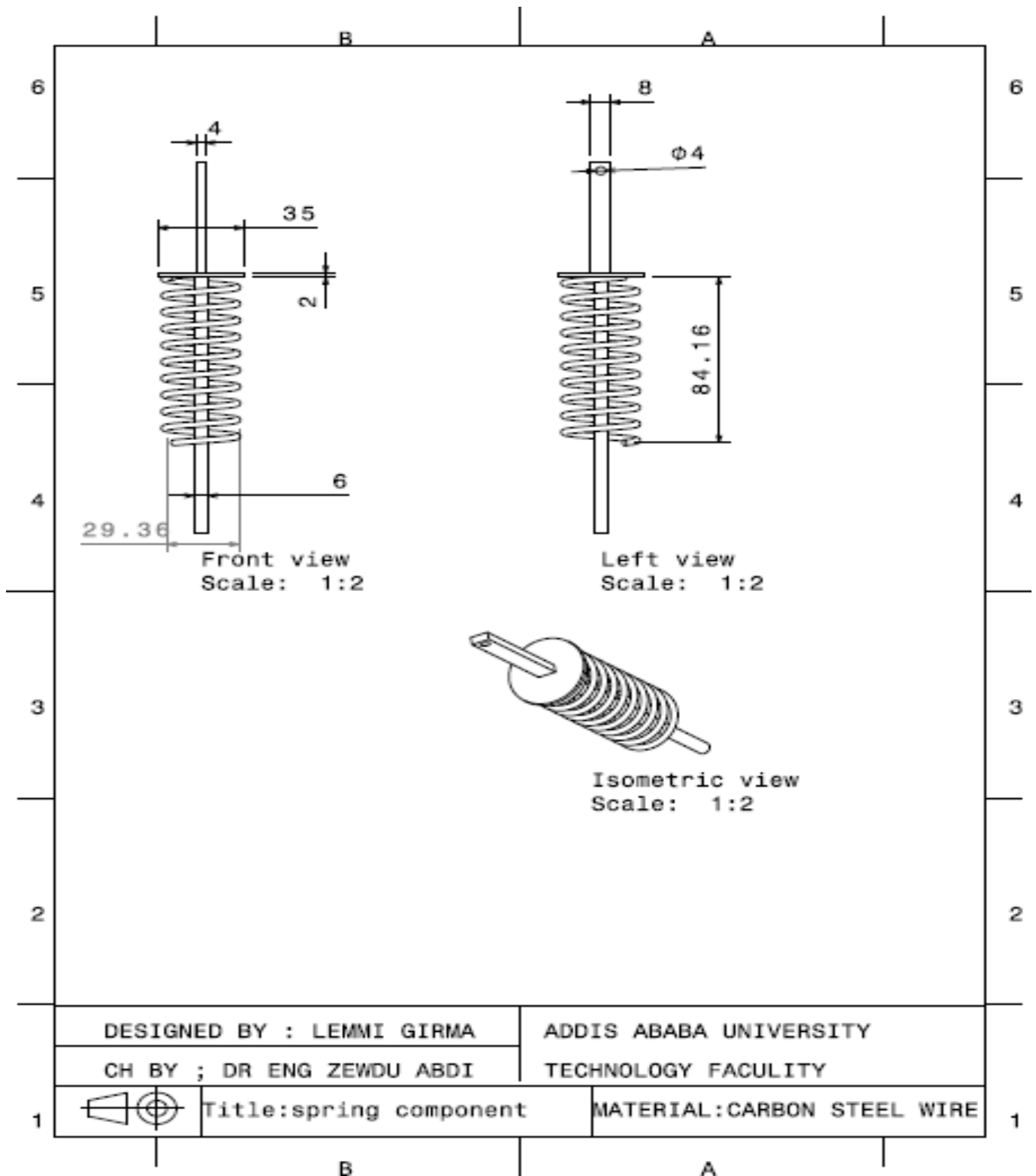

Appendix B-2: Detail of conveyor part

1. chord in non belt load

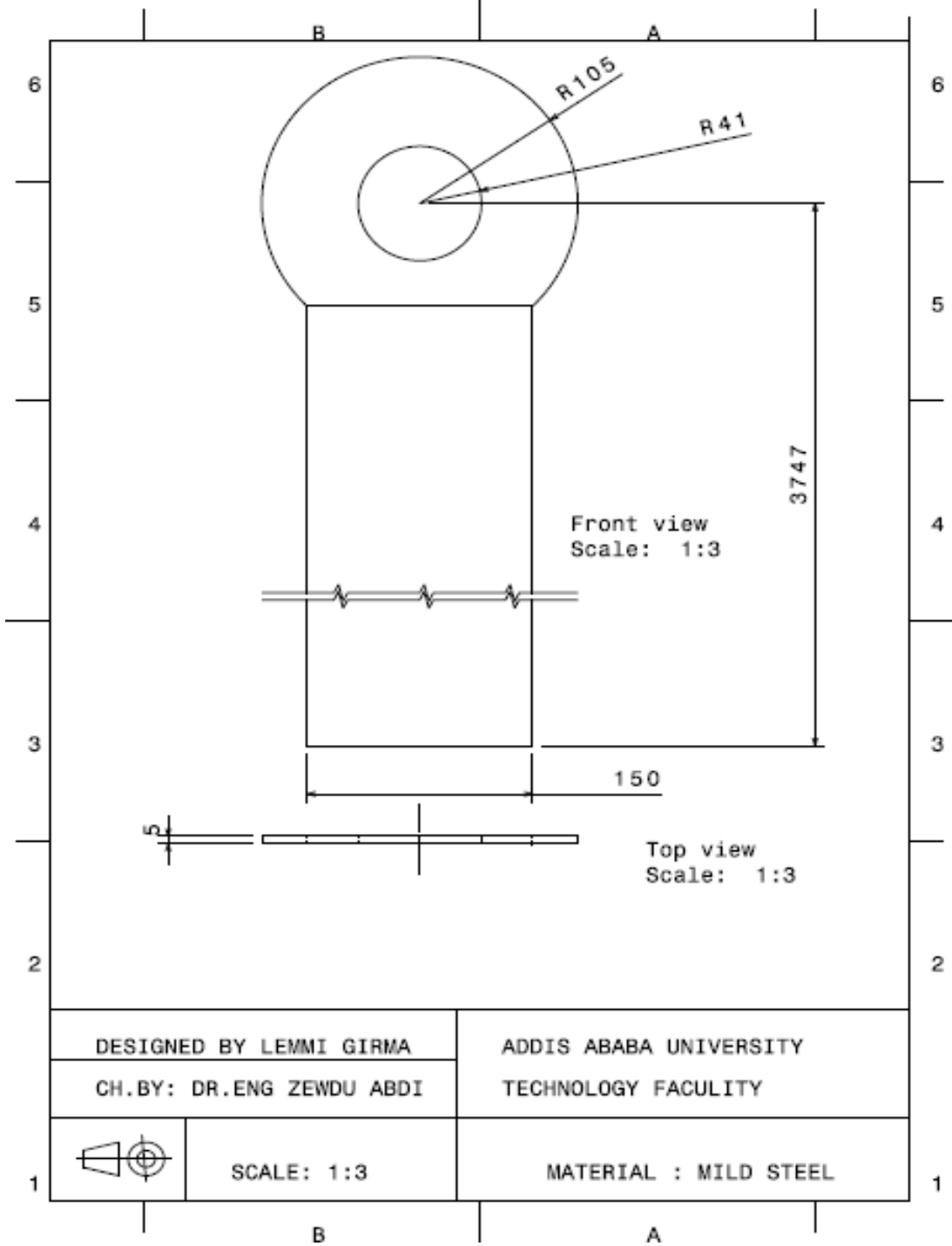

2. chord in belt load side

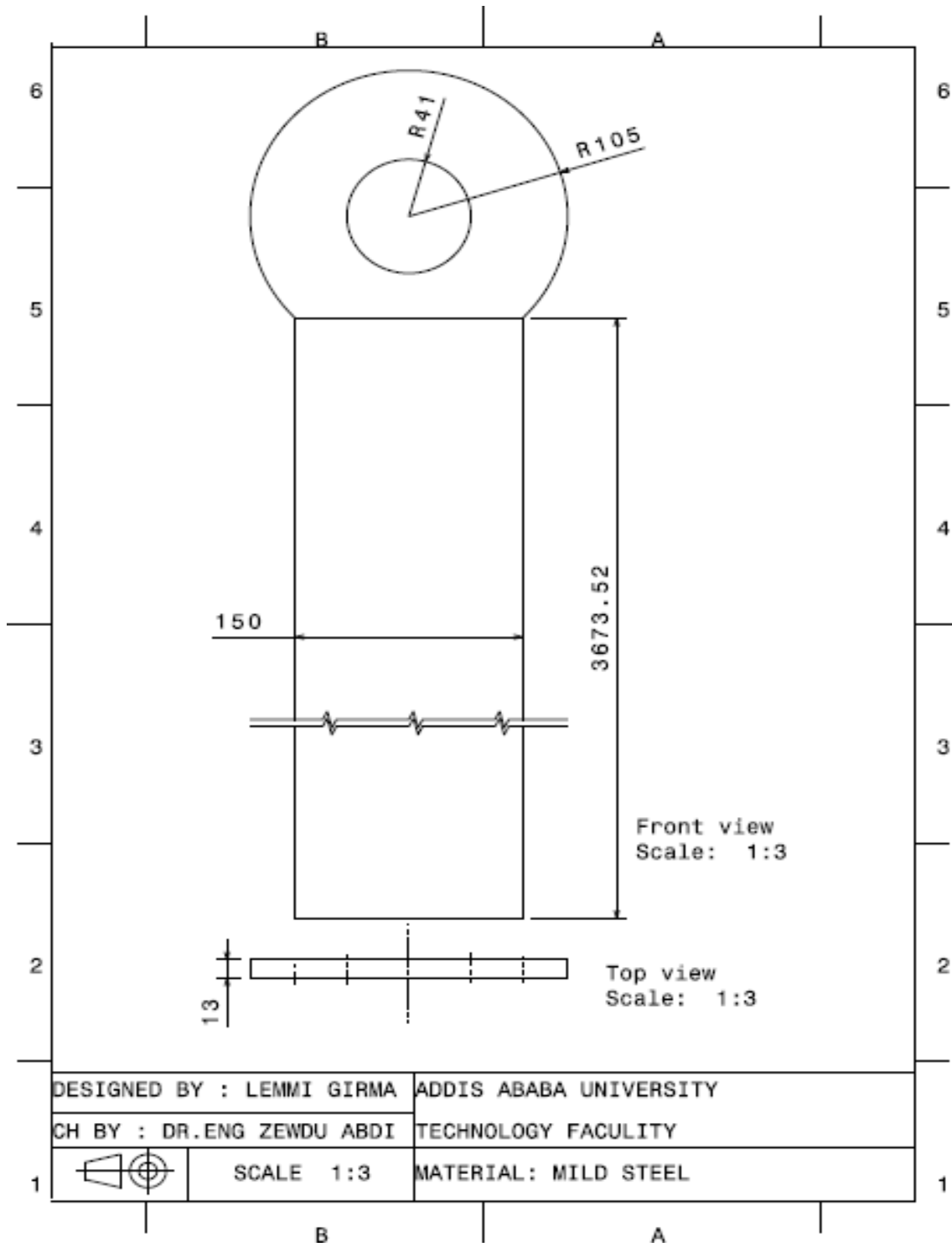

3. Block support in non belt load side

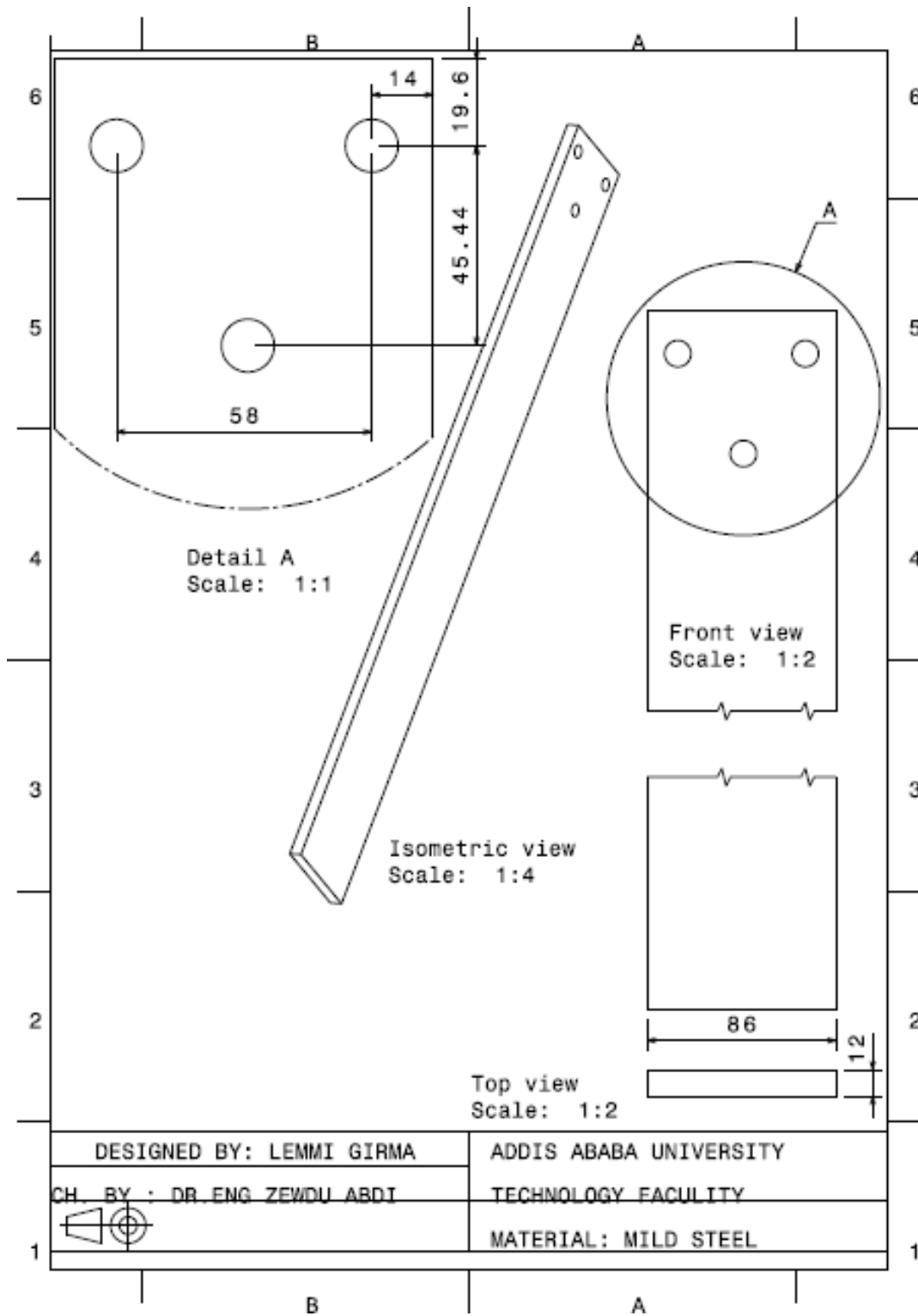

4. Block support in belt load

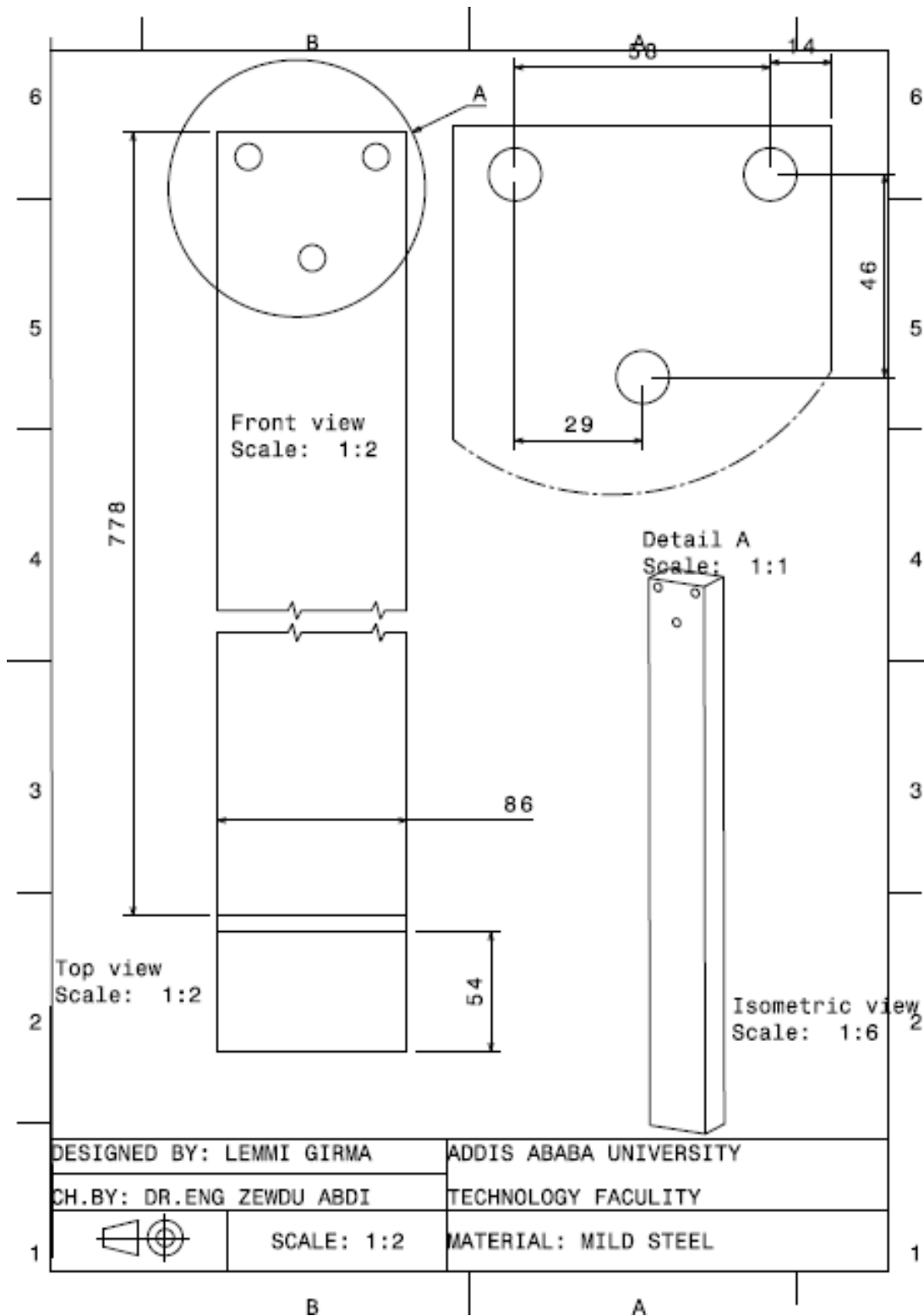

5. Plate at end joint conveyor belt

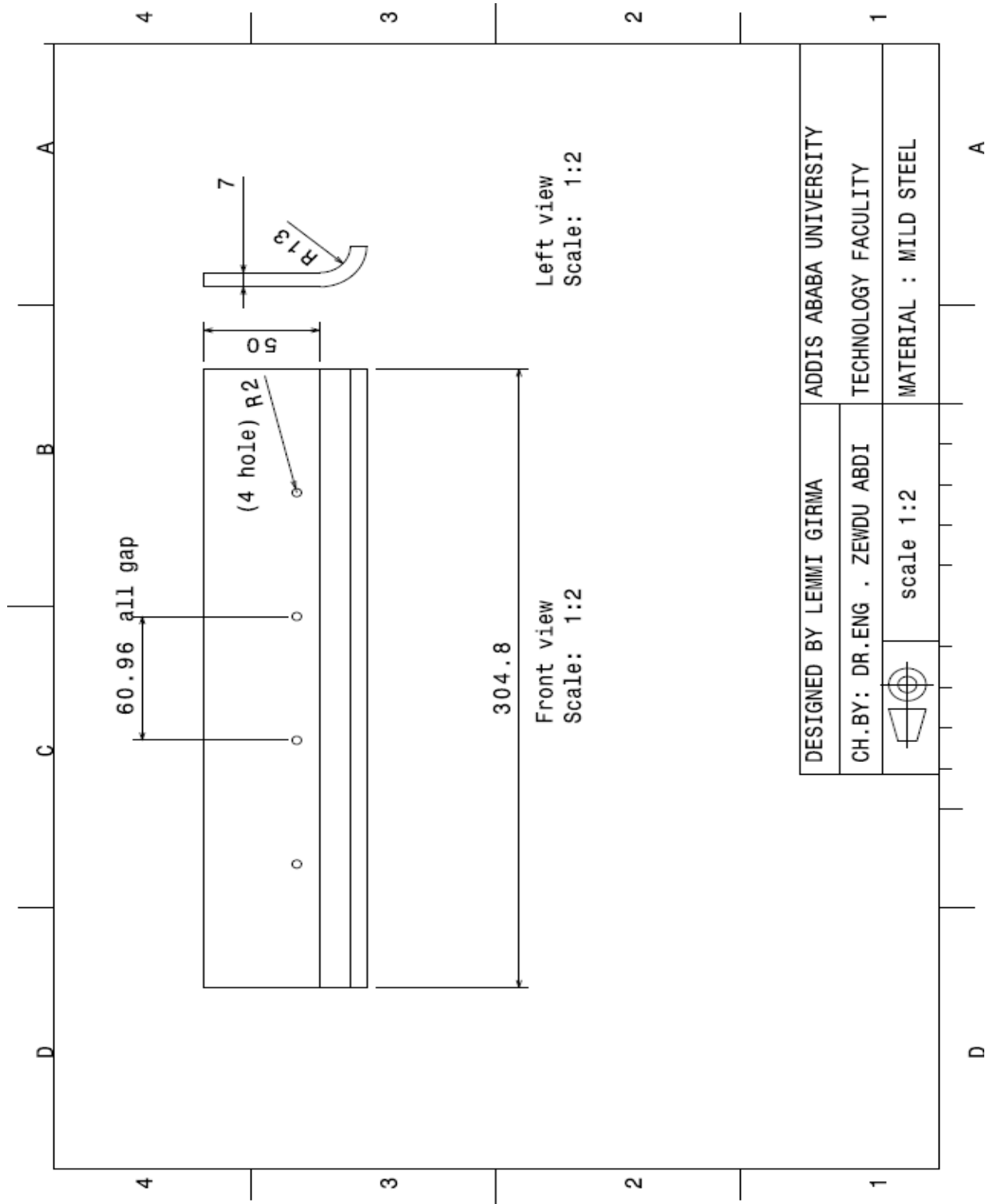

6. Pushing rod for conveyor

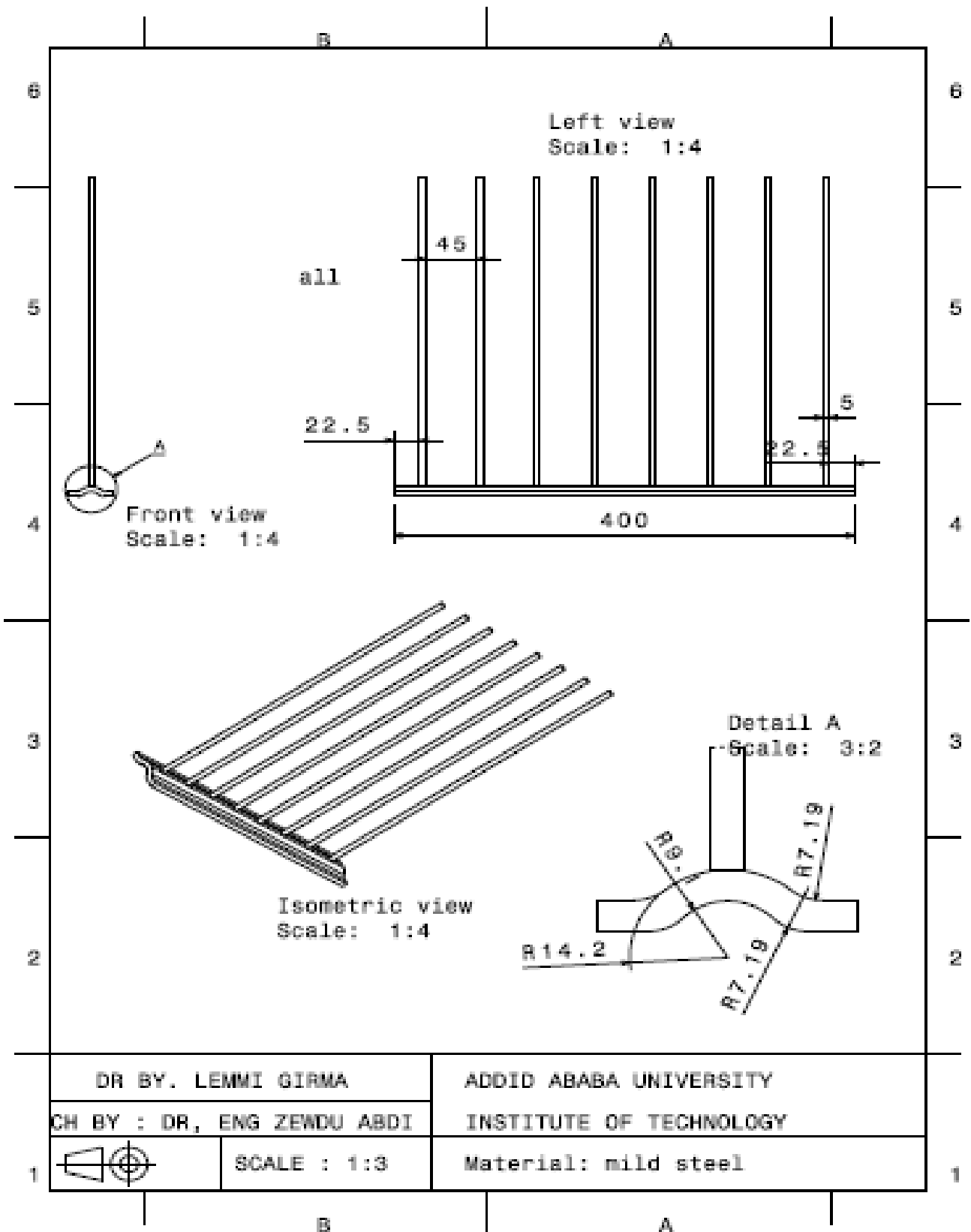

7. Shaft at head and boot

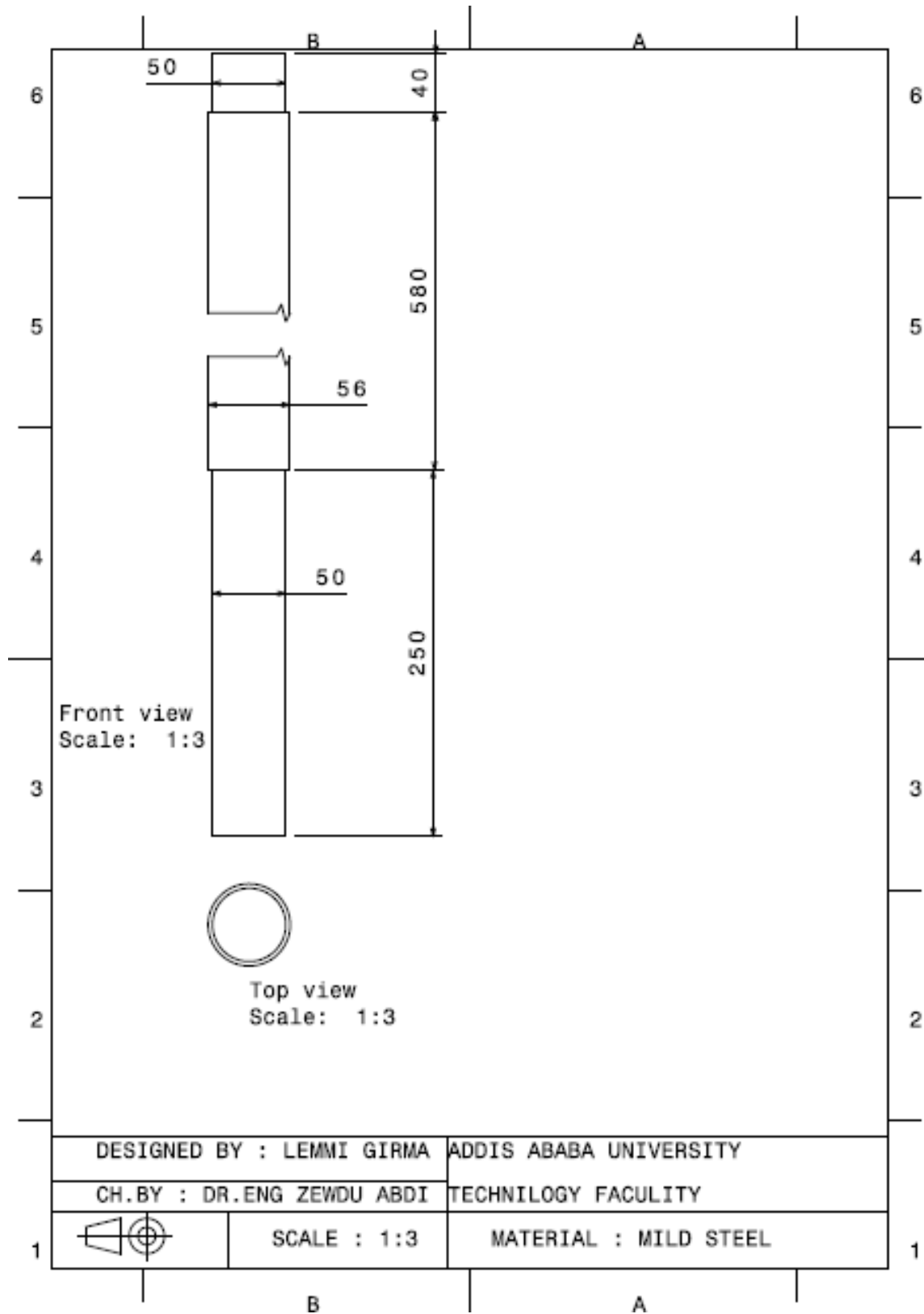

8. Truss EF

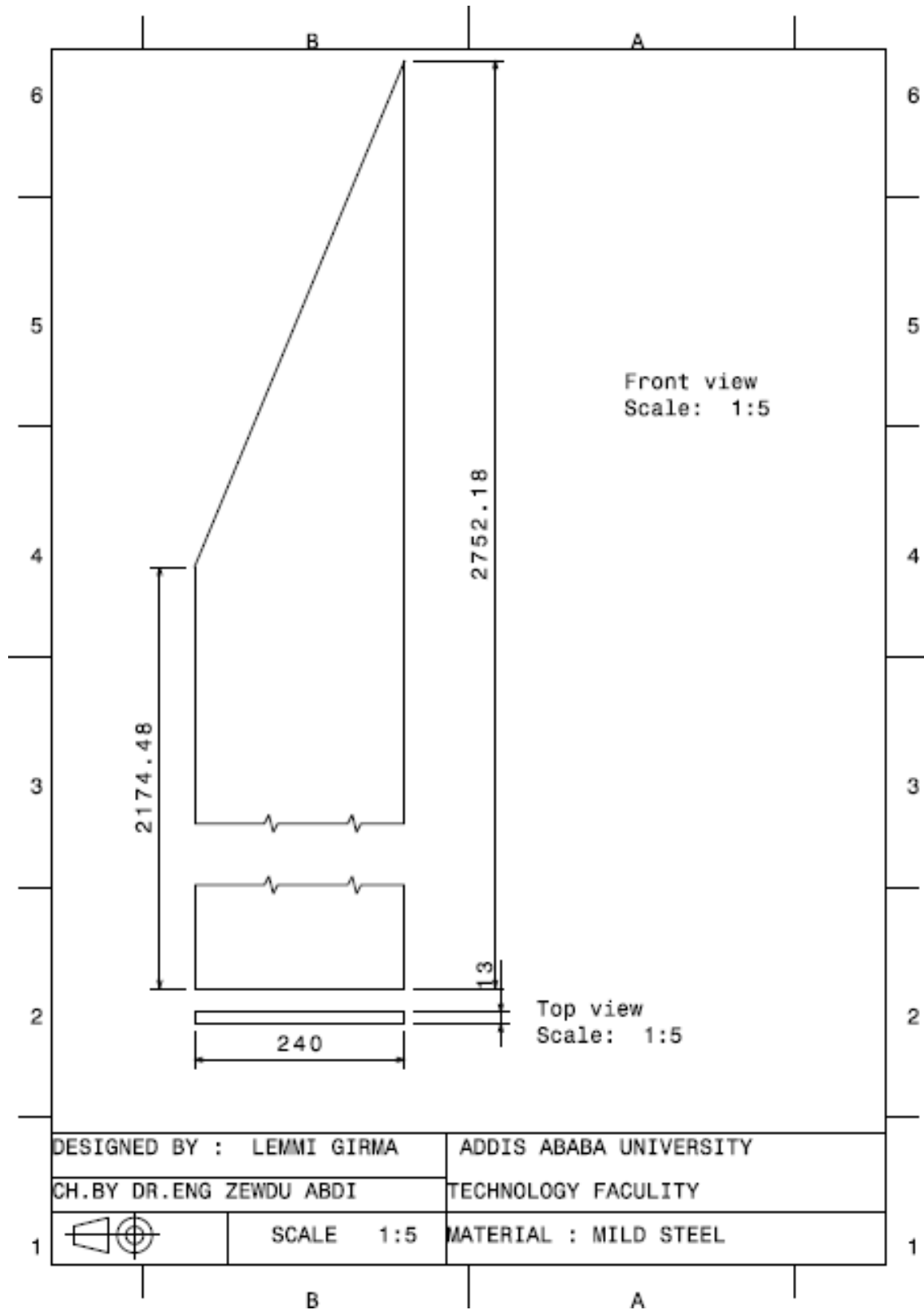

9. Truss E'F'

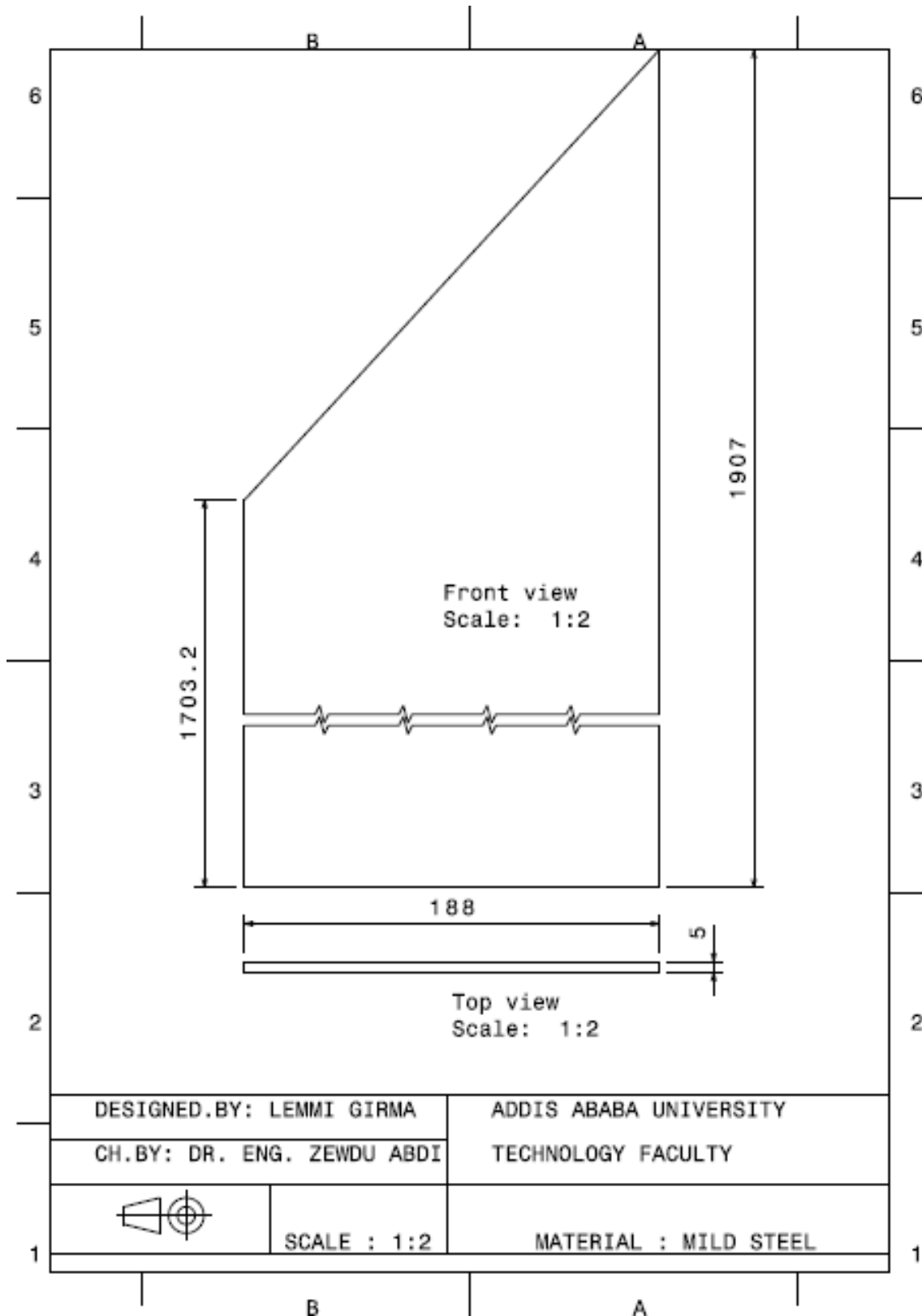

Appendix B-3: Detail of structure support

1. For beam g-e-j

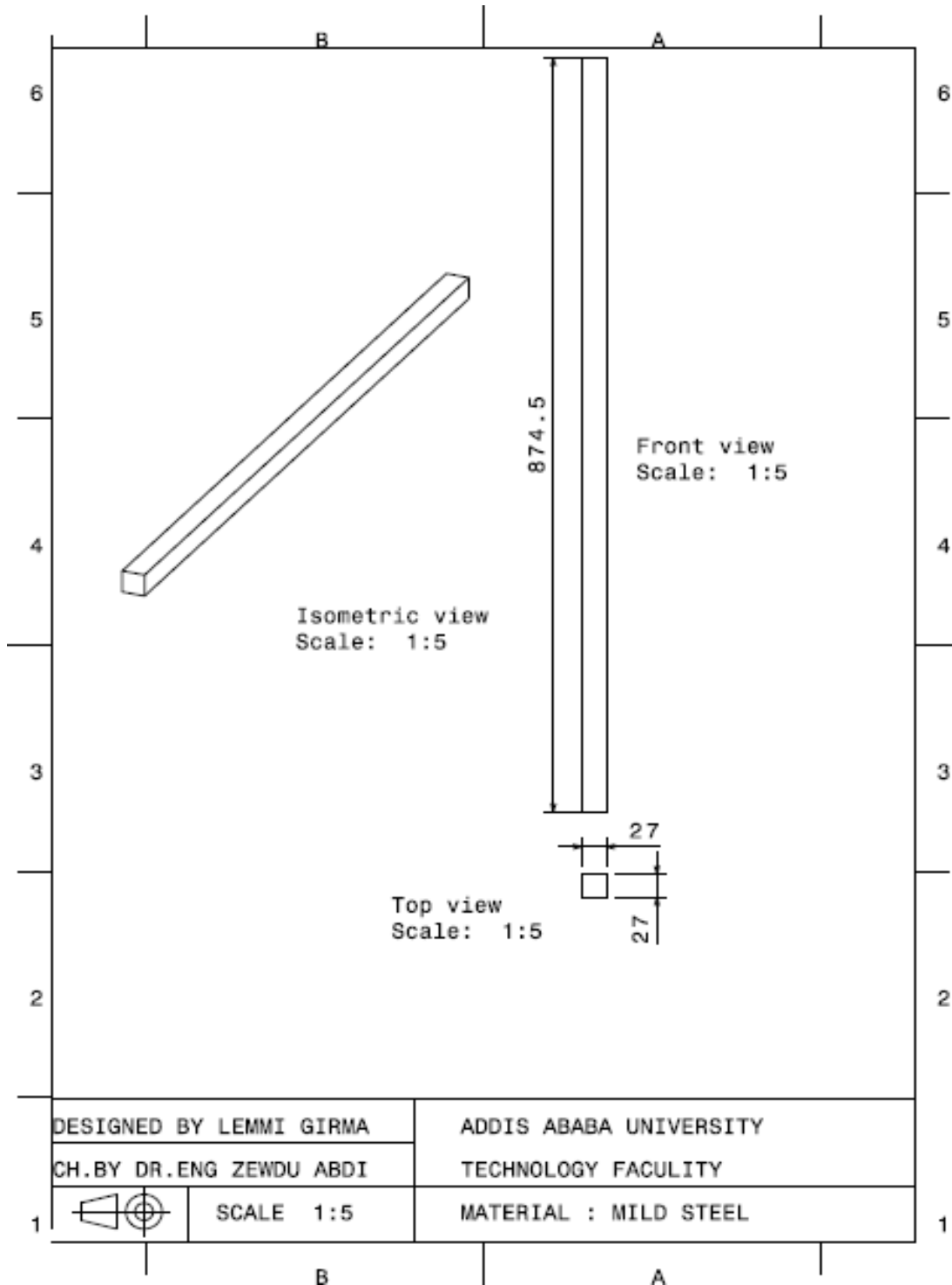

2. Beam h-k-i

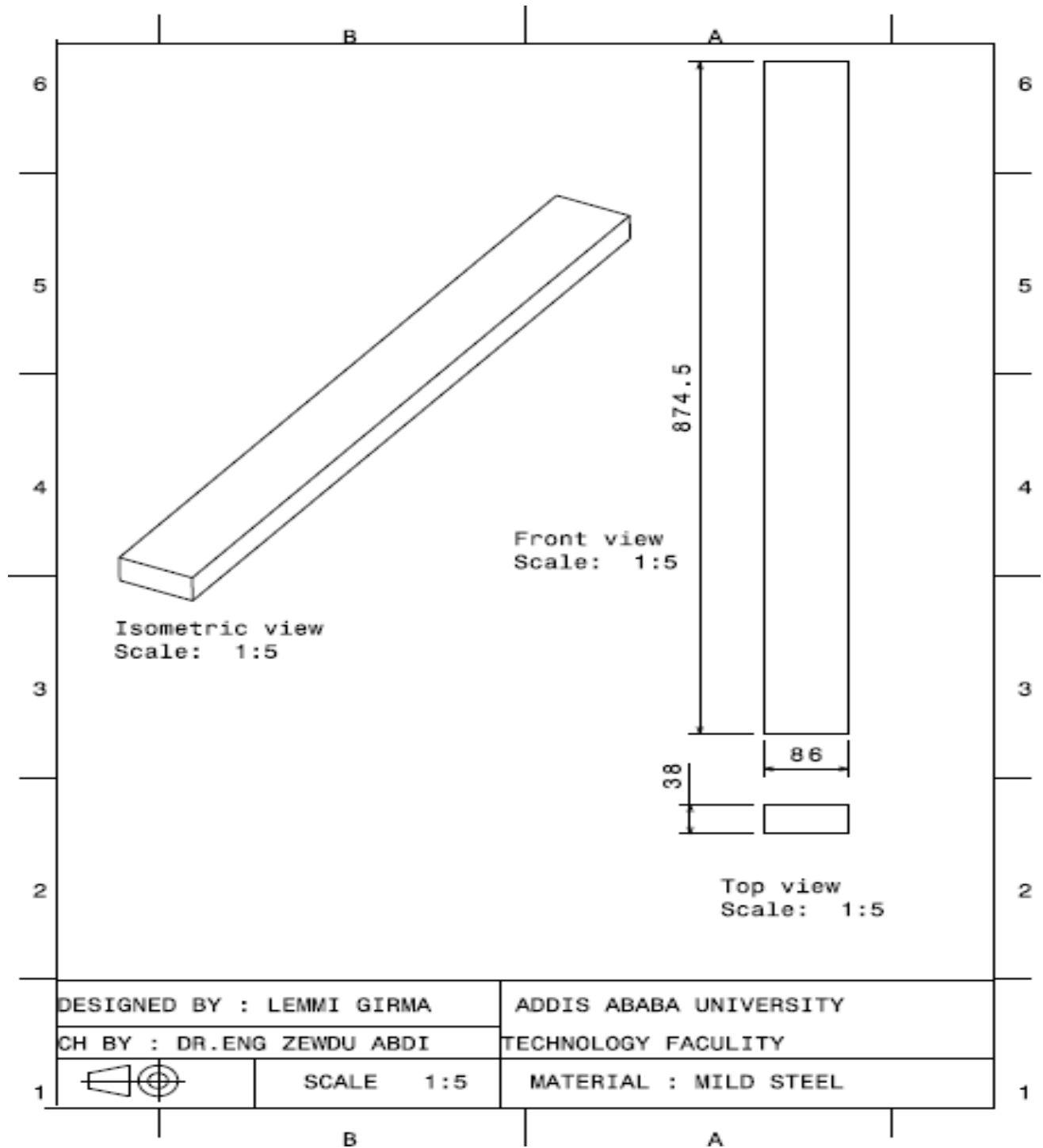

3. beam at front tire

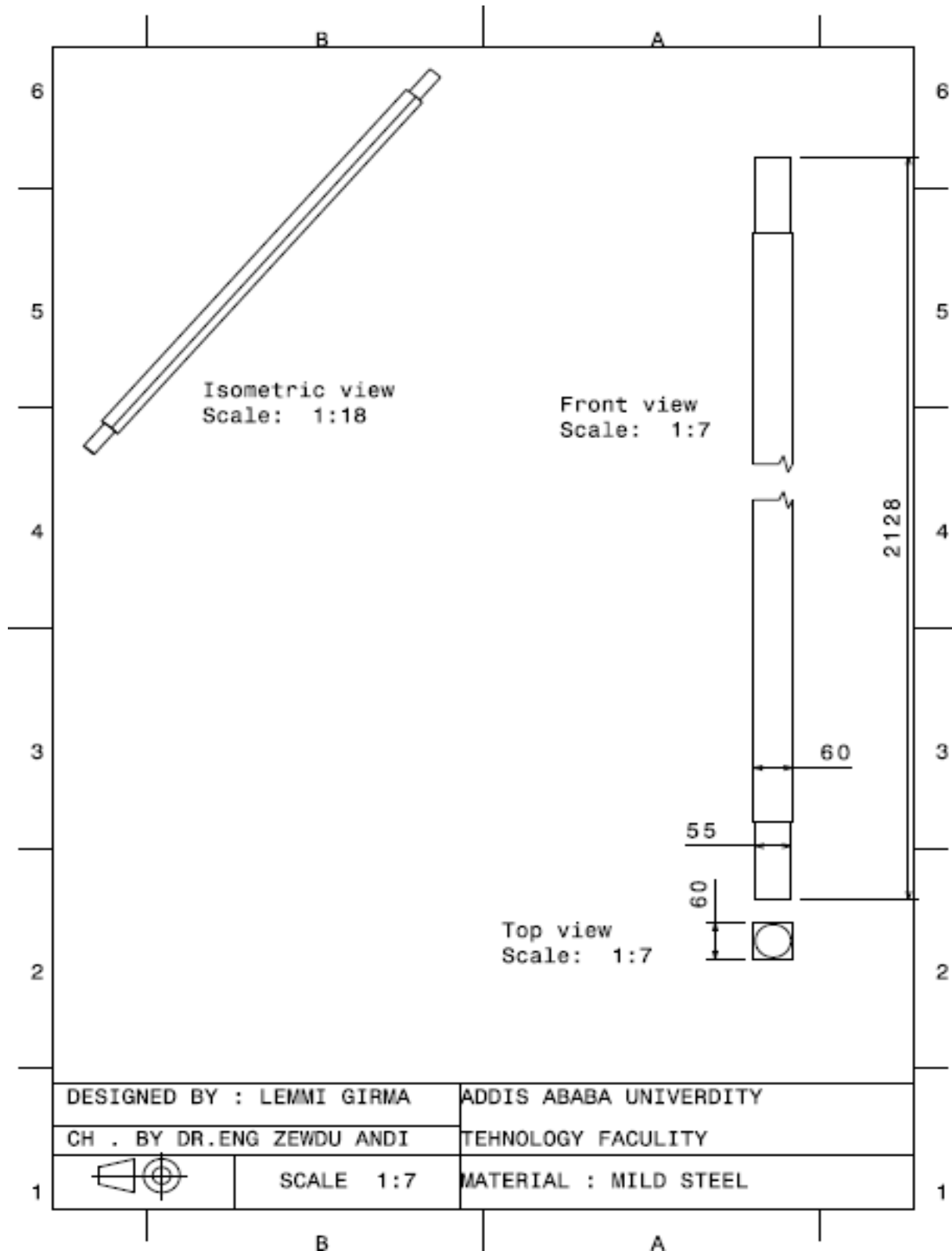

4. Beam at rare tire

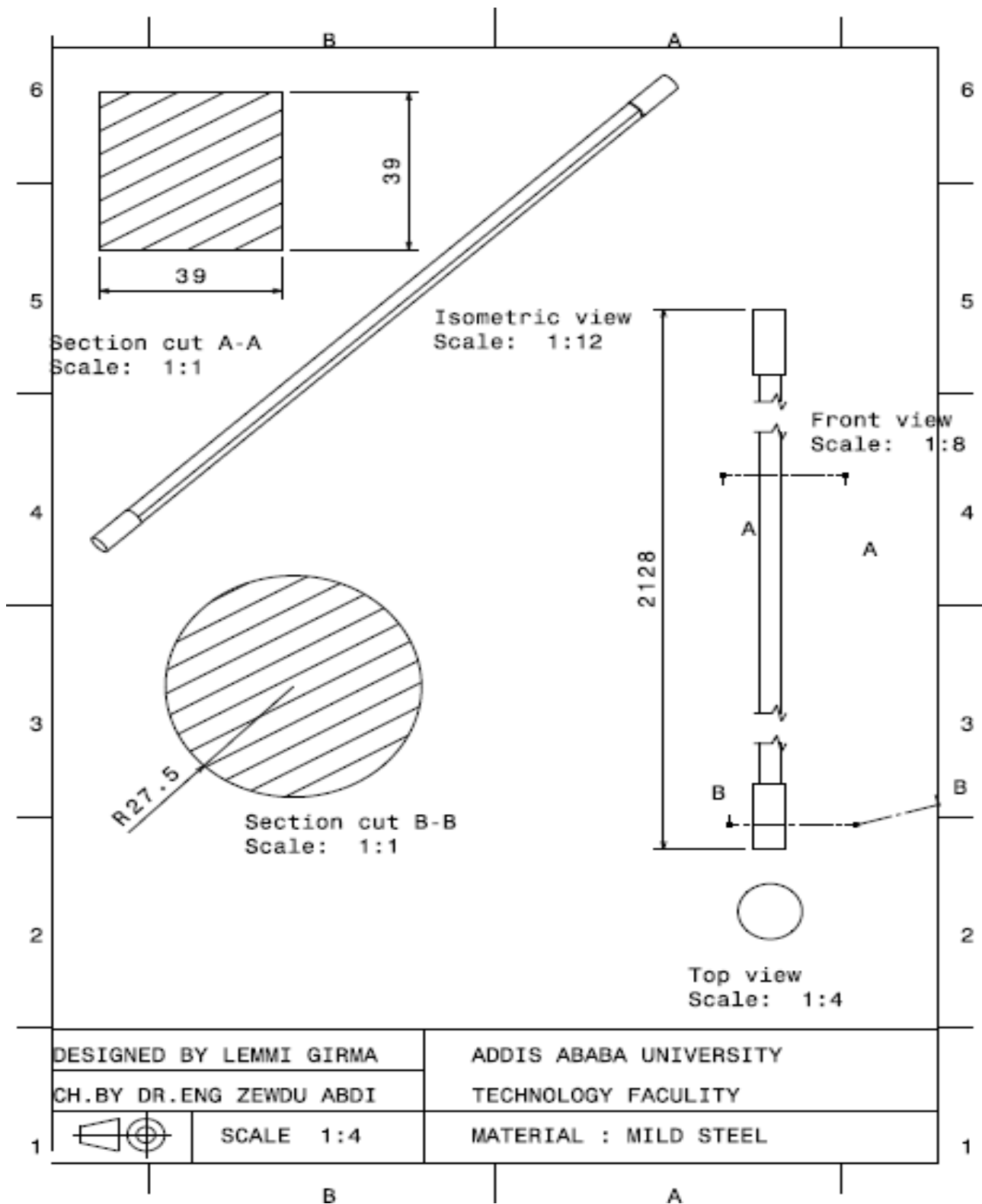

Appendix C: specification of standard for recommended machine part

Appendix C-1: conveyor pulley diameter and belt width relation

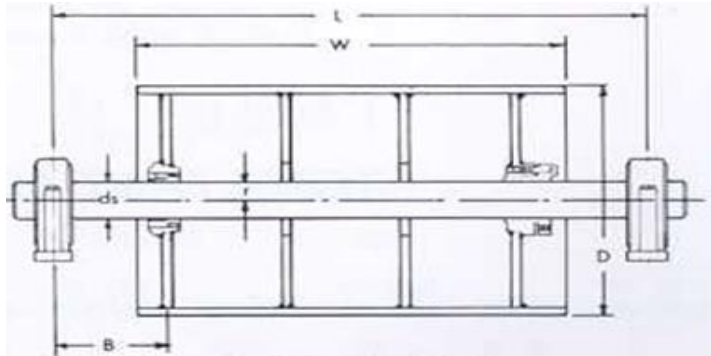

where D - diameter of pulley
W - pulley face width
L - distance between bearing centers
B - moment arm center to bearing center
ds - diameter of shaft

table below shows the relationship between face width of pulley and belt width.

Belt width(mm)	Pulley width(inches)	Belt width(mm)	Pulley width(mm)
152.4	203.2	609.6	660.4
203.2	254	762	812.8
254	304.8	914.4	965.2
304.8	355.6	1066.8	1117.6
355.6	406.4	1219.2	1295.4
406.4	457.2	1371.6	1447.8
457.2	508	1524	1600.2(1676.4)

Appendix C -2: Stresses for welded joints.

Type of weld	Bare electrode		Coated electrode	
	Steady load MPa	Fatigue load MPa	Steady load MPa	Fatigue load Mpa
Fillet weld	80	21	98	35
All types				
Butt weld				
Tension	90	35	110	55

Compression	100	35	125	55
Shear	55	35	70	35

Appendix C-3: standard boundary dimensions for bearings

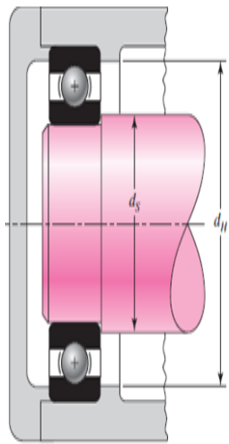

d_s - shaft diameter

d_H - housing shoulder diameter

Bore, mm	OD, mm	Width, mm	Fillet Radius, mm	Shoulder Diameter, mm	
				d_s	d_H
10	30	9	0.6	12.5	27
12	32	10	0.6	14.5	28
15	35	11	0.6	17.5	31
17	40	12	0.6	19.5	34
20	47	14	1.0	25	41
25	52	15	1.0	30	47
30	62	16	1.0	35	55
35	72	17	1.0	41	65
40	80	18	1.0	46	72
45	85	19	1.0	52	77
50	90	20	1.0	56	82
55	100	21	1.5	63	90
60	110	22	1.5	70	99
65	120	23	1.5	74	109
70	125	24	1.5	79	114
75	130	25	1.5	86	119
80	140	26	2.0	93	127
85	150	28	2.0	99	136
90	160	30	2.0	104	146
95	170	32	2.0	110	156

Appendix C-4: flange housing

FNL flanged housings for bearings with an adapter sleeve
 d_s 20 – 60 mm

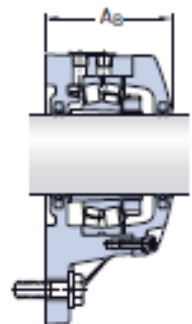
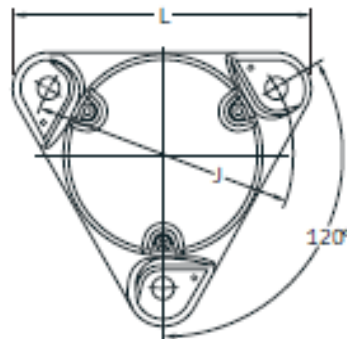
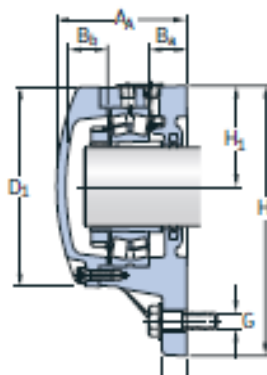

Shaft diam.	Housing dimensions											Mass
	A _A	A _B	A ₁	B ₁	B ₁ ²⁾	D ₁	H	H ₁	J	L	G	
mm	mm											kg
20	–	–	10	15	–	–	100	38	96	110	10	–
25	60,5	60	12	16	15	86	117	44	116	130	10	1,6
30	–	–	12	16	–	–	130	48,5	130	145	12	–
35	67	66	12	17	18	105	143	54	140	160	12	2,4
40	72	70,5	12	19	19	113	160	60	160	179	12	3,2
45	77	75	15	22	21	118	160	60	160	179	12	3,5
50	84	82	15	24	23	127	172,5	65	170	192	12	4,3
55	85	83	15	23	22	142	189	72	180	210	12	5,2
60	88	86	15	22	24	152	203	78	190	225	12	6,3

For missing dimensions please consult SKF

¹⁾ Maximum space, from bearing, for shaft end to end cover

²⁾ Please check availability of the bearing before incorporating it in a bearing arrangement design

