



**ADDIS ABABA UNIVERSITY**  
**INSTITUTE OF TECHNOLOGY**  
**DEPARTMENT OF CIVIL ENGINEERING**  
**POST GRADUATE PROGRAM IN RAILWAY ENGINEERING**

**ASSESSMENT OF NOISE INDUCED FROM ADDIS ABABA LIGHT RAIL TRANSIT  
USING MATHEMATIC QUANTIFICATION METHOD**

A paper submitted to the school of graduate studies of Addis Ababa University in partial fulfillment of the requirements for the Degree of Master in Railway Civil Engineering

**By**

**Mulugeta Mohammed**

**Advisor**

**Ato Mequanennit Mulugeta**

**May, 2017**

The undersigned have examined the paper entitled '**Assessment of Noise Induced from Addis Ababa Light Rail Transit Using Mathematical Quantification Method**' presented by **Mulugeta Mohammed**, a candidate for the degree of **Master of Engineering** and hereby certify that it is worthy of acceptance.

_____ Advisor	_____ Signature	_____ Date
_____ Examiner	_____ Signature	_____ Date
_____ Chair person	_____ Signature	_____ Date

## DECLARATION

I certify that this paper work entitled “Assessment of Noise Induced from Addis Ababa Light Rail Transit using Mathematical Quantification Method” is my own work except for citations which have been duly acknowledged. The work has not been presented elsewhere for assessment and award of any degree or diploma.

Mulugeta Mohammed  
**Author**

\_\_\_\_\_  
**Signature**

\_\_\_\_\_  
**Date**

## ACKNOWLEDGEMENT

I would like to thank the almighty **GOD** for giving me the strength to finish this project. Unlimited gratitude goes to my advisor, **Mr. Mequanennit Mulugeta (MSc)**, for his invaluable advice, guidance and his enormous patience through the development of this project. I also like to thank my loving mother, **Zeritu Fentaw**, who had helped and given me encouragement during the challenging times.

Finally, my gratitude goes to everyone who had contributed to the successful completion of this project.

**TABLE OF CONTENTS**

Declaration.....	i
Acknowledgement.....	ii
List of Symbols.....	V
List of Tables.....	Vii
List of Figures.....	Viii
Abstract.....	ix
<b>Chapter One</b>	
<b>Introduction</b>	
1.1. Background of the Study.....	1
1.2. Statement of the Problem.....	2
1.3. Aim and Scope of the Project.....	2
1.4. Relevance of the Project.....	3
1.5. Outlines of the Project.....	3
<b>Chapter Two</b>	
<b>Literature Review</b>	
2.1. Characteristics of Sound Waves.....	5
2.2. Railway Transit Noise Sources.....	7
2.3. Impacts of Railway Induced Noise.....	7
2.4. Factors of Railroad Noise.....	8
2.5. Descriptors of Railroad Noise.....	8
2.6. Railway Noise Impact Assessment .....	10
2.7. Mitigation Measures of Railways Noise.....	13
<b>Chapter Three</b>	
<b>Study Methodology</b>	
3.1. General Methodologies and Procedures used in Assessment.....	15

**Chapter Four****Analysis**

4.1. Data collected on sensitive receptors.....	18
4.2. Train scheduling in AALRT.....	20
4.3. Background noise.....	22
4.4. Project induced noise.....	23
4.4.1. Sample calculations.....	23
4.4.2. Summary of results.....	27

**Chapter Five****Evaluation**

5.1. Evaluation of Project Noise Based on Existing Noise.....	29
5.2. Evaluation of Project Noise Based on Triggers Level.....	30
5.3. Combined Effects of Project and Background Noise.....	31
5.4. Discussion.....	34
5.5. Mitigation Measures.....	36

**Chapter Six**

6.1. Conclusion.....	37
6.2. Recommendation.....	37

**References and Further Reading.....38****Appendices**

Appendix A: Glossary of Terms.....	40
Appendix B: Determinations of Base Line Noise Level.....	43
Appendix C: Mathematical Quantification of Railway Noise.....	45
Appendix D: Railways Noise Criteria.....	58

## LIST OF SYMBOLS

**$\alpha$** : Angle of orientation of segment. More precisely it is the acute angle between the line drawn through the reception point position, parallel to the track, and the line bisecting the angle of view of the segment (degrees).

**$\delta$** : Path length difference between the direct ray and the diffracted ray due to screening of the source line (meters).

**$\theta$** : Angle of view of the segment (degrees).

**$\theta'$** : Combined angle of view of reflecting surface on the far side of the traffic stream facing the reception point (degrees).

**A**: Barrier screening potential determined from the path difference,  $\delta$ .

**a**: Mean opening between buildings measured along a row of buildings (meters).

**b**: Mean length of buildings evaluated along a row of buildings (meters).

**d**: Shortest horizontal distance between the reception and the source line (meters).

**d'**: Shortest slant distance from the reception point to the source line (meters).

**D**: Shortest horizontal distance between the source line and the near side face of a noise barrier (meters).

**Q<sub>day</sub>**: Total number of trains of a particular type passing the reception points during the period 0600-2400hrs.

**Q<sub>Night</sub>**: Total number of trains of a particular type passing the reception points during the period 0000-0600hrs.

**AALRT**: Addis Ababa light rail transit.

**dB**: Abbreviation for decibel.

**dB(A)**: The noise level in decibels, obtaining using the 'A' weighted network.

**ERC**: Ethiopian Railway Corporation

**FHA**: Federal Highway Administration

**FTA**: Federal Transit Administration

**h**: Height of the reception point relative to the source line (meters)

**hs**: Height of the source position above the ground (meters)

**H:** Average height of propagation between the reception point and the effective source position above the intervening ground (meters).

**HZ:** The unit of sound frequency in cycles per second.

**I:** Proportion of sound absorbing ground between the segment source line and the reception point.

**L<sub>Aeq</sub>:** The average noise energy during the measurement period which is equivalent to the fluctuating sound level actually occurring.

**L<sub>Aeq,(1h)</sub>:** Equivalent noise levels, addressing the worst case average noise exposure of non-residential sensitive receivers during their hours of operation.

**L<sub>Aeq,(9h)</sub>:** Equivalent noise level between 10pm and 7am

**L<sub>Aeq,(15h)</sub>:** Equivalent noise level between 7am and 10pm

**L<sub>Amax</sub>:** Maximum noise levels due to individual pass-by events.

**L<sub>DN</sub>:** Day-night average sound level

**SEL:** Sound exposure level

**SPL:** Sound pressure level

**WHO:** World health organization

**LIST OF TABLES**

Table-4.1: description of sensitive receptors within the evaluation distance.....18

Table-4.2: train drive scheduling in Addis Ababa light rail transit.....21

Table-4.3: estimated background noise level.....22

Table-4.4: project induced noise levels.....28

Table-5.1: evaluation of project noise based on existing noise.....29

Table-5.2. evaluation of project noise based on trigger level.....30

Table-5.3. combined effect of project and background noise .....32

Table B: estimated of baseline ambient noise level.....44

Table C-1: sound exposure level corrections for individual railway vehicle.....46

Table C-2: correction to rolling noise for different  
           Track and track support structure.....47

Table D-1: noise criteria for residential receiver .....58

Table D-2: External noise criteria for non-residential  
           Receivers during hours of operation.....59

Table D-3: internal rail noise trigger levels applicable to light rail  
           Development for sensitive land use other than residential.....59

Table D-4: land use categories and metrics for transit noise impact criteria.....60

**LIST OF FIGURES**

Figure 1.1: study approach and process.....4

Figure 2.1: A – weighted curve.....6

Figure 4.1: residential building found between AYAT and ABO MAZORIYA station.....24

Figure 4.2: KETY saint Gebriel higher clinic between MESHUALEKIYA and STADIUM station.....26

Figure 5.1: graph for approximate decibel addition .....32

Figure C-1: source and receiver geometry for the calculation of the distance correction.....48

Figure C-2: site geometry to evaluate the path difference ( $\delta$ ) for obstructed correction.....50

Figure C-3: evaluating the path difference ( $\delta$ ) for parallel and non-parallel barriers.....51

Figure C-4: screening by buildings.....52

Figure C-5: screening by embankments and cuttings.....54

Figure C-6: screening by retained cutting and dual barriers .....55

Figure C-7: calculating the reflection correction for facades facing the reception  
                   Point on the far – side of the railway traffic stream.....56

Figure D-1: noise impact criteria for transit project.....60

## ABSTRACT

Railway transport system gives several advantages to the overall development of a country like increased level of passenger or cargo utilization over a limited space, safe and reliable transport with lowest accident rate and others. Although it has such advantages, increased train movements, extended rail operating hours and maintenance activities of railway system might adversely affect residents living or working near the railway route.

Noise induced from the rail transport system is the most usual and major impact on peoples living or working near the railroad. The norm of noise level is affected by vehicle type, traffic speed, distance, gradient and barriers. When the level of noise gets higher, residents living in nearby noise susceptible buildings; like hospitals, clinics, schools, assembly halls might be exposed to annoyance, hearing lose, sleeplessness and damages to their material. The degree of the impact is measured by comparing the existing noise level to the standard limit.

In Addis Ababa different noise susceptible buildings exist near the railway route. The assessment result shows background noise level due to roadways and local activities is higher than the noise level from rail line. The railway operation is added to the existing system does not have a significance change in the noise level induced to nearby buildings. But, the noise impact should be assessed if some improvements are made on the existing system. For instance, if a single train is added to the current train couple system, rail noise will start to have adverse impacts. Also, if headway time is increased to 6 minute, negative impacts might be resulted. When this happens suitable mitigation measures like reallocation and changing building purpose can be suggested.

---

### Key Word

Noise

Head time

Adverse impacts

Train couple

susceptible buildings

## CHAPTER ONE

### INTRODUCTION

#### 1.1. Background of the Study

Railroad transport system gives several advantages to the overall development of a country. These includes high level of passenger or cargo utilization over a limited space, safe and reliable transport with lowest accident rate, offers comfortable ride options, and high degree of automation and management. Railroad transport is an important component for achieving sustainable cities and preserving the environment.

Nevertheless, adverse impacts on residents living or working alongside the rail lines might occur from exposure to increased train movements, extended rail operating hours and development along transport routes that are not designed to mitigate noise.

Among different negative impacts, noise induced from the rail transport operation is the major one. If sufficiently loud, noise may adversely affect people in several ways. For example, noise may interfere with human activities, such as sleep, speech communication, and tasks requiring concentration or coordination. It may also cause annoyance, hearing damage, and other physiological problems. Several noise scales and rating methods are used to quantify the effects of noise on people. Those scales and methods consider factors like loudness, duration, time of occurrence, and changes in noise level with time. However, all the stated effects of noise on people are subjective.

Environmental impact assessment should be conducted to know the level of induced noise so that the environment can be kept safe and the residents can be saved from resulted dangers. The assessment results have to be compared to standard levels. If the level of noise is beyond the standard limit, counter measures should be suggested and designed. The counter measure for that specific site condition should be appropriately fit the existing condition.

There are two basic approaches of environmental impact assessment. The first approach is an assessment conducted by direct measurement on site. This is important for assessing the impact of existing railway network on nearby structures. In addition, if new building is planned to be constructed near the railroad, the level of noise at the location can be determined using direct measurement approach. The second approach is an assessment using prediction methods. This assessment method is applied to have a close approximation of induced noise level of a newly planned railway network.

Moreover, if there is lack of site measuring equipment's, the noise level can be predicted. This can be done using either software applications or mathematical prediction methods.

### **1.2. Statement of the Problem**

Susceptible structures like hospitals, clinics, schools, residential buildings, reservoirs, assembly halls etc. exist alongside **Addis Ababa Light Railway Network**. Since Addis Ababa is the capital city of Ethiopia, future urbanization might include construction of susceptible structures near the railroad. Moreover, for better transport facility provision, future development of other railway networks might be proposed.

As a result, assessment work is vital for Addis Ababa Railway network. Through this assessment the level of noise can be known so that engineering judgements like appropriate counter measures can be suggested.

### **1.3. Aim and Scope of the Project**

The aim of this project is to quantify noise levels induced from the existing AALRT and then to study those levels by applying appropriate assessments and standards. For most cases of developing countries noise levels of new or existing railroad might not get sufficient focuses due to the lower growth of the town. But future development cases may bring environmental impact of railway under question. Then it may be hard or not comfortable to avoid or reduce those impacts.

***The central issue in this project is to review noise assessment and quantification methods and then assess Addis Ababa light rail transit.***

The following four project steps will guide the review towards a better understanding of railroad induced noise assessment.

1. List the impacts of induced noise
2. Describe the influence of noise assessment: explaining the importance of dealing noise for a particular railway.
3. Review Assessment and quantification methods: procedures and formulas will be refined for most approximate results.
4. Assessment of Addis Ababa Light Rail Transit: Using refined methods of assessment and noise quantification techniques, Assessment is done.

After going through these steps and getting more acceptable assessment procedures and quantification methods, Addis Ababa Light Rail Transit will be studied or assessed and then Engineering Judgements will be followed.

#### **1.4. Relevance of the Project**

Different types of structures might exist near the existing railway transport system. In addition to this new railway line might be planned to be constructed in the urban area. Various structures might also be designed to be constructed with the location near the railroad. Those structures, like schools, hospitals, residential and others, found or planned near the railway transport system are susceptible to noise impacts.

All susceptible structures have their own tolerance limit which is found in noise level standard limit criteria. If the levels of noise exceed the tolerance limit of that specific structure as explained in the standard, suitable mitigation measure should be taken. Those counter measures can be from the railway or structure point of view. Through this the safety of working condition can be kept in equilibrium.

In order to perform this, environmental assessment should be conducted. If the railway is new, its impact on to nearby structures should be assessed. Moreover, if new structure is planned to be constructed near the existing railroad, the impact of such existing railway should be assessed. This assessment is effectively done using direct measurement devices. But in case those devices do not exist, some alternatives should be available. Also before the construction of new railway system, direct measurements could not be performed.

Being part of avoiding this problem, the project focus on refining assessment and quantification methods and then assessing Addis Ababa Light Rail Transit.

#### **1.5. Outlines of the Project**

The project report is comprised of six chapters.

*Chapter One* introduces the overall study and consists of back ground of the study, statement of the problem, aim and scope of the project and relevance of the study. Background of the study discusses briefly about the basics of the study. Statement of the problem defines the problem that the study intends to examine. The aim of the study is directly driven from the study problem. Scope of the study informs about the boundary conditions of the project, and relevance of the study explains the importance and the need of the study.

*Chapter Two* contains the relevant literatures about this study and helps us to understand the undergoing project research. *In Chapter Three*, the methodology used to make this study, design of the project research; types of required data, source of data,

assessment techniques and procedures, specific location of study area, and methods of data analysis are explained.

This is followed in **chapter 4** by the Assessment made for Addis Ababa Light Rail Transit based on the refined methods in chapter 3 and in **chapter 5** evaluation is made using this analysis or assessment output and based on standards reviewed in chapter 2. Field surveying is the first procedure followed to get the characteristics of nearby buildings.

**Chapter 6** is the concluding chapter. First the results from the earlier chapters are discussed. Finally, some recommendations for further research are given.

The schematic illustration of the study process is as shown in figure 1.1 below.

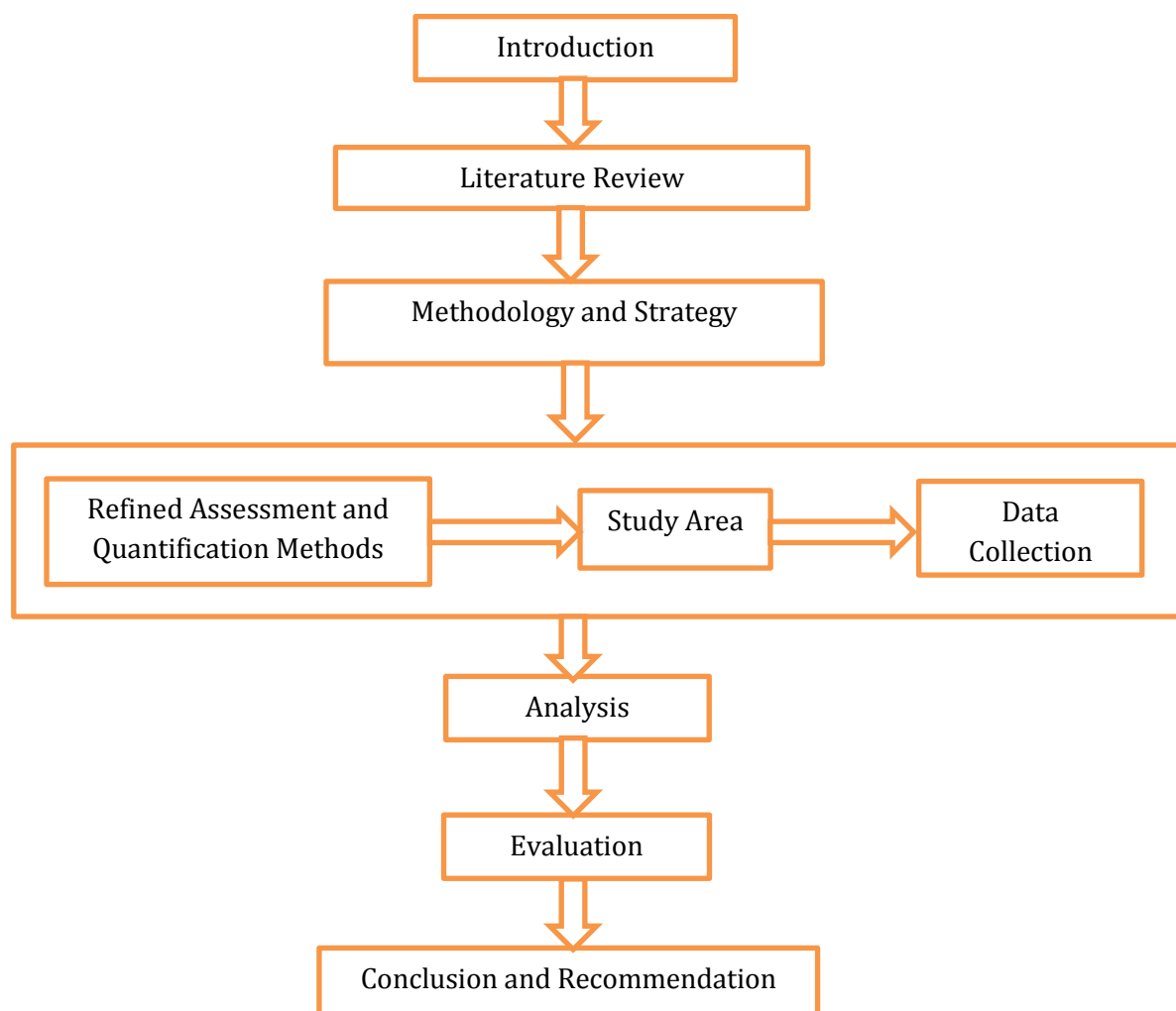

Fig. 1.1 Study Approach and Process

## CHAPTER TWO

### LITERATURE REVIEW

A literature review of previous research papers, manuals and books on the characteristics of railway noise, transit noise sources, impacts of railways induced noise, factors affecting noise level, descriptors of transit noise, measurement techniques of railroad induced noise, railway noise impact assessment and mitigation measures of railways noise is done. This allows the identification of areas that should be assessed in this research project paper.

#### 2.1. Characteristics of Sound Waves

Sound waves are characterized by their generic properties such as amplitude, frequency, time pattern and wavelength. [3]

##### Amplitude of Sound Wave

Loudness of a sound depends on the amplitude of the fluctuations above and below atmospheric pressure associated with a particular sound wave. The quietest sound that can be heard by most humans, the "threshold of hearing," is a sound pressure of about 20 micro Pascals, and the loudest sounds typically found in our environment range up to 20 million micro Pascals. Because of the difficulty in dealing with such an extreme range of numbers, acousticians use a compressed scale based on logarithms of the ratios of the sound energy contained in the wave related to the square of sound pressures instead of the sound pressures themselves, resulting in the "sound pressure level" in decibels (dB). Sound pressure level (SPL) is defined as:

$$\text{SPL} = 10 \log_{10} (p_{\text{rms}}^2 / p_{\text{ref}}^2) = 20 \log_{10} (p_{\text{rms}}/p_{\text{ref}}) \text{ dB, where } p_{\text{ref}} = 20 \text{ micro Pascals.}$$

##### Frequency of Sound Wave

Frequency is the number of times the fluctuation of air pressure or sound occurs in one second. Noise is made up of many frequencies, all blended together in a spectrum. Human hearing covers the frequency range of 20 Hz to 20,000 Hz.

Our human hearing system does not respond equally to all frequencies of sound. For sounds normally heard in the environment, low frequencies below 250 Hz and very high frequencies above 10,000 Hz are less audible than the frequencies in between. Acoustical scientists measured and developed frequency response functions that characterize the way people respond to different frequencies. These are the so-called

A, B- and C-weighted curves, representing the way people respond to sounds of normal, very loud and extremely loud sounds, respectively. Environmental noise generally falls into the “normal” category so that the A- weighted sound level is considered best to represent the human response. The A-weighted curve is shown in Figure 2-2. This curve shows that sounds at 50 Hz would have to be amplified by 30 dB to be perceived equally as loud as a sound at 1000 Hz at normal sound levels.

### Time Pattern of Sound Wave

Environmental noise generally derives, in part, from a conglomeration of distant noise sources. Such sources may include distant traffic, wind in trees, and distant industrial or farming activities, and all part of our daily lives. These distant sources create a low-level "background noise" in which no particular individual source is identifiable. Background noise is often relatively constant from moment to moment, but varies slowly from hour to hour as natural forces change or as human activity follows its daily cycle. Superimposed on this low-level, slowly varying background noise is a succession of identifiable noisy events of relatively brief duration. These events may include single-vehicle passbys, aircraft flyovers, screeching of brakes, and other short-term events, all causing the noise level to fluctuate significantly from moment to moment.

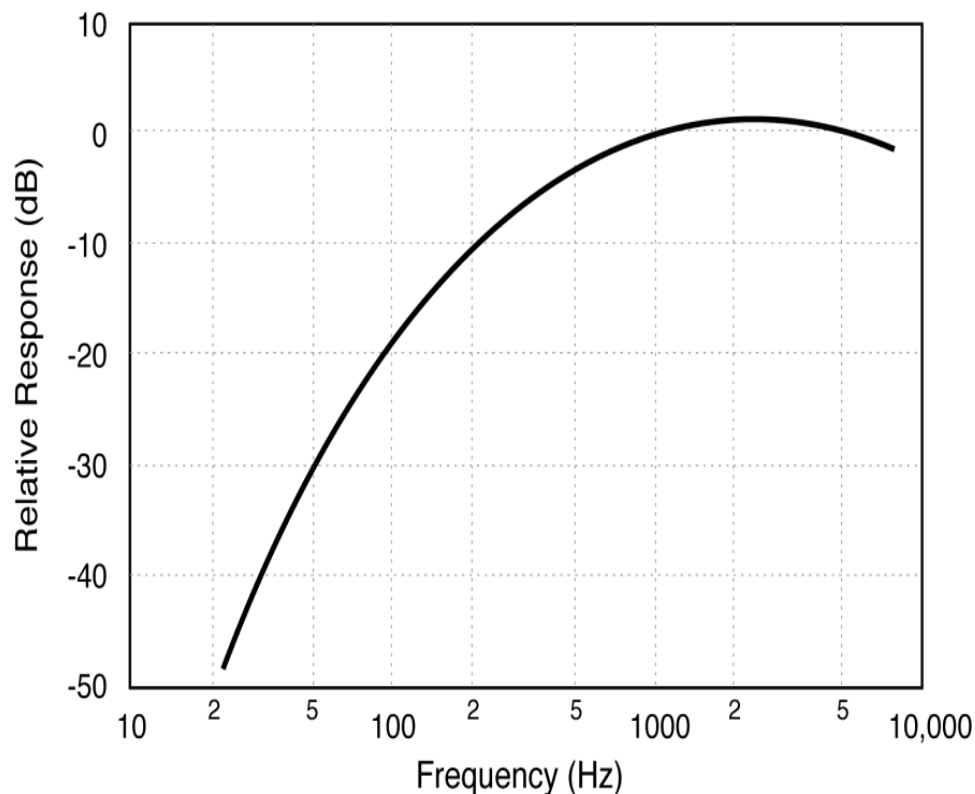

Figure 2.1. A-weighting Curve

## 2.2. Railway Transit Noise Sources

The following are the major sources for railway noise.<sup>[4]</sup>

- Rolling noise
- Power equipment noise
- Aerodynamic noise

At low speed, power equipment noise is the dominant source, whereas at medium speed the dominant source is rolling noise. Only at very high speed does the aerodynamic noise become an important factor. Many sources identify freight trains as the noisiest trains and they mostly operate outside high-speed lines. On the other hand, speed dependence is less for diesel-powered commuter rail trains, particularly at low speeds where the locomotive exhaust noise dominates.

As speed increases, wheel-rail noise becomes the dominant noise source and diesel-and electric-powered trains will generate similar noise levels. For transit vehicles in motion, close-by sound levels also depend up on other parameters, such as vehicle acceleration and vehicle length, plus the type /condition of the running surfaces. For very high-speed rail vehicles, air turbulence can also be a significant source of noise .In addition, the guide way structure can also radiate noise as it vibrates in response to the dynamic loading of the moving vehicle. Transit vehicles are equipped with horns and bells for use in emergency situations and as a general audible warning to track workers and trespassers within the right-of-way as well as to pedestrians and vehicles at high way grade crossings .Horns and bells on the moving transit vehicle, combined with stationary bells at grade crossings can generate noise levels considered to be extremely annoying to nearby residents. Noise is generated by transit vehicles even when they are stationary. For example, auxiliary equipment often continues to run even when vehicles are stationary –equipment such as cooling fans on motors, radiator fans, plus hydraulic, pneumatic and air-conditioning pumps. Noise is also generated by sources at fixed-transit facilities .Such sources include ventilation fans in transit stations ,in subway tunnels ,and in power substations, equipment in chillers plants, and many activities within maintenance facilities and shops.

## 2.3. Impacts of Railway Induced Noise

The degree to which noise can affect the human environment range from levels that interfere with speech and sleep(annoyance and nuisance) to levels that cause adverse health effects (hearing loss and psychological effects).Human response to noise is

subjective and can vary greatly from person to person. Factors that influence individual response include the intensity, frequency, and pattern of noise; the amount of background noise present before the intruding noise; and the nature of work or human activity that is exposed to the noise source.<sup>[1]</sup>

The major impacts of noise are Annoyance, Physiological effects, loss of hearing, Human performance, Nervous system, sleeplessness and Damage to material.

#### **2.4. Factors Affecting Noise Level**

Several factors affect the amount of noise emitted by traffic:<sup>[14]</sup>

**Vehicle type:** heavy vehicles (trucks and buses), and vehicles with faulty exhaust systems tend to produce high noise levels.

**Engine type:** Older diesel engines tend to be the noisiest, followed by gasoline and natural gas, hybrid, and electricity vehicles being quiet test.

**Traffic speed, stops and inclines:** Lower speeds tend to produce less engine, wind and track noise. Engine noise is greatest when a vehicle is accelerating or climbing an incline. Aggressive driving, with faster acceleration and harder stopping, increases noise.

**Distance and barriers:** Noise is most audible when traveling along direct line-of-sight. Barriers, such as walls, berms, trees, hills, sound resistant design features such as double-paned windows, or buildings that break the line-of-sight between the source and the receiver greatly reduce noise levels from the source because sound can reach the receiver only by bending over the top of the barrier (diffraction).

#### **2.5. Descriptors of Railroad Noise**

The following single-number descriptors are used for transit-noise measurements, computations, and assessment.<sup>[3]</sup>

##### **A-weighted Sound Level**

The basic noise unit for transit noise is the A-weighted Sound Level. It describes a receiver's noise at any moment in time and is read directly from noise-monitoring equipment, with the "weighting switch" set on "A."

##### **Maximum Sound Level ( $L_{max}$ )**

As a transit vehicle approaches, passes by, and then recedes into the distance, the A-weighted sound level rises, reaches a maximum, and then fades into the background noise. The maximum A-weighted sound level reached during this passby is called the Maximum Sound Level, abbreviated here as " $L_{max}$ ." For noise compliance tests of

transient sources, such as moving transit vehicles under controlled conditions with smooth wheel and rail conditions,  $L_{max}$  is typically measured with the sound level meter's switch set on "fast." However, for tests of continuous or stationary transit sources, and for the general assessment of transit noise impact, it is usually more appropriate to use the "slow" setting. When set on "slow," sound level meters ignore some of the very transient fluctuations, which are unimportant to people's overall assessment of the noise.

However,  $L_{max}$  is not used as the descriptor for transit environmental noise impact assessment for several reasons.  $L_{max}$  ignores the number and duration of transit events, which are important to people's reaction to noise, and cannot be totalled into a one-hour or a 24-hour cumulative measure of impact.

### **Sound Exposure Level (SEL)**

This is the total amount of sound energy that enters the receiver's ears (or the measurement microphone) during the vehicle passby. The quantitative measure of the noise exposure for single noise events is the Sound Exposure Level. The fact that SEL is a cumulative measure means that (1) louder events have greater SELs than do quieter ones, and (2) events that last longer in time have greater SELs than do shorter ones. People react to the duration of noise events, judging longer events to be more annoying than shorter ones, assuming equal maximum A-Levels.

SEL is used as the cumulative measure of each single transit-noise event because unlike  $L_{max}$ : (1) SEL increases with the duration of a noise event, which is important to people's reaction, (2) SEL, therefore, allows a uniform assessment method for both transit-vehicle passbys and fixed-facility noise events, and (3) SEL can be used to calculate the one-hour and 24-hour cumulative descriptors discussed below.

### **Hourly equivalent sound level ( $L_{eq}(h)$ )**

The descriptor for cumulative one-hour exposure is the Hourly Equivalent Sound Level, abbreviated here as " $L_{eq}(h)$ ." It is an hourly measure that accounts for the moment-to-moment fluctuations in A-weighted sound levels due to all sound sources during that hour, combined.

Hourly  $L_{eq}$  is adopted as the measure of cumulative noise impact for non-residential land uses (those not involving sleep) because: (1)  $L_{eq}$ 's correlate well with speech interference in conversation and on the telephone – as well as interruption of TV,

radio and music enjoyment, (2)  $L_{eq}$ 's increase with the duration of transit events, which is important to people's reaction, (3)  $L_{eq}$ 's take into account the number of transit events over the hour, which is also important to people's reaction.

### **Day-Night Sound Level ( $L_{dn}$ ): The Cumulative 24-Hour Exposure from All Events**

The descriptor for cumulative 24-hour exposure is the Day-Night Sound Level, abbreviated here as " $L_{dn}$ ." It is a 24-hour measure that accounts for the moment-to-moment fluctuations in A-Levels due to all sound sources during 24 hours, combined. The night time noise (10pm to 7pm) is increased by 10 decibels before totalling.

$L_{dn}$  is adopted as the measure of cumulative noise impact for residential land uses (those involving sleep), because: (1)  $L_{dn}$  correlates well with the results of attitudinal surveys of residential noise impact, (2)  $L_{dn}$ 's increase with the duration of transit events, which is important to people's reaction, (3)  $L_{dn}$ 's take into account the number of transit events over the full twenty-four hours, which is also important to people's reaction, (4)  $L_{dn}$ 's take into account the increased sensitivity to noise at night, when most people are asleep, (5)  $L_{dn}$ 's allow composite measurements to capture all sources of community noise combined, (6)  $L_{dn}$ 's allow quantitative comparison of transit noise with all other community noises.

## **2.6. Railway Noise Impact Assessment<sup>[1]</sup>**

### **General Assessment Procedure**

Depending on the type of development, the following steps would normally be addressed in the assessment:

- Measurement of existing rail noise
- Prediction of rail noise
- Noise mitigation procedures
- Measurements to verify the accuracy of noise predictions.

Note that, while the first three steps would be presented in a single assessment report, post-construction verification measurements would normally be conducted sometime after the initial rail noise and vibration assessment and presented in a separate report.

### **Evaluation Distance**

The impact of noise should be predicted and considered in the design if noise sensitive developments are proposed within the following *evaluation distances*:

- 35 metres from a tram line
- 180 metres from a train line

If noise sensitive developments are proposed at a sufficient distance from rail lines or vice versa, it is considered as rail noise impacts will be minimal, and therefore detailed consideration of these impacts during the design of the project is not required. As noted previously, these distances indicate the need to investigate impacts. Developments proposed within these distances may be acceptable, however a consideration of noise from rail operations is required, and where necessary appropriate mitigation actions should be implemented. Noise sensitive receivers at distances greater than the above *evaluation distances* from the nearest railway line are deemed to be sufficiently far from the railway such that noise and vibration impacts arising from a modern, well-designed rail system will be minimal.

### **Background Noise**

Measurements of the existing rail noise at or near sensitive receiver locations would normally be expected for the assessment of an upgrade of an existing railway line or of a new noise sensitive development adjacent to an existing line. The purpose of the measurements is to characterise the existing exposure of sensitive receivers or the existing exposure of the site of a proposed sensitive development. The measurements will also allow rail noise predictions to be validated to ensure an acceptable level of accuracy.

Where a large number of sensitive receiver locations are adjacent to the rail corridor and need to be included in the assessment, it will not be practical to measure existing rail noise at every location. In these cases, the existing conditions at all sensitive receiver locations should be predicted based on measurements conducted at a number of representative sites. For example, the nearest residential location to the railway line among a group of residences would normally provide a suitable monitoring site

### **Standard Modelling Factor**

Standard modelling factors that should be conservatively adopted for rail noise prediction are:

- Use worst-case weather conditions
- Use atmospheric conditions at 15°C and 70% humidity
- Assume hard ground between the rail line and noise sensitive receivers.

Where alternative modelling factors are used, justification is to be given for the selection of the alternative factors.

### **Documentation**

This section outlines the information typically required in the documentation for rail noise assessments:

1. The location of rail corridor and of all relevant sensitive receivers, preferably depicted on aerial imagery or an appropriately scaled and detailed site plan
2. Project extents (for new or upgraded railway lines only)
3. Type of sensitive receivers and a description of the land use
4. Details of any existing rail noise measurements, including measurement location, time, duration, weather conditions, equipment used, type/number of rail vehicles measured and operating conditions of vehicles during measurements
5. Measured or predicted existing rail noise levels at sensitive receivers
6. Noise criteria for sensitive receivers
7. Predicted noise levels at the sensitive receivers, as well as noise contour maps for relevant assessment periods
8. Details of methodology/algorithm used to predict noise levels, including weather conditions and other input data, with details of the validation carried out, and justification of weather conditions and input data used.
9. Rail vehicle volumes, vehicle types and any vehicle specific noise mitigation measures assumed in the predictions
10. Comparison of predicted levels to the criteria, in particular highlighting any non-compliance with the criteria
11. Any expected noise events of annoying character, such as wheel and brake squeal, and appropriate design measures undertaken to mitigate the likelihood of these events
12. Details of recommended noise mitigation measures required to achieve the criteria at sensitive receivers, if required, including predicted reductions due to mitigation measures
13. Reasons why mitigation measures at the source or along the transmission path have been discounted, if relevant.

## **2.7. Mitigation Measures of Railways Noise**

There are a number of physical factors involved in determining how noise is propagated and how much reaches the receiver. Moreover, noise levels at sensitive receptors can be minimised by reducing the source, ensuring adequate distance between the source and receiver and using barriers between the source and receiver. To determine the degree of control required, it is usual to calculate or measure the sound pressure level close to the source and know the desired end-point. To do this, we need to calculate the attenuation provided by the environment at the sensitive location and the additional attenuation required. Generally, It is nearly always more cost-effective and easy for installation to consider noise reduction at the design stage than the later modification. [1]

### **Mitigation at the source**

Particular attention should be paid to the proposed rail line's location in relation to existing and planned residential areas and the possibility of using existing topographical features to mitigate noise. Keeping rail vehicles and tracks well maintained is important and this should be given high priority in any mitigation strategy. Other types of sources that should be given high priority are those with annoying characteristics (e.g. tonality, impulsiveness). These include wheel squeal, brake squeal and the noise from track joints and turn outs as they generally evoke a strong community reaction.

### **Mitigation in transmission**

The mitigation of noise from rail operations along the transmission path is most commonly achieved through the installation of noise barriers along the rail corridor. Noise barriers can take a variety of forms, ranging from walls or fences through to earth mounds and cuttings for the railway line, and are most effective when installed as close as possible to the noise source or to the receiver. To provide noise reduction of a source, a barrier must at least break the line-of-sight between the source and the receiver.

### **Mitigation at the receiver**

Complementary management at the point of impact may be required. This might be due to the closeness of affected premises or physical, operational and economic constraints. Building design, layout and construction techniques should be applied. Where a proposed rail development will affect an existing or approved development, treatment of buildings at the property (e.g. insulation, window-glazing for noise reduction, upgrading construction) can be considered as an option to mitigate noise.

### **Mitigation through land use planning**

For new noise sensitive development adjacent to rail corridors, appropriate planning measures should be implemented. For instance, consideration should be given to locating sensitive buildings as far from the rail corridor as possible within the property boundary, as well as locating sensitive rooms on the furthest side of the building from the rail corridor to provide shielding.

### **Mechanisms to Select Appropriate Mitigation Measures**

Among all counter measures, mitigation measures installed at the source are preferred as they typically provide the greatest protection to sensitive receivers, provide benefit to a greater number of receivers, are generally more cost effective and can remove or reduce the need for mitigation measures along the path or at the receivers themselves.

Mitigation along the transmission path, such as the installation of a noise barrier, is preferable to mitigation at the receiver as it will provide protection to both outdoor and indoor areas of sensitive receivers, and to a greater number of receivers.

Mitigation at the receiver is normally the least desirable option, especially where the treatments consist of upgrades to the building facade as protection is only provided to indoor areas. When determining the appropriate noise mitigation measures, if required as part of an assessment, it is important that consideration is given to how reasonable and practicable the proposed mitigation measures are. For new noise sensitive developments adjacent to railway lines, appropriate planning of the development is an important factor in noise mitigation. If additional noise reduction is still required after appropriate planning of the development has been undertaken, then mitigation treatments at the receiver are generally the only option as there is no control over the railway line and its operations or over the rail corridor.

## CHAPTER THREE

### STUDY METHODOLOGY

#### 3.1. General Methodologies and Procedures Used in Assessment

The following general procedures are adopted in the assessing Addis Ababa Light Rail transit induced noise level.

##### **Step-1: Describe the Railway Network**

Necessary points detailed for the railway network are;

- Speed profile of the train running on the rail line
- Gradient profile of the track at different section
- Traction system of the railway system
- Type of service, i.e. passenger or freight
- Track type, ballasted or slab
- Structures like bridges
- Characteristics of rolling stock like braking system
- Number of trains in a single locomotive
- Train Scheduling and Head time of train operation
- Train length
- Service or operation time
- Location of the alignment
- Horizontal curvature of the alignment
- Rail condition

##### **Step -2: Site Survey**

After describing the railway network and its operations in depth, site survey is done to have the following information's;

- Location of susceptible structures like schools, hospitals, assembly halls, theatre rooms, cinemas, residential buildings etc. found within the evaluation distance i.e. 35 meter from the tram line.
- Speed and gradient profile of railway network alongside those susceptible buildings.
- Characteristics of railway network along those susceptible buildings is identified

- Natural and artificial barriers between the railway line and susceptible buildings are identified and detailed
- Ground conditions between susceptible structures and rail line is surveyed to know the absorption or reflection behaviour
- Nature of surrounding or nearby buildings is considered

### **Step-3: Background or Ambient Noise Level**

First, the background noise environment associated with the railway operations at the specific site location should be described.

These descriptions include the following points;

- Road network description at the required location
- Explanation of topography and nature of the surrounding land uses
- Community type
- Average census tract population density, number of people per square kilometre

Due to the absence of adequate justification of background noise levels through ambient noise monitoring, the background noise is estimated by the use of known base line levels of previously conducted noise studies or approximating values from table in **Appendix B**.

### **Spep-4: Determine the Noise Induced from a Railway Project**

The noise level is quantified at the required susceptible buildings which are described in the above procedures. As explained before, the assessment is done using mathematical Quantification methods. For this purpose, methods are refined from different literatures. The overall mathematical procedures and formulas applied for this assessment are found in **Appendix C**.

In general, the following stepwise works are done for the assessment purpose;

- a. Addis Ababa light rail transit line is divided in to different segment based on Sensitive Receptors Location which are found within the evaluation distance i.e. 35m from the tram line and speed profile, gradient and land use characteristics is defined for each location.
- b. For each Location of receptor, the level of noise at a distance of 25m from near side rail head is determined as a function of speed.
- c. Adjustments are applied to fit the actual cases by considering corrections;
  - For number of vehicles

- For source enhancement
  - For gradient, ballast
  - For different track and track support structure
  - For distance location, Air absorption
  - For Air absorption
  - Ground condition /obstructed or un obstructed/
  - For barriers and buildings, parallel noise barrier
  - Embankment and cuttings, retained cutting
- d. By applying corrections determined in part c, the reference sound exposure level can be converted in to an equivalent sound level  $L_{Aeqs}$  taking in to account the period over which the noise level is to be determined and the total number of trains of each type over the appropriate period.
- e. Finally the total  $L_{Aeqs}$  is calculated for the railway.

By following these procedures, we can reach at the required noise level from railways operation.

#### **Step-5: Carryout an Initial Impact Assessment**

The degree of impact can be estimated using ambient noise level determined in step-3 and project noise level in step-4. In order to do this the noise impact criteria found in **Appendix D part -2** is used.

#### **Step-6: Assessment of Impacts**

After getting the level of noise at a certain location, discussion is made using this result and railway noise criteria for different susceptible structures or buildings.

The railway noise criteria's applicable for this assessment are found in **Appendix D**.

#### **Step-6: Counter Measures**

From the impact assessment result in step-5 and 6, conditions where the noise criteria are exceeded can be identified. For these situations different options to mitigate the adverse noise levels can be adopted.

## CHAPTER FOUR

### ANALYSIS

The analysis and evaluation part contains list and descriptions of sensitive buildings within the evaluation distance in AALRT, an estimation of back ground noise, level of noise induced from the railway operation and norm of impacts due to the railroad.

#### 4.1. Data Collected on Sensitive Receptors

Table-4.1: Description of Sensitive Receptors with in the Evaluation Distance

No.	Receptors	Location (b/n stations)	Description	Railway Track	Existing Barrier	Train Speed (Km/H)
1	Residential Building-1	Kality - Abo mazoriya	Ground Mud Villas	Under retained cutting, Straight & Ballasted	Retained cutting	30
2	Saris Medium Clinic	Saris – Adey abebe	Ground RC- building	Elevated by 0.4m from ground, Straight & Ballasted	No	35
3	Ethio-Indian Friendship School	Adey abebe- Nefas Silk 1	Ground RC- building	Elevated by 0.4m from ground, Straight & Ballasted	Fence	40
4	Saint Joseph Church	Nefas Silk 1 – Nefas Silk 2	Ground RC- building	Elevated by 0.52m from ground, Straight & Ballasted	No	50
5	Nefas Silk Technic College	Nefas Silk 1 – Nefas Silk 2	Ground RC- building	Elevated by 0.52m from ground, Straight & Ballasted	Fence	50
6	Sebstie Negasa Primary School	Nefas Silk 1 – Nefas Silk 2	Ground RC- building	Elevated by 0.52m from ground, Straight & Ballasted	Fence	50
7	Nefas Silk Medium Clinic	Nefas Silk 2 – Lancha	Ground RC- building	Elevated by 2.8m (embankment) from ground, Straight & Ballasted	Fence	50
8	Saint Joseph Higher Clinic	Nefas Silk 2 – Lancha	Ground RC- building	Elevated by 4.5m (Bridge) from ground, slab track	Homes	50

9	<b>Nave Hotel and Tourism Institute</b>	Nefas Silk 2 – Lancha	At 5 <sup>th</sup> floor of G+6 RC-Building	Elevated by 5.4m (bridge) from ground, Straight & slab	Homes	40
10	<b>Senay Medical Centre</b>	Nefas Silk 2 – Lancha	Ground RC-building	Elevated by 3.2m(bridge) from ground, Straight & slab	Fence	35
11	<b>Kety Saint Gabriel Higher Clinic</b>	Meshualekiya – Stadium	Ground RC-building	Elevated by 0.35m from ground, Straight & ballasted	no	35
12	<b>Betezata Hospital</b>	Stadium-Leghar	G+8 floor RC-Building	Elevated by 5.5m (bridge) from ground, Straight & slab	No	30
13	<b>Residential Building-2</b>	Leghar – Mexico	At 3 <sup>rd</sup> floor of G+6 RC Building	Elevated by 5.5m(bridge) from ground, Straight & slab	No	35
14	<b>Catering and Tourism Training Institute</b>	Mexico – Tegbareid	Ground RC-building	Elevated by 5.5m (bridge)from ground, Straight & slab	No	30
15	<b>A.A Tegbareid Poly Technic College</b>	Mexico – Tegbareid	Different buildings	Elevated by 5.8m(bridge) from ground, Straight & slab	No	35
16	<b>Federal Police Hospital</b>	Tegbareid-Saint Lideta	Different Buildings	Elevated by 6.5m(bridge) from ground, slab track	No	45
17	<b>Saint Lideta Mariyam church</b>	Tegbareid-Saint Lideta	Ground RC-building	Elevated by 7m(bridge) from ground, slab track	No	40
18	<b>EIABC</b>	Saint Lideta Coca Cola	Different Buildings	Elevated by 0.61m from ground, Straight & Ballasted	Fence	40
19	<b>Armed Forces Hospital</b>	Coca cola – Torhayloch	Different Buildings	Elevated by 0.32m from ground, Straight & Ballasted	Fence	30

20	<b>Saint Estifanos Church</b>	Stadium – Saint Estifanos	Ground RC-building	Elevated by 6m(bridge) from ground, Straight & slab	No	30
21	<b>Saint Ourael Church</b>	Saint Urael – Haya Hulet 2	Ground RC-building	Under retained cutting, Straight & Ballasted	Retained cutting	30
22	<b>Admas University College</b>	Lem Hotel – Megegnagna	G+2 RC-Building	Elevated by 0.4m from ground, Straight & Ballasted	Fence	45
23	<b>Tsinu Medium Clinic</b>	Gurdshola1 – Gurdshola2	Ground RC-building	Elevated by 0.4m from ground, Straight & Ballasted	No	50
24	<b>Sealite Mihret Saint Mariyam Church</b>	Gurdshola1-Sira Amerar	Ground RC-building	Elevated by 0.3m from ground, Straight & Ballasted	Fence	45
25	<b>Ethiopian Civil Service University</b>	Sira Amerar – Civil Service	Different Buildings	Elevated by 0.32m from ground, Straight & Ballasted	Fence	40
26	<b>Saint Michael Church</b>	Civil Service-Saint Michael	Ground RC-building	Elevated by 0.32m from ground, Straight & Ballasted	Fence	40
27	<b>Residential Buildings-3</b>	CMC – Meri	G+2 RC-Buildings	Elevated by 0.35m from ground, Straight & Ballasted	Fence	50
28	<b>Doctor Bekele Lema Clinic</b>	CMC – Meri	Ground RC-building	Elevated by 0.5m from ground, Straight & Ballasted	No	40
29	<b>EL-EYOB medium Clinic</b>	Meri Ayat	Ground RC-building	Elevated by 1.6m (embankment) from ground, Straight & Ballasted	No	40

#### 4.2. Train Scheduling in AALRT

Using Time table Train drive given below, the number of pass by events occurred through the railway network adjacent to each receptor in both track is equal, which is 120.

Table 4.2: Train drive Scheduling in Addis Ababa light rail transit

EW-Line Route Table(For AALRT-02#Timetable)																			
Shift	Attendance Time	Attendance Location	Train NO.	EW2 Takeover /Outbound Time	Departure Time	Train NO.	Departure Time	Train NO.	Departure Time	Train NO.	Departure Time	Train NO.	Departure Time	Train NO.	Departure Time	EW2 Handover /Inbound Time	Off Duty Time	Off Duty Location	
M01	4:20	DCC Office	10102	5:00:00	no stopped until arrived at EW22 on down line and put into service	10103	6:00:00	10204	7:30:00	10205	8:26:00					9:32:19	9:52	EW2 Office	
M02	4:40	DCC Office	10202	5:20:00		10203	6:20:00	10304	7:45:00	10305	8:41:00						9:47:19	10:07	EW2 Office
M03	5:00	DCC Office	10302	5:40:00		10303	6:40:00										7:47:19	8:07	EW2 Office
M04	5:15	DCC Office	10402	5:55:00	6:00:00	10403	7:02:00									8:02:19	8:22	EW2 Office	
M05	5:35	DCC Office	10502	6:15:00	6:20:00	10503	7:23:00									8:32:19	8:52	EW2 Office	
M06	5:55	DCC Office	10602	6:35:00	6:40:00	10603	7:45:00									8:47:19	9:07	EW2 Office	
M07	5:55	DCC Office	by 10602 to EW2, takeover on	6:35:00	6:40:00	10104	7:00:00	10105	8:01:00							9:02:19	9:22	EW2 Office	
M09	6:30	DCC Office	10702	7:10:00	7:15:00	10703	8:11:00									9:17:19	9:37	EW2 Office	
M09	7:30	DCC Office	10802	8:10:00	0.34375	10803	9:10:00									10:17:19	10:37	EW2 Office	
N01	7:47	EW2 Office	10404	8:02:19	8:00:00	10405	8:55:00	10108	11:00:00	10109	11:55:00	10310	13:45:00	10311	14:40:00	15:47:19	16:07	EW2 Office	
N02	8:17	EW2 Office	10504	8:32:19	8:30:00	10505	9:25:00	10706	11:15:00	10707	12:10:00	10410	14:00:00	10411	14:55:00	16:02:19	16:22	EW2 Office	
N03	8:32	EW2 Office	10604	8:47:19	8:45:00	10605	9:40:00	10208	11:30:00	10209	12:25:00	10808	14:15:00	10809	15:10:00	16:17:19	16:37	EW2 Office	
N04	8:47	EW2 Office	10106	9:02:19	9:00:00	10107	9:55:00	10308	11:45:00	10309	12:40:00	10510	14:30:00	10511	15:25:00	16:32:19	16:52	EW2 Office	
N05	9:02	EW2 Office	10704	9:17:19	9:15:00	10705	10:10:00	10408	12:00:00	10409	12:55:00	10610	14:45:00	10611	15:40:00	16:47:19	17:07	EW2 Office	
N06	9:17	EW2 Office	10206	9:32:19	9:30:00	10207	10:25:00	10806	12:15:00	10807	13:10:00	10112	15:00:00	10113	15:55:00	17:02:19	17:22	EW2 Office	
N07	9:32	EW2 Office	10306	9:47:19	9:45:00	10307	10:40:00	10508	12:30:00	10509	13:25:00	10710	15:15:00	10711	16:10:00	17:17:19	17:37	EW2 Office	
N08	9:47	EW2 Office	10406	10:02:19	10:00:00	10407	10:55:00	10608	12:45:00	10609	13:40:00	10212	15:30:00	10213	16:25:00	17:32:19	17:52	EW2 Office	
N09	10:02	EW2 Office	10804	10:17:19	10:15:00	10805	11:10:00	10110	13:00:00	10111	13:55:00	10312	15:45:00	10313	16:40:00	17:47:19	18:07	EW2 Office	
N10	10:17	EW2 Office	10506	10:32:19	10:30:00	10507	11:25:00	10708	13:15:00	10709	14:10:00	10412	16:00:00	10413	16:55:00	18:02:19	18:22	EW2 Office	
N11	10:32	EW2 Office	10606	10:47:19	10:45:00	10607	11:40:00	10210	13:30:00	10211	14:25:00	10810	16:15:00	10811	17:10:00	18:17:19	18:37	EW2 Office	
E01	16:17	EW2 Office	10512	16:32:19	16:00:00	10513	17:25:00	10714	19:20:00	10715	20:20:00	by 10815	21:20:00			22:18:35	22:38	DCC Office	
E02	16:32	EW2 Office	10612	16:47:19	16:46:00	10613	17:40:00	10316	19:40:00	10317	20:40:00	by 10815	21:20:00			22:18:35	22:38	DCC Office	
E03	16:47	EW2 Office	10114	17:02:19	17:00:00	10115	17:55:00	10416	20:00:00	10417	21:00:00	by 10815	21:20:00			22:18:35	22:38	DCC Office	
E04	17:02	EW2 Office	10712	17:17:19	17:15:00	10713	18:10:00	10814	20:20:00	10815	21:20:00					22:18:35	22:38	DCC Office	
E05	17:17	EW2 Office	10214	17:32:19	17:30:00	10215	18:25:00									19:24:35	19:44	DCC Office	
E06	17:32	EW2 Office	10314	17:47:19	17:45:00	10315	18:40:00	10616	20:40:00	10617	21:40:00					22:38:35	22:58	DCC Office	
E07	17:47	EW2 Office	10414	18:02:19	18:00:00	10415	18:55:00	10118	21:00:00	10119	22:00:00					22:58:35	23:18	DCC Office	
E08	18:02	EW2 Office	10812	18:17:19	18:15:00	10813	19:10:00	10716	21:20:00	10717	22:20:00					23:03:00	23:23	DCC Office	
E09	18:17	EW2 Office	10514	18:32:19	18:30:00	10515	19:25:00									20:24:36	20:44	DCC Office	
E10	18:32	EW2 Office	10614	18:47:19	18:45:00	10615	19:40:00	10318	21:40:00	10319	22:32:56					23:16:00	23:36	DCC Office	
E11	18:47	EW2 Office	10116	19:02:19	19:00:00	10117	20:00:00	10418	22:00:00	10419	22:53:01					23:35:41	23:55	DCC Office	

### 4.3. Background Noise

The existing noise exposure level for all sensitive structures are made based on nearby major roadways. The reason behind this is the existence of roadways, producing more noise than local street and community activities.

The estimation is performed based on base line noise determination found in Appendix-B and the results are as follows in the table.

N.B.

- The roadways have more than four lanes, therefore, they classified under “INTERSTATE”
- Average distance from the receptor to nearby roadways is taken.

**Table-4.3: Estimated Background Noise Level**

No.	Sensitive Structures	Average distance from Roadways(m)	Background Noise Level, dB		
			Leq,15h	Leq,1h	Ldn
1	Residential Building-1	32	65	-	65
2	Saris Medium Clinic	28	-	70	70
3	Ethio-Indian Friendship School	31	-	65	-
4	Saint Joseph Church	35	-	65	-
5	Nefas Silk Technic College	35	-	65	-
6	Sebstie Negasa Primary School	35	-	65	-
7	Nefas Silk Medium Clinic	25	-	70	70
8	Saint Joseph Higher Clinic	25	-	70	70
9	Nave Hotel and Tourism Institute	36	-	65	-
10	Senay Medical Centre	30	-	70	70
11	Kety Saint Gabriel Higher Clinic	29	-	70	70
12	Betzata Hospital	20	-	70	70
13	Residential Building-2	20	70	-	70
14	Catering and Tourism Training Institute	35	-	65	-
15	A.A Tegbareid Poly Technic College	24	-	70	-

16	Federal Police Hospital	24	-	70	70
17	Saint Lideta Mariyam church	25	-	70	-
18	EIABC	31	-	65	-
19	Armed Forces Referral and Teaching Hospital	33	-	65	65
20	Saint Estifanos Church	22	-	70	-
21	Saint Ourael Church	23	-	70	-
22	Admas University College	34	-	65	-
23	Tsinu Medium Clinic	31	-	65	65
24	Sealite Mihret Saint Mariyam Church	33	-	65	-
25	Ethiopian Civil Service University	31	-	65	-
26	Saint Michael Church	31	-	65	-
27	Residential Buildings-3	34	65	-	65
28	Doctor Bekele Lema Clinic	21	-	70	70
29	EL-EYOB medium Clinic	21	-	70	70

#### 4.4. Project Induced Noise

Addis Ababa Light Rail Transit operation time is from 6:00AM to 10:00PM, so that assessment is made for the day condition alone.

The noise exposure level induced from AALRT to each receptor is made using the procedures explained in Appendix – C.

##### 4.4.1. Sample Calculations

#### 1. Residential Building -1

- Location = between AYAT and ABO MAZORIYA Station
- Rail Joint = track jointed/bolted
- Track type = ballasted double track
- Section= retained cutting
- Number of train per day = 120 in both track

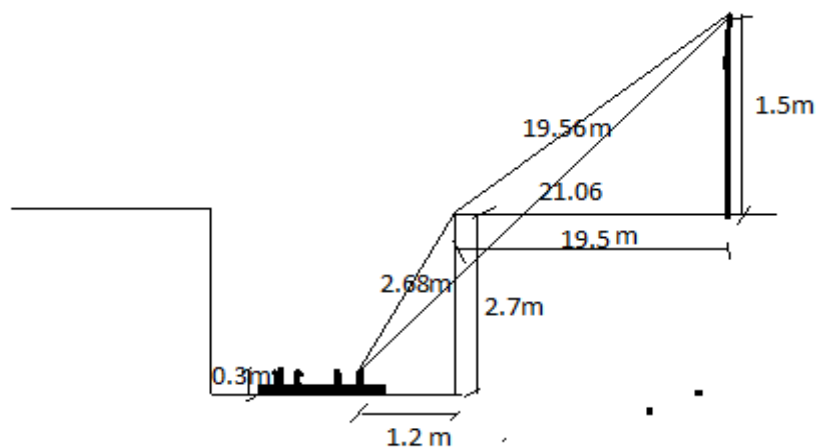
**Figure 4.1: Residential Building found between AYAT and ABO MAZORIYA station**

❖ **Reference Noise Level at 25 meter**

- $SEL_{ref} = 31.2 + 20\log_{10} 30 = 60.74\text{dB}$
- Correction,  $C = +14.9$  (for disc braked light rail)
- Then,  $SEL_{ref} = 60.74 + 14.9 = 75.64\text{dB}$

❖ **Corrections**

- Number of trains,  $N = 2$

$$C1 = 10\log_{10} 2 = +3\text{dB}$$

- Source Enhancement

$$C2 = +2.5 \text{ (jointed Track)}$$

- Distance correction

$$C3 = -10\log_{10}\left(\frac{21.06}{25}\right) = 0.74\text{Db}$$

- Air Absorption Correction

$$C4 = 0.2 - 0.008(21.06) = 0\text{dB}$$

- Retained Cutting

$$\delta = 2.68 + 19.56 - 21.06 = 1.18\text{m}$$

For  $0 < \delta < 2.5$ , shadow zone:

$$C5 = -7.75\log_{10}(5.2 + 203 * 1.18) = -18.5\text{dB}$$

- Reflection Correction

$$C6 = -0.5 * 2.7 = -1.35\text{dB}$$

- Façade Effect

$$C7 = +2.5\text{dB}$$

- Then, Total corrections,

$$C = \sum_{i=1}^7 Ci = -11.11\text{dB}$$

#### Sound Exposure Level, SEL<sub>i</sub>

$$\text{SEL}_i = \text{SEL}_{\text{ref}} + C = 75.46 - 11.11 = 64.35\text{dB}$$

#### ❖ Convert SEL to Leq,T

$$L_{\text{Aeq,day}} = 10\log_{10}\left[\frac{1}{(15*60*60)}\left(120 * 10^{\frac{64.35}{10}}\right)\right] = \mathbf{36\text{dB}}$$

$$L_{\text{DN}} = \log_{10}\frac{1}{15}\left[\left(15 \times 10^{\frac{36}{10}}\right)\right] = \mathbf{36\text{dB}}$$

## 2. Kety Saint Gebriel Higher Clinic

- Location = between Meshualekiya and Stadium station
- Rail Joint = track jointed/bolted
- Track type = ballasted double track
- Section= on fill(embankment)
- Number of train per day = 120 in both track
- Number of train per hour of peak operation = 8 in both track

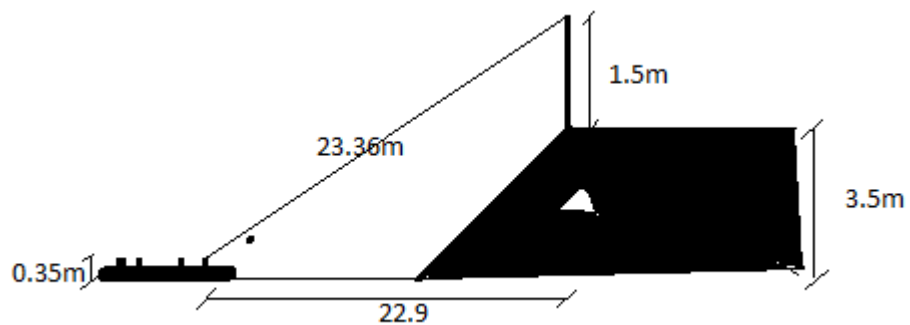
**Figure 4.2: Kety Saint Gabriel Higher Clinic MESHUALEKIYA and STADIUM station**

❖ **Reference Noise Level at 25 meter**

- $SEL_{ref} = 31.2 + 20\log_{10} 30 = 62.1\text{dB}$
- Correction,  $C = +14.9$  (for disc braked light rail)
- Then,  $SEL_{ref} = 62.1 + 14.9 = 77\text{dB}$

❖ **Corrections**

- Number of trains,  $N = 2$
- $$C1 = 10\log_{10} 2 = +3\text{dB}$$

- Source Enhancement  

$$C2 = +2.5 \text{ (jointed Track)}$$
- Distance correction  

$$C3 = -10\log_{10}\left(\frac{23.36}{25}\right) = 0.3\text{dB}$$
- Air Absorption Correction  

$$C4 = 0.2 - 0.008(23.36) = 0\text{dB}$$
- Ballast  

$$C5 = -1.5\text{dB}$$
- Façade Effect  

$$C6 = +2.5\text{Db}$$
- Then, total corrections,  

$$C = \sum_{i=1}^6 Ci = 6.8\text{dB}$$

#### Sound Exposure Level, SEL<sub>i</sub>

$$\text{SEL}_i = \text{SEL}_{\text{ref}} + C = 77 + 6.8 = 83.8\text{dB}$$

#### ❖ Convert SEL to Leq,T

$$L_{\text{Aeq,day}} = 10\log_{10}\left[\frac{1}{(15*60*60)} (120 * 10^{\frac{83.8}{10}})\right] = \mathbf{57\text{dB}}$$

$$L_{\text{Aeq,1h}} = 10\log_{10}\left[\frac{1}{(1*60*60)} (8 * 10^{\frac{83.8}{10}})\right] = \mathbf{57\text{dB}}$$

#### 4.4.2. Summary of Results

Project induced noise levels for all sensitive buildings are calculated in the similar fashions as above and results are tabulated as follows.

N.B.

- The number of pass-by events, N, occurred during the day time is 120.
- The number of pass by events occurred during the hourly operation event is 8.

Table 4.4: Project Induced Noise Levels

No.	Sensitive Buildings	Project Noise Levels, dB		
		Leq,15h	Leq,h	Ldn
1	Residential Building-1	36	-	36
2	Saris Medium Clinic	-	55	55
3	Ethio-Indian Friendship School	-	41	-
4	Saint Joseph Church	-	57	-
5	Nefas Silk Technic College	-	44	-
6	Sebstie Negasa Primary School	-	53	-
7	Nefas Silk Medium Clinic	-	47	47
8	Saint Joseph Higher Clinic	-	52	52
9	Nave Hotel and Tourism Institute	-	57	-
10	Senay Medical Centre	-	46	46
11	Kety Saint Gabriel Higher Clinic	-	57	57
12	Betzata Hospital	-	55	55
13	Residential Building-2	56	-	56
14	Catering and Tourism Training Institute	-	54	-
15	A.A Tegbareid Poly Technic College	-	56	-
16	Federal Police Hospital	-	58	58
17	Saint Lideta Mariyam church	-	57	-
18	EIABC	-	45	-
19	Armed Forces Referral and Teaching Hospital	-	42	42
20	Saint Estifanos Church	-	54	-
21	Saint Ourael Church	-	45	-
22	Admas University College	-	47	-
23	Tsinu Medium Clinic	-	59	59
24	Sealite Mihret Saint Mariyam Church	-	44	-
25	Ethiopian Civil Service University	-	56	-
26	Saint Michael Church	-	38	-
27	Residential Buildings-3	58	-	58
28	Doctor Bekele Lema Clinic	-	59	59
29	EL-EYOB medium Clinic	-	57	57

## CHAPTER FIVE

### EVALUATION

#### 5.1. EVALUATION OF PROJECT NOISE BASED ON EXISTING NOISE

First the sensitive receptors are categorised based on land use categories and metrics for transit noise impact criteria found in Appendix-D, A.3 and the evaluation of project noise impact is done using noise impact criteria for transit projects found in Appendix-D-1.

**Table-5.1: Evaluation of Project Noise Based on Existing Noise**

No.	Sensitive Receptor	Category	Background Noise, dB		Project Noise, dB		Impact
			Leq, h	Ldn	Leq,h	Ldn	
1	Residential Building-1	2	-	65	-	36	No impact
2	Saris Medium Clinic	2	-	70	-	55	No impact
3	Ethio-Indian Friendship School	3	65	-	41	-	No impact
4	Saint Joseph Church	3	65	-	57	-	No impact
5	Nefas Silk Technic College	3	65	-	44	-	No impact
6	Sebstie Negasa Primary School	3	65	-	53	-	No impact
7	Nefas Silk Medium Clinic	2	-	70	-	47	No impact
8	Saint Joseph Higher Clinic	2	-	70	-	52	No impact
9	Nave Hotel and Tourism Institute	3	65	-	57	-	No impact
10	Senay Medical Centre	2	-	70	-	46	No impact
11	Kety Saint Gabriel Higher Clinic	2	-	70	-	57	No impact
12	Betzata Hospital	2	-	70	-	55	No impact
13	Residential Building-2	3	-	70	-	56	No impact
14	Catering and Tourism Training Institute	3	65	-	54	-	No impact
15	A.A Tegbareid Poly Technic College	3	70	-	56	-	No impact
16	Federal Police Hospital	2	-	70	-	58	No impact
17	Saint Lideta Mariyam church	3	70	-	57	-	No impact
18	EIABC	3	65	-	45	-	No impact
19	Armed Forces Referral and Teaching Hospital	2	-	65	-	42	No impact

20	Saint Estifanos Church	3	70	-	54	-	No impact
21	Saint Ourael Church	3	70	-	45	-	No impact
22	Admas University College	3	65	-	47	-	No impact
23	Tsinu Medium Clinic	2	-	65	-	59	No impact
24	Sealite Mihret Saint Mariyam Church	3	65	-	44	-	No impact
25	Ethiopian Civil Service University	3	65	-	56	-	No impact
26	Saint Michael Church	3	65	-	38	-	No impact
27	Residential Buildings-3	2	-	65	-	58	No impact
28	Doctor Bekele Lema Clinic	2	-	70	-	59	No impact
29	EL-EYOB medium Clinic	2	-	70	-	57	No impact

## 5.2. EVALUATION OF PROJECT NOISE BASED ON TRIGGER LEVEL

Evaluation is made using the triggers level for residential and non-residential receivers found in environmental protection authority, Appendix-D.

**Table-5.2: Evaluation of Project Noise Based on Trigger Level**

No.	Sensitive Receptor	Leq,15h dB	Leq,1h dB	Evaluation
1	Residential Building-1	36	-	No impact
2	Saris Medium Clinic	-	55	No impact
3	Ethio-Indian Friendship School	-	41	No impact
4	Saint Joseph Church	-	57	Little impact
5	Nefas Silk Technic College	-	44	No impact
6	Sebstie Negasa Primary School	-	53	No impact
7	Nefas Silk Medium Clinic	-	47	No impact
8	Saint Joseph Higher Clinic	-	52	No impact
9	Nave Hotel and Tourism Institute	-	57	Little impact
10	Senay Medical Centre	-	46	No impact
11	Kety Saint Gabriel Higher Clinic	-	57	Little impact
12	Betzata Hospital	-	55	No impact
13	Residential Building-2	56	-	No impact
14	Catering and Tourism Training Institute	-	54	No impact
15	A.A Tegbareid Poly Technic College	-	56	Little impact

16	Federal Police Hospital	-	58	Little impact
17	Saint Lideta Mariyam church	-	57	Little impact
18	EIABC	-	45	No impact
19	Armed Forces Referral and Teaching Hospital	-	42	No impact
20	Saint Estifanos Church	-	54	No impact
21	Saint Ourael Church	-	45	No impact
22	Admas University College	-	47	No impact
23	Tsinu Medium Clinic	-	59	Little impact
24	Sealite Mihret Saint Mariyam Church	-	44	No impact
25	Ethiopian Civil Service University	-	56	Little impact
26	Saint Michael Church	-	38	No impact
27	Residential Buildings-3	58	-	No impact
28	Doctor Bekele Lema Clinic	-	59	Little impact
29	EL-EYOB medium Clinic	-	57	Little impact

### 5.3. COMBINED EFFECT OF PROJECT AND BACKGROUND NOISE

The combination of two or more sound pressure levels at a single location involves 'decibel addition' or the addition of logarithmic quantities. Figure 5.1 provides a handy graph that can be used to add sound levels in decibels. For example, if two sound levels of 64 dB and 60 dB are to be added, the difference in decibels between the two levels to be added is 4 dB. The curve intersects the "4" where the increment to be added to the higher level is "1.5." Therefore the sum of the two levels is 65.5 dB. Mostly, when the difference is 10 dB or more, no adjustment is necessary because the total contribution of the lower sound level will be insignificant compared to the higher sound level. <sup>[3]</sup>

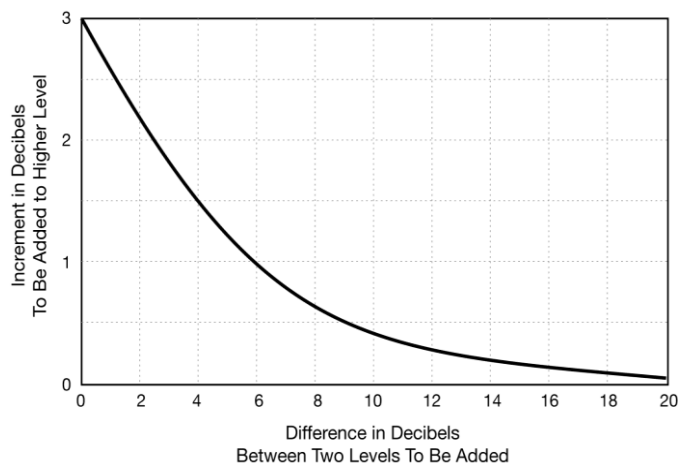

**Figure 5-1. Graph for Approximate Decibel Addition**

After this, evaluation for combined effect is made by comparing those combined noise levels with the standard levels found in Appendix-D.

**Table-5.3: Combined Effect of Project and Background Noise**

No	Sensitive Receptor	Background Noise, dB		Project Noise, dB		Difference, dB		Combined Noise, dB		Evaluation
		Leq,15h	Leq,1h	Leq,15h	Leq,1h	Leq,15h	Leq,1h	Leq,15h	Leq,1h	
1	Residential Building-1	65	-	36	-	29	-	65	-	Moderate impact
2	Saris Medium Clinic	-	70	-	55	-	15	-	70	Moderate impact
3	Ethio-Indian Friendship School	-	65	-	41	-	24	-	65	Little impact
4	Saint Joseph Church	-	65	-	57	-	8	-	66	Moderate impact
5	Nefas Silk Technic College	-	65	-	44	-	21	-	65	Little impact
6	Sebstie Negasa Primary School	-	65	-	53	-	12	-	65	Little impact
7	Nefas Silk Medium Clinic	-	70	-	47	-	23	-	70	Moderate impact
8	Saint Joseph Higher Clinic	-	70	-	52	-	18	-	70	Moderate impact
9	Nave Hotel and Tourism Institute	-	65	-	57	-	8	-	66	Little impact
10	Senay Medical Centre	-	70	-	46	-	24	-	70	Moderate impact

11	Kety Saint Gebriel Higher Clinic	-	70	-	57	-	13	-	70	Moderate impact
12	Betezata Hospital	-	70	-	55	-	15	-	70	Moderate impact
13	Residential Building-2	70	-	56	-	14	-	70	-	Moderate impact
14	Catering and Tourism Training Institute	-	65	-	54	-	11	-	65	Little impact
15	A.A Tegbareid Poly Technic College	-	70	-	56	-	14	-	70	Moderate impact
16	Federal Police Hospital	-	70	-	58	-	12	-	70	Moderate impact
17	Saint Lideta Mariyam church	-	70	-	57	-	13	-	70	Moderate impact
18	EIABC	-	65	-	45	-	20	-	65	Little impact
19	Armed Forces Referral and Teaching Hospital	-	65	-	42	-	23	-	65	Moderate impact
20	Saint Estifanos Church	-	70	-	54	-	16	-	70	Moderate impact
21	Saint Ourael Church	-	70	-	45	-	25	-	70	Moderate impact
22	Admas University College	-	65	-	47	-	18	-	65	Little impact
23	Tsinu Medium Clinic	-	65	-	59	-	6	-	66	Moderate impact
24	Sealite Mihret Saint Mariyam Church	-	65	-	44	-	21	-	65	Moderate impact
25	Ethiopian Civil Service University	-	65	-	56	-	9	-	66	Little impact
26	Saint Michael Church	-	65	-	38	-	27	-	65	Moderate impact
27	Residential Buildings-3	65	-	58	-	7	-	66	-	Moderate impact
28	Doctor Bekele Lema Clinic	-	70	-	59	-	11	-	70	Moderate impact
29	EL-EYOB medium Clinic	-	70	-	57	-	13	-	70	moderate impact

## 5.4. Discussion

As can be seen in the evaluation result the induced noise level from Addis Ababa light rail transit doesn't have a negative impact on the people living or working under each sensitive building. If there were no background noise activities like road way operation, peoples in these buildings safely carry out their work without any noise influence from AALRT.

In almost every section of the rail line the contribution of rail ways induced noise to environmental noise is insignificant. This implies that, peoples don't severely sense the noise from each pass by of the train. But, the background noise induced has a negative impact on the residence or worker living there. Due to this fact, mitigation measures has to be judged for existing structure, for future sensitive developments, the background noise impact should be considered.

Onward, Ethiopian Rail way Corporation might have a plan to upgrade the existing transport service. During this time arrangements or changes to the current condition might be applied. Here, consideration must be given to the change of noise levels induced from rail ways. Following are expectations and then limits to be checked while arrangements are to be done.

### 1. Increasing number of trains

Currently, the number of trains in a single event used in AALRT is two. But, if Ethiopian rail Way Corporation planned to increase the transportation service by increasing number of trains and keeping other conditions constant. The maximum number of train should be;

- Maximum noise level for hospital,  $L_{eq,1h}=60\text{dB}$

$$L_{eq,1h}=60\text{dB} = 10\log_{10}\left[\frac{1}{(1*60*60)}\left(8 * 10^{\frac{SEL_i}{10}}\right)\right]$$

From this,  $SEL_i = 87\text{dB}$

For instance, if hospitals or clinics are planned to be constructed around the most sensitive areas, producing higher noise level during assessment.

- $L_{eq,1h} = 59\text{dB}$

Sound exposure level,  $SEL_i = 86\text{dB}$

This sound exposure level is from two trains in a single event.

- Corrections for number of trains;

$$C_1 = 10\log_{10} 2 = +3\text{dB}$$

- Constant noise level;

$$SEL_i = 86 - 3 = 83$$

- Noise level due to number of trains for maximum limit;

$$\Delta SEL = 87 - 83 = 4\text{dB}$$

Then,

$$C_t = 10\log_{10} N = 4$$

$$N = 3 \text{ *number of trains*}$$

This implies that, if Ethiopian Rail way Corporation plans to increase number of train on a single event without affecting other conditions, the max number of trains added should be one; otherwise, noise can have a negative impact on each sensitive building.

## 2. Speed of trains/Headway/

If Ethiopian Rail way Corporation plays to improve the current transportation service by increasing the speed and keeping other factors unchanged, noise impact might be induced. For instance, ERC has a plan to increase head time to 6 minute in the future.

For this head time, total number of travelling event during day time will be;

$$N = \frac{(15*60)}{6} = 150 \text{ per day}$$

$$N = \frac{(1*60)}{6} = 10 \text{ per hour}$$

For 10 numbers of event per hour, the maximum induced noise level among these sensitive building is:

$$L_{eq,1h} = 59\text{dB}$$

In which,  $SEL_i = 86\text{dB}$

For  $N = 150$ ,

$$L_{eq,1h} = 10\log_{10} \left[ \frac{1}{(1*60*60)} (10 * 10^{\frac{86}{10}}) \right] = \mathbf{61\text{dB}}$$

This is above the maximum limit allowed for hospitals, i.e. 60dB.

During this time Ethiopian Railway Corporation (ERC) should consider the impacts. The solution can be either providing a mitigation measures like barriers, sensitive receivers if they are less important or change the purpose of the building.

## 5.5. Mitigation Measures

As explained before the current condition of the railway does not result in an impact. Due to this, there is no need to provide or design any mitigation with respect to the railway network.

Instead of this, the noise produced from the existing condition induces an impact on nearby sensitive buildings. The background noise is produced from highway operations. Provision of mitigation measures for these severe impact condition is the responsibility of a highway or structural engineers.

If Ethiopian Railway Corporation (ERC) made transport service improvement program and applies conditions explained above, the following measures can be applied from railway network perspective;

- Installation of noise barriers along the rail corridor
- Avoiding turnouts, diamond crossings and transitional speed areas near sensitive receivers
- The use of continuously welded rail rather than jointed rail
- Reducing the gradient of the track as much as possible to reduce engine and brake noise
- Avoiding level crossings near sensitive receivers to reduce disturbance from warning horns and bells

## CHAPTER SIX

### CONCLUSION AND RECOMMENDATION

#### 6.1. Conclusion

The noise induced from rail way transport service have impacts like annoyance, psychological effects, lose of hearing, nervous system, sleep lessness and damage to material. To be saved from such impacts the level of noise induced from transport operations should be determined and compared with allowable standard limits. If this level exceeds the trigger level, mitigation measures might be suggested and designed. Various noise sensitive buildings exist within 35 meter, which is the evaluation distance of Addis Ababa high rail transit. The major sensitive buildings existing there are clinics, hospitals, schools and places of worships. Noise induced from Addis Ababa light rail transit operation doesn't have a negative consequence. The levels of noise produced are below the trigger levels suggested by the standard. The ambient activities produce more noise than the rail way operations. Peoples couldn't severely sense additional noise induced by the railway network over the background noise. But, this background noise has an impact, so mitigation reallocation; repurpose solutions might be required by the concerned body.

Ethiopian Railway Corporation should check the noise levels if decisions are made for transportation improvement.

#### 6.2. Recommendation

The following points are suggested based on the assessment works;

1. New sensitive buildings can be planned and constructed near AALRT under the current conditions.
2. If future developments are required for upgrading or improving AALRT transportation facility, considerations or noise assessment must be given.
3. Keeping other conditions constant the maximum number of trains to be added to the current conditions is one. If it is planned to add more than this, solutions like mitigation measures, reallocation should be applied.
4. If ERC increases the head time to 6 minute, which is a plan of them in near future, detail assessment must be done and then solutions suggested and applied.
5. Field measuring equipment's like sound level meter should be available within our country for detail and exact assessment results.

## REFERENCES AND FURTHER READING

- [1] EPA SA 2010, *Guidelines for the assessment of noise from rail operations*, public consultation, Environment Protection Authority, South Australia.
- [2] EPA 2000, *Rail infrastructure noise guideline*, NSW Environment Protection Authority, Sydney. See also [www.epa.nsw.gov.au](http://www.epa.nsw.gov.au)
- [3] FTA 2006, *Transit noise and vibration impact assessment*, US Federal Transit Administration, Washington.
- [4] Uwe CLAUSEN, Clause DOLL and Francis James FRANKLIN 2012, 'Reducing railways Noise pollution', Piero SOAVE, Policy Department Structural and Cohesion Policies, European Parliament.
- [5] IPPC 2002, *horizontal guidance for noise, Part 2; noise assessment and control*, commission organisation, Integrated Pollution Prevention and Control, Environment Agency, Liz Greenland.
- [6] Landrum and Brown, Laguna Niguel, Fred Greve P.E, Matthew B. Jones P.E, Jose Mercado and Alexis Rodeiguez 2012, *Wilmington School and Residence Sound Attenuation Program, report prepared for Noise Measurement*, Harbor Community Benefit Foundation, San Pedro.
- [7] Felsburg Holt and Ullevig, 2008, *Traffic Noise and Vibration Impact Assessment Prepared for Federal Highway Administration, Federal Transit Administration, Colorado Department of Transportation, North I-125, EIS*.
- [8] *Railway Noise, measurement techniques and standardization*, Department of Energetic, Nuclear and Environmental Control Engineering. D.I.E.N.C.A., University of Bologna, Viale Risorgimento 2, 40123 Bologna, Italy
- [9] ISB 1995, *Calculation of railway Noise*, Department of Transportation, HSMO.
- [10] Minister of Public Works and Government Services Canada 2011, *Railway noise measurement and reporting methodology*, Canadian Transportation Agency, Canada.
- [11] C.D. Juis and A.Putra, 2011, 'On simple Technique to Measure the Airborne Noise in a Motor Vehicle using Source substitution', Universiti Teknikal Malaysia Melaka, Malaysia
- [12] IS 4954-1968, 1979, *Recommendations for Noise Abatement in town Planning*, Indian Standards Institution, India.
- [13] Edis B. Berglund, T.Lindvall, D.H.Schwela, Geneva: WHO 1999, *International Standard, World Health Organisation*.

- [14] Noise costs, 'Transportation costs and benefit analysis', victoria transport policy institute. (see also [www.vtpi.org](http://www.vtpi.org))
- [15] IS 3028-1998, 1998, Automotive vehicles: *noise emitted by moving vehicles, method of measurement*, Indian Standards Institution, India.
- [16] Gianfranco Chiocchia, Marina Clerico, Pietro Salizzoni and Massimo Marro 2010, '*Impacts assessment of a railway noise in an alpine valley*', France.
- [17] P. Fiala, G.Degrande and F. Augusztinovicz 2006, '*Numerical modelling of ground – borne noise and vibration in buildings due to surface rail traffic*', *Journal of sound and vibration*.
- [18] Reference TREN/A1/46-2005, '*Impact assessment study on rail noise abatement measures addressing the existing fleets*', Directorate General Energy and Transport. , European Commission.
- [19] Shao-Yi Hsia and Yu-Tuan Chou 2013, 'Research Article: *Traffic noise propagating from vibration of railway*', *Mathematical Problems in Engineering*, Hindawi Publishing Corporation, Hindawi.

## APPENDICES

### APPENDIX A: GLOSSARY OF TERMS

**Background Noise:**

The total noise in the environment, in the absence of the noise under investigation.

**Continuous Welded Rail:**

A number of rails welded together to form unbroken lengths of track without gaps or joints.

**Corrugated Rail:**

A rough condition of alternating ridges and grooves which develops on the rail head in service.

**Decibel:**

The standard unit of measurement for sound pressure level and vibration level. Technically, a decibel is the unit of level which denotes the ratio between two quantities that are proportional to power; the number of decibels is 10 times the logarithm of this ratio. Also written as dB.

**Descriptor:**

A quantitative metric used to identify a specific measure of sound level.

**Equivalent Noise Level:**

The equivalent (energy averaged) continuous A-weighted sound pressure level obtained over the measurement time interval. Expressed as  $L_{Aeq,T}$ , where T refers to the measurement time interval.

**Façade Level:**

Noise levels at locations 1m from the façade of a building are described by the term *Façade Levels* and are subject to higher noise levels than those in open areas (free-field conditions) due to reflection effects.

**Free Field Noise Level:**

The noise level measured at a point in space such that the effects of reflections from facades and other objects are negligible.

**Frequency Spectrum:**

Distribution of frequency components of a noise or vibration signal.

**Idle:**

The speed at which an engine runs when it is not under load.

**Illuminated Zone:**

The region which is not screened by a noise barrier but is close to the screened area and where the barrier therefore does offer some screening effect.

**Jointed Rail:**

A system of joining rails with steel members designed to unite the abutting ends of contiguous rails.

**Light Rail Transit (LRT):**

A mode of public transit with tracked vehicles in multiple units operating in mixed traffic conditions on streets as well as sections of exclusive right-of-way. Vehicles are generally powered by electricity from overhead lines

**Locomotive:**

Separate vehicle which provides motive power for the whole train.

**Metric:**

Measurement value or descriptor.

**Noise:**

Unwanted sound. Any sound, that has the potential to cause disturbance, discomfort or psychological stress to a subject exposed to it, or any sound, that could to cause actual physiological harm to a subject exposed to it, or physical damage to any structure exposed to it, is known as noise.

**Path Difference:**

The difference in the geometric path drawn between the source position and the reception point, and the path which connects the source and reception point, but which passes over the top of the noise barrier.

**Rail Head:**

The upper part of the rail.

**Rail Infrastructure:**

Infrastructure associated with the operation of a railway.

**Rail Noise:**

Any air-borne noise generated by the operations of rail vehicles as part of a light rail, passenger rail or freight rail system.

**Rolling Noise:**

This is the noise generated by moving vehicles, produced by the wheels running over the track surface. It needs to be considered for all types of railway vehicles apart from diesel locomotives operating at full power. For this types of vehicle and operation the noise from the power unit will generally be greater than the noise generated by the rolling process.

**Rolling Stock:**

Vehicle that operates on or uses from rail operations.

**Segment:**

A section of the railway such that the variation of noise within the segment is small, (i.e. less than 2 dB(A)).

**Sensitive Receiver:**

Premises that may be affected by noise from rail operations.

**Sound Exposure Level (SEL):**

The level of sound accumulated over a given time interval or event. Technically, the sound exposure level is the level of the time-integrated mean square A-weighted sound for a stated time interval or event, with a reference time of one second.

**Source Line:**

The source line relates to the notional position of the main source of noise from vehicles operating on the railway. For all vehicles other than diesel locomotives operating under full power, the source line is taken to occur at the near – side railhead of the appropriate track. For diesel locomotives on full power, the source line is elevated to 4m above the near-side railhead.

**Switch:**

A track structure used to divert rolling stock from one track to another.

**Train:**

One or more railway vehicles which are coupled together to form a single operating unit.

**Train Line**

Rail infrastructure and its associated rolling stock that operates in dedicated rail corridors for passenger and/or freight transportation which may be electrified or hauled by diesel locomotives/railcars. Normally train lines operate at higher speeds and have a higher carrying capacity than tram lines. Train lines may also be referred to as 'heavy rail' in the relevant Development Plan, or other regulatory documents.

**Tram Line**

An electrified passenger transport system which may operate in dedicated corridors or on shared roadways with other road vehicles. Tram lines may also be referred to as 'light rail' in the relevant Development Plan, or other regulatory documents.

**Truck:**

The complete assembly of parts including wheels, axles, bearings, side frames, bolster, brake rigging, springs and all associated connecting components, the function of which is to provide support, mobility and guidance to a railroad car or locomotive.

**Wagon:**

Railway vehicle used for carrying freight.

**Wheel Squeal:**

The noise produced by wheel-rail interaction, particularly on a curve where the radius of curvature is smaller than allowed by the separation of the axles in a wheel set.

## **APPENDIX B– DETERMINATION OF BASELINE OR AMBIENT NOISE LEVEL**

The procedure uses Table B, where a neighbourhood's existing noise exposure is based on proximity to nearby major roadways or railroads or on population density.

Existing noise exposure is estimated by first looking at a site's proximity to major roads and railroad lines. If these noise sources are far enough away that ambient noise is dominated by local streets and community activities, then the estimate is made based on population density. The decision of which to use is made by comparing the noise levels from each of the three categories, roadways, railroads and population density, and selecting the highest level. In case of a lightly used railroad, one train per day or less, select the population density category.

Major roadways are separated into two categories: "Interstates," or roadways with four or more lanes that allow trucks; and "Others," parkways without trucks and city streets with the equivalent of 75 or more heavy trucks per hour or 300 or more medium trucks per hour. The estimated roadway noise levels are based on data for light to moderate traffic on typical highways and parkways using FHWA highway noise prediction procedures. Where a range of distances is given, the predictions are made at the outer limit, thereby underestimating the traffic noise at the inner distance. For highway noise, distances are measured from the centerline of the near lane for roadways with two lanes, while for roadways with more than two lanes the distance is measured from the geometric mean of the roadway. This distance is computed as follows:

where  $DGM$  is the distance to the geometric mean,  $DNL$  and  $DFL$  are distances to the nearest lane and farthest lane centerlines, respectively.

For railroads, the estimated noise levels are based on an average train traffic volume of 5-10 trains per day at 30-40 mph for main line railroad corridors, and the noise levels are provided in terms of  $L_{dn}$  only. Distances are referenced to the track center line, or in the case of multiple tracks, to the center line of the rail corridor. Because of the intermittent nature of train operations, train noise will affect the  $L_{eq}$  only during certain hours of the day, and these hours may vary from day to day.

Therefore, to avoid underestimating noise impact when using the one-hour  $L_{eq}$ , it is recommended that the  $L_{eq}$  at sites near rail lines be estimated based on nearby roadways or population density unless very specific train information is available.

**Table B: Estimation of Base Line Ambient Noise Level**

Distance from Major Noise Source <sup>1</sup> (feet)			Population Density (people per sq mile)	Noise Exposure Estimates			
Interstate Highways <sup>2</sup>	Other Roadways <sup>3</sup>	Railroad Lines <sup>4</sup>		L <sub>eq</sub> Day	L <sub>eq</sub> Evening	L <sub>eq</sub> Night	L <sub>dn</sub>
10 - 50				75	70	65	75
50 - 100				70	65	60	70
100 - 200				65	60	55	65
200 - 400				60	55	50	60
400 - 800				55	50	45	55
800 and up				50	45	40	50
	10 - 50			70	65	60	70
	50 - 100			65	60	55	65
	100 - 200			60	55	50	60
	200 - 400			55	50	45	55
	400 and up			50	45	40	50
		10 - 30		--	--	--	75
		30 - 60		--	--	--	70
		60 - 120		--	--	--	65
		120 - 240		--	--	--	60
		240 - 500		--	--	--	55
		500 - 800		--	--	--	50
		800 and up		--	--	--	45
			1 - 100	35	30	25	35
			100 - 300	40	35	30	40
			300 - 1000	45	40	35	45
			1000 - 3000	50	45	40	50
			3000 - 10000	55	50	45	55
			10000 - 30000	60	55	50	60
			30000 and up	65	60	55	65

**NOTES:**

<sup>1</sup> Distances do not include shielding from intervening rows of buildings. General rule for estimating shielding attenuation in populated areas: Assume 1 row of buildings every 100 ft; -4.5 dB for the first row, -1.5 dB for every subsequent row up to a maximum of -10 dB attenuation.

<sup>2</sup> Roadways with 4 or more lanes that permit trucks, with traffic at 60 mph.

<sup>3</sup> Parkways with traffic at 55 mph, but without trucks, and city streets with the equivalent of 75 or more heavy trucks per hour and 300 or more medium trucks per hour at 30 mph.

<sup>4</sup> Main line railroad corridors typically carrying 5-10 trains per day at speeds of 30-40 mph.

## **APPENDIX C – MATHEMATICAL QUANTIFICATIONS OF RAILWAYS NOISE**

The following noise quantification procedures and methods are applied in the assessment<sup>[9]</sup>:

### **STEP-1: Identify Sensitive Receptors**

Noise sensitive developments are identified by the Noise and Air Emissions overlay in the relevant development plan for the area. Noise sensitive development proposed within the zone identified by the overlay as well as within the evaluation distances should undertake consideration of potential noise impacts against the noise criteria.

Sensitive receivers that may be impacted by noise or vibration include:

- Residential dwellings and associated private outdoor recreational areas at the ground level (if applicable)
- Nursing homes and caravan parks that accommodate existing long-term residential use
- Educational institutions
- Hospitals
- Places of worship
- Passive recreation areas, such as parks
- Active recreation areas, such as sporting fields.

It is also important to provide a reasonable level of amenity for outdoor areas associated with schools, educational institutions and hospital grounds.

Those sensitive receptors should be found within the evaluation distance i.e. 35 meter from the tram line for light rail transit.

### **STEP-2: Calculate Reference Noise Level ( $SEL_{ref}$ ) for each Train Type**

- $SEL_{ref}$  for each different types of train passing through the position of identified receptors in step-1.
- Considerations are level track, good condition and continuously welded track supported in concrete sleepers laid on ballast.
- Two stages are involved:
  - Obtain  $SEL_{ref}$  as a function of speed as follows:
$$SEL_{ref} = 31.2 + 20 \log_{10} V \text{ dB (A) (for rolling railway vehicle)}$$
  - Correct this  $SEL_{ref}$  to the type of railway vehicle using Table C-1.
    - Use maximum attainable speed

- Output =  $SEL_{ref}$  for specific train at a distance of 25m from the track.

**Table C-1: Sound Exposure Level Corrections for Individual Railway Vehicles**

Reference single vehicle  $SEL_v = \text{Baseline SEL} + \text{Correction (table C-1)}$

CATEGORY	VEHICLE DESCRIPTION	CORRECTION dB (A)
1. Tread Braked Passenger Coaches (4axles)	British Rail MKI	+14.8
	British Rail MKII	+14.8
	Gatwick Express	+16.7
	Class 421EMU	+10.8
	Class 422EMU	+10.8
	London Underground-A Stock	+12.9
	London Underground-Tube Stock	+7.1
2. Disc Braked Passenger Coaches (4axles)	British Rail MKIII	+6.0
	British Rail MKIV	+6.0
	Class 319EMU	+11.3
	Class 465EMU	+8.4
	Class 466EMU	+8.4
	Class 165DMU	+7.0
	Class 166DMU	+7.0
2.1. Disc Braked Light Rail way Passenger Coach (6axles)	Manchester Metro link LRV (articulated)	+15.8
2.2. Disc Braked Light Rail way Passenger Coach (8axles)	South Yorkshire Super tram LRV(double articulated)	+14.9
3. Tread Braked Freight Vehicles (2axles)	2axle tank wagons	+12.0
4. Tread Braked Freight Vehicles (4axles)	4axle tank wagons	+15.0
5. Disc Braked Freight Vehicles (2axles)	Merry Go Round Coal	+8.0
	Hopper HA	
6. Disc Braked Freight Vehicles (4axles)	Freightliner	+7.5
7. Locomotive (Diesel)	Class 20	+14.8
	Class 31	+16.6
	Class 33	+14.8
	Class 37	+16.6
	Class 43	+18.0
	Class 47	+16.6
	Class 56	+16.6
	Class 59	+16.6
	Class 60	+16.6
	Class 73	+14.8
	Class 86	+14.8
	Class 87	+14.8
	Class 90	+14.8
	Class 91	+14.8
8. Diesel Locomotives Under Full Power	Class 20	0.0
	Class 31	0.0
	Class 33	0.0
	Class 37	0.0
	Class 43(HST power car)	0.0
	Class 47	0.0
	Class 56	0.0
	Class 59	0.0
Class 60	0.0	

### STEP-3: Corrections

#### 1. Number of Vehicles

- Number of vehicles of appropriate type which are contained within the train.

Correction =  $10 \log_{10}(N)$  dB(A) where N is the number of vehicles comprising the train

#### 2. Source Enhancement

- Trains pass over different types of track or structures such as bridges.
- Correction factors given in Table C-2 should be used in the absence of more detailed or local information.

**Table C-2: Correction to Rolling Noise for Different Track and Track Support Structures**

Type/Description	Correction Factor dB (A)
Continuously welded Rail (CWR)	
Concrete sleeper Ballast	0
Concrete sleepers Ballast	0
Jointed track (18.3m lengths). Points and Crossings	+2.5
Slab track	+2
Concrete bridges and viaducts*	+1
Steel Bridges	+4
Box girder with rails fitted directly to girder	
+orthotropic lab. Rail bearer +cross girder +lattice girder	+9

#### 3. Gradient

- Speed already considers the gradient; therefore, no further correction is needed.

#### 4. Distance Correction

- The correction for distance is determined by using the formula given as follows:

Correction =  $-10 \log_{10}(d'/25)$  dB(A)      Valid for  $d' \geq 10\text{m}$

- This requires determination of the shortest slant distance  $d'$  separating the source position, S, from the reception point, R. (Figure C-1 below)

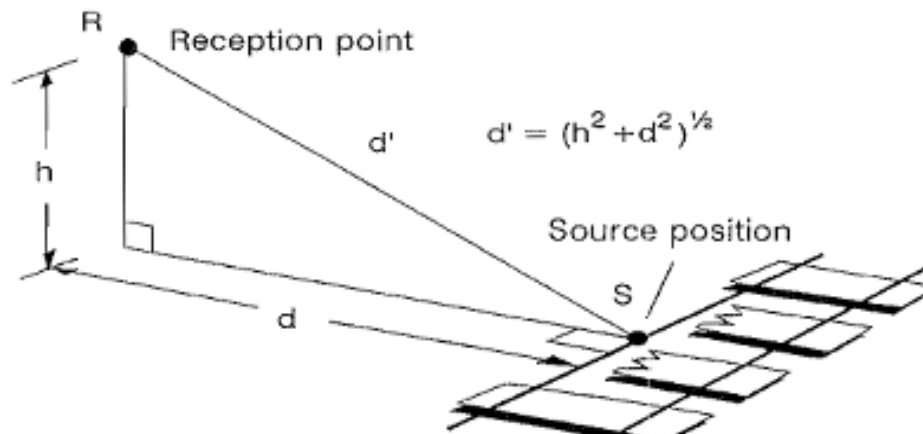
**Figure C-1: Source and Receiver Geometry for the Calculation of the Distance Correction**

### 5. Air Absorption

- The correction for air absorption is given by the equation:

$$\text{Correction} = 0.2 - 0.008 d' \text{ dB (A)}$$

### 6. Ground Absorption

- If and only if the propagation is totally unobstructed.
- If partially obstructed, this will be taken as one case for comparison.
- For conditions where the segment is not obstructed at the reception point and where propagation is over an absorbing ground surface such as grass land, cultivated fields or plantation of trees and shrubs, an additional correction for ground cover (often referred to as ground absorption) needs to be taken into account. No ground cover correction is needed when the ground is an acoustically hard, reflecting surface such as concrete or water.
- Here the way how to develop ground absorption correction is not shown because the case study is reflecting surface ground condition.

### 7. Correction for Ballast

- Because of the open structure of the ballast layer, some attenuation of noise will occur when the noise generated by the railway vehicles propagates over the ballasted tracks.

$$\text{Correction for Ballast} = -1.5 \text{ dB(A)}$$

- The correction should not be applied for the case of a single track railway, or for a locomotive on power. In addition, the correction should not be applied for any other type of track support structure, or for screened propagation.

## 8. Partially obstructed propagation

- For cases where the segment is partially screened and it is unclear whether to treat the segment as an obstructed segment or an unobstructed segment, both corrections should be applied and the lower of the two resulting noise levels taken.

## 9. Obstructed propagation

- The screening effect of intervening obstruction such as noise barriers, walls and buildings needs to be taken into account. The screening provided by hedges, bill boarding's and temporary structures should be ignored for the purpose of entitlement calculations.
- The degree of screening depends on the relative positions of the source S, the reception point R and the point B where the diffracting edge along the top of the obstruction cuts the vertical plane, i.e. normal to the track, containing both S and R.

### Potential Barrier Correction dB (A)

#### 1. *Shadow Zone*

For  $\delta > 2.5\text{m}$  Correction = -21.0 dB (A)

For  $0 < \delta < 2.5\text{M}$  Correction =  $-7.75\log_{10}(5.2 + 203\delta)$  dB (A)

#### 2. *Illuminated Zone*

For  $\delta > 0.4\text{m}$  Correction = 0

For  $0 < \delta < 0.4\text{m}$  Correction =  $0.89 + 2.14 \log_{10}(10^{-3} + \delta)$  dB (A)

- If the barrier has a reflective surface on the side facing the railway, then the correction given in the equation below should be determined and added to the barrier potential (A) obtained from the above formulas.

### Correction for Reflection

For  $D > 20\text{m}$  Correction = 0 dB (A)

For  $1\text{m} < D < 20\text{m}$  Correction =  $5 - 0.25D$  dB (A)

For  $D < 1\text{m}$  Correction = 4.8 dB (A)

*D is the horizontal distance (metres) between the barrier and the railhead*

*(NB only valid where the barrier is 1m or more above the railhead)*

- When the barrier has an acoustically absorbing surface on the railway side of the barrier then reflection correction should not be used and no further correction to the barrier potential (A) should be made. In addition the

correction for reflective barriers will not apply if the height of the barrier above the railhead is  $< 1.0\text{m}$  or if the source is a diesel locomotive on power.

**Figure C-2: Site Geometry to Evaluate the Path Difference ( $\delta$ ) for obstructed propagation**

(a) Simple barrier

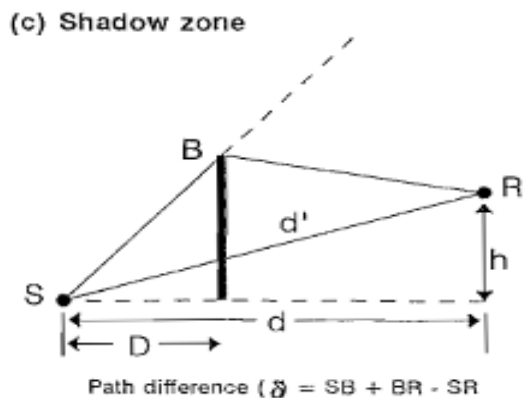
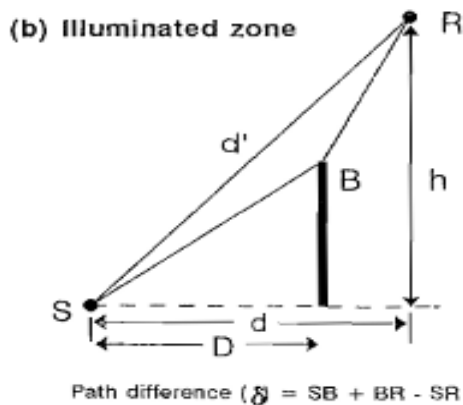
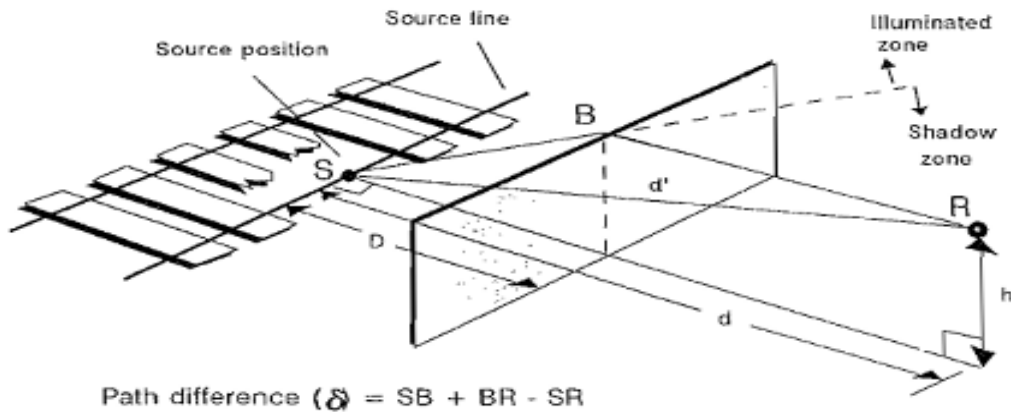

- The above procedure can be applied to thin screens, particularly those which have been purposely constructed as acoustic barriers, and walls and fences provided they have been constructed with no significant air gaps either between panels and the supporting framework or along the bottom edge of the barrier.
- The above method can also be applied to determine the screening provided by a continuous row of buildings or an embankment or cutting, although the method of determining the path difference may differ depending upon the type and geometry of the obstruction. The following paragraphs deal with different types of obstructions and to the specific procedures to adopt in

each case. (NB In all cases the potential barrier correction is to be calculated in the same vertical plane as the distance correction, i.e. normal to the track.)

## 10. Barriers

- The additional attenuation referred to earlier as ground correction, or ballast correction are ignored when calculating the effect of barriers since the sound propagating close to the ground is obstructed by the barrier. However, under certain conditions (e.g. low barriers erected on grassland), it is possible for this ground absorption effects to exceed the calculated screening provided by the barrier. Under these circumstances the noise levels with and without the barrier should be calculated and the lower of the noise levels used.
- Where more than a single barrier is interposed between the source line and the reception point then the screening provided by each barrier should be calculated separately, including any additional corrections to allow for reflecting barriers, and the lower of the two resulting noise levels used.

**Figure C-3: Evaluating the Path Difference ( $\delta$ ) for Parallel and Non Parallel Barriers**

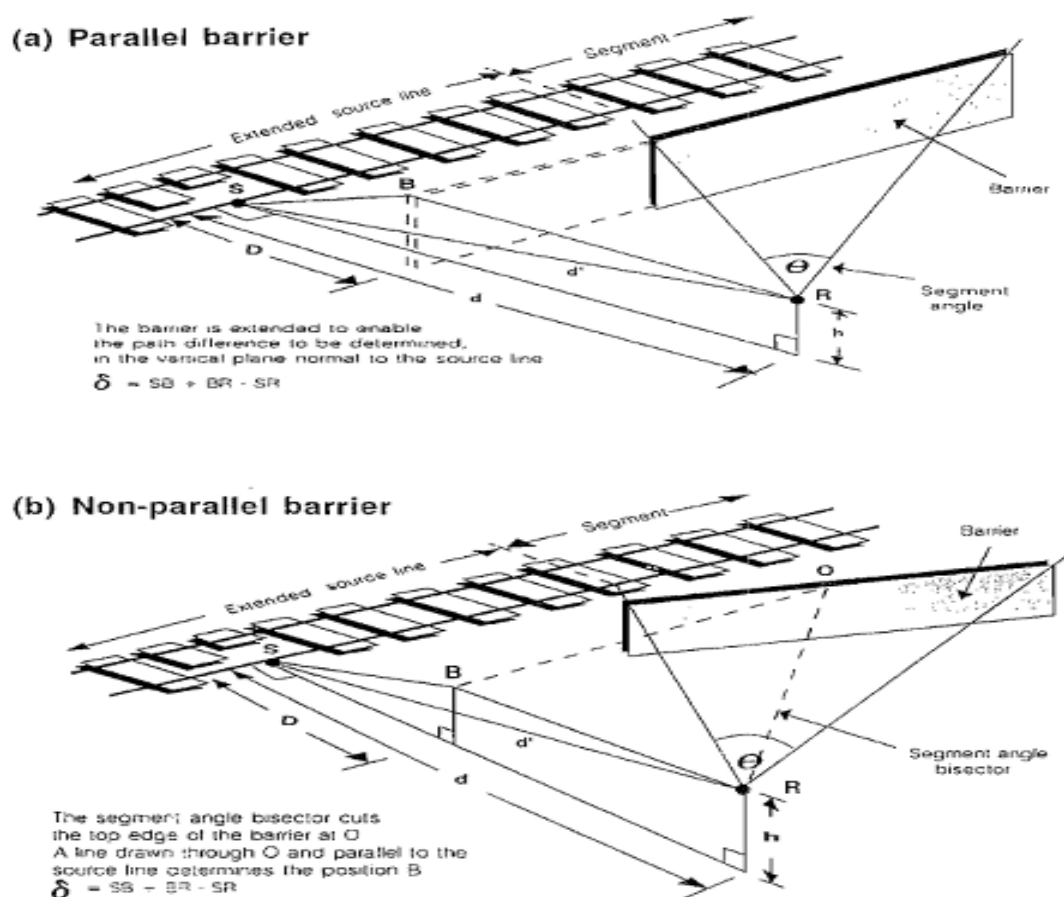

### 11. Buildings

- When considering the calculation of noise levels at locations situated behind a row of buildings located alongside a railway, considerations has to be given to whether the buildings form an effective continuous barrier or whether there are substantial gaps between individual buildings or building clusters.

**Figure C-4: Screening by Buildings**

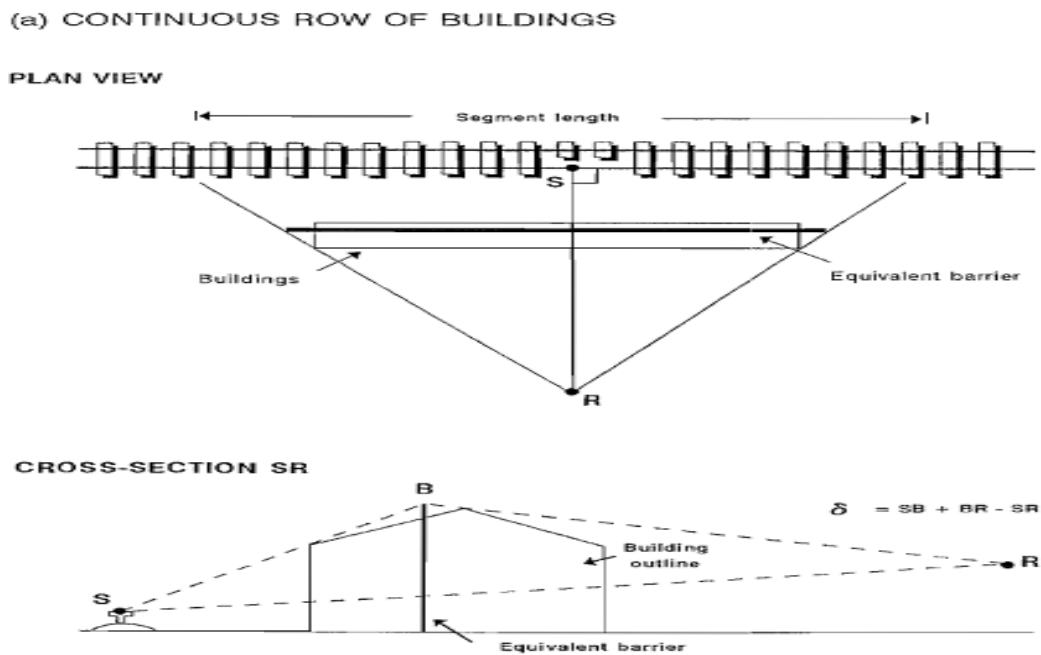

(b) SCREENING BY BUILDINGS, WITH GAPS

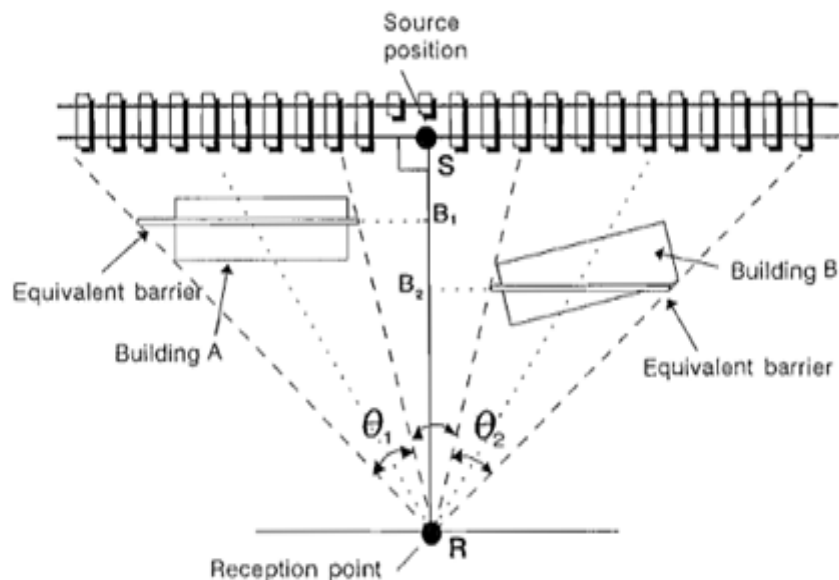

**BUILDING A**

- Is parallel to the source line; the equivalent barrier is determined along the segment bisector using the same procedure used in figure 7.5(a). The equivalent barrier is then extended parallel to the source line and the path difference,  $\delta$ , is determined in the vertical plane normal to the source line through RS, i.e.  $\delta = RB_1 + B_1S + RS$

**BUILDING B**

- Is not parallel to the source line; the equivalent barrier is determined along the bisector to the segment defined by the building. The equivalent barrier is then extending parallel to the source line as in the previous discussion and the path difference,  $\delta$ , is determined in the vertical plane normal to the source line through RS, i.e.  $\delta = RB_2 + B_2S + RS$

**12. Embankments and cuttings**

- To evaluate the potential barrier correction for a railway running on an embankment or in a cutting, the position of the equivalent barrier should be determined geometrically. Having determined the equivalent barrier, the barrier correction for absorbent barriers given by the formula in barrier discussion part should be used. In all calculations involving a correction for screening, the correction for ballasted track should not be applied.

**13. Retained cutting**

- Where the cutting has a vertical or near vertical sides (i.e.  $< 15^\circ$  slope to the vertical plane) then additional complications may arise when determining the screening correction.
- For a single screening wall the barrier potential correction is determined as before by constructing the appropriate geometry to determine the path difference. However, where the cutting consists of vertical or near vertical walls on both sides of the railway, then reflections of noise from the far-side wall of the cutting could reduce the predicted screening performance of the near-side wall. The degradation of screening performance becomes greater as the depth of the cutting increases and an approximation to this effect can be obtained by subtracting 0.5dB (A) from the potential barrier correction for each metre depth of the reflecting wall (rounded to the nearest metre.)

- For situations where the reflecting wall has a slope of more than  $15^\circ$  to the vertical or where the height of the reflecting wall is less than 1.5m above the near-side railhead then no additional correction due to reflection will be made.

**Figure C-5: Screening by Embankments and Cuttings**

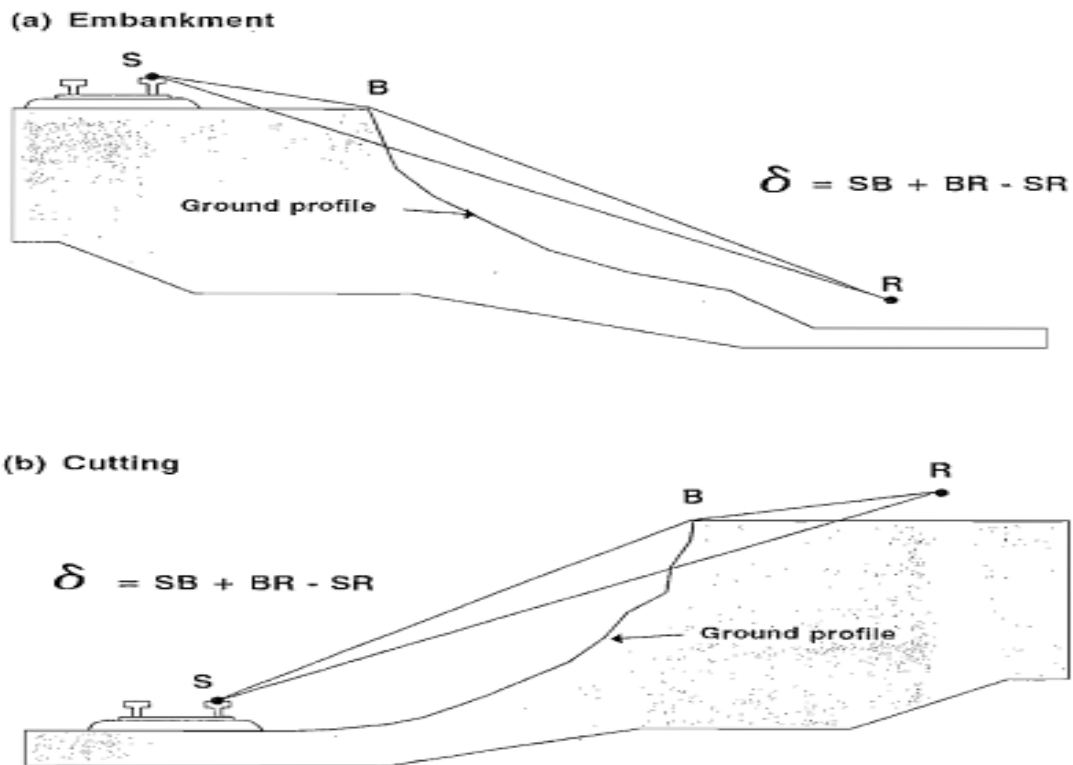

#### 14. Parallel noise barrier

- Where noise barriers exist on both side of a railway and are roughly parallel, a similar situation exists to that described in the previous discussions for a retained cutting as noise reflected from the far-side barrier can degrade the screening performance of the near-side barrier should be reduced by 0.5 dB (A) for each metre of the far-side barrier height.
- It follows that when the far-side barrier is a purpose built acoustically absorbing barrier, then no degradation in the screening performance of the near-side barrier will occur as a result of reflections from the far-side barrier. In such cases the adjustment to the potential barrier correction to account for reflections should not be applied. Similarly if the far-side barrier is not vertical and the slope is greater than  $15^\circ$ , or if the height of the far-side barrier is less than 1.5m above the near-side railhead, then the correction for reflection should also be ignored.

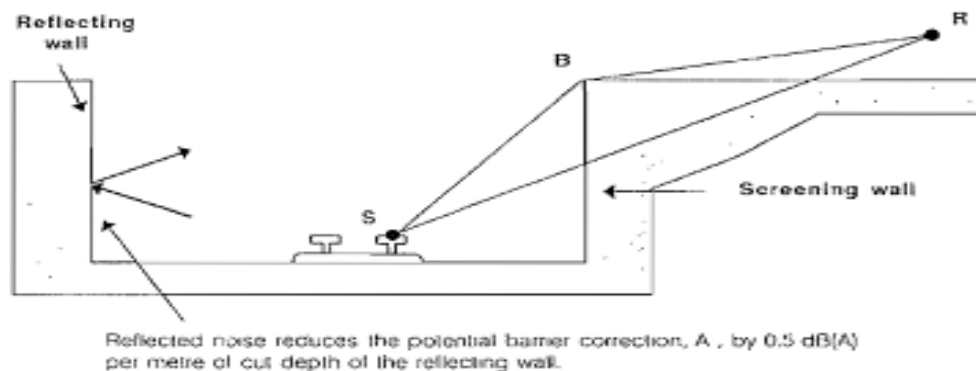
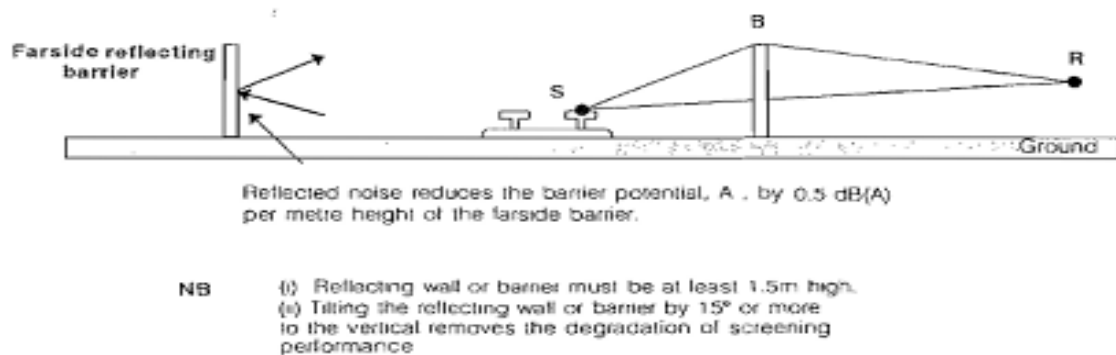
**Figure C-6: Screening by Retained Cuttings and Dual Barriers****(a) Retained cutting****(b) Dual noise barriers****15. Reflection Effects**

The free field noise level applies where the site is open and clear and the reception point is well away from other facades.

**A. Façade effect**

- For the purpose of calculating entitlement under the railway noise insulation regulations, it is necessary to calculate the noise 1 meter in front of a building façade.

**Correction for Façade Effect=+2.5dB (A)**

- However, where the building façade acts as a screen to the source line within the segment then no façade correction should be applied when calculating the contribution from that segment to the overall noise level from the railway.

**B. Reflection from opposite facades**

- Where there are houses, other substantial buildings or a noise fence or wall beyond the railway track(s) on the opposite side of the rail way and

approximately parallel to the railway, a correction for reflection from the opposite façades facing the reception point is required in addition to the façade correction given in above. The correction only applies where the height of the reflecting surface is at least 1.5 metres above the near side rail head. No correction should be applied when the opposite reflecting surface is a purpose built noise absorbing barrier.

- The correction for reflection from opposite façades is  $+1.5 (\theta'/\theta) \text{dB(A)}$ .  $\theta'$  is the sum of the angles subtended by all reflecting façades on the opposite side of the rail way facing the reception point, and  $\theta$  is the total angle subtended by the source line at the reception point (see Figure C-8).

**Figure C-7: Calculating the Reflection Correction for Facades Facing the Reception Point on the Far-Side of the Railway Traffic Stream**

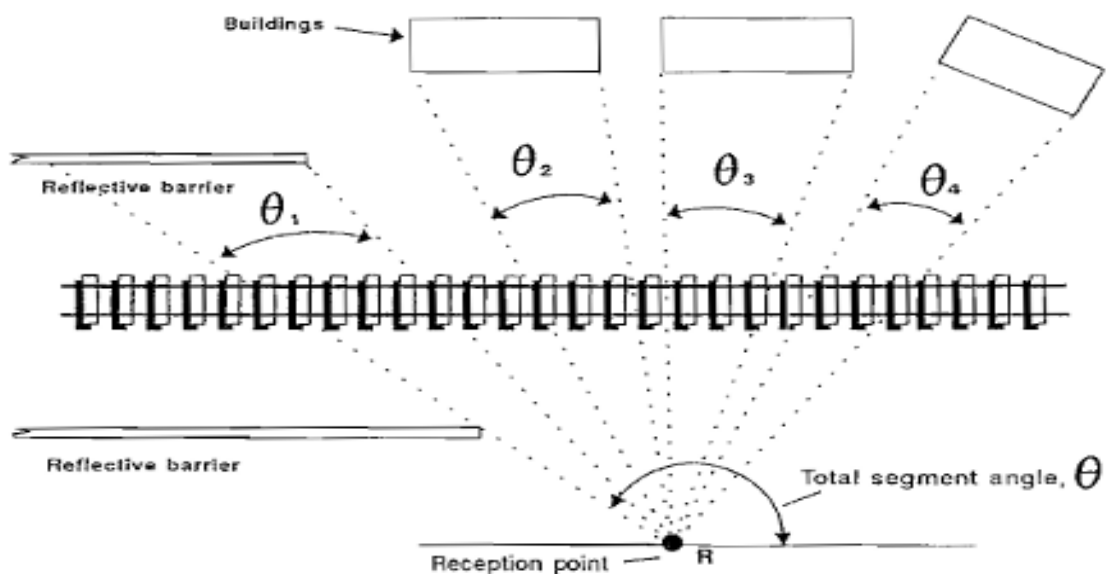

$$\text{REFLECTION CORRECTION} = + 1.5 \left( \frac{\theta'}{\theta} \right) \text{dB(A)}$$

$$\text{where } \theta' = \theta_1 + \theta_2 + \theta_3 + \theta_4$$

$$\text{and } \theta = \text{TOTAL SEGMENT ANGLE}$$

**STEP-4: OBTAIN  $L_{Aeq,T}$** 

$$\diamond L_{Aeq,T} = 10 \log_{10} \frac{1}{T} \sum_{i=1}^N \left( n_i \times 10^{\frac{SEL_i}{10}} \right)$$

$$\diamond L_{Aeq,(\text{period})} = SEL - 10 \log_{10} T$$

$$\diamond L_{DN} = \log_{10} \frac{1}{24} \left[ \left( 15 \times 10^{\frac{L_{Aeq,15h}}{10}} \right) + \left( 9 \times 10^{\frac{(10 + L_{Aeq,9h})}{10}} \right) \right]$$

Where:

- T is the total time in the relevant period in seconds (i.e. hours  $\times$  60  $\times$  60)
- n is the number of events in each type of event
- N is the number of types of events (e.g. Tangaras and coal trains would be two types of events)
- $SEL_i$  is the representative event SEL of each type of event as determined from individual measurements at the most-affected receiver, which is then summed over the different type of events occurring at the site.

## APPENDIX D – RAILWAYS NOISE CRITERIA

### Part-1: Railways Noise Trigger Levels for Light Rail

#### Environmental Protection Authority

#### Guidelines for Noise Assessment from Rail Infrastructures

#### 1. Noise Criteria for Residential Receivers<sup>[1]</sup>

These noise criteria represent external noise levels at the most exposed façade at the ground level.

**Table D-1: Noise Criteria for Residential Receivers**

Period	Noise criteria, dB(A)		
	Rail infrastructure developments		New sensitive developments near existing railway line
	New railway line	Upgraded existing railway line	
Day, 7 am to 10 pm	60 $L_{Aeq,15h}$	65 $L_{Aeq,15h}$	60 $L_{Aeq,15h}$
	80 $L_{Amax}$	85 $L_{Amax}$	80 $L_{Amax}$
Night, 10 pm to 7 am	55 $L_{Aeq,9h}$	60 $L_{Aeq,9h}$	55 $L_{Aeq,9h}$
	80 $L_{Amax}$	85 $L_{Amax}$	80 $L_{Amax}$

*Source: Environmental Protection authority, South Australia, page-8*

The criteria outlined in Table d-2 are also applicable for nursing homes, aged care facilities and for caravan parks accommodating long term residential use. If private or community outdoor recreation areas associated with the sensitive noise receiver are provided, the residential noise criteria in Table D-2 should be met in at least one of these locations to enable residents to enjoy a place of quiet amenity.

#### 2. Noise Criteria for Non-Residential Receivers

##### Case-1: External Noise Levels<sup>[1]</sup>

The noise criteria represent external  $L_{Aeq}$  noise levels at the most exposed sensitive façade for the hour of operation of the land use unless otherwise stated.

**Table D-2: External Noise criteria for non-residential sensitive receivers during hours of operation**

Landuse	Noise criteria, dB(A)		
	Rail infrastructure developments		New sensitive developments near existing railway line
	New railway line	Upgraded existing railway line	
Educational institutions	65 $L_{Aeq,1h}$	65 $L_{Aeq,1h}$	65 $L_{Aeq,1h}$
Hospitals	60 $L_{Aeq,1h}$	60 $L_{Aeq,1h}$	60 $L_{Aeq,1h}$
Places of worship	60 $L_{Aeq,1h}$	60 $L_{Aeq,1h}$	60 $L_{Aeq,1h}$
Passive recreation areas*	60 $L_{Aeq,15h}$	65 $L_{Aeq,15h}$	60 $L_{Aeq,15h}$
Active recreation areas such as sporting fields*	65 $L_{Aeq,15h}$	65 $L_{Aeq,15h}$	65 $L_{Aeq,15h}$

Source: Environmental Protection authority, south Australia, page-9

\*Level to be assessed at most affected location of the recreation area.

### Case-2: Internal Noise Levels<sup>[2]</sup>

**Table D-3: Internal rail noise trigger levels applicable to light rail developments for sensitive land uses other than residential**

Other sensitive land uses	Noise trigger levels dB(A) (when in use) <sup>1</sup>	
	New rail line development	Redevelopment of existing rail line
	Resulting rail noise levels exceed:	Development increases existing rail noise levels by 2 dB(A) or more in $L_{Aeq}$ for that period <i>and</i> resulting rail noise levels exceed:
Schools, educational institutions and child care centres	40 $L_{Aeq(1h)}$ internal	45 $L_{Aeq(1h)}$ internal
Places of worship	40 $L_{Aeq(1h)}$ internal	45 $L_{Aeq(1h)}$ internal
Hospital wards	35 $L_{Aeq(1h)}$ internal	40 $L_{Aeq(1h)}$ internal
Hospitals other uses	60 $L_{Aeq(1h)}$ external	65 $L_{Aeq(1h)}$ external
Open space – passive use (e.g. parkland, bush reserves)	60 $L_{Aeq(15h)}$ external	65 $L_{Aeq(15h)}$ external
Open space – active use (e.g. sports field, golf course)	65 $L_{Aeq(15h)}$ external	65 $L_{Aeq(15h)}$ external

Source: Rail Infrastructure Noise Guideline, page-10

## PART-2: RAILWAYS NOISE IMPACT CRITERIA

Federal Transit Administration (FTA)<sup>[3]</sup>

### Transit Noise Impact Assessment

#### 1. Basis of Noise Impact Criteria

**Figure D-1: Noise Impact Criteria for Transit Projects**

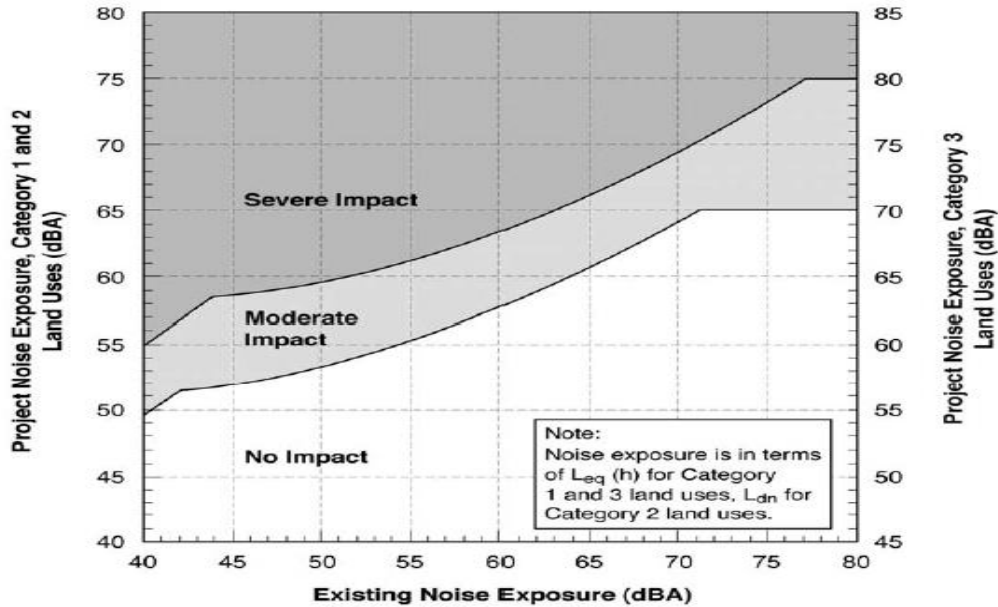

*Source: Federal Transit Administration, FTA, page-49*

#### 2. Categories and Metrics for Transit Noise

**Table D-4: Land Use Categories and Metrics for Transit Noise Impact Criteria**

Land Use Category	Noise Metric (dBA)	Description of Land Use Category
1	Outdoor $L_{eq}(h)^*$	Tracts of land where quiet is an essential element in their intended purpose. This category includes lands set aside for serenity and quiet, and such land uses as outdoor amphitheaters and concert pavilions, as well as National Historic Landmarks with significant outdoor use. Also included are recording studios and concert halls.
2	Outdoor $L_{dn}$	Residences and buildings where people normally sleep. This category includes homes, hospitals and hotels where a nighttime sensitivity to noise is assumed to be of utmost importance.
3	Outdoor $L_{eq}(h)^*$	Institutional land uses with primarily daytime and evening use. This category includes schools, libraries, theaters, and churches where it is important to avoid interference with such activities as speech, meditation and concentration on reading material. Places for meditation or study associated with cemeteries, monuments, museums, campgrounds and recreational facilities can also be considered to be in this category. Certain historical sites and parks are also included.

\*  $L_{eq}$  for the noisiest hour of transit-related activity during hours of noise sensitivity.

*Source: Source: Federal Transit Administration, FTA, page-51*