

**ADDIS ABABA UNIVERSITY**  
**ADDIS ABABA INSTITUTE OF TECHNOLOGY**  
**SCHOOL OF CIVIL & ENVIRONMENTAL ENGINEERING**



Mapping Temperature Zone of Ethiopia for Binder Performance Grading System

By

Mahlet Gahsaw Mihretu

A Thesis

Submitted in Partial Fulfillment of the Requirements for the Degree of Master of  
Science in Road and Transportation Engineering

March, 2018

Addis Ababa, Ethiopia

ADDIS ABABA UNIVERSITY  
ADDIS ABABA INSTITUTE OF TECHNOLOGY  
SCHOOL OF CIVIL AND ENVIRONMENTAL ENGINEERING

Mapping Temperature Zone of Ethiopia for Binder Performance Grading System

By

Mahlet Gahsaw Mihretu

A Thesis

Submitted in Partial Fulfillment of the Requirement for the Degree of Master of  
Science in Road and Transportation

Approved by Board of Examiner

Habtamu Melese (Ph.D , PE)

Advisor

Signature

Date

Internal Examiner

Signature

Date

External Examiner

Signature

Date

Chairman

Signature

Date

## **Declaration**

I hereby declare that research work titled “Mapping Temperature zone of Ethiopia for Binder Performance Grading System” is my original work. The work has not been presented elsewhere for assessment and award of any degree. Statements and scientific concepts, which has been used from other sources, has been properly acknowledged.

Mahlet Gashaw

## ABSTRACT

Ethiopia is located near to the equator and climatic condition varies from hot-dry-arid regions to tropical rain forest. Seasonal temperature fluctuation is very high in some parts of the country. Hence, temperature and loading time susceptible construction material such as asphalt binder should assign by considering environmental temperature range and traffic condition.

The first challenge, concerning binder-assigning process in Ethiopia, is prediction of pavement temperature. In developed countries, pavement temperature is obtained from air temperature using SHRP temperature conversion algorithm that accounts all heat-flow-balance in both fluids and solid material. In Ethiopia, it is subjected to the engineer detailed knowledge of project location and the parameters to be considered with. The second challenge is the test and specifications used by highway agencies. The current conventional method is empirical and failed to predict how the binder perform under a wide range of temperature. Therefore, the aim of this study was to provide a temperature zone map based on predicted pavement temperature and evaluate currently utilized asphalt binder by rheological test methods.

20 years' air temperature data for 27 locations are obtained from Ethiopian National Meteorological Agency to develop the temperature zone map while primary data of pen-grade 40/50, 60/70 and 80/100 binders are collected using conventional and rheological test methods. The samples are obtained from ECWC, CCCC and AACRA ongoing road project. Dynamic Shear Rheometer and Elcometer-2300 rotational viscometer is available in Addis Ababa University. The first was used to conduct Amplitude and Frequency sweep test at intermediate temperature and Performance grade determination and Multiple Stress Creep and Recovery test at highest pavement temperature; and the later was used to determine viscosity at 60°C, 135°C and 165°C.

The performance Grade temperature zone map is developed by converting 20 years' air temperature data to pavement temperature using SHRP temperature conversion model at 20mm depth of the pavement with 98% reliability. The map divided Ethiopian temperature zone into five main PG-grade counties and most of the areas are dominated by PG58-YY and PG64-YY. On the other hand, the result from rheological tests indicate that PG determination parameter  $G^*/\sin\delta$  failed to provide clear distinction between penetration graded binders and categorize both 40/50 and 60/70 as PG 64-YY. Hence, Multiple Stress Creep and Recovery test parameter, Non-recoverable Compliance ( $J_{nr}$ ), are used to provide better ranking on the performance of the binders.

Based on  $J_{nr}$  values, the samples are graded with traffic load designation beside, indicating the Equivalent Standard Axle Load it can support. Pen-grade 40/50 is designated as PG 52E-YY at 52°C, PG 58V-YY at 58°C and PG 64S-YY at 64°C.

Even though, penetration grade 40/50 have better stiffness and  $J_{nr}$  value , low-land areas such as Afar, Gambela and Benshanguil-Gumuz PG category indicate that road projects at these locations require modified binder; even for standard traffic load. Penetration grade 80/100 and 60/70 are graded as PG 58S-YY and PG 64S-YY respectively. However, pen-grade 60/70  $J_{nr}$  value at 64°C is close to the margin  $4\text{kPa}^{-1}$  , indicating the risk of using the binder for potentially developing cities and trade corridors such as Metehara and Metema.

**Keywords:** Superpave, Temperature zoning, Performance Grade

## ACKNOWLEDGMENT

My deepest gratitude goes to Dr. Habtamu Melese and AAIT highway laboratory staff for dedicating their time and energy for this research. I would also like to thank graduate students, who were working in the laboratory and assist me through the test procedure.

## Table of Contents

ABSTRACT.....	iii
ACKNOWLEDGMENT.....	v
LIST OF TABLE.....	ix
LIST OF FIGURES.....	x
ACRONYMY.....	xii
CHAPTER 1: INTRODUCTION.....	1
1.1 Background.....	1
1.2 Statement of the Problem.....	4
1.3 Objectives.....	4
1.4 Limitation of the study.....	5
1.5 Significance of the study.....	5
1.6 Organizations.....	5
CHAPTER 2: LITERATURE REVIEW.....	6
2.1 Road Distress in Ethiopia.....	6
2.2 Asphalt Performance Related Properties.....	7
2.2.1 Chemical Properties.....	8
2.2.1.1 Asphalt Binder constitute.....	9
2.2.1.2 Relationship between chemical composition and physical properties.....	9
2.2.2 Physical Properties.....	9
2.2.2.1 Stiffness.....	11
2.2.2.2 Viscosity.....	11
2.3 Conventional Test Methods.....	11
2.4 Superpave Test and Specification.....	12
2.5 Correlation of PG with Conventional Grading System.....	12
2.6 Temperature Zoning.....	14
2.6.1 Prediction of Pavement Temperature.....	14
2.6.2 Effect of Traffic Volume and Speed on Binder Selection.....	17
2.7 Chapter Summary.....	17
CHAPTER 3: METHEDOLOGY.....	19
3.1 Introductions.....	19

3.2 Sample Preparation .....	19
3.3 Asphalt Binder Tests .....	20
3.3.1 Conventional Test Methods.....	20
3.3.1.1 Penetration test.....	20
3.3.1.2 Softening Point Test.....	21
3.3.1.3 Ductility Test .....	22
3.3.1.4 Flash Point Test.....	23
3.3.1.5 Solubility Test.....	23
3.3.1.6 Rolling Thin Film Oven.....	24
3.3.2 Superpave Test Methods .....	25
3.3.2.1 Dynamic Shear Rheometer Tests.....	25
3.3.2.1.1 Amplitude Sweep Test .....	27
3.3.2.1.2 Frequency Sweep Test .....	29
3.3.2.1.3 PG Determination Test.....	30
3.3.2.1.4 Multiple stress creep and Recovery Test.....	30
3.3.2.2 Rotational Viscometer .....	31
CHAPTER 4: ANALYSIS AND INTERPRETATION.....	33
4.1 PG Temperature Zoning.....	33
4.1.1 Air Temperature Data Analysis .....	33
4.1.2 Predication of Pavement Temperature .....	34
4.1.3 Selection of Binder Grade .....	36
4.2 Analysis and Interpretation of Asphalt Test Results.....	40
4.2.1 Conventional Test Methods Result.....	40
4.2.2 Superpave Test Method Results .....	41
4.2.2.1 Amplitude Sweep Test.....	41
4.2.2.2 Frequency Sweep Test.....	43
4.2.2.3 Performance Grade Determination .....	47
4.2.2.4 Multiple Stress Creep and Recovery.....	49
4.2.2.5 Rotational Viscometer Test.....	53
4.3 Correlation of Conventional and PG Grading System.....	54
4.3.1 Correlation between Penetration and PG determination .....	54

---

4.3.2 Correlation between Softening Point and PG determination.....	56
4.3.3 Correlation between Penetration and MSCR.....	56
CHAPTER 5: CONCLUSION AND RECOMMENDATION .....	58
5.1 Conclusions .....	58
5.2 Recommendation.....	59
5.3 Future Study .....	60
REFERENCES .....	61
APPENDIX A: Amplitude Sweep Test Results .....	63
APPENDIX B: Frequency Sweep Test Results.....	65
APPENDIX C: Aging Effect on Master Curve .....	67
APPENDIX D: Aging effect on Phase Angle.....	69
APPENDIX E: Black Space Diagram .....	71
APPENDIX F: Performance Grade Test Results.....	73
APPENDIX G: MSCR-Test Results in Graph.....	75

## LIST OF TABLE

Table 1: Lot -1 RNMD's Paved Road Network Indicative Condition Findings .....	6
Table 2: Superpave equipment and purpose .....	12
Table 3: Adjusted grade bump, recommended by AASTO MP-2.....	17
Table 4: Sample asphalt and source.....	19
Table 5: High and Low Air and Pavement Temperature with PG Grading.....	37
Table 6: Sample asphalt and source.....	40
Table 7: Summarized LVR value .....	42
Table 8: PG determination test results of 80/100 (original) .....	47
Table 9: PG determination test results of 80/100 (aged) .....	48
Table 10: PG Equivalence for pen-graded asphalt .....	48
Table 11: MSCR testing temperature .....	49
Table 12: Traffic Designation AASHTO M-332.....	51
Table 13: Summary of MSCR $J_{nr}$ results .....	51
Table 14: Summary Viscosity test results.....	53
Table 15: Penetration values and $G^*/\sin\delta @ 64^\circ\text{C}$ .....	54

## LIST OF FIGURES

Figure 1: Different reliability for selecting Pavement Temperature (Asphalt-institute, 2008) .....	2
Figure 2: Asphalt cement yield influenced by crude source (NAPA) .....	8
Figure 3: Properties of bitumen during construction and subsequently in service .....	10
Figure 4: Energy balance on asphalt surface (Ksaibati, 2002) .....	15
Figure 5: Temperature zone of Pakistan .....	16
Figure 6: Pavement temperature prediction reliability .....	16
Figure 7: Penetration test setup .....	21
Figure 8: Softening point test setup .....	22
Figure 9: Ductility test setup .....	23
Figure 10: RTFO .....	24
Figure 11: Idealized response of Elastic, Viscous and Viscoelastic materials .....	25
Figure 12: Sinusoidal loading patten .....	26
Figure 13: Dynamic loading & complete cycle in DSR. (Asphalt-institute, 2003) .....	26
Figure 14: Increasing stress with time for AST .....	28
Figure 15: LVE- Range (peterson, 1999) .....	28
Figure 16: Increasing frequency with time for FST .....	29
Figure 17: Complex modulus Vs Frequency (Duruta, 2006) .....	29
Figure 18: Strain Vs Time for MSCR .....	31
Figure 19: Dynamic shear rheometer (Left) and Rotational viscometer (Right) .....	32
Figure 20: 50% & 98% reliability of maximum air temperature .....	34
Figure 21: PG grades (Asphalt-institute, 2008) .....	37
Figure 22: Performance Grade Map of Ethiopia .....	39
Figure 23: LVE-range of 60/70 E original @ 37.8°C .....	41
Figure 24: Change of LVE-range with stiffness @37°C .....	42
Figure 25: Complex modulus and Phase angle Vs. Frequency for 40/50E @37.8°C .....	43
Figure 26: Complex Modulus Master Curve (Original) .....	44
Figure 27: Complex Modulus Master Curve (RTFO aged binder) .....	44
Figure 28: Phase angle master curve (original) .....	45
Figure 29: Phase Angle Master Curve (Aged) .....	45
Figure 30: Aging effect on 40/50 E .....	46

---

Figure 31: Black Space diagram of 60/70 E .....	46
Figure 32: 80/100 pen-grade PG determination test result (Original) .....	47
Figure 33 : 80/100 pen-grade PG determination test result. (Aged).....	48
Figure 34: Temperature effect on MSCR-100 total strain for 60/70E asphalt binder .....	50
Figure 35: Temperature effect on MSCR-3200 total strain for 60/70E asphalt binder .....	50
Figure 36: Non-recoverable compliance change with Temperature.....	52
Figure 37: Effect of stiffness on total strain of 0.1kPa (58°C).....	52
Figure 38: Effect of stiffness on total strain @ 3.2kPa (58°C) .....	53
Figure 39: Penetration vs. $G^*/\sin\delta$ (linear fitting) .....	55
Figure 40: Softening point vs $G^*/\sin\delta$ @ 64 °C .....	56
Figure 41: Penetration grade Vs non-recoverable compliance ( $J_{nr}$ ) @ 3.2kPa.....	56

## ACRONYMY

AASHTO:	American Association of State Highway and Transport Officials
AACRA:	Addis Ababa City Road Administration
a.m.s.l:	Above mean sea level
AST:	Amplitude Sweep Test
b.m.s.l:	Below mean sea level
CCCC:	China Communication Construction Company
DSR:	Dynamic Shear Rheometer
ERA:	Ethiopian Road Authority
ECWC:	Ethiopian Construction Works Corporation
FHWA:	Federal Highway Administration
HMA:	Hot Mix Asphalt
LTPP:	Long Term Pavement Performance
MSCR:	Multiple Stress Creep and Recovery
NAPA:	National Asphalt Pavement Association
PAV:	Pressure Aging Vessel
PG:	Performance Grade
PR:	Percent Recovery
RTFO:	Rolling Thin Film Oven
RV:	Rotational Viscometer
SHRP:	Strategic Highway Research Program
Superpave:	Superior Performance Pavement

# CHAPTER 1: INTRODUCTION

Ethiopia, situated in the North-Easter horn of Africa, is located at  $4.05^{\circ}$  to  $14.277^{\circ}$  latitude and  $34.5^{\circ}$  to  $42.8^{\circ}$  longitude with a rugged topography of altitude range from 100m b.m.s.l to 4620 m. a.m.s.l. The North-Eastern and South-Eastern part of the country is dominated by a dry-arid climate while the North-Western and South-Western areas are elevated up to 1750m a.m.s.l and dominated by tropical rain (Engidasew, 2013).

According to 2016 Ethiopian Road Authority condition survey report, the federal road network length has reached 25,756 km out of which 11,301km is paved (flexible) pavement. Flexible pavements comprise several layers of bounded and unbounded materials. The bounded sections (usually hot mix asphalt) are a combination of properly specified and graded aggregates, asphalt cement with 3%-5% of air void. Asphalt is the glue that holds the main load bearing aggregate together and waterproofs the pavement. It influences many of the properties of flexible pavement.

Rheology is a science that deals with the flow and deformation of matter. Asphalt binder behaves as both elastic and viscous material depending on the temperature and time of applied load. Therefore, asphalt binder selection process should consider environmental temperature range of the construction site and traffic loading. The trend of predicting pavement temperature from air temperature is limited in the agencies and asphalt binder evaluations are depends on the results from conventional test method. This research divided Ethiopia temperature zone into different PG based counties.

The rheological characteristics of asphalt binder at a particular temperature are determined by both chemical composition and physical structure of the molecules in the material (John Read, 2003). Thus, the study tried to evaluate the asphalt binder's rheological properties using available equipment.

## 1.1 Background

On road construction, the uppermost layers of asphalt mixture are designed to resist the usual distress modes such as rutting (permanent deformation), shoving, fatigue and thermal crack. For most of the East-African countries, the quality and quantity of aggregates are proven to be satisfactory (Aguchi, 1984, Walle et al., 2000, A. Peccerillo et al., 2007). Asphalt binders on the other hand, are imported mainly from the Middle East countries due to its lowest price in the world

market. These asphalt types are purchased depending on the result from a conventional test method (which is empirical) and specification. Nevertheless, basic physical properties such as viscosity, stiffness and durability, should be used to grade asphalt binder. Although the tests were significant, their shortcomings force the development of new specifications, test equipment and procedures called “Superpave Performance Grade” or **PG** (Asphalt-institute, 2008).

Performance grading could be defined as “a system in which fundamental mechanical properties that are related to pavement performance are used to select binders to minimize critical failures at critical condition of pavement temperature and traffic characteristics.” (Asphalt-institute, 2008).

Highway engineers in most of the Middle-income countries attempt to point out the important aspect of PG without the need for expensive equipment. Different approaches are followed to achieve their objective starting from collecting an extensive air temperature data for a period of 18 years. Simultaneously, currently utilized asphalt were tested by both conventional and Superpave methods to determine equivalent PG from penetration graded asphalt and then evaluate the capacity to satisfy the required performance of pavement for each location.

The common minimum reliability used is 98%, meaning; for PG XX-YY binder, the maximum and minimum pavement temperature is within XX°C and YY°C respectively for 98% of the time. A higher reliability means lower risk and selection depends on road class, traffic level and binder cost and availability. Eventually, one can select suitable binder grade depending on the climatic condition of the region (M. Waseem Mirza et al., 2011).

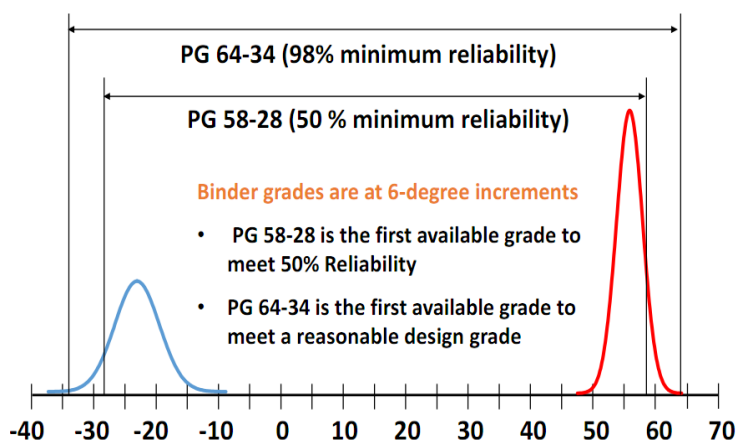

Figure 1: Different reliability for selecting Pavement Temperature (Asphalt-institute, 2008)

The implementation of Superpave techniques and specifications required a direct measurement of the performance related properties such as complex modulus ( $G^*$ ) and phase angle ( $\delta$ ). The resulted complex modulus ( $G^*$ ) is a measure of the total resistance of a material to deformation when exposed to a sinusoidal shear stress load while the phase angle ( $\delta$ ) is an indicator of the relative amounts of viscous and elastic components and quantify the lag that occurs between the applied stress and resulted strain.

In this approach, expensive and sophisticated equipment's are required, which is apparently out of reach of many pavement researchers and road laboratories at this time in Ethiopia as well as many other developing countries. The best alternative to address the lack of reliable specification is to implement the components of Superpave programs at a time.

Al-Abdul Wahhab et al. (1997) have evaluated different types of asphalt cement produced from the oil refineries in the Arabia Gulf countries and he found that the maximum pavement temperature which these types of asphalt cement sustain is  $64^\circ\text{C}$  while the temperature zoning indicated that more than 50% of the Gulf countries areas experience a maximum pavement temperature of  $76^\circ\text{C}$ .

On the other hand, comparative studies in North America, Europe, and Australia indicate that, most of the asphalt produced from locally available crude oil has a capacity to resist high temperature without modifications (Radziszewski et al., 2014). For example penetration grade 40/50 has a capacity to resist temperature as high as  $70^\circ\text{C}$ - $76^\circ\text{C}$ . This major variation between most Arabian Gulf and western asphalt binder depends on the amount and nature of the polar material due to geological formation process (Petersen et al., 1994). It is clear that there is no absolute and well-known equivalency between conventional and PG asphalt test results. Therefore, this research bases its analysis on the results obtained from the actual laboratory experiment at Addis Ababa University for the asphalt binder used by ECWC, CCCC and AACRA.

Eventually, introducing PG grading system in Ethiopia will assist and facilitate asphalt binder purchasing and selection process to meet performance criteria at expected high and low temperature extremes with a certain level of reliability. This increases pavement resistance to permanent deformation at high temperature and fatigue cracking. As a result, a cost-efficient choice of asphalt pavement will reduce taxpayer, owner, and user money.

## 1.2 Statement of the Problem

Ethiopia is a country with different climatic and geographic features; hence Pavement design manuals and selection of construction material should consider existing environmental condition. The challenge, concerning asphalt binder assigning process to a certain area, is the tests and specification used by Ethiopian Road Authority. The current conventional methods are empirical parameters and failed to predict how the asphalt binder behaves under a wide temperature range. The combination effect of temperature and rate of loading on the pavement should be represented well in testing process and specification.

Additionally, developing a relationship between air and pavement temperature is subjected to the engineer knowledge for that specific project location. Nevertheless, it is known that heat transfer through an air and through pavement is very different.

The above challenges can be checked by testing supplied asphalt binders, for different location of the country, by Superpave equipment and specifications followed by comparing it with the pavement temperature obtained from air temperature using SHRP temperature conversion algorithm (Alani et al., 2010). So far, minimum attentions has been given to address those challenges.

This research provided PG grade map based on 20 years' temperature data from Ethiopian National Meteorological Agency and the equivalent PG grade for asphalt binder using DSR rheological test equipment.

## 1.3 Objectives

The general objective of this research is to establish asphalt binder selection process on performance related parameters by considering climatic variation in Ethiopia so that problems associated with temperature effect on asphalt binders could be reduced.

The specific objectives are:

- (i) To establish PG temperature zone map based on climate data
- (ii) To evaluate the performance of currently available asphalt binders using Superpave technology

## 1.4 Limitation of the study

This research was limited to an evaluation of the asphalt binder conditioning and testing equipment available in Addis Ababa University. Lower temperature testing machines and PAV conditioning are not available. Hence, evaluated binders cannot be graded for lower and intermediate temperature.

The other limitation was the source of evaluated binders. Most of the supplier in Ethiopia import asphalt binder from United Arab Emirate. Therefore, this limits the investigation on how geological formations affect chemical composition; which in turn influences the performance difference, between asphalt binders.

## 1.5 Significance of the study

Even though the possible pavement failure sources are various, distresses due to temperature effect can be reduced using PG map of temperature zone of Ethiopia. The final product can be used to:

- Select asphalt binder for mix design by highway agencies
- Monitor asphalt purchasing procedure

## 1.6 Organizations

The research paper is organized in five chapters. The first chapter begins by introducing the basics of pavement and then elaborates about the existing problems, required methods and why it is worth to address the problems. The second chapters contain studies and experiences of researchers related to PG grading system and temperature zoning. The research experimental approach is presented in chapter three. The third chapter includes a detailed outline of the test program and methods. The analysis of both primary and secondary data and result interpretation are presented in chapter four. Conclusion, remarks, and recommendations are provided in the final chapter, chapter five.

## CHAPTER 2: LITERATURE REVIEW

The purpose of this chapter is to review researches that is related to concepts such as chemical composition, the advantage of PG, temperature conversion model and developing PG map with a certain degree of reliability so that introducing PG specification in Ethiopia will be simple.

### 2.1 Road Distress in Ethiopia

Road network is vital for the economic development of Ethiopia and the government has made bigger emphasis on improvement of the quality and size of road infrastructure in the country. In the 1990s, the government had set out a Road Sector Development Program (RSDP) to facilitate the upgrading and expansion of the road system (World-Bank, 2008). As a result, the federal road network length has increased from 13,000 km to 25, 756 km out of which 11,301km is paved while the rest 14,455 km is unpaved.

Lot-1 Road Network management directorate's road condition assessments were conducted for a total of 12,655 km of road network length out of which 6,329 km is paved. Even if the report does not relate each distress type with its cause, it summaries the status of Lot-1 pavement condition. During the condition survey, the team measured and collect pavement condition data that includes surface cracking, raveling, potholes, edge break, roughness, rutting, Texture, pavement strength data (deflection measurement ) on road pavement which could be used as an input to calculate Condition Index (CI) (HITCON-Engineering, 2016). Detail measurements on the five directorates indicate that emphasis should be given to the road length with poor and very poor category which is almost 1028 km or 18%.

Table 1: Lot -1 RNMD's Paved Road Network Indicative Condition Findings

I. No	Road Network Management Directorates	Surveyed	Average Directorate CI (%)	Condition Category	Road in Poor &V.Poor Category (km)	Road in Poor &V.Poor Category (%)	Roads Currently Under Construction
1	Alemgena	1,919.70	55.8	Fair	663.52	34.56	214
2	Adigrat	940.7	64.9	Fair	17.83	1.90	885
3	Kombolcha	1582.7	59.9	Fair	270.47	16.34	371.8

4	D/Markos	344.1	67.6	Fair	-	-	435
5	Gonder	926.4	63.5	Fair	76.25	8.23	116
Total		5,713.6	60.39	Fair	1,028.07	17.77	2,021.80

Source: Road Sector Development program

## 2.2 Asphalt Performance Related Properties

Asphalt binder is a dark-brown to black viscoelastic material that is produced by petroleum distillation (Druta, 2006). Liquid asphalt is the heaviest part of the crude oil components and obtained after highly volatile molecules leaves the distillation process such as gasoline. In the Past, penetration and viscosity grading system were the ultimate tests to measure the response of asphalt binder to load application on a limited temperature range.

The majority of pen- grade bitumens produced are used in road construction and harder grades are adopted to achieve superior performance in extreme environmental condition. Although the tests were significant, their shortcomings force the development of new specifications, test equipment and procedures called “Superpave Performance Grade” or **PG** (Asphalt-institute, 2008).

Identified limitation on conventional asphalt tests are:

1. A penetration test is an empirical test: means results do not depends on the stress-strain relationship. It requires a field experience to understand the results.
2. Penetration test measure stiffness at intermediate temperature. It does not give information on high or very low temperature.
3. Long-term aging is not represented.
4. Asphalt produced from different crudes may meet the penetration and viscosity specifications of a given gradebut perform very differently during construction and on the road lifetime.
5. Viscosity test measures the *viscous* component of an asphalt, and polymer modified cements cannot properly judge by this test.

Performance graded asphalt binders are categorized and selected to meet performance criteria at expected high and low temperature extremes with a certain level of reliability. This increase the resistance of permanent deformation (rutting) at high temperature and transverse thermal cracking at low temperature (FHWA, 1994).

The performance of asphalt in service is significantly influenced by the rheological (mechanical) properties and, to a lesser extent, the chemical constitution of the asphalt. The latter is particularly important at the road surface because the constitution of the asphalt influence the rate of oxidation and volatilization thereby, how rapidly the asphalt is eroded by traffic and environment (John Read, 2003, Bob Horan, 2003).

### 2.2.1 Chemical Properties

Rheology is a science that deals with the flow and deformation of matter. The rheological characteristics of bitumen at a particular temperature are determined by both the chemical composition and the physical arrangement of the molecules in the material. Thus, to understand changes in bitumen rheology, it is essential to understand how the structure and constitution of the bitumen. The precise composition varies according to the source of the crude oil from which the bitumen originates induced modification by semi-blowing and blowing during manufacture and aging in service (Roberts et al., 1996).

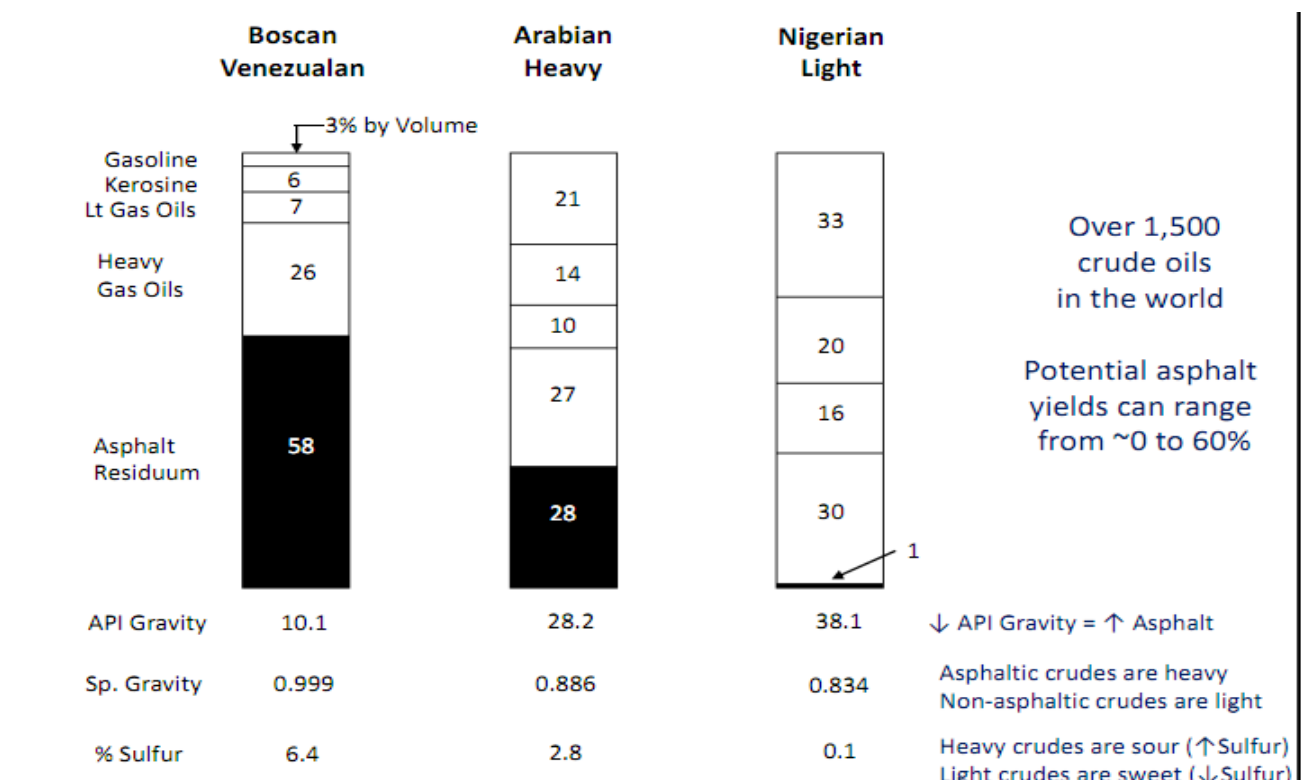

Figure 2: Asphalt cement yield influenced by crude source (NAPA)

### 2.2.1.1 Asphalt Binder constitute

It is possible to separate bitumen in to two broad chemical groups called asphaltenes and maltenes. The maltens can be further subdivided in to saturate, aromatics and resins. The asphaltene content has a larger effect on the rheological characteristics of bitumen. Increasing the asphaltene content produce harder, more viscous bitumen with a lower penetration, higher softening point. Asphaltenes can interact together through physical polar bonds which can be broken and reformed depending on application or removal of mechanical and thermal energy.

The followings are constitution of asphalt with quantitative proportion

- Asphaltene: 5-25%, insoluble black/brown amorphous solids, and highly complex polar hydrocarbon structure.
- Resins: +20%, soluble dark brown and strongly adhesive. Also, acts as a dispersing agent for asphaltenes.
- Aromatics: 40-65%, represents the major proportion of the dispersion medium for asphaltenes and is dark brown non-polar viscous liquid.
- Saturates: 5-20%, and non-polar viscous oil.

In conclusion, asphalt exhibits viscous behavior because components of the polar network can move past each other while dispersed in non-polar fluids (John Read, 2003).

### 2.2.1.2 Relationship between chemical composition and physical properties

The loss of distillates leads to preferential removal of saturates and concentration of asphaltenes. Asphaltenes content increase at high rate during construction and increase gradually with the time. Air blowing also results a considerable increase in the asphaltene content and decrease in the aromatics content. That is why the pavement became stiffer and fatigue cracks are developed in the later stage of the roadway (John Read, 2003).

## 2.2.2 Physical Properties

An understanding of the mechanism that cause asphalt pavement to fail is important if designers, contractors, and producer are employed specification, manufacturing techniques, equipment and method that will minimize the possibility of defects occurring. A viscous material is one that is semi-fluid in nature. When stressed, it will deform or tends to deform, any deformation being unrecovered when the load is removed. An elastic material also deforms or tends to deform when

stressed. However, when the loading is removed, any deformation is fully recovered. Asphalt is a visco-elastic material. The degree to which their behavior is viscous and elastic is a function of both temperature and time of loading. At high temperature or long times of loading, they behave as viscous liquid whereas at very low temperature or short time of loading they behave as elastic (brittle) solid. The intermediate range of temperature and loading times, more typical of a condition in service, results in visco-elastic behavior (John Read, 2003). The rheological requirement for asphalt during mix, compaction and in service are illustrated in figure 3.

Ideally, the materials properties used in asphalt binder specification should have a direct relationship to pavement performance. This relationship can only be accomplished through a series of complex equations which depend upon properties that describe the mechanical behavior of the asphalt binder and must be fundamental properties not empirical (Asphalt-institute, 2008).

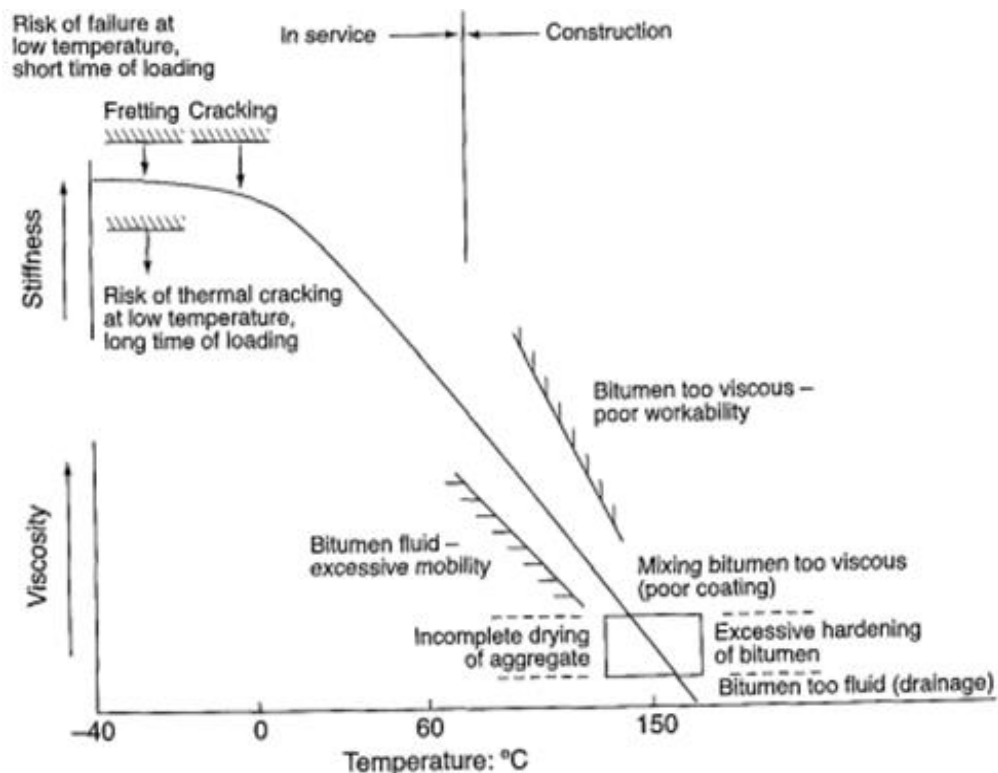

Source: shell book

Figure 3: Properties of bitumen during construction and subsequently in service

Mechanical properties are material properties that provide the relationship between load (stress) and displacement (strain). Fundamental mechanical properties used in asphalt binder specification

include viscosity, complex modulus, and stiffness. They are based on units of stress and strain and are independent of size and dimension of the test equipment (Asphalt-institute, 2008).

### 2.2.2.1 Stiffness

Asphalt stiffness divided into elastic stiffness that occurs under the condition of low temperature or short loading time; and viscous stiffness that occurs at high temperature or long loading time. The former is used to calculate the critical strain in the structure for analytic design. The latter is used to assess the resistance of the material to deformation (John Read, 2003).

### 2.2.2.2 Viscosity

Property of a fluid that tends to prevent it from flowing when subjected to an applied force. It is used to describe the flow properties of liquid.

## 2.3 Conventional Test Methods

Prior to 1987, asphalt binder was tested and graded by two primary methods: penetration grading and viscosity grading. A penetration test is purely empirical and fails to measure the consistency of the binder in fundamental scientific units. In addition, the performance of the binder during testing temperature (25°C), which is close to the average pavement service temperature, may not be applicable to lower or higher service temperature (Roberts et al., 1996).

The American Association of state and highway transport officials (AASHTO), American society for testing and materials (ASTM), Federal Highway Association (FHWA), and several state highway departments sought to replace the empirical test of penetration grading system with scientifically-based viscosity test. It measures the consistency of asphalt at the temperature approximating maximum pavement surface temperature (60°C) (Roberts et al., 1996).

Due to the drawbacks in both binder and mix specification, the US congress, in 1987, supported a five-year research program to improve the performance and durability of the roads and make those roads safer for both motorist and highway workers. Part of this research fund were used for the development of performance based asphalt specification to directly relate laboratory analysis with field performance (FHWA, 1994).

A bimodal grading system, which is based on rational performance indices, was established for both low and high pavement temperature. Thus, a precise grade may be selected to accommodate the need to control low-temperature cracking, rutting or both for a particular construction project.

In addition, it will address certain aspects of fatigue cracking (FHWA, 1994). For a given type of asphalt cement to satisfy performance criteria for a given temperature zone, it must satisfy SHRP performance tests which must be conducted at a designated temperature.

## 2.4 Superpave Test and Specification

Binder selection is driven primarily by the environmental condition at the site, i.e., the anticipated extremes in pavement service temperature. Secondary considerations are anticipated traffic volume and rate of loading (Cramer, 1999). The values of the specification criteria that warrant against distress are independent of temperature, but the values must be obtained at different temperature according to climate (Asphalt-institute, 2008). Superpave binders equipment and their purpose are listed in table 2.

Table 2: Superpave equipment and purpose

Equipment	Purpose
Dynamic Shear Rheometer (DSR)	Evaluate binder properties at intermediate and high temperature
Rotational Viscometer (RV)	Evaluate properties at high mixing temperature
Bending Beam Rheometer (BBR) Direct Tension Test (DTT)	Evaluate properties at low temperature
Rolling Thin Film Oven (RTFO)	Simulate short-term aging
Pressure Aging Vessel (PAV)	Simulate long-term aging

Source: (Zaniewski and Pumphrey, 2004)

The AASHTO M 320 table 1 specification properties needed to determine the PG specification temperature including  $G^*/\sin\delta$  (DSR) for the unaged binder and RTFO residue,  $G^*\sin\delta$  (DSR) for PAV residue, and stiffness (S) and m-value (BBR) for PAV residue. A lower limit for  $G^*/\sin\delta$  for both original and aged 1kPa and 2.2 kPa was selected to ensure that the binder has adequate stiffness to resist traffic induced stress that causes rutting in the upper pavement layers.

## 2.5 Correlation of PG with Conventional Grading System

In many developing countries the performance grading system (PG) is not yet implemented to evaluate the currently used asphalt binder for paving work. It appears that not only the unavailability of test equipment is resulting in this delay but also the lack of clear understanding

of what steps could be taken to incorporate this system. However, researchers are trying to develop a link between conventional grading system and PG (Alani et al., 2010).

In Jordan locally produced pen-grade 60-70 was tested (Asi, 2007). He found that asphalt with this penetration grade has equivalent performance grade PG64-16. He also developed a temperature-zoning map for Jordan. It consists of three grade zones, PG64-10, PG64-16, and PG70-10.

Commonly used grades in Pakistan are A-60/70 and K-60/70. The corresponding grades are PG58-22 and PG64-22, which is likely rut in areas requiring PG70-10. This may be one of the major reasons for premature failures especially rutting in most of the pavements (M. Waseem Mirza et al., 2011)

Penetration grade 40/50 and 60/70 were tested by both conventional test methods and Superpave methods to determine the equivalent performance grade in Iraq. The Superpave result indicates that 40-50 penetration grades have performance grade equivalency with PG70-16 while penetration grade 60/70 is equivalent to PG64-16 (Alani et al., 2010).

Al-Abdul Wahhab et al. (1997) have evaluated different types of asphalt cement produced from the oil refineries in the Arabia Gulf countries. They found that the maximum pavement temperature which these types of asphalt cement sustain is 64°C while the temperature zoning indicated that more than 50% of the Gulf countries areas experience a maximum pavement temperature of 76°C. Therefore, the researchers suggest modifying the asphalt in order to meet performance requirement in arid areas.

On the contrary, comparative studies in North America, Europe and Australia indicate that, most of the asphalt produced from locally available crude oil has a capacity to resist high temperature without modifications (Radziszewski et al., 2014). For example, penetration grade 40/50 has a capacity to resist high temperature as high as 70°C-76°C.

In order to know which location requires what type of asphalt, temperature zoning is an obligation. Additionally, assessment can be performed by comparing used asphalt binders for constructed roadways with the PG temperature zone and find out which road network is expected to fail at least due to improper asphalt binder utilization.

## 2.6 Temperature Zoning

The first step in implementation of Superpave methodology is establishing high and low pavement temperature for a location. The temperature defines the required performance grade (PG) of asphalt binder. The temperature zoning is carried out by using temperature data obtained from meteorology weather stations. The SHRP or LTPP-bind prediction model can be used to predict pavement temperature (Prowell, 1999).

### 2.6.1 Prediction of Pavement Temperature

Thermal environmental condition, to which pavement continuously are exposed in construction and repair phases, as well as in use, determine the temperature profile in asphaltic section. Fluctuation in ambient air temperature, intensity of solar radiation, pavement material and geometry, convective surface condition and precipitation significantly impact pavement stability and long term success of pavement design (Ksaibati, 2002, A. Ongel, 2004).

Accurate prediction of the temperature profile in pavement greatly aids pavement engineers in the assessment of pavement deflection, in back-calculation of pavement modulus values. However, implementation of Superpave raises question with respect to pavement temperature estimation since the new performance grading method for asphalt binder appears to modify the asphalt operational temperature range, and thus further limits availability of asphalt that meets the prescribed criteria. Many methods dealing with the prediction of temperature gradients in pavements are based on statistical and probabilistic methods developed based on weather and pavement data collected through the Long-term pavement Performace Program (LTPP) under SHRP. It uses the Energy-Balance concept. The primary modes of heat transfer are incident solar radiation, thermal and long wave radiation between the pavement and the sky, convection due to heat transfer between the pavement surface and the fluid (air or water) that is in contact with the surface and coduction inside the pavement as shown in figure 4 (Ksaibati, 2002). Superpave defines high pavement design temperature at a depth 20mm below the pavement surface and the low pavement design temperature at the pavement surface (Huber, 1994).

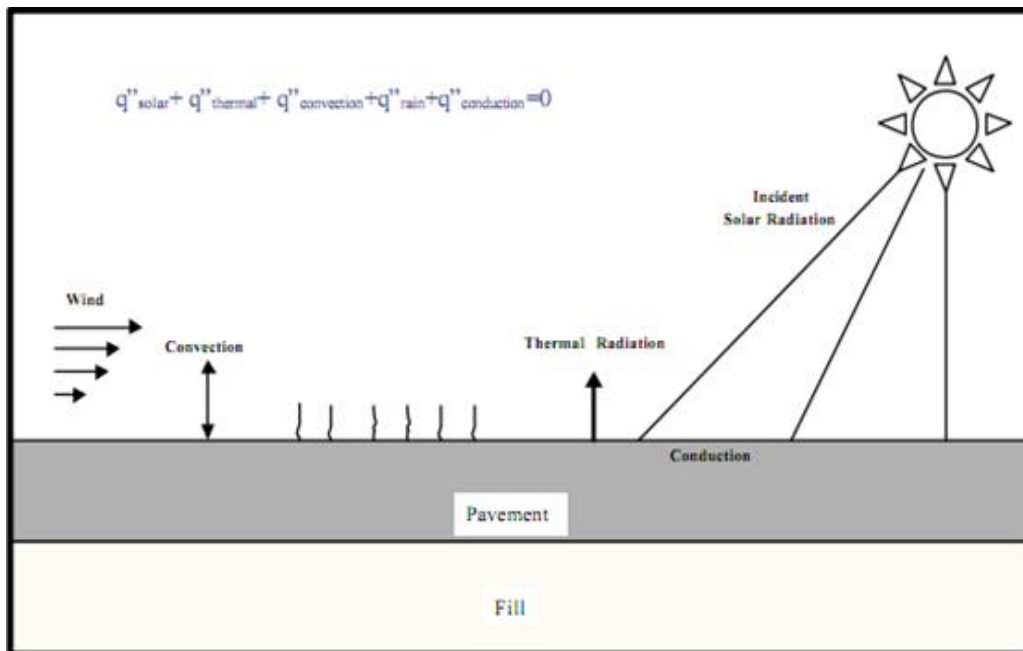

Figure 4: Energy balance on asphalt surface (Ksaibati, 2002)

Using theoretical analysis of actual conditions performed with models for net heat flow and energy balance, and assuming typical values for solar absorption (0.9), radiation transmission through air (0.81), atmospheric radiation(0.7) and wind speed (4.5 m/sec) (Huber, 1994). This equation was developed for the:

$$T_{pav,h} = (t_{air} - 0.00618Lat^2 + 0.2289Lat + 42.4)(0.9545) - 17.78 + z\sigma_{air}$$

Where:  $T_{pav,h}$  = high AC pavement Temperature at 20mm from the surface

Lat = latitude of the section

$\sigma_{air}$  = standard deviation of the 7-day max. air temperature

$z$  = standard normal distribution table,  $z=2.055$  for 98%

The low pavement design temperature at the pavement surface is defined as the one-day minimum low air temperature (Huber, 1994).

$$T_{pav,l} = T_{air} + 0.051xd - 0.000063x d^2 - z.\sigma_{air}$$

In order to know which location requires what type of asphalt, temperature zoning is an obligation. Additionally, assessment can be performed by comparing used asphalt binders for constructed roadways with the PG temperature zone and find out which road network is expected to fail at least due to improper asphalt binder utilization. A sample of mapped zone is shown in figure 5.

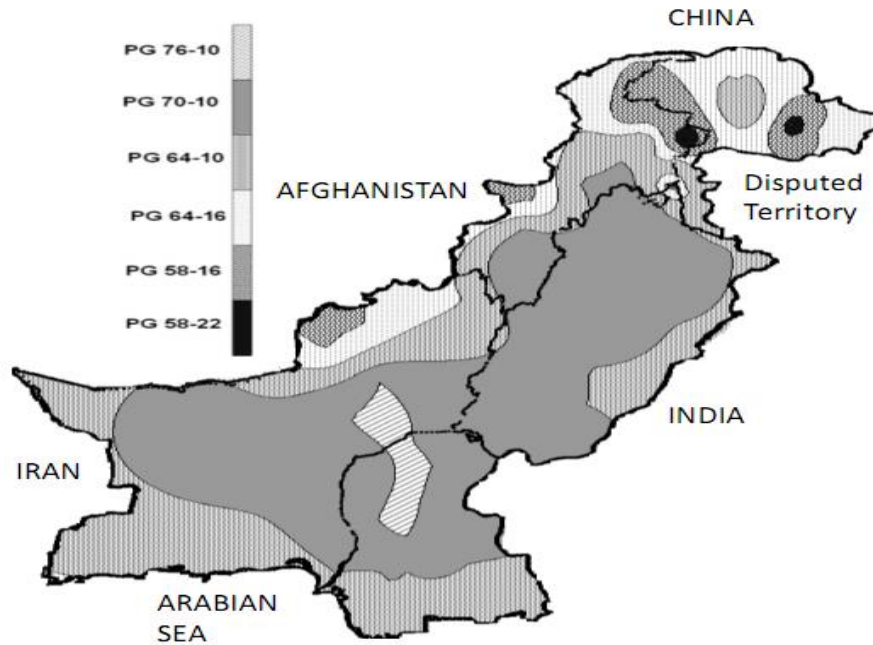

Source: M.W. Mirza, 2011

Figure 5: Temperature zone of Pakistan

The Superpave system allows the designer to use reliability measurement to assign a degree of design risk to the high and low pavement temperature used in selecting the binder grade. Superpave binder selection is very flexible in that a different level of reliability can be assigned to high and low temperature grades. Consider summer air temperature for one city which has mean seven-day maximum of  $36^{\circ}\text{C}$  and a standard deviation of  $2^{\circ}\text{C}$ . In an average year there is a 50% chance the seven-day maximum air temperature will exceed  $36^{\circ}\text{C}$ . However, only a 2% chance exist that the temperature will exceed  $40^{\circ}\text{C}$ ; hence, a design air temperature of  $40^{\circ}\text{C}$  will provide 98% reliability (FHWA, 1994).

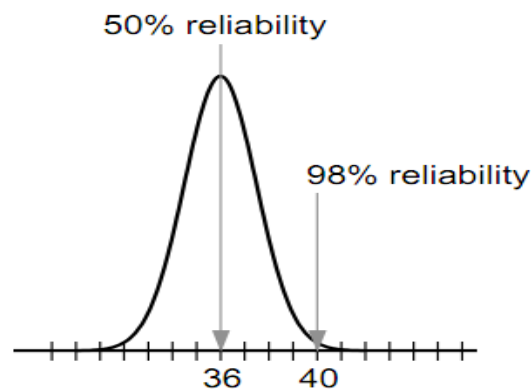

Figure 6: Pavement temperature prediction reliability

## 2.6.2 Effect of Traffic Volume and Speed on Binder Selection

The Superpave binder selection procedure described is the basic procedure for typical highway traffic condition. Under this condition, it is assumed that the pavement is subjected to a design number of fast, transient loads. For the high temperature design situation, controlled by specified properties relating to permanent deformation, the traffic speed has additional effect on performance. The AASHTO MP1 specifications includes an additional shift in the selected high temperature binder grade for slow and standing traffic situations. Also, a shift is included for the extra ordinary high number of heavy traffic loads (FHWA, 1994).

Table 3: Adjusted grade bump, recommended by AASTO MP-2

Design ESALs	Adjusted to Binder PG Grade		
	Traffic Load Rate		
	Standing	Slow	Standard
<.3	-	-	-
0.3 to <3	2	1	-
3 to <10	2	1	-
10 to <30	2	1	-
>30	2	1	1

## 2.7 Chapter Summary

The PG system is a definite improvement over the previous asphalt binder grading systems. Engineering principles are used to relate measured physical properties to field performance . A complete range of temperatures is now is considered. A constant criterion is used for all PG grades, with the temperature at which the asphalt properties changing in consideration of the asphalt grade for climate, traffic loadings, and speed.

The performance of asphalt in service is significantly influenced by the rheological (mechanical) properties and chemical constitution of the asphalt. The latter is particularly important at the road surface because the constitution of the asphalt influence the rate of oxidation and volatilization thereby, how rapidly the asphalt is eroded by traffic and environment. Due to elevation and latitude difference, temperature varies from one place to another. Since asphalt is temperature susceptible material, one should limit its use in Temperature County.

Binder selection is driven primarily by the environmental condition at the site, i.e., the anticipated extremes in pavement service temperature. Secondary considerations are anticipated traffic volume and rate of loading. Thermal environmental condition, to which pavement continuously are exposed in construction and repair phases, as well as in use, determine the temperature profile in asphaltic section. For the high temperature design situation, controlled by specified properties relating to permanent deformation, the traffic speed has additional effect on performance.

## CHAPTER 3: METHODOLOGY

### 3.1 Introductions

The two main objective of this research are (I) developing PG map and (II) assess currently available asphalt by Superpave equipment's. Each objective requires different types of approach. The first requires collecting secondary data from National Meteorological Agency and the latter require conducting laboratory test evaluation. Developing PG map is more of analytical procedure using Excel or Matlab, whichever is convenient for the researcher. This research uses matlab software to develop a template, which analyze the data obtained from the agency and the effort will be discussed in the analysis and interpretation section.

This chapter cover every test approaches, equipment and conditioning machines used to investigate asphalt's both fundamental and empirical mechanical properties. Fundamental mechanical properties are assessed using MARVEL BOHILN Dynamic Shear Rheometer and Elcometer-2300 Rotational Viscometer. At the end of this chapter, one can be used to answer the approaches required for the following questions:

1. How do we select the asphalt binder that suit our projects?
2. The asphalt binder that gives the best performance?

### 3.2 Sample Preparation

The research idea of assessment is focuses on the asphalt binders used in Ethiopia, roads constructed mainly by Ethiopian Construction Works Corporation and other contractors. Five samples were collected and three of them were from ECWC. The other two were from China Communication Construction Company (CCCC) and Addis Ababa City Road Authority.

Table 4: Sample asphalt and source

Penetration grade	Source
Pen-grade 80/100	ECWC (Bale/Arisi road project)
Pen-grade 60/70	1. ECWC (Metahara road project) 2. AACRA
Pen-grade 40/50	1. ECWC(Awash-Mille overlay) 2. CCCC (Addis-Adama Expressway)

### 3.3 Asphalt Binder Tests

Performing a test in order to evaluate how the asphalt behaves throughout the pavement life time based on chemical properties would give a more detailed and clear understanding. But a specification based on chemical properties will be very expensive and it requires complicated mathematical formulas and most of all its time consuming (J. C. Petersen et al., 1994). This is due to the variation of chemical composition between every refinery. Therefore, the purchasing as well as controlling specifications on construction site is based on asphalt physical (mechanical) properties.

Mechanical properties might be fundamental or empirical. Fundamental mechanical properties are defined in fundamental units and is independent of the dimension of the test device or tested specimen. It is used in asphalt binder specification including viscosity, complex modulus and stiffness (Asphalt-institute, 2008).

Empirical mechanical properties are based on observation and experiment rather than using fundamental properties. These properties typically depend on size of test specimen and test equipment.

This research used both empirical and fundamental mechanical properties to assess collected asphalt samples though conventional and rheological testing method respectively.

#### 3.3.1 Conventional Test Methods

Conventional tests were conducted using available equipment's in the university. Except capillary tube viscometer. Each sample is first checked using penetration test then followed by softening point, ductility and mass change. The tests were again conducted for RTFO residue. AASHTO and ASTM testing and specification was used to proceed the experimental work.

##### 3.3.1.1 Penetration test

The penetration test is one of the oldest, empirical tests for measuring the consistency of an asphalt binder. The result is recorded as the distance in tenths of millimeter that a standard needle vertically penetrates a sample of the material under known condition of loading, loading time and temperature. All collected penetration grade samples are checked using a digital penetrometer in AAIT, highway laboratory.

To conduct the penetration test, asphalt binder sample is heated to an appropriate temperature and poured in to a test container of 40mm deep penetration tin. After 1 hour cooling on environmental atmospheric temperature, the sample is brought to the standard test temperature of  $25^{\circ}\text{C} \pm 0.1$  in a temperature controlled water bath. The sample container is then placed in the penetrometer equipment. A needle of 2.5g weight is attached to the penetrometer and suspended directly over the asphalt binder sample. A 50-gram weight is attached to the needle's loading platform so that the total weight used for loading is 100 grams (50g weight and 50g needle holder). The penetrometer is lowered until the needle tip contacts the surface of the asphalt binder. The load is then released, allowing the weighted needle to penetrate the asphalt binder for 5 seconds. The distance that the needle penetrates in to the asphalt binder is reported as the penetration value. Two samples with each three measurements are collected and reported the average.



Figure 7: Penetration test setup

### 3.3.1.2 Softening Point Test

The softening point test is used to measure and specify the temperature at which asphalt binders begin to show fluidity. The softening point is also useful in evaluating the uniformity of shipments or source of supply. The softening point is an indicative of the tendency of the material to flow at elevated temperature encountered in service.

Asphalt binder is heated and poured to 2-rings. The sample is allowed to cool at atmospheric air temperature for at least 30 minute. Then assembling the ring-holder, rings, thermometer and balls are conducted at  $5^{\circ}\text{C}$  water and allowed to equilibrate for 15 minute. A steel ball of 3.5g is palced on a sample of binder contained in a brass ring which is suspended in a water. Remind that water

is used for softening point of 80°C and below. Immediately transfer the container onto the heating unit. The bath temperature is raised at 5°C per minute, the binder gradually softens and eventually deforms slowly as the ball falls through the ring. The moment the asphalt and steel ball touches a base plate 25mm below the ring, the temperature of the water is recorded. Average temperature of the two rings are reported.



Figure 8: Softening point test setup

### 3.3.1.3 Ductility Test

The ductility test is used to describe the ductile and tensile behavior of asphalt binders. The test, which is normally performed at ambient temperature, is believed to reflect the homogeneity of the binder and its ability to flow.

The test procedure is performed by first creating a standard mold shape and cover the side walls by lubricant. A heated sample of asphalt binder is then poured in to the mold and allowed to cool in air temperature followed by conditioning in a water bath at 25°C. Hot spatula are used to level the asphalt surface with the mold and again the sample is inserted in the ductility water bath and allow to condition itself for 90 minutes. After removing side walls of the mold, the specimen is loaded in the ductility machine and one end of the specimen is pulled away from the other at 5 cm/min until the thread of asphalt connecting the two parts of sample breaks. The elongation, expressed in centimeters, at which the thread of material break is designated as the ductility of the asphalt.



Figure 9: Ductility test setup

#### 3.3.1.4 Flash Point Test

As a petroleum product, an asphalt binder will release combustible fumes when heated to sufficiently high temperature. The flashing point is an indication of the temperature at which a heated asphalt binder sample will instantaneously flash in the presence of an open flame. This temperature is usually well below the temperature at which the material will support combustion which is fire point.

The most common test for flash point is Cleveland Open Cup. A brass cup is filled with asphalt binder and is heated at constant rate. A small flame is passed over the surface of the asphalt at timed intervals. When the flame passing over the sample surface causes an instantaneous flash, the temperature is recorded as the material flash point.

#### 3.3.1.5 Solubility Test

The solubility test is a measure of purity of the asphalt binder. The portion of the asphalt binder that is soluble in trichloroethylene represents the active cementing constituents. Inert component, such as salt, free carbon are insoluble.

Determining the solubility of an asphalt involves expensive and dangerous chemical such as carbon disulfide ( $CS_2$ ) and trichloroethylene. The laboratory uses 100 mm trichloroethylene as a solvent and dissolve about 2 g of asphalt binder then filter the solution using a filter paper. The amount of material retained on the filter paper is measured by sensitive weighting balance and expressed as a percentage of the original sample weight.

### 3.3.1.6 Rolling Thin Film Oven

This aging procedure was developed to subject an asphalt binder sample to a hardened condition that approximately simulates the condition that occurs in normal, hot mix facility operation. To address the issue of volatilization, the procedure incorporates a mass change determination. The change in mass is calculated based on the weight of the sample before and after aging.

The RTFO procedure is performed by pouring 35 g of heated asphalt binder into a glass bottle. If a mass change is required, the bottle is first measured, then measured with the original asphalt binder. After aging, the sample is measured for the third time and the result is reported as a percentage (%).

$$\text{Mass change} = \left[ \frac{(\text{Mass after aging}) - (\text{Mass before aging})}{\text{Mass before aging}} \right] * 100$$

To start the test, the sample bottles are placed in a vertically rotating carriage in an oven operating at 163°C and an air pipe is connected with a compressor. The bottle carriage rotates at 15 rpm for a total time of 85 minutes. During rotation, a jet of air flow at the rate of 4 l/min blows into each bottle as it passes the bottom position in the carriage. After 85 minutes, any sample bottles being used for determining mass change are cooled to room temperature before the final weight is determined. The remaining bottles are then poured and scraped into a single sample container for additional testing.

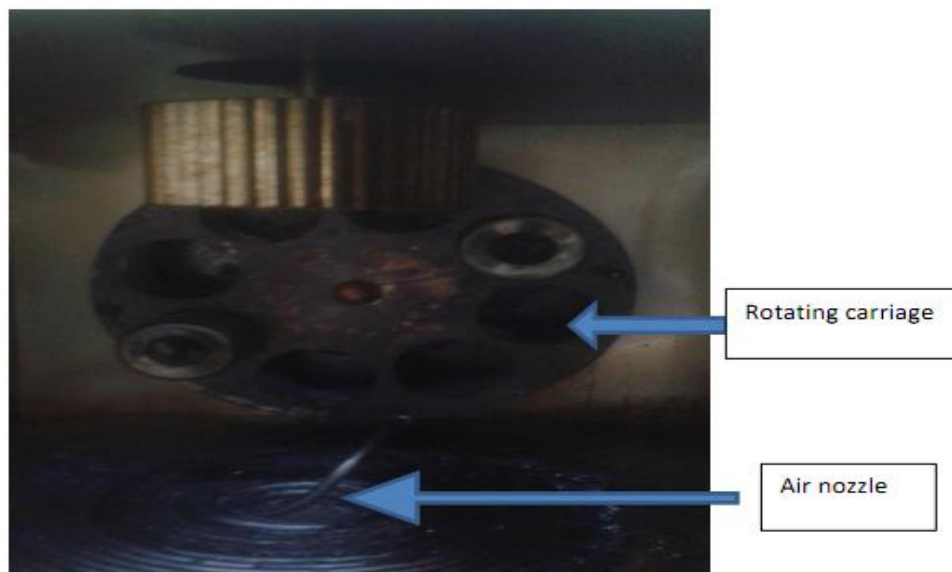

Figure 10: RTFO

### 3.3.2 Superpave Test Methods

At intermediate temperature, asphalt binder exhibit the characteristics of both viscous liquid and elastic solid. When heated, asphalt act as a lubricant, allowing the aggregates to be mixed, coated, and tightly compacted to form a smooth, dense surface. After cooling, the asphalt acts as the glue to hold the aggregate together in a solid matrix. In this finished state, the behavior of the asphalt is viscoelastic, meaning it has both elastic and viscous characteristics, depending on the temperature and rate of loading. “Spring-dashpot” model can be used to show the the response of asphalt to load. Spring represent the immediate elastic response and dashpot symbolize the slower (viscous) reaction particularly in warmer temperature (Asphalt-institute, 2003).

Superpave PG testes provide fundamental material properties in terms of moduli based upon the measurement of stress and strain. Dynamic Shear Rheometer (DSR) and Rotational viscometer (RV) are available in Addis Ababa Universty.

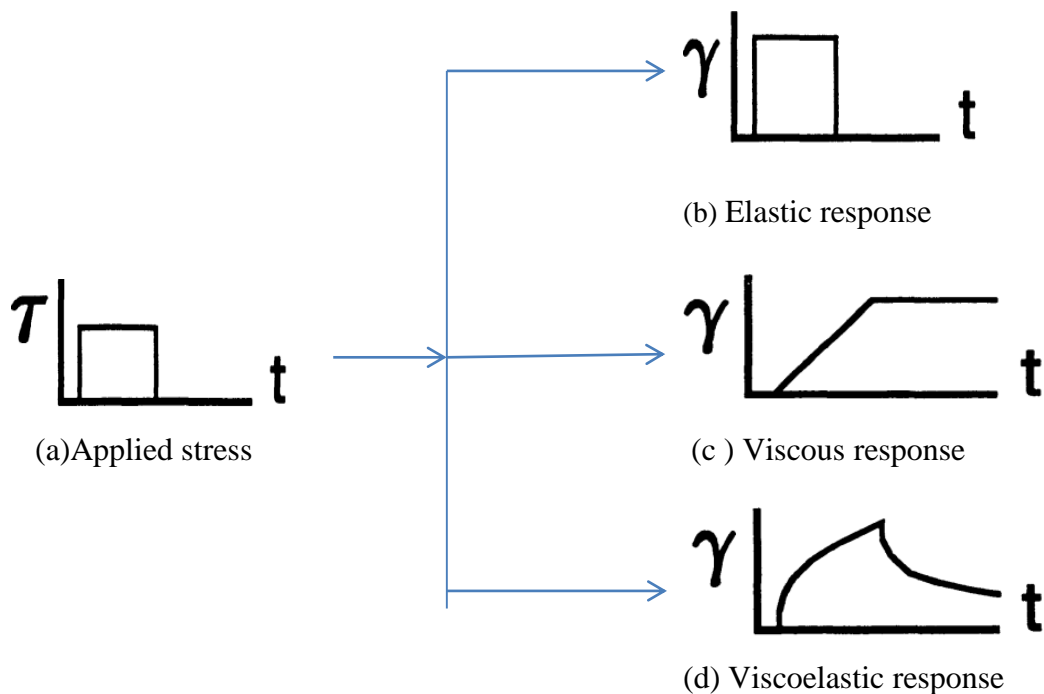

Figure 11: Idealized response of Elastic, Viscous and Viscoelastic materials

#### 3.3.2.1 Dynamic Shear Rheometer Tests

This test method provides a means for measuring the complex shear modulus and phase angle at temperature range from 3°C to 88°C, different strain and stress. To resist rutting the binder needs to be stiff and elastic; to resist fatigue cracking, it need to be flexible and elastic. The balace between these two is a critical one (J. C. Petersen et al., 1994).

The test procedure is valid for asphalt binders within the linear viscoelastic range. The 8-mm plate is used for temperatures ranging from 4°C to 40°C and the 25-mm plate is used for temperatures ranging from 46°C to 86°C. The temperature of the test specimen must be maintained at  $\pm 0.1^\circ\text{C}$  (J. C. Petersen et al., 1994). This study's experiments are conducted using a controlled-stress instrument called Bohlin CS. It applies a sinusoidally varying stress and measures the magnitude and phase of the resulting strain (Asphalt-institute, 2003).

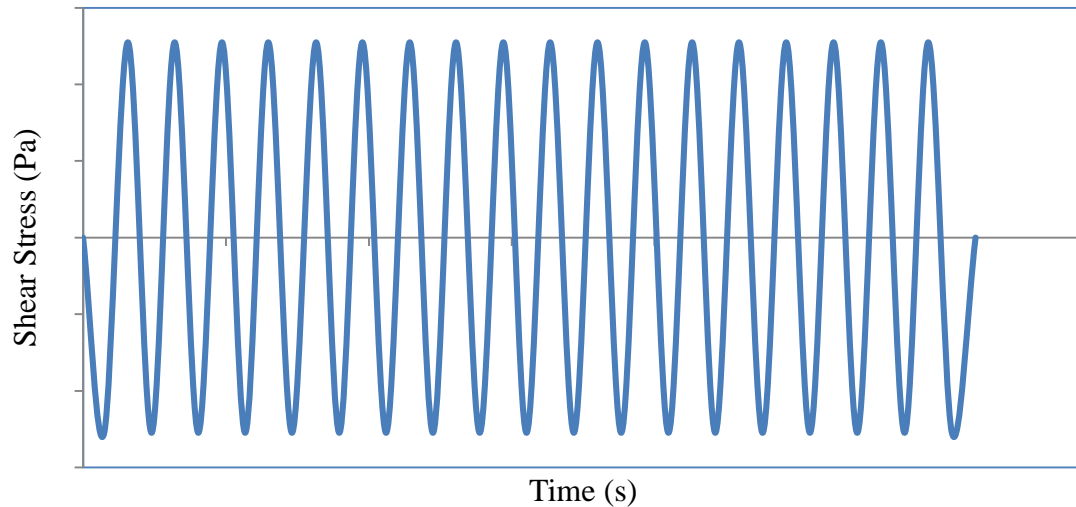

Figure 12: Sinusoidal loading pattern

The operation of a DSR uses basic concepts. A sample of asphalt binder is “sandwiched” between two parallel plates, one that is fixed and one that oscillates. Then DSR software records the specimen's response to the sinusoidal stress and calculates and displays various parameters of asphalt, such as  $G^*$ , dynamic viscosity ( $\eta^*$ ),  $\delta$ , accumulated strain, etc. DSR loading cycles are shown in Figure 13 (Asphalt-Institute, 2007).

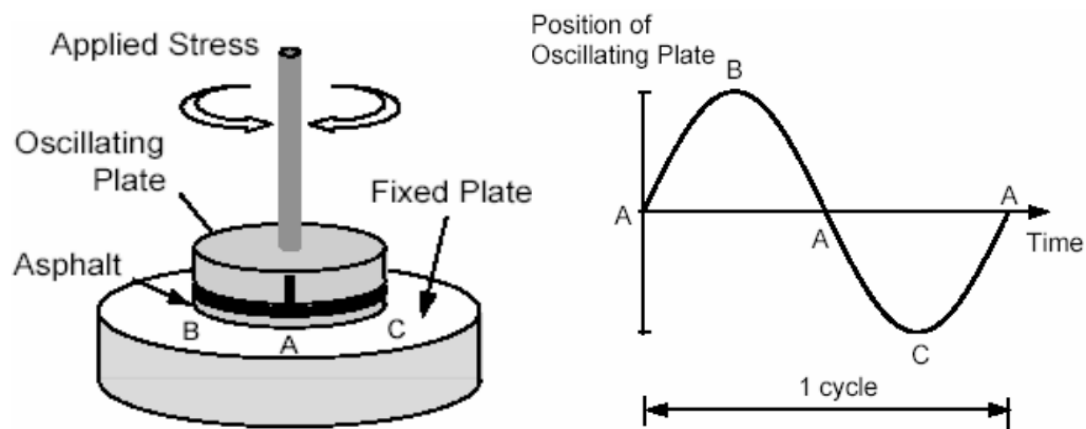
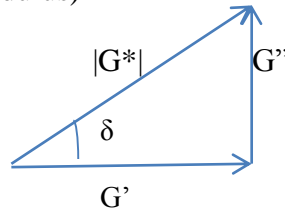

Figure 13: Dynamic loading & complete cycle in DSR. (Asphalt-institute, 2003)

At intermediate temperature asphalt behaves as viscoelastic material and the relative magnitude for elastic and viscous modulus are expressed using trigonometric equations.

$$G'' = G^* \sin \delta \dots\dots (\text{loss modulus})$$

$$G' = G^* \cos \delta \dots\dots (\text{storage modulus})$$



**Note:** elastic and viscous modulus are used interchangeably with storage and loss modulus regardless the conceptual difference.

The rheological properties were measured by conducted three main types of tests: Amplitude Sweep Test at the single frequency, Frequency Sweep Test and Multiple stress Creep Recovery Test while Performance Grade Test is conducted to determine the maximum temperature at which the asphalt binder fulfill AASHTO M-320 specification. Each tests are performed using three specimens and the average of those specimen are reported.

### 3.3.2.1.1 Amplitude Sweep Test

The test measures the Linear Viscoelastic Range of asphalt binder. The amplitude of a shear stress is varied while the frequency kept constant at 1.59 Hz until the sample flow and breaks down and rheological material functions are not independent of the set parameter anymore (Petersen et al., 1994). The tests were conducted at 21.1°C, 37.8°C and 54.4°C in order to calculate the strain which is used as an input parameter for frequency sweep test using 8-mm plates and 2-mm gap. The default 10% - 12% strain are taken as an input strain for PG determination of a neat asphalt binder.

Prior to mounting the asphalt binder specimen between the plates, the “zero gap” setting must be established at the test temperature because the frame and fixtures in the DSR change dimension with temperature. So for every 12°C temperature variation on the test, zero gap was maintained.

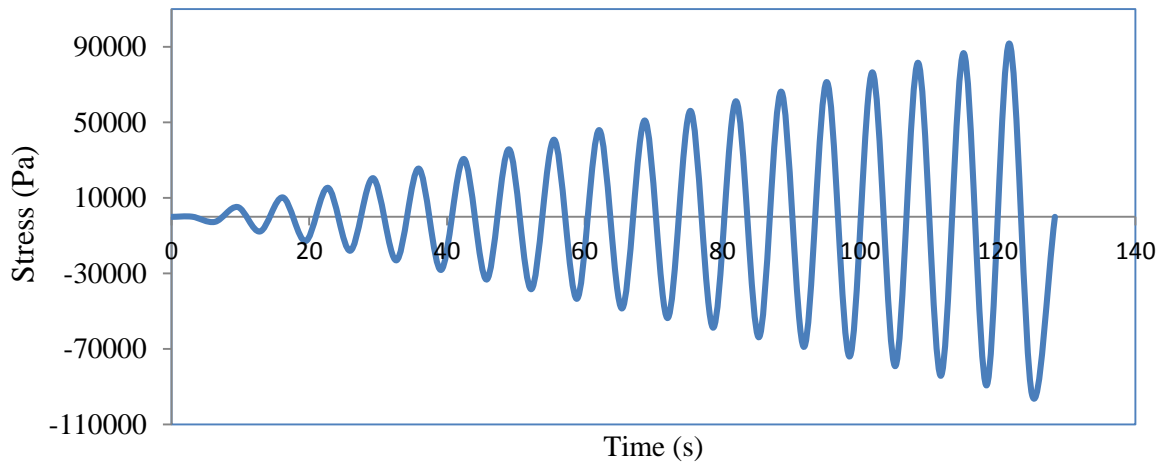

Figure 14: Increasing stress with time for AST

The specimen preparation procedure requires that the asphalt binder be heated until it is sufficiently fluid. Even if there are ways to place the specimen into the plates, Softening point ring's are used as a mold due to the lack of silicon mold. After cooling by air temperature, the specimen is correctly placed in the DSR, the test temperature are waited to be stable for ten minutes in order to equilibrate the specimen and test temperature. A controlled-stress of 0.1 kPa to 9.947 kPa is applied representing traffic loading. The final result present a graph complex modulus ( $G$ ) against shear strain ( $\gamma$ ).

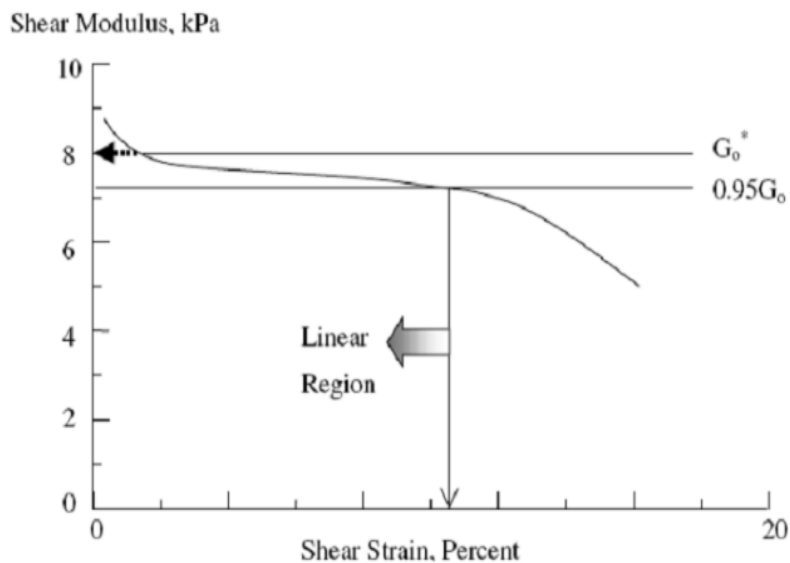

Figure 15: LVE- Range (peterson, 1999)

### 3.3.2.1.2 Frequency Sweep Test

This test method relates the assigned angular velocity of frequency to resulting oscillating stress or strain and it means that the stress or strain frequency applied is stepwise increased and for each frequency step the two resulting values of  $G^*$  and  $\delta$  are measured (Schramm, 2000).

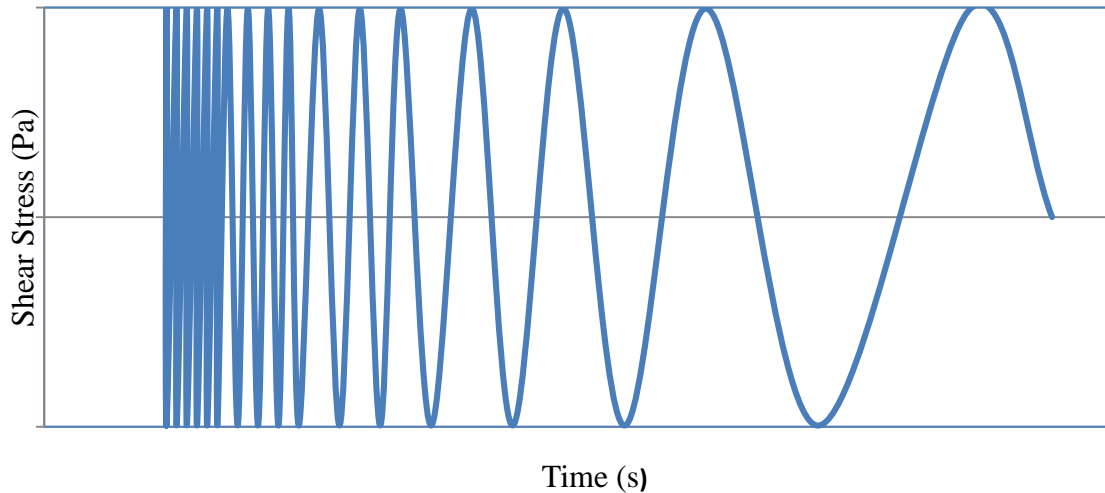

Figure 16: Increasing frequency with time for FST

In this study, FST were performed for all types of binder at 21.1°C, 37.8°C and 54.4°C with a frequency range of 0.1 Hz to 25 Hz. The resulted complex modulus ( $G^*$ ) Vs frequency, shows the behavior of asphalt binder for short term and long term relaxation time.

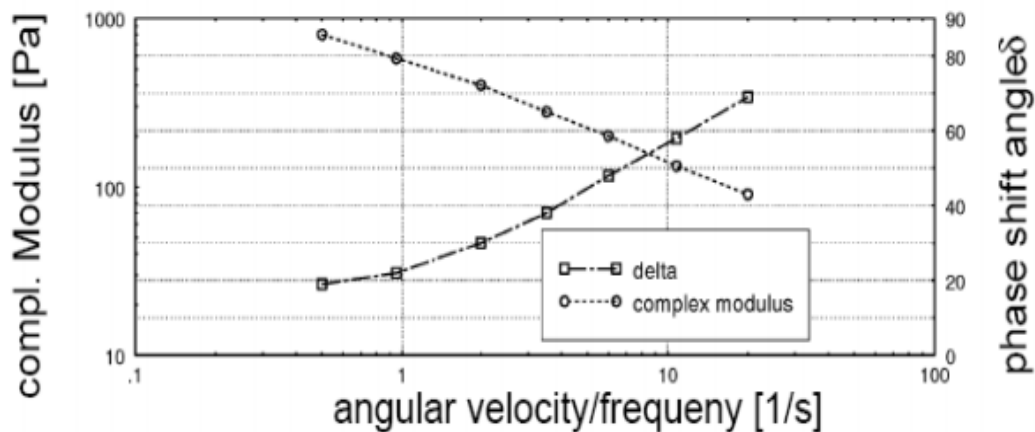

Figure 17: Complex modulus Vs Frequency (Duruta, 2006)

Frequency sweep test results are used to construct “master curves” which are able to estimate the rheological properties of the asphalt binder at any temperature and frequency.

### 3.3.2.1.3 PG Determination Test

This test is conducted at high temperature to categorize the tested asphalt binder sample into a 6°C incremental performance grading system. A constant frequency 10 rad/sec is used; representing 80 km/hr to 100km/hr speed on the highways. It was believed that the permanent deformation parameter  $G^*/\sin\delta$  is a good indication for rutting on the pavement. But studies shows that there is poor relationship between  $G^*/\sin\delta$  and rutting depth (Anderson, 2011). therefore, in this research  $G^*/\sin\delta$  is only used for checking asphalt binder environmental temperature resistance.

To conduct this test, the DSR equipment is first initailzed to operate with proper parallel plate geometry and gap. The plate is 25-mm and the gap is 1-mm. After conditioning the specimen for 10 minute the test begin with 10rad/sec frquency and 10% (aged binder) or 12% (original binder) strain as an input. The temperature is adjusted manually or authomaticall as the asphalt binder sepcimen passes the first setted temperature.

### 3.3.2.1.4 Multile stress creep and Recovery Test

The multiple stress Creep and Recovery test is the latest improvement on Superpave Performance Graded (PG) Asphalt Binder specifications. This new test and specification provide the user with a new high temperature binder specification that more accurately indicates the rutting performance of the binder and is blind to modification (Kabir, 2013).

MSCR is conducted after PG determination test because it relate rutting depth with both the environmental temperature and traffic loading (Mehta et al., 2013). Sample preparation and the paltes are the same as PG test but it require a little software adjustment.

The loading condition begins with a conditioning stress equal to 100 Pa for 10 cycles. And additional 100 Pa and 3200 Pa are applied for 1-second and allow the sample to recover for 9 seconds. Generally, in MSCR test a constant stress is assigned and the time-related strain is measured and it is called shear compliance  $J(t)$ . It defines how complian the specimen is: the higher the compliance the easier the sample can be deformed (Druta, 2006, Dolzycki, 2014). The resulted graph are shown in figure 18.

$$J(t) = \gamma(t) / \tau [1/\text{Pa}]$$

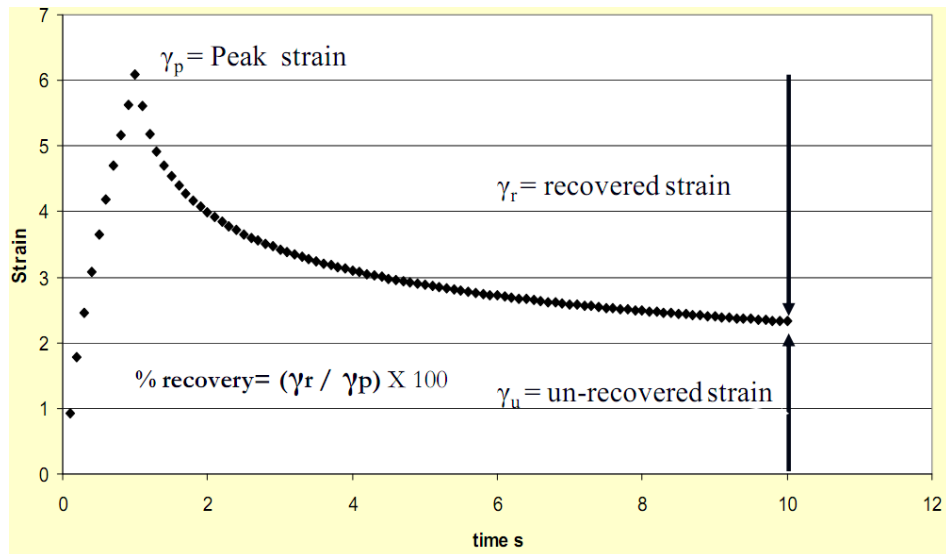

Figure 18: Strain Vs Time for MSCR

### 3.3.2.2 Rotational Viscometer

A rotational viscometer test is used to determine the flow characteristics of the asphalt binder at high temperature to provide some assurance that it can be pumped and handled at the hot-mixing facility. Rotational viscometer have larger clearances between the component, allowing for better applicability to both modified and unmodified asphalt (Asphalt-Institute, 2007).

On rotational viscometer, viscosity is determined by measuring the torque required to maintain a constant rotational speed of a cylindrical spindle that is submerged in the asphalt binder sample at a constant temperature. The torque is directly related to the asphalt binder viscosity, which is calculated automatically by the viscometer (Asphalt-Institute, 2007).

Elcometer-2300 rotational viscometer is used and the test procedure begin by preheating asphalt binder by boiled water or oil depending on the temperature which the test is conducted. The amount of binder weight depends on the spindle size. For apparent viscosity at 60°C the liquid used to heat the binder is water.

The fluid asphalt binder sample is then placed under the rotational viscometer and insert the spindle and start the rotation. The equipment displays all the required parameters on the screen and viscosity readings are done on the necessary temperatures. For dynamic viscosity at 135°C and 165°C, oil bath is used to heat the binders. Heating oil greater than 158°C was difficult therefore, approximate reading was taken to construct viscosity-temperature chart.



Figure 19: Dynamic shear rheometer (Left) and Rotational viscometer (Right)

## CHAPTER 4: ANALYSIS AND INTERPRETATION

The purpose of this section is to provide an analysis and summary on collected primary and secondary data. The test results are useful to draw correlation and conclusion between conventional and SHRP grading system. The chapter will be divided into two main parts: (I) Analysis of temperature data and (II) analysis and interpretation of experimental data.

### 4.1 PG Temperature Zoning

The first step in the introduction of Superpave technology is to determine high and low pavement temperature for a location. The temperature range of a location indicates the required performance grade of asphalt binder. This study gathered and documented air temperature data, which is the initial ground work toward establishing high and low geographical temperature zones. The division of temperature zone of Ethiopia was conducted by using temperature data obtained from 27 meteorological weather stations. The SHRP temperature prediction models were used to convert air temperature to pavement. Detail steps, for developing the temperature zones, will be discussed next.

#### 4.1.1 Air Temperature Data Analysis

The air temperature data from the Ethiopian Meteorological Agency used in this research covers 20 years of data (1995-2015) for 27 weather stations. The data represents dominant climate regions in Ethiopia. At each year, the hottest consecutive seven-days are identified by using matlab software and the average maximum air temperature for this seven-day period was calculated. After determining each year maximum temperature, a mean and standard deviation for 20 years' maximum temperature are obtained.

The syntaxes used for this study are the basics in the matlab software. "For loop" function is developed to screen out the necessary results and present it with new spreadsheet. Excel sheet can be used as an alternative analytical tool but unless visual basic is used, the process will be laborious.

The Superpave system allows the designer to use reliability measurement to assign a degree of design risk to the high and low pavement temperature used in selecting the binder grade and the standard deviations are used to decide which percentage of reliability would be assigned on

predicting pavement temperature. The assigned reliability will assure that the actual temperature will not exceed the design temperatures (FHWA, 1994).

Assignment of reliabilities depend on traffic volume, cost of binder and functional class of the road. For example: Addis Ababa has an average high temperature of  $27.7^{\circ}\text{C}$  with a standard deviation of  $0.71^{\circ}\text{C}$ . In order to decide which percent of reliability is appropriate, traffic volume and environmental temperature increment are considered. If 50% reliability (meaning  $27.7^{\circ}\text{C} + 0 \cdot 0.71^{\circ}\text{C}$ ) are chosen, there is 50% chance the seven-day maximum air temperature will exceed  $27.7^{\circ}\text{C}$ . However, with the harsh climate change and high traffic volume, 98% reliability (meaning  $27.7^{\circ}\text{C} + 2 \cdot 0.71^{\circ}\text{C}$ ) are chosen. Similarly, the one-day minimum air temperature of each year was identified and the mean and standard deviation are calculated. The calculated mean and standard deviation for 27 stations are presented in table 5.

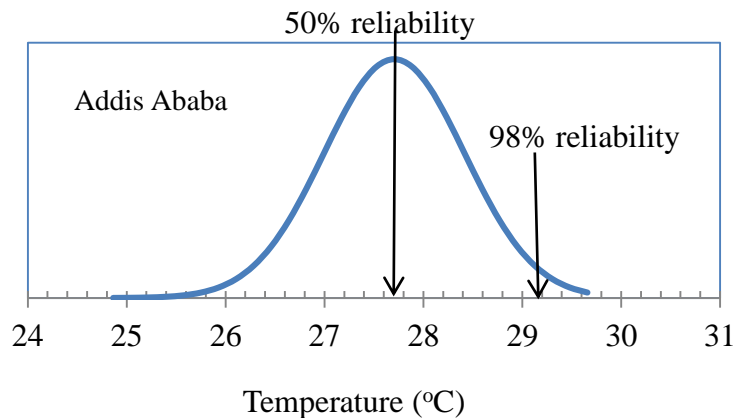

Figure 20: 50% & 98% reliability of maximum air temperature

### 4.1.2 Predication of Pavement Temperature

Different models and algorithm can calculate high pavement temperature at any depth of the pavement (Minhoto et al., 2005). For this study the common depth 20 mm below the pavement surface are chosen and low temperature are calculated at the pavement surface. Even if the algorithm is developed based on the North America atmospheric data, pavement temperature can be obtained by manipulating the main variable; air temperature and latitude, for other regions. Less significant variables; such as wind and solar absorption, are assumed constant and are given a single average value for the whole region. Therefore, considering the study area is very large, this document uses the same constant values for secondary variables and incorporates developed algorithm in the analysis.

Energy balance at the pavement surface is a transient phenomenon, continually changing with changing climatic conditions.

$$\begin{aligned} \text{Net heat flow} &= [\text{direct solar radiation}] + [\text{diffuse radiation}] \pm [\text{convection}] \\ &\pm [\text{Conduction}] - [\text{black body radiation}] \end{aligned}$$

The analysis of actual condition performed with models net heat flow and energy balance, and assuming typical values for solar absorption (0.9), radiation transmission through air (0.81), atmospheric radiation (0.7) and wind speed (4.5 m/sec). The result from section 4.1.1 can use directly or reliability factor can be added at the end of the algorithm (2<sup>nd</sup> step option). The latter provide higher value so this approach is selected for the study.

$$T_{\text{pav,h}} = (t_{\text{air}} - 0.00618\text{Lat}^2 + 0.2289\text{Lat} + 42.4)(0.9545) - 17.78 + (z\sigma_{\text{air}})$$

where:  $T_{\text{pav,h}}$  = high AC pavement temperature at 20mm from the surface

Lat = latitude of the section

$\sigma_{\text{air}}$  = standard deviation of the 7-day max. air temperature

$z$  = standard normal distribution table,  $z=2.055$  for 98%

For the low temperature binder grade, two algorithms were considered: the original SHRP, which pavement surface temperature is assumed to be equal to air temperature; and that proposed by Canadian researchers, in which pavement surface temperature is derived from air temperature. Though Canadian approach allow the designer to select stiffer binder, SHRP algorithm is chosen for this study, for study consistency.

$$T_{\text{surf}} = T_{\text{air}} + z\sigma_{\text{air}}$$

Here below is an example of pavement temperature prediction for Addis Ababa city. The data from section 4.1.1 is inserted in SHRP temperature conversion model.

For SHRP average maximum seven-day pavement temperature

$$\begin{aligned} T_{\text{pav,20mm}} &= (t_{\text{air}} - 0.00618\text{Lat}^2 + 0.2289\text{Lat} + 42.4)(0.9545) - 17.78 + (z\sigma_{\text{air}}) \\ &= (27.7^\circ\text{C} - 0.00618(9.03)^2 + 0.2289*9.03)(0.9545) - 17.78 + 2*0.71 \end{aligned}$$

Maximum pavement temperature will be 52.05°C. on the other hand, low pavement temperature can be obtained from SHRP algorithm.

$$\begin{aligned} T_{\text{surf}} &= T_{\text{air}} + (-z\sigma_{\text{air}}) \\ &= (3.2) + (-2*1.4) \end{aligned}$$

And minimum pavement temperature is 0.4°C for Addis Ababa city.

### 4.1.3 Selection of Binder Grade

As discussed earlier, Superpave performance grading is reported using two numbers. The first being the average seven-day maximum pavement temperature and the second is being the minimum pavement temperature likely to be experienced. Before getting into specific binder selection, general rules and characters for available binder grades will be discussed.

The table in figure 21 shows the standard summary table presented in the AASHTO MP 1 specification for performance graded asphalt binders. The following tips would elaborate the rules.

- If average 7-day maximum pavement temperature is greater than say “52°C” but less than “58°C”, then one should use “<58” column. The temperature directly under the “<58” cell are selected based on the minimum pavement design temperature in °C.
- The same tests is run on different simulated binder ages. Therefore, both original and RTFO aged results should be met in order to specify the binder into a certain group.
- If the difference between highest and lowest pavement are more than 90°C, then it is suggested (rule of thumb) that to select a modified binder.

Therefore, selecting asphalt binder for Addis Ababa and other regions would not be a difficult thing to do. Continuing the example using Addis Ababa, the maximum pavement temperature is 52.08°C and it is between PG52-YY<sub>11</sub> and PG58-YY<sub>22</sub>. Since selecting PG 58-YY<sub>22</sub> assure the mix-designer 98%, Addis ababa is graded as a PG 58-YY<sub>22</sub> county. The same thing goes to low pavement temperature PG asphalt binder grade. But for most of Ethiopia regions, low temperature cracking is not an issue and 50% reliability might be enough so that the final asphalt grade addis ababa will be PG58-10. Table 5 summerise the three steps for the 27 locations.

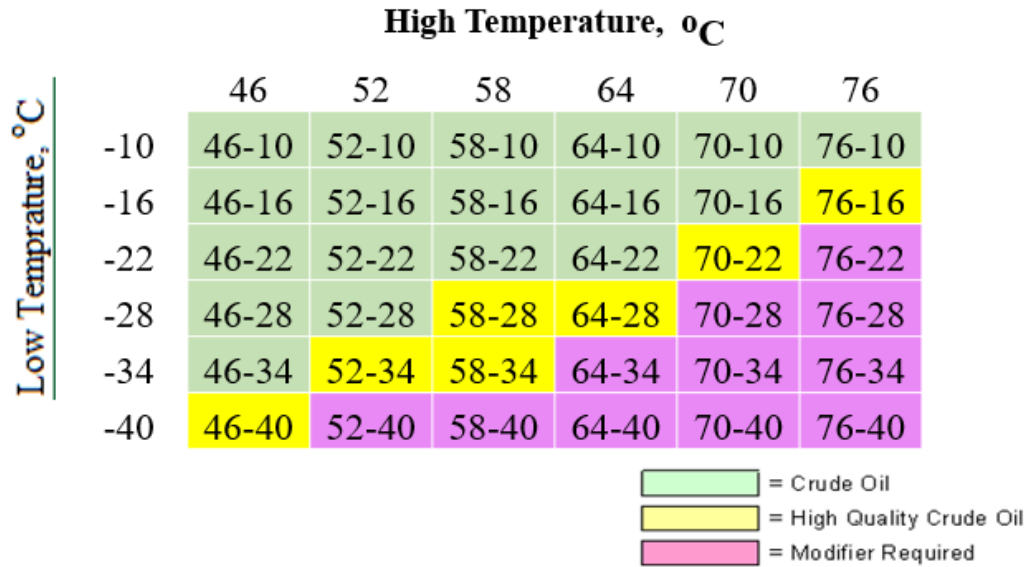

Figure 21: PG grades (Asphalt-institute, 2008)

Table 5: High and Low Air and Pavement Temperature with PG Grading

No.	Location	Ele. (m)	Lon.	Lat.	High Air Temp. (°C)		Low Air Temp. (°C)		Pavement Temp. (°C)		PG Grade
					Avg.	Std.	Avg.	Std.	High	Low	
1	Addis Ababa	2354	38.8	9.0	27.7	0.7	3.2	1.4	52.0	0.4	PG 58-10
2	Arba Minch	1207	37.6	6.1	35.5	0.8	10.5	1.2	59.2	8.3	PG 64-10
3	Assaita	430	43.6	5.9	45.8	2.8	17.1	1.0	73.2	14.4	PG 76-10
4	Awassa	1694	38.5	7.1	32.1	0.7	5.1	1.2	56.1	3.6	PG 58-10
5	Bahir Dar	1770	37.4	11.6	32.1	1.3	3.9	2.1	57.7	0.9	PG 58-10
6	Combolcha	1857	39.8	11.1	31.8	0.8	3.6	1.2	56.3	2.5	PG 58-10
7	D. Berhan	2750	39.5	9.6	23.8	0.7	-5.1	2.3	48.5	-7.2	PG 46-10
8	D.Markos	2446	37.7	10.3	27.8	0.7	4.4	1.4	52.3	2.8	PG 58-10
9	Degehabur	1070	43.6	8.2	34.8	0.7	10.1	0.2	58.8	9.9	PG 64-10
10	Dire Dawa	1180	42.5	10.0	37.2	0.7	10.7	1.0	61.2	8.8	PG 64-10
11	Gonder	1973	37.4	12.5	32.1	0.7	7.8	1.9	56.6	4.6	PG 58-10
12	Gode	290	43.6	5.9	38.4	0.4	15.4	5.0	61.2	4.9	PG 64-10
13	Gambela	500	34.6	8.3	42.2	0.7	13.4	6.2	65.7	0.9	PG 70-10

14	Gore	2033	35.5	8.1	28.9	0.9	10.4	0.7	53.4	9.3	PG 58-10
15	Jimma	1718	36.8	7.7	32.6	0.8	0.8	1.3	56.7	-0.1	PG 58-10
16	Jinka	1373	36.6	5.8	32.5	0.8	11	1.1	56.5	9.0	PG 58-10
17	KibreDehar	505	44.3	6.7	37.6	0.6	14.9	0.8	61.0	12.8	PG 64-10
18	Mankush		35.3	11.3	40.8	0.5	12.7	4.0	64.3	4.5	PG 70-10
19	Mega	1820	38.3	4.1	28.8	1.3	10.2	1.0	53.6	8.4	PG 58-10
20	MehalMeda	3084	39.7	10.3	21.9	0.5	0.2	0.9	46.2	0.1	PG 52-10
21	Mekele	2257	39.5	13.5	29.0	0.7	4.5	2.0	53.7	1.5	PG 58-10
22	Metahara	944	39.9	8.9	38.5	0.6	6.9	1.5	62.1	4.6	PG 64-10
23	Negele	1544	39.6	5.4	31.8	0.6	5.3	1.1	55.2	4.1	PG 58-10
24	Nekemt	2080	36.5	9.1	29.6	0.6	7.8	2.3	53.7	3.8	PG 58-10
25	Robe	2480	40.1	7.1	25.4	0.5	2	0.8	49.2	1.7	PG 52-10
26	Shire	1897	38.3	14.1	32.6	0.7	7	1.6	57.2	4.5	PG 58-10
27	Ziway	1640	38.7	7.9	31.6	0.6	6.1	2.1	55.3	2.8	PG 58-10

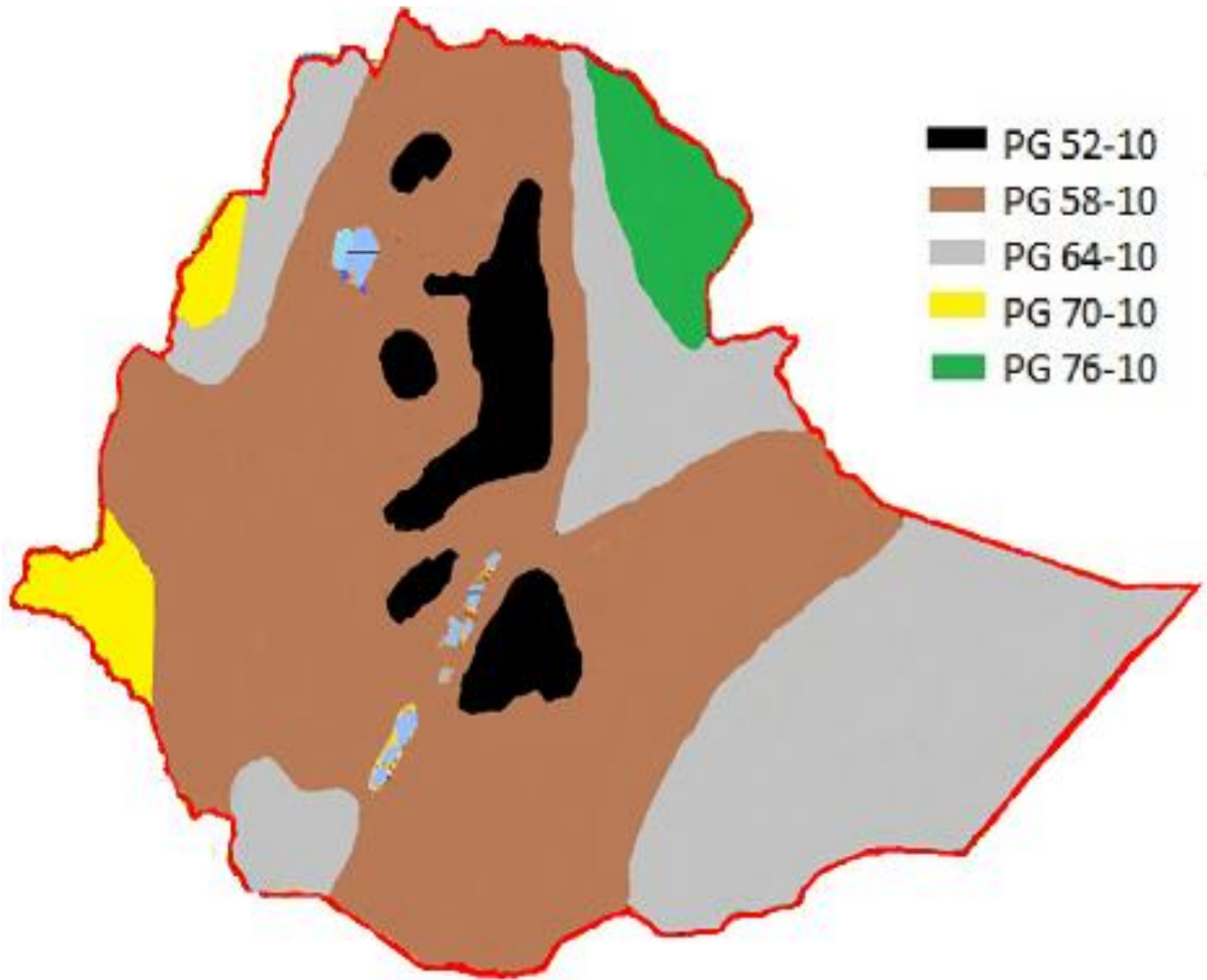

Figure 22: Performance Grade Map of Ethiopia

## 4.2 Analysis and Interpretation of Asphalt Test Results

The introduction of PG technology requires high personnel training cost and expensive equipment's; therefore, the implementation process would be difficult for a country such as Ethiopia. This section assesses the asphalt binders, which are currently used for pavement construction, by DSR (Superpave method equipment) and present the equivalent meaning of PGXX-YY. Most of the correlations are explained using linear regression model except for PG-penetration, which also incorporate polynomial regression. The strength of the relationships is checked using PEARSON function on excel sheet.

### 4.2.1 Conventional Test Methods Result

Most of the conventional test methods are empirical and have poor relation with the performance of the pavement. Collected samples are first tested for penetration test to confirm the agencies data. All the resulted penetration test values confirm that the samples are between the specifications ranges.

As the penetration grade increase, the softening point decreased from 54.1°C for 40/50 penetration grade to 47°C for 80/100, indicating that asphalt binders became more viscous at lower temperature. The ductility test result shows increment, showing that the binders are more flexible and would be better candidate for cold areas roadways. However, flash point and solubility did not show any change. Table 6 present summarized conventional test result.

Table 6: Sample asphalt and source

Binder Type	Penetration (dmm)	Softening point (°C)	Ductility (cm)	Flash point (°C)	Solubility (%)	Mass Change (%)
40/50 E	44	54.1	100+	305.0	99.81	0.02
40/50 C	47	53.5	100+	307.7	99.83	0.02
60/70 E	66	50	100+	304.4	99.72	0.03
60/70 A	64	47	100+	302.0	99.80	0.03
80/100	96	44	100+	300.0	99.70	0.04

*N.B: In order to differentiate the source of the same grade, source initials are displayed with the grades*

## 4.2.2 Superpave Test Method Results

Since this study is focuses on neat asphalt binders, the first two tests of PG methods; which are amplitude and frequency sweep test, are not required as an input for the assessment. Nevertheless, the results can provide an insight about the crossover frequency and linear viscoelastic range, which in turn indicates the quality of the source and geological formation information.

### 4.2.2.1 Amplitude Sweep Test

Asphalt binder is a viscoelastic material which behavior is a continuous function of time and temperature. So performing test in a linear viscoelastic range assures that the test is repeatable and results can be obtained using mathematical model. Therefore, AST provide LVE-range by limiting the strain value so that asphalt binder for which the stress-strain behavior is linear and independent of rate of loading and temperature. A constant value of  $G^*$  is observed before it begin to decline and LVE strain limit can be calculated as the point beyoned which the measured value of  $G^*$  decreased to 95% of its Zero-strain. Figure 23 shows 60/70 pen-grade AST result as the complex modulus is aligned to Y-axis and strain(%) in X-axis.

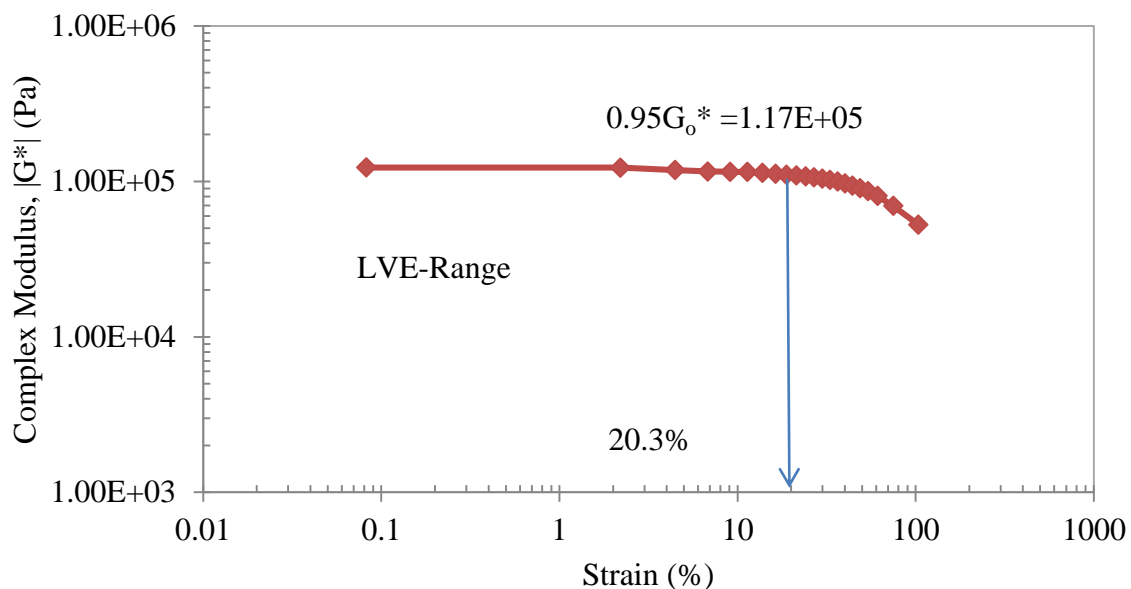

Figure 23: LVE-range of 60/70 E original @ 37.8°C

The LVE-range changes with the stiffness of the asphalt binder changes at constant temperature. the lower grades (80/100) show a larger LVE-range relative to the stiffer grades; indicating it is more flexible and have better performance for the lower temperature regions.

Table 7: Summarized LVR value

Binder Type	Temperature (°C)	Original			RTFO-Aged		
		Plateau G* (Pa)	0.95G* (Pa)	LVE (%)	Plateau (Pa)	0.95G* (Pa)	LVE (%)
40/50 E	21.1	3.79E+06	3.60E+06	2.73	6.49E+06	6.17E+06	0.49
	37.8	1.64E+05	1.56E+05	16.10	3.58E+05	3.40E+05	2.7
	54.4	8.76E+03	8.32E+03	59.40	2.29E+04	2.17E+04	36.2
40/50 C	21.1	3.01E+06	2.86E+06	1.79	6.42E+06	6.10E+06	0.42
	37.8	1.50E+05	1.42E+05	13.90	3.53E+05	3.35E+05	2.15
	54.4	7.43E+03	7.06E+03	51.6	2.11E+04	2.00E+04	34.4
60/70 E	21.1	2.35E+06	2.24E+06	2.85	3.31E+06	3.14E+06	2.9
	37.8	1.22E+05	1.16E+05	20.3	1.81E+05	1.72E+05	6.29
	54.4	5.86E+03	5.50E+03	56.00	1.09E+04	1.04E+04	42.1
60/70 A	21.1	3.22E+06	3.06E+06	1.21	5.44E+06	5.17E+06	1.34
	37.8	1.48E+05	1.40E+05	18.63	2.55E+05	2.43E+05	4.9
	54.4	7.76E+03	7.37E+03	62.20	1.74E+04	1.66E+04	42.3
80/100	21.1	8.66E+05	8.23E+05	6.47	1.44E+06	1.37E+06	3.57
	37.8	3.63E+04	3.45E+04	27.30	8.54E+04	8.11E+04	9.3
	54.4	2.80E+03	2.66E+03	83.90	6.37E+03	6.05E+03	50.6

The input strain for PG determination is based on AST at high temperature. But AASHTO T 315 suggest 12% for original binder or 10% for aged binder strain to create a common and reliable test method.

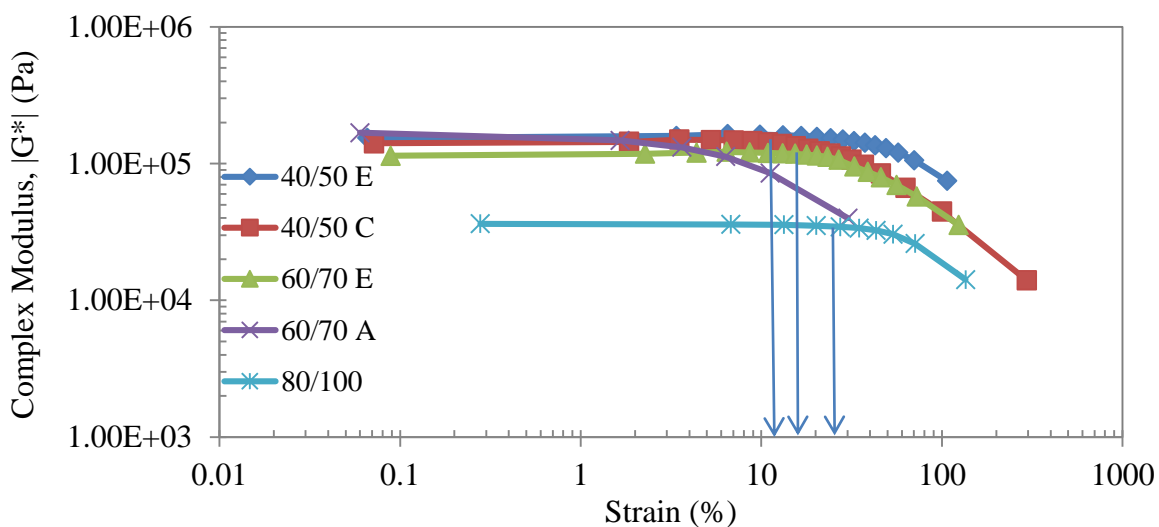

Figure 24: Change of LVE-range with stiffness @37°C

#### 4.2.2.2 Frequency Sweep Test

Following AST, frequency sweep test was conducted by maintaining 1% strain from AST for intermediate (21.1°C and 37.8°C) and high (54.4°C) temperature. The frequency varies from 25Hz to 0.1Hz to represent the damaging effect of the traffic load. The resulted parameter can be manipulated to construct Master curve; to characterize the binder for larger range of temperature and frequency, and Black Space Diagram; which evaluate the effect of modifying agent on the binder. As figure 25 shows, the complex modulus decreases as the frequency or rate of loading is decreases. On the contrary, phase angle increases as the frequency decreases to 0.1 Hz, indicating the binder are behaving more like viscous liquid.

Generally, FST data results are mainly used for constructing Master Curve using time-temperature superposition principle, the change in complex modulus and phase angle can be investigated and shifted to a defined reference temperature, in this case 21.1°C.

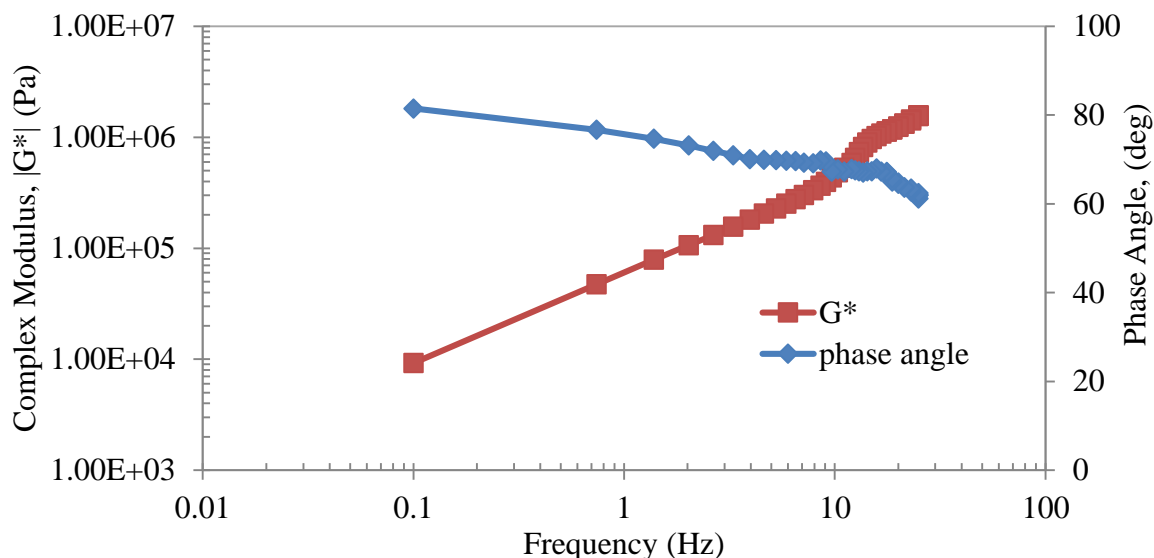

Figure 25: Complex modulus and Phase angle Vs. Frequency for 40/50E @37.8°C

Binder master curve graph extrapolate the test result up to very high frequency ( $10^{15}$  Hz) and very low frequency ( $10^{-6}$  Hz) indicating the whole transition of asphalt binder from glassy region to fluid viscous. The crossover frequency; a frequency at which storage and loss modulus crosses ( $\tan\delta=1$ ), defines the beginning of rubbery plateau and decreases with increasing hardness. At defining temperature, it can be correlated with asphaltene content and provide information on chemical formation (Anderson et al., 1994).

The sigmoidal function is used to fit and smoothen the test results at different temperature.

$$\log(G^*) = \delta - \frac{\alpha}{1 + e^{(\beta + \gamma \log(f_r))}} \dots\dots\dots (1) \text{ Modulus M.C}$$

Where: |G\*|: complex shear modulus

f<sub>r</sub>: reduced frequency

γ, β: parameters describing the shape of sigmoidal function

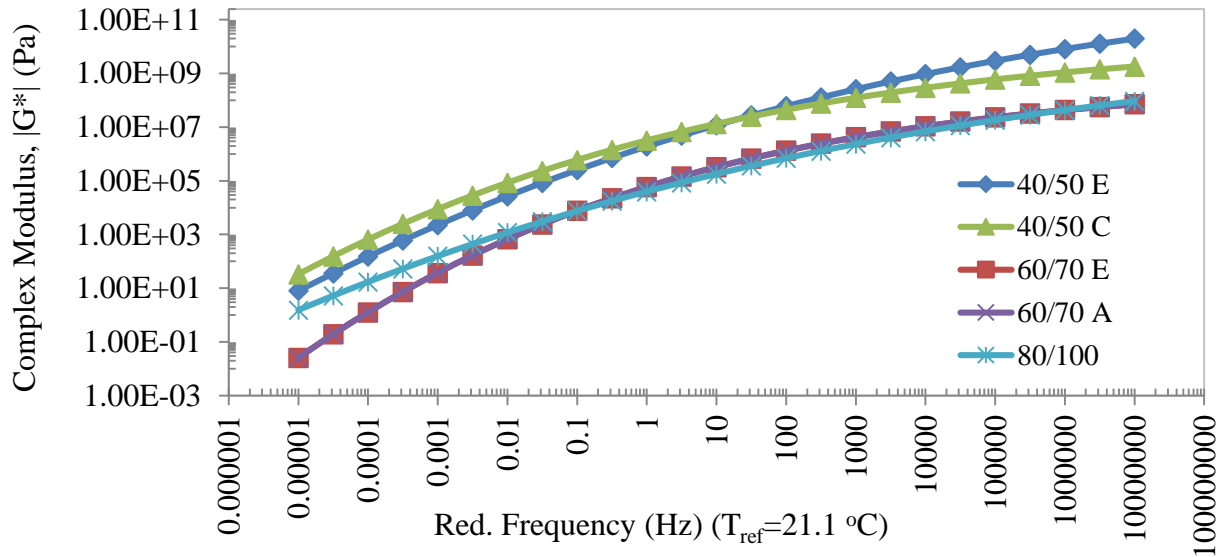

Figure 26: Complex Modulus Master Curve (Original)

At the original binder state, the master curves indicate that both type 40/50 pen-grade has higher stiffness throughout the frequency range than the rest of the binders.

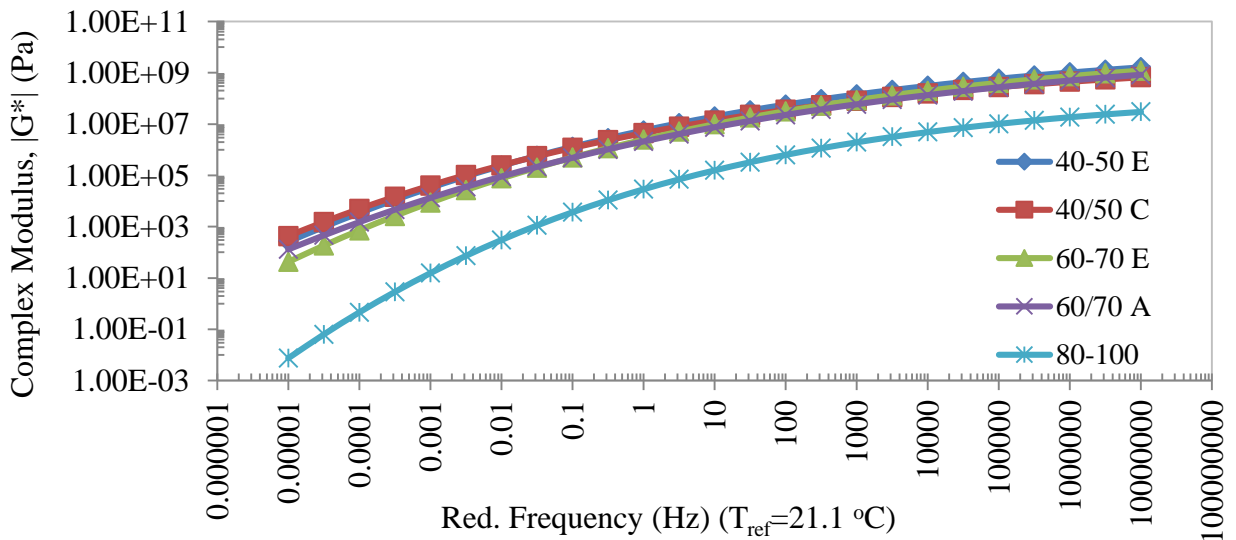

Figure 27: Complex Modulus Master Curve (RTFO aged binder)

Except pen-grade 80/100, all binder types have nearly similar stiffness throughout the range. Additionally, phase angle master curve can be constructed using the same concept as binder and decreasing phase angle indicate the elasticity of the binder.

$$\phi = -90 * \delta\alpha - \frac{\exp(\beta + \delta(\log f_r))}{[1 + e^{(\beta + \delta(\log f_r))}]^2} \dots\dots\dots(2) \text{ Phase angle M.C}$$

Where  $\phi$ : phase angle  
 $\delta$ : minimum modulus value  
 $\delta + \alpha$ : maximum modulus value

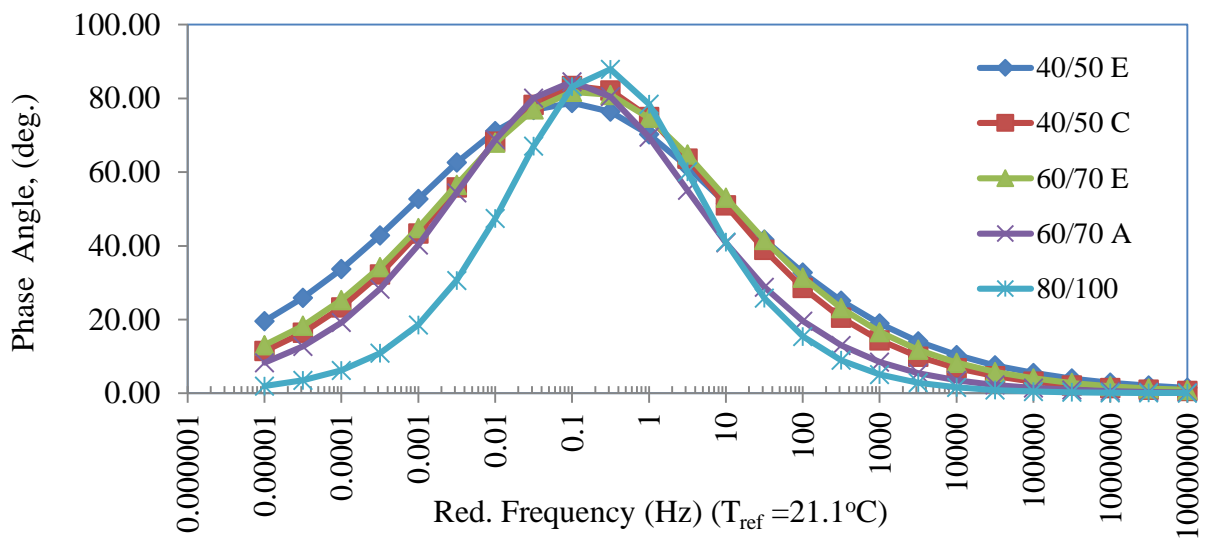

Figure 28: Phase angle master curve (original)

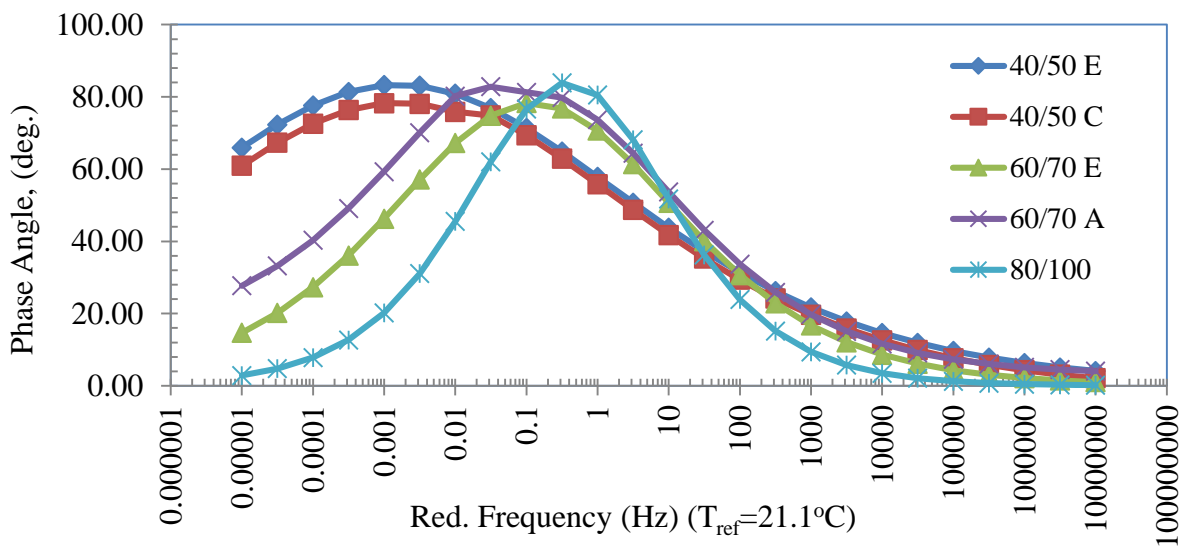

Figure 29: Phase Angle Master Curve (Aged)

Asphaltenes content increase at high rate during construction and increase gradually with the time. Air blowing also results a considerable increase in the asphaltene content and decrease in the aromatics content. As a result, aged asphalt has grater stiffness compared to original binders.

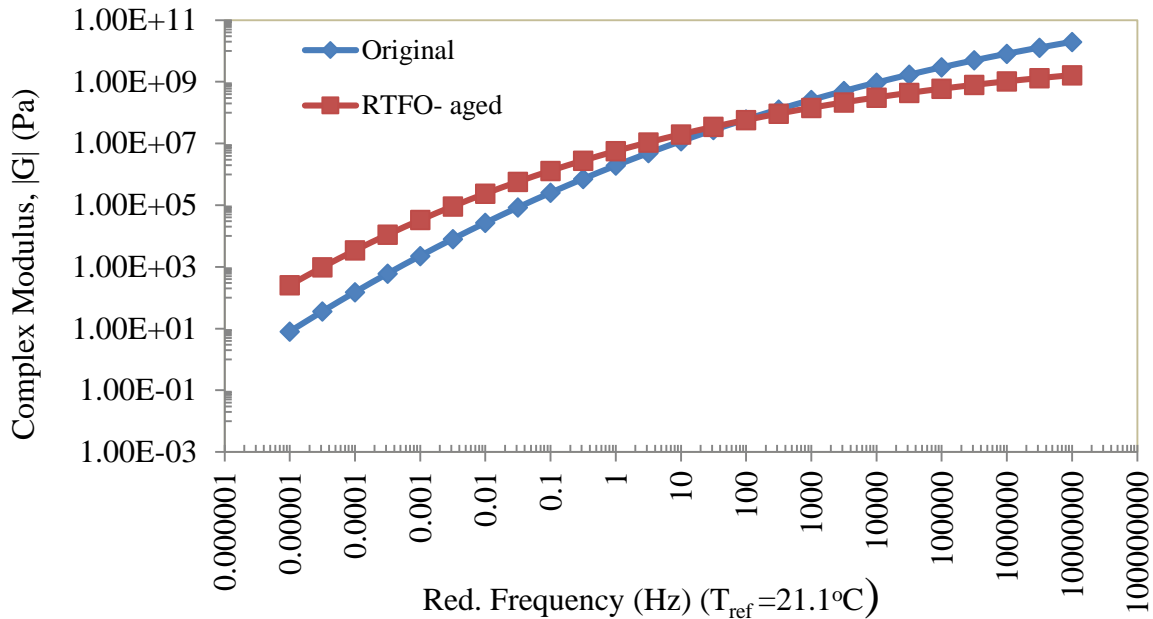

Figure 30: Aging effect on 40/50 E

Additionally, black space diagram can be constructed from frequency sweep test and for neat asphalt binders; it is used to ckeck data consistency.

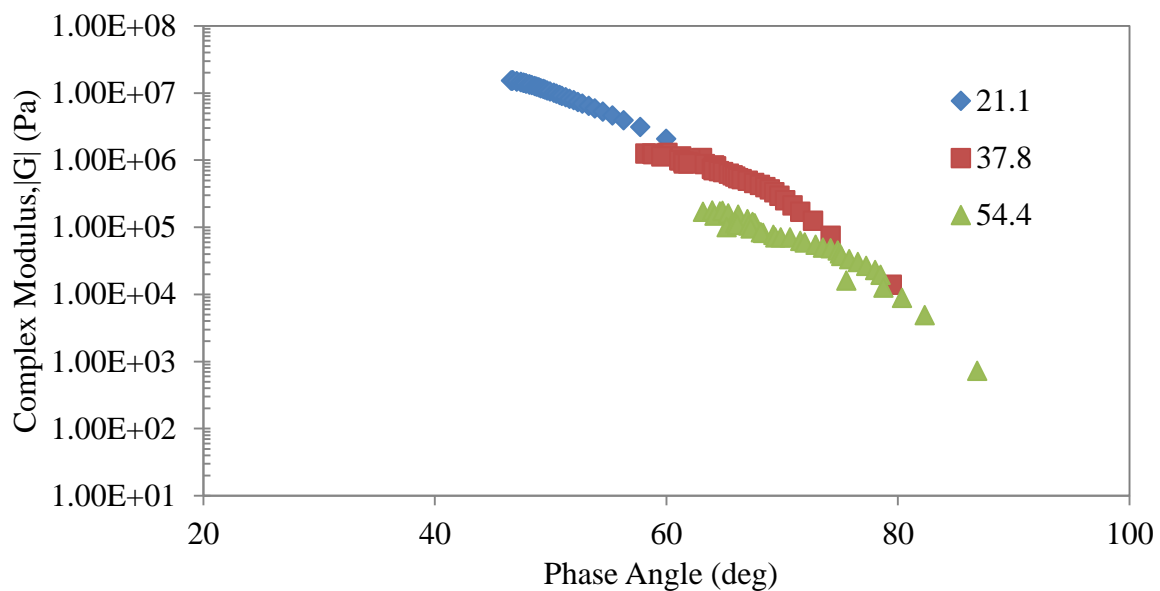

Figure 31: Black Space diagram of 60/70 E

### 4.2.2.3 Performance Grade Determination

PG determination test is conducted at high temperature with a 6°C temperature increment. If the sample passes the first selected temperature, then it will continue to test for the next adjusted temperature. The final rheological parameter  $G^*/\sin\delta$ , was believed to indicate the resistance of asphalt binder for permanent deformation at high environmental temperature before MSCR test was discovered. This study uses the parameter  $G^*/\sin\delta$  to identify the maximum temperature that the asphalt binder could meet the minimum criteria of AASHTO M-320.

As presented on the graph, penetration grade 80/100 failed the minimum criteria of AASHTO after 58°C for both aged and unaged asphalt binder sample. Unaged minimum criteria 1kPa assures against tenderness mixture while aged 2.2kPa minimum criteria indicate the resistance of permanent deformation. Therefore, equivalent PG grade for 80/100 penetration graded asphalt is PG58-YY. Critical temperature; the exact temperature at which  $G^*/\sin\delta$  is below 1kPa, will be displayed with the other parameters.

Table 8: PG determination test results of 80/100 (original)

Temperature (°C)	Phase Angle (deg.)	Complex Modulus (kPa)	Elastic Modulus (kPa)	Viscous Modulus (kPa)	$G^*/\sin\delta > 1\text{kPa}$ (kPa)	Remark
52	86.19	3.75	0.25	3.74	3.76	Pass
58	87.29	1.40	0.07	1.40	1.40	Pass
64	88.01	6.30	0.02	0.63	0.63	Fail
Pass-Fail Temperature (°C)		60.5				
PG Grade		58				

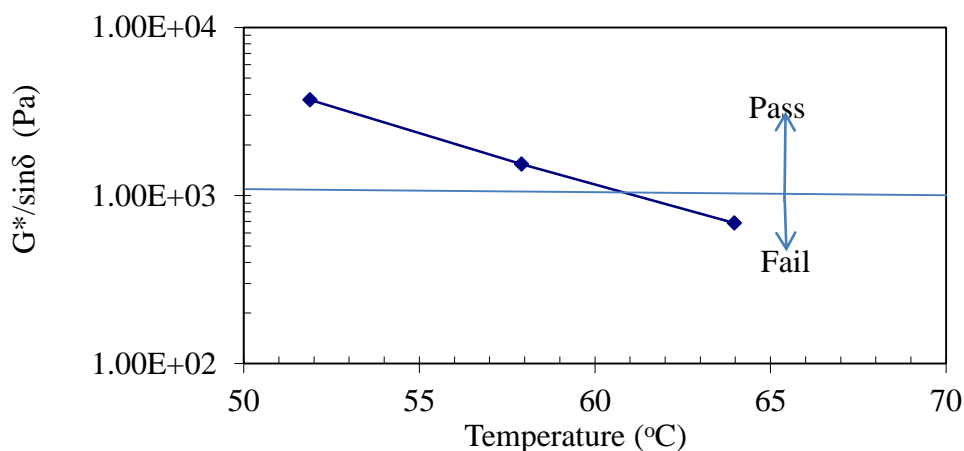

Figure 32: 80/100 pen-grade PG determination test result (Original)

Table 9: PG determination test results of 80/100 (aged)

Temperature (°C)	Phase Angle (deg.)	Complex Modulus (kPa)	Elastic Modulus (kPa)	Viscous Modulus (kPa)	$G^*/\sin\delta > 2.2\text{kPa}$ (kPa)	Remark
52.03	82.95	8.79	1.08	8.73	8.86	Pass
57.95	85.13	3.79	3.22	3.78	3.81	Pass
64.02	86.76	1.42	8.03	1.42	1.43	Fail
Pass-Fail Temperature (°C)	61.3					
PG Grade	58					

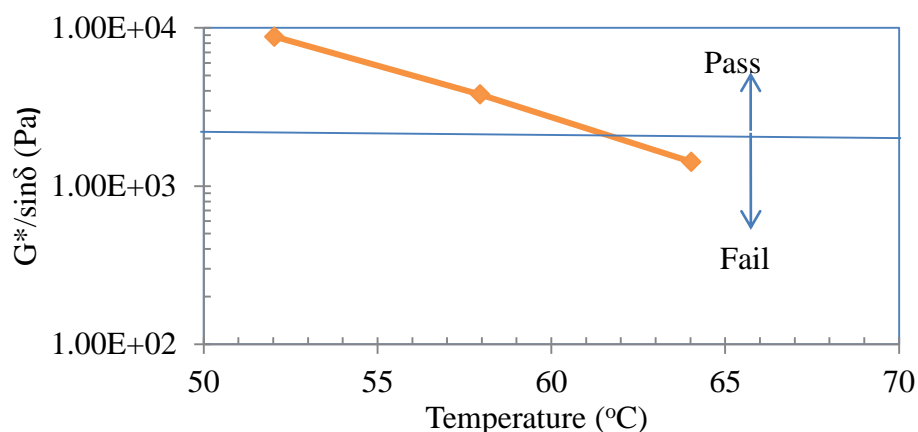

Figure 33 : 80/100 pen-grade PG determination test result. (Aged)

Therefore, the correlation of PG and conventional grading system can be decided by determining the maximum temperature at which the minimum AASHTO criteria is achieved. Table 10 summarize the result of all types of asphalt binder and provide PG equivalent for penetration grades.

Table 10: PG Equivalence for pen-graded asphalt

Penetration Grade	Original Sample		RTFO Aged sample		PG Category
	Temperature (°C)	$G^*/\sin\delta > 1\text{kPa}$ (kPa)	Temperature (°C)	$G^*/\sin\delta > 2.2\text{kPa}$ (kPa)	
40/50 E	64	2.00	70	2.48	PG64-YY
40/50 C	64	1.90	70	2.42	PG64-YY
60/70 E	64	1.63	64	2.42	PG64-YY
60/70 A	70	1.10	64	2.87	PG64-YY
80/100 E	58	1.53	58	3.67	PG58-YY

Other similar western experimental researches indicates that penetration grade 40/50 has an equivalent performance grade PG70-10/16 while Middle East researches conclude that most of the Arabian Gulf refineries, including products, 40/50 pen-grade, has a capacity of 64°C. According to the data on table 10, the rut resistance parameter  $G^*/\sin\delta$  does not show significant difference between pen-grade 60/70 and 40/50. This leads to the fourth and the last DSR test program; MSCR.

#### 4.2.2.4 Multiple Stress Creep and Recovery

PG asphalt binder rutting resistance parameter  $G^*/\sin\delta$  is based on complex modulus and doesn't correlate well with field rutting measurements. That is because  $G^*$  is measured in the linear viscoelastic range and rutting is a non-linear failure. Nevertheless,  $G^*/\sin\delta$  work well for unmodified binders and this research uses the MSCR test data for ranking neat asphalt binders.

Most of Ethiopian regions pavement temperature does not exceed 64°C. So why bother and test the binders at 70°C or 76°C? Why suggesting Grade Bumping for high traffic zones? MSCR provide a solution by including the parameter  $J_{nr}$  (non-recoverable creep compliance); which measures the amount of residual strain left in the specimen after repeated creep and recover, for RTFO aged binder. The determination of PG temperature reduces the efforts required for testing the samples for too many temperature labels.

Table 11: MSCR testing temperature

Penetration Grade	PG	Testing Temperature (°C)			
		52	58	64	70
40/50 E	64	52	58	64	70
40/50 C	64	52	58	64	70
60/70 E	64	52	58	64	-
60/70 A	64	52	58	64	-
80/100 E	58	46	52	58	-

Other parameters such as percent recovery; a measure of how much the sample returns to its previous shape and percent difference in  $J_{nr}$ ; which shows the stress sensitivity of the binder, between 0.1 kPa and 3.2 kPa stress are also calculated. Figure 34 presents a total strain of 60/70 pen-grade for MSCR-test at different testing temperature.

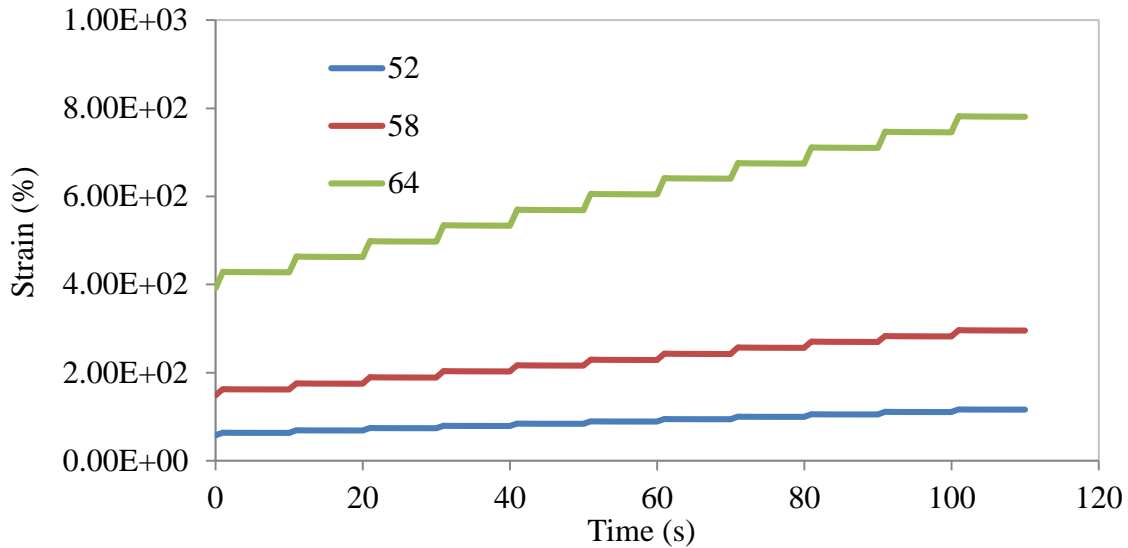

Figure 34: Temperature effect on MSCR-100 total strain for 60/70E asphalt binder

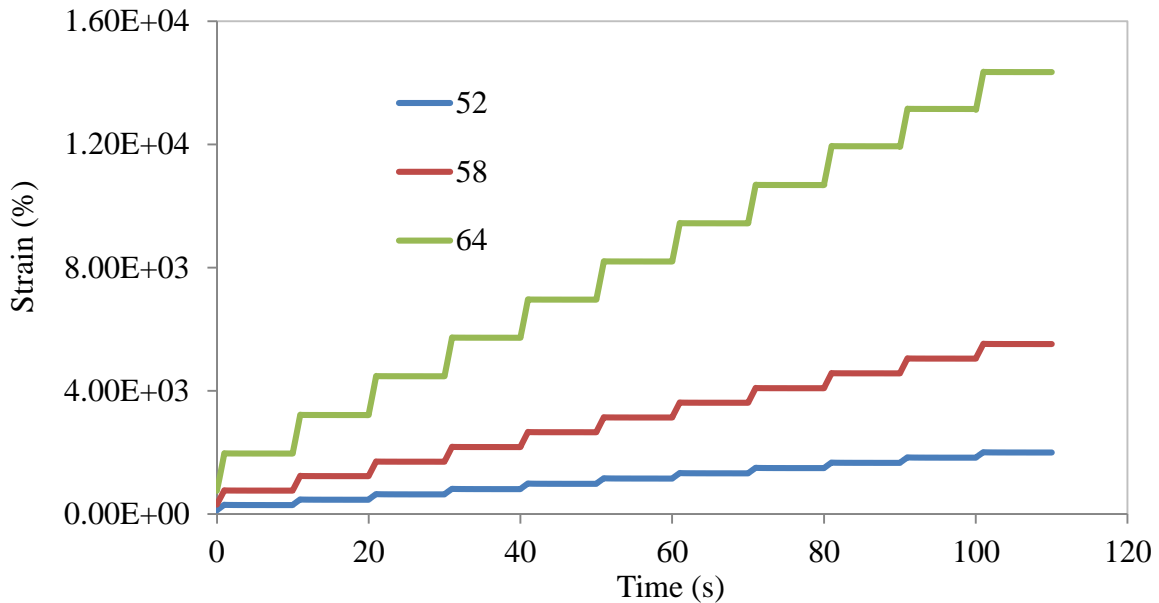

Figure 35: Temperature effect on MSCR-3200 total strain for 60/70E asphalt binder

The standard grade should be based on  $J_{nr}$  value of existing neat binder ( $4.0 \text{ kPa}^{-1}$ ). If heavy traffic is expected the specification requirement is changed, i.e. a lower  $J_{nr}$  value is required to reflect the resistance of the pavement for the coming traffic load, but testing is still done at maximum temperature. This approach eliminates grade bumping after PG determination, for high traffic or slow moving vehicles road network. Table 12 present AASHTO 332, which specify maximum  $J_{nr}$  values for the corresponding traffic load (ESALs) and speed.

Table 12: Traffic Designation AASHTO M-332

Traffic Designation	Traffic level (ESALs)	Load rate (km/h)	$J_{nr3.2}$ ( $kPa^{-1}$ )
Standard Traffic “S”	<10 million	>70	4.0
Heavy Traffic “H”	10>30 million	20-70 (slow)	2.0
Very Heavy Traffic “V”	>30 million	< 20	1.0
Extremely Heavy Traffic “E”	>30 million	< 20 (standing )	0.5

Non-recoverable creep compliance ( $J_{nr}$ ) is calculated by dividing unrecoverable strain ( $\gamma_r$ ) to the applied stress ( $\tau$ ). The  $PR_{3.2}$  which give us information about binder elastic behavior is recoverable strain/ Peak strain times 100. A final summary of MSCR test results for each penetration graded asphalt binder are presented in table 13.

Table 13: Summary of MSCR  $J_{nr}$  results

Binder Type	Temperature (°C)	$J_{nr}$ ( $kPa^{-1}$ )		$J_{nr-diff}$ (kPa)	PR (%) $\tau = 3.2$	PG Equivalent MSCR
		$\tau = 0.1$	$\tau = 3.2$			
40/50 E	52	0.26	0.27	3.852	11.28	PG 52E-YY
	58	0.76	0.78	3.033	4.73	PG 58V-YY
	64	1.91	2.07	8.602	1.57	PG 64S-YY
	70	4.23	4.70	11.064	0.46	-
40/50 C	52	0.32	0.35	3.410	10.21	PG 52E-YY
	58	0.88	0.93	5.000	4.33	PG 58V-YY
	64	1.99	2.21	11.055	1.37	PG 64S-YY
	70	4.48	5.02	12.053	0.42	-
60/70 E	52	0.53	0.54	1.070	6.65	PG 52V-YY
	58	1.34	1.48	10.241	2.41	PG 58H-YY
	64	3.54	3.96	11.749	0.70	PG 64S-YY
60/70 A	52	0.47	0.49	4.255	7.59	PG 52E-YY
	58	1.02	1.11	8.824	3.16	PG 58H-YY
	64	3.05	3.39	11.213	1.21	PG 64S-YY
80/100	46	0.34	0.35	1.700	9.77	PG 42E-YY
	52	0.97	1.02	5.804	3.81	PG 52H-YY
	58	2.64	2.86	8.417	1.11	PG 58S-YY
	64	6.74	7.57	12.286	0.04	-

The combination of environmental impact with traffic loading and loading condition should be considered on investigating rheological properties of asphalt binder. Neat binders have linear strain response and are less sensitive to stress level of the test. All  $J_{nr-diff}$  values are way below the limit 75%.

The non recoverable compliance ( $J_{nr}$ ) increases as the testing temperature increases, for each asphalt grade. Therefore,  $J_{nr}$  values at 3.2 kPa are compared with AASHTO 332. If tested samples are compared against Addis Ababa and Arba Minch Pavement design temperature as an example; binders can be selected for standard traffic load before construction or acceptable traffic loading (ESALs) can be suggested for constructed pavements.

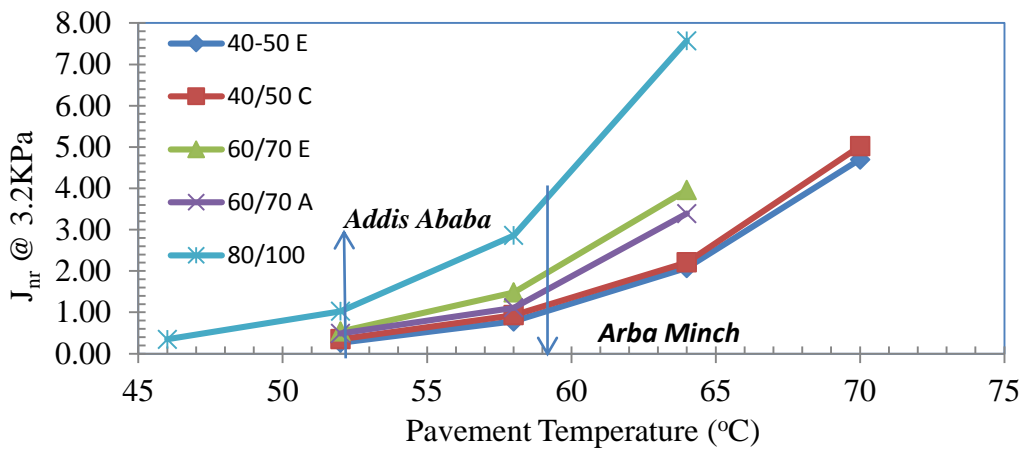

Figure 36: Non-recoverable compliance change with Temperature

Referring table 5, the temperature analysis provides 59.2°C maximum pavement temperature for Arba-Minch and 52.07°C for Addis Ababa. The graph shows that, selecting 80/100 pen- graded asphalt for Arba-Minch, even for standard traffic loading and speed, would be risky. On the other hand, for standard and heavy traffic loading type, 80/100 would perform well in Addis Ababa.

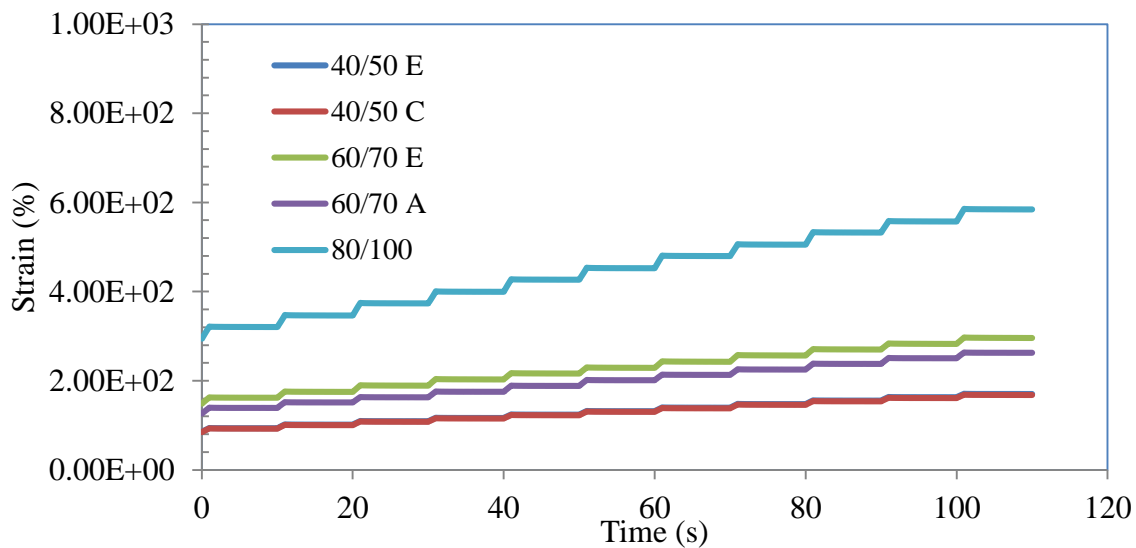

Figure 37: Effect of stiffness on total strain of 0.1kPa (58°C)

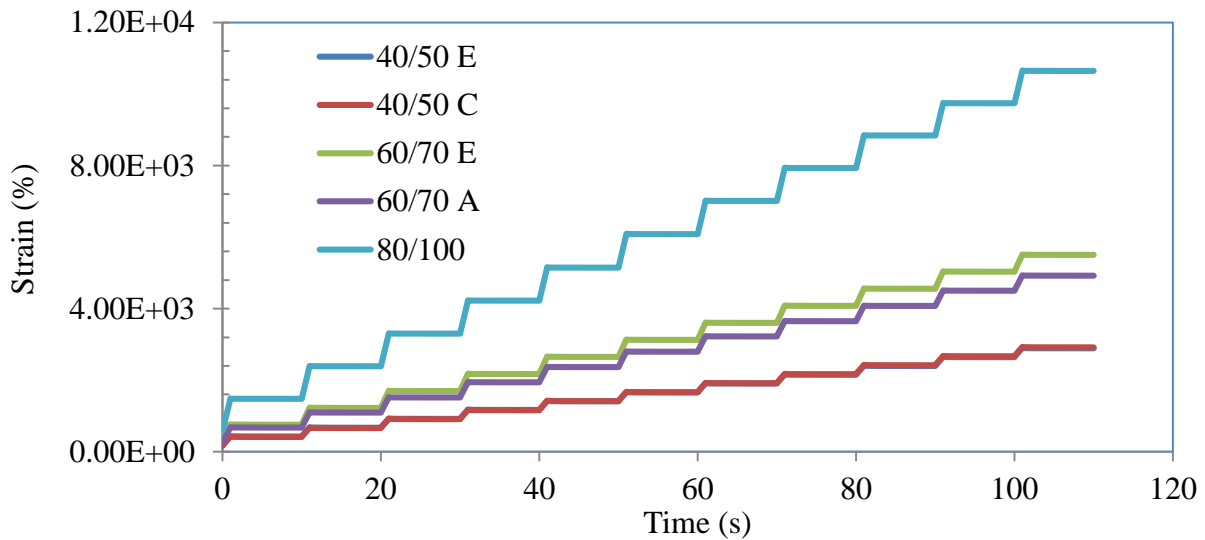

Figure 38: Effect of stiffness on total strain @ 3.2kPa (58°C)

#### 4.2.2.5 Rotational Viscometer Test

The viscosity obtained from rotational viscometer at different temperature are used; (i) to determine the viscosity of asphalt binder at pumping and handling temperature, and (ii) to prepare viscosity-temperature charts that can be used to determine mixing and compaction temperature. AASHTO M-320 place an upper limit ( $<3.0$  Pa-s) on the viscosity at 135°C.

For unmodified binders, the following range of equi-viscous temperature has been founded acceptable for selecting mixing and compaction:(Asphalt-Institute, 2007)

- Mixing-Temperature at which the viscosity is  $0.17 \pm 0.02$  Pa-s.
- Compaction- Temperature at which the viscosity is  $0.28 \pm 0.03$  Pa-s.

Summarized dynamic viscosity at 60°C, 135°C and 165°C for each penetration graded asphalt binders are presented in table 14.

Table 14: Summary Viscosity test results

Binder Type	Apparent viscosity 60 °C	Viscosity (Pa.s)		Mix Temperature (°C)	Compaction Temperature (°C)	Remarks (< 3Pa.s)
		135 °C	165 °C			
40/50 E	401.2	0.569	0.143	159-163	147-152	Pass
40/50 C	383.5	0.525	0.141	159-163	145-149	Pass
60/70 E	199.8	0.471	0.139	158-162	145-149	Pass
60/70 A	260	0.498	0.141	159-163	146-150	Pass
80/100	86.7	0.406	0.125	155-159	142-146	Pass

### 4.3 Correlation of Conventional and PG Grading System

The asphalt binder with the same penetration grade might have different rheological properties due to refineries operational condition and geological formation process. Table 10 only shows the equivalent PG grade of asphalt binders. Since minimum criteria are achieved at different temperature, comparison and correlation assessment is difficult. The solution that this study come up with is to measure and compare the parameter  $G^*/\sin\delta$  at constant temperature (64°C). The assessment of the strength between the two methods binder test are conducted using the square of the Pearson product moment correlation coefficient through data points in a known  $y$ 's and known  $x$ 's. Excel RSQ returns  $r^2$  which is the square of this correlation coefficient.

$$r = \frac{\sum (x - \bar{x})(y - \bar{y})}{\sqrt{\sum (x - \bar{x})^2 \sum (y - \bar{y})^2}}$$

Where:  $r$  is Pearson correlation

$x$ ,  $x'$  and  $y$ ,  $y'$  are samples and mean

#### 4.3.1 Correlation between Penetration and PG determination

Currently functioning penetration grading system use the mix designer experience to predict the performance of asphalt binder for a certain location. The mix designer should have enough knowledge about the location's climatic conditions and the behavior of suggested binders. On the contrary, PG grading is based on predicted pavement temperature from actual air temperature.

PG determination parameter  $G^*/\sin\delta$  have different values as the temperature varies. Therefore, this study selects one temperature (64°C) and compares the relative stiffness of the asphalt binders. The correlation might be linear, polynomial or exponential depending on the required strength between the independent and dependent variable.

Table 15: Penetration values and  $G^*/\sin\delta$  @ 64°C

Binder Type	Penetration test	$G^*/\sin\delta$ @ 64°C (kPa)	
		Original	Aged
40/50 E	44	2.00	5.13
40/50 C	47	1.90	5.05
60/70 E	66	1.63	2.42
60/70 A	64	2.55	2.87
80/100 E	96	0.654	1.40

The figure 39 shows that the linear relation between penetration values and original binders  $G^*/\sin\delta$  ( $r_o^2=0.55$ ) is very weak relative to aged samples ( $r_r^2=.88$ ). Polynomial fitting also shows weak strength for original binder ( $r_o^2=0.57$ ) but  $r_r^2=0.98$  for aged. Relating penetration grade with PG determination test on RTFO aged samples will mislead the user to erroneous conclusion. This is because, in laboratory the aging system (temperature and pressure) are controlled and perfect. Therefore, resulted  $G^*/\sin\delta$  account stiffness increment due to oxidation and volatilization. But the actual mix-plant usually perform below the controlled laboratory environment and the expected  $G^*/\sin\delta$  for asphalt binder after mixing, might not be similar with the laboratory rut resistance parameter.

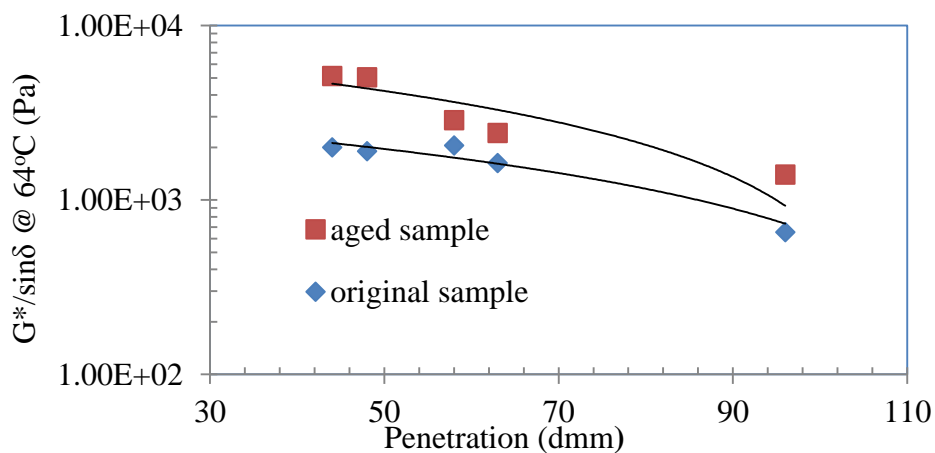

Figure 39: Penetration Vs.  $G^*/\sin\delta$  (linear fitting)

Penetration test depends on testing equipment dimension and sample size. Different values can have observed at one test and usually the average value is reported. Therefore, it is difficult to provide exact equation that relate penetration grade with PG rutting resistance parameter. But simple linear equation can be develop for the samples tested for this study. Equation 1 relates penetration value to original rut resistance parameter while equations 2 relate it with aged rut resistance parameter.

$$(G^*/\sin\delta)_o = -25.01(\text{pen-value}) + 3331.49 \quad [\text{Linear}] \quad (1)$$

$$(G^*/\sin\delta)_o = -1.01(\text{pen-value})^2 + 116.3(\text{pen-value}) - 1230.98 \quad [\text{polynomial}] \quad (2)$$

$$(G^*/\sin\delta)_r = -75.03(\text{penetration value}) + 8130.8 \quad [\text{Linear}] \quad (3)$$

$$(G^*/\sin\delta)_r = 1.6(\text{pen-value})^2 - 303.2(\text{pen-value}) + 15495.4 \quad [\text{polynomial}] \quad (4)$$

While the subscript “o” and “r” represent original and RTFO aged binder state respectively.

### 4.3.2 Correlation between Softening Point and PG determination

Both tests are high temperature tests and indicate the relative flow resistance of asphalt binder. It is assumed that the higher the softening point, the stiffer the material. The conceptual difference between these two are; softening point indicate the temperature that the asphalt binder flows under the applied load (Ball) and PG determination indicate the maximum temperature which the asphalt still behaves within LVE-range.

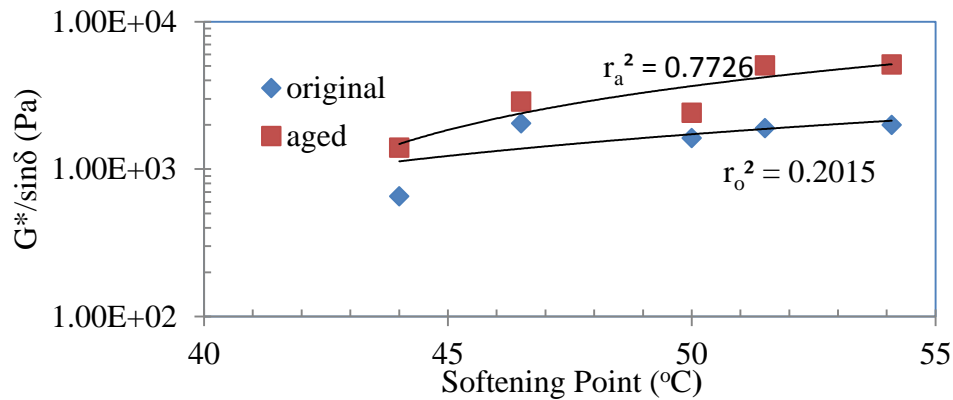

Figure 40: Softening point vs  $G^*/\sin\delta$  @ 64 °C

### 4.3.3 Correlation between Penetration and MSCR

The range of penetration grade is large and test results might not be within the range yet, graded as specific penetration asphalt grade. PG determination result provide relatively close  $G^*/\sin\delta$  for 40/50 and 60/70 pen-grade asphalt. Additional SHRP test; MSCR, provide better division between those two grades. Therefore, MSCR and penetration values relation provide basic information to select asphalt binder for a specific location.

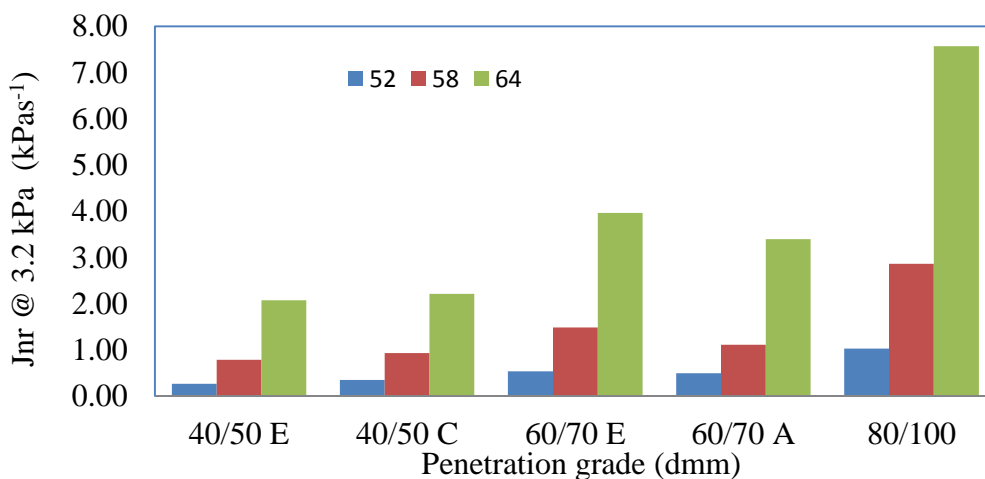

Figure 41: Penetration grade Vs non-recoverable compliance ( $J_{nr}$ ) @ 3.2kPa

#### 4.3.4 Correlation between Softening Point and Viscosity

The result of softening point can be related more with apparent viscosity due to the similarity of testing temperature. The correlation coefficients,  $r^2=0.82$  indicate that, there is a strong relationship between softening point and apparent viscosity. Additionally, softening point and viscosity at 135°C relation strength were evaluated.

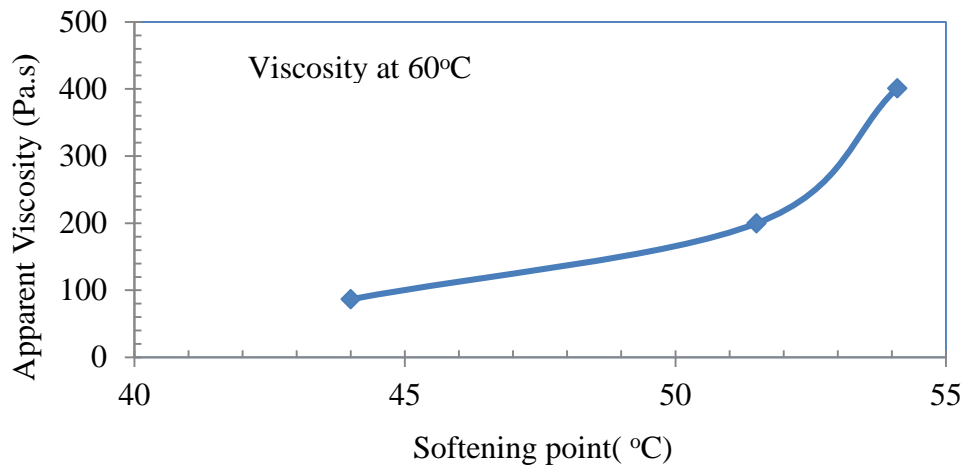

Figure 42: Apparent Viscosity Vs Softening point

## CHAPTER 5: CONCLUSION AND RECOMMENDATION

The aim of this research was to develop a temperature zone map for Ethiopia, based on performance grade asphalt grading system and assessing the rheological properties of locally available asphalt binders, using Dynamic Shear Rheometer and Rotational viscometer. The laboratory experimental results indicate that, it is difficult to find an absolute equivalency between penetration grade and PG grading system. Therefore, conclusions are derived from MSCR test results.

Note that all the samples of asphalt binders are imported from United Arab Emirate and conclusions are only based on the test result of those asphalt binders.

### 5.1 Conclusions

The PG-Map divided Ethiopian Temperature zone into five main PG-grading counties and except the few mountainous and plateau highlands (PG 52-YY), most of Ethiopian areas are dominated by PG 58-YY and PG 64-YY performance grade for standard traffic load. However, low lands areas; such as Afar, Gambela and BenishanguilGumuz show extreme high environmental and pavement temperature. The solution provided by Ethiopian Road Works Corporation, for road construction and rehabilitation in these regions, was to utilize penetration grade 40/50 for its high stiffness and performance.

At the beginning of this research it was expected that penetration grade 40/50 can met the minimum criteria of AASHTO M-320 at 70°C. Nevertheless, according to the PG determination and MSCR test, it failed to meet the criteria and graded as PG64-YY. The non-recoverable compliance ( $J_{nr} \approx 2 \text{kPa}^{-1}$ ) at 64°C indicates that penetration grade 40/50 can be used for most of the South-East and South-West regions of Ethiopia, with a Heavy traffic designation (PG64H-YY). Hence, ERWC should reconsider the asphalt binder that it is using for “Adama-Awash-Mille” asphalt overlay project since it is the main corridor for import-export trade and located near to PG 76-10 temperature zone.

But for expressways constructed in the central part of the country where pavement temperature is between 52°C-58°C, it can perform satisfactorily up to Very Heavy traffic designation with  $J_{nr} = 0.78 \text{kPa}^{-1}$  by taking fatigue crack into account.

Future road construction in Afar region especially eastern part (PG 76-10); require a high quality crude oil or a modified asphalt binder even for a lower standard asphalt concrete pavement.

The other grades (80/100 and 60/70) are graded as PG 58S-YY and PG 64S-YY. Based on environmental temperature only, those binders can perform well. But 60/70 pen-grade's  $J_{nr}$  at 64°C is very close to 4 kPa<sup>-1</sup>, indicating the risk for using the asphalt binder for potentially developing areas with high traffic loads expectations, e.g. Metahara.

Eventually, main trade center cities such as Adama, Hawassa and Mekele are serving or expected to serve high traffic volume and loading. Nevertheless, binders  $J_{nr}$  values indicating that the pavements can only withstand standard traffic load (<10 million ESAL's) with more than 70km/hr speed.

## 5.2 Recommendation

- The study showed that there are some locations with highest pavement temperature more than 76°C. Therefore, economical binder modifiers; such as crumb rubber can be suggested in different proportion to increase the pavement performance. (thesis research by Girma Demke on crumb rubber)
- Asphalt Binder purchasing should consider the actual stiffness difference between asphalt binders rather than penetration values. Therefore, Ethiopian Road Authority must consider its asphalt and mix-design specifications.
- This research PG-map development is based on standard traffic load. So using the map as a guideline, the mix-designer can adjust the asphalt selection process with the traffic load and functional class of the road.

### 5.3 Future Study

So far minimum effort is done to implement and introduce SHRP Superior Performance Pavement mix-design procedure in Ethiopia. Mapping the temperature zone and finding the equivalent grade for currently functioning grading system is only one of the three programs in the agency strategic work. Therefore, related researches can be conducted on:

- A comparative study of Superpave and Marshall mix-design performance.
- Develop temperature conversion algorithm for Ethiopia.
- Effect temperature on Air void and Marshal Mix procedure.

Eventually, this research “Mapping temperature zone” can be also improve to a software which require a road alignment such as latitude, elevation and air temperature as an input; and provide pavement temperature with a certain reliability degree.

## REFERENCES

1. A. ONGEL, J. H. 2004. Analysis of 30 Years of Pavement Temperatures using the Enhanced Integrated Climate Model (EICM). CALIFORNIA, USA: CALIFORNIA DEPARTMENT OF TRANSPORTATION.
2. A. PECCERILLO, C. DONATI, A.P. SANTO, ORLANDO, A., G. YIRGU & AYALEW, D. 2007. Petrogenesis of silicic peralkaline rocks in the Ethiopian rift: Geochemical evidence and volcanological implications. *Journal of African Earth Sciences*, 48, 161–173.
3. AGUCHI, T. K. 1984. VOLCANIC ROCKS IN THE SAMBURU HILLS, NORTHERN KENYA. *African Study Monographs*, African Study Monographs,.
4. ALANI, H. M. H., ALBAYATI, A. H. & ABBAS, A. S. 2010. THE TRANSITION TO A PG GRADING SYSTEM FOR ASPHALT CEMENT IN IRAQ. *Journal of Engineering*, Volume 16.
5. ANDERSON, D. A., CHRISTENSEN, D. W., BAHIA, H. U., DONGRE, R., SHARMA, M. G. & ANTLE, C. E. 1994. Physical Characterization. *Binder Characterization and Evaluation*. USA, DC: Strategic Highway Research Program.
6. ANDERSON, R. M. 2011. Understanding the MSCR Test and its Use in the PG Asphalt Binder Specification. Asphalt Institute.
7. ASI, I. 2007. Performance evaluation of SUPERPAVE and Marshall asphalt mix designs to suite Jordan climatic and traffic conditions. *Construction and Building Materials* 21, 1732-1740.
8. ASPHALT-INSTITUTE 2003. Performance Graded Asphalt specifications and Testing. *Superpave Series No.1*. USA: Asphalt institute.
9. ASPHALT-INSTITUTE 2007. The Asphalt Handbook. USA: Asphalt institute.
10. ASPHALT-INSTITUTE 2008. Asphalt Binder Testing. *Technician's Manual for specification Testing of Asphalt Binder*. USA.
11. BOB HORAN 2003. Performance Graded Binder Testing, Specification and Grade Selection. *Superpave for Low Volume Roads*. USA.
12. CRAMER, R. B. L. S. B. 1999. Superpave Binder Implementation—Oregon DOT. Corvallis, Oregon: Oregon State University.
13. DOLZYCKI, K. B. A. B. 2014. The relationships between asphalt mix rutting resistance and MSCR test results. *Design, Analysis, and Asphalt Material Characterization for Road and Airfield Pavements G*, pp:203-209.
14. DRUTA, C. 2006. A MICROMECHANICAL APPROACH FOR PREDICTING THE COMPLEX SHEAR MODULUS AND ACCUMULATED SHEAR STRAIN OF ASPHALT MIXTURES FROM BINDER AND MASTICS. PH.D. experimental, Louisiana State University.
15. ENGIDASEW, T. A. 2013. *ENGINEERING GEOLOGICAL CHARACTERIZATION OF VOLCANIC ROCKS OF ETHIOPIAN AND SARDINIAN HIGHLANDS TO BE USED AS CONSTRUCTION MATERIALS*. PhD experimental, University of Cagliari.
16. FHWA 1994. Superpave Fundamentals. USA: U.S. Department of Transportation.
17. HITCON-ENGINEERING 2016. Detail condition survey Report for Paved Roads *Lot-1*. Ethiopia: Ethiopian Road Authority.
18. HUBER, G. A. 1994. Weather Database for the SUPERPAVE Mix Design System. USA: Strategic Highway Research Program.

19. J. C. PETERSEN, R. E. R., J. F. BRANTHAVER, P. M. HARNSBERGER, J. J. D., S. S. KIM, D. A. ANDERSON, D. W. C., H. U. BAHIA, R. D., C. E. ANTLE, M. G. SHARMA & J. W. BUTTON, C. J. G. 1994. Binder Characterization and Evaluation: Test Methods. *Binder Characterization and Evaluation*. USA, DC: SHRP.
20. JOHN READ, D. W. 2003. *The Shell Bitumen Handbook*, London, thomas Telford publishing. KABIR, M. S. 2013. Louisiana's Experience with Multiple Stress Creep Recovery (MSCR) Test. *Louisiana Transportation Conference*. Baton Rouge, Louisiana: Louisiana Transportation Research Center.
21. KSAIBATI, C. Y. A. K. 2002. Assessment of temperature Fluctuation in Asphalt pavement. USA: Univeristy of Wyoming.
22. M. WASEEM MIRZA, ABBAS, Z. & RIZVI, M. A. 2011. Temperature Zoning of Pakistan for Asphalt Mix Design. *Pak. J. Engg. & Appl. Sci.*, Vol. 8, p. 49-60.
23. MEHTA, Y., NOLAN, A., DUBOIS, E., ZORN, S. & BATTEN, E. 2013. Correlation between Multiple Stress Creep Recovery (MSCR) Results and Polymer Modification of Binder. USA, New York,: Rowan University.
24. MINHOTO, M. J. C., PAIS, J. C. & PEREIRA, P. A. A. 2005. Asphalt Pavement Temperature Prediction. *Road Materials and Pavements Design*, Volume X, pages 1 to 15.
25. PETERSEN, J. C., ROBERTSON, R. E., HARNSBERGER, P. M., BRANTHAVER, J. F., J.J. DUVALL, S. S. K., D.A. ANDERSON, D. W. C. & BAHIA, H. U. 1994. Asphalt Model. *Binder Characterization and Evaluation*. USA: Strategic Highwaw Research Program.
26. PROWELL, B. D. 1999. SELECTION AND EVALUATION OF PERFORMANCE-GRADED ASPHALT BINDERS FOR VIRGINIA. Charlottesville, Virginia: University of Virginia).
27. RADZISZEWSKI, P., KOWALSKI, K. J. & JAN B. KRÓL 2014. Quality assessment of bituminous binders based on the viscoelastic properties: Polish experience. Volume 20.
28. ROBERTS, F. L., KANDHAL, P. S., BROWN, E. R. & LEE, D., KENNEDY, T.W. 1996. *Hot Mix Asphalt Materials, Mixture Design and Construction*, Lanham, Maryland, NAPA Research and Education Foundation.
29. WALLE, H., ZEWEDE, S. & HELDAL, T. 2000. Building stone of central and southern Ethiopia:deposits and resource potential. 175-182.
30. WORLD-BANK 2008. Project performance assessment report. *Road Sector Development Program Support Project*.
31. ZANIEWSKI, J. P. & PUMPHREY, M. E. 2004. Evaluation of Performance Graded Asphalt Binder Equipment and Testing Protocol. Morgantown, West Virginia: Asphalt Technology Program.

## APPENDIX A: Amplitude Sweep Test Results

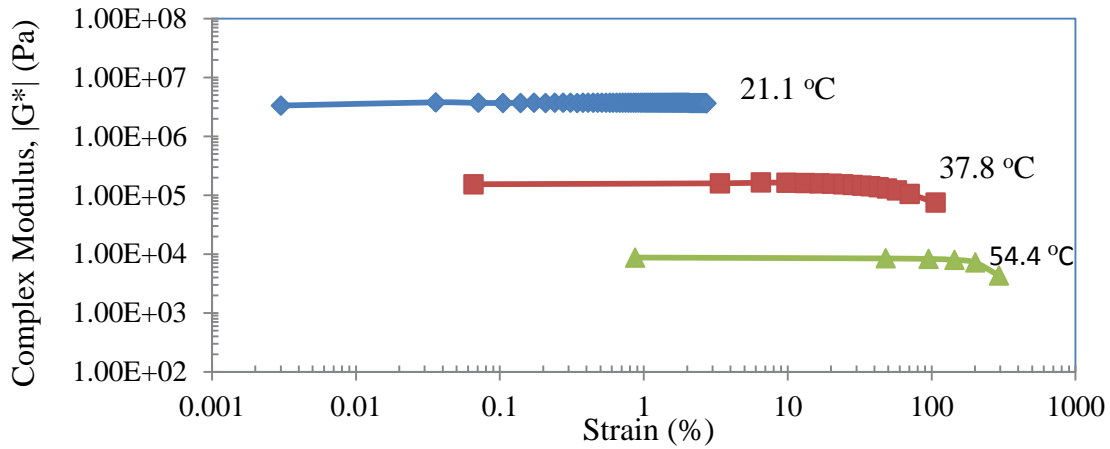

a: 40/50 (original binder)

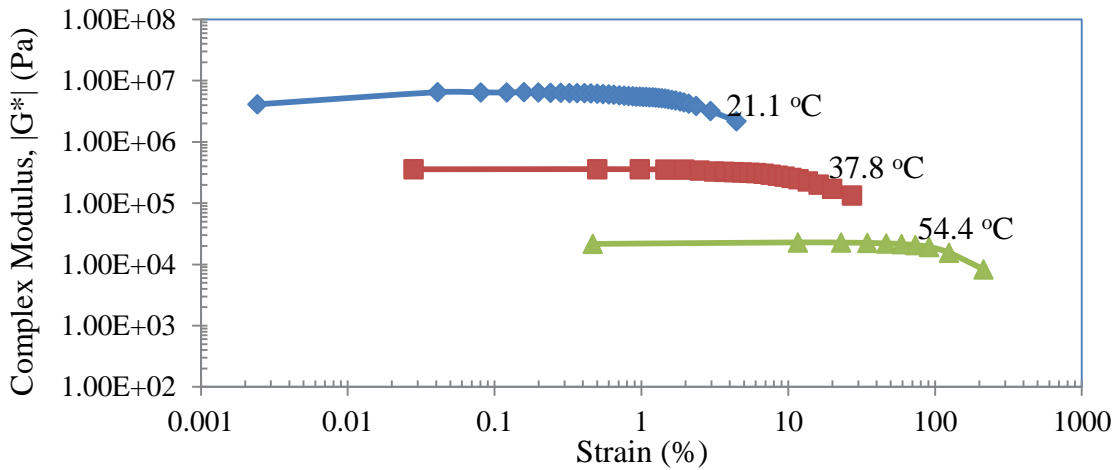

b: 40/50 (aged binder)

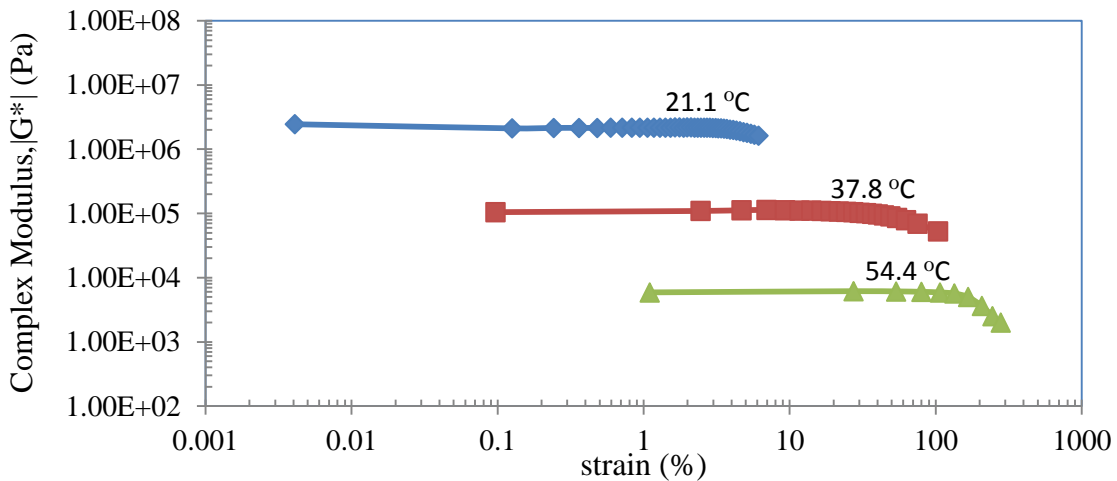

c: 60/70 (original binder)

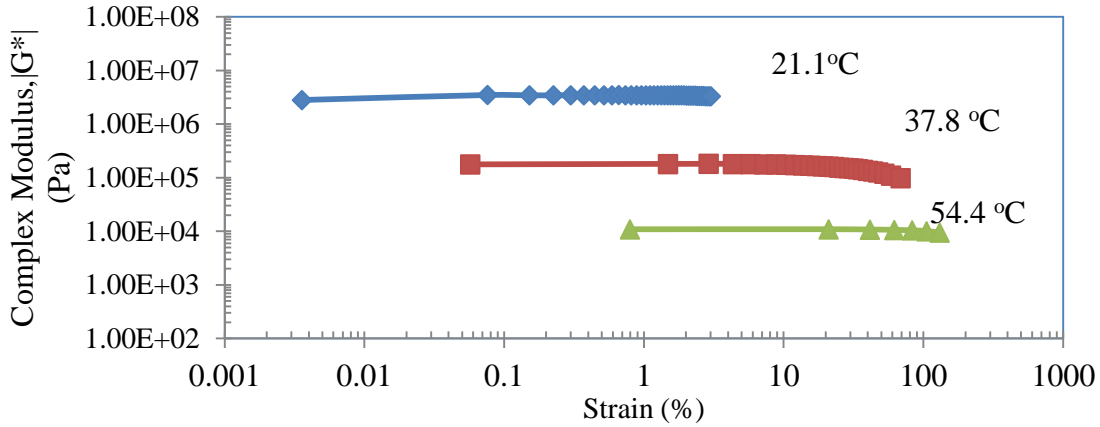

d: 60/70 ( aged binder)

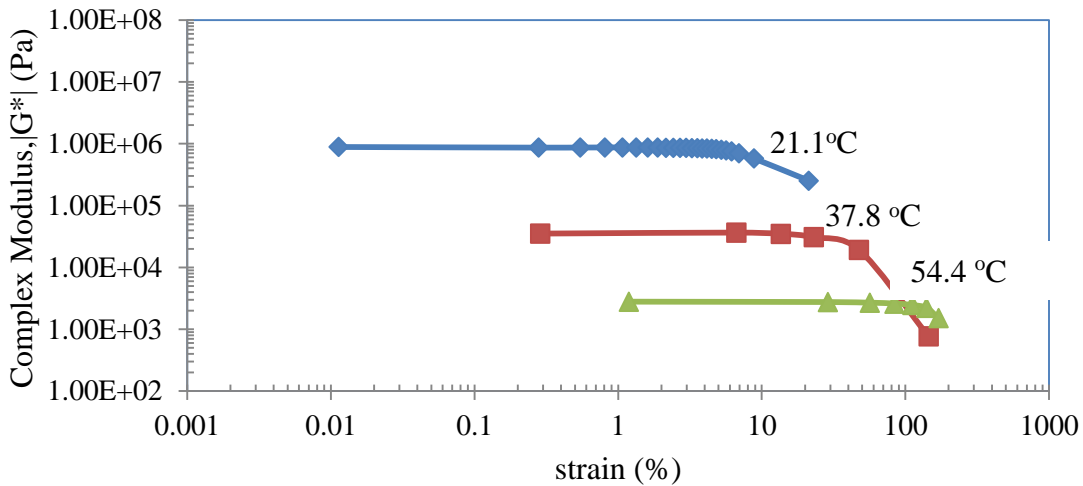

e: 80/100 (original binder)

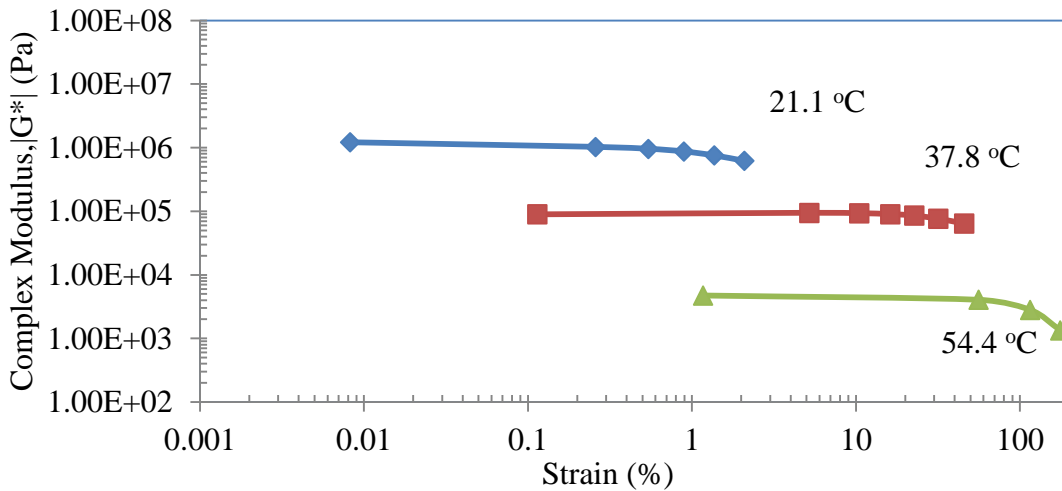

f: 80/100 (aged binder)

## APPENDIX B: Frequency Sweep Test Results

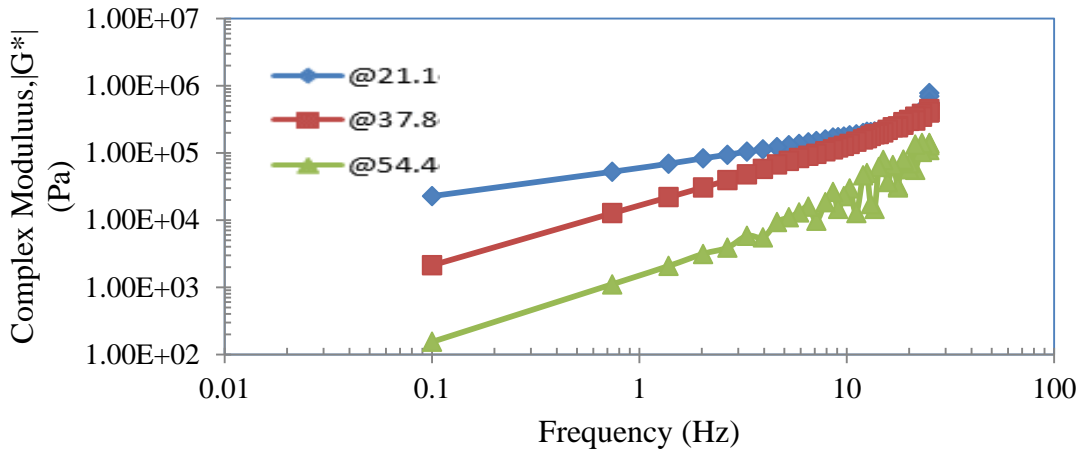

a: 80/100 (original binder)

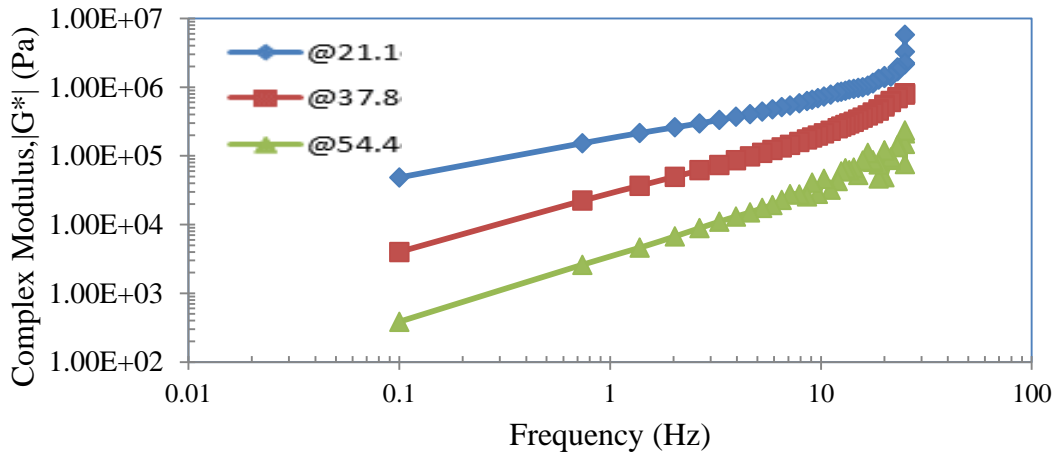

b: 80/100 (aged binder)

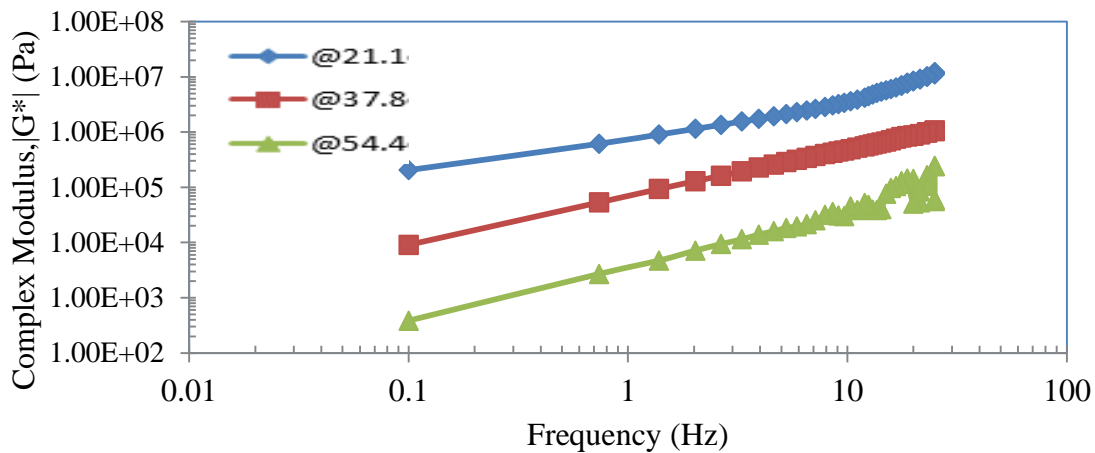

c: 60/70 (original binder)

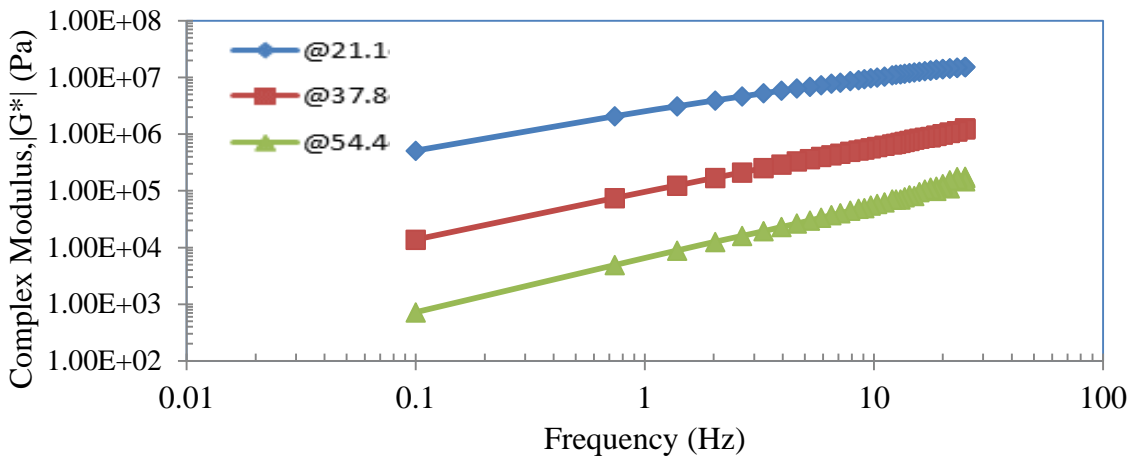

d: 60/70 (aged binder)

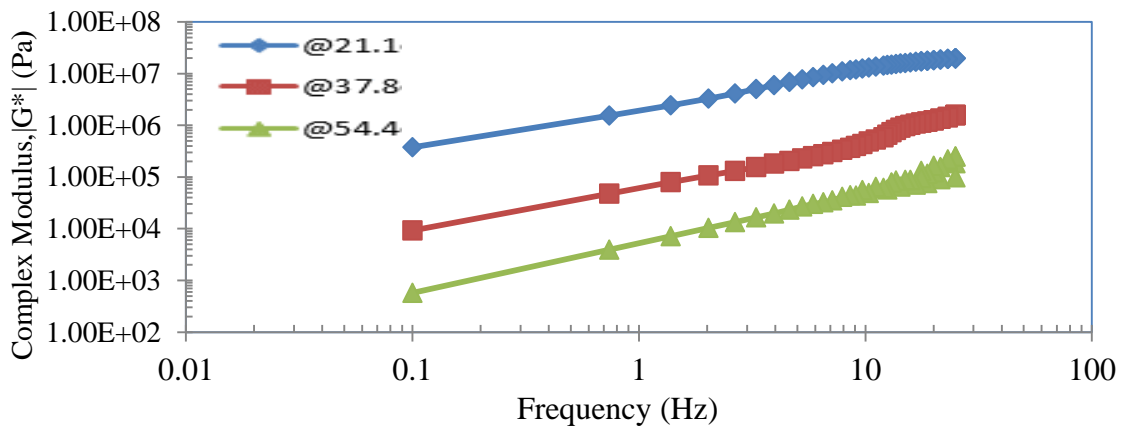

e: 40/50 (original binder)

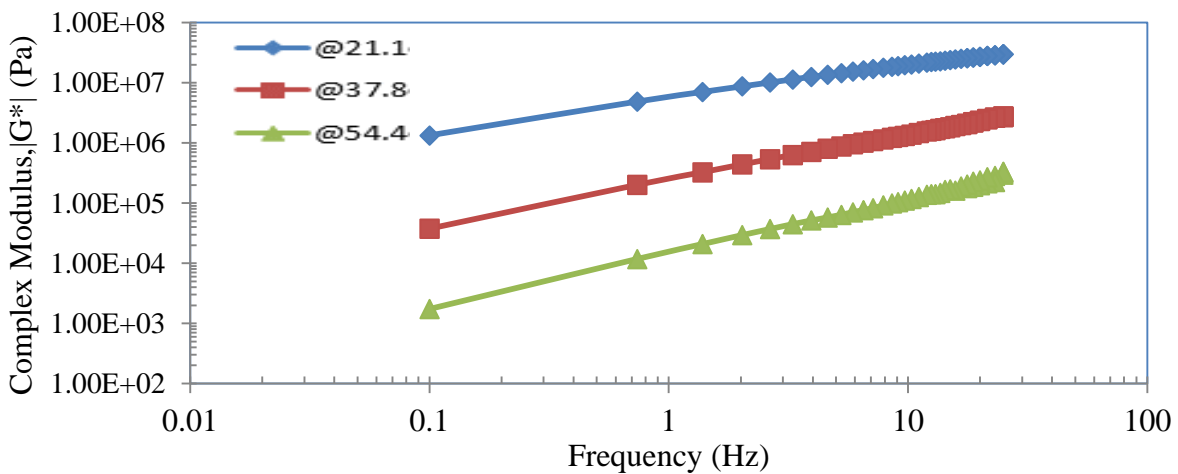

f: 40/50 (aged binder)

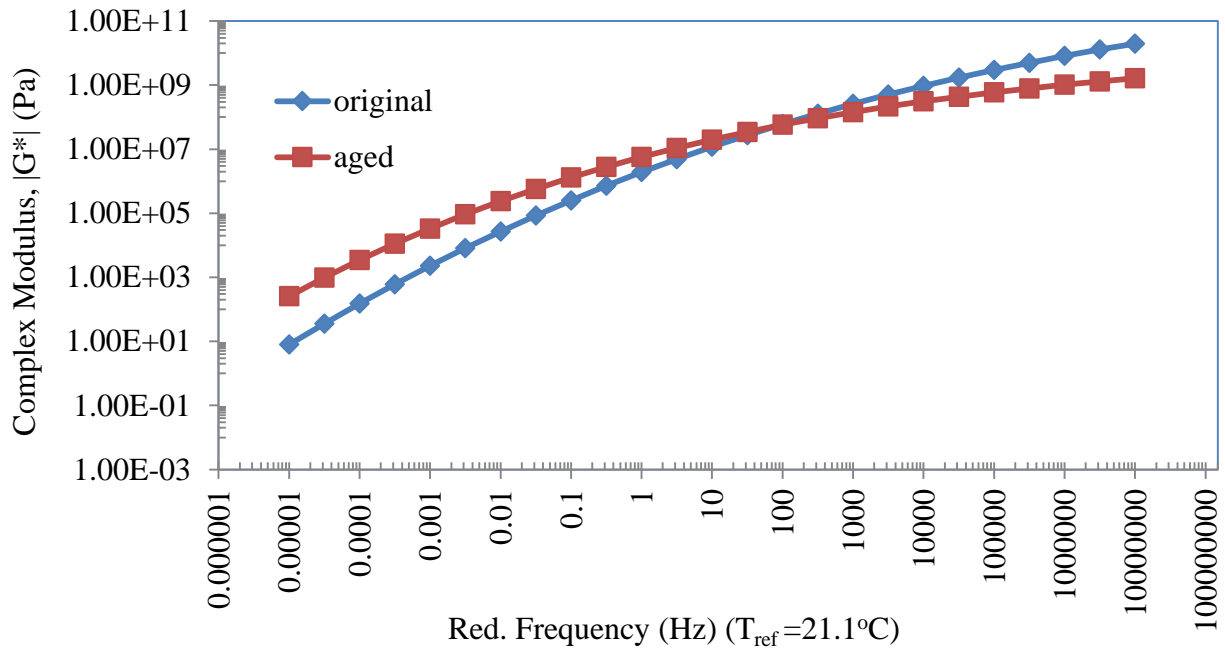
**APPENDIX C: Aging Effect on Master Curve**

a. 40/50 C

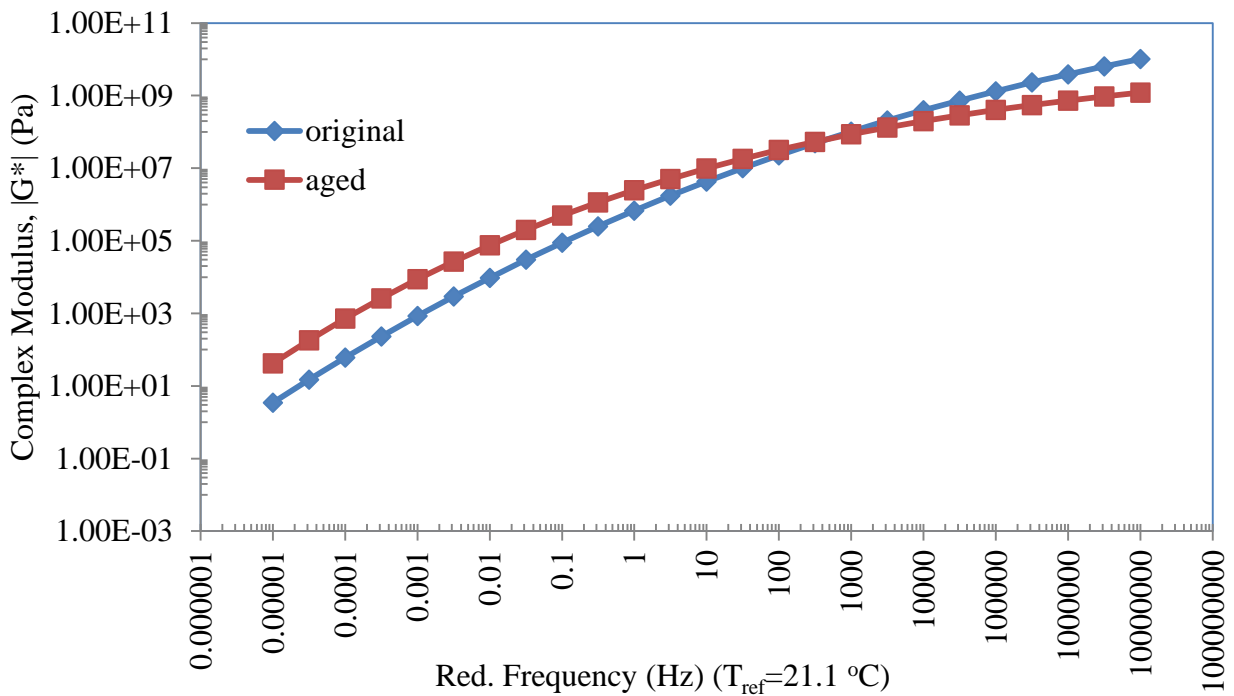

b. 60/70 E

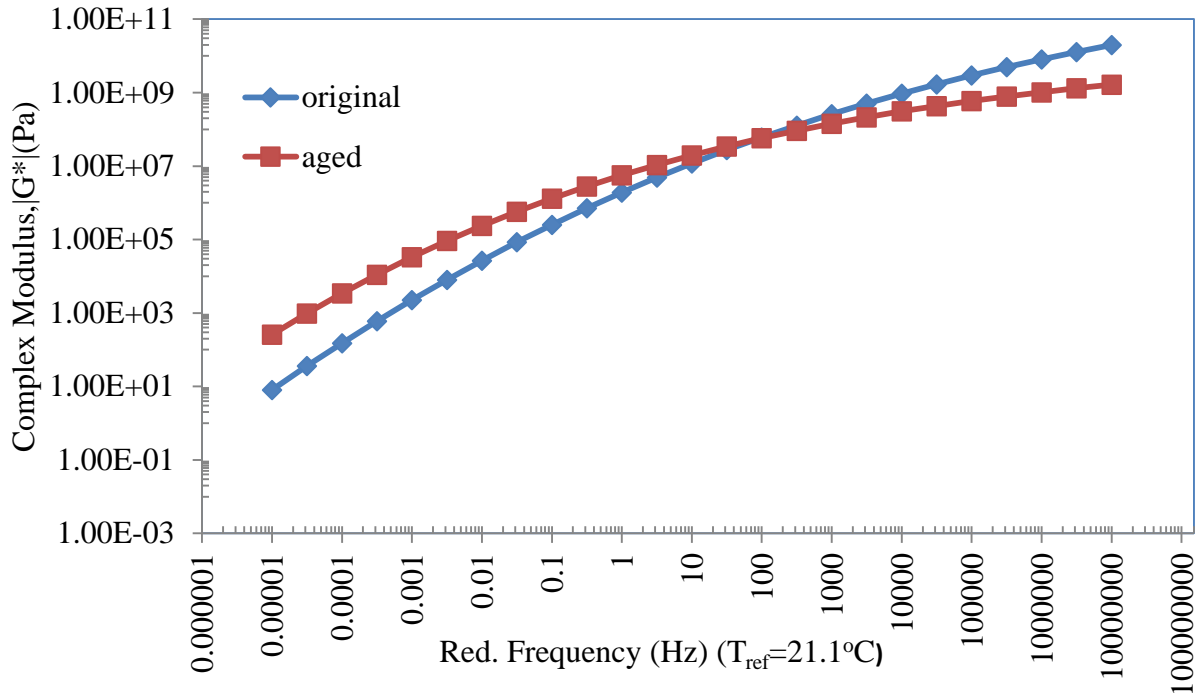

c. 60/70 A

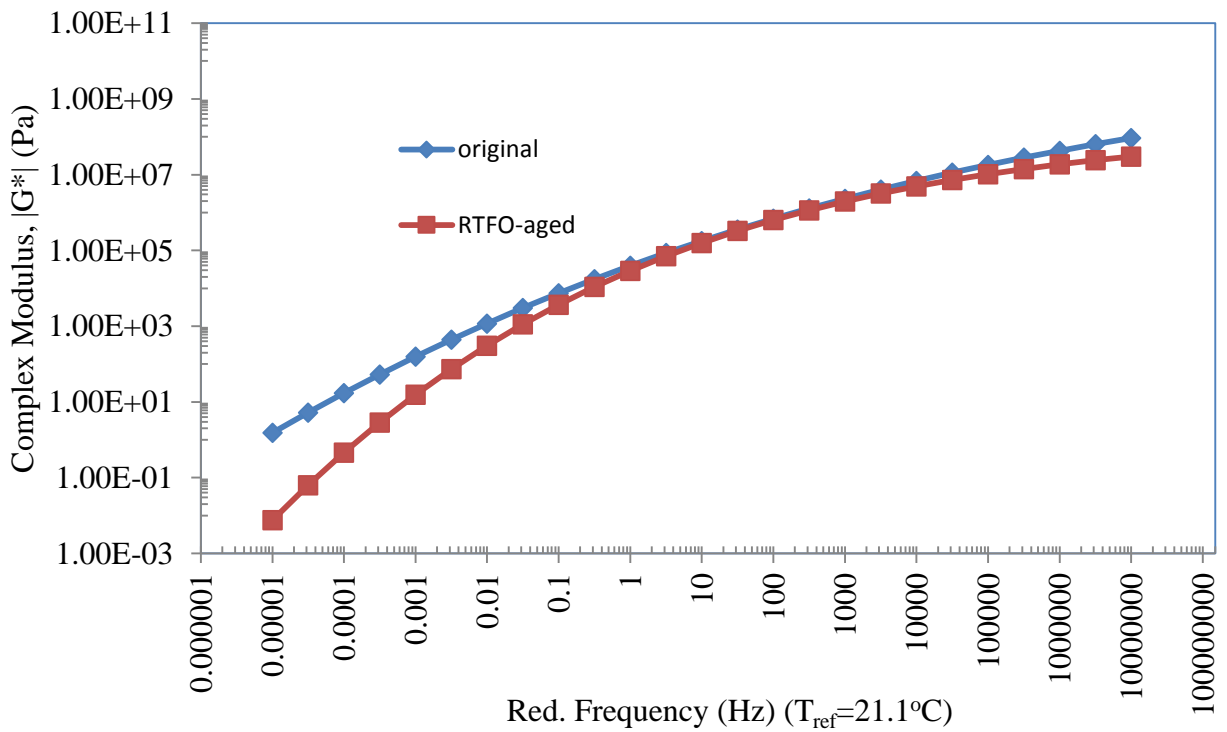

d. 80/100

### APPENDIX D: Aging effect on Phase Angle

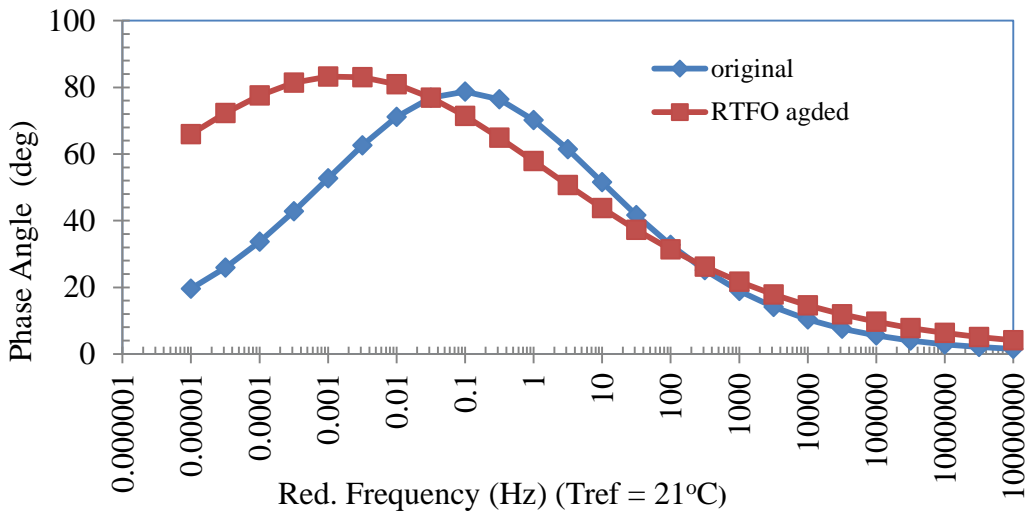

a. 40/50 E

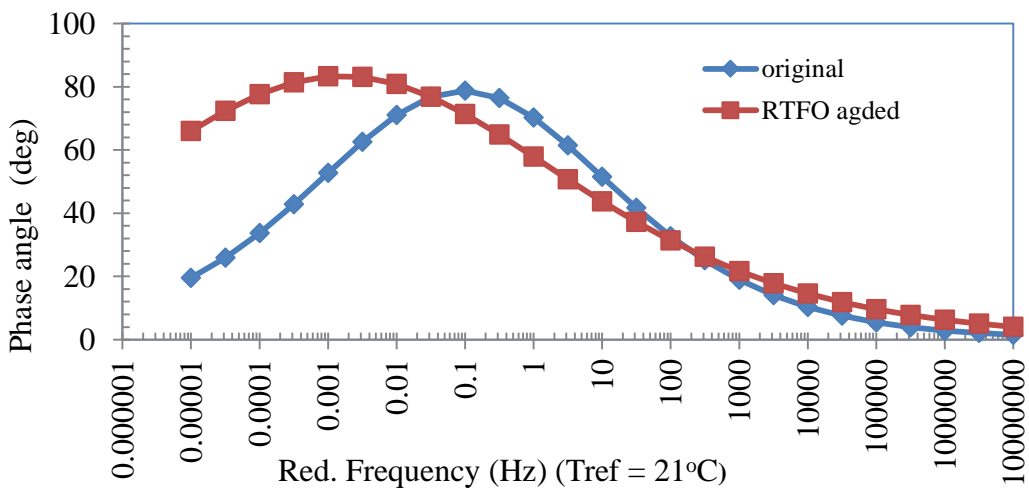

b. 40/50 C

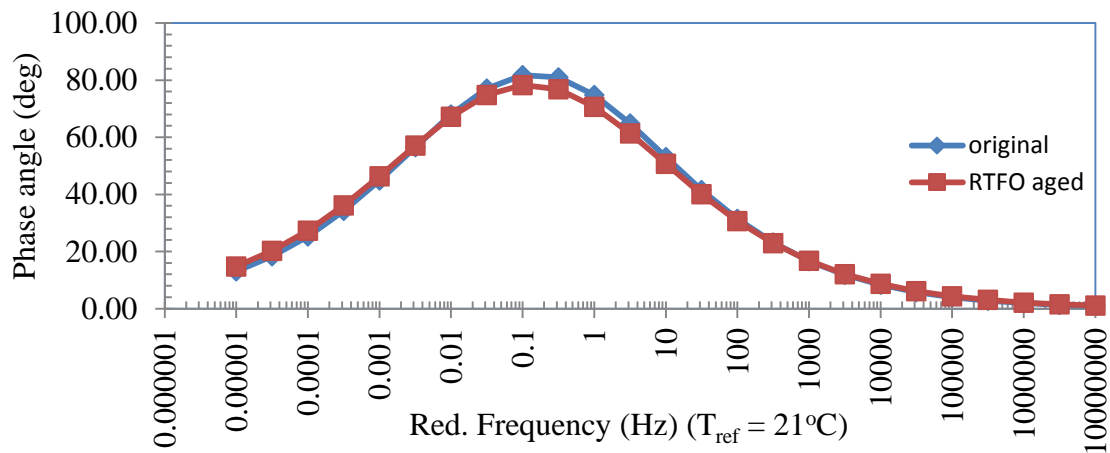

c. 60/70 A

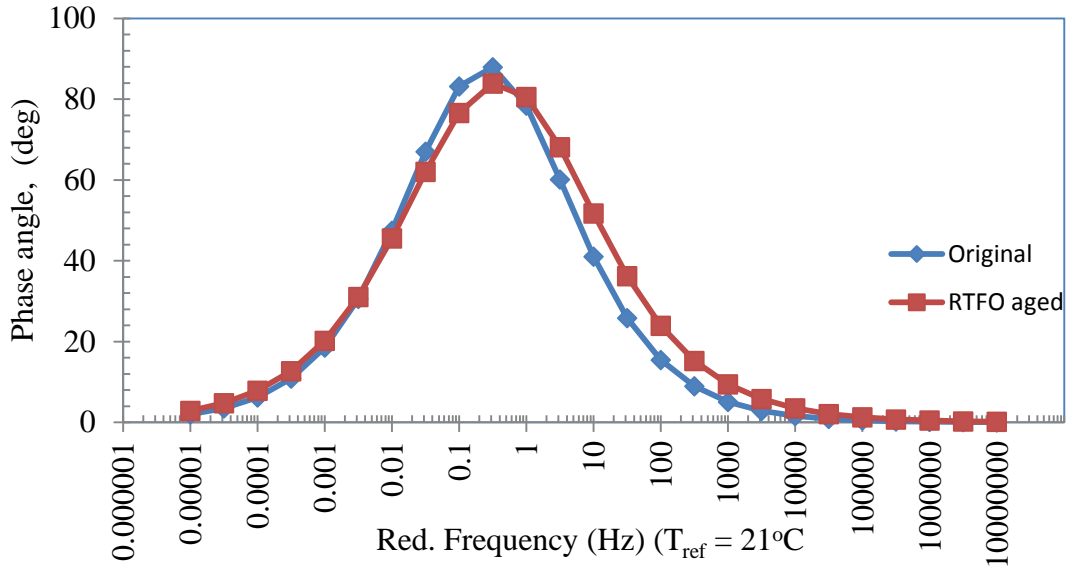

d. 80/100

## APPENDIX E: Black Space Diagram

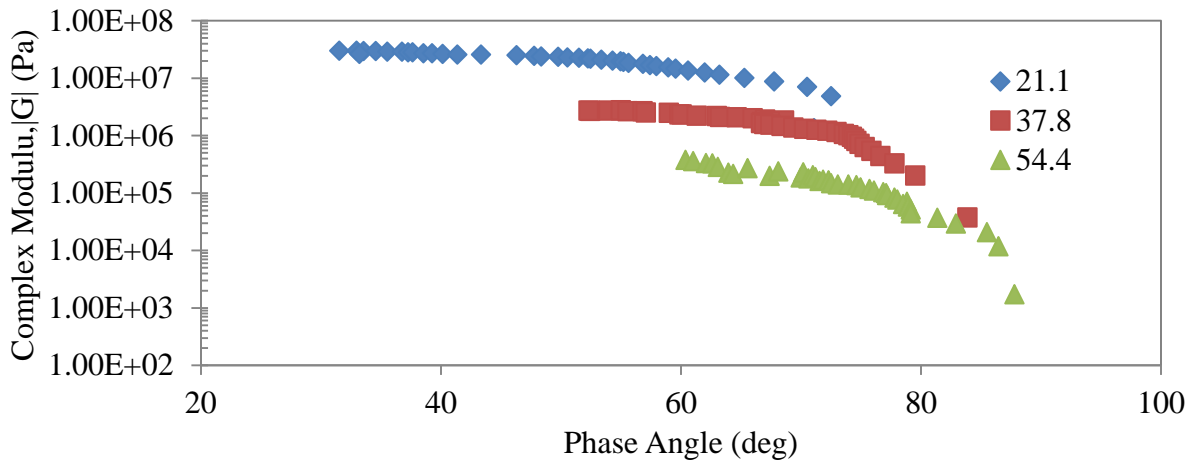

a. 40/50 RTFO-aged

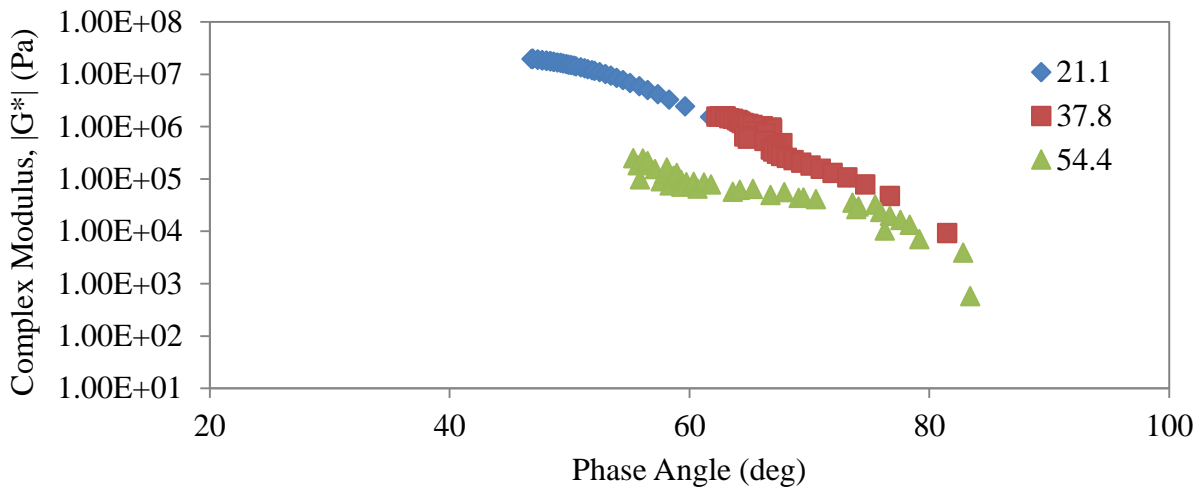

b. 40/50 Original

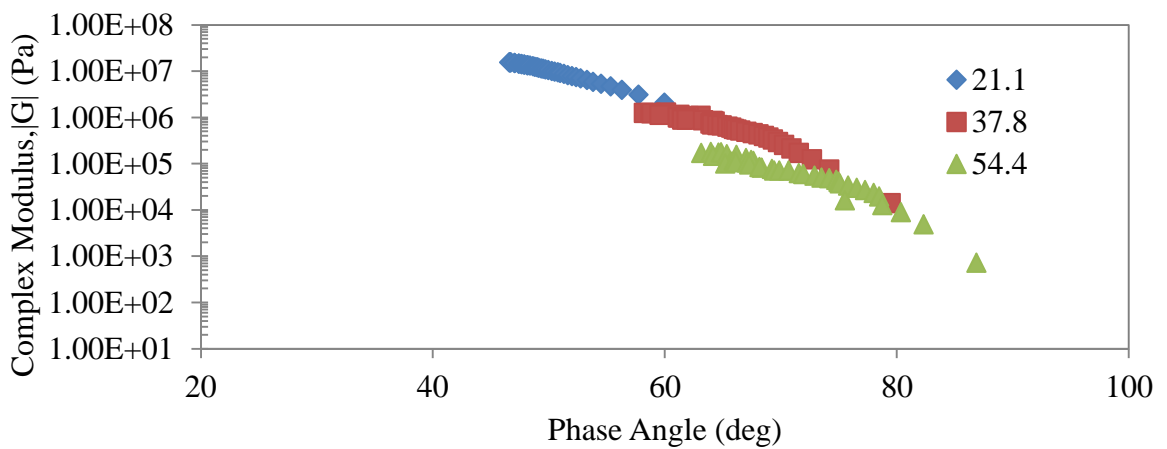

c. 60-70 RTFO-aged

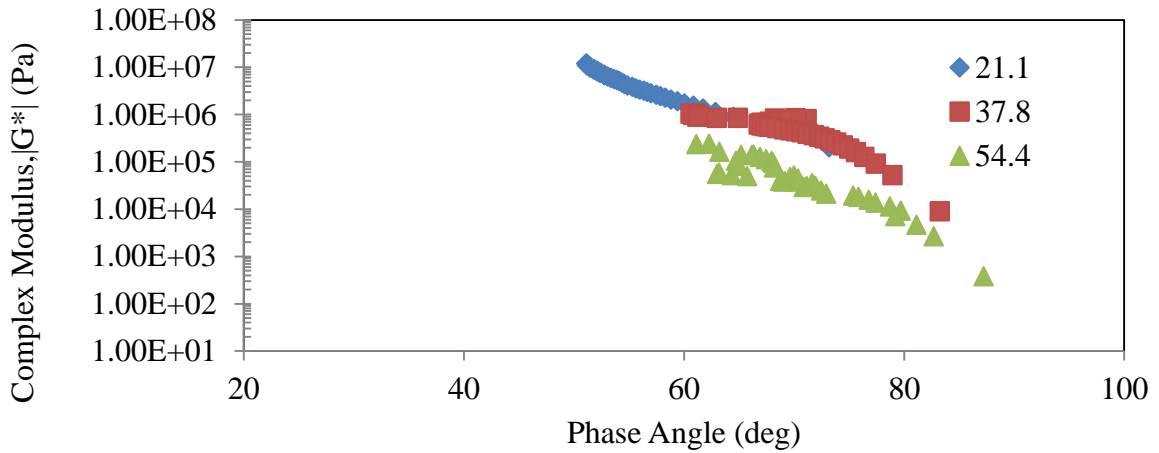

d. 60-70 Original

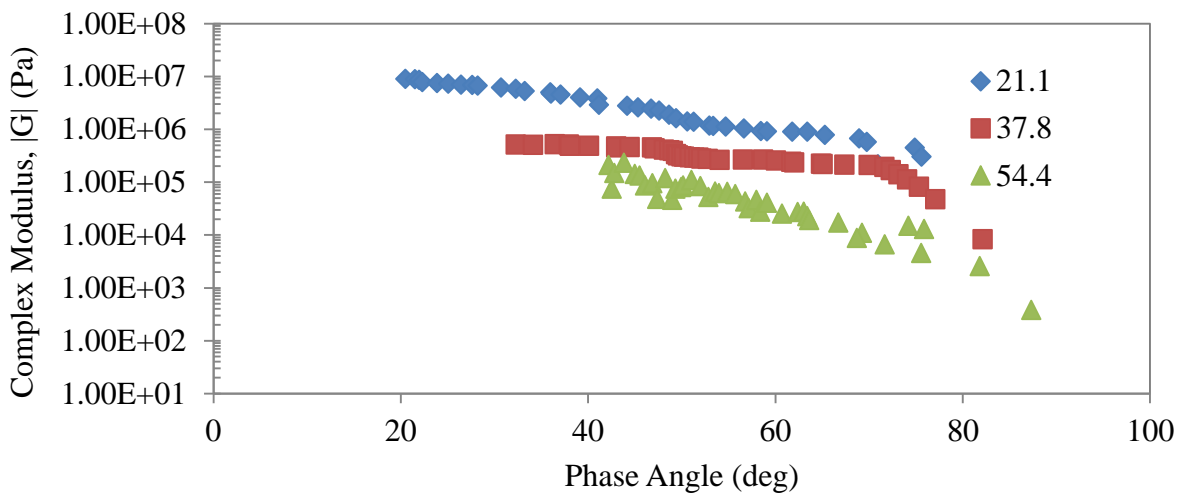

e. 80/100 RTFO-aged

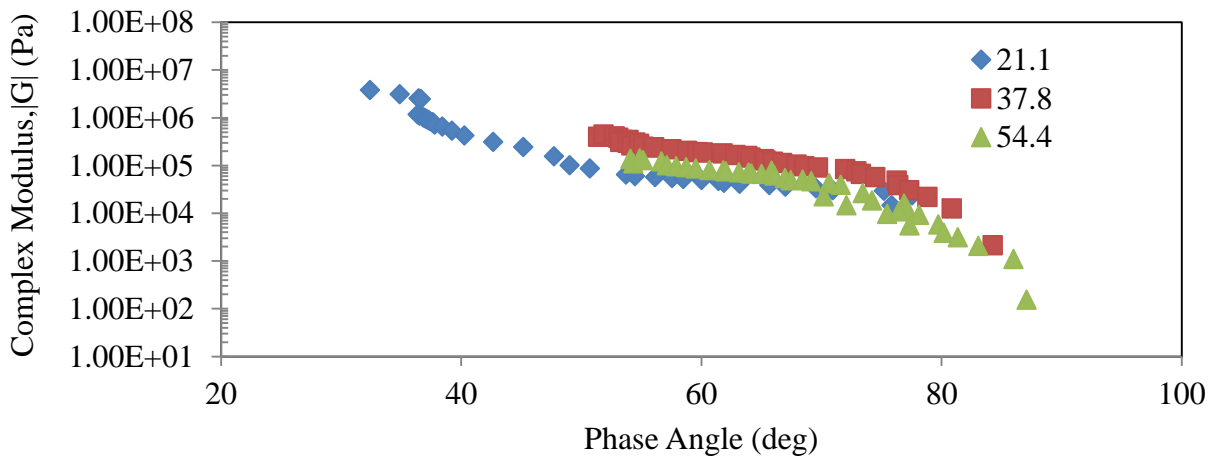

f. 80/100 Original

## APPENDIX F: Performance Grade Test Results

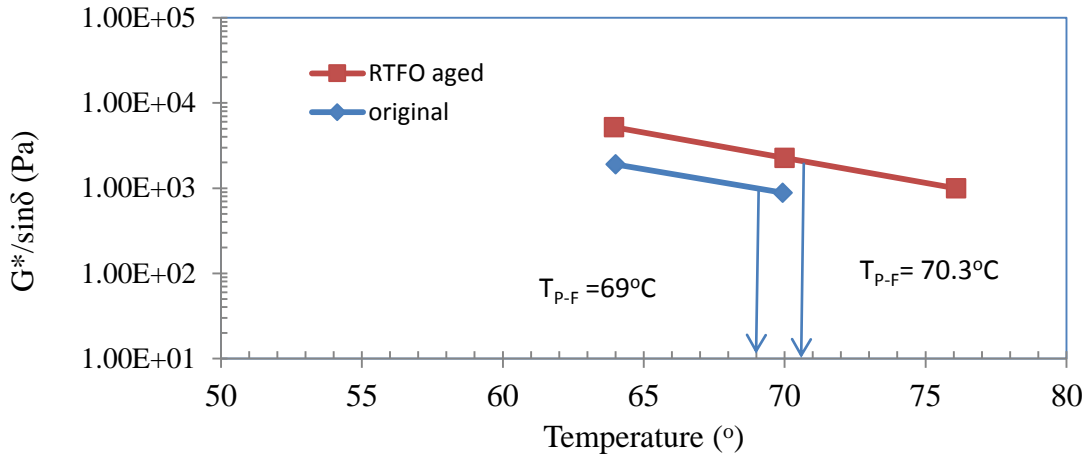

a: 40/50 (ECWC)

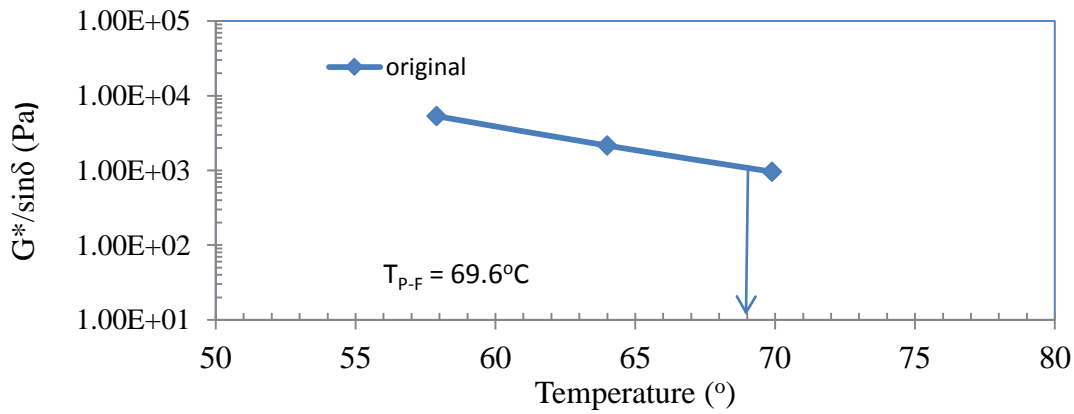

b: 40/50 (CCCC)

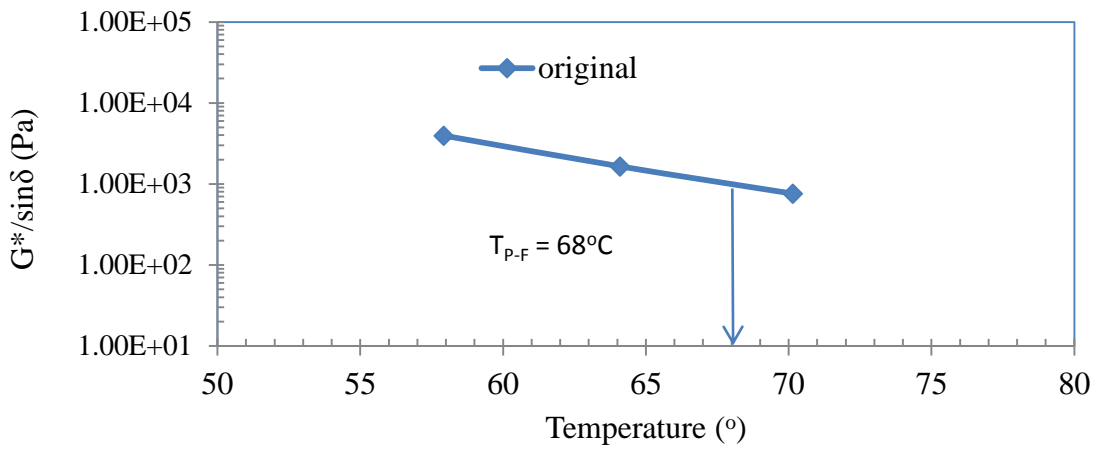

c: 60/70 (ECWC)

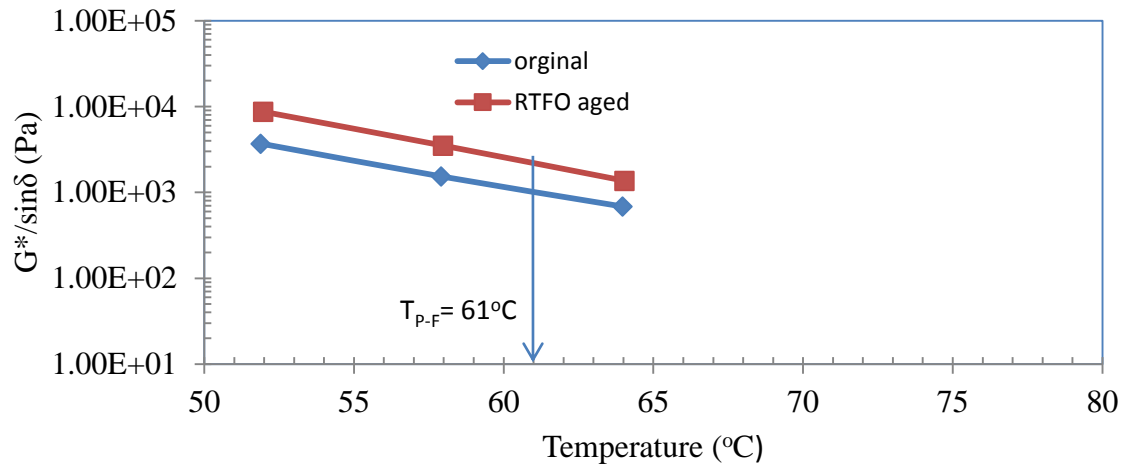

d: 80/100 (ERWC)

## APPENDIX G: MSCR-Test Results in Graph

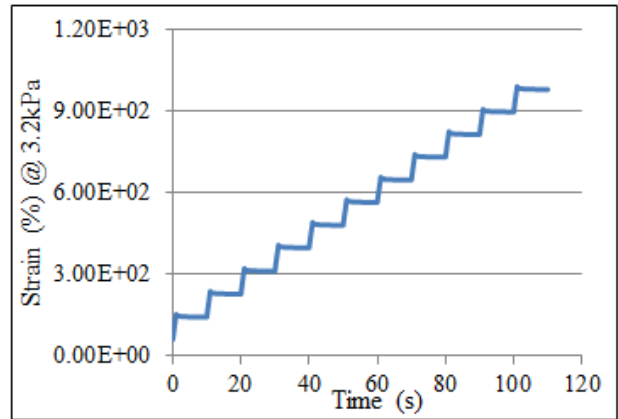
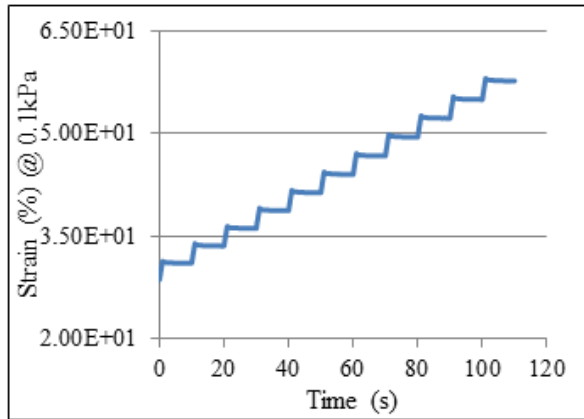

a: 40/50 @ 52 °C

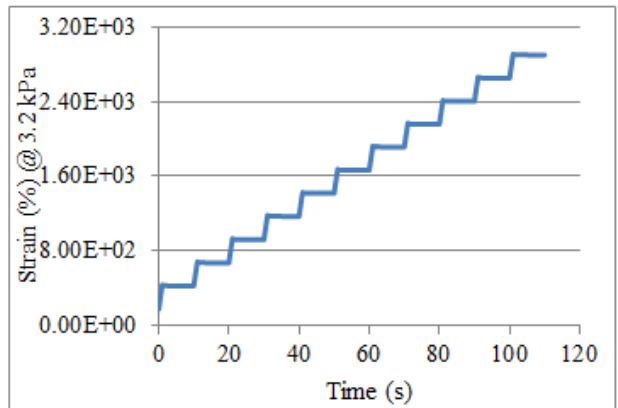
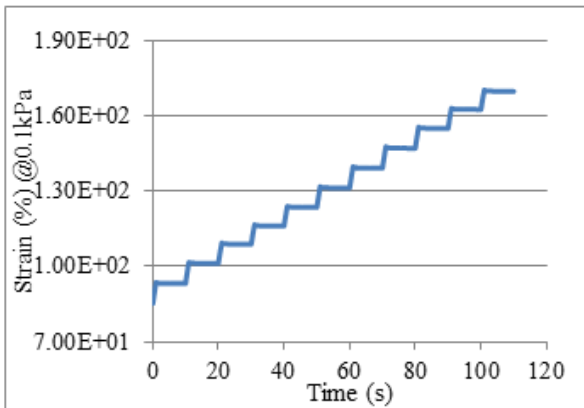

b: 40/50 @ 58°C

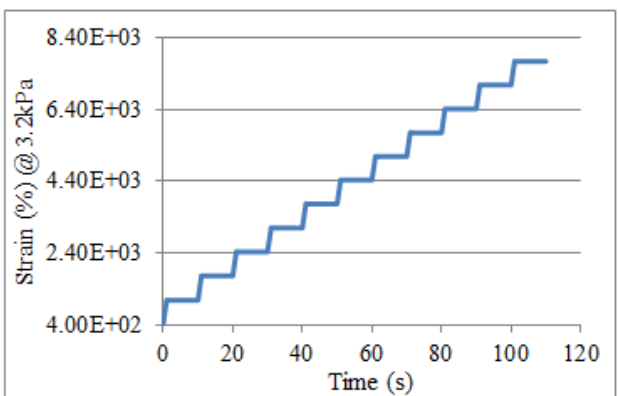
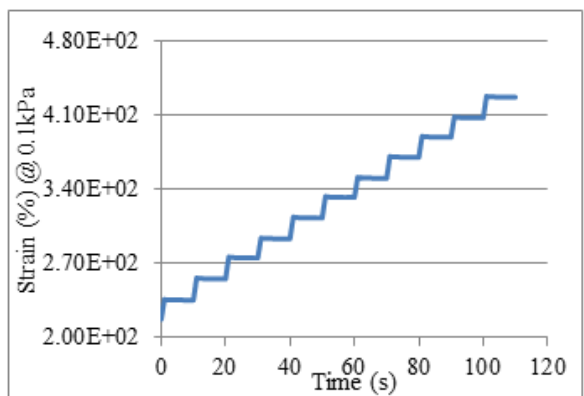

c: 40/50 @ 64°C

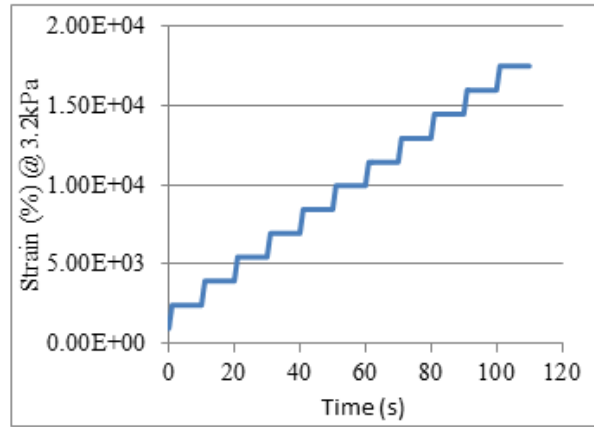
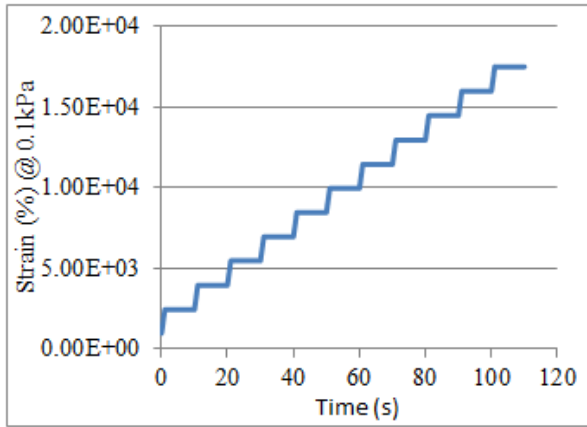

d: 40/50 @ 70°C

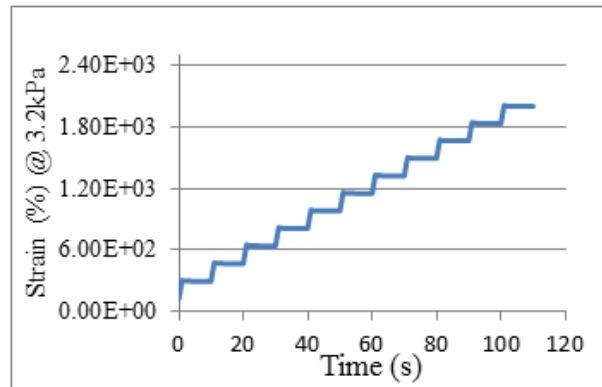
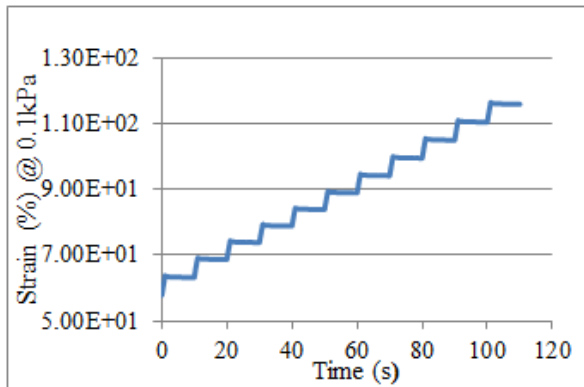

e: 60/70 @ 52°C

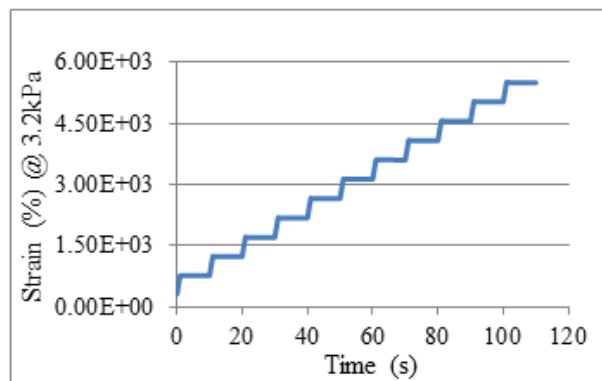
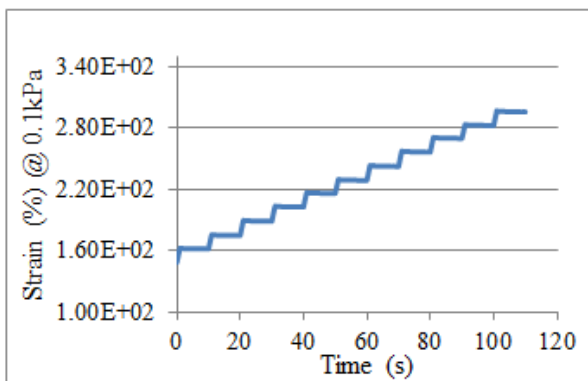

f: 60/70 @ 58°C

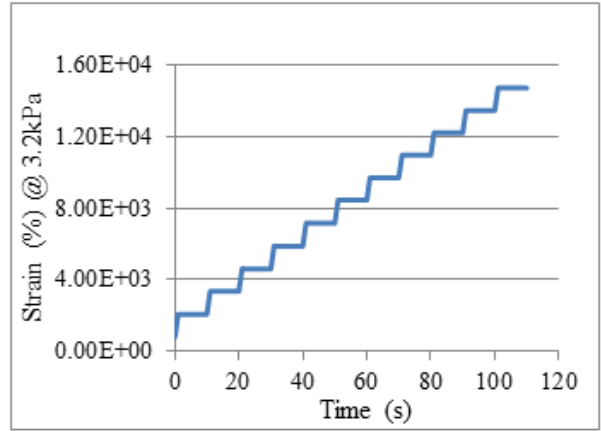
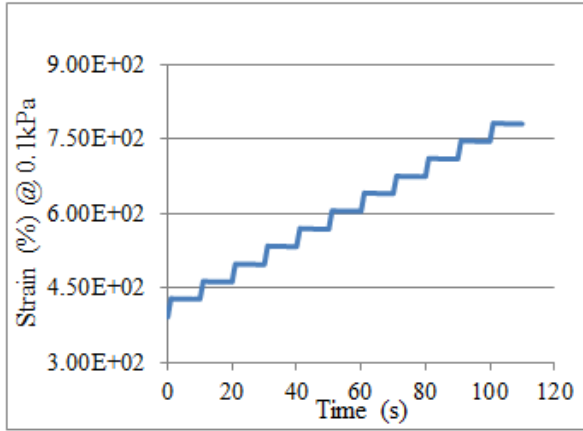

g: 60/70 @ 64°C

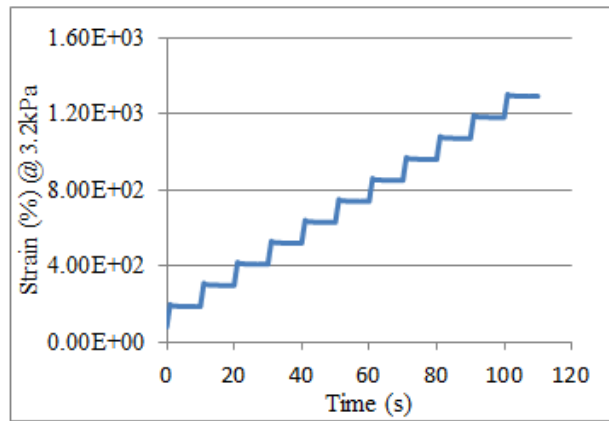
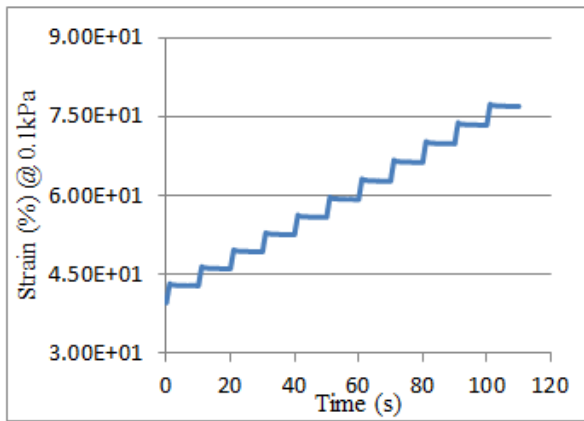

h: 80/100 @ 46°C

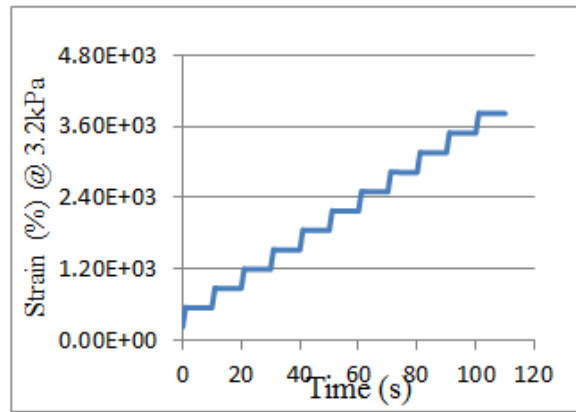
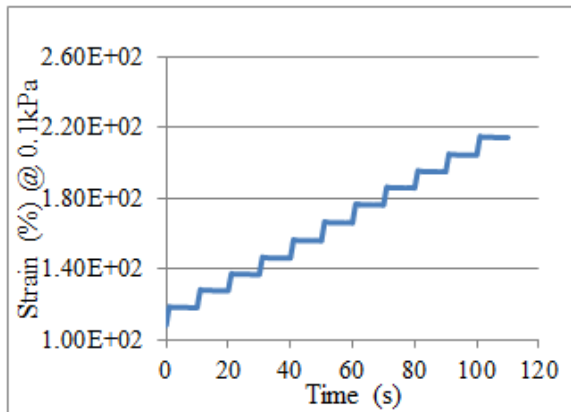

i: 80/100 @ 52°C

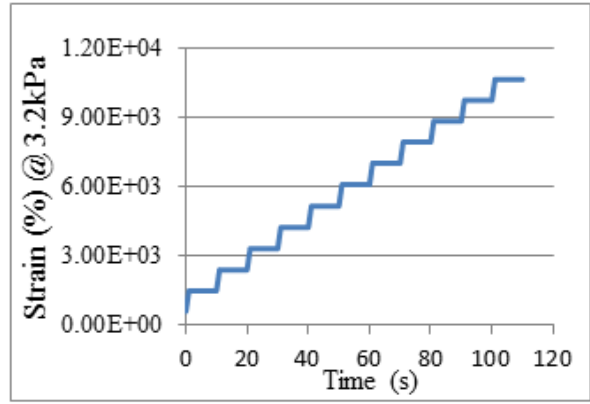
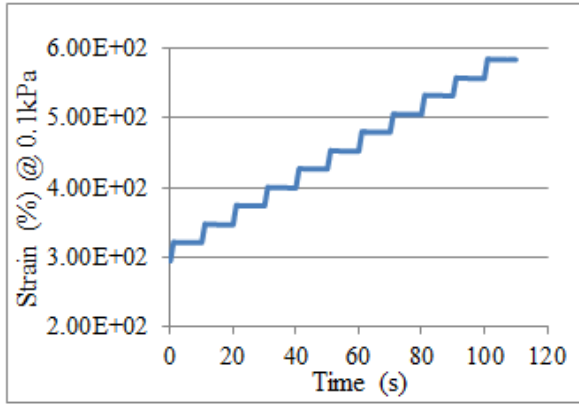

j: 80/100 @ 58°C