



SEEK WISDOM, ELEVATE YOUR INTELLECT AND SERVE HUMANITY !



ADDIS ABABA UNIVERSITY
ADDIS ABABA INSTITUTE OF TECHNOLOGY
SCHOOL OF MECHANICAL AND INDUSTRIAL
ENGINEERING
MASTER OF SCIENCE IN MECHANICAL
ENGINEERING
(THERMAL ENGINEERING)

**Experimental Investigation of Concentrated Solar Bread
Baking Oven Integrated with Thermal Energy Storage**

A Thesis Submitted to the School of Graduate Studies of Addis Ababa
University in Partial Fulfillment of the Requirements for the Degree of
Master of Science in Thermal Engineering

BY: YODIT SHIMELS

Advisor: Kamil Dino Adem (PhD)

January, 2025
Addis Ababa, Ethiopia

Addis Ababa University
Addis Ababa Institute of Technology
School of Mechanical and Industrial Engineering
Approval of MSc. Thesis proposal

Submitted by:

Yodit Shimels Getachew

Student name

Signature

Date

Recommended by:

Dr. Kamil D. Adem

Advisor

Signature

Date

Dr. Habtamu Tekubet

External Examiner

Signature

Date

Dr Wondwossen Bogale

Internal Examiner

Signature

Date

Approved by:

Dr. Habtamu Tekubet

**Research Group Head of
Thermal Stream**

Signature

Date

Endorsed by:

Dr. Abdulkadir Aman H.

Dean School of Mechanical

Signature

Date

And Industrial Engineering

Dr. Shegaw Ahemed

Associate Dean for Academic

Signature

Date

Affair

DECLARATION

I hereby declare that this thesis entitled “Experimental Investigation of Concentrated Solar Bread Baking Oven Integrated with Thermal Energy Storage” is my original work. All the research, experiments, data collection, analysis, and writing presented in this thesis have been carried out by me under the guidance and supervision of my advisor Dr Kamil Dino.

I also declare that this work has not been submitted in whole or in part to any other university or institution for the award of any degree or diploma. This thesis has properly credited all of the sources of information and references it used.

Yodit Shimels	_____	_____
Name	Signature	Date

This thesis has been submitted for assessment with the approval of a university advisor.

Kamil Dino Adem (PhD)	_____	_____
Advisor	Signature	Date

ACKNOWLEDGEMENT

Primarily, I would like to mention the highest of my thanks to God for providing me strength, patience, and guidance throughout the accomplishment of this thesis. Along with this, I sincerely thank Saint Mary (Virgin Mary) for her help, blessings, and intercession during my whole way in the educational field.

I owe a debt of gratitude to my advisor, Dr. Kamil Dino, for his unfailing guidance, wise suggestions, and encouragement throughout the designing, experimental work, and writing phases of this thesis.

My thanks go to the workshop staff and AAiT technical workers as well, and I am particularly grateful to Antene and Tadesse for their brilliant support in the making of the experimental setup and their help in overcoming the practical challenges.

I am really thankful and I want to express my deepest thanks to my parents, my sister and her husband, my brother, and my husband for their everlasting love, great patience, and support, which kept me going even in the tough times.

At last, I acknowledge to all the people who have been a part, either directly or indirectly, of this research accomplishment. I have really valued your support, your words of encouragement, and your advice.

ABSTRACT

This research illustrates the innovative design, build, and performance testing of a solar bread oven with a parabolic trough and pebble bed thermal energy storage system. The purpose of developing such a system is to offer a clean cooking solution that can be easily accessible and affordable for the rural communities of Ethiopia, where people still heavily rely on biomass for cooking and there is a shortage of fuel. The oven along with its accompanying thermal storage unit was positioned at the focal line of the parabolic trough to absorb and store solar heat and to provide steady baking temperatures.

Experimental tests were done in open air at the AAiT campus in Addis Ababa. The results indicated that the air temperature in the oven went up to 89–101°C, the bread core temperature was 77–81°C, and the pebble bed temperature climbed to 72.9-90 °C. Each test saw the baking of 20 small bread pieces (90 g each) in total. The overall system thermal efficiency was between 2.6% and 3.5%, whereas the first figure of merit (F_1) fluctuated from 0.08 to 0.107 during no-load testing. The system managed to bake the bread even though solar radiation was highly variable most of the days of the tests. Sensory evaluation made by ten persons also supported that the bread was properly baked inside although the outer part did not get brown as a result of the relatively low radiant heat.

Overall, the study demonstrates that a parabolic trough solar bread-baking oven with pebble-bed thermal storage can function under Ethiopian conditions, providing a clean and fuel free baking option. The results also highlight areas for improvement in insulation, optical efficiency, and heat retention for better performance.

Keyword: - Solar bread baking oven, Parabolic trough collector, Thermal energy storage (TES), Pebble-bed storage, Thermal efficiency, Experimental investigation, Renewable energy.

Table of Contents

ABSTRACT.....	v
ABBERRVIATION AND ACRONYMS	x
CHAPTER ONE INTRODUCTION	1
1.1 Background.....	1
1.2 Statement of the problem	4
1.3 Objective of the Study	4
1.3.1 General Objective	4
1.3.2 Specific Objectives	4
1.4. Significance of the research	5
1.5. Limitations	5
1.6. Organization of the research	5
CHAPTER TWO LITERATURE REVIEW	6
2.1 Introduction to solar energy	6
2.2Traditional Cooking & Baking	7
2.3 Biomass Energy Use and Its Role in Ethiopia's Cooking Sector	8
2.4 Solar Cooking Technologies.....	9
2.4.1Classification of Solar Cookers.....	10
2.4.1.1Direct solar cooker	10
2.4.1.2 Indirect Solar cookers	12
2.5 Thermal Energy Storage (TES) Materials	14
2.5.1 Sensible Heat Energy Storage.....	15
2.5.2. Latent Heat Energy Storage System (LHESS).....	15
2.6 Solar thermal collector	16
2.6.1. Parabolic Trough Solar Collector.....	17
2.7 Thermal Insulation	19
2.8Literature Summary	19
CHAPTER THREE	24
MATERIALS AND METHODS.....	24
3.1 Introduction.....	24

3.2 Materials	24
3.3 Methodology	28
3.3.1 Data collection methods.....	29
3.3.2 Literature survey	29
3.4 System Working Principle	29
3.5 Testing Method	29
CHAPTER FOUR DESIGN OF SOLAR BREAD BAKING OVEN WITH THERMAL ENERGY STORAGE	31
4.1. Description of the overall concept of solar bread baking oven.....	31
4.2. Design Specifications of Solar Bread Baking System	32
4.2.1. Dough Preparation for Baking	33
4.2.2. Impact of Water Content on Baking	33
4.3. Energy Required for Bread Bakery.....	33
4.4. Oven Chamber Design.....	35
4.5. Thermal energy storage design	35
4.6. Parabolic Dish Concentrator Design.....	38
4.7 Manufacturing steps.....	42
4.7.1Receiver (Oven with TES) Construction	42
4.7.2 Parabolic Trough Collector Fabrication.....	43
4.7.3 System Insulation and Sealing	45
4.7.4 Integration and Final Assembly	45
4.8 Experimental setup.....	47
CHAPTER FIVE	49
RESULT AND DISCUSSION	49
5.1. No-load test analysis	49
5.2 Bread baking test analysis.....	51
5.2.1 Sample bread baking test	52
5.2.2 Full bread baking test result	55
5.3 performance evaluation of the solar bread baking oven	58
5.3.1 Thermal efficiency of the oven	58
5.3.2 First figure of merit (F1)	59
5.4 Discussions	59

CHAPTER SIX.....	62
CONCLUSION AND RECOMMENDATION.....	62
CONCLUSION.....	62
RECOMMENDATION	62
REFERENCE.....	64
Appendix	68
Schematic drawing of all parts of the parabolic through solar collector bread baking oven integrated with thermal energy storage (pebble bed) with Solid work	68

List of figures

Figure 2.1 A)Traditional cooking and baking techniques; B)Open fires (Gulicha method)	7
Figure 2.2 A)solar baking unit & B) solar coking	10
Figure 2.3 Direct solar bread baking oven	11
Figure 2.4 Indirect solar cookers: a flat-plate solar cooker	12
Figure 2.5 Latent-heat storage type flat-plate Indirect solar cooker featuring an outdoor section with an elliptical cross-section.....	13
Figure 2.6 Indirect solar injera baking	14
Figure 2.7 Classification of solar thermal collector.....	17
Figure 2.8: Schematic of a parabolic trough collector	18
Figure 3.1 A) Data logger, B) CM3 Pyranometer, C) Thermocouple, D) digital weight balance	26
Figure 3.2: Methodology of the study.	28
Figure 4.1 Schematic drawing of the system	32
Figure 4.2 schematic drawing of the oven integrated with thermal energy storage	38
Figure 4.3 Parabolic trough collector geometry	40
Figure 4.4 the schematic drawing of parabolic through collector with all components.....	41
Figure 4.5 A-I manufacturing process of receiver oven integrated with (pebble bed) TES.....	43
Figure 4.6 A-E Manufacturing process of parabolic through collector.....	44
Figure 4.7 A) The acrylic glass cover and B) the ply woods as insulator and frame.	45
Figure 4.8 Manufacturing processes of the components, different view of the oven and extraction of the Patra and final assembly image of oven	47
Figure 4.9 experimental setup	48
Figure 5.1 temperature variation and solar radiation vs time graph for first no load test	50
Figure 5.2 temperature variation and solar radiation vs time graph for second on no load test result....	50
Figure 5.3 temperature variation and solar radiation vs time graph for third on no load test.....	51
Figure 5.4 temperature variations, solar radiation vs time graph and sample bread baking first test result	53
Figure 5.5 temperature variations, solar radiation vs time graph and sample bread baking second test result	54

Figure 5.6 temperature variations, solar radiation vs time graph and sample bread baking third test result 55

Figure 5.7 temperature variations, solar radiation vs time graph and full bread baking first test result .. 56

Figure 5.8 temperature variations, solar radiation vs time graph and full bread baking test second result 57

Figure 5.9 temperature variations, solar radiation vs time graph and full bread baking third test result. 58

List of tables

Table2.1: Typical parameters of thermal energy storage methods (IRENA -ETSAP, 2013) 14

Table 2.2 Summery of different literatures without thermal storage 20

Table 2.3 Summery of different literatures with thermal energy storage 21

Table 3.1 Material Selection and Corresponding Components 25

Table 3.2 Thermocouple Types 26

Table 5.1 comparison of bread profile after baking and there mass 60

ABBREVIATION AND ACRONYMS

CSP	Concentrated solar power
CPC	Compound parabolic collector
CST	Concentrated solar thermal
DSG	Direct steam generator
ETC	Evacuated tube collector
HTF	Heat transfer fluid
PCM	Phase change material
PTC	Parabolic trough collector
PTR	Parabolic trough receiver
PTSC	Parabolic trough solar collector
PTSPP	Parabolic trough solar power plant
RHS	Rectangular hollow sections
SAF	synthetic aromatic fluid
TES	Thermal energy storage
WHO	World Health Organization
IEA	International Energy Agency
PV	Photo Voltaic
HAP	Household air pollution
LPG	Liquefied petroleum gas
COPD	Chronic obstructive pulmonary disease

SDG 7	Sustainable Development Goal 7
BRICS	Brazil, Russia, India, China and South Africa
SDEWES	Sustainable Development of Energy, Water and Environment System
PBSS	Packed bed storage system

CHAPTER ONE

INTRODUCTION

1.1 Background

Wood remains the most commonly household surveys reveal used for cooking or meal preparation. Fuel, followed by natural gas, liquefied petroleum gas (LPG), and electricity in many developing economies, is used for that purpose. Due to that air pollution and health risk is the rapidly increasing to overcome this problem using clean energy technology in rural and low-income area such as solar cooker or ethanol is the best solution because they are no harmful and are renewable. Even among wealthier households, charcoal and kerosene are often preferred due to limited access to gas infrastructure and affordability issues. The preference for gas, where available, is frequently shaped by government fuel subsidies, infrastructure development, and historical pricing trends. While urban areas with stable electricity sometimes shift toward electric cooking, rural regions continue to rely heavily on biomass(Kojima, 2021).

The World Health Organization (WHO) said that around 2.1 billion people in the world still cook on open fires and bad stoves using wood, coal, or oil. This is bad for their health. It causes the air inside homes to turn dirty. This dirty air is linked to about 3.2 million deaths every year. This includes more than 237,000 young kids under five. Both inside and outside air pollution together lead to about 6.7 million deaths too soon each year. Sickesses like stroke, heart disease, long-term lung damage, and lung cancer come mostly from this dirty air at home. Women and kids feel the most harm because they often do the cooking and gather the fuel. WHO urges that we need to move fast to bring in cleaner fuels and better ways like solar, electric, gas from waste, LPG, and good biomass stoves that pass clean air rules (WHO, 2024).

The aim of SDG 7 is to make sure that by 2030, everyone can use clean, cheap, good, and new energy. But, new studies on how the world gets to use energy show that many places in Africa are far behind on this goal. Checks on clean fuel use and how much green energy is used show a drop in using green power and slow steps toward better cooking ways. In some places, fights over

keeping jobs in oil and gas make it hard to move to new energy. Even so, more bad weather events from climate change make it clear we need to move faster to clean energy. To close this gap, putting money into green power tech seems like the best way to help a fair and full move to low-carbon lives (Nhamo et al., 2020). Tech ways in clean cooking, like solar ovens, show hope. But not many remote towns use them yet. Reports tell us that how people act, their way of life, and issues with supply greatly block the use of better cook tech (Chattopadhyay, 2024).

These issues include low knowledge, cost fears, and weak spread nets. So, answering the woes of home air dirt needs new ideas and plans, and things that make people take in clean choices. This shows a big gap in getting to energy and points up the need for cheap, clean cook tech like sun heat ovens with power save, which can last without the need for grid power or cheap gas. Harm from old cook fuels goes beyond air dirt and health woes, but also hurts forests. In many poor lands, wood and burn stuff are the main cooking fuel, which ups the cutting of trees. A study of 92 lands from 2000 to 2015 found that getting to clean fuels and cook tech slows tree cutting a lot (Bakehe et al., 2023). Particularly in rural and agricultural regions where biomass use is high this evidence reinforces the need for affordable and accessible clean cooking alternatives. Renewable energy source such as, solar thermal ovens which operate without the need for electricity or firewood offer a promising solution for reducing environmental pressure while supporting sustainable development objectives.

The transition to renewable energy sources is essential to achieving the United Nations Sustainable Development Goals (SDGs), particularly in developing countries where access to clean cooking solutions remains a challenge. A recent study analyzing the SDGs across BRICS countries emphasized that while renewable energy sources such as hydropower and technological advances like ICT contribute significantly to sustainable development, solar and wind energy require more efficient systems and better integration to make a meaningful impact (Pata, 2025) . This highlights a critical need for research focused on improving solar energy technologies for practical applications such as clean and sustainable cooking methods to meet energy access targets and reduce environmental harm.

Recent studies show big tech steps up in green power sources like solar heat, solar power, and save setups. A full look at green power shown at the SDEWES meets points out key moves up in things like solar heat using flat plate and tube parts, stuff that can save heat (PCM), and front wall

parts to fit small places. These new things are made to boost how well systems work and handle heat needs, helping sun tech work well for many uses (Østergaard et al., 2020). However, the review also identifies challenges such as the need for reliable energy storage solutions, especially in solar powered systems designed for off grid or time shifted use, which directly aligns with the objectives of solar thermal baking ovens. This supports the rationale for integrating thermal energy storage (TES) with solar ovens to enhance their performance and reliability for baking in rural areas without consistent electricity access.

In the countryside of Ethiopia, many homes do not have power. They use wood for cooking. This causes health issues from the smoke inside homes and hurts the trees and the earth's weather. Solar power is a good choice, and some solar baking ovens are now better. One type put a curved reflector under the oven to make more heat, getting up to 121.1°C. This could cut down cooking time. Systems like this might help fix energy troubles in country places (B. Y. Mekonnen et al., 2020).

Injera and bread are the main foods in Ethiopia, Eritrea, and some parts of East Africa. They need a lot of heat to cook. In small towns, people use wood and other raw fuels to bake Injera. In big cities, they use electric ovens if they can. To cut down on the fuel they use, new ovens like Mirt, Burayou, Sodo, Awuramba, and Tehesh have been made. They use less fuel than old three-stone fires. For example, old fires use 929 g of fuel for each kg of Injera, but Mirt and Awuramba ovens use only 535 g/kg and 573 g/kg. Now, there are also solar and biogas ovens that heat up to 148°C to 225°C. Even so, we need more work to make these ovens better at keeping heat and cooking Injera well all the time (Adem et al., 2017; Tadesse, 2020).

This work looks to fix the lack of heat for cooking and baking in small towns and poor places. In these spots, old ways of cooking use a lot of wood and old fuels, which causes loss of trees, harm to land, and more harmful air gases. Solar power is a lasting pick that can cut down on harm to the earth and help with clean cooking. This study puts effort into making and testing a solar heat baking setup joined with heat saving, trying to give a better and greener way to bake bread in places without power.

1.2 Statement of the problem

Many people in Ethiopia live in the countryside, with little to no access to new cooking tech. As a result, women and kids spend lots of time getting firewood, facing big health risks from long hours of smoke when they cook. The smoke from burning fire wood gives off carbon monoxide smoke, and CO₂, adding to lung issues, making the greenhouse effect worse, and changing the climate. In places without choices like power, using or creating a solar system to bake bread can be a good fix. It saves time and cuts the health dangers from old ways of cooking. Dependence on firewood, cow dung, crops, and oil fuels harms trees, the land, and the air. Without help, these problems will stay, causing big future damage to nature and health. This study aims to make an effective solar bread baking system that uses strong solar power as a heat source, with added heat storage. This smart method will allow baking bread all day, even with little sun, giving clean, sure, and lasting power for these areas.

1.3 Objective of the Study

1.3.1 General Objective

The general objective of this study is to design, manufacture, and test a concentrating solar bread baking oven integrated with thermal energy storage.

1.3.2 Specific Objectives

The specific objectives include;

- To design the solar bread baking oven.
- To design a concentrating solar bread baking system collector.
- To size the thermal energy storage to be fitted with the concentrated solar bread baking oven.
- To fabricate the concentrating solar collector bread baking oven integrated with thermal energy storage.
- Experimentally tasting solar bread baking systems.

1.4. Significance of the research

In Ethiopia, people eat bread a lot. They have it for breakfast, during coffee times, and on big days. But, making it mostly needs old fuels, animal waste, or wood, which is bad for nature and health. Women and kids, who often get the wood, breathe in smoke and get sick with lung problems. Also, using a lot of wood cuts down trees, makes the air dirty, and adds to climate woes. Using solar power to bake bread is a good fix. It cuts down on the need for old fuels and lessens health and tree issues. This means cleaner air, fewer tree cuts, and less bad air stuff. When done, this plan will help people in the countryside who don't have power. It gives them a way to bake bread that's clean, cheap, and keeps renewing itself.

1.5. Limitations

This work only looks at the real-life test of a solar bread baking set that has a heat saving part and does not look at any guesswork or fake tests. The system experimentally tested in mostly cloudy and fluctuating weather condition due to that it affects the test result. Also, the study looks at just one kind of oven and heat saving setup, which might not work the same for other kinds or big bread making jobs. More studies are needed to make the system work better, last longer, and cost less for more people to use it. Due to not getting appropriate measuring instrument during testing days it delay the paper. This experiment only conducted in 5kilo AAiT campus in Addis Ababa, Ethiopia because of not sufficient time to test in other country.

1.6. Organization of the research

This research is structured into five chapters. Chapter One provides an introduction to the study, including the background, problem statement, and research objectives. Chapter Two presents a comprehensive literature review of related studies and existing technologies. Chapter Three outlines the materials and methods used in the study, Chapter four detailing the design, construction, and experimental procedures. Chapter five presents the results of the experimental investigation and discusses their implications. Finally, Chapter six concludes the study and provides recommendations for future research and development in the area of solar baking technology.

CHAPTER TWO

LITERATURE REVIEW

2.1 Introduction to solar energy

In lots of homes, cooking takes up a lot of power, especially where places that are just developing. Here, old kinds of fuel such as wood, coal, and dung are used the most. People pick these because they are simple to find and cost less. But they bring big health, green, and social costs. The smoke from cooking with these fuels inside can make people sick in their chests and lungs, mostly women and kids. Also, cutting down trees for wood fuel badly hurts the forests and the land (IEA, 2021, 2022).

In Ethiopia, many people who live in the country or near the city use old ways to bake. They light open fires or use clay ovens. These are called "mitad" for making Injera or clay stoves for bread. These methods are not good at using fuel and make a lot of smoke (Tadesse, 2020). The growing population and increasing energy demand have further strained access to clean cooking solutions. Therefore, there is an urgent need to explore sustainable, clean, and locally appropriate cooking technologies that can reduce reliance on biomass.

Using sun heat technology is a great pick for making food and bread hot. Sun ovens, like those with focus setups such as curved mirrors, given the strong heat needed to bake without harming the air like usual fuels do. But one big problem in using solar heat is that it must have direct sunlight. To fix this, heat keep systems, like rock beds or heat keep stuff, are now more commonly used in sun ovens to keep heat. This lets people make food even when the sun is not out or comes and goes. (Kalogirou, 2004; Sharma et al., 2009) .

This literature review examines the existing research on traditional baking practices, the development of solar cooking technologies, and the role of TES in improving reliability and performance. It also identifies current research gaps and highlights the potential contribution of the present study on the experimental development of a direct solar bread baking oven integrated with thermal energy storage, with a focus on applications in rural Ethiopia.

2.2 Traditional Cooking & Baking

In Ethiopia, the old ways of making food are a big part of the country's way of life, more so in the countryside and towns, where new energy ways are still hard to find. Most homes use solid materials such as wood, farm waste, and animal waste for cooking and baking. They burn these in old fire setups like the three-stone fire, mogogo (a clay oven), or mitad, a round, flat clay or metal plate mainly used to bake injera (Eshetu, 2024). Baking uses a lot of power in homes in Ethiopia. Baking bread (dabo) and injera needs high heat for a long time. People often burn a lot of wood or crop bits to get this heat. These old baking ways are not very good at using heat, often using less than 15% of it, leading to a lot of fuel being used. Also, these stoves don't have good heat covers or ways to control the fire. This causes a lot of smoke inside and wastes heat (Adem et al., 2019). The bad health effects from using old ways of cooking are significant. In rooms with bad air flow, women and kids face a lot of small, bad air bits (PM2.5), carbon gas (CO), and other unsafe air bits. The World Health Organization (WHO, 2022) thinks that over 21,000 early deaths happen each year in Ethiopia from sickness caused by the bad air inside, like lung problems, heart issues, and strokes. Most people who use these are from places with low and middle incomes, where new and clean ways to cook are hard to get or too pricey for many. Around the world, about 2.1 billion people still use hard stuff like wood, crop bits, dung, black rock, and oil for their daily food making. They burn these in open fires or old stoves that don't burn well and waste energy (WHO, 2024). As shown in Figure 2.1, several types of traditional cooking and baking techniques are represented.



A)

B)

Figure 2.1 A) Traditional cooking and baking techniques; B) Open fires (Gulicha method)
(Kedir et al., 2019)

2.3 Biomass Energy Use and Its Role in Ethiopia's Cooking Sector

In Ethiopia, biomass is the key source of power, making up about 89% of the main power used. It is the main thing used to cook and bake in places with lots of land and some town spots. Usual power sources like wood, plant waste, and animal waste are used a lot, mostly in places with lots of land where it's hard to get power from the power grid and clean power. On the other hand, about 90% of townhomes use power mostly for light, while land-rich places still rely a lot on biomass to meet their heat needs. Many homes and the whole country rely a lot on biomass. Ethiopia has a lot of it for energy use. Some new studies show that in 2014-2015, Ethiopia had about 1,120 million tons of biomass. Each year, this can make as much energy as 46.91 million tons of coal. Also, around 18 million tons of farm waste can be used right away (Berhanu et al., 2017).

Another study notes that 141.8 million metric tons of biomass (including woody biomass, crop residues, and dung) are available annually, with only 71.9 million metric tons currently exploited. Despite this vast resource potential, Ethiopia's use of modern biomass energy technologies such as biogas, bioethanol, or biomass-based electricity generation remains extremely limited, with only 0.58% of the country's electricity generated from biomass (Benti et al., 2021). The majority of biomass consumption is still based on traditional, inefficient combustion systems like open fires and rudimentary clay stoves, which result in high fuel consumption and significant indoor air pollution.

One study finds that each year, 141.8 million metric tons of biomass (like wood, crop parts, and dung) is there to use, but only 71.9 million tons are used now. Even with so much resource, Ethiopia's use of new biomass power tech (like biogas, bioethanol, or from-biomass power making) is still very low. Just 0.58% of the country's power comes from biomass.

Moreover, the broad use of biomass hurts the environment, chiefly trees being cut, soil wearing away, and land getting worse. The need for wood to burn can lead to too much cutting. Also, using farm leftovers and dung as fuel can harm the soil's health and reduce how much crops grow (Berhanu et al., 2017). These challenges are compounded by limited investment, weak institutional support, poor infrastructure, and lack of awareness regarding clean energy alternatives (Wassie, 2020).

Still, the huge supply of biomass gives Ethiopia a big chance to grow bioenergy ideas, as long as they use lasting feed plans and new ways to change it (like no-air breakdown, turning into gas, and heat breakdown). If they grow the use of new biomass and add other new energy types like sun heat cook setups with heat hold, it could lead to a strong move towards energy safety, caring for the environment, and better health.

2.4 Solar Cooking Technologies

Solar cooking is a clean, sustainable, and increasingly viable alternative to traditional biomass-based cooking methods, particularly in regions with abundant solar radiation such as Ethiopia. Solar cooking technologies harness the sun's thermal energy to cook food without the use of polluting fuels, reducing deforestation, indoor air pollution, and health risks (B. A. Mekonnen et al., 2020). Cooking using solar energy is a long-established practice and not a recent technological development. As noted by Halacy and Halacy, one of the earliest known experiments in solar cooking was conducted by the German physicist Tschirnhausen (1651–1708), who utilized a large lens to concentrate solar rays and boil water in a clay pot. These early efforts were later documented in 1767 by Swiss scientist Horace de Saussure, who also found that wooden "hotboxes" he constructed could generate sufficient heat to cook fruit (Sedighi et al., 2014). August Mouchot published the first book on solar energy titled *"Solar Energy and its Industrial Applications."* In 1877, he developed solar cookers intended for use by French soldiers stationed in Africa. The following year, in 1878, he showcased a solar concentrator at the Paris Exhibition (GTZ and DME, 2002b). During the 1980s, several key organizations in solar cooking were established, including the ULOG group in Switzerland, EG Solar in Germany, and Solar Cookers International. The contributions of Barbara Kerr and Sherry Cole led to the development of a simple, user assembled solar cooker kit, which later became the basis for the solar panel cooker introduced by Solar Cookers International a model that continues to be used today (Knudson, 2004). In figure 2.2 below shows different types of solar cooking images.



A)

B)

Figure 2.2 A)solar baking unit & B) solar coking (Ayub et al., 2018
(Tavakoli et al., 2022).

2.4.1 Classification of Solar Cookers

Solar cookers are divided into two main categories: direct and indirect, based on how heat is delivered to the cooking pot. In direct solar cookers, solar radiation is used directly for cooking, whereas indirect solar cookers employ a heat transfer fluid to carry heat from the solar collector to the cooking chamber.

2.4.1.1 Direct solar cooker

It is the most common type available cooker due to their ease of construction and low cost in material. Among the commercially successful direct solar cookers are the box type and concentrating type designs. The box type solar cooker consists of an insulated enclosure that features either a single or multiple glass covers. The interior of the box is coated with black paint to enhance the absorption of sunlight (Muthusivagami et al., 2010).

(Harmim et al., 2010) conducted an experimental study on a box type solar cooker fitted with a finned absorber. Their findings showed that the solar box cooker with fins achieved approximately 7% higher efficiency compared to a traditional box type solar cooker. Additionally, the time needed to heat water to boiling was reduced by about 12% when using the finned absorber plate.

Box-type solar cookers present a number of advantages that make them practical and accessible. They are capable of utilizing both direct and diffuse solar radiation, and can accommodate multiple cooking vessels simultaneously. Their design allows them to function as simple ovens though not for crisp baking and they are lightweight, portable, and easy to operate. They require no solar tracking, and their moderate heat levels eliminate the need for frequent stirring. Additionally, food can remain warm until evening, and the cookers themselves are inexpensive and easy to construct or repair using locally available materials. However, these cookers also have limitations. Cooking is slow as it uses low heat, and you can only cook when the sun is up. The glass cover lets out a lot of heat, and it's not great for cooking things like fried or grilled food. The basic sort of a mirror cooker is made up of a curved mirror and a stand that holds the pot where the sun hits it best. A solar mirror cooker has a curved mirror, a pot at the sun's focus, and a stand for everything. These cookers use one or two ways to track the sun and can focus the sunlight up to 50 times to hit as hot as 300 degrees Celsius, making them good for cooking. There are two sorts of these: ones that send sun rays up from below and ones that beam them down from above. In just a few sunlit hours, the cooker can make tasty meals for 4-5 people at okay heat, cooking food well, keeping its good bits, and stopping it from burning or drying out. Figure 2.3 shows image of direct solar bread baking.

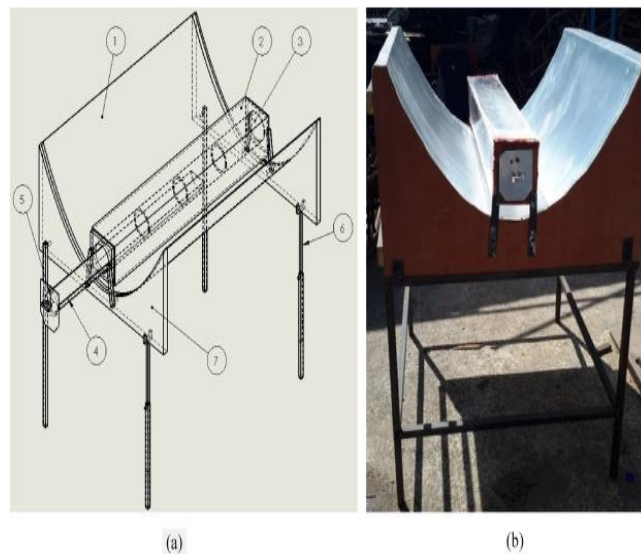

Figure 2.3 Direct solar bread baking oven (Aragaw et al., 2022).

2.4.1.2 Indirect Solar cookers

In indirect solar cookers, the cooking pot is located separately from the solar collector, and a heat transfer medium is needed to deliver the heat to the pot. Commercially available cookers in this category include those with flat plate collectors, evacuated tube collectors, and concentrating collectors.

(Balzar et al., 1996) designed a solar cooker that utilizes a vacuum tube collector. This system feature is a vacuum tube with integrated long heat pipes that directly transfer heat to the oven plate. Solar cookers based on vacuum tube collector's offer several benefits: they operate without the need for solar tracking, can achieve high temperatures, and allow cooking to occur indoors or in shaded areas due to the physical separation between the collector and the cooking chamber.

(Schwarzer et al., 2003) developed a flat plate solar cooker that can be integrated into the structure of a kitchen, as illustrated in Figure 2.4. The system consists of two main components: solar collectors equipped with reflectors and a cooking unit. Peanut or sunflower oil is used as the heat transfer medium, and the design features two fixed (non-removable) cooking pots. One of the drawbacks of this design is the fixed pots, which make it challenging to clean and serve food.



Figure 2.4 Indirect solar cookers: a flat-plate solar cooker (Schwarzer et al., 2003)

(Hussein et al., 2008) developed an innovative indirect solar cooker featuring an outdoor section with an elliptical cross-section, wickless heat pipes, a flat plate solar collector, and an integrated indoor cooking unit with PCM-based thermal storage, as illustrated in Figure 2.5. The system was built and tested under real weather conditions in Giza, Egypt. To increase solar radiation on the

collector, two flat reflectors positioned to face south and north were incorporated. Magnesium nitrate hexahydrate, with a melting point of 89 °C and a latent heat of fusion of 134 kJ/kg, was used as the phase change material (PCM) inside the indoor cooking chamber. Results showed that the use of the reflectors led to an average daily increase of approximately 24% in the solar radiation received by the collector.

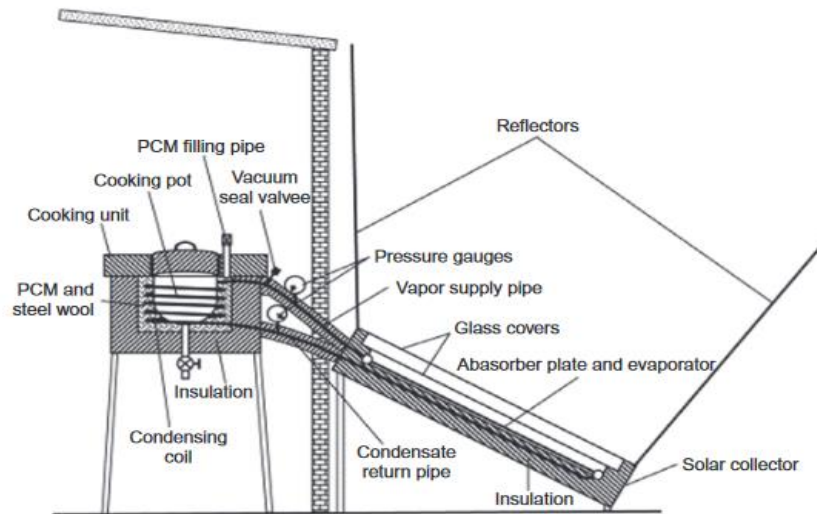

Figure 2.5 Latent-heat storage type flat-plate Indirect solar cooker featuring an outdoor section with an elliptical cross-section (Hussein et al., 2008).

(Chen et al., 2008) conducted a theoretical study on the application of various phase change materials (PCMs) for thermal energy storage in box-type solar cookers. The PCMs analyzed included magnesium nitrate hexahydrate, stearic acid, acetamide, acetanilide, and erythritol, using a two-dimensional enthalpy-based simulation model considering only heat conduction. The study also examined the effect of different heat exchanger container materials such as glass, stainless steel, tin, aluminum and aluminum alloy and copper. Findings revealed that while the initial temperature of the PCM had little influence on melting time, the boundary wall temperature played a critical role in the melting process. The thickness of the container material had minimal effect, and high thermal conductivity of the container material showed limited benefit unless extremely low. Among the PCMs tested, acetamide and stearic acid were identified as the most suitable for retaining heat in the evening to support extended cooking or food warming. Figure 2.6 shows image of indirect solar cooker.



Figure 2.6 Indirect solar injera baking (Tesfay et al., 2019)

2.5 Thermal Energy Storage (TES) Materials

The nature of solar energy is diluted and intermittent, thermal energy storage (TES) stores energy for a particular time and provides this energy for later usage. Energy storage is used to correct the mismatch between the time of energy supply and energy demand. Solar energy can be stored in different forms like electrical, chemical, mechanical, and thermal energy. The desired properties while selecting thermal energy storage include High energy density (per unit mass or per-unit volume) in the storage material, Good thermal properties, Mechanical and chemical stability of storage material, Compatibility between storage material, HTF, and other materials, complete reversibility for a large number of charging/discharging cycles, minimum thermal losses and it has also minimum cost (Alva et al., 2018). According to the experimental data summarized in Table 2.1, the typical parameters of thermal energy storage methods are presented based on IRENA-ETSAP (2013).

Table2.1: Typical parameters of thermal energy storage methods (IRENA -ETSAP, 2013)

Type	Storage capacity (kWh/t)	Power (MW)	Efficiency %	Storage period
Sensible heat storage	10-15	0.001-10	50-90	Day/month
Latent heat storage (PCM)	50-150	0.001-1	75-90	Hour/month
Chemical storage	120-250	0.01-1	75-100	Hour/ day

2.5.1 Sensible Heat Energy Storage

Sensible heat storage materials are defined as a group of materials that undergo no change in phase over the temperature range encountered in the storage process. The capacity of a material to store sensible thermal energy is greatly influenced by its density and heat capacity, which collectively determine its thermal capacity. For a material to be useful in a thermal energy storage application, it must be inexpensive and have good thermal capacity. Another important parameter in sensible thermal energy storage is the rate at which heat can be released and extracted. This characteristic is the function of thermal diffusivity. The material here can be a liquid or a solid (Mohamed et al., 2017). The PBSSs, which solely offer sensible heat storage, have been in operation for the past few decades. Materials with a high specific heat that can store a sizable quantity of thermal energy by raising their temperature are used as packing materials in a PBSS. Commonly used, sensible materials for heat storage include masonry, pebbles, clay, rocks, and concrete. The mass of the storage medium, the temperature differential between the material's starting and final states, and its specific heat capacity all affect how much sensible energy is stored in the materials. One practical method for storing solar thermal sensible heat energy is a packed bed storage system, which may be set up with a variety of solar thermal applications at both low and high temperatures (Gautam et al., 2020).

2.5.2. Latent Heat Energy Storage System (LHESS)

A latent heat energy storage system (LHESS) is used to store the existing thermal energy for later usage and increases its utilization. Further, it provides a favorable solution for smoothing the inconsistency between energy demand and supply. LHESS uses phase change materials (PCM) as energy storage mediums. Energy is stored during melting and released during solidification.

Several types of research have used LHESs for various applications such as solar domestic hot water systems (Mazman et al., 2009).

According to (Osterman et al., 2012)) a latent heat thermal energy storage unit has three key parts. The first is the phase change material (PCM); picked for its heat traits and a melting point that fits the needed heat range. The PCM absorbing and releasing heat when it changes form. The second part is the heat transfer, which could be a solid or a fluid that gives heat to the PCM. Since many PCMs move heat slow, a big area to swap heat is often needed for good heat move. The third part is the right box (container) to keep the PCM. This box must work well with the PCM's chemo traits, mainly to fight wear and keep the unit working long.

2.6 Solar thermal collector

A solar thermal collector works by capturing sunlight and turning it into useful heat. Even though the phrase "solar collector" often means systems that gather heat, it also includes big energy setups like curved mirrors and tall solar towers, and tools for other uses, like solar ovens and solar air warmers. These collectors act like special heat swap devices that change solar light into heat energy in a moving heat exchange fluid, like air, water, or oil. The main part of any sun power set-up is the collector. It takes in sun rays and moves the heat to the fluid it works with. This hot fluid can then go to things like water heaters and air systems, or it can stay in heat storage tanks. This lets us use the heat when the sky is grey or at night. There are two big kinds of solar collectors: non-concentrating (still) and concentrating types. Non-concentrating collectors keep the same area for catching and taking in sun rays. On the other hand, concentrating collectors use shiny curved parts and tracking gear to send sunlight to a smaller spot, making the heat stronger at that point (Kakoko et al., 2023).

Stationary solar collectors remain fixed in one position and do not follow the sun's movement. This category includes three main types: flat plate collectors (FPC), stationary compound parabolic collectors (CPC), and evacuated tube collectors (ETC). Concentrating collectors provide several advantages over traditional flat-plate collectors. The key difference lies in their ability to reach higher working fluid temperatures using the same solar collection area. This results in improved thermodynamic performance and greater thermal efficiency, primarily due to the smaller heat loss surface to the absorber area. Additionally, the use of reflective surfaces in concentrators reduces

material requirements and simplifies the structure compared to flat-plate collectors (FPCs), making the cost per unit area of the solar collecting surface lower. Concentrators may utilize reflective or refractive surfaces and come in various shapes, including cylindrical or parabolic, and may be designed as continuous or segmented. The receiver components also vary in shape such as flat, cylindrical, concave, or convex and may be either glazed or unglazed. (Kalogirou, 2003). In figure 2.7 below shows classification of solar thermal collector.

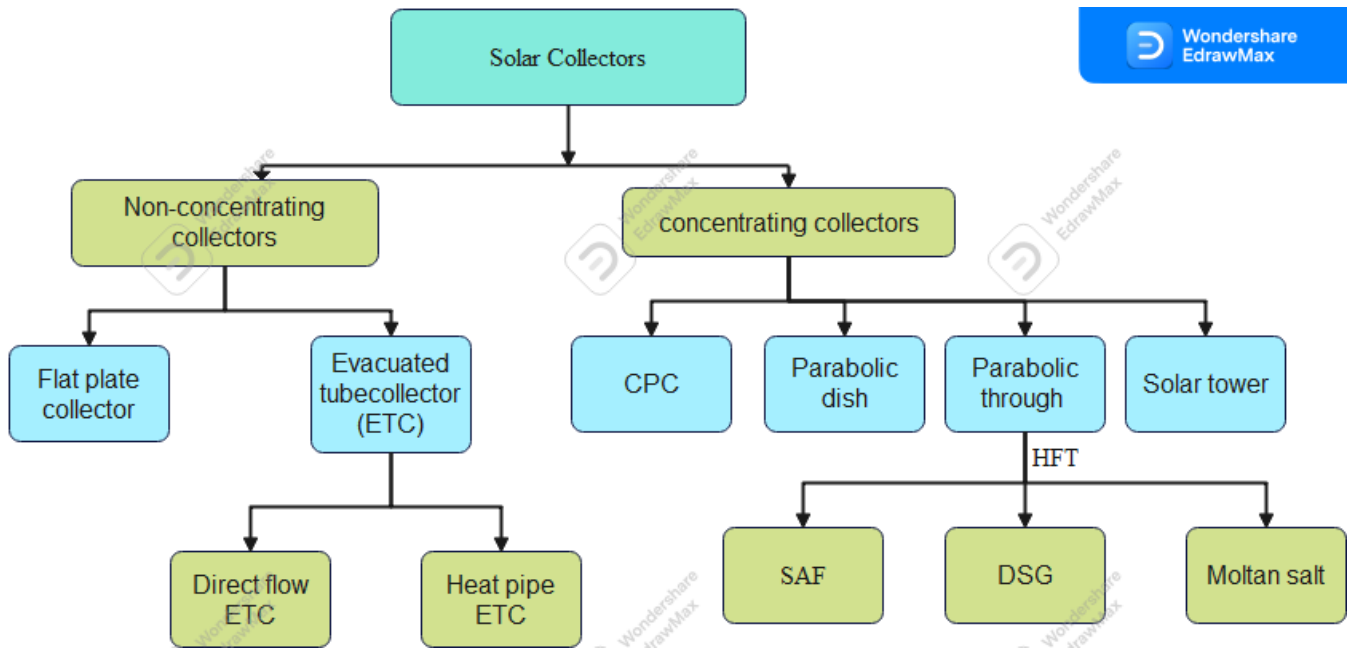

Figure 2.7 Classification of solar thermal collector(Nagarajan et al., 2010)

2.6.1. Parabolic Trough Solar Collector

Parabolic trough collectors (PTCs) concentrate direct solar radiation along a focal line positioned along the collector's axis. To achieve efficient transport of high-temperature heat, a high-performance collector design is essential. PTCs offer a lightweight and cost-effective solution for generating process heat, capable of operating efficiently within a temperature range of 50 °C to 400 °C. These systems are well suited for medium to high temperature applications. Figure 2.8 shows a schematic representation of a parabolic trough collector (Abed et al., 2020).

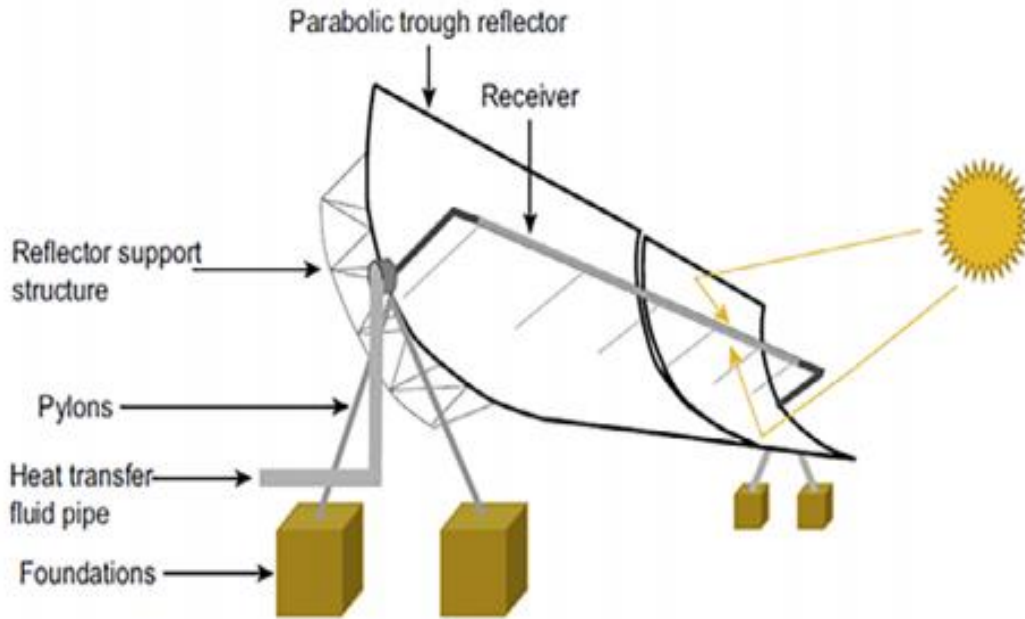

Figure 2.8: Schematic of a parabolic trough collector (Abed et al., 2020)

(Abbood et al., 2019) They tested the heat skills of a curved solar heat tool (PTSC) by checking how it did with different parts. The parts they examined were the heat transfer fluid (HTF), hydraulic oil, ethylene glycol-water mix, and plain water, as well as three different flowrates: 1 LPM, 2 LPM, and 3 LPM. The end show was that the best heat and best work were when they used hydraulic oil at the top speed. At 3 LPM, the most heat gain was 1.035 kW with hydraulic oil, 0.879 kW with ethylene glycol-mix water, and 0.734 kW with water. The top heat work rates were 46.2% for hydraulic oil, 43.5% for ethylene glycol-mix water, and 40.7% for water, all at the top speed they tested.

(Marif et al., 2014) Looked at how well a solar scoop that bends light and heat works in the hot dry land of the Algerian Sahara. They used a simple step-by-step math way paired with an energy check method. The part that soaks up heat was made by using energy check rules on each bit of the system, like the glass cover, tube that soaks heat, and the fluid that moves heat. The check showed that full light following made a high light power rate of 73.92%. Of the ways to follow the sun, the one-line North-South and flat East-West ways were seen as the best for top work of the scoop that bends light all year long.

(Laaraba et al., 2020) Looked into ways to make the heat work of a curved trough better by adding flat fins on the lower half of the inner side of the tube that takes in heat. Their tests showed that having fins made the heat work a lot better than with a smooth tube. The study also found that more mixing in the flow made the heat move better and longer fins helped improve heat moving even more.

2.7 Thermal Insulation

Insulation refers to materials or combinations thereof that slow down the transfer or loss of heat. It is widely applied in heating, air conditioning, and refrigeration systems to conserve thermal energy, prevent condensation on surfaces, and regulate heat flow to contained fluids. In the context of solar cookers, insulation is essential for enhancing heat retention and boosting cooking efficiency (Aremu et al., 2015). In solar cookers, you'll often find insulation stuff like aluminum foil, rock wool, and rice hulls. They pick these for how well they hold heat and if they are easy to get. They use them alone or mix them up, based on the cooker's look and needs. With the right insulation, solar cookers can grab and use solar power well and keep the heat in. (Aremu et al., 2015).

2.8 Literature Summary

Many have looked at how to bake bread using wood, sun, or electric power. Each way has its good and bad points. Wood is used a lot in country places but can lead to health problems, high fuel costs, and harm to nature, like cutting down forests and adding to air pollution.

Electric ovens have some wins over wood. They keep the air clean, save trees, and bake at a steady heat. But they need a steady power supply and can be expensive to run. In far-off places, they might not be easy to use. Power cuts and not having enough power are big problems in poor areas.

Sun-based ovens are a new, clean choice. They don't pollute and keep using power from the sun. Studies look at sun ovens that use the sun's heat right away or store it for later. They try to keep the heat longer, so you can cook even when it's cloudy or after the sun sets. Making the oven so it keeps warmth well is an important part of research. Some new findings show putting special materials in the bottom of solar ovens helps keep them hot longer. Also, lining them with aluminum foil and using a special sun focusing tool spreads the heat evenly inside the oven.

Study summary shows how ovens with and without heat storage compare. Table 2.2 illustrates the literature summary of different studies without thermal energy storage and Table 2.3 is with thermal energy storage.

Table 2.2 Summary of different literatures without thermal storage

	Title	Research output					Reference	
		Time to bake	Over all η (%)	Baking T (°C)	average solar radiation (W/m ²)	Stagnation temperature (°C)		specific heat capacity (%)
1	Design, Fabrication and Performance Evaluation of Solar Brick Oven	150min	16	150	850	-	-	(Maina et al., 2016)
2	Development and performance evaluation of tube-type direct solar oven for baking bread	51min	35	120	396	-	-	(Aragaw et al., 2022)
3	Experimental performance assessment of a solar powered baking oven	40min	78	200	760	-	-	(Forsythe et al., 2019)
4	Solar Thermal Application for Decentralized Food Baking Using Scheffler Reflector Technology	-	63	200–230	-	-	-	(Ayub et al., 2018)
5	Novel Method to Design and Construction a Dual-Purpose Solar Oven for Baking Bread	55-60min	-	-	-	-	92	(Tavakoli et al., 2022)

6	Design development and performance studies of a novel Single Family Solar Cooker	90min	-	-	945	144	-	(Mahavar et al., 2012)
7	Design optimization of solar cooker.	90min	-	-	-	163	-	(Mirdha et al., 2008)
8	Design, development and testing of a small-scale hybrid solar cooker	40min	38	-	948	108.9	-	(Joshi et al., 2015)
9	Portable solar cooker and water heater	150min	77	50	-	-	-	(Badran et al., 2010)
10	Experimental testing of a box-type solar cooker using the standard procedure of cooking power	90min	-	-	902.5	122	-	(El-Sebaili et al., 2005)

Table 2.3 Summary of different literatures with thermal energy storage

	Title	Heat transfer fluid	Melting temperature	Thermal energy storage	Time to store	Time to melt	Reference
1	Performance assessment of a solar domestic cooking unit integrated with thermal energy storage system	Therminol 55	152 °C	D-Mannitol	-	15min	(Kumaresana et al., 2016)

2	Numerical and experimental Analysis of Solar Injera Baking with a PCM Heat Storage	steam	220°C	solar salt (mixture of 40% KNO ₃ and 60% NaKO ₃)	240 min	-	(Asfaw H Tesfay et al., 2019)
3	Preparing side charging of PCM storage: theoretical and experimental investigation	-	350°C	mixture of 60% NaNO ₃ and 40% KNO ₃	-	480min	(A H Tesfay et al., 2015)
4	Solar powered heat storage for Injera baking in Ethiopia	-	135-160 °C	Solar salt	1day	245min	(Asfaw Haileselassie Tesfaya et al., 2014)
5	Experimental investigation of a cooking unit integrated with thermal energy storage system	-	155 °C	sunflower oil	-	5 min	(Kajumba et al., 2020)

This study addresses identified research gaps by experimentally investigating an improved solar bread baking oven. The system includes aluminum foil to supplement the PTSC, and integrates cost-effective, locally sourced TES materials positioned below the baking chamber. These enhancements are intended to improve the thermal efficiency and capacity of the oven, enabling it to function even during periods of low solar insolation. The modifications also support larger baking capacities by improving heat retention and distribution, thus making the system more practical and adaptable for off-grid rural communities.

CHAPTER THREE

MATERIALS AND METHODS

3.1 Introduction

This chapter presents the methods for designing the research design, the process model, the different sources and methods of collecting data, selection of materials and equipment, the presentation and analysis of experimental data, and the methods for conducting the investigation and performance evaluation of the present solar thermal bread baking system. This research utilizes both theoretical and experimental analyses to design, construct, and evaluating the performance of the solar thermal bread baking system. Using governing equations, the component parts of the solar thermal baking system are designed, sized, selected, and formulated in a theoretical manner. Experiments are used to determine the thermal efficiency of the parabolic trough collector (PTC) and latent heat storage (LHS) systems.

3.2 Materials

Finding the material that best fits the design specifications is the aim of the materials selection process. In order to choose a material, one must look for the optimum fit between the material's qualities and the component's design specifications. Materials were selected based on several critical properties including high thermal conductivity, non-toxicity, corrosion resistance, cost-effectiveness, and high thermal energy storage capacity. The materials, measurement equipment, and system components required for the development of the experimental prototype and measurement of system parameters are obtained from local markets in Addis Ababa cities (Ethiopia).

The materials used to construct the experimental apparatus were selected based on local material availability and cost-effectiveness. For the construction of a concentrated solar bread baking oven, various materials are selected, and their components are shown in table 3.1.

Table 3.1 Material Selection and Corresponding Components

No	Components	Material selected
1	Parabolic Reflector	Aluminum sheet
2	Receiver (Oven Body)	Aluminum sheet
3	Thermal Energy Storage (TES)	Pebble bed (natural or river pebbles)
4	Insulation for Oven	Plywood
5	Glazing cover	Polycarbonate (acrylic glass)
6	Structural Frame	Mild steel (painted or coated)
7	Reflector Support	RHS
8	Baking Tray	Aluminum sheet

SolidWorks software was used to design the various components of the solar bread baking system. For the performance evaluation, a set of measurement instruments was employed both during and after testing. Temperature measurements were recorded using k type thermocouples connected to a National Instruments data acquisition system (NI DAQ-9211). The data logger was interfaced with a computer, allowing continuous temperature monitoring and recording through LABVIEW software, which is compatible with the NI DAQ system. And also, the solar radiations were measured by the instrument called CM3 pyrometer integrated with the data logger. This setup enabled the precise tracking of oven and bread core temperatures over time. Additionally, a digital weighing balance was used to measure the mass of the bread before and after baking to assist in performance analysis. Image of digital weighing balance, the data logger, the pyrometer and thermocouples are shown in figure 3.1. And in table 3.2 describes the type of thermocouples and their properties.



A



B



C

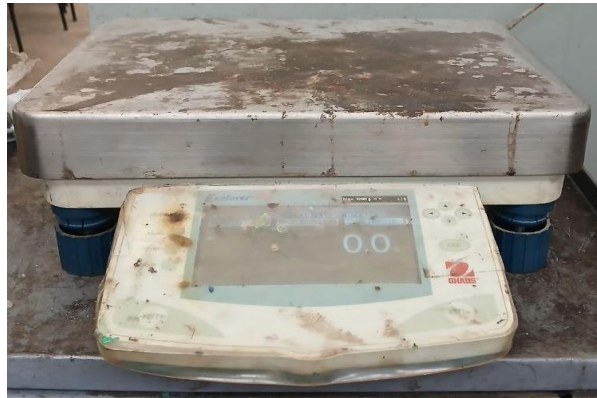

D

Figure 3.1 A) Data logger, B) CM3 Pyranometer, C) Thermocouple, D) digital weight balance

Table 3.2 Thermocouple Types (Watlow Electric Manufacturing Company 2025.)

Thermocouple type	Temperature range	Properties
B	1370-1700°C (2500-3100°F)	Easily contaminated, require protection.

C	1650-2315°C (3000-4200°F)	No oxidation resistance. Vacuum, hydrogen or inert atmospheres.
E	95-900°C (200-1650°F)	Highest output of base metal thermocouples. Not subject to corrosion at cryogenic temperatures.
J	95-760°C (200-1400°F)	Reducing atmosphere recommended. Iron leg subject to oxidation at elevated temperatures--use larger gauge to compensate.
K	95-1260°C (200-2300°F)	Well suited for oxidizing atmospheres.
N	650-1260°C (1200-2300°F)	For general use, better resistance to oxidation and sulfur than Type K.
R	870-1450°C (1600-2640°F)	Oxidizing atmosphere recommended. Easily contaminated, require protection.
S	980-1450°C (1800-2640°F)	Laboratory standard, highly reproducible. Easily contaminated, require protection.
T	-200-350°C (-330-660°F)	Most stable at cryogenic temperatures ranges. Excellent in oxidizing and reducing atmospheres within temperature range.

3.3 Methodology

This study was conducted using a methodology based on a predetermined objective. The research employs a hybrid approach, integrating analytical and experimental methodologies, with both quantitative and qualitative elements. The performance of the solar thermal bread baking system is evaluated based on a formulated hypothesis and validated through empirical testing. Both numerical and experimental methods were used in the process, which began with the model's preparation. The many governing equations are used in the numerical method. To do this work, the scientific literature was studied, and then theoretical and experimental analysis was done. Additionally, design work concluded on the proposed bread baking oven. Following that, the designed components were manufactured and tested. Experimental investigation was conducted, and the influence of numerous parameters including types of thermal energy storage size and medium on the performance of the bread was conducted. Figure 3.2 shows the general process layout of the methodology used in the research.

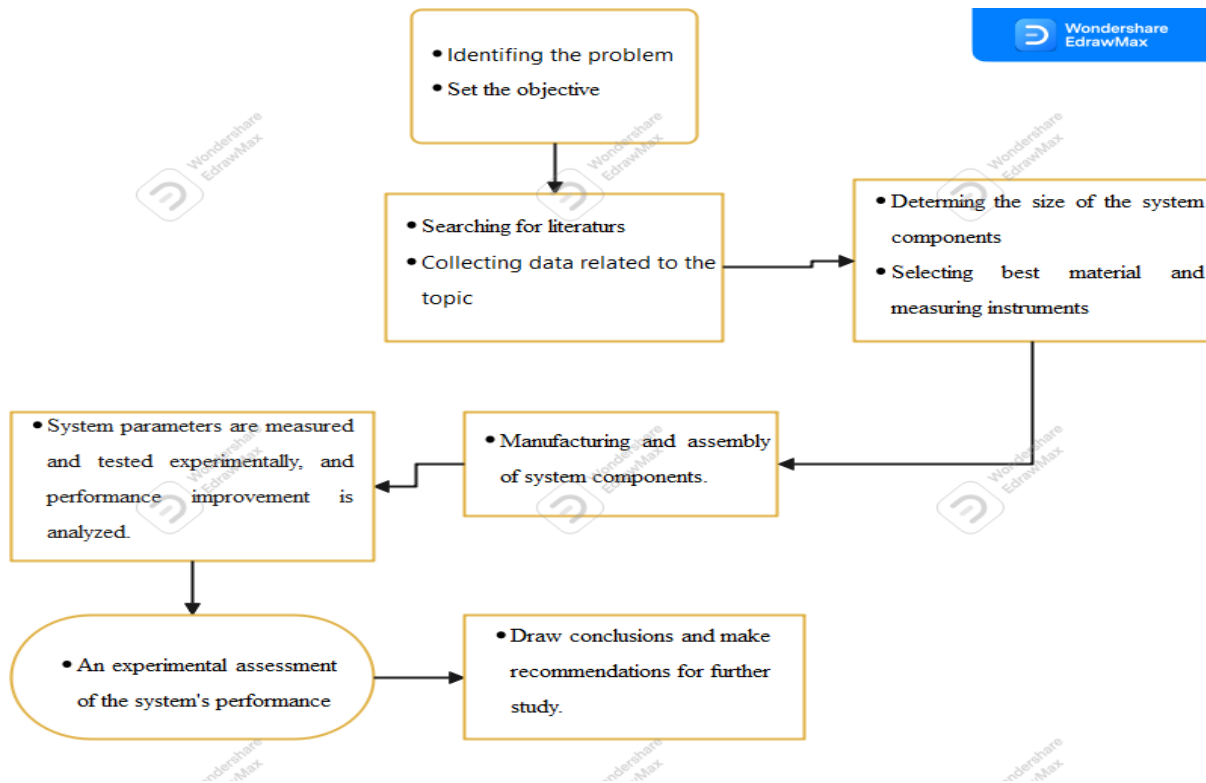

Figure 3.2: Methodology of the study.

3.3.1 Data collection methods

The study starts by collecting data from both primary and secondary sources of data. The primary data sources would be obtained by direct measurement of temperature, such as the ambient temperature of the air, the temperature of concentrated solar bread oven, the charging of thermal storage, and the temperature of the plate surface of oven. The solar radiation statistics for the site are collected from direct measuring by pyranometer in Addis Ababa, Ethiopia. Secondary data are gathered from several internet sources, including books, papers from websites, literature from local and worldwide journal articles, and data from extensive literature reviews.

3.3.2 Literature survey

The first step was to perform a review of the literature on solar energy bread baking ovens and their types. A review of the literature identified numerous methods and approaches for system model and design. Many research papers and publications were consulted to gather comprehensive information on existing solar baking technologies, performance factors, and key design parameters.

3.4 System Working Principle

The system operates by utilizing a parabolic solar collector to concentrate solar radiation onto a rectangular oven located at the focal line of the collector. The oven absorbs the concentrated solar energy, raising its internal temperature for bread baking. A thermal energy storage (TES) unit, consisting of a pebble bed placed at the bottom of oven, stores surplus thermal energy during peak sunlight hours and gradually releases it when solar intensity declines. A polycarbonate glazing cover is used to minimize heat losses, dust particles and improve thermal efficiency. This configuration enables simultaneous baking of 20 small pieces of Ethiopian style bread using clean and renewable solar energy. It has manually working tracking system at the side of the ply wood also for moving the parabola from east to west direction.

3.5 Testing Method

To evaluate the performance of the developed solar bread baking oven, two experimental tests were conducted: a no-load test and a bread baking test.

The no-load test was performed to determine the stagnation temperature of the oven and the preheating time required to reach baking conditions under direct solar radiation. During this test, the oven was operated without any load, and temperature readings were recorded at regular intervals using thermocouples placed inside the oven. The pebble bed temperature (TES), ambient temperature and solar irradiance were also measured throughout the test period.

The bread baking test was conducted to assess the actual baking capability and utilization efficiency of the solar oven. For this test, small-sized breads were prepared from dough with a known mass, and the baking process was monitored under typical solar conditions. The test was repeated on three different sunny days to ensure consistency. During the test, the core temperature of the bread, the oven air temperature, TES temperature, solar radiation and the ambient temperature were recorded every 5 minutes using thermocouples. The thermocouple wires were carefully routed through the oven door and sealed with high temperature resistant silicone to prevent heat and vapor loss. The time required to fully baking the bread and any temperature variations were carefully observed and documented for performance analysis.

CHAPTER FOUR

DESIGN OF SOLAR BREAD BAKING OVEN WITH THERMAL ENERGY STORAGE

4.1. Description of the overall concept of solar bread baking oven

The solar bread baking system developed in this study uses solar radiation as the energy source for the bread baking device. A parabolic trough collector is used to gather solar energy and transform it into usable heat. The purpose of the parabolic trough collector is to collect incoming solar radiation and raise the receiver's temperature. The Parabolic Trough Solar Collector (PTSC) is made of silver-coated aluminum material that focuses sunlight onto the focal length. The concentrated sunlight generates high temperatures at this focal point, where the receiver rectangular box-type oven is positioned.

To enhance the collection of solar radiation, aluminum foil is added to both sides of the ply woods. This aluminum foil directs sun radiation on to the receiver and parabolic trough collectors increasing the amount of concentrated solar energy available for baking. The direct bread baking oven is placed at the focal length of the PTSC, and it is made of aluminum sheet due to good conductor of heat and it's low-cost. This oven captures the concentrated solar energy to bake the bread directly.

Thermal Energy Storage (TES) uses a pebble bed as the storage medium. The pebbles absorb and store excess heat when sunlight is abundant. This stored heat can then be released later to maintain a consistent baking temperature, even when solar input fluctuates. The integration of the system involves placing the TES material below (bottom) the oven. This arrangement helps to store thermal energy during peak sunlight hours and release it as needed to ensure continuous baking, providing a stable baking environment despite variations in solar intensity. And finally, there is transparent plastic cover on the top of open parabolic it acts as insulator to increase the performance of the oven. The schematic diagram of the baking system is shown in Figure 4.1.

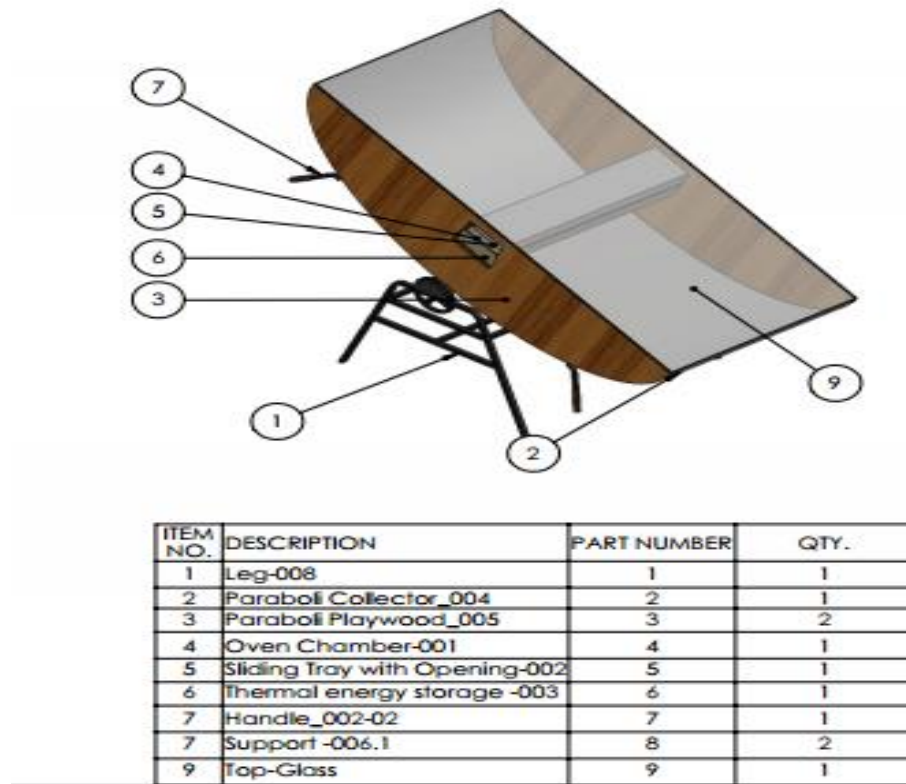

Figure 4.1 Schematic drawing of the system

4.2. Design Specifications of Solar Bread Baking System

This research looks at solar bread baking systems through experimental testing. The quantity of breads baked daily and the size of the baking tray closely correlate with the capacity of the bread baking oven. The average weight of bread dough taken into account for this analysis was 1.8 kg, from this amount of dough 20 piece of small rolled bread is baked which was determined by interviewing small-scale bakeries and gathering data. One batch of bread took 35 to 45 minutes to bake in a normal baking system depending on the size and type of bread and 45 to 60 minutes to bake in a solar thermal baking system (Falconí et al., 2019). The right temperature will ensure that the bread raise properly, develops a golden crust, and maintains a soft and fluffy interior. Preheating the oven is crucial for bread baking. It ensures that the oven reaches the desired temperature before you put in the dough, providing consistent heat from the start. The ambient temperature is 25 °C throughout this analysis (Sileshi et al., 2021)

4.2.1. Dough Preparation for Baking

In the bread baking experiments conducted for this study, each small dough bread are prepared by weighing 90 grams of dough per piece before baking. A total of 20 small breads are baked in each trial. The dough is prepared by mixing flour and water in a 2:1 ratio, a common practice in bakeries. For every 5 kg of flour, 2.5 liters (or 2.5 kg) of water are used, resulting in a water-to-flour ratio of 50%. This means that 33.33% of the total dough mass is composed of water. Therefore, out of the total 1.8 kg of dough, 600 grams is water, and the remaining 1.2 kg (1200 grams) consists of flour neglecting yeast and salt.

4.2.2. Impact of Water Content on Baking

The water content plays a crucial role in the baking process, as it contributes to the mass loss observed during baking due to evaporation. In this study, the typical mass loss of approximately 16% during bread baking, primarily due to water evaporation as reported by (Nicolas et al., 2017) is adopted as a reference value because it aligns with the physical processes observed in similar baking methods. . For a total dough mass of 1.8 kg, the estimated mass loss would be 288 grams. After baking the total mass of the 20 small breads is expected to be 1.512kg of bread product.

4.3. Energy Required for Bread Bakery

In Ethiopia, small bread typically weighs between 70 and 100 grams. For the purpose of this analytical study, a 90gram loaf will be considered, reflecting the weight of commonly available small rolled bread in the country. Bread is deemed fully baked when its core temperature reaches between 92°C and 95°C. Crust formation begins at 100°C as moisture on the surface starts to evaporate. However, at an altitude of 2,355 meters, such as that of Addis Ababa, the evaporation temperature decreases to 92°C. The browning of the crust, which signifies colorization, occurs at approximately 115°C.(Aragaw et al., 2022)

Bread baking is an energy-intensive process that requires sufficient energy to heat the dough to the desired temperature and evaporate the water lost during baking (e.g., latent heat of water vaporization is 2.26 MJ/kg at 100 °C). To calculate the energy required for bread baking, both the initial mass of the dough and the final mass of the baked bread are measured. The amount of water

vaporized can be determined by the difference between the initial dough mass and the final bread mass. To know the required energy for baking 20 rolls of bread we have to consider factors like: mass of bread, specific heat capacity of the bread, the temperature increase (difference) and also the baking time.

Mathematically, this baking energy is given by using specific heat formula in (Eq4.1): -

$$Q_{req} = m_{bread} * C_{p_{bread}} * (\Delta T) + Q_w \dots\dots\dots 4.1$$

Where, Q_{req} = useful energy required

m = mass of bread/dough

$C_{p_{bread}}$ = specific heat of bread/dough

ΔT = baking temperature minus initial temperature in kelvin

Q_w = energy required to evaporate water

The mass of bread in this study is 1.8kg of dough total and each 20 roll bread weights 90 gram for average family members per day and to small bakeries, the specific heat capacity of bread is approximately 2.7 kJ/kg °C (Zheleva et al., 2005) and the temperature increase is assuming the dough starts at room temperature (about 25 °C) and needs to be baked at 95°C then the temperature increase (ΔT) is 70 °C. To calculate the energy required plugs the value in the above formula.

$$Q_{req} = 1.8kg * 2.7 \frac{kJ}{kg} \text{ } ^\circ\text{C} * 70 \text{ } ^\circ\text{C}$$

$$Q_{req} = 340.2kJ$$

So, 340 kJ of energy is required to raise the temperature of the bread to the desired baking level. And the latent heat of vaporization is calculated in (Eq4.2)

$$Q_w = (m_{dough} - m_{bread}) h_v \dots\dots\dots 4.2$$

$$= (1.8kg - 1.512) 2260$$

$$= 650.88 kJ$$

There for the useful energy for bread baking is 991.08kJ . During the baking process, energy losses occur in the oven and thermal energy storage systems. To account for these losses and ensure adequate energy availability, a safety factor is applied. In thermal processes like baking, safety factors often range from 10–50% additional energy is planned to account for losses and inefficiencies. Considering these factors, a safety factor of 10% was selected the energy requirement to bake 20 small breads will be 1090.19kJ .

4.4. Oven Chamber Design

The largest quantity of bread the oven can bake at once will determine the volume of oven. The goal of the thesis is to develop a solar oven that can bake bread with a mass equivalent to 20 pieces of normal Ethiopian rolled bread, as nearly all rolled bread can only bake 90g dough of bread at a time and bread in nature usually rises up to 70mm during baking (Zheleva et al., 2005). In this study, the small bread considered for baking has a diameter of 80mm, a height of 70mm, and a weight of 90 grams before baking. These dimensions reflect the typical size of small bread commonly available in Ethiopia and are used as the standard for the experimental setup. The oven's internal height is designed to be at least 100mm to accommodate the size of the rolled bread. The oven is rectangular in shape, as this design is ideal for ensuring uniform heat distribution. The length and width are chosen to provide sufficient spacing between the bread rolls, allowing for proper airflow. The oven walls are constructed from aluminum sheet metal due to its excellent thermal conductivity. The oven's volume is estimated based on the size of the bread and allowing additional space for proper airflow. The dimension of the oven is $200\text{ mm} \times 100\text{ mm} \times 1000\text{mm}$, resulting in a total volume of $2 \times 10^7\text{ mm}^3$.

4.5. Thermal energy storage design

To effectively size the thermal energy storage (TES) system is crucial to ensure that the TES can store sufficient energy to maintain the required baking temperature even when direct solar input is unavailable as previously calculated 1288.404kJ of energy is needed to bake the 20 rolls of bread. The material for thermal storage is pebble bed b/c it has high thermal capacity and relatively low cost. The specific heat capacity of the pebble bed material is typically within the range of 0.7 to 0.9 kJ/kg °C (Kedida et al., 2019), as reported in studies on packed bed thermal energy storage systems. Usually, the specific heat capacity of the pebble bed is 0.84 kJ / kg °C and operating temperature ranges from 95°C to 25°C. The thermal storage medium is a packed pebble bed,

consisting of uniformly shaped spherical pebbles, chosen for its abundance and stable chemical and mechanical properties. The storage size is designed based on the energy demand required for the bread baking application and considering both solid volume of pebble bed and the air voids (porosity) in the storage bed as detailed below in (Eq4.3).

$$Q_{req} = \rho_{pebble\ bed} * C_{pebble\ bed} * v_{pebble\ bed} * (\Delta T) \dots\dots\dots 4.3$$

Where, Q=energy required (1090.19kJ)

$\rho_{pebble\ bed}$ = Density of pebble bed (in kg)

$C_{pebble\ bed}$ = Specific heat capacity of pebbles (0.84kJ/kg °C)(Kedida et al., 2019)

$v_{pebble\ bed}$ = Volume of pebbles

ΔT = Temperature difference (70°C)

Rearrange the formula adjusting for porosity solves in (Eq4.4);

$$v_{st} = \frac{v_{pebble\ bed}}{(1-\varepsilon)} \dots\dots\dots 4.4$$

Where, v_{st} = Total volume of TES

ε = Air void (porosity) for packed pebble bed ranges from 0.35 to 0.4 (Kedida et al., 2019; Okello et al., 2014). 0.38 is taken for the study of this paper because it is closed and random.

Substituting (Eq4.4) in the energy (Eq4.3)

$$Q_{req} = \rho_{pebble\ bed} * C_{pebble\ bed} * v_{st} (1 - \varepsilon) * (\Delta T) \dots\dots\dots 4.5$$

$$\begin{aligned} v_{st} &= \frac{Q_{req}}{\rho_{pebble\ bed} * C_{pebble\ bed} (1 - \varepsilon) * (\Delta T)} \\ &= \frac{1090.19kJ}{1600 * \frac{0.84kJ}{kg} \text{ } ^\circ\text{C} * (1 - 0.38) * 70^\circ\text{C}} \\ &= 1.87 * 10^7 \text{mm}^3 \end{aligned}$$

The volume of pebbles can be calculated by inserting the v_{st} value in (Eq4.4)

$$\begin{aligned}
 v_{pebble\ bed} &= v_{st} (1- \varepsilon) \dots\dots\dots 4.6 \\
 &= 1.87 * 10^7 mm^3 (1-0.38) \\
 &= 1.16 * 10^7 mm^3
 \end{aligned}$$

$$m_{pebble\ bed} = 1600 * 0.0116 = 18.56 \text{kg}$$

So, 18.56kg of pebble bed is needed to store the required heat energy for some hour. Density of pebble bed is typically around 1600kg/ m³(Duffie, 2013).

Assuming the length and width of the TES container are the same as the oven's dimensions (200mm x 1000mm), the width of TES container section is calculated in (Eq4.7):

$$\text{Volume} = \text{length} * \text{width} * \text{height} \dots\dots\dots 4.7$$

$$\text{Height} = \frac{\text{volume}}{\text{length} * \text{width}}$$

$$H = \frac{0.0187}{0.2 * 1} = 93.5 \text{mm}$$

$$V = 200 * 93.5 * 1000 \text{mm}^3$$

In Figure 4.2 below shows the schematic drawing of the oven integrated to the thermal energy storage (pebble bed).

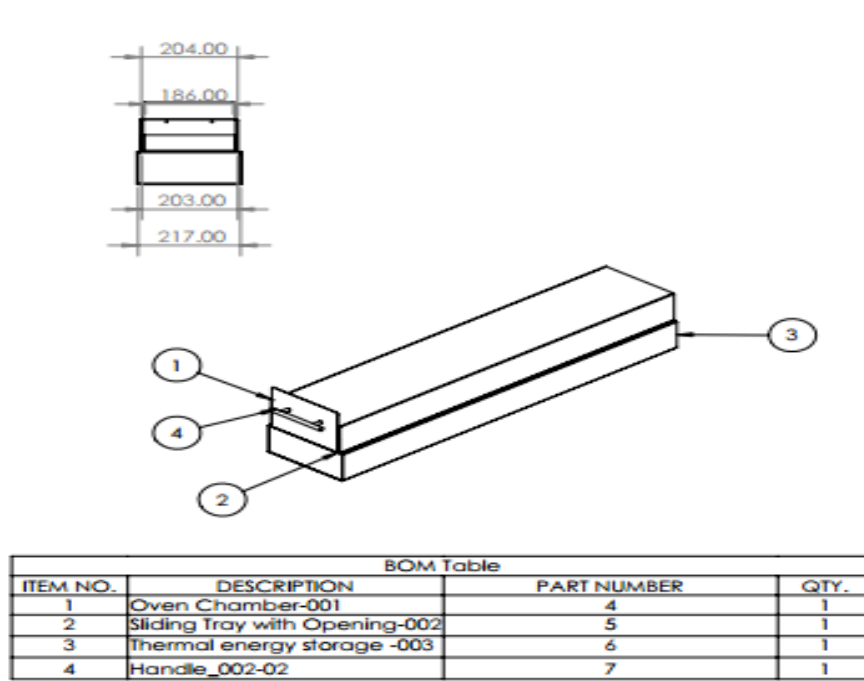

Figure 4.2 schematic drawing of the oven integrated with thermal energy storage

4.6. Parabolic Dish Concentrator Design

A Parabolic Trough Solar Collector (PTSC) is a type of concentrating solar collector that uses a parabolic-shaped reflector to focus sunlight onto a receiver. This design is particularly effective for applications that require high temperatures, such as baking, due to its ability to concentrate solar radiation onto a small area. The reflector material used for this study is silver coated aluminum because it has high reflective capacity. To increase the efficiency of the PTSC, a single-axis manual tracking system could be incorporated. This system allows the parabolic trough to follow the sun's movement throughout the day, maximizing solar energy capture. The analysis will consider the minimum annual average solar radiation in Addis Ababa, measured at 393 W/m²(Aragaw et al., 2022). Which gives us the energy available per square meter of collector surface Thus, to bake 20 pieces of normal small rolled bread in 50mins we will need a useful heat transfer of Q_u in (Eq4.8): -

$$Q_u = Q_{req}/t \dots\dots\dots 4.8$$

$$Q_u = 1090.19 \text{ kJ} / 50 \text{ min} * 60 = 363.4 \text{ W}$$

The required energy to bake 20 rolls of bread, $Q_u=1090.19kJ$, over a baking time of 50 minutes corresponds to an average power demand of approximately 363.4 W is needed for baking.

The useful energy output from a solar collector system is calculated as follow in (Eq4.9): -

$$Q_u = \eta * G * A_{ap} \dots\dots\dots 4.9$$

Where, Q_u =useful energy output in watt

η = efficiency of the solar collector.

G =solar radiation incident on the collector surface (in W/m²)

A_{ap} =aperture area of the solar collector (in m²)

$$A_{ap} = W * L \dots\dots\dots 4.9$$

Solar collector conversion efficiency (in the range of 40%-60%) =50% (Duffie, 2013; Padhy et al., 2021) and the aperture length is same as that of the oven length which is 1m and from the above formula the aperture width is substituting (Eq4.8 in Eq4.9):-

$$Q_u = \eta * G * W * L \dots\dots\dots 4.10$$

$$W = \frac{Q_u}{\eta * G * l} = \frac{363.4W}{0.6 * 393 * 1}$$

$W=1541mm$, then aperture area A_{ap} is $1.54 * 10^6 \text{ mm}^2$

The concentration ratio (C) of a parabolic trough collector is defined as the ratio of the aperture area to the receiver area. This concentration ratio indicates the degree to which the parabolic trough concentrates sunlight onto the receiver calculated as follow in (Eq4.11).

$$C = \frac{A_{aperture}}{A_{receiver}} \dots\dots\dots 4.11$$

$$C = \frac{A_{aperture}}{A_{receiver}} = \frac{1.54 * 10^6}{2 * 10^5} = 7.7$$

Calculating the Focal Length of the Parabolic Trough: -

The **focal length** (f) of a parabolic trough is a critical parameter that defines how sunlight is concentrated onto the receiver. For a parabolic reflector, the focal length is related to the aperture width and the depth of the parabola through in the following Figure 4.3.

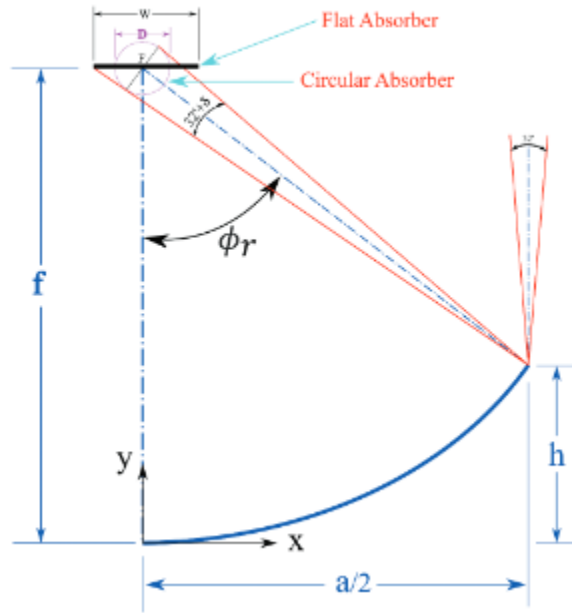

Figure 4.3 Parabolic trough collector geometry.(Shyam et al., 2021)

Thus, the acceptance half angle can be determined using equation 4.12: -

$$\theta_c = \sin^{-1}\left(\frac{1}{c}\right) = \sin^{-1}\left(\frac{1}{7.7}\right) = 7.5^\circ \dots \dots \dots 4.12$$

And, the focus will be calculated in (Eq4.13);

$$f = A_r * (1 + \sin \theta_c), \text{ where } A_r = 2 * 10^5 \text{ mm}^2 \dots \dots \dots 4.13$$

$$f = 226 \text{ mm}$$

Also, the depth of parabola can be calculated in (Eq4.14)

$$h = \frac{w^2}{16f} = 0, \text{ where } w = 1541 \text{ mm}$$

$$\text{Then, } h = \frac{(2185 \text{ mm})^2}{16 * 226 \text{ mm}} = 656.7 \text{ mm}$$

And, our parabolic equation will be; $x = \frac{w}{2}$

$$Y = \frac{X^2}{4f}, \text{ for } -770.5 < X < 770.5 \text{ mm for } 0 < Y < 656.7 \text{ mm}$$

The rim angle can be calculated using the formula:

$$\tan(\theta_r) = \frac{w}{4f} = 1.705$$

$$\theta_r = \tan^{-1}(1.705) = 59.6^\circ$$

In figure 4.4 below shows the schematic drawing of parabolic collector with all components.

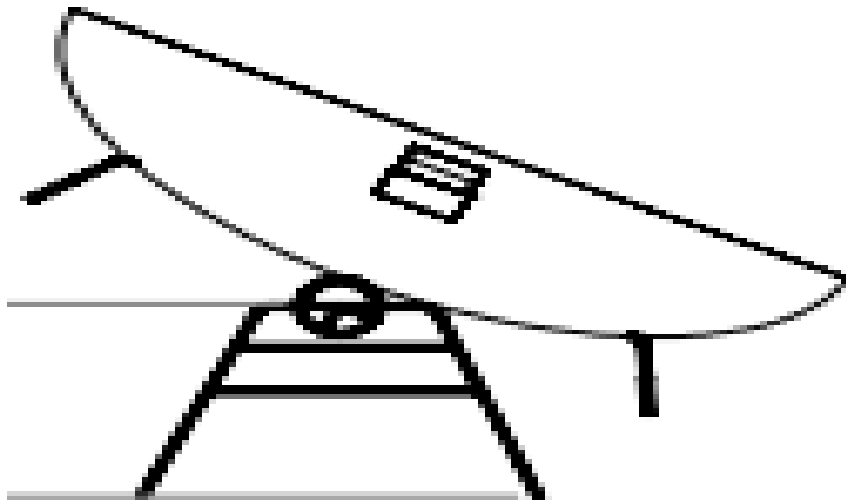

Figure 4.4 the schematic drawing of parabolic through collector with all components

4.7 Manufacturing steps

After completing the design phase of the solar bread baking oven integrated with thermal energy storage (TES), the system was fabricated according to the specified dimensions and design drawings. The main components manufactured include the parabolic trough collector, the receiver unit (oven and pebble bed (TES)), the poly wood, the acrylic glass cover and the support structure. The process involved cutting, bending, joining, sealing, riveting, drilling and assembling, using locally available materials and conventional workshop tools.

4.7.1 Receiver (Oven with TES) Construction

A rectangular box type oven was fabricated from aluminum sheet with a length of 1000mm, a width of 200mm, and a height of 193.5mm. The lower 93.5mm section was allocated for the thermal energy storage, which was filled with uniformly sized, washed, and dried river pebbles. The upper zone served as the baking chamber, with it's a sliding hinged door tray was installed at one end for inserting and removing bread samples. External surfaces of the oven painted black for improved heat absorption. Figure 4.5 below shows the oven manufacturing process and final oven image with TES.



A)

B)

C)



D)

E)



F)

G)

H)

I)

Figure 4.5 A-I manufacturing process of receiver oven integrated with (pebble bed) TES

4.7.2 Parabolic Trough Collector Fabrication

A parabolic shape with aperture area of $1.54 \times 10^6 \text{ mm}^2$ was traced using a ply wooden template designed based on the calculated focal length and aperture width. A galvanized aluminum sheet was cut and bent along the parabolic curve using the wooden mold. The shaped parabolic trough was mounted on a wood frame with proper support to maintain its curvature and orientation. Reflective aluminum foil was glued smoothly on the inner surface of the ply wood to enhance solar reflection and increase the concentration of sunlight toward the focal line. Figure 4.6 below shows the parabolic through collector manufacturing process.



A)

B)



C)

D)



(E)

Figure 4.6 A-E Manufacturing process of parabolic through collector

4.7.3 System Insulation and Sealing

Acrylic Glass insulation was applied to upper part of the opening parabola and the receiver box to reduce thermal losses. The front and back openings were sealed using plywood boards with thermal sealing material around the joints. High temperature silicon sealant was used to close all potential heat-leakage gaps, especially around the glazing. Figure 4.7 below shows the acrylic glass cover and the ply woods.

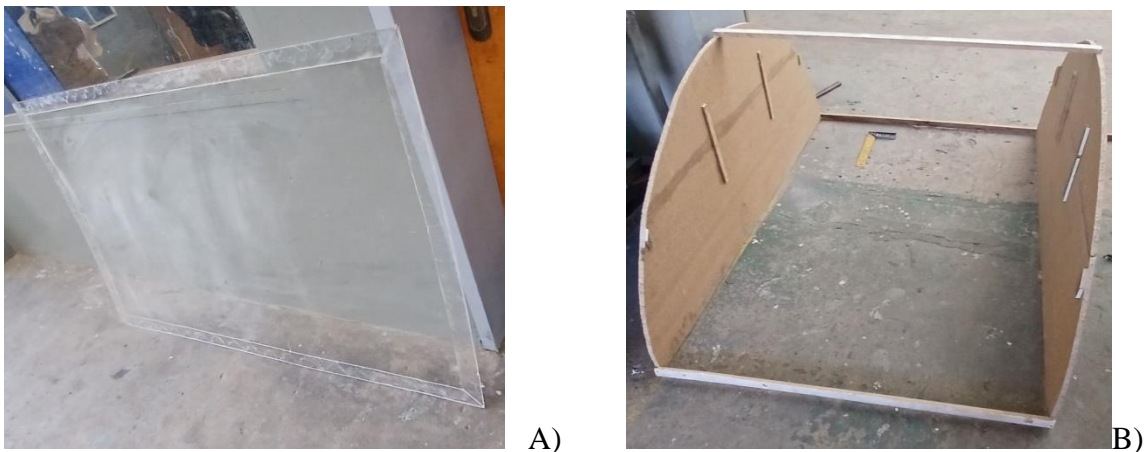

Figure 4.7 A) The acrylic glass cover and B) the ply woods as insulator and frame.

4.7.4 Integration and Final Assembly

The receiver box (oven + TES) was positioned precisely at the focal line of the parabolic trough to ensure maximum heat transfer. A stable metallic stand was fabricated to hold the parabolic trough at an adjustable tilt angle for optimal solar tracking. Thermocouples were installed at selected points inside the TES, oven chamber, and on bread surfaces for temperature monitoring during experiments. The fully assembled unit was tested for structural stability and alignment before proceeding to performance evaluation. This manufacturing process translated the theoretical design into a working prototype suitable for experimental testing and performance analysis under actual solar conditions. Figure 4.8 below shows the assembled image of the prototype.



A)



B)



C)



D)



E)



F)



G)



H)

Figure 4.8 Manufacturing processes of the components, different view of the oven and extraction of the Patra and final assembly image of oven

4.8 Experimental setup

The experimental setup is composed of a parabolic trough solar collector coupled with a direct solar bread baking oven integrated with a pebble bed thermal energy storage system. The receiver, which houses both the baking chamber and the thermal storage, is positioned along the focal line

of the trough to absorb concentrated solar radiation. To enhance heat capture, additional aluminum foil is added to the inside part of ply wood. A transparent glazing cover is installed above to minimize heat loss while permitting solar radiation to enter. The system includes a National Instruments data logger (NI DAQ-9211) connected to four thermocouples placed at critical locations within the oven two places, for ambient temperature and TES. These sensors continuously monitor temperature variations during the charging and baking phases. The data logger is interfaced with a computer for real time data acquisition and storage, enabling detailed analysis of the thermal performance. The oven is insulated with plywood enclosures on the front and back, with one end serving as sliding tray with door for inserting and removing bread. This arrangement allows for direct solar baking during the day and continued baking using the stored heat after solar input declines. Figure 4.9 experimental setup of the system.

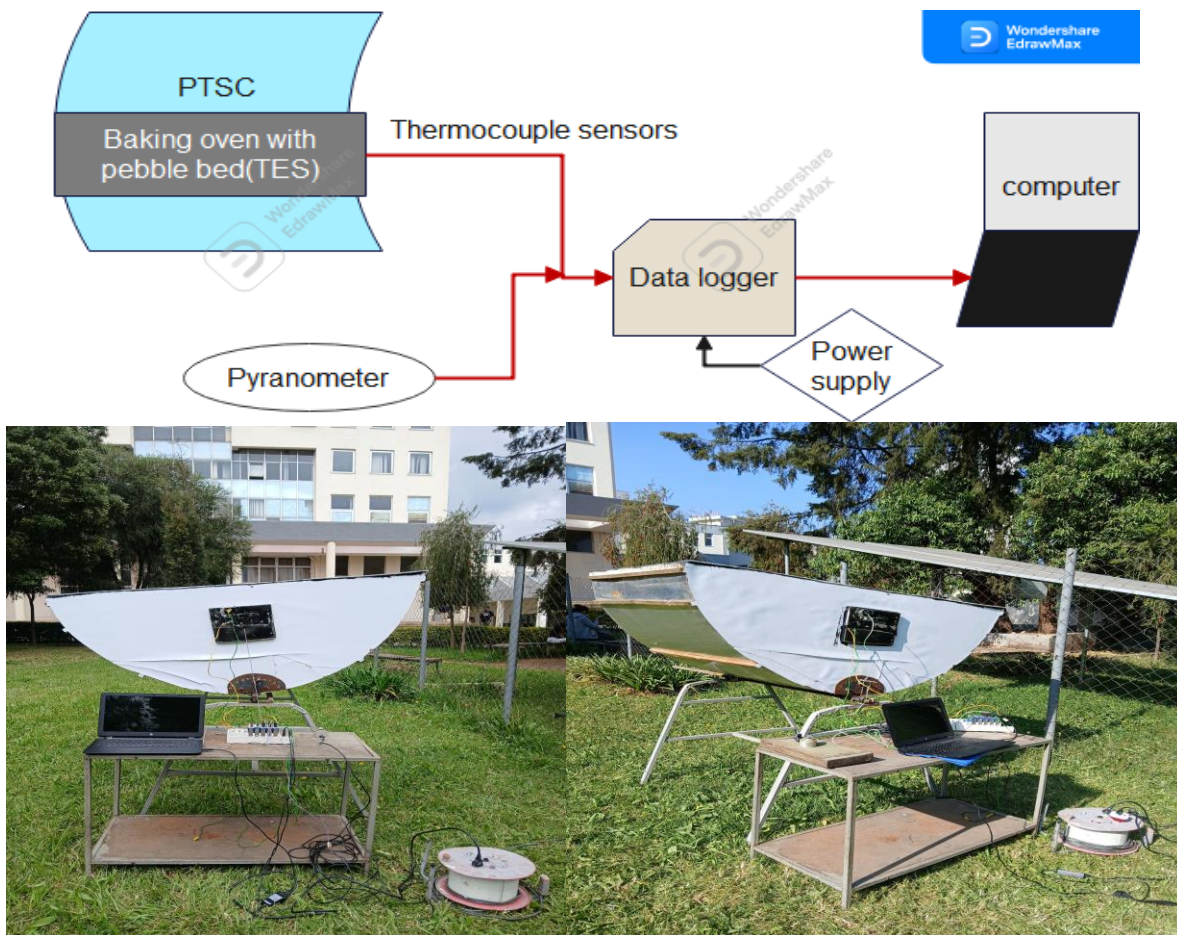

Figure 4.9 experimental setup

CHAPTER FIVE

RESULT AND DISCUSSION

5.1. No-load test analysis

The no-load test was conducted to evaluate the maximum attainable temperature of the solar bread baking oven under direct solar radiation without any load inside the oven. This test provides insight into the oven's thermal performance in terms of heat retention and energy accumulation capability. During the test, the oven was exposed to sunlight from the start of the day, and temperature readings were recorded at regular intervals using thermocouples placed at strategic points within the oven. The ambient temperature and solar irradiance were also monitored to correlate environmental conditions with oven performance. The oven temperature was observed to gradually increase and eventually stabilize, reaching its stagnation temperature. This peak temperature indicates the oven's maximum thermal potential under idle conditions. The preheating time, defined as the duration required for the oven to reach a temperature suitable for baking, was also recorded. These findings are critical for determining the oven's readiness and efficiency before actual baking operations begin.

The first no load test was performed on October 23, 2025 from 12:00pm to 13:50 pm the weather was partly sunny and the solar radiation was fluctuating it was not smooth (stable). The maximum oven air temperature gained from this test was 97.5°C and the ambient temperature range was 23°C the average solar radiation through testing hour was $701.13\text{w}/\text{m}^2$. In figure 5.1 shows the first temperature variation and solar radiation vs time test result graph.

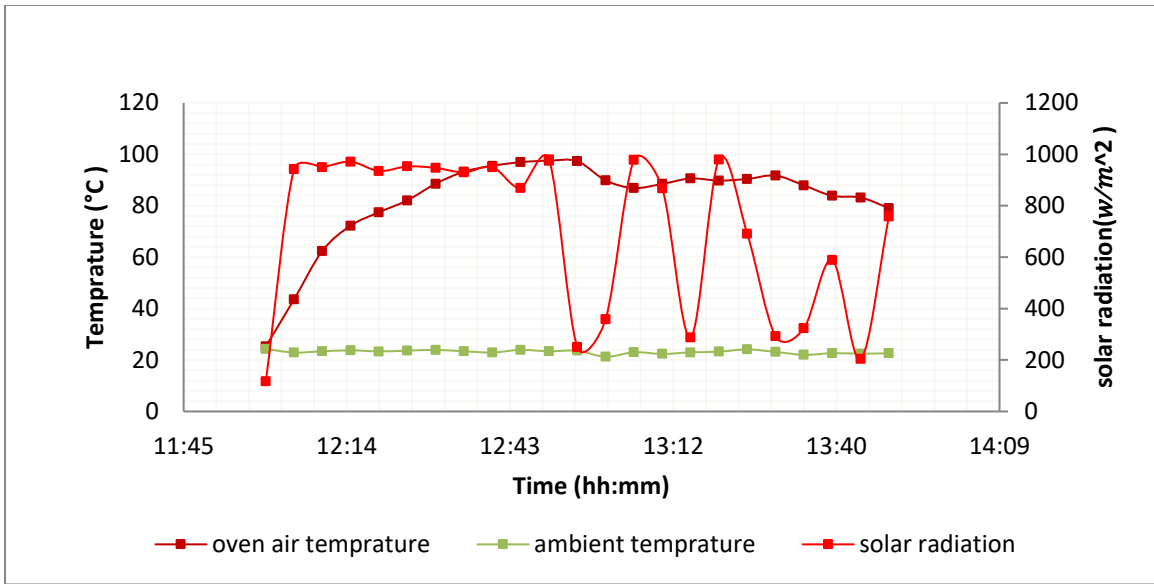

Figure 5.1 temperature variation and solar radiation vs time graph for first no load test

the second no load test was recorded on October 24, 2025 from 10:20 AM to 13:35PM the weather condition was partly cloudy the maximum oven air temperature was gained 81.8°C and the TES (pebble bed) temperature was 90°C and the average ambient temperature and solar radiation during the testing hour was 23°C and 698.6 w/m^2 . In figure 5.2 shows second temperature variation and solar radiation vs time test result graph.

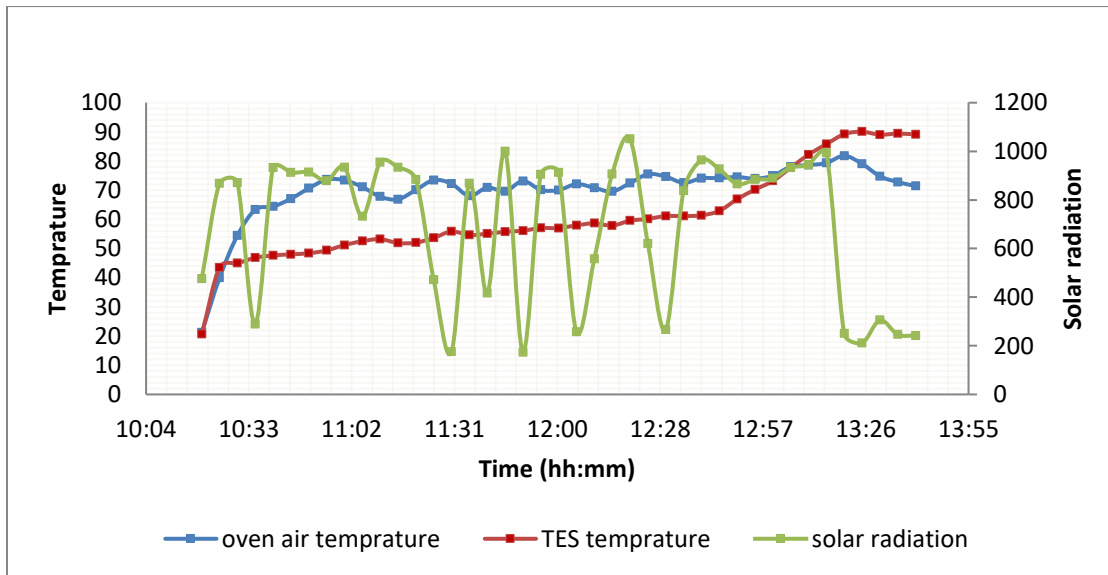

Figure 5.2 temperature variation and solar radiation vs time graph for second on no load test result

The third no load test was performed on October 28, 2025 in AAiT campus the weather was partly cloudy and the solar radiation was no stable through testing hour. During the test the maximum oven air, plate, pebble bed temperature was and the average ambient and solar radiation was 93°C,103 °C,87 °C and 26°C and 832 w/m^2 . In figure 5.3 shows second temperature variation and solar radiation vs time test result graph.

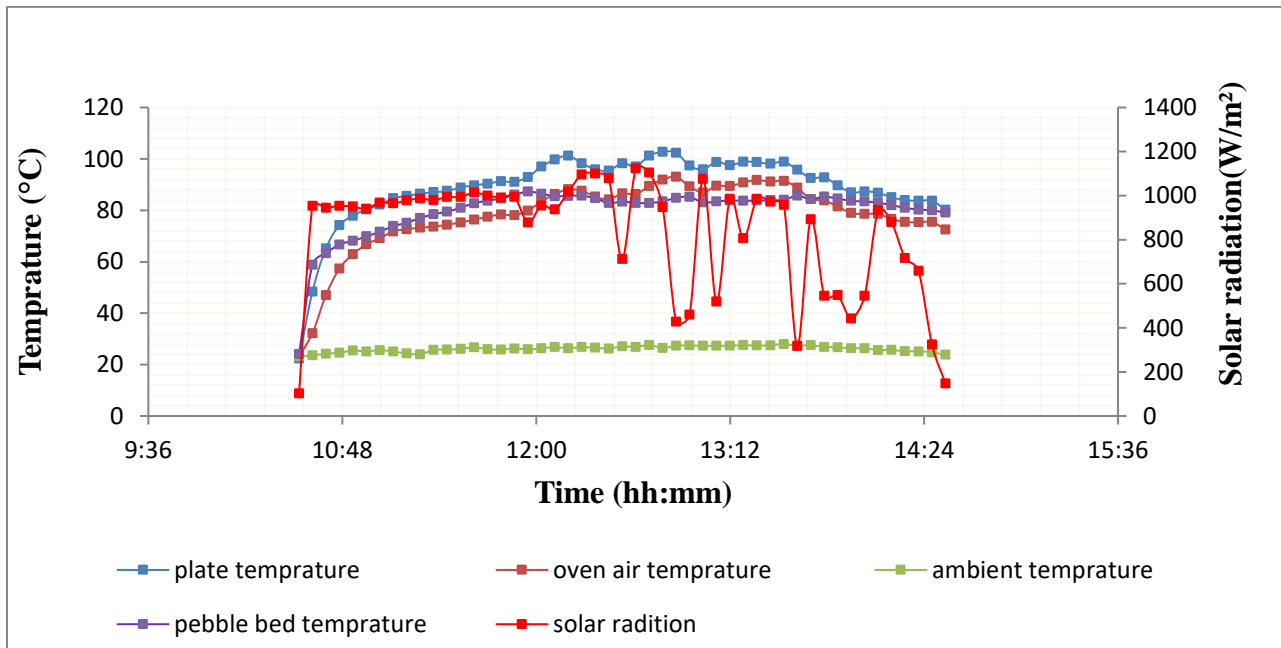

Figure 5.3 temperature variation and solar radiation vs time graph for third on no load test

5.2 Bread baking test analysis

The bread baking test was carried out to evaluate the practical performance of the solar bread baking oven under actual working conditions. The objective was to assess the oven’s capability to bake bread effectively and determine its utilization efficiency. During the test, a known mass of dough was placed inside the preheated oven, and temperature readings were recorded at five-minute intervals. Key parameters monitored included the core temperature of the bread, oven air temperature, pebble bed temperature, ambient temperature and solar radiation at the time of testing. Thermocouples were inserted into the center of the bread and connected to the data acquisition system to ensure accurate temperature tracking. The test was repeated on three different sunny days to validate the consistency and reliability of the results. The bread was considered fully

baked when the core temperature reached the desired level (typically around 92°C to 98°C). The time required to complete the baking process, along with variations in oven temperature, were analyzed to evaluate the thermal responsiveness and efficiency of the system. The results confirmed the solar oven’s effectiveness in achieving the necessary baking temperature and producing evenly baked bread without the use of conventional fuel.

5.2.1 Sample bread baking test

In figure 5.4 Shows the first sample bread baking test result different temperature and solar radiation vs time graph. The first sample test was conducted on November 3, 2025 at 10:31AM to 13:31PM in AAiT campus the weather condition is mostly cloudy and the solar radiation was not stable it fluctuates the maximum oven air temperature, bread core temperature and the pebble bed temperature for this test were 89.3°C, 76.8°C, and 71.3°C and also the average ambient temperature and solar radiation was 23.5°C and 640.584. w/m^2 . As the image shown in below the bread was well baked.

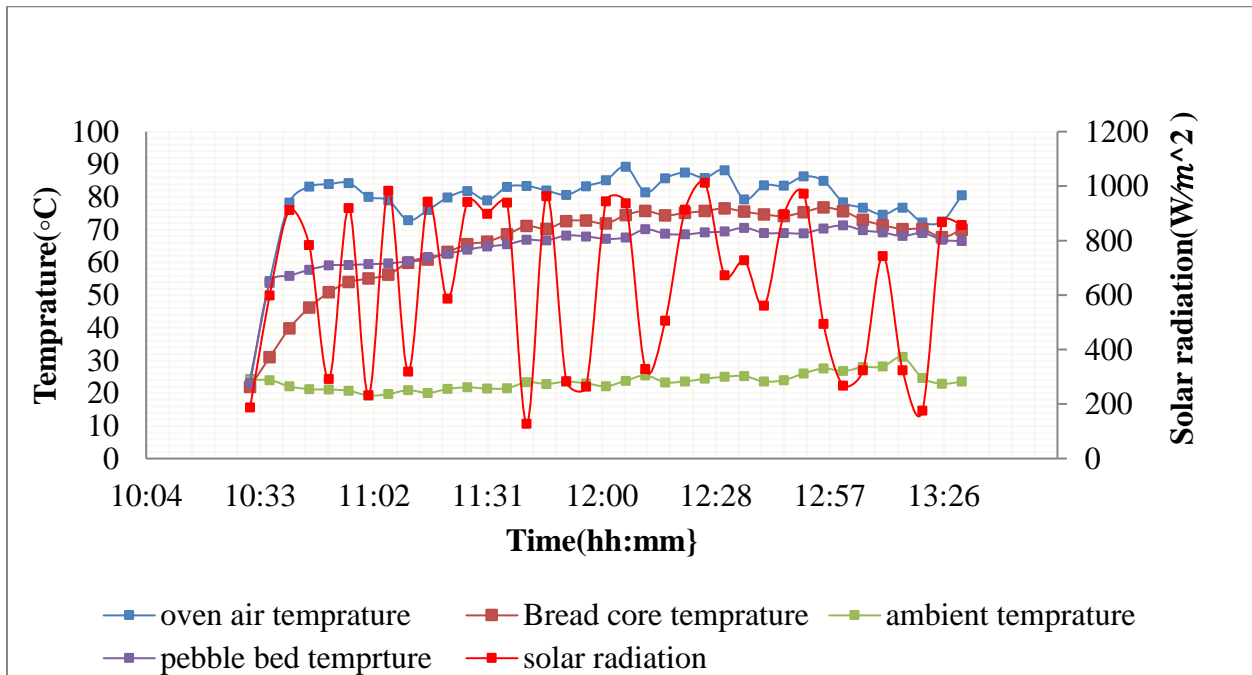



A) Before baking

B) after baking

Figure 5.4 temperature variations, solar radiation vs time graph and sample bread baking first test result

In figure 5.5 shows the second sample bread baking test result it was conducted on November 4, 2025 at 13:17 PM to 15:27 PM. The test was performed in AAiT campus the weather condition was partly cloudy and the solar radiation was not stable the same as the first sample bread baking test condition. From this test the maximum oven air temperature, bread core temperature and the pebble bed temperature were 87.5°C, 67.4°C and 72.9°C and also the average ambient temperature and the solar radiation was 24.6°C and 431.1. w/m^2 . The bread was baked and also it was increase in height after baking.

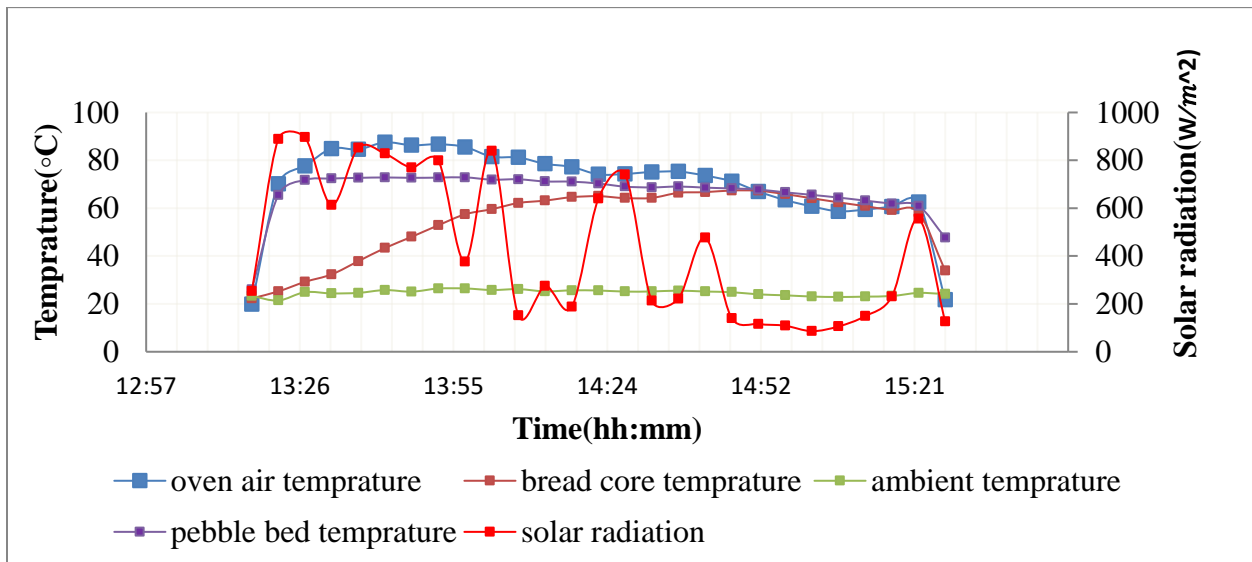

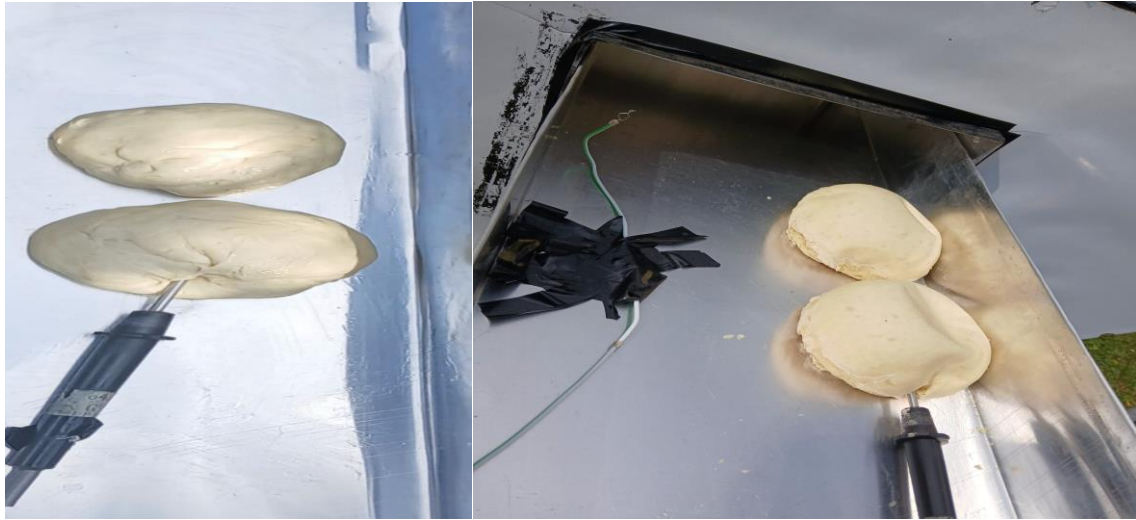

A) Before baking

B) after baking

Figure 5.5 temperature variations, solar radiation vs time graph and sample bread baking second test result

In figure 5.6 the third sample bread baking test was performed on November 7, 2025 at in AAiT campus the weather is mostly cloudy it is not stable the maximum oven air, bread core and pebble bed temperature were recorded it was gained 101.4°C, 81.9°C and 79.3°C and also the average ambient temperature and the solar radiation was 24.8°C and 673 w/m^2 . In this test the bread was well baked inside and out side also the color and its height also good.

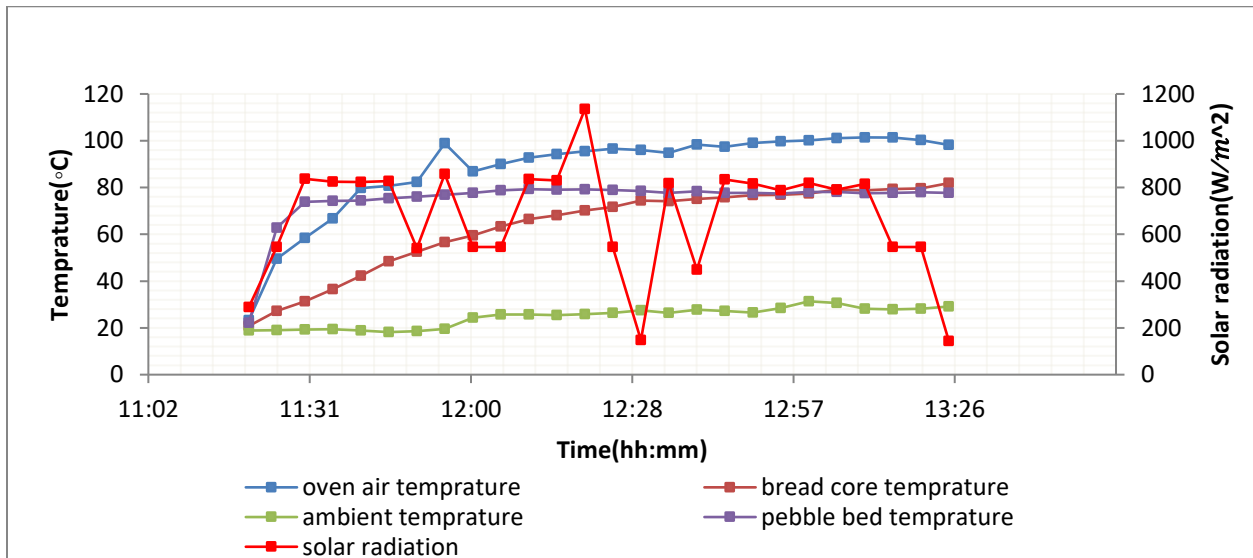



A

B

C

Figure 5.6 temperature variations, solar radiation vs time graph and sample bread baking third test result

5.2.2 Full bread baking test result

The first full load test was performed in AAiT campus on November 10, 2025 the weather condition was partly cloudy the test started at 11:20Am and ends at 14:20Pm it takes two hours for baking. The maximum oven air, bread core and pebble bed temperature were 80.5°C, 73.8°C and 76.6°C and also average ambient and solar radiation was 25°C and 822w/m². In figure 5.7 shows the different temperature and solar radiation vs time graph and the bread image before and after baking.

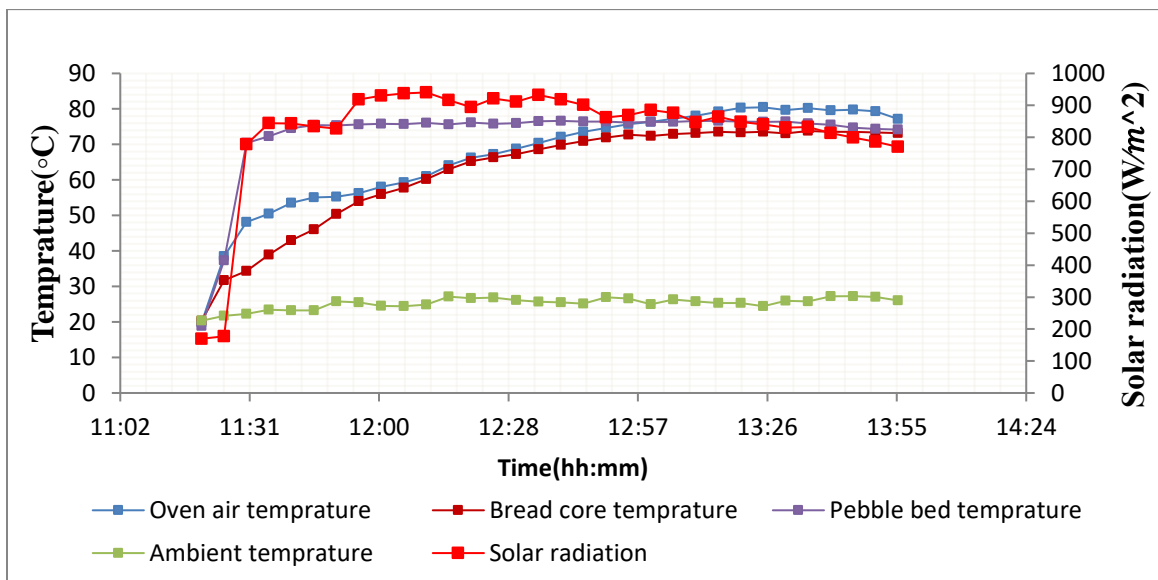



A

B

C

Figure 5.7 temperature variations, solar radiation vs time graph and full bread baking first test result

The second bread test was performed in AAiT campus on November 11, 2025 the weather is clear but it was windy the maximum bread core, oven air and pebble bed temperature gained were 77.3°C, 89.7°C and 75.9°C and also the average solar radiation and ambient temperature was 807.5w/m² and 25°C. In figure 5.8 Shows different temperature value and solar radiation during testing time and also the image of bread before and after baking.

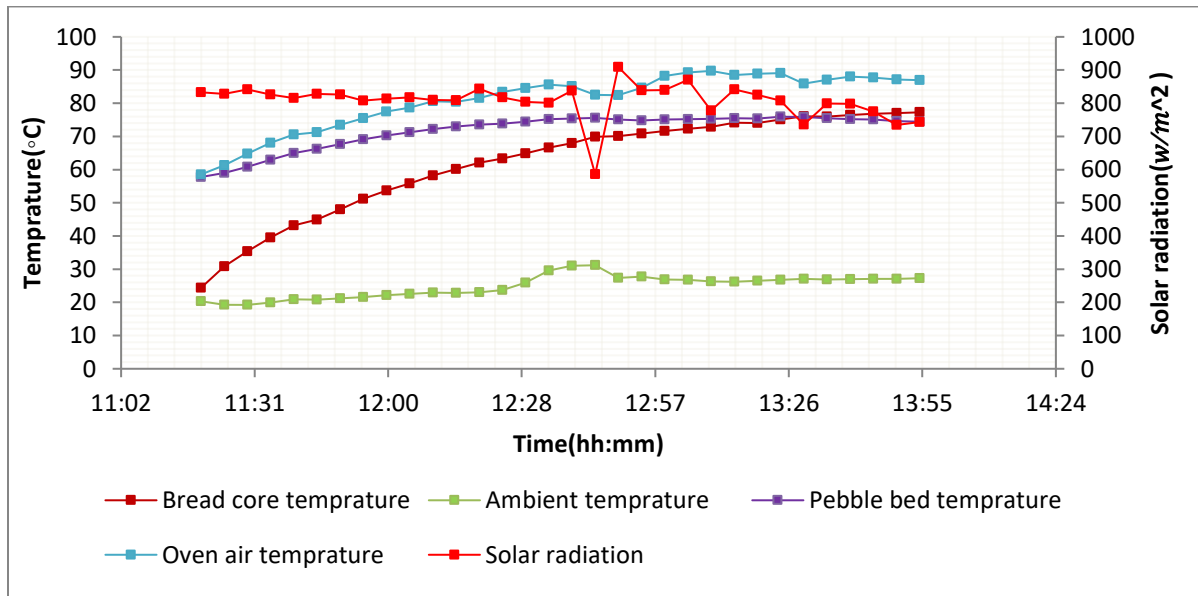

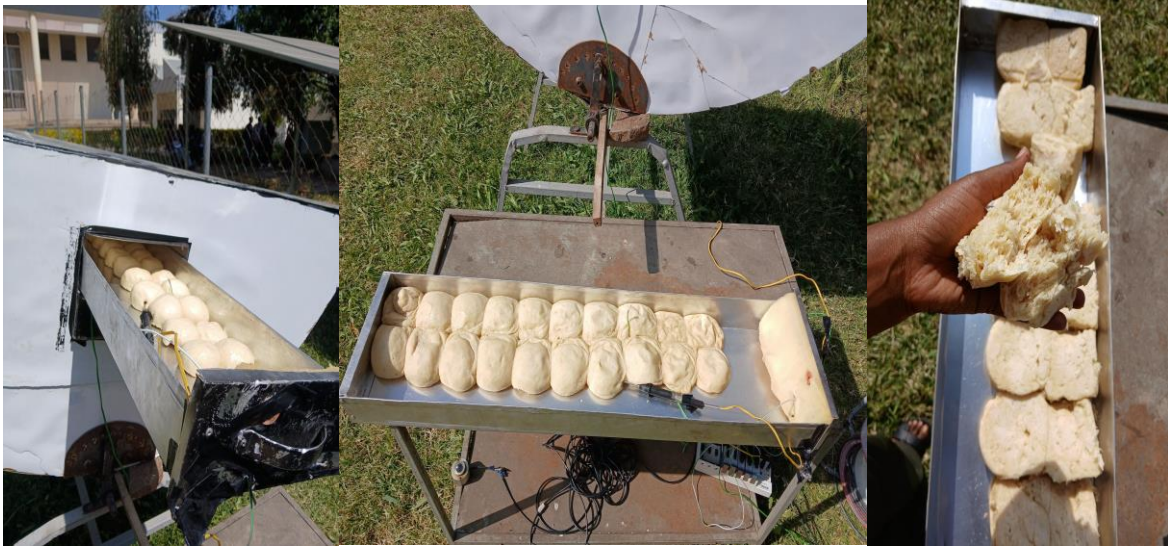

Figure 5.8 temperature variations, solar radiation vs time graph and full bread baking test second result

The third full bread test was performed on November 12, 2025 from 11:22Am to 14:02 Pm in AAiT campus the weather condition was mostly cloudy and fluctuates. the maximum oven air temperature, bread core temperature and pebble bed temperature were 97.4°C, 77.7°C, 73.2°C and also the average ambient temperature and solar radiation was 26°C and 611.6w/m². In figure 5.9 shows the varies temperature and solar radiation vs time graph and also the bread before and after baking.

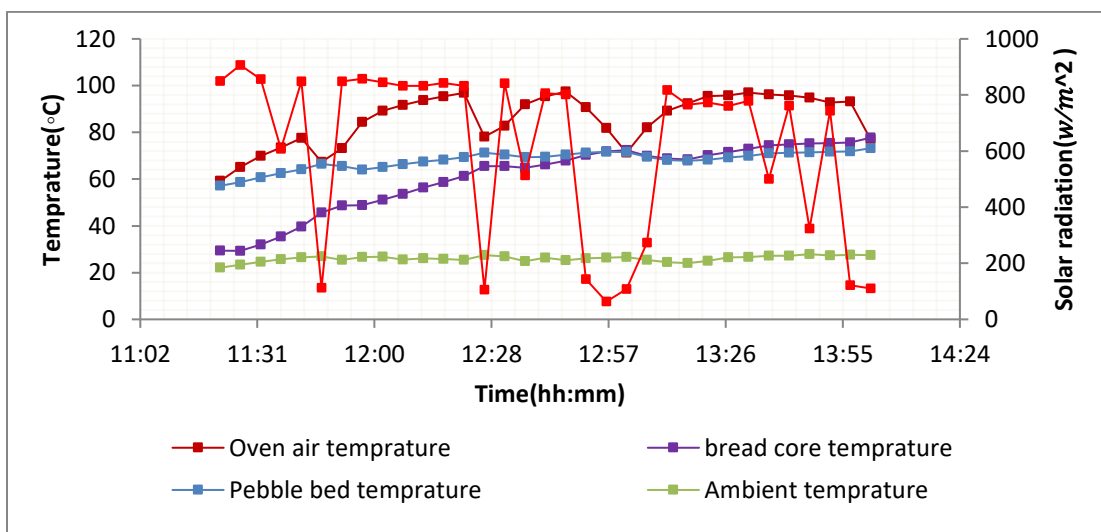



Figure 5.9 temperature variations, solar radiation vs time graph and full bread baking third test result

5.3 performance evaluation of the solar bread baking oven

5.3.1 Thermal efficiency of the oven

Thermal efficiency of the oven is used for measuring the performance of the oven that transmit the heat of the oven to the bread it measures the performance of the oven that bake the bread. The formula for thermal efficiency is the useful energy divided by the incident energy of the collector calculated in (Eq5.1): -

$$\eta_{th} = \frac{m_b c_b (T_f - T_i)}{I A_{ap} \Delta t} \dots\dots\dots 5.1$$

Where, m_b =mass of bread

c_b =specific heat capacity of bread

T_f =final temperature of bread

T_i =initial temperature of bread

I =average solar radiation

A_{ap} =aperture area

Δt =time taken

By using equation 5.1 above calculated the thermal efficiency for the three testing days was gained 2.6%, 3.5% and 2.96 %.

5.3.2 First figure of merit (F1)

First figure of merit indicates that the stagnation temperature of oven under no load test and the formula for this was in (Eq5.2): -

$$F1 = \frac{T_{p_{max}} - T_{am}}{I} \dots\dots\dots 5.2$$

Where, F1 is first figure of merit

$T_{p_{max}}$ is maximum air temprature

T_{am} Is Average Ambient temperature

I =average solar radiation

By using equation 5.2 first figure of merit for the three no load testing days was calculated and gained 0.107, 0.084, and 0.08.





5.4 Discussions

Experimental testing of the parabolic bread baking oven with pebble bed thermal energy storage was tested in AAiT campus in Addis Ababa, Ethiopia on different testing days to check the continuity of the baking oven but most of the day the weather condition was not comfortable it was fluctuating do to that it affects the performance of the bread baking oven. The weight was reduced by 10-12 gram from each piece of bread on different testing days. After finishing the test for all the tests, the bread was tested by different people about 10 persons tested the bread and their comment was good they said it was baked well unless its color not become brown the inside part of the bread was baked.

Different researchers study about this area by theoretically and also by experimentally and get different thermal efficiency based on their type, shape and size of reflective material ,based on different weather condition with stable and fluctuating condition and also by testing different types of food with different mass weight do to this all factors the performance of the solar cooker (baker)

was affected. In table 5.1 shows comparison of bread profile after baking, stagnation temperature, first figure of merit and their initial mass.

Table 5.1 comparison of bread profile after baking and their mass

Title	Bread profile	Mass of bread	$T_{stagnation}$	F1 first figure of merit	reference
Design, Simulation, Manufacturing and Testing of A Low-Cost Tube Type Direct Solar Oven		1kg	127°C	0.158	(Aragaw et al., 2022)
Development and Performance Evaluation of a Solar Baking Oven		–	121°C	0.1204	(B. Y. Mekonnen et al., 2020)
Development of solar baking oven with sensible heat storage	 <p data-bbox="488 1255 737 1276">Figure 6a: Dough of bread before baking</p>  <p data-bbox="500 1402 725 1423">Figure 6b: Loaf of bread after baking</p>	150kg	96.75°C	–	(Ajayi et al., 2023)
Experimental Investigation of Concentrating Solar Baker Using Parabolic Trough Solar Collector Integrated with Thermal Energy Storage		2.1 kg,	100°C	–	(Abate, 2021)

Experimental
Investigation
of
Concentrated
Solar Bread
Baking Oven
Integrated with
Thermal
Energy
Storage
(Pebble bed)



1.8kg

101°C

0.107

This study
work

CHAPTER SIX

CONCLUSION AND RECOMMENDATION

CONCLUSION

This study successfully designed and experimentally tested a parabolic trough solar bread-baking oven integrated with a pebble-bed thermal energy storage system. The main objective was to evaluate its ability to bake bread using only solar energy under natural weather conditions. The system achieved oven air temperatures of up to 101°C and bread core temperatures up to 81°C, showing that the concept is functional even under fluctuating solar radiation this is due to the thermal energy storage (pebble bed).

The thermal performance analysis indicated that the oven's thermal efficiency ranged from 2.6% to 3.5%, which is within the expected range for early-stage experimental solar baking systems. The first figure of merit also showed moderate performance, mainly influenced by heat losses and unstable weather during testing. Despite these limitations, the oven was able to bake 20 pieces of small bread during each test, and user feedback confirmed that the bread was properly baked internally. The purpose of thermal energy storage (pebble bed) was to keep the heat of the oven not to drop gradually this is because of keeping the quality of bread that bread needs consistent heat energy.

The results demonstrate that a solar bread baking oven with thermal energy storage can contribute to reducing biomass fuel consumption and can be a potential clean-cooking solution for rural communities mainly. The system is simple, low-cost, and uses locally available materials, making it suitable for further development and community adoption.

RECOMMENDATION

Based on the experimental findings, the following recommendations are made:

- ❖ Improve insulation and sealing: -Enhancing insulation around the oven and minimizing air leakage can reduce heat loss and improve thermal efficiency.

- ❖ Increase optical efficiency: -Adding higher reflectivity materials or improving the alignment of the parabolic trough may help increase the heat input to the oven.
- ❖ Use a selective absorber coating: -Painting the receiver with a high-absorptivity, low-emissivity coating can increase heat absorption and reduce radiative losses.
- ❖ Conduct extended tests in stable weather: -Repeating the experiments during days with consistent sunlight may provide clearer performance results.
- ❖ Explore design modifications for browning: -Adding a transparent top cover with higher transmissivity or incorporating a secondary reflector may help increase radiant heat for browning the bread surface.
- ❖ Further community-based trials: -Testing the system with households in rural areas especially in desert area can provide practical insights for scaling up and improving user acceptance.
- ❖ Integrate the system with power source where the electric city is available.
- ❖ Also improving the manually tracking system to increase the baking capacity.

REFERENCE

- Abate, S. G. (2021). *Experimental Investigation of Concentrating Solar Baker Using Parabolic Trough Solar Collector Integrated with Thermal Energy Storage*. Adama Science and Technology University,
- Abbood, M. H., & Mohammed, M. M. (2019). Experimental characteristic of a solar parabolic trough collector with indirect steam generation system. *International Journal of Energy and Environment*, 10(2), 87-96.
- Abed, N., & Afgan, I. (2020). An extensive review of various technologies for enhancing the thermal and optical performances of parabolic trough collectors. *International Journal of Energy Research*, 44(7), 5117-5164.
- Adem, K. D., & Ambie, D. A. (2017). A review of injera baking technologies in Ethiopia: Challenges and gaps. *Energy for Sustainable Development*, 41, 69-80.
- Adem, K. D., Ambie, D. A., Arnavat, M. P., Henriksen, U. B., Ahrenfeldt, J., & Thomsen, T. P. (2019). First injera baking biomass gasifier stove to reduce indoor air pollution and fuel use. *AIMS Energy*, 7(2), 227–245.
- Ajayi, A. B., Adisa, M. B., Openibo, A. O., & Anike, V. U. (2023). Development of solar baking oven with sensible heat storage
- ACTA TECHNICA CORVINIENSIS – Bulletin Of ENGINEERING.*
- Alva, G., Lin, Y., & Fang, G. (2018). An overview of thermal energy storage systems. *Energy*, 144, 341-378.
- Aragaw, Y. T., & Adem, K. D. (2022). Development and performance evaluation of tube-type direct solar oven for baking bread
- 8.
- Aremu, A. K., & Igbeka, J. C. (2015). Energetic and exergetic evaluation of box-type solar cookers using different insulation materials. *World Acad Sci Eng Technol Int J Biol Biomol Agric Food Biotechnol Eng*, 9, 462-468.
- Asfafaw Haileselassie Tesfaya, M. B. K., & O. J. N. (2014). Solar powered heat storage for Injera baking in Ethiopia. 57, 1603 – 1612
- Ayub, I., Munir, A., Ghafoor, A., Amjad, W., & Nasir, M. S. (2018). Solar Thermal Application for Decentralized Food Baking Using Scheffler Reflector Technology.
- Badran, A. A., Yousef, I. A., Joudeh, N. K., Al Hamad, R., Halawa, H., & Hassouneh, H. K. (2010). Portable solar cooker and water heater. *Energy Conversion and Management*, 51(8), 1605-1609.
- Bakehe, N. P., & Hassan, R. (2023). The effects of access to clean fuels and technologies for cooking on deforestation in developing countries. *Journal of the Knowledge Economy*, 14(3), 2561-2577.
- Balzar, A., Stumpf, P., Eckhoff, S., Ackermann, H., & Grupp, M. (1996). A solar cooker using vacuum-tube collectors with integrated heat pipes. *solar energy*, 58(1-3), 63-68.
- Benti, N. E., Gurmesa, G. S., Argaw, T., Aneseyee, A. B., Gunta, S., Kassahun, G. B., . . . Asfaw, A. A. (2021). The current status, challenges and prospects of using biomass energy in Ethiopia. *Biotechnology for Biofuels*, 14, 1-24.
- Berhanu, M., Jabasingh, S. A., & Kifile, Z. (2017). Expanding sustenance in Ethiopia based on renewable energy resources—A comprehensive review. *Renewable and Sustainable Energy Reviews*, 75, 1035-1045.

- Chattopadhyay, M. (2024). A Review of the Literature on the Economics of Household Air Pollution from Solid Fuel Usage. *Energy Transitions and Climate Change Issues in Asia*, 221-241.
- Chen, C., Sharma, A., Tyagi, S., & Buddhi, D. (2008). Numerical heat transfer studies of PCMs used in a box-type solar cooker. *renewable energy*, 33(5), 1121-1129.
- Duffie, J. A., & Beckman, W. A. . (2013). *Solar engineering of thermal processes* (4th ed.): wiley.
- El-Sebaei, A., & Ibrahim, A. (2005). Experimental testing of a box-type solar cooker using the standard procedure of cooking power. *renewable energy*, 30(12), 1861-1871.
- Eshetu, S. (2024). Fuelwood From Natural Forests' Contribution to Households' Energy Use and Its Effect on Carbon Dioxide Emission in Delanta District, Northeastern Ethiopia. *International Journal of Forestry Research*.
- Falconí, C. E., & Yáñez-Mendizábal, V. (2019). Solar UV-B radiation limits seedborne anthracnose infection and induces physiological and biochemical responses in *Lupinus mutabilis*. *Plant Pathology*, 68(9), 1635-1644.
- Forsythe, H. D. M., & Madyira, D. M. (2019). Experimental performance assessment of a solar powered baking oven. 35, 535-540.
- Gautam, A., & Saini, R. (2020). A review on sensible heat based packed bed solar thermal energy storage system for low temperature applications. *solar energy*, 207, 937-956.
- GTZ and DME. (2002b). Solar cooker compendium. *Scarcity of Household Energy and the rationale of solar cooking*.GTZ, Pretoria., 1.
- Harmim, A., Belhamel, M., Boukar, M., & Amar, M. (2010). Experimental investigation of a box-type solar cooker with a finned absorber plate. *Energy*, 35(9), 3799-3802.
- Hussein, H., El-Ghetany, H., & Nada, S. (2008). Experimental investigation of novel indirect solar cooker with indoor PCM thermal storage and cooking unit. *Energy Conversion and Management*, 49(8), 2237-2246.
- IEA. (2021). World Energy Outlook 2021,IEA,paris. *Internatinal Energy Agency*. Retrieved from <https://www.iea.org/reports/world-energy-outlook-2021>
- IEA. (2022). World Energy Outlook 2022. *Paris: International Energy Agency*,.
- Joshi, S. B., & Jani, A. (2015). Design, development and testing of a small scale hybrid solar cooker. *solar energy*, 122, 148-155.
- Kajumba, P. K., , D. O., , K. N., & , O. J. N. (2020). Experimental investigation of a cooking unit integrated with thermal energy storage system. 32.
- Kakoko, L. D., Jande, Y. A. C., & Kivevele, T. (2023). Experimental investigation of soapstone and granite rocks as energy-storage materials for concentrated solar power generation and solar drying technology. *ACS omega*, 8(21), 18554-18565.
- Kalogirou, S. A. (2003). The potential of solar industrial process heat applications. *Apply Energy*, 76, 337–361.
- Kalogirou, S. A. (2004). Solar thermal collectors and applications. *Progress in Energy and Combustion Science*, 30, 231-295.
- Kedida, D. K., Amibe, D. A., & Birhane, Y. T. (2019). Performance of a pebble bed thermal storage integrated with concentrating parabolic solar collector for cooking. *Journal of Renewable Energy*, 2019(1), 4238549.
- Kedir, M. F., Bekele, T., & Feleke, S. (2019). Problems of Mirt, and potentials of improved Gonzie and traditional open cook stoves in biomass consumption and end use emission in rural wooden houses of Southern Ethiopia. *Scientific African*, 3, e00064.
- Knudson, B. (2004). State of the art of solat cooking: A global survey of practices and promotion programs. *SCI, Sacramento*.
- Kojima, M. (2021). Primary household energy for cooking and heating in 52 developing economies.

- Kumaresana, G., V. S. V., S. E., & R. V. (2016). Performance assessment of a solar domestic cooking unit integrated with thermal energy storage system. *6*, 70-79.
- Laaraba, A., & Mebarki, G. (2020). Enhancing thermal performance of a parabolic trough collector with inserting longitudinal fins in the down half of the receiver tube. *Journal of Thermal Science*, *29*, 1309-1321.
- Mahavar, S., Sengar, N., Rajawat, P., Verma, M., & Dashora, P. (2012). Design development and performance studies of a novel single family solar cooker. *renewable energy*, *47*, 67-76.
- Maina, M. B., Ngala, G. M., & Abdulrahim, A. T. (2016). Design, Fabrication and Performance Evaluation of Solar Brick Oven. *Engineering Research & Technology (IJERT)*, *5*.
- Marif, Y., Benmoussa, H., Bouguettaia, H., Belhadj, M. M., & Zerrouki, M. (2014). Numerical simulation of solar parabolic trough collector performance in the Algeria Saharan region. *Energy Conversion and Management*, *85*, 521-529.
- Mazman, M., Cabeza, L. F., Mehling, H., Nogues, M., Evliya, H., & Paksoy, H. Ö. (2009). Utilization of phase change materials in solar domestic hot water systems. *renewable energy*, *34*(6), 1639-1643.
- Mekonnen, B. A., Liyew, K. W., & Tigabu, M. T. (2020). Solar cooking in Ethiopia: Experimental testing and performance evaluation of SK14 solar cooker. *Case Studies in Thermal Engineering*, *22*.
- Mekonnen, B. Y., & Kebede, A. Y. (2020). *Development and Performance Evaluation of a Solar Baking Oven*. Paper presented at the Advances of Science and Technology: 7th EAI International Conference, ICAST 2019, Bahir Dar, Ethiopia, August 2–4, 2019, Proceedings 7.
- Mirdha, U., & Dhariwal, S. (2008). Design optimization of solar cooker. *renewable energy*, *33*(3), 530-544.
- Mohamed, S. A., Al-Sulaiman, F. A., Ibrahim, N. I., Zahir, M. H., Al-Ahmed, A., Saidur, R., . . . Sahin, A. (2017). A review on current status and challenges of inorganic phase change materials for thermal energy storage systems. *Renewable and Sustainable Energy Reviews*, *70*, 1072-1089.
- Muthusivagami, R., Velraj, R., & Sethumadhavan, R. (2010). Solar cookers with and without thermal storage—a review. *Renewable and Sustainable Energy Reviews*, *14*(2), 691-701.
- Nagarajan, S., Barshilia, H., & Rajam, K. (2010). *Review of sputter deposited mid- to high- temperature solar selective coatings for Flat Plate/Evacuated tube collectors and solar thermal power generation applications*.
- Nhamo, G., Nhamo, S., Nhemachena, C., & Nhemachena, C. R. (2020). Africa and the 2030 sustainable energy goal: a focus on access to renewables and clean fuels for cooking. *Scaling up SDGs Implementation: Emerging Cases from State, Development and Private Sectors*, 39-57.
- Nicolas, V., Glouannec, P., Ploteau, J.-P., Salagnac, P., & Jury, V. (2017). Experiment and multiphysic simulation of dough baking by convection, infrared radiation and direct conduction. *International Journal of Thermal Sciences*, *115*, 65-78.
- Okello, D., Foong, C. W., Nydal, O. J., & Banda, E. J. (2014). An experimental investigation on the combined use of phase change material and rock particles for high temperature (~ 350 C) heat storage. *Energy Conversion and Management*, *79*, 1-8.
- Østergaard, P. A., Duic, N., Noorollahi, Y., Mikulcic, H., & Kalogirou, S. (2020). Sustainable development using renewable energy technology. In (Vol. 146, pp. 2430-2437): Elsevier.
- Osterman, E., Tyagi, V., Butala, V., Rahim, N. A., & Stritih, U. (2012). Review of PCM based cooling technologies for buildings. *Energy and Buildings*, *49*, 37-49.
- Padhy, A., Vishal, B., Verma, P., Dwivedi, G., & Behura, A. (2021). Fabrication of parabolic trough hybrid solar PV-T collector using a-Si thin film solar cells in Indian perspective. *Materials Today: Proceedings*, *38*, 56-62.
- Pata, U. K. (2025). How to progress towards sustainable development by leveraging renewable energy sources, technological advances, and human capital. *renewable energy*, 122367.

Schwarzer, K., & Da Silva, M. E. V. (2003). Solar cooking system with or without heat storage for families and institutions. *solar energy*, 75(1), 35-41.

Sedighi, M., & Zakariapour, M. (2014). A review of direct and indirect solar cookers. *Sustainable Energy*, 2(2), 44-51.

Sharma, A., Tyagi, V. V., Chen, C. R., & Buddhi, D. (2009). Review on thermal energy storage with phase change materials and applications. *Renewable and Sustainable Energy Reviews*, 13(2), 318-345.

Shyam, A., Iniyan, S., & Goic, R. (2021). Optical performance enhancement in a solar parabolic trough collector with optimized secondary optics. *Energy Sources, Part A: Recovery, Utilization, and Environmental Effects*, 1-18.

Sileshi, S. T., Hassen, A. A., & Adem, K. D. (2021). Drying kinetics of dried injera (dirkosh) using a mixed-mode solar dryer. *Cogent Engineering*, 8(1), 1956870.

Tadesse, M. (2020). The developmental patterns of injera baking stoves: review on the efficiency, and energy consumption in Ethiopia. *Int. J. Mech. Eng*, 7(1), 7-16.

Tavakoli, M., FarimaniMohsen, ZahraeiAli, & Kianifar, F. (2022). Novel Method to Design and Construction a Dual-Purpose Solar Oven

for Baking Bread.

Tesfay, A. H., Hagos, F. Y., Yohannes, K. G., Nydal, O. J., & Kahsay, M. B. (2015). Preparing side charging of PCM storage: theoretical and

experimental investigation.

Tesfay, A. H., Kahsay, M. B., & Nydal, O. J. (2019). Numerical and experimental analysis of solar injera baking with a PCM heat storage. *Momona Ethiopian Journal of Science*, 11(1), 1-13.

Tesfay, A. H., Kahsay, M. B., & Nydal, O. J. (2019). Numerical and experimental Analysis of Solar Injera Baking with a PCM Heat Storage 11.

Wassie, S. B. (2020). Natural resource degradation tendencies in Ethiopia: a review. *Environmental Systems Research*, 33. doi:<https://doi.org/10.1186/s40068-020-00194-1>

WHO. (2024). Household air pollution and health. In.

Zheleva, I., & Kambourova, V. (2005). Identification of heat and mass transfer processes in bread during baking. *Thermal Science*, 9(2), 73-86.

Appendix

Schematic drawing of all parts of the parabolic through solar collector bread baking oven integrated with thermal energy storage (pebble bed) with Solid work

ITEM NO.	DESCRIPTION	PART NUMBER	QTY.
1	Leg-008	1	1
2	Paraboli Collector_004	2	1
3	Paraboli Plywood_005	3	2
4	Oven Chamber-001	4	1
5	Sliding Tray with Opening-002	5	1
6	Thermal energy storage -003	6	1
7	Handle_002-02	7	1
7	Support -006.1	8	2
9	Top-Glass	9	1

	NAME	DATE	MATERIAL			
DRN	NAME			TOLERANCE	MATERIAL	FINISH
CHD	NAME					
APPD	NAME					
PROJECTION	SCALE	IDENTIFICATION NUMBER	TITLE:-EXPERIMENTAL INVESTIGATION OF CONCENTRATED SOLAR BREAD BAKING OVEN INTEGRATED WITH THERMAL ENERGY STORAGE			
	1:20	0001				

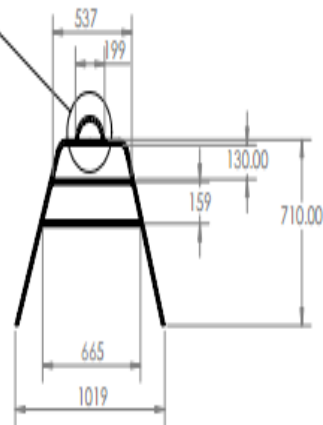
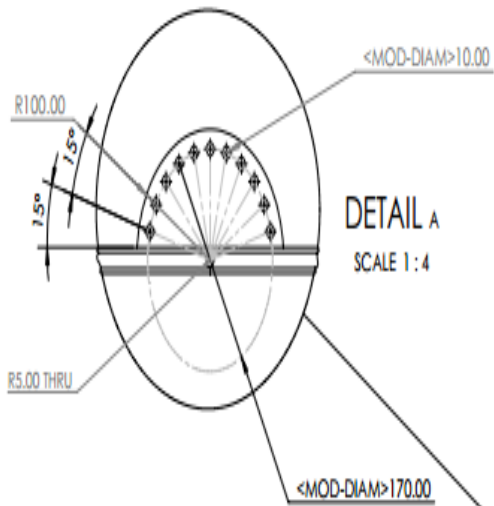

DRN	NAME	DATE	MATERIAL	TOLERANCE	MATERIAL	FINISH
CHD	YODIT SHIMELS	DEC				
APPD	DR,KAMIL D.	DEC				
PROJECTION		SCALE	IDENTIFICATION NUMBER	TITLE: SUPPORT LEG THE TERM "SUPPORT LEG" TYPICALLY REFERS TO A STRUCTURAL ELEMENT THAT PROVIDES STABILITY AND SUPPORT TO A LARGER STRUCTURE OR OBJECT.		
		1:50	0003			

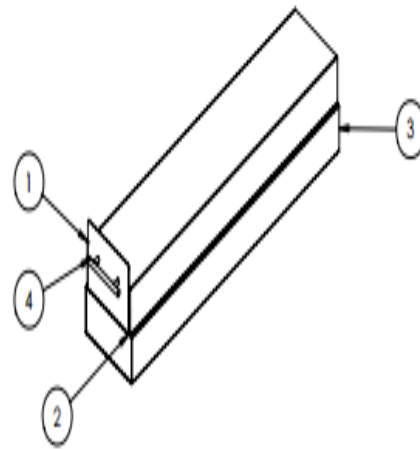
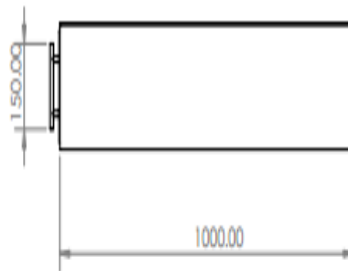
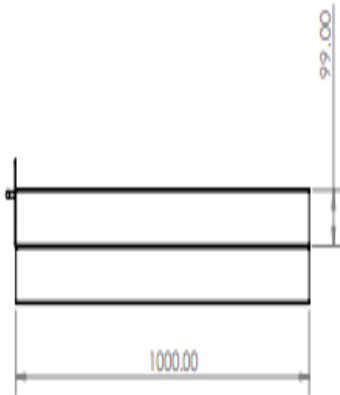

BOM Table			
ITEM NO.	DESCRIPTION	PART NUMBER	QTY.
1	Oven Chamber-001	4	1
2	Sliding Tray with Opening-002	5	1
3	Thermal energy storage -003	6	1
4	Handle_002-02	7	1

	NAME	DATE	MATERIAL	TOLERANCE	MATERIAL	FINISH
DRN	YODIT SHIMELS GETACHEW	DEC-2024	GC			
CHD	DR KAMIL DINO ADEM			TITLE: OVEN		
PROJECTION		SCALE	IDENTIFICATION NUMBER			
		1:50	0001			

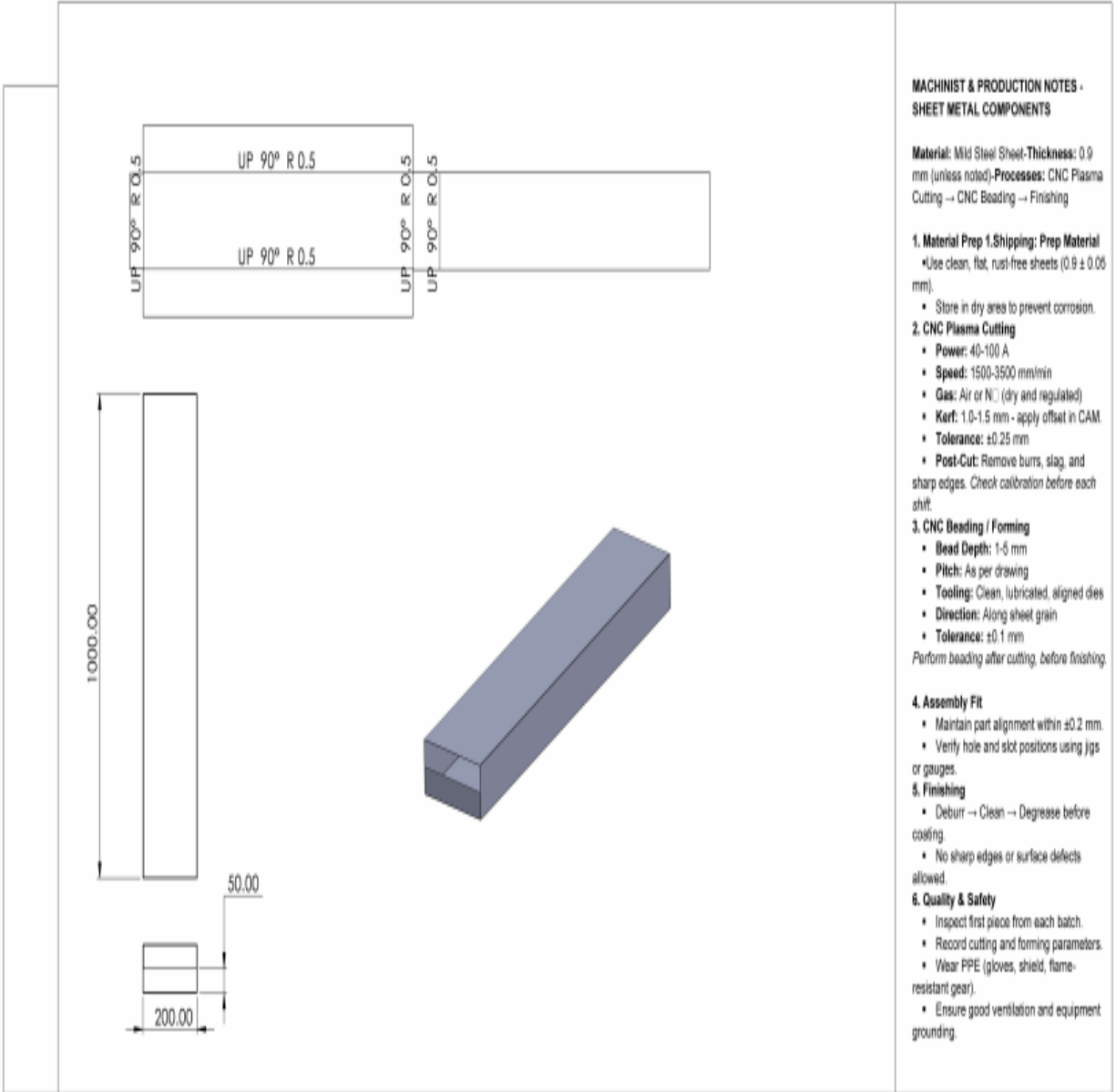

DR-BY-YODIT SHIMELS	SIZE	RECEIVER (OVEN BODY)..... ALUMINUM SHEET	NAME :-YODIT SHIMELS ID NO:- 1184/14 ADVISER NAME:- KAMIL DINO ADEM(PHD) TITLE:-EXPERIMENTAL INVESTIGATION OF CONCENTRATED SOLAR BREAD BAKING OVEN INTEGRATED WITH THERMAL ENERGY STORAGE
CH-BY-KAMIL DINO ADEM(PHD)	MM		
DRAWING SCALE (FOR DESIGN & BLUEPRINT)1:8			
PROJECTION		QTY-1	

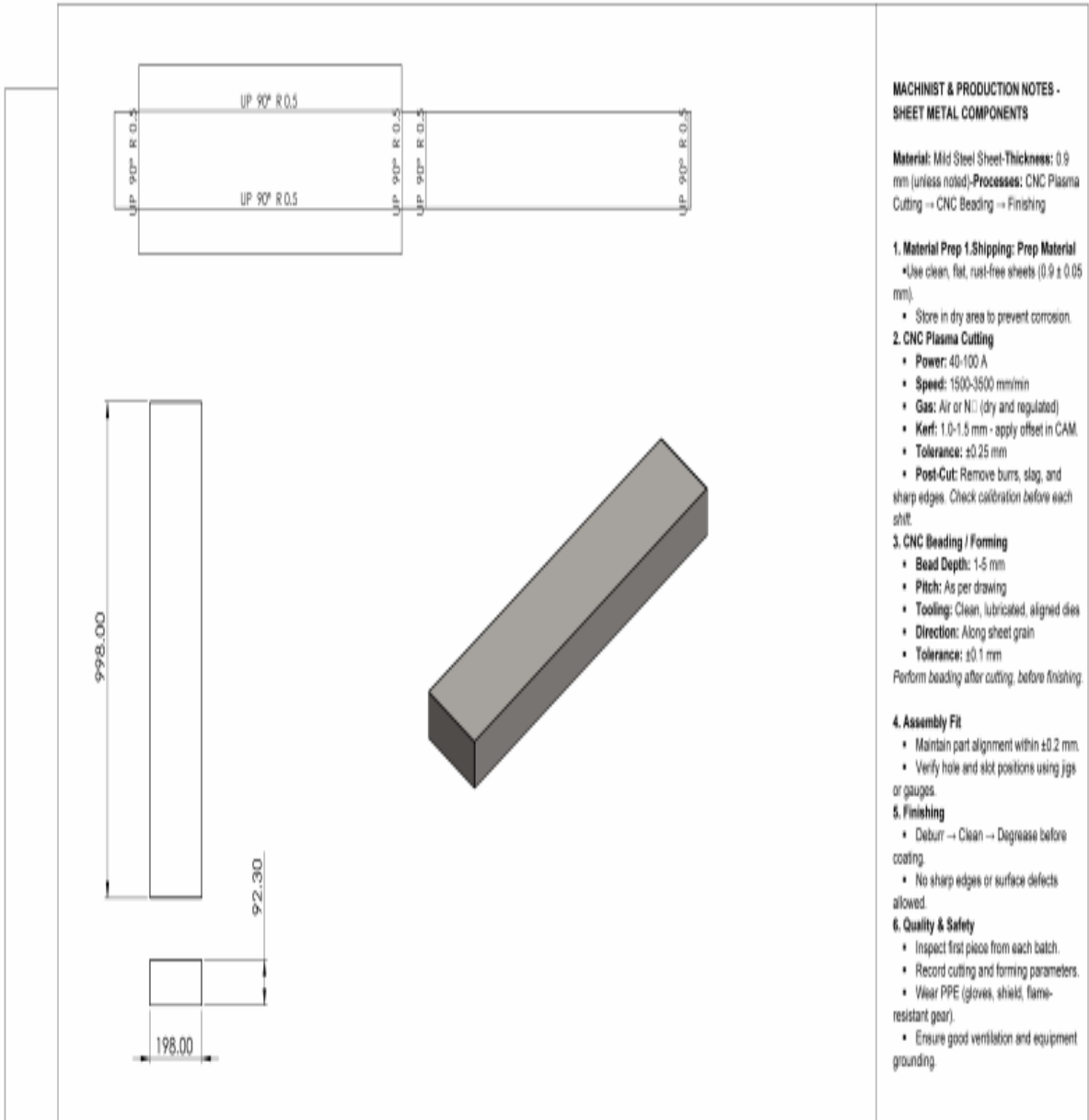

MACHINIST & PRODUCTION NOTES - SHEET METAL COMPONENTS

Material: Mid Steel Sheet-Thickness: 0.9 mm (unless noted)-**Processes:** CNC Plasma Cutting → CNC Beading → Finishing

1. Material Prep 1.Shipping: Prep Material

- Use clean, flat, rust-free sheets (0.9 ± 0.05 mm).

2. CNC Plasma Cutting

- **Power:** 40-100 A
- **Speed:** 1500-3000 mm/min
- **Gas:** Air or N₂ (dry and regulated)
- **Kerf:** 1.0-1.5 mm - apply offset in CAM.
- **Tolerance:** ±0.25 mm
- **Post-Cut:** Remove burrs, slag, and sharp edges. Check calibration before each shift.

3. CNC Beading / Forming

- **Bead Depth:** 1-5 mm
- **Pitch:** As per drawing
- **Tooling:** Clean, lubricated, aligned dies
- **Direction:** Along sheet grain
- **Tolerance:** ±0.1 mm

Perform beading after cutting, before finishing.

4. Assembly Fit

- Maintain part alignment within ±0.2 mm.
- Verify hole and slot positions using jigs or gauges.

5. Finishing

- Deburr → Clean → Degrease before coating.
- No sharp edges or surface defects allowed.

6. Quality & Safety

- Inspect first piece from each batch.
- Record cutting and forming parameters.
- Wear PPE (gloves, shield, flame-resistant gear).
- Ensure good ventilation and equipment grounding.

DR-BY-YODIT SHIMELS	SIZE	TITLE:- THERMAL ENERGY STORAGE (TES)...PEBBLE BED	NAME :-YODIT SHIMELS ID NO:- 1184/14 ADVISER NAME:- KAMIL DINO ADEM(PHD) TITLE-EXPERIMENTAL INVESTIGATION OF CONCENTRATED SOLAR BREAD BAKING OVEN INTEGRATED WITH THERMAL ENERGY STORAGE
CH-BY-KAMIL DINO ADEM(PHD)	MM		
DRAWING SCALE (FOR DESIGN & BLUEPRINT) 1:8			
PROJECTION		QTY-1	

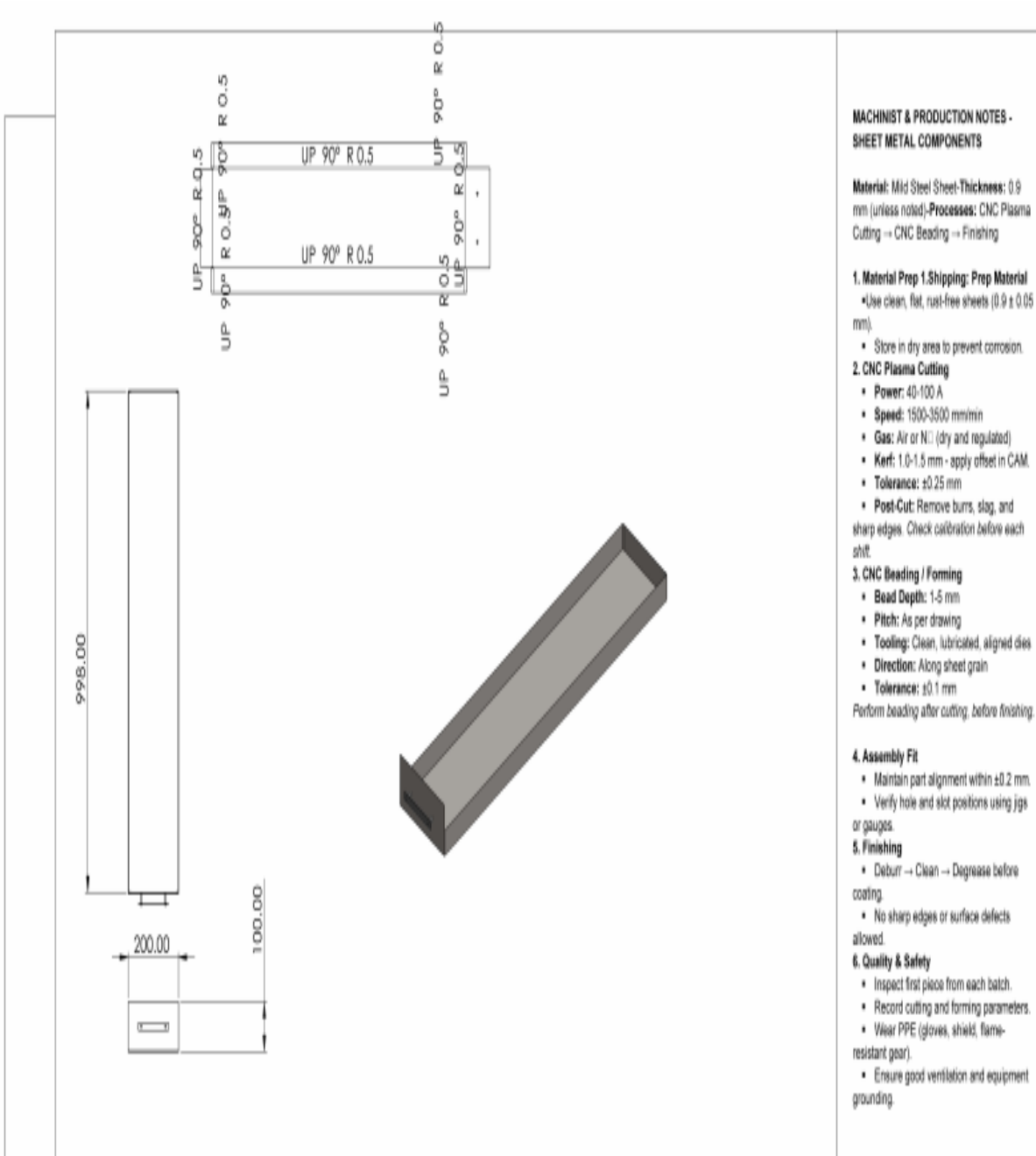

MACHINIST & PRODUCTION NOTES - SHEET METAL COMPONENTS

Material: Mild Steel Sheet-Thickness: 0.9 mm (unless noted)-**Processes:** CNC Plasma Cutting → CNC Beading → Finishing

1. Material Prep 1.Shipping: Prep Material
 • Use clean, flat, rust-free sheets (0.9 x 0.05 mm).
 • Store in dry area to prevent corrosion.

2. CNC Plasma Cutting
 • Power: 40-100 A
 • Speed: 1500-3500 mm/min
 • Gas: Air or N₂ (dry and regulated)
 • Kerf: 1.0-1.5 mm - apply offset in CAM.
 • Tolerance: ±0.25 mm
 • Post-Cut: Remove burrs, slag, and sharp edges. Check calibration before each shift.

3. CNC Beading / Forming
 • Bead Depth: 1-5 mm
 • Pitch: As per drawing
 • Tooling: Clean, lubricated, aligned dies
 • Direction: Along sheet grain
 • Tolerance: ±0.1 mm
 Perform beading after cutting, before finishing.

4. Assembly Fit
 • Maintain part alignment within ±0.2 mm.
 • Verify hole and slot positions using jigs or gauges.

5. Finishing
 • Deburr → Clean → Degrease before coating
 • No sharp edges or surface defects allowed.

6. Quality & Safety
 • Inspect first piece from each batch.
 • Record cutting and forming parameters.
 • Wear PPE (gloves, shield, flame-resistant gear).
 • Ensure good ventilation and equipment grounding.

DR-BY-YODIT SHIMELS	SIZE	SLIDING-TRAY WITH OPENING	NAME :-YODIT SHIMELS ID NO:- 1184/14 ADVISER NAME:- KAMIL DINO ADEM(PHD) TITLE-EXPERIMENTAL INVESTIGATION OF CONCENTRATED SOLAR BREAD BAKING OVEN INTEGRATED WITH THERMAL ENERGY STORAGE
CH-BY-KAMIL DINO ADEM(PHD)	MM		
DRAWING SCALE (FOR DESIGN & BLUEPRINT) 1:8			
PROJECTION		QTY-1	