

**ADDIS ABABA UNIVERSITY**  
**SCHOOL OF GRADUATE STUDIES**  
**FACULTY OF TECHNOLOGY**

**PERFORMANCE COMPARISON OF BROADBAND  
POWER LINE COMMUNICATIONS USING OFDM  
SYSTEMS**

A thesis submitted to the School of Graduate Studies of Addis Ababa University in  
partial fulfillment of the Degree of Masters of Science in Electrical Engineering

By  
Mulatu Mesfin

Advisor  
Prof. Wolde-Ghiorgis Wolde-Mariam

ADDIS ABABA  
Ethiopia  
December 2007

**ADDIS ABABA UNIVERSITY**  
**SCHOOL OF GRADUATE STUDIES**  
**FACULTY OF TECHNOLOGY**

**PERFORMANCE COMPARISON OF BROADBAND  
POWER LINE COMMUNICATIONS USING OFDM  
SYSTEMS**

BY

Mulatu Mesfin

Approval by Board of Examiners

_____	_____
Chairman (Department of graduate committee)	Signature
_____	_____
Advisor	Signature
_____	_____
Internal Examiner	Signature
_____	_____
External Examiner	Signature

## DECLARATION

I, the undersigned, hereby declare that this thesis is my original work performed under the supervision of prof. Wolde-Ghiorgis Wolde-Mariam has not been presented as a thesis for a degree program in any other university and all sources of materials used for the thesis are duly acknowledged.

Name: Mulatu Mesfin

Signature: -----

Place: Addis Ababa

Date of submission: -----

This thesis has been submitted for examination with our approval as university advisor.

Prof. Wolde-Ghiorgis Wolde-Mariam

-----

Signature

Addis Ababa  
Ethiopia  
December 2007

## ACKNOWLEDGEMENTS

First and foremost gratitude is due to Addis Ababa University of postgraduate studies, for my admittance, and to its faculty members for imparting quality learning and knowledge with their valuable support and guidance that has led my way through this point of undertaking my research work.

My deep appreciation and heartfelt gratitude goes to my thesis advisor Prof. Wolde-Ghiorgis Wolde-Mariam for his constant endeavor, guidance and the numerous moments of attention he devoted throughout this research work. His valuable suggestions made this work interesting and knowledgeable for me. Working with him in a motivating environment was really a joyful and learning experience.

I would also acknowledge to Dr. D.P. Roy, Ato Sintayehu and Ato Atlie, Ato Mulugeta Atlabachew, a post graduate student in AAU for their cooperation in providing facility.

I extend my deepest gratitude to the EEPCO staffs especially W/O Alganesh, the load dispatch center department head, Ato Behailu, the department engineer and Ato Ayalew, the communication department engineer for their great support in my thesis work.

Finally, Family support plays a vital role in the success of an individual. I would like to thank my parents since their encouragement always help me to take the right steps in life.

Addis Ababa,  
Ethiopia 2007

## **Abstract**

This thesis is directed to the performance comparison of broadband power line communications using orthogonal frequency division multiplexing modulation schemes.

Remarkable increase is promised in the near future, broadband power line communication systems are a preferable choice over wireless or other Home networking technologies due to factors including ease of installation, availability of AC outlets, higher throughput, low cost, reliability and security.

But there is a significant problem of interference (both in-bound and out-bound) which blocks the speed of data processing.

This thesis directs to the solution for this problem by using OFDM (BPSK, QPSK, and DPSK) systems and comparing the performances of them obtained from matlab results and selecting the better OFDM system.

Lastly the result of this thesis result is advantageous for all societies (urban and rural) enable them to get error free communications through the existed power line grid.

## Abbreviations

ADSL	Asynchronous digital subscriber line
BER	Bit Error Rate. Probability of a data word being transmitted in error.
BPSK	Binary Phase Shift Keying
BPLC	Broadband Power Line Communications
CAN	Customer access network
CDM	Code Division Multiplexing
CP	Cyclic prefix
DAB	Digital Audio Broadcasting system
DMT	Discrete multi tone
DPSK	Differential phase shift keying
DSL	Digital subscriber line
$E_bN_o$	Energy per bit to noise energy ratio (similar to SNR)
EEA	Ethiopian electric agency
EEPCO	Ethiopian electric power corporation
FDM	Frequency Division Multiplexing
FFT	Fast Fourier Transform
FCC	Federal communications commission
FSK	Frequency shift keying
GMSK	Gaussian noise minimum shift keying
HV	High voltage
ICI	Intercarrier interference
IFFT	Inverse Fast Fourier Transform
ISI	Intersymbol interference
ISDN	Integrated service digital network
ISPs	Internet service providers
IDFT	Inverse discrete Fourier transform
LAN	Large area network

LMU	Line matching unit
LV	low voltage
Mbps	Mega bit per second
MCM	Multicarrier modulation
MV	Medium voltage
OPGW	Optical ground wire
OFDM	Orthogonal Frequency Division Multiplexing
PLC	Power Line Communications
PSD	Power spectral density
QOS	Quality of service
QPSK	Quadrature Phase Shift Keying
RF	Radio frequency
SNR	Signal to Noise Ratio
TRS	Telecommunications relay service
VOIP	Voice over internet protocol
VSAT	Very small aperture terminal
WIFI	Wireless fidelity
WIMAX	Worldwide Interoperability for Microwave Access

## Glossaries

### **The Last Mile:**

It is the portion of the network that connects end users, such as homes and business, to high-speed services and the Internet. For residential broadband service customers who get cable modem service.

### **BPL modems:**

Which use silicon chips designed to send signals over electric power lines, much like cable and DSL modems use silicon chips designed to send signals over cable and telephone lines.

### **Inductive couplers**

They are used to connect BPL modems to the medium voltage power lines.

### **Router**

A device that acts as an interface between two networks and provides network management functions.

### **Repeater**

It is a physical-layer hardware device used on a network to extend the length, topology, or interconnectivity of the physical medium beyond that imposed by a single segment.

### **Injectors**

These are tied to the Internet backbone via fiber or other lines and interface to the MV power lines feeding the BPL service area.

### **Extractors**

Provide the interface between the MV power lines carrying BPL signals and the households within the service area. BPL extractors are usually located at each LV distribution transformer feeding a group of homes.

## **Carrier-Current System**

There are a number of types of BPL systems, using different approaches and architecture. All are “Carrier-Current” systems, a term used to describe systems that intentionally conduct signals over electrical wiring or power lines

## **Bandwidth Efficiency**

This is the ratio between the bit rate and the bandwidth of a communication system (bps/BW). Today a telephone system can achieve a bit rate of 56.6 kbps using a bandwidth of 4 kHz, so the bandwidth efficiency is  $56.6/4 = 14.15$  bps/Hz.

## **Signal to Noise Ratio (SNR)**

This is the ratio of received power to noise power. A higher SNR makes for easier communication because noise has a smaller effect on the signal. SNR is also affected by attenuation, which reduces signal power and thus SNR.

SNR can be increased by using filters to reduce noise outside of the bandwidth occupied by the signal.

## **Wi-Fi (Wireless fidelity)**

It allows LANs to be deployed without cabling for client devices, typically reducing the costs of network deployment and expansion. Spaces where cables cannot be run, such as outdoor areas and historical buildings.

**WiMAX**, the Worldwide Interoperability for Microwave Access, is telecommunications technology aimed at providing wireless data over long distances.

## List of figures

	Pages
Figure 1.1 Total coverage of the thesis .....	5
Figure 2.1 Functional blocks of digital communication systems.....	6
Figure 2.2 Structures of broadband solutions.....	8
Figure 2.3 Topology of power line communications.....	17
Figure 2.4 Classifications of broadband power line communications.....	20
Figure 2.5 Frequency bands of broadband power line communications..	27
Figure 3.1 Transmission Tower Size Relative to the Size of Local Power Poles.....	29
Figure 3.2 Node configuration of a power line.....	31
Figure 3.3 Broadband Power line communication channel model .....	32
Figure 3.4 Complete circuit for power line communications.....	32
Figure 3.5 Transfer function of the power line communication channel.....	36
Figure 3.6 Attenuation variations verses frequency of power line communication channel.....	37
Figure 3.7 Noise distribution of power line channel as frequency variations.....	38
Figure 4.1 Transmissions of broadband power line Communications signals.....	41
Figure 4.2 Block diagrams of OFDM systems for BPLC applications...	47
Figure 4.3 Spectrum analysis of OFDM signals.....	49
Figure 4.4 Concept of OFDM signals.....	50
Figure 4.5 Structure of OFDM carrier signals.....	50

Figure 4.6	Cyclic prefix as a copy of last part of OFDM symbol.....	53
Figure 4.7	Guard length arrangement of OFDM system.....	54
Figure 5.1	Broadband power line communications with different system architectures and its architecture.....	63
Figure 5.2	Basic coupling block diagrams.....	65
Figure 5.3	Different coupling methods of BPLC systems.....	67
Figure 5.4	Architectural design of LMU for BPLC systems.....	67
Figure 5.5	Broadband power line coupling circuit .....	71
Figure 5.6	Inductive coupling using ferrites.....	72
Figure 5.7	Inductive coupling schemes with ferrites and capacitors.....	72
Figure 5.8	Line traps of BPLC systems.....	73
Figure 6.1	Structural arrangements of OFDM systems.....	74
Figure 6.2	Randomly generated binary signals.....	76
Figure 6.3	Arrangement of bits in each of the subcarriers.....	77
Figure 6.4	Intersymbol interference in BPLC.....	77
Figure 6.5	Transfer function broadband power.....	78
Figure 6.6	Error performance comparisons of OFDM signals For ideal and power line channel.....	80
Figure 6.7	Bit error rate comparison of DPSK and QPSK .....	80
Figure 6.8	Theoretical (ideal channel) BER in dB comparisons of The three OFDM signals.....	81
Figure 6.9	Error comparison graphs based on different number of Sub-carriers of OFDM signals for BPLC application.....	85
Figure 6.10	BER comparisons of OFDM systems for BPLC applications.....	85

### List of tables

Table 2.1	Comparison of broadband solutions.....	11
Table 6.1	BER comparison of OFDM systems in BPLC applications	

using different sub-carriers ..... 82

**Table of Contents**

	<b>Pages</b>
Acknowledgments.....	i
Abstract.....	ii
Abbreviations.....	iii
Glossaries.....	v
List of figures.....	vii
List of tables .....	viii

**Chapter-one**

<b>1. General Introduction.....</b>	<b>1</b>
1.1 Background of the thesis .....	1
1.2 Objectives of the thesis .....	2
1.2.1 General objective .....	2
1.2.2 Specific objective.....	3
1.3 Methodology.....	3
1.4. Thesis out line .....	4

**Chapter-Two**

<b>2. Broadband power line communication systems.....</b>	<b>6</b>
---	----------

2.1 Digital communications systems .....	6
2.2 Broadband Communications systems .....	7
2.2.1 Broadband communications solutions.....	8
2.2.2 Comparisons of broadband solutions .....	11
2.3 Broadband power line communication systems.....	12
2.3.1 Components of Broadband Power Line Communication Systems.....	16
2.3.2 Classifications of broadband power line communications .....	18
2.3.3 Advantages of broadband power line communications. ....	20
2.3.4 Disadvantages of broadband power line communications.....	23
2.4 Applications of broadband power line communications .....	25
2.4.1 Broadband power line and satellite link.....	25
2.4.2 Broadband power line and WIMAX.....	26
2.4.3 Broadband power line for utilities.....	26
2.5 Avoidance of locally used frequencies in broadband power line communication .....	27

### Chapter-Three

<b>3. Broadband power line channel model.....</b>	<b>28</b>
3.1 Power line Transmission concept.....	28
3.2 Power line channel model description.....	30
3.3 Power-line transmission Channel Model.....	31
3.3.1 Channel transfer functions of a power line .....	32
3.3.2 Attenuation on power line communication channel .....	36
3.3.3 Noise on Power Line Channel.....	37

## Chapter-Four

<b>4. Orthogonal frequency division multiplexing in BPLC .....</b>	<b>41</b>
4.1 Introduction.....	41
4.2 Orthogonal Frequency-Division Multiplexing.....	44
4.3 Generation of OFDM signals for BPLC systems.....	46
4.4 Mathematical description of OFDM.....	48
4.5 Advantages of OFDM on BPLC systems.....	49
4.6 Disadvantages of OFDM System for broadband power line communication services.....	51
4.7 Guard Period insertion and the BPLC systems.....	52
4.8 OFDM and broadband power-line noise.....	54
4.9 Design Requirements and its parameters OFDM Systems in BPLC.....	55
4.10 Probability of error for BPLC signals.....	57
4.11 Design procedures of OFDM Signals for BPLC application.....	60

## Chapter-Five

<b>5. Interfacing systems and broadband power line communications.....</b>	<b>62</b>
5.1 Coupling devices for power line communications.....	63
5.2 Coupling circuit configurations.....	66
5.3 Line-matching unit and its architecture.....	67
5.4 Coupling Circuit Components.....	69
5.5 Line traps broadband power line communications system.....	73

## Chapter-Six

<b>6. Results of the thesis and conclusions.....</b>	<b>74</b>
6.1 Simulation results of the thesis .....	74
6.2 Conclusions of the thesis.....	86
6.3 Recommendations and further works .....	87
Reference.....	89

## Chapter-one

### General Introduction

#### **1.1 Background of the thesis**

Across the globe it's very much still a luxury to have broadband. Since most people do have electric power lines running to their house it sound like a fantastic idea to provide broadband over these lines. Telecommunication pipelines are expensive to build especially in third world countries but this technology would make it a viable option. You will notice that your house has electrical wires ending in almost all rooms of a residential home. It would be very convenient to already have a broadband hook up available to connect into. Having the infrastructure in place already is quite an amazing accomplishment the power lines are able to provide us. A high-speed broadband Internet hookup through a power line is just as fast as a cable modem and even faster than DSL service [1].

At first, Power Line Communication (PLC) systems, which have been around since 1950's but were never thought seriously of as communications method due to low speed, high cost for development, and were designed with out any data communication considerations and exhibit highly variable levels of impedance, signal attenuation and noise which are obstacles that degrade the performance of information processed [1]. But recent progress in power line communication brings the system of broadband power line communications that increases the speed of data processing on the existing power line, this is thanks to the technological advances such as new modulation schemes like OFDM, which can minimizes the electromagnetic field radiation from the line and provide relatively high data rates more than 45Mbps, which can transform

every single wall socket into an interface to the World Wide Web which enables us getting broadband services like voice, data, graphics, and video transmissions.

Broadband power line communications (BPLC) can be applied to high, medium, and low-voltage supply networks as well as within buildings. This technology is now used mainly for access networks and in-home communication networks, since the high cost of the access networks (about 50% of the investments in network infrastructure are needed for the access area) [2].

As it is well known that power lines are not designed only for communication purposes and do not present a favorable transmission medium because of The PLC transmission channel is characterized by a large, frequency-dependent attenuation, changing impedance, fading, a strong influence of noise, as well as very strong limits of regulatory bodies due to the electromagnetic emission from PLC networks to the environment that interfere other licensed services; But these negative impacts of broadband power line transmission medium is avoided by applying an efficient modulations scheme called OFDM [3].

Using OFDM systems, by comparing and selecting the best of these systems, BPLC becomes a competent even more than other access technologies and to offer a wide palette of telecommunication services with a satisfactory QoS, both good network utilization and provision of QoS guarantees can be achieved.

## **1.2 Objectives of the thesis**

Getting error free communication is the choice of every nation, this paper directs to access broadband services through the power line grid, which is in a problem of interferences and other difficulties in both rural and urban areas. Developing a strategic plan for broadband deployment using BPLC services is promising, relatively because of low population density, topographical barriers, and greater geographical distances, broadband services was more difficult to obtain in rural areas but now.

### **1.2.1 General objective**

In general performance comparison of broadband power line communications is very essential so as to perform the following:

- To create an opportunity to access broadband services with a minimum of error through the existing power line grid using Orthogonal Frequency Division Multiplexing (OFDM) systems.

### **1.2.2 Specific objective**

Specifically this thesis is very important in the area of broadband communication systems

- To compare and select the best OFDM system for Broadband Power Line Communications (BPLC) application

### **1.3 Methodology**

So as to succeed this thesis a lot of methods and procedures are going on. The randomly generated data, which is an electric signal from anywhere, is processed as voice (information) and pass through different OFDM techniques, finally this result is convolved with the modeled power line channel. At the receiver the reverse process is performed to recover the original data. After that the performance comparison of the transmitted data and the received data is done based on for three of OFDM systems and their error comparison is conducted. The experimental simulation is using matlab, which enables to study the performance of power line for broadband communication services. Useful materials for this thesis are collected from Ethiopian telecommunication, Ethiopian electric agency, EEPCO, journals, related books and, down-able sites... as it is stated in the reference.

## **1.4 Thesis out line**

The performance comparison of broadband power line communication systems has a great role to access broadband services by selecting the better modulation scheme. This thesis contains the total of six chapters,

Chapter one is general introduction of a thesis, which highlights the basic idea and gives an insight or a direction to the body of the thesis, in addition a discussing on the feedback of the thesis.

Chapter two focuses on broadband power line communications systems, the advantages and the limitations of broadband power line communications, the applications of it and also the comparisons of different broadband solutions based on different parameters.

Chapter three tells about broadband power line communications channel models, which covers the channel modeling, the factor that determines the performance of the channel, by considering and analyzing attenuation and noise.

Chapter four: - deals about the modulation schemes, the different types of OFDM methods used in broadband power line communications systems, the advantages and disadvantages of this modulation scheme in the area of broadband power line communication systems and the comparison based on error probability.

Chapter five covers the interfacing methods and components of broadband power line communications, the line matching unit, the line trap, and the coupling devices.

Chapter six develops the simulation result of BER verses SNR based on the analysis designed, the frequency dependent parameters of the channel and conclusion on what is done in this project and suggest the recommendations for the future work.

The above outlines are generalized as in figure 1.1 below.

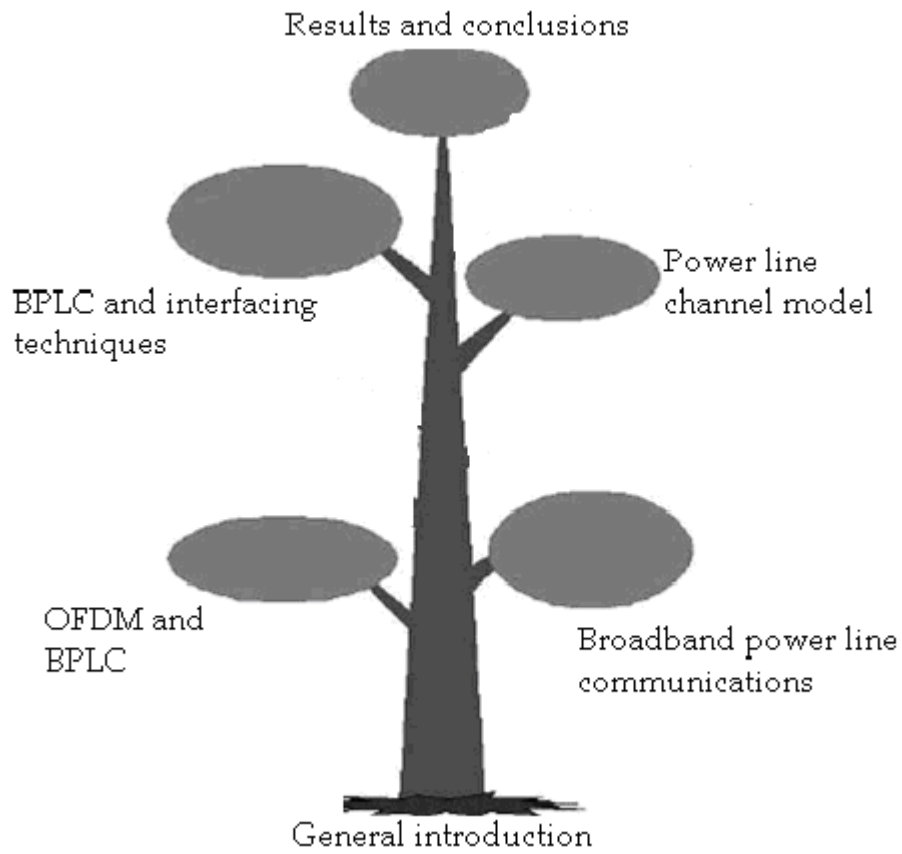

Figure 1.1 Total coverage of the thesis

## **Chapter-Three**

### **Broadband power line channel model**

The power line communication channel is a notoriously bad channel that has been developed without regard for any communications considerations. So special care is taken during designing and modeling it [17].

In order to design a communication system for a specific channel it is preferable to have some basic knowledge of the characteristics of the channel.

If a communication system can be matched to a channel, it increases the performance. The geographic coverage of the low-voltage system is usually very wide where human habitation exists, and the access to the network can be simple. On the other hand, power lines represent a particularly difficult communications environment. Noise levels may be excessive. The cable attenuation at frequency of interest to communication is usually very large. So repeater may be needed to compensate for cable losses, and to bridge over distribution transformers. Standing waves on line cables may lead to nulls in the frequency response. Electro-magnetic compatibility problems arise when interfacing electronic circuits with electrical power lines.

#### **3.1 power line Transmission concept**

There are many varieties of transmission lines, the three common types are

- Two wire transmission line
- Coaxial transmission line
- The micro-strip transmission line

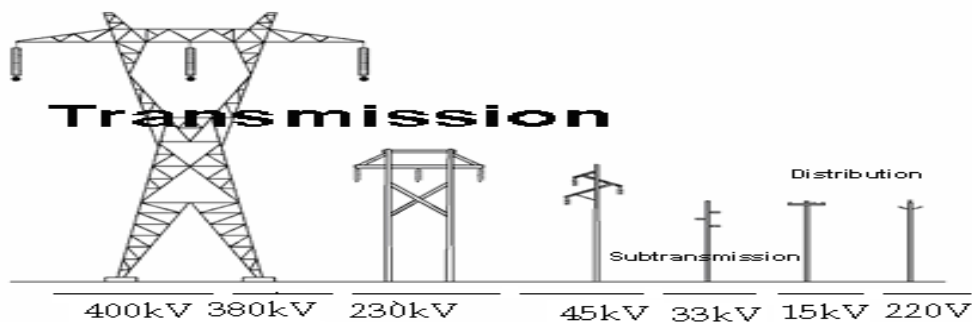

Figure 3.1 Transmission Tower Size Relative to the Size of Local Power Poles

As figure 3.1 above, Power lines connect the power generation station to a variety of customers dispersed over a wide region. Power transmission is done using varying voltage levels and power line cables. Power line cable characteristics and the number of crossovers play an important role in determining the kind of communication technology that needs to be used. Based on the voltage levels at which they transfer power lines can be categorized as follows.

- ✚ High-voltage lines (45kV-230kV / 400kV): These connect electricity generation stations to distribution stations. The voltage levels on these lines are typically in the order of hundreds of kilovolts and they run over distances of the order of tens of kilometers.
- ✚ Medium-voltage lines (15/33kV): These connect the distribution stations to pole mounted transformers. The voltage levels are of the order of a few kilo volts and they run over distances of the order of a few kilometers.
- ✚ Low-voltage lines (220/380V/400V) these connect pole-mounted transformers to individual households. The voltage levels on these lines are of the order of a few hundred volts and these run over distances of the order of a few hundred meters.

High-tension lines represent excellent carriers for RF energy as we only find open wire equipment with very few crossovers. A transmission power of about 10 watts is often sufficient to overcome distances of more than 500 kilometers.

Medium and low tension lines are characterized by large number of cross connections and different conductor types (e.g. open wire and cable). Long distance RF signal propagation is extremely bad in this environment because of high attenuation and impedance matching problems.

So as to model a transmission line for high data rate transmission the following models can be used;

- Short transmission line (up to 80 km).
- Medium transmission line (80-240 km).
- Long transmission line (more than 240 km).

### 3.2 Power line channel model description

In reality we would have to deal with a network with complex structure, with several kinds of cables, nodes with multiple derivations and varying load impedances, which implies multiple reflections and obviously would degrade significantly the transmission performance of the channel. It is focused on a configuration which connects three power cables in a derivation point. One of the three end nodes called Input and the other two Output 1, and Output 2 respectively.

When figure 3.2 is referred, the injected signal is propagating from the input towards the two outputs passing through the derivation point, where part of it, being reflected, comes backwards, etc. Having this configuration the amplitude of the signal during its propagation in the line becomes minimized as well as the shape of the step responses at the end nodes.

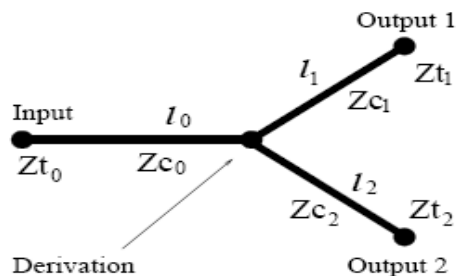

Figure 3.2 Node configuration of a power line

### **3.3 Power-line transmission Channel Model**

In addition to the frequency dependent attenuation that characterizes the power line channel, deep narrow band notches occur in the transfer function, which may be spread over the whole frequency range. These notches are caused by multiple reflections at impedance discontinuities. The length of the impulse response and the number of the occurred peaks can vary considerably depending on the environment. Transfer characteristics of power line channels can be regarded as quasi-stationary, as their changes occur only as a result of changes in the topology and changes in the load situation. Mainly the connecting or switching of electrical appliances causes load changes.

The growing interest in using electrical power networks as an alternative broadband communication medium has spurred many to study the channel characteristics and to formulate channel models of these power networks.

Existing channel-modeling techniques for broadband power-line communications (BPLC) typically assume that the power networks are connected in tree or radial topology. This assumption is not entirely valid as many electrical circuits in residential homes, commercial and industrial facilities may be wired in ring topology. Using the concept of scattering or ABCD parameters or other method derives analytical expressions for the channel transfer function and input impedance of ring-based BPLC networks, which conducts up to a frequency of 45MHz and even above [18]. The general power line communication model indicated in figure 3.3 below is one of the three model alternatives.

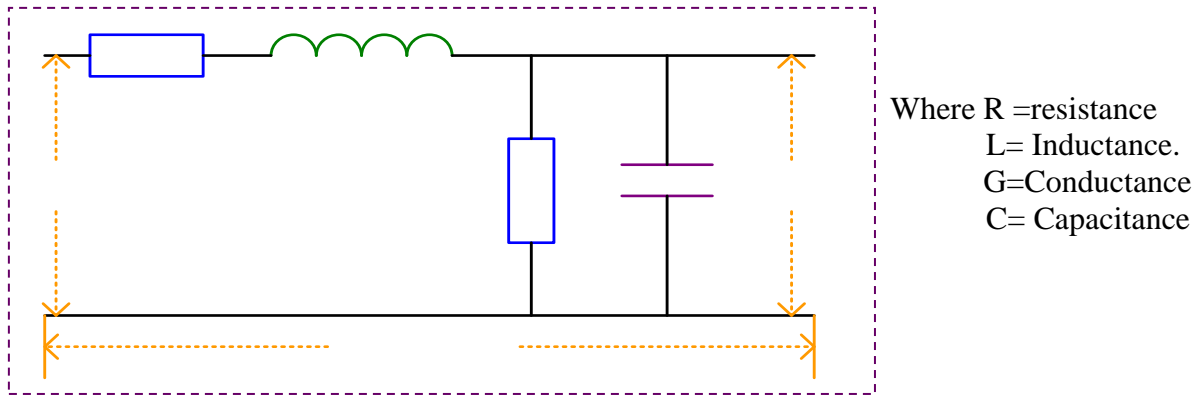

Figure 3.3 Broadband Power line communication channel model

### 3.3.1 ABCD parameters and channel transfer functions of a power line

The ABCD representation for a two port circuit is very convenient for the calculation of channel transfer functions based on the relation between  $V_1, V_2, I_1, I_2$  can in general be represented as

$$\begin{bmatrix} V_1 \\ I_1 \end{bmatrix} = \begin{bmatrix} A & B \\ C & D \end{bmatrix} \begin{bmatrix} V_2 \\ I_2 \end{bmatrix}$$

Where A, B, C and D are appropriately chosen constants.

It is easy to show that if we have a cascade of two-port circuits (mostly parallel tapping is taking place), the ABCD representation of this circuit is the product of the ABCD matrices for the individual two-port circuits as figure 3.4 below.

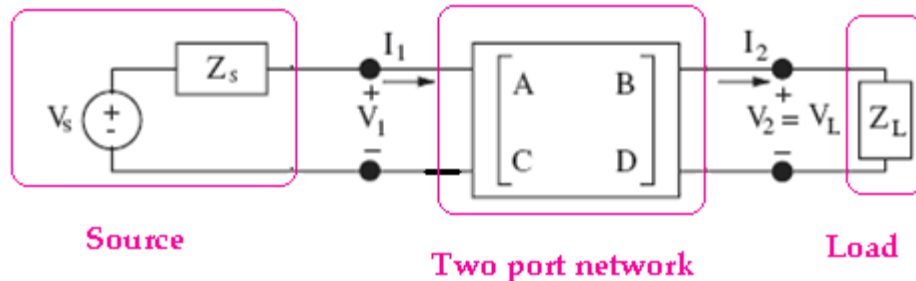

Figure 3.4 a complete circuit for power line communications.

Two parallel cables can be modeled as a transmission line. Its characteristic impedance  $Z_c$  can characterize a transmission line; and its propagation constant  $\gamma$ . By measuring the per-unit-length parameters of a cable it is easy to calculate the characteristic impedance  $Z_c$ ; and propagation constant  $\gamma$  of the cable as;

$$Z_c = \sqrt{\left(\frac{R \Delta l + j\omega L \Delta l}{G \Delta l + j\omega C \Delta l}\right)}$$

$$\gamma = \sqrt{(R \Delta l + j\omega L \Delta l)(G \Delta l + j\omega C \Delta l)}$$
3.1

Where R, L, G and C are per-unit-length resistance, inductance (H/m), conductance (S/m) and capacitance (F/m), respectively, and  $\omega$  is frequency (rad/s). The ABCD matrix for a transmission line with characteristic impedance of  $Z_c$  and propagation constant of  $\gamma$  and a length of  $l$  can be calculated as follows [19], Let  $dx$  is an elementary length, then

$$dV = IZ dx, \quad \frac{\partial V}{\partial x} = IZ$$
3.2

The solution for the above equation (3.2) may be written as

$$V = C_1 e^{\gamma x} + C_2 e^{-\gamma x}$$
3.3

By differentiating equation above the following is achieved

$$\frac{\partial V}{\partial x} = C_1 \gamma e^{\gamma x} - C_2 \gamma e^{-\gamma x} = IZ$$
3.4

$$I = \frac{\gamma}{Z} C_1 e^{\gamma x} - \frac{\gamma}{Z} C_2 e^{-\gamma x}, \text{ since } I = \frac{1}{Z_0} (C_1 e^{\gamma x} - C_2 e^{-\gamma x})$$
3.5

From equation 3.3 & 3.5 by evaluating  $C_1$  and  $C_2$  at  $x=0$  ( $V=V_R, I=I_R$ ), it is found that;

$$C_1 = \frac{(V_R + Z_0 I_R)}{2}, \text{ and}$$

$$C_2 = \frac{V_R - Z_0 I_R}{2}$$
3.6

Then substitute  $C_1$  and  $C_2$  from the above eq. 3.3 & 3.5

$$\begin{aligned} V &= \frac{V_R}{2} (e^{\gamma x} + e^{-\gamma x}) + \frac{I_R}{2} Z_0 (e^{\gamma x} - e^{-\gamma x}) \\ I &= \frac{V_R}{2 Z_0} (e^{\gamma x} - e^{-\gamma x}) + \frac{I_R}{2} (e^{\gamma x} + e^{-\gamma x}) \end{aligned} \quad 3.7$$

Which is equivalent to

$$\begin{aligned} V &= V_R \cosh \gamma x + I_R Z_0 \sinh \gamma x \\ I &= \frac{V_R}{Z_0} \sinh \gamma x + I_R \cosh \gamma x \end{aligned} \quad 3.8$$

When  $x$  is any value of length  $\Delta x$ , it can be rearranged as follows to create the ABCD parameters of a broadband power line channel.

$$\boxed{\begin{bmatrix} A & B \\ C & D \end{bmatrix} = \begin{bmatrix} \cosh(\gamma \Delta l) & Z_c \sinh(\gamma \Delta l) \\ \frac{1}{Z_c} \sinh(\gamma \Delta l) & \cosh(\gamma \Delta l) \end{bmatrix}} \quad 3.9$$

The transfer function of the power line channel can be calculated based on the model as

$$\text{follows, } \frac{V_0}{V_i} = \frac{1}{(G \Delta l + 2CS \Delta l)(R \Delta l + LS \Delta l) + 1} = T.F = H \quad 3.10$$

Therefore the power line channel model transfer function is

$$T.F = \frac{1}{(\Delta l)^2 (G + 2CS)(R + LS) + 1} \quad 3.11$$

Where  $R, G, L, C$  are power line transmission parameters and

$\Delta l$  is length of the of the power line. Alternatively, the BPLC channel can be described by means of a discrete-time impulse response.

$$h(t) = \sum_{i=1}^N c_i * \delta(t - \tau_i) \Leftrightarrow H(f) = \sum_{i=1}^N c_i * e^{-j2\pi f \tau_i} \quad 3.12$$

Factoring in the formula of the channel attenuation, the transfer function in the frequency domain can be written as

$$H(f) = \sum_{i=1}^N g_i * e^{-\alpha(f)d_i} * e^{-j\beta(f)d_i} \quad \text{or}$$

$$H(f) = \sum_{i=1}^N g_i * e^{-A(f, d_i)} * e^{-j2\pi f\tau_i} \quad 3.13$$

Where A (f, d<sub>i</sub>) is the signal attenuation proportioned with the length and frequency , the weighting factor g<sub>i</sub> is complex and frequency-dependent because the reflection points may have complex and frequency-dependent values representing the product of the reflection and the transmission factors along the path., N is the number of significant arrived paths at the receiver, The variable τ<sub>i</sub> representing the delay introduced by the path (i), is the function of the path length d<sub>i</sub> (is the length of i<sup>th</sup> path) By replacing the medium attenuation A (f, d<sub>i</sub>) by the expression given in Eq.(3.13), we obtain the final equation defining the BPLC channel model, encompassing the parameters of its three main characteristics: attenuation ,impedance fluctuations , and multi-path effects. In short the transfer function is composed of weighting terms, an attenuation term, and delay term.

$$H(f) = \sum_{i=1}^N g_i * e^{-(\alpha_0 + \alpha_1 * f^k)d_i} * e^{-j2\pi f d_i}$$

3.14

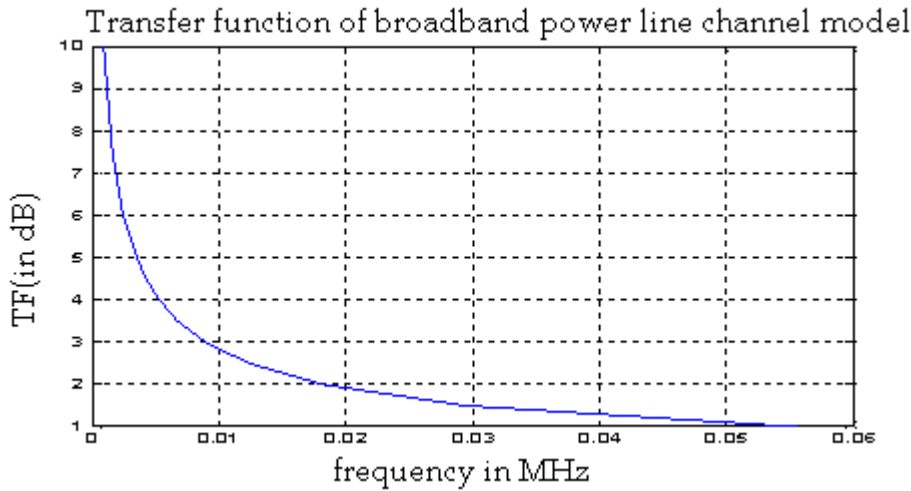

(a)

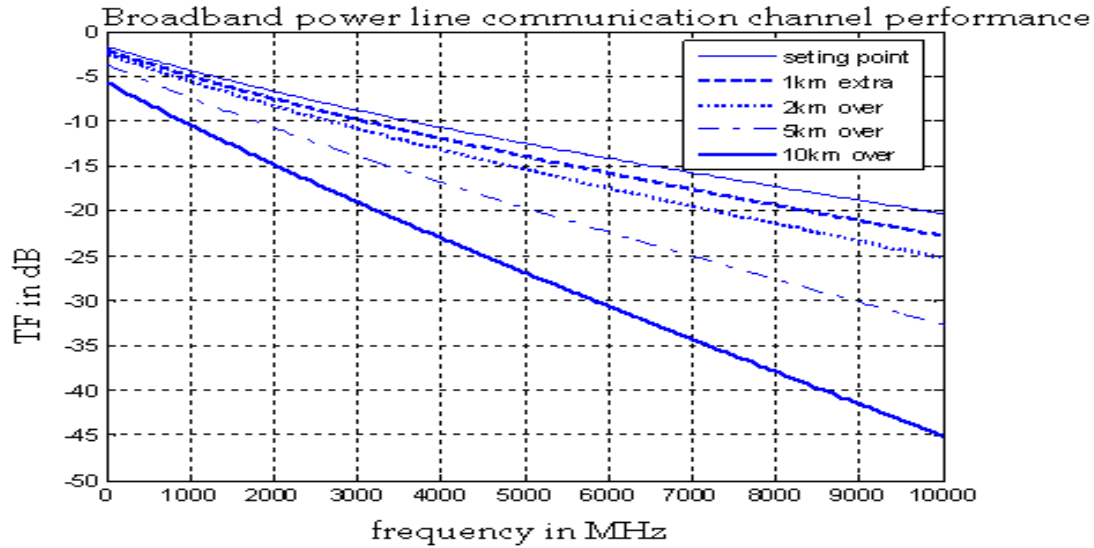

(b)

Figure 3.5 Transfer function of the power line communication channel

(a) With fixed length

(b) with different length

The above figure 3.5 tells the transfer function of a line is inversely proportional to the length of the path and the relation b/n output of the line and supply frequency which are inversely related.

### 3.3.2 Attenuation on power line communication channel

Attenuation is the drop in the signal power when transmitting from one point to another. It can be caused by the transmission path length, obstructions in the signal path, and multi-path effects Signal [20].

The propagation constant  $\gamma = \alpha + j\beta = \sqrt{(R + j\omega L)(G + j\omega C)}$  where  $\gamma$  is the propagation constant in per meter,  $\alpha$  is attenuation constant in nippers per meter and  $\beta$  the phase constant in radians per meter.

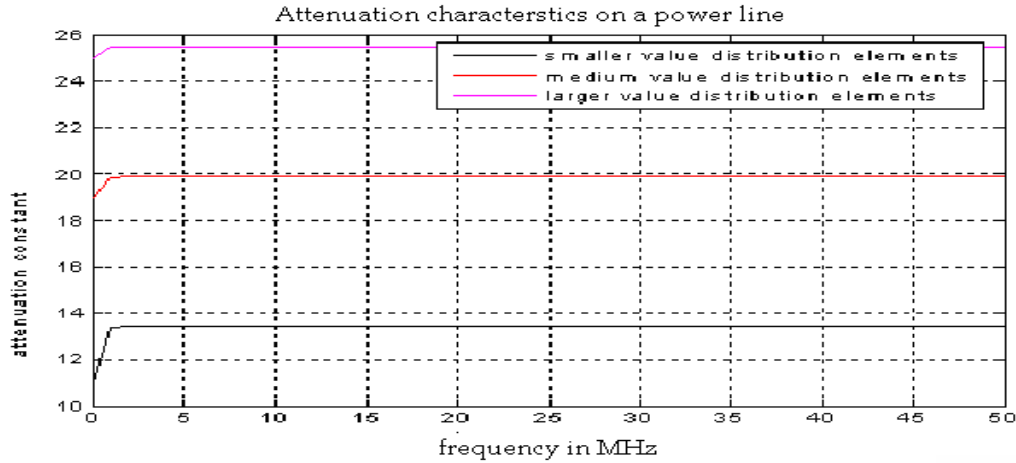

Figure 3.6 attenuation variations verses frequency of power line communication channel.

*Note:-*From the fig 3.6 above one can conclude that the attenuation of the power line channel is directly proportional to the frequency.

### 3.3.3 Noise on Power Line Channel

Noise that affects communications on the power line circuit is due mainly to light dimmers, universal motors and some power line based intercom modules [21]. Recent development of Audio and Video transmitters that use the power line as the signal transport media have made matters worse. It has been found that dimmer generated noise is much greater and harmful than that generated by universal motors. Moreover, dimmers generate both odd and even harmonics of 50 Hz which can severely impair the PLC network if they are not properly filtered, although some manufacturers argue that this noise attenuates very fast as frequency increases, becoming harmless at the frequencies of interest. Jitter can be considered as another source of noise as mentioned before. Television receivers and computer monitors are another cause for concern since they produce a significant amount of line noise at multiples of the horizontal sweep frequency. Noise that is periodic in nature such as impulse noise caused by thermostats or lightning can be overcome by use of an appropriate error correction code. The important point here is that all these common sources of noise have to be analyzed and

dealt with when a PLC network is being implemented, otherwise, the network will not operate reliably.

Besides signal distortions due to the low-pass characteristic of the power-line and multi-path propagation of the signals, data transmissions over power-lines are mainly impaired by noise which cannot be modeled as additive white Gaussian noise. Instead, noise on the power-line can be classified into five categories according to its characteristics. These are colour noise, narrow band noise, periodic impulse noise which is asynchronous to the mains, periodic impulse noise which is synchronous to the mains and finally asynchronous impulse noise. The noise types 1, 2 and 3 usually show stationary behavior over periods of seconds, minutes or even hours and therefore can be considered as background noise. The noise types 4 and 5, on the other hand, show time-variance in terms of microseconds or milliseconds. These impulses lead to a severe temporary increase in power spectral density (psd) and hence data transmission can be affected by bit errors. The power spectral density of this noise type was found to be a decreasing function of the frequency in the frequency band of interest, on average equal

to

$$N(f) = 10^{k-3.95 \times 10^{-5}f}$$

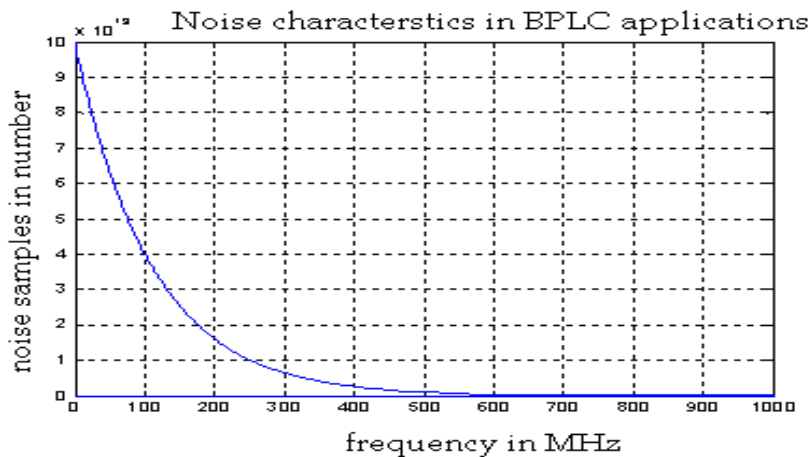

Figure 3.7 Noise distribution of power line channel as frequency variation, where k is a

variable changing with time and locations, here in this figure 3.7, it is possible to infer that at higher frequency the noise is not that much worst but at lower frequencies.

i. **Random pulse noise**

It is mainly occurred when the protection switch turning off or on. Each pulse noise will affect a very broad band. Its arrival time is random, and it can last from several  $\mu$ s to several ms. The pulse wave shape is like damping sine wave or serried damping sine wave.

ii. **Continuous noise irrelevant to the power frequency.**

It is mainly produced by the horizontal scanning signals of the TV set and monitors, the peak on the power spectrum graph appears at the horizontal scanning signal and its harmonic frequency points. The repeating frequency is usually 50 to 200Hz.

iii. **Periodic noises synchronized to the power frequency.**

The electronic devices mainly produce it, the repeating rate is 50Hz or 100Hz, it last only for a very short time, the power spectrum decreases when the frequency increases.

These electronic devices are air conditioner, computer, etc. The disturbance sometimes can be very large; the peak value can reach over 10V.

iv. **Background noise**

It is a compound interference produced by all the noises on the power line, is a random interference varied slowly with time, its power spectrum density decreases when frequency increases. The background noise basically keeps a level state in the 100 kHz to 10MHz band. Its feature appears to be white noise. The noises on the power line are very complicated; the amplitude damps with the growing frequency, the distribution of the noise changes when the time, address and load vary. We setup the noise generator in a virtual instrument way, the noise synthesis is done by software, the customer can

expand the functions with programming to get the highest cost performance, without changing the original circuits. The statistical analysis and modeling of noise on the power-line requires numerous measurements at different locations. Additionally, for characterization of time variance of noise it is necessary to consider longer periods of time.

## Chapter-Five

### Interfacing systems and broadband power line communications.

A communications terminal for transmitting and receiving communication signals over a power line communications network and including an interface circuit for coupling the terminal to the power line of the network is included. One embodiment of the network includes a transformer for coupling communication signals between the power line and the communication terminal [30].

BPL equipment consists of injectors (also known as concentrators), repeaters, and extractors. BPL injectors are tied to the Internet backbone via fiber or solid lines and interface to the short, Medium and large Voltage (MV) power lines feeding the BPL service area [29]. MV power lines may be overhead on utility poles or underground in buried conduit. Overhead wiring is attached to utility poles that are typically 10 meters above the ground. Three phase wiring generally comprises an MV distribution circuit running from a substation, and these wires may be physically oriented on the utility pole in a number of configurations (horizontal, vertical, or triangular). One or more phase lines may branch out from the three phase lines to serve a number of customers. A grounded neutral conductor is generally located below the phase conductors and runs between distribution transformers that provide Low Voltage (LV) electric power for customer use. In theory, BPL signals may be injected onto MV power lines between two phase conductors, between a phase conductor and the neutral conductor, or onto a single phase or neutral conductor. Extractors provide the interface between the MV power lines carrying BPL signals and the households within the service area. BPL extractors are usually located at each LV distribution transformer feeding a group of homes. Some extractors boost BPL signal strength sufficiently to allow transmission through LV transformers and others relay the BPL signal around the transformers via couplers on the proximate MV and LV power lines. Other kinds of extractors interface with non-BPL devices (e.g., WiFi) that extend the BPL network to the customers' premises. For long runs of MV power lines, signal attenuation or distortion through the

power line may lead BPL service providers to employ repeaters to maintain the required BPL signal strength and fidelity. Figure 5.1 illustrates the basic BPL system, which can be deployed in cell-like fashion over a large area served by existing MV power lines

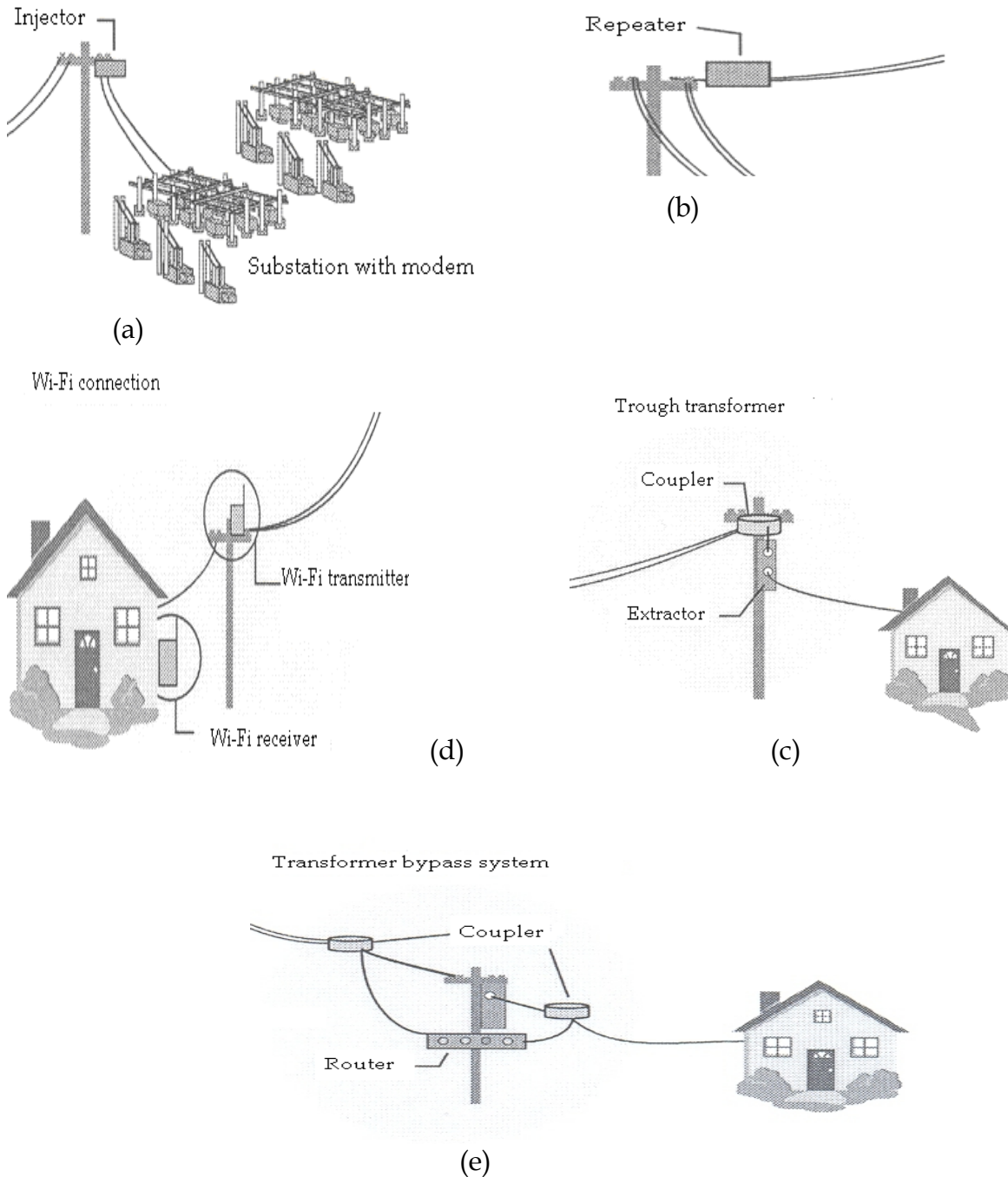

Figure 5.1 Broadband power line communications with different system architectures

## 5.1 Coupling devices for power line communications

The superimposing of a BPLC signal on a power waveform implies that the coupler circuitry and power circuitry would have to be carefully designed and interfaced for optimal Compatibility between the two systems. Power system and the communication system operate at the two extremes, power system at very low frequency and very high power, current and voltages levels and communication systems at much higher frequencies and very low power, current and voltage levels [30].

To be able to design BPLC systems as well as to supply a proper interface between power and communication system the coupling circuitry as shown in figure 5.2 must be clearly understood. Coupling of the communication signal on the BPLC channel can be achieved using several closed current paths.

The broadband power line carrier technique, using the power line as the transmission medium, requires particular interfacing functions between the telecommunications equipment and the high voltage components such as the line, the line trap, and the coupling capacitor.

In one aspect, a device for interfacing a communication signal with an electrical power network in a building having at least one service panel includes a coupling device configured to couple a modulated communication signal to a power-line network and one or more reset-able breakers each configured to allow for manual disconnect and configured to provide over-current protection, the one or more reset-able breakers each being electrically coupled to the coupling device and configured to be electrically coupled to the electrical power network. In another aspect, a device for interfacing a communication signal with an electrical power network in a building having at least one service panel includes a coupling device configured to couple a modulated communication signal to a power-line network, and an electrical breaking means coupled to the coupling device for providing manual disconnect and over-current protection. Such a device also eliminates the need of separate fusing and cut-off mechanisms and providing enhanced integration and economy.

An efficient coupling path must be provided between the BPLC transceiver and the high voltage line is achieved by the proper combination of coupling devices, line traps, and coupling capacitors. In conjunction with the coupling capacitor, the line tuner or coupling device provides a low loss signal path for selected BPLC frequencies while attenuating other PLC frequencies and noise.

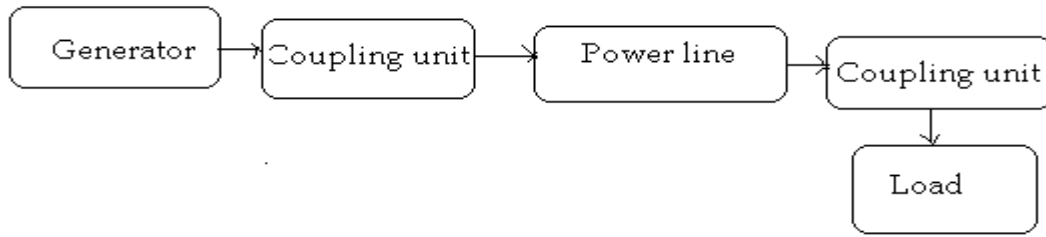

Figure 5.2 Basic coupling block diagrams

The most critical component of any Broadband Power Line Communication (BPLC) system is its interface circuit (or coupling circuit) with the power distribution network. This is by no means a simple unit considering the challenging characteristics of the BPLC channel. Due to high voltages, varying impedances, high amplitudes and time dependent disturbances, coupling circuits need to be carefully designed to provide both the specific signal transmission with the appropriate bandwidth, and the safety level required by the applicable domestic or international standard. In this project we discuss various aspects on broadband coupling circuit types like inductive coupling, capacitive coupling and some hybrid. The superimposing of a BPLC signal on a power waveform implies that the coupler circuitry and power circuitry would have to be carefully designed and interfaced for optimal compatibility between the two systems. The couplers are different, an inductive coupler, capacitive coupler or other. The inductive coupler has two windings. The first winding is in series with a line conductor of the power distribution system. A capacitor is connected between the first line conductor and a second line conductor of the distribution system such that the capacitor presents high impedance to a power signal and low impedance to a data signal.

A communication device is connected to the second winding so that a data signal can be coupled between the communication device and the distribution system. A communication signal is coupled simultaneously to all three phases of a neutral-wye three-phase line through a transformer arrangement consisting of a low voltage set of three serially connected windings across which the signal is applied to produce the same current in all three windings and a high voltage set of three windings which are connected in a neutral-wye configuration to the power line with a winding of each set being magnetically coupled to a different winding of the other set such that the currents induced in all three windings of the high voltage set flow in the same direction with respect to the neutral connection.

## 5.2 Coupling circuit configurations

The principle of modularity adopted for the design of this equipment allows the different coupling configurations encountered in the following power line techniques [31] as indicated in figures 5.3 and figure 5.4.

- ✚ Phase-earth coupling
- ✚ Phase -phase coupling
- ✚ Inter circuit coupling (line -line coupling)

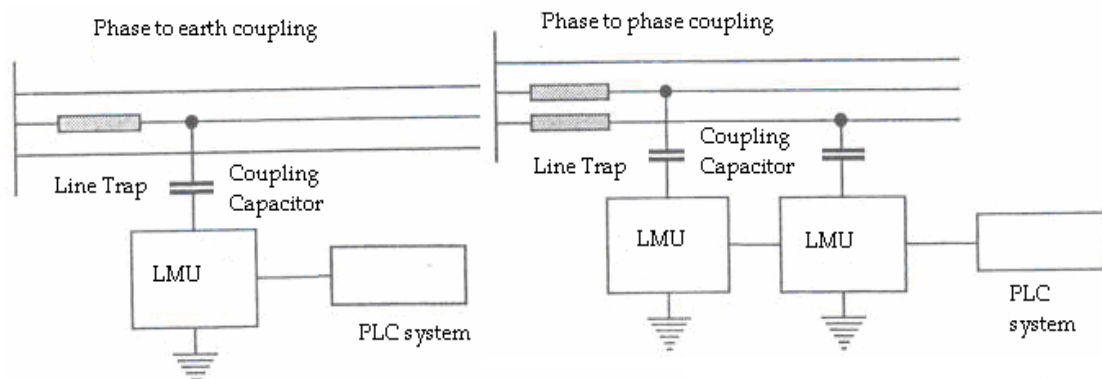

(a)

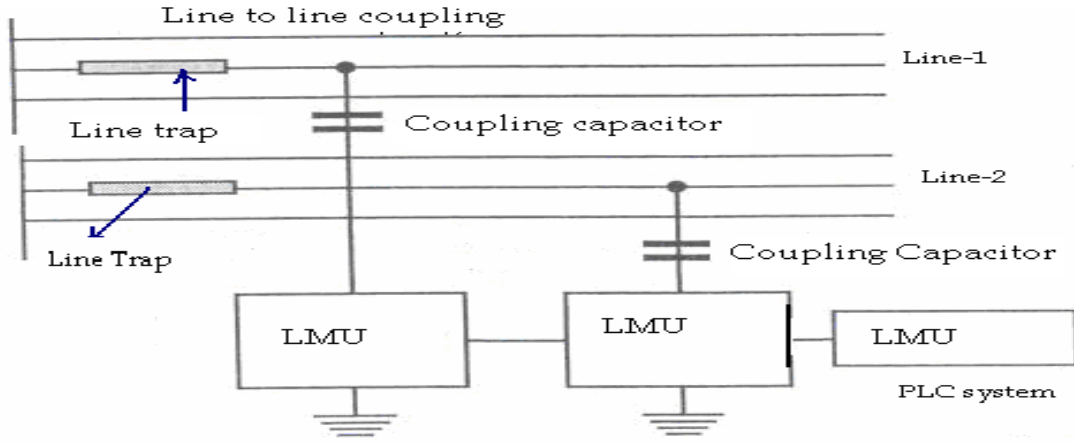

(b)

Figure 5.3 (a), (b) different coupling methods of BPLC systems.

### 5.3 Line-matching unit and its architecture

Line matching unit is the architecture of the LMU contains the three basic units; these are the protection unit, the tuning unit and the matching unit [32].

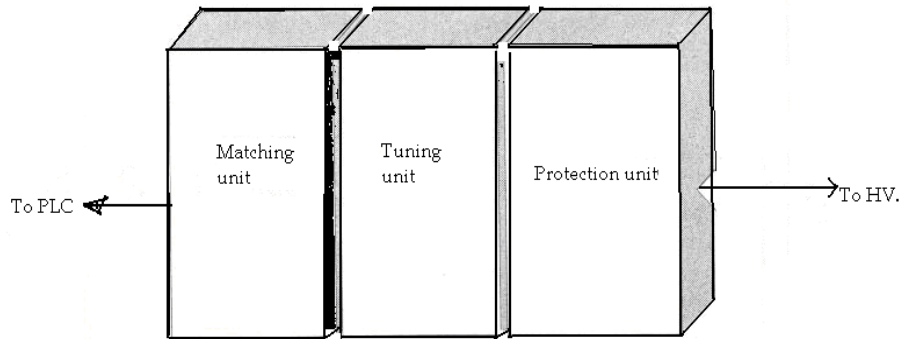

Figure 5.4 Architectural design of LMU for BPLC systems.

#### a) The protection unit

This unit offers a very efficient protection against the HV power effect and the transient voltage picks. It ensures the safety of the staff and the protection of the power line carrier equipment. It is a composed of three protecting devices,

- **Earthing switch**

By a direct earthing at low-level point of the coupling capacitor. This switch offers a reliable protection to personnel and equipment during maintenance or commissioning tasks.

- **The surge arrester**

A primary surge arrester provides a protection against spark over voltage. A secondary lightning arrester contributes to keep the equipment terminal in safe conditions

- **The draining coil.**

The draining coil gets to earth the power frequency current coming from the H.V line through the coupling capacitor, which is protected against any unwanted contact.

**b) A Tuning unit**

This unit consists of a resonant circuit in order to form a band pass filter with the line components (the coupling capacitor represents the main of these). It optimizes the coupling (minimum loss).

**c) A matching unit**

This unit matches the high voltage line impedance to the power line carrier equipment one.

**d) Additional devices**

An additional attenuator is available for short line with low R.F attenuation. RF digital information signals are interfaced with a high, medium and low voltage power line data channel. An interface circuit connects between the medium voltage and low voltage sides of a step-down power transformer. The opto-coupler provides an added margin of safety for coupling communications data while isolating the medium voltage power from the low voltage side of the transformer.

To be able to design BPLC systems as well as to supply a proper interface between power and communication system the coupling circuitry must be clearly understood. Coupling of the communication signal on the BPLC channel can be achieved using several closed current paths [33].

- ✚ Differential mode coupling: In this case the 'line' wire is used as one terminal and the 'neutral' wire is used as the second terminal.
- ✚ Common mode coupling: In this case the line and neutral wires are used together, forming one terminal and the ground' wire serves as the second terminal. This coupling mode is known to yield up to 30 dB better coupling than the differential coupling. In some countries, common mode coupling is not allowed on the low voltage networks, due to potential danger for the customers.

## 5.4 Coupling Circuit Components

To be able to design an optimum coupling circuit, appropriate components must be chosen and their operation must be understood.

The line coupler is a simple device consisting of a resistor, capacitor and transformer. Proper selection of the resistor and capacitor ensures that the 60 Hz mains signal is greatly attenuated so it doesn't affect the communication electronics, yet higher frequencies pass through with little attenuation.

- ✚ **Coupling capacitors:** These are extensively used in power line communications, most commonly to couple the PLC signal to the power line, but also as a part of more sophisticated, higher-order filters. The requirements and essential characteristics of coupling capacitors have been standardized in ANSI Coupling capacitors carry the communication current and thus have to be high-frequency capacitors (self resonant frequency has to be higher than the modulation frequency). Conversely, they have to filter the power voltage (dropped across the component), as well as voltage surges and therefore need to be high-voltage capacitors. The filtering characteristics of the coupling capacitors are quite dependent on the load onto which the waveform terminates.
- ✚ **Coupling transformers:** The main function of the coupling transformers is to provide galvanic isolation and impedance adaptation, but the coupling transformer has also to pass the high-frequency communication signal and it has to be designed as such. The power waveform has a much lower frequency and

much higher voltage level, and the power waveform has a saturating influence compared to the communication waveform. Therefore, the power waveform is typically first low pass filtered before entering the coupling transformer.

- ✚ **Blocking inductors:** These have to be designed for the power frequency (to prevent saturation) and for the power current (to prevent voltage-drops). Blocking inductors need to block the modulation frequency, and therefore the self-resonant point needs to be above that frequency. Air-core inductors are well suited to this application.
- ✚ **Resistors:** For power-line coupler circuits, in general, one strives to avoid using resistors, as a resistor, in essence, implies a loss of power, either of the communication signal or the power waveform. A typical coupling circuit employs generally both coupling capacitors and a coupling Transformer which are designed for PLC channel measurements. The circuit employs high voltage capacitors to filter out the 50/60 Hz high voltage waveform, a broadband transformer, and a combination of diodes for over voltage protection.

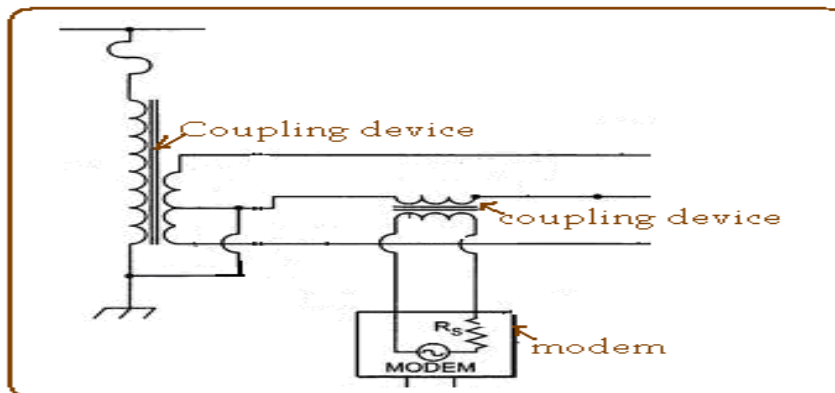

Figure 5.5 Broadband power line coupling circuit (transformer coupling)

**Note:** - The coupling circuit should not influence the actual scattering parameters of the PLC channel during measurements.

The effect of coupling circuit needs to be compensated in the measured data. This can be done by post processing of the measurement data, once the transfer function of the coupling circuit is known.

### Inductive Coupling

In the inductive coupling, PLC signal current is injected into the power distribution lines. This is achieved through an inductive transformer coupler using appropriate high-frequency ferrites. The inductive injection method is most effective when the mains impedance is low at the signal injection point. This is typically the case when injecting the signal into a bus network where several power cables are connected together.

Connecting several power cables to a single point or bus effectively results in a parallel connection of the individual cable impedances. This results in low input impedance.

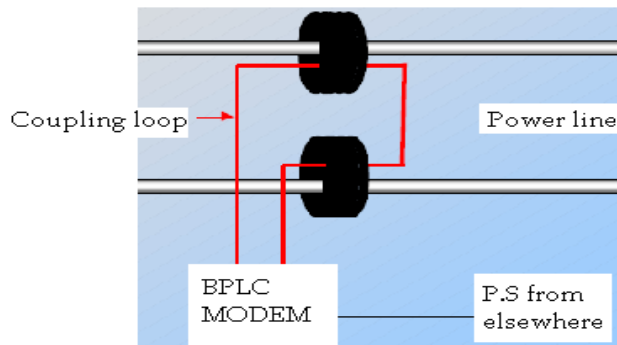

Figure 5.6 Inductive coupling of BPLC using ferrites.

The inductive coupling is often the preferred method for coupling due to its better Performance in low impedance situations, lower radiation from power mains and its simplicity to use Inductive coupling employs ferrite rings (acting as transformers) to inject the communication signal into the mains. In this case, there is no galvanic connection between the power grid and the PLC equipment, which is handy, and also safe from the practical point of view.

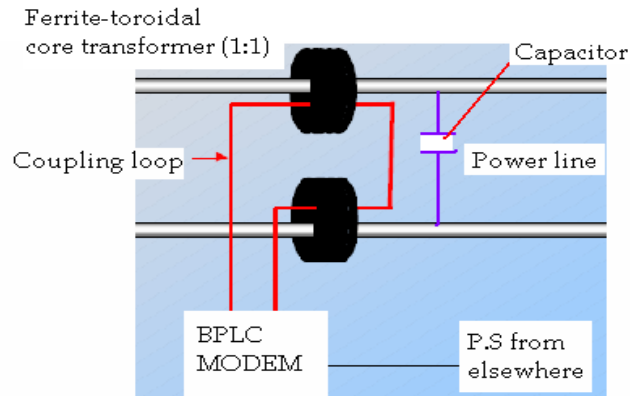

Figure 5.7 Inductive coupling schemes for BPLC with ferrites and capacitors

*Note:* In general from figure 5.5, 5.6 and 5.7, coupling circuits are an important component in power line communication systems. In order to design an optimized interface between the power and BPLC system, the components of the circuitry must be carefully chosen.

### 5.5 Line traps broadband power line communications system.

Broadband power Line Communication (BPLC) is a common method of Power System Communication, such as tele-protection, voice and data communication, etc. It has developed the reputation of being one of the most economical and reliable forms of Communication and versatile in its application.

A filter consisting of a series inductance shunted by a tuning capacitor, inserted in series with the power or telephone line for a carrier-current system to minimize the effects of variations in line attenuation and reduce carrier energy loss [34]. Line Traps as figure 5.8 below are connected in series with HV transmission lines. The main function of the Line Trap is to present high impedance at the carrier frequency band while introducing negligible impedance at the power frequency. The high impedance limits the attenuation of the carrier signal within

the power system by preventing the carrier signal from being dissipated in the substation grounded in the event of a fault outside the carrier transmission path dissipated in a tap line or a branch of the main transmission path.

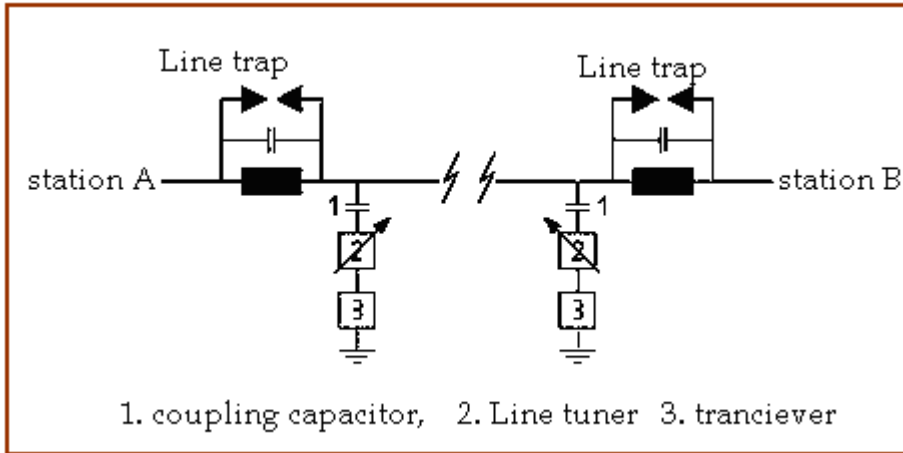

Figure 5.8 Line traps of BPLC systems

## Chapter-Four

### Orthogonal frequency division multiplexing in BPLC

The concept of using parallel data transmission by means of frequency division multiplexing (FDM) was published in middle of 60's by Chang [3]. Some early developers can be traced back in the 50's a U.S. patent was filled and issued in January, 1970. The idea was to use parallel data streams and frequency division multiplexing with overlapping subchannels to avoid the use of high speed equalization, and to combat impulsive noise, and multipath distortion as well as to fully use the available bandwidth. The initial applications were in the military communications. In the telecommunications field, the term of discrete Multitone, multi-channel modulation and multi-carrier modulation (MCM) are widely used and sometimes they are interchangeable with OFDM. In OFDM, each carrier is orthogonal to all other carriers. However, this condition is not always maintained in MCM. OFDM is an optimum version of multi carrier transmission schemes. The comparison is indicated as in the figure 4.1 below.

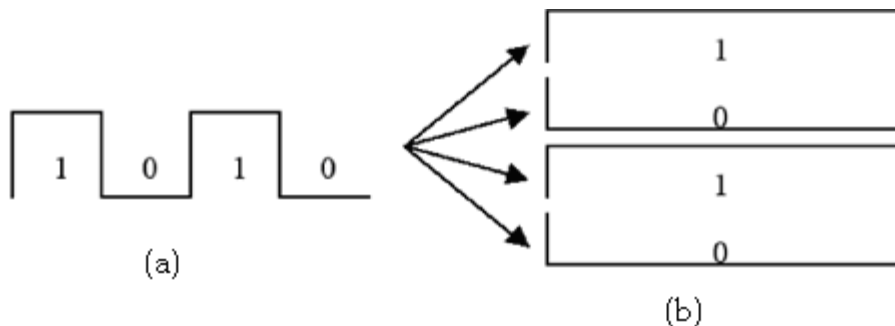

Figure 4.1 Transmission of BPLC signals (a) Traditional,  
(b) OFDM transmissions

Orthogonal frequency division multiplexing is a multicarrier communication system, which follows a process of dividing the total signal bandwidth into number of subcarriers and information is transmitted on each of the subcarriers. Unlike the conventional multicarrier communication scheme in which spectrum of each subcarrier

is non-overlapping and bandpass filtering is used to extract the frequency of interest, in OFDM the frequency spacing between subcarriers is selected such that the subcarriers are mathematically orthogonal to each others. The spectra of subcarriers overlap each other but individual subcarrier can be extracted by baseband processing. This overlapping property makes OFDM more spectral efficient than the conventional multicarrier communication scheme. By contrast, during the  $N$ -symbol period of the conventional serial system, each OFDM modulator carries only one symbol, and the error burst causes severe signal degradation of the duration of  $k$ -serial symbols. This degradation is shown crosshatched. However, if the error burst is only a small fraction of the symbol period then each of the OFDM symbols may only be slightly affected by the fade and they can still be correctly demodulated? Thus while the serial system exhibits an error burst, no errors or few errors may occur using the OFDM approach.

A further advantage of OFDM is that because the symbol period has been increased, the channel delay spread is significantly a shorter fraction of a symbol period than in the serial system, potentially rendering the system less sensitive to ISI than the conventional serial system. A disadvantage of the OFDM approach is the increased complexity over the conventional system caused by employing  $N$  modulators and filters at the transmitter and  $N$  demodulators and filters at the receiver. However, this complexity can be removed by the use of the FFT and IFFT at the receiver and transmitter, respectively. The narrow band technology uses simple digital modulation schemes, such as frequency shift keying (FSK). With the advent of high-speed digital signal processors, advanced digital modulation techniques can be implemented.

Basically the broadband power line communication systems use the following modulation schemes.

- GMSK (Gaussian minimum shift keying), It uses a Single Carrier Version of PLC providing low bandwidths which is less than 1 MB.
- CDM (code division multiplexing), Used with the Single Carrier Version of PLC providing low bandwidths <1 MB.

- OFDM (orthogonal frequency division multiple access), which is the Multi Carrier version of PLC providing a bandwidth of around 45 MB.

OFDM is used by power line devices to extend internet connections and other high speed services to other rooms in a home through its power wiring.

The multi-carrier modulation represents a group of very popular and promising modulations whose basic feature is the parallel transmission of symbol's blocks on different sub-carriers occupying a sub-band which is so narrow that the associated sub-channel has a flat frequency response. Probably the best known representative is DMT modulation used in ADSL and partially also in VDSL technology. In the field of BPLC technologies this kind of modulations is included in the form of OFDM modulation.

The orthogonal frequency division multiplexing (OFDM) transmission scheme is suitable for frequency-selective channels because of its ability to cope with this feature by dividing the available bandwidth into  $N$  equally spaced narrowband sub-channels [22].

Each narrowband sub-carrier can be modulated using various modulation formats; BPSK, QPSK and DPSK are commonly used in broadband power line communication systems. The attenuation and group delay are constant within each channel due to their narrowness. To suppress the intersymbol interference, a cyclic prefix must be inserted in each block of symbols. Its duration depends on the channel memory that is quite long in BPLC channels and in this way the cyclic prefix reduces the bandwidth efficiency. All these mentioned effects are getting more crucial with the length of the OFDM symbol. To overcome this problem, a shorter cyclic prefix in connection with partial equalization can be used. This technique is called channel shortening.

Because of the high spectral efficiency, robustness against channel distortion, high flexibility and adaptability, it is expected that the OFDM will become the most favorable modulation scheme in all BPLC application fields.

In multi-carrier transmission system each sub-channel is characterized by a SNR of its own. The channel capacity of the entire system in bits per transmission is given by

$$R = \frac{1}{N} \sum_{n=1}^N R_n \implies \frac{1}{2N} \sum_{n=1}^N \log_2 \left( 1 + \frac{P_n}{\Gamma \sigma_n^2} \right) \implies \frac{1}{2N} \log_2 \left[ \prod_{n=1}^N \left( 1 + \frac{P_n}{\Gamma \sigma_n^2} \right) \right]^{\frac{1}{N}} \quad 4.1$$

Let  $(SNR)_{overall}$  denote the overall SNR of the entire system. R is expressed in bits per

$$\text{Transmission a } R = \frac{1}{2} \log_2 \left( 1 + \frac{(SNR)_{overall}}{\Gamma} \right) \quad 4.2$$

from equations above;

$$(SNR)_{overall} = \Gamma \left( \prod_{n=1}^N \left( 1 + \frac{P_n}{\Gamma \sigma_n^2} \right)^{\frac{1}{N}} - 1 \right) \text{ and approximated as}$$

$$SNR = \prod_{n=1}^N \left( \frac{P_n}{\sigma_n^2} \right)^{\frac{1}{N}} \quad 4.3$$

**Note:**

- The overall systems can be characterized by a SNR that is the geometric mean of the SNR of the individual sub-channels.
- The overall data rate is the sum of the individual data rates over the sub-channels operating in parallel.

**4.1 Generation of OFDM signals for BPLC systems**

A baseband OFDM symbol can be generated in the digital domain before modulating on a carrier for transmission. To generate a baseband OFDM symbol the sequence figure 4.2 is applied, a serial digitized data stream is first modulated using common modulation schemes such as the binary phase shift keying, quadrature phase shift keying, and differential phase shift keying [23].

These data symbols are then converted to parallel streams before modulating subcarriers. Subcarriers are sampled with sampling rate  $N/T_s$ , where  $N$  is the number of subcarriers and  $T_s$  is the OFDM symbol duration. The frequency separation between

two adjacent subcarriers is  $2\pi/N$ . Finally, samples on each subcarrier are summed together to form an OFDM sample.

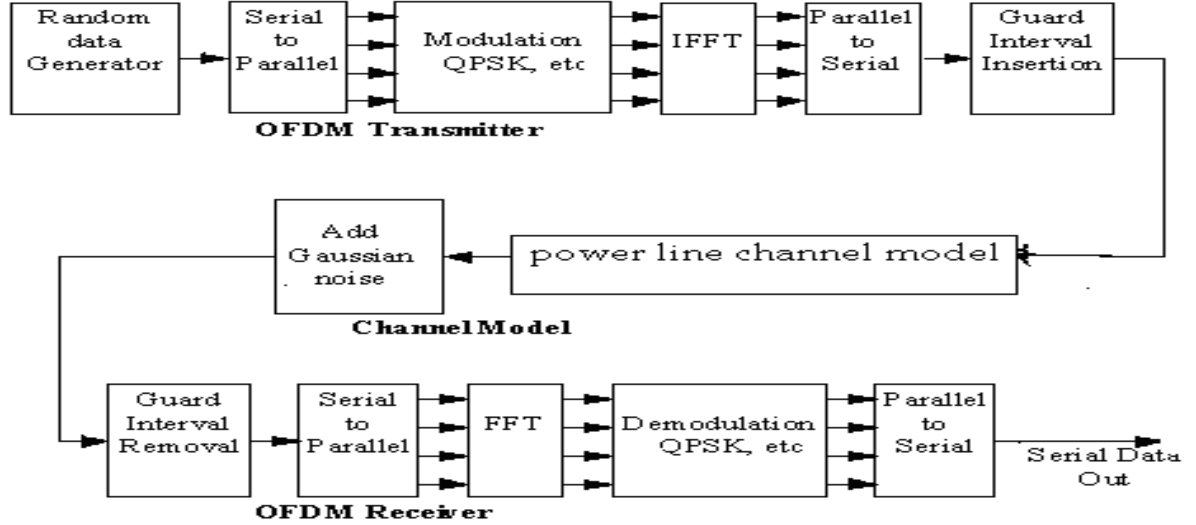

Figure 4.2 block diagrams of OFDM systems for BPLC application

An OFDM symbol generated by an  $N$ -subcarrier OFDM system consists of  $N$  samples and the  $m$ -th sample of an OFDM symbol is given by.

$$x_m = \sum (X_n e^{j\frac{2\pi mn}{N}}) \quad 0 \leq m \leq N-1 \quad 4.4$$

where  $X_n$  is the transmitted data symbol on the  $n$ th carrier. Equation (4.4) is equivalent to the  $N$ -point inverse discrete Fourier transform (IDFT) operation on the data sequence with the omission of a scaling factor. It is well known that IDFT can be implemented efficiently using inverse fast Fourier transform (IFFT). Therefore, in practice, the IFFT is performed on the data sequence at an OFDM transmitter for baseband modulation and the FFT is performed at an OFDM receiver for baseband demodulation. Size of FFT and IFFT is  $N$ , which is equal to the number of sub channels available for transmission, but all of the channels needs to be active. The sub-channel bandwidth is given by

$$f_{sc} = \frac{1}{T_s} = \frac{f_{samp}}{N} \quad 4.5$$

where  $f_{\text{samp}}$  is the sample rate and  $T_s$  is the symbol time. Finally, a baseband OFDM symbol is modulated by a carrier to become a bandpass signal and transmitted to the receiver. In the frequency domain, this corresponds to translating all the subcarriers from baseband to the carrier frequency simultaneously.

## **4.2 Orthogonal Frequency-Division Multiplexing**

OFDM belongs to a family of transmission schemes called multicarrier modulation, which is based on the idea of dividing a given high-bit-rate data stream into several parallel lower bit-rate streams and modulating each stream on separate carrier often called subcarriers, or tones. Multicarrier modulation schemes eliminate or minimize intersymbol interference (ISI) by making the symbol time large enough so that the channel-induced delays. Splitting the data stream into many parallel streams increases the symbol duration of each stream such that the delay spread is only a small fraction of the symbol duration. It is a spectrally efficient version of multicarrier modulation, where the subcarriers are selected such that they are all orthogonal to one another over the symbol duration, thereby avoiding the need to have non-overlapping subcarrier channels to eliminate intercarrier interference [24]. Choosing the first subcarrier to have a frequency such that it has an integer number of cycles in a symbol period, and setting the spacing between adjacent subcarriers (subcarrier bandwidth) to be  $BSC = B/N$ , where  $B$  is the nominal bandwidth (equal to data rate), and  $N$  is the number of subcarriers, ensures that all tones are orthogonal to one another over the symbol period. It can be shown that the OFDM signal is equivalent to the inverse discrete Fourier transform (IDFT) of the data sequence block taken  $N$  at a time. This makes it extremely easy to implement OFDM transmitters and receivers in discrete time using IFFT (inverse fast Fourier) and FFT, respectively.

In order to completely eliminate ISI, guard intervals are used between OFDM symbols. By making the guard interval larger than the expected multipath delay spread, ISI can be completely eliminated. Adding a guard interval, however, implies power wastage and a decrease in bandwidth efficiency. The amount of power wasted depends on how

large a fraction of the OFDM symbol duration the guard time is. Therefore, the larger the symbol period or a given data rate, this means more subcarriers, the smaller the loss of power and bandwidth efficiency.

OFDM sends multiple high-speed signals concurrently on specially computed orthogonal carrier frequencies. The result is much more efficient use of bandwidth as well as robust communications during noise and other interferences.

Power lines differ from telephone lines in that they are bus-type wiring and a great variety of device are connected to them. Thus, the impedance, transmission line loss and noise level of power line fluctuate greatly according to how the devices are connected and their operating conditions. To realize stable high speed communication even under such circumstances requires the use of technology that is employed in wireless and wire line communication, which is OFDM technology.

The primary advantages of OFDM modulation system is its bandwidth efficiency. It is the ratio of the data rate in bits per second to the efficiency utilized channel bandwidth.

The second objective is to achieve this bandwidth efficiency at minimum practical expenditure of average signal power or equivalently in a channel perturbed by additive white Gaussian noise, a minimum practical expenditure of average signal to noise ratio.

With the data rate denoted by  $R_b$  and the effectively used channel bandwidth by  $B$ , we

may express the bandwidth efficiency,  $\rho$ , as  $\rho = \frac{R_b}{B}$  bits/s/Hz.

### **4.3 Mathematical description of OFDM**

The basic idea of OFDM is to divide the available spectrum into several subchannels (Subcarriers) by making all subchannels narrowband, they experience almost flat fading, which makes equalization very simple or may not require equalization [25].

If  $N$  sub-carriers are used, and each sub-carrier is modulated using  $M$  alternative symbols, the OFDM symbol alphabet consists of  $M^N$  combined symbols. The low-pass equivalent OFDM signal is expressed as

$$v(t) = \sum_{k=0}^{N-1} (X_k e^{j2\pi k \frac{t}{T}}) \quad 0 \leq t \leq T \quad 4.6$$

where  $\{X_k\}$  are the data symbols,  $N$  is the number of sub-carriers, and  $T$  is the OFDM symbol time. The sub-carrier spacing of  $\frac{1}{T}$  makes them orthogonal over each symbol period; this property is expressed as,

$$\begin{aligned} v(t) &= \frac{1}{T} \int_0^T (e^{j2\pi k_1 \frac{t}{T}})^* (e^{j2\pi k_2 \frac{t}{T}}) dt \\ \Rightarrow \frac{1}{T} \int_0^T e^{j2\pi(k_2-k_1)\frac{t}{T}} dt &= \begin{cases} 1, k_1 = k_2 \\ 0, k_1 \neq k_2 \end{cases} \end{aligned} \quad 4.7$$

Where  $(\cdot)^*$  denotes the complex conjugate operator.

To avoid intersymbol interference in multipath fading channels, a guard interval of length  $T_g$  is inserted prior to the OFDM block. During this interval, a cyclic prefix is transmitted such that the signal in the interval  $-T_g \leq t \leq 0$  equals the signal in the interval  $(T - T_g) \leq t < T$ . The OFDM signal with cyclic prefix is thus;

$$v(t) = \sum_{k=0}^{N-1} X_k e^{j2\pi k \frac{t}{T}}, -T_g \leq t < T \quad 4.8$$

The low-pass signal above can be either real or complex-valued. Real-valued low-pass equivalent signals are typically transmitted at baseband wireline applications such as DSL and power line communications use this approach

In general, the transmitted signal can be represented as;

$$S(t) = \frac{1}{2} \Re \{ v(t) e^{j2\pi f_c t} \}$$

$$S(t) \Rightarrow \sum_{k=0}^{N-1} |X_k| \cos(2\pi \left[ f_c + \frac{k}{T} \right] t + \arg[X_k]) \quad 4.9$$

This can be represented partially in the following figure 4.3 below.

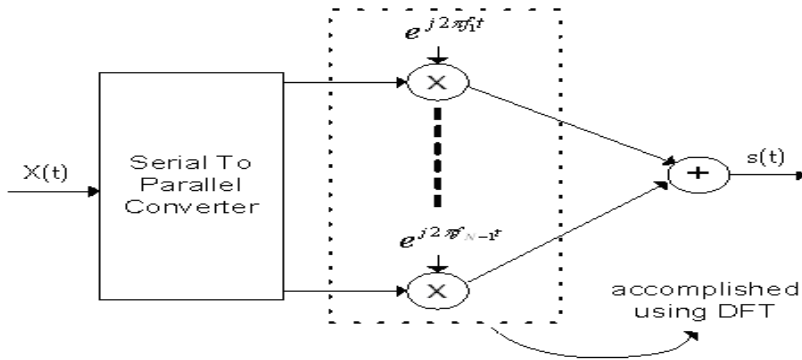

Fig 4.3 Spectrum analysis OFDM signals for BPLC applications

#### 4.4 Advantages of OFDM on BPLC systems

It gives a great advantage when OFDM are used in broadband power line communication systems. Some of the advantages are the following [26].

1. Very good at mitigating the effect of in-band narrowband interference,
2. High bandwidth efficiency,
3. Scalable to high data rates,
4. Flexible and can be made adaptive;
5. Does not have problems of channel equalization.

If the OFDM symbol duration remains the same, the duration between two samples decreases as a result. This implies an increase in the OFDM signal bandwidth as in the figure 4.4 below. On the other hand, if the OFDM signal bandwidth is fixed, then increasing the number of sub carriers decreases the frequency spacing between two subcarriers, which in turn increases the symbol duration. The duration between two samples remain the same in this case.

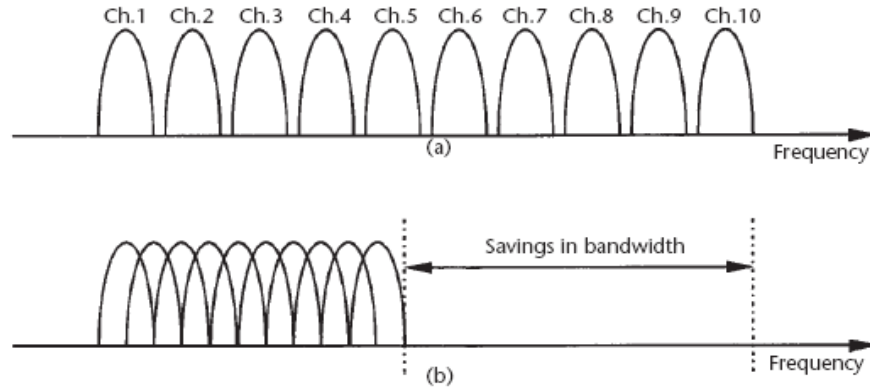

Figure 4.4 Concept of the OFDM signal: (a) conventional multi-carrier, and (b) Orthogonal multi-carrier modulation technique.

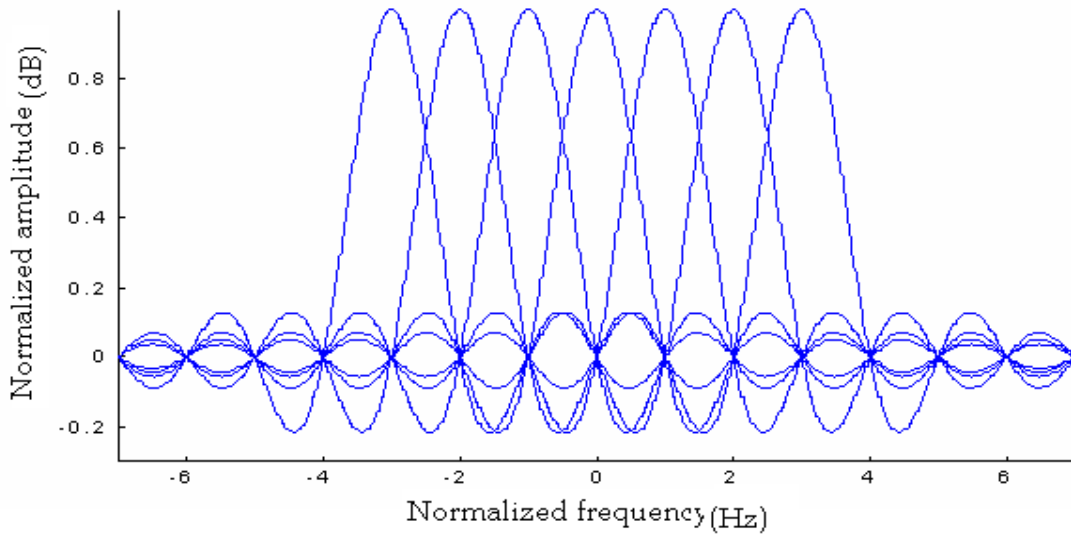

Figure 4.5 Structures of OFDM carrier signals

From the above figure 4.5, Orthogonality makes it possible in OFDM to arrange the sub carriers in such a way that the sidebands of the individual carriers overlap and still the signals are received at the receiver without being interfered by ICI.

#### 4.5 Disadvantages of OFDM System for BPLC services

Even though OFDM systems have great advantages on the BPLC system, it has the following difficulties.

- OFDM is more sensitive to frequency offset and phase noise.
- Strict Synchronization Requirement
- Co-Channel Interference in Cellular OFDM
- OFDM has a relatively large peak-to-average-power ratio, which tends to reduce the power efficiency of the radio frequency (RF) amplifier.

#### **4.6 Guard Period insertion and the BPLC systems**

The time-domain counterpart of the multipath is the ISI or smearing of one symbol into the next. OFDM gracefully handles this type of multipath distortion by adding a "guard interval" to each symbol. This guard interval is typically a cyclic or periodic extension of the basic OFDM symbol. In other words, it looks like the rest of the symbol, but conveys no 'new' information [27].

Since no new information is conveyed, the receiver can ignore the guard interval and still be able to separate and decode the subcarriers. When the guard interval is designed to be longer than any smearing due to the multipath channel, the receiver is able to eliminate ISI distortion by discarding the unneeded guard interval. Hence, ISI is removed with virtually no added receiver complexity.

It is important to note that discarding the guard interval does have an impact on the noise performance since it reduces the amount of energy available at the receiver for channel symbol decoding. In addition, it reduces the data rate since no new information is contained in the added guard interval. Thus a good system design will make the guard interval as short as possible while maintaining sufficient multipath protection.

Since OFDM uses a bundle of narrowband subcarriers, it obtains high data rates with a relatively long symbol period because the frequency width of the subcarrier is inversely proportional to the symbol duration. Consequently, adding a short guard interval has little impact on the data rate. For an OFDM transmitter with  $N$  subcarriers, if the duration of a data symbol is  $T_0$ , the duration of the OFDM symbol at the output of the

transmitter is  $T_s = T_0 N$ . Thus if the delay spread of a multipath channel is greater than  $T_0$  but less than  $T_s$ , as in the figure 4.6 below.

The data symbol in the serial data stream will experience frequency-selective fading while the data symbol on each subcarrier will experience only flat-fading. Moreover, to further reduce the ISI, a guard time is inserted at the beginning of each OFDM symbol before transmission as shown in Figure 4.6, and removed at the receiver before the FFT operation.

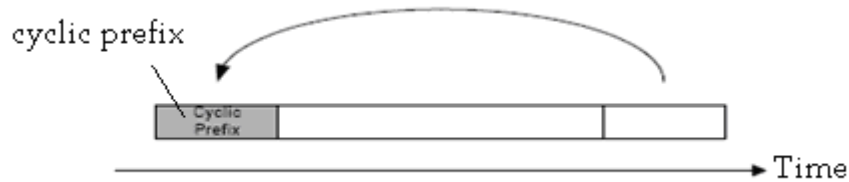

Figure 4.6 Cyclic prefix is a copy of the last part of OFDM symbol

If the guard time is chosen such that its duration is longer than the delay spread, the ISI can be completely eliminated. Figure 4.7 illustrates the concept of guard time insertion in an OFDM system. One of the most important properties of OFDM transmissions is its high level of robustness against multipath delay spread. This is a result of the long symbol period used, which minimizes the inter-symbol interference. The level of multipath robustness can be further increased by the addition of a guard period between transmitted symbols. The guard period allows time for multipath signals from the previous symbol to die away before the information from the current symbol is gathered. The most effective guard period to use is a cyclic extension of the symbol. If a mirror in time, of the end of the symbol waveform is put at the start of the symbol as the guard period, this effectively extends the length of the symbol, while maintaining the orthogonality of the waveform. Using this cyclic extended symbol the samples required for performing the FFT (to decode the symbol), can be taken anywhere over the length of the symbol which multipath immunity as well as symbol time synchronization tolerance.

A Guard time is introduced at the end of each OFDM symbol for protection against multipath and it is “cyclically extended” to avoid Inter-Carrier Interference (ICI). Guard time must be greater than multipath delay spread, to guarantee zero ISI & ICI which is shown in figure 4.7 below.

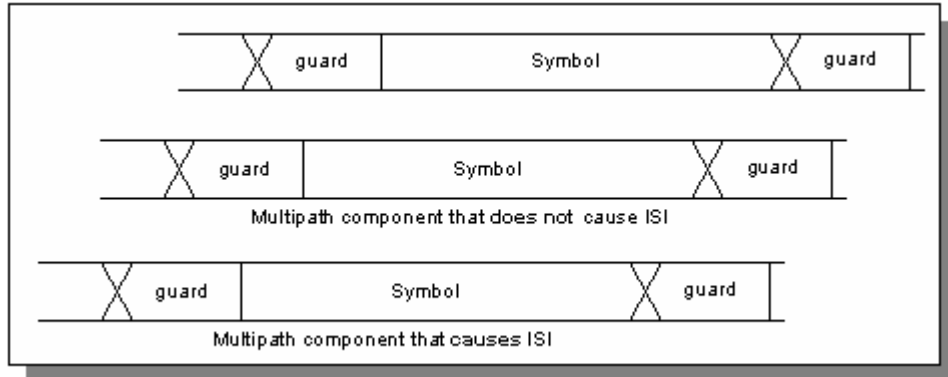

Figure 4.7 Guard length arrangement and symbol spacing of OFDM systems

#### **4.7 OFDM and broadband power-line noise**

With the convergence of broadcast entertainment and broadband access, the demand to send digital voice, video and Internet data within the home will increase. The cost of installing in-home wires to support this is expensive, disruptive and time consuming. With multiple outlets in every room, residential power lines are already the most pervasive network in the world. However, communication on the AC power line is extremely difficult because of its unfavorable communication characteristics, specifically line noise.

Rather than fighting through the noise, some companies are working with a technology that lets signals travel around the noise.

Orthogonal Frequency Division Multiplexing (OFDM), which is the foundation of the HomePlug Powerline Alliance industry specification, is one such approach.

OFDM is a discrete multitone technology in which numerous signals of different frequencies, called carriers, are combined to form a single signal for transmission. Prior to

combining, each carrier is first "phase shifted," or modulated, for the purpose of representing data bits. By modulating data bits on individual signals prior to combining them, many data bits can be transmitted over a small amount of time. Maximizing bits while minimizing the time to transport those bits increases throughput. After each carrier is modulated, the signals are sent through the OFDM engine, which combines the carriers into one signal that represents all the bits to be transmitted. As an example, HomePlug technology modulates data bits on 84 individual carrier frequencies ranging from 4 MHz and above.

HomePlug technology enhances OFDM's basic functionality by comparing each individual modulated carrier with the characteristics of the power line medium. It then determines which specific carriers will experience high attenuation or noise impulses that will affect their abilities to transport data successfully. HomePlug technology automatically adapts to characteristics of the medium by determining a threshold in which successful communication can occur. If the attenuation or noise is too great for successful communication at a specific frequency, HomePlug technology will not use carriers in that frequency.

#### **4.8 Design Requirements and its parameters OFDM Systems in BPLC**

The design parameters of OFDM systems are derived according to the following system requirements [25].

- Available bandwidth: Bandwidth is always the scarce resource, so the mother of the system design should be the available for bandwidth for operation.
- The amount of bandwidth will play a significant role in determining number of subcarriers, because with a large bandwidth, we can easily fit in large number of subcarriers with reasonable guard space.

- Required bit rate: The overall system should be able to support the data rate required by the users. For example, to support broadband power line communication, the system should operate up to 45 Mbps.
- Tolerable delay spread: Tolerable delay spread will depend on the user environment. The length of CP (cyclic prefix) should be determined according to the tolerable delay spread.

Based on the requirements mentioned above, the OFDM systems parameters are the following

- Number of subcarriers: Increasing number of subcarriers will reduce the data rate via each sub carrier, which will make sure that the relative amount of dispersion in time caused by multipath delay will be decreased. But when there are large numbers of subcarriers, the synchronization at the receiver side will be extremely difficult.
- Guard time (CP interval) and symbol duration: A good ratio between the CP interval and symbol duration should be found, so that all multi-paths are resolved and not significant amount of energy is lost due to CP. As a thumb rule, the CP interval must be two to four times larger than the Root-Mean-Square (RMS) delay spread.

Symbol duration should be much larger than the guard time to minimize the loss of SNR, but within reasonable amount. It cannot be arbitrarily large, because larger symbol time means that more subcarriers can fit within the symbol time. More subcarriers increase the signal processing load at both the transmitter and receiver, increasing the cost and complexity of the resulting device.

- Sub-carrier spacing: Sub-carrier spacing must be kept at a level so that synchronization is achievable. This parameter will largely depend on available bandwidth and the required number of sub-channels.
- Modulation type per sub-carrier: This is trivial, because different modulation scheme (BPSK, DPSK, and QPSK) will give different performance. Adaptive modulation and bit loading may be needed depending on the performance requirement. It is interesting to note that the performance of OFDM systems with differential modulation compares quite well with systems using non-differential and

coherent demodulation. Furthermore, the computation complexity in the demodulation process is quite low for differential modulations.

#### **4.9 Probability of error for broadband power line communication signals**

A major goal of digital data transmission systems is the optimum design of the receiver so as to minimize the average probability of the symbol error in the presence of additive white Gaussian noise (AWGN) in broadband power line communication systems [28]. OFDM uses the following modulation techniques, BPSK, QPSK, and DPSK.

The various forms of phase shift keying (PSK) gained widespread use when the transmission of data at higher rates is required. The popularity of BPSK (binary PSK) is in its robust performance in low signal-to-noise environments. BPSK uses phase inversion (0 and 180 degree phase shift) as the two binary states. Such changes are easily detected using conventional RF mixers, so BPSK provided a significant performance improvement using conventional RF circuitry. The simplicity of BPSK was exploited to make extremely low cost paging receivers when that application became popular. Many of those receivers used direct conversion architecture, the earliest large-scale application of that technique.

Another popular member of the PSK family is QPSK (quaternary PSK). This modulation method uses 90-degree increments in phase, resulting in four possible logic states at any instant. This increases the data rate transmission within the same bandwidth as BPSK, but with additional complexity in its generation and detection. The easiest system architecture for QPSK is actually two BPSK modulators or demodulators. A single local oscillator is common to both, but with a phase shift of 90 degrees between the inputs to each BPSK unit. There are many variations that affect the overall performance of these systems, briefly, orthogonal frequency division multiplexing (OFDM) is the use of one of the above modulation types on each of several carriers. Adjacent channel carriers are shifted by 90 degrees relative phase (orthogonal) to minimize interaction. Initially used for multiple independent signals, OFDM is seeing extensive use in robust high data rate applications. OFDM solves the problem by allowing a high-speed data stream to be

divided into multiple channels, each of which has a low enough data rate to be transmitted reliably at the operating frequency.

In BPSK, the pair of signals  $s_1(t)$  and  $s_2(t)$  are used to represent binary symbols 1 and 0, respectively, is defined by  $s_1(t) = \sqrt{\frac{2E_b}{T_b}} \cos(2\pi f_c t)$

$$s_1(t) = \sqrt{\frac{2E_b}{T_b}} \cos(2\pi f_c t)$$

$$s_2(t) = \sqrt{\frac{2E_b}{T_b}} \cos(2\pi f_c t + \pi) = -\sqrt{\frac{2E_b}{T_b}} \cos(2\pi f_c t), \quad \text{where } 0 \leq t \leq T_b \quad \text{and } E_b \text{ is the}$$

transmitted signal energy per bit.

To calculate the probability of making an error of the first kind, it is noted that  $Z_1$ :

$0 < x_1 < \infty$ ; Where the observable element  $x_1$  is related to the received signal  $x(t)$

$$\text{by } x_1 = \int_0^{T_b} x(t) \phi_1(t) dt$$

The conditional probability density function of random variable  $x_1$ , given that symbol 0

[i.e., signal  $s_2(t)$  was transmitted, is defined by

$$\begin{aligned} f_{x_1}(x / 0) &= \frac{1}{\sqrt{\pi N_0}} \exp\left[-\frac{1}{N_0} (x_1 - s_{21})^2\right] \\ &\Rightarrow \frac{1}{\sqrt{\pi N_0}} \exp\left[-\frac{1}{N_0} (x_1 + \sqrt{E_b})^2\right] \end{aligned} \quad 4.10$$

The conditional probability of the receiver deciding in favor symbol 1, given that symbol 0 was transmitted, is therefore

$$P_{10} = \int_0^{\infty} f_{x_1}(x_1 / 0) dx_1 = \frac{1}{\sqrt{\pi N_0}} \int_0^{\infty} \exp\left[-\frac{1}{N_0} (x_1 + \sqrt{E_b})^2\right] dx_1 \quad 4.11$$

Putting  $z = \frac{1}{\sqrt{N_0}} (x_1 + \sqrt{E_b})$  and changing the variable of integration from  $x_1$  to  $z$ , it

can be rewritten in compact form

$$P_{10} = \frac{1}{\sqrt{\pi}} \int_0^{\infty} \sqrt{E_b / N_0} \exp(-z^2) dz = \frac{1}{2} \operatorname{erfc}\left(\sqrt{\frac{E_b}{N_0}}\right), \quad 4.12$$

where  $\text{erfc}(\cdot)$  is the complementary error function. Similarly  $p_{01}$  can be calculate, thus averaging the conditional error probability  $p_{10}$  and  $p_{01}$ , it is found that the average probability of the symbol error, or equivalently, the bit error rate for

$$\text{BPSK is } p_e = \frac{1}{2} \text{erfc} \left( \sqrt{\frac{E_b}{N_0}} \right) \quad 4.13$$

As the transmitted signal energy per bit is increased, for the specified noise spectral density  $N_0$ , the message points corresponding to symbols 1 and 0 move further apart, and the average probability of error  $P_e$  is correspondingly reduced.

As BPSK, in QPSK information carried by the transmitted signal is contained in the phase. In particular, the phase of the carrier takes on one of four equally spaced values, such as  $\pi/4, 3\pi/4, 5\pi/4,$  and  $7\pi/4$ .

$$s_i(t) = \begin{cases} \sqrt{\frac{2E}{T}} \cos \left[ 2\pi f_c t + (2i-1)\frac{\pi}{4} \right], & 0 \leq t \leq T \\ 0, & \text{elsewhere} \end{cases} \quad 4.14$$

Where  $i=1, 2, 3, 4$ ;  $E$  is the transmitted energy per symbol,  $T$  the symbol duration and the carrier frequency  $f_c$ .

By assigning two base functions, the following four message points and associated vectors are defined,

$$s_i = \begin{bmatrix} \sqrt{E} \cos \left( (2i-1)\frac{\pi}{4} \right) \\ -\sqrt{E} \sin \left( (2i-1)\frac{\pi}{4} \right) \end{bmatrix}, \quad i=1, 2, 3, 4 \quad 4.15$$

By applying the error calculation formulas the average probability of symbol error in terms of the signal to noise ratio is as follows.

$$p_e \cong \operatorname{erfc}\left(\sqrt{\frac{E_b}{N_0}}\right) \quad \text{And the BER} = \frac{1}{2} \operatorname{erfc}\left(\sqrt{\frac{E_b}{N_0}}\right) \quad 4.16$$

Here QPSK system achieves the same average probability of bit error as BPSK system for the same  $\frac{E_b}{N_0}$ , but uses only half the channel band width. So this indicates QPSK system transmits information at twice the bit rate of BPSK for the same channel bandwidth and average probability of error. So QPSK uses channel band width better than BPSK but the power needed become maximum so BPSK is preferable.

In the case of DPSK, It is as system that uses changes in phase to indicate values of the data. It is another example of non-coherent DPSK orthogonal modulation. Its bit error

$$p_e \cong \frac{1}{2} \exp\left(-\frac{E_b}{N_0}\right) \quad 4.17$$

rate is given by

The above equations, eq. 4.13, eq. 4.16 and eq. 4.17 used as a reference point for a practical broadband power line communication systems.

#### 4.10 Design procedures of OFDM Signals for BPLC applications

The steps involved in the design of an OFDM system are given below:

- 1) Let 'B' be the total available bandwidth
- 2) Let the maximum delay spread of the channel be  $t_d$  seconds
- 3) To prevent ISI, choose guard interval 'T<sub>g</sub>' for OFDM symbol much greater than the maximum delay spread 't<sub>d</sub>' say  $T_g = 4 \times t_d$ .
- 4) To minimize the signal-to-noise ratio (SNR) loss due to the guard time, the symbol duration should be much larger than the guard time. As a rule of thumb, the OFDM symbol duration  $T_{os}$  should be at least five times the guard time, i.e.  $T_{os} \geq 5 T_g$ , so it can be chosen as  $T_{os} = 8 \times T_g$ .
- 5) To reduce the overhead introduced by cyclic prefix, choose OFDM symbol time 'T<sub>s</sub>' much greater than the guard time 'T<sub>g</sub>'

- 6) Then Subcarrier spacing,  $f_d = 1/T_{os}$
- 7) Total symbol time,  $T_s = T_{os} + T_g$
- 8) Number of subcarriers,  $N = B/f_d$

## Chapter-Six

### Results of the thesis and conclusions

#### 6.1 Simulation results of the thesis

The performance comparisons of broadband power line communications using OFDM systems enables to access a better broadband service with a minimum of error than other different broadband solutions. This is done using a mat lab as a simulator. The matlab simulator accepts inputs of text or audio files as well as binary, sinusoidal, or random data, and then it generates the corresponding OFDM transmission signals, and simulates a channel by modeling the power line, attempts to recover the input data, and performs an analysis to determine the transmission error rate. This error rate comparison among OFDM modulation techniques can be performed among BPSK, QPSK and DPSK systems. These simulations are dynamic, allowing the user to set a decision, determining the characteristics of the communication system and to select the best for broadband power line communications by minimizing the interference. This can be generalized by convolving power line model impulse response to the OFDM output and the AWGN is applied for error calculations as indicated in figure 6.1 below

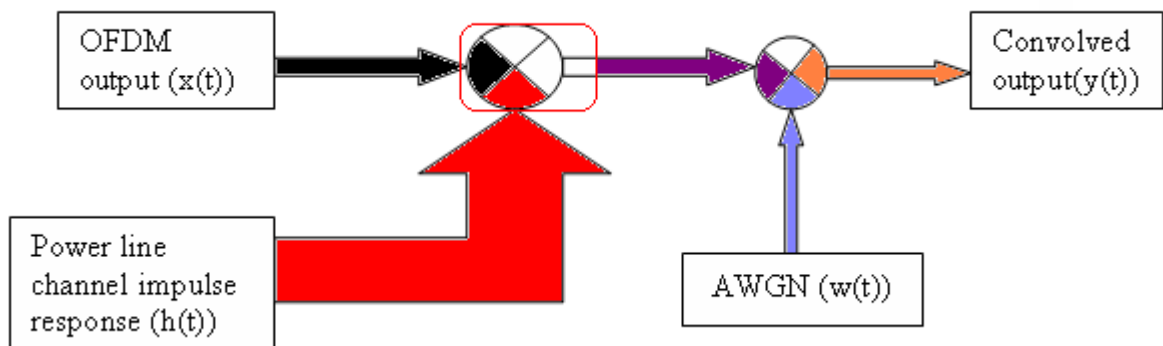

Figure 6.1 Structural arrangements of BPLC systems

As in figure 6.1 above the response  $y(t)$  of a system is defined in terms of the impulse response of the power line channel  $h(t)$  by

$$Y(t) = x(t) * h(t) + w(t) \quad , \text{ where } * \text{ is convolution operator}$$

$$Y(t) = \int x(\tau) h(t-\tau) d\tau \quad t, \text{ response time and } \tau, \text{ excitation time} \quad 6.1$$

The input signal which we used is the random data generated by  $\text{randn}()$  function of the matlab, and limit the data to its maximum value, depending on the requirement.

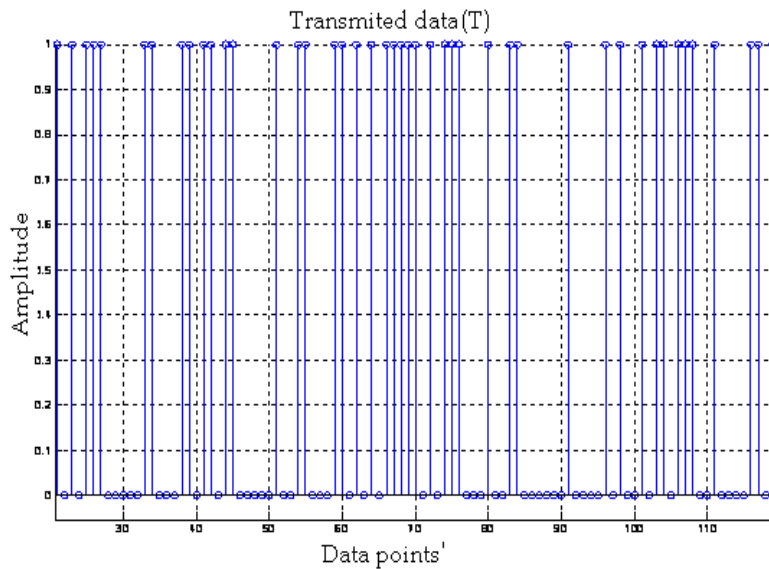

(a)

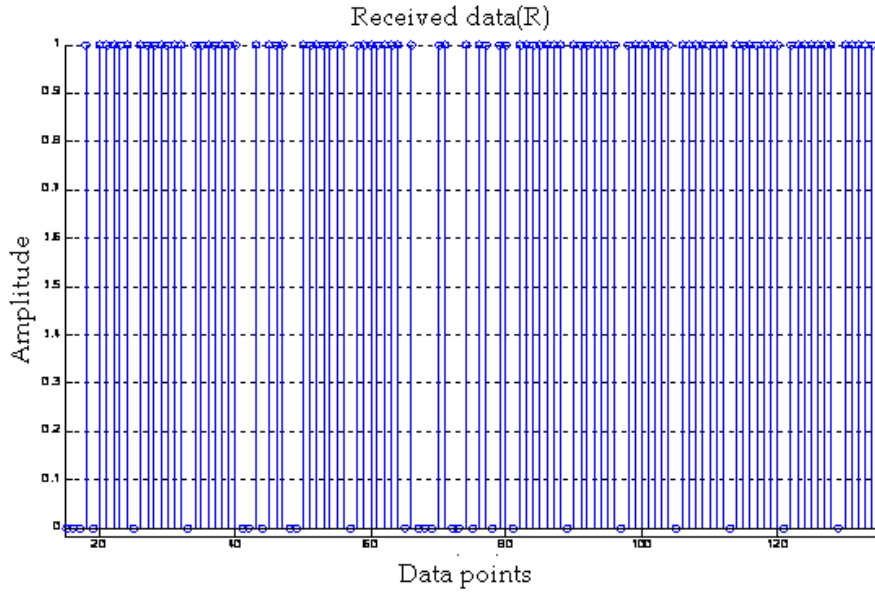

(b)

Figure 6.2 (a) Randomly generated binary signals (b) Received binary signals

The above figure 6.2 refers the two expected signal wave forms; figure 6.2 (a) is given to the OFDM system for BPLC application at transmitter, and figures 6.2(b) the expected outputs at the receiver. The performance is analyzed based on comparison of these pair of wave forms for all of the OFDM systems (QPSK, BPSK, and DPSK). The above input data is divided based on the number of subcarriers for parallel transmission as figure 6.3 below.

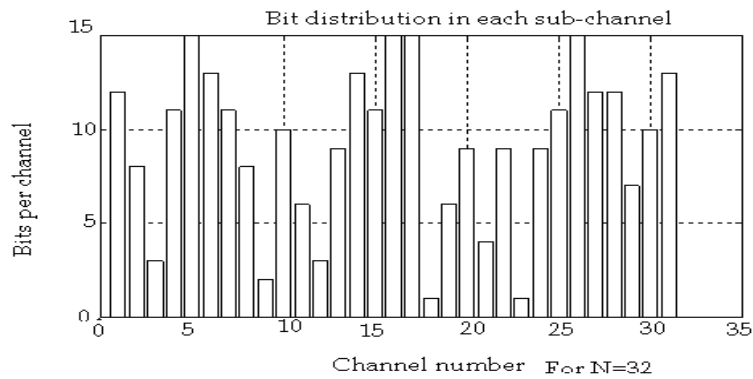

(a)

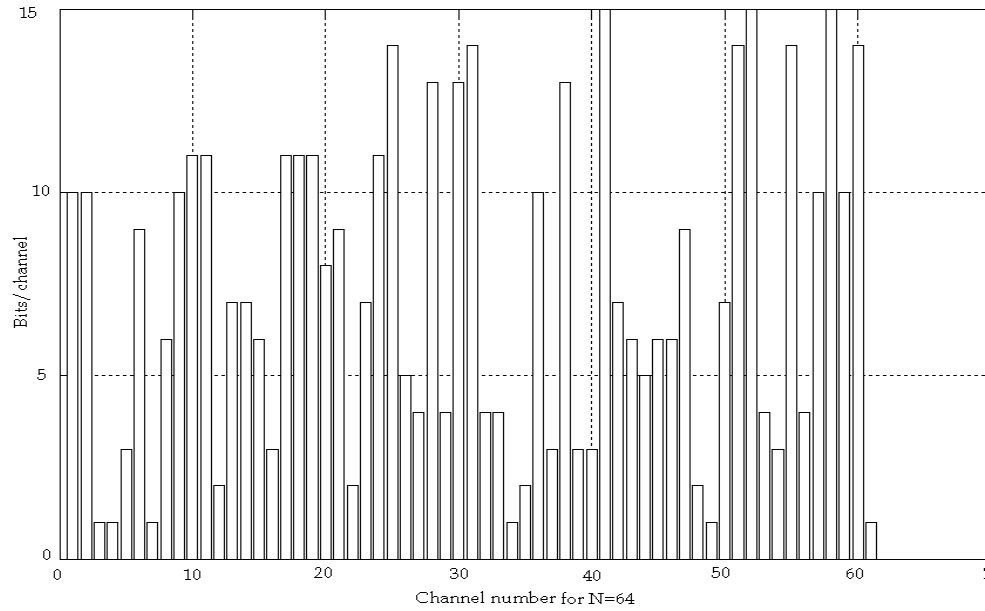

(b)

Figure 6.3 Arrangement of bits in each of the subcarriers

(a) For 32 sub carriers (b) for 64 subcarriers.

Here by changing the number of subcarriers or dividing the length of the data in to different number of subcarriers results the difference in performance due to the interference variations as shown as figure 6.4 below;

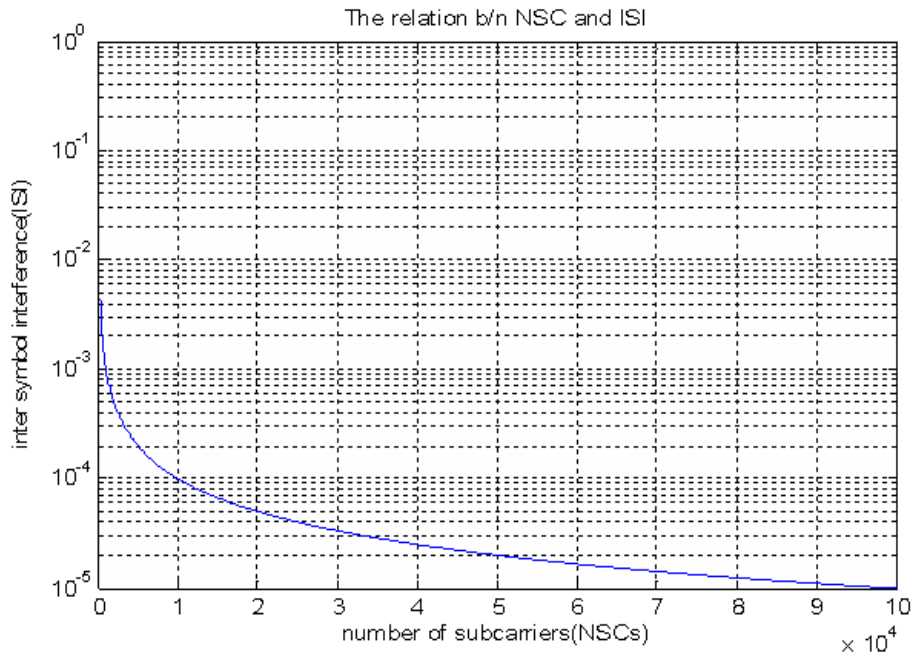
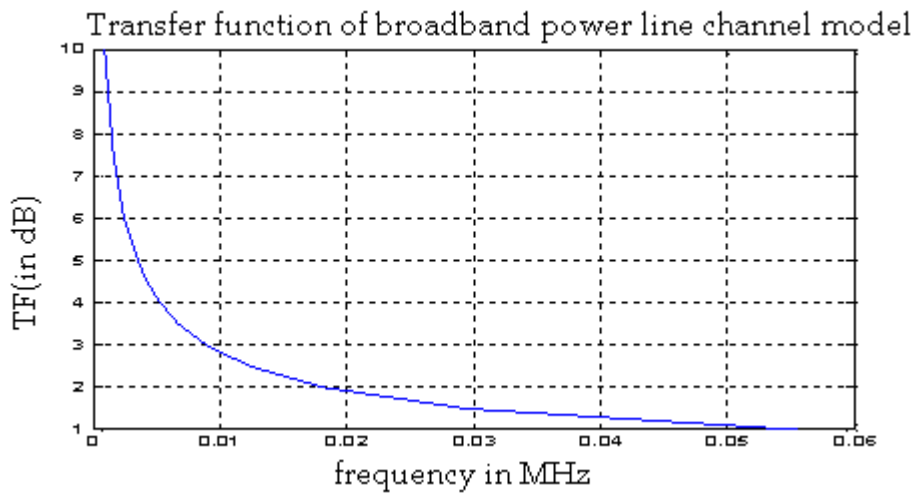

Figure 6.4 dB plot of Intersymbol interference

The figure 6.4 above shows the relation between intersymbol interference and number of sub-carriers, Based on figure 6.4 as the number of subcarriers increases the intersymbol interference decreases. But this increment continues till some reasonable number only. If it is beyond that limit, it may create other difficulties like Doppler shift and the likes.

After the convolution of communication signals and the modeled power line is done, additional filter circuits are used to recover the strength of signal. This indicates even though the power line channel is contaminated by a lot of impurities; it can be compensated even boosted using some additional circuitry.



(a)

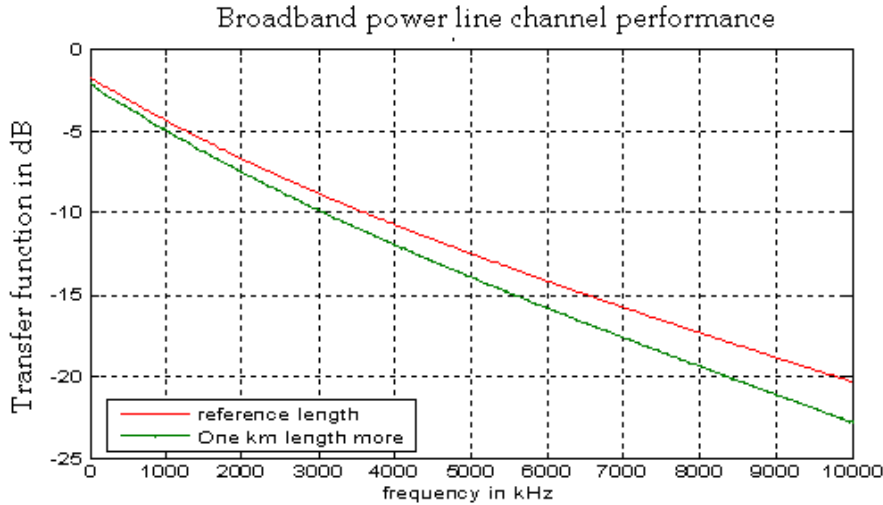

(b)

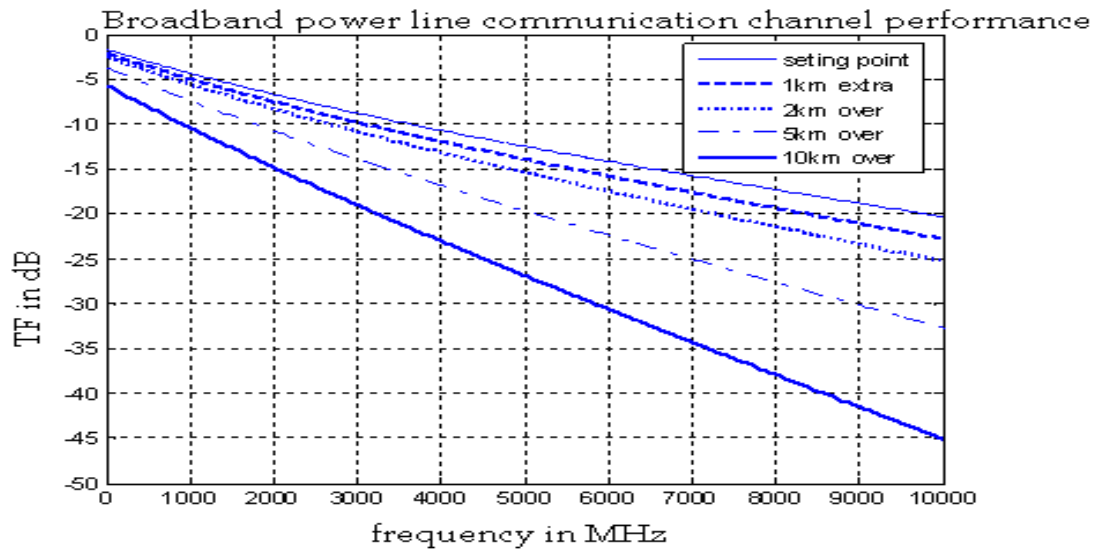

(c)

Figure 6.5 (a) (b) (c) Transfer function broadband power line

From the above figure 6.5 one can infer that the transfer function of the power line channel, as the length of the power line increases the transfer function decreases. Specifically figure 6.5(a) shows the reference length transfer functions and the relationship between the transfer function with the frequency of the supplied voltage. As the frequency increases the transfer function decreases, which means the output of the system become minimized.

Similarly figure 6.5(b) shows dual performances, one the frequency and the transfer function relations, second the comparison based on length, as the length increase, the transfer function of the system decreases. And finally figure 6.5(c) refers to the comparison on different lengths.

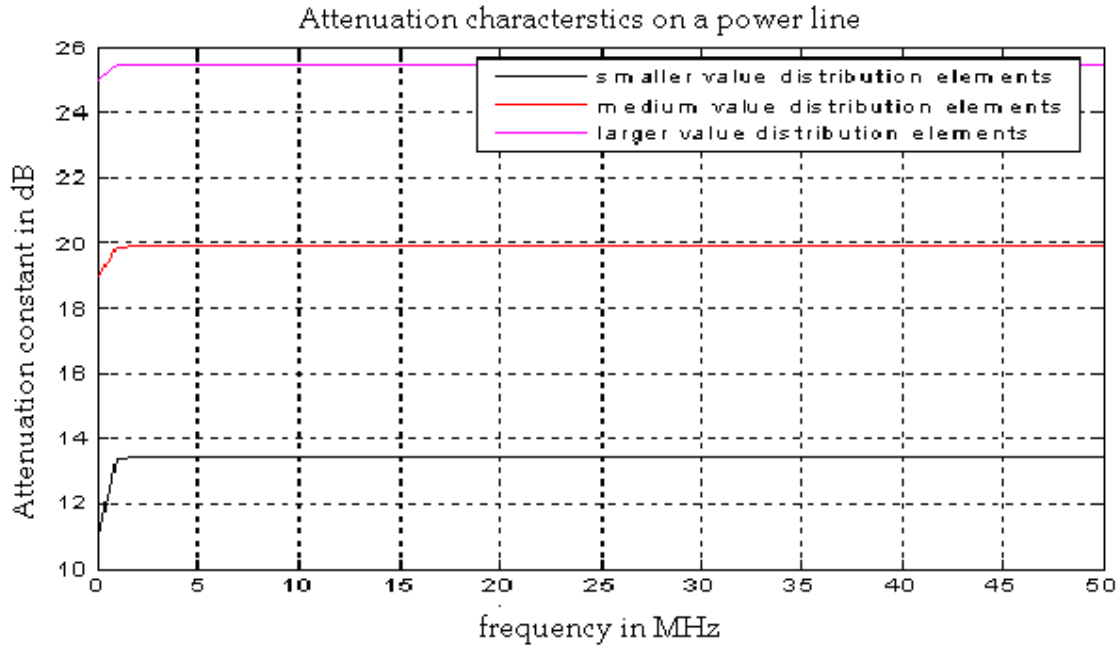

Figure 6.6 attenuation characteristics of broadband power line

From this figure 6.6 above, it can be seen that the attenuation of the broadband power line is directly proportional to the frequency of the supply voltage, this implies as the frequency of the supply increases the attenuation developed in the broadband power line communications increases, which degrades the performance of signal.

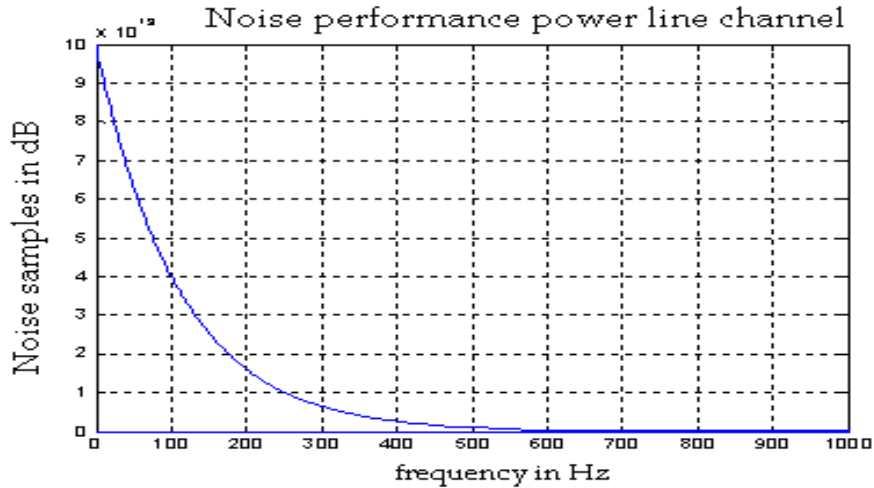
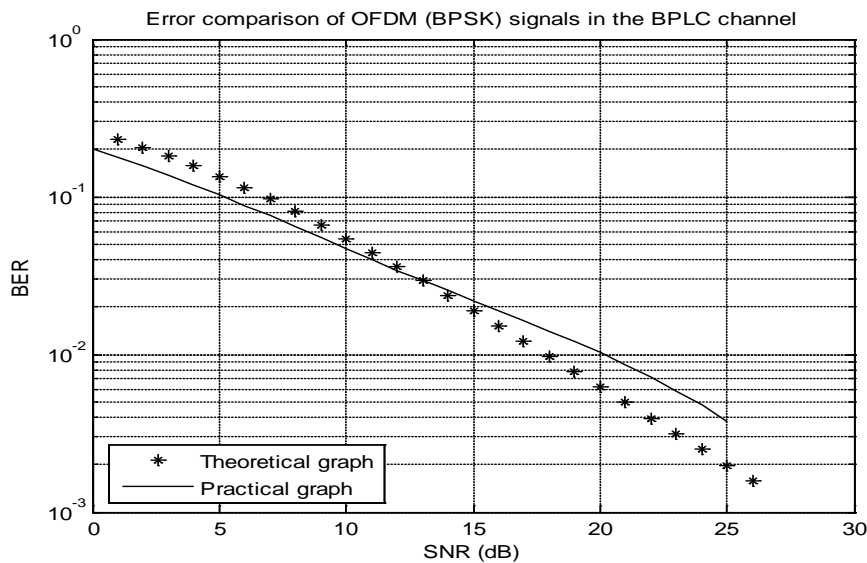
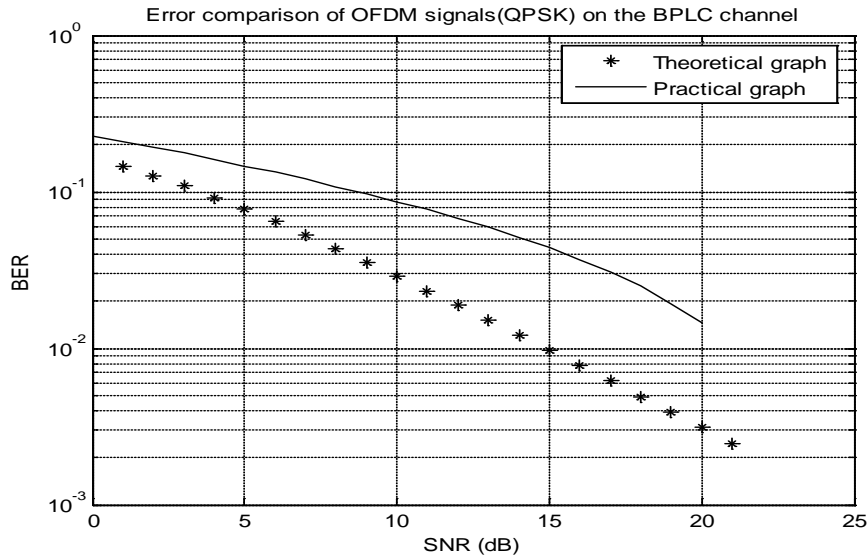

Figure 6.7 Noise performance of broadband power line channel

The above figure 6.7 refers the relation ship between frequency of communication signal and the noise developed in the power line, as the frequency increases the noise developed in the system decreases, which means the noise interference on the broadband power line communication systems become minimized.



(a)



(b)

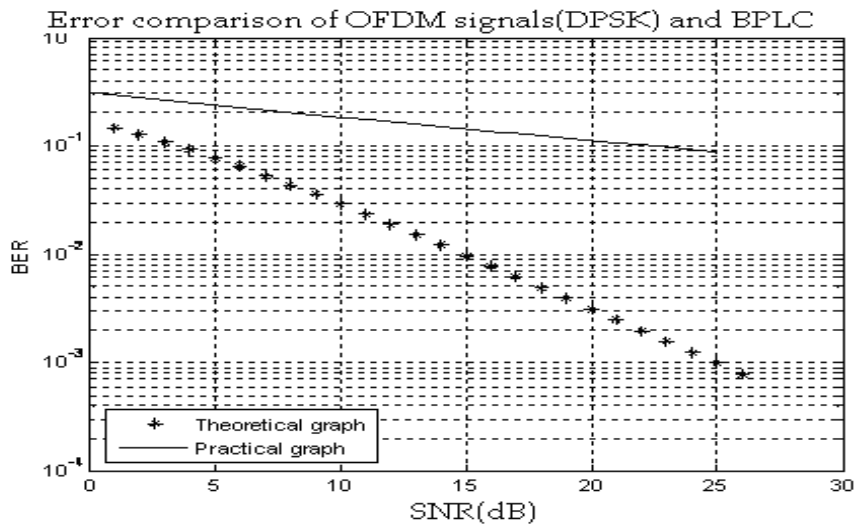

(c)

Figure 6.8 Error performance comparisons of OFDM signals for ideal and power line channel (a) BPSK signals (b) QPSK signals (c) DPSK signals

The figure 6.8 above shows the comparison of practical and theoretical bit error rate of OFDM signals. From figure 6.8(a) the theoretical and practical performance graph of the BPSK signal is shown, and the practical BER graph has a deviation from the theoretical graph. Similarly from figure 6.8(b) the BER performance in the QPSK system and (c) shows BER of DPSK signals. In general, the theoretical and practical graphs are shown,

from this the deviation so worst than the previous BPSK systems, which gives a direction of the BPSK signals are preferable than QPSK signals for broadband power line communication systems.

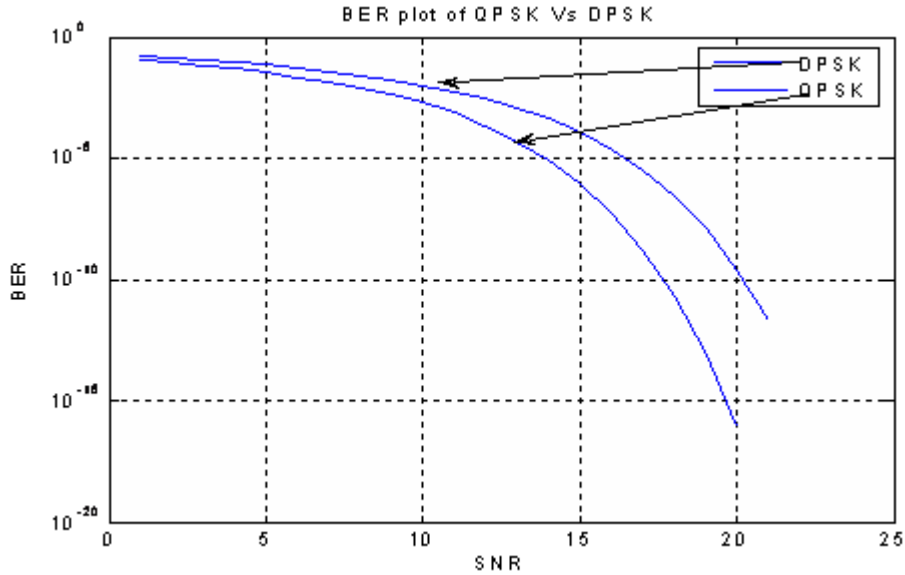

Figure 6.9 Bit error rate comparison of DPSK and QPSK signals in BPLC systems

The above figure 6.9 shows the comparison of the two modulation systems, DPSK and QPSK systems for broadband power line communications. These comparisons are on the bases of their BER performance, the BER of QPSK signals are larger than DPSK. In other words QPSK is preferable than DPSK systems in the area of broadband power line communications.

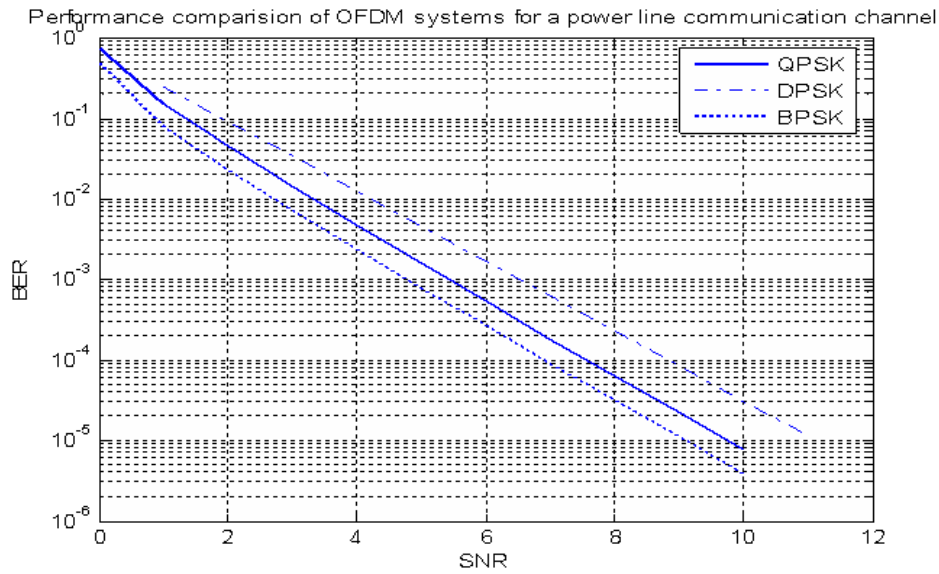

Figure 6.10 Theoretical (ideal channel) BER in dB comparisons of the three OFDM signals

Figure 6.10 above compares the performance of OFDM signals in the ideal channels. One can refer that BPSK signals have a better performance than the other two systems QPSK and DPSK signals and QPSK is the next and finally DPSK is selected for ideal wireless communication systems, it is used as reference.

SNR	DPSK	QPSK	BPSK
1	0.2909	0.2407	0.1586
2	0.2876	0.2395	0.1576
3	0.2844	0.2382	0.1565
4	0.2813	0.2368	0.1553
5	0.2783	0.2352	0.1539
6	0.2753	0.2334	0.1524
7	0.2724	0.2314	0.1507
8	0.2695	0.2292	0.1488

a) N=16

SNR	DPSK	QPSK	BPSK
1	0.2896	0.2177	0.1414
2	0.2859	0.2134	0.1380
3	0.2822	0.2087	0.1343
4	0.2786	0.2034	0.1301
5	0.2749	0.1976	0.1256
6	0.2712	0.1913	0.1207
7	0.2675	0.1844	0.1154
8	0.2637	0.1769	0.1099

b) N=32

SNR	DPSK	QPSK	BPSK
1	0.2687	0.1329	0.1327
2	0.2579	0.1258	0.1276
3	0.2481	0.1187	0.1217
4	0.2393	0.1115	0.1151
5	0.2313	0.1043	0.1078
6	0.2239	0.0972	0.0999
7	0.2170	0.0902	0.0916
8	0.2104	0.0835	0.0830

N=64  
(c)

SNR	DPSK	QPSK	BPSK
1	0.2224	0.0957	0.0450
2	0.2111	0.0897	0.0401
3	0.1995	0.0837	0.0354
4	0.1879	0.0780	0.0308
5	0.1762	0.0725	0.0265
6	0.1649	0.0674	0.0226
7	0.1539	0.0627	0.0206
8	0.1436	0.0585	0.0110

N=128  
(d)

Table 6.11 BER comparison of OFDM systems in BPLC applications using different sub-carriers

As it is referred from the table above the BER is become lowered when the sub-carriers number is maximized. This relation interference verses number of subcarrier is shown in figure 6.4 above.

Lastly due to the results shown above using a power line grid for accessing broadband services is the best and a promising solution, this is when BPSK is applied instead of other OFDM modulation techniques. This results can be shown in the following figure 6.11 below.

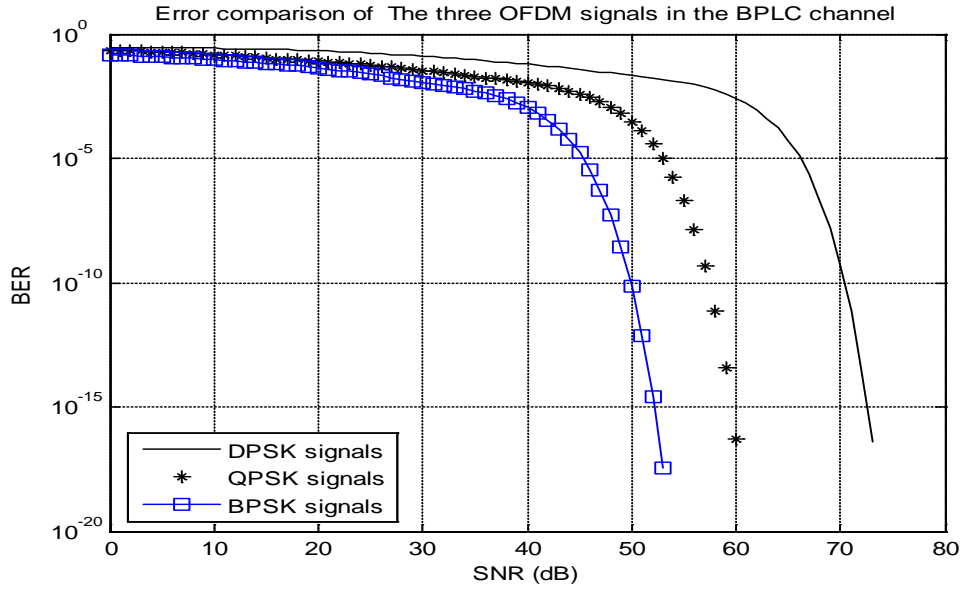

N=16

(a)

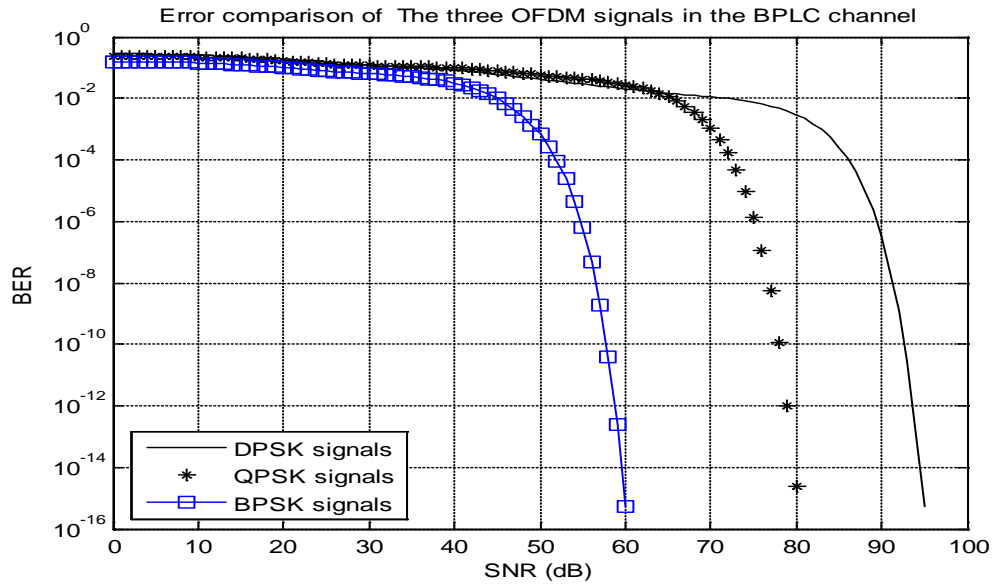

N=32

(b)

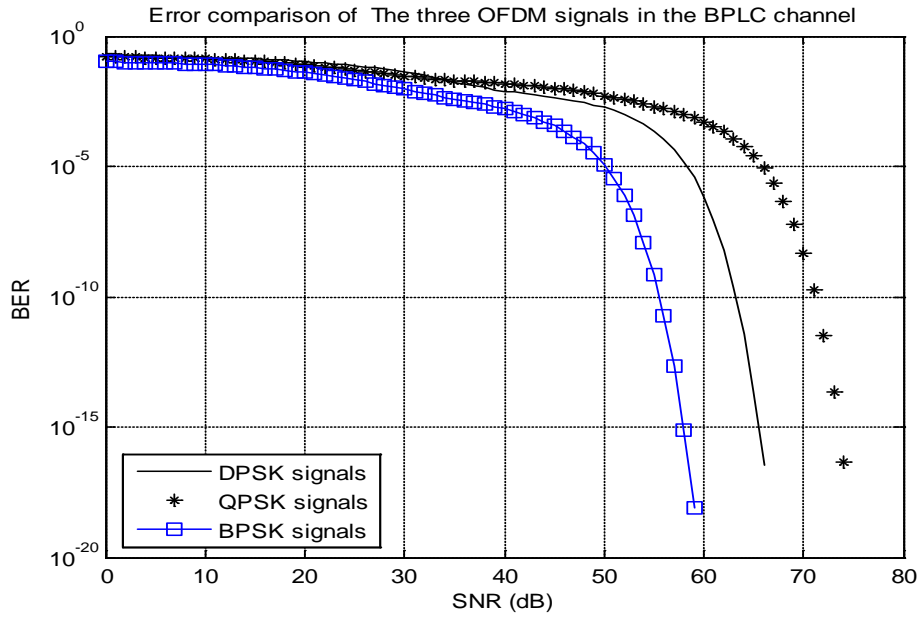

N=64  
(c)

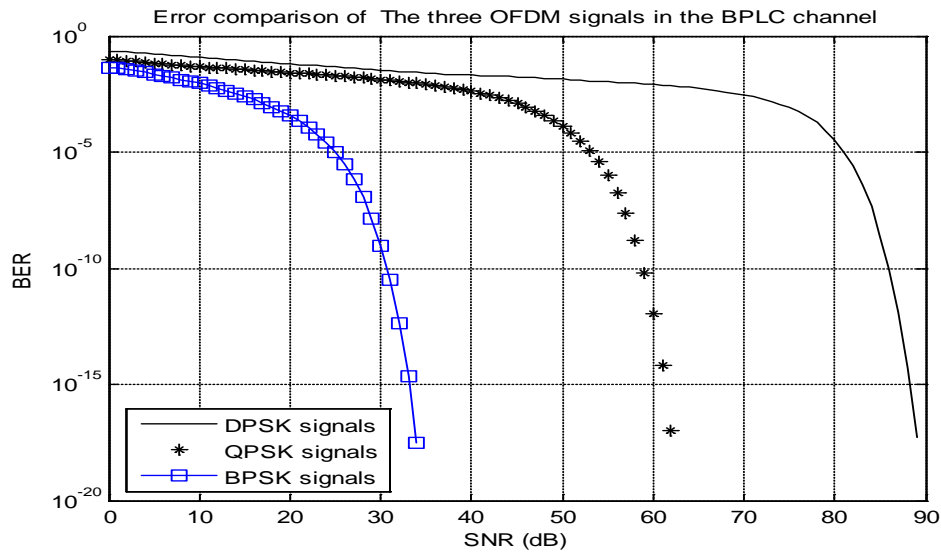

N=128  
(d)

Figure 6.12 Error comparison graphs based on different number of sub-carriers of OFDM signals for BPLC application

From the above figure 6.11 (a) to (d) the error comparison is clearly identified. The graph is the bit error rate versus the signal to noise ratio based on the number of sub-carriers and the type of OFDM system.

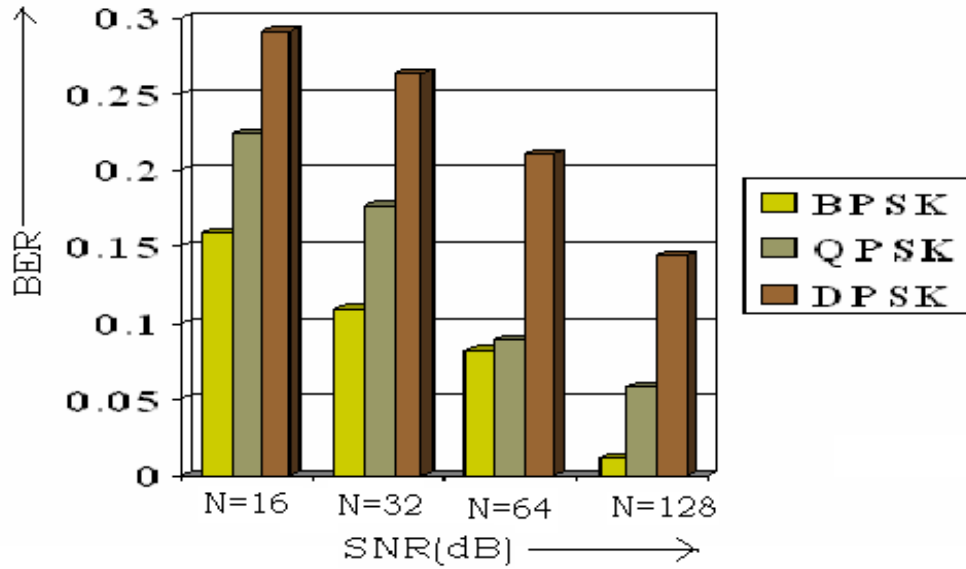

Figure 6.13 BER comparisons of OFDM systems for BPLC applications

## 6.2 Conclusions of the thesis

Accessing broadband services with a minimum error has a great role in the area of communication. The question is how this can be achieved? To answer this question, each possible alternative must be tried out and the selected one is going to be implemented.

From the different techniques that enable to access broadband solutions, broadband power line communication is the one that is accessible for all societies, urban and rural,

since the power line grid is already setup. Other alternatives are in full of obstacles as it is stated in the above chapters.

Broadband power line communications can be conducted using different techniques, from these OFDM based approach is preferable due its advantage.

This thesis, the performance comparison of broadband power line communications using OFDM systems enables to identify the preferable OFDM system for broadband power line communication. It is done by setting different number of subcarriers to the OFDM system as indicated in figure 6.2. From the above thesis results, broadband communication systems is achieved by the convolution of the power line grid to results of OFDM systems like QPSK, BPSK and DPSK, is a better way of communication that can minimize the intersymbol-interferences (ISI) and intercarrier-interferences (ICI) in addition to its cost effectiveness and other relevancies, since the power line infrastructure is already pre-installed (already existed) channel. Based on the signal to noise ratio verses bit error rate simulation results of OFDM signals (BPSK, QPSK, and DPSK). Instead of using a random modulation techniques for broadband power line communications, selecting the promising best method of modulation is preferable because of the results found above which binary phase shift is keying is alternatively selected.

As results from figure 6.11 (a) to (d) found from the matlab simulation, it is indicated that BPSK, QPSK and DPSK signals are compared and BPSK is preferable in performance for broadband power line communication than QPSK and also the performance of QPSK is preferable than DPSK. In other words the BER of the DPSK signal is greater than the other two BER values when the same value of SNR is taken. This can be set in descending order of performance as follows BPSK then QPSK and finally DPSK. In addition to this the results are based on the different number of subcarriers; figure 6.11 shows the comparison when number of subcarriers is 16, 32, 64,128. From these results, it can be concluded that as the number of subcarriers increases the interference faced on the BPLC system is minimized due to reasons mentioned before in this report. A better result can be obtained when large numbers of subcarriers are used.

Lastly, from the above three methods of modulation schemes BPSK is more preferable than QPSK and DPSK systems, and next QPSK is preferable than DPSK. Finally DPSK is selected at last.

### **6.3 Recommendations and further works**

✚ As we have seen in this paper, OFDM enables us to access a better broadband communication through the existing power line grid, but it faces some problems. The better result may be obtained by using WOFDM (Wideband Orthogonal Frequency Division Multiplexing) than OFDM due to the following promising effects,

- Wide frequency band used intentionally
- Robust against multipath fading, which eliminates problems associated with OFDM
- Very good bandwidth efficiency, this means high data rates.
- Potential data rates up to 155 Mbps (and beyond)

### **A simulation code for Performance comparison of Broadband power line communications using OFDM modulation systems**

```
%ofdmchain(bit_rate,time,num_subcarriers,snr,max_doppler,guard_length,est_rate,mpath,eql)
% the ofdm parameters
% bit_rate=the desired bit-rate in bps.
% time = time length in seconds.
% N=num_subcarriers = desired number of sub carriers.
% snr =SNR required in dB,
% guard_length = Guard length in micro seconds.
% function
ber=ofdm(bit_rate,time,num_subcarriers,snr,max_doppler,guard_length,est_rate,mpath,eql)
% 2. Create blocks of data points from the serial stream, in matrix
% form where after IFFT & Cyclic Prefixing (CP), each block
% will become an OFDM block
% 3. Add CP to existing blocks of data
% 4. Convert matrix of blocks of data & CP into an OFDM signal for TX
% Receiver
% 5. On the RX end, add a power line channel via "filter" command
% or using "conv" command. to the transmitted communication signal.
% 6. Remove CP, do FFT & demodulate
% 7. finally plot the error
%td = 58; % Delayspread =in nsec
%B = 45;% AssignedBWin MHz
%Tg = % cp_len=v= 4*td;
%Tos = %OFDMsymbolduration = 8*Tg;
%fd = ; %Subcarrierspacing= 1/Tos
%Ts = 7.2% Totalsymboltime = Tos + Tg;
%N =84; % Numberofsubcarriers =B/fd

M = 4; % QPSK signal constellation
% M2=2;
no_of_data_points = 128; % have 128 data points
block_size = 8; % size of each ofdm block
N=16; % number of subcarriers
cp_len = ceil(0.1*8);
v =cp_len
% length of cyclic prefix
no_of_ifft_points = block_size; % 128 points for the FFT/IFFT
no_of_fft_points = block_size;
snr=0:0.5:5;
```

```
% B: % +++++ TRANSMITTER SIDE +++++
% Generate 1 x 128 vector of random data points
data_source = randint(1, no_of_data_points);
tx=data_source;
figure(1);
stem(data_source); grid on; xlabel('Data Points'); ylabel('Amplitude')
title('Transmitted Data "T"')
fprintf('Press Enter to continue')
pause
clc
% For each of N channels assign no. of bits and generation of the data stream
% such that sum of all (bits/subchannel) = the data length.
%Bit Allocation and data generation %%%%%%%%%%%
N=32;
for i=1:N-1,
    %Since the SNR of each subchannel is unknown, bit loading is random
    bit_channel(i)=ceil(rand*15);
end
    figure(2)
bar(bit_channel,'w');
title('Bit Distribution in each sub-channel');
xlabel('Channel Number');
ylabel('bits/channel');
fprintf('Press Enter to continue')
grid on
pause
clc
% Data assignment in each channel
for i=1:N-1
    data_channel=[];
    % data_channel is the particular data assigned to the subchannel.
    for j=1:bit_channel(i),
        val=round(rand);
        data_channel=[data_channel val];
    end
    % data contains all the data_channel values.
    data{i}=data_channel;
end
clear i j;
% 3. Perform QPSK modulation
qpsk_modulated_data = pskmod(data_source, M); %QPSK modulation
%dpsk_modulated_data = dpskmod(data_source,M); % DPSK modulation
%bpsk_modulated_data = pskmod(data_source,2); % BPSK demodulation
```

```
%scatterplot(qpsk_modulated_data);title('QPSK Modulation')
%scatterplot(dpsk_modulated_data);title('DPSK Modulation')
%scatterplot(bpsk_modulated_data);title('BPSK Modulation')
fprintf('Press Enter to continue')
grid on
pause
clc
% Do IFFT on each block
% Make the serial stream a matrix where each column represents a pre-OFDM
% block (w/o cyclic prefixing)
% First: Find out the number of columns that will exist after reshaping
num_cols=length(qpsk_modulated_data)/block_size;
%num_cols=length(dpsk_modulated_data)/block_size;
%num_cols=length(bpsk_modulated_data)/block_size;
% serial to parallel conversion
parallel_data_matrix = reshape(qpsk_modulated_data, block_size, num_cols);
%parallel_data_matrix = reshape(dpsk_modulated_data, block_size, num_cols);
%parallel_data_matrix = reshape(bpsk_modulated_data, block_size, num_cols);
% Second: Create empty matrix to put the IFFT'd data
cp_start = block_size-cp_len;
cp_end = block_size;
% Third: Operate columnwise & do CP
for i=1:num_cols,
    ifft_data_matrix(:,i) = ifft((parallel_data_matrix(:,i)),no_of_ifft_points);
    % Compute and append Cyclic Prefix
    for j=1:cp_len,
        actual_cp(j,i) = ifft_data_matrix(j+cp_start,i);
    end
    % Append the CP to the existing block to create the actual OFDM block
    ifft_data(:,i) = vertcat(actual_cp(:,i),ifft_data_matrix(:,i));
end
% 5. Convert to serial stream for transmission
[rows_ifft_data cols_ifft_data]=size(ifft_data);
len_ofdm_data = rows_ifft_data*cols_ifft_data;
% Actual OFDM signal to be transmitted
ofdm_signal = reshape(ifft_data, 1, len_ofdm_data);
figure(3)
plot(abs(ofdm_signal)); xlabel('Time'); ylabel('Amplitude');
title('OFDM Signal');grid on;
fprintf('Press Enter to continue')
pause
clc
% C: % +++++ CHANNEL +++++
```

```
%1. *****The power line channel model transfer function*****
% Broadband power line communications channel using OFDM systems.
%the matlab program used to plot the magnitude of the channel transfer function
f=[0:1000:45000000];
% the possible frequency ranges
g=[.54,.275,-0.15,0.08,-0.03,-0.02];
d=[200,221,242,259,266,530];
%distances of each path.
k=1;
% constants of the attenuation parameter
N=6;% number of paths.
a0=-2.1*10^-3;
% suitably selected attenuation parameters for a power line communication channel.
a1=8.1*10^-10;
%% suitably selected attenuation parameters for a power line.
vp=3*10^8;
for j=1:length(f);
    sum=0;
    for i=1:N;
        sum=sum+g(i)*exp(-(a0+a1*f(j)^k)*d(i))*exp(complex(-2*pi*f(j)*d(i)*1/vp));
    end;
    H(j)=sum;
end;
figure(1);
plot(f,(10*log(H)))
xlabel('frequency in kHz');ylabel('transfer function in dB')
title('channel performance')
grid on
fprintf('Press Enter to continue')
pause
clear
close
clc
% _____power line communication channel model when each path length is 1km
more.
f=[0:25:10000];
% the possible frequency ranges
g=[-0.09,0.74,-0.088,-0.0997,0.095,0.99];
%the weighting factor representing the
% product of the reflection and transmission factors along the path.
d=[25000,7000,18000,13500,14000,25000];
%distances of each paths.
k=1;
```

```
% constants of the attenuation parameter
N=6;
a0=4.5*10^-5.05;
% suitably selected attenuation parameters for a power line.
a1=-2*10^-10;
%% suitably selected attenuation parameters for a power line.
vp=3*10^8;
for j=1:length(f);
    sum=0;
    for i=1:N;
        sum=sum+g(i)*exp(-(a0+a1*f(j)^k)*d(i))*exp(complex(-2*pi*f(j)*d(i)*1/vp));
    end;
    H(j)=sum;
end;
figure(2);
plot(f,(10*log(H)))
xlabel('frequency in kHz');ylabel('transfer function in dB')
title('channel performance')
grid on
hold on
% the matlab program used to plot the magnitude of the the transfer function
% of the power line communication channel model when each path length is 1km more.
f=[0:25:10000];
% the possible frequency ranges
g=[-0.09,0.74,-0.088,-0.0997,0.095,0.99];
% the weighting factor representing the
% product of the reflection and transmission factors along the path.
d=[26000,8000,19000,14500,15000,26000];
% distances of each paths.
k=1;
% constants of the attenuation parameter
N=6;
a0=4.5*10^-5.05;
% suitably selected attenuation parameters for a power line.
a1=-2*10^-10;
%% suitably selected attenuation parameters for a power line.
vp=3*10^8;
for j=1:length(f);
    sum=0;
    for i=1:N;
        sum=sum+g(i)*exp(-(a0+a1*f(j)^k)*d(i))*exp(complex(-2*pi*f(j)*d(i)*1/vp));
    end;
    H(j)=sum;
```

```
end;
plot(f,(10*log(H)))
xlabel('frequency in kHz');ylabel('transfer function in dB')
title('channel performance')
grid on
hold on
%channel model when each path length is 2km more.
g=[-0.09,0.74,-0.088,-0.0997,0.095,0.99];
d=[27000,9000,20000,15500,16000,27000];
for j=1:length(f);
    sum=0;
    for i=1:N;
        sum=sum+g(i)*exp(-(a0+a1*f(j)^k)*d(i))*exp(complex(-2*pi*f(j)*d(i)*1/vp));
    end;
    H(j)=sum;
end;
plot(f,(10*log(H)))
xlabel('frequency in kHz');ylabel('transfer function in dB')
title('channel performance')
grid on
hold on
% channel model when each path length is five km more.
g=[-0.09,0.74,-0.088,-0.0997,0.095,0.99];
d=[30000,12000,23000,18500,19000,30000];%the weighting factor representing the
for j=1:length(f);
    sum=0;
    for i=1:N;
        sum=sum+g(i)*exp(-(a0+a1*f(j)^k)*d(i))*exp(complex(-2*pi*f(j)*d(i)*1/vp));
    end;
    H(j)=sum;
end;
plot(f,(10*log(H)))
xlabel('frequency in kHz');ylabel('transfer function in dB')
title('channel performance')
grid on
hold on
%the matlab program used to plot the magnitude of the the transfer function
%of the power line communication channel model when the path is nine.
f=[0:25:10000];
% the possible frequency ranges
g=[-0.09,0.74,-0.088,-0.0997,0.095,0.99,0.095,0.095,0.095];
%the weighting factor representing the
% product of the reflection and transmission factors along the path.
```

```
d=[25000,7000,18000,13500,14000,25000,30000,30000,30000];
%distances of each paths.
k=1;
% constants of the attenuation parameter
N=9;
a0=4.5*10^-5.05;
% suitably selected attenuation parameters for a power line.
a1=-2*10^-10;
%% suitably selected attenuation parameters for a power line.
vp=3*10^8;
for j=1:length(f);
    sum=0;
    for i=1:N;
        sum=sum+g(i)*exp(-(a0+a1*f(j)^k)*d(i))*exp(complex(-2*pi*f(j)*d(i)*1/vp));
    end;
    H(j)=sum;
end;
plot(f,(10*log(H)))
xlabel('frequency in kHz');ylabel('transfer function in dB')
title('channel performance')
grid on
hold on
% -----channel model when each path length is ten kms more.
g=[-0.09,0.74,-0.088,-0.0997,0.095,0.99];
d=[35000,17000,28000,23500,24000,35000];
for j=1:length(f);
    sum=0;
    for i=1:N;
        sum=sum+g(i)*exp(-(a0+a1*f(j)^k)*d(i))*exp(complex(-2*pi*f(j)*d(i)*1/vp));
    end;
    H(j)=sum;
end;
plot(f,(10*log(H)))
xlabel('frequency in kHz');ylabel('transfer function in dB')
title('channel performance')
grid on
hold on
%channel model when the path is twelve.
g=[-0.09,0.74,-0.088,-0.0997,0.095,0.99,0.095,0.095,0.095,0.095,0.095,0.095];
d=[25000,7000,18000,13500,14000,25000,30000,30000,30000,30000,30000,30000];
N=12;
for j=1:length(f);
    sum=0;
```

```
    for i=1:N;
        sum=sum+g(i)*exp(-(a0+a1*f(j)^k)*d(i))*exp(complex(-2*pi*f(j)*d(i)*1/vp));
    end;
    H(j)=sum; % channel transfer function.
end;
plot(f,(10*log(H)))
xlabel('frequency in kHz');ylabel('transfer function in dB')
title('channel performance')
grid on
fprintf('Press Enter to continue')
pause
clc
% 2. Pass the ofdm signal through the channel
after_channel = filter(channel, 1, ofdm_signal);
%after_channel=conv(ofdm_signal,channel);
figure(5)
plot(after_channel)
xlabel('time');ylabel('Amplitude')
title('After channel output')
grid on
fprintf('Press Enter to continue')
pause
clc
% ++++++ RECEIVER TAIL END ++++++
% Add Noise for calulating BER
awgn_noise = awgn(zeros(1,length(after_channel)),0);
noise_power = abs(awgn_noise);
recvd_signal = after_channel;          % Without noise
%recvd_signal = awgn_noise+after_channel; % With AWGN noise
% 4. Convert Data back to "parallel" form to perform FFT
recvd_signal_matrix = reshape(recvd_signal,rows_ifft_data, cols_ifft_data);
% 5. Remove CP
recvd_signal_matrix(1:cp_len,:)=[];
% 6. Perform FFT
for i=1:cols_ifft_data,
    % FFT
    fft_data_matrix(:,i) = fft(recvd_signal_matrix(:,i),no_of_fft_points);
end
% 7. Convert to serial stream

recvd_serial_data = reshape(fft_data_matrix, 1,(block_size*num_cols));
% Demodulate the data
qpsk_demodulated_data = qpskdemod(recvd_serial_data,M); %Qpsk demodulation
```

```
figure(6);
stem(qpsk_demodulated_data,'rx');
hold on
dpsk_demodulated_data = dpskdemod(recvd_serial_data,M); %dpsk demodulation
figure(7);
stem(dpsk_demodulated_data,'rx');
hold on
bpsk_demodulated_data = pskdemod(recvd_serial_data,2); % BPSK demodulation
figure(8);
stem(bpsk_demodulated_data,'rx');
grid on;
xlabel('Data Points');
ylabel('Amplitude');
title('Received Data "R"')
fprintf('Press Enter to continue')
pause
clc
Nsamp = 16;
num = ones(Nsamp,1)/Nsamp;
den = 1;
EbNo = [0:20]; % Range of Eb/No values under study
ber1=semianalytic(qpsk_modulated_data,recvd_serial_data,'dpsk',M,Nsamp,num,den,
EbNo);
%ber2 =
semianalytic(dpsk_modulated_data,recvd_serial_data,'psk',M,Nsamp,num,den,EbNo);
%ber3 =
semianalytic(bpsk_modulated_data,recvd_serial_data,'psk',2,Nsamp,num,den,EbNo);
% Plot computed BER and theoretical BER.
% For comparison, calculate theoretical BER.
bertheory1 = berfading(EbNo,'dpsk',M,1);
bertheory2 = berfading(EbNo,'psk',M,1);
bertheory3 = berfading(EbNo,'psk',16,1);
figure(9);
semilogy(bertheory1)
hold on
semilogy(bertheory2)
hold on
semilogy(bertheory3)
hold off
figure(10);
semilogy(EbNo,ber1,'k-');
hold on
%semilogy(EbNo,ber2,'k-');
```

```
hold on
%semilogy(EbNo,ber3,'k-');
grid on
title('practical BER Compared with Theoretical BER');
legend('practical BER',...
       'Theoretical BER','Location','SouthWest');
xlabel('SNR (dB)');
ylabel('BER');
title('Binary DPSK over power line Channel');
hold off
clc

%-----END-----
```