



**ADDIS ABABA UNIVERSITY**  
**ADDIS ABABA INSTITUTE OF TECHNOLOGY**  
**SCHOOL OF GRADUATE STUDIES**  
**DEPARTMENT OF ELECTRICAL AND COMPUTER ENGINEERING**

**Design and Simulation of a Wireless Based Transcutaneous Electrical Nerve  
Stimulator for Pain Control**

**By**  
**Ashenafi Paulos**

**Advisor**  
**Dr. Eng. Getachew Alemu**

**A Thesis Submitted to the School of Graduate Studies of Addis Ababa University in  
Partial Fulfillment of the Requirements for the Degree of Master of Science in  
Microelectronics Engineering.**

**October - 2016**  
**Addis Ababa, Ethiopia**

**ADDIS ABABA UNIVERSITY  
ADDIS ABABA INSTITUTE OF TECHNOLOGY  
SCHOOL OF GRADUATE STUDIES  
DEPARTMENT OF ELECTRICAL AND COMPUTER ENGINEERING**

**Design and Simulation of a Wireless Based Transcutaneous Electrical Nerve  
Stimulator for Pain Control**

**By  
Ashenafi Paulos**

**Advisor  
Dr. Eng. Getachew Alemu**

**October - 2016  
Addis Ababa, Ethiopia**

**ADDIS ABABA UNIVERSITY**  
**ADDIS ABABA INSTITUTE OF TECHNOLOGY**  
**SCHOOL OF GRADUATE STUDIES**  
**DEPARTMENT OF ELECTRICAL AND COMPUTER ENGINEERING**

**Design and Simulation of a Wireless Based Transcutaneous Electrical Nerve  
Stimulator for Pain Control**

**By**  
**Ashenafi Paulos**

**BOARD OF EXAMINERS**

----- Chairman (department of graduate committee)	----- Signature
----- Advisor	----- Signature
----- Internal Examiner	----- Signature
----- External Examiner	----- Signature

## **Declaration**

I, the undersigned, declare that this thesis is my original work, has not been presented for degree in any other university and that all sources of materials used for the thesis have been duly acknowledged.

Ashenafi Paulos

Name

\_\_\_\_\_

Signature

Addis Ababa, Ethiopia

Place

October, 2016

Date of Submission

This thesis has been submitted for examination with my approval as a university advisor.

Dr. Eng. Getachew Alemu

Advisor Name

\_\_\_\_\_

Signature

## **Acknowledgement**

First of all, my most sincere thanks goes' out to my advisor, Dr. Eng. Getachew Alemu, for his guidance and support. His passion towards his work and dedication to his students is truly remarkable.

I would also like to express my gratitude to all Addis Ababa Institute of Technology (AAiT), Electrical and Computer Engineering Department and Microelectronics Engineering Stream staffs for their support and for making this work possible.

Finally, I would like to thank my family, particularly my parents for making this possible with their encouragement and support.

## **Abstract**

Pain is general term for unpleasant sensory and emotional experience associated with actual or potential tissue damage. For this reason, pain control and management is an important welfare concern even in routine management procedures of patients. The most widely used controls for pain at the present time are narcotic treatments. Recently, electrical nerve stimulation has emerged as a new mechanism for pain control that replace the narcotics which is a mechanism of injecting electrical impulse to the surface of the human body that suppressed the pain, but almost all developed systems are wired based and are not user friendly. Whereas, the narcotics most commonly prescribed have not only had a number of worrisome side effects, but also the cost is high and not affordable by most of the patients specifically in developing countries.

In this thesis a wireless programmable microcontroller based transcutaneous electrical nerve stimulator has been designed and simulated, and the designed system gives a chance to the user to choose from the different types of stimulation parameters, like amplitude, frequency, pulse width, and duration, for how long the stimulation should be maintained. To achieve the specific advantages, the designed system uses eight levels of frequency, six levels of pulse-width, and four selectable stages which has been tested on ISIS PROTEUS DESIGN SUIT software, and for the programming parts of the design, mikro C PRO software for PIC language which is a popular high-level C programming language and Arduino Programming Language Software which is a simplified version of C/C++ has been accustomed. In summary, the proposed system gives different conditions of operations for the subject body to control the pain and overcome the drawbacks of the narcotics. It is flexible and user-friendly compared to the already built transcutaneous electrical nerve stimulation (TENS) systems that are available on related literatures and market.

**Keywords** - Pain, Pain control and management, Wireless microcontroller based stimulation, Electrical nerve stimulation, and Transcutaneous electrical nerve stimulation (TENS) system.

## Table of Contents

Declaration .....	i
Acknowledgement .....	ii
Abstract .....	iii
List of Figures .....	vii
List of Tables .....	x
List of Acronyms .....	xi
List of Symbols .....	xiv
<b>1. INTRODUCTION .....</b>	<b>1</b>
1.1 Overview .....	1
1.2 Problem Statement .....	2
1.3 Research Methodology .....	2
1.4 Research Objectives .....	3
1.4.1 Main Objective .....	3
1.4.2 Specific Objectives .....	3
1.5 Research Scope .....	4
1.6 Related Works .....	4
1.7 Summary .....	6
1.8 Thesis Overview .....	7
<b>2. THEORETICAL AND PRACTICAL BACKGROUND .....</b>	<b>8</b>
2.1 The Nervous System .....	8
2.1.1 Overview of the Entire Nervous System .....	9
2.2 Pain .....	15
2.2.1 The Pain Pathway and Pathophysiologic Mechanisms of Pain .....	15
2.2.1.1 Primary Afferent Fibres [14-16] .....	17
2.2.1.2 Dorsal Horn of the Spinal Cord [14-16] .....	17

2.2.1.3 Ascending Tracts in the Spinal Cord [14-16] .....	17
2.2.1.4 Inhibition of P Pain Transmission [11, 15].....	18
2.2.1.4.1 Gate Control Theory of Pain [14, 15] .....	18
2.2.1.4.2 Descending Inhibition Modulation [11, 15].....	19
2.2.1.4.3 Neuropathic pain [12, 13] .....	19
2.2.2 The Pain Cycle [17].....	20
2.2.2. 1 Breaking the Cycle.....	21
2.3 TENS, A New Modal Quality for Pain Modulation .....	22
2.3.1 Overview of TENS .....	22
2.3.2 A Brief History of Medical Electricity .....	23
2.3.3 Pain and TENS .....	23
2.3.4 Stimulation Parameters.....	24
2.3.4.1 Current .....	24
2.3.4.2 Waveform .....	24
2.3.4.3 Frequency.....	25
2.3.4.4 Pulse Duration/Width.....	25
2.3.4.4 Intensity/Amplitude .....	25
2.3.5 TENS Modes .....	26
2.3.5.1 Conventional TENS .....	26
2.3.5.2 Acupuncture-like TENS (AL-TENS) .....	27
2.3.5.3 Intense TENS .....	28
2.3.6 Possible Mechanism Actions of TENS .....	31
2.3.6.1 Peripheral Mechanisms [31] .....	32
2.3.6.2 Segmental Mechanisms [31].....	32
2.3.6.3 Extrasegmental Mechanisms [31].....	33
2.3.7 Clinical Efficacy .....	34

3. SYSTEM DESIGN AND IMPLEMENTATION .....	36
3.1 Architecture .....	36
3.2 The Designed and Simulated Proposed System .....	36
3.2.1 Overview .....	36
3.2.2 Hardware System Design Stage .....	37
3.2.2.1 The Circuit Diagram of the Designed and Simulated TENS System .....	40
3.2.2.2 The Designed and Simulated Remote Control Unit .....	42
3.2.2.3 The Designed and Simulated Electrical Stimulation Generator Unit .....	43
3.2.3 Software Design Stage.....	45
4. RESULTS AND DISCUSSION .....	48
4.1 Results.....	48
4.1.1 Simulation Results .....	49
4.1.2 Validation of the Simulation Results.....	54
4.2 Discussions .....	64
5. CONCLUSION AND RECOMMENDATION .....	66
5.1 Conclusion .....	66
5.2 Recommendations.....	66
APPENDIX 1: Design Schematics .....	68
APPENDIX 2: Main and Sub Microcontroller, and Communication Modules Details Used by the Thesis.....	69
APPENDIX 3: The Designed and Simulated Wireless Based TENS Device for Pain Control Program Codes for PIC16F887 Controller.....	82
APPENDIX 4: Wireless Communication Unit Program Codes for Receiver (ATmega2560) and Transmitter (ATmega328) Parts.....	87
REFERENCES .....	89

## List of Figures

Figure 1.1: Flow Chart for the Overall Research.....	3
Figure 2.1: The human body and central and peripheral nervous systems.([8]).....	8
Figure 2.2: Diagram of a neuron. ([9]) .....	10
Figure 3.1: Circuit Diagram of The Proposed TENS Device .....	40
Figure 3.2: Schematic for the transmitter side .....	42
Figure 3.3: Schematic from the transmitter to receiver side .....	43
Figure 3.4: Schematic for the Main PIC16F887 Microcontroller.....	44
Figure 4.1: Schematic for the transmitter and receiver parts of the designed and simulated system .....	50
Figure 4.2: The simulation output when the subject making OFF the keypad switch button .....	51
Figure 4.3: The simulation output when the subject making ON the keypad switch button.....	51
Figure 4.4: The main controller part with the start up display before it start the stimulation .....	52
Figure 4.5: The screenshots of frequencies, pulse widths, stage for a single case that can be selected by the subject .....	52
Figure 4.6: The screenshots of the amplitudes ranges from 1V to 35V (shows the minimum and maximum voltage of the system).....	53
Figure 4.7: The overall schematics of designed and proposed system with a stack underflow problem for the full programming code.....	53
Figure 4.8: Frequency (Hz) Comparisons for <i>the Designed_Stimulator_System</i> in Opposition to <i>Research_1[4]</i> for <i>Conventional TENS</i> .....	55
Figure 4.9: Pulse_Width ( $\mu$ s) Comparisons for <i>the Designed_Stimulator_System</i> in Opposition to <i>Research_1[4]</i> for <i>Conventional TENS</i> .....	55
Figure 4.10: Frequency (Hz) Comparisons for <i>the Designed_Stimulator_System</i> in Opposition to <i>Research_1[4]</i> for <i>Acupuncture TENS</i> .....	55
Figure 4.11: Pulse_Width ( $\mu$ s) Comparisons for <i>the Designed_Stimulator_System</i> in Opposition to <i>Research_1[4]</i> for <i>Acupuncture TENS</i> .....	56

Figure 4.12: Frequency (Hz) Comparisons for <i>the Designed_Stimulator_System</i> in Opposition to <i>Research_1[4]</i> for <i>Intense TENS</i> .....	56
Figure 4.13: Pulse_Width ( $\mu$ s) Comparisons for <i>the Designed_Stimulator_System</i> in Opposition to <i>Research_1[4]</i> for <i>Intense TENS</i> .....	56
Figure 4.14: Frequency (Hz) Comparisons for <i>the Designed_Stimulator_System</i> in Opposition to <i>Research_2[5]</i> for <i>Conventional TENS</i> .....	57
Figure 4.15: Pulse_Width ( $\mu$ s) Comparisons for <i>the Designed_Stimulator_System</i> in Opposition to <i>Research_2[5]</i> for <i>Conventional TENS</i> .....	57
Figure 4.16: Frequency (Hz) Comparisons for <i>the Designed_Stimulator_System</i> in Opposition to <i>Research_2[5]</i> for <i>Acupuncture TENS</i> .....	57
Figure 4.17: Pulse_Width ( $\mu$ s) Comparisons for <i>the Designed_Stimulator_System</i> in Opposition to <i>Research_2[5]</i> for <i>Acupuncture TENS</i> .....	58
Figure 4.18: Frequency (Hz) Comparisons for <i>the Designed_Stimulator_System</i> in Opposition to <i>Research_2[5]</i> for <i>Intense TENS</i> .....	58
Figure 4.19: Pulse_Width ( $\mu$ s) Comparisons for <i>the Designed_Stimulator_System</i> in Opposition to <i>Research_2[5]</i> for <i>Intense TENS</i> .....	58
Figure 4.20: Frequency (Hz) Comparisons for <i>the Designed_Stimulator_System</i> in Opposition to <i>Research_3[6]</i> for <i>Conventional TENS</i> .....	59
Figure 4.21: Pulse_Width ( $\mu$ s) Comparisons for <i>the Designed_Stimulator_System</i> in Opposition to <i>Research_3[6]</i> for <i>Conventional TENS</i> .....	59
Figure 4.22: Frequency (Hz) Comparisons for <i>the Designed_Stimulator_System</i> in Opposition to <i>Research_3[6]</i> for <i>Acupuncture TENS</i> .....	59
Figure 4.23: Pulse_Width ( $\mu$ s) Comparisons for <i>the Designed_Stimulator_System</i> in Opposition to <i>Research_3[6]</i> for <i>Acupuncture TENS</i> .....	60
Figure 4.24: Frequency (Hz) Comparisons for <i>the Designed_Stimulator_System</i> in Opposition to <i>Research_3[6]</i> for <i>Intense TENS</i> .....	60
Figure 4.25: Pulse_Width ( $\mu$ s) Comparisons for <i>the Designed_Stimulator_System</i> in Opposition to <i>Research_3[6]</i> for <i>Intense TENS</i> .....	60
Figure 4.26: Frequency (Hz) Comparisons for <i>the Designed_Stimulator_System</i> in Opposition to <i>Research_4[7]</i> for <i>Conventional TENS</i> .....	61
Figure 4.27: Pulse_Width ( $\mu$ s) Comparisons for <i>the Designed_Stimulator_System</i> in Opposition to <i>Research_4[7]</i> for <i>Conventional TENS</i> .....	61

Figure 4.28: Frequency (Hz) Comparisons for *the Designed\_Stimulator\_System* in Opposition to *Research\_4[7]* for *Acupuncture TENS* ..... 61

Figure 4.29: Pulse\_Width ( $\mu$ s) Comparisons for *the Designed\_Stimulator\_System* in Opposition to *Research\_4[7]* for *Acupuncture TENS* ..... 62

Figure 4.30: Frequency (Hz) Comparisons for *the Designed\_Stimulator\_System* in Opposition to *Research\_4[7]* for *Acupuncture TENS* ..... 62

Figure 4.31: Pulse\_Width ( $\mu$ s) Comparisons for *the Designed\_Stimulator\_System* in Opposition to *Research\_4[7]* for *Intense TENS* ..... 62

## List of Tables

Table 2.1: Nerve fiber types in mammalian nerve (adopted from: [10]).....	11
Table 2.2: Numerical classification of sensory neurons (adopted from: [10]).....	12
Table 2.3: Useful definitions (Adopted from [12]).....	20
Table 2.4 TENS techniques that can be achieved using a standard TENS device (Modified from Table 2 in: [31]).....	29
Table 2.5 Summary of Outcomes of TENS Systematic Reviews to Show Efficacy of TENS (Modified from Table 1 in: [35]).....	34
Table 4.1: The selectable and configurable stages with different timing requirements for the proposed stimulator system.....	49
Table 4.2: The designed and simulated wireless based TENS stimulator system .....	49

## List of Acronyms

<b>Acronym</b>	<b>Description</b>
AC	Alternative Current
AD	Anno Domini/After Christ
ADC	Analog To Digital Converters
ALS	Anterolateral System
AL-TENS	Acupuncture-Like Tens
AM	Amplitude Modulation
ANT	Antenna
AREF	Analog Reference
ARM	Advanced Reduced Instruction Set Computer Machine
ASM	Assembly Computer Language
AVR	Advanced Virtual Reduced Instruction Set Computer Machine
BC	Before Christ
BOR	Brown-Out Reset
bps	Burst Per Second
CMOS	Complementary Metal Oxide Semiconductor
CNS	Central Nervous System
DAC	Digital To Analog Converters
DC	Direct Current
DRG	Dorsal Root Ganglion
DSP	Digital Signal Processing
E	Met-Enkephalin
EEPROM	Erasable Programmable Read-Only Memory
FPGAs	Field Programmable Gate Arrays
GABA	Glycine And Gamma-Amino Butyric Acid
GND	Ground
HDL	Hardware Description Language
ICSP	In-Circuit Serial Programming
I <sup>2</sup> C	Inter-Integrated Circuit
LCD	Liquid Crystal Display
LC	Inductor And Capacitor

LED	Light Emitting Diode
MISO	Master Input Slave Out
MOSFET	Metal Oxide Field Effect Transistor
MOSI	Master Out Slave In
MSSP	Master Synchronous Serial Port
nRM	Nucleus Raphe Magnus
NRZ	Non Return To Zero
OOK	On Off Keying
PAG	Periaqueductal Grey
PC	Personal Computer
PIC	Peripheral Interface Controller
PNS	Peripheral Nervous System
pps	Pulse Per Second
PWM	Pulse Width Modulation
RC	Resistance And Capacitance
RCTs	Randomized Controlled Trials
RF	Radio Frequency
RFs	Reticular Formations
RISC	Reduced Instruction Set Computer
ROM	Read-Only Memory
RVM	Rostral Ventromedial Medulla
RX	Receiver
SCL	Serial Clock Line
SDA	Serial Data Line
SFR	Special-Function Registers
SPI	Serial Peripheral Interconnect
T	Central Nociceptor Transmission Neurons
TENS	Transcutaneous Electrical Nerve Stimulation
TTL	Transistor-Transistor Logic
TWI	Two Wire Interface
TX	Transmitter

UART	Universal Asynchronous Receiver Transmitters
USART	Universal Synchronous/Asynchronous Receiver/Transmitter
USB	Universal Serial Bus
VCC	(Main) Supply Voltage
VIP	Vasoactive Intestinal Peptide
VPI	Ventral Posterior Inferior
VPL	Ventral Posterior Lateral

## List of Symbols

Symbols	Names
$\alpha$	Alpha
$\beta$	Beta
$\gamma$	Gamma
$\delta$	Delta

# 1. INTRODUCTION

## 1.1 Overview

Pain is the mental manifestation of a neurological response to various physiological and psychological ailments [1]. Sometimes pain corresponds to or serves as a warning of physical damage or biological dysfunction. Sometimes pain is a characteristic of a biological transition. In any event, control and alleviation of pain has been an important function of medicine for as long as medical practitioners have existed. The most common pain-control methods employ bio-active chemical agents that act to block neurotransmission pathways within the body [1]. However, sometimes such chemical agents are ineffective or produce unacceptable side effects. Consequently, transcutaneous electrical nerve stimulation (TENS) has also been employed to alleviate pain, and have been widely accepted as effective means for alleviating both acute and chronic pain. It is an attractive alternative to pharmaceuticals since it has no addictive properties. In addition, there are no known side effects to properly applied TENS therapy.

Transcutaneous electrical tissue stimulators generally comprise circuitry for generating electrical pulses, electrodes for attachment to the skin, and electrode leads for delivering the pulses to the electrodes [4, 6]. Transcutaneous stimulators are worn or carried outside the body and have electrodes secured to the skin over the affected area to apply the electrical stimulation thereto. Such systems heretofore have required the patient to run leads from the electrodes attached to the skin through his or her clothing to the location of the controller-generator unit. For many, the wires are a major drawback because they are awkward and complex. The result is that many patients discontinue the successful use of transcutaneous electrical tissue stimulation and select an alternative method of pain control such as drug therapy [4, 6]. Besides that, in countries like Ethiopia many barriers to analgesia prescribing, which include the community that it is acceptable to experience pain [3]. Even when the correct analgesics are prescribed, the long run drug/medicine cost is high and often not affordable by patients because of their living standards. For this reason, the number of death with this pain is high comparatively [2, 3].

More recent studies [4-7] have shown that a considerable number of TENS systems are used for different stimulation techniques like conventional, acupuncture-like and intense stimulation techniques independently, which makes them normally impossible to adjust for different physical condition without major redesign of both hardware and software. By taking all those recent

studies [4-7] as a platform for validating the final work of the research, a new prospect combined system which includes all the three techniques within a single system has been designed.

This work overcomes the problems encountered when using the above mentioned stimulation techniques independently, by providing a wireless/remotely controlled transcutaneous electrical tissue stimulator which can provide stimulation for the patient that is capable of delivering a variety of waveforms to patient tissue, with varying amplitude according to the patient's comfort level, so as to be capable of treating a variety of physical conditions both acute and chronic, and also provide new experience for patients.

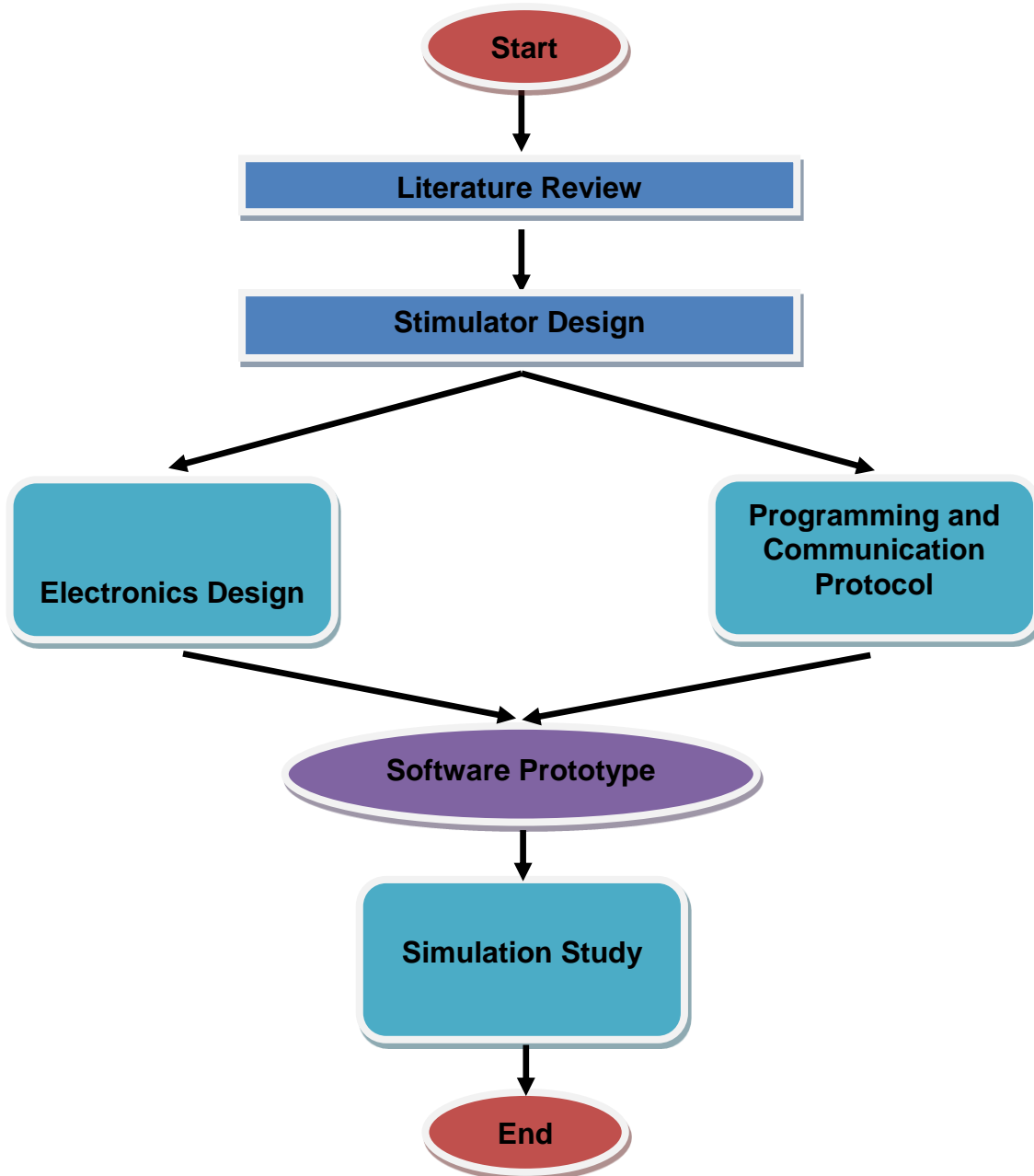
## **1.2 Problem Statement**

Electrical transcutaneous electrical nerve stimulation devices, which administer electrical stimulation through electrodes, applied to the skin of the individual being treated and provides specific (defined) waveforms to the users to treat specified physical conditions (illness). For many, the wires are a major drawback because they are awkward, bothersome, and unavoidably conspicuous. The result is that many patients discontinue the successful use of transcutaneous electrical tissue stimulation and select an alternative method of pain control such as drug therapy which has some side effects relatively. Even they have used the drug therapy; the drug cost is high and not affordable because of their living standard in country like Ethiopia.

## **1.3 Research Methodology**

In order to complete this research, the following procedures and research flow chart (Figure.1.1) has been taken:

- 1) Understanding an established conventional stimulator specification to be compared in developing the new stimulator.
- 2) Understanding the wireless module function and their specification to utilize in the new system of stimulator control and data transmission.
- 3) Designing a stimulation circuit, microcontroller-based interface circuit and wireless module.
- 4) Developing the software programming of the stimulator.
- 5) Simulating the software prototype.
- 6) Validating the result with simulation study.



**Figure 1.1:** Flow Chart for the Overall Research

## **1.4 Research Objectives**

### **1.4.1 Main Objective**

The main objective of this research is Designing and Developing a Wireless Based Transcutaneous Electrical Nerve Stimulator for Pain Control.

### **1.4.2 Specific Objectives**

The specific aims of the research are:

- Designing the stimulation circuit and a microcontroller-based interface circuit.
- Developing the software programming of the stimulator.
- Simulating the designed stimulator software prototype.
- Validating the result from the simulation study.

## **1.5 Research Scope**

The scope of this work is to provide design and simulation of a transcutaneous electrical tissue stimulator which could be capable of treating a variety of physical conditions. The system is expected to solve cable complexity and become user friendly. This thesis work is limited to design and simulation of TENS based on microcontroller-based interface circuit and wireless module.

## **1.6 Related Works**

Several researches in the past decade indicate that designing and developing wireless surface electrical nerve stimulator for controlling pain is highly feasible, but in this thesis, only four different published researches has been assessed in detail; this all meets a possibility that collectively shows such a design is feasible.

The following are the related researches that included in this thesis:

- “Local Application Microprocessor Based Nerve and Muscle Stimulator” [36]
- “Programmable Pain Reduction Device” [37]
- “Interactive Transcutaneous Electrical Nerve Stimulation Device” [38]
- “Design and Implementation of Wireless Transcutaneous Electrical Nerve Stimulator (TENS) for Smart Phone” [39]

### “Local Application Microprocessor Based Nerve and Muscle Stimulator” [36]

This thesis directed to a TENS-type therapeutic device, in general, and to a microprocessor controlled TENS-type system, in particular.

Basically; a transcutaneous electro neural stimulation (TENS) device employing microprocessor control of carrier pulse frequency, modulation pulse frequency, intensity, and frequency and amplitude modulation factors has been developed. The microprocessor monitors battery status and keypad-entered commands that select the various TENS modalities, and generates the driver

signals to produce the output waveform provided to a utilization device via a transformer arrangement. The microprocessor is programmed to calculate all stimulation Parameters which are stored in nonvolatile memory to provide concise and predictable programmed functions which can be updated as required. By selecting a program, the system may be programmed to relieve pain or reduce edema in the application area. Thus, a variety of therapeutic applications may be realized. The output pulse train employs a unique pulse modulation scheme which matches the carrier frequency to the electrode-tissue load for location specific applications. By pulse modulating the high frequency carrier and matching the carrier frequency to the electrode-tissue load, a more efficient energy transfer is realized. This matching significantly reduces the required amplitude of the electrode voltage pulse and reduces the overall power requirements for the system. In addition to enhanced power efficiency, the unpleasant burning sensation associated with most TENS stimulation units is virtually eliminated. The unit can be integrated into a hermetically sealed miniaturized composite package which allows the unit to be worn in a non-interfering manner at the treatment location.

#### “Programmable Pain Reduction Device” [37]

This thesis relates generally to a pain treatment device, and more particularly to transcutaneous electrical nerve stimulation (TENS) devices and methods for programming and operating such devices to maximize effectiveness.

Fundamentally, a remotely programmable medical device developed and designed on this thesis having: - a memory for storing a program, a patient interface (electrodes syringe, etc.), and a microprocessor for operating the patient interface under the control of the program. The program is constructed by a remote knowledge based analysis tool (database with fuzzy logic), accessible by the medical device over a network such as the Internet. The program, responsive to patient data entered into a client computer on the network, is then transmitted to the medical device as through the client computer to which the medical device is coupled via an interface docking terminal. The remotely programmed medical device is then used on the patient. Transcutaneous electrical nerve stimulation (TENS) devices are preferably programmed to output electrical stimulus signals of alternating high (80-100 HZ) and low frequency (2-5 HZ) with symmetric increase and decrease in waveform amplitude.

#### “Interactive Transcutaneous Electrical Nerve Stimulation Device” [38]

This work relates generally to the field of therapeutic devices, and more particularly relates to an interactive device for electrical stimulation of body tissue.

In fact; a wireless, handheld electrical therapy device delivers electrical pulses to a treatment area of a patient. In one embodiment, the device comprises a microcontroller-based pulse generator circuit selectively operable in a plurality of therapeutic modes. The device comprises an ergonomic housing adapted to be comfortably grasped by a user. A plurality of electrodes is disposed on a surface of the housing. In operation, a user brings the electrodes into contact with patient's skin at a location on the patient to be treated.

Electrical pulses are delivered between the electrodes, thereby electrically stimulating neural tissue at the treatment location. In one embodiment, the device is operable in a manual mode wherein the user selects from among a plurality of therapeutic regimens each corresponding to a set of predetermined operational parameters. Among the variable operational parameters are pulse amplitude, frequency, duration, damping, and shape. In another embodiment of the invention, the device is operable in an automatic mode wherein electrical conditions at the skin surface are periodically sensed and the operational parameters automatically adjusted to achieve optimal therapeutic effectiveness.

“Design and Implementation of Wireless Transcutaneous Electrical Nerve Stimulator (TNES) for Smart Phone” [39]

This work generally designs and implements generally a wireless transcutaneous electrical nerve stimulator (TNES) that is controlled by smart phone.

Actually; the proposed TENS in this thesis can be attached to the human arm with the help of the arm band for providing electrical stimuli via a disposable electrode. This stimulus help suppresses pain and increase skin temperature, and the electrical parameters of stimuli are controlled with the help of smart phone, and for implementation a modified boost converter, which continuously monitors the peak current output to ensure the electrical safety, is used.

## **1.7 Summary**

In summary, on section 1.6 the related works are discussed in detail, and figure out that a considerable number of TENS systems have been developed in the past, which works desirably in their target application. Those systems were designed for a specific control of pain, which

makes them impractical or normally impossible to adjust for other pain suppressing applications without major redesign of both hardware and software. Those stimulators that were developed TENS systems intended for use in various applications were limited in their use primarily due to restrictions in programming, stimulation capabilities, limited number of stimulation channels and user interface.

Consequently, by taking the above points in to consideration a wireless surface electrical nerve stimulator is proposed, which can be used by a patient hand. Further, the proposed system is capable of delivering a variety of waveforms to patient tissue according to the patient's comfort level, so as to be capable of treating a variety of physical conditions both acute and chronic, and providing a new prospect and medical experience for both acute and chronic patients country like Ethiopia.

## **1.8 Thesis Overview**

Chapter one gives a brief overview, problem statement scope of this work and also some related works done in the past by researchers across the globe.

Chapter two gives a background and short history about the nervous system and pain including its pathway and path physiologic mechanism and the pain cycle, and also provides overview of TENS, history, possible mechanism actions, and clinical efficacy.

Chapter Three outlines the system design and the methods used to implement the system. The architecture, and hardware and software design phases including the stimulation process reused to design the system and various practical aspects are illustrated.

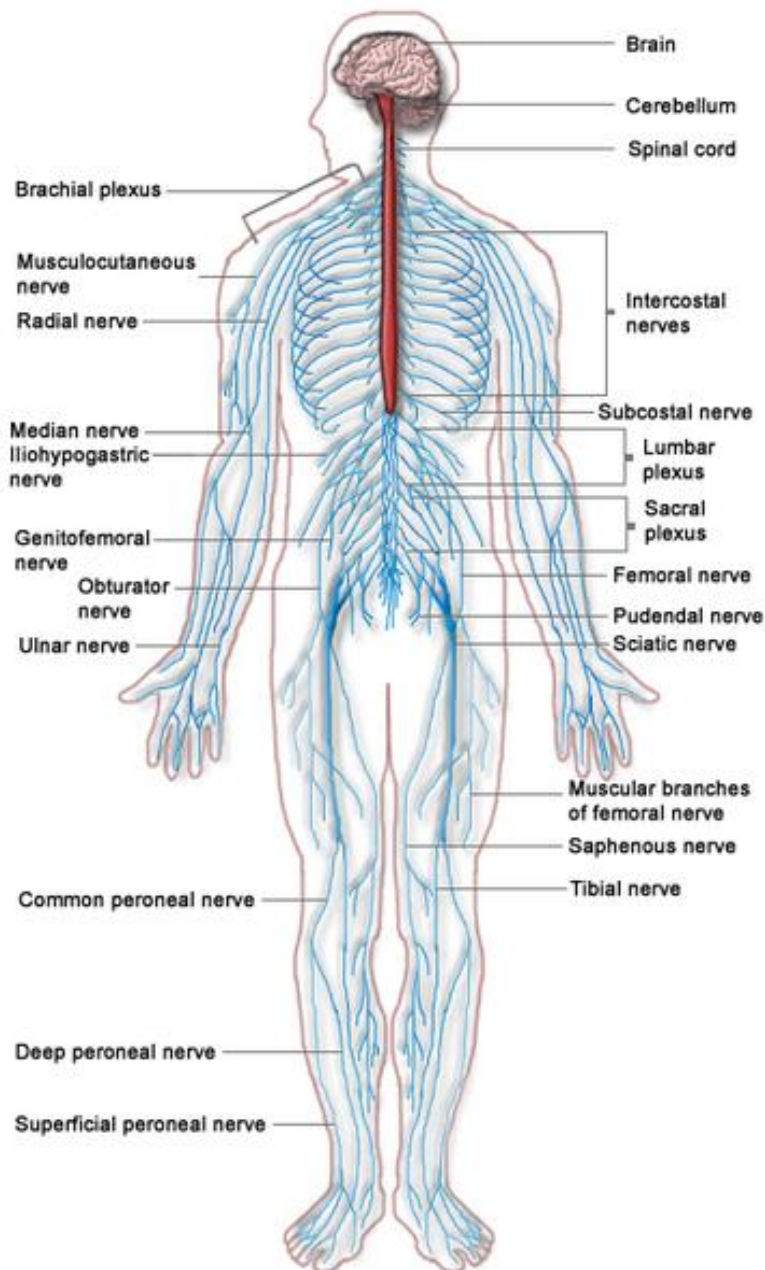
Chapter Four presents and discusses about the simulation results and give some accomplishments of the designed system.

Chapter Five provides research conclusion and recommendation for future work.

## 2. THEORETICAL AND PRACTICAL BACKGROUND

### 2.1 The Nervous System

The human nervous system allows us to interact with our environment in a way that is both elegant in its simplicity and fantastically incomprehensible in its subtlety. It is responsible for the rapid transfer of information in the form of electrical signals. In this section, understanding of the human nervous system and its function will be discussed in detail.



**Figure 2.1:** The human body and central and peripheral nervous systems.([8])

### **2.1.1 Overview of the Entire Nervous System**

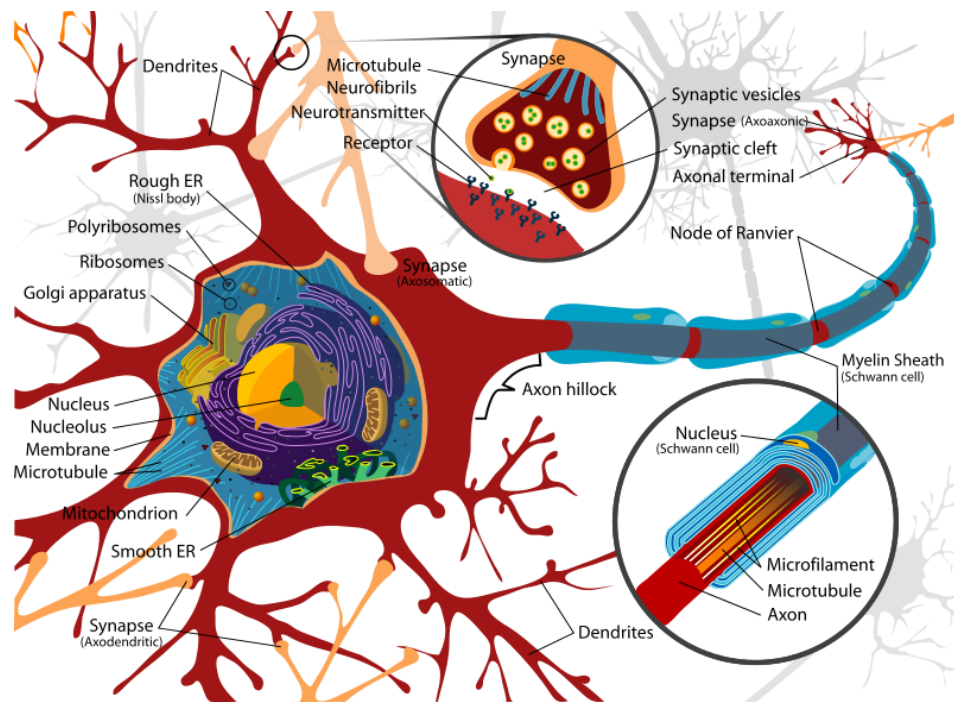
The nervous system has three main functions: sensory input, integration of data and motor output [1]. Sensory input is when the body gathers information or data, by way of neurons, glia and synapses. The nervous system is composed of excitable nerve cells called neurons and synapses that form between the neurons and connect them to centers throughout the body or to other neurons. These neurons operate on excitation or inhibition, and although nerve cells can vary in size and location, their communication with one another determine their function. These nerves conduct impulses from sensory receptors to the brain and spinal cord. The data is then processed by way of integration of data, which occurs only in the brain. After the brain has processed the information, impulses are then conducted from the brain and spinal cord to muscles and glands, which are called motor output, and also glia cells are found within tissues and are not excitable but help with myelination, ionic regulation and extracellular fluid [1].

The nervous system is comprised of two major parts, or subdivisions, the central nervous system (CNS) and the peripheral nervous system (PNS) [1, 8]. The CNS includes the brain and spinal cord. The brain is the body's "control center". The CNS has various centers located within it that carry out the sensory, motor and integration of data. These centers can be subdivided to Lower Centers (including the spinal cord and brain stem) and higher centers communicating with the brain via effectors. The PNS is a vast network of spinal and cranial nerves that are linked to the brain and the spinal cord. It contains sensory receptors which help in processing changes in the internal and external environment. This information is sent to the CNS via afferent sensory nerves. The PNS is then subdivided into the autonomic nervous system and the somatic nervous system [1, 8]. The autonomic has involuntary control of internal organs, blood vessels, smooth and cardiac muscles. The somatic has voluntary control of skin, bones, joints, and skeletal muscle. The two systems function together, by way of nerves from the PNS entering and becoming part of the CNS, and vice versa. In fact, a brief description of the nervous system at the cellular, organ, and patient level will be discussed below in detail, which provide necessary inputs for discussion of pain: what it is, how it's caused, and methods of controlling it [1, 8, 9].

At the cellular level the human nervous system contains about 1 trillion neurons; the great majority of these cells are concentrated in the central nervous system (CNS) [1, 8, 9]. The reminder comprises the peripheral nerve system, which is made up of sensory neurons that send

information from the body to the CNS and motor neurons that send information from the CNS to the body.

Basically most neurons are comprised of the same basic parts [1, 9]. The spinal motor neuron is illustrated in the figure below:



**Figure 2.2:** Diagram of a neuron. ([9])

The soma is the cell body of the neuron, which encloses the nucleus. One or more processes extend from this body. A unipolar neuron has only one process, a bipolar has two, and a multipolar neuron has three or more processes. The spinal motor neuron has five to seven. One process is usually much longer than the others and is known as the nerve fiber or axon. The shorter processes are called dendrites [1, 9]. The axon carries outgoing information to areas up to a meter away from the cell body. The first section of the axon is called the initial segment. The initial segment generates propagated electrical impulses. At the end region, the axon divides into several branches, which conclude at terminal ending. At this widening, known as the synapse, the neuron is in close contact with other nerve cells [1, 9]. The terminal ending store synaptic transmitters that the neuron secretes to communicate with other cells. Up to thousands of synapses, which bring in information from other nerve cells, cover the dendrites and cell body. Some promote, while other inhibit, excitation. Heat, electricity, chemicals, pressure, or other stimuli at the Input Region excite sensory neurons. These inputs sum together and propagate in

to the axon. If they are small, no information will be transmitted by the neuron. However, excitation above a certain threshold generates an action potential, or electrical impulse [1, 9].

In general, the neurons as shown above made from four key regions. The Input Region comprised of the dendrites and soma, integrates local potential changes from multiple synaptic connections. Next, a Generation Region which is the initial segment or the initial node of ranvier actually creates propagated action potentials when local potential change exceeds the threshold value. Then a conductile region releases synaptic transmitters, and the information is conveyed to other neurons. A long cylinder of material known as axoplasm, surrounded by an electrically excitable membrane, makes up the axon. Axon diameter and insulation by myelin, a protein-lipid complex composed of the cell membrane which is wrapped around the axon, determines conduction velocity. Neurons surrounded by this complex are deemed myelinated. The myelin sheath covers the axon except at this ending and at the Node of Ranvier. Nodes of Ranvier are about a micrometer in size and about a millimeter apart. Myelin significantly increases a neurons electrical insulation and, in turn, its conduction velocity. Some nerve cells are without the myelin wrapping; these are termed unmyelinated. Conduction velocity in unmyelinated neurons is much slower than in myelinated and is proportional to the square root of fiber diameter [10].

At the organ level the sensory neurons of the peripheral nervous system embedded in the dermis of the skin are pertinent interest or important with regards to transcutaneous electrical nerve stimulation (TENS) and gate theory. Peripheral neurons specialize to convey different type of information and are generally classified by either letter or number according to their specialization. (Table 2.1) classifies the neurons by letter and lists their function, axonal diameter, and electrical characteristics. (Table 2.2) then lists their less common numerical classification.

**Table 2.1:** Nerve fiber types in mammalian nerve (adopted from: [10])

Fiber Type	Function	Fiber Diameter (μm)	Conduction Velocity (m/s)	Spike Duration (ms)	Absolute Refractory Period (ms)

A $\alpha$	Proprioception; Somatic motor	12-20	70-120	0.4-0.5	0.4-1
A $\beta$	Touch, Pressure	5-12	30-70		
A $\gamma$	Motor to Muscle Spindles	3-6	15-30		
A $\delta$	Pain, cold, touch	2-5	12-30		
B	Preganglionic autonomic	Less than 3	3-15	1.2	1.2
Dorsal Root C	Pain, temperature, some mechanoreception, reflex responses	0.4-1.2	0.5-2	2	2
Sympathetic	Postganglionic sympathetics	0.3-1.3	0.7-2.3	2	2

A and B fibers are myelinated; C fibers are unmyelinated

**Table 2.2:** Numerical classification of sensory neurons (adopted from: [10])

Number	Origin	Fiber Type
Ia	Muscle spindle, annulo-spinal ending.	A $\alpha$
Ib	Golgi tendon organ.	A $\alpha$
II	Muscle spindle, flower-spray ending; touch, pressure.	A $\beta$
III	Pain and cold receptors; some touch receptors	A $\delta$
IV	Pain, temperature, and other receptors.	Dorsal Root C

Note that small diameter A- $\delta$  and dorsal root C fibers are the nociceptors-nerve fibers that convey painful excitation. The A- $\delta$  fibers are myelinated and conduct information much more rapidly than the C fibers. Pain provoked by A- $\delta$  fibers is usually of short duration but is sharp, distinct, and well localized. Pain carried by C fibers is more of the dull, aching variety that is diffuse and long lasting [10]. Also notice that the much larger diameter and faster conducting A- $\beta$  fibers transmit touch and pressure stimuli.

The pain level encompasses the whole of the human nervous system, which influences reflexes, hearing, vision, smell, taste, posture, autonomic actions, emotions, memory, behavior,

temperature, touch, pain, and a host of other life-sustaining activities. The nervous system is far too broad a topic to see in detail, but of relevant to transcutaneous electrical nerve stimulation (TENS) are the transmission pathways governing touch and pain.

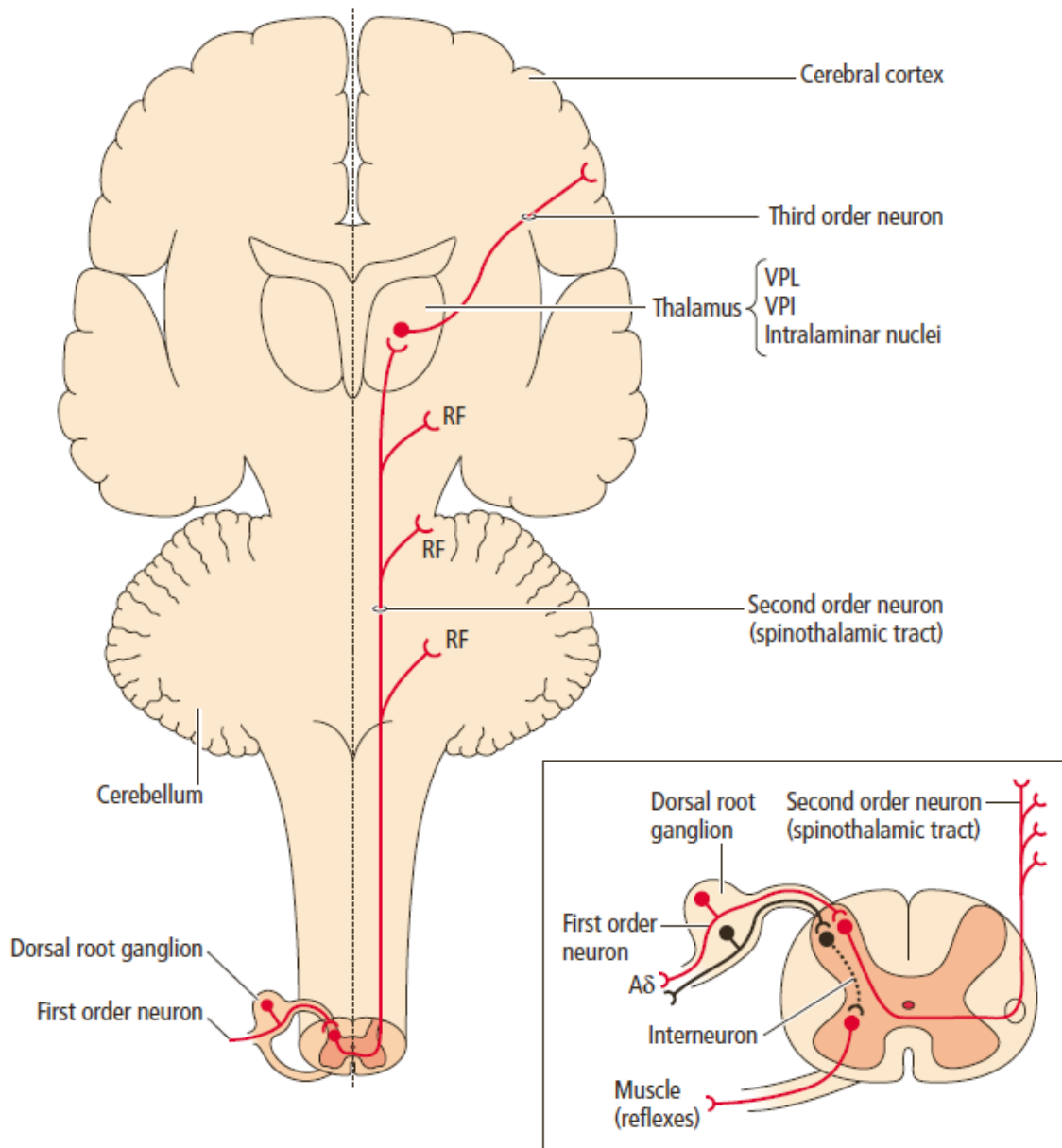
How does stimulation of sensory neurons at a location significantly remote from the brain enter consciousness; affect emotion, memory, conditioning, etc. and provoke a coordinated response from the body? Is it possible to modulate the information passed to the brain and thereby diminish or relieve the symptomatic aspects of pain? On this part the anterolateral pathways system is attempted to discuss in somewhat general terms [10].

The anterolateral system pathways transmit nociceptive, thermal, and nondiscriminatory touch information to higher brain centers, generally by a sequence of three neurons and interneuron's as seen in the Figure 2.3.

The neuron sequence consists of [11]:

- 1) A first order neuron (pseudo-unipolar neuron) whose cell body is located in a dorsal root ganglion. It transmits sensory information from peripheral structures to the dorsal (posterior) horn of the spinal cord.
- 2) A second order neuron whose cell body is located within the dorsal horn of the spinal cord, and whose axon usually decussates and ascends:
  - In the direct pathway of the ALS (spinothalamic tract) to synapse in the contralateral thalamus, and sending some collaterals to the reticular formation;
  - In the indirect pathway of the ALS (spinoreticular tract) to synapse in the reticular formation, and sending some collaterals to the thalamus; or
  - As spinomesencephalic, spinotectal, or spinohypothalamic fibers to synapse in several brainstem nuclei.
- 3) A third order neuron whose cell body is located in the thalamus, and whose axon ascends ipsilaterally to terminate in the somatosensory cortex.

In some cases, the first order neuron may synapse with an interneuron that resides entirely within the dorsal horn, and whose axon synapses with the second order neuron [11]. Note the first order neuron in the dorsal root ganglion, the second order neuron in the dorsal horn of the spinal cord, and the third order neuron in the thalamus. The second order neuron sends collaterals to the reticular formation (RF).



**Figure 2.3:** The direct pathway of the anterolateral system ([11])

The thalamus (VPI (ventral posterior inferior), VPL (ventral posterior lateral) and intralaminar nuclei) regulates emotion while the cerebral cortex deals with higher order functions such as memory and learning. Although great progress has been made in determining where different forms of information are progressed or stored in the brain, how such information is stored and processed into a response is still unclear.

Hence, for transcutaneous electrical nerve stimulation (TENS), perception is much greater importance than response and acts at lower levels in the spinal cord. Although, studies have

shown that pain can be modulated directly in the brain [11]. For this research it is unnecessary to discuss processes of the brain in more detail at this time.

## **2.2 Pain**

Pain is a vital function of the nervous system in providing the body with a warning of potential or actual injury. It is both a sensory and emotional experience, affected by psychological factors such as past experiences, beliefs about pain, fear or anxiety [12].

Physiologically, pain is divided into two categories/classes: nociceptive and neuropathic [13]. Nociceptive pain is the perception of painful sensation and it is generated by an injury that activates nociceptors in peripheral tissues. Reports suggest that the nociceptive system may be altered in chronic inflammatory pain. Neuropathic pain is the pathology of the somatosensory system, either in its peripheral elements (peripheral neuropathic pain) or in the CNS (central neuropathic pain). It is either central or peripheral (outer surface), depending on the origin of the stimulus; for example, direct damage to the spinal cord or the peripheral nerves, respectively.

This section mainly provides an overview of the pathophysiologic mechanisms of pain and the important pain pathways including the pain cycle.

Pain receptors, transmission of pain signals to the spinal cord and pain pathways within the spinal cord will also be discussed. How pain can be modulated at different levels along the pathway and different types of pain including nociceptors (visceral or somatic) and neuropathic pain will also be part of the discussion.

### **2.2.1 The Pain Pathway and Pathophysiologic Mechanisms of Pain**

#### **Nociceptors:**

Nociceptors are the specialized sensory receptors responsible for the detection of noxious (unpleasant) stimuli, transforming the stimuli into electrical signals, which are then conducted to the central nervous system [1, 12, 13]. They are the free nerve endings of primary afferent A $\delta$  and C fibers.

Distributed throughout the body (skin, viscera, muscles, joints, meninges) they can be stimulated by mechanical, thermal or chemical stimuli.

Nociceptive pain is further divided into two categories: somatic and visceral [13]. Somatic body pain, which in humans has been described as localized, sharp, aching, or throbbing pain,

originates from skin and connective tissues, including the muscles, joints and bones. Somatic pain originating in the skin is called superficial pain. If it originates in the connective tissues such as the muscles, bones and joints, it is called deep pain [13]. In other words, somatic pain refers to pain originating from the periphery and can be, in most cases, well localized. Visceral (organ) pain is usually dull or hard to localize and originates from receptors in the heart, lungs, kidneys, liver, gastro-intestinal tract, uterus or bladder. Painful states are caused particularly by tissue or nerve damage, inflammatory processes, viral infections or demyelination and are characterized by pain hypersensitivity. Visceral pain arises from the viscera suggested that the sensitivity of viscera to mechanical, thermal or chemical stimuli is very different. Information from certain regions of viscera converges on spinal neurons and pathways that also convey information from somatic structures. For example, some cows exhibit an extreme sensitivity in the region of the sternum, when they suffer from traumatic peritonitis caused by a wire or nail perforating the wall of the fore- stomachs [1, 13]. Generally, inflammatory mediators are released from damaged tissue and can stimulate nociceptors directly. They can also act to reduce the activation threshold of nociceptors so that the stimulation required to cause activation is less. This process is called primary sensitization [13].

Nociceptive pain can be acute (short-lived, remitting) or persistent (long-lived, chronic) and may primarily involve injury to somatic or visceral tissues [12, 13]. Pain that is inferred to be related to on-going activation of nociceptors that innervate somatic structures, such as bone, joint, muscle and connective tissues, is termed as “somatic pain”. This pain is recognized by identification of a lesion and characteristics that typically include a well-localized site and an experience described as aching, squeezing, stabbing or throbbing. Arthritis and metastatic bone pain are the examples of somatic pain. Pain arising from stimulation of afferent receptors in the viscera is referred to as visceral pain. Visceral pain caused by obstruction of hollow viscous is poorly localized and is often described as cramping and gnawing, with a daily pattern of varying intensity; however, when organ capsules or other structures such as myocardium are involved, the pain usually is well localized and described as sharp, stabbing or throbbing, descriptors similar to those associated with somatic pain. Visceral pain is usually described as more diffuse and unpleasant than somatic pain and the diffuse nature of true visceral pain is probably due to the low density of visceral sensory innervations and extensive divergence of the visceral input within the CNS.

### **2.2.1.1 Primary Afferent Fibres [14-16]**

In addition to the A $\delta$  and C fibres that carry noxious sensory information, there are primary afferent A $\beta$  fibres that carry non-noxious stimuli. Each of these fibre types possesses different characteristics that allow the transmission of particular types of sensory information (Table 2.1).

- A $\beta$  fibres are highly myelinated and of large diameter, therefore allowing rapid signal conduction. They have a low activation threshold and usually respond to light touch and transmit no noxious stimuli.
- A $\delta$  fibres are lightly myelinated and smaller diameter, and hence conduct more slowly than A $\beta$  fibres. They respond to mechanical and thermal stimuli. They carry rapid, sharp pain and are responsible for the initial reflex response to acute pain.
- C fibres are unmyelinated and are also the smallest type of primary afferent fibre. Hence, they demonstrate the slowest conduction. C fibres are polymodal, responding to chemical, mechanical and thermal stimuli. C fibre activation leads to slow, burning pain.

### **2.2.1.2 Dorsal Horn of the Spinal Cord [14-16]**

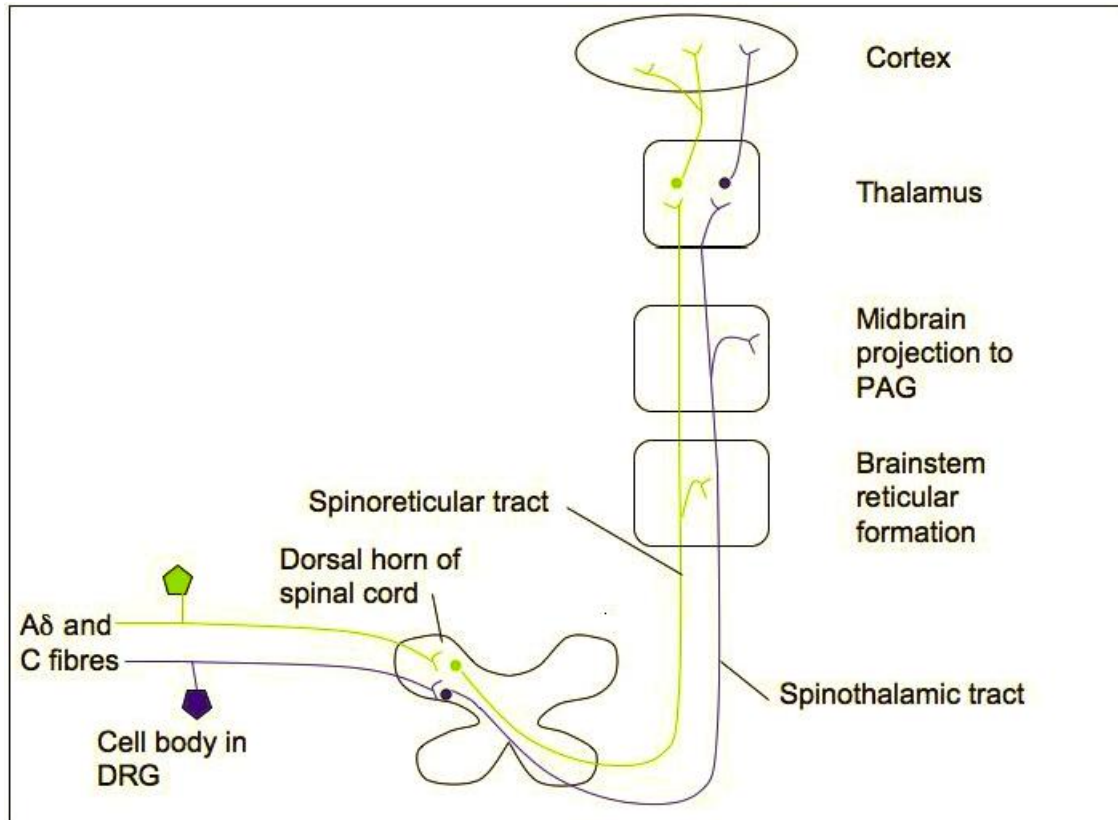
A $\delta$  and C fibres synapse with secondary afferent neurones in the dorsal horn of the spinal cord. The dorsal horn can be divided histologically into ten layers called Rexed laminae. A $\delta$  and C fibres transmit information to nociceptive specific neurones in Rexed lamina I and II, in addition to projections to other laminae. Primary afferent terminals release a number of excitatory neurotransmitters including glutamate and substance P. Complex interactions occur in the dorsal horn between afferent neurones, interneurons and descending modulatory pathways (see below). These interactions determine activity of the secondary afferent neurones. Glycine and gamma-aminobutyric acid (GABA) are important neurotransmitters acting at inhibitory interneurons.

### **2.2.1.3 Ascending Tracts in the Spinal Cord [14-16]**

There are two main pathways that carry nociceptive signals to higher centres in the brain.

- The spinothalamic tract: secondary afferent neurones decussate within a few segments of the level of entry into the spinal cord and ascend in the contralateral spinothalamic tract to nuclei within the thalamus. Third order neurones then ascend to terminate in the somatosensory cortex. There are also projections to the periaqueductal grey matter (PAG). The spinothalamic tract transmits signals that are important for pain localization.

- The spinothalamic tract: fibres also decussate and ascend the contralateral cord to reach the brainstem reticular formation, before projecting to the thalamus and hypothalamus. There are many further projections to the cortex. This pathway is involved in the emotional aspects of pain.



**Figure 2.4:** Ascending pain pathways. DRG dorsal root ganglion, PAG periaqueductal grey matter (Adopted from: [14])

#### 2.2.1.4 Inhibition of Pain Transmission [11, 15]

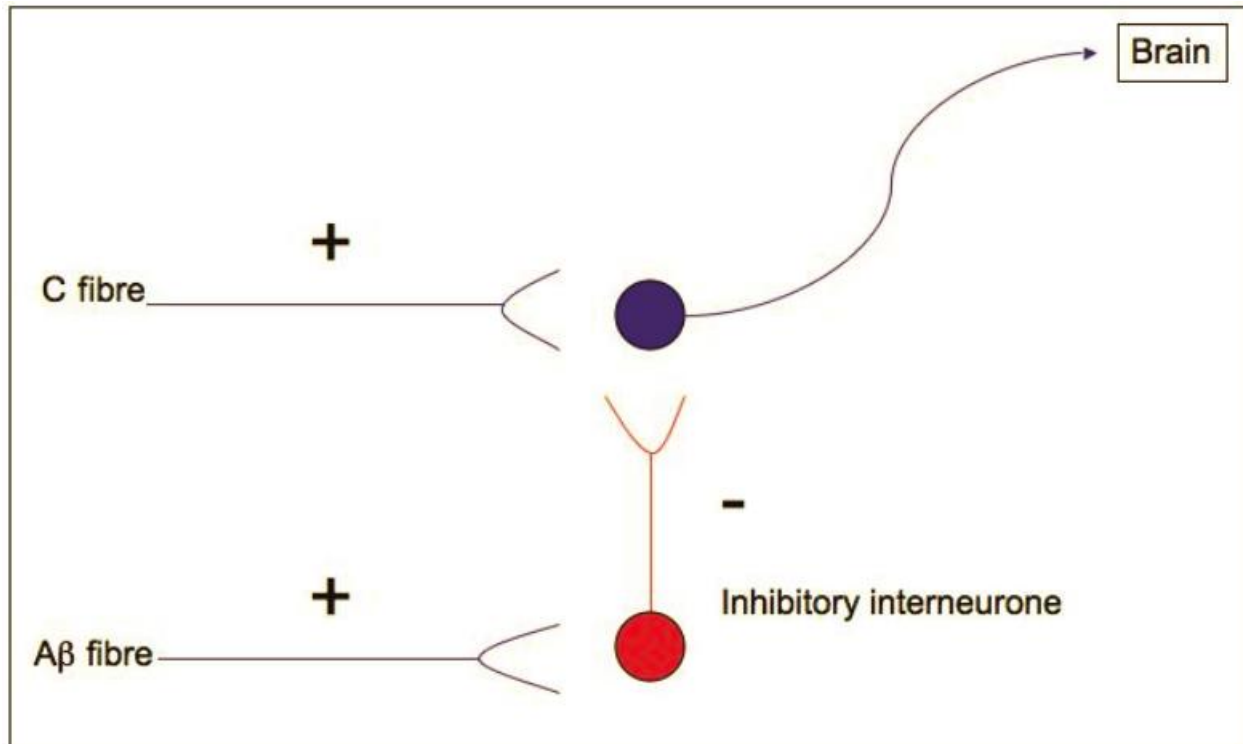
There are mechanisms that act to inhibit pain transmission at the spinal cord level and via descending inhibition from higher centers.

##### 2.2.1.4.1 Gate Control Theory of Pain [14, 15]

The gate control theory of pain describes a process of inhibitory pain modulation at the spinal cord level [15]. It helps to explain why when we bang our head; it feels better when we rub it. By activating Aβ fibres with tactile, non-noxious stimuli inhibitory interneurons in the dorsal horn are activated leading to inhibition of pain signals transmitted via C fibres (Figure 2.5).

#### 2.2.1.4.2 Descending Inhibition Modulation [11, 15]

The periaqueductal grey (PAG) in the midbrain and the rostral ventromedial medulla (RVM) are two important areas of the brain involved in descending inhibitory modulation. Both these centres contain high concentrations of opioid receptors and endogenous opioids, which helps explain why opioids are analgesic. Descending pathways project to the dorsal horn and inhibit pain transmission. These pathways are monoaminergic, utilizing noradrenaline and serotonin as neurotransmitters.



**Figure 2.5:** Gate control theory of pain, Stimulation of Aβ fibres activates inhibitory interneurons in the dorsal horn. (Adopted from: [16])

#### 2.2.1.4.3 Neuropathic pain [12, 13]

Neuropathic pain is caused by damage to nerves in the central or peripheral nervous system. Damage can be due a number of mechanisms including trauma or surgery, diabetes mellitus, chemotherapy, radiotherapy, ischaemia, infection or malignancy.

Neuropathic pain has some different characteristics to nociceptive pain. Pain is more likely to be spontaneous and is described as burning or 'like an electric shock'. Pain may be experienced in response to a stimulus that does not usually cause pain (allodynia), or there may be a heightened response to a stimulus that is usually painful (hyperalgesia).

**Table 2.3:** Useful definitions (Adopted from [12])

Term	Definition
Pain	“An unpleasant sensory and emotional experience associated with actual or potential tissue damage, or described in terms of such damage.”
Nociceptor	“A high-threshold sensory receptor of the peripheral somatosensory nervous system that is capable of transducing and encoding noxious stimuli.”
Hyperalgesia	“Increased pain from a stimulus that normally provokes pain.”
Neuropathic pain	“Pain caused by a lesion or disease of the somatosensory nervous system.”
Allodynia	“Pain due to a stimulus that does not normally provoke pain.”
Sensitization	“Increased responsiveness of nociceptive neurons to their normal input, and/or recruitment of a response to normally sub threshold inputs.”

In general, Pain is both a sensory and emotional experience, and patients past experiences, fears and anxieties can play an important role. Pain transmission is a result of complex peripheral and central processes. These processes can be modulated at different levels and pain perception is a result of the balance between facilitator and inhibitory interactions.

So far the discussion above, investigating the effects of pain processing and looking for novel drugs or other means of controlling mechanisms to block channels involved in pain transmission is very important.

### **2.2.2 The Pain Cycle [17]**

The Cycle of Pain illustrates the problems that often happen when you live with pain. It is very common for one problem to lead to another, trapping you in a constant ‘vicious cycle’. This vicious cycle of injury leading to body and behavior changes which makes the pain worse. Many people with pain have found ways to help themselves with these issues. It is possible to break or change this cycle of how pain controls your life.



**Figure 2.6:** The Pain Cycle (Adopted from: [17])

### 2.2.2. 1 Breaking the Cycle

The pain cycle can be interrupted by using different means of techniques, the most common alternative ways are:

- Medications: Medications are used to help you sleep, for pain control, and to change your mood
- Exercise: Aqua-therapy and Physical therapy, combined with stretching and aerobic activity can help if done properly and under supervision
- Emotion: Learning biofeedback or seeing a pain psychologist can help get you back in control of your life.

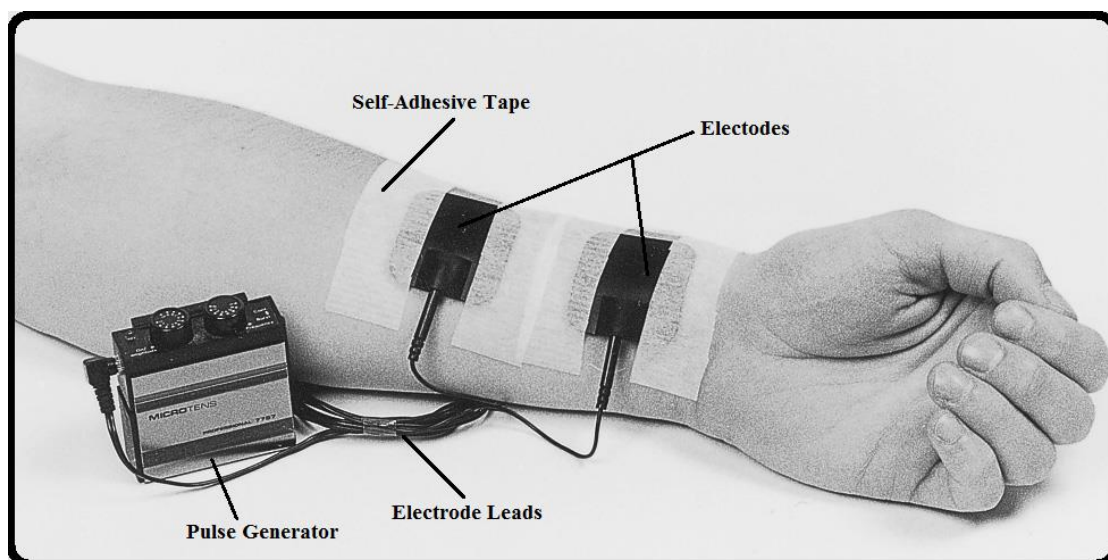
- Electrical Nerve Stimulation: Injecting electrical impulse to the surface of the human body which suppressed pain.

## 2.3 TENS, A New Modal Quality for Pain Modulation

This section begins with some overview of TENS and then discusses in detail about history of medical electricity, defining TENS and its possible mechanisms of action. Finally, clinical efficacy is addressed.

### 2.3.1 Overview of TENS

In broad terms TENS (transcutaneous electrical nerve stimulation) is a procedure that applies controlled electrical impulse on the skin to the nervous system in order to reduce pain [19]. Transcutaneous electrical nerve stimulation (TENS) is used by health care professionals throughout the world to provide pain relief for a wide range of conditions, including postoperative pain, labour pain and chronic pain [18, 19]. During TENS, electrical currents are generated by a stimulating device and delivered across the intact surface of the skin via conducting pads called electrodes (Figure-2.7). The popularity of TENS has grown because it is noninvasive, easy to administer and has few side-effects or drug interactions. There is no potential for toxicity or overdose and patients can administer TENS themselves at home and titrate the dosage of treatment as required. “When compared with long-term drug therapy, TENS treatment is considerably cheaper” [20]. Recently, systematic reviews have challenged claims that TENS is clinically effective [18-20].



**Figure 2.7:** A standard TENS device. (Modified from [19])

An electrical pulse generator delivers currents via conducting electrodes attached to the intact surface of the skin. Traditionally, carbon rubber electrodes smeared with conducting gel and attached to the skin using self-adhesive tape were used to deliver the electrical currents.

### **2.3.2 A Brief History of Medical Electricity**

There is evidence that ancient Egyptians used electrogenic fish to treat ailments in 2500BC, although the Roman Physician Scribonius Largus is credited with the first documented report of the use of electrogenic fish in medicine in AD46 [21]. The development of electrostatic generators in the eighteenth century increased the use of medical electricity, although its popularity declined in the nineteenth and early twentieth century due to variable clinical results and the development of alternative treatments [22]. Interest in the use of electricity to relieve pain was reawakened and provided a physiological rationale for electroanalgesic effects. They proposed that transmission of noxious information could be inhibited by activity in large diameter peripheral afferents or by activity in pain-inhibitory pathways descending from the brain. [23] They used high-frequency percutaneous electrical stimulation to activate large diameter peripheral afferents artificially and found that this relieved chronic pain in patients. Pain relief was also demonstrated when electrical currents were used to stimulate the periaqueductal grey (PAG) region of the midbrain [24], which is part of the descending pain-inhibitory pathway. [25] They found that electrical stimulation of the dorsal columns, which form the central transmission pathway of large diameter peripheral afferents, also produced pain relief. TENS was used to predict the success of dorsal column stimulation implants until it was realized that it could be used as a successful modality on its own [26, 27].

### **2.3.3 Pain and TENS [6, 19]**

In a TENS electrode circuit, one electrode is positively charged (anode) and the other negatively charged (cathode). An action potential (nerve impulse) is initiated in the underlying nerve fibres by the flow of current between two TENS electrodes. TENS is believed to relieve pain by several mechanisms which involve the stimulation of specific types of nerve fibres:

- Blocking the information travelling along the nociceptive fibres (i.e. those that produce pain) through stimulation of the large diameter afferent A $\beta$  fibres; and,
- Through the release of the body's endogenous opioids by stimulation of the small diameter afferent and motor fibres.

The type of nerve fibre stimulated, and thus the mechanism of pain relief, are determined by the stimulation parameters that are set on the TENS unit.

### 2.3.4 Stimulation Parameters

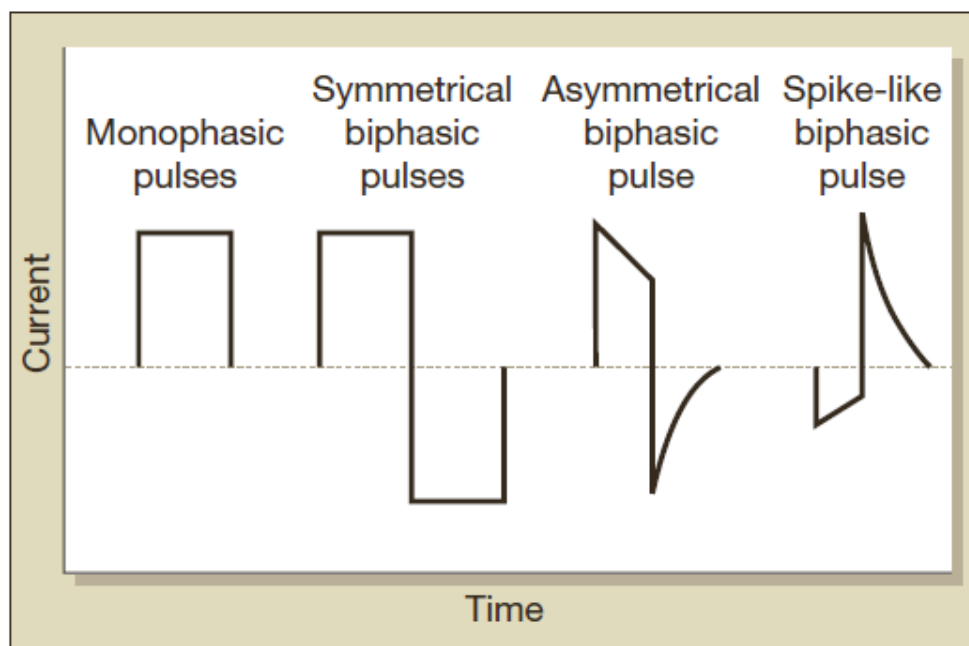
This section briefly describes the parameters of current, waveform, frequency, pulse duration and intensity; this is followed by a description of the four different modes of TENS that are basically different combinations of these parameters.

#### 2.3.4.1 Current

TENS is a pulsed current, i.e. a current in which the unidirectional or bidirectional flow of current periodically ceases over time.

#### 2.3.4.2 Waveform

Mostly TENS devices produce symmetrical, asymmetric or spike like biphasic wave forms. A few devices produce monophasic pulses [28]. Usually TENS waveforms are described as asymmetrical biphasic rectangular or symmetrical biphasic rectangular; (Figure-2.8) shows a few common pulse waveforms used in TENS.



**Figure 2.8:** Common Wave Forms used by TENS. (Adopted from [28])

A biphasic waveform means that current flows in both directions, therefore each electrode acts as a cathode (negative) for some part of the waveform. The wave form therefore has two

components (or phases), a positive and a negative component which represent the change in current flow. TENS waveforms usually have a zero net direct current (DC); this means that the amount of charge under the positive portion of the waveform is equal to the amount of charge under the negative portion of the waveform [28]. The production of a zero net DC reduces the likelihood of chemical skin irritation; a direct current can potentially cause skin irritation due to the buildup of ions of one charge under the electrodes.

### **2.3.4.3 Frequency**

The frequency of a current refers to the number of pulses delivered per second; therefore, a frequency of 200Hz means that 200 pulses are delivered per second.

### **2.3.4.4 Pulse Duration/Width**

The unit of pulse duration is usually given in microseconds ( $\mu\text{s}$ ) which are units of time, hence it is more correct to use the term ‘duration’ rather than ‘width’. The pulse duration is usually defined as the duration of only the positive component of the waveform. TENS pulse durations are in the  $\mu\text{s}$  range ( $1\mu\text{s} = 1 \times 10^{-6}\text{s}$ ).

### **2.3.4.4 Intensity/Amplitude**

Intensity refers to the magnitude of current or voltage applied by the TENS unit. TENS units are typically designed with a constant current or constant voltage output. Basically this means that either the voltage or current (respectively) will vary to maintain a constant current or voltage amplitude (within limits) as the impedance (resistance) of the electrode-patient system changes. The intensity of a constant current unit is measured in milliamps and the intensity of a constant voltage unit is measured in volts.

In general terms, the stimulation parameters like frequency, pulse width, and amplitude could be changed to activate different pain modulation mechanisms. Frequency refers to the number of electrical waveforms delivered per second, pulse width is the duration of each waveform, and amplitude refers to the height of each pulse above baseline. Skin resistance, body weight and surface electrode all influence amplitude. Thus, amplitude is often adjusted on a patient to patient basis in the milliamp range in order to find an optimum setting [29]. Frequencies used range from 1-200Hz, while pulse widths vary between 0 and about 500  $\mu\text{s}$ . Much progress has been made in the clinical use of TENS since its inception.

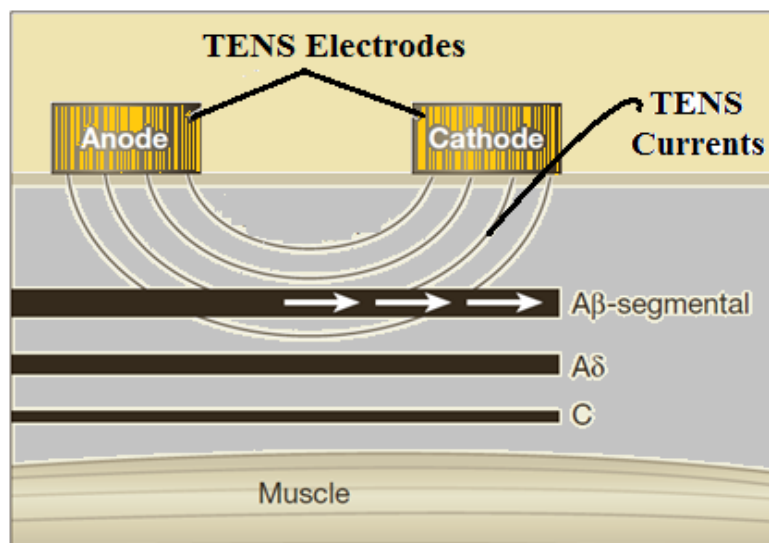
### 2.3.5 TENS Modes

Patients who are not comfortable with one set of parameters are often more receptive to a different mode. The common types of TENS described in the literature are [29, 30]:

- Conventional TENS;
- Acupuncture-like TENS (AL-TENS);
- Intense TENS;

#### 2.3.5.1 Conventional TENS

Conventional TENS are mostly used to activate selectively large diameter A $\beta$  fibres without concurrently activating small diameter A $\delta$  and C (pain-related) fibres as shown on (Figure-2.9). Evidence from animal and human studies supports the hypothesis that conventional TENS produces segmental analgesia with a rapid onset and offset and which is localized to the dermatome. Theoretically, high-frequency (10-250pps), low-intensity pulsed currents would be most effective in selectively activating large diameter fibres, although in practice this will be achieved whenever the TENS user reports that they experience a comfortable paraesthesia beneath the electrodes.



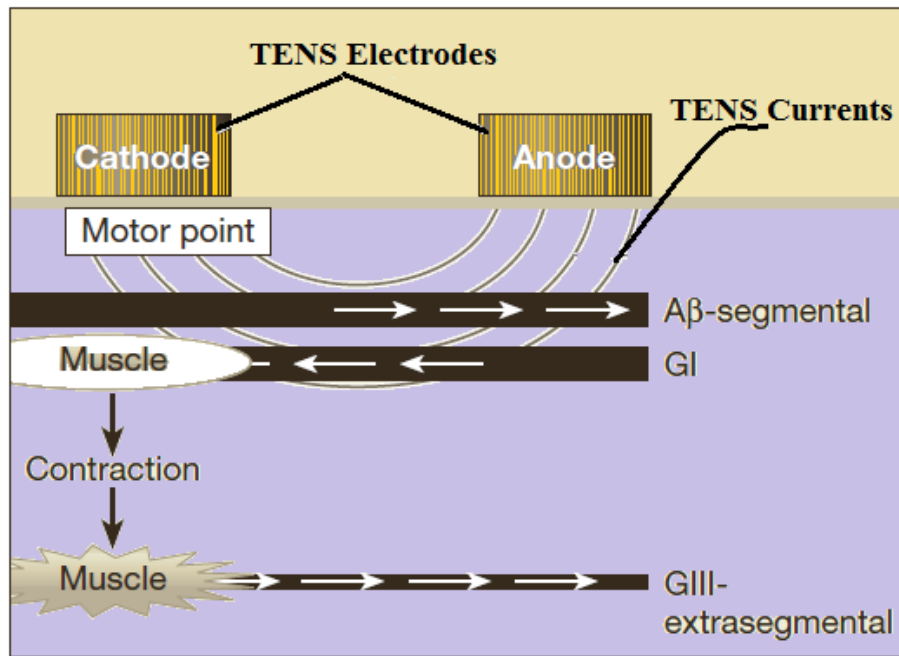
**Figure 2.9:** Conventional TENS used to selectively activate non-noxious cutaneous afferents (A $\beta$ ) to initiate segmental anti-nociceptive mechanisms. (Modified from Figure 17.8 in [19])

Note that the arrows indicate selective activation of nerve fibre transmitting impulses towards the central nervous system.

During conventional TENS currents are usually delivered between 10 and 200 pps., and 100  $\mu$ s and 200  $\mu$ s with pulse amplitude titrated to produce a strong comfortable and non-painful paraesthesia. As large diameter fibres have short refractory periods they can generate nerve impulses at high frequencies. This means that they are more capable to generate high-frequency volleys of nerve impulses when high-frequency currents are delivered. Thus, greater afferent barrages will be produced in large diameter nerve fibres when high frequencies (10-200 pps.) are used. The pattern of pulse delivery is usually continuous, although conventional TENS can also be achieved by delivering the pulses in 'bursts' or 'trains' and this has been described by some authors as pulsed or burst TENS [30, 31]. It is likely that continuous TENS and burst TENS produce similar effects when delivered at a strong but comfortable level without concurrent muscle twitches.

#### **2.3.5.2 Acupuncture-like TENS (AL-TENS)**

The purpose of AL-TENS is to generate activity in small diameter muscle afferents ( $A\delta$  or Group III) arising from muscles (ergoreceptors) by the induction of phasic muscle twitches as shown on (Figure-2.10) below. This is achieved indirectly by delivering currents at low frequencies (1–10 Hz) at high but non painful intensities over motor points in order to activate  $A\alpha$  efferents resulting in a forceful but non painful phasic muscle twitch [32]. The subsequent volley of impulses from muscle afferents mediates an extra-segmental anti-nociceptive mechanism and the release of endogenous opioid peptides in a manner similar to that suggested for acupuncture [32]. Low frequency burst patterns of pulse delivery were incorporated in TENS devices because they were found to be more comfortable than low-frequency single pulses in producing muscle twitches [32]. It should be remembered that currents delivered during AL-TENS will also activate  $A\beta$  during their passage through the skin, leading to segmental analgesia. AL-TENS has also been described as the delivery of TENS to acupuncture points without reference being made to the presence of muscle contractions.

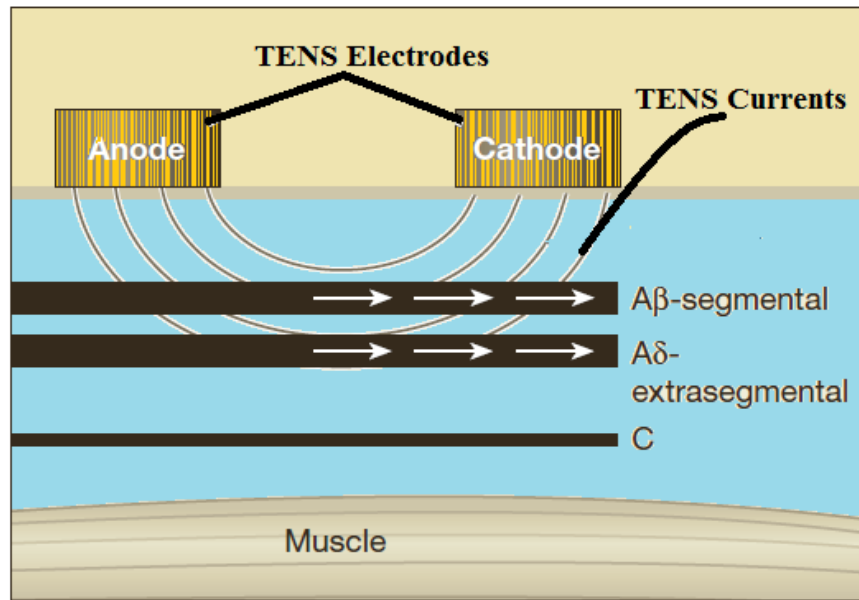


**Figure 2.10:** AL-TENS basically used to selectively activate large diameter motor efferents to elicit a non-painful muscle twitch. (Modified from Figure 17.9 in: [19])

This muscle twitch generates activity in ergoreceptors and small diameter muscle afferents to initiate extra-segmental anti-nociceptive mechanisms. In addition, A $\beta$  afferents are also likely to become active. Arrows indicate direction of relevant impulse information

### 2.3.5.3 Intense TENS

The purpose of intense TENS is to activate small diameter A $\delta$  cutaneous afferents by delivering TENS over peripheral nerves arising from the site of pain at an intensity that is just tolerable to the patient as shown on (Figure-2.11) [33]. Currents are administered at high frequencies (up to 150 pps) to prevent phasic muscle twitches that would be too forceful for the patient to tolerate. Cutaneous A $\delta$  afferent activity has been shown to block transmission of nociceptive information in peripheral nerves and to activate extra-segmental anti-nociceptive mechanisms. Intense TENS will also activate A $\beta$  fibres, producing segmental anti-nociceptive effects. As intense TENS acts in part as a counter-irritant, it can be delivered only for a short time, but it may prove useful postoperatively and for minor surgical procedures and such as wound dressing and suture removal [34].



**Figure 2.11:** The purpose of intense TENS is to activate noxious cutaneous afferents (A $\delta$ ) to initiate extra-segmental anti-nociceptive mechanisms and peripheral blockade of nociceptive impulses travelling in A $\delta$  fibres. (Modified from Figure 17.9 in: [31])

In addition, A $\beta$  afferents are also likely to become active. Arrows indicate direction of relevant impulse information.

From different researches none of the above TENS modalities are used in clinical practice for any one in today's Ethiopia, but from researched thesis and other countries experience a conventional TENS is most commonly used TENS modality. AL-TENS and intense TENS are used only in specific situations. Despite a large published literature on TENS, there is a lack of good quality and systematic experimental work that has directly compared the clinical effectiveness and analgesic profiles of these types of TENS.

**Table 2.4:** TENS techniques that can be achieved using a standard TENS device. (Modified from Table 2 in: [31])

	Conventional TENS	AL-TENS	Intense TENS
Purpose of currents	Selective activation of non-noxious cutaneous afferents (e.g. A $\beta$ fibres from mechanoreceptors)	Selective activation of motor efferents to generate a muscle twitch and activity in non-noxious muscle	Activation of noxious activation of noxious 'pinprick' cutaneous afferents (i.e. A $\beta$ fibres from

		afferents (i.e. GIII fibres from ergoreceptors)	nociceptors
Theoretical optimum output characteristics	High frequency/low intensity: Amplitude = low Duration = 100–200 $\mu$ s Frequency = 10–200 pps Pattern = continuous	Low frequency/high intensity: Amplitude = high Duration = 100–200 $\mu$ s Frequency = 2 bps and 100 pps within burst Pattern = burst	High frequency/high intensity: Amplitude = high Duration = 1000 $\mu$ s Frequency = 200 pps Pattern = continuous
Sensory experience during stimulation	Strong but comfortable Electrical paraesthesia with minimal muscle contraction	Strong but comfortable muscle twitches	Highest tolerable level with minimal muscle contraction
Electrode position	Site of pain Dermatomal	Motor point/muscle at site of pain Myotomal	Site of pain or main nerve bundle proximal to pain
Analgesic profile	Rapid onset <30 min after switch-on Rapid offset <30 mins after switch-off	Delayed onset >30 mins after switch-on Delayed offset >1 h after switch-off	Rapid onset <30 min after switch-on delayed offset 1h after switch-off
Duration of treatment	Continuously when in pain	~30 mins/session as muscle fatigue may occur	~15 mins/session as patients experience discomfort
Mechanism of analgesic action	Segmental	Extra-segmental Segmental	Peripheral Extra-segmental Segmental

bps: burst per second; pps: pulses per second

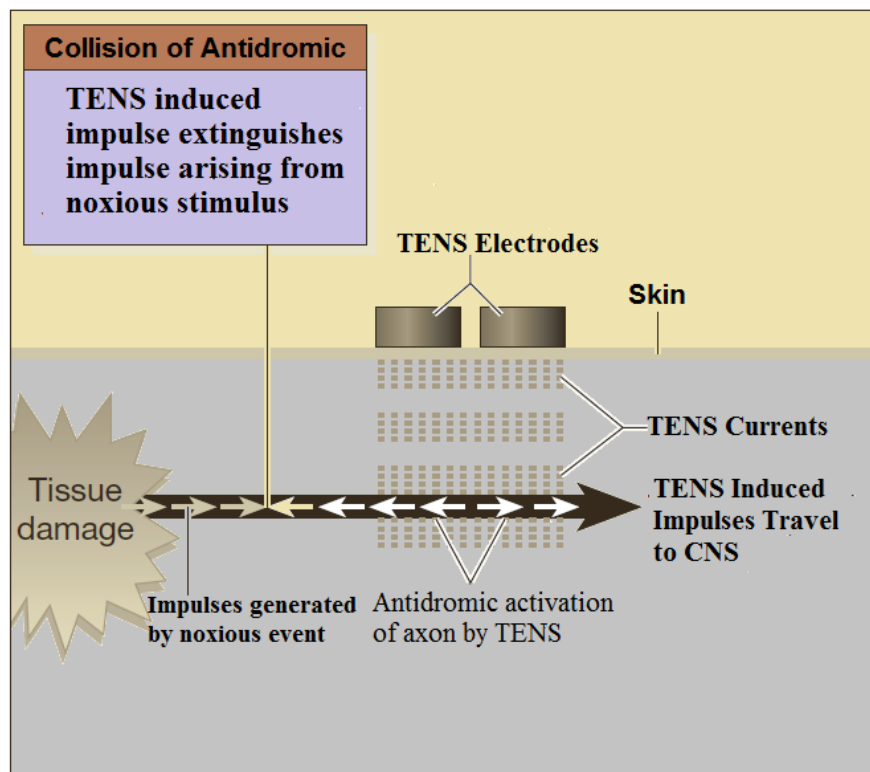
The output (electrical) characteristics identified for each TENS technique are based on the strength and duration of pulsed currents necessary to generate an action potential in different

types of axon. In clinical practice, patients and practitioners use the sensation produced by TENS to determine the appropriate stimulating characteristics.

### 2.3.6 Possible Mechanism Actions of TENS

TENS was originally justified on the basis of the gate theory, but different researches leads to a new understanding of the mechanisms activated by TENS stimulation. It now appears that conventional, acupuncture-like and intense modes activate different mechanisms of action. Several of the prevailing theories are touched upon here.

Stimulation-induced analgesia in TENS stimulation can be categorized according to the anatomical site of action into peripheral, segmental and extra-segmental [31]. In general, the main action of conventional TENS is segmental analgesia mediated by  $A\beta$  fibre activity. The main action of AL-TENS is extra-segmental analgesia mediated by ergo receptor activity. The main action of intense TENS is extra-segmental analgesia via activity in small diameter cutaneous afferents. Conventional and intense TENS are also likely to produce peripheral blockade of afferent information in the fibre type that they activate.



**Figure 2.12:** TENS-induced blockade of peripheral transmission. (Modified from Figure 17.11 in: [31])

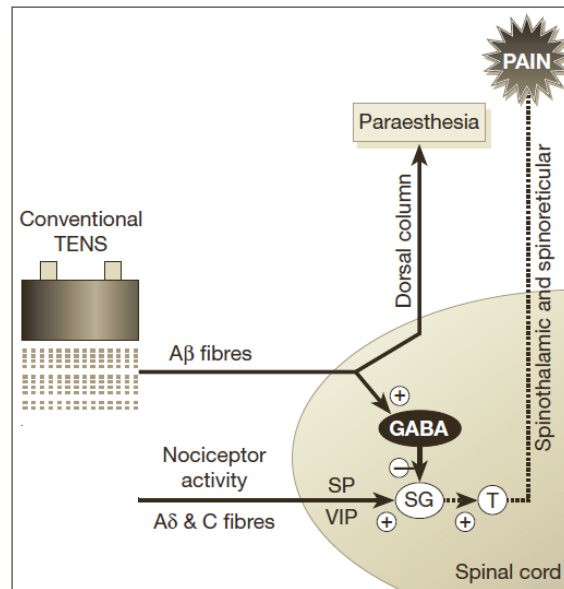
### 2.3.6.1 Peripheral Mechanisms [31]

The delivery of electrical currents over a nerve fibre will elicit nerve impulses that travel in both directions along the nerve axon, termed antidromic activation as shown on the (Figure-2.12) above. TENS-induced nerve impulses travelling away from the central nervous system will collide with and extinguish afferent impulses arising from tissue damage. Impulses generated by TENS will travel in both directions down an axon (antidromic activation) leading to a collision with noxious impulses travelling toward the central nervous system (CNS).

For conventional TENS, antidromic activation is likely to occur in large diameter fibres and as tissue damage may produce some activity in large diameter fibres conventional TENS may mediate some of its analgesia by peripheral blockade in large diameter fibres.

### 2.3.6.2 Segmental Mechanisms [31]

Conventional TENS produces analgesia predominantly by a segmental mechanism where by activity generated in A $\beta$  fibres inhibits ongoing activity in second-order nociceptive (pain related) neurons in the dorsal horn of the spinal cord as shown on the (Figure-2.13) below.



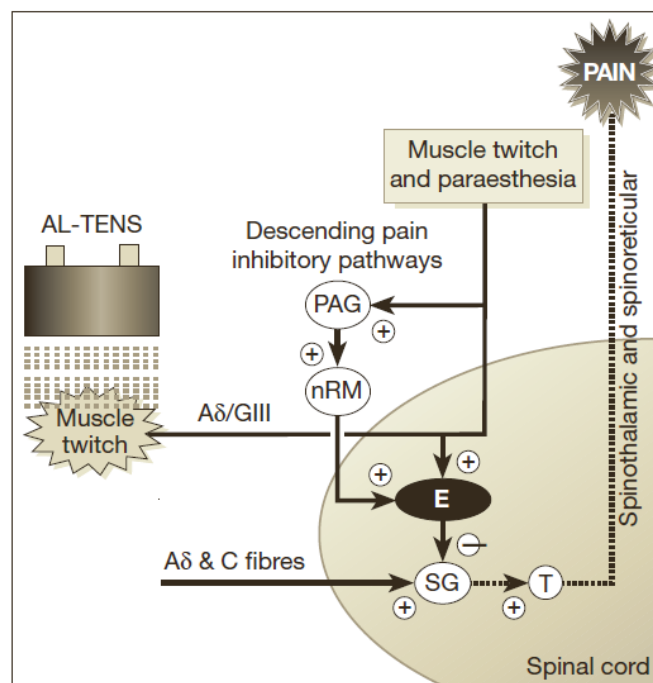
**Figure 2.13:** Neurophysiology of conventional TENS analgesia. (Modified from Figure 17.12 in: [31])

Activity in A $\delta$  and C fibres from nociceptors leads to excitation (+ve) of inter-neurons in the substantia gelatinosa (SG) of the spinal cord via neurotransmitters like substance P (SP, cutaneous nociceptors) or vasoactive intestinal peptide (VIP, visceral nociceptors). Central

nociceptor transmission neurons (T) project to the brain via spinothalamic and spinothalamic tracts to produce a sensory experience of pain. TENS-induced activity in  $A\beta$  afferents leads to the inhibition (-ve) of SG and T cells (dotted line) via the release of gamma amino butyric acid (GABA, black interneuron). Paraesthesia associated with TENS is generated by information travelling to the brain via the dorsal columns.

### 2.3.6.3 Extrasegmental Mechanisms [31]

TENS-induced activity in small diameter afferents has also been shown to produce extra-segmental analgesia through the activation of structures which form the descending pain-inhibitory pathways, such as peri aqueductal grey (PAG), nucleus raphemagnus and nucleus raphe giganto cellularis. Phasic muscle contractions produced during AL-TENS generates activity in small diameter muscle afferents (ergo receptors) leading to activation of the descending pain-inhibitory pathways as shown on the (Figure 2.14) below.



**Figure 2.14:** Neurophysiology of AL-TENS analgesia. (Modified from Figure 17.13 in: [31])

Activity in  $A\delta$  and C fibres from nociceptors leads to excitation(+ve) of central nociceptor transmission neurons (T) which project to the brain to produce a sensory experience of pain. TENS-induced activity in small diameter muscle afferents ( $A\delta$ , GIII) leads to the activation of brainstem nuclei such as the periaqueductal grey (PAG) and nucleus raphe magnus (nRM). These nuclei form the descending pain inhibitory pathways which excite inter-neurons which

inhibit (-ve) SG and T cells (dotted line) via the release of met-enkephalin (E, black interneuron). It is likely that paraesthesia and sensations related to the muscle twitch are relayed to the brain via the dorsal columns.

### 2.3.7 Clinical Efficacy

Section 2.3.5 explained regarding to clinical practice, and based on that and from the authors knowledge none of the three modalities of transcutaneous electrical nerve stimulation (TENS) are not still in practice for patients in Ethiopia [2, 3]. And from different researches on the literature, conventional TENS is most commonly used; AL-TENS and intense TENS are used only in specific situations. Despite a large published literature on TENS, there is no enough systematic experimental work that has directly compared the clinical effectiveness and analgesic profiles of these types of TENS. But to assessing TENS' effectiveness one needs to quickest methods of reviewing the clinical research on TENS is to read a recent systematic review. Systematic reviews involve the retrieval of relevant studies that have been selected according to certain inclusion criteria and using predefined criteria.

**Table 2.5:** Summary of Outcomes of TENS Systematic Reviews to Show Efficacy of TENS  
(modified from: TABLE 1. of [35])

Condition	Number of Studies	
	Included	Outcome
Chronic pain	19	Inconclusive
Chronic low back pain	5	No evidence to support TENS
Primary dysmenorrhoea	9	High frequency TENS more effective than placebo; low frequency TENS no more effective than placebo
Labor pain	10	TENS has no significant effect
Post-operative pain	17	In 15 of 17 RCTs, TENS had no benefit over placebo

Knee osteoarthritis	7	Conventional TENS and acupuncture-like TENS effective over placebo
Post-stroke shoulder pain	4	Inconclusive

TENS, transcutaneous electrical nerve stimulation; RCTs, randomized controlled trials, in general, TENS is used extensively in health care to manage painful conditions because it is safe and can be administered by patients themselves. Success with TENS depends on appropriate application and therefore patients and therapists need an understanding of the principles of application.

A systematic review of some literatures in this section shows that, the effectiveness of TENS in pain control management is more positive. However, better quality and patient based designs are required to enhance the effectiveness, and from the previous researchers have found that relevant electrical signal characteristics which must be examined in attempting to treat a painful sensation include the signal waveform, pulse repetition frequency, pulse duration, pulse amplitude and pulse modulation characteristics. Thus, from the above discussions know it's feasible and possible to proceed to the system design and implementation.

### **3. SYSTEM DESIGN AND IMPLEMENTATION**

In this chapter a description of the procedure to design and develop the proposed TENS system and required steps will be explained. A detailed description is made for the proposed system with three basic parts, which are: Architecture, Hardware system design phase, and Software system design phase as follows:

#### **3.1 Architecture**

Regarding to the architectural point of view, transcutaneous electrical stimulation systems must meet specific design requirements to supply pain suppressing impacts to help patients with the pain. To function as a take-home device, TENS device must be easily operable, be safe, portable, and comfortable and so that users can access the device without any help or with minimal assistance or aid.

In general, modern standard typical TENS devices consist of four main parts [6, 10, 35]:

- Data communication: To detect bidirectional data.
- Stimulating Unit: Provides electrical pulses to a certain nerve points. (Digital controller, a high voltage or current generation and switching circuitry, and battery).
- User Control Unit: To enables the stimulation features and change the output amplitude, frequency and duration settings for specific user requirements.
- Electrodes: Placed on pain area which is used to apply stimulus to the target patient.

In summary, by taking the main components of a typical TENS device as an input to the research, the proposed stimulator system has been designed including different pain relief levels that can encourage future expansion works.

#### **3.2 The Designed and Simulated Proposed System**

##### **3.2.1 Overview**

This section presents the hardware and software design decisions used to develop the stimulator subsystem. The section is divided down into two main parts: 1) decisions on Hardware Design Stage used for the system, 2) the overall software structure of the stimulator subsystem.

When deciding on the hardware platform for use in this stimulator system, applicable alternatives were compared and considered, and the final decision was based on the most suitable option. Finally, the overall Stimulation Algorithm of the stimulator subsystem is provided.

### **3.2.2 Hardware System Design Stage**

From the requirements analysis, two different hardware categories have been considered at the design stage, when deciding the most suitable option, these included: 1) microcontrollers (such as ARM (Advanced RISC (Reduced Instruction Set Computer) Machine), Atmel AVR (Advanced Virtual RISC) and PIC (Peripheral Interface Controller) microcontrollers); and 2) Field Programmable Gate Arrays (FPGAs) (such as Altera and Xilinx).

The decision process starts by deciding on using either a microcontroller based or FPGA based architecture. The design and simulation stage differ greatly depending on which of these two architectures is chosen. The structure of a microcontroller is comparable to a small computer placed in a single chip. This chip has all the necessary components found in a computer such as processor, memory, timers, and various I/O. They are used in almost all embedded devices which require to perform specific tasks and which connect to other devices or computers for communications. Overall microcontrollers are intended for use in low-power applications, making them well suited for devices with a battery source. In general microcontrollers are programmed using software.

The summary of the advantages and disadvantages of using a microcontroller based platform are:

#### **Advantages**

- Low power consumption
- Programming (ASM, C, C++)
- Future design flexibility
- Standardized device support

#### **Disadvantages**

- Unused functionality
- Initial design flexibility
- Lower performance

FPGAs are integrated circuit designed devices that are configured for specific task(s) by the designer, hence the term “field-programmable”. These integrated circuits can contain millions of logic gates which can be “connected” or configured to a desired specification. The nature of FPGA's allow them to be very flexible since you start off with arrays of gates, these can then be used to perform any logic function that can fit within the provided number of gates. In contrast, a microcontroller already has its own circuitry, instruction sets and protocols that have to be used in the design. FPGAs are programmed in hardware using a hardware description language (HDL). Overall the flexibility and performance of FPGAs comes at a cost as they usually consume more power and are more expensive than a typical microcontroller.

The summary of the advantages and disadvantages of using FPGAs based platform are:

### **Advantages**

- Higher performance
- Initial design flexibility
- Greater accuracy and timing
- Design for required functionality

### **Disadvantages**

- High power consumption
- Future design flexibility
- Higher cost
- Longer time to market

Comparing the two platforms described above specifically that of a microcontroller based system and an FPGA based system, the advantages and disadvantages when using one over the other has been summarized above. From the analysis, it is concluded that microcontroller based architectures provide a more standardized design approach using protocols, methods and building blocks (e.g., analog to digital converters (ADC), digital to analog converters (DAC), timers, universal asynchronous receiver transmitters (UART), etc.) that have been industry tested and proven in functionality and reliability. The very nature of microcontrollers allows the possibility for future design and simulation for additional support and features without necessarily re-designing the entire system. In addition, most microcontrollers provide integrated

power saving modes that allow the system to be placed in idle or sleep thus lowering power consumption compared to constant power utilization under a full operational mode.

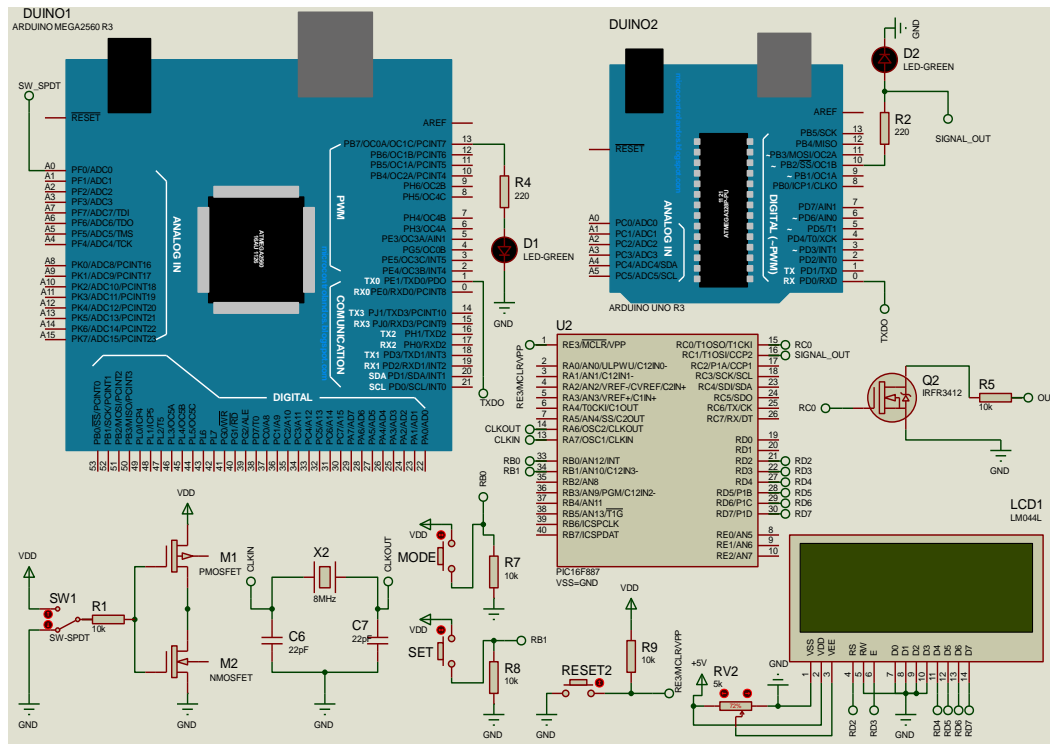
On the other hand, an FPGA based system in general allows for higher performance which is best suited for complex algorithms or digital signal processing (DSP) calculations where results must appear within short windows of time. Furthermore, designs using this type of platform allow for maximum initial design flexibility, allowing one to design and implement only the required and exact functionality. When using a microcontroller, the most suited device for an application is chosen but in most cases there are always features and functionality that are included but never used or required. After considering the advantages and disadvantages of both hardware platforms for use in the subsystem design and implementation, the microcontroller architecture (PIC microcontroller architecture, which is one of frequently found in the portable device industry) were selected as the best choice for this research work. The main deciding factors favoring microcontroller architecture were: a) lower power consumption with greater power control and usage options making it ideal for use in a portable system powered by batteries, b) ability to be more flexible for future design changes and feature support, c) inclusion of industry standard communication blocks, and d) its lower cost with shorter time to market advantage.

The second decision process finalize by deciding which wireless communication is suited for the design and simulation of the proposed stimulator and which is best chosen comparatively. Though, looking on a wireless communication between two microcontrollers, options like Xbee or Bluetooth were going to cost too much compare to RF transmitter and receiver. So, since RF transmitter and receiver are cheap and pretty easy to use. Taking into consideration the above points, the proposed system is working with RF 433MHz transmitter and receiver, and used for ideal application of a system with remote control and low power consumption.

By taking all the discussions above in to consideration the proposed TENS stimulator has been designed and simulated, the overall design stage of the proposed stimulator consists of a microcontroller, keypad as an input, electrodes, and wireless system. So, in the following section detail information about the design of the proposed wireless TENS stimulator will be discussed. And also hardware, and software algorithm and also circuit diagram of the proposed wireless TENS stimulator will be described in details.

### 3.2.2.1 The Circuit Diagram of the Designed and Simulated TENS System

The circuit diagram of the proposed stimulator system consists of several components as shown in Figure 3.1, the principle operation of the proposed system and description of each component is given in details in the following section.



**Figure 3.1:** Circuit diagram of the proposed TENS device

The proposed stimulator system (Figure 3.1) mainly consists of three type of microcontroller. The first microcontroller is PIC16F887 (40-pin) which is the main controller and has a low-power consumption and it is specified as nano-Watt technology chip. The remaining microcontrollers are Arduino Mega 2560 and Arduino Uno 328 microcontroller with RF 433MHz transmitter/receiver module, this is the wireless unit of the system which is easily connect on a computer with a USB cable and it simply power it with a battery or AC-to-DC adapter to get started also.

The MC34063 type DC to DC (converter chip) voltage regulator is used to design a circuitry to control the amplitude of the designed system in a range of 1V DC to 35V DC level. This voltage is used at the source input of a power MOSFET switch. The switch is controlled by microcontroller.

Pulses at the required frequency and pulse-width are generated by the microcontroller and these pulses are used to switch the MOSFET ON and OFF. The Drain output of MOSFET drives a pair of electrodes connected to the patient. The wireless part of the system working with two RF 433MHz transmitter/receiver module, they are connected on the two arduino. During the stimulation these modules used RF technology for communication between the arduinos.

The Arduino Mega 2560 microcontroller is transmitter side of the communication unit, which sense the sending signal by the subject bodies and transmits this signal to the second arduino, and Arduino Uno 328 microcontroller which is the receiver side of the communication unit, which receive the transmitted signal and give it to the main controller, then the main microcontroller PIC16F887 sense the signal coming from the receiver side and starts the stimulation.

A liquid crystal display is used to provide and display control over stimulation of modes and parameters. Preferably, two push button switches named SET and MODE is used to configure the operational parameters, such as the pulse-width, operation stages, and the frequency.

In sum, the thesis provides a transcutaneous electrical tissue stimulator which can be used by hand of patients, and it is a remotely controlled system which overcomes a wire complexity. And to the author's knowledge, it is new prospect and experience for country like Ethiopia.

The designed stimulator system includes an electrical stimulation generator which consists of main PIC microcontroller that is a programming unit for controlling the electrical stimulation which helps to regulate the operation through a plurality of different modes, each being intended to administer treatment via a specific Waveform available and a remote control unit which is basically important to make the electrical stimulation generator unit ON and OFF, both sections are connected through a wireless communication unit. The electrical stimulation generator unit includes output terminals for delivery of electrical stimulator to electrodes, main program for use in determining its mode of operation and a power source for the circuitry two pushbutton switches named SET and MODE, and are used to configure the operational parameters, such as the pulse-width, operation profile , and the frequency. In this proposed system, eight levels of frequency, six levels of pulse-width, and four selectable stages are available.

According to one aspect of the research, the remote controlling unit includes a plurality of a keypad analog controls and indicator lights to provide control over electrical stimulation generator unit. According to still another aspect of the research, the electrical stimulation generator includes liquid crystal display, which allows the operator to verify the modes and parameters. Further, the designed system is capable of delivering a variety of Waveforms to patient tissue, with varying amplitude according to the patient's comfort level, so as to be capable of treating a variety of physical conditions both acute and chronic.

### 3.2.2.2 The Designed and Simulated Remote Control Unit

Schematic for the transmitter Side:

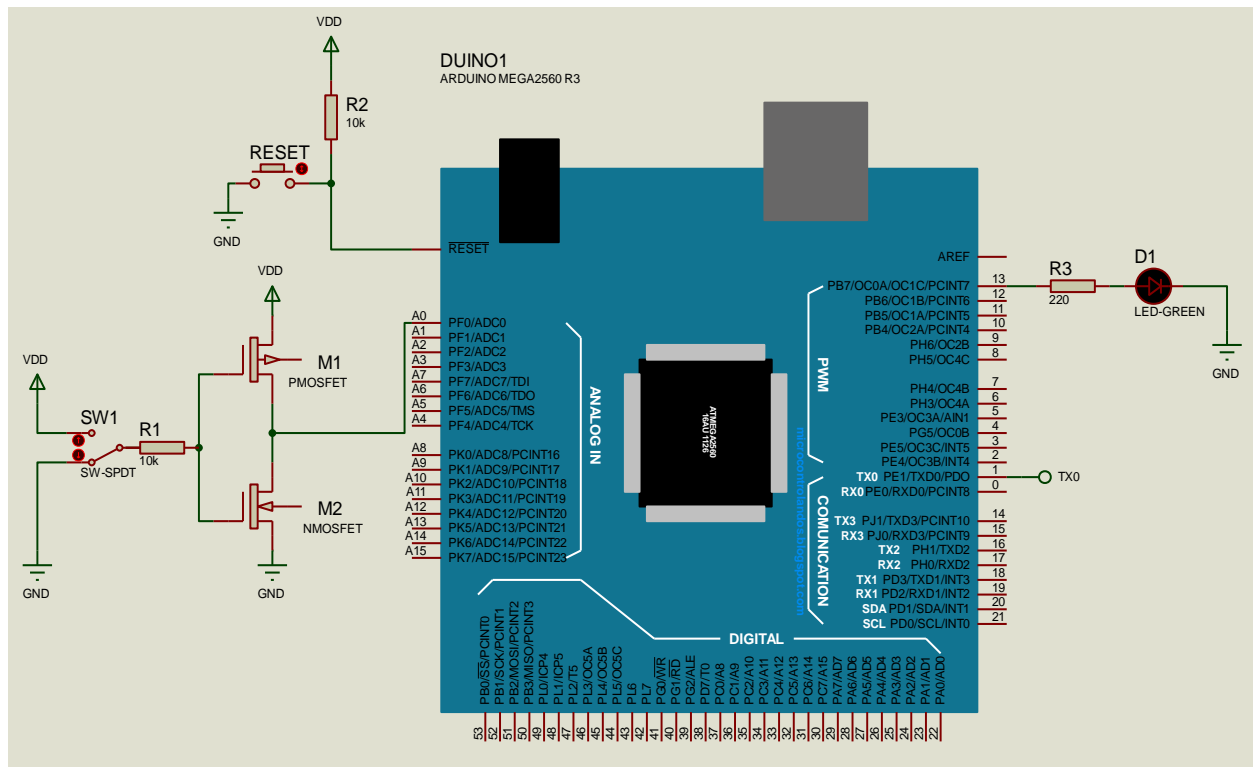


Figure 3.2: Schematic for the transmitter side

#### How This Part Works?

The designed TENS system is first actuated by the patient using keypad switch button, which is used as an interfacing input to CMOS logic circuit and this logic circuit draws about 0.4mA for logic low and sources approximately 2.0 to 5.5 V for logic high input.

Then this analog output signal is directly drawn to the transmitted side microcontroller (ATmega2560) and enter to analog input pin ‘PF0/ADC0’ of controller and then converted it into digital signals by using A/D converter, which is built in inside ATmega2560 microcontroller.

Now this digital signal is forward to transmitter RF-433MHz, where data pin receives the data signal and modulate it. Further transmitter transmits data signal through the antenna.

### 3.2.2.3 The Designed and Simulated Electrical Stimulation Generator Unit

#### Schematic for the Receiver Side

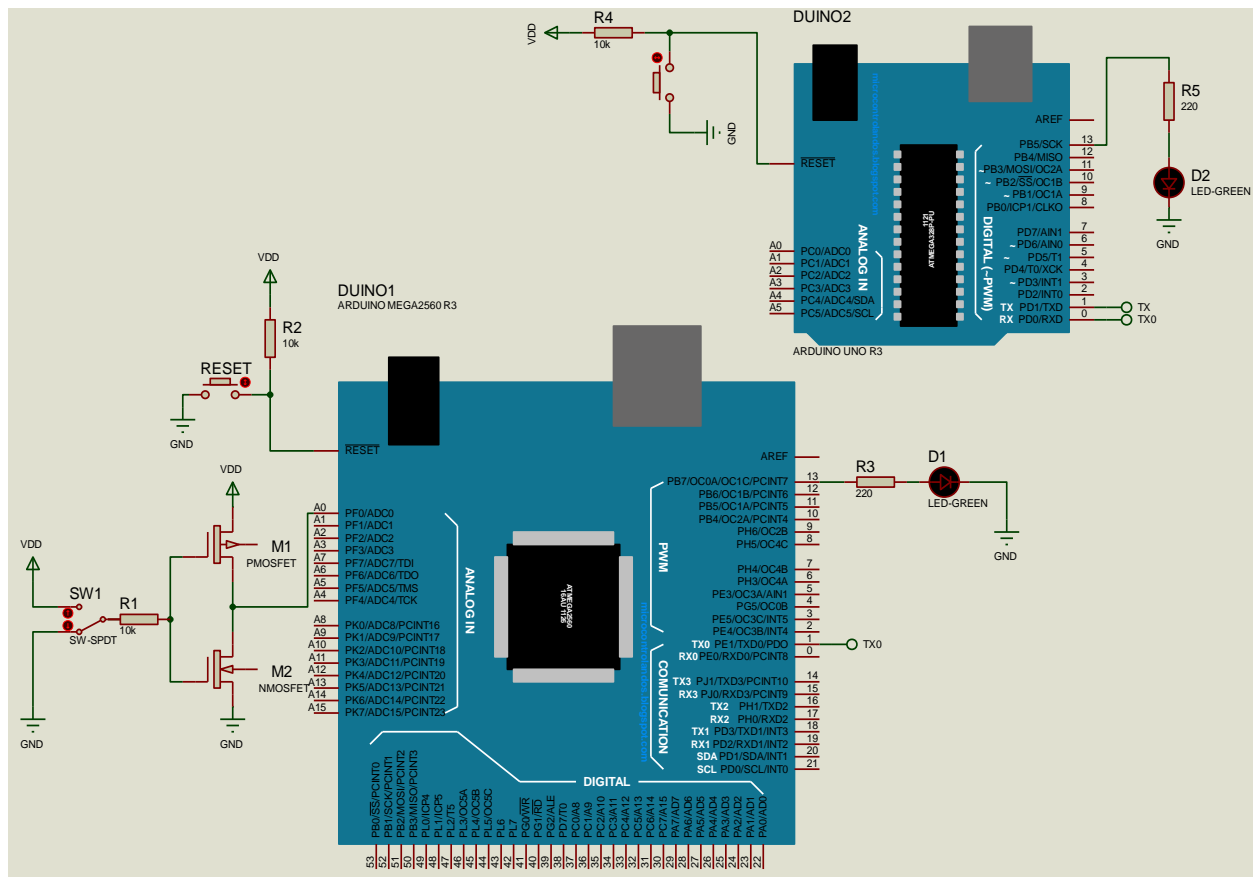


Figure 3.3: Schematic from the transmitter to receiver side

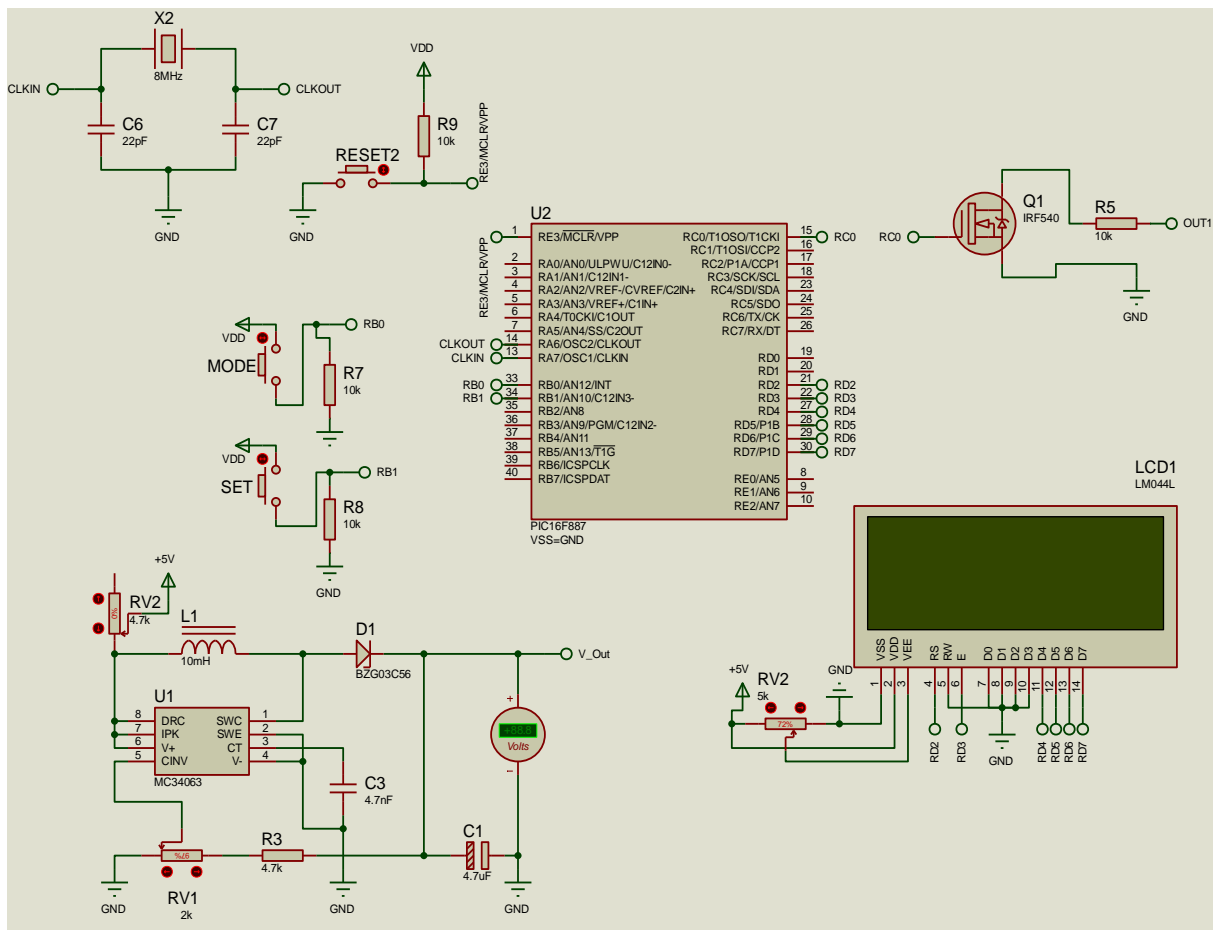
#### How This Part Works?

The receiver RF-433MHz receives the RF modulated digital signal from the transmitter side. Receiver further forward data to Arduino UNO board via pin number Pin ‘PD0/RXD’. Then the microcontroller ATmega328 fixed on the Arduino UNO board process the received digital signal.

After that the processed signal flows on the digital output pin of arduino Uno ATmega328 ‘PD1/TXD’ which is directly connected to the interrupt input pin ‘RC1/T1OSI/CCP2’ of the microcontroller PIC16F887 through a resistor.

Most programs use interrupts in their regular execution. The purpose of the microcontroller is mainly to respond to changes in its surrounding. In other words, when an event takes place, the microcontroller executes the program inside it.

### Schematic for the Main PIC16F887 Microcontroller:



**Figure 3.4:** Schematic for the main PIC16F887 microcontroller

The received signals are then demodulated and passed to PIC16F887 microcontroller through the interrupt input pin ‘RC1/T1OSI/CCP2’ of the microcontroller through a resistor for interpretation and storage therein. This PIC16F887 microcontroller is responsive to the interfaced signal by the receiver side controller, delivering to the switching circuit of output stage circuitry that is connected to the final electrode.

Two pushbutton switches named SET and MODE are connected to port inputs 'RB1/AN10/C12IN3-' and 'RB0/AN12/INT' respectively, and are used to configure the operational parameters, such as the pulse-width, operation profile, and the frequency. The LCD can remove during the normal process and it is only used for configuration which is connected to PORTD of the PIC16F887 microcontroller.

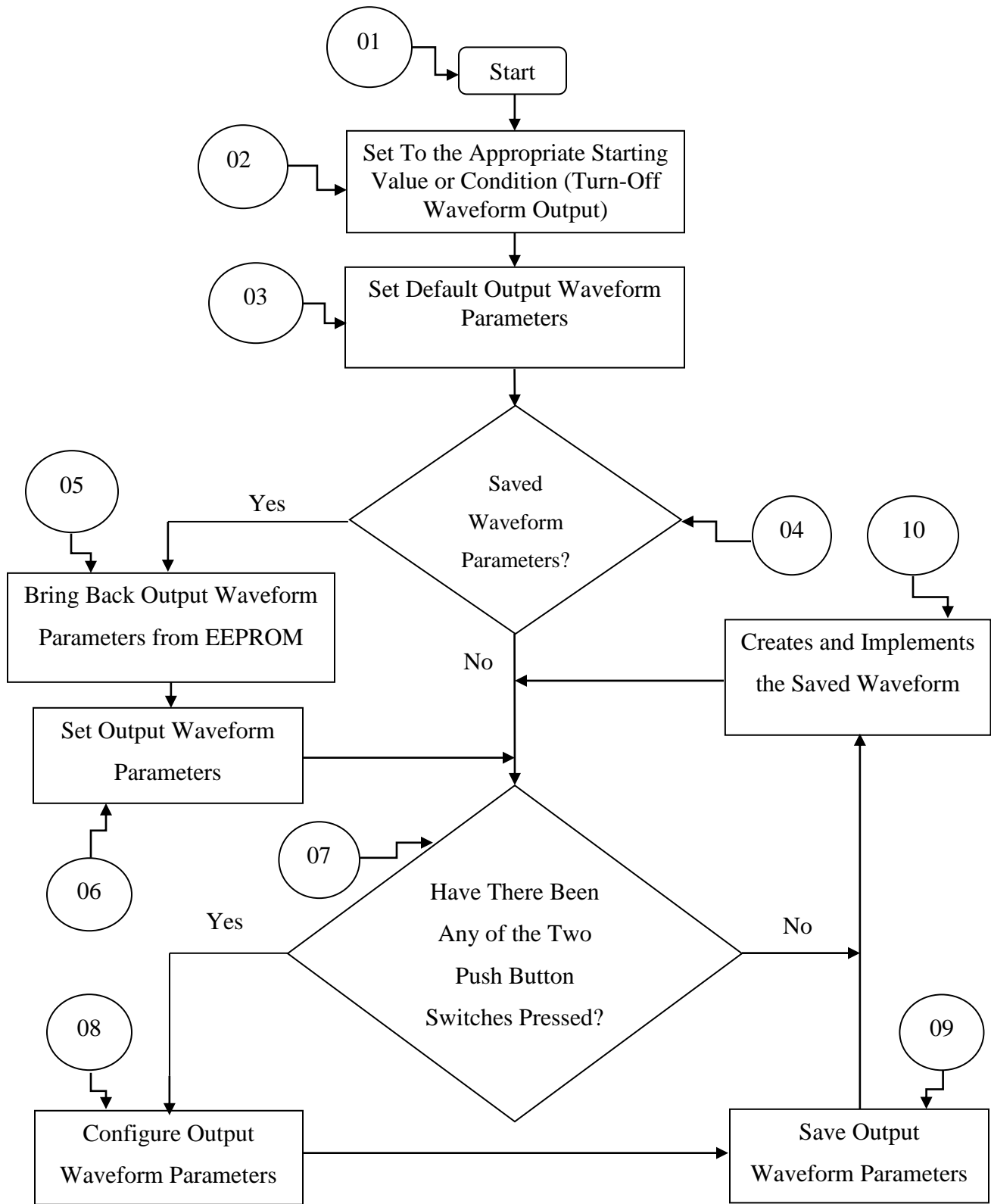
The MC34063 type DC to DC (converter chip) voltage regulator is used to design a circuitry to control the amplitude of the designed system in a range of 1V DC to 35V DC level. This voltage is used at the source input of a power MOSFET switch. The switch is controlled by microcontroller. 'RC0/T1OSO/T1CKI' output pin of the microcontroller is used to turn ON and OFF the output voltage through IRF540 type high voltage MOSFET switch. It is possible to remove the configuration switches and the LCD, and for example connect the device to a PC for configuration.

The particular mode of stimulation selected via programmer or subjected bodies, that is the patient programs or controls the modes of operation, while monitoring generator mode from display and the physical sensations so that maximum tissue stimulation efficacy results.

### **3.2.3 Software Design Stage**

The proposed stimulator system consists of two software program, first program for main stimulation circuit unit to supply required stimulus signal second program for wireless communication unit to transmit incoming signal from keypad push button, which is actuated by the subject body to the stimulator by using the transmitter and receiver parts.

The first software of the designed and simulated system has designed using the mikro C PRO for PIC language. This is popular high-level C programming language for microcontrollers, developed by mikro Elektronika. The second software of the wireless unit has been designed on arduino Uno and arduino Mega boards using arduino programming language software. The Arduino programming language is a simplified version of C/C++.



**Figure 3.5:** Software flow diagram for the overall operation of the proposed TENS stimulator.

In block '01' the unit is activated by turning the keypad switch button to the on position. In block '02' the unit turns off the waveform output to the patient.

In block '03' the unit sets the default wave forms. The default waveforms are used if the unit has never been turned on or if previously saved waveforms do not fall within a predetermined range. The purpose of the default waveforms is to insure that the user will not receive a strong signal immediately upon activation of the proposed unit.

In block '04' the unit determines if waveforms have been saved. 'Saved' waveforms are the waveforms that the patient was using when the unit was last turned off. If the waveforms have been saved, then the unit proceeds to block '05' which retrieves the waveforms and to block '06' which sets the output waveform parameters.

The unit then proceeds to block '07' which determines if any of the setup keys have been depressed. If not, then the unit proceeds to block '10' and creates and implements the saved waveform. If it is determined in block '04' that no waveforms have been saved or if 'saved' waveforms are not within a required range, then the unit proceeds directly to block '07' with the default waveforms. If no buttons have been pressed, then the default waveforms are initialized in block '10'.

If push switch buttons have been pressed then the stimulator proceeds to the next block, which changes the output wave form accordingly. That is patient's enables to configure and control the intensity and also to adjust the output amplitude, frequency, duration and the user profile settings for specific parameters.

If push switch buttons have been pressed, then the unit proceeds to block '08' which changes the output wave form accordingly. That is patients can enable to configure and control the intensity, on-off switch and also to adjust the output amplitude, frequency, duration and the user profile settings for specific parameters.

The two push button switches are, MODE and SET used to adjust these requirements. While operating the configuration is made by pressing the MODE switch while turning the power ON. The frequency and pulse duration can be adjusted respectively. The output waveform then saved in block '09' and after that, the unit proceeds to block '10' to initialize the new output waveform.

## 4. RESULTS AND DISCUSSION

### 4.1 Results

In this thesis, the simulation results of the designed system were carried out to assess its performance. Eight levels of frequency, six levels of pulse-width, and four selectable stages has used as the designed parameters/specifications, which could have a number of possibilities for different degree of simulation.

The designed system was tested on ISIS PROTEUS DESIGN SUIT software, and for the programming parts of the design, mikro C PRO software for PIC language which is a popular high-level C programming language, and Arduino Programming Language Software which is a simplified version of C/C++ has been customized.

In summary, the designed stimulator system has the following design parameters/specifications:

Frequencies that could be selected:

10Hz, 20Hz, 30Hz, 40Hz, 60Hz, 80Hz, 100Hz, 200Hz.

Pulse-width that could be selected:

150 $\mu$ s, 200  $\mu$ s, 250  $\mu$ s, 500  $\mu$ s, 750  $\mu$ s, 1000  $\mu$ s.

Stages that could be selected:

Stage 1, 2, 3, 4.

Four (4) selectable and configurable stages have been described with different timing requirements that may be suitable for different users. These stages timing selections are shown below in the table. Upon activation, preferred treatment program will automatically proceed through four stages, over a total period of forty minutes, forty seconds. Note that during the configuration the frequency, pulse-width, and stages can be selected by the users depending on the comfortable level of the pain management.

**Table 4.1:** The selectable and configurable stages with different timing requirements for the proposed stimulator system.

	<b>Ramp Down</b>	<b>Ramp Up</b>	<b>Fixed-Time</b>
<b>Stage-1</b>	12 seconds	12 seconds	5 minutes (300sec)
<b>Stage-2</b>	4 seconds	4 seconds	15 minutes(900sec)
<b>Stage-3</b>	12 seconds	12 seconds	5 minutes(300sec)
<b>Stage-4</b>	4 seconds	4 seconds	10 minutes(600sec)

Ramp\_Down: Specifies the time that the ending pulse should be extended

Ramp\_Up: Specifies the time that the initial pulse should be extended

Fixed\_Time: Total fixed time that the pulse is applied

**Table 4.2:** The designed and simulated wireless based TENS stimulator system

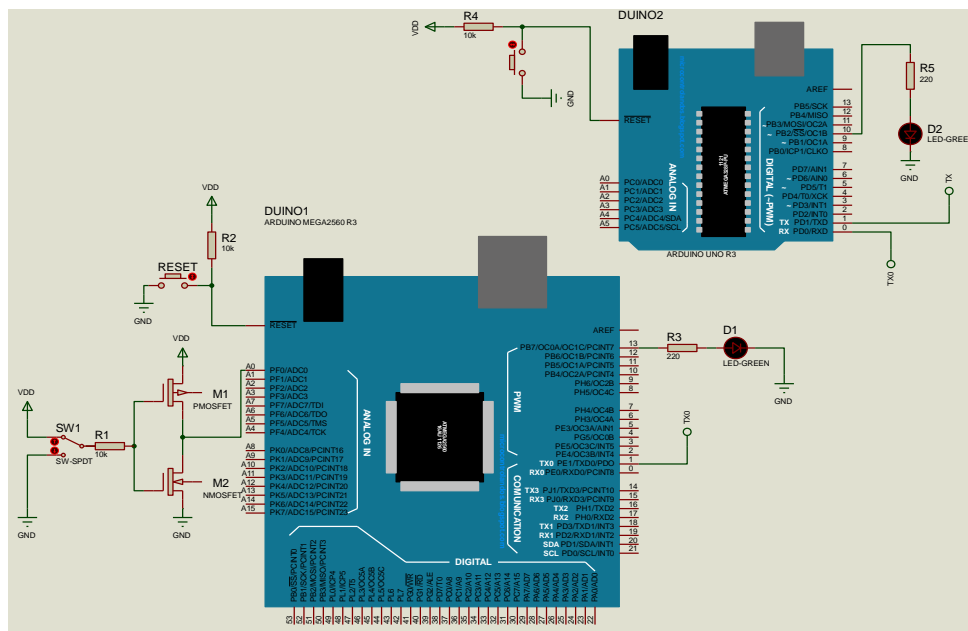
	<b>Amplitude</b>	<b>Pulse-width</b>	<b>Frequency</b>	<b>Stage</b>
<b>The Designed and Simulated Wireless Based TENS for Pain Control</b>	1-35 Volt	150 $\mu$ s, 200 $\mu$ s, 250 $\mu$ s, 500 $\mu$ s, 750 $\mu$ s, 1000 $\mu$ s	10Hz, 20Hz, 30Hz, 40Hz, 60Hz, 80Hz, 100Hz, 200Hz	Stage-1 up to Stage-4

#### 4.1.1 Simulation Results

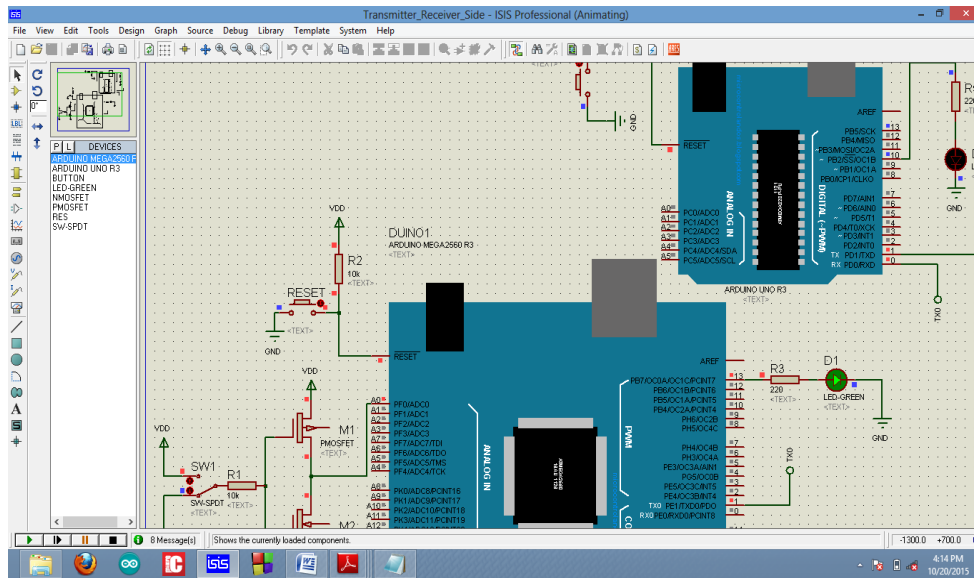
This section shows the final results of the software prototype during simulation process:

Figure 4.1 shows schematic for the transmitter and receiver parts of the designed system on the simulation software for software prototyping, and Figure 4.2 shows that simulation output when the subject making OFF the keypad switch button. Hence, from the first simulation result of Figure 4.2 it may be seen that when the designed stimulator system is inactive the LED has been given a green light on the transmitter section, which shows that the keypad switch button was not actuated by the subject body or the switch were at OFF position.

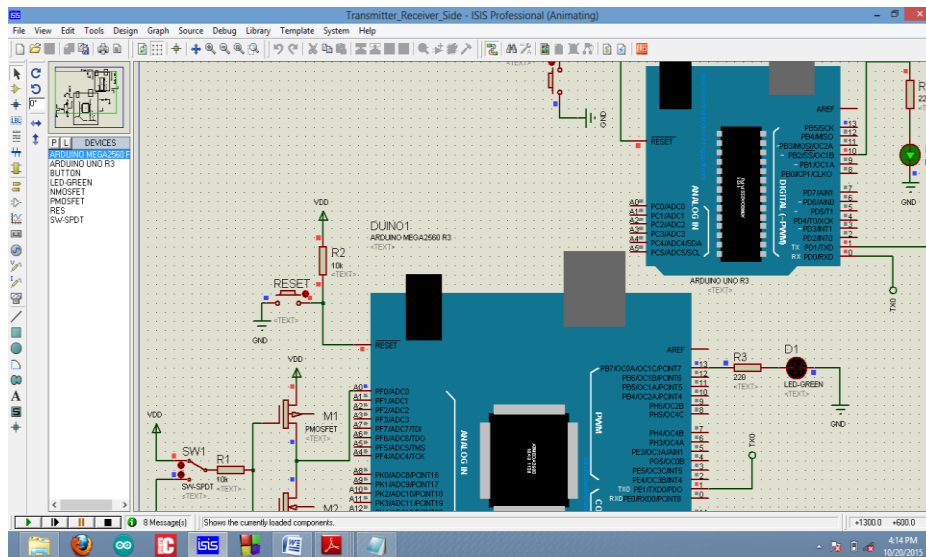
When the designed TENS system were first actuated by the patient using keypad switch button as shown from the simulation result of figure 4.3, the receiver section LED lights up and give green light which represents the transmitted signal were reach to the receiver section. During making ON the transmitter section, the analog output signal from the CMOS logic circuit were directly draw to the transmitted side microcontroller (ATmega2560) and enter to analog input pin of the microcontroller and then converted it into digital signals by using A/D converter, which is built in inside ATmega2560 microcontroller. Now this digital signal is forward to transmitter RF-433MHz, where data pin receives the data signal and modulate it, and further transmitter transmit data signal through the antenna.



**Figure 4.1:** Schematic for the transmitter and receiver parts of the designed and simulated system

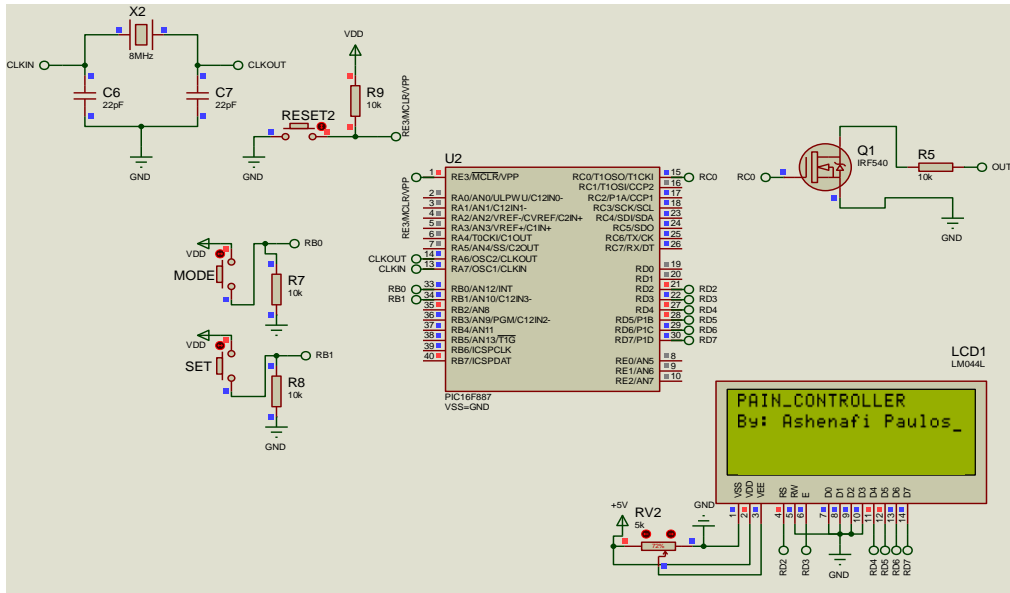


**Figure 4.2:** The simulation output when the subject making OFF the keypad switch button



**Figure 4.3:** The simulation output when the subject making ON the keypad switch button

As indicated above from figure 4.3, the LED lights up and give green light which shows the receiver RF-433MHz receives the RF modulated digital signal from the transmitter side. Thus, at the receiver section, the receiver further forward data to Arduino UNO board via pin number Pin PD0/RXD. Then the microcontroller ATmega328 fixed on the Arduino UNO board process the received digital signal. After that the processed signal flows on the digital output pin of arduino Uno ATmega328 PD1/TXD which is directly connected to the interrupt input pin RC1/T10SI/CCP2 of the microcontroller PIC16F887 through a resistor.

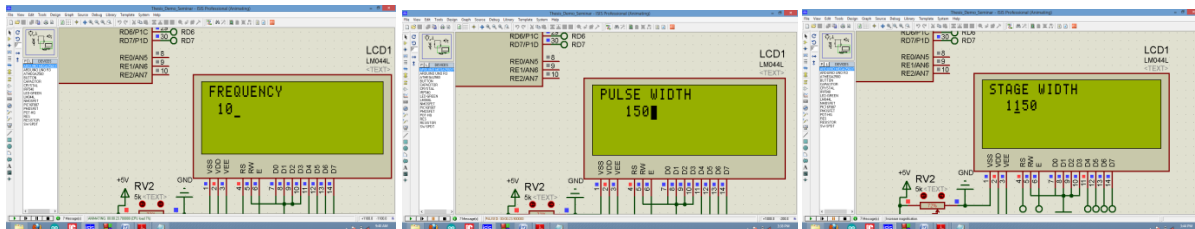


**Figure 4.4:** The main controller part with the start up display before it start the stimulation

As shown from Figure 4.4, the received signals are then demodulated and passed to PIC16F887 microcontroller through the interrupt input pin RC1/T1OSI/CCP2 of the microcontroller through a resistor for interpretation and storage therein. This PIC16F887 microcontroller at this stage of the system design is responsive to the interfaced signal by the receiver side controller, delivering to the switching circuit of output stage circuitry that is connected to the final electrode.

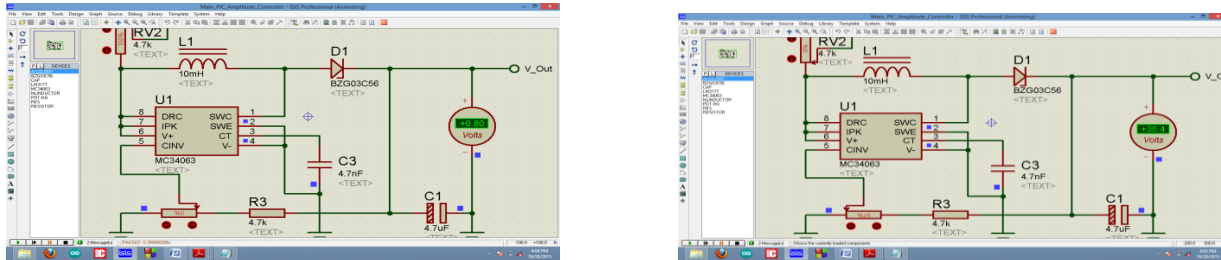
Two pushbutton switches as shown in Figure 4.4, named SET and MODE buttons has connected to port inputs RB1/AN10/C12IN3 and RB0/AN12/INT respectively. The pushbutton switches have used to configure the operational parameters, such as the pulse-width, operation profile, and the frequency.

As it may be seen, Figure 4.5 reveals the screenshots of frequencies, pulse widths, and stage of the designed stimulator system based on the simulation result, which was for a single case that could be selected by the subject body or the patient.



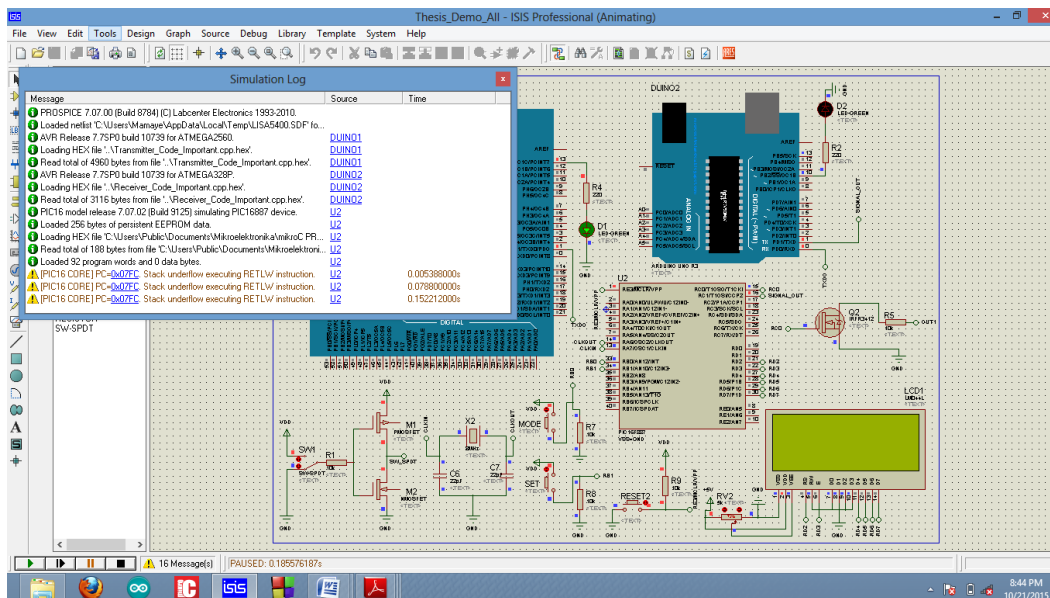
**Figure 4.5:** The screenshots of frequencies, pulse widths, stage for a single case that can be selected by the subject

According to Figure 4.6, the simulation results of the designed system amplitude that ranges from 1V to 35V (shows the minimum and maximum voltage of the system) has revealed. MC34063 type DC to DC (converter chip) voltage regulator has used to design a circuitry to control the amplitude in a given range of DC voltage level.



**Figure 4.6:** The screenshots of the amplitudes ranges from 1V to 35V (shows the minimum and maximum voltage of the system)

From Figure 4.7 of the simulation result, it can be understood that stack under flow RELTW instruction" problem was generated, this is because of hardware call stack of PIC16F887 microcontroller, which is used to save return addresses and was not software-accessible. Hence, the full code of the main program for the thesis has had a return syntax code inside it, in the process of simulating the designed system with the full programming code of the HEX file; hardware call stack problem was generated.



**Figure 4.7:** The overall schematics of designed and proposed system with a stack underflow problem for the full programming code.

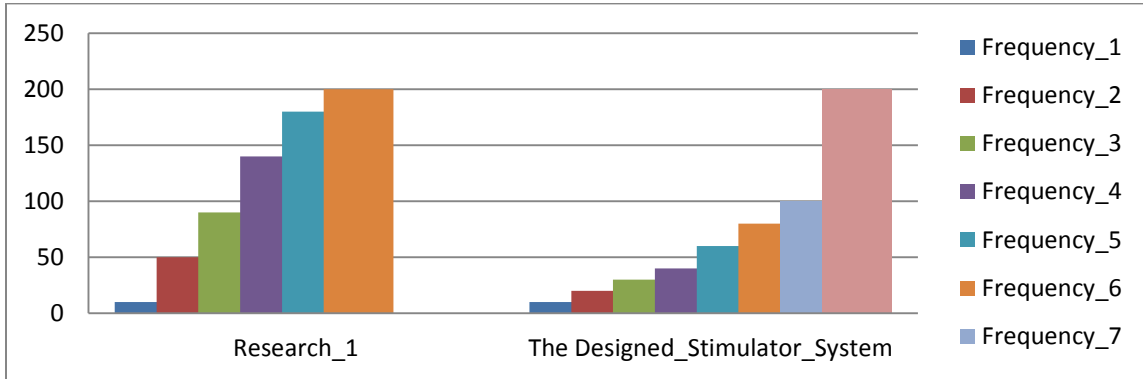
### **4.1.2 Validation of the Simulation Results**

There are ongoing researches regarding to the effectiveness and mechanisms of action of specific TENS characteristics. In this thesis, recently conducted four researches has been taken as a baseline to validate the final results of the proposed system workability, and to making sure that the final results are at the required and accepted level of effectiveness and inclusiveness of all mechanisms of action of TENS characteristics [4-7]. All the researches provides concrete information's regarding to the effective responses of TENS system for different types of TENS techniques (Conventional, Acupuncture, and Intense TENS).

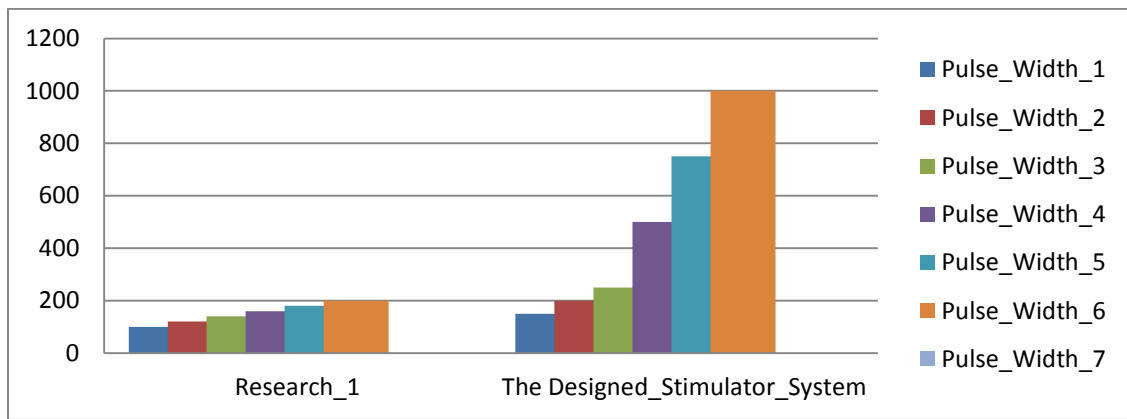
Along this lines, by taking parameters like frequency (measured in Hz or pulses per second) and pulse width (measured in  $\mu$ s) from the baselined research for the different types of TENS techniques, the validation of the simulation results has been discussed below.

Note that, to discuss the validation of the simulation results the thesis only consider graphs of the first baselined research from Figure 4.8 up to Figure 4.13 for all types of mechanisms of actions of TENS techniques, because the rest baselined researches are similar in their ways of expansions and easy to understand in a similar way. The discussion here below is only taking to reveals that the final simulation results of the thesis are valid and at the accepted and required clinical therapy.

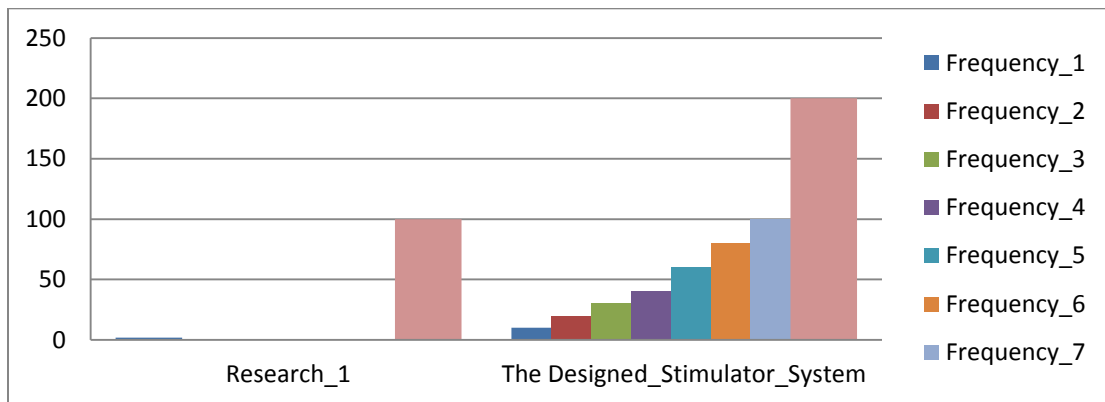
In a way of comparing different results, the following graphs show the workability of final results and the simulations results are at the accepted and required level in reference to the baselined researches [4-7].



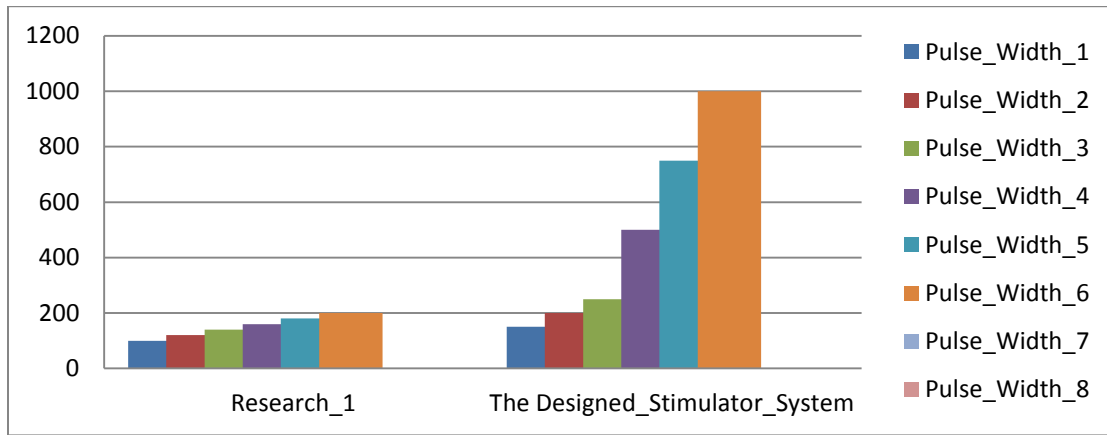
**Figure 4.8:** Frequency (Hz) Comparisons for *the Designed\_Stimulator\_System* in Opposition to *Research\_1[4]* for Conventional TENS



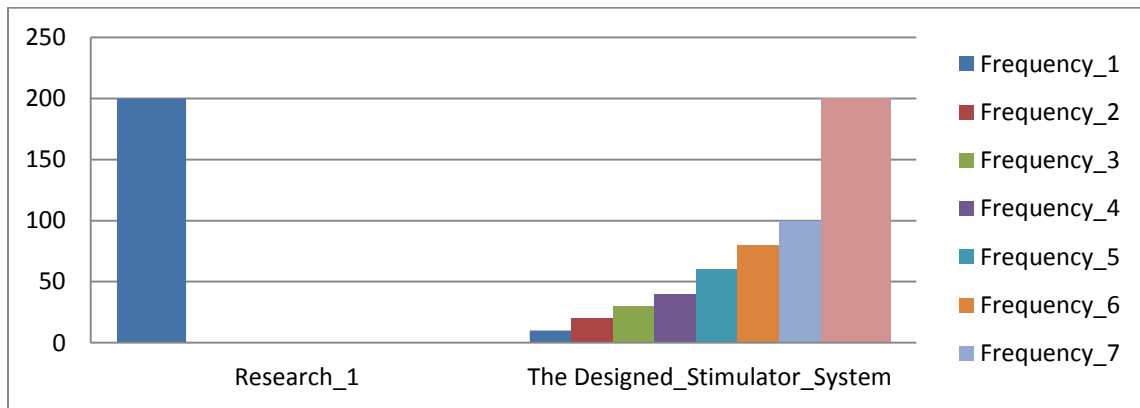
**Figure 4. 9:** Pulse\_Width (µs) Comparisons for *the Designed\_Stimulator\_System* in Opposition to *Research\_1[4]* for Conventional TENS



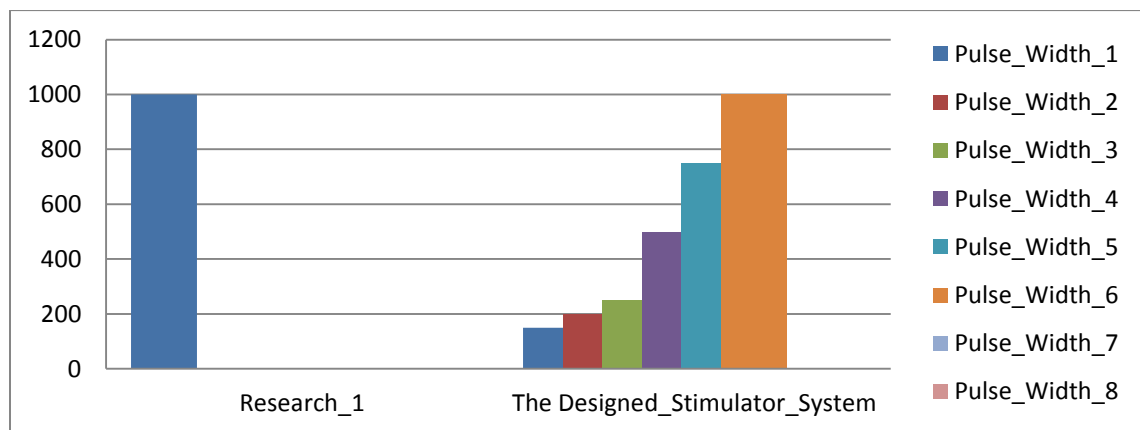
**Figure 4.10:** Frequency (Hz) Comparisons for *the Designed\_Stimulator\_System* in Opposition to *Research\_1[4]* for Acupuncture TENS



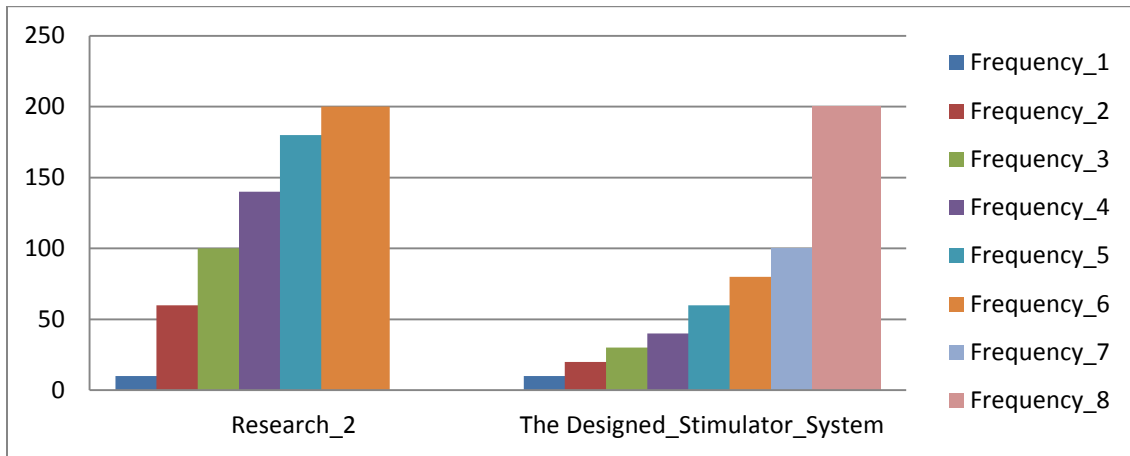
**Figure 4.11:** Pulse\_Width ( $\mu\text{s}$ ) Comparisons for *the Designed\_Stimulator\_System* in Opposition to *Research\_1[4]* for *Acupuncture TENS*



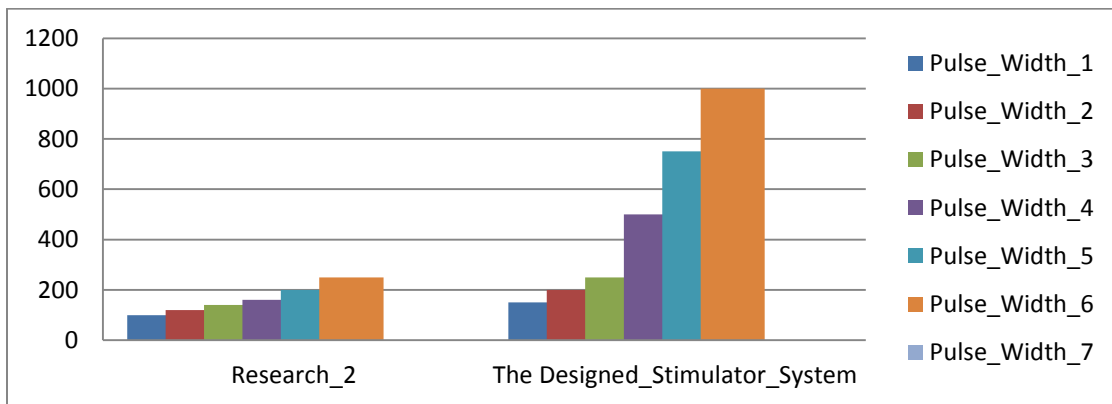
**Figure 4.12:** Frequency (Hz) Comparisons for *the Designed\_Stimulator\_System* in Opposition to *Research\_1[4]* for *Intense TENS*



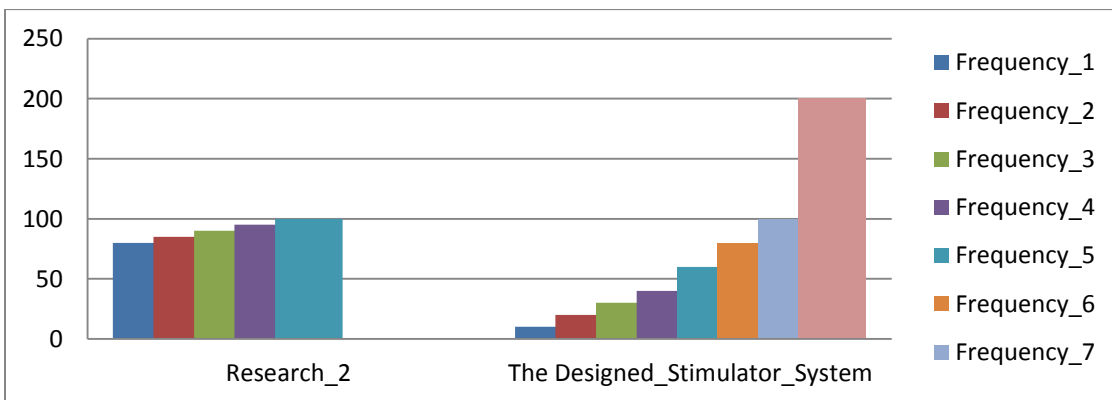
**Figure 4.13:** Pulse\_Width ( $\mu\text{s}$ ) Comparisons for *the Designed\_Stimulator\_System* in Opposition to *Research\_1[4]* for *Intense TENS*



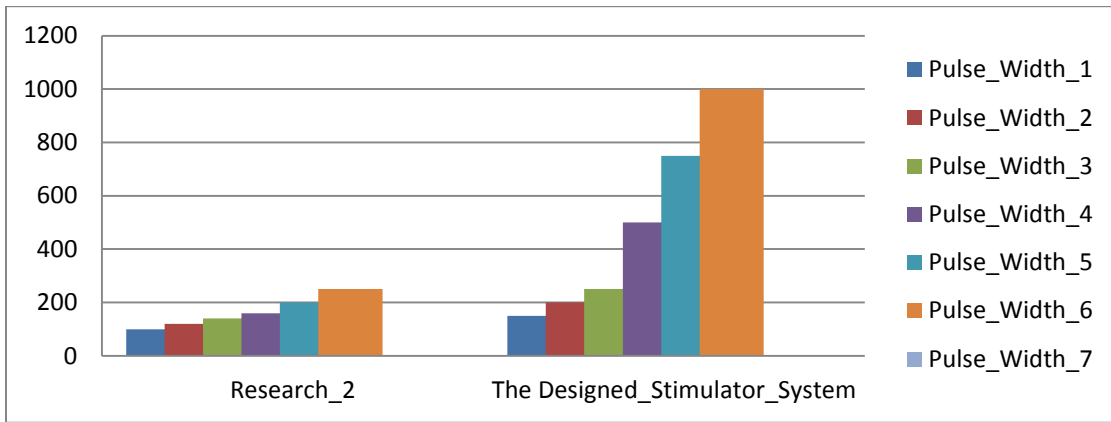
**Figure 4.14:** Frequency (Hz) Comparisons for *the Designed\_Stimulator\_System* in Opposition to *Research\_2[5]* for *Conventional TENS*



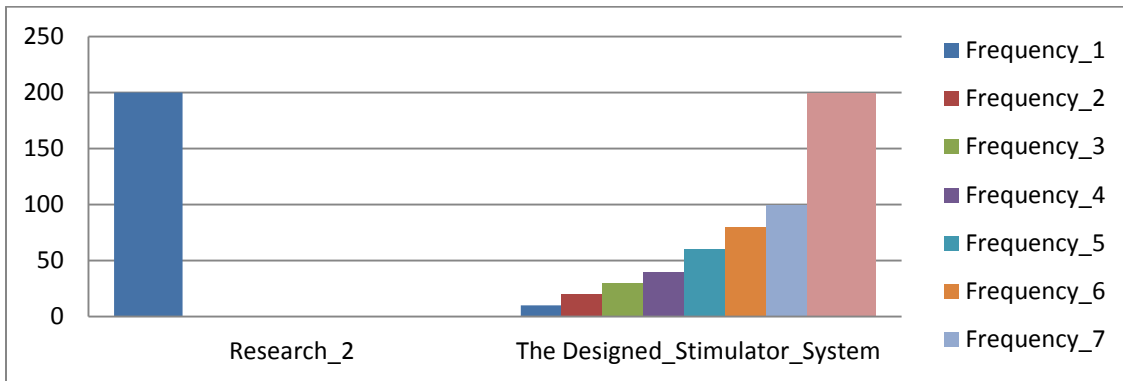
**Figure 4.15:** Pulse\_Width ( $\mu$ s) Comparisons for *the Designed\_Stimulator\_System* in Opposition to *Research\_2[5]* for *Conventional TENS*



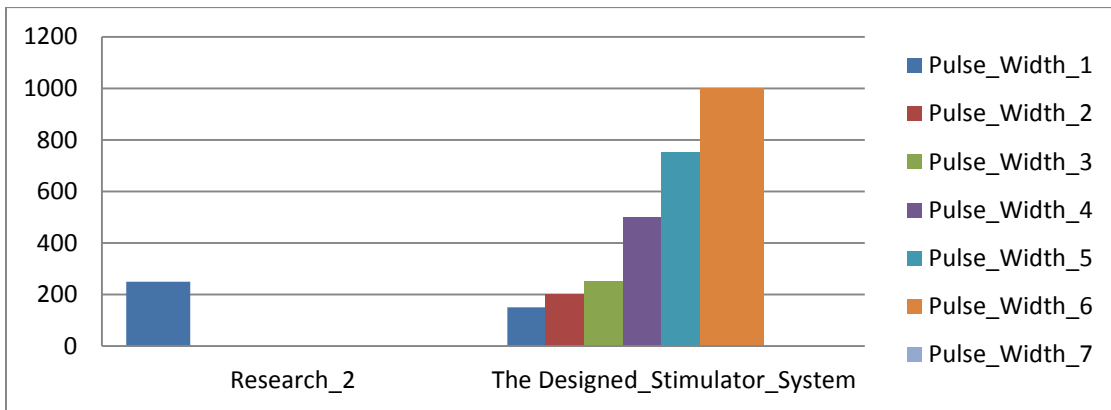
**Figure 4.16:** Frequency (Hz) Comparisons for *the Designed\_Stimulator\_System* in Opposition to *Research\_2[5]* for *Acupuncture TENS*



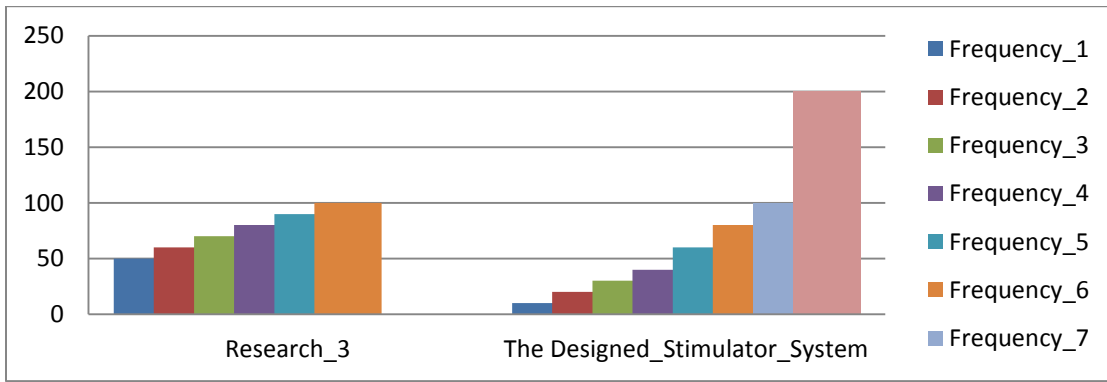
**Figure 4.17:** Pulse\_Width ( $\mu$ s) Comparisons for *the Designed\_Stimulator\_System* in Opposition to *Research\_2[5]* for *Acupuncture TENS*



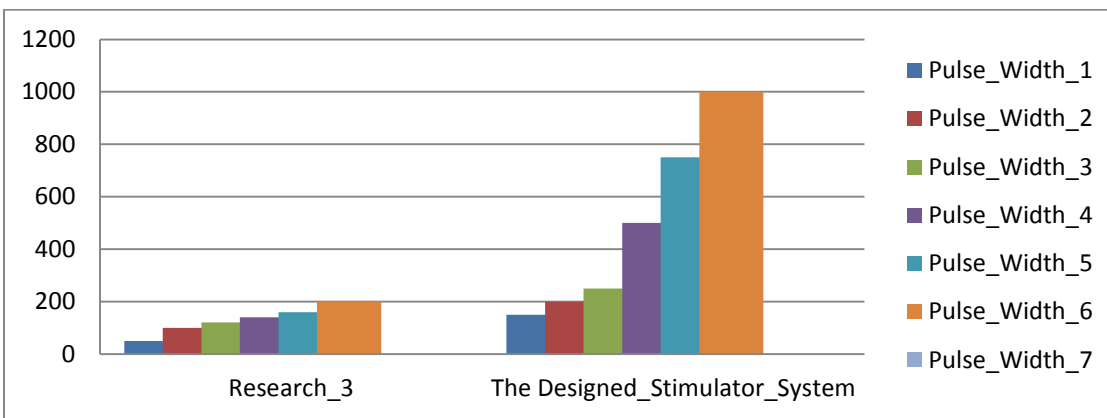
**Figure 4.18:** Frequency (Hz) Comparisons for *the Designed\_Stimulator\_System* in Opposition to *Research\_2[5]* for *Intense TENS*



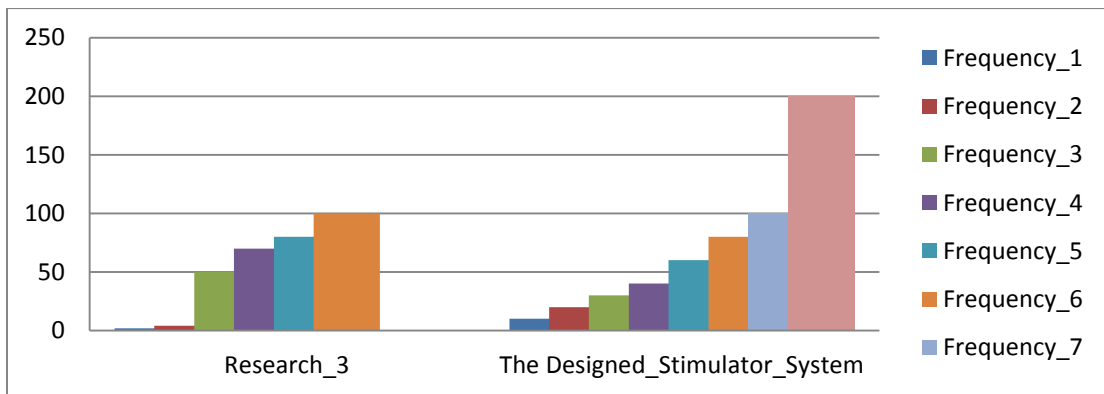
**Figure 4.19:** Pulse\_Width ( $\mu$ s) Comparisons for *the Designed\_Stimulator\_System* in Opposition to *Research\_2[5]* for *Intense TENS*



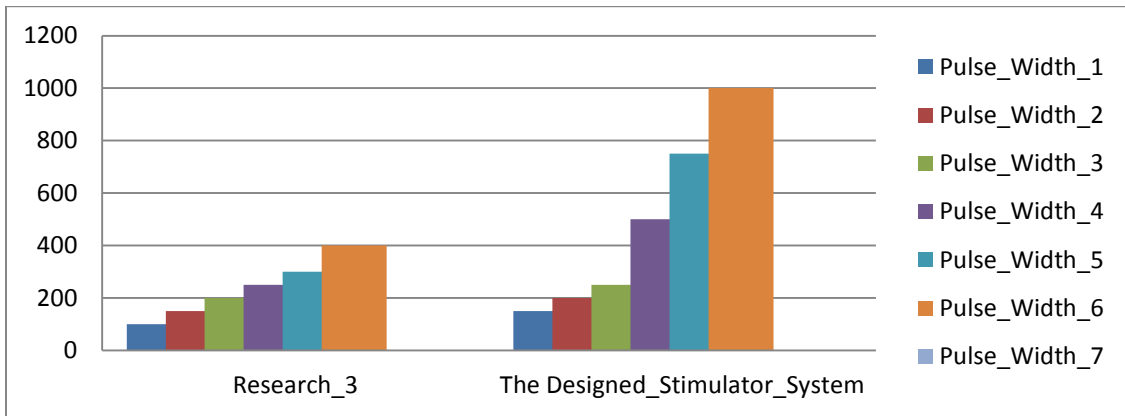
**Figure 4.20:** Frequency (Hz) Comparisons for *the Designed\_Stimulator\_System* in Opposition to *Research\_3[6]* for *Conventional TENS*



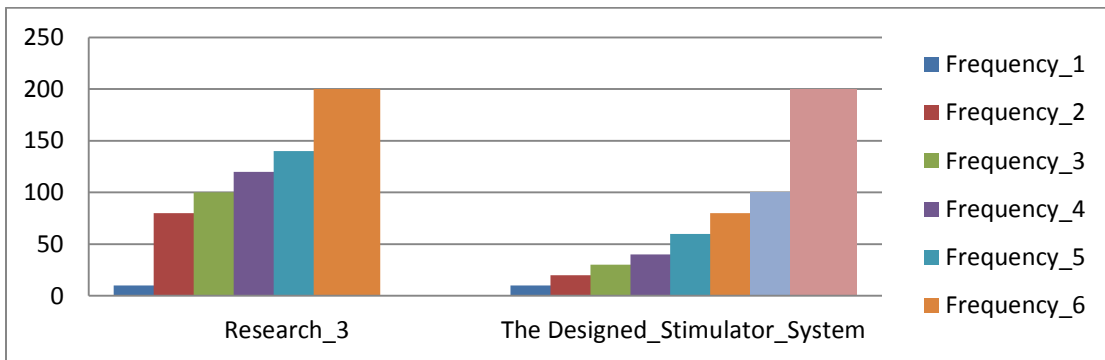
**Figure 4.21:** Pulse\_Width (µs) Comparisons for *the Designed\_Stimulator\_System* in Opposition to *Research\_3[6]* for *Conventional TENS*



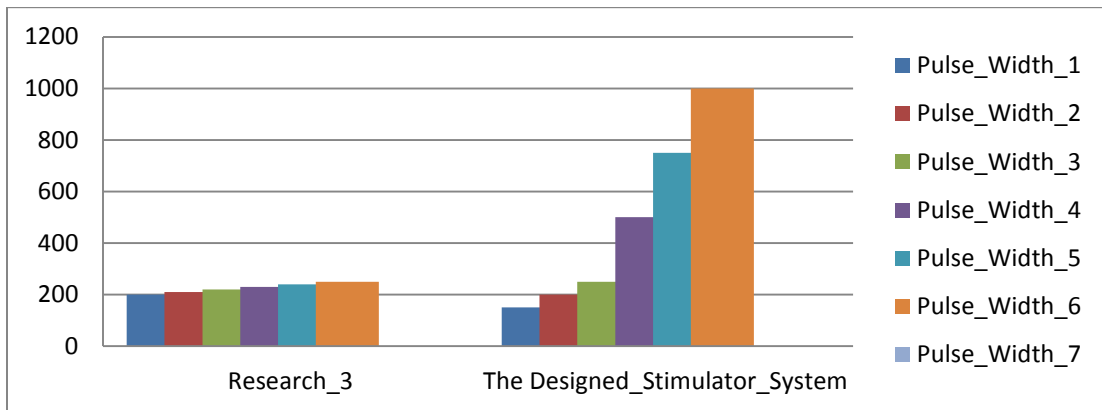
**Figure 4.22:** Frequency (Hz) Comparisons for *the Designed\_Stimulator\_System* in Opposition to *Research\_3[6]* for *Acupuncture TENS*



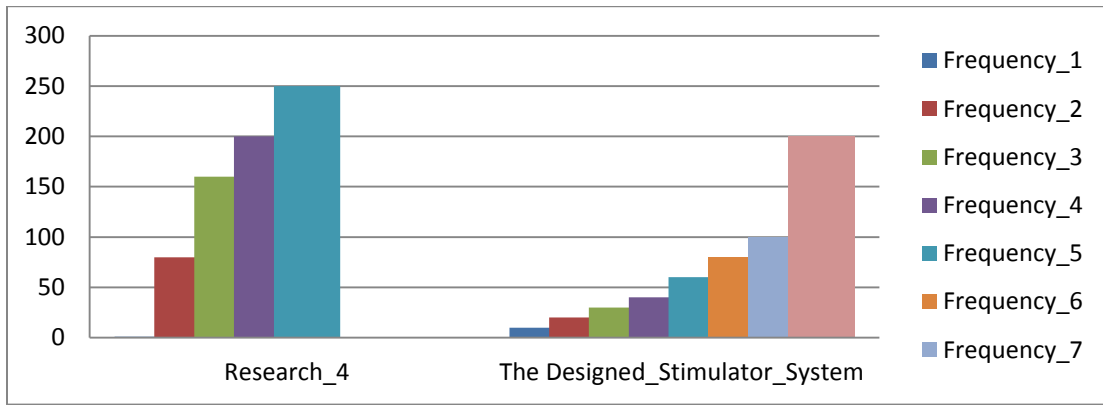
**Figure 4.23:** Pulse\_Width ( $\mu\text{s}$ ) Comparisons for *the Designed\_Stimulator\_System* in Opposition to *Research\_3[6]* for *Acupuncture TENS*



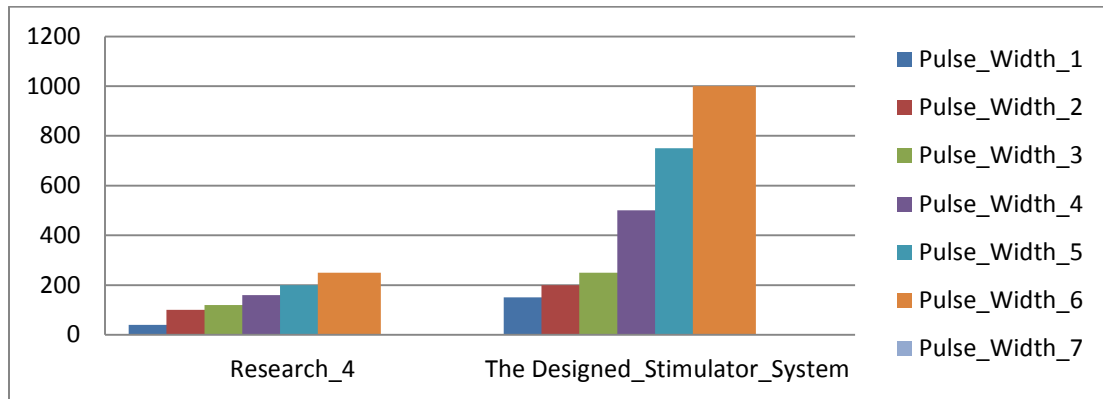
**Figure 4.24:** Frequency (Hz) Comparisons for *the Designed\_Stimulator\_System* in Opposition to *Research\_3[6]* for *Intense TENS*



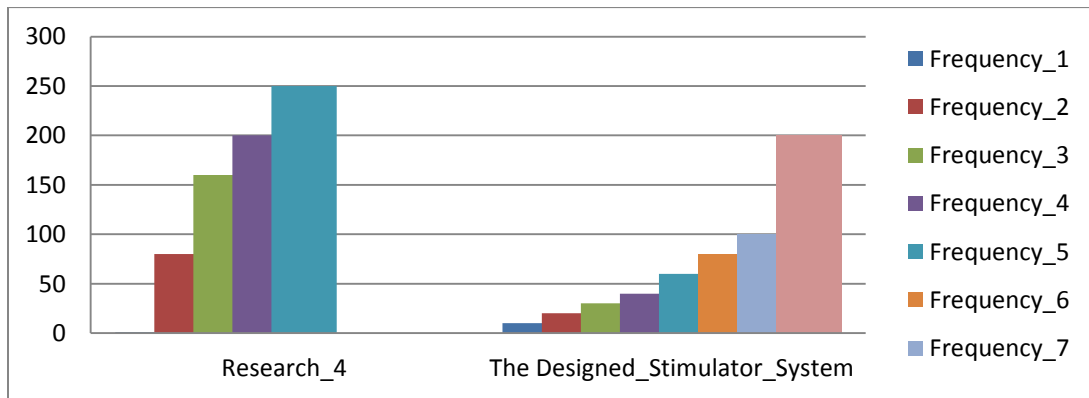
**Figure 4.25:** Pulse\_Width ( $\mu\text{s}$ ) Comparisons for *the Designed\_Stimulator\_System* in Opposition to *Research\_3[6]* for *Intense TENS*



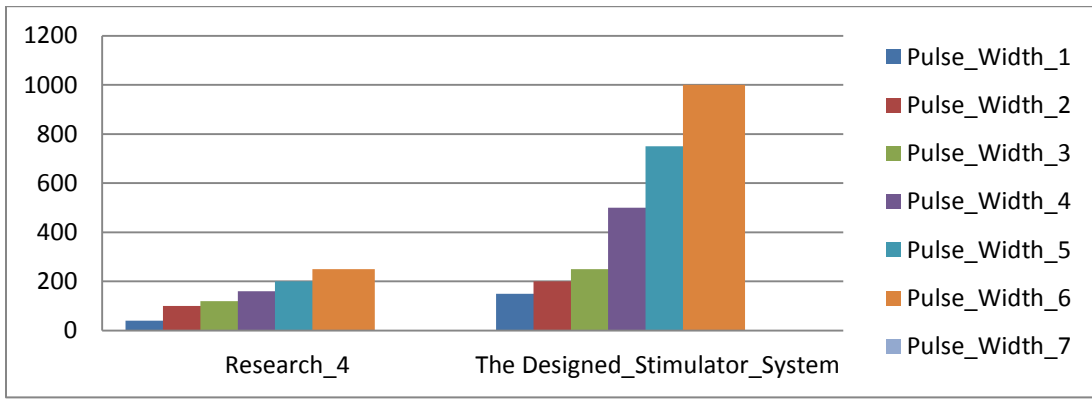
**Figure 4.26:** Frequency (Hz) Comparisons for *the Designed\_Stimulator\_System* in Opposition to *Research\_4[7]* for Conventional TENS



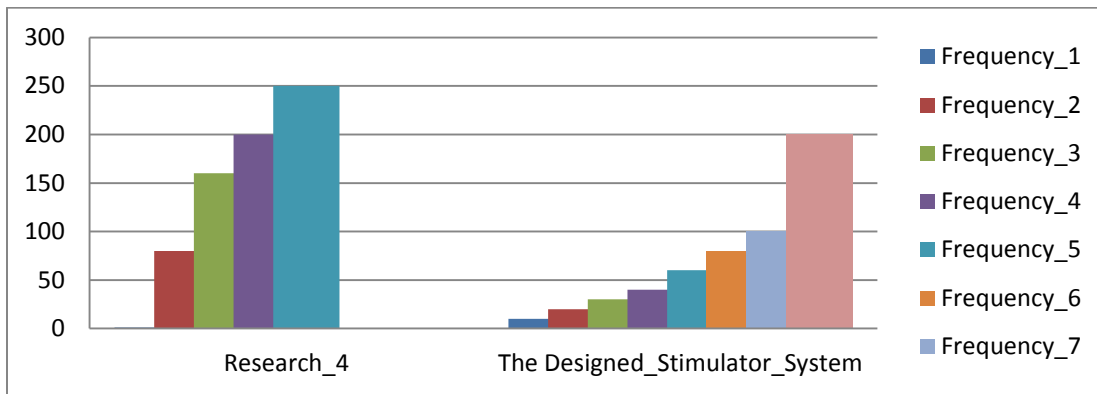
**Figure 4.27:** Pulse\_Width (µs) Comparisons for *the Designed\_Stimulator\_System* in Opposition to *Research\_4[7]* for Conventional TENS



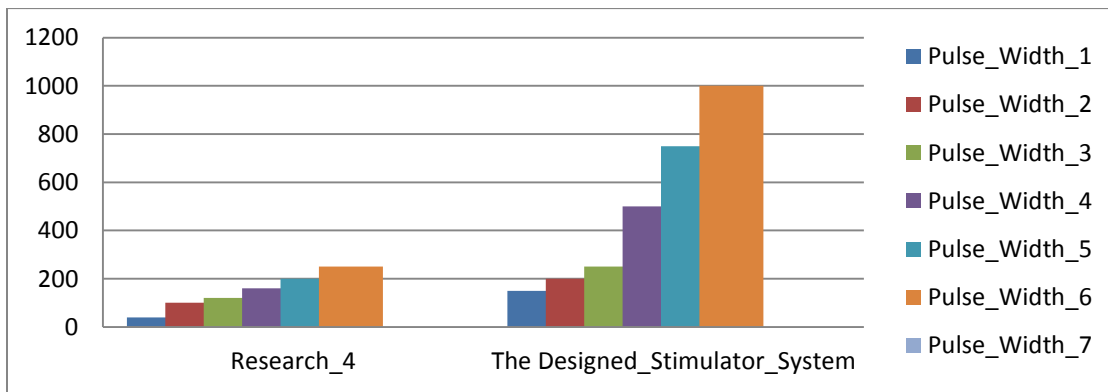
**Figure 4.28:** Frequency (Hz) Comparisons for *the Designed\_Stimulator\_System* in Opposition to *Research\_4[7]* for Acupuncture TENS



**Figure 4.29:** Pulse\_Width ( $\mu\text{s}$ ) Comparisons for *the Designed\_Stimulator\_System* in Opposition to *Research\_4[7]* for *Acupuncture TENS*



**Figure 4.30:** Frequency (Hz) Comparisons for *the Designed\_Stimulator\_System* in Opposition to *Research\_4[7]* for *Acupuncture TENS*



**Figure 4.31:** Pulse\_Width ( $\mu\text{s}$ ) Comparisons for *the Designed\_Stimulator\_System* in Opposition to *Research\_4[7]* for *Intense TENS*

Hence, the discussion for the validation of the simulation results, the thesis only consider graphs of the first baselined research from Figure 4.8 up to Figure 4.13 from the above graphs because of the mentioned reason above, so as it may be seen from Figure 4.8, frequency (Hz) comparisons of the designed\_stimulator\_system in opposition to research\_1[4] for conventional TENS technique has represented, and it shows that frequency\_6 of reseach\_1[4] and frequency\_8 of the designed\_stimulator\_system has the same frequency parameter value. Thus, it implies that the designed\_stimulator\_system has favored of one frequency parameter from research\_1[4]. And also Figure 4.9 shows, pulse\_width ( $\mu\text{s}$ ) comparisons of the designed\_stimulator\_system in opposition to research\_1[4] for conventional TENS technique has been taken, and shows that pulse\_width\_6 of research\_1[4] and pulse\_width\_2 of the designed\_stimulator\_system has the same pulse\_width parameter value which implies that the designed\_stimulator\_system has favored of one pulse\_width parameter from research\_1[4]. In this way, to arrive at from evidences above the comparison according to Figure 4.8 and 4.9, both parameters (frequency (measured in Hz or pulses per second) and pulse width (measured in  $\mu\text{s}$ )) used as a design specification for this study were not out of favor compared to research\_1[4] of the conventional TENS technique.

In a way according to Figure 4.10, frequency (Hz) comparisons of the designed\_stimulator\_system in opposition to research\_1[4] for acupuncture TENS technique, and it shows that frequency\_8 of reseach\_1[4] and frequency\_7 of the designed\_stimulator\_system has the same frequency parameter value. Hence, it implies that the designed\_stimulator\_system has favored of one frequency parameter from research\_1[4]. And as revealed in Figure 4.11, pulse\_width ( $\mu\text{s}$ ) comparisons of the designed\_stimulator\_system in opposition to research\_1[4]for acupuncture TENS technique has been taken, and here is also it shows that pulse\_width\_6 and pulse\_width\_2 of research\_1[4] and the designed\_stimulator\_system respectively has the same pulse\_width parameter value that implies the designed\_stimulator\_system has favored of one pulse\_width parameter from research\_1[4]. Thus, to arrive at from evidences above the comparison according to Figure 4.10 and 4.11, both parameters (frequency (measured in Hz or pulses per second) and pulse width (measured in  $\mu\text{s}$ )) used as a design specification for this study were not out of favor compared to research\_1[4] of the acupuncture TENS technique.

And also as reveals on Figure 4.12, frequency (Hz) comparisons of the designed\_stimulator\_system in opposition to research\_1[4] for intense TENS technique has represented, and it shows that frequency\_1 of reseach\_1[4] and frequency\_8 of the designed\_stimulator\_system has the same frequency parameter value. Hence, it implies that the designed\_stimulator\_system has favored of one frequency parameter from research\_1[4]. Likely, Figure 4.13 reveals that pulse\_width ( $\mu\text{s}$ ) comparisons of the designed\_stimulator\_system in opposition to research\_1[4] for intense TENS technique has been taken, and shows that pulse\_width\_1 of research\_1[4] and pulse\_width\_8 of the designed\_stimulator\_system has the same pulse\_width parameter value which implies that the designed\_stimulator\_system has favored of one pulse\_width parameter from research\_1[4]. To sum up and to arrive at from evidences above the comparison according to Figure 4.12 and 4.13, both parameters (frequency (measured in Hz or pulses per second) and pulse width (measured in  $\mu\text{s}$ )) used as a design specification for this study were not out of favor compared to research\_1[4] of the intense TENS mechanism of actions.

Similarly, all the rest graphs from Figure 4.14 up to Figure 4.31 which reveals the recently conducted three researches, has also validated the final results of the proposed system workability, and thesis results are at the accepted and possible level of effectiveness and inclusiveness and also favored all mechanisms of action of TENS characteristics in similar manner with the discussion that has made before for the baselined research one.

Generally, all the graphs discussed up to now presents comparison results which show parameters like pulse width and frequency of the thesis were inclusive of recently conducted researcher results, and also taken into account mechanisms of action of TENS characteristics that are conducted by the researchers. For this reason, it is concluded that the proposed system has validated and provides a new prospect and potentially enables tools of controlling different kind of pains of humans. Furthermore, the designed system gives a chance to the user to choose from the different types of stimulation parameters like amplitude, frequency, and time how long the stimulation should stay maintained.

## **4.2 Discussions**

The present thesis was completed within the given time with satisfactorily results and it is believed that the objectives of the work has fulfilled well. However, there were many software

errors as well as simulation errors experienced along with the designed system. Through the work, software errors and simulation errors were identified and finally the problems were fixed up eventually.

In regard to the software and simulation errors, there was a problem faced during software prototyping of the simulation that was caused by because of PIC16F887 microcontroller hardware call stack. On that account, PIC16F887 microcontroller have a hardware call stack, which is used to save return addresses and this hardware stack is not software-accessible. Hence, the full code of the main program for this research has had a return code inside it, when the proposed system simulate with the full programming code of the HEX file during software prototyping; stack under flow RELTW instruction problem was generated. Eventually the problem has been identified and fixed up. In addition, the work was limited to the availability of the RF 433MHz transmitter/receiver module for wireless communication.

## **5. CONCLUSION AND RECOMMENDATION**

### **5.1 Conclusion**

The goal for this thesis i.e designing and simulating TENS was achieved successfully, and tested on proteus design suit software for validating the software prototype by using PIC16F887 and arduino wireless unit based ATmega2560 and ATmega328 microcontrollers.

Based on the result obtained, it is concluded that the designed system has solved the wire/cable complexity by designing a remotely controlled stimulator system. It also provides a user friendly stimulator system, and could give a new prospect for patients who are not able to afford to the drugs because of their living standards and also potentially enables tools of controlling different kind of pains. Furthermore, the designed system gives a chance to the user to choose from the different types of stimulation parameters like amplitude, frequency, and time how long the stimulation should stay maintained.

However, the system was limited to the RF 433 MHz transmitter/receiver technologies for the wireless communication, and the designed and simulated TENS system was programmable. And also further trials will be carried out at software prototyping level for alternative pain control for patients before the system is designed and accepted for patient use.

During the research, many new experiences and knowledge were gained. Those few positive experiences gained from doing this thesis are the ability to work with people, improved writing ability, time management, testing and running of designed schematics, high description language programing skills, working and familiar with different types of microcontrollers, experience at different simulation software's. Generally, it was a wonderful experience and I truly lucky for being through and undergoes with a certain processes that contribute to my knowledge and skills.

### **5.2 Recommendation**

The designed and simulated stimulator system working satisfactorily on a software prototyping, it can be extended further by developing the hardware prototyping or by developing the PCB design of the schematics. Hence, PIC16F887 (40-pin) have a hardware call stack, which is used to save return addresses, and because the hardware stack is not software-accessible, the stack under flow problem is faced during simulating the overall system with the full programming

HEX code. So, the system could be overcome this problem by further implementing the hardware prototyping.

Similarly, this thesis work is limited to the availability of the RF 433MHz transmitter/receiver module for wireless communication. The proposed system could be designed further using different wireless technologies such as the Bluetooth technology, infrared technology or the ZigBee RF technology to communicate between the arduino microcontroller units, during the future developments simulator will provide more effective results. Hence, the designed system was programmable it could be further improved by modifying the program functions.

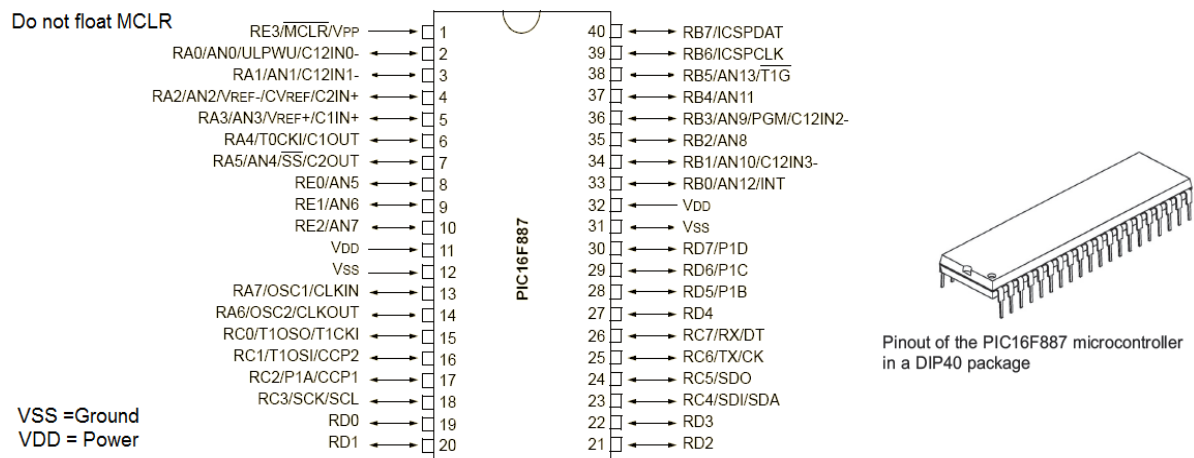


## APPENDIX 2: Main and Sub Microcontroller, and Communication Modules Details Used by the Thesis

### Main Microcontroller

#### The PIC16F887 MCU [40]

The PIC16F887 type controller is a production of Microchip which is built on Ready for PIC board. It is a feature that almost all the modern microcontrollers' modules should be, and practical modality in such application as the control of different processes in industry, measurement of different values etc. because of high quality, wide range of application, low power consumption, low price and easy availability are important factor in preference of the controller. PIC16F887 microcontrollers are pre-programmed by an UART bootloader firmware and thus eliminate the requirement of the external programmers. The on-board USB-UART modules allow the serial data transfer between the PIC and a PC using an USB cable. It has also got a reasonable size prototyping area to add more functionality to the board as required [40].



**Figure 3** PIC16F887 Pin Configurations [40]

#### The Basic Features of PIC16F887

- RISC architecture (Reduced Instruction Set Computer)
  - Only 35 instructions
  - All single-cycle instructions except branches
- Operating frequency 0-20 MHz
- Precision internal oscillator
  - Factory calibrated

- Software selectable frequency range of 8MHz to 31KHz
- Power supply voltage 2.0-5.5V
  - Consumption: 220uA (2.0V, 4MHz), 11uA (2.0 V, 32 KHz) 50nA (stand-by mode)
- Power-Saving Sleep Mode
- Brown-out Reset (BOR) with software control option
- 35 input/output pins
  - High current source/sink for direct LED drive
  - Software and individually programmable pull-up resistor
  - Interrupt-on-Change pin
- 8K ROM memory in FLASH technology
  - Chip can be reprogrammed up to 100.000 times
- In-Circuit Serial Programming Option
  - Chip can be programmed even embedded in the target device
- 256 bytes EEPROM memory
  - Data can be written more than 1.000.000 times
- 368 bytes RAM memory
- Analog to digital converter:
  - 14-channels
  - 10-bit resolution
- Three (3) independent timers/counters
- Watch-dog timer
- Analogue comparator module with
  - Two analogue comparators
  - Fixed voltage reference (0.6V)
  - Programmable on-chip voltage reference
- PWM output steering control
- Enhanced USART module
  - Supports RS-485, RS-232 and LIN2.0
  - Auto-Baud Detect
- Master Synchronous Serial Port (MSSP)supports SPI and I2C mode

## Memory of PIC16F887

The PIC16F887 has three types of memory ROM, RAM and EEPROM. All of them will be separately discussed since each has specific functions, features and organization.

### ROM Memory

ROM memory is used to permanently save the program being executed. This is why it is often called 'program memory'. The PIC16F887 has 8Kb of ROM (in total of 8192 locations). Since the ROM memory is made with FLASH technology, its contents can be changed by providing a special programming voltage (13V).

### EEPROM Memory

Similar to program memory, the contents of EEPROM is permanently saved, even when the power goes off. However, unlike ROM, the contents of EEPROM can be changed during the operation of the microcontroller. This is why this memory (256 locations) is perfect for permanently saving some of the results created and used during the operation.

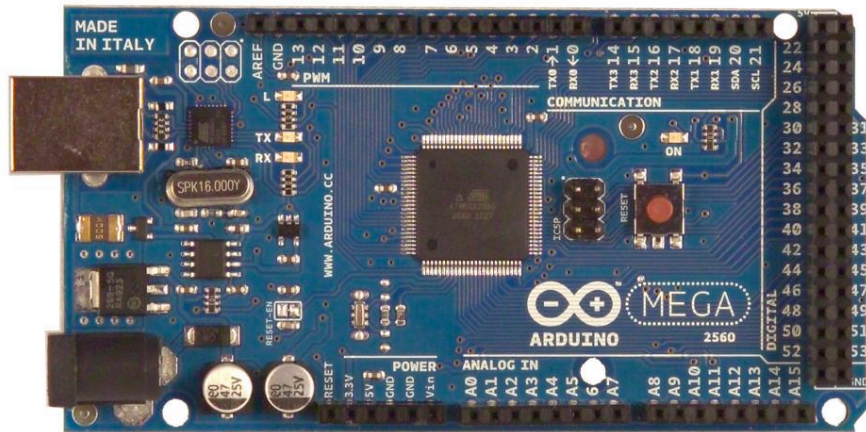
### RAM Memory

This is the third and the most complex part of microcontroller memory. In this case, it consists of two parts: general-purpose registers and special-function registers (SFR). All these registers are divided in four memory banks. Even though both groups of registers are cleared when power go off and even though they are manufactured in the same manner and act in a similar way, their functions do not have many things in common [41].

## Sub-Microcontrollers

The Arduino board is a single-board microcontroller employing an Atmel AVR 8-bit or 32-bit microcontroller. In the proposed system, Arduino Mega 2560 and Arduino Uno 328 with RF 433MHz transmitter/receiver module were used for wireless communication unit.

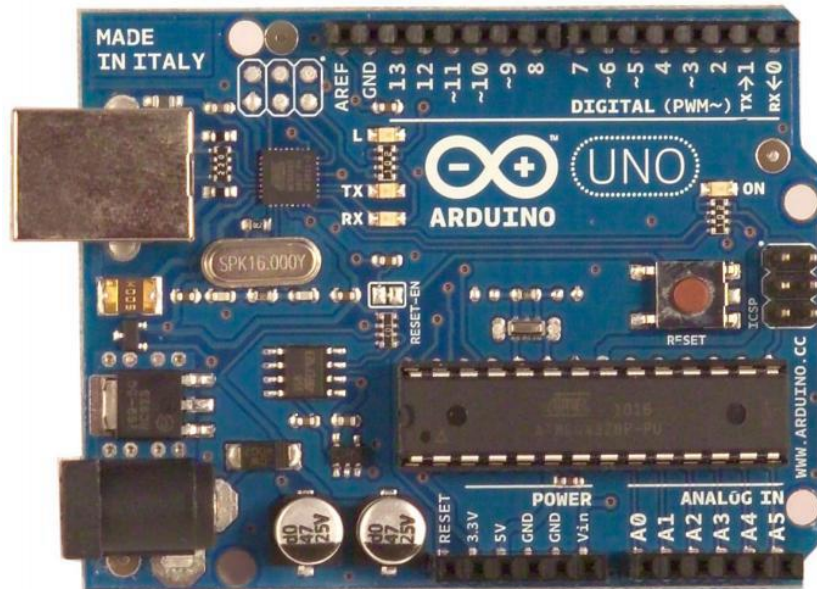
AT-mega 2560



**Figure 4** Arduino Mega 2560 [42]

The Arduino Mega 2560 is a microcontroller board based on the ATmega 2560. It has 54 digital input/output pins (of which 14 can be used as PWM outputs), 16 analog inputs, 4 UARTs (hardware serial ports), a 16 MHz crystal oscillator, a USB connection, a power jack, an ICSP header, and a reset button. It contains everything needed to support the microcontroller; simply connect it to a computer with a USB cable or power it with AC-to-DC adapter or battery to get started [42].

AT-mega 328



**Figure 5** ATmega 328 [43]

Arduino UNO is a microcontroller board based on the ATmega 328. This board receives the digital signal from the RF receiver and forwards it to the microcontroller ATmega328. But microcontroller cannot directly receive the signal, so for this purpose Arduino UNO board is used. Arduino has 14 pins which all can work as input/output pins. In these pins 6 pins can be used as Pulse Width Modulation (PWM) outputs, 16MHz crystal oscillator, analog output, connection for USB, reset button, power jack and ICSP header. Even it has all those things which need to support our microcontroller; it can be connecting to computer simply via USB cable. Arduino UNO board can be powered by AC to DC adapter. Arduino UNO board does not use FTDI USB to serial driver chip, that's why it is different from all other boards [43].

### Arduino Board Communication

The thesis has used Arduino microcontroller because it has so many facilities to communicate with the computer and the microcontroller. Arduino can communicate with other Arduino boards. ATmega 2560 provides 4 hardware UART TTL (5V) serial communications. Microcontroller ATmega328 gives UART TTL serial communication with the help of digital pin 0 (Transmitter) and digital pin 0 (Receiver). On the board for serial communication through USB we have ATmega8U2 which appears as virtual com port to software on the computer. There is no need to any external driver if 8U2 firmware uses the standard USB com driver.

The receiver and transmitter LEDs on the board flashes when the data is send through the USB serial chip and through USB communication port of the computer. This is the Arduino serial monitor, which allows data to transmit and receive from the Arduino board. One can use any digital pin for serial communication by using software serial library.

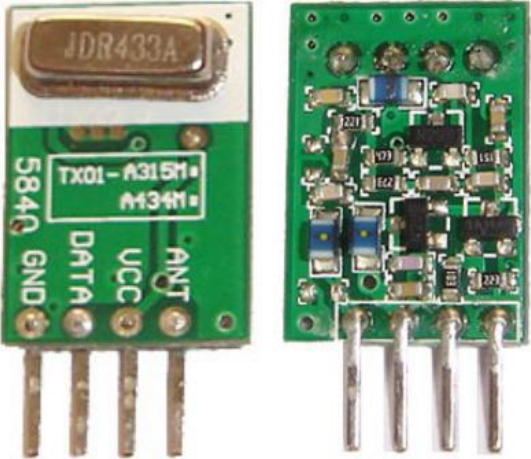
### Transmitter and Receiver

Looking on a wireless communication between two Arduino boards, options like Xbee or Bluetooth were going to cost too much compare to RF transmitter and receiver. So, RF transmitter and receiver are cheap and pretty easy to use. Taking into consideration the above points, the proposed system is working with RF 433MHz transmitter and receiver, and used for ideal application of a system with remote control and low power consumption [44].

### RF 433MHz Transmitter

A perfect RF transmitter for low cost and long range is required for such experiment. Thus RF 433MHz transmitter is placed for transmitting the signal. It operates from a supply of 1.5 to 12

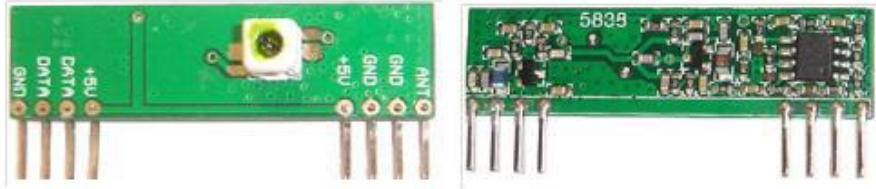
volts. It employs a SAW-stabilized oscillator, ensuring accurate frequency control for best range performance.



**Figure 6** RF 433 MHz Transmitters [Adopted from: [44]]

RF 433MHz Receiver

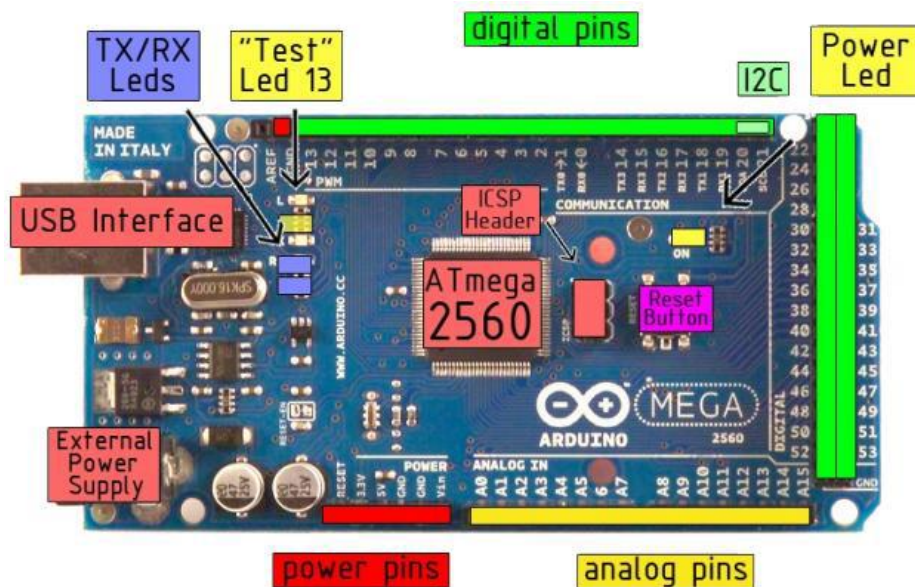
RF 433MHz Receiver with the same frequency is going to use like RF 433MHz Transmitter used in the transmitter part. RF 433MHz Receiver is very ideal for the short range remote control application. It is low cost and does not need any external RF components except antenna.



**Figure7** RF 433MHz Receiver [Adopted from: [44]]

## AT-mega 2560

The different component in the microcontroller has been defined in the figure below.



**Figure 8** ATmega 2560 with defined components [42]

### Power pin description

Power pins descriptions of ATmega 2560:

- Vin: this pin is used to power jack while using AC to DC external voltage.
- 5V: this 5V is, the power supply used to give to the microcontroller and other components, given by a USB or Vin
- 3.3V: this amount of voltage is supplied from on board regulator. Maximum current draw is 50mA.
- GND: simply ground pins.

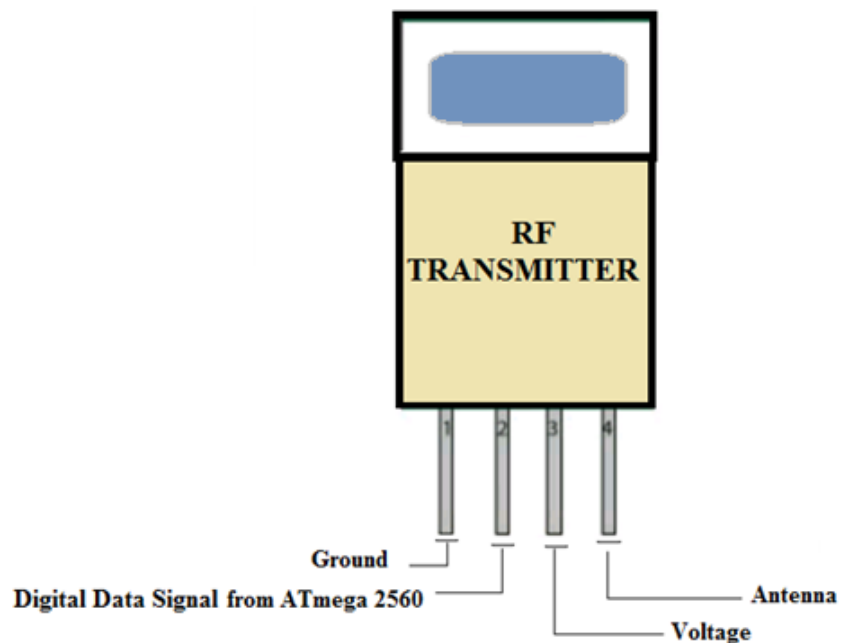
### Input and output

ATmega 2560 microcontroller has 54 input and output pins. All the pins can be used as input or output on an operating voltage at 5V. They can provide and receive a maximum of 40mA. They have an internal resistance of 20-50kOhms. Some of the pins have specialized functions as follow:

- Serial: 0 (RX) and 1 (TX); Serial 1: 19 (RX) and 18 (TX); Serial 2: 17 (RX) and 16 (TX); Serial 3: 15 (RX) and 14 (TX). RX is used to receive and TX is used to transmit TTL data.

- External Interrupts: 2 (interrupt 0), 3 (interrupt 1), 18 (interrupt 5), 19 (interrupt 4), 20 (interrupt 3), and 21 (interrupt 2). These pins can be configured to trigger an interrupt on a low value, a rising or falling edge, or a change in value.
- PWM: 0 to 13. 8-bit PWM output is provided with the “analogWrite()” function.
- SPI: 50 (MISO), 51 (MOSI), 52 (SCK), 53 (SS). They have the ability to support SPI communication.
- LED: 13. As the name concludes itself that a built-in LED is connected to this pin 13.
- I<sup>2</sup>C: 20 (SDA) and 21 (SCL). Pins 20 and 21 are used for TWI communication.

### RF 433 MHz Transmitter



**Figure 9** Mechanical Diagram of transmitter [Adopted from: [44]]

**Table 1** RF Transmitter [Adopted from: [44]]

Pin No.	Name	Function
1	GND	Ground (0V)
2	DATA	Serial Data Input
3	VCC	Supply Voltage (5V)
4	ANT	Antenna Output

## Pin Description

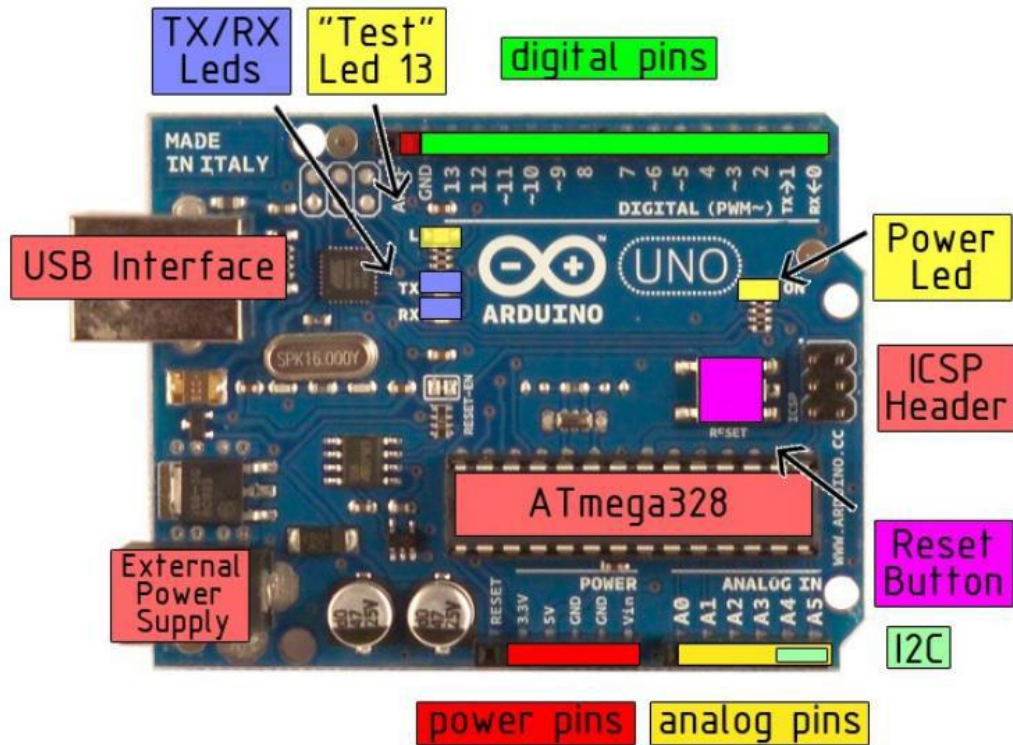
- ANT (Antenna): The resistance of the antenna is 50 ohm. And the impedance affects the harmonic emissions and the output power. So for this purpose an LC low-pass filter is used to filter the harmonic emissions.
- VCC (Voltage): VCC is the required voltage for the operating of the transmitter. Two capacitors should be used for degradation of the noise otherwise it will affect the transmitter performance.
- DATA: The data pin get digital signal from ATmega 2560 and transmitted it.
- GND (Ground): This is the transmitter ground connect to ground plane.

## Operation:

On Off Keying (OOK) is a binary form of amplitude modulation. When logical '0' is being sent, the transmitter is off, fully suppressing the carrier, and the transmitter current is very low less than 1mA. When logical '1' is being sent the transmitter carrier is fully on and the module current at its highest it's about 11mA with 3V power supply.

On Off Keying is a method for modulation which is best choice for the remote control application where power consumption and cost matters. When transmitter does not transmit data at that time no power consume.

## AT-mega 328



**Figure 10** ATmega 328 with defined components [43]

### Power Pins Description

Power pins descriptions of ATmega328:

- $V_{in}$ : When applying external voltage AC to DC we use pin  $V_{in}$  to power jack.
- 5V: Arduino UNO board give 5V regulated power supply to microcontroller and to other components. The voltage can be provided from either USB or from  $V_{in}$ .
- 3V3: The Arduino board can generate 3.3V supply from on board regulator and in this case 50mA maximum current draw.
- GND: Ground pin.

### Input and Output

There are 14 digital input output pins on Arduino UNO board in which any one can be used as input or output pin and the operating voltage will be 5V. Every pin has internal pull up resistors of 20-50k $\Omega$  and these resistors are disconnected by default. Each pin can provide or receives maximum of 40mA.

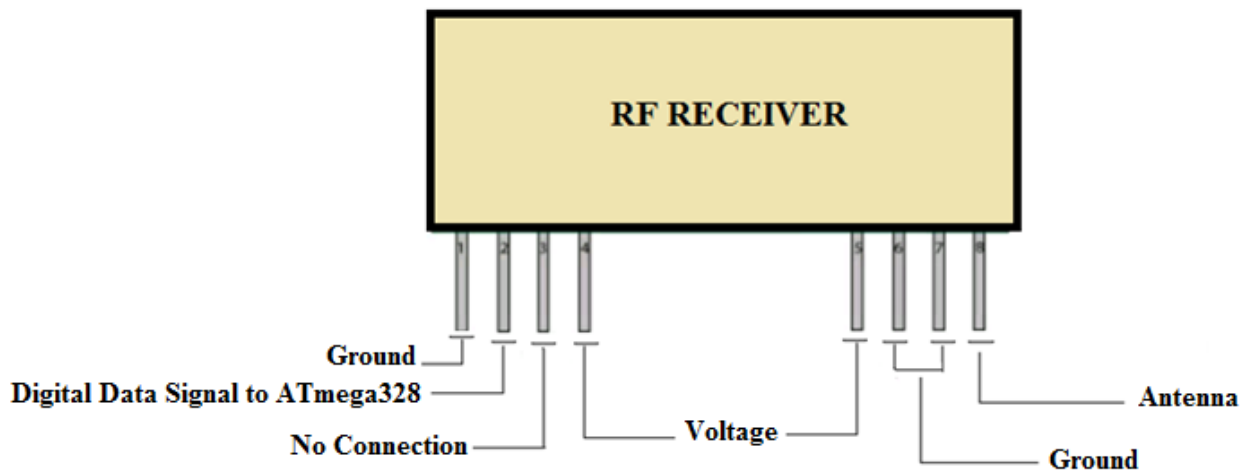
- Serial: 0(Rx) and Serial 1(Tx) This pin is use to receive and transmit TTL serial data and connect to ATmega8U2 USB to TTL serial chip.
- External Interrupts 2 and 3: These pins are triggering pins and configured to use for trigger an interrupt on a low value, change in value a rising or falling edge.
- Pulse Width Modulation: Pin 3, 5, 6, 9, 10 and 11 provide 8 bit PWM output.
- SPI: Pin 10(SS), 11(MOSI),12(MISO), 13(SCK) support SPI communication. It is not included in the Arduino programming language because it is provide by the underlying hardware.
- LED: Pin 13 is connect to build in LED, it depends on the pin value if its value is low the LED is off and when the value is high LED is on.

The Arduino board has 6 analog pins as input, by default the can measure from ground to 5V, every analog pin provides 10 bits of resolution. If one want to change the upper range of the voltage he can change it by using the AREF pin and the “analogReference()” function.

In Arduino UNO we have some specialized functional pins also.

- I<sup>2</sup>C: 4(SDA) and 6(SCL). By using the wire library I<sup>2</sup>C (TWI) can communicate.
- AREF and Reset are also special pins on the Arduino board.

### RF 433 Receiver



**Figure 11** Pin configuration of receiver [Adopted from: [44]]

**Table 2** RF Receiver [Adopted from: [44]]

Pin No.	Name	Function
1	GND	Ground (0V)

2	DATA	Serial Data Output
3	NC	No Connection
4	VCC	Supply Voltage (5V)
5	VCC	Supply Voltage (5V)
6	GND	Ground (0V)
7	GND	Ground (0V)
8	ANT	Antenna Input

### Pin Description

- ANT (Antenna): Receiver receives its input through the antenna.
- GND (Ground): Receiver ground.
- VCC: Pin VCC provides the operating voltage which is connect electrically. Here in this circuit one can see that we have two VCC pins we can provide VCC to one pin or both pins. VCC should be bypassed with .1 $\mu$ F ceramic capacitor.
- DATA: This pin gives digital data which has received from the antenna and forwarded to decoder. This is also CMOS compatible output.

### How it Operate?

#### Super Regenerative AM Detection

Receiver RF-433MHz using super regenerative AM detector to demodulate the incoming AM carrier. This detector has a positive feedback gain stage which is greater than “1” or unity so that it oscillates. When the gain stage oscillates an RC time constant include gaining stage. And this gain is lower over time proportional to the RC time constant until the oscillation dies, after the oscillation stop or dies gaining stage decrease, and start charging the RC circuit which increases the gain and oscillation begins again. So like this every time the oscillation of the gain stage turn off and turned on and for this RC time constant sets the rate. This rate should super audible and it should be lower than the original rate of oscillation. At the frequency of the main oscillation every input RF signal will be add in restarting. Amplitude of the RF input is directly proportional to the staying of the main oscillation period of time. This means that if amplitude of the input RF is increases the main oscillation will stay for longer period of time with the higher emitter current. That’s why it is easy to detect the real base-band signal by using ordinary low pass filtering emitter current.

### Data Slicer

The base band analogue signal from the super regenerative detector converts by data slicer to TTL or CMOS compatible output. Data slice is AC coupled with the audio output, because the data rate is very less here. Maximum and minimum pulse width is always limited by the AC coupling. We usually use non return to zero (NRZ) or pulse width modulation (PWM) to encode the data on the transmitting side.

Those applications which uses the NRZ data encoding use microcontrollers, the common source of NRZ data is UART which is built in microcontroller. In case of PWM the common source is a remote control IC like HC-12E or ST14 CODEC. PWM encoded data is used in this receiver with data slicer but it functions with NRZ if the specific rule follows.

### Power Supply

The power consumption in this thesis is a primary concern so for this work the receiver RF-433MHz is a best choice because it is specially designed for the low power consumption with 5V power supply. Power supply is by passed by two capacitors .1 $\mu$ F and .47 $\mu$ F ceramic and tantalum respectively. It takes 750mSec to output valid data after powered.

### Antenna Input

Different type of antennas can be used with the RF 433 MHz Receivers and sometimes integrated printed antennas and single core wire. Performance of the antenna is depending upon the type of the antenna.

### **APPENDIX 3: The Designed and Simulated Wireless Based TENS Device for Pain Control Program Codes for PIC16F887 Controller**

The stimulator includes an electrical stimulation generator which consists of main PIC microcontroller. The microcontroller is a programming unit for controlling the electrical stimulation which helps to regulate the operation through a plurality of different modes. Each mode is intended to administer treatment via a specific waveform. In addition to the microcontroller there is also a remote control unit which is basically important to make the electrical stimulation generator unit ON and OFF, both sections are connected through a wireless communication unit. The electrical stimulation generator unit includes output terminals for delivery of electrical stimulator to electrodes, main program for use in determining its mode of operation, a power source for the circuitry, and two push button switches named SET and MODE, which are used to configure the operational parameters, such as the pulse-width, operation profile, and the frequency. In this proposed system, eight levels of frequency, six levels of pulse-width, and four selectable stages are available.

One part of the design in the research comprises the remote controlling unit which includes a plurality of a keypad analog controls and indicator lights to provide control over electrical stimulation generator unit. The other design part of the research, the electrical stimulation generator includes liquid crystal display, which allows the operator to verify the modes and parameters. Further, the designed system is capable of delivering a variety of Waveforms to patient tissue, with varying amplitude according to the patient's comfort level, so as to be capable of treating a variety of physical conditions both acute and chronic.

In short, the designed and simulated system enters the configuration stage if the MODE key is pressed while the power is applied or system is Reset.

During the configuration mode the FREQUENCY and the PULSE WIDTH can be set as desired by pressing the SET key.

During the configuration phase the following frequency, pulse-width, and stages can be selected by the user.

Pressing the SET key goes through the options.

Pressing the MODE key moves from the Frequency selection menu to the PULSE-WIDTH selection menu and then to the STAGE selection menu.

Frequencies that can be selected:

10Hz, 20Hz, 30Hz, 40Hz, 60Hz, 80Hz, 100Hz, 200Hz

Pulse-width that can be selected:

150µs, 200 µs, 250 µs, 500 µs, 750 µs, 1000 µs

Stages that can be selected:

Stage 1, 2, 3, 4

The designed and simulated wireless TENS stimulator device in this thesis, four (4) selectable and configurable stages have been described with different timing requirements that may be suitable for different users. These stages timing selections are shown below in the table. Upon activation, preferred treatment program will automatically proceed through four stages, over a total period of forty minutes, forty seconds, as summarized in the following table:

	Ramp Down	Ramp Up	Fixed-Time
Stage-1	12 seconds	12 seconds	5 minutes (300sec)
Stage-2	4 seconds	4 seconds	15 minutes(900sec)
Stage-3	12 seconds	12 seconds	5 minutes(300sec)
Stage-4	4 seconds	4 seconds	10 minutes(600sec)

This particular form of the program is based on using a PIC16F887 microcontroller which is supported by the RF 433MHz transmitter and receiver and keypad push switch, with 2 electrodes, placed on the surface of skin of the patient.

// Declare the variables used in the program

```
unsigned char TMR0Value;

unsigned char Ramp_Up;

unsigned char Ramp_Down;

unsigned char Fixed_Time;

unsigned char TMR1HValue;

unsigned char TMR1LValue;

unsigned char frequency;

unsigned char pw_high;

unsigned char pw_low;

unsigned int pulse_width;

unsigned int temp_pulse_width;

unsigned int TMR1Value;

unsigned long Period;

float TimerValue;

// Define the various symbols used in the program

#define MODE PORTB.RB0

#define SET PORTB.RB1

#define MOSFET PORTC.RC0

#define Keypad_Switch_Button PORTC.RC1

#define Keypad_Switch_Button_Enable 1

#define Keypad_Switch_Button_Disable 0
```

```

#define Enable_Stimulation INTCON.GIE = 1

#define Disable_Stimulation INTCON.GIE = 0

// LCD module connections

sbit LCD_RS at RD2_bit;

sbit LCD_EN at RD3_bit;

sbit LCD_D4 at RD4_bit;

sbit LCD_D5 at RD5_bit;

sbit LCD_D6 at RD6_bit;

sbit LCD_D7 at RD7_bit;

// LCD pin directions

sbitLCD_RS_Direction at TRISD2_bit;

sbitLCD_EN_Direction at TRISD3_bit;

sbit LCD_D4_Direction at TRISD4_bit;

sbit LCD_D5_Direction at TRISD5_bit;

sbit LCD_D6_Direction at TRISD6_bit;

sbit LCD_D7_Direction at TRISD7_bit;

// End LCD module connections

```

TIMER INTERRUPTS service routine (ISR)

Both TMR0 and TMR1 timer interrupts are serviced here TMR0 is used to generate the PULSE WIDTH, and TMR1 is used to generate the required FREQUENCY of the waveform. The following Program Description Language (PDL) describes how the waveforms are generated by the two timers (Here, PIN is the output of the PIC16F887 microcontroller that drives the MOSFET):

Set PIN ON

Load TMR0 with Pulse-width

Load TMR1 with frequency

Start TMR0

Start TMR1

Enable TMR0, TMR1 interrupts

Wait for interrupts

TMR0 ISR:

Toggle PIN

Return from interrupt

TMR1 ISR:

Toggle PIN

Reload TMR0

Reload TMR1

Enable TMR0 interrupts

Note That: Some programing Codes Were Missed Intentionally.

## **APPENDIX 4: Wireless Communication Unit Program Codes for Receiver (ATmega2560) and Transmitter (ATmega328) Parts**

### **Transmitter:**

```
/*  
  
ATmega2560 Transmitter  
  
*/  
  
intledPin = 13;           // integer variable led is declared (select the pin for the LED)  
  
intCMOS_outputPin = A0;   // selection of the CMOS circuit output pin as an input  
  
int voltage = 0;         // variable to store the brightness and voltage of the LED when keypad  
switch button is off to the ground  
  
intCMOSValue = 0;        // variables to store incoming value from the CMOS circuit  
  
intlastValue = 0;  
  
int volt=0;              // Variable to store the last value of the CMOS circuit voltage  
  
void setup()             // the setup() method is executed only once
```

### **Receiver:**

```
/*  
  
ATmega328 Receiver  
  
*/  
  
charinString[6];  
  
intinByte = -1;  
  
intlastValue = 0;  
  
intstringPos = 0;
```

```
int voltpin=13;
```

```
void setup()
```

Note That: Some programing Codes Were Missed Intentionally.

## REFERENCES

- [1] Dr Danielle et al., An introduction to pain pathways and mechanisms. University College London Hospital, London, 2013.
- [2] Treat the Pain: A COUNTRY SNAPSHOT [Internet]. 2014 [cited 2015 January 28]. Available from: [www.treatthepain.org](http://www.treatthepain.org)
- [3] Alebachew, Abebe, Laurel Hatt, Matt Kukla, Sharon Nakhimovsky. April 2014. Universal Health Coverage Measurement in a Low--Income Context: An Ethiopian Case Study. Bethesda, MD: Health Finance & Governance Project, Abt Associates Inc...
- [4] Johnson M. (2002) Transcutaneous electrical nerve stimulation (TENS). In Sheila Kitchen (ed) Electrotherapy: evidence based practice. (11<sup>th</sup> ed) Churchill Livingstone. Watson T [www.electrotherapy.org](http://www.electrotherapy.org)
- [5] "Using Your TENS Unit: University Hospital Of South Manchester NHS Foundation Trust" Editorial No: 0545/07. B Verrall. Reviewed April 2007. ReviewDate Due: April 09.
- [6] Banerjee G, Johnson MI, Transcutaneous electrical nerve stimulation (TENS): A potential intervention for pain management in India? *India J Pain* 2013; 27:132-42
- [7] Sukhyanti Kerai, Kirti Nath Saxena, Lalit Sehrawt, Bharti Taneja. Role of transcutaneous electrical nerve stimulation (TENS) in post-operative analgesia, *Indian Journal Anesthesia*, Vol. 58, No. 4, July-August, 2014, pp.388-393
- [8] [https://commons.wikimedia.org/wiki/File:Nervous\\_system\\_diagram.png](https://commons.wikimedia.org/wiki/File:Nervous_system_diagram.png) [Retrieved April 12, 2015]
- [9] [www.msu.edu/course/asc/333/casby/myelin.jpg](http://www.msu.edu/course/asc/333/casby/myelin.jpg) [Retrieved April 12, 2015]
- [10] Kenneth Jerome F. M. "The Design Applied to the Development of Orthopedic Transcutaneous Electrical Nerve Stimulation (TENS) Devices for the Treatment of Acute Pain" Thesis in Mechanical Engineering. Massachusetts Institute of Technology, 1999.
- [11] <http://www.blackwellpublishing.com/patestas/chapters/10.pdf> [Retrieved April 20, 2015]
- [12] Dr Danielle et al., Basics of transcutaneous electrical nerve stimulation (TENS). University College London Hospital, London, 2012.
- [13] Okafor et al., *Journal of Veterinary Medicine and Animal Health*, Volume 6, Number 5 May, 2014
- [14] <https://www.ucl.ac.uk/anaesthesia/StudentsandTrainees/PainPathwaysIntroduction> [Retrieved April 24, 2015]

- [15] Melzack, R. and P.D. Wall, Pain Mechanisms: A New Theory. *Science*, 1965, 150(3699): p.971-979.
- [16] <https://www.ucl.ac.uk/anaesthesia/StudentsandTrainees/PainPathwaysIntroduction>  
[Retrieved April 24, 2015]
- [17] <https://www.sheffieldpersistentpain.com/persistent-pain/what-is-persistent-pain/the-cycle-of-pain/> Retrieved April 29, 2015
- [18] Walsh D. TENS. Clinical applications and related theory. New York: Churchill Livingstone, 1997.
- [19] Johnson M. Transcutaneous electrical nerve stimulation (TENS). In: Kitchen S ed. *Electrotherapy: evidence-based practice*. Edinburgh: Churchill Livingstone, 2001: 259–86.
- [20] Chabal C, Fishbain DA, Weaver M, Heine LW. Long-term transcutaneous electrical nerve stimulation (TENS) use: impact on medication utilization and physical therapy costs. *Clin J Pain* 1998; 14: 66–73.
- [21] Kane, K, Taub, A (1975) A history of local electrical analgesia. *Pain* 1: 125–138.
- [22] Stillings, D (1975) A survey of the history of electrical stimulation for pain to 1900. *Medical Instrumentation* 9: 255–259.
- [23] Wall, PD, Sweet, WH (1967) Temporary abolition of pain in man. *Science* 155: 108–109.
- [24] Reynolds, DV (1969) Surgery in the rat during electrical analgesia induced by focal brain stimulation. *Science* 164: 444–445.
- [25] Shealy, CN, Mortimer, JT, Reswick, JB (1967) Electrical inhibition of pain by stimulation of the dorsal columns: preliminary clinical report. *Anesthesia and Analgesia* 46: 489–491.
- [26] Long, DM (1973) Electrical stimulation for relief of pain from chronic nerve injury. *Journal of Neurosurgery* 39: 718–722.
- [27] Long, DM (1974) External electrical stimulation as a treatment of chronic pain. *Minnesota Medicine* 57: 195–198.
- [28] Sheila Kitchen, *Electrotherapy Evidence-Based Practice*. 11 ed. 2001, Leeds Metropolitan University, UK: Churchill Livingstone.
- [29] Doc. J.N., An evaluation of transcutaneous electrical nerve stimulation TENS for the treatment of pain related to a spinal cord. Thesis in Clinical Psychology. 1996, University of California, San Diego and San Diego university: San Diego, CA. 155.

- [30] Woolf C, Thompson J Segmental afferent fibre-induced analgesia: transcutaneous electrical nerve stimulation (TENS) and vibration. In: Wall P, Melzack R eds. Textbook of pain. Edinburgh: Churchill Livingstone, 1994: 1191–208.
- [31] Walsh, D (1997d) TENS: physiological principles and stimulation parameters. In: Walsh, D (ed) TENS. Clinical Applications and Related Theory. Churchill Livingstone, New York; pp 25-40.
- [32] Eriksson MB, Sjölund BH. Acupuncture-like electro analgesia in TNS resistant chronic pain. In: Zotterman Y ed. Sensory functions of the skin. Oxford: Pergamon Press, 1976: 575–81.
- [33] Melzack R, Vetere P, Finch L. Transcutaneous electrical nerve stimulation for low back pain. A comparison of TENS and massage for pain and range of motion. *Phys Ther* 1983; 63: 489–93.
- [34] Carrol EN, Badura AS. Focal intense brief transcutaneous electric nerve stimulation for treatment of radicular and post thoracotomy pain. *Arch Phys Med Rehabil* 2001; 82: 262–64.
- [35] Kathleen A. Sluka and Deirdre Walsh. Transcutaneous Electrical Nerve Stimulation: Basic Science Mechanisms and Clinical Effectiveness. *The Journal of Pain*, Vol 4, No 3 (April), 2003: pp 109-121
- [36] Kolen et al., LOCAL APPLICATION MICROPROCESSOR BASED NERVE AND MUSCLE STIMULATOR. Sep. 27, 1994.
- [37] Eraker et al., PROGRAMMABLE PAIN REDUCTION DEVICE. Dec. 9, 2003.
- [38] Gunter et al., INTERACTIVE TRANSCUTANEOUS ELECTRICAL NERVE STIMULATION DEVICE. Nov. 29, 2007.
- [39] HeeJoon Park, et al., “Design and Implementation of Wireless Transcutaneous Electrical Nerve Stimulator (TNES) for Smart Phone” *IEICE Electronics Express*, Vol.6, No 22, 1587-1594, November 5, 2009.
- [40] <http://www.mikroe.com/chapters/view/16/>[Retrieved May 8, 2015]
- [41] <http://www.mikroe.com/chapters/view/16/>[Retrieved May 8, 2015]
- [42] <http://www.atmel.com/products/microcontrollers/avr/>[Retrieved May 8, 2015]
- [43] <http://www.atmel.com/products/microcontrollers/avr/>[Retrieved May 8, 2015]

[44] Mohannad Rawashdeh, RF 315/433 MHz Transmitter- receiver Module and Arduion, October 3, 2013. [<http://www.instructables.com/id/RF-315433-MHz-Transmitter-receiver-Module-and-Ardu/>] [Retrieved May 8, 2015]