

**Addis Ababa University**  
**School of Graduate Studies**

The social burden of podoconiosis in Wolayita zone, Southern Nation  
Nationality People's Region, Ethiopia

BY Ewenat G/Hanna

A thesis submitted to the School of graduate studies of Addis  
Ababa University in partial fulfillment of the requirement for the  
degree of master in public health

2005

Addis Ababa

**Addis Ababa University**  
**School of Graduate Studies**

The social burden of podoconiosis in Wolayita zone, Southern Nation  
Nationality People's Region, Ethiopia

BY Ewenat G/Hanna

A thesis submitted to the School of graduate studies of Addis Ababa  
University in partial fulfillment of the requirement for the degree of master  
in public health

Advisors- Dr. Gail Davey MD, Mph

Professor Yemane Berhane MD, Mph, Phd

2005

Addis Ababa

*Dedicated to podoconiosis affected families*

**Acknowledgment**

I would like to forward my appreciation for my advisors Dr. Gail Davey who has assisted me in the quantitative work and Professor Yemane Berhane who has helped me through out the qualitative work.

I would also like to thank the Mossy Foot Treatment and Prevention Association in Sodo, who have given their assistance in locating cases.

The Wolayita zonal health bureau has provided health professionals for data collection.

Finally I would like to thank all the participants and data collectors of the study

This project was funded by the association of physician of Great Britain and Ireland.

## Table of contents

Acknowledgment.....	i
List of contents.....	ii
List of figures.....	iv
List of abbreviations.....	v
Summary.....	vi
Section: 1. Introduction.....	1
Section: 2 Literature review.....	3
Section: 3. Objective.....	8
Section: 4. Methods.....	9
4.1 Study design.....	9
4.2 Study area.....	9
4.3 Study population.....	10
4.4 qualitative study	
4.4.1 Sample size.....	10
4.4.2 Sampling technique.....	11
4.4.3 Data collection.....	11
4.4.4 Data analysis.....	13
4.5 quantitative study	
4.5.1 Sample size.....	14
4.5.2 Sampling technique.....	14
4.5.3 Data collection.....	15

4.5.4 Data analysis.....	16
4.6 strength and limitation.....	16
4.7 Ethical consideration. ....	18
4.8 Definition of terms.....	18
Section: 5. Results	
5.1Characteristic of the study area.....	19
5.2 Belief on cause.....	19
5.3 Belief on treatment.....	21
5.4 prevention.....	24
5.5 Stigma and discrimination associated with podoconiosis	
5.5.1 marriage and podoconiosis.....	25
5.5.2 social events and podoconiosis.....	27
5.5.3 podoconiosis and education.....	29
5.5.4 podoconiosis and leadership.....	31
5.5.5 podoconiosis and health professionals.....	34
5.6 Familial tendency of podoconiosis.....	35
Section: 6.Discussion.....	38
Section: 7 Conclusion.....	43
Section: 8 Recommendation.....	44
Reference.....	45
Annex I interview guide questions.....	49
Annex II questionnaire.....	50

List of figure	page
Figure 1: the role of stigma and discrimination on the life of podoconiosis patient.....	34
Figure 2: pedigrees of podoconiosis affected family, Wollaita zone, south Ethiopia.....	37

## **LIST OF ABBRIVATION**

MFTPA- mossy foot treatment and prevention association

OPD- out patient department

SNNPR- Southern Nation and Nationalities People's Region

## **Summary**

Wollaita zone is found in the Southern Nation Nationalities People's Region. It has an estimated population of about 1.5 million out of which 92.2% lives in the rural area mainly on farming. A study was conducted in the zone on podoconiosis patients to investigate the social burden of the disease. In depth interviews were used to gain information on the social aspect of the disease. Additional quantitative data was collected on 60 families to see if there is any familial occurrence contributing to the social burden. Data analysis was performed in the field and after completion of data collection. Podoconiosis patients suffer from social burdens apart from the physical burden through out their life due to the societal values attached to the disease. Patients are stigmatized and isolated in the society. The negative attitudes towards their illness is expressed during marriage arrangements, employment, schooling and social disagreements. The disabilities of podoconiosis patients supplemented by the negative social attitude make patients less competent and productive. Podoconiosis has familial occurrence making few families targets for the stigma and discrimination found with in the society. Additionally the lack of knowledge of the cause, prevention and treatment of the disease among health professionals has added to the existing burden of the society. The course of stigma that is seen on podoconiosis patients could apply to other stigmatized diseases. Recommendation is made to raise the awareness of health professionals and the community so that the disease can be prevented as well as eradicated in Welayita and other Ethiopian societies.

## **SECTION: 1 Introduction**

Podoconiosis is a chronic disease characterized by the development of persistent swelling of plantar foot initially; which progresses to the dorsal foot and lower leg slowly or in a number of acute episodes to reach the knee. Finally the disease may end up in a permanent feature of elephantiasis of varying degree. The disease is common in families of barefooted agriculturalists of tropical Africa (1).

Local residents have their own belief about the causes of podoconiosis. Soil has been identified as the primary etiology by local residents in endemic area (1) studies done on elephantiasis mainly caused by filariasis identified spiritual and supernatural causes, hereditary factors, trauma & accident to be the causes of elephantiasis (2,3).

The investigator during her practice in Gamo Gofa zone, which is adjacent to Welayita zone, has noticed that people affected with podoconiosis associate the cause of their illness with witchcraft, evil spirit and heredity.

The peculiar physical appearance and familial occurrence of the disease has caused social stigma and isolation to sufferers and their families in different societies. They face difficulties in marriage arrangements, employment leadership, schooling and their social interaction (1,2,3).

Different authors have observed the familial tendency of the disease in their studies. A study was done to identify if the disease has a hereditary tendency apart from environmental interaction and it revealed there might be a possibility of hereditary factors (4). The familial occurrence of the disease victimizes specific families within a community by directing stigmas and discriminations towards them.

Welayita is one of the affected areas in south Ethiopia. Most of the population of the area is from the Welayita ethnic group. The area is densely populated with 290-people/square km. The economic base for most of population is agriculture, which allows prolonged contact with the local soil.

The area is known for the presence of podoconiosis for a long time. Most of the studies on podoconiosis in Ethiopia were done in this area. According to the most recent prevalence survey, which was done in the zone in 2001, it is estimated that there are about 80,000 podoconiosis patients in Welayita (5).

Although the social consequences of the disease are indicated at different times, there is no concrete evidence that fully describe the problem to attract the attention of responsible parties.

Even if podoconiosis is a preventable disease by simply wearing a protective shoe, it can be said that it is a neglected public health problem by the Minister of Health, the regional health bureau and even by the World Health Organization.

Hence the objective of this study is to investigate the social consequence of the disease and the possibility of familial occurrence of the disease that may contribute to the possible social consequences.

## **SECTION: 2 Literature review**

Podoconiosis is known since 10AD with different name and description. The disease was most reported by travelers that there is unusual type of people in Abyssinia. Monokuli (one legged) and sciopodes (shadow feet) are few of the names given for the people with the condition (1).

El Razi described the clinical feature of the disease as far as 10AD. In 1784 Handy named the disease 'the glandular disease of the Barbados' and he gave the idea that the disease could be lymphatic in origin. Later on in 1806 the work of Alder concluded that the disease is in the lymphatic vessel. The elephantiasis was explained by filariasis in 1878 but monographs in 1885 and 1886 identified that there are filarial and non-filarial types of elephantiasis (1).

The real cause of the disease was not identified till recently. Cohen called it idiopathic lymphoedema in 1960 in his study of the condition in Ethiopia and Kenya to identify the cause (6).

In east Africa high prevalence of podoconiosis extends from Ethiopia to Tanzania. It is also found in parts of West Africa, in Latin America from Mexico to Colombia & Ecuador, and in Asia in India & Sri Lanka (1,7)

The prevalence of podoconiosis was studied in Ethiopia at different time. A market count by Oomen in 1969 at 56 randomly selected places throughout the country revealed a prevalence of 2.72% among over 15 years of age population. A national house-to-house survey conducted by Price at the same time of

Oomen's market count during malarial eradication service revealed a prevalence of 3.48% throughout Ethiopia (8). A survey done in attempt to establish the relationship of podoconiosis with red soil, a market count in the former Sodo-Wollamo currently Welayita zone has revealed a prevalence of 5.38% on average (9). Price in his national prevalence study from 1969-1973 has shown that podoconiosis is found in many places in Ethiopia. He noted that in few places the prevalence is as high as 5-10%. This was explained due to migration of patients to cities for begging. This study has shown that an estimated 200,000- 350,000 people, out of the then 23 million total population, were affected by podoconiosis in the country (10). Wollamo district was one of the areas with high prevalence of podoconiosis. Price in 1973 had made a market count and found that the prevalence of podoconiosis among over 15 years population ranged from 4.29- 6.92 in five villages of the district (11). Similarly a recent survey conducted in 2001 in Welayita zone revealed a prevalence of 5.46 % ranging from 4.04- 6.85 in different woredas of the zone (5).

Several studies done to find the cause of elephantiasis in Ethiopia have failed to show infectious cause, indicating the high probability of podoconiosis. The elephantiasis in Ocholo, (south Ethiopia), where leishmaniasis is common, elephantiasis was not associated with leishmaniasis (12). A clinico - epidemiological study done on filariasis revealed that filarial patients do not have elephantiasis of the lower leg in some parts of Ethiopia (1, 13)

Studies confirmed that red clay soil of endemic area that is rich in fine particles (mostly <10micrometer) of silica and almunosilicates play a significant role in the pathogenesis (11, 14, 15). That is why podoconiosis is limited to some countries owing to the geographical effect of disease distribution (16). In fact podoconiosis could be easily prevented and eradicated by simply wearing shoes (11,17).

In the past two decades there is an increased suggestion of hereditary factors in the susceptibility of a disease due to the familial occurrence of podoconiosis (18, 19). A pedigree analysis done in 1972 by Price E.W. on patients identified from a clinic in Addis Ababa has suggested a possibility of familial occurrence of the disease (20). Similarly familial occurrence has been noted on patients in Ocholo (12).

Local residents have their own belief about the causes of podoconiosis. Soil has been identified as the primary etiology by local residents in endemic areas (1). Studies done on elephantiasis mainly caused by filariasis identified different beliefs by the local residents in different countries. Most of them attribute it to spiritual and supernatural causes (2,3). A study done in Ghana and Haiti showed that in addition to the above causes elephantiasis is believed to be caused by hereditary factors, because it occurs in some families across generation (3). In the same way the Haitian believes that spiritual& supernatural causes, trauma & accident to be the main causes of elephantiasis (2).

Goffman described stigma as a powerful discrediting and tainting social label that radically changes the way individuals view themselves and are viewed as persons. Alonzo and Reynolds described stigmatized people as follows:

*"The stigmatized are a category of people who are pejoratively regarded by the broader society and who are devalued, shunned, or otherwise lessened in their life chances and in access to humanizing benefits of free and unfettered social intercourse" (21)* Stigma towards a specific condition occurs due to the societal values attached to it. The belief of the cause of the disease and disability are some of the factors that lead to stigma. Discrimination is an action taken by the society based on the existing stigma (22, 23).

Price described the presence of stigma associated with leprosy at work places, in school and during marriage arrangements (1). The peculiar appearance of elephantiasis patients has caused social stigma and painful remarks to the sufferers and their families in Haiti and India (2,3). In Ghana a patient with elephantiasis is denied the role of leadership if he has the disease before getting the chance. Patients have also difficulty in engaging in a marital relationship. This is because elephantiasis patients are unattractive, less productive and needs extra care during acute attacks (2,3, 17). Apart from this the familial occurrence of the disease may victimize specific families with in a community by directing stigmas and discriminations towards them.

One of the solutions to relive stigma is the involvement of health professionals. Having help from a health professional will give stigmatized patients more confidence and allows them to avert their felling of inferiority. They will perceive that their illness can be helped and they will accept their difference from other people is a random occurrence that can happen to any one (21).

## **SECTION: 3 OBJECTIVE OF THE STUDY**

### **3.1 GENERAL OBJECTIVE**

To assess the social burdens of podoconiosis and the familial tendency of the disease that may contribute to the social burden

### **3.2 SPECIFIC OBJECTIVE**

- To identify belief about the cause of podoconiosis.
- To identify stigma and discrimination associated with podoconiosis.
- To assess the familial occurrence of podoconiosis.

## **SECTION: 4 METHODS**

### **4.1 STUDY DESIGN**

The study utilizes a qualitative method involving key informant in-depth interviews and a quantitative method that uses a structured questionnaire to explore information on the pedigree of podoconiosis affected families.

### **4.2 STUDY AREA**

The study was conducted in Welayita zone, which is located in the Southern Nation Nationalities and People's Region (SNNPR). The capital of the zone, Sodo, is about 380 km from Addis Ababa. The zone is divided into seven administrative woredas. A total of 274 peasant associations and 20 urban dwellers associations are found in the zone. 89.58 % of the population lives in the altitude of 1500 and above. It has an estimated population of 1,567,561 as of 2004(projected from the 1994 censuses) (24, 25). Out of the total population 92.2% live in the rural area mainly on farming and the remaining 7.8% live in the urban area. The study area was chosen because the most recent prevalence survey done in the area showed the public health importance of the condition in the zone (5)

Mossy Foot Treatment and Prevention Association (MFTPA) is a local non-governmental organization, which is found in Welayita zone. The objective of MFTPA is to identify podoconiosis patients within the community and to give supportive

treatment and educate patients on the cause, prevention and treatment of the disease. It gives health education on how to keep foot hygienic and what parents should do to non-affected families so that they will not get the disease. For patients with advanced disease the association provides corrective surgery. In addition it also provides patients with low cost shoes, which helps to arrest the progress of the disease. Donors like the British Embassy support the association. All the treatments provided by the association are with subsidized costs.

### **4.3 STUDY POPULATION**

The ethnicity of most of the population in Welayita Zone is Welayita. The remaining are composed of different ethnic groups mainly from the adjacent zones like Hadia, Kembata and Gamo. Out of the seven Woredas Sodo Zuria, Damot Gale, Humbo, and Boloso Sore were included in the study considering their access for transportation.

### **4.4 QUALITATIVE STUDY**

#### **4.4.1 SAMPLE SIZE**

The sample size for the qualitative study was not decided at the beginning. It was decided in the field based on how much the research question is answered. Saturation and redundancy of information has set the limit to the number of interviews.

#### **4.4.2 SAMPLING TECHNIQUE**

Heterogeneous method was used to find key informants from different occupation, disease status and sex. The translator and Kebele administrative office have helped in locating individuals in different kebeles.

Informants were contacted in the school, in the health center, at their home and at their work places. The guide questions were fine-tuned based on the informants' occupation, disease status and sex.

Participants were from different disease status, occupation and sex. A categories participating in the study included patients, healthy individuals without patient families, students, health professionals and traditional healers Most of the study participants were from the rural areas where most of the population resides.

#### **4.4.3 DATA COLLECTION**

In-depth interview were the methods for qualitative data collection. The interviews were conducted using pre-established guideline. In-depth interviews were conducted to obtain information on the belief of the society and stigma and discrimination towards podoconiosis. It was a one to one interview in the presence of a translator and when the patient chooses in the presence of other family member for their own comfort. When respondents were able to speak Amharic the interviews were conducted in Amharic but the participants were given the right to choose the

language of medium either to be Amharic or Welayitigna. Although all the interviews were done following the preset guideline participants were encouraged to actively participate and guide the flow of interview. The main role of the investigator apart from asking the questions was mainly to listen and take field note in a way that doesn't distract the attention of the interviewee.

Most of the Interviews were done in the house of the respondent. Some of the interviews done with that of health professionals and students and some employed participants were done in their respective work places. The entire interviews were done in a situation where the privacy of the participant is kept. Interviewing students in schools has helped to explore better information that could not be found if they were interviewed in front of their families in which case students tend to be shy and less informant.

All of the interviews with in the community were done during the morning, usually before 10A.M, where every one will be inside for a morning coffee. The one to be interviewed is taken to the back yard so that he/she will be comfortable. The interviews among health professionals were done during the afternoon, where OPDs are less busy and those in the out reach EPI sites come back to the health center.

Open-ended questions were used to collect relevant information. The guideline was tailored based on the interviewee's occupation, disease status and sex. This helped to address the relevant issue to the appropriate person.

Only one interview was done per day so that listening the tape immediately after the

interviews enriched field notes. Preliminary analysis was done during the afternoons and the evenings. This helped to identify and remove saturated questions and add a new one for the next day.

The questions are set to identify the belief of the society towards podocniosis and stigma and discrimination associated with it. The interview starts with a more general question and then moves to a more specific one.

All of the interviews were tape recorded with the permission of the participants. Some pictures of patients were also taken at the end of interviews whenever participants are willing.

#### **4.4.4 DATA ANALYSIS**

During the afternoons the field notes are enriched using the tape-recorded information. Preliminary analysis was done manually after each interview so that the outcomes of the interviews were outlined.

The interviews that were conducted using a translator were transcribed and data clearance, by repeatedly listening and re-reading, for them was done using a translator in the field.

Observations done as part of the interviews were incorporated during the transcription of the interviews for further analysis.

After complete transcription and translation of the interviews data clearance was done by listening and re-reading the interviews repeatedly. The cleared data was entered on to Open Code computer software for qualitative data

## 4.5 QUANTITATIVE STUDY

### 4.5.1 SAMPLE SIZE

For the pedigree analysis sample size is calculated with the statistical formula used to calculate sample size for case only designs in genetic studies to detect gene-environment interaction. For simplicity reason the following assumptions were made

- The genetic prevalence for a rare autosomal recessive disease =  $p^2$ , where  $p$  = susceptibility allele frequency within the population (26). From the study by Price E.W, the average gene frequency was 0.3 thus the prevalence of allele is 0.09~0.1(20).
- We assume that the disease risk is increased only in the presence of genotype & exposure. Hence  $R_g$  (risk of genotype) &  $R_e$  (risk of exposure) are equal (there is type one interaction) (18, 19)
- From the previous prevalence study there is high prevalence of bare footedness, which ranges from 73.9-98.7%. It is assumed that this will be equivalent to exposure to red clay soil (5, 9).

With the above assumptions, at significant level of 5% & power of 80% the sample size is 54 families from the sampling table for genetic studies prepared by Quanhe and his colleagues (18). Adding a 10% contingency the total sample size will be 60 families.

### 4.5.2 SAMPLING TECHNIQUE

Families with two or more affected sibs are included for the family study of the

disease. The lists of patients in the selected woredas have been obtained from MFTPA, which is based in Sodo, with with special assistant from the treatment coordinators and treatment site workers. Those with two or more affected sibs in the family were enrolled randomly in the study. Once the name of probands is obtained from the list, kebele administrator and local residents helped to indicate the proband's house. At the time of data collection only those probands with real bloodline have been included in the study. The head of the house hold was selected to provide information on the present and previous ancestors with in the family.

#### **4.5.3 DATA COLLECTION**

Quantitative methods were used to assess the possibility of heritability of the disease. Family history of the disease and factors like habit of wearing shoes, age onset of the diseases and age at death for ancestors that are not alive was taken across different generation of probands using structured questionnaire.

The study design was chosen for two reasons. The first is to satisfy the study objective that is to assess the familial occurrence of the disease and the second is to identify the suitable design for the future if laboratory based study is going to be done.

Three Interviewers, two diploma nurses and one health officer; fluent in Welayitigna and familiar with the local custom; who have experience working with podoconiosis patients at the Sodo hospital MFTPA site and who are physically fit to work in the field were recruited and trained to collect data.

Apart from the principal investigator a health officer who is conversant with the local language was selected as a supervisor. He was responsible for monitoring the data collection process in the field.

Training was given for the interviewers and the supervisor for three days prior to pretesting and for a day after pretest. The training included the brief objective of the study, about the content of the questionnaire in detail and how to administrate it in the field. It was given in the form of discussion, demonstration and role-play.

The principal investigator and the supervisor rechecked 20% of the questionnaires, to see if the interviewers were doing their job correctly. The supervisor went to the field every day with the data collectors and the investigator went together with the data collectors to some families.

#### **4.5.4 DATA ANALYSIS**

After collecting information across different generation the information were entered on Microsoft Excel for analysis due to lack of genetic softwares. Analysis was done on the prevalence with in the families and habit of shoe use. The findings were compared with the general population.

#### **4.6 Strength and limitation**

##### **Strengths**

The study design was appropriate to explore the beliefs of the society and stigma and discrimination towards podoconiosis, which is less understood previously.

The investigator has tried to learn the basics of the local language such as greetings, blessings, sympathies, insults and others in advance of the interviews. The investigator ate and drunk local foods with participants. This helped to ease the flow of communication and created trust between the investigator and participants.

Most of the interviews have taken place in or around their house as per their own choice. This helped to keep the privacy of participants and helped them to be comfortable during interviews. In case of participants who couldn't speak Amharic a local translator was used.

### **Limitations**

The cultural gaps between the investigator and the participants have an impact on the responses. The investigator tried to solve this problem by using a native translator. Translators tend to summarize the answers of the respondents. This may have resulted in missing important information from the interviews. Even though preliminary training was given for the translator the problem couldn't be avoided completely.

The investigator has come across patients who deny their condition even when it is too obvious to hide it. Because of this the investigator expects a high number of false negatives especially in probing family history of the disease. In addition early stage of the disease could be missed because there is no physical examination done to identify cases.

## **4.7 ETHICAL CONSIDERATIONS**

Informed consent was given orally before each interview and sample collection. The participants were told the purpose of the study and only those who were willing to participate have been included in the study.

At the end of each interview health education was given about the cause, prevention and the locally available treatment of the disease for both patients and healthy individuals. For patients additional hygiene education was given and they were provided with soap.

## **4.8 DEFINITION OF TERMES**

**DORSAL FOOT-** the part of the foot opposite to the sole

**PEDIGREE-** a chart that contains the list of an individual ancestor across different generations

**PLANTAR FOOT-** the sole of the foot

**PROBAND-** is the person whose phenotype led to recognition that a particular trait is present in a family; the first person in a family to be identified as having a trait and thereby calling attention to the family. Other terms with identical meaning are *index case* and *proposit (us/a)*.

## **SECTION: 5 Results**

### **5.1 Characteristics of the study area**

A total of 22 interviews have been done between October and December 2004 in Welayita zone. The interviews are done on both sex with different health status (podoconiosis affected or not), occupation and place of residence. The age of respondents ranges from late teenage to more than 60 years.

The respondents were composed of literate and illiterate individuals from different professionals and social roles. 14 of the interviews were conducted in Amharic while 8 of them were done in Welayitigna with the help of a translator. Observations on gestures, facial expression and state of emotion were noted as part of interviews.

### **5.2 Belief on Cause**

Podoconiosis is a well known disease in the Welayita society. The local vernacular given for the disease is 'kita' which means swollen indicating the physical appearance of the disease. The name given for the disease is one of the worst insults in the locality.

The community perceives that the causes of the disease are multiple including supernatural, spiritual, biological and physical. The most common cause identified by respondents was hereditary. Some strongly suggested the disease to be strictly genetic while some describe that even if genetic predisposition is critical it could be caused sometimes by some other factors. The strong belief of the cause of the

disease to be genetic is reflected during marriage arrangements and social disagreements, which result in exchange of hot words. One healthy middle-aged man described the cause of the disease as follows:

*' Kita is a disease mostly associated with heredity. For example if the mother or the father have the disease the child or the grand child will have the disease too. It is a sort of inheritance.'*

And he describes how people threaten families of patients during fights by mentioning the presence of the condition in the family.

*" During fights and disagreements they (healthy individuals of patient families) are said ' your brother/father is swollen. I know you! How could you speak to others like this? Your families are swollen.' "*

The second most frequent reason given to be the cause of the disease is walking on dead snakes and other small animals like frog. It is believed that snakes have poison that make the foot to swell even if after they are dead. Most of the respondents who gave dead snakes as a reason for podoconiosis associate the events with going out in to the forest. One podoconiosis patient has expressed the cause of her illness as follows:

*'It starts when I was a small child. People tell me that I got snakebite when we were mowing grass. I got treatment for snakebite but I didn't get well.'*

Cold weather and accident are also mentioned frequently to be the cause of the podoconiosis. People strongly associate cold wheather with recurrent attacks. A middle-aged man who is a farmer and a weaver has described his cause of illness to

be associated with the morning cold and repeated accident:

*" During the morning I walk on cold earth, during a night I walk on dew, I work in the dust and I had frequent accidents. We live on farming, we work in the soil, we get up early in the morning and we get the cold."*

The society also believes that direct contact with the patients such as sleeping together and sharing footwear, and indirect contacts such as having accident with sharps like needle that have been used by patients and fly to transmit the disease.

According to the society spiritual and supernatural forces could cause the disease.

This could be caused either as a punishment for not treating patients appropriately or due to the act of sorcery that is performed to hurt a fortunate person. If someone is rich and physically attractive then s/he is prone to evil eye and may get the disease.

One podoconiosis affected student was telling the event which costs her foot as follows:

*" In 1986E.C my grand mother died. At that time our family was famous and rich. I was playing with my friends when I stepped on egg, frog meat and blood stained piece of clothe rolled together thinking it was our ball. Then my feet become very itchy. I tried to think what it could be. My foot started to swell as days pass. Finally I developed the lesion."*

Participants also mentioned that worms from the soil may enter the foot and cause the disease.

### **5.3 Belief on treatment**

Podoconiosis patients seem not to have range of options for the treatment of their

condition. The most agreeable option for the treatment of the disease is the Mossy Foot Treatment and Prevention Association Treatment Site, which is a relatively new project in the area.

Traditional treatment which is most used by the society for other conditions is not helpful for these patients. They do not even seek treatment from traditional healers knowing that they don't get any solution from any of them. Of course some of the patients visit holy waters and herbal treatments but for a very short session. They will shift to modern medical care, mostly the one given by MFTPA treatment site or else they will never seek treatment. An elderly patient was asked if there is any traditional treatment for her illness. She answered in a louder voice saying

*" There is no traditional medicine here! Nobody knows a medicine for this disease. People tell me to go to a health institution to get shoes. But what I do when I feel worst is wash with soap and salty warm water."*

Even the traditional healers do not suggest having any remedy for the condition. One traditional healer was asked if she could treat podocniosis and the answer she gave was:

*" Except in Otona (the Sodo hospital), there is no medicine. They can be treated in the hospital. I have my nephew who used to have the disease. I took him to Otona. He got the treatment and he is okay now."*

The 'coffee', which is prepared in the locality using coffee tree leaf and spices like garlic, black cumin, rue, lemon grass and sacred basil is used during attacks to

relieve pain. Patients claim the 'coffee' to be a good painkiller especially to relieve the cramps they encounter during cloudy days. When a man was asked if the 'coffee' is helpful he responded in a way of indicating the temporary use of the remedy:

*" What do you mean? It is good! When they drink these spices the cramp will leave them for sometimes. Then they will be sick in 15 days. For example if I am sick today I know that I will be sick again in 15 days. It is recurrent and the patient will expect the recurrent attack in bed."*

Most patients have at least heard about the MFTPA treatment site although they do not have the exact information of what is done there. Except for those frequent users patients do not know the schedule and purpose of the treatment site. The frequent users are most of the time satisfied with the outcome of the treatment given for them by the treatment site. They have seen an improvement and that helped them to improve their social activities. Visiting the treatment site has given them an insight on the cause of their illness and those patients are found to be better aware of the cause and prevention of their disease.

The chronic nature of the disease has made patients hopeless to seek treatment. They have accepted the condition to be incurable which is actually a fact and untreatable at all. When a podocosis affected girl was asked if she is getting treatment, she expressed her lack of satisfaction with the treatment:

*" I don't follow the treatment because I didn't see any change "*

Although it is known that the disease is incurable and there is limited treatment to it patients have highly positive health seeking behavior. Their strong demand for

'injection' in which they believe to be a solution for their illness contradicts with their trust on the traditional treatment. This shows that they have more expectation from the modern treatment.

Most of the participants believe that having 'injection' is helpful to treat the disease, although they do not mention the type of 'injection'. Most of the time patients seek 'injection' from illegal medical practitioners in the village. These are either low level health professionals or non- professionals. Even if they complain the cost to be very expensive, still they go to the practitioners seeking some help. This expresses the willingness to pay for medical care among patients.

#### **5.4 Prevention**

The strong belief of the disease to be hereditary has made people to think that the disease is unpreventable. According to the society the best method to prevent the disease from appearing is to avoid marriage with those who have patients in their family. Otherwise if the condition is found within the family only the lucky one will escape from having the disease. The other way of preventing the disease is to avoid events that may predispose to acquiring the disease. Some of these are going in to the forest, stepping on evil spirited items and direct and indirect contact with patients. A man expressed the preventability of the condition by saying:

*' it cannot be prevented with any miracles. If it is found in the family there is no way of preventing it. As a chance some may not develop the disease. Not everybody gets the disease. For example if the mother has the disease they will expect the healthy*

*child to develop the disease if marriage happens with out knowing the podoconiosis status of the family, the disease may appear on the 3rd or the 4th generation. When podoconiosis is seen couples start investigating each other's families. They will ask ' is that in your family or in my family?'"*

Participants have mentioned shoes frequently but the purpose was to hide their foot from others. Some mention shoes to be useful to prevent frequent attacks and accidents that may aggravate the disease. Few participants from the MFTPA treatment site suggest that having shoes from childhood is protective. One patient who receives treatment from MFTPA answered the question, what he would do to his child in the future so that he won't get podoconiosis, by saying:

*'Shoes protects from danger in all seasons. It protects from the cold, the sun and the wind. He may go to the forest for shepherding. As I told you previously in the forest there are worms that may cause the disease. I will not let my child to go in to the forest. If he has to go I will let him put on his shoes. If I keep my child like this he won't get the disease.'*

## **5.5 Stigma and discrimination associated with podoconiosis**

### **5.5.1 Marriage and podoconiosis**

One of the difficulties of podoconiosis patients is during marriage arrangements. Due to the strong belief of the society that the disease is hereditary willingness to marry podoconiosis patients is nil. When a healthy woman was asked whether she will be

willing if a patient asks her daughter for marriage she answered by saying:

*" She wouldn't be willing in the first place"*

When another podoconiosis affected man was asked if he would be willing to give his patient daughter for marriage for a healthy man he said:

*' A healthy man wouldn't ask my daughter for marriage because she is a patient.'*

When he was asked why? he said with a solemn voice:

*' If a healthy man wants to marry a patient his families will look down on her. They will say ' How could he marry this girl' and they will look down on her.'*

The problem with marriage is not only limited to the patients themselves. It is also reflected on patient families. This is expressed by the way people dig into the family history for the evidence of podoconiosis before any marriage arrangement. One participant described his experience as follows

*'there was a girl in my village. Her father and uncle have the disease. She was very beautiful. She fell in love with boy and they decided to get married. The father of the boy was not around. When he came back he heard about what is going to happen. He threatened his son to kill and to cut him off the family. Others tried to argue with him but he had his own reason. He was saying ' My son is going to spoil our heredity' and his son didn't marry the girl.'*

No matter healthy he/she is during marriage the family history of podoconiosis matters more than anything. A man was asked if a rich podoconiosis patient would marry a healthy girl. What he has said was:

*' Why not be a millionaire? He wouldn't marry. He will look for his mate from the*

swollen.'

### **5.5.2 Social events and podocniosis**

Welayita society has strong social norms. The society sticks together during day-to-day activities. The social events like funerals, weddings and market are the measures of social acceptability in the society. Who will be together during social events is determined by the social position of individuals in the society. podocniosis patients are treated differently during such occasions. They are isolated from the rest of attendants. They are given a separate seat and they are served food in isolation. Their plates will be taken care of separately so that the disease is not going to be transmitted to others. A man was expressing the role of patients in the social life:

*" First of all there is a status for social life. Social relations are made between healthy individuals not with someone poor and crippled. Even if they wanted to do it the society would not allow them. Because nobody will give them place in the social life, don't consider them as a human being and they are seen inferiorly they don't have a chance other than being sorry of their bad luck. They live their life wishing their death. They say ' God why don't you kill me?'*

This differential treatment of patients is strongly associated with the stage of disease the patient have. Those with early stage and mild disease are more comfortable as compared to those with severe and advanced disease. This is because those with the early stage can conceal their condition. A nurse described the association of the

stage of disease with social isolation as follows:

*" The isolation is not at the onset of the disease. At the onset the patient will hide himself as much as possible. It is like being pregnant out of wedlock. At first she may hide it with clothes but finally it would come to the stage where she can't hide it. Similarly they hide themselves initially but when the disease advances and they develop super infection and others will complain."*

Apart from the isolation of patients by the society, they also isolate themselves. This is to avoid painful remarks and comments forwarded by others towards them. This may be due to the bad experience of patients in the past or the experience they see on other patients. A healthy man describes how patients isolate themselves in the society:

*"Before a healthy person says a thing they will isolate themselves. They believe that the healthy people will look down on them. They don't even speak about their illness openly."*

The isolation has an impact on the social performance and their psychology. This is reflected on how they deal with others by self-isolation during social events and in school. One student was asked why he doesn't want to have friends in school. He explained his reason in a distant voice:

*" The healthy do not have good attitude for patients. They may say nice things when*

*they are with you but they circulate gossip at the back. If I hear bad things I don't have the capacity to fight with them. I am a patient. Am I going to fight with some one who initiated the gossip? I isolate my self for this reason."*

### **5.5.3 podoconiosis and education**

The severity and the frequent attacks of podoconiosis have an impact on the school performance of patient students. Students are obliged to miss classes and even to drop out of school for a year and more due to their illness. One student who has been out of school for four years described her experience like this.

*" I have been out of school for four years because of my illness. One year I went to holy water in Boreda (a small village), last year I got sick, when I was in grade 8 during the national exam I have been out of school and also when I was in grade 6 I was out of school"*

The reaction of other students in the classroom whenever patients have difficulties with their legs during attacks, which is mostly associated with bad smell, have contributed to the low performance of students and has caused some of the students to drop out of school. A girl has expressed her desire of going back to school. She remembers why she has dropped out of school in the first place. It was the reaction of students in her classroom that drove her out.

*"My foot used to have a very bad smell. It has also a watery discharge. At that time they say "your foot is very stinky go out!" I stopped school when I was grade 8. They*

*say, "It stinks go out!" I thought I was not going to succeed like that and I dropped out of school."*

The things that are found outside of school; the perception of the society to patients has made students to be hopeless in their education. One of the health professionals was amused on how one female patient could have qualified for collage when he was in the nursing school

*" You know you don't go to campus as you wish. You have to pass a lot of things to be in college. Our teachers were complaining on how she could have passed the criteria of being healthy"*

Podoconiosis affected students are perceived to be unsuccessful and they are taken as a reference for bad performance. One healthy man was telling how patients are treated by their healthy collogues in the school

*" They are insulted. They call them 'swollen '. There is a tendency of looking down on them. If they come on top in the class they will say 'this twisted has answered this question. How comes you don't answer anything?' 'This swollen foot has got10/10. How could you miss?' and such other things are said. There is a tendency of looking down them among students."*

#### 5.5.4 podoconiosis and leadership

Although patients are members of different social activities they don't have equal representation in events. In 'idirs' where everyone is a candidate for leadership patients are less likely to serve as leaders. This is because of the physical and financial position of patients in the society. A man was asked if a patient could be a leader in an 'idir'. What he has to say was:

*" May be if he is very rich, if he has big farm and a lot of money. If he is poor and a patient at the same time he won't be a chairperson. He is not even needed as a witness. Nobody will go to him."*

The other problem is healthy people are not willing to elect patients as leaders taking the disease into consideration. A patient expressed his desire of serving as a leader with solemn voice:

*" If I could I wanted to be elected but the others will think that I couldn't facilitate the work and they wouldn't elect me."*

Although patients believe that they are capable of working healthy neighbors will not take that into account. A podoconiosis affected woman was expressing the reason of not electing patients as a leader:

*" If you are elected as a chairperson, you have to go long distances in case of problems. Patients can't do that because they are not fit. They don't elect the patient*

*but still he will help them (he will do the work as a friend might do). Our people do not know such a fair election. They always elect the healthy."*

### **5.5.5 Podoconiosis and health professionals**

Although the disease is wide spread and well known in the society, health professionals from different health facilities that render service to the community have misconceptions about the cause, prevention and treatment of podoconiosis. This reflects the lack of awareness about the disease in training institutions.

All the health professionals who have participated in the study believe that the disease is infectious and is transmitted by a vector. The word 'elephantiasis' was the name used by health professionals to indicate the disease. They have mistaken the disease for filariasis, onchocerciasis, and even schistosomiasis. One public health nurse working in the OPD describes the cause of the disease in a very sure way like this:

*" As I know this elephantiasis is transmitted by mosquito, anopheles and culex. Culex transmits the disease in the urban area while anopheles transmits the disease in the rural area. The incubation period lasts from one month to a year"*

They believe that there is medical treatment for 'elephantiasis' but it is not accessible in the zone. They also suggest that to prevent the disease monitoring the vector, i.e.

mosquito, is essential. According to them vector control mechanisms that can be applied at the stage of larva or adult could avert the spread of the disease. The prevention of the disease was put by one of the health professionals like this:

*"By the way the disease is transmittable. Mosquito transmits it. If we can control the mosquito there is no reason why we can't prevent the disease. Nobody did that. We can control the disease by monitoring swampy areas, using insecticides and larvicide."*

Although health professionals believe that there should be due attention given for the disease there is no initiative to include the disease in the health education sessions of the health facilities.

In general podoconiosis is a disabling condition which affects the physical activity of patients and which cause psychological pain to sufferers and their families due to the stigma and discrimination directed towards the diseases by the society. Apart from this the familial occurrence of the disease has contributed in aggravating stigma and discrimination towards specific segment of the society. healthy individuals of patient families are affected by the stigma. The stigma towards podoconiosis patients affects the life of the sufferer in a way of vicious cycle.

Figure one below shows the role of sigma in the life of podoconiosis patients in Wollaitta zone.

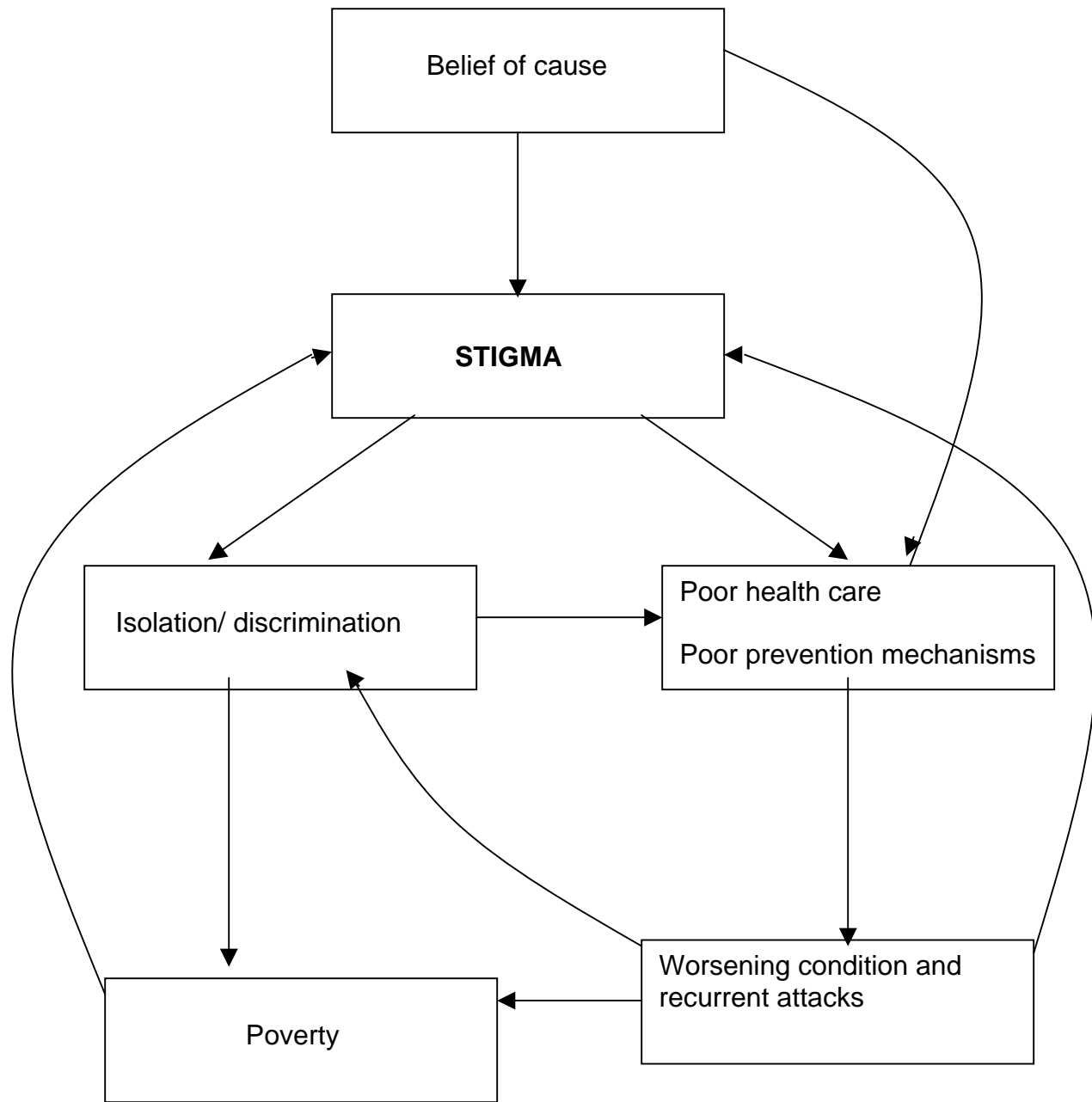

Fig. 1 the role of stigma and discrimination on the life of podocniosis patient

## **5.6 Familial tendency of podoconiosis: quantitative study**

The society strongly believe that podoconiosis is a hereditary disease and directs the stigma and discrimination towards families. This study was conducted using a structured questionnaire composed of mainly information about the family history of the disease at different generation to identify whether there is any evidence of familial occurrence of the disease.

A total of 60 families were identified to be included in the study. One family was excluded from analysis because of incomplete information. In the 59 families information was collected on 1397 individuals through different generations.

Mean (SD) family size was 23.7 (6.8) individuals, with a range from 14 to 48 family members. 25 families had data collected over 3 generations, and 34 over 4 generations. A total of 235 sib ships were recorded, with a mean (SD) six of 4.7 (2.6), and a range from 1 to 16 siblings. 19.0% of individuals whose disease status was recorded had podoconiosis, 19.4% of males and 18.5% of females (the difference was not statistically significant), and 175 affected sib pairs were identified. Figure one below illustrates an example of podoconiosis affected individuals.



Only 666 (47.6%) individuals have ever used footwear in their lifetime. This shows high exposure to environmental risk.

The risk of illness among the study participants could be an under estimation since

physical examination is not done in any of the individuals and it is found that people hide their podocniosis status to avoid the associated stigma. In addition there could be recall bias since enquiries are made on the disease status of generations that are different from respondents.

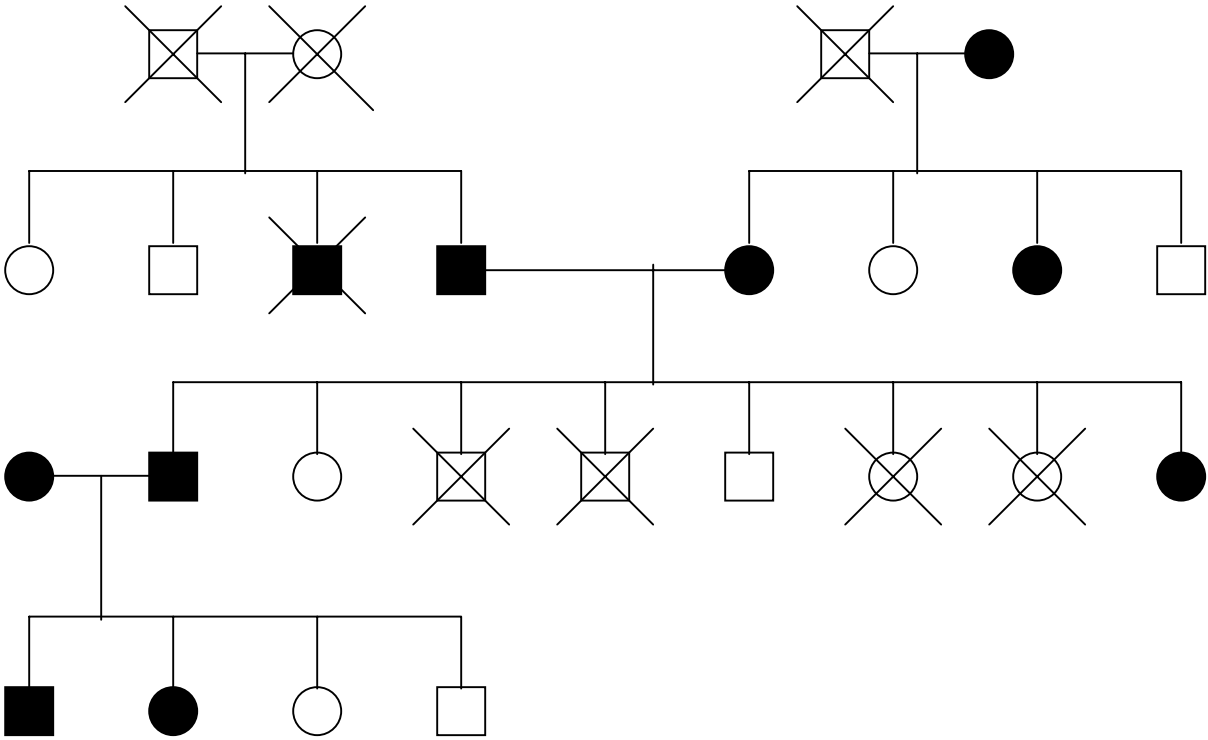
Figure 2 pedigree of podoconiosis affected family, Wollaita zone, south Ethiopia

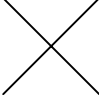

- Key-
-  - Male
  -  - Female
  -   - Affected
  -   - Unaffected
  -  - Dead

## **SECTION: 6 Discussion**

Podoconiosis is a well-recognized condition in the Welayita people. The disease has a local name that also serves as an insult, 'kita'. The name 'kita' itself, which means swollen, describes the clinical condition of the disease. In this society it is believed that the disease runs in a family. In addition they also believe that supernatural forces such as witchcraft and living things such as snakes may cause the disease. The chronic condition of the disease has caused patients to suffer from physical, social and psychological pain. Patients have limited options for treatment. Traditional healers do not suggest any kind of remedy for the illness. Patients have accepted their condition as untreatable and unpreventable and because of this they do not seek treatment most of the time. The other grave situation is the lack of knowledge among health professionals about the cause, prevention and treatment of the condition. This may have an impact in combating the disease. Patients are considered as hopeless and helpless in the society. They have also accepted this view of the society, which has an impact on their performance.

The presence of a local name for the disease shows that the disease is well understood in the society. Before the 10 A.D among Arabian travelers in Ethiopia used to say that there were specific type of people in Abyssinia who can shade themselves from the sun with their own foot (10). This is to describe the physical appearance of the disease. In fact the travelers at that time consider this patients as people with specific 'race'. In the ancient Greece there were pictures showing

podoconiosis patients shading themselves with their own foot from the sun. (1)

The fact that the society believes the cause of podoconiosis to be spiritual, supernatural and hereditary is common in chronic disabling diseases (3, 22). Such belief determines the acceptability of the affected individuals in their community. The different insults and negative attitude of the society towards podoconiosis patients are also derived from the cultural beliefs that are attached to the disease. Because of the attached stigma to the disease, mostly the belief of the cause of the disease to be hereditary, patients will try to conceal their condition as much as possible. This is why Cohen in 1959, when he was trying to identify the possibility of hereditary factors for the occurrence of podoconiosis using verbal autopsy, said:

*'It is rare to find a patient in Ethiopia who knows any one else in the same village with podoconiosis'*

The prevalence of podoconiosis was found to be more than 6% in some villages of Ethiopia later on in other studies (6, 10).

The chronic state of the disease, the belief and attached stigma in the society and lack of definitive treatment for the condition discourage podoconiosis patients from seeking treatment. This is a common situation in other stigmatized conditions (3, 22, 27). The fact that podoconiosis patients are taken as hopeless is associated with the strong belief of the society that they can't perform the required social tasks and the values attached to it. People with disability are most disadvantaged poor citizens anywhere in the world and especially in developing countries where facilities are

limited. They are denied adequate health care, education, employment and social equity, which is true in podocniosis patients. In fact podocniosis patients in Welayita have accepted the view of the society that tells them that they are unable to work and they are not socially equal. This has been observed in other disabling conditions (22). This leads patients with podocniosis to be dependent on others for most of the social and economic activities including farming which is the basic source of income in the society.

Podocniosis patients have problems in completing their education because of the push they feel from healthy individuals and the burden of their illness for which they cannot find a remedy to alivert it. Worldwide only 3% of disabled individuals are literate and it drops to 1% when it comes to women (22).

Podocniosis patients are less likely to be employed because of the unwillingness of employers to take them as employee due to the social values and beliefs that are attached to the disease and the physical condition of patients, which have an impact on their physical activities. Other studies have shown that most available job for disabled people is begging, which is a social tragedy of developing countries in which 80% of the total disabled people live (19, 22). It is noted that most of podocniosis patients in the town are beggars (10). These beggars are migrants from endemic areas in which they are pushed out of their village for reasons found in this study.

The cause of podocniosis was not understood till recently. In 1959 Cohen has done a qualitative study in Ethiopia and Kenya to rule out the possible causes for the

disease and finally called it idiopathic lymphoedema (6). After this time many scientific studies were done and the etiology of the disease was found. There were different opinions suggesting the disease to be congenital malformation or some defect with the lymph glands and vessels. Finally the disease was found to be geochemical with consecutive studies (28, 11). By the time the disease was renamed again as podoconiosis it has become a legend to some developed countries like France who used to have it in the past. This has an implication in the attention given to the disease by powerful countries in the world (1, 29)

The fact that the disease is not present in well-industrialized area has resulted in little attention for the condition. Major medical textbooks do not have any thing to say about the condition while some tropical disease texts have only few paragraphs, mainly the etiology of the disease (6).

The lack of knowledge among health professionals about the disease may be due to little or no attention given by training institutions as well as policy makers and implementers. This couldn't satisfy the health seeking behavior of podoconiosis patients in Wollaita, which is very high but who will get little or no help from health care providers even if they decided to go. Most of the few studies done on podoconiosis in Ethiopia were done in the late 1960s and early 1970s.

The fact that podoconiosis is associated with negatively valued things with in the

community and the physical appearance and endurance of patients, have placed them in a lower position within the community. This is expressed by social isolation during marriage, schooling and leadership positioning. The lack of appropriate health care services within the zone has supplemented the already existing marginalization within the community (22).

The belief of the cause of the disease to be hereditary is consistent with the finding in this study. The high prevalence of podoconiosis within the families could contribute to worsen the stigma. In addition it will direct the stigma and social isolation towards specific families within the society (8). Price indicated the familial occurrence of the disease in 1972 and other studies have noticed familial clustering of the disease (12,20). Stigma and discrimination play a significant role in one's life within the community. What makes podoconiosis patients different from other stigmatized diseases is that the stigma and discrimination affects not only patients but also healthy individuals of patient families.

## **SECTION: 7 Conclusions**

Based on the study the following conclusions are made

1. podocniosis has familial tendency which contributes to directing stigma and discrimination to specific members of the community.
2. Wrong belief about the cause is highly prevalent among the society and health workers prohibiting prevention and timely medical care.
3. Stigma and discrimination seriously devastates the social. Psychological and economic well being of persons affected by podocniosis. The source of stigma and discrimination among the society is derived from the belief of the cause, treatment, and prevention. Out of these the belief of the cause to be hereditary, which is also observed scientifically, plays a significant role in stigma and discrimination.
4. Due to the stigma and discrimination associated with the disease patients try to deny the presence of the condition even when it is too obvious to deny it. This shows the extent of stigma and discrimination with in the society.
5. Health workers lack knowledge of the cause, which made their contribution to prevention insignificant.

## **SECTION: 8 Recommendations**

The following recommendation are forwarded based on the findings

1. There should be mobilization to raise awareness about the cause prevention and treatment of the disease among the society. This will help to decrease the stigma and isolation towards podoconiosis patients and to provide patients with proper care for patients.
2. Health professionals should be trained on the cause and prevention and of the disease so that they can launch effective prevention activities in the area.
3. Studies should be done in other parts of Ethiopia to see the prevalence and social impact of the disease.
4. Low cost protective shoes should be available in the market sufficiently for the use by the community.
5. MFTPA should extend its magnitude towards educating health professionals and unaffected family members.
6. Further study on the heritability can be done using laboratory methods using sib pair analysis since enough number of sib pairs are found with in the society.

## REFERENCE

1. Price E.W. Podoconiosis: non-filarial elephantiasis; Oxford University Press, 1990
2. Coreil Jeannine, Mayard Gladys, Louis- Charles Jacky and Addis David. Filariasis elephantiasis among Haitian women: social context and behavioral factors in treatment. *Tropical Medicine and International health* 1998; 3(6): 467
3. Gyapong Margaret, O. Gyapong John, Adjei Sam, Vlassoff Carol and Weiss Mitchell. Filariasis in northern Ghana:some cultural belifes and practices and their implication for disease control. *Soc. Sci. Med.* 1996; 43(2): 235-242
4. Price E.W. A possible genetic factor in non-filarial elephantiasis of the lower legs *Ethiop.Med.J.*1972; 10: pp.87-93.
5. Desta Kelemu, Ashine Meskele, Davey Gail. Prevalence of podoconiosis (endemic non filarial elephantiasis) in Wolaitta, south Ethiopia. *Trop. Doct.*2003; 333(4): 217-220
6. L.B. Cohen, idiopathic lymphoedema of Ethiopia and Kenya. *East Africa Medical Journal* 1960; 37 (2): 53-74
7. Price EW, Endemic elephantiasis: early sign and symptom and control; *Ethiop. Med. J.* 1983; 21: 243-253
8. Oomen, A. P. Studies on the legs in Ethiopia. *Trop.Geogr.Med.*236 (21) cited in Price E.W., A possible genetic factor in non-filarial elephantiasis of the lower legs, *Ethiop. Med. J.* 1972; 10: 87-93.
9. Price E.W. The association of endemic elephantiasis of the lower legs in east

- Africa with soil derived from volcanic rocks. *Tran. Roy. Soci. Trop. Med. Hyg.* 1976; 70(4): 289-95
10. Price EW. Endemic elephantiasis of the lower leg in Ethiopia an Epidemiological survey. *Ethiop. Med. J* 1974; 12: 77-91
  11. E.W. Price. The relationship between endemic elephantiasis of the lower legs and the local soils and climate. Wellamo district, South Ethiopia. *Trop. Geog. Med.* 1974; 26: 225-230
  12. Genene Mengistu, Humber, Dp. Mulugeta Ersumo and Tadesse Mamo. high prevalence of elephantiasis and cutaneous leishmaniasis in Ocholo, south Ethiopia. *Ethiop. Med. J* 1987; 25: 203- 07
  13. Leykun jemaneh, Derege Kebede. Clinico epidemiological study of filariasis in southwestern Ethiopia. *Ethiop. Med. J* 1995; 33: 143-53
  14. Price E.W. &J. Henderson W. The elemental content of lymphatic tissues in Ethiopia, with reference to endemic elephantiasis of the lower legs *Trans. Roy. Soci. Trop. Med. Hyg,* 1978; 72(2): 133-36
  15. C.J. Heather and E.W. Price. Non-filarial elephantiasis in Ethiopia analytical study of inorganic material in lymph nodes. *Tran. Roy. Soci. Trop. Med. Hyg.* 1972; 66(3): 450- 58
  16. D.P Burkitt and Maria Tunstall. Common geography as a clue to causation. *Trop. Geog. Med.* 1975; 27: 117- 124
  17. E.W. Price. Pre- elephantiasic stage of endemic nonfilarial elephantiasis of the lower legs: " podoconiosis". *Tropical Doctor* 1984; 14: 115-19

18. Yang Quanhen, J. Khoury Muin, Flanders W. Dona. Sample size requirement in case-only designs to detect gene-environment interaction Am .J. Epidemiology 1997; 146:713-20
19. Yang Quanhe &J. Khoury Muin. Evolving methods in genetic epidemiology III. Gene environment interaction in epidemiologic research; published with modification in epidemiologic reviews 1997; 19:33-43
20. Price E.W., A possible genetic factor in non-filarial elephantiasis of the lower legs, Ethiop. Med. J. 1972; 10:87-93.
21. Angelo A. Alzanzo, Nancy R. Reynolds. Stigma, HIV and AIDS: an exploration and elaboration of the stigma trajectory. Soc. Sci. Med 1995; 41 (3): 303-315
22. NE Groce; Disability in cross cultural perspective: rethinking disability. Lancet 1999; 354: 756-57
23. Khuzama shaar, Mark McCathy. Definition and determinants of handicap in people Epidemiological reviews1994; 16 (2): 228-42
24. Central statistical authority. Population & housing census of Ethiopia; results at country level. Statistical report.1994; volume 1:15-30
25. Southern Nation Nationality Peoples Region (SNNPR) health bureau. SNNPR health profile, Wolayita zone 2002: year 2 volume 2: 10-11
26. J. Khoury Muin & M. James Levy. Population and familial relative risks of disease associated with environmental factors in the presence of gene-environment interaction. Am. J. Epidemiology 1993; 137:1241-50
27. USAID. A conceptual framework and basis for action: HIV/AIDS stigma and

discrimination. June 2002

28. Price EW. Is elephantiasis a geochemical disease? *Ethiop. Med. J* 1976;

14:213-18

29. Price EW. Non- filarial elephantiasis of the lower leg \_confirmed as a

geochemical disease and renamed podoconiosis. *Ethiop. Med. J* 1988; 26:

151-53

## **Annex I**

### **Guide questions for the in depth interview**

#### **A. Belief about the cause of podoconiosis**

1. What is the cause of podoconiosis?
2. What is the treatment for podoconiosis?
3. What should one do to prevent podoconiosis?

#### **B. Stigma and discrimination**

##### **Marriage**

4. What sayings are there about podoconiosis patients?
5. Can a man with podoconiosis marry a normal girl/ woman?
6. Can a woman with podoconiosis a normal man?
7. How are marriage arrangements made in families with podoconiosis affected members?

##### **Leadership**

8. Can a person with podoconiosis be selected for local leadership?
9. Would a family with podoconiosis be a candidate for local leadership?

##### **School**

10. What remarks are given by students to podoconiosis affected students?
11. What remarks are given by teachers to podoconiosis affected students?

##### **Market and other social events**

12. Do podoconiosis affected people equally participate in the market places?
13. Do podoconiosis affected individuals equally participate in funerals, wedding ceremonies etc...?

**Annex II**

**PEIGREE QUESTIONNAIRE TO COLLECT INFORMATION ON THE PATTERN OF PODOCONIOSIS ACROSS GENERATION**

**II) Information on the pattern of disease across generation**

**3<sup>RD</sup> GENERATION**

Birth order	Ethnicity	Age	Sex	Relationship With the proband	Disease status		If yes age at which the disease started	Uses shoes		If yes describe the type of shoe	Alive		If no age at death	R e m a r k
					Yes	No		Yes	no		Yes	no		
1														
2														
3														
4														
5														
6														
7														
8														
9														
10														
11														

- 1= sister-have both the same father and mother
- 2=brother- have both the same father and mother
- 3=half sister- have the same mother but different father.
- 4= half sister- have the same father but different mother
- 5= half brother- have the same mother but different father
- 6= half brother- have the same father but different mother
- 7= step sister-have no blood line with the proband
- 8= step brother have no blood line with the proband

Which of them are probands? No. \_\_\_\_\_ & \_\_\_\_\_

Ethnicity -1 wollaita 2. Amhara 3. Gamo 4. Sidama 5. Gurage 6. Oromo 7. Tigre 8. Others (describe ) \_\_\_\_\_

**2<sup>ND</sup> GENERATION**

**A) ON THE SIDE OF THE PROBAND'S MOTHER**

Birth order	Ethnicity	Age	Sex	Relationship With the proband	Disease status		If yes age at which the disease started	Uses shoes		If yes describe the type of shoe	Alive		If no age at death	Remarks
					Yes	No		Yes	no		Yes	no		
1														
2														
3														
4														
5														
6														
7														
8														
9														
10														
11														

9= sister-have both the same father and mother

10=brother- have both the same father and mother

11=half sister- have the same mother but different father.

12= half sister- have the same father but different mother

13= half brother- have the same mother but different father

15= half brother- have the same father but different mother

16= step sister-have no blood line with the proband

17= step brother have no blood line with the proband

Which one of them is the probands mother? No. \_\_\_\_\_

Ethnicity -1 wollaita 2. Amhara 3. Gamo 4. Sidama 5. Gurage 6. Oromo 7. Tigre 8.

Others (describe ) \_\_\_\_\_

**B) ON THE SIDE OF THE PROBAND'S FATHER**

Birth order	Ethnicity	Age	Sex	Relationship With the proband	Disease status		If yes age at which the disease started	Uses shoes		If yes describe the type of shoe	Alive		If no age at death	R e m a r k
					Yes	No		Yes	no		Yes	no		
1														
2														
3														
4														
5														
6														
7														
8														
9														
10														
11														

- 18= sister-have both the same father and mother
- 19=brother- have both the same father and mother
- 20=half sister- have the same mother but different father.
- 21= half sister- have the same father but different mother
- 22= half brother- have the same mother but different father
- 23= half brother- have the same father but different mother
- 24= step sister-have no blood line with the proband
- 25= step brother have no blood line with the proband

Which one is the probands father? No. \_\_\_\_\_

Ethnicity - 1 wollaita 2. Amhara 3. Gamo 4. Sidama 5. Gurage 6. Oromo 7. Tigre 8. Others (describe)\_\_\_\_\_

## 1<sup>ST</sup> GENERATION

### 1. Grand parents of the proband on the mother's side

#### 1.1 The grandmother

- A) Ethnicity \_\_\_\_\_
- B) Sex **F** \_\_\_\_\_
- C) Age \_\_\_\_\_
- D) What is the relationship of the grand mother with the probands father?
  - 1) She is a blood mother
  - 2) She is a stepmother
  - 3) Others \_\_\_\_\_
- E) Does she have podoconiosis?
  - 1) Yes
  - 2) No
  - 3) I don't know
- F) If yes at what age did she got the disease? \_\_\_\_\_
- G) Does she use shoes?
  - 1) Yes
  - 2) No
  - 3) I don't know
- H) If yes what was the type of shoes? \_\_\_\_\_
- I) Where is she now?
  - 1) Alive
  - 2) Dead
- J) If she is dead what was her age at death? \_\_\_\_\_

#### 1.2 The grand father

- A) Ethnicity \_\_\_\_\_
- B) Sex **M** \_\_\_\_\_
- C) Age \_\_\_\_\_
- D) What is the relationship of the grand father with the probands father?
  - 1) He is a blood father
  - 2) He is a stepfather
  - 3) Others \_\_\_\_\_
- E) Does he have podoconiosis?
  - 1) Yes
  - 2) No
  - 3) I don't know
- F) If yes at what age did he got the disease? \_\_\_\_\_
- G) Does he use shoes?
  - 1) Yes
  - 2) No
  - 3) I don't know
- H) If yes what was the type of shoes? \_\_\_\_\_

- I) Where is he now?
- 1) Alive
- 2) Dead
- J) If he is dead what was his age at death? \_\_\_\_\_

**2. Grand parents of the proband on the father's side**

**2.1 The grand mother**

- A) Ethnicity\_\_\_\_\_
- B) Sex\_\_**F**\_\_
- C) Age\_\_\_\_\_
- D) What is the relationship of the grand mother with the probands father?
- 1) She is a blood mother
- 2) She is a stepmother
- 3) Others\_\_\_\_\_
- E) Does she have podoconiosis?
- 1) Yes
- 2) No
- 3) I don't know
- F) If yes at what age did she got the disease?\_\_\_\_\_
- G) Does she use shoes?
- 4) Yes
- 5) No
- 6) I don't know
- H) If yes what was the type of shoes? \_\_\_\_\_
- I) Where is she now?
- 1) Alive
- 2) Dead
- J) If she is dead what was her age at death?\_\_\_\_\_

**2.2The grandfather**

- A) Ethnicity\_\_\_\_\_
- B) Sex\_\_**F**\_\_
- C) Age\_\_\_\_\_
- D) What is the relationship of the grand father with the probands father?
- 1) He is a blood father
- 2) He is a stepfather
- 3) Others\_\_\_\_\_
- E) Does he have podoconiosis?
- 1) Yes
- 2) No
- 3) I don't know
- F) If yes at what age did he got the disease? \_\_\_\_\_
- G) Does he use shoes?
- 1) Yes

2) No

3) I don't know

H) If yes what was the type of shoes? \_\_\_\_\_

I) Where is she now?

1) Alive

2) Dead

J) If she is dead what was her age at death? \_\_\_\_\_

**4<sup>th</sup> GENERATION**

(Only if the proband have children of his/her own)

Birth order	Ethnicity	Age	Sex	Relationship With the proband	Disease status		If yes age at which the disease started	Uses shoes		If yes describe the type of shoe	Alive		If no age at death	R e m a r k
					Yes	No		Yes	no		Yes	no		
1														
2														
3														
4														
5														
6														
7														
8														
9														
10														
11														
12														
13														
14														
15														
16														

- 16= daughter-the proband is a blood father or mother
- 27=son- the proband is a blood father or mother
- 28= step daughter- the proband is not a blood father or mother
- 29= step son –the proband is not a blood father or mother

