



ADDIS ABABA UNIVERSITY
SCHOOL OF MECHANICAL & INDUSTRIAL ENGINEERING
(RAILWAY ENGINEERING STREAM)

ERGONOMICS ASSESSMENT AND PREDICTION MODEL OF PASSENGERS COMFORT IN A.A-LRT



A Master's thesis proposal submitted to the school of graduated studies of Addis Ababa universities in partial fulfillment of the requirement of the degree of Master of Science in mechanical engineering under (railway stream)

By: Surafel Shiferaw

Advisors: Dr. Gulelat Gatew

June 2015

Approved by: Board of Examiners

Chairman of Department Signature Date

Graduate Committee (DGC)

Dr. Gulelat Gatew.  June 06/2015

Advisor Signature Date
 June 06/2015

Internal examiner
Dr. Birahnu Beshah Signature Date

External examiner
Dr.-Ir. Eshetie Berhan  June 06/2015

Associate Dean,
Research and graduate program Signature Date
 08/06/15
Birhanu Beshah(PhD)
Head, Railway
Engineering Centre

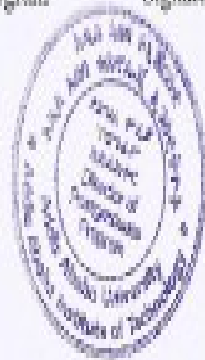

DECLARATION

I hereby declare that the work which is being presented in this theses entitled "Ergonomics assessment of passengers comfort along AA-LRT and development of prediction model" is original work of mine, has not been presented for a degree of any other university and all the resource of materials used for this theses have been duly acknowledged.

Asst

Sarafel Shiferaw

June 06/2015

Date

This to certify that the above declaration made by the candidate is correct to the best of my knowledge.

Dr. Gulelat Gatew

Dr. Gulelat Gatew.

(Advisor)

June 06/2015

Date

ACKNOWLEDGEMENTS

Firstly, I would like to express my deepest gratitude to my advisor Dr. Gulelat Gatew, for his constant motivation, guidance, support, supervision and constructive suggestion throughout this thesis work. I want also to thank Dr. Birhanu Besha for suggesting significant data to keep the research on track. My sincere gratitude goes to Dr.Ir.-Eshetie Berhan for his valuable advice on research methodology teaching guide.

Finally, I gratefully acknowledge the staff of Addis Ababa light rail transit project manager, (Ethiopia Railway Corporation) for providing me the necessary information for the input of this thesis work.

Surafel Shiferaw

June, 2015

ABSTRACT

Most problems in Ethiopia are the improper allocation of the job to the right because the areas do not properly allocate workers to the correct knowledge of the works since ergonomics principles and benefits are not yet known well in our country. The research study was intended to investigate whether the new rail vehicle interior design is appropriate with the sense of passenger comfort and goodness of passenger fit in seating dimensions with passenger's anthropometric variables since the population of Addis Ababa human posture size are not being considered using ergonomics design and principle. The aim of this field study was to explore passenger comfort through the development of prediction model using statistical methods using passenger's anthropometric variables.

The data's were collected and analyzed for both passenger seat and standing capacities where a descriptive statistics such as means, standard deviations, fifth, seventy fifth and ninety fifth percentiles were being analyzed for the passenger seat dimensions. A multiple regression prediction model was also conducted to estimate the anthropometric parameters on passenger's standing.

As per the analysis of goodness of fit between the percentiles of passengers anthropometric and the train vehicles seats, a passenger mismatch has been observed in only male's shoulder breadth and vehicles backrest width, and passengers mismatch had been also investigated using T-test using descriptive analysis in three corresponding parameters. These are between (hip breadth and seat width), (shoulder breadth and backrest width), and (knee height and seat height).

Multiple regression models demonstrated, Passenger body mass index is the most statistically significant factor in predicting the passenger comfort using passenger anthropometric variables inside the rail vehicles. Therefore Passenger body mass index has been found as a better predicting model instead of passenger capacity models in better predicting passenger comfort and space allocations along Addis Ababa light rail transits.

Key words: Engineering Anthropometry, biomechanics, ergonomic design, Addis Ababa Light Rail Transit (AA-LRT), Body surface area, Body mass index, Seat configuration.

ABBREVIATIONS

AWO	Total car weight with no passengers in a revenue service ready.
AW2	AW0 + full seated passenger load
AW3	AW1 + Standing passenger load of 4 people per m ²
AW4	AW1 + Standing passenger load of 6 people per m ²
AA-LRT	Addis Ababa Light Rail Transit
BMI	Body Mass Index
BPL	Buttocks to Popliteal Length
BSA	Body Surface area
Cir	Circumference
ERC	Ethiopian Railway Corporation
KH	Knee height
LRV	Light Rail Vehicles
HB	Hip breadth
SSH	Sitting to Shoulder Height
SB	Shoulder breadth
SH	Sitting height
SPSS	Social Package for Social science

TABLE OF CONTENTS

ACKNOWLEDGEMENTS	i
ABSTRACT	v
ABBREVIATIONS	vi
LIST OF FIGURES	vi
LIST OF TABLES	vii
CHAPTER ONE	1
INTRODUCTION	1
1.1 Background of the study	1
1.2 Physical Ergonomic Considerations in Product Design.....	3
1.2.1 Passenger seating Comfort during transportation	4
1.3 Statement of the Problem	5
1.4 Research Question.....	6
1.5 Objectives of the study	7
1.5.1 General Objective	7
1.5.2 Specific objectives	7
1.6 Scope and Limitations of the Study	7
1.6.1 The scope of the research	7
1.6.2 Limitation of the research.....	8
1.7 Significance of the study	8
1.8 Outline of the study	8
CHAPTER 2	10
LITERATURE REVIEW	10
2.1 Review of Literature.....	10
2.2 Human Factor Consideration in vehicle Seat Design.....	11
2.3 Anthropometry	12
2.3.1 Anthropometric variables of passengers.....	12
2.4 Ergonomic design for humans.....	13
2.5 Ergonomics in the automotive industry	14

2.6 Relationship between comfort and discomfort and their factors.....	15
2.7 Standards, Guidelines and recommendations.....	15
CHAPTER THREE	16
DATA COLLECTION AND ANALYSIS	16
3.1 Data gathering.....	16
3.1.1 Primary data.....	16
3.1.2 Secondary data.....	18
3.2 Methodology of the Study.....	20
3.4 T-test analysis.....	40
3.5 Chi-Squared Test of Independence.....	42
3.6 Chi Squared tests using SPSS.....	46
3.7 Evaluation of Passenger rail vehicle seat dimensions.....	47
CHAPTER FOUR	69
DEVELOPMENT OF STATISTICAL PREDICTION MODEL	54
4.1 Introduction.....	54
4.2 Assumption for sample size.....	55
4.3 SPSS Output Model Summary.....	59
4.4 Mathematical Prediction Model of passenger standing.....	63
4.5 Result and Discussion.....	66
4.6 Major Findings.....	68
CHAPTER FIVE	69
CONCLUSION AND RECOMMENDATION AND FUTURE RESEARCH DIRECTION ..	69
5.1 Conclusions.....	69
5.2 Recommendations.....	70
5.3 Future Research Direction.....	70
BIBLIOGRAPHY	71
APPENDIX: SPSS DATA OUTPUT	73

LIST OF FIGURES

Figure 1.1 AA-LRT vehicle seat gap and passenger discomfort	3
Figure 1.2 Observational problems in the new light rail vehicle and Anbesa bus in Addis Ababa ...	6
Figure 2.1 Human anthropometric dimensions.....	14
Figure 3.1 Interior layout measurement of AA-LRT Rail Vehicle seat..	16
Figure 3.2 Observation measurement of twin passenger and five passenger rail vehicle seat.	18
Figure 3.3 The Anthropometric measurement of passenger seat measurement.....	20
Figure 3.4 Chi-square critical value.....	44
Figure 3.5 SPSS output of Chi Squared Tests	46
Figure 3.6 Evaluation of Passenger rail vehicle seat dimensions	48
Figure 3.7 A Scatter plot of passenger's body surface area and weight.	58

LIST OF TABLES

Table 1.1 Causes of seating comfort.....	4
Table 3.1 Technical Information on Light Rail Vehicles (LRV)	17
Table 3.2 The specification data on rail vehicle seating capacity.	17
Table 3.3 The number of data observed in recent research paper	20
Table 3.4 Addis Ababa Adult anthropometric Data-Men shoulder breadth	22
Table 3.5 Engineering Anthropometry and Standard measurement of statistics.....	23
Table 3.6 Addis Ababa Adult anthropometric Data-Men shoulder to hip.....	24
Table 3.7 Addis Ababa Adult anthropometric data.	25
Table 3.8 Addis Ababa Adult anthropometric data table-men for waist circumference.	26
Table 3.9 Addis Ababa Adult anthropometric Data table-men shoulder- breadth length.	27
Table 3.10 Addis Ababa Adult anthropometric Data table-men Waist to knee point length.	28
Table 3.11 Addis Ababa Adult anthropometric Data table-men knee point to ankle length.....	29
Table 3.12 Addis Ababa Adult anthropometric data table-men for Hip circumference.....	30
Table 3.13 Addis Ababa Adult anthropometric data table-men for Thigh circumference.	31
Table 3.14 Addis Ababa Adult anthropometric Data table-Women shoulder to hip length.....	32
Table 3.15 Addis Ababa Adult anthropometric Data table-women shoulder.....	33
Table 3.16 Addis Ababa Adult anthropometric Data table-women sleeve length.	34
Table 3.17 Addis Ababa Adult anthropometric Data table-women waist circumference.	35
Table 3.18 Addis Ababa Adult anthropometric Data table-women Hip circumference.....	36
Table 3.19 Addis Ababa Adult anthropometric Data table-women Thigh circumference.	37
Table 3.20 Addis Ababa Adult anthropometric Data table-women, buttock to knee point.....	38
Table 3.21 Addis Ababa Adult anthropometric Data table-women knee to ankle point.	39
Table 3.22 T –test analysis of seat dimensions and rail passengers’ anthropometric dimensions. ...	41
Table 3.23 Table of Critical Values for Critical Significance Levels (α : alphas).	41
Table 3.24 Chi-square statistics(X^2) for related percentages comparison.	42
Table 3.25 Chi-square test analysis of passengers’ male anthropometric and seat dimensions.	45
Table 3.26 Chi-square test analysis of passengers ‘female anthropometric and seat dimensions. ...	47
Table 3.27 Sample of observations in existing seat height.	48
Table 3.28 Sample of four observations in existing seat width.	49

Table 3.29 Sample of four observations in existing seat depth.	50
Table 3.30 Sample of four observations for backrest height.	51
Table 3.31 Sample of four observations for backrest width.	51
Table 3.32 Dimensions of existing passenger seat of new rail vehicle.	52
Table 3.33 Summary of the Anthropometric Dimensions for male.....	53
Table 3.34 Summary of the Anthropometric Dimensions for female.	53
Table 4.1 Addis Ababa passengers body surface area interpretation.	56
Table 4.2 Descriptive statistics	57
Table 4.3 Model summary	59
Table 4.4 LRT specification on weights of vehicles and passengers	60
Table 4.5 Seating capacity of vehicles used by Addis Ababa LRT specification.	60
Table 4.6 Number of passengers and weight used by Addis Ababa LRT specification.....	61
Table 4.7 Equations on the estimation of the anthropometric parameters on passenger body.....	65

CHAPTER ONE

INTRODUCTION

1.1 Background of the study

Addis Ababa, the capital of Ethiopia has been facing with huge challenges emanating from years of poor coordination between its existing urban systems. Transport is one of these components of the urban system, which is responsible for bridging the gap between areas of production and consumption, as well as creating a medium for spatial interaction, continues to be in the thick of these challenges. The lack of properly planned urban transport in Addis-Ababa is manifested through the low degree of efficiency of urban mobility that is now observed in almost all of the city's center, sub-centers and other major traffic corridors [4].

Long-distance coach services, e.g. express buses, are transporting passengers from city to city and serve as main commuter for towns [1]. The coach passenger seat is one of the important features to ensure the comfort of the passenger for long distance travel. In the long journey, the bus passengers may seat more than 10 hours and above. The bus passengers can perform activities like reading, listening music or sleeping on the selected bus seat.

A high level of satisfaction and comfort with public transportation services reflects public confidence and the willingness of people to use the service. Due to the lack of consistent concerted efforts from the various stakeholders, Passenger discomfort and Congestion has been a common challenge in all the different parts due to lack awareness on ergonomics principle and other factors in the city of Addis Ababa.

Ergonomics design considerations are very important for passenger seats for all transport vehicles. Long-distance coach services, e.g. express buses, are transporting passengers from city to city and serve as main commuter for towns without any railway service. Some of discomfort areas are observed at the new light rail transit passenger that indicates that the Addis Ababa adult human posture dimensions are not being considered with the existed rail seat dimensions experience during the travelling in the bus.

Ergonomics or human factor is not only a new science for Ethiopian organizations but also for the world industries. In Ethiopia most of the industries and service sectors do not have awareness and what ergonomics engineering is by itself is a magic concept.

According to the research presentation by International Labor Organization (ILO) conference took place in the Addis Ababa exhibition center on April 28, 2009, [8] the Ethiopian industries and service sectors do not aware of ergonomics principle and management system from the aspect of ergonomics. Most problems in Ethiopia are the improper allocation of the job to the right because the areas do not properly allocate workers to the correct knowledge of the works since ergonomics principles and benefits are not yet known well in our country.

Ergonomics, as applied to product design is a technology for creating products that is agreeable to the physical characteristics of product users and has the objective of ensuring that these end-users interact with products safely so that their work output is maximized. In ergonomics, design begins with an understanding of the user's role in the overall product/system performance and products/systems and anthropometric considerations. There are three basic human factors that should be accommodated in design: one is that people are different in shape and size, two that people have limitations physically and mentally, and three that people have predictable reactions to events based on their life experiences. Ergonomics, applied to product design is a technology for creating products that is agreeable to the physical characteristics of product users and has the objective of ensuring that these end-users interact with products safely so that their work output is maximized. In ergonomics, design begins with an understanding of the user's role in the overall product/system performance and products/systems exist to serve their users, whether they are consumers or system operators.



Figure1.1 AA-LRT vehicle seat gap and passenger discomfort

1.2 Physical Ergonomic Considerations in Product Design

Physical ergonomics is guided a set of interrelated principles, which though appear simple and self-evident but are routinely violated in the design of products. Taken as a whole, these tenets represent what to look for in the design of products and finding ways to promote safety and comfort during user-product interaction. The principles of physical ergonomics are:

1. Limit exposure to contact pressure.
2. Reduce tissue distortion
3. Reduce moisture in person-product interface.
4. Moderate heat build-up in person-product interface.
5. Limit exposure to shear forces.
6. Reduce application of excessive force.

7. Moderate body motions.
8. Promote postures of least stress.
9. Minimize static load

1.2.1 Passenger seating Comfort during transportation

Seating comfort is a major concern for passengers and other members of the work force, even passengers who are exposed to extended periods of sitting and its associated side effects [9]. Although there are several other categories of people such as patients who are concerned with seating comfort, drivers represent a large percentage. Some of the main factors that affect seating comfort are seat-interface pressure distribution, whole-body vibration and pressure change rate. The term “seat comfort” is typically used to define the short-term effect of a seat on a human body. Seating discomfort has been examined from a number of different perspectives. The problem with evaluating comfort in regards to pressure or any other factor is that, comfort is very subjective and not easily quantified. Seating discomfort varies from subject to subject and depends on the task at hand. Comfort however, is a vague concept and subjective in nature. It is generally defined as lack of discomfort.

Table 1.1 Causes of seating comfort

Vehicle ride	Biomechanical	Engineering	Seat/environment
Human experience mode	Physical causes	Engineering causes	Sources
Pain	Circular occlusion	Pressure	Cushion stiffness
Pain	Ischemia	Pressure	Cushion stiffness
Pain	Nerve occlusion	Pressure	Seat contour
Discomfort	-	Vibration	Contour
Perspiration	Heat	Material	Vinyl upholstery
		Breathability	
Perspiration	Visual/auditory/tactical	Design/vibration	Vehicle cost

To develop an integrated design of bus passenger seat, the total design technique should be used including the process of the seating design that requires appropriate material selection, identify standard requirements, conceptual design to weight reduction for safe comfort in train bus transport.

1.3 Statement of the Problem

In Ethiopia physical anthropometric measurements (human factors) are not widely considered in the design and manufacturing of products. This is due to lack of proper anthropometric percentiles and average size, this makes difficult in designing products and other working area of the population without consideration of shape and size. Due to this reason, the manufacturing of AA-LRT passenger seat has been manufactured mainly using the common sense and art of the foreign manufacturing technician and standards. The rail vehicle seats are designed using other population who has different anthropometric measurements.

In Addis Ababa public transportation, passenger congestion had been a significant problems even in recent transportation routes throughout Addis Ababa. This is due to improper design of passenger space and allocation, insufficient aisle space and poor seat design. As it is shown below in figure 1.2 Passenger Seat discomfort is still observed in some transport along Addis Ababa transport system since long hour travel will create physiological stress and psychological stress during transportation of passengers. It may due to vibration, noise, as well as seat comfort. The research study was intended to investigate whether the rail vehicle design is appropriate with the sense of passenger comfort and goodness of fit with passenger's anthropometric variables and other factors, due to this reason the following problems are considered for research analysis.

- The seats and the passenger's places are not well designed with the sense of comfort.
- The Addis Ababa human posture size is not being considered into account in the rail vehicle design.
- An investigation on a significance of difference between an assumed passenger average weight and a scenario with randomly generated anthropometric variables of Addis Ababa population, including the rest of unaccounted weight.



Figure1.2 Observational problems in the new light rail vehicle and Anbesa bus in Addis Ababa

1.4 Research Question

- Why Ethiopian Railway Corporation (ERC) simply assumed six passengers with average of 60 kg of each passengers standing in one meter square.
- How the rail vehicle passenger seat dimensions are matching with Addis Ababa population anthropometric size?
- Which anthropometric variables better predict passenger allocations inside rail vehicles?
- Which type of independent variables better predicts passenger body mass index(dependent variable) in the new rail vehicles with the sense of comfort?

1.5 Objectives of the study

1.5.1 General Objective

The general aim of this study is to investigate and propose a better solution in the title of, “Ergonomics assessment of passenger comfort along AA-LRT and development of prediction model” through statistical analysis by testing anthropometric and rail dimensions to predict a better model for passenger discomfort.

1.5.2 Specific objectives

1. To investigate the passenger weight allocation with other scenario using unaccounted weights of passenger items.
2. To investigate the passenger mismatch areas in passenger seating using statistical method and test. Thereby, creating an appropriate passenger seat interval using statistical mean, standard deviations and anthropometric percentages.
3. To propose a better passenger standing statistical model inside the rail vehicles with the sense of comfort.
4. To compare and contrast the statistical prediction models in passenger’s allocations of anthropometric dimensions and other correlational variables.

1.6 Scope and Limitations of the Study

1.6.1 The scope of the research

The study on this research paper, “Ergonomics assessment on passenger comfort in rolling stock seat” is vast since much anthropometric data is therefore it requires a tremendous time and wide observation data. Therefore, the research study is delimited to only consider five parameters for ergonomics required. Due to lack of ergonomic parameters inside the rail vehicle seat configuration, anthropometric dimensions of armrest and headrest of passenger evaluation are not being considered.

1.6.2 Limitation of the research

The accomplishment of Ababa Light rail transit project installation is not finished by now hence in order to investigate the passenger seating comfort of new rolling stock performance is challenging due to lack of sufficient data. Therefore, this research paper investigates the viability and credibility of the problem by comparing the previous transit modes in order to exchange the previous cultural trend. Another expected challenge of this study was the non-response rate through the target respondents' including the concerned body of Ethiopian railway corporation staff managers, due to lack of the required information. In general, this research is limited due to shortage of time since most research enquires sufficient information and long period of time.

1.7 Significance of the study

The beneficiaries are;

- Addis Ababa Light Rail Transit, as one of the best competitive transport provider throughout the city.
- The organization (ERC) in implementing this topic idea.
- For Addis Ababa Light Rail Transit Passengers in feeling comfort and being safe.

The benefit could be:

- Increasing the passenger satisfaction by providing better comfort and service.
- Reducing fatigues, motivating the concerned people and putting proper seat position that solves the problem of improper allocation of the passenger's seat.
- To investigate the physical mismatches between dimensions of seating and the corresponding users.
- The one who needs to continue his research on this topic and may add details having this hint.

1.8 Outline of the study

The research paper is structured in six chapters. The first chapter discusses about describing the background of the study, the statement of the problem, objectives, significance of the study finally the scope and limitation of the research. The second chapter covers literature review dealing with an overview of passenger sitting comfort, the effect of crowding in public transport in Addis Ababa public bus transportation and the problem will also be investigated through some countries. The methodological framework of the study is described in third chapter where it deals with further detail about methods of data used for carrying out the study. The fourth chapter deals with data collection and ergonomics analysis.

Finally the last chapter deals with statistical model equation, conclusion and recommendation and future direction of the research paper.

CHAPTER 2

LITERATURE REVIEW

2.1 Review of Literature

Ergonomics is an interdisciplinary field of study that seeks to design systems in which people play a significant role such that the interrelationship between the human and the system is optimized. A system could be a simple hand tool, a complex product such as an automobile, or an organization's workplace including the associated tasks that are performed.

The fundamental aim of ergonomics is that all human-made tools, devices, equipment, machines, and environments should advance, directly or indirectly, the safety, well-being, and performance of human beings. Bridger, R.S. (1995) [6], defined ergonomics as a systematic and rational means of fitting the work to the person and has the primary goal of improving worker performance and safety through the study and development of general principles that govern the interaction of people and their working environment. Ergonomics has a physical aspect and a cognitive aspect. Physical ergonomics is concerned with fitting the physical aspect of the human, that is, body size, body shape and strength capabilities, to design while cognitive ergonomics focuses on providing a fit between a person's mental capabilities and a design at hand. In the United States, Physical ergonomics is simply referred to as ergonomics while cognitive ergonomics is called human factors. This dissertation is concerned with physical ergonomics, and the latter will simply be called ergonomics and is defined as the body of knowledge concerned with the study of human capabilities and limitations to be used in the design of systems, which may be products, tasks, and environments, to ensure that biomechanical stresses to the user are minimized and that safety and human performance are optimized.

There are three basic human factors that should be accommodated in design [10]: one is that people are different in shape and size, the other is people have limitations physically and mentally and, lastly, people have predictable reactions to events based on their life experiences. Ergonomics, applied to product design is a technology for creating products that is agreeable to the physical characteristics of product users and has the objective of ensuring that these end-users interact with products safely so that their work output is maximized. In ergonomics, design begins with an

understanding of the user's role in the overall product/system performance and products/systems exist to serve their users, whether they are consumers, system operators.

2.2 Human Factor Consideration in vehicle Seat Design

During the seated posture, in the human anatomy the buttocks, thighs, lower legs and knees act as mechanical levers that provide stability to the body. According to research, prolonged exposure to an inadequately supported posture results in excessive static loads on the above mentioned body parts culminating in a sensation of discomfort. Experiencing localized high pressure at the human-seat interference causes soft tissue deformation that result in restricted blood and nutrient flow to the lower extremities leading to human discomfort.

Ergonomics is the applied discipline of science connecting human life to its well-being during handling of consumer products. The car seat being situated in a restricted workbench experiences dynamic forces like centrifugal forces during motion, hence causing discomfort for the driver. This has led to the designing of seats using the basic ergonomic principles. The most significant role that ergonomics plays in the automobile design process is providing data on the physical attributes of driver and his/her favored postures while driving. The most important region that requires support in a human body is the backbone [10]. When designing products, it is important to adjust them after human's physical and psychological limitations to receive usability, avoid stress or injuries and achieve comfort which gives user value. As the anthropometric data is necessary for proper ergonomic design of passenger seats, anthropometric data for Ethiopian users of passenger seats is necessary and seems not reported, since the population is scant.

The correct design of passenger seats with emphasis on comfort as regard, the Ethiopian people arises due to the fact that the required anthropometric measurements are not available due to this reason; the Addis Ababa rail transit rail vehicle has been exported without the consideration of the concerned population of anthropometric human dimension and size.

Metin Tunay and Kennan Melemez [9], noted that physical dimensions of furniture, equipment, clothing and workspaces are specified using anthropometric data to achieve proper ergonomics design.

Similarly, Xiao et.al.9 (2005) [4] noted that anthropometric data is needed for ergonomically correct design of safe and efficient workplaces, equipment and tools.

Martin Freer (May 2011), the passenger seat width would not accommodate adjacent passengers without body contact [7]. This restricts the opportunity for passengers to change posture, not only because of the limited space but also because of the disturbance it may cause the adjacent passengers.

2.3 Anthropometry

Anthropometry is measuring of humans. In modern design, anthropometrics have an important role where it is useful for design, product development and work environments. Anthropometry is divided into different percentiles showing the variety of people with a certain measurement. 5th percentile shows that 5% have a measurement up to the given length. 95th percentile shows that 95% have a measurement up to the given length. 50th percentile is the medium measurement

Anthropometry is the science that measures the range of body sizes in a population. When designing products it is important to remember that people come in many sizes and shapes. Anthropometric data varies considerably between regional populations. For example, Scandinavian populations tend to be taller, while Asian and Italian populations tend to be shorter. Anthropometric dimensions for each population are ranked by size and described as percentiles. Anthropometric data varies considerably between regional populations.

2.3.1 Anthropometric variables of passengers

- Stature: Top of the head, standing in erect stretched posture.
- Shoulder breadth: Maximum horizontal distance across the shoulders, Breadth ensured to the protrusion of the deltoid muscles.
- Sitting height: Top of the head sitting in a normal relaxed posture.
- Sitting eye height: height of inner corner of the eye sitting in normal relaxed posture.
- Sitting mid shoulder height: Height of upper most point on the middle level of the shoulder.
- Popliteal height: Height of the underside of the thigh immediately behind the knee.
- Knee height: height of uppermost point on the knee.
- Hip breadth: Maximum horizontal distance across the hips.
- Elbow rest height: Distance between seat and lower most part of the elbow.

-
- Buttock popliteal length: Horizontal distance from the most posterior point on the uncompressed buttocks to the back of the lower leg at the knee.
 - Buttock knee length: Horizontal distance from the most posterior point on the uncompressed buttocks to most anterior.

2.4 Ergonomic design for humans

When designing products, it is important to adjust them after human's physical and psychological limitations to receive usability, avoid stress or injuries and achieve comfort which gives user value.

Ergonomics is the applied discipline of science connecting human life to its well-being during handling of consumer products. The car seat being situated in a restricted workbench experiences dynamic forces like centrifugal forces during motion, hence causing discomfort for the driver this has led to the designing of seats using the basic ergonomic principles [15].

Anthropometric data are used in ergonomics to specify the physical dimensions of work spaces, equipment, furniture, and clothing (Bridger, 1995; Kayis and Ozok, 1991; Jeong and Park, 1990). Appropriate use of anthropometry in design may improve the well-being, health, comfort, and safety of a product's users (Pheasant, 1998; Barroso et al., 2005). The use of poorly designed furniture, especially school desks and tables, which fails to account for the anthropometric characteristics of its users.

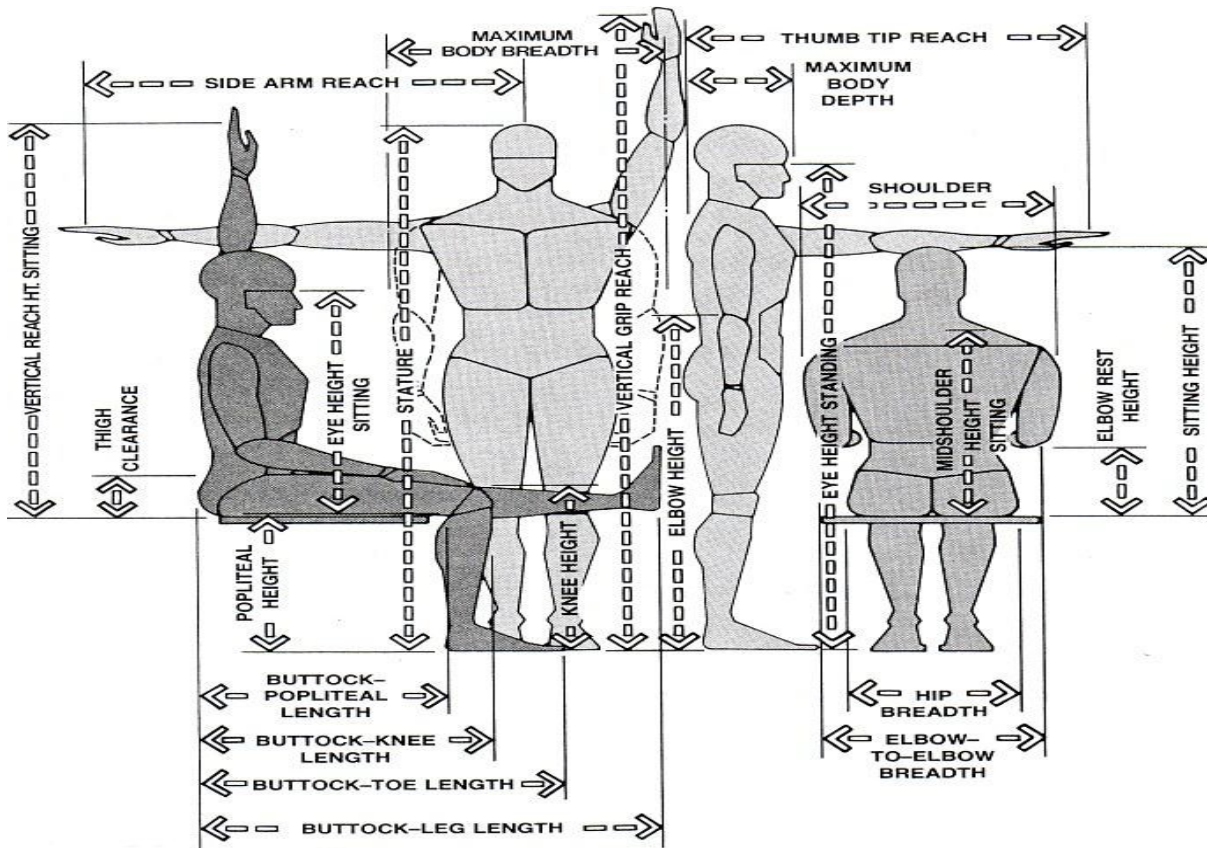

Figure 2.1 Human anthropometric dimensions

2.5 Ergonomics in the automotive industry

Tools and techniques used by ergonomists in the automotive industry are based on statistical data, Test drive, and Simulation and computer software[11]. Statistical data analysis and test drive are the primitive but not considered that much in now a days. In case of simulation and computer software they are using the same data sources and CAD tools and some simulative hardware. Simulative hardware runs user trials to evaluate their products; in some cases using only company staff as subjects, in other cases with members of the general public. They have good correspondence with universities and the organization is involved in research projects. Normally if there are no ergonomists then the data sources considered as out of date and user evaluations are rarely conducted. Overall Ergonomics evaluation depends on the quality of product and the price therefore only few model cars come with proper ergonomic design of car seat.

2.6 Relationship between comfort and discomfort and their factors

Quite different viewpoints are also found in the literature regarding The Society of Automotive Engineers (SAE) [13] has been particularly active in the generation of such Standards and many of these form part of the legislation which covers automotive design. In case of human body parts with their relevant posture SAE recommendations to Ergonomist are given below:

- SAE J826 H-point (ISO 6549).
- SAE J1100 Seating reference point.
- SAE J1100 H-point travel path.
- SAE J1517 Driver selected seat position.

2.7 Standards, Guidelines and recommendations

Many areas of ergonomics those are pertinent to automotive design. In case of occupant accommodation there is wide range of standards, guidelines and recommendations available those are extremely useful in the early stages of concept design because they are readily available. Some of the major giant company use their own or modified standard. Some of the standards and their associated procedures have already been developed or in developing process in the field of ergonomics.

EN 50126-1 (1999) describes the specification and demonstration of RAMS of railway applications. It contains the following definitions of verification and validation:

- **Verification:** Confirmation by examination and provision of objective evidence that the specified requirements have been fulfilled.
- **Validation:** Confirmation by examination and provision of objective evidence that the particular requirements for a specific intended use have been fulfilled.

The objective of verification is to demonstrate that, for the specific inputs, the deliverables of each phase meet in all respects the requirements of that phase. The objective of validation is to demonstrate that the system under consideration, at any step of its development and after its installation, meets its requirements in all respects.

CHAPTER THREE

DATA COLLECTION AND ANALYSIS

3.1 Data gathering

The basic method employed for data gathering is primary and secondary data. In this research study, both methods have been used in defending the anthropometry data of Addis Ababa adult people and compared with related previous research papers data's. Most of anthropometric data's are being taken from ambassador garment industry and some form different concerned tailors around Addis Ababa.

3.1.1 Primary data's

I. Measurement of Rail Vehicle Seat Dimensions

- Measurement for seat dimensions evaluation is important tool in the development of Rail bus seat to fulfill the criteria of ride comfort. The dimensions of existing manufactured passenger seats rail bus was analyzed by taking measurements on seat height, seat width, seat depth, back rest height and back rest width using meter..

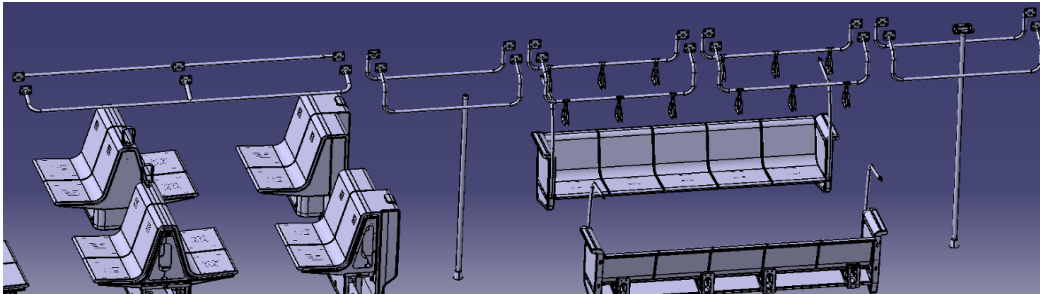

Figure 3.1 Interior layout measurement of AA-LRT Rail Vehicle seat.

The Primary data has been collected and gathered by the researcher using the different measurement and observational techniques using rail vehicle seat dimensions. In regarding to the rail vehicles, the data has been collected from Ethiopian Railway Head Office managers and Light Rail Transit project supervisors. The data's are being useful and valuable to analyze the performance and comfort of passenger seats of new light rail bus which has been compared to that

of Addis Ababa anthropometric data of adult people so as to investigate the mismatch even during long-hour sitting.

Table 3.1 Technical data's on Light Rail Vehicles (LRV)

Option1	Total passenger capacity	Passenger	286
	Total seat	Passenger	66
	Fixed seat(Low floor)	Passenger	12
	Fixed seat(High floor)	Passenger	54
	Standees(6 person/m ²)	Passenger	220
Option2	Total passenger capacity	Passenger	306
	Total seat	Passenger	66
	Fixed seat(Low floor)	Passenger	12
	Fixed seat(High floor)	Passenger	54
	Standees(6 person/m ²)	Passenger	240

Table 3.2 The specification data on rail vehicle seating capacity.

Number of passengers(persons)	Seated	Standing	Total
(Aw1) seats	65	0	65
(Aw2) seats	65	189	254
Seating capacity (Standing 6 persons/m ²)			
(Aw3) seats	65	252	317
(Standing 8persons/m ²)			

II. Measurement of Passengers' Anthropometric Dimensions

Anthropometric dimensions (body dimensions) are important to rail bus seat design dealing and analyzing with the human shape to investigate the comfort situation through analyzing software's by using seat dimensional data. The following passenger anthropometric parameters are being considered for ergonomics assessment and investigation of the passenger discomfort parameters, as shown below.

-
- 1-sitting height (SH)
 - 2-sitting to shoulder height (SSH)
 - 3-buttocks to popliteal length (BPL)
 - 4-shoulder breadth (SB)
 - 5-hip breadth seated (HB)

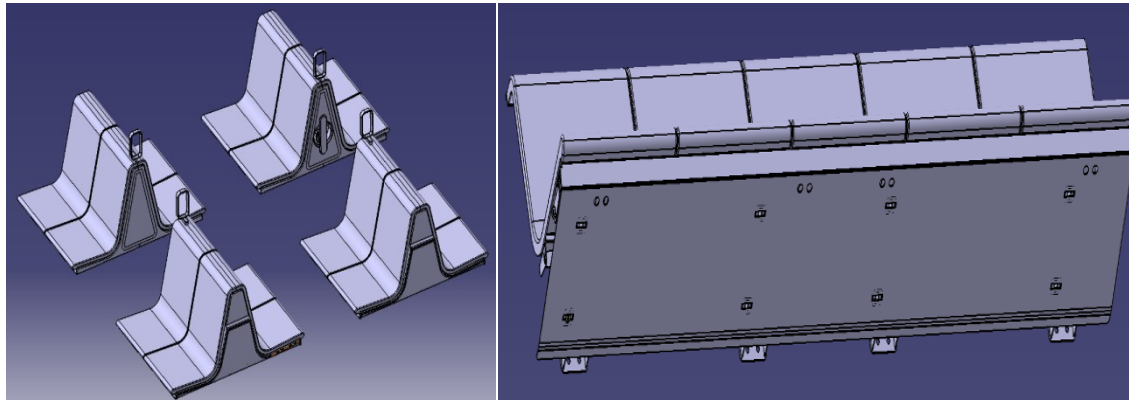

Figure 3.2 Observation measurement of twin passenger and five passenger rail vehicle seat.

The following passenger seat parameters are being measured.

1. Knee height (SH),
2. Back rest height (BH),
3. Seat Depth (SD),
4. Back rest width (BW),
5. Seat width (SW).

3.1.2 Secondary data

The data taken from Ambassador Garment was gathered from October 15/2014 to January 02/2015. December 2014. More than 150 male and female data was gathered from Ambassador Garment from previous study paper. Important data's on body dimension are being referred, some of these are, hip circumference, sleeve length, pant length and thigh circumference and soon. Only Ambassador Garment data is available which makes it only 76 data to be available for the women group. For women anthropometry analysis, most data's was gathered from local tailors.

Ambassador garment was selected because of the following reasons:

-
1. It is one of the major company that sell their product for various customers in the country and their product is affordable for many customers. This makes the data collection to have access to large number of from the population.
 2. Besides the readymade clothes Ambassador garment make, it also take customers body dimension and product per the customer's order. This gives a chance to the researcher for gathering body dimension of city dwellers.
 3. Ambassador garment is a company that products suits, which are the most consistent cloth type in terms of design. This consistency in design enables to get a real measurement of the body dimension, not the cloth dimension.
 4. This company was one of the manufacturers well known cloth dimension in the city.

All data for men is gathered from Ambassador Garment. But it was impossible for women body dimension data. The anthropometric data's have been organized by adding Local tailors around Mercato which is the biggest market in Ethiopia and Cherkos local market for additional data for women postural cloth dimensions. Even though most tailors are not willing, some tailors provided some data which are used for women body measurement.

It is mandatory to equip oneself with the body dimension of local as well as international customers for a garment manufacturer. This is the fact as garment industry has to know the anthropometry of their customers. But as there is no standard that shows the body dimensions of the people in the country typically in Addis Ababa, the industry is facing a challenge in meeting the customers need and meeting the companies target in terms of profit and revenue.

The seat widths would not accommodate adjacent passengers without body contact [12]. This restricts the opportunity for passengers to change posture, not only because of the limited space but also because of the disturbance it may cause the adjacent passenger. Therefore, passenger seat

anthropometric measurement should be designed using measurement as shown in the figure below.

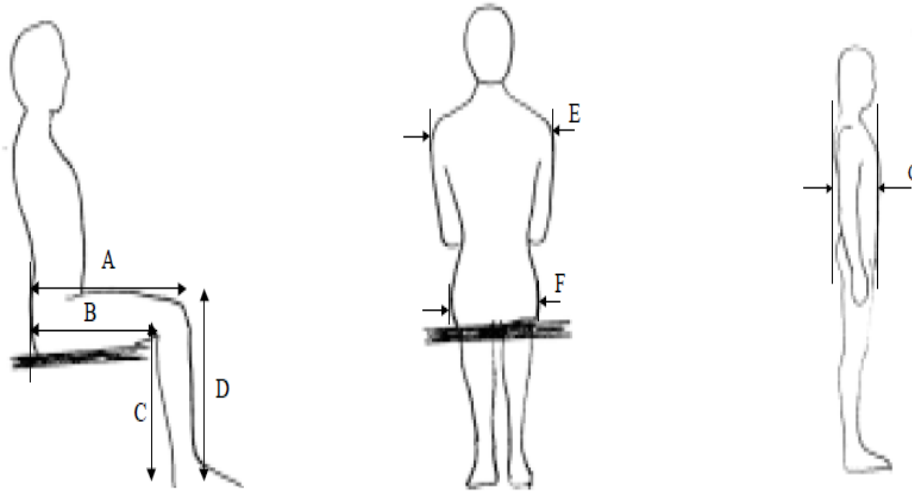

Figure 3.3 Passenger seat anthropometric measurements

- A, Buttock knee length
- B, Buttock popliteal length
- C, Popliteal Height
- D, Knee height
- D, Bideltoid shoulder width
- E, Hip breadth
- G, Whole depth

Table 3.3 The number of data observed in recent research paper.

Category	Shoulder to hip length	Shoulder	Sleeve height	Chest Circ	Waist Circ	Hip Circ	Thigh Circu
Men	1708	1707	1702	1622	1707	1706	1704
Women	78	547	75	603	725	718	73

3.2 Methodology of the Study

The sampling data was analyzed using descriptive statistics such as means, variance standard deviation and anthropometric percentages and measurement using engineering techniques and standard anthropometric tables and/or statistical approaches.

Even though questionnaire is not being accepted by the concerned body, the researcher has considered sufficient data using face to face interview, observation and also by measurement.

Measuring instruments like, calipers and meter has been used using for seating dimensions on rail buses under varying circumstances such as ergonomics comfort assessment such as, over all seating dimensions, seat gap, seat width, backrest height, backrest width, seat depth, aisle space inside rail buses

Systematic sampling is also called an nth name selection technique had been used for predicting passenger standing and allocations using multiple regression model of anthropometric variables. After the required sample size has been calculated, every nth record is selected from a list of population clothing dimensions. As long as the list does not contain any hidden order, this sampling method is as good as the random sampling method. Its only advantage over the random sampling technique is simplicity. Systematic sampling is being used to select a specified number of records from a recent study paper.

3.3 Data analysis

The data has been analyzed using descriptive statistics of sample means, sample standard deviations and using percentiles of fifth, seventy fifth and ninety-fifth value. These percentiles are analyzed using statistical bases of anthropometric formula to develop appropriate percentage of each body dimension of Addis Ababa adult population. The output of this table in the cumulative percentage will show the 5th, 75th, 95th and percentile of the parameter for each group that is Men and Women.

To get the above percentiles the method of data collection are used from recent previous literatures of adult's populations of Addis Ababa.

In this research paper I have used a methodology of interpreting a statistical engineering 5th, 75th 95th and percentile of the Addis Ababa adult people of human posture dimension for each group that is Men and Women by first calculating the sample mean and sample standard deviation using **Engineering Anthropometric Table**. This table is used since it determines standard normal values for computing the commonly used percentiles

The variables which are calculated from the standard table interpretation and calculations of anthropometric dimensions have been compared with the relevant dimensions of the rail vehicles

seats dimensions using independent samples T-test (2-tailed) and chi-square at 95 percent level of confidence using social packages for social science software (SPSS).

Table 3.4 Addis Ababa Adult anthropometric Data-Men shoulder breadth.

Shoulder Breadth(cm)	Frequency(fi)	Mid Interval	fi*mi	X ²	fx ²
39-42	22	40.5	891	1640.25	36085.5
42-45	97	43.5	4219.5	1892.25	183548.25
45-49	65	47	3055	2209	143585
49-54	13	51.5	669.5	2652.25	34479.25
54-58	36	56	2016	3136	112896
58-64	5	61	305	3721	18605

Frequency= 238

Sum of fi*mi=11156

Estimated sample mean (\bar{X}) will be $\frac{\sum fi*mi}{\sum fi} = \bar{X} = 11156 / 238 = 46.9$

Variance (σ^2) = $\frac{\sum fx^2}{n} - \bar{X}^2$

= $\frac{529199}{238} - (46.9)^2 = 2223.52 - 2199.61 = 23.91$

Sample standard deviation (S) = $\sqrt{23.91} = 4.9$

As known from the statistical basis of anthropometry, $X_p = \bar{X} + Z_p \cdot S$

Where, \bar{X} = sample mean.

X_p = P_{th} percentile value of the variable x.

Z_p = Standard normal value corresponding to the P_{th} percentile value of x.

S = sample standard deviation.

Statistical Basis of Anthropometry

$$X_p = \bar{X} + z_p \cdot S$$

Where:

\bar{X} = sample mean

S = sample standard deviation

X_p = P_{th} percentile value of the variable x

Z_p = Standard normal value corresponding to the P_{th} percentile value of x.

Table 3.5 Engineering Anthropometry and Standard measurement of statistics.

Percentile	0.5th	1st	2.5th	5th	10th	16.5th	25th
(p)	0.005	0.01	0.025	0.05	0.10	0.165	0.25
Z_p	-2.575	-2.327	-1.960	-1.645	-1.282	-0.974	-0.675
Percentile	75th	83.5th	90th	95th	97.5th	99th	99.5th
(p)	0.75	0.835	0.90	0.95	0.975	0.99	0.995
Z_p	0.675	0.974	1.282	1.645	1.960	2.327	2.575

From the statistical basis of anthropometry, we can determine the P_{th} percentile value of the variable x for all possible 5th, 75th 95th and percentile of the parameter for each group that is Men and Women.

The P_{th} percentile value of the variable x for 5th percentile,

$$\bar{X} + Z_p \cdot S = 46.9 + (-1.645) \cdot (4.9) = 38.84$$

The P_{th} percentile value of the variable x for 75th percentile,

$$\bar{X} + Z_p \cdot S = 46.9 + (0.675) \cdot (4.9) = 50.2$$

The P_{th} percentile value for 95th percentile, $\bar{X} + Z_p \cdot S = 46.9 + (1.645) \cdot (4.9) = 54.9$

Table 3.6 Addis Ababa Adult anthropometric Data-Men shoulder to hip.

Shoulder-hip interval (cm)	Frequency	Mid Interval	fi*mi	X²	fx²
50-53	4	51.5	206	2652.25	10609
53-56	7	54.5	381.5	2970.25	20791.75
56-60	21	58	1218	3364	70644
60-64	32	62	1984	3844	123008
64-68	19	66	1254	4356	82764
68-75	5	71.5	357.5	5112.25	25561.2

Frequency=88

Sum of fi*mi=5401

Estimated sample mean (\bar{X}) will be $\frac{\sum fi*mi}{\sum fi} = \bar{X} = 5401 / 88 = 61.4$

Variance (σ^2) = $\frac{\sum fx^2}{n} - \bar{X}^2 = 333377.9 / 88 - 61.4^2 = 3788.4 - 3769.9 = 18.44$

Sample standard deviation (S) = $\sqrt{18.44} = 4.3$

As known from the statistical basis of anthropometry, $X_P = \bar{X} + Z_P .S$

The Pth percentile value of the variable x for 5th percentile,

$$X_P = \bar{X} + Z_P .S = 61.4 + (-1.645) * (4.3) = 54.3$$

The Pth percentile value of the variable x for 75th percentile,

$$\bar{X} + Z_P .S = 61.4 + (0.675) * (4.3) = 64.3$$

The Pth percentile value of the variable x for 95th percentile,

$$\bar{X} + Z_P .S = 61.4 + (1.645) * (4.3) = 68.5$$

Table 3.7 Addis Ababa Adult anthropometric data.

Sleeve length(cm)	Frequency	Mid Interval	f _i *m _i	X ²	f _x ²
49-52	3	50.5	151.5	2550.25	7650.75
53-55	20	54	1080	2916	58320
56-60	521	58	30218	3364	1752644
61-64	830	62.5	51875	3906.25	3242187.5
65-68	311	66.5	20681.5	4422.25	1375319.75
69-73	18	71	1278	5041	90738

Frequency= 1703

Sum of f_i*m_i=105284

Estimated sample mean (\bar{X}) will be $\frac{\sum f_i * m_i}{\sum f_i} = \bar{X} = 105284/1703 = 61.8$

Variance (σ^2) = $\frac{\sum f_x^2}{n} - \bar{X}^2$

= $6526860/1703 - (61.8)^2 = 3832.6 - 3819.24 = 13.33$ and (S) = $\sqrt{13.33} = 3.65$

The P_{th} percentile value of the variable x for 5th percentile,

$\bar{X} + Z_p .S = 61.8 + (-1.645) * (3.65) = 55.8$

The P_{th} percentile value of the variable x for 75th percentile,

$\bar{X} + Z_p .S = 61.8 + (0.675) * (3.65) = 64.3$

The P_{th} percentile value of the variable x for 95th percentile,

$\bar{X} + Z_p .S = 61.8 + (1.645) * (3.65) = 67.8$

Table 3.8 Addis Ababa Adult anthropometric data table-men, waist circumference.

Waist Circ (cm)	Frequency	Mid Interval	f _i *m _i	X ²	f _x ²
70-73	7	71.5	500.5	5112.25	35785.75
74-77	28	75.5	2114	5700.25	159607
78-81	144	79.5	11448	6320.25	910116
82-86	283	84	23772	7056	1996848
87-91	399	89	35511	7921	3160479
92-97	465	94.5	43942.5	8930.25	4152566.25

Frequency= 1326

Sum of f_i*m_i=117288

Estimated sample mean (\bar{X}) will be $\frac{\sum f_i \cdot m_i}{\sum f_i} = \bar{X} = 117288/1326 = 88.4$

Variance (σ^2) = $\frac{\sum f_x^2}{n} - \bar{X}^2$

= $10415402/1326 - (88.4)^2 = 7854.75 - 7814.6 = 40.15$ and (S) = $\sqrt{40.15} = 6.33$

The Pth percentile value of the variable x for 5th percentile,

$\bar{X} + Z_p \cdot S = 88.4 + (-1.645) \cdot (6.33) = 77.9$

The Pth percentile value of the variable x for 75th percentile,

$\bar{X} + Z_p \cdot S = 88.4 + (0.675) \cdot (6.33) = 92.7$

The Pth percentile value of the variable x for 95th percentile,

$\bar{X} + Z_p \cdot S = 88.4 + (1.645) \cdot (6.33) = 98.8$

Table 3.9 Addis Ababa Adult anthropometric Data table Men shoulder-breadth length.

Shoulder breadth interval(cm)	Frequency(fi)	Mid Interval(x)	fi*mi	X ²	fx ²
80-83	6	81.5	489	6642.25	39853.5
84-87	46	85.5	3933	336271.5	15468489
88-92	264	90	23760	8100	2138400
93-97	749	95	71155	9025	6759725
98-103	527	100.5	52963.5	10100.25	5322831.75
104-108	75	106	7950	11236	842700

Frequency=1667

$$\sum fi*mi=160250.5$$

Estimated sample mean (\bar{X}) will be $\frac{\sum fi*m}{\sum fi} = \bar{X} = 160250.5 / 1667 = 96.1$

$$\text{Variance } (\sigma^2) = \frac{\sum fx^2}{n} - \bar{X}^2 = \frac{30571999.25}{1667} - (96.1)^2 = 18339.5 - 9235.2 = 9104.3$$

$$(S) = \sqrt{9104.3} = 95.4$$

The Pth percentile value of the variable x for 5th percentile,

$$\bar{X} + Z_p .S = 96.1 + (-1.645)*(95.4) = -60.8$$

The Pth percentile value of the variable x for 75th percentile,

$$\bar{X} + Z_p .S = 96.1 + (0.675)*(95.4) = 160.5$$

The Pth percentile value of the variable x for 95th percentile,

$$\bar{X} + Z_p .S = 96.1 + (1.645)*(95.4) = 25$$

Table 3.10 Addis Ababa Adult anthropometric Data table-men Waist to knee point length.

Waist to knee point (cm)	Frequency	Mid Interval	fi*mi	X ²	fx ²
35-37	8	36	288	1296	10368
37-40.5	193	38.75	7478.75	1501.56	289801.1
41-42.5	556	41.75	23213	1743.06	969141.4
43-44	469	43.5	20401.5	1892.25	887465.25
44.5-45	190	44.75	8502.5	2002.56	380486.4
45-46.5	286	45.75	13084.5	2093.06	598615.2

The above data has been calculated using a standard formula (Total length/2 -2inch or 5cm) used by ambassador garment to get knee point measurement based on the above waist to ankle data measurement on recent study paper.

$$\text{Frequency}=1702$$

$$\sum fi*mi=72968.25$$

$$\text{Estimated sample mean } (\bar{X}) \text{ will be } \frac{\sum fi*m}{\sum fi} = \bar{X} = \frac{72968.25}{1702} = 42.87$$

$$\text{Variance } (\sigma^2) = \frac{\sum fx^2}{n} - \bar{X}^2 = \frac{3135877.4}{1702} - (42.87)^2 = 1842.5 - 1837.8 = 4.7$$

$$(S) = \sqrt{4.7} = 2.17$$

The Pth percentile value of the variable x for 5th percentile,

$$\bar{X} + Z_p .S = 42.87 + (-1.645) * (2.17) = 39.3$$

The Pth percentile value of the variable x for 75th percentile,

$$\bar{X} + Z_p .S = 42.87 + (0.675) * (2.17) = 44.33$$

The Pth percentile value of the variable x for 95th percentile,

$$\bar{X} + Z_p .S = 42.87 + (1.645) * (2.17) = 46.44$$

Table 3.11 Addis Ababa Adult anthropometric Data table Men knee point to ankle length.

The above data has been calculated using the increment of 2.5cm for shoes thickness.

Knee point to ankle length (cm)	Frequency(fi)	Mid Interval(x)	fi*mi	X²	fx²
45-46	4	45.5	182	2070.25	8281
46.5-47.5	23	47	1081	2209	50807
48-49.5	129	48.75	6288.75	2376.6	306581.4
50-51.5	450	50.75	22837.5	2575.6	1159020
52-53.5	281	52.75	14822.75	2782.6	781910.6
54-55	190	54.5	10355	2970.25	564347.5

Frequency=1077

$\sum fi*mi=55567$

Estimated sample mean (\bar{X}) will be $\frac{\sum fi*m}{\sum fi} = \bar{X} = 55567/1077 = 51.6$

Variance (σ^2) = $\frac{\sum fx^2}{n} - \bar{X}^2 = 2870947.5 / 1077 - (51.6)^2 = 2665.7 - 2662.56 = 3.14$

(S) = $\sqrt{3.14} = 1.77$

The Pth percentile value of the variable x for 5th percentile,

$\bar{X} + Z_p .S = 51.6 + (-1.645) * (1.77) = 48.7$

The Pth percentile value of the variable x for 75th percentile,

$\bar{X} + Z_p .S = 51.6 + (0.675) * (1.77) = 52.8$

The Pth percentile value of the variable x for 95th percentile,

$\bar{X} + Z_p .S = 51.6 + (1.645) * (1.77) = 54.51$

Table 3.12 Addis Ababa Adult anthropometric data table-men Hip circumference.

Hip Circ (cm)	Frequency	Mid Interval	fi*mi	X ²	fx ²
72-79	5	75.5	377.5	5700.25	28501.25
80-88	16	84	1344	7056	112896
89-92	66	90.5	5973	8190.25	540556.5
93-97	217	95	20615	9025	1958425
98-103	455	100.5	45727.5	10100.25	4595613.75
104-107	375	105.5	39562.5	11130.25	4173843.75

Since the hip circumference data has been used, in order to interpret sample mean and standard deviation and half of the mean and standard deviation on hip breadth (HB) is being considered.

Frequency= 1134

$\sum fi*mi=11409836.25$

Estimated sample mean (\bar{X}) will be $\frac{\sum fi*m}{\sum fi} = \bar{X} = 113599.5/1134=100$

Variance (σ^2) = $\frac{\sum fx^2}{n} - \bar{X}^2 = 11409836.25/1134 - (100.2)^2 = 10061.6 - 10040.04 = 21.56$,

(S) = $\sqrt{21.56} = 4.64$

The Pth percentile value of the variable x for 5th percentile,

$\bar{X} + Z_p .S = 50 + (-1.645)*(2.32) = 46.1$

The Pth percentile value of the variable x for 75th percentile,

$\bar{X} + Z_p .S = 50 + (0.675)*(2.32) = 51.55$

The Pth percentile value of the variable x for 95th percentile,

$\bar{X} + Z_p .S = 50 + (1.645)*(2.32) = 53.82$

Table 3.13 Addis Ababa Adult anthropometric data table-men Thigh circumference.

Thigh Circ(cm)	Frequency	Mid Interval	fi*mi	X²	fx²
47-51	3	49	147	2401	7203
52-56	19	54	1026	2916	55404
57-61	166	59	9794	3481	577846
62-66	433	64	27712	4096	1773568
67-73	762	70	53340	4900	3733800
74-78	410	76	31160	5776	2368160

Frequency= 1793

$\sum fi*mi=123179$

Estimated sample mean (\bar{X}) will be $\sum fi*m / \sum fi = \bar{X} = 123179/1793=68.7$

Variance (σ^2) = $\sum fx^2/n - \bar{X}^2 = 8515981/1793 - (68.7)^2 = 4749.6 - 4719.7 = 29.91$

(S) = $\sqrt{29.91}=5.47$

$\bar{X} + Z_p .S = 68.7 + (-1.645)*(5.47) = 59.7$

The Pth percentile value of the variable x for 5th percentile,

$\bar{X} + Z_p .S = 68.7 + (-1.645)*(5.47) = 59.7$

The Pth percentile value of the variable x for 75th percentile,

$\bar{X} + Z_p .S = 68.7 + (0.675)*(5.47) = 72.4$

The Pth percentile value of the variable x for 95th percentile,

$\bar{X} + Z_p .S = 68.7 + (1.645)*(5.47) = 77$

Table 3.14 Addis Ababa Adult anthropometric Data table-Women shoulder to hip length.

Shoulder to hip interval(cm)	Frequency	Mid Interval	fi*mi	X²	fx²
50-53	4	51.5	206	2652.25	10609
53-56	8	54.5	436	2970.25	23762
56-60	21	58	1218	3364	70644
60-64	34	62	2108	3844	130696
64-68	19	66	1254	4356	82764
68-72	3	70	210	4900	14700

Frequency= 89

$$\sum fi*mi=5432$$

Estimated sample mean (\bar{X}) will be $\frac{\sum fi*m}{\sum fi} = \bar{X}=5432 /89= 61$

$$\text{Variance } (\sigma^2) = \frac{\sum fx^2}{n} - \bar{X}^2 = \frac{333175}{89} - (62.9)^2 = 3743.54 - 3721 = 22.54$$

$$(S) = \sqrt{22.54} = 4.75$$

The P_{th} percentile value of the variable x for 5th percentile,

$$\bar{X} + Z_p .S = 61 + (-1.645) * (4.75) = 53.2$$

The P_{th} percentile value of the variable x for 75th percentile,

$$\bar{X} + Z_p .S = 61 + (0.675) * (4.75) = 64.2$$

The P_{th} percentile value of the variable x for 95th percentile,

$$\bar{X} + Z_p .S = 61 + (1.645) * (4.75) = 68.81$$

Table 3.15 Addis Ababa Adult anthropometric Data table-women shoulder breadth

Shoulder breadth(cm)	Frequency	Mid Interval	fi*mi	X²	fx²
30-34	5	32	160	1024	5120
35-38	136	36.5	4964	1332.25	181186
39-42	336	40.5	13608	1640.25	551124
43-46	61	44.5	2714.5	1980.25	120795.25
47-50	6	48.5	291	2352.25	14113.5
51-53	1	52	52	2704	2704

Frequency= 545

$\sum fi*mi=21789.5$

Estimated sample mean (\bar{X}) will be $\frac{\sum fi*m}{\sum fi} = \bar{X} = 21789.5/545 = 39.9$

Variance (σ^2) = $\frac{\sum fx^2}{n} - \bar{X}^2 = 875042.75/545 - (39.9)^2 = 1605.6 - 1592 = 13.6$

(S) = $\sqrt{13.6} = 3.7$

The Pth percentile value of the variable x for 5th percentile,

$\bar{X} + Z_p .S = 39.9 + (-1.645)*(3.7) = 33.81$

The Pth percentile value of the variable x for 75th percentile,

$\bar{X} + Z_p .S = 39.9 + (0.675)*(3.7) = 42.4$

The Pth percentile value of the variable x for 95th percentile,

$\bar{X} + Z_p .S = 39.9 + (1.645)*(3.7) = 46$

Table 3.16 Addis Ababa Adult anthropometric Data table-women sleeve length.

Sleeve length (cm)	Frequency(fi)	Mid Interval(x)	fi*mi	X ²	fx ²
44-47	1	45.5	45.3	2070.25	2070.25
48-50	1	49	49	2401	2401
51-55	27	53	1431	2809	75843
56-58	30	57	1710	3249	97470
59-60	12	59.5	714	3540.25	42483
61-63	2	62	124	3844	7688

Frequency=73

$$\sum fi*mi=4073.3$$

Estimated sample mean (\bar{X}) will be $\sum fi*m / \sum fi = \bar{X}=4073.3 / 73= 55.8$

$$\text{Variance } (\sigma^2) = \sum fx^2/n - \bar{X}^2 = 227955.25/73 - (55.8)^2 = 3122.7 - 3113.64 = 9.06$$

$$(S) = \sqrt{9.06} = 3.01$$

The Pth percentile value of the variable x for 5th percentile,

$$\bar{X} + Z_p .S = 55.8 + (-1.645)*(3.01) = 50.85$$

The Pth percentile value of the variable x for 75th percentile,

$$\bar{X} + Z_p .S = 55.8 + (0.675)*(3.01) = 57.83$$

The Pth percentile value of the variable x for 95th percentile

$$\bar{X} + Z_p .S = 55.8 + (1.645)*(3.01) = 60.75$$

Table 3.17 Addis Ababa Adult anthropometric Data table, Women waist circumference.

Waist Circ(cm)	Frequency(fi)	Mid Interval(x)	fi*mi	X ²	fx ²
50-53	3	51.5	154.5	2652.25	7956.75
54-57	1	55.5	55.5	3080.25	3080.25
58-62	7	60	420	3600	25200
63-66	14	64.5	903	4160.25	58243.5
67-72	44	69.5	3049.2	4830.25	212531
73-79	99	76	7524	5776	571824

Frequency=168

$$\sum fi*mi=12106.273$$

Estimated sample mean, \bar{X} will be $\frac{\sum fi*m}{\sum fi} = \bar{X} = 12106.27/168 = 72$

$$\text{Variance } (\sigma^2) = \frac{\sum fx^2}{n} - \bar{X}^2 = 878835.5/168 - (72)^2 = 5231.2 - 5184 = 47.2$$

$$(S) = \sqrt{47.2} = 6.9$$

The Pth percentile value of the variable x for 5th percentile,

$$\bar{X} + Z_p .S = 72 + (-1.645) * (6.9) = 60.65$$

The Pth percentile value of the variable x for 75th percentile,

$$\bar{X} + Z_p .S = 72 + (0.675) * (6.9) = 76.6$$

The Pth percentile value of the variable x for 95th percentile,

$$\bar{X} + Z_p .S = 72 + (1.645) * (6.9) = 83.35$$

Table 3.18 Addis Ababa Adult anthropometric Data table, Women Hip circumference.

Hip Circ (cm)	Frequency(fi)	Mid Interval(x)	f_i*m_i	X²	f_x²
61-65	4	63	252	3969	15876
66-69	2	67.5	135	4556.25	9112.5
70-74	2	72	144	5184	10368
75-79	2	77	154	5929	11858
80-89	30	84.5	2535	7140.25	214207.5
90-94	29	92	2668	8464	245456

Frequency=69

$$\sum f_i * m_i = 5888$$

Estimated sample mean (\bar{X}) will be $\frac{\sum f_i * m_i}{\sum f_i} = \bar{X} = 5888/69 = 85.333$

$$\text{Variance } (\sigma^2) = \frac{\sum f_x^2}{n} - \bar{X}^2 = \frac{506878}{69} - (85.3)^2 = 7346.06 - 7276.1 = 69.96$$

$$(S) = \sqrt{69.96} = 8.4$$

The P_{th} percentile value of the variable x for 5th percentile,

$$\bar{X} + Z_p .S = 42.65 + (-1.645) * (4.2) = 35.74$$

The P_{th} percentile value of the variable x for 75th percentile,

$$\bar{X} + Z_p .S = 42.65 + (0.675) * (4.2) = 45.5$$

The P_{th} percentile value of the variable x for 95th percentile,

$$\bar{X} + Z_p .S = 42.5 + (1.645) * (4.2) = 49.41$$

Table 3.19 Addis Ababa Adult anthropometric Data table, Women Thigh circumference.

Thigh Circ (cm)	Frequency	Mid Interval	fi*mi	X ²	fx ²
44-48	6	46	276	2116	12696
49-53	14	51	714	2601	36414
54-58	18	56	1008	3136	56448
59-64	11	61.5	676.5	3782.5	41604.5
65-71	17	68	1156	4624	78608
72-77	5	74.5	372.5	5550.5	27751.5

Frequency=71

$$\sum fi*mi=4203$$

Estimated sample mean (\bar{X}) will be $\sum fi*m / \sum fi = \bar{X}=4203/71=59.2$

$$\text{Variance } (\sigma^2) = \sum fx^2/n - \bar{X}^2 = 253522/71 - (59.2)^2 = 3570.73 - 3504.64 = 66.1$$

$$(S) = \sqrt{66.1} = 8.12$$

The Pth percentile value of the variable x for 5th percentile,

$$\bar{X} + Z_p .S = 59.2 + (-1.645)*(8.12) = 45.8$$

The Pth percentile value of the variable x for 75th percentile,

$$\bar{X} + Z_p .S = 59.2 + (0.675)*(8.12) = 64.7$$

The Pth percentile value of the variable x for 95th percentile,

$$\bar{X} + Z_p .S = 59.2 + (1.645)*(8.12) = 72.5$$

Table 3.20 Addis Ababa Adult anthropometric Data table, Women, buttock to knee point.

Buttock- Knee interval(cm)	Frequency	Mid Interval(x)	fi*mi	X ²	fx ²
32-34	1	33	33	1089	1089
34.5-36	0	35.25	0	1242.6	0
36.5-39	12	37.75	453	1425.1	17101.2
39.5-41.5	31	40.5	1255.5	1640.25	50847.75
42-43.5	19	42.75	812.25	1827.6	34724.4
44-46	12	45	540	2025	24300

Frequency=75

$\sum fi*mi=3093.75$

Estimated sample mean (\bar{X}) will be $\frac{\sum fi*m}{\sum fi} = \bar{X} = 3093.75/75 = 41.25$

Variance (σ^2) = $\frac{\sum fx^2}{n} - \bar{X}^2 = 128062.35/75 - (41.25)^2 = 1707.5 - 1701.6 = 5.9$

(S) = $\sqrt{5.9} = 2.43$

The Pth percentile value of the variable x for 5th percentile,

$\bar{X} + Z_p .S = 41.25 + (-1.645) * (2.43) = 37.25$

The Pth percentile value of the variable x for 75th percentile,

$\bar{X} + Z_p .S = 41.25 + (0.675) * (2.43) = 42.9$

The Pth percentile value of the variable x for 95th percentile,

$\bar{X} + Z_p .S = 41.25 + (1.645) * (2.43) = 45.24$

Table 3.21 Addis Ababa Adult anthropometric Data table-women knee to ankle point.

Knee - Ankle interval(cm)	Frequency	Mid Interval	f_i*m_i	X²	f_x²
42-45	1	43.75	43.75	1941.1	1941.1
45-47.5	7	46.25	323.75	2139.1	14973.7
48-50.5	12	49.25	591	2425.6	29107.2
51-52.5	20	51.75	1035	2678.1	53256
53-54	15	53.5	802.5	2862.2	42933
54.5-56	6	55.25	331.5	3052.6	18315.6

The above data has been calculated using a standard formula (Total length/2 -2inch or 5cm), for classic (regular) cloth dimensions with the increment of 2.5cm for shoe thickness.

$$\text{Frequency}=61$$

$$\sum f_i * m_i = 3127.25$$

$$\text{Estimated sample mean } (\bar{X}) \text{ will be } \frac{\sum f_i * m_i}{\sum f_i} = \bar{X} = 3127.25 / 61 = 51.2$$

$$\text{Variance } (\sigma^2) = \frac{\sum f_x^2}{n} - \bar{X}^2 = 160526.6 / 61 - (51.2)^2 = 2631.6 - 2621.4 = 10.16 \text{ (S)} = \sqrt{10.16} = 3.19$$

The P_{th} percentile value of the variable x for 5th percentile,

$$X_p = \bar{X} + Z_p . S = 51.2 + (-1.645) * (3.19) = 45.95$$

The P_{th} percentile value of the variable x for 75th percentile,

$$\bar{X} + Z_p . S = 51.2 + (0.675) * (3.19) = 53.35$$

The P_{th} percentile value of the variable x for 95th percentile,

$$\bar{X} + Z_p . S = 51.2 + (1.645) * (3.19) = 56.44$$

3.4 T-test analysis

The t- test was used to assess whether the means of the seat dimensions and the means of the related anthropometric dimensions of rail passenger are statistically different. The t-values were calculated using a formula (pal and sarker, 2006) [3] and the calculated values were compared with the critical t-values, this value is identified by using the Critical Significance Level (α : alpha) chosen and the degrees of freedom calculated using the assumed sample and then will be compared with the value for the t statistic calculated.

I claimed two hypotheses weather to accept or to reject with the sense of passenger comfort evaluation criteria that is, **Null Hypotheses** and **Alternative Hypothesis**. Null Hypothesis would be rejected, if the calculated t-value is greater than or equal to the critical value; $t > t_{\text{critical}}$ (significant result) or Accepted, if the calculated value is less than the critical value; $t < t_{\text{critical}}$

$$t = (\bar{X}_1 - \bar{X}_2) \div \sqrt{(s_1^2/n_1 + s_2^2/n_2)} \dots \dots \dots (1)$$

Where t =t-statistic, \bar{X}_1 = sample-1 mean, \bar{X}_2 =sample-2 mean, s_1 =sample-1 standard deviation, s_2 = sample-2 standard deviation, n_1 = sample-1 size and n_2 = sample-2 size where the t values were calculated using equation 1.Knee height (KH) and seat height:

$$t = (51.6-43) \div \sqrt{(1.77^2/1077+3.77^2/4)} = 4.56$$

Shoulder breadth (SB) and backrest width:

$$t = (46.9-42.8) \div \sqrt{(4.9^2/238+1.19^2/4)} = 6.08$$

Hip breadth (HB) and Seat width:

$$t = (50-43) \div \sqrt{(2.32^2/1134+1.34^2/4)} = 4.3$$

Buttocks to popliteal length (BPL) and seat depth:

$$t = (43.8-42.23) \div \sqrt{(2.17^2/1702+1.19^2/4)} = 2.6$$

Shoulder to hip (SSH) and backrest height: $t = (61.4-50) \div \sqrt{(4.3^2/88+7.8^2/4)} = 2.9$

Table 3.22 T –test analysis of seat dimensions and rail passengers’ anthropometric dimensions.

Anthropometric			Seat dimensions		Difference	t_{calc}	t_{cri}	Decision	
Male Dimensions									
	Mean	SD							
KH	51.6	1.77	Seat height	43	3.77	8.6	4.6	3.182	Reject
HB	50	2.32	Seat width	43	1.34	7	4.3	3.182	Reject
BPL	43.87	2.17	Seat depth	42.23	1.19	1.64	2.6	3.182	Accept
SSH	61.4	4.3	Backrest height	50	7.88	11.4	2.9	3.182	Accept
SB	46.9	4.9	Backrest width	42.8	1.19	4.1	6.1	3.182	Reject

Note: SD- Standard deviation, KH-Knee height, HB-Hip breadth, BPL- Buttocks to popliteal length, SSH-Sitting to shoulder height, SB-Shoulder breadth, t_{calc}–calculated t-value, t_{cri}-critical t-value.

The relevant dimensions of the rail vehicles seats dimensions using independent samples T-test (2-tailed), with significance of $\alpha = 0.05$ with the degrees of freedom 3 is showing the corresponding t -critical value 3.182.

Table 3.23 Table of Critical Values for Critical Significance Levels (α : alphas).

Df	$\alpha = 0.10$	$\alpha = 0.05$	$\alpha = 0.01$
1	6.314	12.706	63.656
2	2.920	4.303	9.925
3	2.353	3.182	5.841
4	2.132	2.776	4.604

Table 3.24 Chi-square statistics(X^2) for related percentages comparison.

Anthropometric dimensions	Values	Percentiles			
		5 th	75 th	95 th	
Knee height Seat height	Observed values(O)	48.7	52.8	54.5	
	Expected values(E)	36.8	45.54	49.2	
	$(O-E)^2 \div E$	3.848	1.157	0.571	5.57
Hip breadth Seat width	Observed values(O)	46.1	51.5	53.8	
	Expected values(E)	40.8	43.9	45.2	
	$(O-E)^2 \div E$	0.688	1.316	1.636	3.64
Buttocks to Popliteal height and Seat depth	Observed values(O)	39.3	44.3	46.4	
	Expected values(E)	41.3	44	45.2	
	$(O-E)^2 \div E$	0.097	0.002	0.032	0.13
Sitting to shoulder height and backrest height	Observed values(O)	38.84	50.2	54.9	
	Expected values(E)	37.04	55.3	62.9	
	$(O-E)^2 \div E$	0.087	0.470	1.017	1.57
Shoulder breadth and backrest width	Observed values(O)	54.3	64.3	68.5	
	Expected values(E)	40.8	43.6	44.7	
	$(O-E)^2 \div E$	37.04	55.3	62.9	29.97

3.5 Chi-Squared Test of Independence

In this research paper, Chi-squared statistical test deals with two categorical variables for testing the goodness of fit, using SPSS (social package for social science selected for statistical analysis). In general, the number of degrees of freedom of chi-square is (number of rows-1)*(number of columns-1) that will give four degrees of freedom for the above table assumption. For the

analysis, two hypotheses were analyzed. Using The Chi-square critical table value become, where $\chi^2 = 9.49$.

We can also test the relation using hypothesis on SPSS output, where the researcher have used two hypotheses, as shown below.

H₀: The observed statistical rail vehicle seat dimensional Problems are related to anthropometric factors.

H_{A1}: The observed statistical rail vehicle seat dimensional Problems are not related to anthropometric factors.

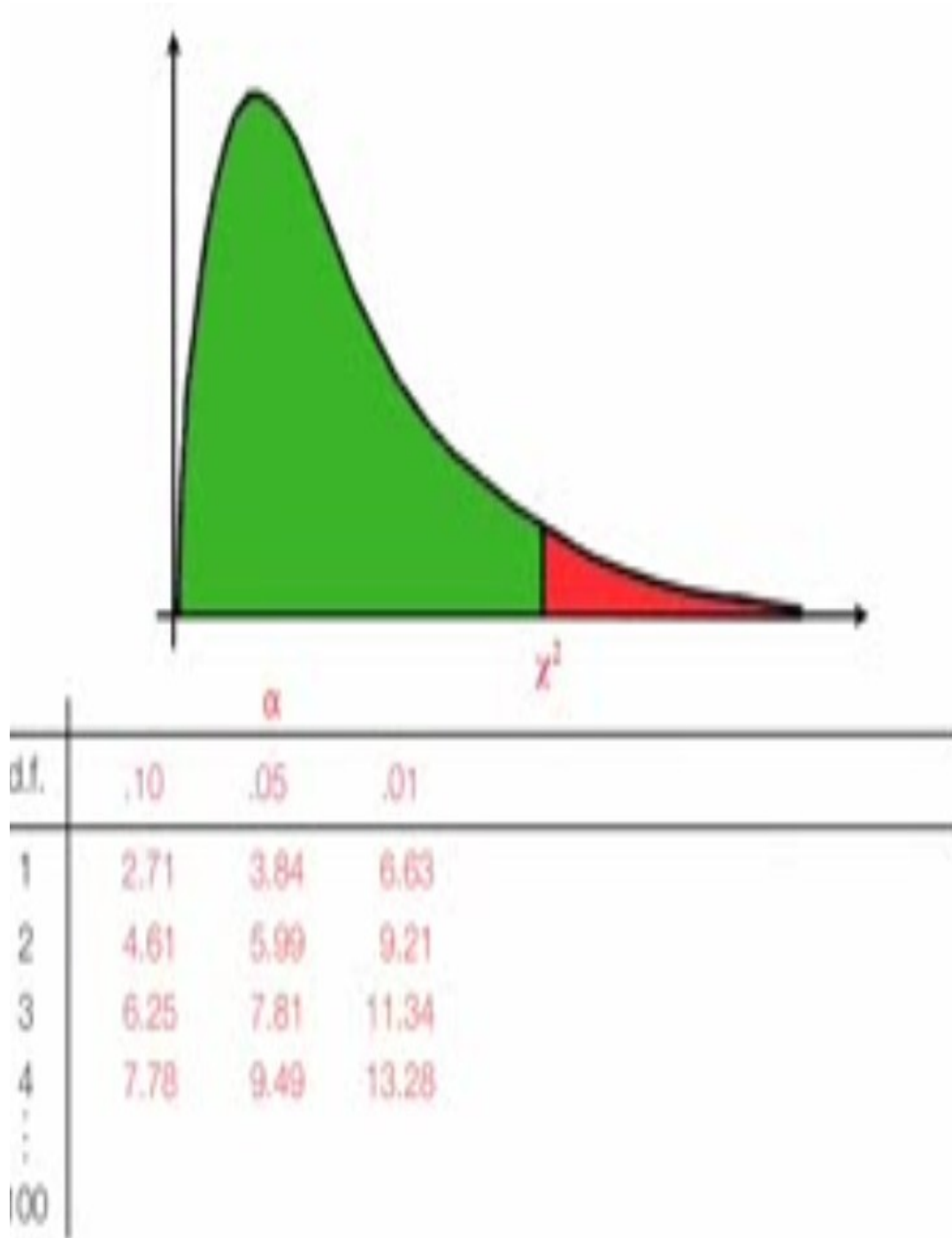

Figure 3.4 Chi-square critical value

Table 3.25 Chi-square test analysis of passengers' male anthropometric and seat dimensions.

Anthropometric Dimensions	Percentiles			Seat Dimensions	Percentiles			X ² Cal	X ² df =4	Decision
	5 th	75	95 th		5 th	75 th	95 th			
KH	45.95	53.35	56.4	Seat height	48.7	52.8	54.5	5.57	9.49	Accept
HB	40.8	43.9	45.2	Seat width	46.1	51.5	53.8	3.64	9.49	Accept
BPL	41.3	44	45.2	Seat depth	39.3	44.3	46.4	0.13	9.49	Accept
SSH	37.04	55.32	62.96	Backrest height	38.8	50.2	54.9	1.57	9.49	Accept
SB	40.85	43.6	44.75	Backrest width	54.3	64.3	68.5	29.97	9.49	Reject

Based on significance level equal to $\alpha = 0.05$, I can accept the null hypothesis, which indicates, there are goodness of fit with a sense of comfort during passengers transportation.

Since 5.57 is less than $9.49_{\chi^2_{critica}}$, therefore, by considering the first case, we can accept the null hypotheses.

Chi-square test analysis of passenger's anthropometric dimensions and vehicles seat dimensions has been important for predicting a better decision. Therefore we can conclude the more target population of anthropometric data is being considered, the more the analysis would be visible through the hypothetical approach.

3.6 Chi Squared tests using SPSS

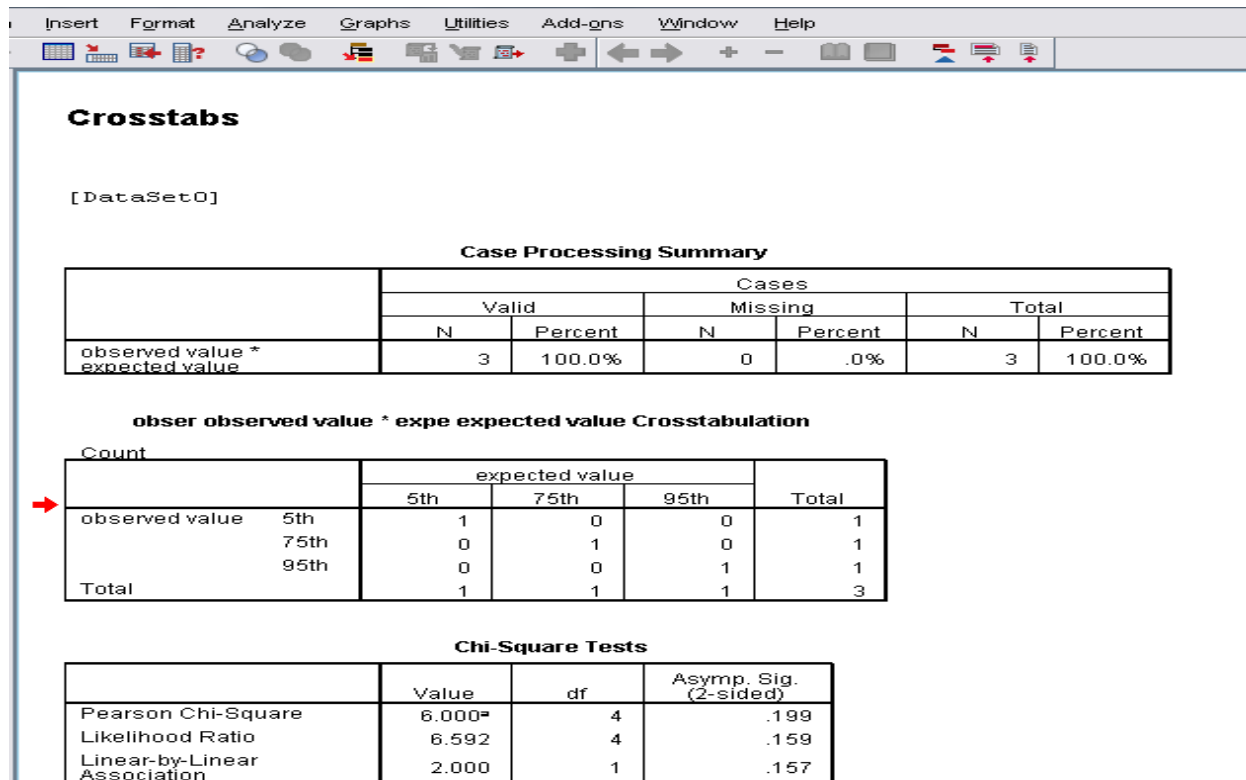

Figure 3.5 SPSS output of Chi Squared Tests

When two samples are involved, the samples can come from different individuals who are not matched (the samples are independent of each other.) Or the sample can come from the same individuals (the samples are paired with each other) and the samples are not independent of each other. The form of the t-test is slightly different for the independent samples and dependent samples types of two sample tests, and SPSS has separate procedures for performing the two types of tests.

As per chi-square test on SPSS figure 3.6, we fail to reject, the null hypothesis, Since the p-value which is 0.199 is greater than .05 (based on 0.05 significance level), therefore and we can conclude that the anthropometric dimension of the target population’s knee height and the rail vehicles seat height are related with the sense of comfort. Therefore, the decision is the same as the one which has been made above in table 3.25.

Table 3.26 Chi-square test analysis of passenger’s female anthropometric and seat dimensions.

Anthropometric Dimensions	Percentiles			Seat Dimensions	Percentiles			X ² Cal	X ² df =4	Decision
	5 th	75	95 th		5 th	75 th	95 th			
KH	45.95	53.35	56.4	Seat height	48.7	52.8	54.51	4.66	9.49	Accept
HB	45.9	53.5	56.4	Seat width	46.1	51.5	53.82	5.51	9.49	Accept
BPL	37.25	42.9	45.2	Seat depth	39.3	44.3	46.44	0.42	9.49	Accept
SSH	53.2	64.2	68.8	Backrest height	38.8	50.2	54.9	1.54	9.49	Accept
SB	33.8	42.4	46.0	Backrest width	54.3	64.3	68.5	1.27	9.49	Accept

3.7 Evaluation of Passenger rail vehicle seat dimensions

The researcher used four observational assessments the statistical mean absolute deviations and standard deviation. During data observation on different dimensions of passenger seat design on each ergonomic assessment of passenger rail vehicle seat, there are different dimensions on seats chair since there are a twin passenger seat and five passenger seats, due to this reason the dimensional data’s vary in most of seating and space measurement. Therefore it was necessary to investigate the mean absolute dimensional value and standard deviation of each dimensions using repetitive measurement.



Figure 3.6 Evaluation of Passenger rail vehicle seat dimensions.

Table 3.27 Sample of observations in existing seat height.

X_i	$X_i - \bar{X}$	$(X_i - \bar{X})^2$
39.8	$39.3 - 43 = -3.7$	$(-3.7)^2$
40	$40 - 43 = -3$	$(-3)^2$
46.3	$46.3 - 43 = 3.3$	$(3.3)^2$
46	$46 - 43 = 3$	$(3)^2$

Sample mean, $\bar{X} = 43$

Mean absolute deviations,

$$\text{MAD} = \sum |X_i - \bar{X}| / N = 13/4 = 3.25$$

$$S^2 = \sum (X_i - \bar{X})^2 / (N-1) = 42.58/3 = 14.2, \quad S = \sqrt{14.2} = 3.77$$

The Pth percentile value of the variable x for 5th percentile,

$$\bar{X} + Z_p \cdot S = 43 + (-1.645) \cdot (3.77) = 36.88$$

The Pth percentile value of the variable x for 75th percentile,

$$\bar{X} + Z_p \cdot S = 43 + (0.675) \cdot (3.77) = 45.54$$

The Pth percentile value of the variable x for 95th percentile,

$$\bar{X} + Z_p \cdot S = 43 + (1.645) \cdot (3.77) = 49.2$$

Table 3.28 Sample of four observations in existing seat width.

X_i	$X_i - \bar{X}$	$(X_i - \bar{X})^2$
41.7	41.7-43 = -1.3	$(-1.3)^2$
41.7	41.7-43 = -1.3	$(-1.3)^2$
42	42-43 = -1	$(-1)^2$
44	44-43 = 1	$(1)^2$
44.3	44.3-43 = 1.3	$(1.3)^2$

Sample mean $\bar{X} = 43$

$$\text{MAD} = \sum |X_i - \bar{X}| / N = 4.6/4 = 1.15$$

$$S^2 = \sum (X_i - \bar{X})^2 / (N-1) = 5.83/3 = 1.94, \quad S = \sqrt{1.94} = 1.39$$

The Pth percentile value of the variable x for 5th percentile,

$$\bar{X} + Z_p .S = 43 + (-1.645) * (1.34) = 40.8$$

The Pth percentile value of the variable x for 75th percentile,

$$X_p = \bar{X} + Z_p .S = 43 + (0.675) * (1.34) = 43.9$$

The Pth percentile value of the variable x for 95th percentile,

$$\bar{X} + Z_p .S = 43 + (1.645) * (1.34) = 45.2$$

Table 3.29 Sample of four observations in existing seat depth.

X_i	$X_i - \bar{X}$	$(X_i - \bar{X})^2$
42	42 - 43.25 = -1.25	$(-1.25)^2$
42.5	42.5 - 43.25 = -0.75	$(-0.75)^2$
44	44 - 43.25 = 0.75	$(0.75)^2$
44.5	44.5 - 43.25 = 1.25	$(1.25)^2$

Sample mean is 43.25

$$MAD = \sum |X_i - \bar{X}| / N = 4/4 = 1.0$$

$$S^2 = \sum (X_i - \bar{X})^2 / N - 1 = 4.25/3 = S = \sqrt{1.41} = 1.19$$

The Pth percentile value of the variable x for 5th percentile,

$$\bar{X} + Z_p .S = 43.25 + (-1.645) * (1.19) = 41.3$$

The Pth percentile value of the variable x for 75th percentile,

$$\bar{X} + Z_p .S = 43.25 + (0.675) * (1.19) = 44$$

The Pth percentile value of the variable x for 95th percentile,

$$\bar{X} + Z_p .S = 43.25 + (1.645) * (1.19) = 45.2$$

Table 3.30 Sample of four observations for backrest height.

X_i	$X_i - \bar{X}$	$(X_i - \bar{X})^2$
43	$43 - 50 = -7$	$(-7)^2$
43.4	$43.4 - 50 = -6.6$	$(-6.6)^2$
56.7	$56.7 - 50 = 6.7$	$(6.7)^2$
57	$57 - 50 = 7$	$(7)^2$

Sample mean $\bar{X} = 50$

$$\text{MAD} = \sum |X_i - \bar{X}| / N = 27.3 / 4 = 6.82$$

$$S^2 = \sum (X_i - \bar{X})^2 / N - 1 = 186.45 / 3, S = \sqrt{62.15} = 7.88$$

The P_{th} percentile value of the variable x for 5th percentile,

$$\bar{X} + Z_p \cdot S = 50 + (-1.645) \cdot (7.88) = 37.04$$

The P_{th} percentile value of the variable x for 75th percentile,

$$\bar{X} + Z_p \cdot S = 50 + (0.675) \cdot (7.88) = 55.32.$$

The P_{th} percentile value of the variable x for 95th percentile,

$$\bar{X} + Z_p \cdot S = 50 + (1.645) \cdot (7.88) = 62.96$$

Table 3.31 Sample of four observations for backrest width.

X_i	$X_i - \bar{X}$	$(X_i - \bar{X})^2$
41.7	$41.7 - 42.8 = -1.1$	$(-1.1)^2$
42	$42 - 42.8 = -0.8$	$(-0.8)^2$
43.8	$43.8 - 42.8 = 1$	$(1)^2$
44	$44 - 42.8 = 1.2$	$(1.2)^2$

Sample mean $\bar{X} = 42.8$, $\text{MAD} = \sum |X_i - \bar{X}| / N = 4.1 / 4 = 1.03$

$$S^2 = \sum (X_i - \bar{X})^2 / N - 1 = 4.29 / 3, S = \sqrt{1.43} = 1.19$$

The Pth percentile value of the variable x for 5th percentile,

$$\bar{X} + Z_p \cdot S = 42.8 + (-1.645) \cdot (1.19) = 40.85$$

The Pth percentile value of the variable x for 75th percentile,

$$\bar{X} + Z_p \cdot S = 42.8 + (0.675) \cdot (1.19) = 43.6$$

The Pth percentile value of the variable x for 95th percentile,

$$\bar{X} + Z_p \cdot S = 42.8 + (1.645) \cdot (1.19) = 44.75$$

Table 3.32 Dimensions of existing passenger seat of new rail vehicle.

Seat dimensions	Percentiles				
	Mean	SD	5 th	75 th	95 th
Seat height	43	3.77	36.8	45.54	49.2
Seat width	43	1.34	40.8	43.9	45.2
Seat depth	42.23	1.19	41.3	44	45.2
Backrest height	50	7.88	37.04	55.32	62.96
Backrest width	42.8	1.19	40.85	43.6	44.75
Note: SD- Standard deviation					

Table 3.33 Summary of the Anthropometric Dimensions for male.

Anthropometric dimensions	Percentiles				
	Mean	SD	5th	75th	95th
KH	51.2	3.19	45.95	53.35	56.4
HB	42.65	4.2	45.9	53.5	56.4
BPL	41.25	2.43	37.25	42.9	45.2
SB	39.9	3.7	33.8	42.4	46.0
SSH	61	4.75	53.2	64.2	68.8

Note: SD- Standard deviation, KH-Knee height, HB-Hip breadth, BPL- Buttocks to popliteal length, SB-Shoulder breadth, SSH-Sitting to shoulder height.

Table 3.34 Summary of the Anthropometric Dimensions for female.

Anthropometric dimensions	Percentiles				
	Mean	SD	5th	75th	95th
KH	51.6	1.77	48.7	52.8	54.51
HB	50	2.32	46.1	51.5	53.82
BPL	43.87	2.17	39.3	44.3	46.44
SB	46.9	4.9	38.84	50.2	54.9
SSH	61.4	4.3	54.3	64.3	68.5

CHAPTER FOUR

DEVELOPMENT OF STATISTICAL PREDICTION MODEL

4.1 INTRODUCTION

Multiple regression analysis is an appropriate method when the research problem includes one unique metric dependent variable that is related to more than one metric-independent variable. The general purpose of the multiple regression analysis is to learn about the relationship between several independent or predictor variables and a dependent or criterion variable. Multiple regression analysis can be generally represented in the following form:

$$Y = b_0 + b_1X_1 + b_2X_2 + b_3X_3 + \dots + b_nX_n$$

Where, Y is the predicted score or the estimated value and represents the dependent variable. X₁, X₂..., X_n are measures of distinguishable variables that may help in estimating Y. The coefficient b₀ is the estimated constant, and b₁, b₂ ..., b_n are called the regression coefficients and represent the variation of the predicted score (Kadir Cavdar, 2014).

In this statistical procedure, standardized coefficient indicates the relative predictive power of individual parameters. The dependent variable is the anthropometric parameter on passenger human body which should be normally distributed. In general, stature and weight of people are basically known. Depending on stature and weight, other passenger's anthropometric parameters like body surface area can be estimated inside the interior bus. Multiple regression analysis was done using normally distributed parameters, where the dependent variable "Y" is the anthropometric characteristic on human body.

The multiple stepwise regressions were applied for this study. The multiple regressions were used for obtaining the significant parameter which mostly influences anthropometric parameter. By analyzing the Addis Ababa anthropometric dimension population using the calculated 5th, 75th, and 95th percentage, we can estimate passenger comfort statistical prediction model using the range of seat and stand adjustability.

❖ Research Approach

- To compare the total car weight of current LRT Vehicles found using an assumed average Addis Ababa passenger weight with a random selection of passenger weight.
- Is there a significant difference between an assumed 60 kg per person and a scenario with randomly generated weights and other consideration?
- Should we continue to design with this type of assumption? Or change the approach?

4.2 Assumption for sample size

- Male Passenger weight- 55-70kg.
- Male Passenger height.1.52cm-1.70cm.
- Female Passenger weight-45-65kg.
- Female Passenger height.1.45cm-1.75cm.

The Addis Ababa passengers body surface area, $BSA=0.007184*wt^{0.425}* Ht^{0.725}$, where,

Wt. =passenger body weight and Ht. = passenger height.

Using engineering standard anthropometric formula we can calculate the body surface area for each individual passenger using randomly selected variables. Addis Ababa average passenger weight specification is used by Ethiopian railway corporations. Before prediction the model, we should have to know whether the variables of correlations have a positive, negative or none correlation. The prediction models should be made based on the correlation of the anthropometric and corresponding variables to be considered. For the prediction model the weight and statures are mostly known in all over the world's country population.in this study , the passengers body surface area are being calculated using the above engineering anthropometric formula.

Table 4.1 Addis Ababa passengers body surface area interpretation.

	HT(cm)	WT(kg)	BSA (body surface area)
Male Passengers	1.52	55	1.51m ²
	1.54	56	1.53 m ²
	1.56	57	1.56 m ²
	1.58	58	1.58 m ²
	1.60	59	1.61 m ²
	1.62	60	1.64 m ²
	1.64	61	1.66 m ²
	1.66	62	1.69 m ²
	1.68	63	1.71 m ²
	1.70	64	1.74 m ²
Female passengers	1.43	45	1.32 m ²
	1.45	47	1.36 m ²
	1.47	49	1.39 m ²
	1.49	51	1.44 m ²
	1.51	52	1.47 m ²
	1.53	53	1.49 m ²
	1.55	54	1.52 m ²
	1.57	56	1.55 m ²
	1.59	68	1.70 m ²
	1.61	70	1.74 m ²

The Addis Ababa passengers body surface area (BSA) = $0.007184 * wt^{0.425} * Ht^{0.725}$,

$$BSA = 0.007184 * wt^{0.425} * Ht^{0.725} = 0.007184 * 55^{0.425} * 152^{0.725} = 1.51m^2$$

$$BSA = 0.007184 * wt^{0.425} * Ht^{0.725} = 0.007184 * 56^{0.425} * 154^{0.725} = 1.53m^2$$

$$BSA = 0.007184 * wt^{0.425} * Ht^{0.725} = 0.007184 * 57^{0.425} * 156^{0.725} = 1.53m^2$$

Anthropometrics design should be used in predicting passenger capacity which is based on human factors to be considered when designing the given system, such as passengers holding items like laptops, small luggage's and mini items where their weighting factors have significant factors on passenger settlement inside the rail vehicles car.

The rail industry currently uses the AW0-4 rating scale to design cars that withstand passenger loading.

- AW0: total car weight with no passengers in a revenue service ready condition.

- AW1: AW0 + full seated passenger load.
- AW2: AW1 + Standing passenger load of 4 people per m².
- AW3: AW1 + Standing passenger load of 6 people per m².
- AW4: AW1 + Standing passenger load of 8 people per m²

Table 4.2 Descriptive Statistics

	Mean	Std. Deviation	N
passenger body surface area in meter square	1.5605	.12609	20
passenger height in meter	1.5650	.07487	20

Correlations Table

		passenger body surface area in meter square	passenger height in meter
passenger body surface area in meter square	Pearson Correlation	1	.953**
	Sig. (2-tailed)		.000
	N	20	20
passenger height in meter	Pearson Correlation	.953**	1
	Sig. (2-tailed)	.000	
	N	20	20

** . Correlation is significant at the 0.01 level (2-tailed).

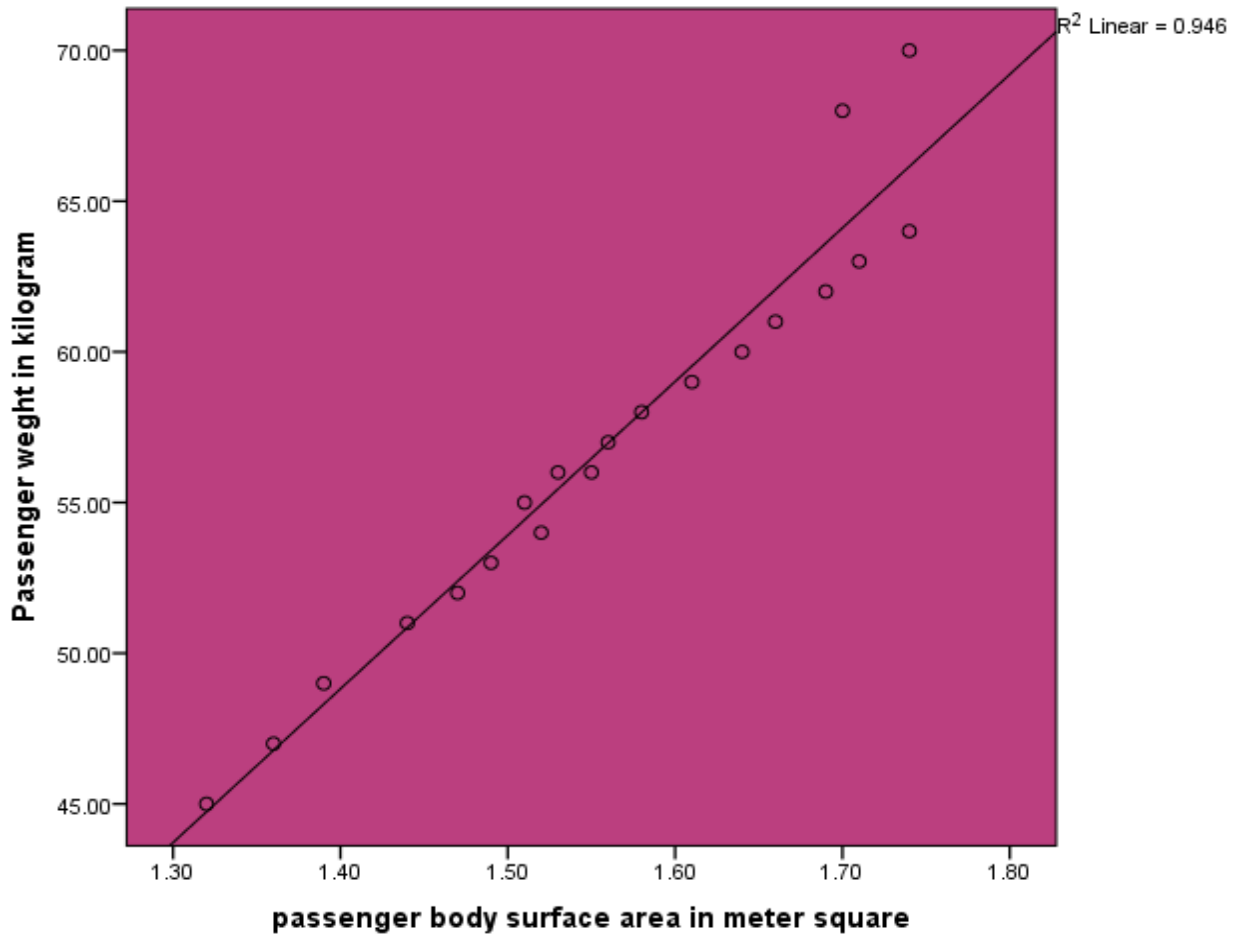

Figure 3.7 A scatter plots of passenger’s body surface area and weight.

As we can see from the above SPSS output, the two variables have a strong positive relation each other since Pearson correlation with $R^2 = 0.953$ is approximately equals to one. Therefore we can predict the passenger seat and stand capacity using selected scenarios and passengers anthropometric variables.

The body surface area is calculated using randomly selected height and body weight for comparison to that of railway passenger standing and seat scenario specification which is important to predict a multiple linear regression and Anova (analysis of variance) using statistical interpretation of correlation coefficients by SPSS software package.

4.3 SPSS Output Model Summary

Table 4.3 Model Summary

Model	R	R Square	Adjusted R Square	Std. Error of the Estimate
1	.684 ^a	.468	.405	.39554

a. Predictors: (Constant), passenger body surface area in meter square, Passenger weight in kilogram

Coefficients

Model	Unstandardized Coefficients		Standardized Coefficients	T	Sig.
	B	Std. Error	Beta		
(Constant)	8.170	1.743		4.687	.000
1 Passenger weight in kilogram	.153	.059	1.967	2.587	.019
passenger body surface area in meter square	-9.850	3.092	-2.421	3.185	.005

a. Dependent Variable: Number of passenger

ANOVA

Model	Sum of Squares	Df	Mean Square	F	Sig.
1 Regression	2.340	2	1.170	7.479	.005 ^b
Residual	2.660	17	.156		
Total	5.000	19			

a. Dependent Variable: Number of passenger

b. Predictors: (Constant), passenger body surface area in meter square, Passenger weight in kilogram

$$Y=8.170+0.153(\text{passenger weight})-9.850(\text{passenger body surface Area})$$

The above equation is a multivariate multiple regression and prediction model equations. The assumptions are based on the correlation coefficient. A bivariate Pearson Correlation is denoted

as R, and may also be known as Pearson's r value which is 0.684 as shown in the table 4.3 that indicates a strong correlation.

Table 4.4 LRT specification on weights of vehicles and passengers.

Loads	Car body weight	Passenger weight	Total weight
Empty vehicle (t)	44	0	44
Seating capacity (t)	44	15.24	59.24
Overload capacity (t)	44	19.02	63.02
Axle load	$\leq 11 (1+3\%) \text{ t}$		

Table 4.5 Seating capacity of vehicles used by Addis Ababa LRT specification.

Number of passengers (persons)	Seated	Standing	Total
Seats (AW₁)	65	0	65
Seating capacity (AW₂) (standing:6 persons/m²)	65	189	254
Overload capacity (AW₃) (standing:8 persons/m²)	65	252	317

Table 4.6 Number of passengers and weight used by Addis Ababa LRT specification.

Condition	Number of passengers	Approximate car body weight (t)	Passenger weight (t)	Total (t)
AW1	64	44	3.84	47.84
AW2	254	44	15.24	59.24
AW3	317	44	19.02	63.02

Note: Take 60 kg as average weight of each passenger; tare weight of vehicles $\leq 44t$.

➤ **Weight capacity inside Aw1**

- ❖ Seating Capacity of 65
- ❖ Standing capacity 0
- ❖ Car body Weight 143000kg
- ❖ Passenger weight 3840kg

➤ **Weight Capacity inside Aw2**

- ❖ Seating Capacity of 65
- ❖ Standing capacity 189
- ❖ Car body Weight 143000kg
- ❖ Passengers weight 15240kg

➤ **Weight capacity inside Aw3**

- ❖ Seating Capacity of 65
- ❖ Standing capacity 252
- ❖ Car body Weight 143000kg
- ❖ Passengers weight 19020kg

Case 1 Hypothetical Train Car (Aw1)

- ❖ Seating Capacity of 65
- ❖ Predicted passenger Space 60m²
- ❖ Car body Weight 143000kg

Using the predicted multiple linear regression model equation, we can estimate the body surface area of the target population inside the rail vehicles.

$$65\text{Passengers} = 8.170 + 0.153(3840) - 9.850(\text{BSA})$$

$$\text{Total BSA} = 60\text{m}^2$$

$$\text{The Predicted passenger Space (BSA)} = 60\text{m}^2$$

In order to predict the maximum car body weight including the passenger weights. Therefore the predicted total average weight of the passengers (body mass index) = $3840\text{kg}/60\text{m}^2 = 64\text{kg}/\text{m}^2$.

$$\text{Aw1} = 3840\text{kg} \times \{65 + 64\text{kg}/\text{m}^2 \times 60\text{m}^2\} + 143,000\text{kg} = 15138.2 \text{ tone.}$$

Case 2 Hypothetical Train Car (Aw2)

- ❖ Seating Capacity of 65
- ❖ Predicted Standing Space 211m^2
- ❖ Car body Weight 143000kg

$$254 \text{ passengers} = 8.170 + 0.153(15240 \text{ kg}) - 9.850(\text{BSA})$$

Passenger (BSA) = 211.8m^2 , Therefore, the average body mass index of target passengers,

$$\text{BSA} = 15240/211.8\text{m}^2 = 72\text{kg}/\text{m}^2$$

$$\text{Aw2} = 15240\text{kg} \times \{65 + 72\text{kg of pass}/\text{m}^2 \times 211\text{m}^2\} + 143,000\text{kg} = 231669.1\text{tone.}$$

This shows that Aw2 increased by 216530.9 tone .

Case 3 Hypothetical Train Car (Aw3)

- ❖ Seating Capacity of 65
- ❖ Predicted passenger Space 264m^2
- ❖ Car body Weight 143000kg

$$317\text{passengers} = 8.170 + 0.153(19020 \text{ kg}) - 9.850(\text{BSA})$$

Passenger (BSA) = 264.1m^2 , so the total passenger Space = 264.1m^2 .

Therefore, the average body mass index of target passengers,

$$(\text{BMI}) = 19020/264.1\text{m}^2 = 72\text{kg}/\text{m}^2.$$

$$\text{Aw3} = 19020\text{kg} \times \{65 + 72\text{kg of pass}/\text{m}^2 \times 264\text{m}^2\} + 143,000\text{kg} = 362911.5\text{tone.}$$

This shows that Aw3 increases by 131242.4 tone as compared to Aw3 weight and also increased by 347773.3 tones.

Using LRT specification scenarios.

$Aw3 = 19020kg \times \{65+60kg \text{ pass}/m^2 \times 264m^2\} + 143,000kg = 302656.1 \text{tone.}$

Using AW3 assumptions, we would see 72kg/m², approximately 60255.4tonsgreater than as compared to what would “typically” be seen in LRT specification.

4.4 Mathematical Prediction Model of passenger standing

As we can see from SPSS output result, in table 4.3, the statistically predicted model should be used, by estimating the amount of body surface area inside train space Aw1, Aw2 and Aw3 compartment in order to settle the passenger’s capacity in each rail vehicles coach using Addis Ababa population anthropometric human size and also body surface area using the following formula as shown below,

$$Y=8.170+0.153(\text{passenger weight})-9.850(\text{passenger body surface Area})\dots\dots\dots 4.1$$

4.4.1 Assumption on Prediction Model of passenger standing

- The dependent variable and the residuals (the distance of the cases from the line of best fit) is approximately normally distributed.
- Normality test Hypotheses
 - H0; the observed distribution fits the normal distribution.
 - Ha; the observed distribution does not fit the normal distribution.
- If we accept the H₀, we accept/assume normality.
- Passenger weight- 45-74kg.
- Passenger capacity (using gender).
- Passenger Stature.151cm-180cm.
- Passenger age, 15-45.
- Passenger shoulder breadth.42cm-71cm.
- Passenger hip breadth 72-101cm.
- Passenger sitting to shoulder height.50cm-79cm.

-
- Passenger knee height.40cm-74cm.
 - Passenger waist to knee height.40cm-74cm.
 - Calculated Passenger body surface area.1.43-1.89m².
 - Calculated Passenger body mass index. 34.9-36.7.

The Addis Ababa passengers body surface area have been estimated using standardized Anthropometric human size formula where, the coefficients are being suitable for standard units Of variables, the more significant the coefficients between the two independent variables the better the prediction made by the regression equation. Therefore in the above equation, y is indicating the number of passenger capacity inside the rail vehicle which may change depending on human factors like body surface area, height and weight capacity. Similarly the dependent variables could be predicted using independent variables by keeping the statistical linear regression assumption as shown above and the model summary is shown below in the following table 4.7.

Table 4.7 Equations on the estimation of the anthropometric parameters on passenger body.

Parameters to be predicted (y)	Prediction Model equations	R ²	Sig. of Coeffi.	Stand. Error of estimate
Passenger body mass index (BMI)	1. $BMI = 13.831(\text{Hip Breadth}) + -0.275 (\text{ Passengers Capacity }) - 0.14$.947	all<0.05	0.2963
	2. $BMI = -0.259(\text{Passengers Capacity}) + 6.182 (\text{BSA})+8.560$.947	all<0.05	0.2968
	3. $BMI = -0.275(\text{passengers Capacity}) + 13.831 (\text{Shoulder Breadth})+11.582$.947	all<0.05	0.2964
Passengers capacity	4. $\text{pass.cap} = -0.694(\text{ BMI }) + 10.125 (\text{ Shoulder Breadth }) + 8.960$.201	all<0.05	0.4712
	5. $\text{Pass. Cap} = -0.667(\text{ BMI}) + 4.350 (\text{BSA}) + 6.560$.182	all<0.05	0.4767
	6. $\text{Pass. Cap} = -0.694(\text{ BMI}) + 10.125 (\text{Stature}) - 2.076$	0.201	all<0.05	0.4712

4.5 Result and Discussion

As it is shown in the normality table, the results shows two well-known tests of normality, namely the Kolmogorov-Smirnov Test and the Shapiro-Wilk Test. The Shapiro-Wilk Test is more appropriate for small sample sizes (< 50 samples), but can also handle sample sizes as large as 2000. For this reason, the researcher has used the Shapiro-Wilk test for the prediction model results as a numerical means of assessing normality.

In the predicted models of passenger body mass index, the data is normal Since **Sig.** value of the Shapiro-Wilk Test is greater than 0.05, But in the Passenger capacity predicting model, the normality test has shown a **Sig.** value below 0.05 in both model four and six, which clearly indicates the data is significantly deviate from a normal distribution.

The anthropometric parameters in this study represent the Addis Ababa population inside the rail vehicles. Passenger capacity and passenger body mass index have relationship with stature, shoulder breadth, hip breadth but not with seating height, sitting to shoulder heights and passenger weights.

As we can see in table 4.7, the coefficients of all significance value has shown less than the statistical significance level of 0.05 in all prediction models.

Form the above results, to decrease some of the design difficulties in predicting passenger space, more anthropometric variables should be used inside interior bus design, and Mean anthropometric measurement should also be collected from recent journal of Ethiopian health sciences. By doing so, designers should gain more data of Addis Ababa passengers of human measurement that should be taken according to specific standards. In spite of such limitations, this study demonstrated the usefulness of the estimation of anthropometric parameters.

The anthropometric formulation of prediction model that is extracted from this study can be used by local automotive industry in Ethiopia to produce better rail passenger seat and oriented products for Addis Ababa light rail vehicle passengers.

In multiple linear regression model, graphical interpretation has the advantage of allowing good judgement to assess normality in situations when numerical tests might be over or under sensitive, but graphical methods do lack objectivity.

In order to determine normality graphically, we can use the output of a normal Q-Q Plot. If the data are normally distributed, the data points will be close to the diagonal line. If the data points stray from the line in a non-linear fashion, the data are not normally distributed. When the data fits the normal Q-Q plot line, the data is normally distributed. It is possible to correctly interpret the graph, rely on the numerical methods because it can take a fair bit of experience to correctly judge the normality of data based on plots. “**Test of Normality**” box gives the K-S and S-W test results. If the test is not significant, then the data are normal, so any value above .05 indicates normality. If the test is significant (less than .05), then the data are non-normal. We can also interpret the normality using skewness and kurtosis values to determine normality, using descriptive table instead of Shapiro-Wilk test, where **Z-value** should be between -1.96 and 1.96 in SPSS output.

Generally, the overall notion of this study is not to give a detailed prescription for all factors of passenger discomfort inside the rail vehicle. As per the scope and result of the research analysis, it is possible to make certain recommendation in order to optimize passenger discomfort, passenger congestion and passenger space allocation using the predicted models.

4.6 Major Findings

The major finding in this study paper is that the statistical test was analyzed between passenger discomforts and corresponding related parameters. The mismatch is being observed, as investigated by the t-test between the anthropometric dimensions of the target population and the seat dimensions.

- Based on statistical mean and standard deviation, passengers mismatch has been observed in some parameters, which are, between hip breadth and seat width, shoulder breadth and backrest width, between knee height and seat height.
- As per the analysis of goodness of fit between the passengers of anthropometric percentages and the train vehicles seats, a passenger mismatch has been observed in only male's shoulder breadth and vehicles backrest width.
- All The data's of independent variables that are being used to predict Passenger body mass index(dependent variables) are a good fit in predicting passenger comfort and space allocation inside the new rail vehicles since it fulfills all the assumptions of the models.
- Passenger body mass index has been found as a better predicting variable instead of passenger capacity in predicting better passenger comfort and space allocations.

CHAPTER FIVE

CONCLUSION AND RECOMMENDATION AND FUTURE RESEARCH DIRECTION

5.1 Conclusions

As per the analysis of goodness of fit between the passengers anthropometric variables, percentages with that of corresponding train vehicles seats parameters, a passenger mismatch has been proved using T-test in only male's passenger seat parameters inside the rail vehicle seat as compared to female passengers.

The statistical model equations for the passenger body mass index and passenger capacity had been developed for predicting in investigating for Addis Ababa passengers discomfort in rail vehicles. The independent variables data were collected from Addis Ababa adult clothing dimensions and from journals of Anthropometric variables of Addis Ababa populations. The significant explanatory independent variables used to predict the passenger body mass were passenger capacity, body surface area, shoulder breadth and hip breadth. The other significant explanatory independent variables used to predict the passenger capacity were, body mass index, body surface area, stature, and shoulder breadth. The multiple regression model of passenger body mass was compared to regression model of passenger capacity using validation data and model summaries to show how well the model predicts the passengers discomfort; consequently, It is proved that the passenger body mass index model best predicts passenger allocation in all independent variables groups than the passenger capacity models.

5.2 Recommendations

Based on the scope of research analysis, the following recommendations are forwarded as the result of the study:

- Although in using the suggested formula any increase in weight or size of passenger should be accounted for and the data's should also be revisited to determine the seated passenger weight.
- As an organizations and corporation, ERC should consider designing for not only today's population but tomorrow's as well.
- The prediction model equations could be used to predict for different populations specifically for passengers using the east-west and south- north transit in Addis Ababa Light Rail Transits; hence, the future passenger volume might also be managed for future passenger's space planning inside the rail vehicles.

5.3 Future Research Direction

As this research was concentrating passenger weight allocation, more on the seat dimensions, there was not much focusing on other factors for ride comfort. Therefore, in the future, it is suggested that other interested investigators may conduct more studies on other factors of passenger discomfort like Pressure and stress in passenger standing and seat of interior rail bus design. Other researcher should also consider sufficient anthropometric variables like body anatomical size in order to optimize passenger congestion and allocation since more data is helpful for designing suitable passenger seat and standing capacity by taking factors into consideration on passenger discomfort parameters in both passenger standing and seat of interior rail bus design using internal and external passenger factors like Passenger income, Sex, education level and occupation.

BIBLIOGRAPHY

1. D. Van de Velde, **Long distance bus services in Europe: concession or free market**, Discussion paper no. 2009-21, Joint Transport Research Centre, 2009.
2. Abel Tesfaye, **Anthropometric data of Addis Ababa Adult people for clothing design**, School of Mechanical and industrial University of Addis Ababa, 2014.
3. Saba G/Gergs G/Yesus, Ajit Pal Singh, Guteta Kabeta Woyessa & Solomon Seid,2013, **Global Journal of Researches in Engineering Industrial Engineering**, Volume 13 Issue 1 Version 1.0,Global Journals Inc. (USA), 975-5861.
4. Tilahun Meshesha Fenta, **Demands for Urban Public Transportation in Addis Ababa**, Journal of Intelligent Transportation and Urban Planning, Jul. 2014, Vol. 2 Iss. 3, PP. 121-128.
5. Md.Ariful Islam, Md.Asadujjaman, **Ergonomics consideration for hospital bed design:** Journal of Modern Science and Technology Vol. 1. May 2013, Pp.30-44.
6. Bridger, R.S. (1995). **Introduction to Ergonomics**. New York: McGraw-Hill.
7. Martin Freer, Loughborough University, Anthropometric study to update minimum aircraft seating standards, July 2001
8. Kasu Jilcha, **“Ergonomics and management style implementation,”** February 2015.
9. Metin Tunay and Kennan Melemez, **An analysis of biomechanical and anthropometric parameters on classroom furniture design**, African Journal of Biotechnology Vol.7 (8), pp. 1081-1086, 17 April, 2008.
10. Dr.Mohammed Rajik Khan, **Re-design of drivers’ Car Seat Using three dimensional Reverse Engineering**, National Institute of Technology Rourkela, 2010-2014.
11. Kadir CAVDAR, **Determination of the Some Anthropometric Data of Turkish Men Population**, Gazi University Journal of Science, 801-807 (2014).
12. Pachling and Vishwanath.K. , Prof. Chaitanya S. V., **Review of design aspects of major components of automotive Seat**, Journal of Engineering and Technology Innovation, (Asia), 2013, 33-38.
13. Maruf khondker, **Ergonomic design seating model, position of Passenger car**, university of Concordia, Human Factors Engineering, Nov 2009.

-
14. Professor James D.Mc.Glothlin, **Occupational Engineering anthropometric, university of Purdue**, www.utube.com.
 15. Perali, L., **Ergonomics of Car Seat**, www.katedra.it/English/Publications/Carseat Syed
 16. Asif, Qutubuddin S, Hebbal S, **Anthropometric analysis of classroom furniture used in Colleges**, International Journal of Engineering Research and Development, Volume 3, PP. 01-07, (September 2012).
 17. Pachling Vishwanath K, **Asian Journal of Engineering and Technology Innovation**, Nov 11, 2013.
 18. Philadelphia .PA, **Changes in rider Anthropometrics & the effects on rail Car Design**, APTA Rail Conference, June 4, 2013.
 19. Ethiopian Railways Corporation, **bankable feasibility study for Addis Ababa Light Rail Transit (AA LRT) Project**, Volume IV, July16, 2009.
 20. Hand book of China Railway Group, **South-north Line and East-west Line (Phase I) Light Rail Project of Addis Ababa, Ethiopia**, July 2013.
 21. Laura Elizabeth Map, HIS, **Clothing size Dissatisfaction, a stronger predictor of weight related avoidance than body mass index**, May 2011.

APPENDIX: SPSS DATA OUTPUT

Part I, SPSS Output of Multiple Regression model

Model Summary

Model	R	R Square	Adjusted R Square	Std. Error of the Estimate
1	.973 ^a	.947	.943	.29639

a. Predictors: (Constant), Passenger's Capacity, hip breadth circumference in meter

b. Dependent Variable: Passenger body mass index

ANOVA^a

Model		Sum of Squares	Df	Mean Square	F	Sig.
1	Regression	42.460	2	21.230	241.676	.000 ^b
	Residual	2.372	27	.088		
	Total	44.832	29			

a. Dependent Variable: Passenger body mass index

b. Predictors: (Constant), Passenger's Capacity, hip breadth circumference in meter

Coefficients

Model		Unstandardized Coefficients		Standardized Coefficients	T	Sig.
		B	Std. Error	Beta		
1	(Constant)	7.433	.553		13.439	.000
	hip breadth circumference in meter	13.831	.629	.979	21.985	.000
	Passenger's Capacity	-.275	.109	-.112	-2.523	.018

a. Dependent Variable: Passenger body mass index

Explore

Descriptive

		Statistic	Std. Error
Standardized Residual	Mean	0E-7	.17616607
	95% Confidence Interval Lower Bound for Mean	-.3603001	
	Upper Bound	.3603001	
	5% Trimmed Mean	.0005467	
	Median	.0595564	
	Variance	.931	
	Std. Deviation	.96490128	
	Minimum	-1.70270	
	Maximum	1.71558	
	Range	3.41828	
	Interquartile Range	1.67899	
	Skewness	-.025	.427
	Kurtosis	-.868	.833

Tests of Normality

	Kolmogorov-Smirnov ^a			Shapiro-Wilk		
	Statistic	df	Sig.	Statistic	Df	Sig.
Standardized Residual	.087	30	.200*	.971	30	.567

Standardized Residual

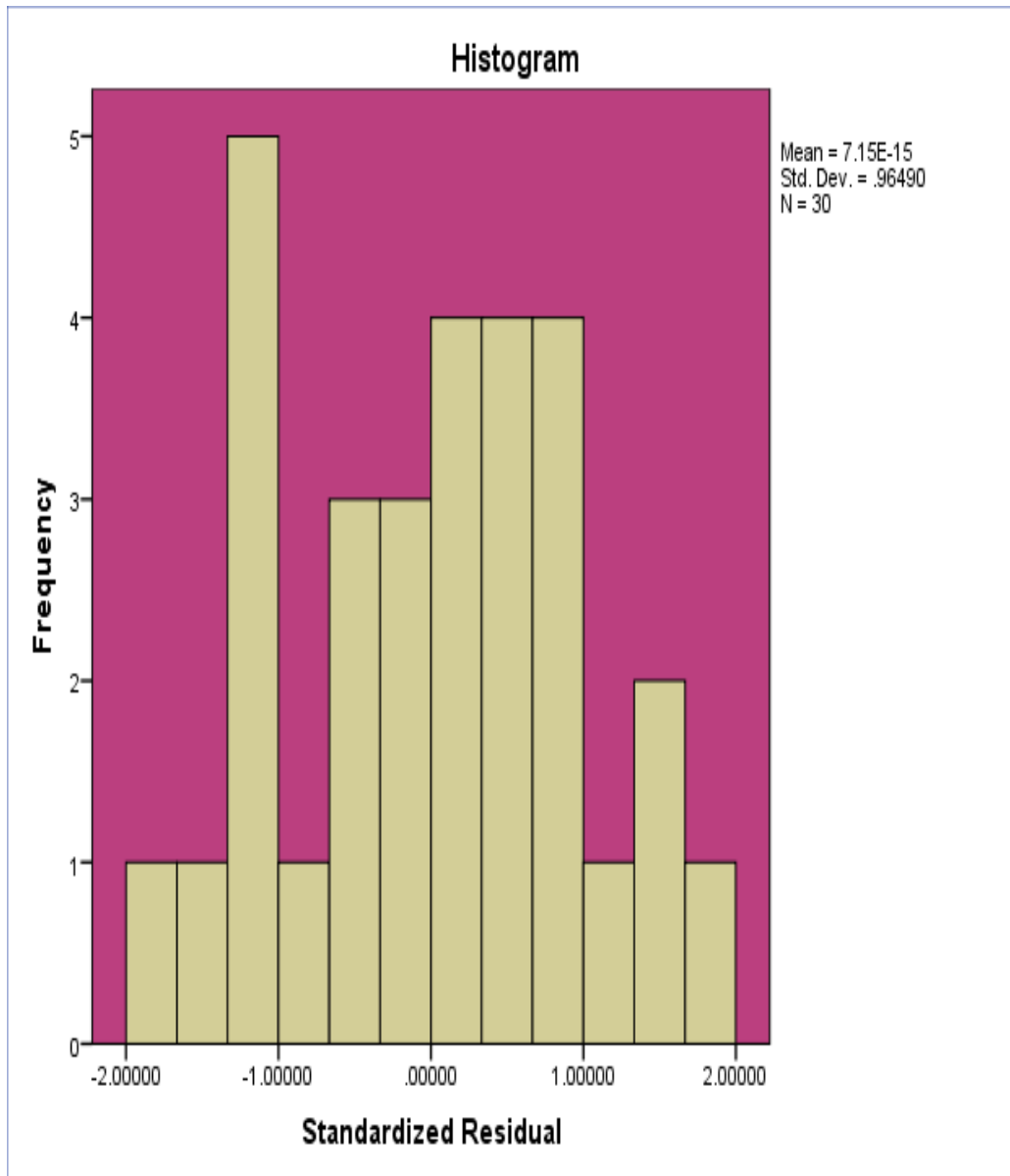

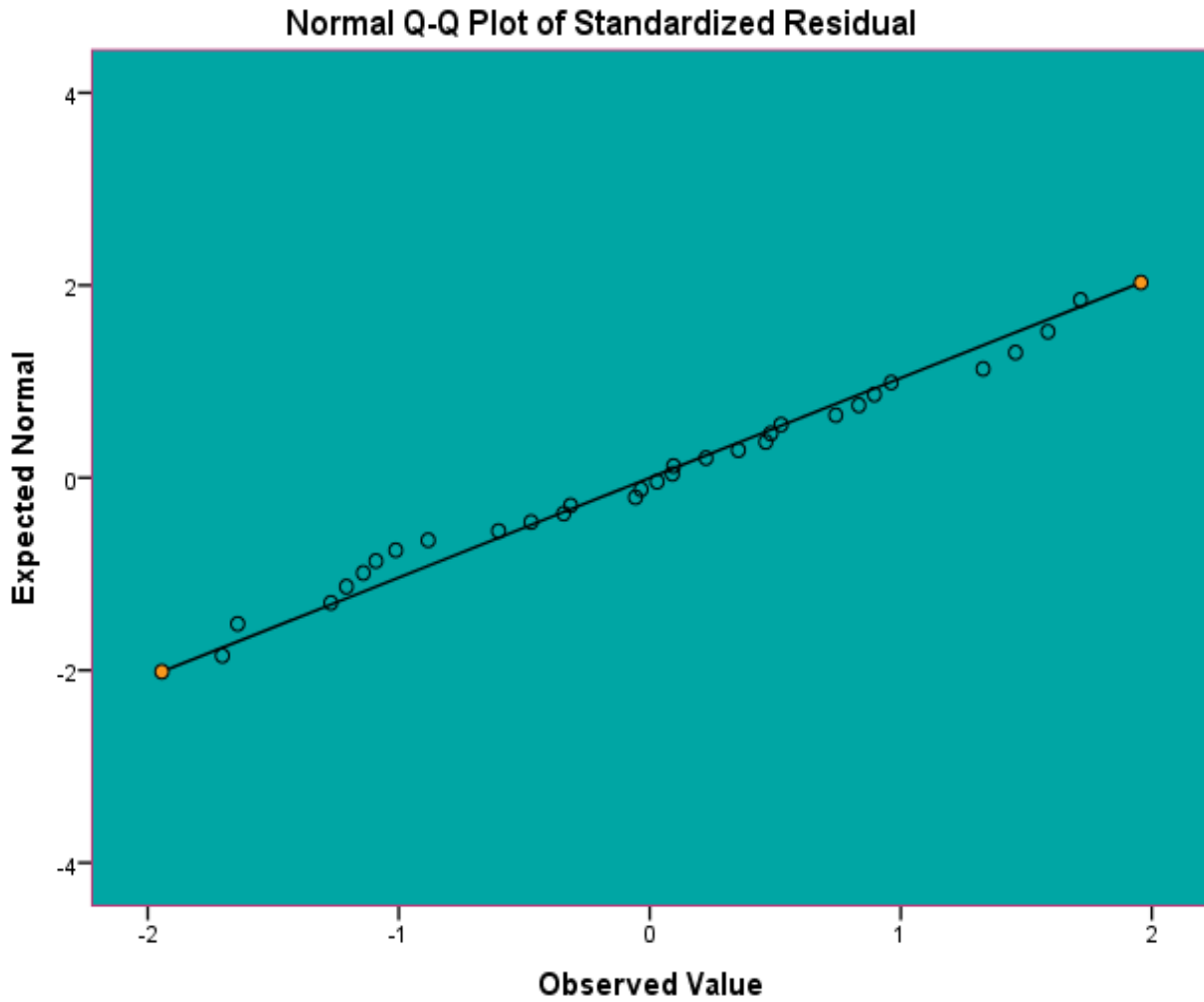

Model 2

Model Summary

Model	R	R Square	Adjusted R Square	Std. Error of the Estimate
1	.973 ^a	.947	.943	.29686

a. Predictors: (Constant), body surface area in meter square, Passenger's Capacity

b. Dependent Variable: Passenger body mass index.

ANOVA^a

Model	Sum of Squares	Df	Mean Square	F	Sig.
1 Regression	42.452	2	21.226	240.867	.000 ^b
Residual	2.379	27	.088		
Total	44.832	29			

a. Dependent Variable: Passenger body mass index

b. Predictors: (Constant), body surface area in meter square, Passenger's Capacity

Coefficients

Model	Unstandardized Coefficients		Standardized Coefficients	T	Sig.
	B	Std. Error	Beta		
1 (Constant)	8.560	.505		16.937	.000
Passenger's Capacity	-.259	.109	-.106	-2.374	.025
body surface area in meter square	6.182	.282	.979	21.948	.000

a. Dependent Variable: Passenger body mass index

**Explore
Descriptives**

		Statistic	Std. Error
	Mean	0E-7	.17616607
	95% Confidence Interval Lower Bound for Mean	-.3603001	
	Upper Bound	.3603001	
	5% Trimmed Mean	.0142114	
	Median	.1997243	
	Variance	.931	
Standardized Residual	Std. Deviation	.96490128	
	Minimum	-1.79997	
	Maximum	1.53540	
	Range	3.33537	
	Interquartile Range	1.52442	
	Skewness	-.220	.427
	Kurtosis	-.959	.833

Tests of Normality

	Kolmogorov-Smirnov ^a			Shapiro-Wilk		
	Statistic	df	Sig.	Statistic	df	Sig.
Standardized Residual	.109	30	.200*	.960	30	.313

*. This is a lower bound of the true significance.

a. Lilliefors Significance Correction.

Standardized Residual

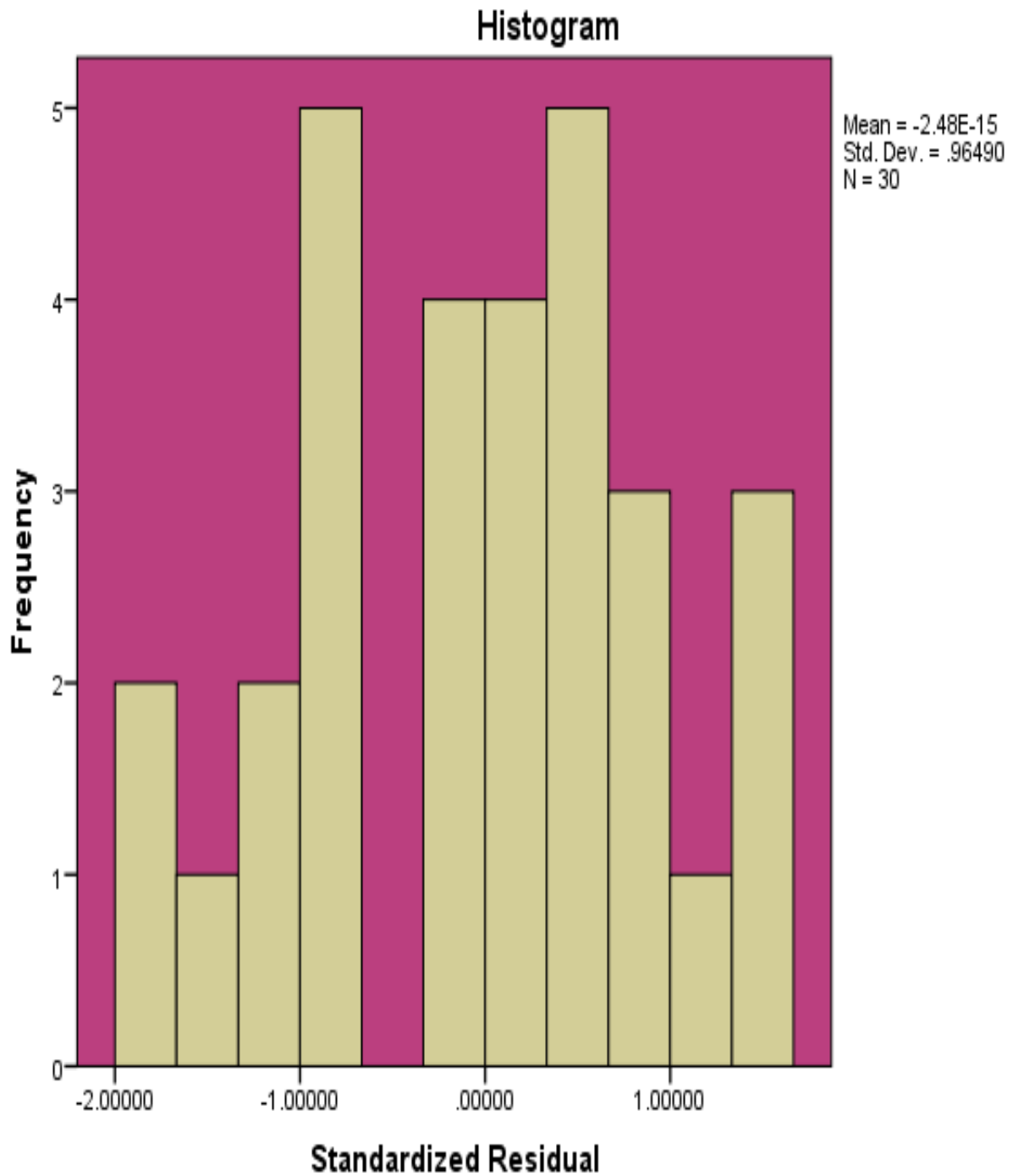

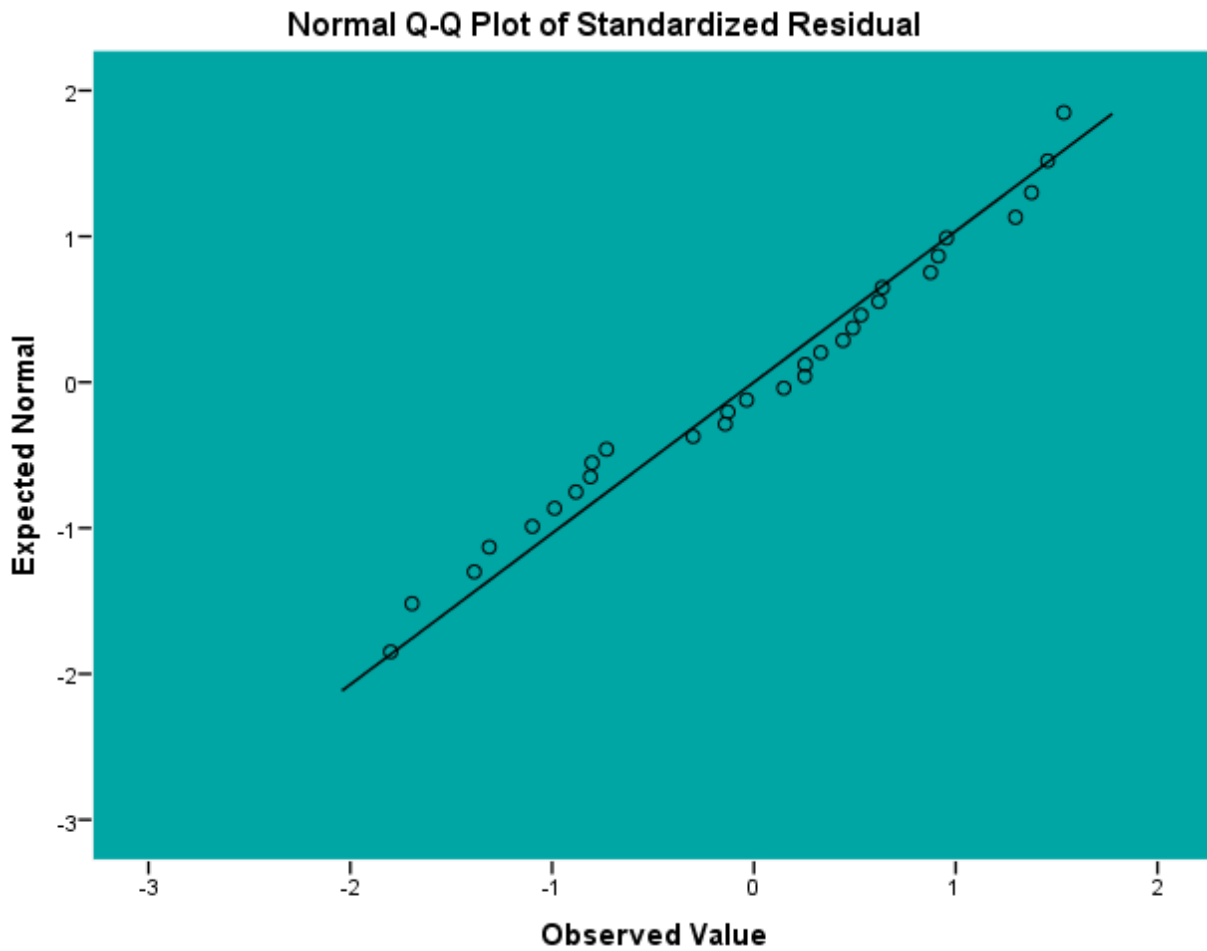

Model 3

Model Summary

Model	R	R Square	Adjusted R Square	Std. Error of the Estimate
1	.973 ^a	.947	.943	.29639

a. Predictors: (Constant), shoulder breadth in meter, Passenger's Capacity

b. Dependent Variable: Passenger body mass index

ANOVA^a

Model	Sum of Squares	Df	Mean Square	F	Sig.
1 Regression	42.460	2	21.230	241.676	.000 ^b
Residual	2.372	27	.088		
Total	44.832	29			

a. Dependent Variable: Passenger body mass index

b. Predictors: (Constant), shoulder breadth in meter, Passenger's Capacity

Coefficients

Model		Unstandardized Coefficients		Standardized Coefficients	T	Sig.
		B	Std. Error	Beta		
1	(Constant)	11.582	.378		30.630	.000
	Passenger's Capacity	-.275	.109	-.112	-2.523	.018
	shoulder breadth in meter	13.831	.629	.979	21.985	.000

a. Dependent Variable: Passenger body mass index

Explore

Descriptives

		Statistic	Std. Error
Standardized Residual	Mean	0E-7	.17616607
	95% Confidence Interval Lower Bound for Mean	-.3603001	
	Upper Bound	.3603001	
	5% Trimmed Mean	.0005467	
	Median	.0595564	
	Variance	.931	
	Std. Deviation	.96490128	
	Minimum	-1.70270	
	Maximum	1.71558	
	Range	3.41828	
	Interquartile Range	1.67899	
	Skewness	-.025	.427
	Kurtosis	-.868	.833

Tests of Normality

	Kolmogorov-Smirnov ^a			Shapiro-Wilk		
	Statistic	df	Sig.	Statistic	df	Sig.
Standardized Residual	.087	30	.200*	.971	30	.567

*. This is a lower bound of the true significance.

a. Lilliefors Significance Correction

Standardized Residual

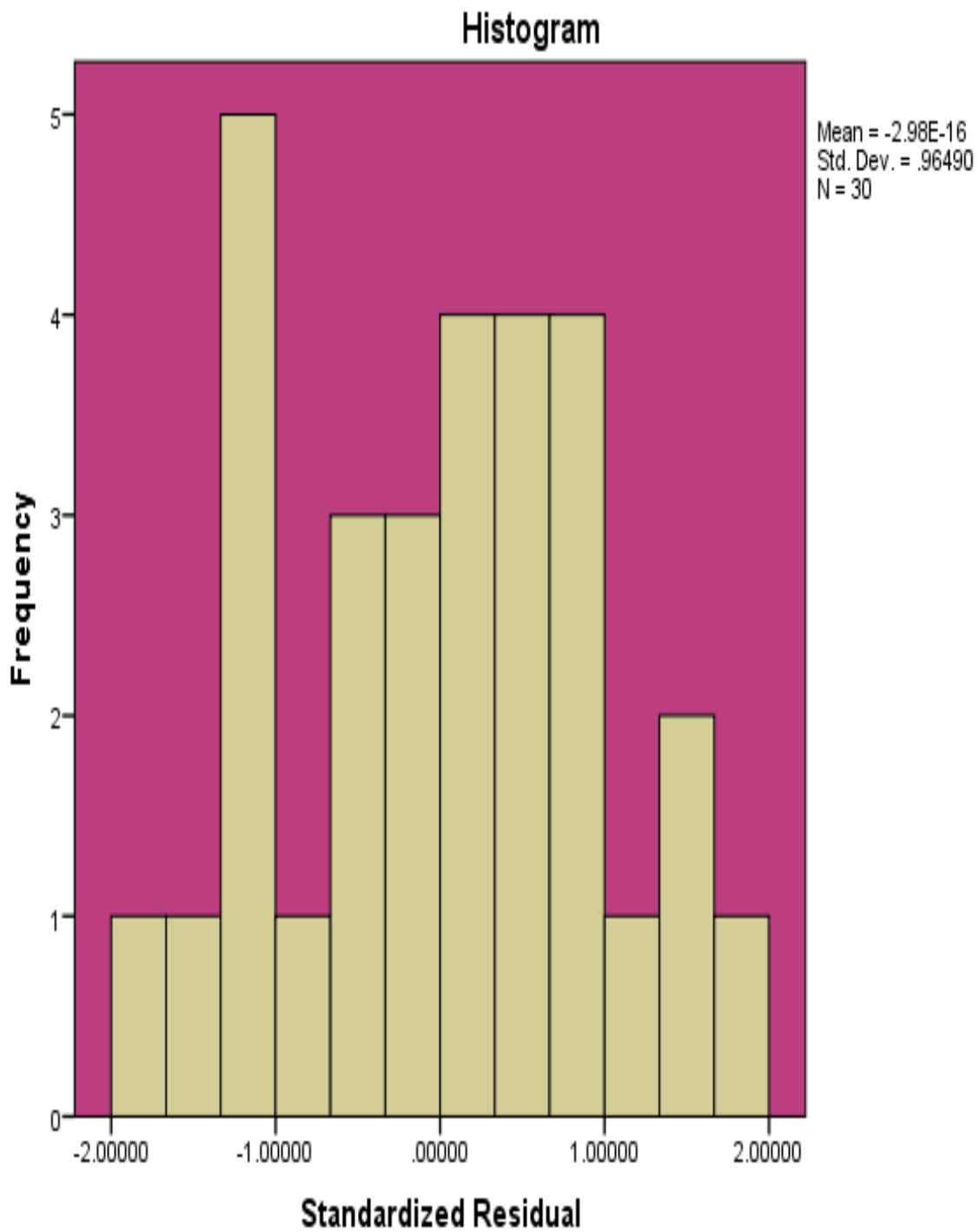

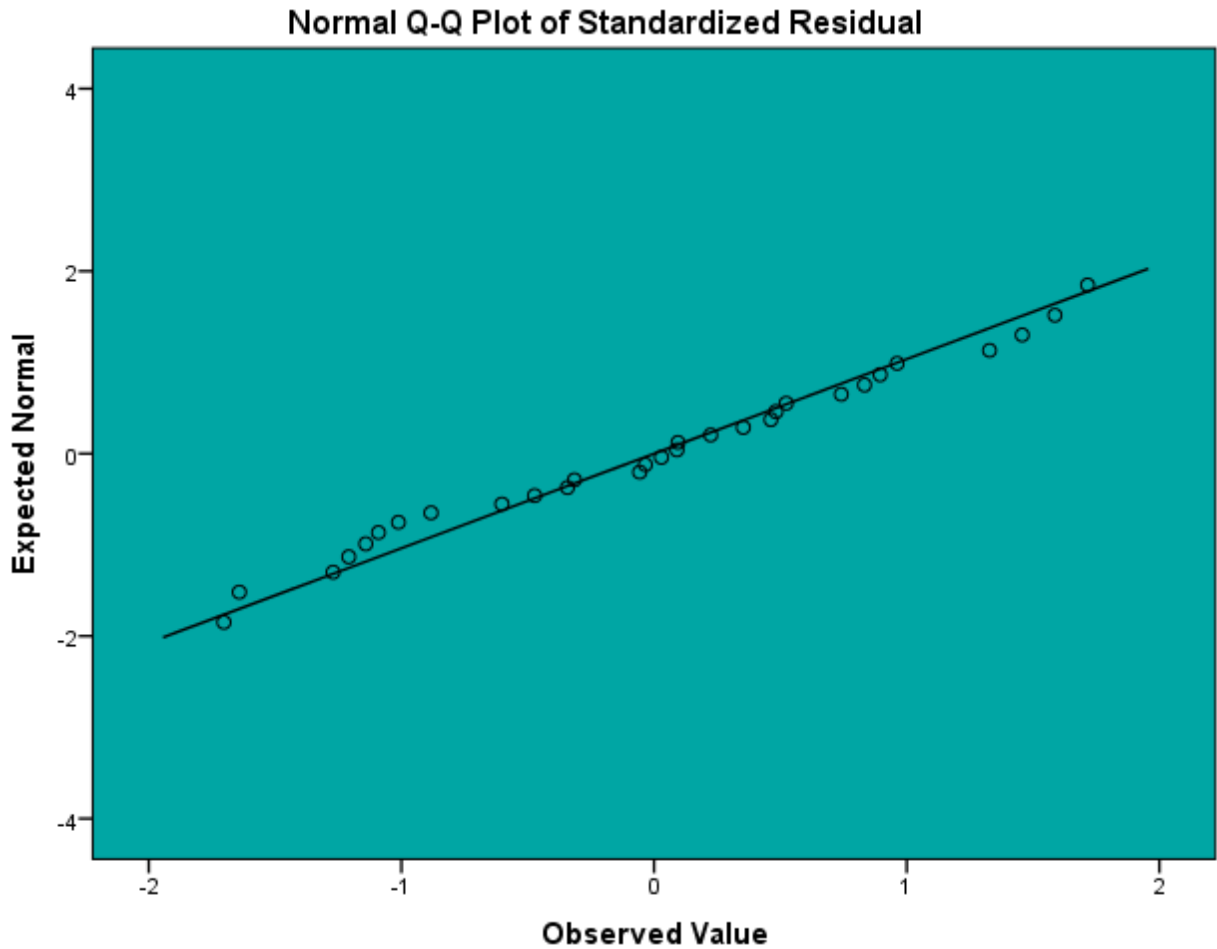

Part II, SPSS Output of Multiple Regression model

Model 4

Model Summary

Model	R	R Square	Adjusted R Square	Std. Error of the Estimate
1	.448 ^a	.201	.142	.47116

a. Predictors: (Constant), shoulder breadth in meter, Passenger body mass index

b. Dependent Variable: Passenger's Capacity

ANOVA^a

Model		Sum of Squares	Df	Mean Square	F	Sig.
1	Regression	1.506	2	.753	3.393	.048 ^b
	Residual	5.994	27	.222		
	Total	7.500	29			

a. Dependent Variable: Passenger's Capacity

b. Predictors: (Constant), shoulder breadth in meter, Passenger body mass index

Coefficients

Model		Unstandardized Coefficients		Standardized Coefficients	T	Sig.
		B	Std. Error	Beta		
1	(Constant)	8.960	3.153		2.842	.008
	Passenger body mass index	-.694	.275	-1.697	-2.523	.018
	shoulder breadth in meter	10.125	3.887	1.753	2.605	.015

a. Dependent Variable: Passenger's Capacity

**Explore
Descriptive**

	Statistic	Std. Error	
Standardized Residual	Mean	.17616607	
	95% Confidence Interval Lower Bound for Mean	-.3603001	
	Upper Bound	.3603001	
	5% Trimmed Mean	.0178285	
	Median	-.0558705	
	Variance	.931	
	Std. Deviation	.96490128	
	Minimum	-1.71879	
	Maximum	1.33198	
	Range	3.05077	
	Interquartile Range	1.86978	
	Skewness	-.189	.427
	Kurtosis	-1.434	.833

Tests of Normality

	Kolmogorov-Smirnov ^a			Shapiro-Wilk		
	Statistic	df	Sig.	Statistic	df	Sig.
Standardized Residual	.167	30	.033	.914	30	.018

a. Lilliefors Significance Correction

Standardized Residual

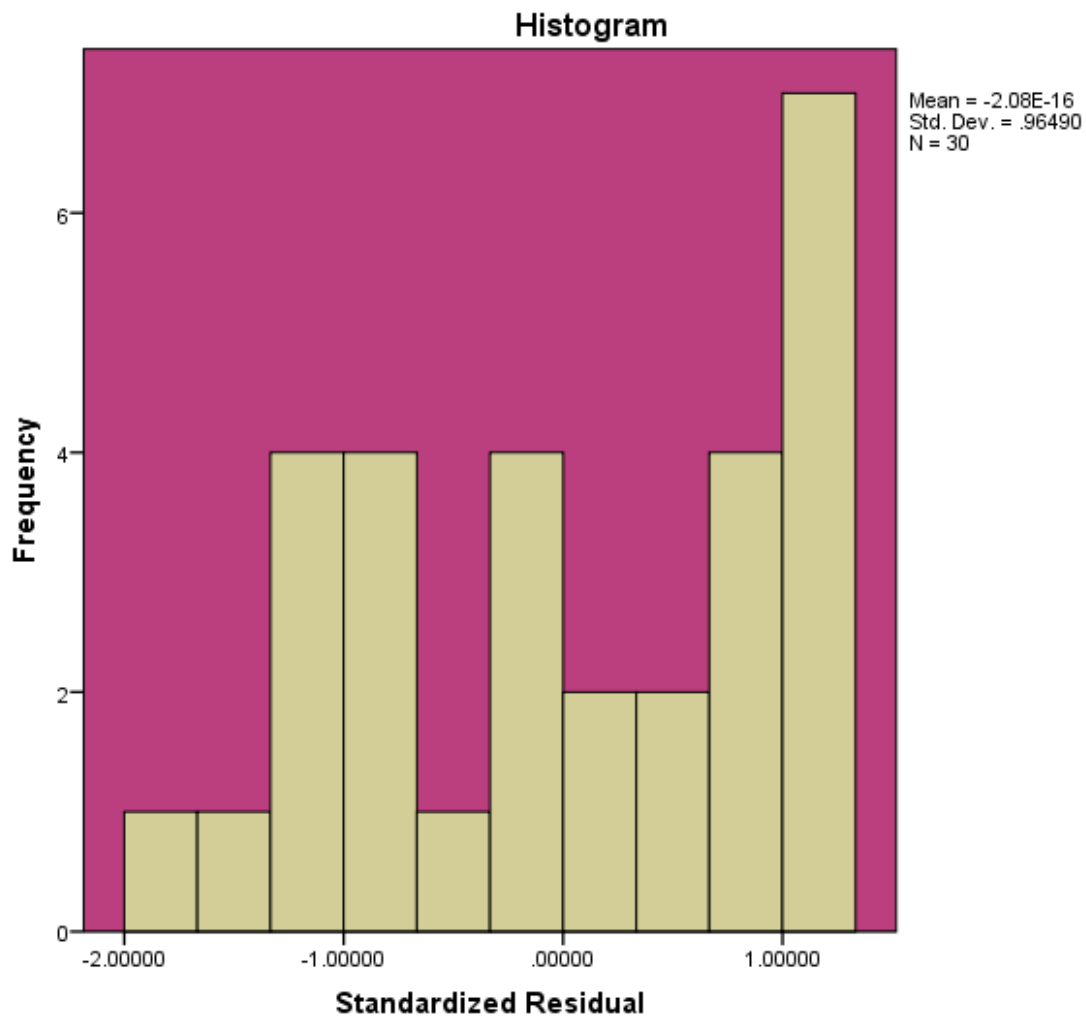

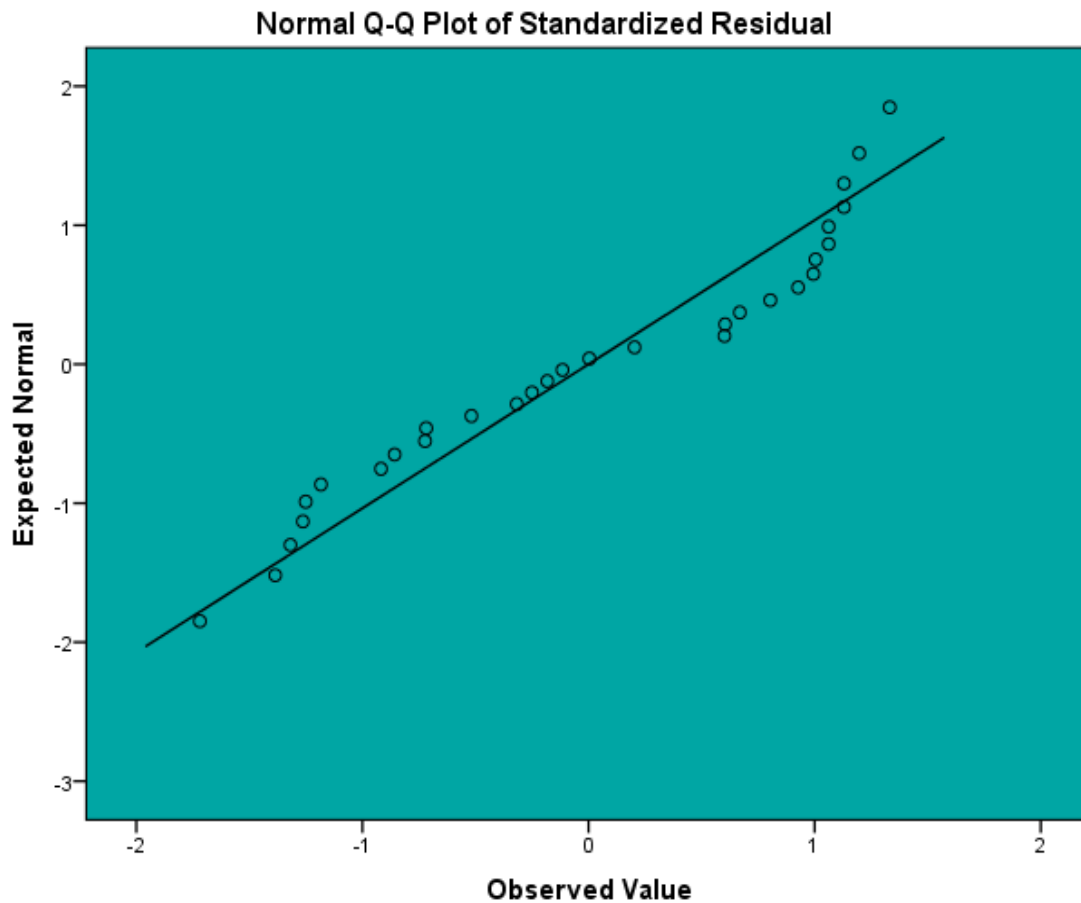

**Model 5
Model Summary**

Model	R	R Square	Adjusted R Square	Std. Error of the Estimate
1	.426 ^a	.182	.121	.47673

a. Predictors: (Constant), body surface area in meter square, Passenger body mass index

b. Dependent Variable: Passenger's Capacity

ANOVA

Model		Sum of Squares	Df	Mean Square	F	Sig.
1	Regression	1.364	2	.682	3.000	.067 ^b
	Residual	6.136	27	.227		
	Total	7.500	29			

a. Dependent Variable: Passenger's Capacity

b. Predictors: (Constant), body surface area in meter square, Passenger body mass index.

Coefficients

Model		Unstandardized Coefficients		Standardized Coefficients	T	Sig.
		B	Std. Error	Beta		
1	(Constant)	6.560	2.463		2.664	.013
	Passenger body mass index	-.667	.281	-1.632	-2.374	.025
	body surface area in meter square	4.350	1.776	1.683	2.449	.021

a. Dependent Variable: Passenger's Capacity

Explore Descriptives

	Statistic	Std. Error
Mean	.0E-7	.17616607
95% Confidence Interval Lower Bound for Mean	-.3603001	
Upper Bound	.3603001	
5% Trimmed Mean	.0222363	
Median	-.1041205	
Variance	.931	
Standardized Residual Std. Deviation	.96490128	
Minimum	-1.72924	
Maximum	1.24233	
Range	2.97157	
Interquartile Range	1.92308	
Skewness	-.137	.427
Kurtosis	-1.467	.833

Tests of Normality

	Kolmogorov-Smirnov ^a			Shapiro-Wilk		
	Statistic	df	Sig.	Statistic	df	Sig.
Standardized Residual	.155	30	.065	.906	30	.012

a. Lilliefors Significance Correction

Standardized Residual

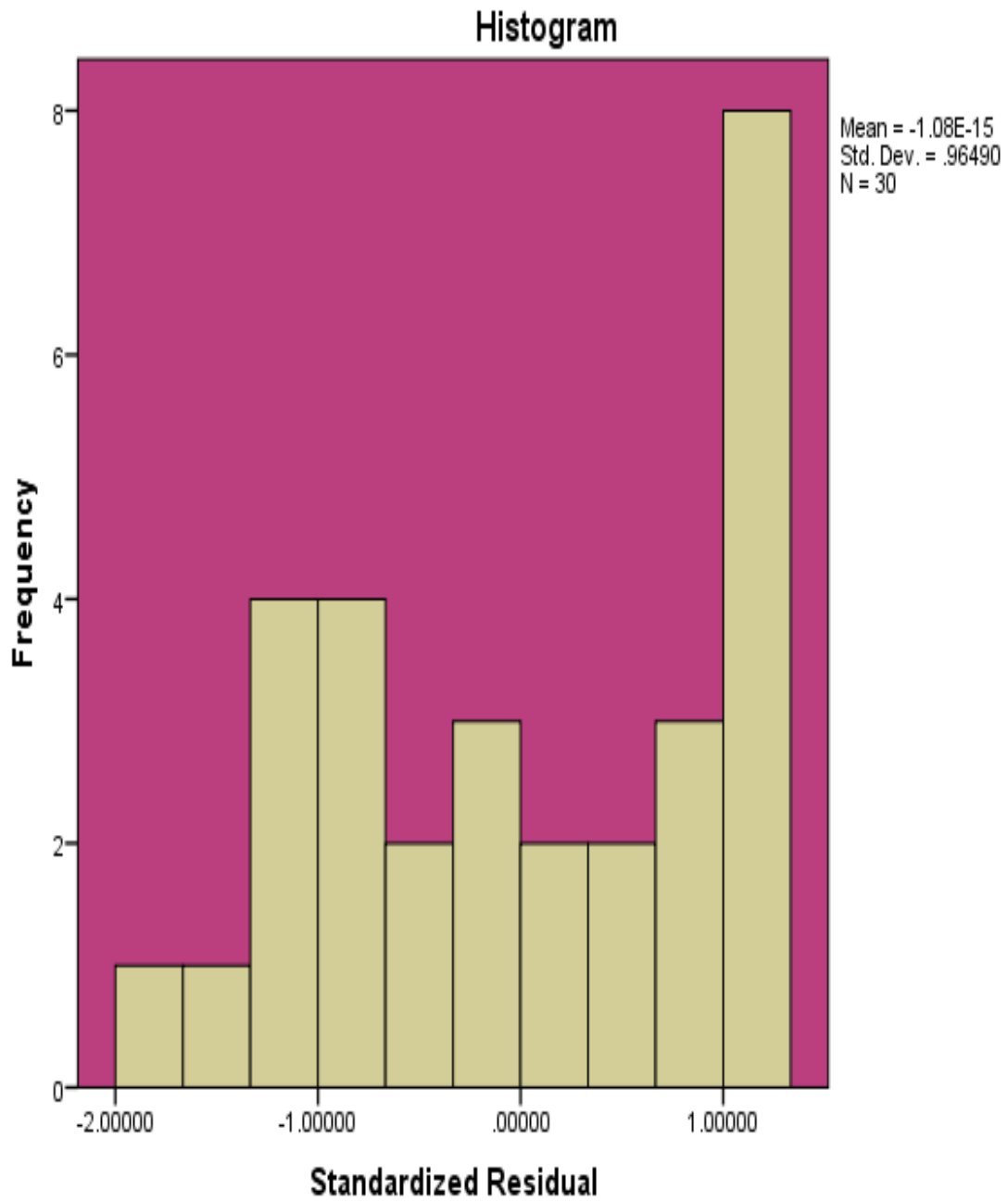

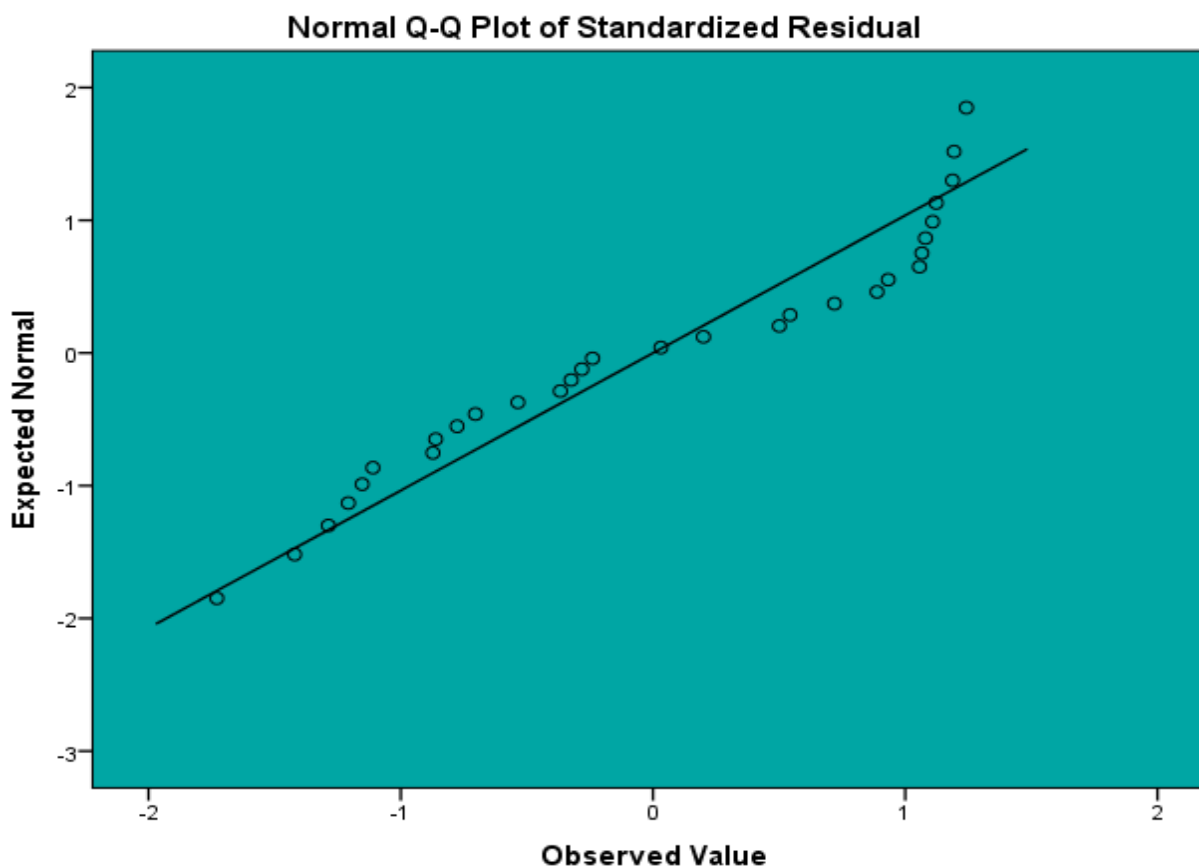

Model 6

Model Summary

Model	R	R Square	Adjusted R Square	Std. Error of the Estimate
1	.448 ^a	.201	.142	.47116

a. Predictors: (Constant), stature in meter, Passenger body mass index

b. Dependent Variable: Passenger's Capacity

ANOVA^a

Model		Sum of Squares	Df	Mean Square	F	Sig.
1	Regression	1.506	2	.753	3.393	.048 ^b
	Residual	5.994	27	.222		
	Total	7.500	29			

a. Dependent Variable: Passenger's Capacity

b. Predictors: (Constant), stature in meter, Passenger body mass index

Coefficients

Model		Unstandardized Coefficients		Standardized Coefficients	T	Sig.
		B	Std. Error	Beta		
1	(Constant)	-2.076	1.924		-1.079	.020
	Passenger body mass index	-.694	.275	-1.697	-2.523	.018
	stature in meter	10.125	3.887	1.753	2.605	.015

a. Dependent Variable: Passenger's Capacity

Explore

Descriptives

	Statistic	Std. Error
Mean	.0E-7	.17616607
95% Confidence Interval Lower Bound for Mean	-.3603001	
Upper Bound	.3603001	
5% Trimmed Mean	.0178285	
Median	-.0558705	
Variance	.931	
Standardized Residual Std. Deviation	.96490128	
Minimum	-1.71879	
Maximum	1.33198	
Range	3.05077	
Interquartile Range	1.86978	
Skewness	-.189	.427
Kurtosis	-1.434	.833

Tests of Normality

	Kolmogorov-Smirnov ^a			Shapiro-Wilk		
	Statistic	df	Sig.	Statistic	df	Sig.
Standardized Residual	.167	30	.033	.914	30	.018

a. Lilliefors Significance Correction

Standardized Residual

