



Addis Ababa University

Addis Ababa Institute of Technology

Department of Mechanical Engineering

Design and Development of a Solar Powered Cooling System to Harness

Potable Water from Humid Air

(A case study in Semi-Arid zones of Ethiopia)

By: Gudeta Wegissa

Advisor: Abdulkadir A. Hassen (PhD)

A thesis submitted to the School of Graduate Studies of Addis Ababa University in partial fulfillment of the Degree of Master of Science in Mechanical Engineering (Thermal Engineering Stream)

May 14, 2019

ADDIS ABABA UNIVERSITY
ADDIS ABABA INSTITUTE OF TECHNOLOGY
SCHOOL OF MECHANICAL AND INDUSTRIAL ENGINEERING
THERMAL STREAM

‘Design and Development of a Solar Powered Cooling System to

Harness Potable Water from Humid Air

(A case study in Semi-Arid zones of Ethiopia)’

By: Gudeta Wegissa

**Approved by board of
Examiners**

<hr/> Chairman, Department Graduate committee	<hr/> Signature	<hr/> Date
<u>Abdulkadir A. Hassen (PhD)</u> Advisor	<hr/> Signature	<hr/> Date
<u>Dr.Yilma Tadesse</u> Internal Examiner	<hr/> Signature	<hr/> Date
<u>Dr. Ing. Wondwossen Bogale</u> External Examiner	<hr/> Signature	<hr/> Date
<u>Dr.Yilma Tadesse</u> School Dean	<hr/> Signature	<hr/> Date

Declaration

I hereby declare that the work which is being presented in this thesis entitled “**design and development of a solar powered cooling system to harness potable water from humid air- A case study in Semi-Arid zones of Ethiopia**” is original work of my own, has not been presented for a degree of any other university and that all sources of material used for this thesis have been duly acknowledged.

Gudeta Wegissa

Date

This is to certify that the above declaration made by the candidate is correct to the best of my knowledge.

Abdulkadir A. Hassen (PhD) (Advisor)

Date

Acknowledgement

First and foremost, I would like to thank my Lord Jesus Christ for me able to complete this thesis.

Secondly, I would like to pass my gratitude to my advisor Dr. Abdulkadir A. Hassen, Assistant Professor of Thermal Engineering at Addis Ababa University, for setting the research area and title about addressing pastoralists who have a critical water problem. His continuous support, suggestion and encouragement helped me complete the research successfully. As a mentor he taught me a lot more than the research at hand.

I would like to extend my sincerely appreciation to Engineer Haeileoul Sahile from staff members of Negarobe Engineering Service PLC's and Oromia Road Construction Enterprise' work shop: General Manager Engineer Numeri Nura, Engineer Wondu Tsega and Ato Negash Kibebew.

I am very appreciative for the exceptionally useful support and commentary of Dr.Wondewosan Bogale, Dr.Yilma Tadesse, Engineer Bayeta Oli, Ato Girma Regessa, Engineer Niguse Mitiku, Ato Endebu G/Silase, Roland V. Wahlgren of Atmoswater Research in Canada and my colleagues.

I also give special thank for Adama wind farm electrical station's management staff for arranging and support me to test a prototype in the compound.

Next, I would like to express my likable thanks to my good wife W/ro Kidist Birhanu and my sons Rober Gudeta and Kabod Gudeta, my daughter Dagim Gudeta and my Sister Warkitu Wegissa, Dodji Wordofa for their encouragement and support throughout the study.

Gudeta Wegissa Reba

May 14, 2019

Abstract

Water shortage is very noticeable in semi-arid parts of Ethiopia where there is hardly any freshwater source at all. Currently, the most interesting method of getting sustainable alternative potable water by harvesting humid from air is continuously under research around the globe. This study was to quantify water from humid air as one of alternative sources using a solar energy prototype targeting semi-arid zone where predominantly pastoralists are living. This paper presents collection of humid air as sand bed introduced to atmosphere at night and a solar thermal regenerative process during day time then extract water from the system.

The main objective of this thesis is to design and manufacture the prototype. The experimental setup consists of composite materials: calcium chloride and river sand as well as the glass box enhancing of capturing moisture from air and facilitate regenerative process. It is obvious that semi-arid has a hot temperature in day time, whereas sand bed is actually cooled at night. Hence, the two windows on the prototype introduce the ambient humid air to pass on the sand bed where the humidity will start adsorb. Whereas the solar glass box is exposed to solar radiation and internal temperature become increase where the evaporation and condensation has begun, the water drops will slide over the inner surface of solar glass and finally collected into the jar through the condensate trough.

Due to weather climates similarity of Yabello and Adama, testing was done at Wind Farm Electrical Station -1, Adama. The result of one day experiment showed that moisture was collect on the sand bed during night and evaporation also successfully collected on the inner surface of the glass. Testing has been performed after good preparation at Adama wind farm Electric station-1 for day and result shows that promising because water condensation on inner surface noticed. But, the numerical result and experimental result did not agree. Low production rate may be the consequence of air leakage, low of humidity amount in the air and low solar radiation intensity. After observing the test result for the effectiveness of the prototype further modification is recommended.

Keywords: Solar glass desiccant box, Adsorption, CaCl_2 , Composite materials, River sand, Semi-arid, Water.

Table of Content

List of Figures:	vii
List of Tables:.....	viii
Acronyms	ix
CHAPTER 1 : INTRODUCTION.....	1
1.1 Background of the study	1
1.2 Statement of the Problem	5
1.3 Objectives of the Study	6
1.3.1 General objectives of the study.....	6
1.3.2 Specific objectives of the study.....	6
1.4 Significance of the study	7
1.5 Scope and Limitation of the study	7
1.6 Thesis Layout	8
CHAPTER 2 : REVIEW OF LITERATURE	9
2.1 Introduction	9
2.2 Potable Water Demand in Semi-Arid of Ethiopia	10
2.3 An alternative source of potable water for Semi-Arid Climate.....	12
2.4 Feasibility of extracting water from atmospheric air.....	12
2.5 Techniques of Harvesting Fresh Water from the Atmosphere.....	13
2.5.1 Liquid water-from – the atmosphere	13
2.6 Atmospheric Water Extraction from Air options	15
2.6.1 Introduction.....	15
2.6.2 Atmospheric Water extraction on cold surfaces.....	16
2.6.3 Extraction of Atmospheric Water Using Desiccants	21
2.7 Typical Cycles in Desiccant Atmospheric Water Extraction.....	26
2.8 Atmospheric Water Generator (AWG) brand in the market	27
2.9 Atmospheric Water Generator Brands in the Global Market.....	28
2.10 Growth of Atmospheric Water Generation in Ethiopia	31
2.11 Mathematical Model	33
2.12 Critical observations from journal papers	36
2.13 Objectives and scope of present work.....	36
2.14 Summarized Literatures as a bench mark	37
CHAPTER 3 : MATERIALS AND METHODS.....	38
3.1 Introduction	38
3.2 Study location and Climatic data.....	38
3.2.1 Location and Accessibility	38
3.2.2 Climate	39
3.2.3 Prototype test location and Climatic data	40
3.1 Data Source and Methods of Collection	41
3.1.1 Data and data sources	41
3.1.2 Method of data collection.....	41
3.2 Design and Manufacturing of the Prototype	42
3.2.1 Determining the Volume of Prototype by output target.....	42

3.2.2	<i>Determining Energy requirement for water harvesting from air</i>	46
3.2.3	<i>Design procedure</i>	48
3.2.4	<i>Selection of Input Material for Prototype</i>	48
3.2.5	<i>Determination of geometry of the prototype</i>	49
3.2.6	<i>Selection of clear Glass as a solar Collector</i>	51
3.2.7	<i>Modeling the Double Slope Solar Glass Box Prototype</i>	54
3.2.8	<i>Design Description</i>	56
3.2.9	<i>Components of the Prototype</i>	57
3.3	Experimental Methods	61
3.3.1	<i>Testing Instruments</i>	61
3.3.2	<i>Area selection for test</i>	63
3.3.3	<i>Mixing ratio of sand and calcium chloride in the prototype setup</i>	63
3.3.4	<i>Measurements and tools</i>	66
3.3.5	<i>Measure and record the amount of water collected.</i>	67
CHAPTER 4 : RESULTS AND DISCUSSION		68
4.1	Introduction	68
4.2	Experimental & Discussion.....	69
4.3	Analytical Result & Discussion.....	72
4.3.1	<i>Introduction</i>	72
4.3.2	<i>Thermal Analysis of Double Flat Plate Solar Glass Cover</i>	74
4.3.3	<i>Evaluating of Output using Psychometric Chart</i>	80
4.3.4	<i>Heat Transfer in Glazing Material</i>	82
4.3.5	<i>Sensitivity Analysis for chosen variables</i>	83
4.3.6	<i>Thermal theoretical system efficiency</i>	90
4.3.7	<i>Comparison of experiment and Analytical Results</i>	90
CHAPTER 5 : CONCLUSION & RECOMMENDATION		91
5.1	Concluding Discussion.....	91
5.2	Recommendation for Future Work.....	92
CHAPTER 6 : APPENDIX		94
6.1	AWG Suppliers List.....	94
6.2	Dewpoint Calculator Software [67].....	98
6.3	Types of air.....	98
6.4	Definition of key concepts used in this thesis	100
6.5	Bibliography	101

List of Figures:

Figure 1-1: Distribution of semi-arid tropical regions in the world [2]..... 1

Figure 1-2: Ethiopian Map Climate Classification [8].3

Figure 2-1: Solar radiation potential of Ethiopia Wh/m2 [12].....9

Figure 2-2: World humidity classes [15] 10

Figure 2-3: People taking potable water from unsafe sources. 11

Figure 2-4: Locations where fog collection has a high potential for..... 13

Figure 2-5: Concentrated surface [19] & [20]..... 14

Figure 2-6: Project design of Atmospheric Water Generator 16

Figure 2-7: Model Water harvesting using Refrigerator system [26]. 17

Figure 2-8: Membrane facilitated water generation from air humidity 19

Figure 2-9: MOF typical water harvesting technology [30] 20

Figure 2-10: Schematic diagram for Solar Glass Desiccant box type System [32] 21

Figure 2-11: Schematic diagram of experimental test rig 22

Figure 2-12: Schematic diagram for Solar Glass Desiccant box type System [34] 23

Figure 2-13: Water production from atmospheric air [33] 24

Figure 2-14: Scheffler reflector Techniques used for water harnessing [35] 25

Figure 2-15: Conceptual scheme of the adsorption/desorption cycle [23] 26

Figure 2-16: Typical Commercial Atmospheric Water Generator [36] 27

Figure 2-17: Sun-To-Water working principle [30] 28

Figure 2-18: Konia Water [37]..... 29

Figure 2-19: SKY water Technology 30

Figure 2-20: Water collector from air, Source “WarkaWater”. 31

Figure 2-21: Storing Water in Various Mediums..... 32

Figure 2-22: Flat plate Solar Collector 34

Figure 3-1: Map of Study Area from GPS [46] 38

Figure 3-2: Sunshine & Relative Humidity to determine design month (interpolated) 40

Figure 3-3: Wind Farm area..... 40

Figure 3-4: Heat flow through a Flat Plate solar collector [55] 47

Figure 3-5: Flat surface double slope solar still 50

Figure 3-6: Energy profile of collectors with different glass thickness [59] 52

Figure 3-7: Temperature profiles of collector with different glass thicknesses [59] 52

Figure 3-8: Ash Box and Sand Box assembled Model..... 54

Figure 3-9 : Assembled Model of the Prototype 54

Figure 3-10: Drawing Model 55

Figure 3-11: Stand of Solar Desiccant Box 57

Figure 3-12: Ash Box 58

Figure 3-13: Sand Box..... 58

Figure 3-14 : Solar Glass box system..... 59

Figure 3-15: Plastic bottle wrapped with Jute..... 60

Figure 3-16: Five in one Environmental Meter..... 62

Figure 3-17: Thermometer 63

Figure 3-18: Prototype Pictorial representation 65

Figure 4-1: Picture of the prototype 68

Figure 4-2: HI 92801C K-Thermocouple [le picture during test 69

Figure 4-3 Test Result Temperature versus Time 70

Figure 4-4: Picture of water condensation on inner surface of the glass.....	71
Figure 4-5: Prototype Detailed Section View	74
Figure 4-6: Energy flow diagram for the proposed system [63].....	75
Figure 4-7 : The Psychrometric Representation of DBT, WBT, DPT and RH.....	81
Figure 4-8 : Effect of Solar radiation.....	83
Figure 4-9: Effect of ambient Temperature on Relative Humidity	84
Figure 4-10: Maximum amount of water vapor that can be contained in a cubic meter of air over a wide range of temperatures.....	85
Figure 4-11: Hourly system vapor pressures for different bed materials [22].....	87
Figure 4-12: Hourly system productivity and evaporation for different bed materials [22].	87
Figure 4-13: Hourly system efficiencies for different bed materials [22].	88
Figure 4-14:CaCl ₂ concentration effect	89
Figure 4-15: Typical System efficiency [44]	90

List of Tables:

Table 2-1: Major stocks of fresh water [16]	12
Table 2-2: Energy consumption and water production air handling unit [27].....	18
Table 2-3: A comparative summary of Studies conducted.....	37
Table 3-1: Yabello (Latitude 6°83'N, longitude 38°5'E, 1729m a.s.l) 2014-2016.....	39
Table 3-2: Adama (Latitude: 8.5263°N, longitude: 39.2583°E, 1712 m) 1995 – 2007 [49] & [50]	41
Table 3-3: Max. Partial pressure of water vapor in atmosphere [52].....	45
Table 3-4: Solar Irradiance Figures on Adama/Nazareth measure in kWh/m ² /day onto a horizontal surface [53]	46
Table 3-5: Properties of CaCl ₂ Hydrates [56].....	48
Table 3-6: Selection of Inclination Angle of Solar Glass [58]	51
Table 3-7: Sizing of the Prototype.....	51
Table 3-8: Thermo physical properties of glass [60].....	53
Table 3-9: Design parameters [33].	53
Table 3-10: Actual Prototype Production	56
Table 3-11: Overall Project Expenses	57
Table 4-1: Prototype internal temperature	70
Table 4-2: Specification of double slope Flat solar Collector [34].	73
Table 4-3: Regression constants.....	79
Table 4-4: Bed Materials [22].....	86
Table 4-5: Test Comparison.....	90
Table 5-1: Possibility of importing AWG and potential of usage.....	93
Table 6-1: AWG Supplies List Summary [66]	97
Table 6-2 : Moisture Content in one cubic air base on ambient temperature at standard atmospheric pressure	99

Acronyms

CRU	Climate Resource Unit
NMA	the National Meteorological Agency of Ethiopia
OXFAM	Oxford Committee for Famine Relief
CFD	Computational Fluid Dynamics
AWG	Atmospheric Water Generator
AI	Aridity Index
MOF	Metal Organic Framework
CaCl ₂	Calcium Chloride
SGDBS	A solar glass desiccant box type system
WHO	World Health Organization
KSA	Kingdom of Saudi Arabia
DBT	Dry Bulb Temperature
DSC	Differential Scanning Calorimeter
RTV	Room temperature vulcanized
SRRA	Solar radiation resource assessment
Ditto	the same things again

Chapter 1 : Introduction

1.1 Background of the study

Global distributions of semi-arid climates are indicated by Krishnamurthy L [1] in the fig.1-1. Ethiopia has also areas covered by semi-arid districts at its southern and northern borders.

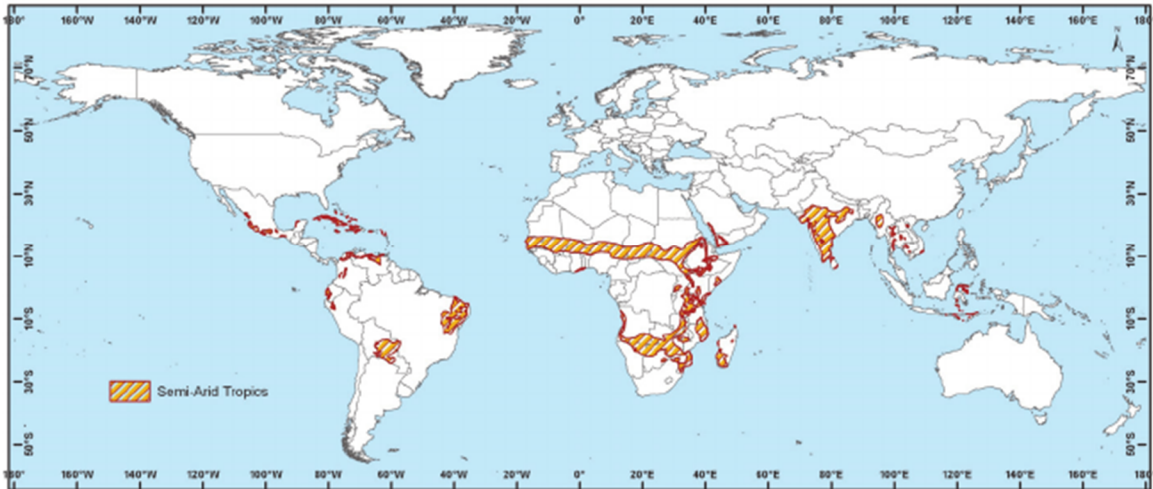

Figure 1-1: Distribution of semi-arid tropical regions in the world [2]

Ethiopia is blessed for it has 11 major lakes with a total area of 7,400 km², 12 river basins with a total annual surface runoff of about 110 billion m³. And ground water with an estimated of Volume 2.56 billion m³ explained by Thewodros Bekele and Seyoum Leta [3]. Yet, half of the population has no access to an improved water supply in this country. Moreover, WaterAid in its brief report of 2016 [4] categorized Ethiopia among the top 10 worst countries for household water access.

The terrains of Ethiopia consist of a huge central plateau and surrounding lowland plains, producing three climatic zones: tropical in the south and southwest, arid to semi-arid in the northeastern and southeastern lowlands, and cooler in the highland region located in the central part of the country as highlighted by Tenna Shiterek [5]. This geography challenges Ethiopia to easily transport water from big rivers to region where there is a severe shortage.

Most of Ethiopia's semi-arid zone is characterized by drought, high temperatures, high winds, high radiation, and dust. This zoned has good solar energy potential. A report from the Institute for Environmental Studies [6] identified that the Borena area is exposed to various problems: Ground water is distributed unevenly and is often very deep;

overexploitation has led to dropping groundwater levels and wells running dry. On the other hand, this report indicated there are no perennial rivers and rainfall varies highly, both spatially and temporally. Therefore, the rural communities in Borana have insufficient access to clean potable water.

Sources of water used for human life and activities are obtained from different sources: traditional water sources and modern/improved water sources. However, water needs for agriculture, food production and potable are still scarce and this scarcity is becoming an actual threat in the near future. To address **this scarcity, the focus of this study is the alternative of accessing directly the atmospheric water vapor.**

An unpublished paper from France written by D. Beysens and I. Milimouk [7] confirmed the atmosphere in general contains 12,900km³ of fresh water, composed of 98% water vapor and 2% condensed water (cloud).

Data from National Meteorological Agency of Ethiopia indicated that *Semi-arid* of Ethiopia characterized by less precipitation or less rainy season. The weather is warm and humid. In most places there is no river as compared to highland. 1.9 liters of water is required per person per day for to satisfy the basic physiological need for hydration. Another battle to get fresh, women in the area travelled about 6kilometer on every day. Hence, using conventional ways provisions of potable water is one of the challenges in this area. On the other hand, now a day atmospheric air becomes alternative source to harness water for home consumption without travelling several kilometers. To use this resource targeting to solve the sever water shortage; this research work has been initiated to be done in such a way that prototype is required to quantify the amount of water and increase the size to meet the demand per families. Map of semi – arid of Ethiopia is indicated in figure below.

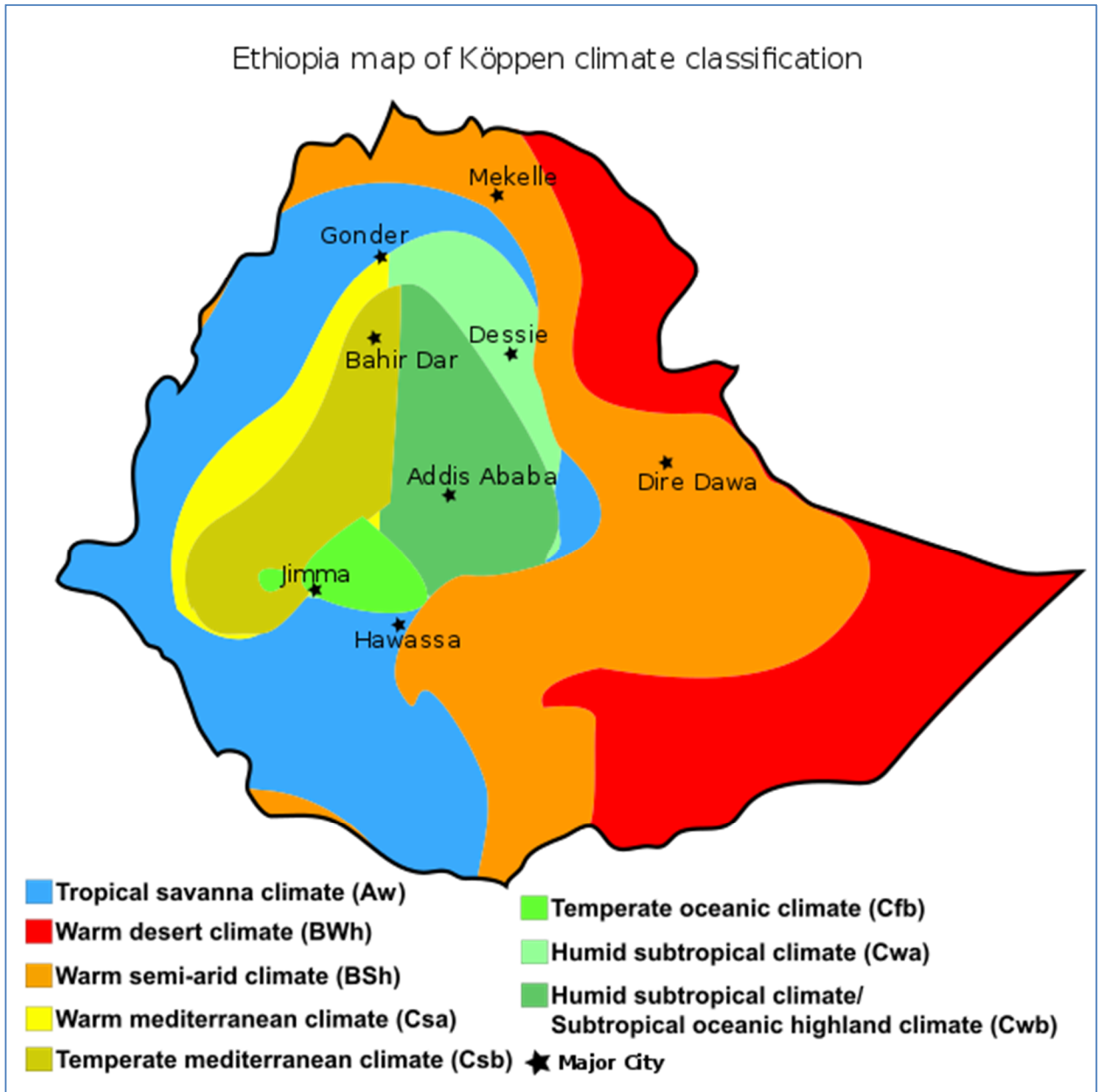

Figure 1-2: Ethiopian Map Climate Classification [8].

Atmospheric water can be one of the proposed future solutions for the production of fresh water since Ethiopia; especially in the semi-arid zone has an extra ordinary intensity of solar radiation during most days of the year. Moreover, this renewable energy source could be used efficiently as replacement for traditional ways of dew collection to get potable water in the arid zones [9]. Naturally; the semi-arid zone is characterized by uniform warm temperature. The important factor in harvesting water from air is humidity of the surrounding. According to the global humidity index, the world has a diverse range of potentially useable air to create water resources. Figure2-2 reveals the humidity index of the world along with dry regions, according to the Climate Resource Unit (CRU) of the University of East Anglia of the United Kingdom (Grid-Nairobi And University of East Anglia's Climatic Research Unit 1991). This index may give an indication of the concentrated humidity areas across the world and provide a better understanding of where the water harvesting methodology can be most effective.

A relatively new method absorbs water and water vapor from incoming air using salt (desiccant) and solar heat to bake the water out of the salt and into a closed loop of hot humid air. Then, the hot humid air is funneled through a condenser where water extraction is finalized. This system is different from conventional cooling devices in that it has no moving parts, fluids or gasses and no need of a pump and compressor at all [10].The main objective of this research is targeting the dry zone of Ethiopia to study ways to obtain potable water from atmospheric air, giving attention to investigate the technological design options such as operating a solar powered cooling system from renewable sources. Low cost operation is needed to address the low income of people in the area in which we want to produce water from humid air.

1.2 Statement of the Problem

Even though, the technology of water production from humid air using wind turbine powered systems already exists and has been used in Saudi Arabia and India near to coastlines, this young technology has not yet been tried in Ethiopia. In many zones of pastoral-semi-arid areas of Ethiopia finding potable water requires traveling several kilometers to water points. According to Chuan's study [11] the travel distance or water hauling distance to a water point in for example the Borana zone is on average 14.5km. OXFAM published a country report about Ethiopia by Tenna Shitarek [5]. In the pastoralists' area during drought women, girls and children need to travel long distances (between 5 and 8 hours) in search of water from unprotected sources.

Furthermore, during the dry season most water points become dry and water scarcity challenges the people living in the semi-arid areas. It is this problem that motivated me to design water harvesting devices. The study proposes potable water harvest from humid air in the semi-arid zone of Ethiopia. Obtaining potable water from humid air by a solar powered cooling system will be a great benefit by **providing alternative potable water from air** in the pastoralists'-areas focusing in the semi-arid climatic environment. **The system is self-contained so no cost is incurred connecting to the electrical grid.** Hence, in this research novel potable water from humid air technology is designed, developed and tested so that a prototype is ready for the community. The technology is intended to be a low cost device by using the renewable energy sources available in the local area. The goal is to serve the semi-arid zone population of Ethiopia in general.

Semi-arid zone of Ethiopia has a good potential of solar energy and humid air, a key for producing water using condensation system on desiccant materials or simply put appropriate size of commercial atmospheric water generator machine. This research work basically has seen the battle of getting water in the areas and as a thermal engineering profession using the theory of condensation and regenerative cycles of moist air, this novel ideal has put into practice as a prototype to verify the feasibility of getting water from humid air and finally maximize the output by adding six and adding certain features like fan used to force incoming air and installing solar panel. So, the idea of getting potable from humid air basically reducing the cost burden of getting water from ground and connecting water pipes to transport water long distance.

1.3 Objectives of the Study

1.3.1 General objectives of the study

The main objectives of this study are: assessing atmospheric water and solar resource potential; designing, manufacturing and quantifying experimentally the potable water production per day using the prototype device in the humid air of Yabello in Oromia, Ethiopia using power from renewable energy source. The experimental investigation determines the amount of water produced per day per device with emphasis on solar energy and humid air.

1.3.2 Specific objectives of the study

Specific objectives of the research are:

1. Determining solar energy potential and humidity of air for the design condition
2. Designing and modeling of atmospheric water harnessing device using appropriate software.
3. Development of a prototype for extraction of water from humid air
4. Experimental investigation of the system considering available solar radiation data, and output per square meter per day.

1.4 Significance of the study

In many zones of pastoral and semi-arid areas of Ethiopia getting to potable water points takes several kilometers of travel. Furthermore, during dry season most water points become dry and water scarcity challenges the people living in the semi-arid area. To provide potable water for the households the government engaged in huge investments to drill deep wells and install electric transmission lines or diesel generators to pump water to Pastoralists and farmers in semi-arid parts of Ethiopia.

The result from the study shows atmosphere humid air is a sustainable alternative for small scale potable water. Solar energy arranged for heating the device could also be a power generation source and could be a step forward to reduce dependency on the National electrical grid.

Benefits of using atmospheric water vapor processing include reducing the cost related to drilling deep wells and installing electric transmission lines. The extraction of water from atmospheric air is a beneficial method for fresh water production in semi-arid regions and small communities that are dependent on water existence (ground, or underground), so it is a reliable solution for decentralized societies that couldn't cope with the high initial cost or labor affairs. Thus, obtaining potable water from humid air by solar powered cooling systems will be a great benefit by solving potable water scarcity in the areas, and the system uses self-contained energy with no cost incurred for the National electrical grid. In addition, this research can motivate the government to invest on large capacity AWG devices either by importing or by encouraging investors to manufacture AWGs in Ethiopia. Moreover, this paper can be useful as a reference for further study in the area.

1.5 Scope and Limitation of the study

The scope of this research is to design, manufacture and test the prototype based on design specification and available materials. After the test on the experimental investigation, conclusion and recommendation will be drawn based on the test results. The limitation of this research work is that the experimental investigation was done in Adama, and may not apply for other regions in the country. Moreover, laboratory tests on prototype and water treatment to add minerals, removing bacteria using ultraviolet light is left for further study on the field. In other word, all other functions not related to the project will be ignored.

1.6 Thesis Layout

The present study is organized into six chapters:

Chapter one:

This chapter gives a general introduction to semi- arid's potable water challenges, , introduce the study's statement of the problem, the objectives of the study, significance of results, and the scope and limitations of the study.

Chapter two:

It reviews the literatures with regards to potential of solar energy and humidity of air specifically in semi-arid areas, technological advancement and research that have been done about potable water harnessing, hazards of potable water in Ethiopia, previous studies on atmospheric water generation in Ethiopia, and typical devices currently in the global market as atmospheric water generators (AWGs).

Chapter three:

This chapter discusses materials and methods mainly design, modeling and manufacturing of the prototype and operating principles of the prototype.

Chapter four:

This chapter is about result and discussion regarding the test result discussion, the analytical result, the comparison and analysis of the experiment conducted in Adama.

Chapter Five:

This is about the conclusion and recommendation of the study.

Chapter Six:

This is about Appendix.

Chapter 2 : Review of literature

2.1 Introduction

Various research journals have stated that Atmosphere contains about $12,900\text{km}^3$ of water in vapor form and in cloud form. Hence it can be used as a new and renewable water source. Various researches have been conducted and prototypes have also been constructed to prove the technology of harvesting atmospheric water vapor. However, the atmospheric water generation research is still undergoing.

The probable reason of in recent years the problem of fresh potable water supply has intensified in many communities especially in arid and semi-arid areas. This has shown there is research gap with the researchers are still working on finding the best ways of obtaining water directly from the vapor in the air. Perhaps the most feasible energy for air- water condensation in the remote areas is solar energy. According to a study by Samuel and Getachew [12] solar radiation reaching the ground in Ethiopia on a daily average basis is $5.5 \text{ kWh/m}^2/\text{day}$ and different sites have different solar radiation per day as indicated in the figure 2-1. The existence of these renewable solar and atmospheric water resources encouraged my study to be started.

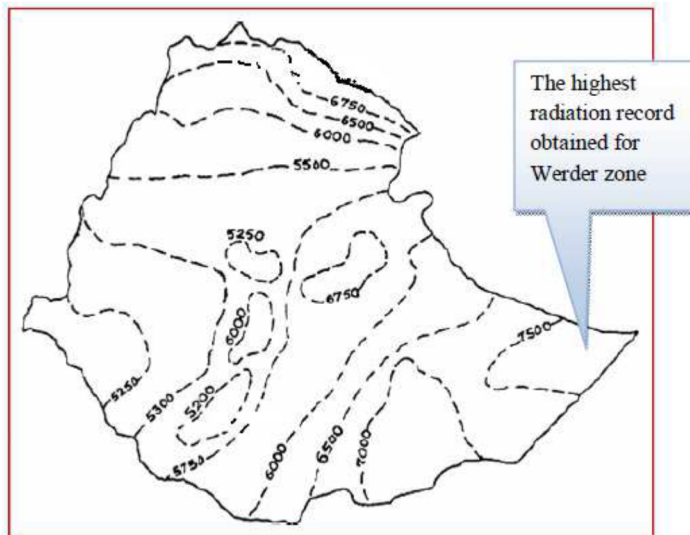

Figure 2-1: Solar radiation potential of Ethiopia Wh/m² [12]

2.2 Potable Water Demand in Semi-Arid of Ethiopia

The focus area of this study is in the Ethiopian Rift valley in Yabello. According to A. Russell- Smith [13] climatic classification in the area of the Rift Valley includes four zones:

- Arid zone: median annual rainfall less than 400 mm.
- Semi-arid zone: median annual rainfall between 400 and 700 mm.
- Sub-humid zone: median annual rainfall between 700 and 1000 mm.
- Humid zone: median annual rainfall above 1000 mm.

As dry lands are classified into four ranges of the Aridity Index (AI, the ratio between the mean annual precipitation and the mean annual potential evaporation) [14]:

- Hyper arid, $AI < 0.05$ (7.5 % of global land area);
- Arid, $0.05 < AI < 0.20$ (12.1 % land);
- Semi-Arid, $0.20 < AI < 0.50$ (17.7 % land);
- Dry sub humid, $0.50 < AI < 0.65$ (9.9 % land)

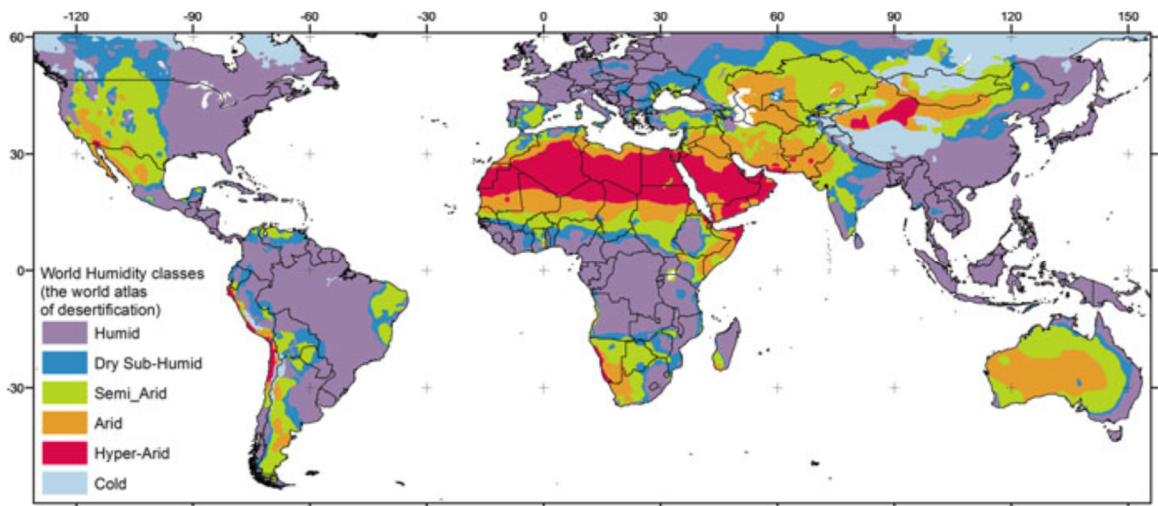

Figure 2-2: World humidity classes [15]

Water shortages and scarcity are daily issues for Ethiopians irrespective of in which region of their country that they live. The significance of the problem is most acute in the low land of the country where the area is vulnerable to drought and most of the water sources are underground. Ground water is distributed unevenly and is often very deep. In the semi-arid zone where the majority of pastoralists are living, water is a key element for survival so conflicts happening at water points. The volume of potable water required per person per day in Ethiopia is estimated to be 5 liters. Peoples in semi-arid zones of Ethiopia traditionally got water without giving attention for its purity. Whether safe or not, they simply fetch and drink and use the water for home consumption. According to country report from Action for development [6] showed that people taking water for domestic use and drinking from open surface ponds that are unsafe. This pictorially indicated in following figure 2-3.



Figure 2-3: People taking potable water from unsafe sources.

With the solar energy and humid air potential in the district, water harvesting from atmospheric water vapor could be one of the alternative sources for the pastoralists.

2.3 An alternative source of potable water for Semi-Arid Climate

According to the study explained and official publication on E- water [16], Atmospheric water vapor is known to be an abundant water reservoir in the humid climate. The arid to semi-arid zones have also large solar potentials. The significance of water content in the atmosphere is estimated six times larger than in all rivers on Earth. Alternative water sources are identified in the table below [16].

Table 2-1: Major stocks of fresh water [16]

Fresh water source	Volume (1000km ³)	% of total water	% of total fresh water
Glacier, permanent snow cover	24,064	1.74	68.7
Fresh groundwater	10,530	0.76	30.06
Ground ice, permafrost	300	0.022	0.86
Fresh water lakes	91	0.007	0.26
Soil moisture	16.5	0.001	0.05
Atmospheric water vapor	12.9	0.001	0.04
Marshes, wetlands	11.5	0.001	0.03
Rivers	2.12	0.0002	0.006
Incorporated in biota	1.12	0.0001	0.003

2.4 Feasibility of extracting water from atmospheric air

Scarcity of potable water is noticeable in low lands and where there are no available rivers, lakes and there is lack of rainfall. A study by a group of researchers: Ben Gido, Eran Friedler and David M. Broday [17] showed that by 2025 two thirds of the worldwide population is expected to live in regions with water scarcity. As an atmospheric water vapor is a potential source of a plentiful amount of freshwater that is accessible everywhere. Hence, alternative water sources and doing similar research to find technologies for potable water production are early warning research solutions for tropical areas.

2.5 Techniques of Harvesting Fresh Water from the Atmosphere

2.5.1 Liquid water-from – the atmosphere

A study conducted in Israel by Faculty of Civil and Environmental Engineering, Technion - Israel Institute of Technology, Haifa [17] found that of the total fresh water contained in the atmosphere of $12,9000 \text{ km}^3$, only 2% exists in a liquid phase (cloud droplets, fog). Liquid water is easier to capture, as naturally done by vegetation and animals. By the same analogy man-made fog traps (net structures) have been practiced to capture water droplets from the air. Study conducted by Jeremy K. Domen [18] indicated that frequent and predictive fog events occur only in specific places that enjoy favorable conditions thus: on a large scale it is even less accessible than any other source. Best coastal places for fog water harvesting areas are indicated in the fig. 2-4 below.

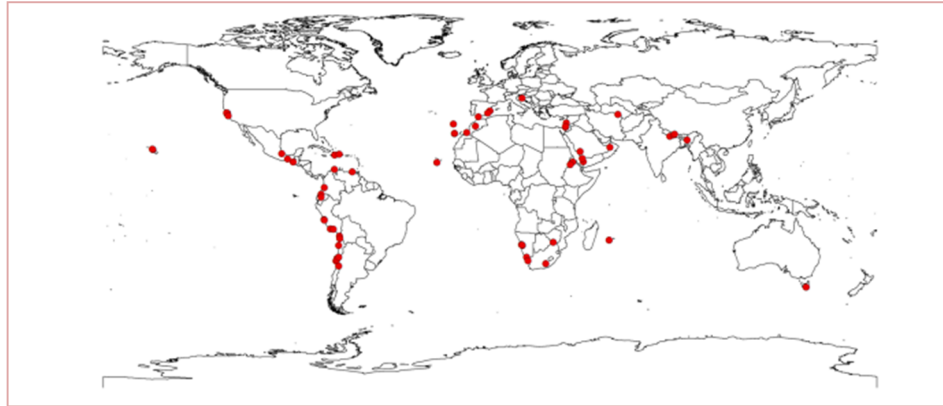

Figure 2-4: Locations where fog collection has a high potential for

a) Fog Harvesting experience In Benin using Local material

To solve water scarcity in Benin a motivated Gabin Koto N'Gobi tried to design a dew collector using local made device with its concentrated surface as indicated in figure 2-5, his prototype was made out of local materials making it an accessible technology for communities and farmers [19].The researcher was able to harvest up to 4 liters of water per night.



Figure 2-5: Concentrated surface [19] & [20]

According to Erik [19] water extraction directly from air by cooling the air to its dew point was not efficient when relative humidity drops under 30%, or when the air temperature drops below 18°C. Hence, more efficient methods using desiccant and applying solar energy potentials were proposed.

2.6 Atmospheric Water Extraction from Air options

2.6.1 Introduction

According to a study by Ben Gido [21], water vapor is prevalent in the atmosphere but its harvesting is more thermodynamically complicated than fog harvesting since the vapor must be condensed to liquid water - a process that involves significant release of heat ($\sim 2500 \text{ kJ/k}_{\text{gw}}$).

A study by Mohamed from Egypt [22] briefly explained that commonly there are two methods for water extraction from atmospheric air using solar energy are dew point and absorption regeneration techniques.

..... “Cooling moist air to a temperature lower than the air dew point temperature using solar cooling system is called dew point technique. While, the absorption-regeneration cycle depends on absorption of moisture from atmospheric air during the night time by desiccant material then, regeneration the absorbed water during day time by solar energy as heat source”.

The possibility of using ambient air as a potable water source has been studied and tested in various research journals and thesis around the globe. A Study by V. Gentile [23] identified two main options:

1. Use a refrigeration cycle based on vapor compression heat pumps or absorption chillers, to cool the air under dew point and condense the moisture.
2. Use sorption materials to subtract the water vapor contained in the atmosphere. Afterwards the material is regenerated and the water is condensed at ambient temperature.

A research conducted by Girja Sharan [24] on semi-arid coastal region of northwest India found potable water from dew over a plastic roof on a greenhouse. This technology employed natural phenomena of radiation cooling to affect condensation without the use of any external energy. However, there is a limitation applying in Ethiopian climates since it is effective only in coastal areas near the sea or lakes.

2.6.2 Atmospheric Water extraction on cold surfaces

a) Solar Water Condensation Using Thermoelectric Coolers

A thermoelectric cooler is made of two dissimilar conducting materials forming a junction where one side gets hot the other side becomes cold just analogous to the thermostat in water cooled motor vehicle engines. The system employed in thermoelectric coolers is a solid state devices heat pump without moving parts, fluids or gasses. Moist air is pumped first into the hot side of the Peltier element to increase the air temperature and at the same time cool the hot side of the element. The air is then made to flow to the cold side to condense the water moisture, as shown in Figure 2-6 [25]. The typical output of this system is 1 liter of condensed water produced per hour during the day.

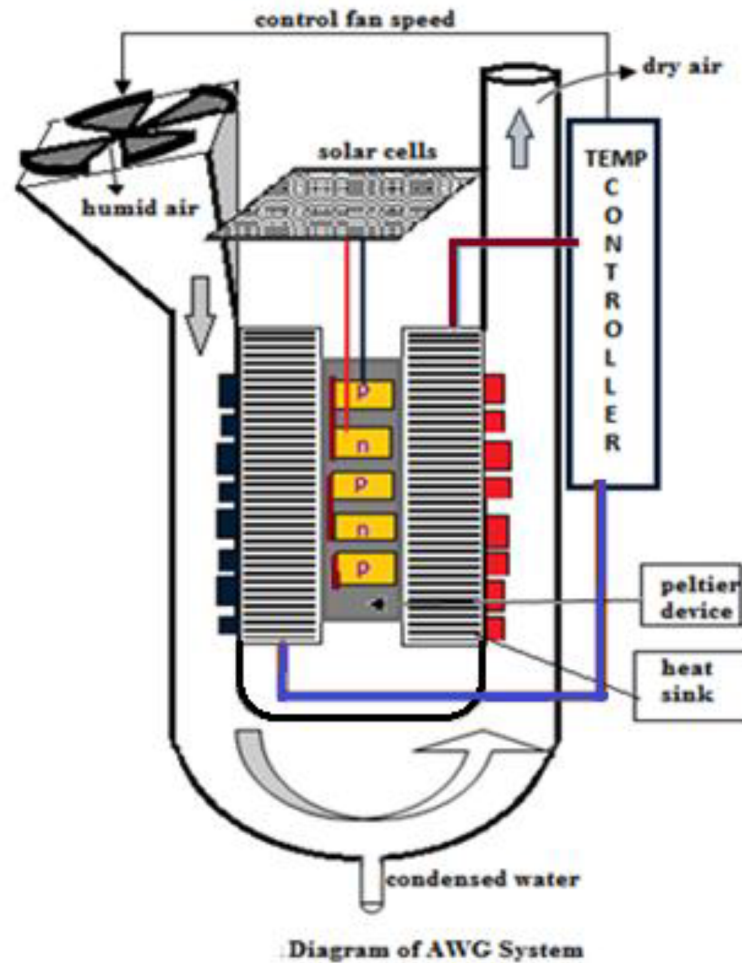

Figure 2-6: Project design of Atmospheric Water Generator

b) Atmospheric Water Harvesting using Refrigerator Cycle

Other than natural dew collection, Sankha dip Das (Dr.) has taken the initiative to motivate researchers about how to achieve potable water by Atmospheric water generators in 100s of gallons of water per day by condensing water vapor in atmosphere and he postulates the innovative idea using the first class of device which is to cool a surface below the dew point of the ambient air as indicated figure 2- 7.

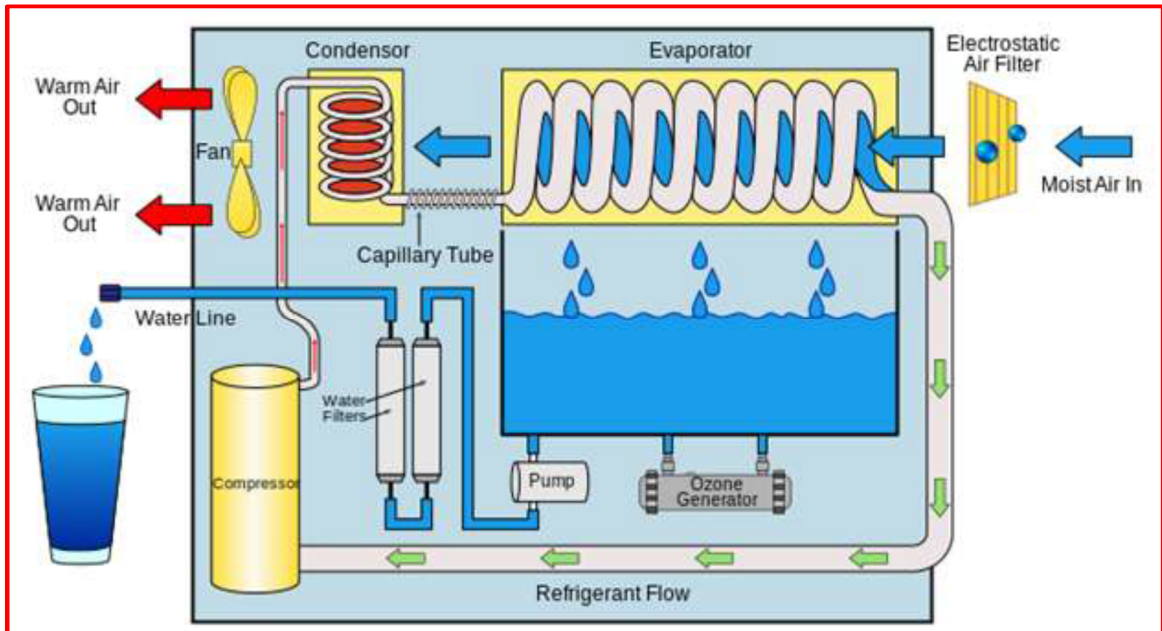

Figure 2-7: Model Water harvesting using Refrigerator system [26].

c) Atmospheric Water Harvesting using integrated AHV system

A study by researchers Magrini A.a, Cattani L.b, Cartesegna M.C., Magnani L.a [27] designed a dual purpose water production and air-conditioning system for emergencies or exceptional events or for when potable water is temporarily not available. When the dual system is operated in the specific climatic conditions ($T_{\text{outdoor}} = 35^{\circ}\text{C}$, $\text{RH}_{\text{outdoor}} = 60\%$; $T_{\text{indoor}} = 20^{\circ}\text{C}$, $\text{RH}_{\text{indoor}} = 60\%$) and for continuous operation at full load. The output of water production and energy consumption of this system is as shown in the table 2.2 below.

Table 2-2: Energy consumption and water production air handling unit [27]

Illumination Terms	TS - typical system		IS – Innovative System	
	Rooms	Common Areas	Rooms	Common Areas
External air [m ³ /h]	30,000	150,000	30,000	150,000
Recirculated air [m ³ /h]	0	150,000	0	150,000
Recovered heating power [kW]	0	361.50	215	1340
Cooling power battery packs [kW]	565.7	3463	517	3650
Post- heating battery pack [kW]	82.2	123.5	0	337.5
Electric power for refrigeration [kW]	177.9	1117.10	180.9	1248
Fans Electric power [kW]	16.2	205.6	23.9	231.5
Chilled water pump electric power [kW]	7.5	55	7.7	55
Post-heating water pump electric power [kW]	1.2	1.0	0	5.5
Condensed water [m ³ /day]	11.0	66.4	12.4	72.2
Energy consumption [Kwh/day]	4867	33089	5100	36960
ENERGY CONSUMPTION	37,956 kWh/day		42,060 kWh/day	
TOTAL CONDENSED WATER	77.4 m³/day		84.60 m³/day	

Where:

- TS - Typical HVAC System
- IS - Integrated air conditioning System

d) Atmospheric Water Harvesting with membranes

A study conducted by a group of researchers [28], as a ‘Design of a system for humidity harvesting using water vapor selective membranes’ used a hollow fiber membrane, vacuum pump, recirculation pump and fan. The result from the combined thermodynamic and feed side analysis of the membrane module, evaluated for environmental conditions, was a water production performance of approximately 2.5 l/m^2 day. Figure 2-8 shows the model.

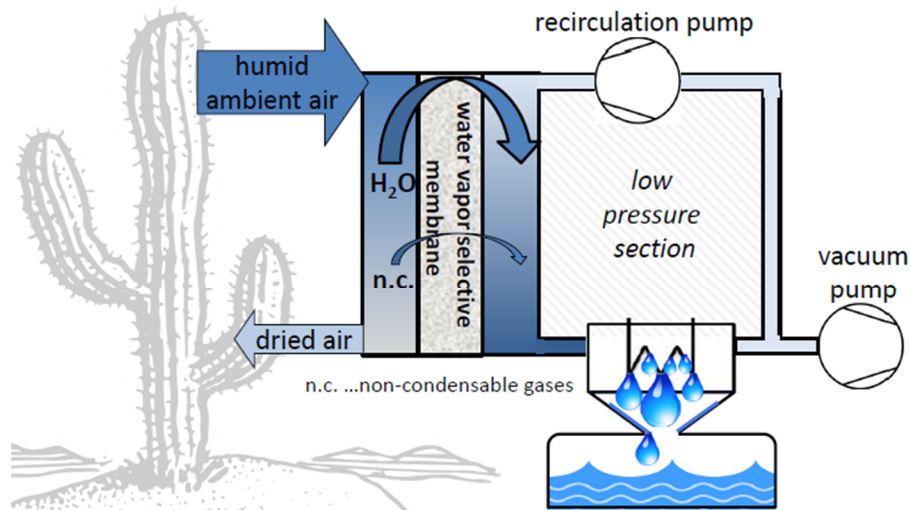

Figure 2-8: Membrane facilitated water generation from air humidity

e) Water Harvesting using MOF technology

Recently, an American technology institute has developed porous crystalline powders which are called metal organic frameworks, or MOFs to harvest water vapor from air. The solar-powered device can pull water straight from the desert air using sponge like devices that uses sunlight to suck water vapor from air, even in low humidity. The researcher is also hoping that the device can produce nearly 3 liters of water per day for every kilogram of sponge like absorber it contains [29].

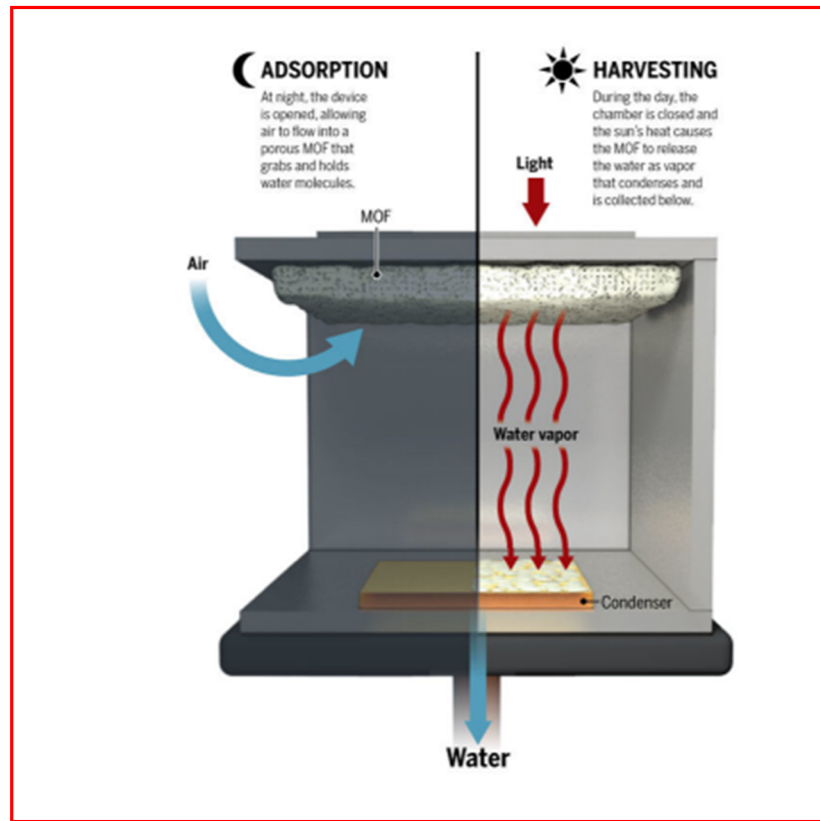

Figure 2-9: MOF typical water harvesting technology [30]

2.6.3 Extraction of Atmospheric Water Using Desiccants

a) Introduction

Various studies are being involved to obtain water from humid air depending on the weather condition and relative humidity focusing new technologies that indicated in thermodynamics to cool and condensate the incoming air. In this research the system used a salt as a desiccant to capture more moisture from air. Because, salt is abundant mineral and cheap to buy and it has high absorbing property because of its ionic compound with strong attractive forces for high polar water molecules [31].

b) Sandy Bed Techniques of Water Harvesting

Various researchers are attempting continuously to find the optimum amount of potable water from humid air around the globe. In arid to semi-arid regions, mixing a sandy layer of the ground surface with desiccant is a promising method to minimize the cost of the vapor absorption bed. A review of the literatures showed that there is an interest for absorption - regeneration method in recent years because it seems to be a feasible solution and promising for the problem of water demands especially in remote areas. Another similar study by Manoj Kumar & Avadhesh Yadav [32] in India discusses water extraction using a different desiccant technology. This technology absorbs air humidity on a solid desiccant, desorbs water to vapor and condenses vapors into water using solar energy. This study prepared a prototype, tested it, and generated water. It was found that 2.5 L/day/m^2 of fresh water could be produced by the device shown below in figure 2-10.

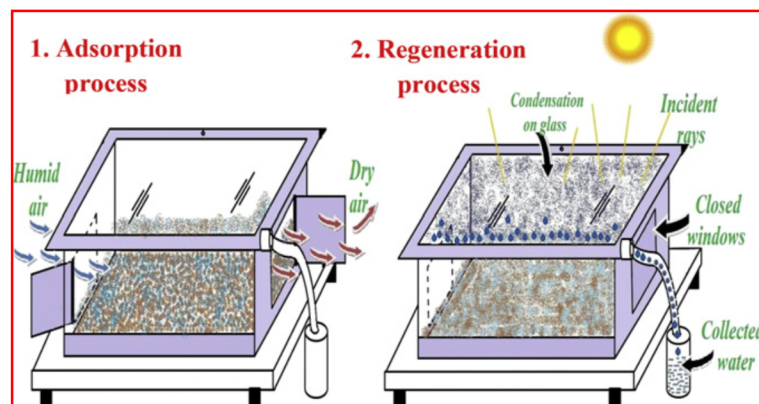

Figure 2-10: Schematic diagram for Solar Glass Desiccant box type System [32]

A study by G.E. William, M.H. Mohamed, M. Fatouh [33] used a prototype shaped as a trapezoidal prism solar collector with four sides and square base as illustrated in Figure 2-11. The height of the collector is 1800 mm and the base dimensions of the tested unit using desiccant as a host materials test rig are 1000mm x1000 mm. The water production from this test was 1.23L/day/m² at 30% concentration of CaCl₂.

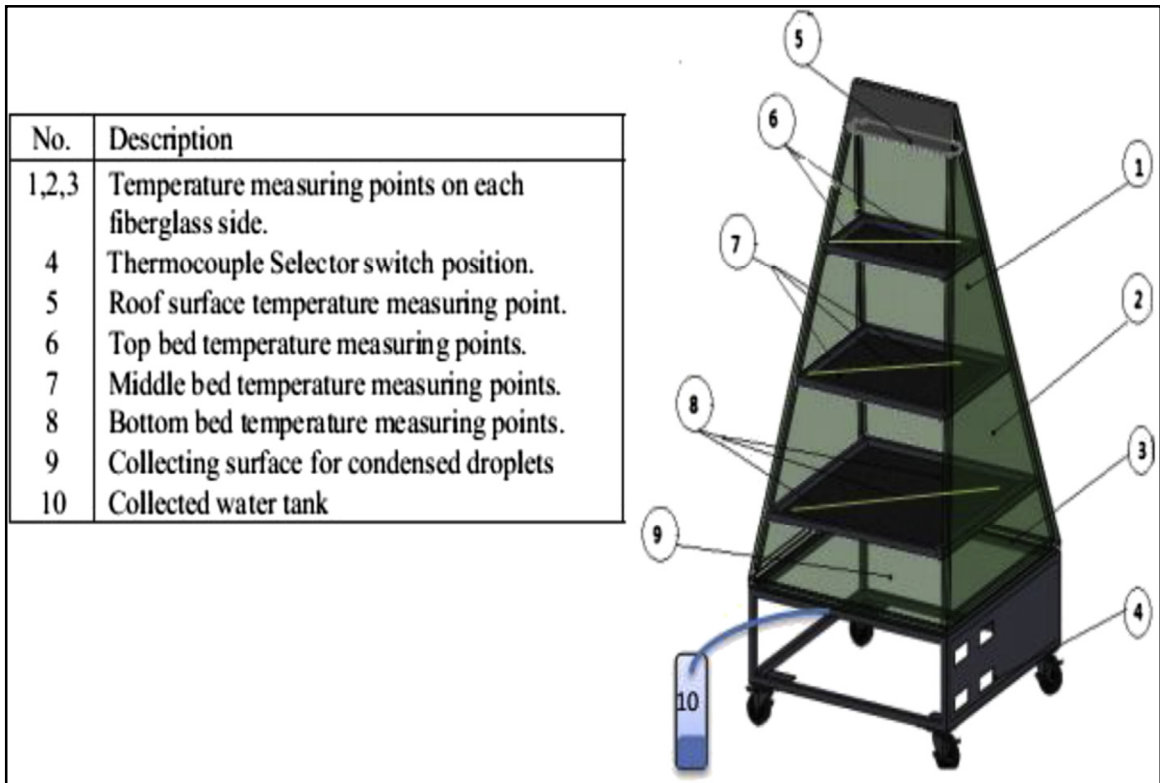

Figure 2-11: Schematic diagram of experimental test rig.

A study conducted by Manoj Kumar [34] has water production used vermiculite - saw wood as host material and CaCl₂ as a hygroscopic salt. A solar glass desiccant box type system (SGDBS) with the dimension 0.6 m x 0.6 m x 0.3 m and 0.3mx0.3m has two windows made for the adsorption process. A single glazing of 3 mm thickness has been used as a glazing which also works as a condenser during the regeneration process. The prototype used in this study is shown in Figure 2-12 below.

The sample has been prepared as follows: 1 kg of saw dust and 1 kg of vermiculite is mixed with a solution having 16%, 23%, 28%, and 33% and 38% concentration of CaCl_2 . Putting these composite desiccant material “ CaCl_2 /Vermiculite/Saw wood” in the prototype gave a maximum result recorded was 195 ml/kg/day. During the experimental day, maximum solar intensity was recorded as 972 W/m^2 .

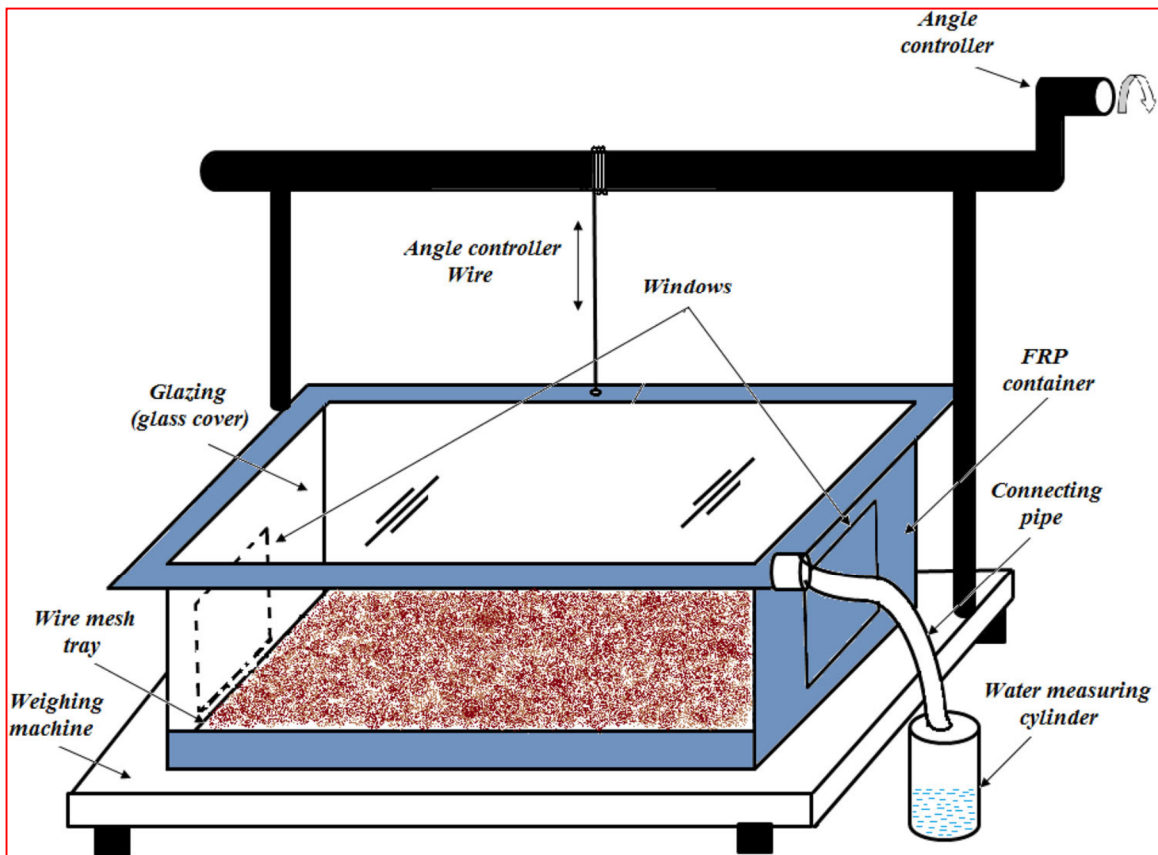

Figure 2-12: Schematic diagram for Solar Glass Desiccant box type System [34]

The review article also concluded that water generation rate depends on the solar radiation intensity, ambient conditions during the day and night, humidity ratio and concentration of the CaCl_2 solution in the sample.

Another research from Egypt has been conducted by Mohamed [33] using desiccant material (calcium chloride solution). Cloth and sand was selected as the materials. Moreover, cloth was selected as a host material due to its high liquid capacity and porosity and sand is selected as a bed with 0.05m thinness. The key parameters in the absorption process during the night time were: **relative humidity**, **ambient temperature** and **wind speed**. The wet desiccant system in this research could generate 3L/ (day /m²) of potable water in Alexandria, when the solution concentration reached 30% saturation condition at night. During day time, the evaporation and condensation happened simultaneously as shown in Figure 2-13.

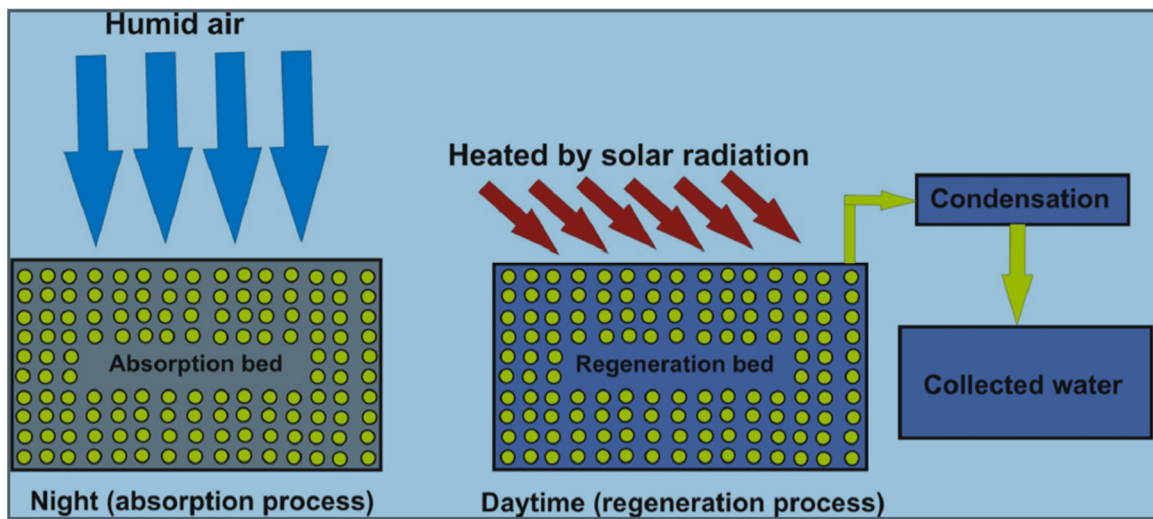

Figure 2-13: Water production from atmospheric air [33]

c) Scheffler reflector Techniques of Water from air using various Desiccants

A study of Shobhit Srivastava [35] from Indian made effective economic analysis using various desiccants. In the experiment set up test in figure 2-14 come up that silica gel was the best in cost and CaCl_2 evaluated second.

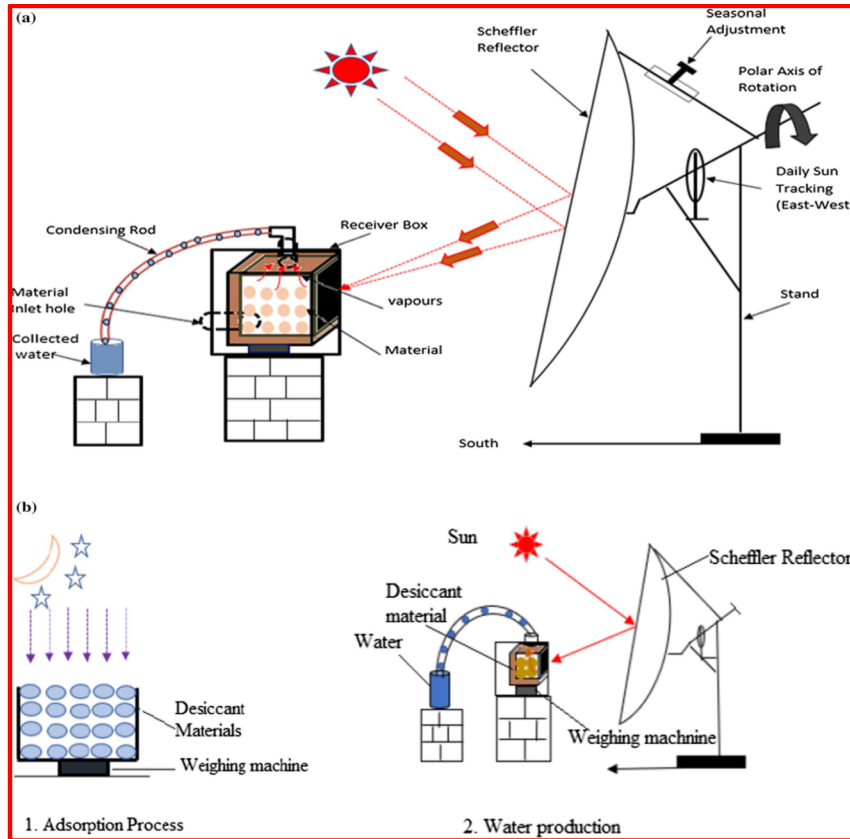

Figure 2-14: Scheffler reflector Techniques used for water harnessing [35]

Where:

- (a) Schematic diagram of experimental setup
- (b) Schematic diagram of process of water production from atmospheric air at night and day time.

2.7 Typical Cycles in Desiccant Atmospheric Water Extraction

The cycle alternates two different successive of phases as shown in Figure 2-15.

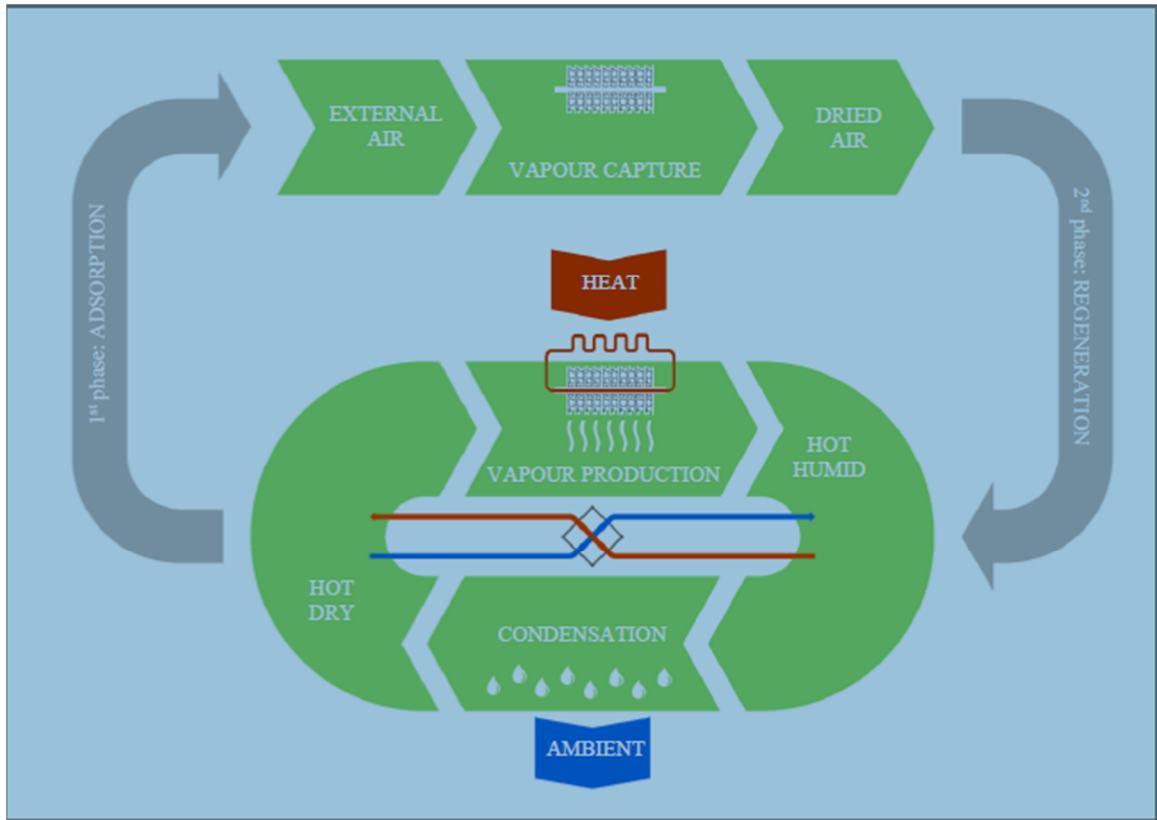

Figure 2-15: Conceptual scheme of the adsorption/desorption cycle [23]

2.8 Atmospheric Water Generator (AWG) brand in the market

2.8.1 Introduction

Atmospheric water extraction devices have a promising market in the near future.



Figure 2-16: Typical Commercial Atmospheric Water Generator [36]

2.9 Atmospheric Water Generator Brands in the Global Market

a) Sun-To-Water Device using desiccant technology.

Currently, solid desiccant technology is widely used in atmospheric water generation because it does not change phase as it collects airborne moisture during adsorption stage [30]. Since the melting point of desiccant (CaCl_2) materials is so high (773°C) desert zone's climates are not an obstacle since the system uses salt as desiccant instead of Freon to capture and condense humidity into water. Schematic drawing is representing Sun – To – Water AWG shown in figure 2-17.

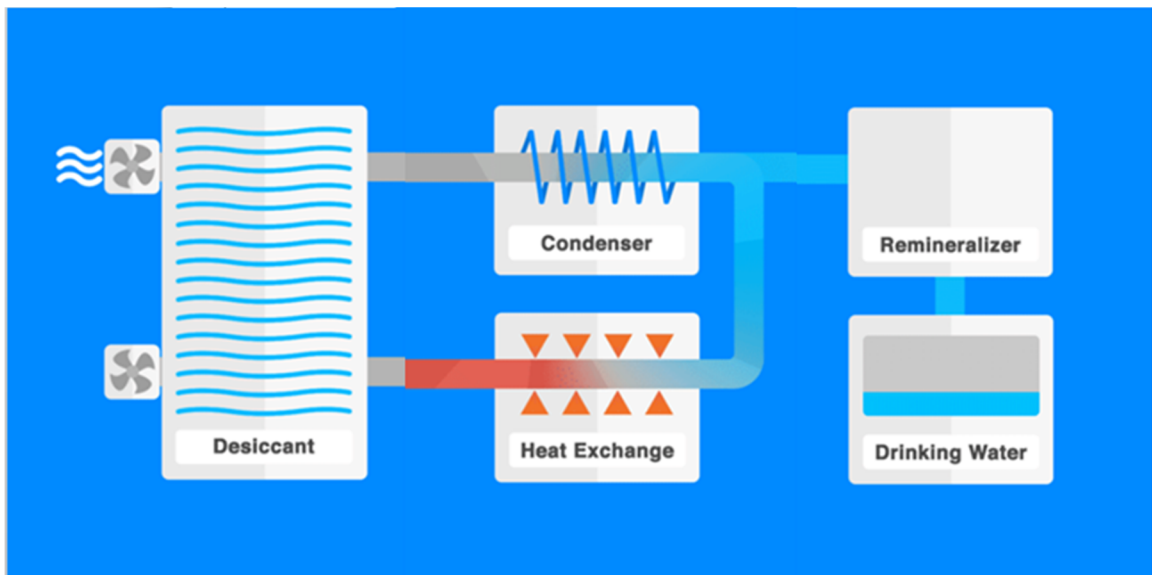

Figure 2-17: Sun-To-Water working principle [30]

b) Konia’s WATER technologies

The atmospheric water generator (AWG) of this brand is constructed to extract water from humid air. The basic operation is analogous to a refrigerator in that a compressor circulates refrigerant through an evaporator coil so that it cools the air surrounding it, lowering the air’s dew point and causing water to condense. Their control mechanism is an electronically controlled-speed fan which pushes filtered air over the coil. The generated water is then passed into a holding tank with purification and filtration systems to keep the water pure [37] . The production process is indicated in the figure 2.18 below.

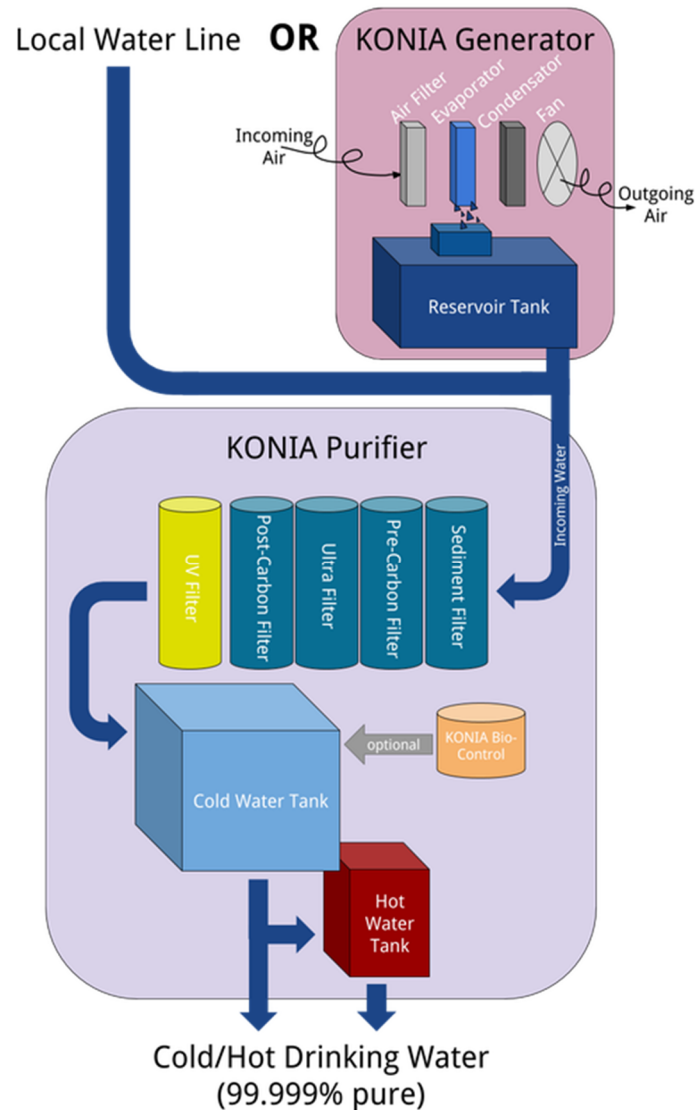

Figure 2-18: Konia Water [37]

c) SKY water Technology

Apparatus and methods for transforming water vapor into potable water by using a vapor compression refrigeration system which includes first and second cooling elements disposed in a closed loop air passage duct that provides a continuous air circulation pattern driven by a fan or similar device. Water is introduced into the circulating air and undergoes adiabatic cooling followed by two stage cooling, first at a temperature below the dew point and then at a lower temperature at or below freezing. Water is collected from the air in each step and the air is thereafter heated back up by the condensing element of the refrigeration system enabling it to absorb more water vapor at the point of introduction. The air is recirculated and processed as above to permit cyclical water recovery [38].



Figure 2-19: SKY water Technology

2.10 Growth of Atmospheric Water Generation in Ethiopia

Ethiopia is characterized by diverse climatic conditions ranging from humid to semi-arid environments. Some climates have the potential for fog formation so that it is possible to harvest liquid water from the air using nets or other materials. One attempt to collect liquid water from thin air has been done by one designer from Italy using the third class of device which is control convection in a tower structure. The Warka Water as indicated on figure 2-20 is designed to collect dew, fog and rainwater. With its beautifully designed 9 meters tall framework made out of bamboo with special water collecting fabric hanging inside, it is a great example of functional art.

The project was conceived in Ethiopia and inspired by the fact that women and children in the rural areas have to walk several hours to fetch water of questionable quality. The production capacity of this Warka tower is estimated to be at least 100liters/day of potable that water can be sustainably and hygienically collected. The construction costs approximately \$550 and can be built within a week with a 4 person's team using locally available materials [19].

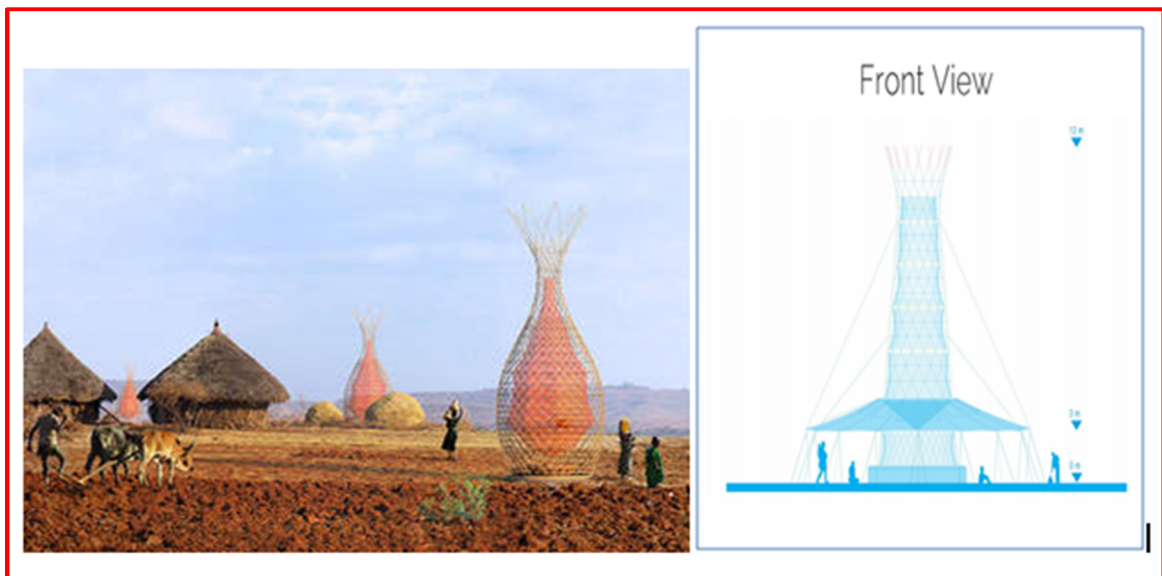

Figure 2-20: Water collector from air, Source “WarkaWater”.

On the other hand, traditional water harvesting system from rainfall has been upgraded and conducted as pilot research under Mekelle University as a teaching module in 2015 by Tsegazab Gebrelibanos Gebremedhin [39]. In this pilot work, water harvesting alternative techniques are indicated in figure 2-20 below.



Figure 2-21: Storing Water in Various Mediums

2.11 Mathematical Model

To check the feasibility of water harness from humid air by numerical analysis has been done base on reputable literatures [34]:

1. Adsorption rate of composite desiccant material:

$$G_A = M_{ws} \frac{d_w}{dt} \dots\dots\dots [1]$$

where, G_A is Adsorption rate (kg/h), M_{ws} is weight of desiccant on wet basis (kg).

2. The calculation for the amount of salt required to prepare a solution is given by:

$$X = \frac{M_s}{M_{sol}} \dots\dots\dots [2]$$

and;

$$M_{sol} = M_s + M_w \dots\dots\dots [3]$$

where, M_s is the mass of salt, M_w is the mass of distilled water, M_{sol} is mass of solution.

3. Water productivity rate highly depends on:

- solar radiation intensity,
- ambient conditions during the day and night,
- Air humidity and
- concentration of the $CaCl_2$

4. The efficiency of the system can be calculated as:

$$\eta = \frac{M_w L}{(\tau\alpha) H A} \dots\dots\dots [4]$$

Here, M_w is the mass of water(kg), L is the latent heat of water at an average bed temperature (J/kg), H is the solar intensity in Wm^{-2} , A is the area of glass cover (m^2), $(\tau\alpha)$ is the transmissivity absorptivity product.

5. Energy Balance of Solar Collector

I used lecture note from Lulea University of Technology organized by Mohammad Kharseh (E-mail:m.Kharseh@gmail.com) [40].Some related formula and pictures are taken from this lecture note for illustration indicated below.

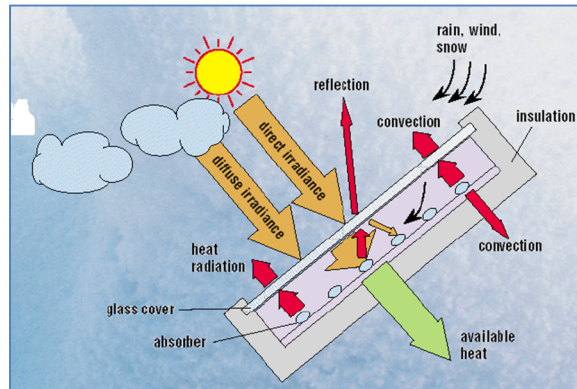

Figure 2-22: Flat plate Solar Collector

6. Useful Heat Gained By the Collector

$$q_u = S \cdot A_p - q_1 \dots \dots \dots [5]$$

where:

q_u = Useful Heat Gained By The Collector

S = Solar Energy absorbed in absorber

A_p = Area of the absorber plates

q_1 = Heat lost from the collector

7. Heat Losses from Collector

$$q_1 = U_1 \cdot A_p \cdot (T_{pm} - T_a) \dots \dots \dots [6]$$

where:

U_1 = The overall heat loss coefficient, U_1 [W/m²,K]

T_{pm} = Mean temperature of absorber plates

T_a = Ambient air temperature

As solar radiation continuously heat the bed surface it becomes warmer than the ambient air then heat losses happened from the cover, sides and bottom of the plate as:

- the cover (top), [W] : $q_t = U_t \cdot A_p \cdot (T_{pm} - T_a)$
- the bottom, [W] : $q_b = U_b \cdot A_p \cdot (T_{pm} - T_a)$
- the sides, [W] : $q_s = U_s \cdot A_p \cdot (T_{pm} - T_a)$

8. Collector Efficiency

$$\eta = \frac{\text{Usefull gain}}{\text{Available Energy}} = \frac{\text{Heat gained by the air(watt)}}{\text{Solar incident radiation(watt)}}$$

$$\eta = \frac{mC_p(T_{out}-T_{in})}{AI} \dots\dots\dots [6]$$

where $\eta(\%)$ is collector efficiency, $m(\text{kgs}^{-1})$ is the mass flow rate of the fluid flowing through the collector; $C_p(\text{Jkg}^{-1}\text{k}^{-1})$ is the specific heat at constant pressure; $T_{in}(\text{k})$ is the inlet and $T_{out}(\text{k})$ outlet fluid temperatures, respectively. $A(\text{m}^2)$ is surface area of the collector and $I(\text{Wm}^{-2})$ is intensity of solar radiation.

2.12 Critical observations from journal papers

- 1) Warka Water Tower project [19] basically designed to collect and harvest potable water where there is high amount of humidity or frequently rainy highland area of Ethiopia. This project has its own drawbacks from dust and debris blow into the net and this project is not totally applicable in semi-arid part of Ethiopia because of relatively low humidity.
- 2) From the paper “Composite desiccant material “CaCl₂/Vermiculite/Saw wood”: a new material for fresh water production from atmospheric air” [34], I observed that a novel composite desiccant mixed with a solution having 9-37% concentration of CaCl₂. Adsorption process has been performed due to vapor pressure difference between the surface of composite desiccant material and atmospheric air and possess a lot of potential theoretically but when the researchers made a prototype and tested it the results were not satisfactory. The device could produce only 195 ml/kg/day. After studying the paper “Solar-based atmospheric water generator utilization of a fresh water recovery: A numerical study” from Kabeel [41] has shown in best way. So, this type of Atmospheric Water Generators systems could be a solution for semi-desert area.

2.13 Objectives and scope of present work

It is obvious that there are many AWG products that are available in the market which use refrigerator system technology. They are not portable and since they use a compressor they have heavy electricity demand and are not eco-friendly. Since we wanted to make from a local material device hence we thought of using some other method to achieve our goal.

1. After going through all the available options we finally concluded that we would use a solid desiccant to create the Atmospheric Water Generator. In the paper “Solar-based atmospheric water generator utilization of a fresh water recovery: A numerical study” Kabeela and others had already done a numerical study of the efficacy of a solid desiccant bed device. After getting the results we collected the metrological data for different semi-arid cities of Ethiopia: Babile, Awash 40 and Yabello whether our designed prototype would function or not.

2.14 Summarized Literatures as a bench mark

The idea of collecting humidity from thin air is actually not new; there are several trials which were done in order to get the water from the air humidity. For comparison and to measure the efficiency of the applied systems in the table 2-3 below, potable water WHO standard for one person per day is 2.5L/capita/day as identified by Sri Suryaningsih and Otong Nurhilal [42] . However, the attempts to get water from thin air in the most arid areas in the world did not yet stop. Among these attempts are:

Table 2-3: A comparative summary of Studies conducted

No	Author	Design Type: Bed Desiccant	output :L/d	Places
1	Manoj Kumar [34]	Wet Desiccant	0.195L/kg/day	India
2	Hamed et al. [43]	Solar Powered desiccant system Sand box :0.5m*1.0m*0.3m RH <40% & TD -4 to 15 °C	1liter per m ²	climatic conditions of Taif, Saudi Arabia
		Sandy bed impregnated with calcium chloride	Liter per m ² of pure water	Taif,KSA
3	Kabeel [44]	Sandy bed impregnated with 30% concentration calcium chloride Surface area of 0.5m ²	1.2 l fresh water per square meter of glass cover per day in the climatic conditions of Tanta city, Egypt which is mostly humid	Tanta city, Egypt
4	M. KUMAR ET AL. [45]	Different Composite desiccant material using solar glass desiccant box type system (SGDBS) with a collector area of 0.36m ² : Box size: 0.6m×0.6m×0.3 m Two windows of size 0.3m×0.3m A glass having 3mm thickness and single glass height of the glass from the desiccant bed to be 0.22 m inclination angle of 30° CaCl ₂ : concentration 37% is constant. The maximum solar intensity during the day: 792W/m ² .		India
		vermiculite/saw- wood/ CaCl ₂	0.13L/day/Kg	
		jute/ CaCl ₂	0.11L/day/Kg	
		burnt-clay/CaCl ₂	0.06L/day/Kg	

Chapter 3 : Materials and Methods

3.1 Introduction

Chapter three discusses design such as estimation of load and load profile, estimation of available solar radiation and design of glazing system, including area of air ventilation window, and selection of other components.

Design focus area was in Borena zone at Yabello district, Oromia, Ethiopia which is found in southern Ethiopia. The town is at latitude 4.88333N and longitude 38.08333E. The climate is semi-arid. Meteorological data of Yabello district was taken from National Meteorological Services Agency of Ethiopia. But, test was conducted in Adama, Ethiopia.

3.2 Study location and Climatic data

3.2.1 Location and Accessibility

The study area selected for this project is Yabello in Borena zone of, Oromia National Regional state, South Western Ethiopia (Figure3-1). It is located a distance of 575 km south of Addis Ababa. Geographically it is bounded between 4° 53'N and 38° 5'E. The average elevation is 1729m. The study area can be accessed from Addis Ababa through Hawasa -Dilla - Bula Hora - Yabello by asphalted road on the Ethio-Kenya highway.

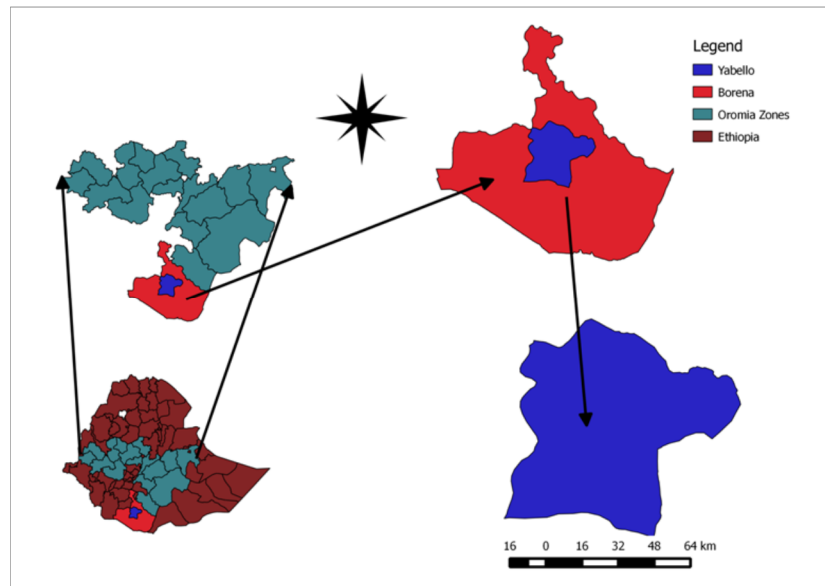

Figure 3-1: Map of Study Area from GPS [46]

3.2.2 Climate

The climate data for the study area was obtained from local and international climate centers. According to assessments made by three scholars : Dandesa T, Korecha D, Nigatu L. and Cheneka BR [47] the Borena area is classified as arid and semi-arid with mean average annual rainfall 238 mm to 896 mm. Mean daily air temperatures range between 19°C and 26°C. In a year the average rainfall in Yabello is 588mm. Researchers: Massimiliano Fazzini, Paolo Billi, and Carlo Bisci from University of Ferrara and University of Camerino respectively [48] explained that the southern part of Ethiopia is among the most humid regions in the African continent (the great equatorial lakes region), The National Meteorological Agency of Ethiopia (NMA) monthly average sunshine hour and wind speed data is indicated in table 3-1.

Because of the favorable temperature, humid air, and the potential of solar energy available, this area is suitable for harvesting atmospheric water and turning in to potable water. Hence, Yabello area was selected for potable water harvesting study. Based on the interpolated data lowest solar radiation corresponding to relative humidity values among the data, therefore **July** was selected as the design month.

Table 3-1: Yabello (Latitude 6°83’N, longitude 38°5’E, 1729m a.s.l) 2014-2016

Average	Jan	Feb	Mar	Apr	May	Jun	Jul	Aug	Sep	Oct	Nov	Dec
Solar radiation(H/day)	10	11	6.9	5.9	5.7	4.8	3.7	4.8	6.2	5.3	6.8	8.8
Temp.(°C) Max.	29	29.7	27.8	34	25	25	24	25	26	26	25	27
Temp.(°C) Min.	13	12	16	16	16	15	14	14	14	16	15	13
Relative humidity (%), RH	47	49	50	67	75	67	65	63	67	74	50	55
Wind speed at 2m height (m/s)	1.1	1.5	2.1	0.96	0.86	0.68	0.95	1.14	1.24	1.17	0.85	0.82
Precipitation (mm)	0.051 613	0.808 065	1.702 151	5.192 473	2.2516 13	1.168 817	0.012 903	2.053 226	0.2763 44	3.0268 82	1.787 097	0.825 806
Wet Bulb Temp. (°C)	13. 9	15.1	15.1	17.1	17.5	16.1	15.2	15.3	16.2	17.1	16.4	-
Dew point Temperature (°C) calculated, $td \approx t - \left(\frac{100 - RH}{5} \right)$	12. 3	13.5	13.5	15.3	15.98	14.2	13.1	13.2	14.3	15.56	-	-

This data in table 3-1 was taken from National Meteorological Agency of Ethiopia

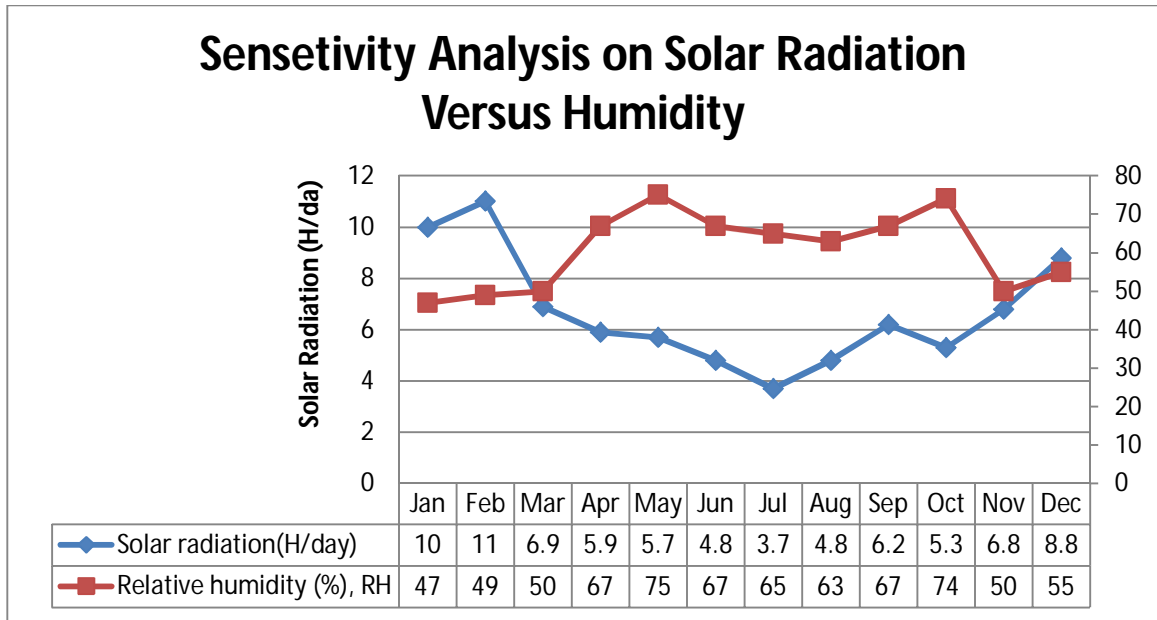

Figure 3-2: Sunshine & Relative Humidity to determine design month (interpolated)

3.2.3 Prototype test location and Climatic data

Based on certain climate similarity to Yabello, the test center was selected for this project Adama Wind farm area (Fig 3-3). Adama is located directly west of Ethiopia's Great Rift Valley, and approximately 90 kilometers southeast of Addis Ababa. Geographically it is bounded between +8.55 (8°33'00"N) and +39.27 (39°16'12"E).The average elevation is **1,712 m**.



Figure 3-3: Wind Farm area

Table 3-2: Adama (Latitude: 8.5263°N, longitude: 39.2583°E, 1712 m) 1995 – 2007 [49] & [50].

Average	Jan	Feb	Mar	April	May	Jun	July	Aug	Sep	Oct	Nov	Dec
Solar radiation(H/day)	9.6	9.1	8.1	8.1	9.0	8.3	6.5	7.2	7.4	8.3	9.7	9.8
Temp.(°C) Max.	26.8	28.8	29.4	29.8	28.2	27. 0	23.7	25.7	27.2	27. 5	26.8	25.8
Temp.(°C) Min.	13.1	14.4	13.8	14.4	15.2	16. 0	14.8	16.1	15.3	14. 0	13.3	12.3
Relative humidity (%)	69	65	71	73	70	72	81	81	81	74	65	67
Wind speed at 2 m height (m/s)	2.5	2.6	2.1	2.0	2.0	2.9	3.0	2.5	1.8	2.2	2.7	2.7
Precipitation (mm)	20		32	80	96	56	112	245	269	117	40	9
Dew point (°C) calculated	17.3	17.8	16.4	27	20.3	18. 4	17	17.5	19.4	21	13.8	17.2

3.1 Data Source and Methods of Collection

3.1.1 Data and data sources

The first thing to do for the desired study is evaluating the resources that are available by searching the primary and secondary data from National Weather Station agency and Ethiopian Energy Authority, thesis, publications, and books.

3.1.2 Method of data collection

The methods employed to achieve the objectives of the research are:

- **Literature Reviewing:** Searching for thesis, publications, newspapers, books, scientific journals, etc. on different web sites which are helpful for meeting the general objective and the specific objective as well.
- **Prototype Design:** A prototype of the Atmospheric water generating (AWG) was designed with some specified dimensions.
- **Manufacturing prototype:** After the design process is completed, the prototype is manufactured from simple material like from packing carton. After reviewing the fake prototype from simple packing materials, based on the actual design parameters and design materials, the prototype of the AWG was manufactured by own expense in commercial shop.

- **Experimental Investigation:** After the prototype is filled with Ash (insulating material), sand and CaCl₂ mixtures and assembled, experimental investigation were conducted by recording sunshine hours and the amount of water generated per day per each attached plastic bottle fitted to AWG.
- **Analysis and Interpreting the Result:** The test results are compiled and confirm that the device is capable of water generating from humid air using sunshine and composite material packed into the device.

3.2 Design and Manufacturing of the Prototype

3.2.1 Determining the Volume of Prototype by output target

Assume linear dimension of solar box is:

- ✓ Length: **1meter**
- ✓ Width: **1meter**
- ✓ Air gap height from desiccant material to be 0.2-0.3 = **0.22meter**

$$\begin{aligned} \text{Volume of air in the prototype} &= \frac{1}{2} \times L \times W \times H \\ &= \frac{1}{2} \times 1 \times 1 \times 0.22 \\ &= \underline{\underline{0.11\text{m}^3}} \end{aligned}$$

The space likely occupied by the humid air in the prototype is 0.11m³ (110liters) by volume. Thus multiplying humidity ratio by **110** gives the maximum amount of water (in litres) that is present in 0.11m³ of humid air.

Ambient temperature (T_a) of 32°C and relative humidity (i.e amount of water in the air) of 60% is taken from the above table 3-2.

Saturation Pressure of water vapor (P_s) at 32°C is obtained from steam table as 0.04759 bar.

$$RH = 100 * \frac{\text{partial pressure of water}}{\text{vapor pressure of water}}$$

$$\begin{aligned} \text{Hence, partial pressure of water vapor (P}_w) &= \frac{RH}{100} * P_s \\ &= \frac{60}{100} * 0.04759 \end{aligned}$$

$$P_w = \underline{\underline{0.028554 \text{ bar or } 2,855.4\text{N/m}^2}}$$

$$\text{Humidity ratio, } \phi = 0.622 * \frac{P_w}{P_a - P_w}$$

; (Where Pa is the atmospheric pressure i.e. Pa=1.01325 bar)

$$= 0.622 * \frac{0.028554}{1.01325 - 0.028554}$$

$$= 0.622 * \frac{0.028554}{0.984696}$$

$$= 0.0180366204$$

Thus the nominal amount of water (in litres) present in 110liters of atmospheric air

= Humidity ratio * 110liters

= 0.0180366204*110

= **1.984** liters is expected per day. for 50% device efficiency

Target water production is about **1L/day/m²**.

The air contains water vapor, the amount of mass of water vapor in the air per unit volume depending on the temperature and relative humidity. It is given by [51]:

Yabello Weather data:

Relative Humidity (RH) = 49 - 80% from the range **60%** is considered

Dry-bulb Temperature/Ambient Temperature (DBT) = 15–32°C

Elevation (E_L) = 1729m.

The mass of water vapor in the air per unit volume depends on the temperature and relative humidity. It is given by [51]:

$$X = \left[\frac{0.622e}{p_{sta} - e} \right] * 1000 \dots\dots\dots [1]$$

where: X is concentration of mass (g/m³),

$$T_{dew} = 237.3 \left[\frac{\ln\left(\frac{RH}{100}\right) + \frac{T}{237.3+T}}{17.27} \right] \div 1 - \left[\frac{\ln\left(\frac{RH}{100}\right) + \frac{T}{237.3+T}}{17.27} \right] \dots\dots\dots [2]$$

$$\begin{aligned} &= 237.3 \left[\frac{\ln\left(\frac{60}{100}\right) + \frac{32}{237.3+32}}{17.27} \right] \div 1 - \left[\frac{\ln\left(\frac{60}{100}\right) + \frac{32}{237.3+32}}{17.27} \right] \\ &= 237.3 \left[\frac{-0.10536}{17.27} + \frac{32}{269.3} \right] \div 1 - \left[\frac{-0.10536}{17.27} + \frac{32}{269.3} \right] \\ &= 237.3 [-0.0061 + 0.10491] \div 1 - [-0.0061 + 0.11883] \\ &= 237.3 [0.11273] \div 1 - 0.11273 \\ &= 237.3 [0.11273] \div 0.88727 \end{aligned}$$

$$T_{dew} = \underline{\underline{23.25386}} \text{ } ^\circ\text{C}$$

Where:

- T_{dew} is dew point temperature ($^\circ\text{C}$) and T is ambient temperature ($^\circ\text{C}$)
- RH is relative humidity (%)
- E_L is elevation above the sea level (m),
- e is actual vapor pressure (mBar),
- P_{sta} is station pressure (mBar),

$$e = 0.6108 \exp^{\left[\frac{17.27T_{dew}}{T_{dew} + 237.3} \right]} \dots\dots\dots [3]$$

$$\begin{aligned} &= 0.6108 \exp^{\left[\frac{17.27 * 23.3}{23.3 + 237.3} \right]} \\ &= 0.6108 \exp^{\left[\frac{402.391}{260.6} \right]} \\ &= 0.6108 e^{1.544} \\ &e = \underline{\underline{2.856804}} \end{aligned}$$

Saturation Pressure of water vapor (Ps) at 32°C and 1729m elevation is:

$$P_s = 10132.5 \times \left[\frac{293 - 0.0065EL}{293} \right]^{5.26} \dots\dots\dots [4]$$

$$= 10132.5 \times \left[\frac{293 - 0.0065 \times 1729}{293} \right]^{5.26}$$

$$= 10132.5 \times \left[\frac{293 - 11.24}{293} \right]^{5.26}$$

$$= 10132.5 \times \left[\frac{281.8}{293} \right]^{5.26}$$

$$= 10132.5 \times [0.96]^{5.26}$$

$$= 10132.5 \times 0.8141$$

$$P_s = \underline{\underline{8.24887}} \text{ bar}$$

The amount of water in **1 m³** of air may be computed by :

Table 3-3: Max. Partial pressure of water vapor in atmosphere [52]

T,°C	-10	0	10	20	30	40	50	60	70	80	90	100
P,kPa	0.287	0.611	1.22	2.33	4.27	7.33	12.3	19.9	30.9	49.7	70.1	101

Or;

$$X = 0.00625[P_s (T_2) RH - P_s (T_1)] \dots\dots\dots [5]$$

$$X = 0.00625[4.27 \times 0.6 - 2.33]$$

$$= 0.00625[2.562 - 2.33]$$

$$= 0.00625[0.232]$$

X = **1.45L.....** Gross amount of water can be produced from this prototype per day per m² of the collector area.

3.2.2 Determining Energy requirement for water harvesting from air

Solar irradiance is a measure of how much solar power obtained at certain location. Factors affecting and various the amount of solar energy is the position of sun in the sky and the weather. On the other hand solar insolation is a measure of a solar irradiance over of period of time-typically over the period of a single day. It is possible to calculate solar irradiance on ‘[http://www.solarelectricityhandbook.com/solar irradiance](http://www.solarelectricityhandbook.com/solar_irradiance)’ for Yabello and Adama as follow on the screenshot figure.

Table 3-4: Solar Irradiance Figures on Adama/Nazareth measure in kWh/m²/day onto a horizontal surface [53]

<i>Direction /month</i>	<i>Jan</i>	<i>Feb</i>	<i>Mar</i>	<i>Apr</i>	<i>May</i>	<i>Jun</i>	<i>Jul</i>	<i>Aug</i>	<i>Sep</i>	<i>Oct</i>	<i>Nov</i>	<i>Dec</i>
Facing to all direction	6	6.5	6.44	6.22	6.25	5.7	5.1	5.3	5.8	6.24	6.21	6.02

Some findings indicated that to produce one liter of water, on average **2kWh** of energy is required [54].

- ✓ Exposed area of solar glass of the prototype at one side:
= 0.6m*1.17m = **0.702m²**
- ✓ Sunshine hour (H/day) at Adama = **8-9h**
- ✓ Solar irradiance in kWh/m²/day onto a horizontal surface = 6

Therefore total solar irradiance could absorb by the prototype:

$$= 6*0.702$$

$$= **4.212 kWh/m²/day**$$

The project report by Fabio Struckmann [55] to analysis efficiency of a flat-plate solar collector as shown in the below found out 45% is useful.

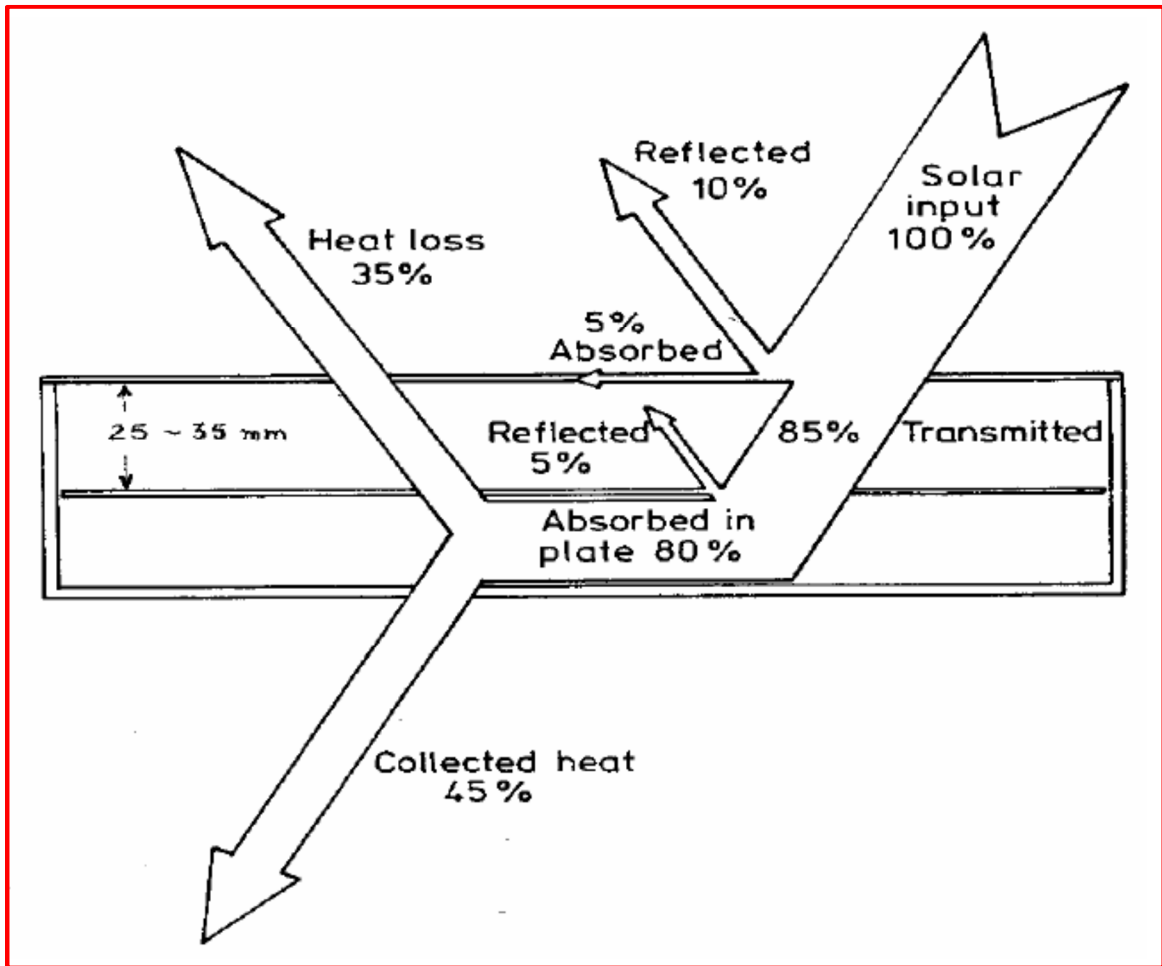

Figure 3-4: Heat flow through a Flat Plate solar collector [55]

Depending the finding by Fabio Struckmann the prototype absorbed 45%:

$4.212 \text{ kWh/m}^2/\text{day} * 0.45 = 1.9 \text{ kWh/m}^2/\text{day}$; heat is collected per the prototype.

Therefore using solar irradiance in Adama per this prototype will be $1.9/2 = 0.9$ liters will be generated.

3.2.3 Design procedure

The size of the device is determined as a function of the vapor condensation area needed per kilogram of sand and desiccant. The dew temperature is established as a function of the minimum limit of temperature the desiccant mixture.

From the climatic data (meteorological station, Yabello, southern Ethiopia, in 2016) the mean average day temperature in April is 26°C and RH is 68 %. From the psychometric chart the humidity ratio is 0.0018kg H₂O/kg dry air.

The underlined assumption of the design is:

- All physical properties are constants through the operation time.
- All evaporated water should be condensed at the glass cover.
- Completely closed system during day time operation (regeneration process).
- Condensation and evaporation processes are occurred simultaneously.

3.2.4 Selection of Input Material for Prototype

a) Selection of Calcium chloride as Solid Desiccant

It is preferred to select calcium chloride because of its amazing capacity in absorbing moisture from air. At a relative humidity (RH) of only 50%, calcium chloride's moisture absorption is 150% its weight in water. Its absorption increases exponentially as RH rises, to 600% at 85%RH whereas Silica gel absorbs poorly at low RH, trapping only 25% of its weight at 50% humidity. Unlike calcium chloride's exponential curve, silica gel's absorption is more linear only 36% at 85%RH.

Table 3-5: Properties of CaCl₂ Hydrates [56]

<i>Property</i>	<i>CaCl₂6H₂O</i>	<i>CaCl₂4H₂O</i>	<i>CaCl₂2H₂O</i>	<i>CaCl₂H₂O</i>	<i>CaCl₂</i>
Composition (%CaCl ₂)	50.66	60.63	75.49	86.03	100
Molecular Weight	219.09	183.05	147.02	129	110.99
Melting point (°C)	29.9	45.3	176	187	773
Density at 25°C,g/cm ²	1.71	1.83	1.85	2.24	2.16
Heat of Fusion (Cal/g)	50	39	21	32	61.5
Heat of Solution in H ₂ O(Cal/g)	17.2	-14.2	.72.8	-96.8	-176.2
Heat of Formation at 25°C,kcal/mole	-623.3	-480.3	-335.58	-265.49	-190.10
Heat of Capacity at 25°C, cal/g°C	0.34	0.32	0.28	0.20	0.16

b) Selection of River Sand as a host material

In this prototype river sand and Abujed clothe was compared as a host material. Using river sand as a host bed, river sand has a high average thermal capacity $98 \text{ kJ}/(\text{m}^2, ^\circ\text{C})$, whereas the cloth has relatively low average thermal capacity $41 \text{ kJ}/(\text{m}^2, ^\circ\text{C})$. Hence, to save energy and as a reason that sand is easily available was selected.

Furthermore, the river sand and calcium chloride (composite materials) to absorb incident solar radiation to gain heat ultimately converts radiation into thermal energy. Then aid to make water evaporation from the sand when dry bulb temperature reaches 100°C . River sand was selected because of its cost effective, cheap and readily available near the user. As per experiment conducted by 'R. Lalitha Priya, Salim Subi, B. Vaishnu and K. R. M. Vijaya Chandrakala' [57] Sand can function as thermal collector, heat transfer medium as well as thermal storage.

According to laboratory test by Differential Scanning Calorimeter (DSC) of 'R. Lalitha Priya, Salim Subi, B. Vaishnu and K. R. M. Vijaya Chandrakala' [57] the average heat capacity of the river sand sample was $1041 \text{ J}/\text{kg}/\text{K}$ which makes it a suitable option for thermal energy storage.

c) Selection of Wood As thermal Insulator

As we learnt from our families, they keep the red hot fire on wood covering in ash because they know that ash is used as insulator so that it prevent heat loss and it does not allow cold air from the surrounding, too. From this practical point of view, Ash is selected because of this material property with very low thermal conductivity. During direct sun shine heating the sand composite materials thermal development should not be lost through bottom and side of the device. To minimize heat lost from the bottom and sides of the casing wood ash fills the space.

3.2.5 Determination of geometry of the prototype

According to study of Wael M. El-Maghlany [58] as indicated in figure 3-5, the total energy is the summation of the collected energy by the two surfaces represents the double slope solar still surface area. By the same principles it is possible to consider solar glass on the prototype.

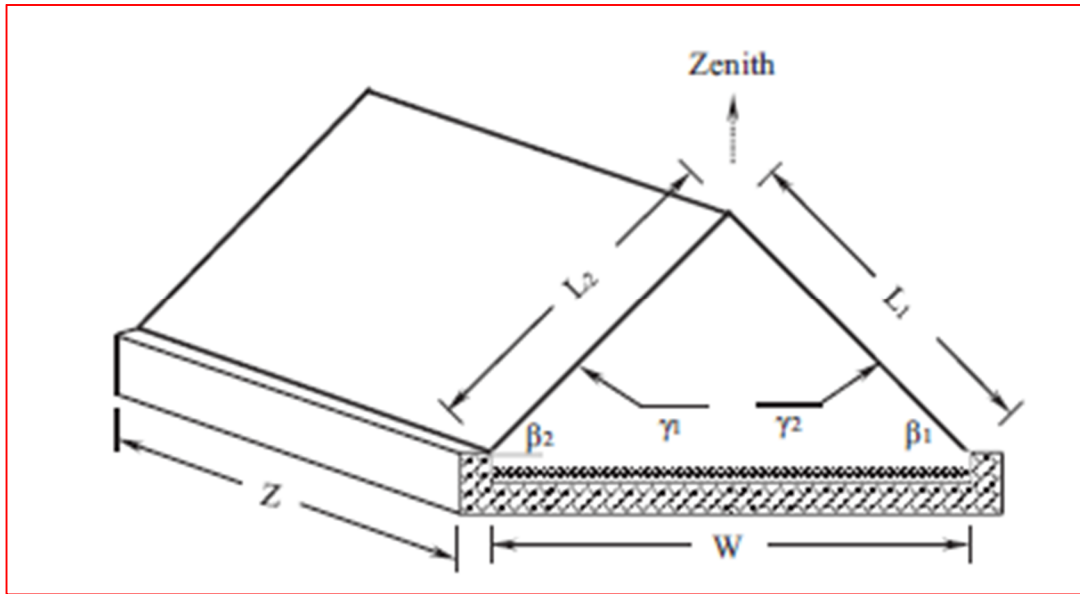

Figure 3-5: Flat surface double slope solar still

Where: Glass cover inclination angles ($\beta_1 = \beta_2$), The double glass cover has two azimuth angles ($\gamma_1 = \gamma_2$).

Glass covers total length (L) as:

$$L_1 + L_2 = L \quad \dots\dots\dots [1]$$

$$L_1 \cos\beta_1 + L_2 \cos\beta_2 = W \dots\dots\dots [2]$$

$$\text{Surface Area, } A = L * Z \quad \dots\dots\dots [3]$$

The total radiation absorbed on the tilted surfaces per unit surface area ($L * Z$) is the sum of the average beam and diffuse radiations as following:

$$E_G = G_b + G_d \dots\dots\dots [4]$$

Where:

- ✓ E_G is total radiation absorbed on the tilted surfaces per unit surface area,
- ✓ G_b is the diffuse radiation per unit area ($L * Z$) for the inclined flat surfaces at inclination angles ($\beta_1 = \beta_2$)
- ✓ G_d is beam radiation per unit area ($L * Z$) for the inclined flat surfaces at inclination angles ($\beta_1 = \beta_1$)

The total solar energy received (HG) per unit area ($L * Z$) for a total number of days ($n=365$) will be obtained:

$$HG = \int_1^{365} \int_{\Omega_{sunrise}}^{\Omega_{sunset}} E_{gd} \Omega \quad \dots\dots\dots [5]$$

Total transmitted energy through the still surface at $\beta_1 = \beta_2$ for different latitude angles.

Table 3-6: Selection of Inclination Angle of Solar Glass [58]

<i>Latitude angle (ϕ)</i>	<i>(24°)</i>		<i>(27.2°)</i>		<i>(30°)</i>		<i>(31.2°)</i>	
$\beta_1 = \beta_2$	10°	24°	10°	27.2°	10°	30°	10°	31.2°
HG (GJ/m ² /year)	6.3	5.88	6.08	5.56	5.87	5.26	5.77	5.14

Table 3-7: Sizing of the Prototype

<i>No</i>	<i>Items</i>	<i>Symbol</i>	<i>Value</i>
1	Proto type Atmospheric Water Generator Size (Double Triangular shape)	-	(1 *1*0.233) m ³
2	Fixed inclination angle	θ	30 ⁰
3	Bed Area	A _b	1m ²
4	Bed Thickness (Sand thickness in sand box)	δ_b	0.15m
5	Air Gap thickness (Glass cover gap from host material)	Δy	0.22m

3.2.6 Selection of clear Glass as a solar Collector

Glazing material is selected for solar glass cover as a result of [59].It performs three major functions in particular:

- ✓ to minimize convective and radiant heat loss from absorber,
- ✓ to transmit the incident solar radiation to the absorber plate with minimum loss,
- ✓ to protect the absorber plate from outside environment,
- ✓ Other important characteristics of glazing materials are reflection (r), absorption (α), and transmission (τ).
- ✓ Glass material has highly desirable property of transmitting as much as 90% of the incoming short-wave radiation, while virtually none of the long wave radiation emitted by the absorber plate can escape outwards by transmission.

Experiment tested for glass thickness effect of glass thickness on performance of flat plate solar collectors for fruits drying has shown that there were significant differences

between the means of collector efficiency with different glass thicknesses as in figure3-6. On this project 4mm thickness clear glass is used.

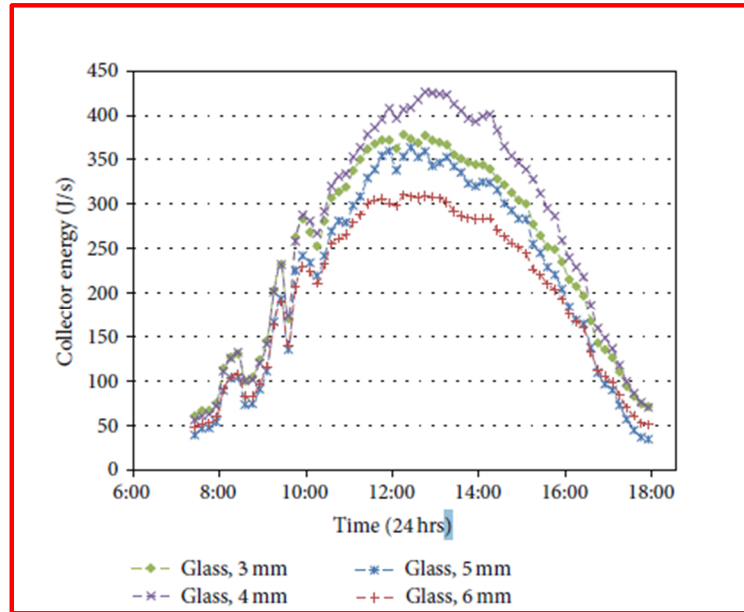

Figure 3-6: Energy profile of collectors with different glass thickness [59]

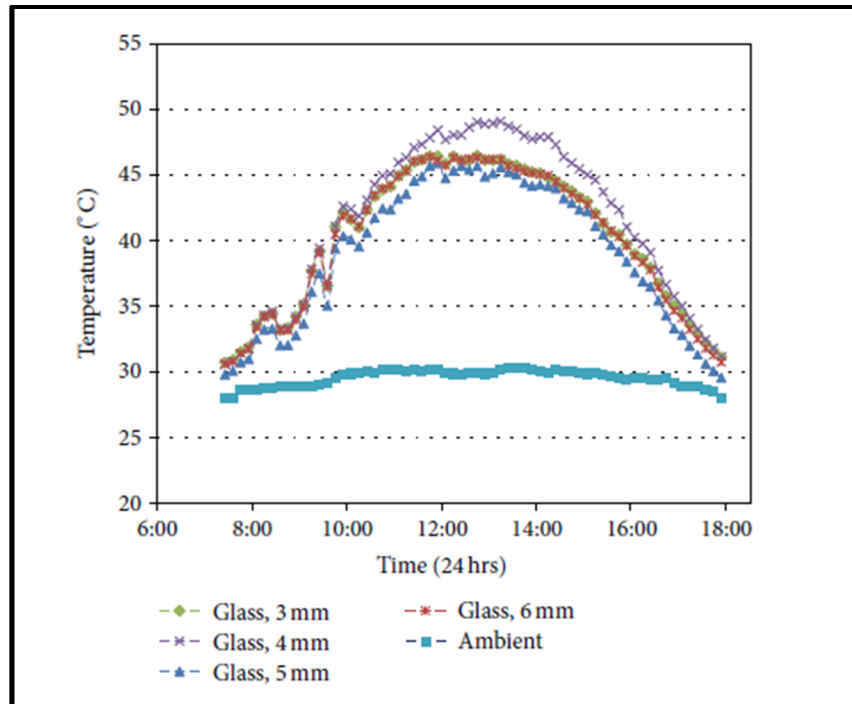

Figure 3-7: Temperature profiles of collector with different glass thicknesses [59]

Increasing the thickness of the glass panel from 3 mm to 4 mm the heat flux through the glass decreases slightly. The increase of the absorption of the thermal radiation within the glass material and then this accumulated heat is reradiated into the inside space.

Table 3-8: Thermo physical properties of glass [60]

Thermal conductivity λ [W/m·K]	1.38
Density ρ_g [Kg/m ³]	2190
Specific heat c_p [kJ/kg·K]	0.74

Table 3-9: Design parameters [33].

No	Design parameter	Symbol	Value
1	Desiccant ($M_d=1.8\text{kg}$)	CaCl_2	30-40%
2	Glass cover transmissivity (single glazing)	τ_g	0.87
3	Glass specific heat	C_g	$1640 * 10^3 \text{ J}/(\text{m}^3\text{°C})$
4	Water specific heat	C_w	$4.18 * 10^3 \text{ J}/(\text{kg}\text{°C})$
5	Calcium chloride specific heat	C_d	$3.06 * 10^3 \text{ J}/(\text{kg}\text{°C})$
6	Air gap conductivity	K_a	$0.03 \text{ W}/(\text{m}\text{°C})$
7	Shape factor between glass and sky	$F_{g\text{-sky}}$	0.94
8	Shape factor between bed and glass	F_{bg}	0.9
9	Mc Adams constant	a,b,n	5.61, 1.09, 1
Sand Parameter			
10	Bed absorptivity	α_b	0.87
11	Sand specific heat	C_h	$0.8 * 10^3 \text{ J}/(\text{kg}\text{°C})$
12	Bed thermal conductivity	K_b	$2.2 \text{ W}/(\text{m}\text{°C})$
13	Stefan–Boltzmann constant	S	$5.67 / 10^8 \text{ W}/\text{m}^2\text{K}^4$

3.2.7 Modeling the Double Slope Solar Glass Box Prototype

Before the actual prototype was built one small representative model was made from carton and locally available materials so that correction could be made to save money and time. The model is indicated in the figure 3-7,3-8,3-9 and 3-10 below.



Figure 3-8: Ash Box and Sand Box assembled Model



Figure 3-9 : Assembled Model of the Prototype

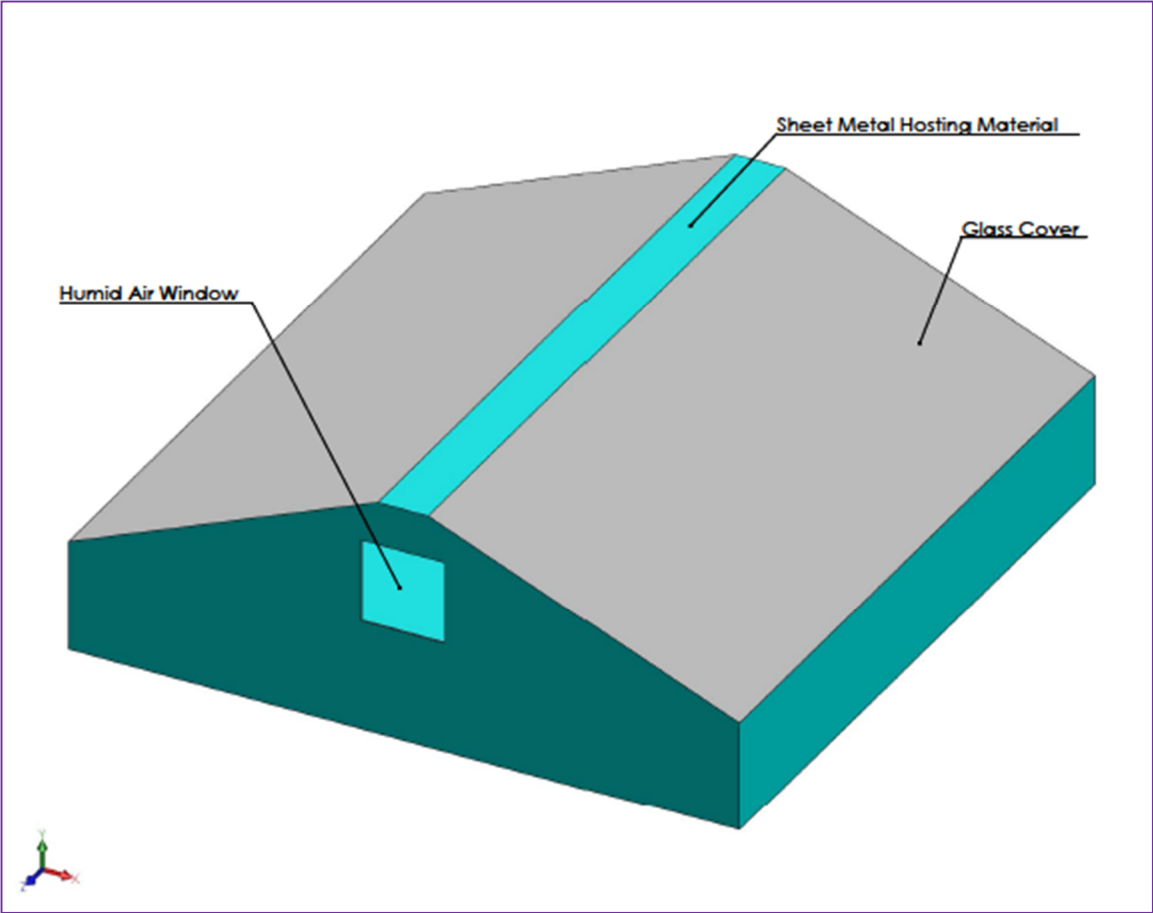

Figure 3-10: Drawing Model

3.2.8 Design Description

The solar water extractor device has the shape of a two sided triangular glass box, 1m by 1m selected sand box; 1.2m x 1.20m thermal insulation box made from wood ash and the vertical distance from desiccant bed is 0.22m. On both sides 0.15m by 0.15m windows will be constructed. The device is set on 1m high stands with casters to make it mobile. The source of air flow is natural and no fan is considered. For the regeneration process solar energy is used.

Table 3-10: Actual Prototype Production

<i>No</i>	<i>Components</i>	<i>Material</i>	<i>Dimensions</i>
1	Casing-1 (Ash box)	Sheet metal	1.2m x 1.2m x 0.25m
2	Humid air inlet (2 windows)	Sheet metal	0.15m x 0.15m
3	Insulation	Wood Ash/Fiber Glass	0.2m ³
4	Casing-2 (Sand Box)	Sheet metal	1.0m x 1.0m x 0.15m
5	Bed Area	Sheet Metal	1m ²
6	Composite material-1 (Collector)	River sand	0.15m ³
7	Composite material –Powder Desiccant	CaCl ₂	2kg
8	Sand air gap tube	Steel pipe	1.0 m length 3 mm dia (#4)
9	Condensate trough	Aluminum	1.2 m length 2 mm width
10	Glazing cover (condenser) –flat collector	Clear Glass	3mm thick
11	Water container	Plastic bottle	Two (600ml each)
12	Water collector cover	Jute (Enset Fiber)	Covered the plastic bottle
13	Sealant	Tire waste	0.59m x 0.435m x 0.08m
14	Stand	Steel pipe	1.0m high above ground
15	Wheel Caster for maneuvering	plastic	80mm : 2Fixed & 2 flexible

Table 3-11: Overall Project Expenses

No	Expense code	Total (ETB)	Remark
1	Internet access	2,000.00	
2	Carton made prototype	500.00	
3	Steel made prototype	10,000.00	
4	Stand made from Metal	3,000.00	
5	CaCl ₂ 1kg	1,000.00	
6	Ash collection and sorting	300.00	
7	Special River Sand from Diredawa	600.00	
9	Loading and unloading	100.00	
10	Laborer for 3 days	1300.00	
12	Printing, binding and laminating	1,500.00	
13	Advising & Registration fee	9,000.00	
14	Miscellaneous	2,000.00	
	<i>Total</i>	<i>34,250.00</i>	

3.2.9 Components of the Prototype

The prototype consists of river sand, calcium chloride, ash, sheet metal box, 3mm thick clear glass and a water reservoir. The system uses a clear flat glass, inclined triangular form exposed to atmospheric humid air as an absorbent. Wood ash is used to insulate or prevent sun light energy which is collected during day time.

a) Stand

The stand has four legs on four casters for easy maneuverability; it is used to support all the components and composite material and insulators: ash box with glass box, sand box and water collector cylinder. All the four legs are attached to the lower and upper bases with bolts and nuts to transport easily.

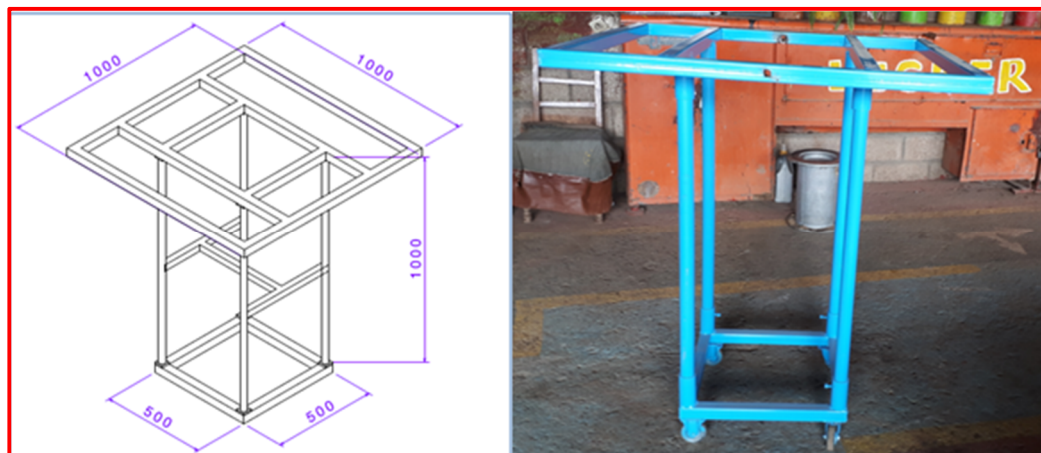

Figure 3-11: Stand of Solar Desiccant Box

b) Ash Box

Ash box is made of 1.5mm sheet metal having dimensions 1.2m x 1.2m x 0.25m. It supports the glass box, sand bed box, water collector plastic bottle and water channels on both sides. Wood ash is used as a thermal insulation material. The use of wood ash as a thermal insulation is the experience of country side moms that they used to keep and store fire in the ash for 10hour. This box is fixed to sand by bolts and nuts.



Figure 3-12: Ash Box

c) Sand box

Sand box is made of 1mm sheet metal having dimension 1.0m x 1.0m x 0.15m. It is used to hold river sand and desiccant material. For the purpose of increasing air gap and helping the entrance of solar radiation four units of $\phi 20$ by 100mm steel pipe is inserted. To avoid the metal contact with calcium chloride a plastic sheet is covered.

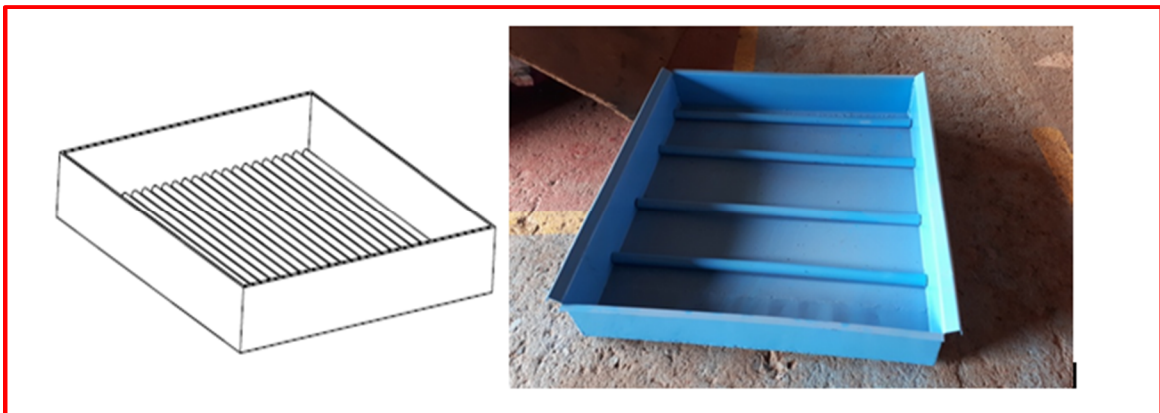

Figure 3-13: Sand Box

d) Flat Surface Double Slope Solar Glass Box

This box is the central part of the project. A 3mm clear glass with single glazing has been installed on 30° inclined steel frames at two sides. The box has two windows having dimensions of 0.15m x 0.15m for air entering to the sand box. Water way channels and a water collector plastic bottle are installed on the glass box frame. For easy transportation the glass box is fixed to ash box by bolts and nuts. To minimize escaping of vapor and solar thermal heat frame of solar box is backed with ash on the two sides.

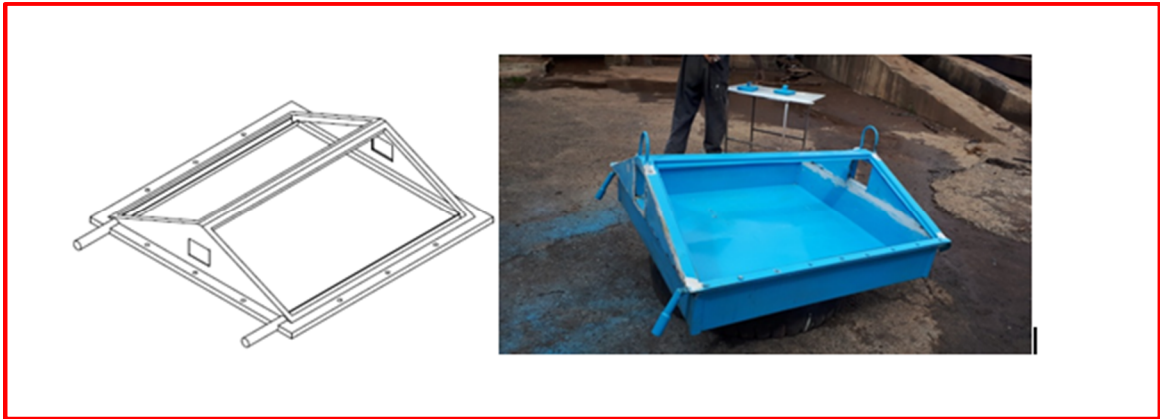

Figure 3-14 : Solar Glass box system

e) Water Collector Plastic bottle

600ml highland or any water brand of plastic bottle was used in this project. To avoid loss of solar thermal and water vapor it was covered with jute. Jute (kacha) insulation is used by trucks drivers to wrap potable water containers to keep water cooled.



Figure 3-15: Plastic bottle wrapped with Jute

3.3 Experimental Methods

3.3.1 Testing Instruments

a) Humidity Measurement

Humidity is measured by Hygrometer. Some main methods are as follows:

i. Relative humidity sensor (electrical impedance):

The hygrometer is based on an electronic component that absorbs water vapor according to air humidity, and changes electrical impedance (resistance or capacitance). The instrument is usually in the form of a “probe” attached directly, or by a cable, to electronics unit to display the relative humidity reading.

ii. Condensation principle hygrometer:

Hygrometer is using cooling to induce controlled condensation. The stable temperature at which this occurs is measured and reported as dew point or frost point. A usual format is a cooled mirror with optical detection of condensation used as feedback to control the mirror temperature.

iii. “Dew-point” probe

Hygrometer based on an electronic sensor changing electrical capacitance on absorbing water, capable of measuring trace levels of water vapor in very dry gases. Often scaled in units of dew point (or frost point) – hence the instrument name – but readings can be displayed in other terms.

iv. Psychrometers (wet- and dry-bulb hygrometer)

Hygrometer is using evaporative cooling as a measure of humidity. A dry thermometer is compared against one sheathed in a wet wick, in moving air. The paired temperature values can be used to find the humidity using tables or by calculation (sometimes internally calculated and displayed directly by modern psychrometers).

v. Mechanical hygrometer

Hygrometer is using change in length of hair (hair hygrometer) or other organic material to measure humidity. Some types record on a chart driven by clockwork or batteries. Very basic types are not powered at all. Electronic sensor-based hygrometers are usually preferred now, but many mechanical hygrometers remain in use for room monitoring.

b) During the experiment this tool was used ‘5 in 1 Environmental Meter Model: EN300’:

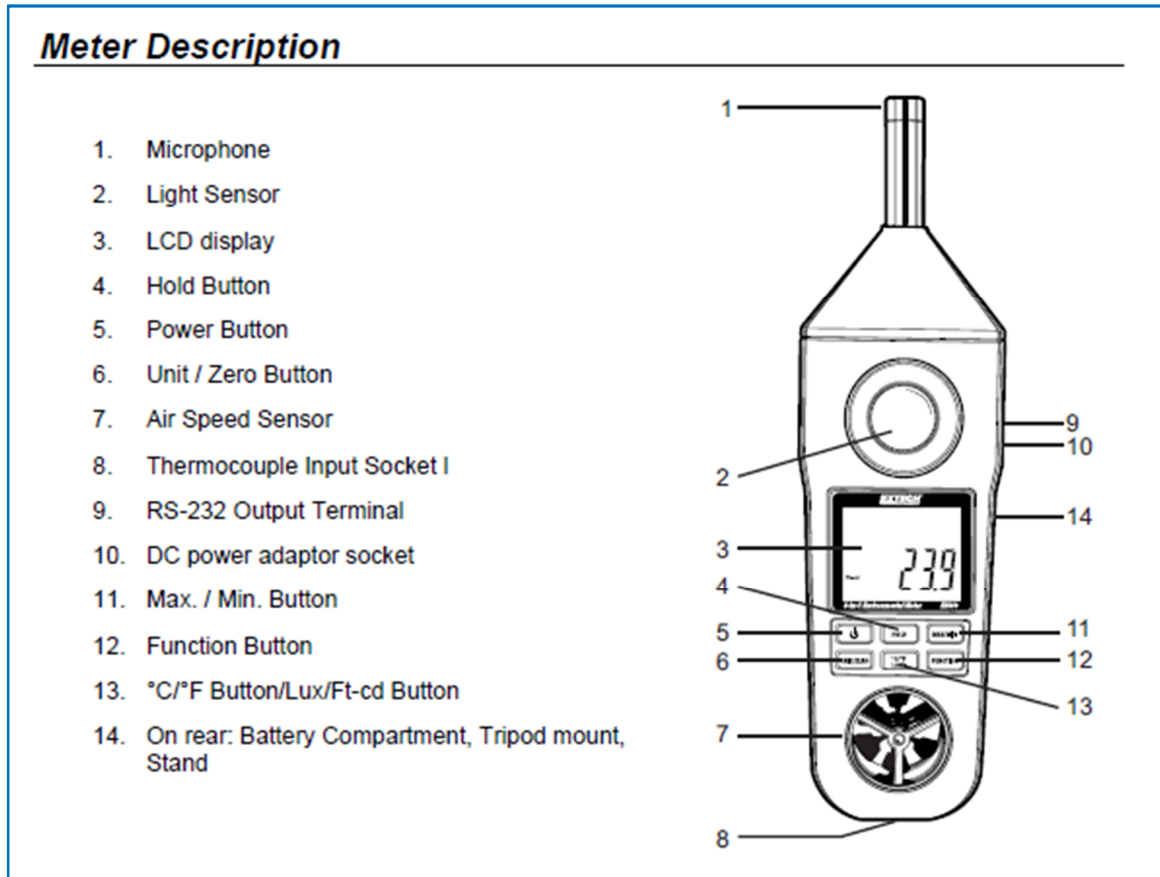

Figure 3-16: Five in one Environmental Meter

c) Ambient temperature

Air temperature is a key measurement alongside relative humidity. This is because the “relative” aspect is effectively “relative to temperature” (how saturated the gas is at its current temperature). For a given air sample, a rise in temperature means a fall in relative humidity. For example, at a humidity of 50 %rh, a temperature rise from 20 °C to 21 °C will cause relative humidity to fall by about 3 %rh. Because of this (and because temperature is usually of interest anyway) relative humidity instruments generally have integral temperature sensors. This tool is used to measure surrounding ambient temperature.

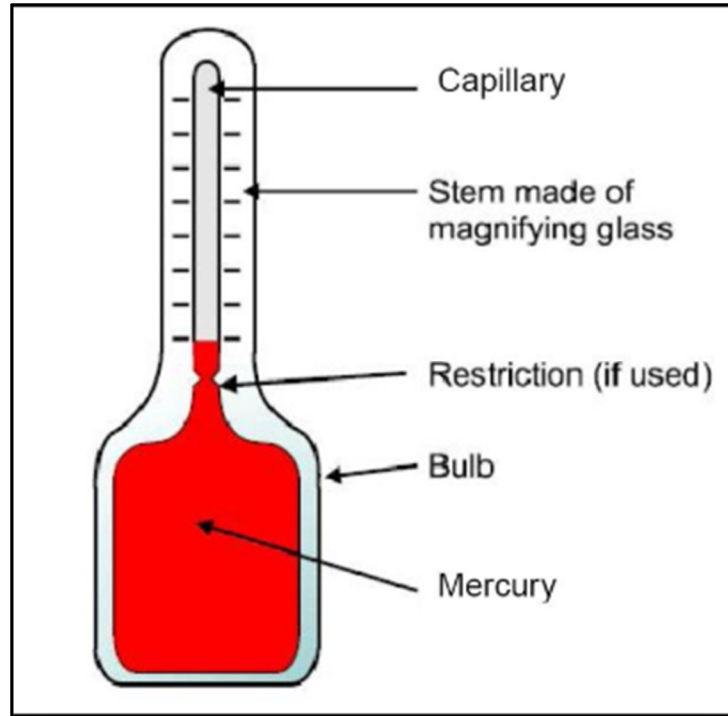

Figure 3-17: Thermometer

3.3.2 Area selection for test

The appropriate site was selected for the test. To minimize shadow and increase storage capacity of the prototype, selection criteria must free from shadow and the availability of wide area that would facilitate the testing procedure. The selected site is free from building shadow starting from 7:30 in the morning up to 4:30 in the afternoon. Hence, for eight testing hours the site clear is from any shadow.

3.3.3 Mixing ratio of sand and calcium chloride in the prototype setup

It was well explained that experiments have been done with desiccant solar collector systems to harvest atmospheric water in the climatic condition of Taif city, in Saudi Arabia with application of calcium chloride (CaCl_2) determined the using ratio as [43]:,

- 1kg of sand is mixed with 0.15 kg of powder.
- Solution concentration of calcium chloride (CaCl_2) at equilibrium with the night conditions is about 30%.
- Depth of absorber material is **15mm** which was taken similar experiment conduct

a) Experimental set-up

The picture of the experimental set-up is shown in Figure 3-18 below. Prototype consists of the following main parts:

- a) Sheet metal box : Ash box and Sand box
- b) Glazing
- c) Connecting pipe
- d) Water collecting plastic bottle
- e) Desiccant material
- f) Wood ash/fiber glass and Jute (kacha)
- g) River sand

Atmospheric water generator prototype is designed and constructed to investigate water generation from humid air. Inner prototype was fabricated by sheet metal (0.8mm thick) and it is shaped rectangular box with dimension of 1m length, 1m width and 0.15m height. Fiber glass sheet (0.005 m thick) is used for insulation between sand box and plywood frame in order to reduce the sides and bottom losses of heat transfer through four sides and base of the system. The outer covering and base ash box made by sheet metal (1.5mm thick) and it is shaped rectangular box with dimension of 1.2m length, 1.2m width and 0.25m height and it is shaped triangular on two sides. 10 cm thick wood ash is filled the box to avoid further heat transfer during day time. To minimize corrosion Aluminum channel box with 1.2m length and 0.02m galley width is fixed on both to collect condensate during day time.

Glass cover box is made of sheet metal frame and shaped triangular with dimension of 1.2m length, 0.68 with and 0.22m height and a slope of 20° is given to the glass cover to both sides equally. RTV Silicone and glass putty are used as a sealing material for filling the gap between the glass cover and base frame in order to prevent the vapor leakage. Two side of the glass frame is insulated by wood ash.

Two windows are made in glass cover box with size 0.15m x 0.15m used to introduce humid (ambient) air during night time for the adsorption. These windows also internally insulated by wood ash. Two Connecting pipe made of galvanized metal with the dimension 0.02m diameter and 0.15m length. These pipes are used to connect aluminum condensate trough and water collect plastic bottle. Two units of a 600ml plastic bottle is

attached to glass on one side. The bottles are wrapped by Enset Jute and externally soaked in water to facilitate cooling and condensate the hot vapor.

b) Operation and working principles of prototype

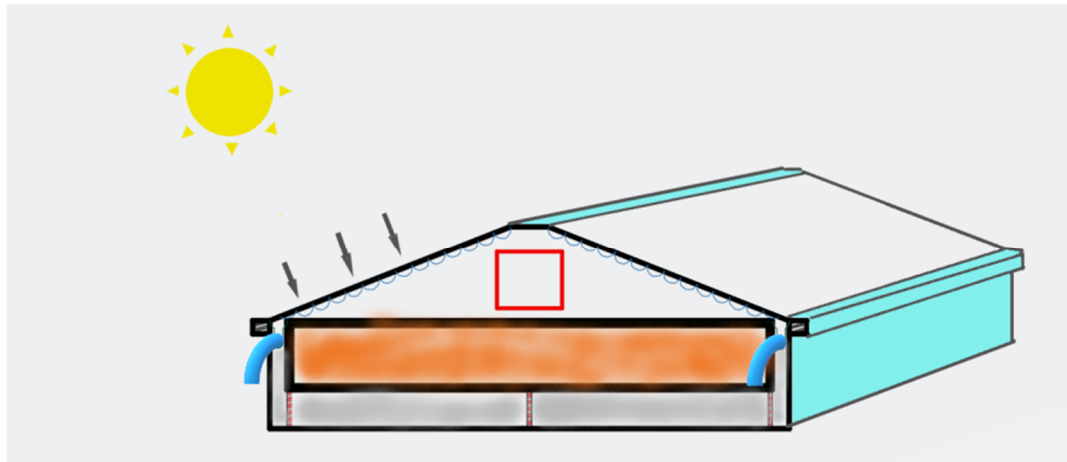
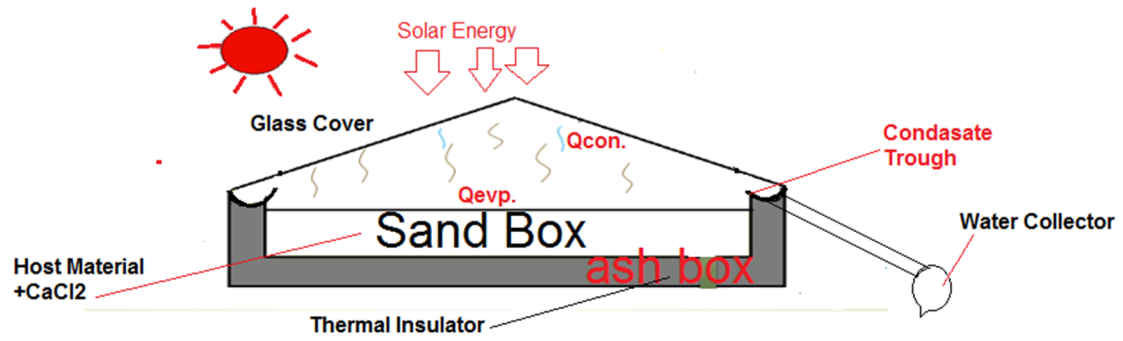

Figure 3-18: Prototype Pictorial representation

c) Sand and CaCl₂ Mixture preparation

Selected river sand from Diredawa in the ratio of 1kg and 0.15kg of CaCl₂ solution is mixed and added together into the glass cover box. The ash box is insulated by ash of 0.05 m thickness surrounding the sand box and sand box was also insulated by fiber glass. During the experimental test, the device put at an angle of about **30°** to the horizontal, which is nearly the **latitude** angle of the location. During day time, the two air window closed so that the prototype is an airtight triangular metal box containing composite material enclosed by clear 3mm glass cover to trap the solar energy inside it.

The basic operation of the air to water extraction system was assumed to be a continuous cycle. The sand box holds river sand with calcium chloride desiccant (CaCl_2 powder) mixed in the ratio of 1:0.15 by weight. The desiccant was subjected to ambient atmosphere to absorb water vapor in the night. The driving force of adsorption process was because of the vapor pressure difference between atmospheric air (moist air) and the surface of composite desiccant materials. The composite desiccant material (adsorbent) has lower vapor pressure than that of the atmospheric air. This process is continued till the equilibrium conditions are reached, i.e. when the vapor pressure on the adsorbent surface is the same as that of atmospheric air.

3.3.4 Measurements and tools

Global solar radiation and wind speed data are taken by the SRRA (Solar radiation resource assessment) station at Adama. Temperature is measured by calibrated Ni-Cr thermocouples connected with multichannel digital thermometer at various points of solar atmospheric water generator, bed temperature (T_b), glass cover temperature (T_g), and vapor temperature (T_v). Ambient air temperature (T_a) is measured by thermometer.

Experiments were conducted at Adama; Oromia National Regional State, Ethiopia in the month of January 12, 2019. The prototype is placed East – West during nighttime and in north- south direction during daytime with the condensing glass cover inclination facing north - south in order to maximize the receiving of solar radiation.

Range of solar intensity is taken as $0.0 \text{ W/m}^2 - 915.0 \text{ W/m}^2$ and that of wind velocity is taken as $0.25 \text{ m/s} - 5.0 \text{ m/s}$ based on actual data available from SRRA station at Adama. Values of bed temperature, glass temperature, and ambient air temperature were measured directly and the same were used in the **theoretical calculations**.

The cycle consists of three processes.

I. During nighttime (Adsorption method):

In this process, humid air is passed over (a sand and calcium chloride) adsorbing material where water vapor is going to be adsorbed while cooling the adsorbing material. For the adsorption process, at night time, the two windows will be left open to the atmosphere at 6:00pm. Humid (ambient) air introduced into the adsorption sand box and in contact with the desiccant bed at night and water was absorbed by the desiccant.

II. During daytime (regeneration/desorption process):

During the regeneration process, the two windows were closed at 7:00am (morning). In the morning at 7' o'clock, the side windows are closed and the setup is exposed to the direct sunshine. The transparent 3mm thick glazing allows most solar radiation to transmit through. So, the sand mixture absorbs the transmitted radiation. As a result, the temperature of the composite desiccant material rises, so the vapor pressure of composite desiccant material increases. Hence, the vapor pressure difference between the composite desiccant materials and glass box (upper ceiling) is created. At this time, desiccant is regenerated and the captured water started to evaporate from sand box (high temperature), water vapor is condensed on the inner side of the inclined glass on the both sides. The coalescing small drops runs down along the surface due to gravity and get collected gradually in a plastic bottle through condensate channel. Due to slope in the water collection tray the water goes to the water measuring container through a connecting pipe. The maximum regeneration temperature depends upon the available heat. The amount of collected water is measured at regular intervals of 30 minutes [61].

In conclusion, the humidity can be absorbed by the calcium chloride from the air accumulating moisture on the surfaces of the sand, and at the day time the window will be closed at 7:00Am in the morning. When the sun shines in the morning the bed absorbs the incident solar radiation and consequently the bed temperature increases, as a result the vapor pressure of the solution on the bed surface increases and vapor pressure difference between the bed surface and glass cover is created. At this moment, evaporation of moisture from the bed is carried out with subsequent condensation on the inclined glass surface. The drops of condensate are collected and led away from the system by gravity through a specially designed channel. Evaporation and condensation continue until the vapor pressure on the bed surface is equal to that on the glass surface.

III. Output capturing process

Finally, the hot water vapor is condensed and cooled in the third process using air-cooled plastic bottle condenser.

3.3.5 Measure and record the amount of water collected.

At the end of the day the windows are opened and the bed was allowed to cool until the vapor pressure on its surface decreases to a value lower than that of the ambient air.

Chapter 4 : Results and Discussion

4.1 Introduction

By searching similar climatic and elevation with Yabello, the experimental test was executed at Adama.



Figure 4-1: Picture of the prototype

4.2 Experimental & Discussion

The following conclusions are drawn from prototype test at Adama on 18th and 19th of March month, 2019:

- Maximum ambient temperature was 26°C at 7:00 AM and 19 °C at 6:00 PM
- Maximum glass surface temperature on the mid-day was 30°C,
- Maximum relative humidity measure was 49% at mid night
- Natural wind speed at 1.50m was 1m/s.
- Sunshine radiation shined for 8hours per day
- Prototype internal temperature was measured using thermocouple after both windows closed in the interval of every one hour recorded as follows:



Figure 4-2: HI 92801C K-Thermocouple [le picture during test

<i>No</i>	<i>Hour (H)</i>	<i>Temperature (°C)</i>
1	9:00 AM	38
2	10:00 AM	49
3	11:00AM	65
4	12:00AM	78
5	1:00PM	89.1
6	2:00 PM	88
7	3:00 PM	85
8	4:00PM	82

Table 4-1: Prototype internal temperature

Graphically:

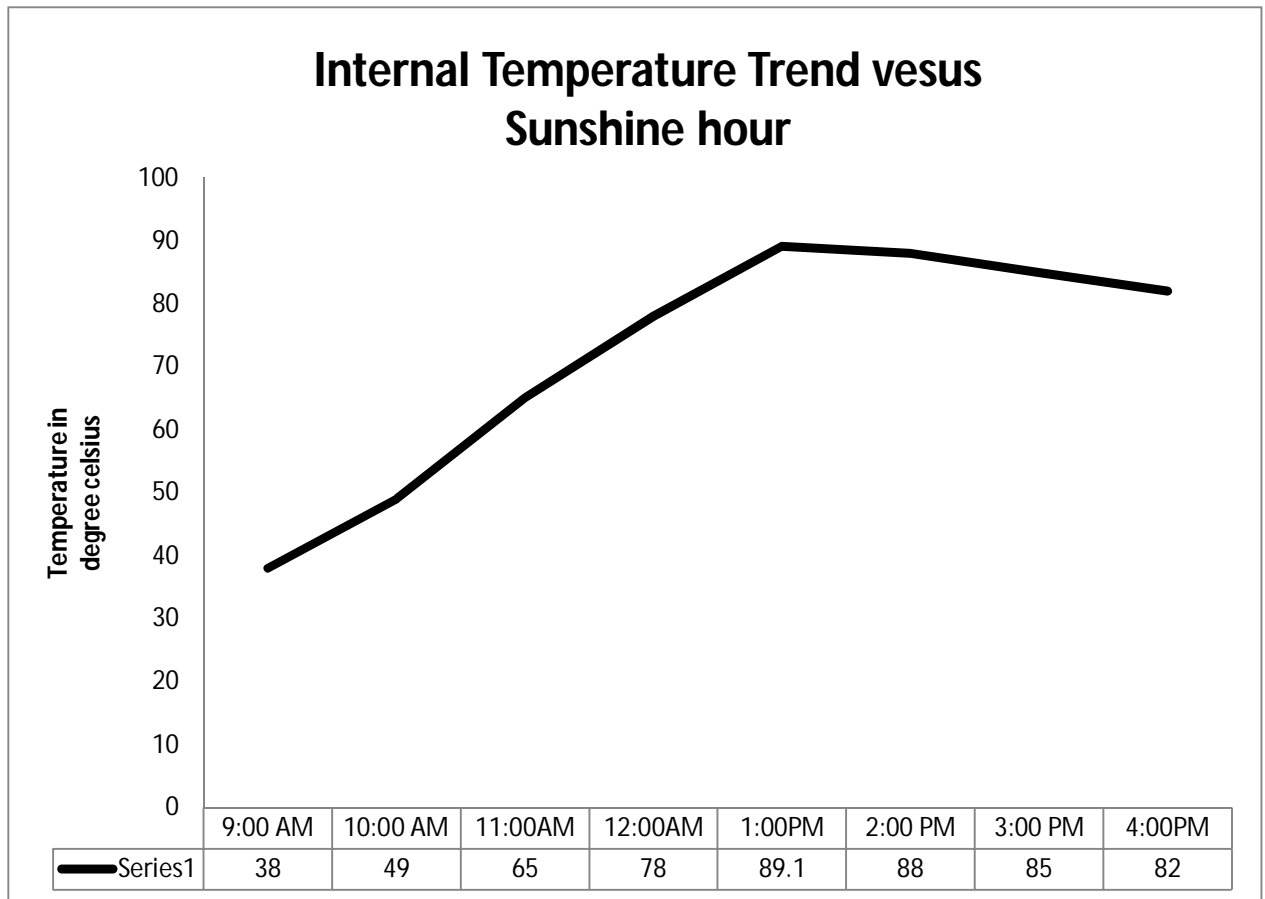

Figure 4-3 Test Result Temperature versus Time

Discussion:

Prototype was installed in Adama where free of shade and adjusting one window toward the incoming wind direction. Prototype was filled with river sand and 1kg of calcium chloride and left opens the windows over the night. Water was not generated on one day tested as per the designed proposed. But, there was a promising that show a few of water was condensed on the internal surface of the glass as indicated on the picture below.



Figure 4-4: Picture of water condensation on inner surface of the glass

The lesson learnt why water was not generated is that:

- After closing and fitting one plastic jar Prototype should be tested technically for air tight that via on one port of plastic jar. Because lacks of good evaporation was due to leakage of air at gasket met and fittings.
- Fan should be fitted to increase incoming air speed.

In general this project has not been a failure reasoning that the research has shown a promising result if some short coming is able to be adjusted. The prototype targeting promoted development and understanding of calcium chloride desiccation technology to generate water and has learned valuable lessons atmospheric water generator as a whole to use as one of alternative resource for potable water where there is severe shortage happening

4.3 Analytical Result & Discussion

4.3.1 Introduction

Heat transferred in the prototype's internal system was heat loss from the system base and sides, heat transferred by conduction through the air gap between the sandy bed surface and glass cover, heat transferred by evaporation from the bed to the glass cover, heat transferred by radiation between the bed surface and glass cover and finally heat transferred from glass cover to the ambient. A solar cooled water harvester was designed based methods described by Manoj Kumar [34]. The size of the device was initially scaled to get **1liter/day /m²** from a triangular solid desiccant box. This was assuming that all physical properties are constants through the operation time.

- All evaporated water should be condensed at the glass cover.
- Completely closed system during day time operation (regeneration process).
- Condensation and evaporation processes occur simultaneously.

Table 4-2: Specification of double slope Flat solar Collector [34].

<i>Type</i>	<i>Double Slope</i>	<i>Reference</i>
Hosting material	River Sand & thickness: 15cm	Prototype
Desiccant	CaCl ₂ in powder	Ditto
jute for plastic bottle insulation	Enset Jute (local material)	
Insulation material	Wood Ash/Fiber Glass	
Area of Glass Box	0.754596m ²	
Width of Glass box	628.83mm	
Length of Glass Box	1200mm	
Type of Glass Cover	Single glazing	
Thickness of glass covered	3mm	
Angle of inclination of glass cover	30°	
solar radiation intensity (H) is on average estimated to be	5.5kwh/m ² /day	
Specific Energy Consumption required to extract 1liter of water	0.5kwh/per liter of water extracted	[62]
Regeneration Temperature from Desiccant material	40 -70 °C	[22]
The bed and glass cover temperatures reached to be	112 and 70 °C (peak value)	

4.3.2 Thermal Analysis of Double Flat Plate Solar Glass Cover

a) Heat transferred element in Solar Glass Box

There is various heat transfer elements assumed in the prototype during the test for water extraction from air. These are:

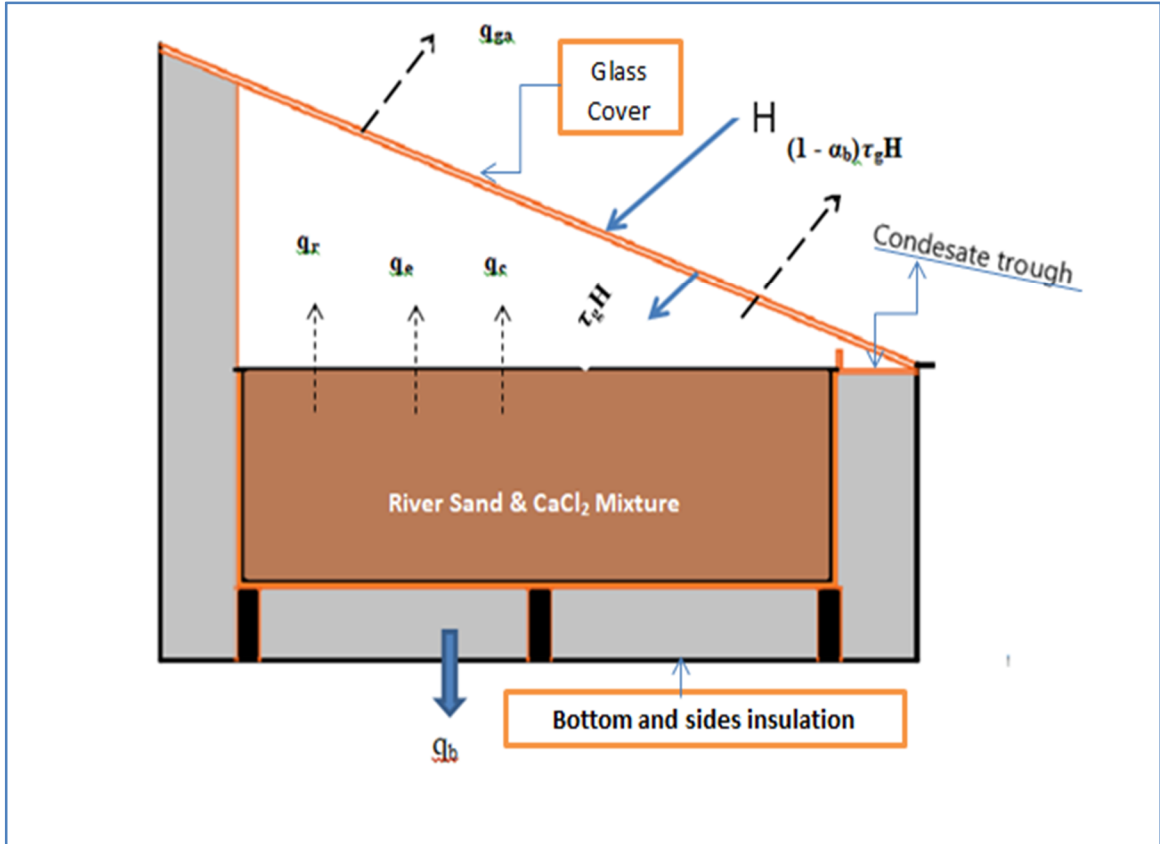

Figure 4-5: Prototype Detailed Section View

As study was conducted by Abd elnaby Kabeel [63] .The energy flow diagram model was constructed based base on heat transferred in the system. Energy balance of the system in the prototype is very similar to figure 4-6 and therefore, the project will be tested mathematically by this system and taken all formulae and steps from Kabeel study journal.

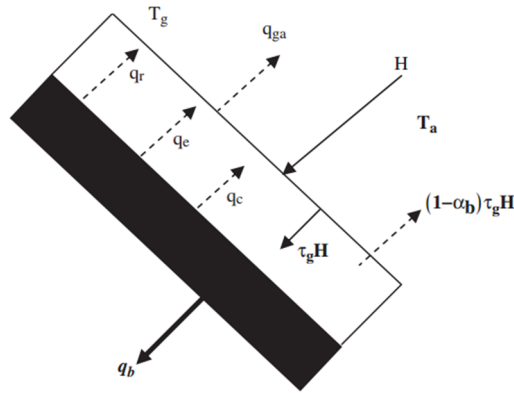

Figure 4-6: Energy flow diagram for the proposed system [63]

The Formulae are adopted and taken from Kabeel [63] uploaded as follows:

As seen in Figure 4-6, the heat balance equations of the glass cover and the system as a whole can be expressed as follows:

- ✓ The heat balance equations of the glass cover:

$$q_{ga} = q_e + q_c + q_r + \alpha_g H \quad [1]$$

- ✓ The heat balance equations of the system as a whole:

$$\alpha_g H + \alpha_b \tau_g H = q_{ga} + q_b + C_s \left(\frac{dT_b}{dt} \right) \quad [2]$$

The average thermal capacity of the system, C_s , is evaluated as the summation of thermal Capacities of different materials used (i.e. metals, sand glass and calcium chloride) as given in the following expression:

$$C_s = (mC)_{\text{steel}} + (mC)_{\text{sand}} + (mC)_{\text{CaCl}_2} + (mC)_{\text{glass}} \quad [3]$$

As indicated by Kabeel's experimental data, thermal capacity of the materials ($\text{Jkg}^{-1}\text{C}^{-1}\text{k}^{-1}$)

- ✓ Metal (steel) :444
- ✓ River Sand :800
- ✓ Calcium Chloride (salt):3000

✓ Glass cover :750

Heat transfer property of the glass cover is also taken from Kabeel's Journal as follows:

- ✓ The glass cover transmissivity: **0.87**
- ✓ The glass cover absorptivity: **0.12**
- ✓ The glass cover emissivity is assumed to be **unity**.

Values of q_{ga} , q_c , q_r , q_e and q_b are expressed as given by Gad et al. (2000) as:

The heat transfer between glass cover and ambient air (q_{ga}) is determined by:

$$q_{ga} = h_{ga}(T_g - T_a) + F_{g-sky} * s \left[(T_g + 273)^4 - (T_{sky} + 273)^4 \right] \quad (4)$$

$$\begin{aligned} &= 7.027 (60 - 30.2) + 0.94 * [(333)^4 - (293.2)^4] \\ &= 209.405 + 0.94 * 5.67 * 10^{-8} * (4,906,175,901.26) \\ &= 247.886 + 261.49 \end{aligned}$$

$$q_{ga} = \underline{\underline{470.895}} \text{ W m}^{-2}$$

where:

F_{g-sky} : the shape factor between glass cover and sky,

h_{ga} : is the convection heat transfer coefficient between glass and ambient air that can be evaluated from **Mc Adam's relation as follows:**

$$h_{ga} = a + bvn \quad (5)$$

$$= 5.61 + 1.09(v)^v = 1.3(\text{max. from meteorological data @Yabello})$$

$$= 5.61 + 1.09(1.3),$$

$$h_{ga} = \underline{\underline{7.027}} (\text{W m}^{-2} \text{K}^{-1})$$

Where a, b and n are coefficients dependent on the roughness of the cover and wind speed (Elsayed, 1983).

The convection heat transfer coefficient between glass and ambient air (h_{ga}) mainly depends on wind velocity (v).

The conduction heat transfer between bed surface and glass cover (q_c) is calculated by:

$$q_c = \frac{k_a(T_{bs} - T_g)}{\Delta y} \quad (6)$$

$$= 0.3 \left(\frac{80.047 - 60}{0.22} \right)$$

$$= 0.3 \left(\frac{20.047}{0.22} \right)$$

$$= 0.3 * 91.1223$$

$$q_c = \underline{27.34} \text{ W m}^{-2}$$

where:

ka – the thermal conductivity of the air gap

Δy - air gap thickness,

Radiation heat transfer between bed surface and glass cover (q_r) is calculated by:

$$q_r = F_{bg} * \sigma [(T_{bs} + 273)^4 - (T_g + 273)^4] \quad (7)$$

$$= 0.9 * 5.67 * 10^{-8} [(80.047+273)^4 - (60+273)^4]$$

$$= 0.9 * 5.67 * 10^{-8} [(353.047)^4 - (333)^4]$$

$$= 0.9 * 5.67 * 10^{-8} [3,239,303,763.39]$$

$$q_r = \underline{165.30} \text{ W m}^{-2}$$

Where

F_{bg} - is the shape factor between bed surface and glass cover.

Evaporation heat transfer due to the evaporated water from the bed (q_e) can be estimated as:

$$q_e = 0.0061 \sqrt[3]{\left[(T_b - T_g) + \left(\frac{p_{bs} - p_g}{0.265 - p_{bs}} \right) (T_{bs} + 273) \right]} * (p_{bs} - p_g) Lb \quad (8)$$

$$= 0.0061 \sqrt[3]{\left[(90 - 60) + \left(\frac{0.070183 - 0.019947}{0.265 - 0.070183} \right) (90 + 273) \right]} * (0.070183 -$$

$$0.019947) * 1,634.463 * 10^3$$

$$= 0.0061 \sqrt[3]{\left[(30) + \left(\frac{0.0500713}{0.194817} \right) (363) \right]} * (0.0500713) * 1,658.353 * 10^3$$

$$= 0.0061 \sqrt[3]{\left[(30) + 93.2972 \right]} * (0.0500713) * 1,658.353 * 10^3$$

$$= 0.0061 \sqrt[3]{123.29721} * 83.0359 * 10^3$$

$$= 0.0061(4.9972) * 83.0359 * 10^3$$

$$q_e = \underline{2.53 * 10^3} \text{ W m}^{-2}$$

Where, from thermodynamics Saturated Temperature table 4:

a. 60°C $P_{sat} = 19.947 * 10^{-3}$ Mpa

b. 90°C, $P_{sat} = 70.183 * 10^{-3}$ Mpa

The rate of heat loss from system base and sides to the surroundings (Wm^{-2}) is given by:

$$q_b = h_b(T_b - T_a) \quad (9)$$

Saturation pressure and latent heat of water can be calculated as a function of T_b using the following equation (Dunkel, 1961):

$$\text{Log}_{10}(P_b) = \quad (10)$$

$$-3.21254 + 3.13619 \times 10^2 T_b - 1.22512 \times 10^{-4} T_b^2 + 3.63841 \times 10^{-7} T_b^3 - 5.67607 \times 10^{-10} T_b^4$$

The latent heat of the evaporated water (L_b) can be estimated by:

$$L_b = (2501.67 - 2.389 T_b) \times 10^3 \quad (11)$$

$$= 10^3(2501.67 - 2.389 \times 363)$$

$$= 10^3(2501.67 - 867.207)$$

$$L_b = \underline{1,634.463} * 10^3 \text{ Jkg}^{-1}$$

Instantaneous system water productivity, P , can be evaluated using the following relation:

$$P = \frac{q_e}{L_b} \quad (12)$$

The operation efficiency of the system (η) can be defined as the ratio of heat consumed to evaporate water to the total incident radiation as follows:

$$\eta = \frac{q_e}{H} \quad (13)$$

The mass transfer rate b is obtained from the following relations:

$$\beta = \frac{M_w}{A_r \cdot \Delta P \cdot \Delta \tau} \quad (14)$$

where ΔP is the vapor pressure difference between ambient air and desiccant surface, which can be expressed as:

$$\Delta P = P_\infty - P_v \quad (15)$$

Vapor pressure of calcium chloride solution on the bed surface, P_v , can be calculated as a function of solution temperature within a temperature range from 10 to 65 °C and concentration range from 20 to 50% according to the following equations (Hamed, 2000):

$$\text{Ln}(P_v) = A(x) - \frac{B(x)}{T_s + 111.96} \quad (16)$$

Sky temperature is a function of ambient temperature:

$$T_{\text{sky}} = T_a - 10$$

$$= 30.2 - 10, \quad \text{dry bulb temperature } T_a = 30.2^\circ\text{C}$$

$$T_{sky} = \underline{20.2}^{\circ}\text{C}$$

where Pv is in mmHg, Ts in °C, A(x) and B(x) are regression dependent parameters that can be expressed as a linear function of concentration according to the following relations:

$$\mathbf{A(X) = a_0 + a_1x} \quad (17)$$

$$\mathbf{B(X) = b_0 + b_1x} \quad (18)$$

where:

$$a_0 = 10:0624; a_1 = 4:4674$$

$$b_0 = 739:828; b_1 = 450:96$$

For a temperature higher than 60°C, the following relation is used to calculate the vapor pressure for the concentration range from 20 to 50% :

$$\mathbf{\ln(Pv) = C1 - \frac{D1}{Ts+273}} \quad (19)$$

where C1 and D1 are regression constants and obtained from Table 4-3.

Table 4-3: Regression constants

Concentration (%)	C ₁	D ₁
20	19.9418	5053.95
25	20.3898	5244.51
30	19.9915	5133.02
35	20.1957	5244.15
40	20.4864	5411.75
45	19.591	5168.25
50	20.8764	5708.42

The mass of water regenerated from the bed can be evaluated by knowledge of initial mass of solution, initial and final concentration as:

$$\mathbf{M_w = M_1 \left[\frac{X_1}{X_2} - 1 \right]} \quad [20]$$

where

$$\mathbf{X_1 = \frac{M_s}{M_1}} \quad [21]$$

$$\mathbf{X_2 = \frac{M_s}{M_2}} \quad [22]$$

where X_1 and X_2 are, respectively, the initial and final solution concentrations and M_1 and M_2 are, respectively, the initial and final mass of solution.

Where:

- T_g - average glass cover temperature ($^{\circ}\text{C}$)
- T_a - ambient temperature ($^{\circ}\text{C}$)
- q_r -rate of heat transferred by radiation between the bed surface and glass cover (W m^2)
- q_e - rate of heat transferred by evaporation from the bed to the glass cover (W/m^2)
- q_c - rate of heat transfer by conduction through the air gap between the bed surface and glass cover (W m^2)
- q_{ga} - rate of heat transferred from glass cover to ambient (W/ m^2)
- H - incident solar radiation (W/m^2)
- T_g - average transmissivity of the glass cover (dimensionless)
- q_b - rate of heat loss from system base and sides to the surroundings (W /m^2)
- α_b -average bed absorptivity (dimensionless)

Assume that:

T_s = surface temperature reached about 90°C

T_b = the bed temperature reached 80°C

T_g = the glass cover reached 60°C

T_a = Ambient Temperature during day time at Yabello is 19°C

4.3.3 Evaluating of Output using Psychometric Chart

The psychometric chart is more reliable than electronic devices, because it depends on the calibration of thermometers or temperature sensors, which are much more reliable than electrical RH sensors.

The chart helps to determine properties of the moist air.

- Dry bulb
- Wet bulb
- Relative humidity
- Enthalpy

Important calculations based on the psychrometric chart are:

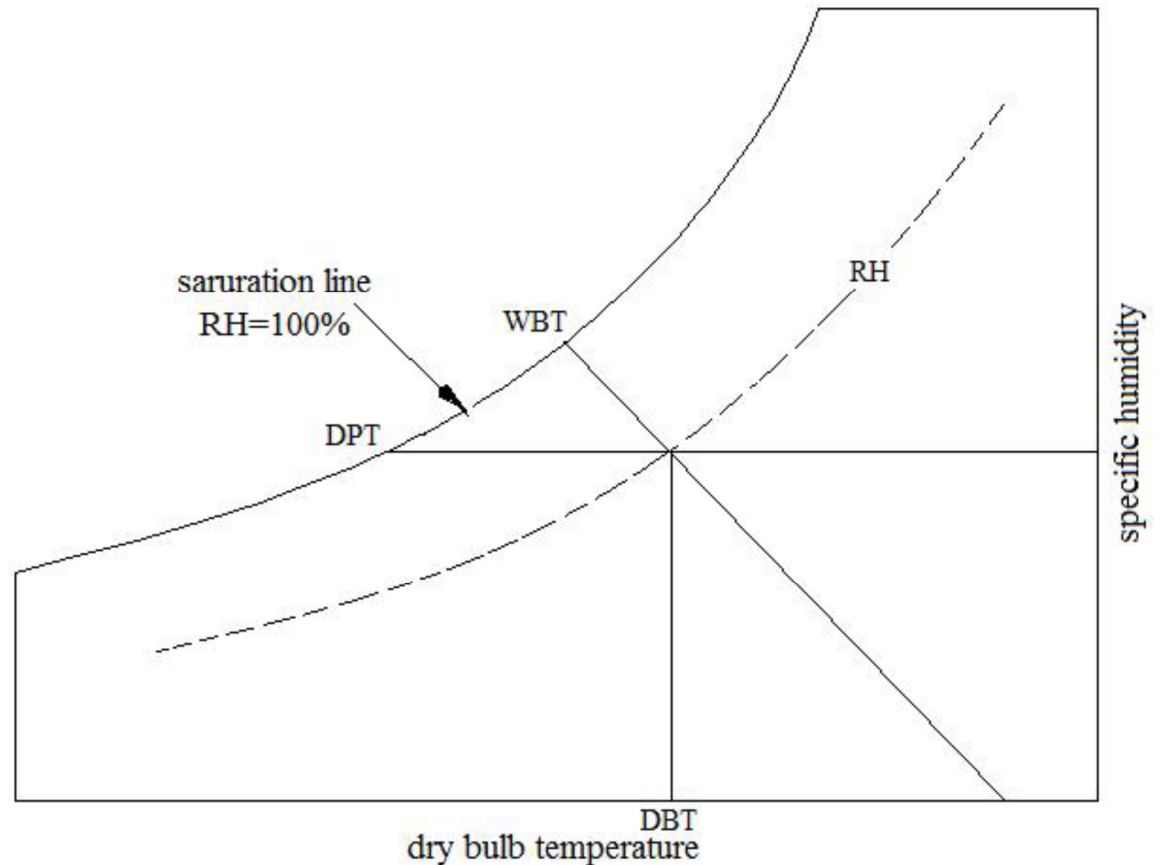

Figure 4-7 : The Psychrometric Representation of DBT, WBT, DPT and RH

- **DBT**- The temperature of the air measured by the ordinary thermometer, when exposed to the atmosphere, is called as the dry bulb temperature of air.
- **WBT**-The wet bulb temperature of air is also measured by the ordinary thermometer, but the only difference is that the bulb of the thermometer is covered by the wet cloth (a piece of cotton wick).
- **DPT** - Dew point temperature of air (liquid water starts to condense when it is heated) is found on the saturation curve where dry bulb temperature and relative humidity lines meet by moving down the dew point is located on the x-axis.

Amount of humidity ratio ($g_{mH_2O}/kg_{dry\ air}$) in the air is found out by using dry bulb temperature and relative humidity from chart. Using this value it is possible determine amount of water produced from the device.

Water produced = Humidity ratio * 110liters

Numerical Formula used:

Dew-point temperature, T_{dew} (For the dew-point temperature range of 0 to 93°C)

$$T_{dew} = C_{14} + C_{15}\alpha + C_{16}\alpha^2 + C_{17}\alpha^3 + C_{18} (pw)^{0.1984}$$

$$= 6.54 + 15.238 + 0.8134 + 0.1095652391 + 0.5626333638$$

$$T_{dew} = \underline{\underline{23.263599^\circ\text{C}}}$$

where:

- T_{dew} = dew-point temperature, °C
 - $C_{14} = 6.54$
 - $C_{15} = 14.526, C_{15}\alpha = 14.526 * 1.049 = 15.238$
 - $C_{16} = 0.7389, C_{16}\alpha^2 = 0.7389 (1.0492119384)^2 = 0.8134$
 - $C_{17} = 0.09486, C_{17}\alpha^3 = 0.09486 (1.0492119384)^3 = 0.1095652391$
 - $C_{18} = 0.4569, C_{18} (pw)^{0.1984} = 0.4569 (2.8554)^{0.1984} = 0.5626333638$
- P_w = water vapor partial pressure, kPa ($P_w = \underline{\underline{2.8554\text{KN/m}^2}}$)
- $\alpha = \ln pw = \ln 2.8554 = 1.0492119384$

4.3.4 Heat Transfer in Glazing Material

Energy absorbed by glass cover depends on temperature difference between glass and fluid, glass and plate, and glass and ambient [59]:

$$I_a \alpha_g = h_a (T_g - T_a) + h_{fg}(T_c - T_f) + h_{r,gp}(T_g - T_p) + H_{r,ag}(T_g - T_a) \dots\dots\dots (1)$$

The radiative heat transfer coefficients from the absorber to the glazing and from the glazing to the ambient are, respectively, given by:

$$h_{r,gp} = \frac{\sigma(T_g^2 + T_p^2)(T_g + T_p)}{\left(\frac{1}{E_g} + \frac{1}{E_p} - 1\right)} \dots\dots\dots (2)$$

$$h_{r,ag} = \frac{\sigma(T_g^2 + T_a^2)(T_g + T_a)}{\left(\frac{1}{E_g} - 1\right)} \dots\dots\dots (3)$$

The convective heat transfer coefficients for air flowing over the outside surface of the glass cover were proposed by Kumar and Mullick [64]. Consider:

$$h_a = 5.7 + 3.8V_w \dots\dots\dots (4)$$

4.3.5 Sensitivity Analysis for chosen variables

In this part it will be explained the effect of sunshine radiation (ambient temperature), bed materials and desiccant concentration in atmospheric water extraction.

(a) Sensitivity Analysis for sunshine radiation (ambient temperature)

The change of temperature and vapor condensation is shown in figure 4-8. The capacity of air to hold water vapor varies with the temperature. On the other hand, it is observed that increasing solar radiation ultimately will increase water vaporization from the sand bed and gives a chance of getting more water. Whereas, as the temperature becomes low and less amount of solar radiation recorded this will lead to high amount of relative humidity. As a consequence it required more energy for heating the bed being evaporated.

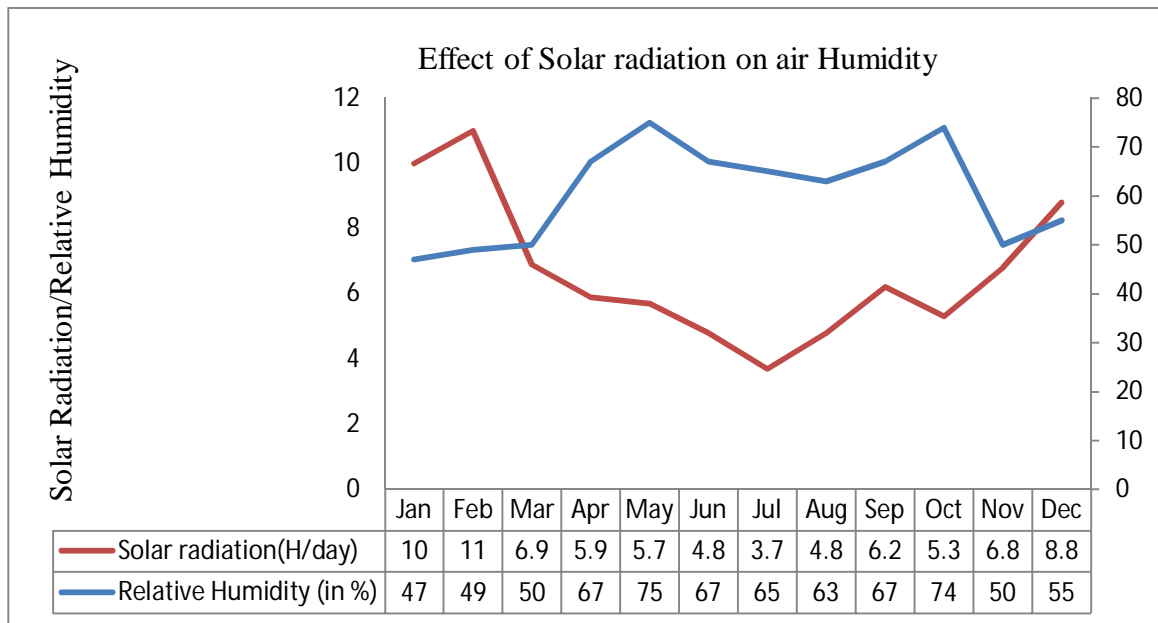

Figure 4-8 : Effect of Solar radiation

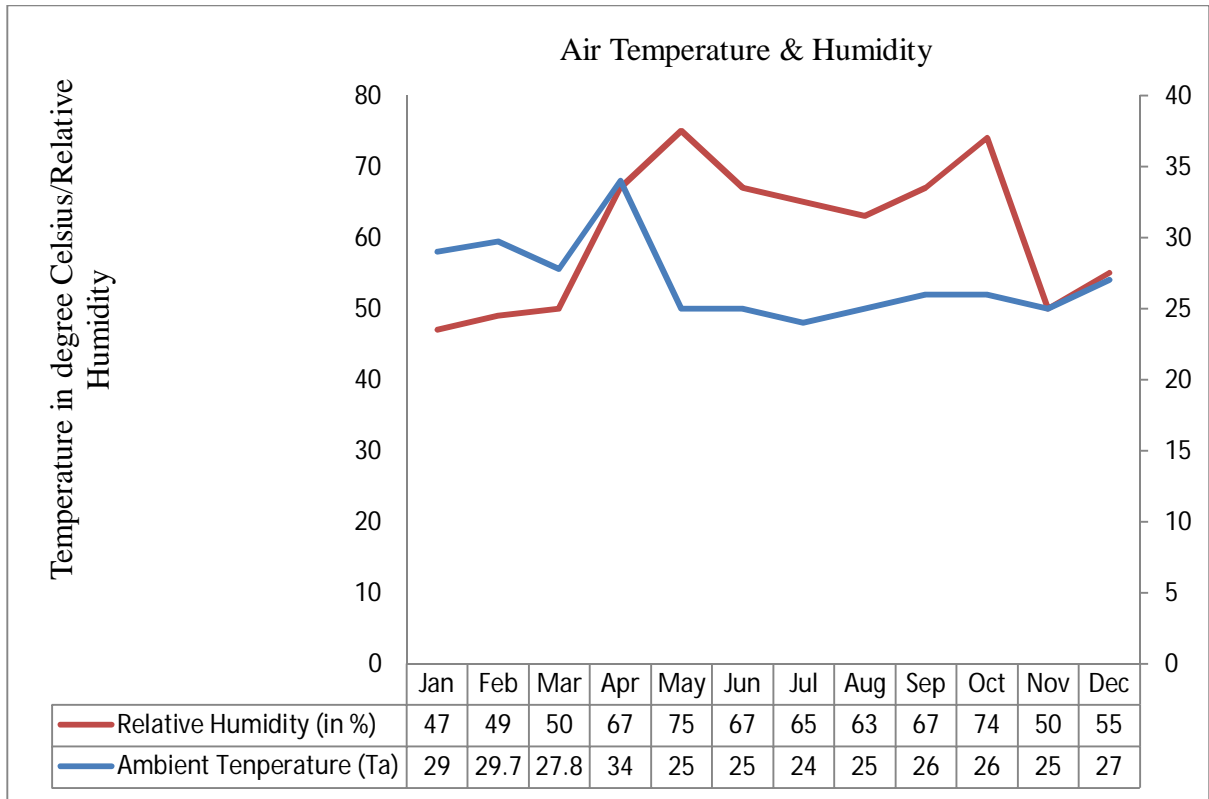

Figure 4-9: Effect of ambient Temperature on Relative Humidity

One important feature of air moisture holding capacity varies with rising ambient temperature. Using the graph of figure 4-10, if we assume that a parcel of air at 24°C is saturated, and then it will contain 30 grams of water vapor in each cubic meter of air (30 g/m³). Now suppose the temperature of the air increases to 30°C *without* increasing the water vapor content. The parcel is no longer saturated because air at 30°C can hold more than 30 grams per cubic meter of water vapor (actually, 42g/m³). Conversely, if we decrease the temperature of saturated air from 24°C (which contains 30 g/m³ of water vapor) to 12°C (which has a water vapor capacity of only 14 g/m³), some 16 grams of the water vapor will condense out of the air because of the reduced capacity.

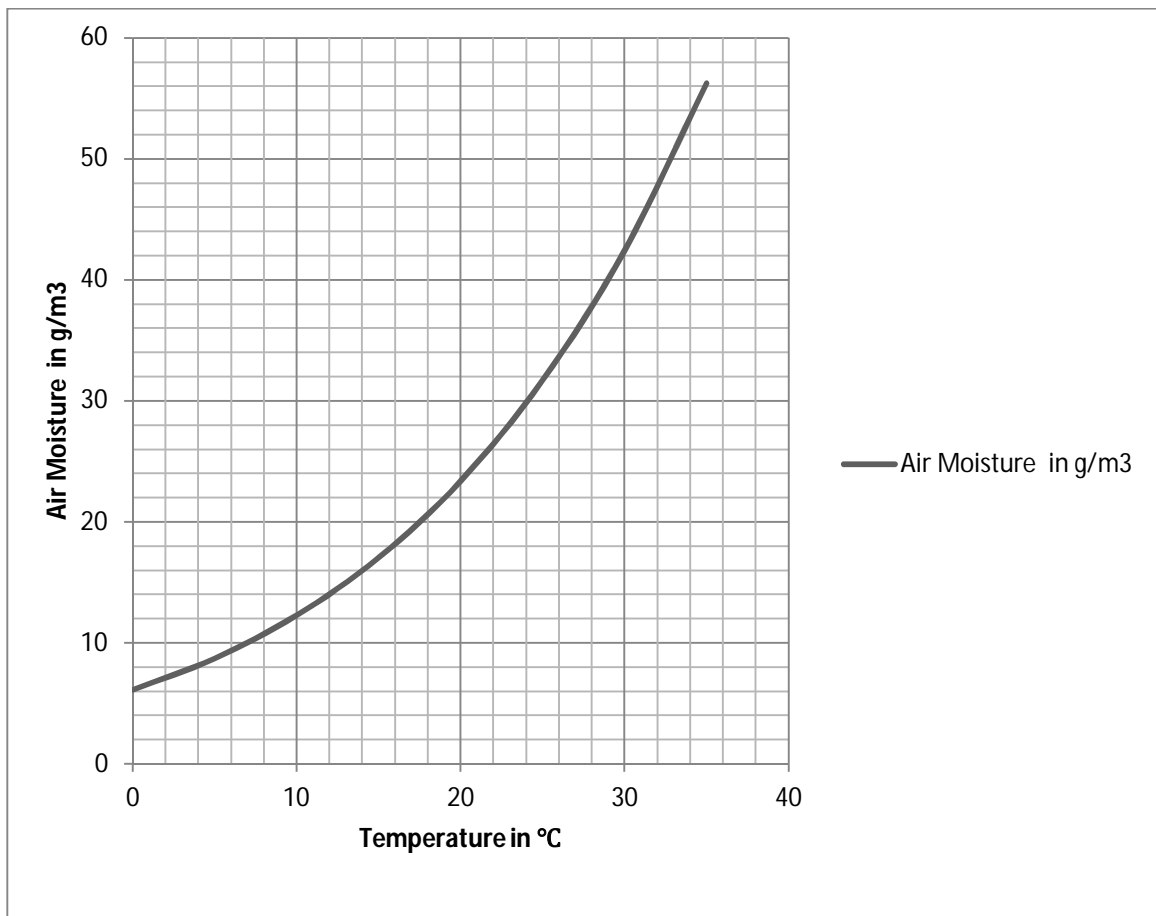

Figure 4-10: Maximum amount of water vapor that can be contained in a cubic meter of air over a wide range of temperatures.

(b) Sensitivity Analysis for Bed Material.

An experiment has been conducted in Alexandria, Egypt by M.H. Mohamed [22] to determine amount of water from humid air using desiccant material. The experiment used two alternative bed materials to evaluate the effect of the two.

Table 4-4: Bed Materials [22]

No	Parameter	Bed material	
		Sand bed	Clothe bed
1	thermal capacity	98kj/(m ² ,°C)	41kj/(m ² ,°C)
2	the rate of increasing of bed surface temperature	77°C	85.9°C
3	Evaluation on thermal analysis	High	Low
4	the vapor pressure difference	smaller	larger
5	Maximum productivity	565 g/(m ² ,h) at 14PM	640 g/(m ² ,h) at solar noon time
6	average system productivity	324 g/(m ² ,h)	374 g/(m ² ,h)
7	Evaluation on average productivity		By 13.4% larger as compared to sand bed
8	Collector efficiency	Less efficient by 15.4%.	better
9	The hourly collector efficiency, during the solar intensity decreases afternoon	Increase sharply	Decrease sharply
10	regeneration characteristic	low	better
11	By material availability	available and free of charge	Cost incurred

We could theoretically conclude that cloth bed material is efficient in water production from humid air using wet desiccant.

Vapor pressure difference in cloth bed and sand bed is shown in figure 4-11.

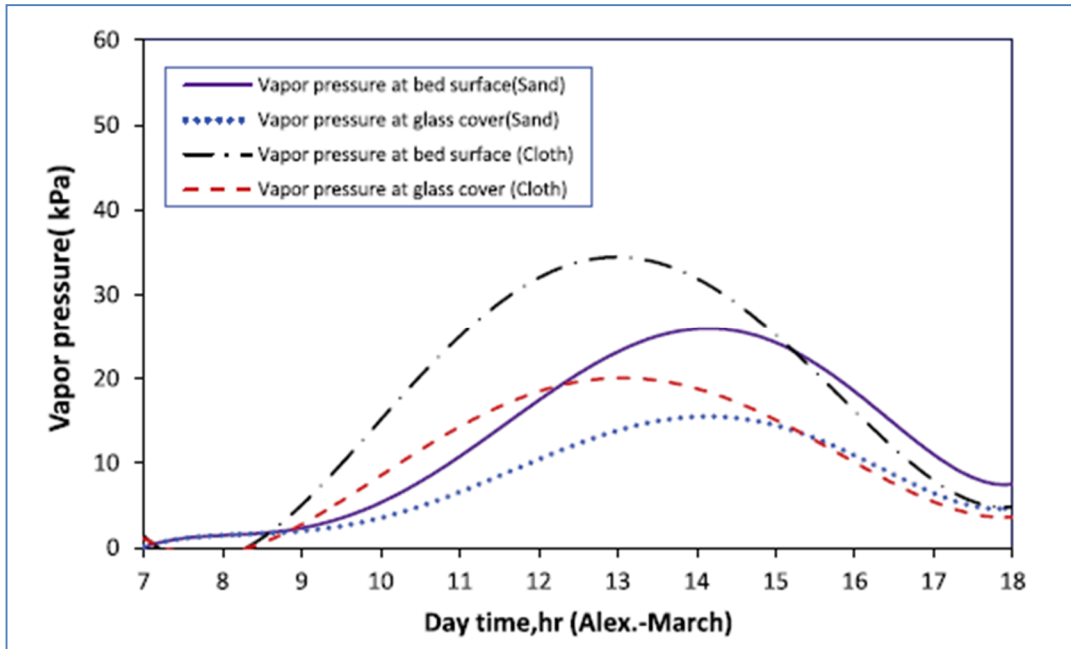

Figure 4-11: Hourly system vapor pressures for different bed materials [22].

Cloth bed productivity quickly increase until it reaches maximum of 640 g/(m²,h) at solar noon time by the same activity it decrease speedily, whereas sand bed slightly experience the same and it reaches the maximum at 565 g/(m²,h) at 14PM. This illustrated in the figure 4-12.

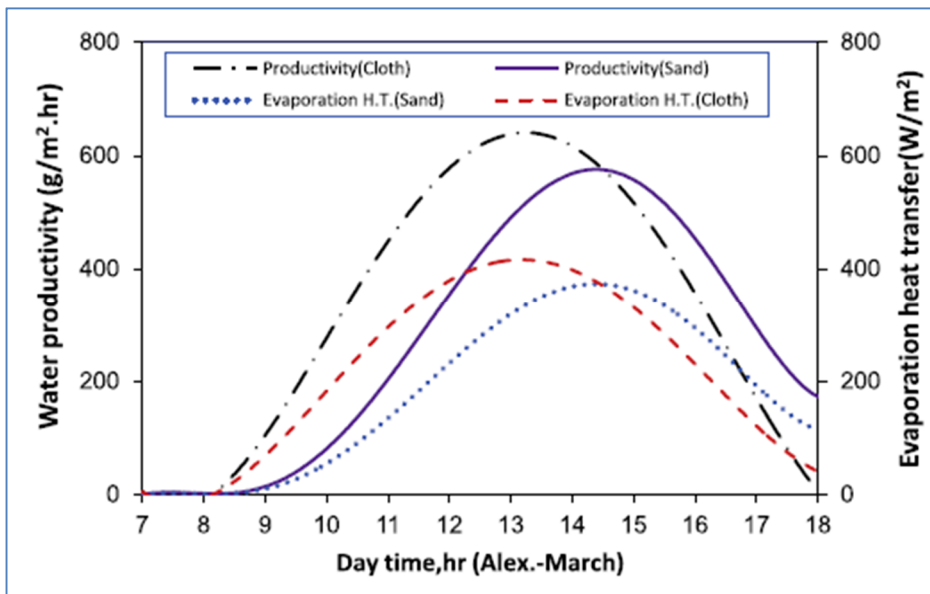

Figure 4-12: Hourly system productivity and evaporation for different bed materials [22].

Hourly collector efficiency of sand bed is increase with decreased solar intensity during afternoon is seen in figure 4-13.

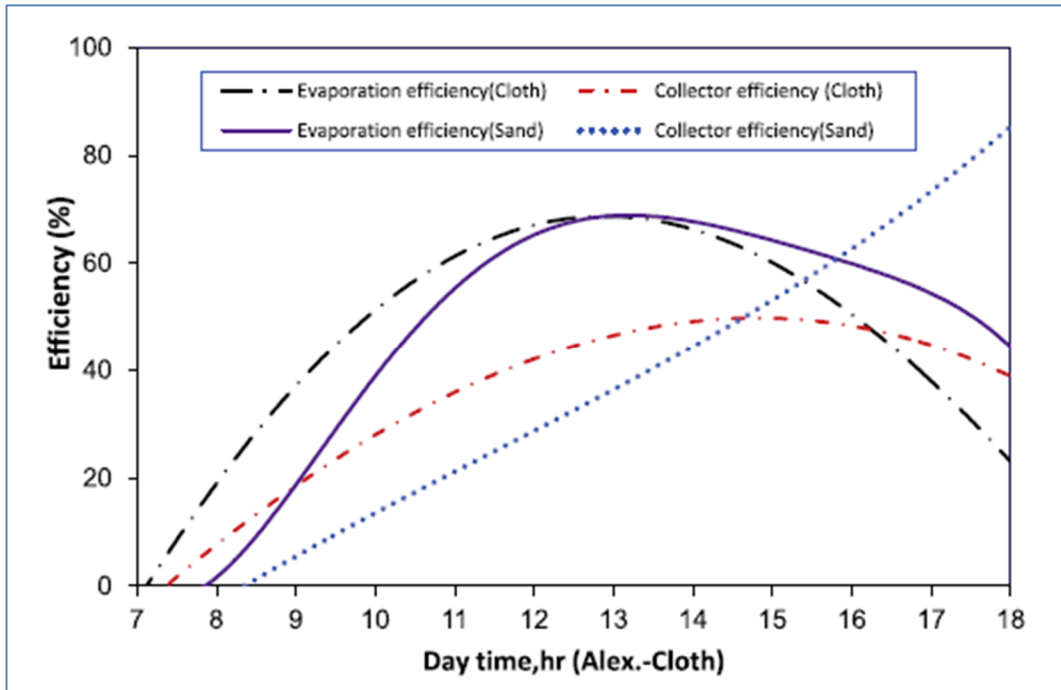

Figure 4-13: Hourly system efficiencies for different bed materials [22].

(c) Effect of Desiccant Concentration

As one of research paper conducted by Manoj Kumar and Avadhesh Yadav [61], experiment has been done based on various concentration of CaCl_2 in vermiculite/saw wood and tested to quantify best water production rate. Among the six tests, the maximum adsorption was achieved with sample-6 (0.1 kg/h) because it has the maximum concentration of CaCl_2 which leads to adsorption of more moisture as compared to the other samples. Therefore, generating maximum amount of water The maximum generation of water by samples 1, 2, 3, 4, 5, and 6 are 110, 125, 145, 160, 180 and 195 ml/kg/day respectively as shown in Figure 4-14.

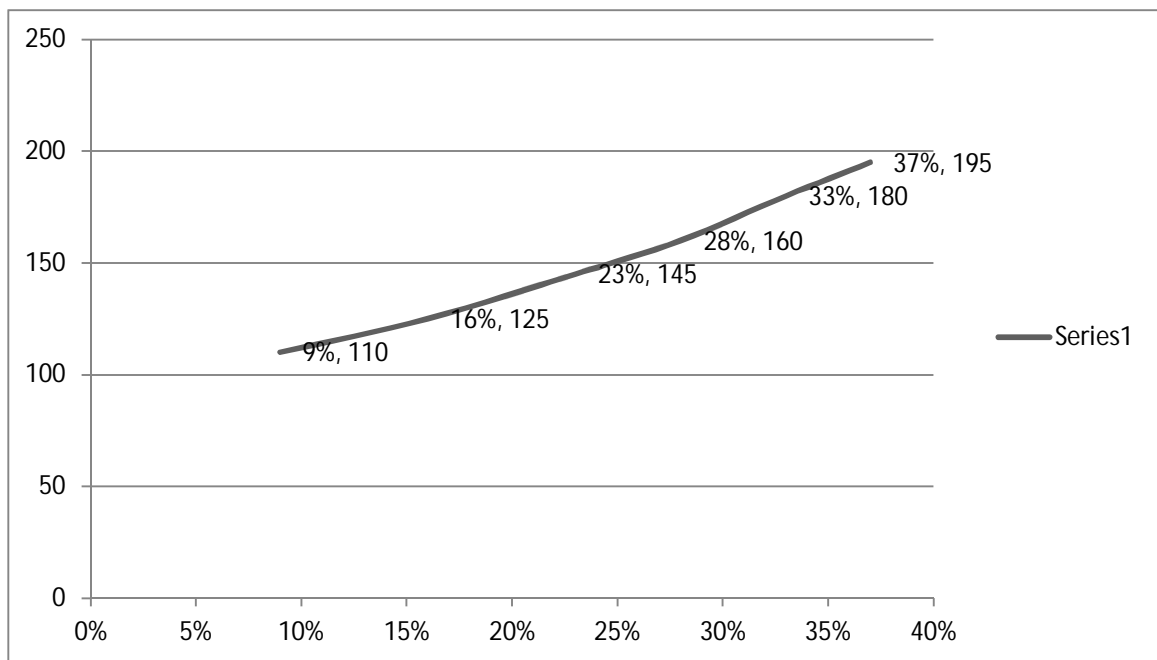

Figure 4-14: CaCl_2 concentration effect

4.3.6 Thermal theoretical system efficiency

As it was formulated theoretically by A. E. KABEEL [44], operation system efficiency is represented by figure 4-15 indicated that as solar radiation decreases system efficiency also declined in the same trend. This process indicated in figure 4-15.

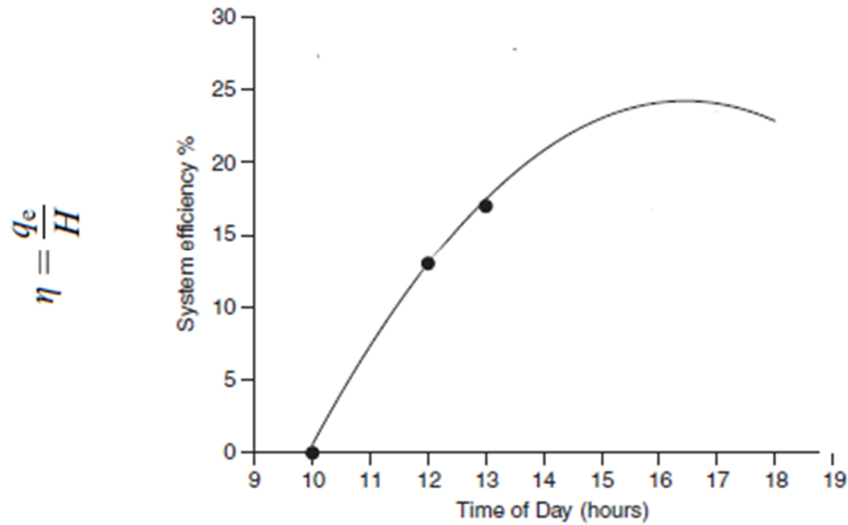

Figure 4-15: Typical System efficiency [44]

4.3.7 Comparison of experiment and Analytical Results

No	Test Parameter	Test Result	Analytical Result
1	Dew point temperature (°C)	30	23.26
2	Bed temperature (°C)	70	89.1
3	Target output	very promising indication but not quantify	1 liter
4	Glass cover temperature reached (°C)	30	60

Table 4-5: Test Comparison

Chapter 5 : CONCLUSION & RECOMMENDATION

5.1 Concluding Discussion

The study of water extraction from humid air using different techniques by researchers has been undertaken to identify the potential of humidity and solar energy in various places specifically in semi-arid zones where there are a critical potable water shortages and renewable solar energy potentials are available.

In this thesis the use of mixture of sand bed and calcium chloride as a composite material and clear solar glass as a vapor condenser for their application in drinking water harnessing from the air humidity has been evaluated. The main findings of the research are summarized as follows.

- 1) The main consideration about the design questions in cost minimization of each components (sand bed, condenser & air entry window) as suitable option for large scale humidity harnessing .Such caution and addressing affordability from end user. Easiness for mobilization and some safety features were also considered;
- 2) The assumptions for the vapor transport and evaporation from sand bed as well as the experiments indicated that the use of gasket between mating part can result in a considerable vapor loss rate. Especially during day time, the prototype should therefore be test for leakage proof.
- 3) Literature research suggests that the Solar Glass Sand bed box System (SGSS) with the required performances are not yet commercially available in the market. Yet, 25-30% calcium chloride and 25 degree of inclination angle have a promising result of $1l/m^2/day$. The performance of this existing prototype can be improved when adding fan and solar panel.

Basic requirements of the technology were:

The prototype of the technology was designed and manufactured which consisted of a steel rectangular boxes having ash box for insulation and sand box hosting sand and calcium chloride mixtures and double triangular shape solar glass box assembled and fixed on steel stand. During the night time two windows of the prototype were left opened. While air was passed over the composite desiccant material there is a chance to capture moisture from the air and dry air is out via the other window. Next cycle started

during day time two windows were closed and double solar glass was exposed to sun light over the day. The experiment was done at Adama wind farm electrical station-1.

By observation and analysis it is concluded that moisture in the humid air can be condensed successfully using above designed set up even though there is some difference between the calculated and actual water obtained, this system is useful for rural areas where water scarcity is critical.

Atmospheric water generator could be our main focus due to it has the following main advantages:

- Atmospheric water is an alternative natural resource to ground or surface water sources which is untapped currently in Ethiopia
- Atmospheric water is precipitation independent source.
- Atmospheric water is free from fecal contamination as well as natural & manmade contaminations which ground water suffers from. Atmospheric pollution is easily removable with modern technology.
- House hold capacity atmospheric water generators do not require extensive backend infrastructure which is required for piped water supply.
- Atmospheric water generator can be deployed directly to premises.

In conclusion it can be said, that sand bed assisted humidity harvesting is a very promising and its component can be further made from local materials like bamboo and clay so that it is economical way for the generation of drinking water. Yet, the development of the required parts on industrial scale is not seen, so that the actual implementation is not feasible at the moment, but can be expected to be a working business case and thus find real life application in a near future

5.2 Recommendation for Future Work

From the experiments conducted in Adama to test the potential of water extraction from humid air there is a promising result. But, the design can be improved by adding air pump and solar panel as this can generate an electric light for the system to generate potable water and also used as a source of light. Or encouraging the government or NGOS to assemble AWG and distribute for sever water shortage areas.

Most semi-arid area in Ethiopia has promising humidity and a good potential of solar energy to generate electricity for solar panel where local community far from national grid. For comparison let's see Model No. HR-90HK, air water generator of one company.

Table 5-1: Possibility of importing AWG and potential of usage.

No	parameter	Yabello Climate data	Model No. <u>HR-90HK</u> Minimum requirement to generate potable water
		47 (min)	35(min)
1	Working humidity (%):	74 (max)	95(max)
2	Energy required for condensation (W)	-	300
3	Thermal energy for heating during evaporation (W)	-	500
3	Output	-	30 Liters/day generated at 30°C & 80%RH
4	Technology used here is refrigerator system		Gas used:R134a 'a' stands for the product not being toxic or harmful.

Chapter 6 : Appendix

6.1 AWG Suppliers List

Worldwide atmospheric water generator is available by several brands. Here are supplier links of 78 brands.

1. [a2wh.com \(air to water harvest\)](http://a2wh.com), USA
2. [Adder Hill UK](#), UK
3. [Air2Water LLC](#), USA
4. [Air to Water Technologies, Inc.](#), USA
5. [Air watergreen AB](#), Sweden
6. [Air water Shop Ltd](#), UK
7. [Airwaterex Ltd](#), Cyprus
8. [Air Water World USA, Inc.](#), USA
9. [Akash Ganga \(Clean Water Generator Pvt. Ltd.\)](#), India
10. [Alchemy Sun and Water](#), USA
11. [Ambient Water, Inc.](#), USA [**Stock symbol: AWGI**]
12. [Aqua Sciences, Inc.](#), USA
13. [Aqua Solutions Corp.](#), USA
14. [Aquaer Generators S.L.](#), Spain
15. [Aquavolve, LLC](#), USA
16. [Ardor Marketing Pte Ltd](#), Singapore
17. [AT Company](#), Korea
18. [Atlantis Solar and Wind LLC](#), USA
19. [Atmospheric Water Solutions](#), USA
20. [Atmospheric Water Supply, LLC](#), USA
21. [AtmoWater Inc. \(Ser-Manukyan Family Holdings\)](#), USA
22. [AWG Technology, Inc.](#), USA
23. [Bestway \(Shanghai\) Technology Co., Ltd](#), China
24. [Blanca GIS \(Pty\) Ltd](#), South Africa
25. [Canadian Dew Technologies Inc.](#), Canada

26. [CYBEXNT Technology S. L. U.](#), Spain
27. [Desert Dew](#), United Arab Emirates
28. [DewPoint Systems](#), USA
29. [Drinkable Air, Inc.](#), USA
30. [Drought Masters](#), USA
31. [Dutch Rainmaker](#), Netherlands
32. [EcoloBlue, Inc.](#), USA
33. [Element Four Technologies Inc.](#), Canada
34. [Eole Water S.A.S.](#), France
35. [EuroSport Active World Corp \(EAWC\) Technologies](#), USA [**Stock symbol: EAWD**]
36. [Excel Water Technology, Inc.](#), USA
37. [Global Site Solutions Inc.](#), Canada
38. [GOODWATER Beteiligungs GmbH](#), Austria
39. [Hendrx](#), China
40. [HidroAir System, s.l.](#), Spain
41. [Hottime Technology Co. Ltd](#), China
42. [Hyflux Consumer](#), Singapore [**Stock information**]
43. [Infinite Water, Inc.](#), USA
44. [Island Sky Corporation](#), USA (and Australia) [**ASX: PAW**]
45. [Konia Australia Pty Ltd.](#), Australia
46. [Liquid of Life](#), UAE
47. [MSP Technology.com, LLC](#), USA
48. [One World Partners LLC](#), USA
49. [Pacific AirWell](#), USA
50. [Proficient Machine and Automation](#), USA
51. [Quest Water Solutions, Inc.](#), Canada
52. [RainInABox.org \(Rocillo Innovative Technologies, Inc.\)](#), USA
53. [Ray Agua Universal](#), Spain

54. [Saison Technocom Pvt. Ltd](#), India
55. [SEAS SA](#), Switzerland
56. [SeaStream General Trading LLC](#), UAE
57. [Shanghai Lonsid Import & Export Co., Ltd.](#), China
58. [Shenzhen FND Air & Water Technology Development Co., Ltd.](#),
China
59. [SkyH2O, Inc.](#), USA
60. [Skysource.org](#), USA
61. [Sky spring](#), UK
62. [Skywell, LLC](#), USA
63. [SunToWater Technologies, LLC](#), USA
64. [UAE Water](#), United Arab Emirates
65. [Untapped Water Systems](#), Taiwan
66. [Vitality Vector, BV](#), Netherlands
67. [Watair Inc.](#), USA
68. [Water From Air](#), South Africa
69. [Water Generating Systems, LLC](#), USA
70. [Water Technologies International, Inc.](#), USA [**Stock: WTII**]
71. [Water World Solution](#), France
72. [Watergenics Inc.](#), Canada
73. [WaterMaker \(India\) Pvt. Ltd.](#), India
74. [WaterMicronWorld Ltd](#), Thailand
75. [Water-Gen Ltd.](#), Israel
76. [World Environmental Solutions Pty Limited](#), Australia
77. [Yueqing Kemao Electric Co., Ltd](#), China
78. [Zero Mass Water, Inc.](#), USA

There are many brands of atmospheric water generators (AWG) in the world market ([65]).In producing the machine U.S.A is leading. Here is the rest in the table below.

Table 6-1: AWG Supplies List Summary [66]

Country - Number of Suppliers
USA - 35
China - 6
Canada - 5
United Arab Emirates - 4
Spain - 4
India - 3
United Kingdom - 3
Australia - 2
France - 2
Netherlands - 2
Singapore - 2
South Africa - 2
Austria - 1
Cyprus - 1
Israel - 1
Korea - 1
Sweden - 1
Switzerland - 1
Taiwan - 1
Thailand - 1
Total - <u>78</u>

6.2 Dewpoint Calculator Software [67]

Dew Point Calculator

This calculator estimates the temperature to which air must be cooled given a certain pressure and water-vapor content in order to become saturated with water vapor, and form dew. It is closely related to relative humidity, both of which can be used along with air temperature to estimate heat index.

Given **any two** of the three variables (air temperature, dew point temperature, and relative humidity), the calculator can provide the value for the third.

Result

Dew Point Temperature: **69.1°F or 20.6°C or 293.8K**

Air Temperature	<input type="text" value="26.8"/>	<input type="text" value="celsius"/>
Dew Point Temperature	<input type="text"/>	<input type="text" value="celsius"/>
Relative Humidity	<input type="text" value="69"/>	<input style="text-align: right; font-size: small; font-weight: normal; border: none; padding: 0 5px;" type="text" value="%"/>

Calculate 

6.3 Types of air

1. Humid Air = a mixture of air and water vapor; the amount of water vapor in the air is called humidity. The amount of water vapor the air can hold depends on the temperature of the air.
2. **Warm** air can hold more water vapor, while cold air cannot hold as much.
3. **Moisture air**: under standard Atmospheric pressure, the maximum water content of one cubic air is varies as ambient temperature changes. It is indicated in the table below.

Table 6-2 : Moisture Content in one cubic air base on ambient temperature at standard atmospheric pressure

T _a (°C)	-30	-20	-10	-5	0	5	10	15	20	25	30	35
Moisture (g/m ³)	0.51	1.25	2.86	4.21	6.11	8.72	12.27	17.04	23.37	31.67	42.43	56.23

Reference used in table 6-2 was taken from Fujian Xinquan Air Drinking Water Technology Co., Ltd

Amount of water (in L) present in 1m³ of air for different humidity and temperature conditions:

Sample Calculations: (For atmospheric temperature 25°C and relative humidity 35%)

Saturation Pressure of water vapour (P_s) at 25°C is obtained from steam table as **0.03167** bar.

$$\checkmark P_w = RH * P_s = 35\% * 0.03167 \text{ bar} = \mathbf{0.0110845 \text{ bar}}$$

$$\checkmark \text{ Humidity Ratio, } \phi = 0.622 \frac{P_w}{P_a - P_w} = 0.622 * \frac{0.0110845}{1.01325 - 0.0110845} = \mathbf{0.006879661}$$

Humidity ratio gives the amount of water (in m³) present in 1m³ of air. Also we know that 1m³ is equal to 1000 litres. Thus multiplying humidity ratio by 1000 gives the maximum amount of water (in litres) that is present in 1m³ of air.

✓ Therefore amount of water (in litres) present in 1m³ of atmospheric air.

$$\text{Humidity ratio} \times 1000$$

$$0.006879661 \times 1000 = \mathbf{6.879661 \text{ litres}}$$

6.4 Definition of key concepts used in this thesis

- **Absorption (of water vapor)** - retention (of water vapor) by penetration into the bulk of a material
- **Humidity** is presence of water vapor in air or other gas.
- **Hygrometer** is any instrument for measuring humidity
- **Partial pressure (of water vapor)** - The part of the overall pressure exerted by the water vapor component in a gas.
- **Condensation** is change of phase of vapor into liquid by extracting heat from the vapor
- **Climate** is for a specified region; the statistical collection of weather conditions (temperature, precipitation, humidity, pressure, sunshine, wind velocity) during a specified time period; Compare definition for 'Weather'.
- **Dehumidification** is removal of water vapor from air.
- **Dewpoint temperature** is temperature at which water vapor has reached the saturation point (100% relative humidity); Note that condensation occurs only if the vapor is cooled *below* the dew-point.
- **Drybulb temperature** is air temperature as measured by an ordinary thermometer.
- **Fog** is airborne liquid water droplets formed by condensation of water vapor.
- **Moisture** is water vapor; small quantity of water in liquid or vapor form but not bulk water or flowing water.
- **Adsorption** is retention (of water vapor) as a surface layer on a material such as silica gel, Zeolite, clay, calcium chloride, etc...
- **Desorption** is a process cycle in which a very hot and humid air stream produces regeneration of the adsorption material by providing heat to the system.
- **R134a (A: Azeotropic mixtures.** Although it contains two or more **refrigerants**, at a certain pressure an **azeotropic** mixture evaporates and condenses at a constant temperature.
- **Desiccants** are the substances that absorb water-vapour molecules from the air via an adsorptive process. Adsorption refers to a desiccant that does not change phase as it collects airborne moisture [30].

6.5 Bibliography

- [1] Krishnamurthy L., Mainassara Abdou Zaman-Allah, Purushothaman R., Mohammed Irshad Ahmed and V. Vadez, *Plant Biomass Productivity Under Abiotic Stresses in SAT Agriculture*. India, India: Research Gate, September 2011.
- [2] [Online]. <http://www.fao.org/sd/EIdirect/climate/EIsp0002.htm>
- [3] Seyoum Leta Thewodros Bekele, "Water Supply and Health: Drinking water and Sanitation Coverage in Ethiopia 1990 - 2015 Review," vol. I, no. 1, May-June- 2016.
- [4] WaterAid, "Water: At What Cost? The State of the World's Water 2016," 2016.
- [5] Tenna Shiterek, "Ethiopia Country Report," May 2012.
- [6] A. Seifu, M. Hoogland, A. de Vries R. Lasage, "Report on general characteristics of the Borana zone, Ethiopia," Addis Ababa, Report R-10/03, 2010.
- [7] and D. Beysens I. Milimouk, "THE CASE FOR ALTERNATIVE FRESH WATER SOURCES," Pessac, France, 2000.
- [8] [Online].
https://commons.wikimedia.org/wiki/File:Ethiopia_map_of_K%C3%B6ppen_climate_classification.svg
- [9] Sankha dip Das (Dr.), "Balance of System for Solar PV: Part II Solar Water Pumps," P006, p. 1, 2013.
- [10] SunToWater. suntowater.com>archive. [Online]. **Error! Hyperlink reference not valid.**
- [11] Chuan Lia PhD Student, "Case Study: Borana, Ethiopia," Yabello, March 2014.
- [12] Samuel Tesema, Getachew Bekele, "Resource assessment and optimization study of efficient type hybrid power system for electrification of Rural District in Ethiopia," *International Journal of Energy and Power Engineering*, 2015.
- [13] A. Russel-Smith, "The environment of the Ethiopian Rift Valley compared to other areas of Africa," Addis Ababa, Ethiopia,.

- [14] Rasmus Fensholt, Stéphanie Horion, Torbern Tagesson and Andrea Ehammer, "Assessment of Vegetation Trends in Drylands from Time Series of Earth Observation Data," in *Remote Sensing Time Series, Remote Sensing and Digital Image Processing*. Switzerland: Springer International Publishing Switzerland, 2015, ch. 8, pp. 159 -182.
- [15] [Online]. <https://www.researchgate.net/publication/306167024>
- [16] S. Tapuchi, A. Kuperman, S. Makarenko, Y. Horen and M. Malinkovski, "Obtaining fresh water from atmosphere using electrostatic precipitation: theory, efficiency and limitations," *Applied Energy*, p. 11, 2010.
- [17] Ben Gido, Eran Friedler, David M. Broday, "Assessment of atmospheric moisture harvesting by direct cooling," vol. 182, pp. 156–162, 2016. [Online]. <http://dx.doi.org/10.1016/j.atmosres.2016.07.029>
- [18] Jeremy K. Domen • William T. Stringfellow, Mary Kay Camarillo • Shelly Gulati, "Fog water as an alternative and sustainable water resource," no. 16, 2014.
- [19] erik, "Dew Harvesting as a means to get clean drinking water," *Articles water*, pp. 1-3, May 21, 2014.
- [20] [Online]. <http://inspiringfuture.org/wordpress/2014/05/21/dew-harvesting-as-a-means-to-get-clean-potable-water/>
- [21] "Liquid-Desiccant Vapor Separation Reduces the Energy Requirements of Atmospheric Moisture Harvesting," vol. 50, 2016.
- [22] G.E. William, M. Fatouh M.H. Mohamed, "Solar energy utilization in water production from humid air," *Solar Energy*, vol. 148, pp. 98 - 109, March 2017.
- [23] Vincenzo Gentile¹, Marco Simonetti¹, Pietro Finocchiaro², Gian Vincenzo Fracastoro¹, "Water production from the atmosphere in arid climates using low grade solar heat," 2017.
- [24] Girja Sharan, "Harvesting Dew with Radiation Cooled Condensers to Supplement Drinking Water Supply in Semi-arid Coastal Northwest India," *International Journal for Service Learning in Engineering*, vol. 6, no. 1, pp. 130 -150, Spring 2011.
- [25] Aditya Nandy, Sharmi Saha, Souradeep Ganguly, Sharmistha Chattopadhyay,

- "A Project on Atmospheric Water Generator with the Concept of Peltier Effect," *International Journal of Advanced Computer Research*, vol. 4, no. 15, June 15 June-2014.
- [26] Dr.Sankha dip Das, "Solar Atmospheric Water Generator – A solution for drinking water problems everywhere," *Solar Atmospheric Water Generator – A solution for drinking water problems everywhere, Urrjaa, P017*, pp. 1-2, 2013.
- [27] Magrini A.a, Cattani L.b, Cartesegna M.c, Magnani L.a, "Production of water from the air: the environmental sustainability of air-conditioning systems through a more intelligent use of resources.The advantages of an integrated system," , University of Pavia, Italy, 2015. [Online]. <http://creativecommons.org/licenses/by-nc-nd/4.0/>
- [28] Daniel Bergmair, *Design of a system for humidity harvesting using water vapor selective membranes*. Eindhoven: GVO drukkers & vormgevers B.V., 2015.
- [29] a chemist at the University of California, Berkeley Omar Yaghi. (2017, April) Science. [Online]. <http://www.sciencemag.org/news/2017/04/new-solar-powered-device-can-pull-water-straight-desert-air>
- [30] Atul Ekad, Tejas Pawar, Nitish Yeole, Ajinkya Taksale, Aanand Gajjar, "Solar Powered Atmospheric Water Generator and overview on AWG technologies," *IJRSET*, vol. 7, no. 1, p. 9, January 2018.
- [31] sciencedaily.com chemistry.about.com. why does salt absorb moisture? [Online]. <https://www.reference.com>
- [32] Manoj Kumar & Avadhesh Yadav, "Comparative study of solar-powered water production from atmospheric air using different desiccant materials," *Renewable Energy*, vol. 7, p. 10, December 2017. [Online]. <https://doi.org/10.1080/19397038.2016.1200692>
- [33] M.H. Mohamed, G.E. William, M. Fatouh, "Solar energy utilization in water production from humid air," *Solar Energy*, pp. 98-109, April 1,2017.
- [34] Manoj Kumar and Avadhesh Yadav, "Composite desiccant material “CaCl₂/Vermiculite/Saw wood”:a new material for fresh water production from atmospheric air," *Appl Water Science*, pp. 1-9, 2016.
- [35] Shobhit Srivastava and Avadhesh Yadav, "Economic analysis of water production from atmospheric air using Scheffler reflector," *Vol.:(0112*

33456789), p. 10, 22 November 2018.

- [36] [Online]. <https://www.infiniumglobalresearch.com/reports/sample-request/1086>
- [37] (2005) www.konia.com.au. [Online]. http://konia.com.au/wp-content/uploads/2014/11/Konia_Corporate_Profile.pdf
- [38] Thomas D. Merritt, "Multipurpose adiabatic potable water production apparatus and method," USA,FLORIDA, US 7121101 B2, Oct 17, 2006.
- [39] TSEGAZAB GEBRELIBANOS GEBREMEDHIN, "WATER HARVESTING SYSTEMS," , Mekelle, September 2015.
- [40] Mohamad Kharseh, Energy Balance of Solar Collector, 2017, No.
- [41] A. E. Kabeel, "APPLICATION OF SANDY BED SOLAR COLLECTOR SYSTEM FOR EXTRACTION OF WATER FROM AIR," , Eighth International Water Technology Conference, IWTC8 2004, Alexandria, Egypt, 2004, pp. 1707 - 1720.
- [42] N. Audah, N. Ghaddar, K. Ghali, "Optimized solar-powered liquid desiccant system to supply building fresh," *Applied Energy*, pp. 1-3, 2016. [Online]. <http://aip.scitation.org/toc/apc/1712/1>
- [43] Ahmed M. Hamed, Ayman A. Aly, El-Shafei B. Zeidan, "Application of Solar Energy for Recovery of Water from Atmospheric Air in Climatic Zones of Saudi Arabia," *Scientific Research*, vol. 2, January 2011.
- [44] A.E.Kabeel, "Application of sandy bed solar collector system for extraction of water from air," in *Eighth international water technology conferance* , Egypt, 2004.
- [45] Manoj Kumar, Avadhesh Yadav and Neeraj Mehla, "Water generation from atmospheric air by using different composite desiccant materials," 2017. [Online]. <http://www.tandfonline.com/loi/taen20>
- [46] Abdisa T1, Wubishet Z2* and Etsay K1, "Study on Major Constraints of Camel Production, Management and Their Impacts in and Around Yabello District, Oromia Regional State, Southern Ethiopia," *Dairy and Veterinary Sciences*, vol. 3, no. 1, August 16, 2017.

- [47] Dandesa T1, 2*, Korecha D1, Nigatu L2 and Cheneka BR3, "Assessment of Climatic Variability and Development of Localized Climate Prediction Method for Livestock Production in Borana Area, Southern Ethiopia," vol. 13, no. 3, May 2017.
- [48] Massimiliano Fazzini, Carlo Bisci, and Paolo Billi, "The Climate of Ethiopia," October 2016.
- [49] Eyaya Belay, "MODELING SITE SUITABILITY FOR WIND FARM USING REMOTE SENSING AND GIS: THE CASE OF ADAMA WOREDA," Addis Ababa University, DEPARTMENT OF EARTH SCIENCES GIS AND REMOTE SENSING STREAM, Addis Ababa , Master Thesis 2009.
- [50] [Online]. <https://www.worldweatheronline.com/adama-weather-history/et.aspx>
- [51] Sri Suryaningsiha and Otong Nurhilalb, "Optimal Design of an Atmospheric Water Generator (AWG) Based on Thermo-Electric Cooler (TEC) for Drought in Rural Area," *Rightslink*, 2016. [Online]. <http://aip.scitation.org/toc/apc/1712/1>
- [52] Alexander Bolonkin, "AB Method of Irrigation without Water(Closed-loop water cycle)," *Article Irrigation after Joseph and my corr 11 14 07*.
- [53] [Online]. http://www.solarelectricityhandbook.com/solar_irradiance
- [54] Erik Boije & Gustaf Eskhult, "With a few liters of clean drinking water :A Cost Benefit Analysis of the socio-economic effects from implementing new clean drinking water technologies in rural India," *SLU*, 2014.
- [55] Fabio Struckmann, "Analysis of a Flat-plate Solar Collector," Dept. of Energy Sciences, Faculty of Engineering, Lund, Sweden, 2008 MVK160 Heat and Mass Transport May 08, 2008.
- [56] OxyChem's calcium chloride products. www.oxycalciumchloride.com. [Online]. www.oxycalciumchloride.com
- [57] R. Lalitha Priya, Salim Subi, B. Vaishnu and K. R. M. Vijaya Chandrakala, "Study on Characterization of River Sand as Heat Storage Medium," vol. 9(30), August 2016.
- [58] Wael M. El-Maghlany, "An approach to optimization of double slope solar still geometry for maximum collected solar energy," *Alexandria Engineering*

Journal, June 2015.

- [59] Ramadhani Bakari, Rwaichi J. A. Minja, and Karoli N. Njau, "Effect of Glass Thickness on Performance of Flat Plate Solar Collectors for Fruits Drying," *Journal of Energy*, vol. 2014, p. 8, March 2014.
- [60] Maatouk Khoukhi, Shigenao Maruyama, "Temperature and Heat Flux Distributions through Single and Double Window Glazing Nongray Calculation," *Smart Grid and Renewable Energy*, no. 2, pp. 21 -26, February 2011.
- [61] Manoj Kumar and Avadhesh Yadav, "Composite desiccant material "CaCl₂/Vermiculite/Saw wood": a new material for fresh water production from atmospheric air," *a new material for fresh water production from atmospheric air*, pp. 1-9, 2016.
- [62] Professor Bo Hellström, "POTABLE WATER EXTRACTED FROM THE AIR REPORT ON LABORATORY EXPERIMENTS," *Journal of Hydrology* 9, vol. 9, p. 19, 1969.
- [63] Abd elnaby Kabeel, "The performance of Different Sand Beds Solar Stills," 22 September 2014.
- [64] S. Kumar and S. C. Mullick, "Wind heat transfer coefficient in solar collectors in outdoor conditions," *Solar Energy*, vol. 84, no. 6, pp. 956–963, 2010.
- [65] (2017, May) Atmospheric Water Generator or Water-from-Air Machine. [Online]. <http://www.atmoswater.com/manufacturers-and-suppliers-of-atmospheric-water-generators--water-from-air-machines.html>
- [66] [Online]. <http://www.atmoswater.com/manufacturers-and-suppliers-of-atmospheric-water-generators--water-from-air-machines.html>.
- [67] [Online]. <https://www.calculator.net/dew-point-calculator.html?airtemperature=26.8&airtemperatureunit=celsius&dewpoint=&dewpointunit=celsius&humidity=69&x=58&y=19>
- [68] Jenny Lindblom and Bo Nordell, "Underground condensation of humid air for drinking water," *Since direct*, 16 February 2006.
- [69] A. Kuperman, S. Makarenko, Y. Horen and M. Malinkovski S. Tapuchi, "Obtaining fresh water from atmosphere using electrostatic precipitation,"

2010.

- [70] P. Franceschetti and F. Gonella, "New Solar Still with the Suction of Wet Air," *Journal of Fundamentals of Renewable Energy and Applications*, vol. Vol. 2 , p. 5, 2012.
- [71] A. E. Kabeel, EShafei B. Ahmed M. Hamed, "A TECHNICAL REVIEW ON THE EXTRACTION OF WATER FROM ATMOSPHERIC AIR IN ARID ZONES," *JP Journal of Heat and Mass Transfer*, vol. Volume 4, pp. Pages 213-228., 2010.
- [72] ROLAND V. WAHLGREN, "ATMOSPHERIC WATER VAPOUR PROCESSOR DESIGNS," *2000 Elsevier Science Ltd*, vol. 35, p. 22, 2001.
- [73] Vali Alipour and Leila Rezaei Amir Hossein Mahvi, "ATMOSPHERIC MOISTURE CONDENSATION TO WATER RECOVERY BY HOME AIR CONDITIONERS," *American Journal of Applied Sciences*, no. 10 (8): 917-923, pp. 917-923, 2013.
- [74] Samir Tushar, Saurabh Pal, Shoumik Lodh, Shashank Tiwari, Prof. R. S. Desai Anurag Tripathi, "Atmospheric Water Generator," *International Journal of Enhanced Research in Science, Technology & Engineering*, vol. Vol. 5 , no. Issue 4, April-2016.
- [75] Sankara Narayanan.G and Pavithra S. Anbarasu.T, "Design And Development Of Cooling Condensation Process By Using Humidity In The Air," in *Thermal Energy and Environment (INCOTEE 2011)*, 09 June 2016.
- [76] Ember M. Morrissey, Sasha C. Reed, Bruce A. Hungate and Egbert Schwartz Theresa A. McHugh, "Water from air: an overlooked source of moisture in arid and semiarid regions," Northern Arizona, Published: 08 September 2015.
- [77] Avinash Chaudhary & Avadhesh Yadav Amit Kumar, "The Regeneration of Various Solid Desiccants by Using a Parabolic Dish Collector and Adsorption Rate: An Experimental Investigation," *International Journal of Green Energy*, vol. 11, pp. 936–953, 2014.
- [78] Abiti Getaneh, "Ethiopian Water Resources Potential & Development of Ethiopia," Netherland, 2011.
- [79] Stuart Freedman – Panos, "Fresh Water Technology Reviews," in *Ten Frontier*

Technologies for International Development Fresh Water. Dwarka, pp. 88-101.

- [80] Tenna Shitarek, "Ethiopia Country Report," May 2012.
- [81] P. GANDHIDASAN and H.I. ABUALHAMAYEL, "WATER RECOVERY FROM THE ATMOSPHERE," *WREC*, pp. 1-4, 1996.
- [82] A.M.K. El-Ghonemy, "Fresh water production from/by atmospheric air for arid regions,using solar energy: Review," *Renewable and Sustainable Energy Reviews*, no. 16, p. 1, June 2012.
- [83] Kingdom of Saudi Arabia Al Madinah Al Munawarah, "Solar Water Condensation Using Thermoelectric Coolers," *International Journal of Water Resources and Arid Environments*, pp. 142-145, 2011.
- [84] A.M.K. El-Ghonemy, "Fresh water production from/by atmospheric air for arid regions,using solar energy: Review," *Renewable and Sustainable Energy Reviews*, p. 31, June 2012.
- [85] A. E. Kabeel, "Application of sandy bed solar collector system for water extraction from air," *INTERNATIONAL JOURNAL OF ENERGY RESEARCH*, pp. 381–394, 2006.

**Unsupp
orted
source
type
(Perfor
mance)
for
source
Wea.**

Unsupported source type (Performance) for source Wea.

- [87] Valerie Ndaruzaniye, "Water Security in Ethiopia:Risks and Vulnerabilities' assessment," *Global Water Institute for Africa Climate Change,Environment and Security-Access*, no. 2, p. 15, 2011.
- [88] Ndaruzaniye and Valerie, "Water Security in Ethiopia:Risks and Vulnerabilities' assessment," *Global Water Institute for Africa Climate Change,Environment and Security-Access*, no. 2, p. 15, 2011.
- [89] Ahmed Hamed,Abd elnaby Kabeel and Ayman A. Aly, "A TECHNICAL REVIEW ON THE EXTRACTION OF WATER FROM ATMOSPHERIC

AIR IN ARID ZONES ," 2010.

- [90] "Humidity & Temperature Sensmitter," Switzerland, SHTxx, 2012.
- [91] SHAHID ALI KHAN, "Conservation of Potable Water Using Chilled Water Condensate from Air Conditioning Machines in Hot & Humid Climate," *International Journal of Engineering and Innovative Technology*, vol. 3, no. 2, pp. 182-188, August 2013.
- [92] Z.M.Omara and Abd Elnay Kabeel, "The performance of Different Sand Beds Solar Stills," *International Journal of Green Energy*, pp. 1-15, 2014.
- [93] By Nathan S. Osborne and Cyril H. Meyers, "A FORMULA AND TABLES FOR THE PRESSURE OF SATURATED WATER VAPOR IN THE RANGE," *Rational Bureau of Standards*, no. RP691, p. 21, 1934.
- [94] P. GANDHIDASAN and H.I. ABUALHAMAYEL, "WATER RECOVERY FROM THE ATMOSPHERE," *WREC*, pp. 1-4, 1996.
- [95] "Fresh Water Technology Reviews," India, Raj Nagar, New Delhi,.
- [96] P. GANDHIDASAN and H.I. ABUALHAMAYEL, "WATER RECOVERY FROM THE ATMOSPHERE," Mechanical Engineering Department of King Fahd University of Petroleum and Minerals, Dhahran 3 1261, Saudi Arabia, Scientific WREC 1996, 1996.
- [97] A.M.K. El-Ghonemy, "Fresh waterproductionfrom/byatmosphericairforaridregions,using solarenergy:Review," *ScienceDirect*, vol. 16, no. 6384–6422, p. 6, 2012.
- [98] Ms. Trupti P. Golechha¹, Mr. Arun S. Lonkar², Mr. Sachin Tayde³, Mr. Sk Salikh⁴, "A Technical Review on Atmospheric Water Extraction," no. Special Issue, 2016+.
- [99] Yadav, Manoj Kumar and Avadhesh, "Composite desiccant material “CaCl₂/Vermiculite/Saw wood” :a new material for fresh water production from atmospheric air," *CrossMark Appl Water Sci* , 17 March 2016.
- [100] Manoj Kumar & Avadhesh Yadav, "Comparative study of solar-powered water production from atmospheric air using different desiccant materials," *Renewable Energy*, vol. 9, p. 10, December 2016. [Online]. <https://doi.org/10.1080/19397038.2016.1200692>

[101] Manoj Kumar, Avadhesh Yadav and Neeraj Mehla, "Water generation from atmospheric air by using different composite desiccant materials," 2017.