



**Addis Ababa University**  
**School of Graduate studies**  
**Faculty of Technology**  
**Department of Chemical Engineering**

**CLEANER PRODUCTION ASSESSMENT IN THE ETHIOPIAN ALCOHOL INDUSTRIES**  
**A CASE STUDY IN THE SEBATA ALCOHOL & LIQUOR FACTORY**

**By**

Belay Teffera

**Advisors**

Dr-Ing. Berehanu Assefa

Ato Lelissa Daba

**A Thesis Submitted to the School Of Graduate Studies of Addis Ababa**  
**University in Partial Fulfillment of the Requirement for the Degree of**  
**Master of Environmental Engineering**

*Addis Ababa, Ethiopia*

July 2007

# Acknowledgment

First of all I would like to express my profound gratitude and sincere appreciation to my advisors, Dr-Ing Berhanu Assefa and Mr. Lelissa Daba for their encouragement, unending support and valuable advices before and throughout the study period.

My gratitude is greatly extended to all staffs of the Ethiopian Cleaner production Center for their valuable advices and support with special thanks to Mr. Lelissa Daba, the Director of the Center and Mr. Debebe Yilma, D/Director for Environment Services for their support and constructive comments from the selection of company for the assessment to the end of the project.

My thanks are extended to all workers of Sebeta Alcohol and Liquor Factory, especially for Mrs. Zergi Bulbula, the manger of the factory and process engineers Mr.Gebbru Tafere and Mr. Moges Siyum for their help in my field study in the factory.

My thanks is also extended to the Department of Mechanical Engineering at Technology Faculty of Addis Ababa University (AAU) for providing instrumental support for onsite measuring of those parameters very important in my study.

I would like to thank all the staffs and friends of the Department of Chemical Engineering at Technology Faculty of AAU for their help and cooperation.

I would like to express my heartfelt thanks to Mr. Tewodros Yilma of Yilma Global Consultant and Mr. Haymero Dagneu for their encouragement and support through out the program period.

Finally, I wish to express my extreme gratefulness to my beloved wife Mrs. Meseret Zewudu and my daughter Hillina Belay for their patience, helpfulness, encouragement and moral support during my research period.

# Table of Contents

Acknowledgment.....	1
Table of Contents.....	2
List of Tables.....	5
List of Figures.....	6
Lists of Equations.....	7
Lists of appendices.....	<b>Error! Bookmark not defined.</b>
Acronyms.....	8
<b>Chapter one</b> .....	<b>10</b>
<b>Introduction</b> .....	<b>10</b>
1.1    Cleaner production.....	10
1.1.1    The Development of Cleaner Production.....	10
1.1.2    Cleaner Production and Other Environmental Strategies.....	11
1.1.3    Cleaner Production Assessment Methodology.....	11
1.2    Research Overview.....	12
1.2.1    The Alcohol Industry.....	12
1.3    Statement of the Problem.....	12
1.4    Objective of the Project.....	13
1.4.1    General Objective.....	13
1.4.2    Specific Objectives.....	14
1.5    Significance of the Study.....	14
1.6    Methodology and Approach.....	15
<b>Chapter two</b> .....	<b>16</b>
<b>Literature Review</b> .....	<b>16</b>
2.1    Definitions.....	16
2.2    World Alcohol Production and Ethiopia’s Case.....	17
2.3    Types of Feedstock.....	18
2.4    Ethanol Production Technologies.....	19
2.5    Alcohol Production from Molasses.....	20
2.4.1    Feed Preparation.....	21
2.4.2    Alcohol Fermentation.....	21
2.4.3    Distillation.....	25
2.5    Process Efficiencies and Yields.....	28

2.6	Co-products in Alcohol Fermentation.....	31
2.7	Environmental Impacts .....	33
2.8	Benchmarking and Cleaner Production for Alcohol Industry.....	34
<b>Chapter three.....</b>		<b>37</b>
<b>Materials and Methods .....</b>		<b>37</b>
3.1	On-site monitoring .....	37
3.2	Data Collection.....	37
3.3.1	Molasses .....	38
3.3.2	Water and wastewater measurements.....	38
<b>Chapter four .....</b>		<b>41</b>
<b>Background Information of the Research Site .....</b>		<b>41</b>
4.1	General Information .....	41
4.2	Production .....	41
4.3	Resource consumption .....	42
4.4	Existing Processes Steps .....	43
4.4.1	Feedstock Preparation .....	44
4.4.2	Fermentation Unit .....	44
4.4.3	Distillation unit.....	45
4.3	Liquors Formulation and Filling .....	45
4.3.1	Water Supply.....	45
4.3.2	Energy System.....	46
4.4	Waste Handling Practices.....	46
4.5	Distillery Plant Efficiency .....	46
<b>CHAPTER five .....</b>		<b>47</b>
<b>Cleaner Production Assessment at SALF .....</b>		<b>47</b>
5.1	General .....	47
5.2	<b>Phase I – Sources Identification .....</b>	<b>47</b>
5.2.1	Process Steps and Waste Streams .....	47
5.2.2	Inputs and Outputs .....	49
5.2.3	Material Balance .....	52
5.2.4	Cost of Waste Streams .....	65
5.3	<b>Phase II – Cause Evaluation &amp; Option Generation.....</b>	<b>67</b>
5.3.1	Cause Identification and CP-EE Option Generation.....	67
5.4	<b>Phase III - Evaluation of CP-EE Options .....</b>	<b>70</b>
5.4.1	Screening of CP-EE Options.....	70
<b>CHAPTER Six .....</b>		<b>86</b>
<b>Conclusions and Recommendations .....</b>		<b>86</b>
6.1	Conclusion.....	86

6.2	Recommendation.....	87
6.3	Potential for Further Research and Assistances .....	88
7	<b>Reference</b> .....	89
8	<b>Appendices</b> .....	92

## List of Tables

Table 1- Summaries of Various Grades of Ethyl Alcohol .....	16
Table 2 - Average yields of ethanol from various feedstock .....	19
Table 3 - Composition of Blackstrap and High Test Molasses .....	20
Table 4 - The advantages and disadvantages of batch and continuous fermentations .....	23
Table 5 - Problem, Cause and Solution in Fermentation Process .....	24
Table 6- Expected fermentation yield, Pasture (1850s) .....	29
Table 7 - Values of parameters of a distillery based on sugarcane molasses.....	31
Table 8- Types, Yields and Method of Recovery of Co-products in Alcohol Production.....	32
Table 9– Environmental issues and their magnitude.....	33
Table 10 - Resource Consumption of the Alcohol Production .....	35
Table 11- Composition of Stillage at various countries .....	36
Table 12- Parameters, Methods and Instruments .....	40
Table 13 - Major resource consumption at SALF in 2006 (per liter of 96°GL alcohol).....	42
Table 14 - Distillery plant Efficiency in SALF .....	46
Table 15- Daily Input Consumption in the Distillery Plant .....	49
Table 16 - Water Input per Distillery Process.....	50
Table 17 - Wastewater Flows (m <sup>3</sup> ) and Pollution Loads (mg/l).....	51
Table 18 - Material Balance .....	52
Table 19 -Results of combustion analyzer before Adjustment .....	59
Table 20 - Results of Combustion Analyzer after Adjustment .....	61
Table 21- Parameters of Steam Distribution Pipes and Distillation Columns .....	64
Table 22 - costs of waste streams.....	66
Table 23 - Cause Analysis and Generating CP-EE Options .....	68
Table 24 - Screening the CP-EE Options Generated for implementation, Feasibility Analysis and further studies .....	70
Table 25 - USAB performance on stillage (slop) in India and Venezuela.....	82
Table 26 - Financial Analysis of Anaerobic Digestion Plant.....	83

## List of Figures

Figure 1–Cleaner Production Assessment procedures applied .....	15
Figure 2- Process Steps used to produced alcohol from different feedstock .....	19
Figure 3 -Alcohol Production Volume in SALF through 2004 -2006 .....	41
Figure 4 - Process Flow diagram in SALF .....	43
Figure 5 – Process Flow Diagrams .....	48
Figure 7 -Energy Balance before adjustment for excess air.....	62
Figure 8 -Energy Balance after adjustment for excess air .....	63
Figure 9 -Cause Evaluation: Possible Causes of Waste Generations.....	67
Figure 11 -Existing Condenser Cooling Water System .....	75
Figure 12 -Proposed Condenser Cooling Water System.....	75
Figure 13 - Upflow Anaerobic Sludge Blanket (UASB) .....	81
Figure 14 - Existing Steam Generation and Distribution System .....	84
Figure 15 -Proposed Indirect Heating and Condensate Collection Arrangement.....	85

## Lists of Equations

$$Y_f = \frac{V_b \cdot A_b}{M \cdot S_m} \text{----- Fermentation yield .....28}$$

$$E_f = \frac{Y_f * 0.794}{0.5111 * 1000} * 100 \text{-----Theoretical Fermentation Efficiency .....29}$$

$$E_f = \frac{Y_f * 0.794}{0.484 * 1000} * 100 \text{-----Expected fermentation efficiency .....29}$$

$$E_{de} = \frac{(V_p + V_f)}{V_b} \cdot 100 \text{----- Alcohol recovery .....30}$$

$$A = FS \cdot Y_f \cdot E_{de} \text{----- Alcohol Yield.....30}$$

$$E_o = (E_f * E_{de}) * 100 \text{----- Overall Conversion Efficiency .....30}$$

$$E_o = \left[ \frac{V_p + V_f}{M \cdot S_m} \cdot \frac{0.794}{0.4848} \right] \cdot 100 \text{----- Overall Conversion Efficiency .....31}$$

## Acronyms

BOD	:	Biochemical Oxygen Demand
COD	:	Chemical Oxygen Demand
CP	:	Cleaner Production
CPA	:	Cleaner Production Assessment
ECPC	:	Ethiopian Cleaner Production Center
ESTA	:	Ethiopian Science and Technology Agency
°Br	:	Degree Brix
°GL	:	Degree Gay-Lussac
ht	:	hector-liter or 100 liters
NALE	:	National Alcohol and Liquor Enterprise
TDS	:	Total Dissolved Solids
TSS	:	Total Suspend Solids
SALF	:	Sebeta Alcohol and Liquor Factory
UNEP	:	United Nation Environmental Program
UNIDO	:	United Nation Industrial Development Organization

## Abstract

Sebeta Alcohol and Liquor Factory (SALF) is a sister company of National Alcohol and Liquor Enterprise (NALE). The factory was established in 1914 in Sebeta town and uses molasses as raw material for the production of potable and technical alcohols. It consists of a distillery and filling plants. Its installed daily production capacity is 2500 liters of potable alcohol and about 5000 liters of various liquors. The current production capacity was found to be on average 2100 liters of 95.7°GL potable (fine) and 250 liters of 93°GL technical alcohols per day when the factory was running normally.

Water balance, material balance and energy balance were drawn only for the distillery plant for the filling section was under maintenance during sampling. The molasses, water and energy consumption were found to be 6.3 kg, 168 liters and 22.12 MJ liters per liter of 96°GL alcohol. The average BOD, COD and TDS in the wastewater were 20,866, 53,514 and 19000 mg/l respectively. The total alcohol loss from the fermentation, decantation and distillation process units was significant with the value of 13.22 %. The stillage from mash column is found a severe source of water pollution.

The fermentation efficiency (78.02%), alcohol recovery at distillation unit (83.3%) and overall alcohol conversion efficiency (65.0%) were found to be low compared to values of similar technologies in India, South Africa and Brazil.

The steam generation and distribution systems were studied and the boiler combustion efficiency was found extremely low (29%) resulting from excess air supply. Similarly, other sources of heat loss were identified and carefully examined

The cleaner production options were generated, selected and evaluated for the distillery plant. CO<sub>2</sub> Recovery, Cooling water recycling, lost heat recovery in the stillage and spent lee, indirect heating, generation of methane and fertilizer from stillage were considered for improving resource utilization and reducing pollution loads. Other GHK practices were recommended to bring overall efficiency in the plant.

## Introduction

### 1.1 Cleaner production

#### 1.1.1 The Development of Cleaner Production

The traditional approach to process design is to first design the process and then to design the treatment and disposal of waste streams. However, with increasing regulatory and social pressures to eliminate emissions to the environment and the increase in disposal and treatment costs, requirements have come to analyze the total system altogether (process plus treatment) to find the minimum economic options. Cleaner production techniques provide tools, which address the problems of negative environmental impact and loss of materials to waste. Cleaner production programs can reduce waste generation by 40-50% with internal rate of up to return 200% (Mulholland, 2006).

Cleaner production or pollution prevention was initiated in the USA in the 1970s; when a number of firms undertook hazardous waste and pollution reduction programs resulting in better operating systems and cost reduction. It was adopted by the United Nations Environment Program in 1989 (UNEP, 2001) and was subsequently progressed around the world through the 1990's as a NNEP/UNIDO joint initiatives (US-EAP, 1997).

UNEP defined Cleaner Production as the continuous application of an integrated preventive environmental strategy applied to processes, products and services to increase overall efficiency and reduce risks to humans and the environment.

- ✧ For production processes: Cleaner Production involves the conservation of raw materials and energy, the elimination of toxic raw materials, and the reduction in the quantities and toxicity of wastes and emissions.
- ✧ For product development and design: Cleaner Production involves the reduction of negative impacts throughout the life cycle of the product: from raw material extraction to ultimate disposal.
- ✧ For service industries: Cleaner Production involves the incorporation of environmental considerations into the design and delivery of services.

### **1.1.2 Cleaner Production and Other Environmental Strategies**

CP was developed as a preventive strategy to reduce environmental pollution and simultaneously reduce consumption of material resources. Its main focus is on processes and on reduction of the resources they use. In order to sustain the benefits derived from CP projects, businesses should link or integrate CP objectives with other environmental tools like eco-efficiency, environmental management systems (Hillary, 1997) and production cost reduction strategies such as energy efficiency (UNEP, 2004).

Cleaner production and eco-efficiency are synonymous; the difference is eco-efficiency starts from issues of economic efficiency which have positive environmental benefits while CP starts from issues of environmental efficiency which have positive economic benefits. Strategies such as cleaner production, eco-efficiency and energy efficiency provides the technical solutions whereas the management systems lay down the structural frameworks for the continuity and sustainability of proposed programs/operations by these strategies. This paper tries to develop cleaner production and energy efficiency (CP-EE) options and recommends use of management tools to reduce wastes and improve resource utilization.

### **1.1.3 Cleaner Production Assessment Methodology**

Methodologies for undertaking a cleaner production assessment have been developed in the late 1980's through the 1990's and will no doubt continue to be developed and further refined through decades during application to an ever increasing range of industries (Thomas,2004).

Cleaner production Assessment essentially involves *source identification, cause evaluation and option generation* (Van Berkel, 1995), though varied nomenclature has been applied. The practitioners establish a benchmark by identifying pollution sources, seek to determine why these exist and develop the “how to” to overcome pollution issues. Planning and implementation may also be viewed as part of the larger process.

## **1.2 Research Overview**

### **1.2.1 The Alcohol Industry**

Alcohol production can be traced far back in human history, but it has still found uses in new industrial processes (GEA, 2006). Ethanol alcohol is a versatile substance that is widely used in the chemistry, medicine, food, and pharmaceutical industries (GEA, 2006; Yu 19991). Today, one of the most important of these is the fuel market; it will have a successful future as a sustainable source of energy (GEA, 2006).

The raw materials for alcohol production through fermentation are those containing sugars. These materials are classified under three types of agricultural raw materials: sugar, starches and cellulose feedstock. One of the most widely used feedstock for alcohol (ethanol) fermentation is molasses which is the by-product of the sugar refineries. Molasses is the main feedstock to distilleries in Ethiopia.

The utilization of molasses as raw material for the alcohol industry requires attention for its possible environmental impacts. The molasses based alcohol industries are grouped under chemical industries which produce numerous organic pollutants, and cause serious contamination (Bhatia, 2001). The biochemical oxygen demand (BOD<sub>5</sub>) and chemical oxygen demand (COD) typically range between 35,000-50,000 and 100,000-150,000 mg/liter respectively (Yeoh et al, 2004).

## **1.3 Statement of the Problem**

Distilleries are among the industries having high polluting effect to the environment due to large organic load associated with their discharges. Currently, most distilleries in Ethiopia are

discharging their effluents to adjacent rivers directly without treatment. As consequence, they have faced strong complaints from the local communities and environmental offices. Sebeta Alcohol and Liquor Factory (SALF) is among these distilleries. Moreover, the food and beverage industry is among heavy polluters and could be targeted for environmental enforcement measures by Environmental Protection Authority (EPA) of Ethiopia. Currently, SALF has already warned by the environmental protection bureau of Oromia regional State with regard to its discharges.

The factory, therefore, requested the Ethiopian Cleaner Production Center (ECPC) to come up with a design for an end-of-pipe treatment unit. ECPC opted for carrying out a CP Assessment so as to quantify and characterize the wastes being discharged and recommend on a further improvement activities. Accurate information about the origins and sources of environmental releases is a prerequisite to design and implement effective environmental measures for the reduction of industrial wastes and emission. However, information from distilleries revealed that most of them lack the resources and expertise to carry out these activities by themselves.

Therefore, the researcher was assigned to conduct the CP Assessment at Sebeta Alcohol and Liquor Factory (SALF) in the framework of the University-Industry Cooperation in consultation with the Chemical Engineering Department of the Addis Ababa University to identify origins and sources of wastes, evaluate causes, generate and propose CP options for reducing, reusing and recycling wastes and thus reducing costs of final treatment. It is expected that the study will contribute in improving resource utilization and reducing pollution loads to the environment through the application of CP techniques within similar companies and for the sustainable development of the sector at large.

## **1.4 Objective of the Project**

### **1.4.1 General Objective**

The objective of this study is to identify and evaluate cleaner production options in the Sebeta Alcohol and Liquor Factory aiming to improve resource utilization efficiency, and reduce environmental loads and subsequent negative impacts.

### **1.4.2 Specific Objectives**

- To identify sources, quantities and characteristics of wastes.
- To determine material and energy balances and assign costs to waste streams.
- To identify causes of wastes and generate cleaner production Options.
- To evaluate the selected CP options for technical, environmental and economical viability.

### **1.5 Significance of the Study**

Recent advances in solving the problem of disposal of liquid effluent generated by distilleries have led to the application of anaerobic treatment process (Bhatia, 2001). Due to the highly organic load, it is indicated that it is no possible to bring down the BOD/COD levels to acceptable emission standards by anaerobic treatment alone, it requires aerobic treatment and activated sludge systems (Bhatia, 2001). The implementation of effluent treatment schemes has been the large capital investment involved in setting up the treatment plants. The capital cost, in more cases, of the treatment plant is as much as the cost of the distillery itself and in the case of the old distilleries; this cost is almost prohibitive.

The sustainability of the alcohol fermentation industry will depend very much on the cleaner production approach that will mitigate the polluting effects through efficient use of resources and waste minimization options such as re-use and recycling. Pollution load can be reduced through plant efficiency, improved water and energy conservation, recycled waste products, and process modification ( Fuentes et al, 1983)

An essential step in implementing cleaner production is CP assessment as it gives a comprehensive look at production process to facilitate the understanding of material flows and to show pollution sources within the process. A CP assessment identifies specific areas where pollution reduction may be achieved and helps to implement maximum resource optimization and improved process performance (UNEP and UNIDO, 1991).

This study examines current practices in resources utilization and environmental handling of distilleries, SALF as focal point, which uses molasses as feedstock and recommended viable cleaner production options for the alcohol production through fermentation in Ethiopia.

## 1.6 Methodology and Approach

The methodology applied in this thesis work involved: gathering and reviewing literature, obtaining and analyzing company input/output data, onsite monitoring, and laboratory analysis and organizing final paper. The procedure illustrated in figure 1 below was adopted from CP Assessment Manuals developed by UNEP in 1996 and Cleaner Production –Energy Efficiency Manual in 2004 and used as guide to identify sources and causes of wastes, generate and evaluate CP-EE options.

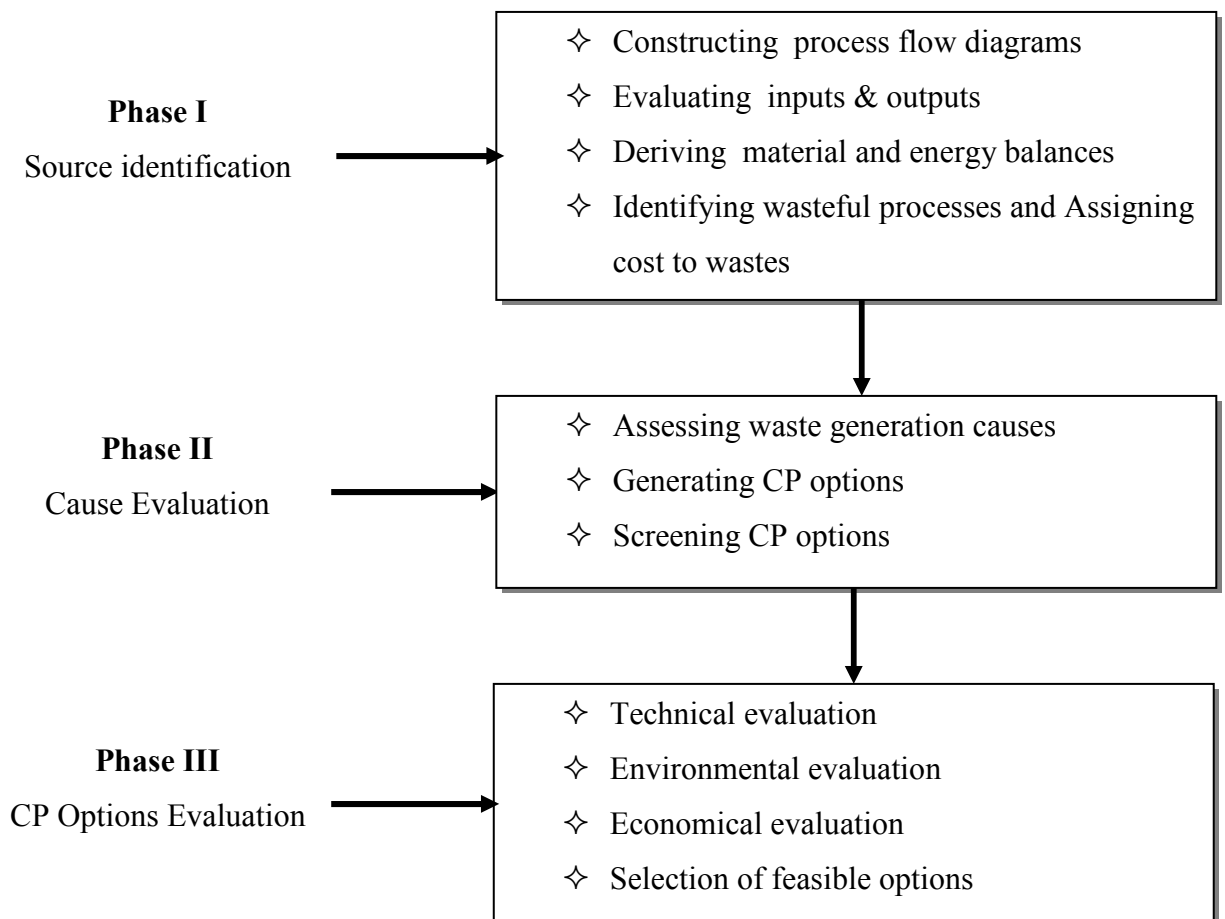

Figure 1–Cleaner Production Assessment procedures applied

## Literature Review

### 2.1 Definitions

**Alcohol** - In industrial nomenclature alcohol means ethyl alcohol ( $C_2H_5OH$ ), this is also known as “ethanol”, “grain alcohol”. It has a specific density 0.7937 and a boiling point  $78.32^{\circ}C$  at 1 atmospheric pressure (Paturau, 1969). Ethyl alcohol is a versatile product which can be used for various purposes, mainly as solvent, beverages, and raw material for making hundreds of chemicals, such as aldehydes, ethyl acetate, acetic acid, glycols, ethyl chloride, and many other organic compounds. The units of measurement commonly used in reporting ethyl alcohol production are the proof gallon or Gay Lussac degree ( $^{\circ}GL$ ) which is equal to the per cent by volume of ethanol. Proof is twice of the Gay Lussac degree ( $^{\circ}GL$ ) (Prescott et al, 1949).

**Table 1-** Summaries of Various Grades of Ethyl Alcohol

Category	Grade ( $^{\circ}GL$ )	Typical Use
Industrial alcohol	96.5	As solvent, fuel, and also as raw material for production of numerous chemical products.
Denatured spirit	88	Generally used as heating and lighting
Fine alcohol (either hydrous and anhydrous)	96-96.5	A purer form of alcohol where substantially all impurities are removed. It is used mainly for pharmaceutical and cosmetic preparation and for human consumption.
Absolute or anhydrous alcohol	99.7-99.8	It is a water-free ethyl alcohol used as engine fuel and pure product of pharmaceutical grade.

**Beer:** fermented mash. In some literature it is also called wine.

**Degree Brix:** Unit of solid content in molasses

**Feint alcohols:** mixtures of low volatile alcohols which are difficult to separate.

**Fusel oil:** higher alcohols (90-150°C) formed decomposition by yeast of amino acids and collected in the rectification column..

**Inoculum or leaven:** the amount of yeast that is added to the mash to be fermented.

**Mash:** a fresh and diluted molasses ready either for fermentation or as medium for yeast propagation. It is also known as must.

**Stillage:** the wastewater discharged off from the mash column. It is also known by the names slop, vinnase or dunder.

## **2.2 World Alcohol Production and Ethiopia's Case**

Ethyl alcohol has been used by man since the dawn of history (Precote, 1949; Parturau, 1969). Ethanol must have been originally produced by the spontaneous fermentation of sugars, but as time went modern man learned to control this fermentation to produce alcoholic beverages. With the advancement of synthetic organic chemistry in the second half of the 19<sup>th</sup> century, alcohol became indispensable as a fuel, as solvent, as an antiseptics and as an intermediate for the production of a number of organic compounds.

The trend towards cleaner, reformulated gasoline has been largely responsible for the growing ethanol industry in the world. World demand for ethanol has increased substantially in recent years for use in ethanol/gasoline blends. The world annual ethanol production in 2000 was about 17.6 billion liters, but this figure has grown to 40.8 billion liters by 2006.

The production of alcohol (ethanol) in Ethiopia in factories traces back to the beginning of the 20th century, even though the number of firms involved in this sub-sector is still very limited. Today, there are only five distilleries, namely 'Fincha', 'Mechanisa', 'Akaki', 'Sebeta' and 'Balezaf'. Finicha which is under Fincha Sugar Factory produces 8 million liters of technical alcohol per annum for domestic and export market; the other four are autonomous plants producing both potable and technical alcohols with annual total production of about 2.8 million liters.

All sugar factories in the country are under preparation to include distillery plants and produce mainly fuel alcohol. When these distilleries start producing, it is expected that by the year 2009 annual total alcohol production will be over 95 million liters and this figure will grow to 128 million liters by the year 2012.

### 2.3 Types of Feedstock

Ethyl alcohol may be produced from any fermentable sugar by yeast under suitable conditions (Prescott et al, 1949). The feedstock are classified into three principal types: (a) the saccharine materials such as sugarcane, sugar beets molasses and fruit juices; (b) the starchy materials, which include the cereals (corn, barely, wheat, sorghum and the like), and potatoes; and (c) cellulose materials, such as wood and other wastes.

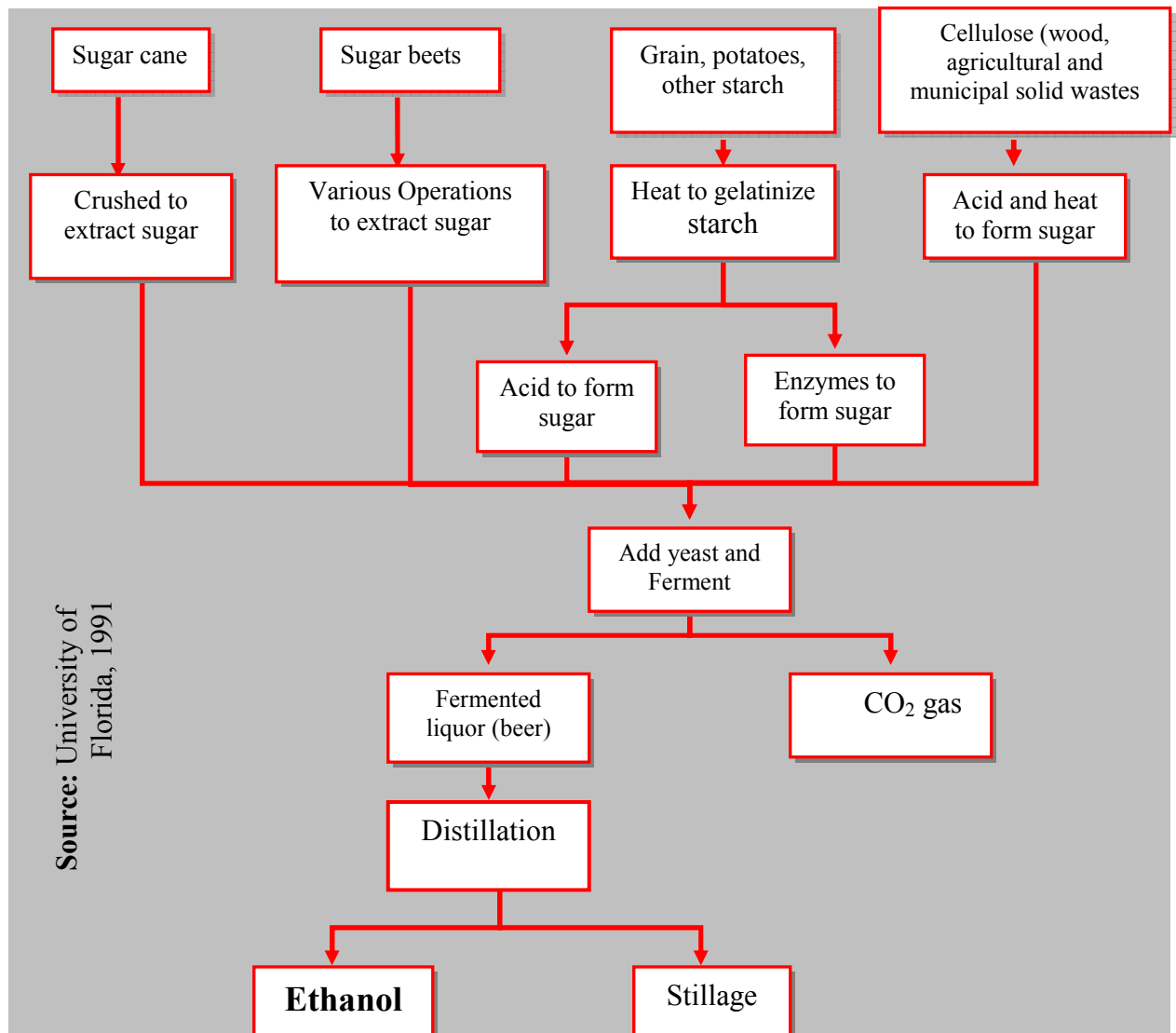

Figure 2- Process Steps used to produced alcohol from different feedstock

**Table 2** - Average yields of ethanol from various feedstock

Material	Alcohol /tone of feedstock	
	(Prescott et al, 1949)	(Shapouri 2006)
Wheat	322	-
Corn	317	371
Grain sorghum	301	-
Barely	300	
Blackstrap molasses	266.5	262.68
Sorghum cane	266.5	-
Sweet potatoes	130	-
potatoes	87	-
Pineapples	59	-
Raw sugar	-	512.49

## 2.4 Ethanol Production Technologies

The nature of the feedstock puts certain constraints on the technology required for the manufacture of ethanol. For example, molasses or sugar solutions can be fermented directly by yeast, using traditional and well-established technology. However, cellulose feedstock such as wood or bagasse must be hydrolyzed into component molecules and sugars before fermentation by one or more specifically selected microorganisms.

Ethanol alcohol production technology can generally be divided into two main categories: Technologies that convert **starch or sugar-based feedstock** into ethanol; and technologies that convert **cellulose feedstock** into ethanol (Washington DC, 2001). The majority of ethanol produced today falls into the first category, and utilizes corn, potatoes and other grains as feedstock to produce ethanol using either a dry or wet process or sugar-based feedstock such as sugar juice or molasses. Since at present, all Ethiopian distilleries uses only cane molasses, this study paper did not considered technologies using other feedstock.

## 2.5 Alcohol Production from Molasses

The molasses can be either blackstrap or invert molasses. Blackstrap molasses is a by-product from sugar mills where as invert or high-test molasses is produced by heating sugarcane juice at acid reaction, neutralizing it, and evaporating it (Paturau, 1969). Blackstrap and invert molasses contain about 50% and 95% of fermentable sugar respectively (Alico, 1982). However, exact composition of molasses is difficult to predict. It is influenced by soil and climatic conditions, variety and maturity of cane and the processing conditions in the factory (Alico, 1982). In Table 1 average composition of components of blackstrap and high test molasses are indicated.

**Table 3 - Composition of Blackstrap and High Test Molasses**

Element	%	
	Blackstrap molasses	High Test molasses
Water	15 - 25	14
Total Solids (Brix) <sup>a</sup>	83 - 85	86
pH	Above 5	6
Specific gravity	1.39 - 1.49	1.43
Sucrose	30 - 40	-
Glucose	4 - 9	77
Fructose	5 - 12	-
Total reducing sugars	45 - 50	
Other reducing substances	1 - 5	-
Total fermentable sugar <sup>a</sup>	40 - 46	95
Ash	7 - 15	2.5
Nitrogenous compounds	2 - 6	0.15
Organic Non-sugars <sup>a</sup>	20 - 25	-

Source: Paturau (1969) and <sup>a</sup>Alico (1982)

There are three basic stages that need to occur in the production of ethanol from sugar products: formation of a solution of fermentable sugars; fermentation of sugars to ethanol; and the separation of ethanol by distillation.

### **2.4.1 Feed Preparation**

Feedstock preparation will vary with the feedstock. Molasses differs from other feedstock such as corn, sorghum, and potatoes etc. which have their carbohydrate content stored as starch which is usually precooked and hydrolyzed into fermentable sugars. The carbohydrates in molasses are readily in the form of sugars and need no pretreatment. Sucrose is the principal sugar contained in molasses and is readily fermentable either directly, or as its glucose and fructose components.

Since molasses form a viscous fluid containing about 84% dissolved solids (sugars and non-sugars), a preliminary dilution is required in order to render the medium suitable for yeast. As a rule, this is about 18 – 20 degree Brix (Santos, 1990). The water used for dilution should be potable to avoid contamination by bacteria and wild yeast. Since the optimum pH for yeast activities lies in the range of 4 - 5, the acidity of the diluted syrup is adjusted for optimum yeast activities at pH 4.5 – by adding 2 – 2.5 g H<sub>2</sub>SO<sub>4</sub> per lire of dilute syrup (Santos, 1990).

The medium, especially used to prepare the yeast inoculum, is corrected for phosphorus and nitrogen as the nutrients of the yeast for optimum results. Nitrogen should not be in the form of ammonium sulfate and liquid ammonia as they cause scaling (as calcium sulfate) and raising the pH that encourage bacterial contamination respectively (unpublished article). An excellent vehicle for these two nutrients is diammonium hydrogen phosphate; which is added the order of 100 g per m<sup>3</sup> of dilute syrup (Santos, 1990).

### **2.4.2 Alcohol Fermentation**

#### **2.4.2.1 General**

Fermentation can be defined as an enzymatically anaerobic controlled transformation of organic substrates such as sugars. Although fermentation is only one step in the production process, it is the key step in the production of alcohol. Alcoholic fermentation is one of the oldest, established and most important of industrial fermentations.

In the fermentation process sugars are transformed into ethanol by addition of yeast. Fermentation time varies from 4 - 12 hours, chemical efficiencies range from 80-90%, resulting

in an alcohol content of 7-10° GL, called fermented mash or beer. The beer may be filtered or centrifuged in order to recover and recycle the yeast.

The principal reactions in alcohol fermentations are;

**Reactions for monosaccharide production:** if sugar (sucrose) is fermented it must be inverted by enzyme invertase to yield glucose which can then be converted to alcohol as shown below.

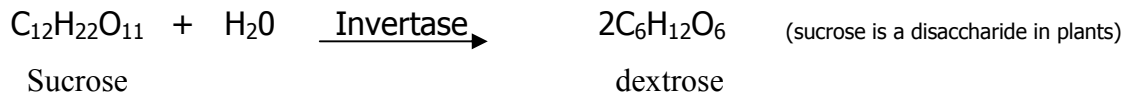

(monosaccharide) sugars, the yeast enzymes convert the sugars into alcohol as described below.

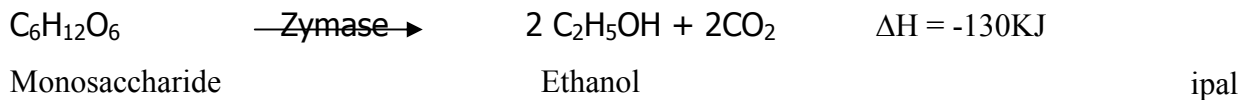

equations in an acid or low pH medium. This fermentation, like so many industrial reactions, is much more involved than these simple reactions indicate. All sugars will not change to alcohol, some amount of acetic acid and glycerin are always found in alcohol fermentations. Towards the ends of a fermentation, acidity and the glycerin increase.

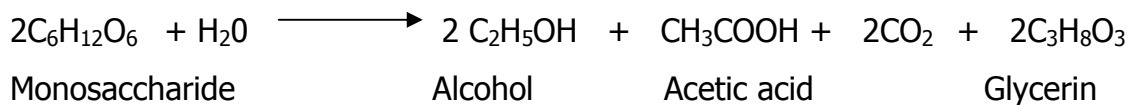

### 2.4.2.1 Types of Process

Fermentation can be carried out either through intermittent or continuous processes. The intermittent can further be divided as individual inocula (batch) and cutting processes (Santos, 1990). In the individual inocula (batch) process each fermentation vessel receives yeast inoculum in a volume corresponding to 20-25% of the useful volume of the vessel. The yeast inoculum is obtained from either a pure culture unit or a pre-fermenter (mother fermenter where yeast propagation is taking place). Upon completion of the fermentation process, the entire content of

the fermenter is sent to distillation, discarding the yeast biomass with the slop of the distillation. This process is expensive, given the high requirements for nutrients and acids.

In the “*cutting process*”, the mash is fed into the first of series of fermentation tanks, each of which overflows into the next tank, and the fermented beer is drawn from the last tank (Paturau, 1969, Santos). In continuous fermentation process additional mash is added continuously or at short time intervals to the fermenter (Paturau, 1969; Alico, 1982; Santos 1990).

**Table 4 - The advantages and disadvantages of batch and continuous fermentations**

Bach fermentation	Continuance fermentation
<p><b>Advantages</b></p> <ul style="list-style-type: none"> <li>• Control of microbial contamination;</li> <li>• Control of ethanol quality per batch.</li> </ul> <p><b>Disadvantages</b></p> <ul style="list-style-type: none"> <li>• High capital requirement for large-scale;</li> <li>• Decrease in volumetric efficiency fermenters;</li> <li>• Possible variations from batch to batch, requiring homogenizing.</li> </ul>	<p><b>Advantages</b></p> <ul style="list-style-type: none"> <li>• High volumetric efficiency;</li> <li>• Yeast recycling;</li> <li>• Establishment of a flow growth-rate equilibrium;</li> <li>• A more consistent product;</li> <li>• Lower capital and lower costs;</li> <li>• Reduced time requirements.</li> </ul> <p><b>Disadvantages</b></p> <ul style="list-style-type: none"> <li>• High potential for serious microbial contamination;</li> <li>• Homogenizing is still required, despite a consistent product.</li> </ul>

**Source:** (Alico 1982)

#### **2.4.2.2 Process Options in Fermentation**

According to Paturau (1969), the fermentation processes that are generally used in molasses distilleries include:

- (i) **Usines de Melle Process:** In this process option the beer from the fermentation tank is passed through centrifugal separators before being sent to the stills, and the yeast cells are separated, mixed with fresh mash, and used as footing in the fermentation tanks.

- (ii) **Two-Stage process:** This process uses stillage in which to grow the yeast needed for seeding. The unfermented sugars present in molasses are hydrolyzed in the stills so that the stillage contains enough sugar to support the yeast growth aerobically.
- (iii) **Arroyo process** - which involves clarification and pasteurization of the mash before fermentation. By reducing the sugar-to-ash ratio and increasing the amount of fermentable sugars, the process makes it possible to obtain beers of high alcoholic content (10 -13%) and increased fermentation rates(duration about 30 hours)

### 2.4.2.3 Factors Affecting Fermentation

Yeasts are the most commonly used microorganisms responsible for producing the enzymes that convert glucose to ethanol. Saccharomyces is the yeast genus generally used in ethanol production. Many factors affect yeast activity during alcoholic fermentation. The most important of these include:

**Table 5 - Problem, Cause and Solution in Fermentation Process**

<b>Problem</b>	<b>Cause</b>	<b>Solution</b>
Inactive and death of yeasts	High osmotic pressure and alcohol toxicity	Diluting molasses to 20-22°Brix to adjust sugar concentration in the molasses so that the alcohol content in the beer is below 12%.
Bacterial or wild yeast Contamination	pH higher than 5	Acidifying the mash to pH lower than 5.
	Old molasses or produced under unsanitary situations	Using clean equipment and disinfectants like SO <sub>2</sub> in the range of 20-50 ppm to the fresh mash.
Loss of yield and quality deterioration by bacteria.	Over heating due to the heat evolved from the fermentation process.	Cooling units to prevent temperature from exceeding 30-32°C
Scaling in the pre-heaters and mash column.	Presence of calcium compounds in the molasses.	<ul style="list-style-type: none"> <li>• Using hydrochloric acid instead of sulfuric acid to adjust the pH in the yeast propagation to avoid formation of calcium sulfate.</li> </ul>

		<ul style="list-style-type: none"> <li>• Using hot water for dilution of molasses so that to increase the settling of suspended solids.</li> <li>• Decanting the beer to remove solids.</li> </ul>
--	--	--

### **2.4.3 Distillation**

#### **2.4.3.1 General**

Distillation is defined as a process in which a liquid or vapor mixture of two or more substances is separated into its component fractions of desired purity, by the application and removal of heat (Tham, 1997). The use of distillation on fermented solutions to produce distilled beverages with a higher alcohol content is perhaps the oldest form of distillation, known since ancient times (Encyclopida of Wikipedia).

Distillation is based on the fact that the vapor of a boiling mixture will be richer in the components that have lower boiling points. Therefore, when this vapor is cooled and condensed, the condensate will contain more volatile components. At the same time, the original mixture will contain more of the less volatile material. Conventional distillation generally takes place at atmospheric pressure (constant pressure).

#### **2.4.3.2 Process Options**

There are many types of distillation columns, each designed to perform specific types of separations and each design differs in terms of complexity. There are two general types of distillation processes commonly used in the alcohol production; the batch and continuous-feed distillation column systems.

In a batch operating mode, the column is started, brought to a balanced performance and operated until the quantity of beer on hand is distilled. The column must then be shut down, cooled and cleaned, ready for start-up for the next batch. In such cases, the start-up and shut-down operations result in high losses in energy and efficiency. A batch distillation process is

simple and applicable for minimum – labor alcohol production, but requires about three times as much energy as an equivalent continuous distillation system (Kvaalen, 2006).

In the continuous-feed distillation column system, beer containing alcohol content is continuously pumped into a column and no interruptions occur unless there is a problem with the column or surrounding process units.

#### **2.4.3.3 Distillation of Potable Alcohol**

The nature of the feedstock and the metabolic activity of the fermenting micro-organism give rise to a great number of organic components other than ethanol (O.Leppanen et al, unpublished article). Therefore, the potable ethanol distillation system cannot be designed on the basis of the separation of ethanol and water alone. It is also important to take into account the behavior and separation of a large number of impurities in the raw alcohol.

The production of rectified spirit from fermented mash generally incorporates at least three distillation columns, namely mash, predistillation and rectification columns. When high grade potable alcohol is needed, methanol removal column is included to the distillation system. The number of columns and their interconnections are determined by the quality of the raw material, the required purity of the product and the desired energy consumption of distillation.

#### **Mash column**

In the mash column, alcohol is fractionated from fermented mash so that alcohol vapor with a concentration of 35 -50 % (wt) is taken at the top and essentially alcohol-free stillage is taken at the bottom. A mash column generally has 18 to 20 trays. The mash fed to the column is usually preheated by the vapor taken at the top. A mash column operating at low pressure produces a cleaner raw spirit (O.Leppanen et al, unpublished Article), which can be subsequently purified more easily and results in higher yield because of the need to take a smaller predistillate fraction.

Furthermore, a lower distillation temperature reduces both the burning of residual sugars and proteins onto surfaces of the column and the precipitation of calcium sulfate, thus prolonging the cleaning time of column and save energy.

### **Predistillation Column**

The raw distillate from the mash column runs to the predistillation column for purification. The predistillation column is designed to separate substantially all the impurities (aldehydes, esters, etc.) from the ethanol/water mixture. Here, the net result is that the ethanol/water mixture is removed from the bottom of the predistillation column while the impurities are taken overhead. In practice, to obtain an effective separation of impurities water must be added to the predistillate column to dilute the relatively high ethanol concentration of the raw alcohol feed.

### **Rectification column**

The main purpose of the rectification column is to concentrate the diluted alcohol stream from the bottom of the predistillation column. A rectification column normally has 65 – 72 trays. At the top of the column a fraction is taken containing enriched light impurities. The concentrated alcohol product is drawn off at the top of the lower section, fusel alcohols are taken from middle and spent lee (wastewater) from the bottom.

### **Methanol Column**

A methanol column is used to obtain an extremely pure alcoholic distillate by removing methanol and residual impurities (mainly aldehydes) from the product obtained from the rectification column. It generally has 50 - 70 trays and consumes 1.5 – 2.5 MJ/kg of ethanol in the feed.

### **2.4.3.4 Energy Saving Options**

Because quality is a major factor in the production of potable alcohol, any reduction in distillation energy cannot be allowed to result in deterioration of the product quality. The production of alcohol for technical purpose or for fuel, however, is less affected by distillation at elevated temperatures (O.Leppanen et al, unpublished Article). Most developments in alcohol distillation have aimed at saving in steam consumption while improving the quality of the alcohol. Beyond column design, this may be achieved through efficient process control and heat recovery.

One point to prevent heat loss is to use well insulated distillation columns. A loss of heat along the column causes increased condensation and reduced evaporation, which requires more vapor from the reboiler or steam generator, resulting in a loss in energy efficiency. Two to three inches of fiberglass blanket insulation will protect heat loss from distillation columns (Kvaalen, 2006). Heat recovery from stillage in the column bottoms during distillation and heat absorbed in the condenser can be a source of energy efficiency.

Thermal efficiency has been increased by using heat exchanger to preheat the cold beer either by means of the hot stillage or the alcohol vapors or combination of both (Paturau, 1969). The total steam consumption would vary with different feed temperatures and different alcohol concentration in the beer. Thus the best way to operate to save energy is to have a good fermentation (high alcohol content in beer) and to preheat the feed and to better control the start-up and the shut-down processes.

## 2.5 Process Efficiencies and Yields

There are a number of ways to determine operational efficiency and yield in a distillery. According to the South Africa Sugar Manufacturers Association, the four commonly used measures of yield are fermentation yield, fermentation efficiency, alcohol recovery and overall conversion efficiency

### Fermentation yield

Fermentation yield is measured in liters of absolute alcohol in the fermented mash or beer per tonne of sugars in molasses, and is calculated by the formula below

$$Y_f = \frac{V_b \cdot A_b}{M \cdot S_m} \text{----- Equation 1 - Fermentation yield}$$

Where:  $Y_f$  = fermentation yield,  $V_b$  = volume of beer [liter]

$A_b$  = alcohol content of beer (v/v)

$M$  = mass of molasses [in tonne] and  $S_m$  = fermentable sugars content of molasses (m/m)

**Fermentation efficiency**

Fermentation efficiency is an expression of how much alcohol was actually produced in beer relative to the amount that could be theoretically produced, and is given by;

$$E_f = \frac{Y_f * 0.794}{0.5111 * 1000} * 100 \quad \text{-----Equation 2- Fermentation Efficiency}$$

The factor 0.794 corresponds to the specific gravity of absolute alcohol and the factor 0.5111 is best explained as follows: according to Gay-Lussac equation, if one kilogram of sugar was completely fermented (using theoretical 100% efficient yeast); 511.1 grams of alcohol and 1000 - 511.1 = 488.9 grams of carbon dioxide would result (Prescott et al, 1949; Paturau, 1969)

However, Pasteur (1857) demonstrated through a series of experiments that the optimum yield to be expected would be as follows, expressed as a percentage of sugar fermented

**Table 6- Expected fermentation yield, Pasture (1850s)**

<b>Substance</b>	<b>% by weight</b>
Ethyl alcohol	48.4
carbon dioxide	46.6
glycerol	3.3
succinic acid	0.6
cellulose, etc	1.2

The above value of 48.4% ethyl alcohol obtained by Pasteur represents about 94.85% of the theoretical 51.11% of Gay-Lunacy. Therefore, the actual fermentation efficiency is greater than the fermentation efficiency based on theoretical alcohol yield and can be calculated from the formula below;

$$E_f = \frac{Y_f * 0.794}{0.484 * 1000} * 100 \quad \text{-----Equation 3 - Expected fermentation efficiency}$$

## Alcohol Recovery

Alcohol recovery is a measure of how much alcohol was finally produced relative to the amount that was in the beer. It shows the amount of losses in the evaporation and distillation sections. Alcohol recovery is calculated as follows;

$$E_{de} = \frac{(V_p + V_f)}{aV_b} \cdot 100 \quad \text{-----Equation 4 - Alcohol recovery}$$

Where;  $E_{de}$  = Alcohol recovery (or distillation and evaporation efficiency)

$V_p$  = volume of potable alcohol as liters of absolute alcohol

$V_f$  = volume of feints as liters of absolute alcohol

$aV_b$  = volume of beer in liters of absolute alcohol

Distillation efficiency varies in practice between 92 and 98% and an average of 97.5% is usually attended (Paturau, 1969)

## Alcohol Yield

The amount of alcohol produced is given by

$$A = FS \cdot Y_f \cdot E_{de} \quad \text{-----Equation 5 – alcohol Yield}$$

Where; A = liters of alcohol produced

$FS$  = fermentable sugar content (kg)

$Y_f$  = fermentation yield and  $E_{de}$  = Alcohol recovery (or distillation efficiency)

## Overall Conversion Efficiency

Overall conversion efficiency is a measure of how much alcohol is finally produced relative to the amount that could be theoretically produced, and is given by;

$$E_o = (E_f * E_{de}) * 100 \quad \text{-----Equation 6 - Overall Conversion Efficiency}$$

Where;  $E_o$  is overall efficiency of a distillery.

Using equations through 1 to 6, the overall conversion efficiency of the distillery can be rewritten as follows;

$$E_o = \left[ \frac{(V_p + V_f)A_b}{M \cdot S_m} \cdot \frac{0.794}{0.4848} \right] \cdot 100 \quad \text{-----Equation 7 Overall Conversion Efficiency}$$

Where;

$V_p$  = volume of potable alcohol as liters absolute alcohol

$V_f$  = volume of feints as liters absolute alcohol

$M$  = mass of molasses [in tonne] and  $S_m$  = fermentable sugars content of molasses (m/m)

Table 7 below shows efficiencies that one would expect in a well run sugarcane molasses based distillery.

**Table 7** - Values of parameters of a distillery based on sugarcane molasses

parameters	Values		
	S. Africa <sup>†</sup>	India <sup>*</sup>	USA
Alcohol yield (lt of alcohol\tone of molasses)	248.34	240	263
Fermentation Yield (lt of alcohol\tone of molasses)	573	545	565
Fermentation Efficiency (%)	89	88.72	-
Distillation efficiency (%)	98.5	98.24	-
Overall Conversion Efficiency	87%	87.16	-

**Sources:**

<sup>†</sup> South African Sugar Producers Association

- Global Agriculture Information Network (2006), Bio-Fuels Production Report, India

## 2.6 Co-products in Alcohol Fermentation

During the process of fermentation and distillation in alcohol production, a number of by-products are collected; some of sufficient values to influence the financial results of the alcohol plant are carbon dioxide, fusel oil, stillage and yeast (Paturau, 1969, Alico 1982).

**Table 8- Types, Yields, Use and Method of Recovery of Co-products in Alcohol Production**

Co-product	operation	Property, Potential yield and Use	Methods of recovery
<b>Carbon dioxide</b>	<b>Fermentation</b>	<ul style="list-style-type: none"> <li>☞ 180kg/1000kg of molasses used, of this, 70-75 % can be recovered</li> <li>☞ used mainly in brewage industries, (Paturau, 1969, Alico, 1982)</li> </ul>	<ul style="list-style-type: none"> <li>☞ Adsorption or absorption</li> <li>☞ It is washed, deodorized and dried before it is compressed to 70kg/cm<sup>2</sup> and then sold either in liquid form or flashed cooled to about -40°C into solid ice. (Paturau, 1969)</li> </ul>
<b>Yeast</b>	<b>Fermentation</b>	<ul style="list-style-type: none"> <li>☞ 0.703kg/lt of ethanol produced (Alico, 1982)</li> <li>☞ Returned and used in the first fermenter especially in “cutting” fermentation technique (Prescott et al, 1949).</li> </ul>	<ul style="list-style-type: none"> <li>☞ By centrifugal separators</li> <li>☞ only few commercial operation recover yeast (Alico, 1982)</li> </ul>
<b>Fusel oil</b>	<b>Distillation</b>	<ul style="list-style-type: none"> <li>☞ they are mixture of higher alcohols consist mainly of amyl and iso-amyl alcohol with b.p 90-150°C (Paturau, 1969)</li> <li>☞ 1.1 Liters fusel oil per 1000 liters of ethanol from molasses fermentation, but larger quantities from potatoes and corn (Prescott et al, 1949).</li> <li>☞ used as chemical feedstock, solvent and fuel (Alico, 1982)</li> </ul>	<ul style="list-style-type: none"> <li>☞ usually not refined or separated into its components (Paturau, 1969)</li> <li>☞ They are collected in the rectified column and separated by extraction column</li> <li>☞ For small scale plant, it is not economical to extract fusel oil compared to energy used (Alico, 1982)</li> </ul>
<b>Stillage</b>	<b>Distillation</b>	<ul style="list-style-type: none"> <li>☞ Acidic, brown and hot (90°C) liquid waste.</li> <li>☞ Up to 35 % of the stillage can be used for mash preparation, yeast propagation (B.G. Yeoh et al 2006) and it can also be used as fertilizer and animal feed.</li> </ul>	<ul style="list-style-type: none"> <li>☞ It is used as animal feed or fertilizer either directly or concentrated by vacuum evaporation.</li> </ul>

## 2.7 Environmental Impacts

As for many food industries, the environmental problems of the alcohol industry are mainly connected with water use, water pollution and energy consumption.

**Table 9– Environmental issues and their magnitude**

<b>Environmental and safety issues</b>	<b>Magnitude</b>
<b>Water consumption</b>	<ul style="list-style-type: none"> <li>☞ The alcohol industry uses considerable quantities of drinking-quality water for feedstock preparation, cleaning, cooling, steam production as well as floor washing purposes.</li> <li>☞ The amount depends on factors such as the raw materials, final product, technologies and operating practices.</li> <li>☞ On average, 250 liters of water is used per liter of potable alcohol produced.</li> </ul>
<b>Energy Consumption</b>	<ul style="list-style-type: none"> <li>✧ Large amount of thermal energy for distillation and rectification, and in some cases for the clarification and sterilization of the molasses.</li> <li>✧ The energy requirement vary according to the types of feed stock used, content of the alcohol in the fermented beer, type and quality of product required and the technology used at generation through distribution and usage (Paturau, 1969).</li> <li>✧ On average, 14-18 MJ of energy/ liter of 100% potable alcohol produced (O.Leppanen et al, unpublished Article)</li> </ul>
<b>Wastewater</b>	<ul style="list-style-type: none"> <li>○ The stillage is by far the most important liquid effluent in terms of polluting potential from alcohol distilleries.</li> <li>○ Its acidic nature, its high BOD content, its enormous volume 12-14 liters /liter of ethanol produced (Moreira, 2006; Bhatia, 2001), makes its treatment the most difficult factor in the total environmental impact of alcohol distilleries.</li> <li>○ When no restriction is applied, the non-ethanol component of the final fermented beer will end up as stillage.</li> </ul>

<b>Solid wastes</b>	<ul style="list-style-type: none"> <li>• They are produced from the treatment of wastewater from the process of yeast propagation, fermentation, and decantation and distillation stillage.</li> <li>• Every liter of alcohol produced gives 1.3-1.4 kg of total solids (Bhatia 2001).</li> <li>• Other types of solid wastes may include broken bottles, bottle containers etc.</li> </ul>
<b>Emissions to Air</b>	<p>↗ Air emissions in alcohol production are primarily related to carbon dioxide in the fermentation unit, flue gas combustion for steam generation and the evaporation of ethanol from spent wash and leakages during processing activities and storage facilities.</p>
<b>Safety</b>	<p>Alcohol distillation involves some dangers such as the explosion or burning of alcohol and blow-out of components due to pressure build-up. Some of the precautions include:</p> <ul style="list-style-type: none"> <li>☞ To avoid smoking anywhere in or around the building or equipment</li> <li>☞ To remove any presence of air by so that the air will be replaced with steam before the alcohol is introduced.</li> <li>☞ To install adequate pressure gauges and control limits in the condenser to sense product pressure, near the base of the mash and rectifying columns to sense internal column pressure and in the steam injector nozzle to sense steam pressure being applied.</li> </ul>

## 2.8 Benchmarking and Cleaner Production for Alcohol Industry

Benchmarking refers to the comparison of different features of an individual company with the best (or worst) companies of its kind. Companies may use benchmarking as a tool to measure their performance both externally and internally. Benchmarking can help a company to

determine where CP options exist so that it can target its efforts selectively by comparing certain aspects of its operations with alcohol production plant using similar raw materials and technologies. While internal benchmarking can help a company set for its specific CP targets- the company measures its progress relative to its past performance.

CP indicators are quantitative or qualitative measures used in the benchmarking of a company. Quantitative indicators relate some input to a processing step like consumption of raw material, water, energy or generation of wastes (such as BOD, COD, TSS) to the desired alcohol produced. On the other hand, qualitative indicators consider the existence of an operation or an environmental practice and an instruction (for example, the existence of an emergency plan) in a given alcohol production plant.

### Resource consumption

Molasses, water and energy are resources that are consumed in considerable quantity in alcohol production. Table 9 gives the average resource requirement of alcohol production from molasses.

**Table 10 - Resource Consumption of the Alcohol Production**

Operation	Unit	Consumption per liter alcohol produced			
		(Paturau, 1969)		(Moreira,2006)	(O.Leppanen et al)
		Ind. alcohol	Fine alcohol	Fuel alcohol	Fine alcohol
<b>A. fermentation</b>					
Molasses	kg	3.8	3.8	-	-
Water	m <sup>3</sup>	0.15	0.15	0.1994	-
Steam (kg/cm <sup>2</sup> pressure)	kg	0.3	0.3	-	-
Electric energy	kWh	0.028	0.028	-	-
Sulphuric acid	kg	0.03	0.03	-	-
Nutrients like NH <sub>4</sub> SO <sub>4</sub>	kg	Variable	Variable	-	-
<b>B. Distillation</b>					
Water	m <sup>3</sup>	0.08	0.10	0.2632	-
Steam (kg/cm <sup>2</sup> pressure)	kg	3.0	5.5	-	5 – 7
Electric energy	kWh	0.005	0.001	-	-

## Wastewater

Wastewater from ethanol production, known as stillage is by far the most important liquid effluent in terms of its polluting potential from ethanol distilleries. Its acidic, high BOD content and large volume makes its management the most important factor in the environmental impact of the ethanol distillery. It covers 70% of the polluting potential of an ethanol industry (Moreira, 2006).

**Table 11- Composition of Stillage at various countries**

Components	India	Brazil	Ethiopia	Ethiopia
	(Stewart, 2004)	(Moreira, 2006).	EPA, 2005	Draft Standard,2005
Feedstock	Molasses	Molasses	Molasses	
Volume (lt)	9-12 <sup>†</sup>	9-17	-	-
BOD (mg/l)	27000-52000	6680-75330	21,000	<b>60</b>
COD (mg/l)	80,000-120,000	9200-97000	-	<b>250</b>
TS (mg/l)	50,000-140,000	10780-38680	-	-
TSS (mg/l)	2000-14,000	260-9500	-	-
TDS (mg/l)	-	1509-33680	-	-
pH	3.3 - 4.5	3.5-4.9	-	<b>6-9</b>
Temperature (°C)	-	90-100	-	<b>40</b>

## Materials and Methods

### 3.1 On-site monitoring

Regular on-site survey and monitoring were carried out to understand the process operations, utility sections, type of raw material used and products being produced. The existing production processes, water supply and wastewater systems, steam generation and distribution systems were carefully followed. Process flow diagrams were sketched and inputs and outputs of each production process were identified.

### 3.2 Data Collection

Relevant company data on raw materials (molasses, sulphuric acid, DAP, fuel) and their unit costs, electric consumptions and their bills and other available information were collected as much as possible.

#### 3.1 Material and Energy Balance

Material balance was carried out for each unit process based on existing data, measured and estimated quantities for input raw materials, water supply, wastewater and product after each unit operation.

Energy balance was carried out only for steam component. Measurement of steam amount was also not possible. It was calculated from material balance.

### **3.3.1 Molasses**

The volumetric quantity of molasses used for each batch process was estimated by measuring the Brix of molasses before and after the dilution process. Then, the average density of molasses was determined by weighing known volumes of molasses to calculate the average mass of molasses used.

### **3.3.2 Water and wastewater measurements**

Records of water supply and wastewater discharges were not available in the factory. Moreover, there are no installed water flow meters to monitor and control water consumptions at all activities.

#### **3.3.2.1 Water Supplied Measurement**

The total water supplied volume estimated through pump capacity is not accurate for the pump is not operating at a constant capacity. It was tried to measure water using digital flow meters borrowed from Mechanical Engineering Department of AAU, but it fails to give reliable measurement. Therefore, quantities of water for processes, washing and cleaning at each unit operation were measured using a known volume container and watch.

#### **3.3.2.2 Wastewater Measurement**

Wastewaters from different processes of the plant are discharged into the adjacent river either through pipe lines or open channels. The rectangular concrete channels collect wastewater from feedstock preparation, yeast propagation, fermentation and decantation operations. The spent washes, condenser cooling water and steam condensates from boiler operations and are drained to the river through pipes. It was very difficult to measure wastewater flow rate in the factory because of the poor drainage system especially the stillage and the condenser cooling water.

Since wastewaters originate and join the river at different points, using weir to measure wastewater flow rate was impossible. The wastewater volume for each batch operation was measured separately by container method, using a known volume container and time counter.

### **3.3.2.3 Water and Wastewater Characterization**

Parameters: pH, alkalinity and hardness for raw water; BOD, COD, TSS and TDS for wastewater streams were measured using laboratory facilities at the factory, at the main branch of the National Alcohol and Liquor Enterprises and Department of Civil Engineering at the Faculty Technology of AAU.

## **3.4 Energy Balance**

For energy balance, the important measurements are feed water, steam and air flow rates and flue gas compositions besides temperature and pressure measurements. However, due to lack of instruments, only the flue gas composition and the surface temperatures were measured directly using flue gas analyzer (Kane KM9104) and a digital thermocouple respectively. Steam condensate flow rate (from a steam trap) was measured onsite, whereas heat losses in blow down, discharges through safety valve and pressure gauges were estimated for they were difficult to measure. The total steam flow rate was also determined from total material balance computation.

**Table 12- Parameters, Methods and Instruments**

<b>Parameter</b>	<b>Method</b>	<b>Instrument s</b>	<b>Place of analysis</b>
<b>Molasses</b>			
Brix	Direct measuring	Brix Meter	At factory and main branch
Sugar content	Benedict Test	Titration set up	At factory and Main branch
<b>Alcohol</b>			
Alcohol content	Direct measuring	Alcoholometry	At factory and main branch
<b>Raw water</b>			
pH	Direct measuring	HANA meter	At factory laboratory
TDS	Direct measuring	HANA meter	>>
Alkalinity	Titration using EDTA	Titration set up and measuring cylinders and pipettes	>>
Hardness	Titration using EDTA	Titration set up and measuring cylinders and pipettes	>>
<b>Wastewaters</b>			
TDS	Direct measuring	Wagtech M 4330	Civil Engineering Dep. Lab, AAU
TSS	Filtration and gravimetry	-----	>>
BOD	Inolab Oxi level 2	Incubation chamber 20°C	>>
COD	Dichromate open reflux	-----	>>

**Background Information of the Research Site**

**4.1 General Information**

The Sebeta Alcohol & Liquor Factory (SALF) is one of the oldest alcohol companies in the country starting operation in 1914. It is a state-owned company under National Alcohol & Liquor Enterprise (NALE) and located in Sebeta town, 25 km south of Addis Ababa. The factory has an installed capacity of producing and filling 2500 and 5000 liters of potable alcohol and various types of alcoholic liquors per day respectively. At present, its distillery plant produces on average 2100 and 250 liters of potable (fine) and technical alcohols a day respectively. SALF has 125 permanent and 20 (on average) temporary works and operates around 300 days per year, on three shifts a day during high market demand (plant layout is depicted in appendix 1)

**4.2 Production**

The distillery plant produces technical and potable alcohols. The total production is normalized in terms of the total potable alcohol produced on the basis of the resources used during the production of alcohol. Figure 4 shows the production volume of the last three years(2004/06).

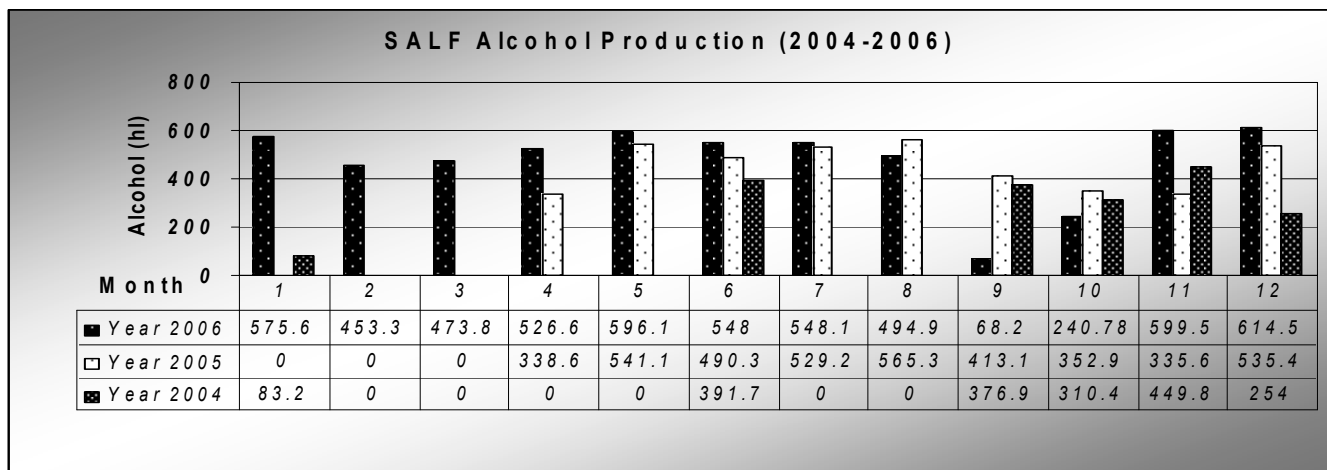

**Figure 3 -Alcohol Production Volume in SALF through 2004 -2006**

### 4.3 Resource consumption

The factory uses molasses as the main raw material for producing alcohols. In the year 2006, the factory produced **573,938 liters** of both technical and fine alcohols. The consumption of major resources per liter of alcohol produced for the year 2006 is shown in table 13.

**Table 13** - Major resource consumption at SALF in 2006 (per liter of 96°GL alcohol)

Resources	Unit/lit alcohol	Month												Ave.
		Jan	Feb	Mar	Apr	May	Jun	Jul	Aug	Sep	Oct	Nov	Dec	
<b>A. Raw materials</b>														
Molasses	kg	6.03	6.72	6.74	5.5	6.39	6.13	6.13	5.9	-	7.4	5.12	6.54	<b>6.24</b>
H <sub>2</sub> SO <sub>4</sub>	10 <sup>-2</sup> kg	2.55	2.22	3.01	2.36	2.0	2.19	2.32	1.9	2.3	2.3	1.9	3.03	<b>2.34</b>
DAP	10 <sup>-3</sup> kg	1.92	2.1	1.9	1.53	2.95	3.39	1.65	1.7	2.2	3.1	1.9	1.4	<b>2.15</b>
Yeast	10 <sup>-3</sup> kg	-	-	-	-	-	-	-	-	-	-	-	8.17	<b>0.74</b>
Salt	10 <sup>-3</sup> kg	1.75	1.11	2.12	0.95	2.53	3.66	2.75	2.0	-	4.2	1.7	3.3	<b>2.37</b>
<b>B. Water</b>														
Municipal	m <sup>3</sup>	-	-	-	-	-	-	-	86	69	40	-	-	-
Borehole	m <sup>3</sup>	-	-	-	-	-	-	-	-	-	-	-	-	-
Recycle or	m <sup>3</sup>	-	-	-	-	-	-	-	-	-	-	-	-	-
Total	m <sup>3</sup>	-	-	-	-	-	-	-	-	-	-	-	-	-
<b>C. Energy</b>														
Fuel oil	liters	0.51	0.64	0.54	0.56	0.51	0.65	0.55	0.61	0.67	0.8	0.46	0.39	<b>0.574</b>
Energy	MJ	21.9	27.1	23.2	24.1	21.05	28.0	23.7	26.2	28.8	34.4	19.8	16.4	<b>24.56</b>
Equivalent electricity from fuel oil	kwh	6.08	7.53	6.44	6.69	5.97	7.78	6.58	7.28	8.0	9.56	5.5	4.56	<b>6.83</b>
Grid(10 <sup>-3</sup> )	kwh	2.72	2.83	2.58	4.33	3.75	3.92	3.95	2.29	2.57	9.6	3.5	3.77	<b>3.82</b>
<b>Total Energy</b>	kwh	6.08	7.53	6.44	6.69	5.97	7.78	6.58	7.28	8.0	9.56	5.5	4.56	<b>24.56</b>

**Note:** Energy values include that consumed by bottling section. But generally, the energy demand of this section is less than 10% of the total energy consumed.

#### 4.4 Existing Processes Steps

Alcohol manufacture in the SALF distillery plant involves three main operations viz. feed preparation, fermentation, and distillation. Figure 4 shows the process flow diagram.

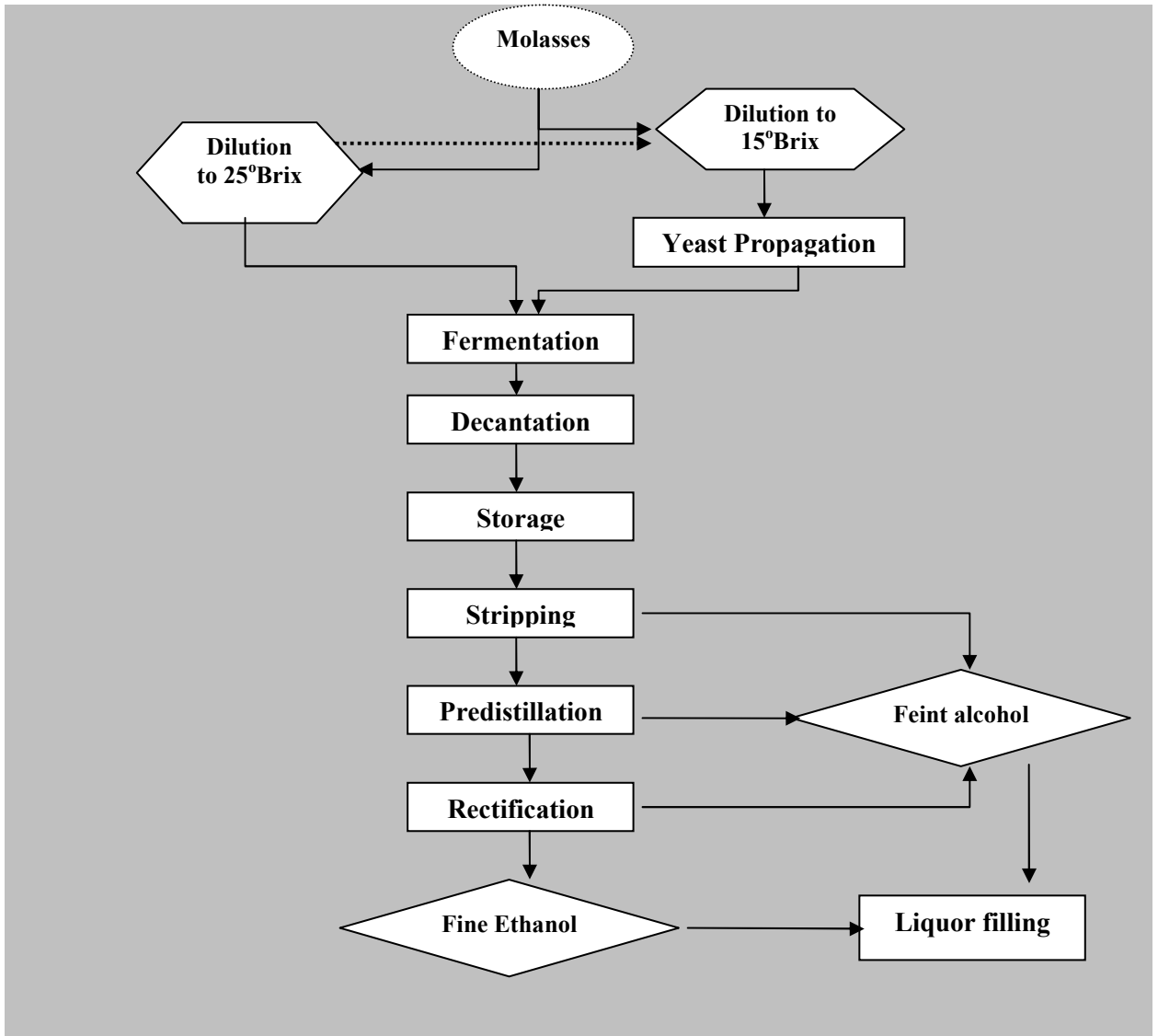

**Figure 4** - Process Flow diagram in SALF

#### **4.4.1 Feedstock Preparation**

At this stage, the raw molasses from stock with solid content that ranges between 75 – 83 (average 78.4 ) degree Brix is diluted with water to obtain 25 degree Brix, (actual on average 27.5 °Br), called High Brix molasses mash. On adjacent tank, another mixture of 15 degree Brix, (actual on average 15.6 °Br) called Low Brix mash is prepared by diluting with water either using raw molasses from the stock or by taking the freshly prepared High Brix mash. The pH of the Low Brix mash is adjusted to 3.5 - 5 by the addition of sulphuric acid and used to propagate yeast.

#### **4.4.2 Fermentation Unit**

In this unit, there are three processes: yeast propagation, fermentation and fermented mash (i.e. beer) clarification.

On average every six month, a new yeast culture is prepared in the plant from dried baker-yeast. First, about 20 g of dried yeast is nourished in the laboratory and then put into two concrete tanks with capacity of 120 liters. The solution is transferred into another two equal rectangular concrete yeast seed tanks (7000 liters each), where the Low Brix mash is used as medium. Here, Diammonium phosphate (DAP) is added to compensate nutrient deficiencies in the molasses to serve as a food for the yeast.

Once the yeast inoculum is fully developed, about 5000 liters of High Brix is transferred into the fermentation vessel immediately followed by 3500 liters of inoculum from one of the yeast mother fermenter. On average, after 5-6 hours another 3500 liters of inoculum is added from the other yeast mother fermenter and 8000 liters of High Brix fresh mash is added to make the total mash equal to 20,000 liters which is the capacity of the rectangular concrete fermentation tanks. As the biochemical reaction precedes, the content of the mash (Brix), pH, temperature of the mixture are measured and registered. The mixture stays on average 48 hours in the fermenter.

Once fermentation is completed, i.e. when the carbon dioxide evolution has stopped and foams have disappeared, the content of the fermenter is transferred into a decantation tank. This tank is cylindrical in shape with inverted cone in the bottom to accumulate and discharge the sludge

intermittently. The clarified beer just above the cone of the decantation tank is pumped into a temporary beer storage tanks (two in number).

#### **4.4.3 Distillation unit**

The beer from temporary storage tank is pumped up, on average 1350 l/h, to pass through a preheater (heat- exchanger) that is connected to the overhead vapor line from mash column. The pre-heated beer (on average 60° C) is fed into the middle of the mash column where a direct steam from boiler is provided at the bottom of the column and heated at constant pressure of 1.5 bar. The vapor after preheating the cold beer passes through two other condensers. Then parts of it (they call it denature alcohol) is separated from the raw distillate using small decanter and large proportion of it refluxed into the mash column and then drawn off from the top of the same column to the predistillation column where almost all impurities (high volatile components) are removed.

In the predistillation column, the raw distillate is heated with steam to automatically controlled temperature of 78°C. After the mixture of the high volatile alcohols is collected immediately after the condenser connected to the overheads of the predistillation column and low volatile mixture is refluxed back into the top of the column and then transferred to last distillation column, called rectification column where the alcohol is separated from water. The column is adjusted to operate at about 78°C and 100 mbar temperature and pressure respectively. After every hour, the percentage of the alcohol is checked by laboratory technicians using alcoholmeter.

### **4.3 Liquors Formulation and Filling**

This section of the factory consists of the bottle washing, liquor formulation and filling units. This section was under maintenance during onsite monitoring for data collection and, therefore is not included in the study.

#### **4.3.1 Water Supply**

Groundwater is the source of raw water supply for the factory. It is only at rainy seasons it uses municipal water for reasons that during these times the water from boreholes deteriorates in

quality (discussion with production manager). However, the company document did not clearly reveal this option of water source.

### 4.3.2 Energy System

The factory uses electrical energy for driving electrical equipment such as pumps, compressors, mixers, office machines and lighting; steam energy is used for the distillation and bottle washing operations.

### 4.4 Waste Handling Practices

Except for some inadequate solid waste segregation of broken bottles and metal scraps, there is no a waste reuse or treatment practice in the facility.

### 4.5 Distillery Plant Efficiency

Based on the baseline data collected for three years (2005-2006) on resource utilization and production output, the overall conversion efficiency of the distillery plant is given table 14. This data was also considered as a baseline for further comparison and source of waste identification.

**Table 14 - Distillery plant Efficiency in SALF**

Parameter	Unit	Production year		Remark
		2005	2006	
Molasses	kg	2,476,000	3,488,140	
Fermentable sugar	%	39.0	39.0	Low, may be due to burning of sugar at sugar mills
Fermentable sugar	kg	965,640	1,360,375	
Fermentation efficiency <sup>†</sup>	%	-	-	Equation 3 and 4 can not be solved for $V_b$ is not known.
Total alcohol produced	liters	410,150	573,938	
Distillation efficiency <sup>‡</sup>	%	-	-	
Overall conversion efficiency of the plant <sup>a</sup>	%	<b>56.4</b>	<b>56.06</b>	Low, compared to other countries.

<sup>†</sup> based on equation 3; <sup>‡</sup> based on equation 4, and <sup>a</sup> based on equation 7 of this thesis work.

## CHAPTER

# FIVE

## Cleaner Production Assessment at SALF

### 5.1 General

As CP - EE focuses on processes that cause the waste stream, the central element of the CP-EE methods should be to examine and evaluate the production process and energy generation and distribution system. This evaluation consists of a “source identification” followed by a “cause evaluation” and “option generation” (Berkel, 2005).

Accordingly, for the source identification, an inventory was made to identify the material and energy flows entering and leaving each process step and the process flow diagram of SALF is prepared. Next, the cause that influences the volume and composition of the waste and emissions are generated. The next logical step (Option generation) was to create means how to eliminate or control each of the causes of wastes and emissions. Once the CP options have been identified, the options were evaluated for technical, environmental and economical viability.

### 5.2 Phase I – Sources Identification

#### 5.2.1 Process Steps and Waste Streams

A process flow diagram is an essential step to check for waste generations and thereby compile the list of major waste sources. A process flow diagram showing the major process steps and waste streams of SALF is depicted as shown in figure 5.

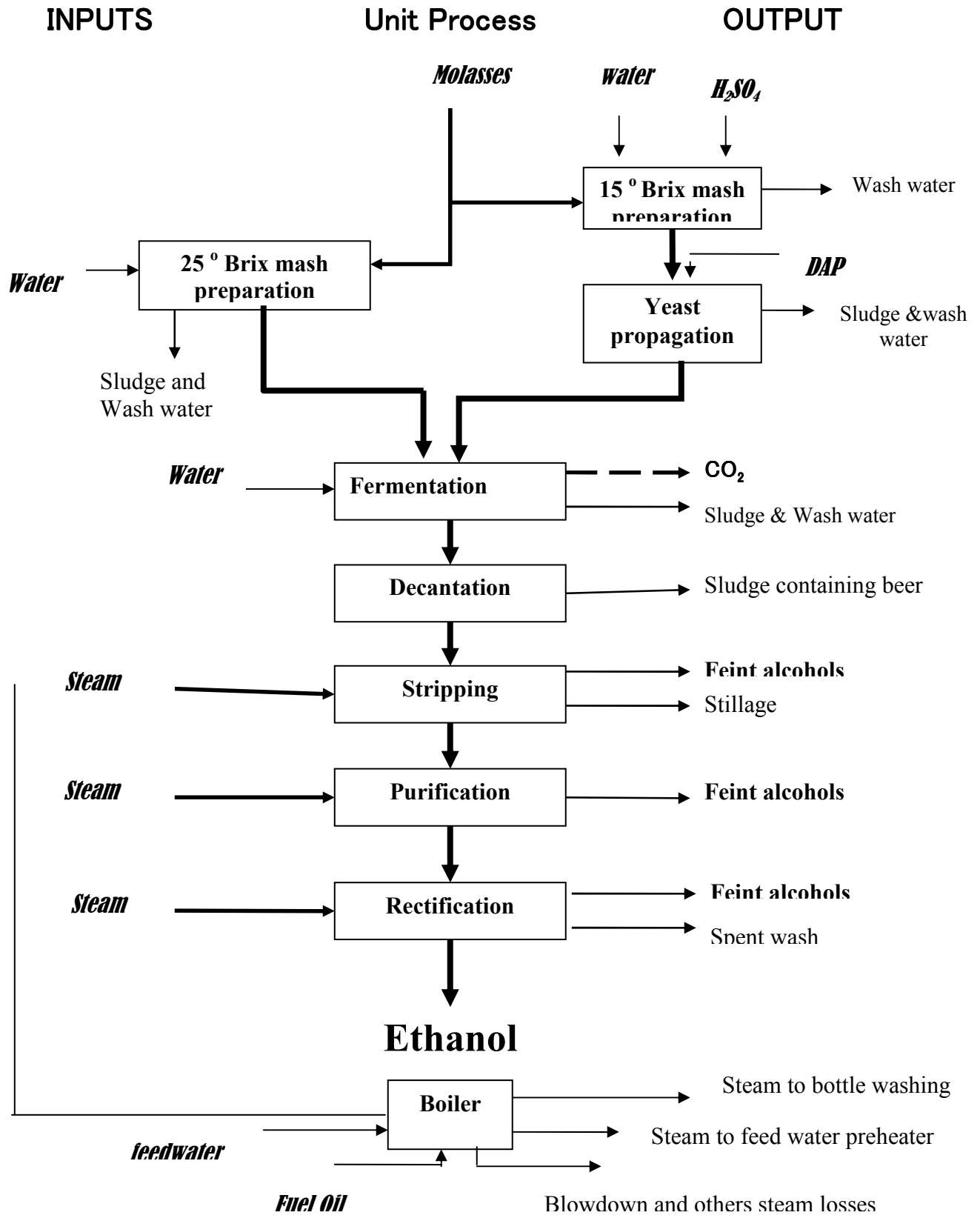

Figure 5 – Process Flow Diagrams

## 5.2.2 Inputs and Outputs

### 5.2.2.1 Raw materials, Chemicals and Fuel consumption

At current operation, the average daily consumption of inputs other than water is summarized in table 15 below.

**Table 15- Daily Input Consumption in the Distillery Plant**

Input	Unit	Unit cost (Birr)	Average daily consumption		Consumption per liter 96 GL fine alcohol produced	
			Quantity	Cost in Birr	Quantity	Cost
Molasses	kg	0.0622	15,285	950.73	<b>6.33</b>	0.394
H <sub>2</sub> SO <sub>4</sub>	kg	3.8	48	182.4	<b>0.0197</b>	0.075
DAP	kg	2.63	3.04	7.99	<b>0.0013</b>	0.0034
Fuel	liters	3.52	1158.86	4079.2	<b>0.494</b>	1.74
Water	m <sup>3</sup>	0.22 <sup>+</sup>	<b>395<sup>*</sup></b>	86.9	<b>0.168</b>	0.037
Average input material cost per liter of 96°GL alcohol produced						<b>2.25</b>

\* Including an assumed 3% water consumption for general services (drinking, toilet services etc.) and <sup>+</sup> Pumping cost per m<sup>3</sup> of water.

### 5.2.2.2 Water and Wastewater

Monitoring of operation units individually and as whole was carried out for several days starting from feedstock preparation to distillation in order to quantify water consumption and wastewater discharges. On average, two batches are processed every day, for the production of 2122 liters of potable and 240 liters of feint (they call it denature) alcohols respectively. The daily water consumption and wastewater discharges are given in Table 16 and 17.

Table 16 - Water Input per Distillery Process

<b>Process</b>	<b>m<sup>3</sup> water/hl of alcohol</b>	<b>m<sup>3</sup> water/day</b>
<b>High Brix Preparation</b>		
Process water	0.719	16.897
Washing	0.053	1.250
<b>Low Brix preparation</b>		
Process water	0.477	11.210
Washing water	0.0085	0.200
<b>Yeast propagation</b>		
Washing water	0.007	0.165
<b>Fermentation</b>		
Washing water	0.027	0.640
<b>Distillation</b>		
Condenser Cooling water	18.38	345.00
<b>Floor washing</b>	0.076	1.786
<b>Total</b>		<b>377.147</b>
Total process water = 28.109 m <sup>3</sup> water/day (7.45 %)		
Total vessel washing water = 2.255m <sup>3</sup> water/day (0.6%)		
Floor washing water =1.786m <sup>3</sup> water/day (0.47%)		
Condenser cooling water = 345 m <sup>3</sup> water/day (91.48%)		

The water consumption for the distillery plant consists of process and washing water (377.2m<sup>3</sup>/day), boiler feed water (13.2 m<sup>3</sup>/day) and water for general purposes (gardening, drinking, toilet services etc). If the latter constitutes 1% of the other two, the total water consumption can be estimated to 395 m<sup>3</sup>/day

**Table 17 - Wastewater Flows (M<sup>3</sup>) and Pollution Loads (mg/l)**

<b>process</b>	<b>Flow (m<sup>3</sup>/d)</b>	<b>BOD (mg/l)</b>	<b>COD (mg/l)</b>	<b>TSS (mg/l)</b>	<b>TDS</b>
<b>High Brix Preparation</b>					
Wastewater from dilution	0.12	3870	6970	281	14,800
Wastewater from vessel washing	1.250	2080	5760	260	11,780
<b>Low Brix Preparation</b>					
Wastewater from dilution	-	-	-	-	-
Wastewater from vessel washing	0.20	1890	3820	320	12,840
<b>Yeast Propagation</b>					
Wastewater from vessel washing	0.165	ND	ND	1200	23,432
<b>Fermentation</b>					
Wastewater from fermentation	1.2	3,330	8,900	1502	18,500
Wastewater from vessel Washing	0.640	1140	2834	7162	12,720
<b>Decantation</b>					
Wastewater from decantation	1.0	15,300	48,030	1846	12,650
<b>Distillation</b>					
Condenser Cooling Water	345.00	-	-	-	0.13
Wastewater (stillage) from mash column	28.56	23,910	61,110	255	19,950
Wastewater(Spent Lees) From Rectification	9.48	-	-	-	0.1
Total wastewater and weighted average values of waste	<b>474.62</b>	<b>20866.9</b>	<b>53514.0</b>	<b>477.0</b>	<b>19025.4</b>

### 5.2.2.3 Air emission

It is evident that a significant quantity of carbon dioxide is emitted from the fermentation process of the distillery plant. Operators express their discomfort due to the gas. Based on the daily molasses consumption and fermentation process, about 2770kg of CO<sub>2</sub> is calculated to be produced from the fermentation unit.

### 5.2.3 Material Balance

Table 18 - Material Balance

Process	Input material		Output material (kg)		Waste streams	
	Name	Quantity (kg)	Name	Quantity (kg)	Liquid (Kg)	Solid /gas (kg)
H.B mash preparation	Molasses	11,707	27.5°Brix mash	27,874	1713	--
	Process water	16,880				
	Washing water	1000				
L.B mash preparation	Molasses	3573	15.6°Brix mash	14,781	240	--
	H <sub>2</sub> SO <sub>4</sub>	48				
	Process water	11,200				
	Washing water	200				
Yeast preparation	15.6°Brix mash	14,781	Yeast inoculum <sup>†</sup>	13,417	--	CO <sub>2</sub> <sup>†</sup>
	DAP	3.04				
fermentation	27.5°Brix mash	27,874	Fermented mash (beer)	37,043	1962	CO <sub>2</sub> <sup>†</sup>
	Yeast inoculum	13,417				
	Washing waster	640				
Decantation	Beer	37,043	Clarified alcohol	35,840	1200	--
Stripping	Clarified beer	35,840	Stillage	--	33,170	--
			Feint alcohols	85.6	--	--
	Steam	S <sub>1</sub>	Distillate	2604.4 +S <sub>1</sub>	--	--
Predistillation	Distillate	2604.4 +S <sub>1</sub>	Feint alcohols	128.4	--	--
	Steam	S <sub>2</sub>	Distillate	2476+S <sub>1</sub> +	--	--
Rectification	Distillate	2476+S <sub>1</sub> +	Feint alcohols	85.6	--	--
	Steam	S <sub>3</sub>	Potable alcohols	1760	--	--
			Spent lee	10830		
<b>Balance</b>		<b>S<sub>1</sub>+ S<sub>2</sub>+ S<sub>3</sub></b>	<b>10,114 kg of steam used</b>			

<sup>†</sup> Theoretical yield of carbon dioxide from biochemical reaction of sugar

<sup>+</sup> Assuming weight generation and accumulation during yeast growth is small

From table 18 above, it can be seen that for every liter of alcohol (96°GL) it is required about 4.31 kg of steam on average at 10.4 bar absolute pressure. This value is in good agreement with the literature values.

So as to estimate the amount of steam entering to each distillation column, namely the mash, predistillation and rectification column and recheck the above result in a different way, total and component mass balance computation were carried out, of course assuming that all the alcohol is ethanol. The computation was done as follows:

**a) Mash column**

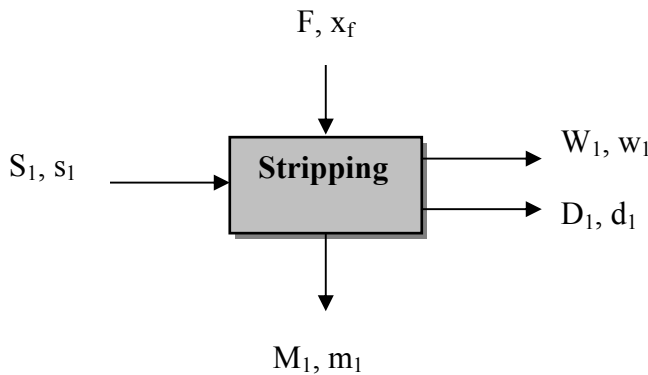

**Where;**

F = beer in kg/hr and alcohol content,  $x_f = 8.1\%v/v = 6.45\% w/w$ ,

$S_1$  = steam enter into mash column and  $s_1 = 0$ , (i.e. alcohol in steam)

$M_1$  = distillate to the predistillation Column and alcohol content  $m_1 = 53\% v/v = 47.24\% w/w$

$D_1$  = feint alcohols in kg/hr and alcohol content  $d_1 = 93\% (v/v) = 91.34\% (w/w)$ ,

$W_1$  = stillage in kg/hr and alcohol content  $w_1 = 0.5\% v/v = 0.37\% w/w$

**Total mass balance**

$$S_1 + F = W + D_1 + M_1 \quad \text{-----(1)}$$

**Component Balance for alcohol**

$$S_1s_1 + Fx_f = Ww_1 + D_1d_1 + M_1m_1 \quad \text{----- (2)}$$

Since there are two unknowns in equation 1, first equation 2 was used to solve for  $M_1$ . Converting all quantities into mass flow rates and %v/v into %w/w, we get:

$$S_1 \cdot 0 + 1375 \text{ kg/hr} \cdot 0.0645 = 1270.92 \text{ kg/hr} \cdot 0.0037 + 3.28 \text{ kg/hr} \cdot 0.9134 + M_1 \cdot 0.4724 \dots (3)$$

$$M_1 = 184.13 \text{ kg/hr}$$

Thus from equation 1, the amount of steam that enters to the mash column is calculated as;

$$S_1 + 1375 \text{ kg/hr} = 1270.92 \text{ kg/hr} + 3.28 \text{ kg/hr} + 184.13 \text{ kg/hr} \dots (4)$$

$$S_1 = 83.33 \text{ kg/hr} \quad (\text{Ans.}) \dots (5)$$

**b) Predistillation column:** similar procedure was employed to calculate the amount of steam entering into the predistillation column.

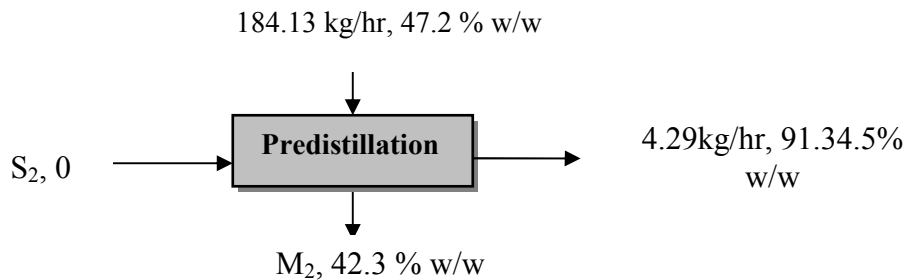

Total Mass Balance

$$S_2 + M_1 = F_2 + M_2 \dots (6)$$

Component Balance for Alcohol

$$S_2 s_2 + M_1 m_1 = F_2 f_2 + M_2 m_2 \dots (7)$$

Substituting values for the variables in equation 7, the average value of the distillate that flows into the rectification column is calculated as follows;

$$S_2 \cdot 0 + 184.13 \text{ kg/hr} \cdot 0.472 = 4.92 \text{ kg/hr} \cdot 0.9134 + M_2 \cdot 0.423 \dots (8)$$

$$M_2 = 195 \text{ kg/hr}$$

Thus, the average value of steam that enters into the predistillation column ( $S_2$ ) is calculated from equation 6 as follows;

$$S_2 + 184.13 \text{ kg/hr} = 4.92 \text{ kg/hr} + 195 \text{ kg/hr} \dots (9)$$

$$S_2 = 15.8 \text{ kg/hr} \quad (\text{Ans.}) \dots (10)$$

**c) Rectification Column:** With similar techniques, the average amount of steam used in the rectification column was calculated as shown below. Here the final product (fine alcohol) is included in computational process.

$$S_3 + M_2 = P + F_3 + W_2 \quad \text{-----(11)}$$

$$S_3s_3 + M_2m_2 = Pp_f + F_3f_3 + W_2w_2 \quad \text{-----(12)}$$

Equations 11 and 12 were used to calculate the average values of the steam applied into the rectification column and final product to be collected.

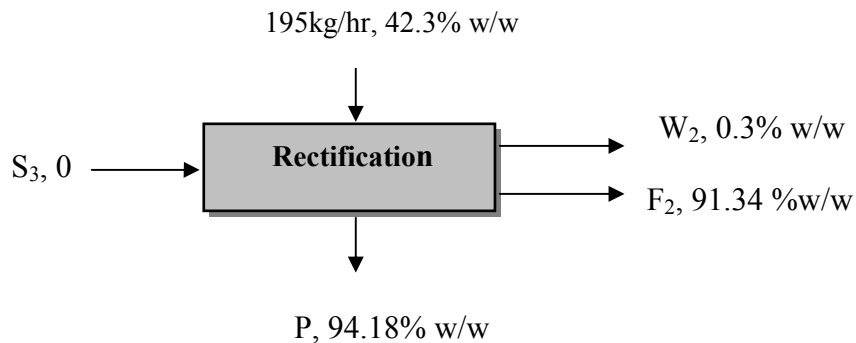

From equation 12, the average production of fine alcohol is calculated as follows;

$$S_3*0 + 195\text{kg /hr}*0.423 = P*0.9418 + 3.28\text{kg/hr}*0.9134 + 393.82\text{kg/hr}*0.003 \quad \text{----- (13)}$$

$$P = 83.22 \text{ kg/hr} = 104.82 \text{ lt/hr} \quad \text{----- (14)}$$

It is larger than actual production. The loss was due to flashing after condensers and losses with spillage and spent wash, because the alcohol content measured during onsite visit could only be used as indicative.

Using equation 11 and 14;

$$S_3 + 195\text{kg/hr} = 83.15 \text{ kg/hr} + 3.28\text{kg/hr} + 393.83\text{kg/hr} \quad \text{-----15)}$$

$$S_3 = 285.25 \text{ kg/hr} \quad \text{(Ans.)} \quad \text{----- --16)}$$

The total steam requirement for the distillation purpose is the sum of the steams used in the separated columns. Therefore; average total steam from equations 5, 10 and 16, we get;

$$S_1 + S_2 + S_3 = 83.3 + 15.8 + 285.25 = 384.38 \text{ kg/hr} \quad \text{(Ans.)}$$

The flow rate of the beer into the mash column is 1300 lt/hr, and requires about 26.1 hours to distill the clarified beer (33,891.3 liter). Therefore, the total steam demand is about 10,032.3 kg to

produce 2348 liters of alcohol (96°GL) per day. This is only 0.8 % less than that is calculated in table 18.

### 5.2.3.1 Alcohol Balance

The alcohol balance for the plant was calculated based on information from the total mass balance in table 18 above.

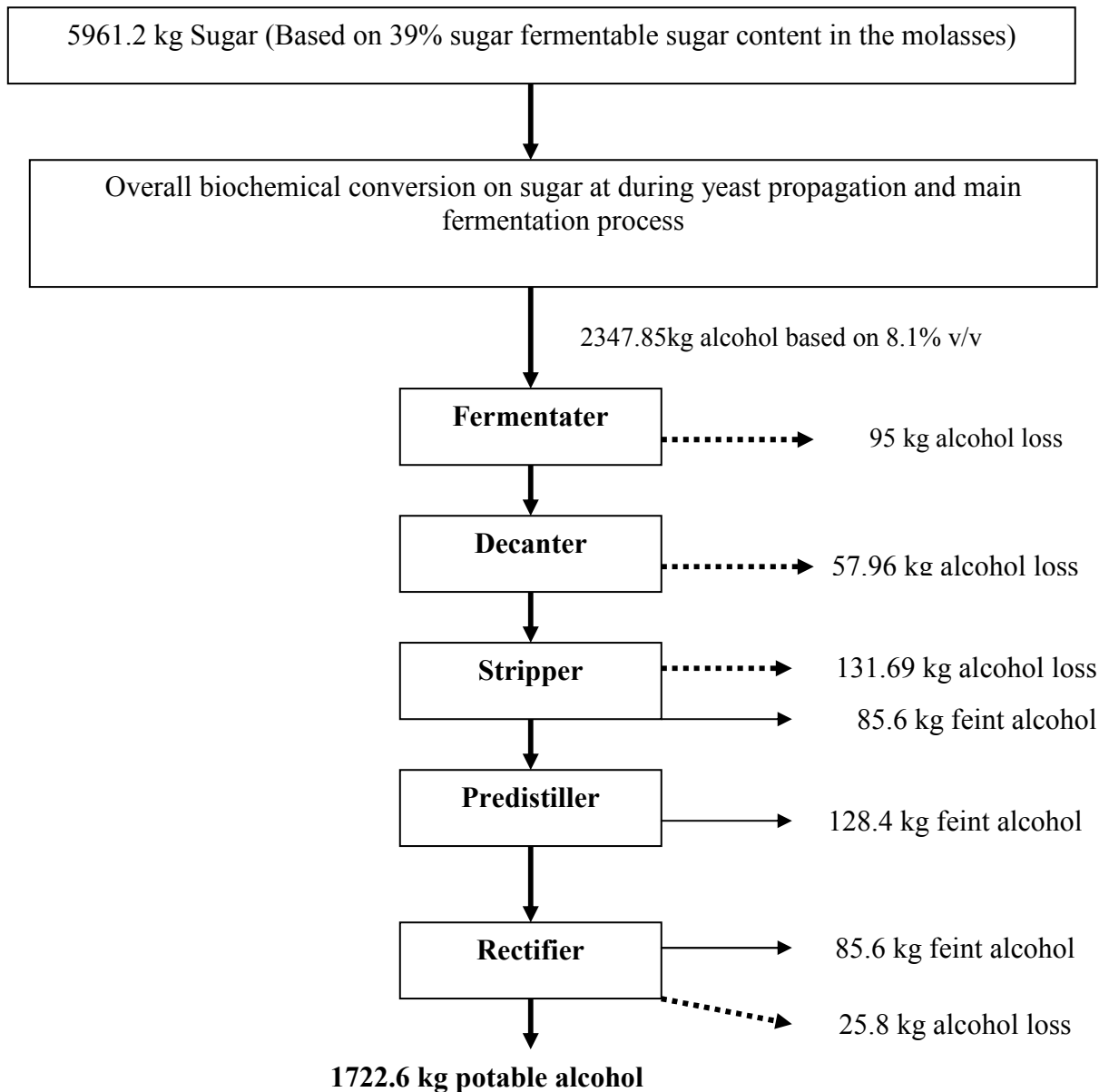

**Figure 6** -Mass balance for alcohol production

### 5.2.3.2 Energy Balance

From literature survey, it is known that a distillery plant consumes more steam energy than electrical energy. Similarly, in SALF the numbers of appliances that use electrical energy are few: one new compressor that automatically opens and close, seven pumps and 32 fluorescent lambs. Therefore, the CP- EE assessment was focused mainly on the thermal energy utilization.

At current operation, the only available data to formulate energy balance at generation and distribution sides are the fuel consumption and the feed rate of the beer to the distillation column. This required measuring many important parameters onsite in order to develop energy balance and generate intervention options. These include measuring the flue gas composition using gas analyzer, measuring surface temperatures of steam pipes and columns, and quantities such as condensates at various sites necessary to evaluate the energy efficiency of the distillery.

#### General information

##### 1. a) Operating Boiler

Type	:	Fire Tube
Make	:	VAPOMATIC
Manufacturer	:	ALBERTI
Years of manufacturing	:	1980
Rating (kg/hr)	:	2000 @ 15 bar
Fuel type	:	Light fuel oil
Use	:	Process boiler
Operating pressure (bar)	:	8.5 -10.5 (average 9.0)
Burner type	:	VAPOMATIC

**b) Stand -by Boiler** (data are not available)

## 2. Other Information in Boiler House

Availability of Measuring Devices and Instruments	Status		Comment
	Yes	No	
<b>Flow metering</b>			
Fuel	√		Not working
Steam		√	
Boiler feed water		√	
Air	√		Not working
<b>Temperature measuring</b>			
Steam		√	
Fuel	√		Operates 85 – 100°C
Feed water	√		Operates 80 – 90°C
<b>Pressure measuring</b>			
Steam	√		Operates 8.5 – 10.5 bar
Fuel	√		Operates at 2 bar
<b>Safety Equipments and Instrumentation</b>			
Boiler	√		Automatic
Burner	√		Automatic
Water system	√		Automatic
Fuel system	√		Manual
Steam distribution		√	

### 5.2.3.2.1 Steam Generation

#### Heat Gains

The sources of heat for the boiler are fuel oil, combustion air, make-up water and condensate. At present there is no steam condensate returning to the boiler.

#### Heat Gain from Combustion Air

Since the flue gas is analyzed based on ambient temperature, the heat gained from cold air is assumed zero.

### Heat gain from oil combustion

The average hourly fuel consumption is 48.3 l/hr (company data). Therefore energy gained from fuel oil;

$$\begin{aligned} &= M_f (\text{kg/hr}) * 48 \text{ MJ/kg} \\ &= 48.3 \text{ l/hr} * 0.93 \text{ kg/l} * 48 \text{ MJ/kg} \\ &= \mathbf{2156 \text{ MJ/hr}} \end{aligned}$$

### Heat Gain from Feed Water

In current operation, there is no installed instrument measuring the quantity of feed water entering the boiler. The feed water is heated with steam taken directly from the boiler. Therefore, with some uncaught losses due to steam and preheated feed water, this quantity of heat will be cancelled out during energy balance calculation.

### Heat Loss

#### Heat Loss in Flue Gas

Using the flue gas analyzer (KANE KM9104), the operating boiler has been analyzed for its combustion efficiency in terms of heat losses in flue gas. The analyzer results are given in Table 19.

**Table 19 -Results of combustion analyzer before Adjustment**

Operating pressure (bar)	Excess air (%)	O <sub>2</sub> (%)	CO <sub>2</sub> (%)	CO (ppm)	T <sub>a</sub> (°C)	T <sub>f</sub> (°C)	T <sub>net</sub> (°C)	q <sub>d</sub> (%)	q <sub>w</sub> (%)	q <sub>co</sub> (%)	q <sub>T</sub> (%)	G (%)
8.5	919	18.8	1.5	537	29	233	204	65	7.3	0.2	72.5	26.7
9.0	760	18.4	1.8	1127	30	229	204	60	7.3	0.4	67.7	39.4
9.5	904	18.8	1.5	502	30	235	204	63.6	7.3	0.1	70.9	29.0
10.0	994	18.9	1.4	492	30	238	207	66.2	7.3	0.1	73.2	26.4
10.5	1572	19.9	0.9	413	31	210	179	69.3	7.3	0.1	76.5	23.5
<b>Average</b>	<b>1030</b>	<b>18.7</b>	<b>1.42</b>	<b>614.2</b>	<b>30</b>	<b>229</b>	<b>200</b>	<b>64.8</b>	<b>7.3</b>	<b>0.18</b>	<b>72.2</b>	<b>29.0</b>

Where: O<sub>2</sub> = measured oxygen content referenced to 3%

CO<sub>2</sub>= Calculated Carbon dioxide content from O<sub>2</sub> content

CO = Measured carbon monoxide Content.

T<sub>A</sub> = Ambient air temperature ( °C)

T<sub>F</sub> = Flue gas temperature ( °C)

T<sub>net</sub> = net temperature between flue gas and ambient air ( °C)

G = Gross efficiency of combustion

q<sub>w</sub> = dry loss (%), loss due to water vapors

CO = loss due to incomplete combustion.

**Equations:-**

$$\text{CO}_2 = \frac{[20.9 - \text{Measure O}_2] * K_2}{20.9}$$

**Efficiency Calculation**

$$\% \text{ dry flue gas gross loss} = 20.9 K_{lg} * \frac{T_n}{K_2} * (20.9 - \text{measured O}_2)$$

$$\% \text{ dry flue gas net loss} = 20.9 K_{lg} * \frac{T_{an}}{K_2} * (20.9 - \text{measured O}_2)$$

$$\% \text{ dry flue gas loss} = K_3 * (0.001 * T_n) + 1$$

$$\% \text{ CO loss} = K_4 * \left\{ \begin{array}{l} \% \text{CO} \\ \% \text{CO} + \% \text{CO}_2 \end{array} \right\} \quad \text{where } \% \text{ CO} = \text{CO}_{\text{ppm}} * \frac{20.9}{20.9 - \text{O}_2}$$

Gross efficiency = 100 Dry loss gt wet loss - CO loss

Net loss = 100 - Dry loss (n) CO loss?

Where K<sub>lg</sub> = Gross calorific value at light fuel oil

K<sub>ln</sub> = net calorific of light fuel oil

K<sub>2</sub> = % theoretical max % CO<sub>2</sub> of light oil

K<sub>3</sub> = % Assumed net loss

K<sub>4</sub> = Alpha Value (32 - 48)

Thus, it is possible to check the analyzer outputs in table 19 using the formulae given above. It is almost the same! Therefore, the overage stack loss q<sub>t</sub> = 72.2% (very high)

### Combustion efficiency

The average gross combustion efficiency from table 19 is 72.2%. However, Combustion efficiency do **NOT** include losses in radiation and convection from boiler surface (1-4% theoretically), blow down and others. Therefore, the boiler efficiency would be smaller than given in the table.

**Comment:** The boiler has very low combustion efficiency due to the average excess air ratio of 1030%, well above recommended excess air requirement of 17%.

Therefore, after one week the boiler was adjusted using the same instrument for excess air and it was able to achieve a combustion efficiency of 84 % as shown in table 20 below.

**Table 20 - Results of Combustion Analyzer after Adjustment**

Operating pressure (bar)	Excess air (%)	O <sub>2</sub> (%)	CO <sub>2</sub> (%)	CO (ppm)	T <sub>a</sub> (°C)	T <sub>f</sub> (°C)	T <sub>net</sub> (°C)	q <sub>d</sub> (%)	q <sub>w</sub> (%)	q <sub>co</sub> (%)	Q <sub>T</sub> (%)	G (%)
8.5	45	6.5	10.7	401	28	225	196	8.8	7.3	0.1	72.5	83.8
9.0	35.7	5.5	11.6	453	29	227	198	8.3	7.3	0.13	67.7	84.2
9.5	32	5.3	11.6	363	27	230	203	8.45	7.3	0.1	70.9	84.15
10.0	37.5	5.65	11.3	360	27	232	205	8.7	7.3	0.1	73.2	83.9
10.5	40	6.0	11.05	348.5	27.5	234	207	8.95	7.3	0.1	76.5	83.7
<b>Average</b>	<b>38.04</b>	<b>5.79</b>	<b>11.25</b>	<b>385.1</b>	<b>27.7</b>	<b>230</b>	<b>202</b>	<b>8.64</b>	<b>7.3</b>	<b>0.11</b>	<b>16.1</b>	<b>83.95</b>

### Estimation of Other Heat Losses

In SALF, other sources of heat loss during energy generation other than heat loss with flue gas include steam losses through blow down and gauge clearing and boiler surface losses through radiation and convection. These values are estimated from data collected during onsite monitoring.

### Heat Losses with Steam before Pressure Gauge and Sensors

The pressure gauge and sensors mounted on the body of the boiler work properly only if a wet steam does not interfere with their function. Therefore, some part of steam from the boiler is continuously let out and sometime the process is enhanced by the operators. The heat loss due to this operation is estimated to be 1.5 % of the total heat produced.

### Heat Loss during Blow down (BD)

The blow down of steam from the boiler to reduce scaling problem is another activity which is conducted with less care at current boiler house operations. It is the operators' decision whether to blow down or not. It is known from the operators that blow down is done once every two hours. The energy loss due to blow down is also estimated to be 2% of the total energy produced.

### Heat Loss from Boiler Surface

The existing boiler is 21.63 m<sup>2</sup> in area. The average surface temperature measured was 47 °C. Based on these data, the heat loss due to radiation and convection was calculated and found to be 14.13 MJ/hr.

### Energy Balance Before Adjustment for excess air

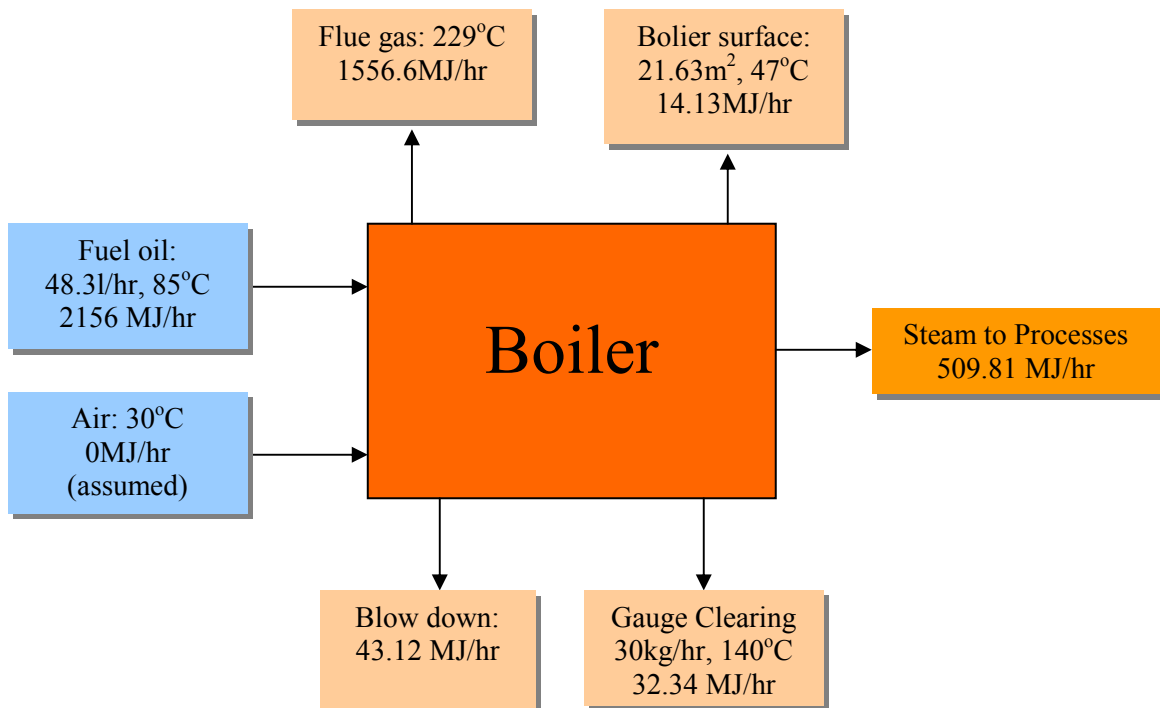
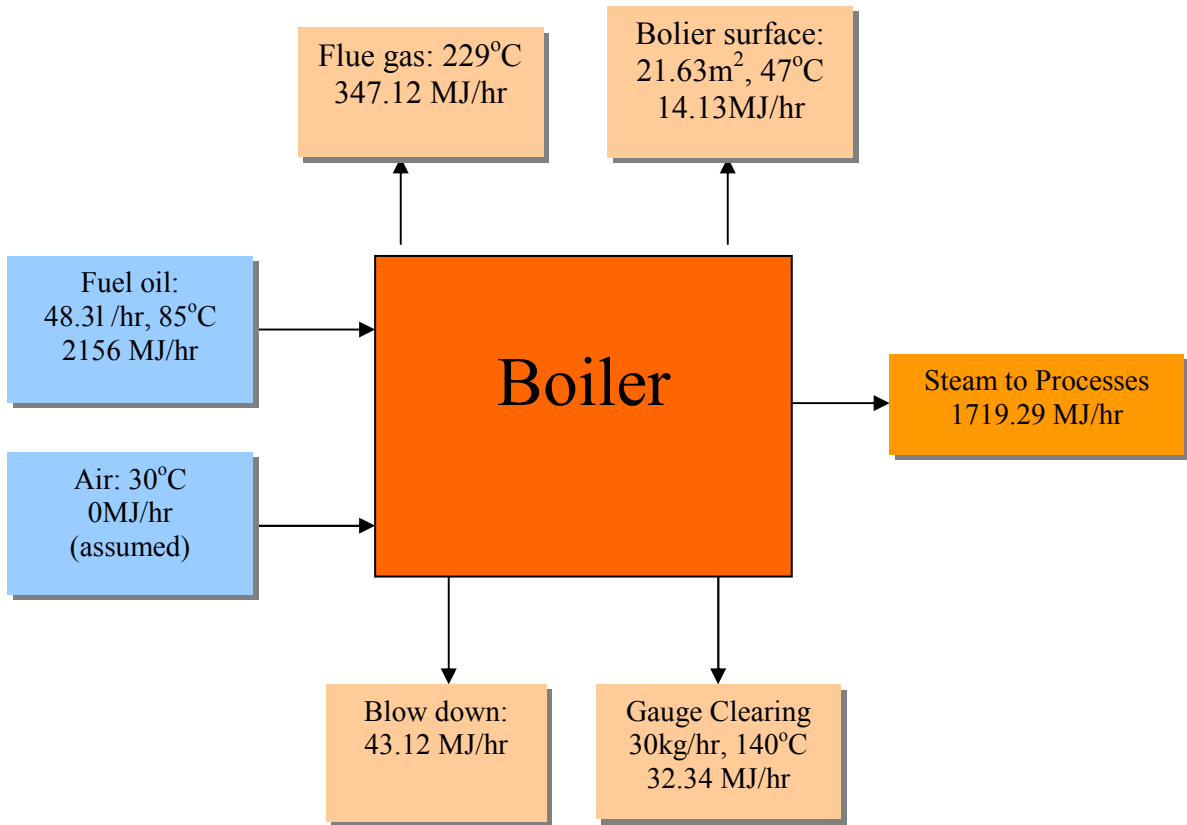

Figure 7 -Energy Balance before adjustment for excess air

### Energy Balance After Adjustment for excess air

In this case, the heat loss in the flue gas is reduced to 16.1%. Considering the heat losses through other factors are constant, figure 9 depicted that the output energy increased by 70.4 % compared to figure 8.



**Figure 8** -Energy Balance after adjustment for excess air

### 5.2.3.2.2 Steam Distribution and Demand

#### Heat Loss from Hot Pipes and Uninsulated Columns

At current operation, all steam pipes and distillation columns are not insulated. Therefore, it is expected that large amount of energy is lost through radiation and convection to the surrounding air due to temperature gradient. This amount was calculated based on data in table 21 below and calculated to be 1171.11 MJ/day.

Table 21- Parameters of Steam Distribution Pipes and Distillation Columns

Component	Diameter (mm)	Length (m)	Surface * temperature (°C)	Others
Main line from boiler to steam header	88.9	9.9	161	3 elbows and 3 steam valves
Main line from boiler to distillation section	88.9	24.57	161	4 elbows, 4 flanges
Steam line from main line to mash column	42	1.46	145	3 elbow, 1 flange and 1 valve
Steam line from main line to mash column	42	2.68	127	3 elbow, 1 flange and 1 valve
Steam line from main line to mash column	42	5.08	127	3 elbow, 1 flange and 1 valve
Mash column	614.3	4.85	88	8 flanges
Predistillation column	614.3	3.95	70	6 flanges
Rectification column	614.3	9.5	68	11 flanges

### Heat Loss in Condensate

The average heat loss was calculated from measured condensate (70°C) flow rate.

$$\text{Condensate heat loss} = M_s h_f = 30 \text{ kg/hr} * 289.31 \text{ kJ/kg} = 8.68 \text{ MJ/hr}$$

### Steam (Energy) Requirements at Distillation Unit

Assuming a dryness factor,  $d_f = 0.96$ , and considering steam pressure drop, the energy requirement of each distillation column and the total thermal energy (from fuel burning) demand of the distillation house was calculated as follows;

#### Mash column

$$\begin{aligned} Q_1 &= m [(h_1 + d_f A) - h_L \text{ of the feed water}] \\ &= 83.33 \text{ kg/hr} * [(771.855 + 0.96 * 2777.9) - 359.93 \text{ kJ/kg}] \\ &= 256548.8 \text{ kJ/hr} = 256.55 \text{ MJ/hr} \end{aligned}$$

### **Predistillation Column**

$$Q_2 = 15.8 \text{ kg/hr} [771.855 + 0.96 * 2777.9] - 359.93 \text{ kJ/kg} \\ = 48643.6 \text{ kJ/hr} = 48.64 \text{ MJ/hr}$$

### **Rectification Column**

$$Q_3 = 285.25 \text{ kg/hr} * [771.855 + 0.96 * 2777.9] - 359.93 \text{ kJ/kg} \\ = 878201.74 \text{ kJ/hr} = 878.2 \text{ MJ/hr}$$

Therefore the total heat demand,  $Q_T = Q_1 + Q_2 + Q_3 = 1183.39 \text{ MJ/hr}$

Fuel Oil required at distillation house =  $\frac{1183.39 \text{ MJ/hr}}{48 \text{ MJ/kg}} = \mathbf{24.65 \text{ kg/hr}}$

### **Other Heat Losses in Distillation House**

At present heat recovery is being effected by passing the cold beer from the storage tank first through one condenser termed preheater, thereby raising its temperature to 62-68 °C (average observed value 64 °C). Therefore, an estimated 346 MJ/hr and 102.4 MJ/hr of heat energy are being lost through the stillage (90 °C) and spent lees (90 °C) respectively calculated as follows;

Heat in the stillage,  $Q_s = 1271 \text{ kg/hr} \times 4.19 \text{ kJ/kg} \cdot ^\circ\text{C} \times (90 - 64^\circ\text{C}) = 138.5 \text{ MJ/hr}$

Heat in the spent lee  $Q_L = 394 \text{ kg/hr} \times 4.19 \text{ kJ/kg} \cdot ^\circ\text{C} \times (90 - 64^\circ\text{C}) = 42.9 \text{ MJ/hr}$

## **5.2.4 Cost of Waste Streams**

Assigning costs to waste streams helps to understand the problem and potential savings. Costs of waste streams can be either cost of treating the waste or the money embodied in the lost material for purchasing and processing up to the point where it joined the waste stream.

As a prerequisite to assigning cost to waste streams, a detailed analysis of each waste streams must be carried out to assess the pollution load, thus Table 16 of page 51 depicted waste streams and pollution loads and table 22 below gives assigned costs.

**Table 22 - costs of waste streams**

Waste stream	Operation	alcohol		Water		Fuel		Other loss		Treatment		Total Birr /day
		Q (lt)	Cost <sup>†</sup> (Birr)	Q (m <sup>3</sup> )	Cost (Birr)	Q (lt)	Cost (Birr)	Q (kg)	Cost (Birr)	COD (kg)	Cost (Birr)	
<b>Process water</b>	Dilution	-	-	0.32	0.07	-	-	sugar	ND	2.934	2.934	3.01
	Fermentation	119.65	64.00	1.2	0.26	-	-	-	-	6.25	6.25	70.51
	Decantation	73	39.05	1	0.22	-	-	-	-	15.30	15.30	54.57
	Striping	165.86	391.72	28.56	6.28	-	-	-	-	682.87	682.87	1080.87
	Predistillation	-	-	-	-	-	-	-	-	-	-	--
	Rectification	32.49	76.74	10.86	2.39	-	-	-	-	~0	0	79.13
<b>Wash water</b>	Dilution	-	-	1.25	0.28	-	-	-	-	7.20	7.20	7.48
	Fermentation	-	-	0.64	0.14	-	-	-	-	1.81	1.81	1.95
	Floor wash	-	-	1.79	0.39	-	-	-	-	ND	ND	--
<b>Cooling water</b>	Distillation	-	-	345	76.0			-	-	-	-	69
<b>Air emission</b>	Fermentation	-	-	-	-			CO <sub>2</sub> 2777	2777	-	-	2777.00
<b>Energy</b>												
Uninsulation steam Pipes & columns	Steam generation & utilization	-	-	-	-	26.24	92.35	-	-	-	-	92.35
Poor combustion efficiency	Steam generation	-	-	-	-	1159.2	4080.4	-	-	-	-	4080.4
With stillage & spent wash	Waste discharge	-	-	-	-	97.5	343.3	-	-	-	-	284.24
Total cost of waste per day (Birr)												<b>8659.57</b>

-Treatment cost of 1kg COD is considered to be 1Birr and cost of alcohol was calculated based on raw material costs plus 5% overhead cost.

## 5.3 Phase II – Cause Evaluation & Option Generation

### 5.3.1 Cause Identification and CP-EE Option Generation

Based on the data collected through company document review, onsite monitoring and laboratory test results, a detail cause analysis was carried out for the various waste streams. There are many factors that influence the volume and composition of waste streams. In CP exercises, these causes are generally grouped as shown in figure 8 below.

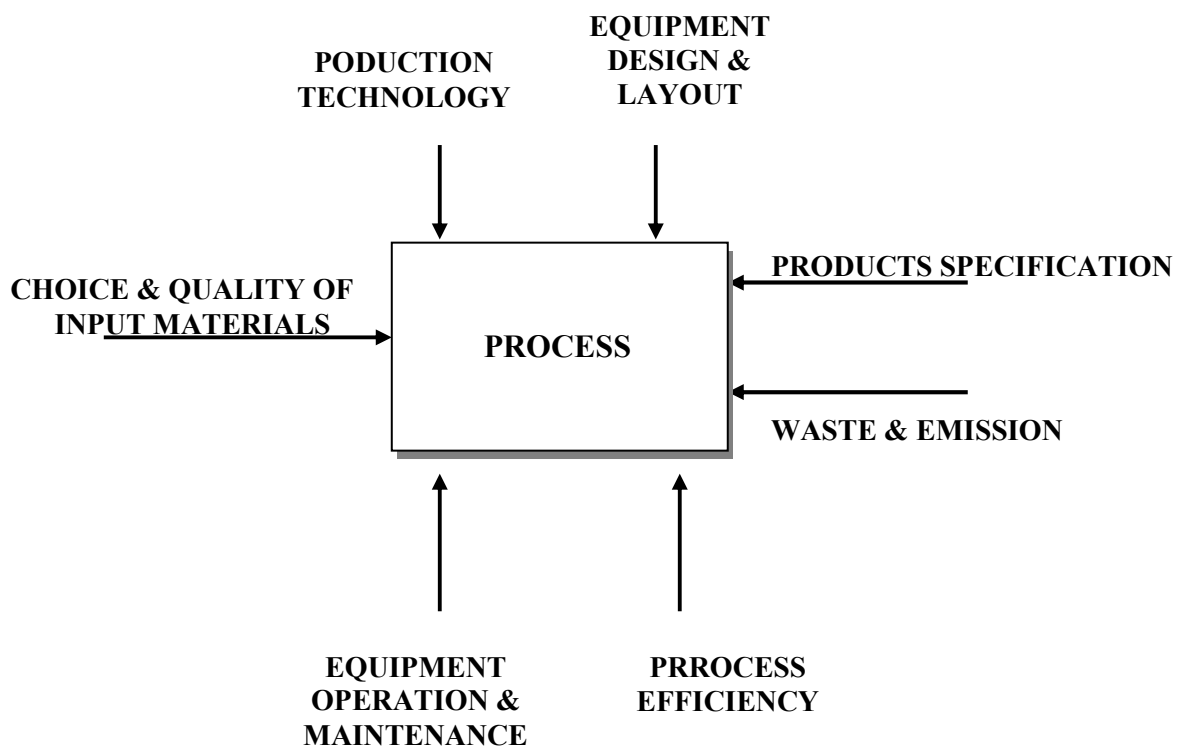

**Figure 9 -Cause Evaluation: Possible Causes of Waste Generations**

The cause analysis results along with the observations made during onsite monitoring were used for identification of respective CP-EE options to reduce resource consumption and environmental load. Table 21 summarizes these results.

**Table 23 - Cause Analysis and Generating CP-EE Options**

<b>Process Unit</b>	<b>Waste Streams</b>	<b>Probable Cause</b>	<b>CP-EE Options</b>
<b>Feedstock preparation</b>	Wastewater from mash preparation	<ul style="list-style-type: none"> <li>• No dilution procedure (recipe)</li> <li>• No flow meters to proportionate water and/or molasses</li> <li>• Erosion of the bottom floor of the vessels</li> <li>• Inadequate stirring at the bottom</li> </ul>	<p><b>1</b> Developing dilution work procedure (recipe)</p> <p><b>2</b> Installing water and/or molasses measuring flow meters.</p> <p><b>3</b> Regular maintenance of the vessel</p> <p><b>4</b> Optimizing the use of the air stirrer</p>
	Wastewater from dilution vessel washing	<ul style="list-style-type: none"> <li>• Repeated washing after each batch for fear of contamination</li> <li>• Use of low pressure water hose</li> </ul>	<p><b>5</b> Using a narrow metal nozzle to increase dynamic pressure of the water to improve washing efficiency and minimize water consumption</p> <p><b>6</b> Reducing dilution vessels washing frequency</p>
	Electrical energy loss	<ul style="list-style-type: none"> <li>• Pump is controlled from other building</li> </ul>	<p><b>7</b> Installing a separate pump control system for the feed preparation building.</p>
<b>Fermentation</b>	Wastewater from washing of mother fermenter and subsequent washing	<ul style="list-style-type: none"> <li>• Use of yeast inoculum to every batch / fermenter</li> <li>• No work instructions for vessel washing</li> <li>• Use of low pressure water hose</li> <li>• Erosion of the bottom floor of the vessels</li> </ul>	<p><b>8</b> Adopting yeast recycle system and a continuous fermentation process</p> <p><b>9</b> Developing clear work procedures for fermenter washing to save water</p> <p><b>10</b> Reuse the wastewater (sludge) as fertilizer</p> <p><b>11</b> Using a narrow metal nozzle to increase dynamic pressure of the water to increase washing efficiency and minimize water consumption</p>

	Wastewater from fermentation and subsequent washing	<ul style="list-style-type: none"> <li>No work instructions for vessel washing</li> <li>Erosion of the bottom floor of the vessels</li> <li>Use of low pressure water hose</li> </ul>	12	Conducting a regular maintenance to the fermenter
	Emission air	<ul style="list-style-type: none"> <li>CO<sub>2</sub> from fermentation reaction</li> </ul>	13	Developing clear work procedures for fermenter washing to save water
	Electrical energy loss	<ul style="list-style-type: none"> <li>Use of electric light when solar light is sufficient</li> </ul>	14	Installing CO <sub>2</sub> recovery system
Decantation	Wastewater from decantation	<ul style="list-style-type: none"> <li>No work instruction when/how to discharge sludge (continuously or at certain time interval )</li> </ul>	15	Increase the awareness of operators
	Alcohol with sludge	<ul style="list-style-type: none"> <li>Decantation time not enough</li> </ul>	16	Optimizing the decantation process by synchronizing with fermenter capacity and settling characteristic of the suspension in the beer.
Distillation	Condenser Cooling water	<ul style="list-style-type: none"> <li>No mechanism is devised to reuse the water</li> </ul>	17	Installing another decantation tank for providing extra time for settling
	Spent lee from rectification column	<ul style="list-style-type: none"> <li>No mechanism is devised to reuse the water</li> <li>Typical composition is not determined</li> </ul>	18	Reuse the cooling water
	Wastewater from mash column (stillage)	<ul style="list-style-type: none"> <li>No mechanism is devised to reuse the water</li> </ul>	19	Reuse spent lee as a process water
	Alcohol in the stillage and spent lee.	<ul style="list-style-type: none"> <li>Excessive feed rate of fermented beer</li> <li>Poor steam application</li> <li>Low alcohol recovery efficiency</li> </ul>	20	Recover the heat from the stillage
	Electrical energy loss	<ul style="list-style-type: none"> <li>Use of electrical light when solar light is sufficient.</li> </ul>	21	Reuse stillage as a process water
	Thermal energy loss	<ul style="list-style-type: none"> <li>Uninsulated distillation column</li> <li>Direct application of steam to the distillation columns</li> </ul>	22	Installing methane production unit
			23	Adjusting the operating pressure of the boiler
			24	Improve process controlling systems
			25	Increase awareness of operators
			26	Insulating the distillation column
			27	Installing indirect heating systems such as reboilers

<b>Boiler house</b>	Thermal energy loss in existing boiler	<ul style="list-style-type: none"> <li>• Malfunction air and thereby using very excess air</li> <li>• Fuel flow is not controlled</li> <li>• Old boiler</li> <li>• No procedure for blow down</li> <li>• Malfunctioning flue gas temperature monitoring thermometer</li> </ul>	<p>28 Repairing or replacing the existing air and fuel oil gauges</p> <p>29 Recovery of heat from flue gas for feed water heating</p> <p>30 Preparing a daily blow down log-sheet</p> <p>31 Repairing or replacing the flue gas temperature monitoring thermometer.</p>
	Thermal energy loss in steam distribution system	<ul style="list-style-type: none"> <li>• Uninsulated steam carrying pipelines</li> <li>• old and inefficient steam trap</li> </ul>	<p>32 Insulating steam distribution pipe system</p> <p>33 Repairing or replacing the steam trap</p>
	Feed water loss	<ul style="list-style-type: none"> <li>• Malfunctioning water level measuring floater</li> </ul>	<p>34 Repairing or replacing the water level monitoring floater</p>

## 5.4 Phase III - Evaluation of CP-EE Options

### 5.4.1 Screening of CP-EE Options

To decide on evaluation priorities, the CP-EE options generated were sorted through preliminary screening into “direct implementable”, “requiring feasibility analysis” and “requiring further study”. Table 24 gives the screening results.

**Table 24 - Screening the CP-EE Options Generated for implementation, Feasibility Analysis and further studies**

CP-EE option No.	CP-EE options	Direct implementable	Requiring feasibility analysis	Requiring further study
1	Developing dilution procedure (recipe)	√		
2	Installing water and/or molasses measuring flow meters.	√		
3	Regular maintenance of the vessel	√		

4	Optimizing the use of the air stirrer	√		
5	Using a narrow metal nozzle to increase the dynamic pressure of the water to improve washing efficiency and minimize water consumption	√		
6	Reducing dilution vessels washing frequency	√		
7	Installing a separate pump control system for the feed preparation building.	√		
8	Adopting yeast recycling system and continuous fermentation process			√
9	Developing clear work procedure for fermenter washing	√		
10	Reuse the wastewater (sludge) as fertilizer			√
11	Using a narrow metal nozzle to increase the dynamic pressure of the water to improve washing efficiency and minimize water consumption	√		
12	Conducting a regular maintenance to the fermenter	√		
13	Developing clear work procedure for fermenter washing			
14	Installing CO <sub>2</sub> recovery system		√	
15	Increase the awareness of operators	√		
16	Optimizing the decantation process by synchronizing with fermenter capacity and settling characteristics of the suspension in the beer			√
17	Installing another decantation tank for providing extra time for settling.	√		
18	Reuse the condenser cooling water		√	
19	Reuse spent lee as a process water		√	
20	Recover heat from the stillage		√	
21	Reuse the stillage as a process water			√

22	Installing methane production unit			√
23	Adjusting operating pressure from the boiler	√		
24	Improve process control systems	√		
25	Increase the awareness of operators	√		
26	Insulating the distillation columns	√		
27	Installing indirect heating system or using reboilers		√	
28	Repairing or replacing the existing air and fuel gauges	√		
29	Recovery of heat from flue gas to heat feed water			√
30	Preparing a daily blow down log-sheet	√		
31	Repairing or replacing the existing flue gas temperature monitoring thermometer	√		
32	Improving existing boiler efficiency	√		
33	Insulating steam distribution pipe system	√		
34	Repairing or replacing the water level control floater	√		

#### 5.4.2 Technical, Environmental and Economical Analysis of Selected CP Options

##### Option No. 14

**Option Title:** - Recovery of CO<sub>2</sub> at Fermentation Process Unit

##### Current Operation

At present the batch-mode fermentation unit in SALF is an open system where large amount of CO<sub>2</sub> is discharged directly to air at the top of fermenters. Operators and production supervisors express their discomfort of the suffocation effect due to the gas. On average, 2.8 tonnes of CO<sub>2</sub> are produced and emitted per day from the plant. As one of the greenhouse gases, CO<sub>2</sub> emission has to be reduced.

## **Proposed Operation**

The option proposed is to collect and treat reclaimed CO<sub>2</sub> to produce commercial products in terms of gas, solid or liquid CO<sub>2</sub>. Reusing CO<sub>2</sub> has been adopted in most breweries in Ethiopia. However, the CO<sub>2</sub> gas produced in the distillery fermentation process contains relatively more impurities such that the capital and operating costs are higher than those installed in breweries. Typical process flow diagrams of CO<sub>2</sub> plant is Appendix -3

The CO<sub>2</sub> produced can be used in soft drink industries, wineries and for filling fire extinguishers. By employing this option, over 560 tonnes of CO<sub>2</sub> per year can be recovered and the utilization ratio of raw material (molasses) increased by about 30%.

## **Assumptions**

The closure of the open fermentation system does not affect the fermentation process and markets are available for the CO<sub>2</sub> produced.

## **Advantages**

Besides its economical implication, the capturing and recovery of CO<sub>2</sub> will reduce the health impact on the operators and will reduce over 830 tonnes of the gas per year from going to the environment, thus contributing to the reduction greenhouse effect.

## **Concerns**

The closure of the open fermentation system raises the temperatures fermenters thereby an increase to the need for water for cooling the fermenters.

## **Economical Analysis**

The investment required is estimated at about 3.5 million Birr based on information collected from UNION Engineering (Denmark) and Gulali (India), but the annual expected revenue reaches 4.76 million Birr per year (i.e. calculated based on 8.5 Birr/kg of CO<sub>2</sub>). Therefore, the pay back period is only about 9 months.

## **Option No. 17**

### **Option Title: - Recycling Beer from Decantation sludge**

#### **Current Operation**

The fermented beer leaving the fermentation vessel is sent to a decantation tank of capacity 6000 lt. The suspension in the beer is allowed to settle for a while before the beer is transferred to temporary rectangular concrete storage tanks. It is customary to apply centrifuge to recycle beer. In SALF there is no such facility. Therefore, on average 195 liters of alcohol in the waste stream of 1m<sup>3</sup> is thrown into waste per day from decanter and fermenters. However, it is not always necessary to have a centrifuge; using additional decantation tank could increase the hydraulic retention time (HRT) of the beer in the decanters and reduce the loss.

#### **Proposed Operation**

Having additional decantation tank of size 12m<sup>3</sup> can increase existing average HRT (4hrs) to 12 and half hours. This is a simple unit that can be made onsite using available materials. It requires an investment cost of 6000 Birr with an estimated 50% recovery of alcohol from mentioned waste streams and 80 % distillation efficiency can save 30 liters of alcohol per day which is around 136,000 Birr/year

#### **Advantage**

By utilizing this option, product loss is reduced or raw material utilization efficiency will be increased and a more concentrated solid waste produced that can be used for land application as fertilizer.

## **Option No. 18**

### **Option Title: - Reuse Condenser Cooling Water**

#### **Current operation**

In current operation of SALF, the condenser cooling water constitutes over 90% of water consumption of the distillery plant. This cooling water is being sent as waste water directly to adjacent river. The cooling water goes through two concrete tanks of capacity 12.24m<sup>3</sup> before being discharged to the river. The existing cooling water system is depicted in figure 9 below.

## Proposed operation

To recycle condenser cooling water for the same purpose using a simple air cooling tower that operates at 10% make-up water to compensate evaporation loss and discharge to river for avoiding solid build-up. This option plans to bring into function the existing idle water tanks mentioned above. This technology is well known in many industries like breweries and soap factories in Ethiopia. The proposed cooling system as opposed to the existing once-through system is depicted in figure 10 below.

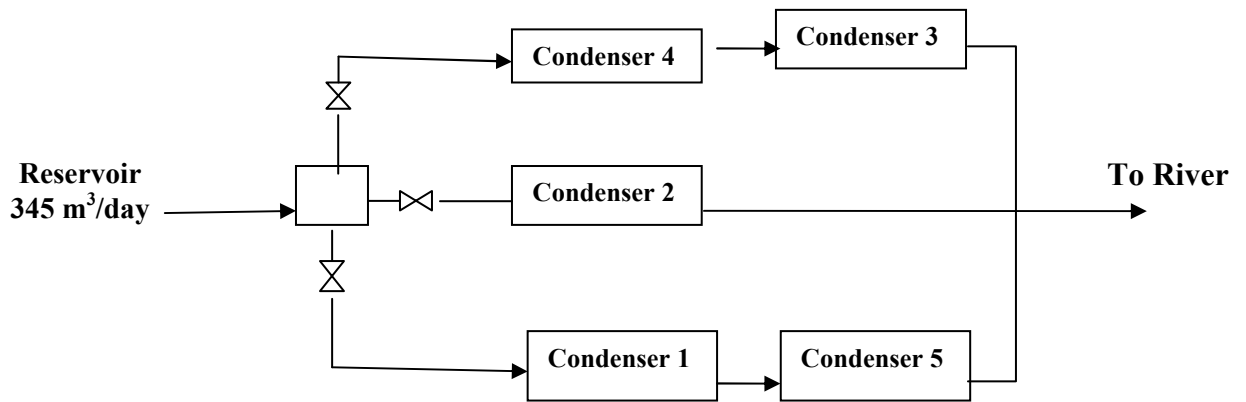

Figure 10 -Existing Condenser Cooling Water System

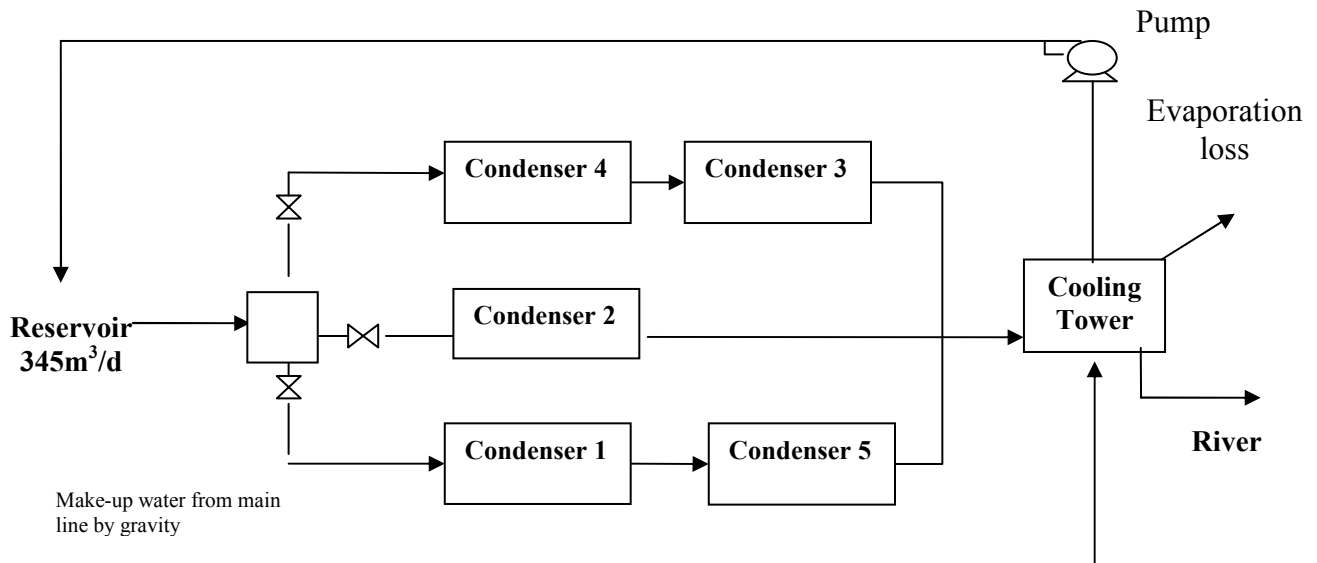

Figure 11 -Proposed Condenser Cooling Water System

## Advantages

Reduce condenser cooling water consumption by more than 85%.

## Economical Analysis

Category	Item	unit	Unit price	quantity	Total Price
<b>A. capital Cost</b>					
<b>Equipment</b>	Motors (0.5kWh)	pcs	2500	2	5000.00
	Belts	pcs	20	6	120.00
	Metal frames	m	30	50	1500.00
	1mx2mx3mm metal sheet	pcs	300	10	3000.00
	Wood frames	m	2.0	2126	4252.00
<b>Installation</b>	Construction	-	-	-	1000.00
	Installation	-	-	-	1000.00
	Utility connection	-	-	-	1000.00
<b>Contingency</b>	10%				1687.20
<b>Total Investment</b>					18559.20
<b>B.Operating cost</b>	Pumping Energy (kWh/year)	kWh	0.5573	7200	(4012.56)
	Water Saved (m <sup>3</sup> /year)	m <sup>3</sup>	0.22	93150	20493.00
Cost saving					16480.44
<b>C. Revenue</b>		-	-	-	

**Pay back period** = Investment /cost saving = 18559.20/16480.44=1.13 years

Then according to Mulholland (2006), the net present value (NPV) of a project will be calculated from the formula;

$$NPV = a \cdot I - b \cdot (CS + R) - c \cdot \Delta WC + d \cdot OTC$$

Where; I = Investment

CS = cost savings

R = revenue earned

WC= Work capital change

OTC = One time cost

And a, b, c and d are coefficients to be read from Appendix -4

Therefore, net present value (10 years, discount rate 10%)

$$\text{NPV} = -0.93 * 18559.20 - (-4.5) * (16480.44) = \mathbf{56,902 \text{ Birr}}$$

10 years and discount rate 25%

$$\text{NPV} = -0.8 * 18559.20 - (-2.3) * (16480.44) = \mathbf{23,057.7 \text{ Birr}}$$

10 years and discount rate 40%

$$\text{NPV} = -0.71 * 18559.20 - (-1.4) * (16480.44) = \mathbf{9,895.6 \text{ Birr}}$$

Even at high financial constraints, the option is feasible!!

## **Option No. 19& 20**

**Option Title:** - Ruse and Heat Recovery from Stillage and Spent lee

### **Current operation**

In the distillery, apart from the problem of boiler efficiency, the other problem pertains to the optimum recovery of heat in the distillation house. In current arrangement, the use of steam in the mash, predistillation and rectification columns, in feed water preheater and bottle washing vat is direct heating called open sparging from where there is no condensate return.

However, this method of using steam leads to a lot of heat loss in the stillage and spent lee from mash and rectification columns, on average a temperature of 90°C each. These bottom products are leaving the distillation house with average flow rates of 1190 and 395 liters per hour respectively.

The total average heat available in the stillage and spent lee are calculated as:

Heat in the stillage,  $Q_s = 1271\text{kg/hr} \times 4.19\text{kJ/kg} \cdot ^\circ\text{C} \times (90-25^\circ\text{C}) = 346\text{MJ/hr}$

Heat in the spent lee  $Q_L = 394\text{kg/hr} \times 4.19\text{kJ/kg} \cdot ^\circ\text{C} \times (90-25^\circ\text{C}) = 102.4\text{MJ/hr}$

### **Proposed operation**

From the point of view of optimum heat recovery from the above hot steams, it has been examined to what extent all the requirements of hot water in the distillery plant and the filling section can be met. The main such requirements are;

- I. Hot water to feed tanks of the boiler (see option No. 27)
- II. Bottle washing in the liquor filling section
- III. Dilution of High and Low Brix mash in feedstock preparation house

The first heat requirement is considered in option No. 27 below. The second and the third requirements are examined here.

### **Heat Recovery from Stillage**

Based on the water demand for the bottle washing (i.e. 500kg/hr at 60°C), the heat in the stillage is enough for the purpose. Assuming that the stillage after heating the bottle washing water will go to methantaion digester (as presented in option No. 22), the final temperature of the stillage is taken to be 50°C. This is achieved by using heat exchanger and using the heat transfer rate equation; the heat transfer area of the heat exchanger to carry out this purpose was calculated as 1.0m<sup>2</sup>

### **Assumptions**

Scaling in the heat exchanger due to solids in the stillage does not impact its average operation.

### **Advantage**

Reduce steam demand thereby reduction of fuel oil consumption and reducing the temperature of the stillage to 50°C which is suitable to thermophilic digestion that otherwise requires additional water for cooling or equalization tank.

### **Economical Analysis**

Based on data collected from the company and current market prices for the purchase of heat exchanger, pipe and fittings, a pump and including installation cost, the investment cost is estimated to be 52,000 birr. By doing so, the revenue that can be secured is calculated and found to be 41,630 Birr/year. This results in the pay back period of 1.25 years.

### **Reuse and Heat Recovery of Spent lee**

At current operation, the spent lee ( $9.5\text{m}^3/\text{day}$ ) leaving the rectification column is sent directly to the adjacent water stream. The spent lee is nearly a pure water, but with high temperature ( $90^\circ\text{C}$ ). Therefore, the proposed operation is to reuse this for the preparation of either High or Low Brix mash.

### **Assumption**

The composition of the water does not affect the biochemical process in the fermentation and yeast propagation process.

### **Advantages**

There are direct and indirect advantages. The direct advantage is the reduction of water consumption by  $9.5\text{m}^3/\text{day}$  (i.e. about 627 Birr/year), whereas since the pH of the spent lee is around 3.9, the acid requirement of the Low Brix mash will be reduced. Moreover, at higher temperature solids in the molasses precipitate thereby reducing scaling problem in the distillation process.

## **Options No - 22**

**Option Title** - Reuse the stillage to produce methane and fertilizer.

### **Current operation**

The stillage which is about  $29\text{m}^3$  per day with a BOD and COD levels of about 20,980mg/l and 53,514 mg/l respectively is directly drained into the adjacent river without any pretreatment. As per the Environmental Pollution Control Proclamation no. 300/2002, this high BOD/COD

wastewater can not be discharged without proper treatment. The limit of BOD for distilleries, according to this draft regulation for the enforcement of proclamation, is 60mg/l and a temperature of 40°C.

However, as stated in the introduction part, it is considered difficult to attain environmental standards by treating distillery wastes containing high BOD/COD content especially the stillage with conventional aerobic methods for these processes require high capital and operating costs and longer time that entails odor problems.

### **Proposed operation**

The proposed operation requires treatment of this high BOD/COD wastewater using anaerobic digester, particularly upflow anaerobic sludge blanket (UASB). Although anaerobic digestion is an end-of-pipe treatment process and hence would not normally be a preferred option under CP, compared to aerobic treatment methods it does have the advantages that it produces a valuable combustible gas- which can be used within the plant as source of energy thereby reducing the need for fossil fuels.

According to Stewart (2004), anaerobic processes have advantages in comparison with conventional aerobic and physico-chemical treatment processes that include;

- ☞ No aeration needed and thus low in energy demand
- ☞ Production of energy –rich biogas
- ☞ Very low production of residuals surplus sludge for final disposal
- ☞ Very high loading rates in terms of BOD/COD removal per unit installed reactor volume per day
- ☞ Free-odor as the processes takes place in closed tanks, etc.

There are four main designs of commercial high rate anaerobic processes: the contact process, the anaerobic filter, the fluidized bed reactor and the upflow anaerobic sludge blanket (UASB). In the first three treatment methods, the sludge wastewater contact is achieved either by mechanical mixing or by gas recirculation (in the case of contact process) or by using surfaces or carriers which act as supports on which bacterial attachment occurs (in the case of anaerobic filter and the fluidized bed reactors). Digesters based on these designs have several drawbacks. The contact process is similar to conventional aerobic activated sludge process where it requires

high energy for mechanical mixing, sludge settles with difficulty, and it has low organic loads of around 4-5kg COD/m<sup>3</sup>.day. Anaerobic filter digesters containing stationary supports are subject to clogging where as anaerobic fluidized bed reactors requires significant amount of energy to carry suspended high density particles such as sand.

The most widely used advanced design in developing countries like Brazil, India, Colombia and Venezuela is UASB, which was developed in late 1970's at Wageningen University, the Netherlands. This digester also uses a high concentration of bacteria but without the use of a support medium which gives a cost reduction over other anaerobic digesters discussed above. The key to its success has been the spontaneous formation of small 'granular bacterial pellets in the reactor that settle readily to the bottom of the reactor. Wastewater can be pumped relatively quickly through this reactor without loss of bacterial pellets, thus smaller reactors can be used that cost less than other non-UASB anaerobic digesters and treat effectively large volumes of wastewater because of the enhanced amount of active bacteria that are retained in the reactor.

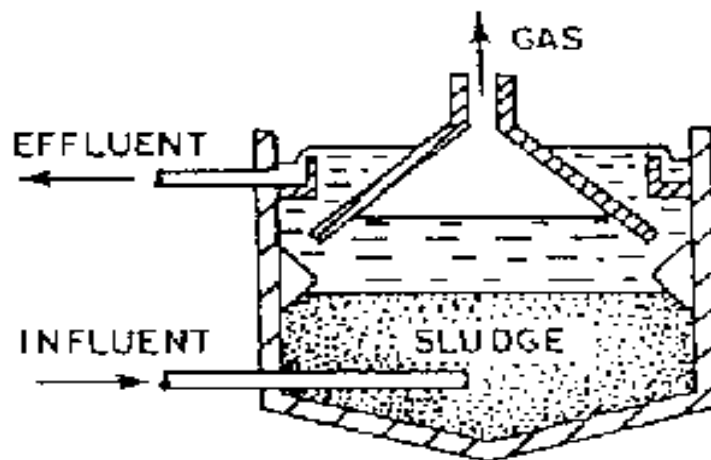

**Figure 12** - Upflow Anaerobic Sludge Blanket (UASB)

UASB system at mesophilic temperature (30-40°C) treating wastewaters with soluble and readily degradable BOD can be loaded up to 15-20kg BOD/m<sup>3</sup>.day, which is 2-3 times larger than complete stirred tank reactors (CSTR) whose loading rates ranges 6-7 kg BOD/m<sup>3</sup>.day. UASB systems provide even greater advantages in the thermophilic temperatures (50-70°C)

where they can be loaded up to 40-80 BOD/m<sup>3</sup>.day (Stewart, 2004). Hot wastewaters such as distillery stillage are readily treated with thermophilic UASB systems which can be even smaller and thus less expensive than respective systems operated at mesophilic conditions. **Table 25** shows USAB performance on stillage in India and Venezuela

**Table 25 - USAB performance on stillage (slop) in India and Venezuela**

Parameter	Unit	India	Venezuela
BOD removal	%	85	85-90
COD removal	%	65-70	65-70
Biogas yield	m <sup>3</sup> /kg COD removed	0.5	0.5
Loading rate	kg COD/ m <sup>3</sup> . day	10	16

Sources (Stewart, 2004)

Based on the design criteria such as reactor size and costs, surface loading rate and growth rate of micro-organisms, the UASB system is selected as an option to the case under study. In SALF, the distillery plant with a bath fermentation process generates 12-13 liters of stillage per liter of alcohol produced, which is about 28m<sup>3</sup> with 1498 kg COD/day. This is similar to the performance and yield of distillery in India. Therefore, based on the analyses presented on table 25 it is likely that a full scale UASB digester at SALF loaded with 10-15kg COD/m<sup>3</sup>.day (i.e. a reactor size of 100 - 130m<sup>3</sup>) will have BOD removal efficiencies in the vicinity of 85% and COD removal efficiencies of 65-70%.

### **Assumptions**

The composition of the stillage must be thoroughly investigated and check that the concentration of inhibitors is no so high to affect the process.

### **Advantage**

The advantage of applying the option includes;

- ☞ Methane emission reduction through its controlled recovery in an anaerobic digestion plant, otherwise methane will be emitted to the environment due to natural bioprocesses.

- ☞ Reduction of the need for fossil fuels thereby reducing emissions of CO<sub>2</sub> during combustion
- ☞ Production of by-products in the form of slurry or solids having potential to be used as fertilizer.
- ☞ Job creation and cost savings

### **Economical Benefits**

Financial analysis requires the knowledge of each and every details of the project. However, it is also possible to estimate investment costs from similar projects where capacities and costs are known. In this respect, it was not possible to get such relevant data on investment requirements and operating costs for calculating payback period of the project. Only the possible income was estimated as shown below.

**Table 26 - Financial Analysis of Anaerobic Digestion Plant**

Upflow Anaerobic sludge blanket digester	
Location	Sebeta Alcohol and Liquor Factory
Feed rate	28m <sup>3</sup> / day with 1498 kg COD
Digestion temperature	50-60°C
Gas output	749 m <sup>3</sup> /day
Gas use	Steam generation
By-product	524 kg ( 65 % removal )
By-product use	Fertilizer
Capital cost	-----
Gas value (estimated in terms of fuel saved)	<b>378,994 Birr/year *</b>
By-product value	-----

\* 1m<sup>3</sup> methane gives 23MJ energy which is equivalent to 0.479 liters of light fuel oil. The current price of one liter of light fuel oil is 3.52 Birr

## Option No. 27

**Option Title:** - Installing Indirect Heating System Reboilers and Collecting Condensate

### Current Operation

The boiler in SALF is a process boiler where steam is directly applied and becomes part of the process. There is no means such as thermostatic control or pressure gauge to control the temperature and pressure of the steam entering to the columns. Therefore, operators have to adjust the steam pressure now and then manually. However, there were occasions where distillates flashed out even after condensers through the vent due to pressure fluctuation in the incoming steam and loss of alcohol. Figure 12 shows current steam generation, distribution and usage arrangement.

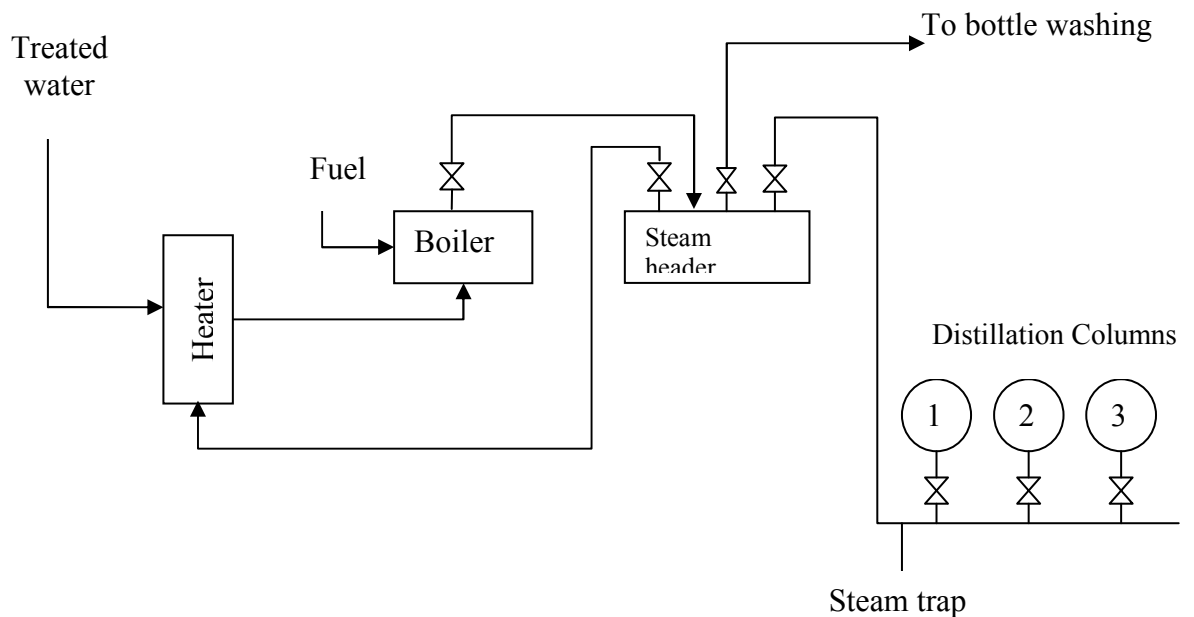
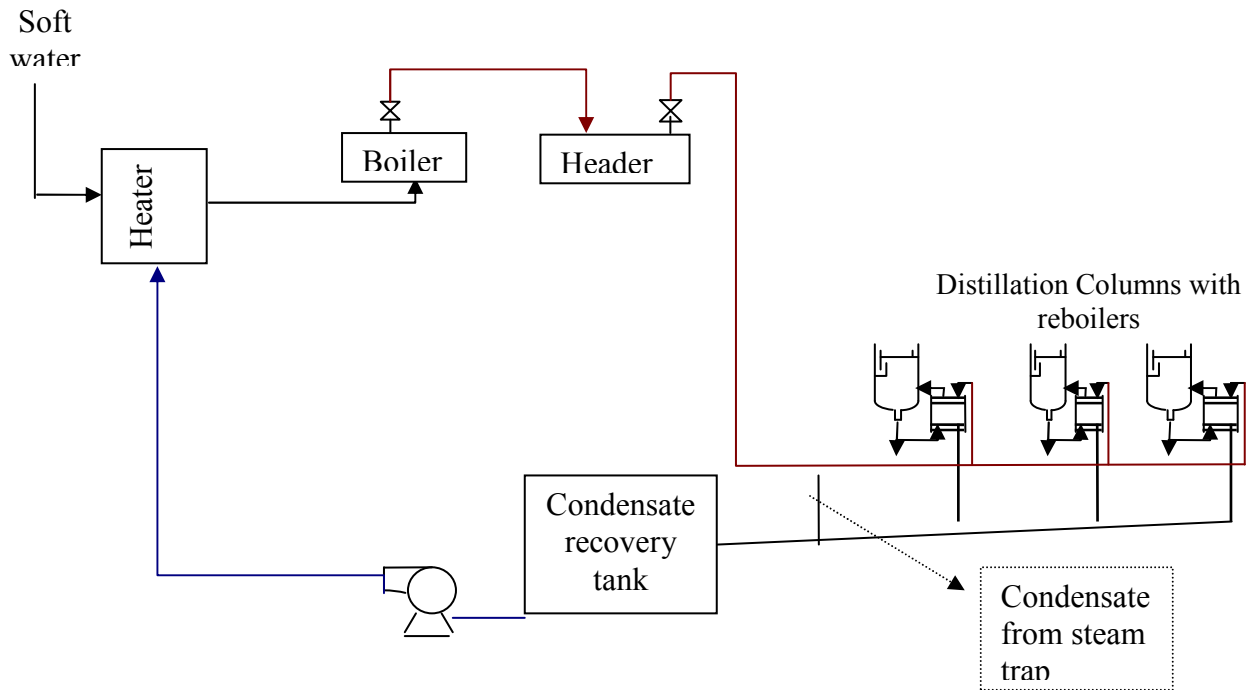

**Figure 13 - Existing Steam Generation and Distribution System**

### Proposed operation

Using an indirect heating system, steam can be returned as a condensate to supplement the feed water to the boiler. This can happen by using reboilers. Reboilers can be regarded as heat-exchangers that are required to transfer enough energy to bring the liquid at the bottom of the

column to boiling point. Using reboilers in distillation processes is a well established technology. The distillery in ‘Mechanisa’ branch of the same enterprise has been already using this arrangement. Together with options No.20, the proposed arrangement will be as shown below.



**Figure 14** -Proposed Indirect Heating and Condensate Collection Arrangement

**Advantage**

Reduce water and fuel consumption as well as increase process efficiency in the distillation unit. It will also reduce alcohol losses due to flashing resulting from pressure variation.

**Economical Benefits**

The proposed operation can reduce the daily fuel oil consumption by 63 liters that was used to preheat boiler feed water. In money value this will be more than 66,500 Birr per year. Of course, the saving is more than this if gains from water saving and others mentioned advantages are considered.

## Conclusions and Recommendations

### 6.1 Conclusion

- The raw material utilization efficiency of the factory at the distillery plant especially for molasses is low (6.3kg/lt of product). This can partly be attributed due to low content of fermentable sugar in the molasses (39%) and partly due to low fermentation efficiency (78.02%). Average fermentation efficiency elsewhere is 88.86%.
- The overall alcohol conversion efficiency of the distillery of 65% is also low compared to achievable benchmarks of 85%.
- The water consumption of the distillery is 168 liter per liter of product, which is in the range of literature values. In the factory, generally there is no any practice to reuse waste water.
- The steam consumption of the present arrangement in the distillation unit is 4.13kg/liter of 96°GL alcohol (i.e. about 8.3MJ) which is in good agreement to the literature values, but due to various heat losses during generation and distribution of steam the overall energy consumption of the plant (more than 22 MJ/liter of product) is still very high.
- The environmental pollution load due to discharges from the factory is very high (i.e. BOD is 20,867 mg/l and COD is 53, 514 mg/l) compared to the draft standards set for the Industrial Pollution Prevention and Control Proclamation No.300/2002.

- Process control and monitoring activities are generally low in the factory such that there is no regular maintenance to process control equipment units and there are no procedures for vessel washing and discharging.
- Carrying out improvements that can be implemented directly, the plant can reduce wastes and achieve savings of Birr 476,000/year.
- By conducting further in-depth feasibility studies on options identified, the plant can reduce wastes significantly and earn additional income of Birr 5.3 million/year from savings generated through better resource utilization.

## **6.2 Recommendation**

- The management of the factory should implement the ‘low hanging fruits’ of the CP Options recommended shortly and embark on considering studies on identified issues for implementation as a continuous improvement exercise.
- The CP effort is in principle a never ending process where there will always be new opportunities to improve production efficiency and reduce environmental impacts. This will require an organized and on-going cleaner production assessment practices. To this end, implementing an Environmental Management System (EMS) in the NALF is important to give a structural framework across the firm for continual improvement for the technical solutions raised through CP techniques.
- Instrumentation that enables proper process control and monitoring should be made available in order to measure key parameters and performance indicators for better environmental management and resource utilization.
- NALF should first implement the simpler CP options thereby reducing the wastes and the related environmental load of its discharges and then embark on the design and

implementation of the end-of-pipe (EOP) wastewater treatment. This is necessary in order to recover as much resource as possible thereby reduce the environmental load for minimizing both the investment and operating costs of the EOP treatment unit that would be essential eventually for meeting regulatory standards.

### **6.3 Potential for Further Research and Assistances**

- ☞ In this project work, it is found that the efficiency of the distillery at the fermentation unit is low and the factory applies relatively old technology compared to distilleries using the same raw materials (molasses). More investigation for improvement of fermentation efficiency is recommended
- ☞ Currently, the distilleries at SALF and Mechanisa Branch of NALE use three-tower distillation arrangement nearly at normal pressure. This process consumes a large amount of steam. Restructuring this arrangement in such a way to create a pressure differences among different distillation columns (towers) is expected to save substantial amount of heat from bottom products and alcohol vapors. This point needs further study and consideration.
- ☞ This work illustrated that distilleries produce large amount of organic load that can have a potential for biogas generation and fertilizer. However, the potential must be supported with further research so that constituents are exactly identified and appropriate technologies selected.