



**ADDIS ABABA INSTITUTE OF TECHNOLOGY**

**ADDIS ABABA UNIVERSITY**

**ECONOMICAL SPAN COMBINATION AND SECTION FOR A THREE SPAN**

**CONTINUOUS POST-TENSIONED CONCRETE RAILWAY BRIDGE**

**DEREJE GUDETA**

MAY 2015

**ECONOMICAL SPAN COMBINATION AND SECTION FOR A THREE SPAN CONTINUOUS  
POST-TENSIONED CONCRETE RAILWAY BRIDGE**

By

**Dereje Gudeta**

A Thesis Submitted to

Addis Ababa Institute of Technology,

Addis Ababa University

In

Partial Fulfillment of the

Requirements for the Degree of

MASTER OF SCIENCE

In

CIVIL ENGINEERING

**Approved by Board of Examiners**

Dr. Abrham Gebre

\_\_\_\_\_

\_\_\_\_\_

Advisor

Signature

Date

Dr.-Ing. Girma Zerayohannes

\_\_\_\_\_

\_\_\_\_\_

Internal Examiner

Signature

Date

Dr. Asnake Adamu

\_\_\_\_\_

\_\_\_\_\_

External Examiner

Signature

Date

\_\_\_\_\_

\_\_\_\_\_

\_\_\_\_\_

Chairperson

Signature

Date

## **ACKNOWLEDGMENTS**

I would like to express my deepest gratitude to Dr. Abrham Gebre for his valuable guidance and advices.

I also owe deepest gratitude to Ethiopian Railways Corporation (ERC) for covering all the expenses during my stay at the Addis Ababa Institute of Technology.

Finally, I would like to thank those who have been supporting me in different ways throughout the study period.

## ABSTRACT

Significant traffic and congestion across urban areas, as well as waterways, create a demand for long-span bridges. The construction of these longer spans plays a critical role in the development of modern infrastructure due to safety, environmental, and economic reasons. A variety of bridge construction practices have been observed over the years. Planning, design and construction techniques are revised and refined to satisfy several parameters including feasibility, ease of construction, safety, maintainability, and economy. In Ethiopia, Reinforced Concrete bridges are commonly used for highways because of their ease of construction, availability of construction materials, low construction cost, etc. The bridges being built using reinforced concrete are most commonly used for full length, simply supported spans. However, there has been a growing need in the transportation sector to build bridges with longer spans, for instance, to construct elevated carriageways (for railways) in congested urban areas due to limited spaces and right of way. The ordinary reinforced concrete bridges for extending span ranges with incremental variations in the materials and conventional design procedures often result in relatively small increases in span range due to limited strengths and excessive deflections. These challenges would dictate to search for alternative materials and design philosophy, i.e. the Prestressed Concrete. Consequently, prestressed post-tensioned concrete continuous girder bridges will be discussed in detail in this research using different sections.

This thesis has assessed the cost-effectiveness (economic feasibility) of a three span continuous post-tensioned concrete railway bridge superstructure using Box and T-Girder sections for different span combinations. Summary of the results has showed that the economical span combination of a three span continuous post-tensioned railway bridge with a span of 100.00m is found to be 32.00 – 36.00 – 32.00m (L – 1.13L - L) for Box Girder, and 29.00 – 42.00 – 29.00m (L – 1.45L – L) for T-Girder. The study has also revealed that box girder sections are economical than the T-girder sections for a three span continuous post-tensioned railway bridge with a span of 100.00m.

## LIST OF SYMBOLS

$A$  = gross area of Section

$A_{gb}$  = gross area of the bearing plate

$A_s$  = area of non-prestressed tension reinforcement

$A_s^*$  = area of prestressing steel

$A_{sr}$  = steel area required to develop the compressive strength of the web of a flanged section

$A_v$  = area of web reinforcement

$b$  = width of flange of flanged member or width of rectangular member

$b_w$  = web width

$b'$  = width of a web of a flanged member

$B$  = buoyancy

$CF$  = centrifugal Force

$CR_c$  = loss of prestress due to creep of concrete

$CR_s$  = loss of prestress due to relaxation of prestressing steel

$D$  = dead load

$D$  = degree of curve

$d$  = distance from extreme compression fiber to centroid of the prestressing force

$d_d$  = outside diameter of post-tensioning duct

$d_t$  = distance from the extreme compressive fiber to the centroid of the non-prestressed tension reinforcement

$E$  = earth pressure

$E_a$  = actual super elevation

$e$  = base of Napierian logarithms

$e_p$  = prestressing strands eccentricity

$E_c$  = modulus of elasticity of concrete

$E_{ci}$  = modulus of elasticity of concrete at transfer

$E_s$  = modulus of elasticity of prestressing steel

$E_{si}$  = modulus of elasticity of steel reinforcement

ES = elastic shortening of concrete

$f_b$  = bottom fiber stress in concrete

$f_{br}$  = concrete bearing compressive strength

$f'_c$  = compressive strength of concrete at 28 days

$f'_{ci}$  = compressive strength of concrete at time of initial prestress

$f_{cir}$  = average concrete stress at the center of gravity of the prestressing steel at time of release

$f_{cds}$  = average concrete compressive stress at the center of gravity of the prestressing steel under full dead load

$f_d$  = stress due to unfactored dead load, at extreme fiber of section where tensile stress is caused by externally applied loads

$f_{se}$  = effective prestress

$\Delta f_s$  = total prestress loss, excluding friction

$f_t$  = top fiber stress in concrete

$f_{fi}$  = friction loss in post tensioned members

$f_{pe}$  = compressive stress in concrete due to effective prestress forces only

$f_{po}$  = stress in the prestressing tendon at the jacking end

$f_r$  = modulus of rupture of concrete

$f'_s$  = ultimate strength of prestressing steel

$f_{se}$  = effective stress prestress after losses

$f_{sy}$  = yield strength of non-prestressed conventional reinforcement in tension

$f^*_y$  = yield point stress of prestressing steel

$f^*_{su}$  = average stress in prestressing steel at ultimate load

F = longitudinal force due to friction or shear resistance at expansion bearings

FR = friction loss

h = total depth of section

$h_{min}$  = minimum structural depth

$h_{max}$  = maximum structural depth

I = impact load

ICE = ice pressure

$K$  = friction wobble coefficient  
 $K_s$  = a constant for the determination of a stream pressure  
 $l$  = length of prestressing steel  
 $L$  = the span length in meters  
 $LF$  = longitudinal force from live load  
 $LL$  = live load  
 $M_1$  = primary moment  
 $M_{\text{balanced}}$  = balanced load moment  
 $M_{cr}$  = moment causing flexural cracking at section due to externally applied loads  
 $M_{d/nc}$  = non-composite dead load moment at the section  
 $M_{\text{max}}$  = maximum factored moment at section due to externally applied loads  
 $M_n$  = nominal moment strength of a section  
 $M_{\text{sec.}}$  = Secondary Moment  
 $\rho$  = ratio of non-prestressed tension reinforcements  
 $P$  = Prestressing Force  
 $\rho^* = A_s^*/bd$  ratio of prestressing steel  
 $P_{\text{avg}}$  = average stream pressure  
 $P_{\text{max}}$  = maximum stream flow pressure  
 $P_{\text{se}}$  = Effective prestressing force  
 $P_{\text{si}}$  = pound per square inch  
 $P_v$  = Vertical Prestressing Force at section considered  
 $R$  = annual average ambient relative humidity  
 $s$  = longitudinal spacing of the web reinforcement  
 $S$  = permissible speed  
 $S_b$  = noncomposite section modulus for the extreme bottom fiber  
 $S_s$  = Slab clear span for flanged sections  
 $S_t$  = noncomposite section modulus for the extreme top fiber  
 $SF$  = stream flow pressure  
 $SH$  = loss of prestress due to concrete shrinkage  
 $t$  = average thickness of the flange

$V_{avg}$  = average velocity of water

$V_c$  = nominal shear strength provided by concrete

$V_{ci}$  = nominal shear strength provided by concrete when diagonal cracking results from combined shear and moment

$V_{cw}$  = nominal shear strength provided by concrete when diagonal cracking results from excessive principal tensile stress in web

$V_d$  = shear force at section due to unfactored dead load

$V_i$  = factored shear force at section due to externally applied loads occurring

$V_p$  = vertical component of effective prestress force at section

$V_s$  = nominal shear strength provided by shear reinforcement

$V_u$  = the factored shear force at the section considered

$w$  = width of a section

$w_t$  = equivalent tendon load

$W$  = wind load on structure

$w_c$  = unit density (weight) of concrete

$WL$  = wind load on live load

$x$  = length of a prestressing tendon from the jacking end to point considered

$y_t$  = distance from centroidal axis of gross section to the extreme top fiber

$y_b$  = distance from centroidal axis of gross section to the extreme bottom fiber

$\dot{y}$  = factor for type of prestressing steel

$^{\circ}C$  = degree celsius

$\phi$  = Strength Reduction Factor

$\alpha$  = total angular change of prestressing steel profile in radians from jacking end to point  $x$

$\beta_1$  = factor for concrete strength

$\mu$  = friction curvature coefficient



## **ABBREVIATIONS**

- AASHTO = American Association of State Highway Officials
- ACI = American Concrete Institute
- AREMA = American Railway Engineering and Maintenance-of-Way Association
- ASTM = American Society for Testing and Materials
- LRFD = Load and Resistance Factor Design

## LIST OF TABLES

<b>Table 3.1</b> Temperature Ranges .....	26
<b>Table 3.2</b> Group Loading Combinations – Service Load Design .....	27
<b>Table 3.3</b> Group Loading Combinations – Load Factor Design .....	28
<b>Table 4.1</b> Spacing of Tendons .....	29
<b>Table 4.2</b> Values for K and $\mu$ .....	39
<b>Table 4.3</b> Recommended Minimum Thickness for Constant Depth Members .....	48
<b>Table 5.1</b> Standard Dimensions of Cable Ducts .....	63
<b>Table 6.1</b> Summary of the Cost Estimations of a Three Span Post-Tensioned Railway Bridge .....	70
<b>Table 6.2</b> SUMMARY OF QUANTITIES OF MATERIALS REQUIRED FOR BOX GIRDERS .....	71
<b>Table 6.3</b> SUMMARY OF QUANTITIES OF MATERIALS REQUIRED FOR T-GIRDERS .....	72
<b>TABLE A1:</b> DESIGN (FACTORED) SHEAR FORCES AND BENDING MOMENTS FOR BOX GIRDERS .....	82
<b>TABLE A2:</b> DESIGN (FACTORED) SHEAR FORCES AND BENDING MOMENTS FOR T-GIRDERS .....	84
<b>TABLE A3:</b> SUMMARY OF THE DESIGN OUTPUTS (BOX GIRDERS) .....	86
<b>TABLE A4:</b> SUMMARY OF THE DESIGN OUTPUTS (T-GIRDERS) .....	88
<b>TABLE A5:</b> LOCATION OF CENTROID DETERMINATION (BOX GIRDER) .....	93
<b>TABLE A6:</b> DETERMINATION OF MOMENT OF INERTIA ABOUT THE CENTROID OF THE SECTION (BOX GIRDER) .....	93
<b>TABLE A7:</b> OUTPUTS OF THE STRUCTURAL ANALYSIS FOR EACH SEGMENT (MAXIMUM VALUES FOR BOX GIRDER) .....	96
<b>TABLE A8:</b> CONSTRUCTION COST ESTIMATE FOR BOX GIRDER BRIDGE .....	120
<b>TABLE A9:</b> LOCATION OF CENTROID DETERMINATION (T-GIRDER) .....	126
<b>TABLE A10:</b> DETERMINATION OF MOMENT OF INERTIA ABOUT THE CENTROID OF THE SECTION (T-GIRDER) .....	127
<b>TABLE A11:</b> OUTPUTS OF THE STRUCTURAL ANALYSIS FOR EACH SEGMENT (MAXIMUM VALUES FOR T-GIRDER) .....	130
<b>TABLE A12:</b> CONSTRUCTION COST ESTIMATE FOR T-GIRDER BRIDGE .....	153

## LIST OF FIGURES

<b>Figure 2.1</b> Pre-tensioning .....	6
<b>Figure 2.2</b> Post-tensioning .....	7
<b>Figure 2.3</b> Reinforced concrete beam under loading .....	8
<b>Figure 2.4</b> Stresses in reinforced concrete beam under loading .....	8
<b>Figure 2.5</b> Comparisons of Reinforced and Prestressed Concrete Structures .....	9
<b>Figure 2.6</b> Different forms of the Prestressing Steel .....	11
<b>Figure 3.1</b> Truss-Arched Bridge .....	17
<b>Figure 3.2</b> Through-Truss Bridge .....	17
<b>Figure 3.3</b> Cast-in-place post-tensioned voided slab bridge .....	18
<b>Figure 3.4</b> Cooper E 80 (EM 360) Axle Load Diagram .....	21
<b>Figure 4.1</b> Three Span Post-Tensioned Beam .....	50
<b>Figure 4.2</b> Beam subjected to Prestressing Force only .....	51
<b>Figure 4.3</b> Reactions at Interior Supports due to Prestressing Force .....	51
<b>Figure 4.4</b> Secondary Moments Distribution .....	52
<b>Figure 4.5</b> Simply Supported Beam with Parabolic Tendon Profile .....	53
<b>Figure 4.6</b> Equivalent Tendon Loads Applied to Simply Supported Beam .....	54
<b>Figure 4.7</b> Typical Tendon Profile for a Three Span Continuous Structure .....	54
<b>Figure 4.8</b> Equivalent Tendon Loads Exerted on the Continuous Structure .....	55
<b>Figure 4.9</b> Post-Tensioning Anchorage Zones .....	56
<b>Figure 4.10</b> Typical Post-Tensioning Anchorage Devices .....	56
<b>Figure 4.11</b> Bursting Forces in the Anchorage Zone .....	59
<b>Figure 4.12</b> Strut-and-Tie Model of the Anchorage Zone .....	60
<b>Figure 7.1</b> AA-LRT Project Typical Elevated Section .....	75
<b>FIGURE A1:</b> THREE SPAN BOX GIRDER CONTINUOUS BRIDGE .....	90
<b>FIGURE A2:</b> TYPICAL BOX GIRDER BRIDGE CROSS SECTION .....	90
<b>FIGURE A3:</b> BOX GIRDER CROSS SECTION PROPERTIES .....	92
<b>FIGURE A4:</b> PRESTRESSING TENDON LAYOUT (BOX GIRDER) .....	98
<b>FIGURE A5:</b> TENDON PROFILE (BOX GIRDER) .....	106
<b>FIGURE A6:</b> EQUIVALENT LOAD FOR PARABOLIC TENDON PROFILE	

(BOX GIRDER) .....	106
<b>FIGURE A7:</b> TENDON LOADS ACTING ON THE STRUCTURE (BOX GIRDER) .....	107
<b>FIGURE A8:</b> REACTIONS INDUCED UNDER THE ACTION OF THE PRESTRESSING FORCE (BOX GIRDER) .....	108
<b>FIGURE A9:</b> BALANCED MOMENT DIAGRAM (BOX GIRDER) .....	108
<b>FIGURE A10:</b> PRIMARY MOMENT DIAGRAM (BOX GIRDER) .....	109
<b>FIGURE A11:</b> SECONDARY MOMENT DIAGRAM (BOX GIRDER) .....	110
<b>FIGURE A12:</b> BEARING PLATES ARRANGEMENT (BOX GIRDER) .....	117
<b>FIGURE A13:</b> STRUT-AND-TIE MODEL OF THE ANCHORAGE ZONE (BOX GIRDER) ....	118
<b>FIGURE A14:</b> REINFORCEMENT PATTERN FOR BURSTING FORCES (BOX GIRDER) ....	119
<b>FIGURE A15:</b> BOX GIRDER REINFORCEMENT DETAIL AT SPAN .....	122
<b>FIGURE A16:</b> BOX GIRDER REINFORCEMENT DETAIL AT SUPPORT .....	122
<b>FIGURE A17:</b> THREE SPAN T-GIRDER CONTINUOUS BRIDGE .....	124
<b>FIGURE A18:</b> TYPICAL T-GIRDER BRIDGE CROSS SECTION .....	124
<b>FIGURE A19:</b> T-GIRDER CROSS SECTION PROPERTIES .....	126
<b>FIGURE A20:</b> PRESTRESSING TENDON LAYOUT (T-GIRDER) .....	132
<b>FIGURE A21:</b> TENDON PROFILE (T-GIRDER) .....	140
<b>FIGURE A22:</b> EQUIVALENT LOAD FOR PARABOLIC TENDON PROFILE (T-GIRDER) ....	140
<b>FIGURE A23:</b> TENDON LOADS ACTING ON THE STRUCTURE (T-GIRDER) .....	141
<b>FIGURE A24:</b> REACTIONS INDUCED UNDER THE ACTION OF THE PRESTRESSING FORCE (T-GIRDER) .....	141
<b>FIGURE A25:</b> BALANCED MOMENT DIAGRAM (T-GIRDER) .....	142
<b>FIGURE A26:</b> PRIMARY MOMENT DIAGRAM (T-GIRDER) .....	143
<b>FIGURE A27:</b> SECONDARY MOMENT DIAGRAM (T-GIRDER) .....	144
<b>FIGURE A28:</b> BEARING PLATES ARRANGEMENT (T-GIRDER) .....	151
<b>FIGURE A29:</b> STRUT-AND -TIE MODEL OF THE ANCHORAGE ZONE (T-GIRDER) .....	152
<b>FIGURE A30:</b> REINFORCEMENT PATTERN FOR BURSTING FORCES (T-GIRDER) .....	153
<b>FIGURE A31:</b> T-GIRDER REINFORCEMENT DETAIL AT SPAN .....	155
<b>FIGURE A32:</b> T-GIRDER REINFORCEMENT DETAIL AT SUPPORT .....	155

## TABLE OF CONTENTS

<b>ACKNOWLEDGMENTS</b> .....	ii
<b>ABSTRACT</b> .....	iii
<b>LIST OF SYMBOLS</b> .....	iv
<b>ABBREVIATIONS</b> .....	viii
<b>LIST OF TABLES</b> .....	ix
<b>LIST OF FIGURES</b> .....	x
<b>1. INTRODUCTION</b>	
1.1 Background .....	1
1.2 Statement of the Problem .....	2
1.3 Research Objectives .....	3
1.4 Application of the Study and Limitations .....	3
1.5 Organization .....	3
<b>2. LITERATURE REVIEW</b>	
2.1 Prestressed Concrete .....	5
2.2 Methods of Prestressing	
2.2.1 Pre-tensioning .....	5
2.2.2 Post-tensioning .....	6
2.3 Comparison of Reinforced and Prestressed Concrete Structures .....	7
2.4 Materials for Prestressing	
2.4.1 Concrete .....	10
2.4.2 Prestressing Steel .....	10
2.4.3 Anchorages .....	12
2.4.4 Cement Grout .....	12
2.4.5 Stressing Jacks .....	12
2.5 Previous Studies on Continuous Post-Tensioned Concrete Bridges .....	12

### **3. BASICS OF BRIDGE DESIGN**

3.1 INTRODUCTION .....	15
3.2 BRIDGE CLASSIFICATION .....	16
3.3 RAILWAY BRIDGE LOADING	
3.3.1 General .....	18
3.3.2 Dead Load .....	19
3.3.3 Live Load .....	19
3.3.4 Impact Load .....	21
3.3.5 Centrifugal Force .....	21
3.3.6 Earth Pressure .....	22
3.3.7 Buoyancy .....	22
3.3.8 Wind Load on Structure .....	22
3.3.9 Wind Load on Live Load .....	23
3.3.10 Longitudinal Force .....	23
3.3.11 Longitudinal Force Due to Friction or Shear Resistance .....	24
3.3.12 Earthquake .....	24
3.3.13 Stream Flow Pressure .....	24
3.3.14 Ice Pressure .....	26
3.3.15 Other Forces .....	26
3.4 LOADING COMBINATIONS	
3.4.1 General .....	27
3.4.2 Service Load Design .....	27
3.4.3 Load Factor Design .....	28

### **4. DESIGN OF PRESTRESSED CONCRETE RAILWAY BRIDGES**

4.1 Details of Prestressing Tendons and Ducts .....	29
4.1.1 Spacing of Tendons and Ducts .....	29
4.1.2 Minimum Concrete Cover .....	30
4.1.3 Post-Tensioning Ducts .....	30
4.2 General Analysis .....	30

4.3 Span Length .....	31
4.4 Effective Flange Width .....	31
4.5 Flange and Web Thickness-BOX Girders .....	32
4.6 Deflections .....	32
4.6.1 Computation of Deflections .....	33
4.7 General Design	
4.7.1 Design Theory and General Considerations .....	33
4.7.2 Basic Assumptions .....	33
4.8 Load Factors .....	33
4.8.1 Required Strength .....	33
4.9 Allowable Stresses	
4.9.1 Prestressing Tendons .....	34
4.9.2 Concrete .....	35
4.9.3 Cracking Stress .....	35
4.9.4 Anchorage Bearing Stress .....	36
4.10 Loss of Prestress .....	36
4.10.1 Prestress Losses .....	36
4.11 Flexural Strength	
4.11.1 Introduction .....	39
4.11.2 Rectangular Sections .....	40
4.11.3 Flanged Sections .....	40
4.11.4 Steel Stress .....	41
4.12 Ductility Limits .....	42
4.12.1 Maximum Prestressing Steel .....	42
4.12.2 Minimum Reinforcement .....	42
4.13 Non-Prestressed Reinforcement .....	43
4.14 Shear .....	43
4.14.1 General .....	43
4.14.2 Shear Strength Provided By Concrete .....	44
4.14.3 Shear Strength Provided by Web Reinforcement .....	46

4.15 T-Girder Construction .....	47
4.16 Box Girder Construction .....	47
4.17 Structural Depth .....	49
4.18 Web Thickness .....	49
4.19 Number of Cells .....	49
4.20 Spacing of Girders .....	50
4.21 Secondary (Hyperstatic) Moments .....	50
4.22 Post-Tensioned Anchorages Zones .....	53
4.23 Bearing Strength .....	56
4.24 Bursting Forces in Anchorage Zones .....	56

## **5. DESIGN OF PRESTRESSED CONCRETE RAILWAY BRIDGES**

5.1 Background .....	61
5.2 Design Parameters .....	62
5.3 Materials properties .....	62
5.4 Design Assumptions .....	64
5.5 Design Steps .....	65
5.6 Design Algorithm .....	67

## **6. FINDINGS OF THE STUDY .....**

## **7. RESULTS AND CONCLUSIONS**

7.1 CONCLUSIONS	
7.1.1 Economical Span Combination .....	74
7.1.2 Economical Section .....	74
7.1.3 Further Research .....	75
7.2 RECOMMENDATIONS .....	75



**APPENDICES**

A. Materials Specifications ..... 78

B. Summary of Design Actions for Box Girders ..... 81

C. Summary of Design Actions for T-Girders ..... 83

D. Summary of Cross Section Properties for Box Girders ..... 85

E. Summary of Cross Section Properties for T-Girders ..... 87

F. Complete Design of a Three Span Continuous Box Girder  
    Post-Tensioned Prestressed Railway Bridge ..... 89

G. Reinforcement Detail for box Girder ..... 121

H. Complete Design of a Three Span Continuous T-Girder  
    Post-Tensioned Prestressed Railway Bridge ..... 123

I. Reinforcement Detail for box Girder ..... 154

**REFERENCES** ..... 156

# 1. INTRODUCTION

## 1.1 Background

Bridge is a structure providing passage over an obstacle. The obstacle may be a river, valley, road or railway. The passage may be for highway or railway traffic, pedestrian, canal or pipeline. Thus, Bridges are essential elements of highways and railways in the transportation system.

Designing a bridge structure or an elevated guide way is a very complex task. Its fundamental objectives are safety, serviceability, economy and elegance. A number of decisions need to be made in order to undertake the design of a specific bridge. The type of a bridge to be selected is one of the most important parameters of the design phase since it greatly affects the construction materials, labour requirement, construction methodology, machineries and equipment needed for the execution of the structure. All the factors mentioned here will finally affect the investment required for the construction of a specific type of bridge. Consequently, the designer must know the most economical type of bridge for a specific section or span before undertaking the complete design of the structure. Span is the distance between the centers of two exterior supports of a bridge. The type of bridge that will be selected should also fulfill the fundamental design objectives safety, serviceability and aesthetics in addition to cost-effectiveness.

Thus, a number of decisions need to be made in order to undertake the design of a bridge that will fulfill all the fundamental design objectives. Probably, one of the decisions that should be made at the early stage of the design phase is determination of the span of the bridge. For shorter distances, a simply supported bridge with only two supports at the end can be sufficient to provide passage over an obstacle, and thus it is called a simply supported bridge. For longer distances, intermediate supports will be required for safety and serviceability requirements forming a continuous span bridge.

Use of continuous span bridges will have the following advantages as compared to simple span bridges:

- I. A reduction of material in the superstructure, or longer spans for the same material and thus less number of piers,
- II. Less deflection and vibration,
- III. Requires less number of anchorages of tendons,
- IV. Fewer expansion devices are needed,
- V. Fewer sets of bearing are used, thus there is the possibility of narrower piers,
- VI. More pleasing appearance.

However; there are also disadvantages which are associated to continuous span bridges. These include:

- I. The analysis and design procedures are a little bit complex as compared to simple span bridges,
- II. Settlement of the supports may induce secondary stresses if the foundations are not rigid,
- III. Frictional losses might increase due to changes of curvature of the tendons at the supports,
- IV. Secondary stresses develop due to the continuity of the tendons and time dependent effects like creep, shrinkage, and variations in temperature.

## **1.2 Statement of the Problem**

Railway bridges of the Addis Ababa Light Rail Transit (AA-LRT) Project, whose construction is currently underway, are a series of simply supported prestressed concrete segments, with a dominant span of 19.90m each. For a bridge with a total span of 100.00m, the section requires five segments of 19.90m length girders and six supports. This study will, therefore, assess the use of continuous span post-tensioned concrete bridges as an alternative option for railway lines thereby identifying the economical span combination

(or span arrangement) and economical section for a three span 100.00m long post-tensioned concrete railway bridge.

### **1.3 Research Objectives**

This thesis shall assess the use of continuous span post-tensioned concrete railway bridges as an alternative option to a series of simply supported segments for longer elevated railway sections.

The objectives of this study are:

- I. To determine the economical span combination of a three span continuous post-tensioned concrete railway bridge superstructure, with a total length of 100.00m, using Box and T-Girder sections.
- II. To determine the economical section of a three span 100.00m long continuous post-tensioned concrete railway bridge superstructure: Box or T-Girder.

### **1.4 Application of the Study and Limitations**

The scope of the study has been limited to the analysis and design of a three Span Post-Tensioned Concrete Railway Bridge Superstructures, with a total length of 100.00m, in order to identify the span composition (or span arrangement) of the specific length of elevated railway section, and thereby indicating the economical section to be used for the particular span being considered in this study.

### **1.5 Organization**

Chapter 1 has presented the need for construction of a bridge thereby introducing statement of the problem, research objectives and application of the study.

In Chapter 2, Prestressed Concrete is defined, also addressing the types and methods of application of prestressed concrete. Properties of materials to be used for Prestressed Concrete and previous studies on the subject are also discussed.

Chapter 3 discusses the basic requirements of the bridge design process, bridge classifications and different types of loadings and loading combinations to be considered for railway bridges design.

In Chapter 4 outlines different bridge design requirements and criteria which are extracted from different standard documents, guidelines and manuals. Different design parameters to be used shall be defined for the purposes of this thesis undertaking.

Chapter 5 presents all the procedures need to be adopted for the design of the bridge superstructure in such a manner that the objectives primarily set at the beginning of this study are achieved.

Chapter 6 reports the summary of the thesis findings and results against the objectives set forth.

Finally, Chapter 7 presents conclusions and recommendations of the study in line with the thesis objectives and findings.

## 2. LITERATURE REVIEW

### 2.1 Prestressed Concrete

American Concrete Institute (ACI) Committee has defined Prestressed Concrete as:

"Concrete in which there has been introduced internal stresses of such magnitude and distribution that the stresses resulting from given external loadings are counteracted to a desired degree. In reinforced concrete members the prestress is commonly introduced by tensioning the steel reinforcement."

The concrete can be either fully prestressed, which ensures that the longitudinal stresses are always in compression, or partially prestressed which allows some tension to occur under certain loading conditions.

### 2.2 Methods of Prestressing

There are two methods of prestressing:

- **Pre-tensioning:** Apply prestress to steel strands before casting concrete;
- **Post-tensioning:** Apply prestress to steel tendons after casting concrete.

#### 2.2.1 Pre-tensioning

In pretensioning, the tendons are first stressed to a given level and then the concrete is cast around them. The tendons may be composed of wires, bars or strands. The most common system of pretensioning is the long line system, by which a number of units are produced at once. First the tendons are stretched between anchorage blocks at opposite ends of the long stretching bed. Next the spacers or separators are placed at the desired member intervals, and then the concrete is placed within these intervals. When the concrete has attained a sufficient strength, the steel is released and its stress is transferred to the concrete via bond. The protruding ends of the tendons are then cut away to produce the finished concrete member. This is the most common form for precast sections.

- Stage 1: the wires or strands are stressed;
- Stage 2: the concrete is cast around the stressed wires/strands;
- Stage 3: the prestressing is transferred from the external anchorages to the concrete, once it has sufficient strength.

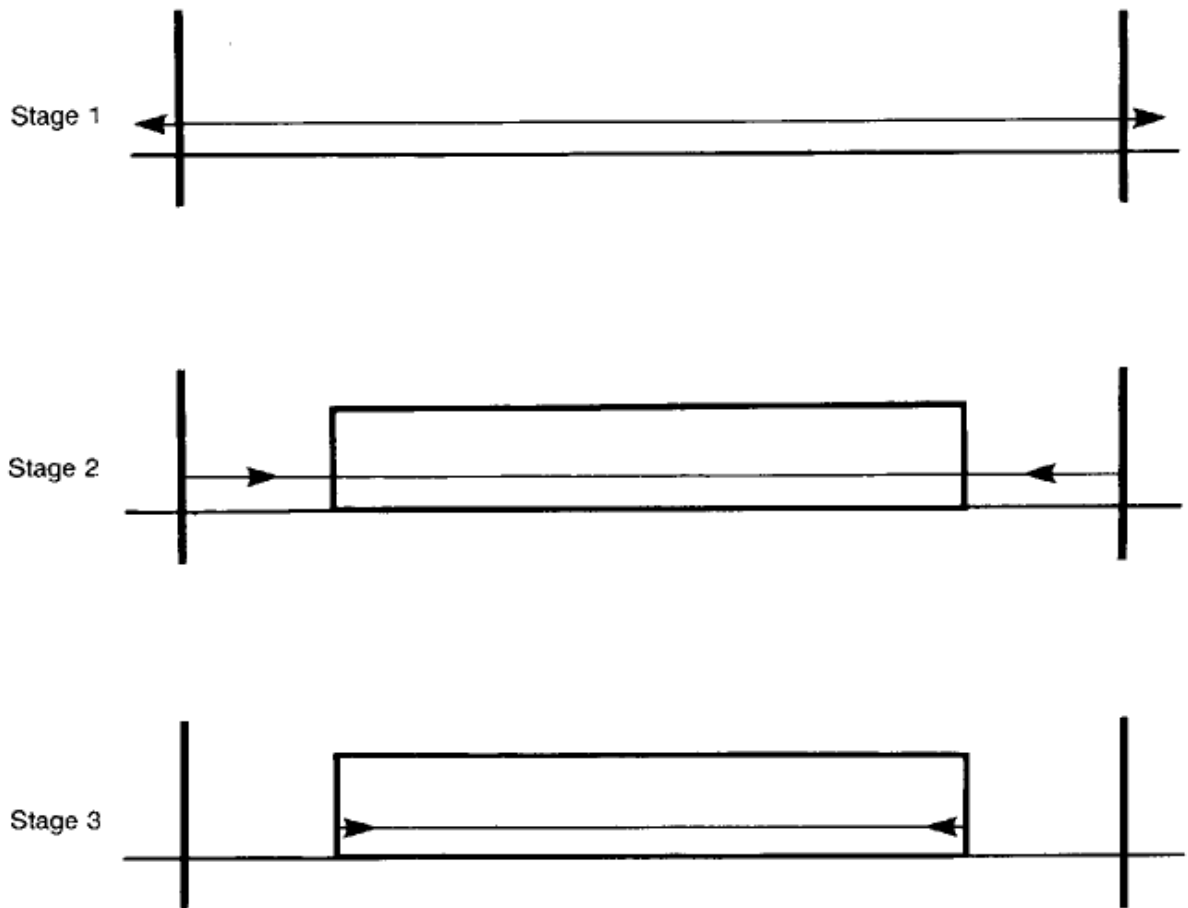

Figure 2.1 Pre-tensioning

### 2.2.2 Post-tensioning

In post-tensioning, the concrete member is first cast with one or more post-tensioning ducts or tubes for future insertion of tendons. Once the concrete is sufficiently strong, the tendons are stressed by jacking against the concrete. When the desired prestress level is reached, the tendons are locked under stress by means of end anchorages or clamps.

Subsequently, the duct is filled with cement grout to protect the steel from corrosion and give the added safeguard of bond. This not only helps to protect the tendons, but also improves the ultimate strength capacity of the member. Nearly all in situ prestressing is carried out using this method.

- Stage 1: the strands or tendons are fed through the ducts;
- Stage 2: the strands are tensioned;
- Stage 3: finally anchored to the concrete.

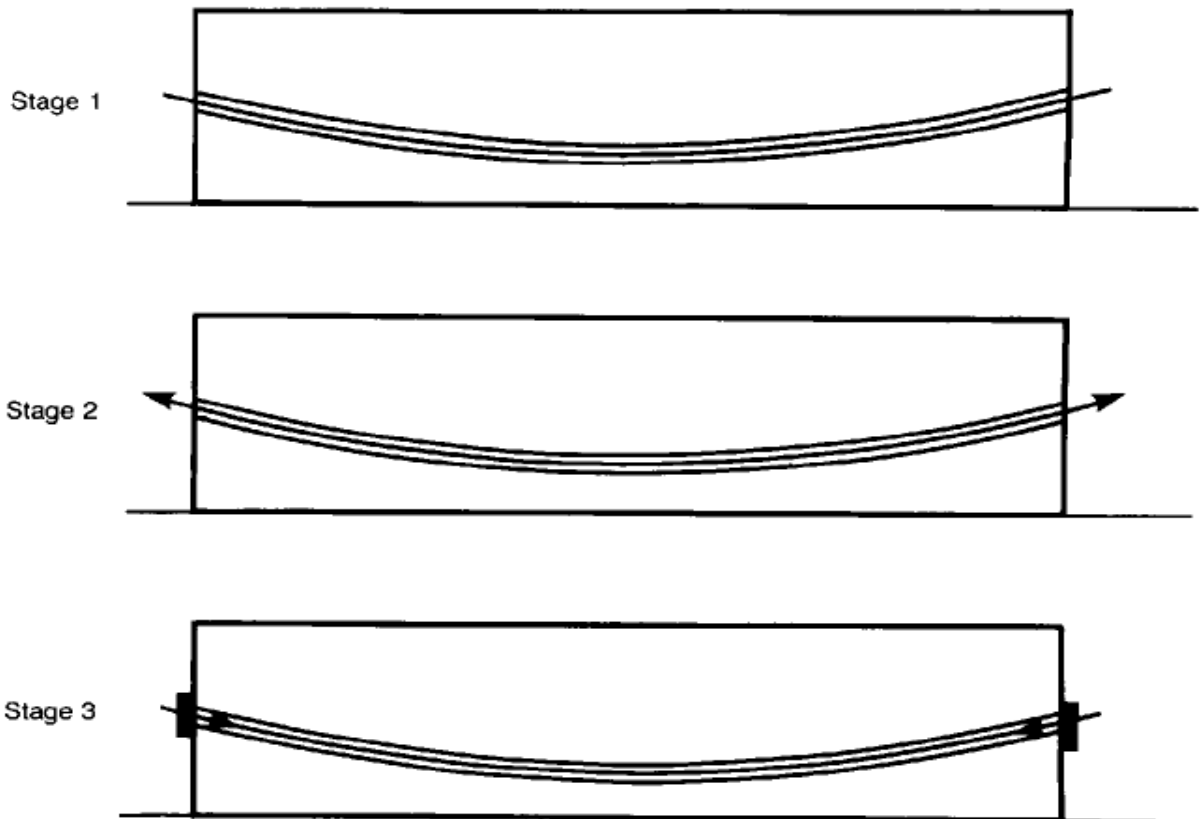

Figure 2.2 Post-tensioning

### 2.3 Comparisons of Reinforced and Prestressed Concrete Structures

Concrete is very strong in compression but weak in tension. In an ordinary concrete beam the tensile stresses at the bottom are carried by standard steel reinforcement (Caprani, 2006/7).



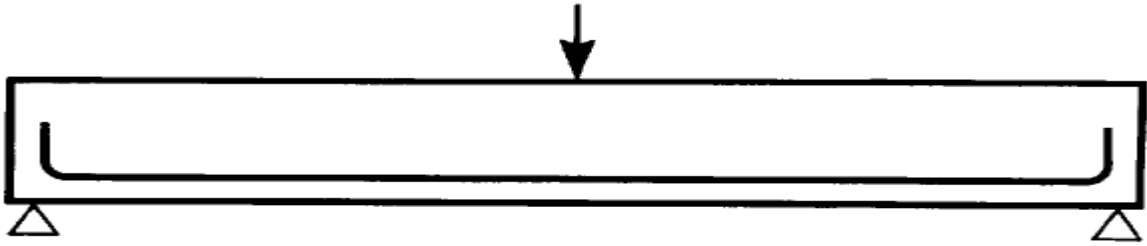

Figure 2.3 Reinforced concrete beam under loading

But there are still cracks which are due to both bending and shear:

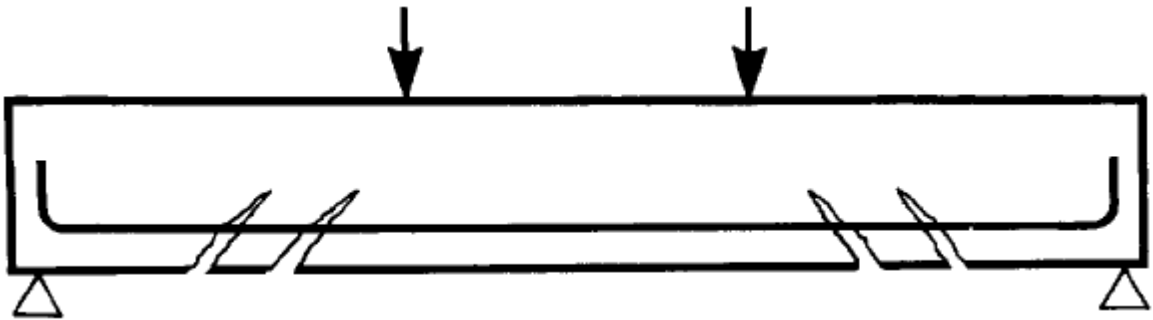

Figure 2.4 Stresses in reinforced concrete beam under loading

In prestressed concrete, because the prestressing keeps the concrete in compression, no cracking occurs. This is often preferable where durability is a concern.

US Department of Transportation, Federal Highway Administration, Post Tensioning Tendon Installation and Grouting Manual (May 2013) compares the reinforced and prestressed concrete structures using diagrams as shown below:

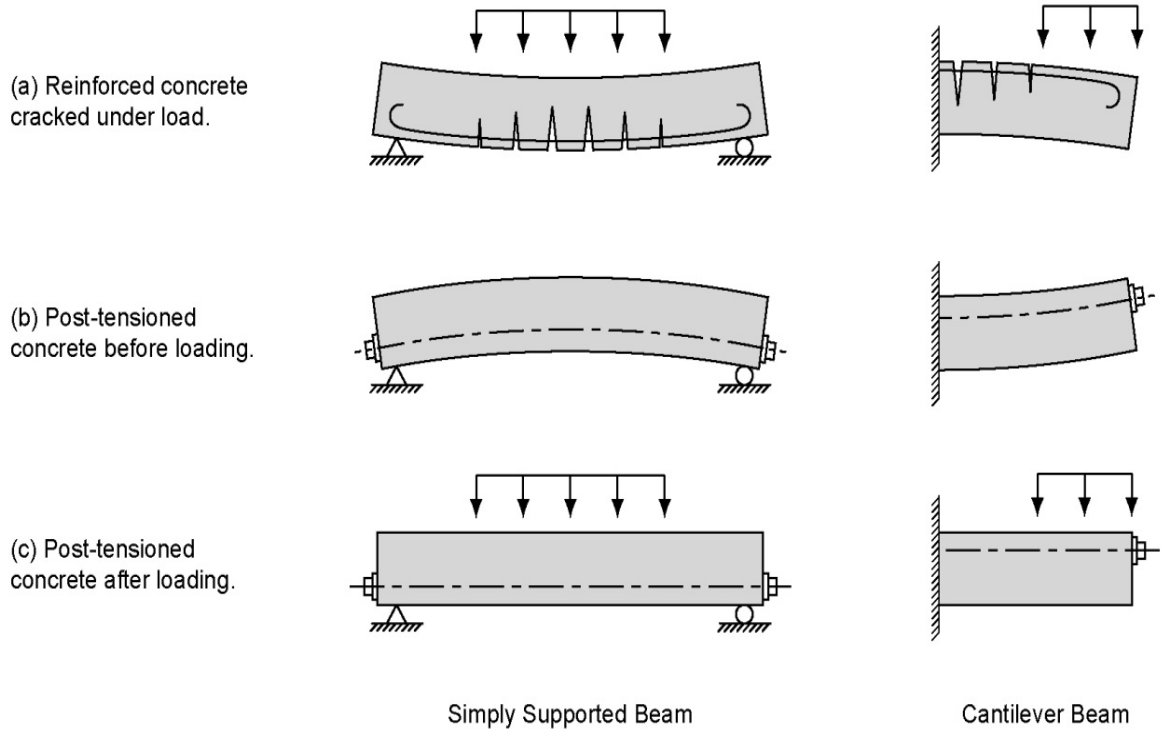

Figure 2.5 Comparisons of Reinforced and Prestressed Concrete Structures

The function of prestressing is to place the concrete structure under compression in those regions where load causes tensile stress. Tension caused by applied loads will first have to cancel the compression induced by the prestressing before it can crack the concrete. Figure 2.5 (a) shows a plainly reinforced concrete simple span beam and fixed cantilever beam cracked under applied load. Figure 2.5 (b) shows the same unloaded beams with prestressing forces applied by stressing post-tensioning tendons. By placing the prestressing low in the simple-span beam and high in the cantilever beam, compression is induced in the tension zones; creating upward camber. Figure 2.5 (c) shows the two prestressed beams under the action of post-tensioning and applied loads. The loads cause both the simple-span beam and cantilever beam to deflect down, creating tensile stresses in the bottom of the simple-span beam and top of the cantilever beam. The designer balances the effects of load and prestressing in such a way that tension from the loading is compensated by compression induced by the prestressing. Tension is eliminated under

the combination of the two and tension cracks are prevented. As a result, durability is increased and more efficient, cost effective construction is realized.

## **2.4 Materials for Prestressing**

Materials which are commonly used for prestressing are discussed in detail below (ICE Manual of Bridge Engineering, 2008, Institute of Civil Engineers).

### **2.4.1 Concrete**

The required strength of the concrete is determined by the compressive stresses generated in the concrete by the prestress and applied forces. A minimum strength of 45MPa is typical for prestressed concrete; however, it is becoming more common to use higher strengths up to 70MPa, while even higher values have been achieved for some projects. The rate of gain of strength of the concrete is important as this governs the time at which the prestress can be applied. At the time of transfer of the prestress force to the concrete it is normally required that the concrete strength be at least a minimum of 30MPa, although this can vary depending on the tendon and anchor arrangement and the magnitude of load applied to the tendon. To minimize creep and shrinkage losses in the prestressing, the cement content and water to cement ratio of the concrete should be kept to a minimum, compatible with the high concrete strengths required.

### **2.4.2 Prestressing Steel**

High-tensile steel is used as wire, strand or bars, with nominal tensile strengths varying between 1570MPa and 1860MPa for wire or strand, and between 1000MPa and 1080MPa for bars.

- **Wires**

Individual wires are sometimes used in pre-tensioned beams but have become less common in favor of strand, which has better bonding characteristics. Wire diameters are typically between 5mm and 7mm with a minimum tensile strength of 1570MPa and can carry forces up to 45KN.

- **Strands and Tendons**

A seven-wire strand with a tensile strength of 1860MPa and either 13mm or 15mm diameter is a very common form of prestressing and can be used either singularly for pretensioning or in bundles to form multi-strand tendons for post-tensioning. The most common post-tensioned tendon sizes utilize 7, 12, 19 or 27 strands to suit the standard anchor blocks available, but tendons can incorporate up to 55 strands for larger tendons. Stressing to 75% ultimate tensile strength gives a typical jacking force of 140kN or 199kN for the 13mm or 15mm diameter strand, respectively, while the larger multi-strand tendons can carry forces up to 10,000kN. During stressing, jacks are placed over the tendon, gripping each strand and pulling it until the required force is generated. Wedges are then placed around the strand and seated into the anchor block so that on release of the jack the wedges grip the strand and transfer the force on to the anchor and into the concrete.

- **Bars**

Individual bars can vary in diameter from 15mm up to 75mm and are used in post-tensioned construction with jacking forces ranging from 135kN to 30,00kN. The bars are placed into ducts which have been cast into the concrete between two anchor blocks on the concrete surface. The bars are pulled from one end by a stressing jack and held in place by a nut assembly which transfers the load from the bar to the anchor block and then into the concrete.

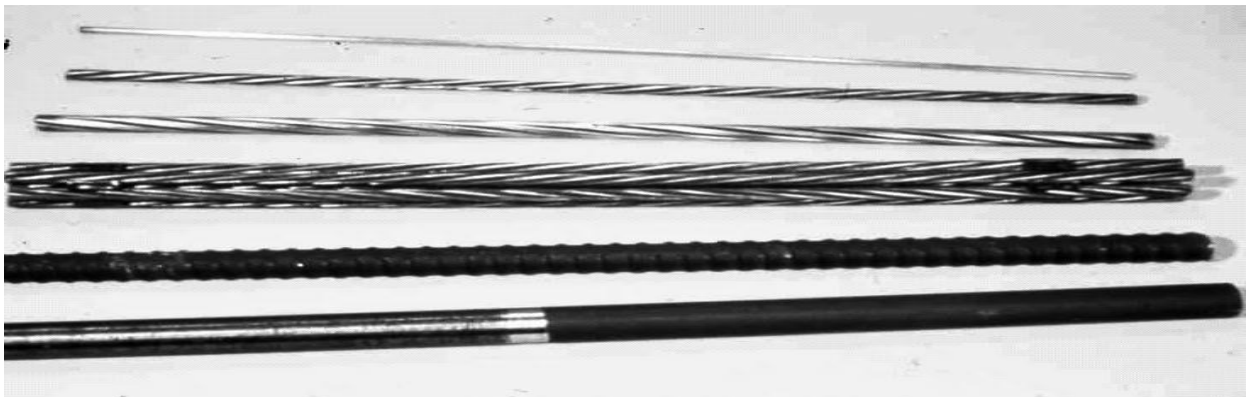

Figure 2.6 Different forms of the Prestressing Steel (Caprani, 2006/7)

### **2.4.3 Anchorages**

At each end of the tendon the forces are transferred into the concrete by an anchorage system. For pre-tensioned tendons the anchorage is by bond of the bare strand cast into the concrete, while for post-tensioned tendons the anchorage can be either by anchorage blocks or by bond for some types of cast-in dead-end anchors.

### **2.4.4 Cement Grout**

Cement grout is used to fill the void around post-tensioned tendons and their ducts; a water-to-cement ratio of between 0.35 and 0.40 is typically used, with admixtures often added to improve flow and to reduce shrinkage and the water-to-cement ratio.

### **2.4.5 Stressing Jacks**

Jacks are used for stressing the steel. For single strands, smaller tendons or smaller bars, the jacks, weighing up to 250kg, can usually be easily handled and maneuvered into position with readily available lifting equipment, while for the larger tendons special lifting frames or cranes are required to move the jacks which can weigh up to 2,000kg.

## **2.5 Previous Studies on Continuous Post-Tensioned Concrete Bridges**

Arrangement of the spans of a continuous bridge affects the total construction cost of the superstructure. For each interior-to-exterior span ratio, the construction cost is different since the design actions vary with positions of interior supports. Thus, identifying the optimum (economical) span combination of a continuous bridge will be helpful at the design stage provided that other bridge design requirements are satisfied.

A project to electrify a portion of the main trunk rail route in the **North Island of New Zealand** has been completed. In conjunction with this project 7.50Km of track between **Ohakune** and **Horopito (Central North Island)** have been realigned to remove the existing

tight curves and steep gradients thus improving the traffic speed and load carrying capacity. This has required the replacement of the existing **Hapuawhenua** Viaduct with a new crossing traversing the stream. After the decision to provide a bridge was made, preliminary design and cost estimations were carried out for different alternatives;

- Universal beam sections spanning 10m, welded plate girders spanning 20m, and 40m span galvanized steel trusses,
- Continuous reinforced concrete spanning 20m,
- Continuous post-tensioned concrete with 20, 40 and 60m spans cast-in-situ or incrementally launched,
- Simply supported precast concrete units with a composite concrete deck.

From the alternatives described above, decision was made to proceed with continuous post-tensioned concrete railway bridge deck using uniform superstructure depth. The total span of the bridge was 414m, nineteen spans of 20m and two 17m end spans, with interior-to-exterior span ratio of 1.18.

A. Mohammed, A. Abul, A. Husein (2012) have conducted a research to find out the optimum span combination of a two-span and three-span post-tensioned concrete bridge girders of non-uniform depth, using AASHTO H20 Live Loading. They have used interior-to-exterior span ratio, the depth profile of the cross-section, the prestressing tendon profile, and the prestressing force as the design variables. Results show that for a symmetrical three-span continuous bridge girder, the optimum design is obtained at an optimum ration of interior-to-exterior span of 1.35 to 1.45.

Booker Associates Inc. and Kansas Department of Transportation have performed a study in 1998 to design and prepare standards for post-tensioned concrete haunched (non-uniform depth) slab bridge superstructure, using AASHTO HS-20 AND HS-23 Live Loading. The slab thickness in the longitudinal direction varies with the parabolic profile of the design moment resulting in a highly efficient and optimum design. The study has recommended an average interior-to-exterior span ration of 1.31 for an optimum design,

which yields balanced design moments for a three-span post-tensioned concrete slab bridges.

NDOT STRUCTURES MANUAL (2008), Chapter 15: Steel Structures has indicated the end spans to be approximately 80% of the interior spans (i.e. interior-to-exterior span ratio of 1.25) for continuous highway steel bridges. This arrangement results in the largest possible negative moments at the piers and smaller resulting positive moments and girder deflections.

U.S. Department of Transportation Federal Highway Administration, Steel Bridge Design Hand Book (2012) specifies the ratio of interior-to-exterior span to be 1.25 for a three-span continuous straight composite steel I-girder highway bridge for optimum design, using HL-93 Live Loading.

Portland Cement Association (Continuous Concrete Bridges, 2<sup>nd</sup> Edition) recommends the ratio of interior-to-exterior span between 1.30 and 1.40 for continuous concrete girder highway bridges to obtain optimum design.

### 3. BASICS OF BRIDGE DESIGN

#### 3.1 INTRODUCTION

Every bridge project requires collection of extensive data which are useful to identify the possible alternatives of site, bridge type, etc. This can be achieved through detailed investigation at the feasibility stage of the project implementation. The aim of the investigation is to select a suitable site from possible alternatives at which a bridge can be built economically, at the same time satisfying the demands of safety, serviceability, and aesthetics.

In this first stage of the design phase, the engineer identifies a preferred location for the bridge and decides on the type, size and capacity of the structure. Generally, the following factors are considered in order to select the type of the bridge:

- Safety,
- Aesthetics,
- Functional requirements,
- Geometric conditions of the site,
- Subsurface conditions of the site,
- Economics and ease of construction,
- Construction and erection methods, etc.

Once the type of the bridge is determined, the next step shall be detail design of the structure using the data obtained from site investigations, at the planning stage, which include:

- Traffic Studies,
- Hydrological Studies,
- Geotechnical Studies,
- Environmental Considerations,
- Economic Analysis, etc.



### **3.2 BRIDGE CLASSIFICATION**

A number of different methods are used to classify bridges. Bridges can be classified according to

#### **I. Materials**

- Concrete,
- Steel,
- Wood,

#### **II. Usage**

- Pedestrian,
- Highway,
- Railroad,

#### **III. Span**

- Short,
- Medium,
- Long,

#### **IV. Structural Form**

- Slab,
- Girder,
- Truss,
- Arch,
- Suspension,
- Cable-stayed.

The classification of bridge types can also be made according to the location of the main structural elements relative to the surface on which the user travels, i.e. whether the main structure is below, above, or coincides with the deck line.

#### **3.2.1 Main Structure below the Deck Line**

- Masonry arch,

- Concrete arch,
- Steel truss-arch,
- Steel deck truss,
- Rigid frame, and
- Inclined leg frame bridges.



Figure 3.1 Truss-Arched Bridge, New River Gorge Bridge.(Courtesy of Michelle Rambo-Roddenberry, 1996.)

### 3.2.2 Main Structure above the Deck Line

- Suspension,
- Cable-stayed, and
- Through-truss bridges.



Figure 3.2 Through-Truss Bridge, Greater New Orleans Through-Truss Bridge (Courtesy of Amy Kohls, 1996.)

### 3.2.3 Main Structure Coincides with the Deck Line

- Slab (solid and voided),
- T-beam (cast-in-place),
- I-beam (precast or prestressed),
- Wide-flange beam (composite and non-composite),
- Concrete box (cast-in-place and segmental, prestressed),
- Steel box (orthotropic deck), and
- Steel plate girder (straight and haunched) bridges.

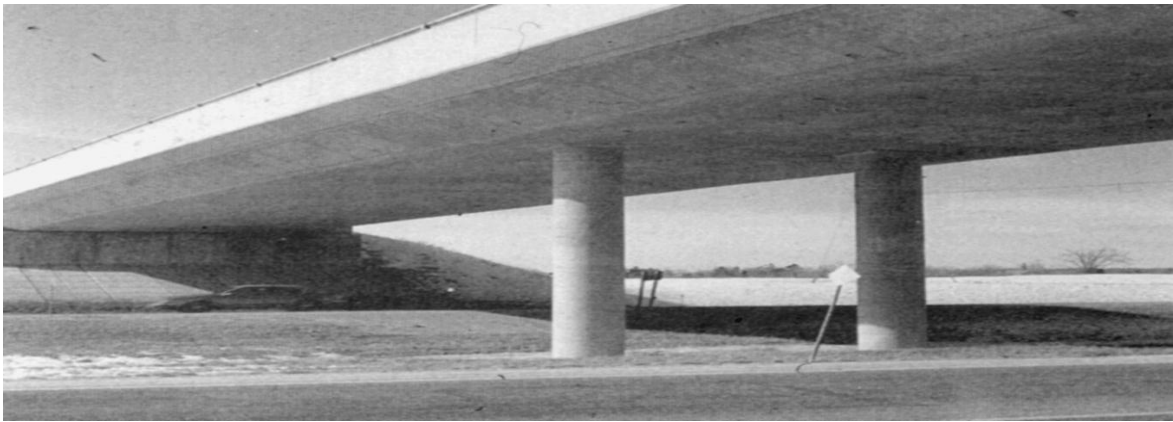

Figure 3.3 Cast-in-place post-tensioned voided slab bridge (Dorton, 1991). (From Bridge Aesthetics Around the World, copyright © 1991 by the Transportation Research Board, National Research Council, Washington, DC.)

## 3.3 RAILWAY BRIDGE LOADING

### 3.3.1 General

The following loads and forces shall be considered in the design of railway concrete structures supporting tracks (American Railway Engineering and Maintenance-of-Way Association Manual, 2010):

- D = Dead Load
- LL = Live Load
- I = Impact
- CF = Centrifugal Force

- E = Earth Pressure
- B = Buoyancy
- W = Wind Load on Structure
- WL = Wind Load on Live Load
- LF = Longitudinal Force from Live Load
- F = Longitudinal Force due to Friction or Shear Resistance at Expansion Bearings
- EQ = Earthquake (Seismic)
- SF = Stream Flow Pressure
- ICE = Ice Pressure
- OF = Other Forces (Rib Shortening, Shrinkage Temperature, and/oe Settlement of Supports)

### **3.3.2 Dead Load**

1. The dead load shall consist of the estimated weight of the structural member, plus that of the track, ballast, fill, and other portions of the structure supported thereby.
2. The unit weight of materials comprising the dead load, except in special cases involving unusual conditions or materials, shall be assumed as follows:
  - Track rails, inside guardrails and fastenings – 200 lb per linear foot of track (3kN/m).
  - Ballast, including track ties – 120 lb per cubic foot (1900 kg/m<sup>3</sup>).
  - Reinforced concrete – 150 lb per cubic foot (2400 kg/m<sup>3</sup>).
  - Earth filling materials – 120 lb per cubic foot (1900 kg/m<sup>3</sup>).
  - Waterproofing and protective covering – estimated weight.

### **3.3.3 Live Load**

1. The recommended live load for each track of main line structure is Cooper E 80 (EM 360) loading with axle loads and axle spacing as shown in Figure 3.4. On branch lines and in other locations where the loading is limited to the use of light equipment, or

cars only, the live load may be reduced, as directed by the engineer. For structures wherein the material in the primary load-carrying members is not concrete, the E loading used for the concrete design shall be that used for the primary members.

2. The axle loads on structures may be assumed as uniformly distributed longitudinally over a length of 3 feet (900 mm), plus the depth of ballast under the tie, plus twice the effective depth of slab, limited, however, by the axle spacing.
3. Live load from a single track acting on the top surface of a structure with ballasted deck or under fills shall be assumed to have uniform lateral distribution over a width equal to the length of track tie plus the depth of ballast and fill below the bottom of tie, unless limited by the extent of the structure.
4. The lateral distribution of live load from multiple tracks shall be as specified for single tracks and further limited so as not to exceed the distance between centers of adjacent tracks.
5. The lateral distribution of the live load for structures under deep fills carrying multiple tracks shall be assumed as uniform between centers of outside tracks, and the loads beyond these points shall be distributed as specified for single track. Widely separated tracks shall not be included in the multiple track group.
6. In calculating the maximum live loads on a structural member due to simultaneous loading on two or more tracks, the following proportions of the specified live load shall be used:
  - For two tracks – full live load,
  - For three tracks – full live load on two tracks and one-half on the other track,
  - For four tracks – full live load on two tracks, one-half on one track, and one-fourth on the remaining track.
7. The tracks selected for full live load in accordance with the listed limitations shall be those tracks which will produce the most critical design condition on the member under consideration.

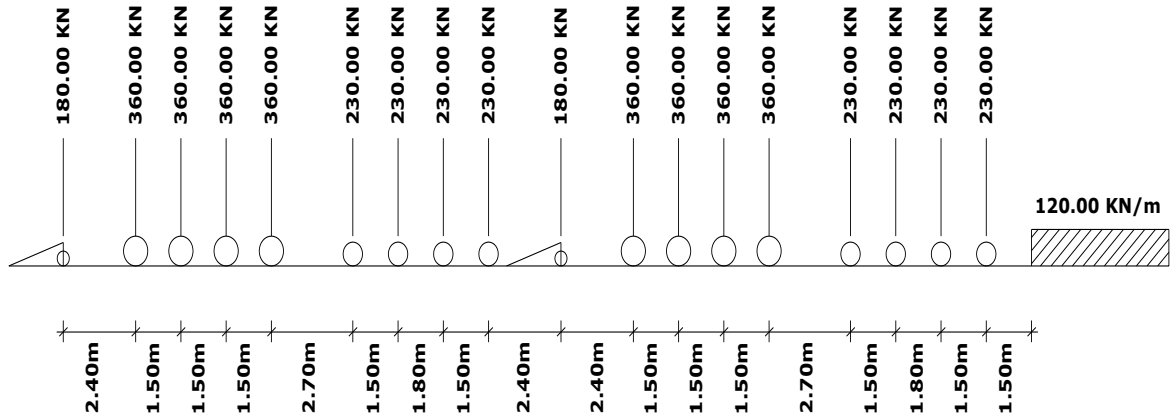

Figure 3.4 Cooper E 80 (EM 360) Axle Load Diagram

### 3.3.4 Impact Load

1. Impact forces, applied at the top of rail, shall be added to the axle loads specified. For rolling equipment without hammer blow (diesels, electric locomotives, tenders alone, etc.), the impact shall be equal to the following percentages of the live load:

- For  $L \leq 4\text{m}$ ,  $I = 60$  ..... (3.1)

- For  $4\text{m} < L \leq 39\text{m}$ ,  $I = 125/(L^{0.5})$  ..... (3.2)

- For  $L > 39\text{m}$ ,  $I = 20$  ..... (3.3)

Where, L is the span length in meters.

This formula is intended for ballasted-deck spans and substructure elements as required.

2. For continuous structures, the impact value calculated for the shortest span shall be used throughout.

3. Impact may be omitted in the design for massive substructure elements which are not rigidly connected to the superstructure.

4. For steam locomotives with hammer blow, the impact calculated shall be increased by 20%.

### 3.3.5 Centrifugal Force

1. On curves, a centrifugal force corresponding to each axle load shall be applied horizontally through a point 8 feet (2450 mm) above the top of rail measured along a

line perpendicular to the line joining the tops of the rails and equidistant from them.

This force shall be the percentage of the live load computed from the formulas below.

2. On curves, each axle load on each track shall be applied vertically through the point defined in the first paragraph of this article.
3. The greater of loads on high and low sides of a super elevated track shall be used for the design of supports under both sides.
4. The relationships between speed, degree of curve, centrifugal force and a super elevation which is 3 inches (75 mm) less than that required for zero resultant flange pressure between wheel and rail are expressed by the formulas:

$$CF = 0.000452S^2D \dots\dots\dots (3.4)$$

$$E_a = 0.0068S^2D - 75 \dots\dots\dots (3.5)$$

$$S = (E_a + 75)^{0.5}/(0.0068D)^{0.5} \dots\dots\dots (3.6)$$

Where,

CF = Centrifugal force in percentage of the live load

D = Degree of curve (Degrees based on 100 foot (30 m) chord)

E<sub>a</sub> = Actual super elevation in mm

S = Permissible speed in km/hr

### **3.3.6 Earth Pressure**

Earth pressure forces to be applied to the structure shall be determined in accordance with the provisions of indicated for Retaining Walls, Abutments and Piers in the manual.

### **3.3.7 Buoyancy**

Buoyancy shall be considered as it affects the design of either substructure, including piling, or the superstructure.

### **3.3.8 Wind Load on Structure**

The base wind load acting on the structure is assumed to be 45 lb per square foot (2160 Pa) on the vertical projection of the structure applied at the center of gravity of the

vertical projection in any horizontal direction. A base wind velocity of 100 miles per hour (160 km/h) was used to determine the base wind load. If an increase in the design wind velocity is made, the design wind velocity and design wind load shall be shown on the plans.

For Group II and Group V loadings, when a design wind velocity greater than 100 miles per hour (160 km/h) is advisable the base wind load may be increased by the ratio of the square of the design wind velocity to the square of the base wind velocity. This increase shall not apply to Group III and Group VI Loadings.

**3.3.9 Wind Load on Live Load**

A wind load of 300 lb per linear foot (4.4 KN/m) on the train shall be applied 8 feet (2450 mm) above the top of rail in a horizontal direction perpendicular to the centerline of the track.

**3.3.10 Longitudinal Force**

- I. The longitudinal force for E-80 (EM 360) loading shall be taken as the larger of:  
Force due to braking, as prescribed by the following equation, acting 8 feet (2450 mm) above top of rail.

$$\text{Longitudinal braking force (KN)} = 200 + 17.5L \dots\dots\dots (3.7)$$

Where, L is the length in meters of the portion of the bridge under consideration.

Force due to traction, as prescribed by the following equation, acting 3 feet (900 mm) above top of rail.

$$\text{Longitudinal traction force (KN)} = 200(L)^{0.5} \dots\dots\dots (3.8)$$

Where, L is the length in meters of the portion of the bridge under consideration

For design loads other than E-80 (EM 360), these forces shall be scaled proportionally. The points of force application shall not be changed.



- II. The effective longitudinal force shall be distributed to the various components of the supporting structure, taking into account their relative stiffness. The resistance of the backfill behind the abutments shall be utilized where applicable. The mechanisms (rail, bearings, load transfer devices, etc.) available to transfer the force to the various components shall also be considered.
- III. The longitudinal deflection of the superstructure due to longitudinal force computed in (1) above shall not exceed 1 inch (25 mm) for E-80 (EM 360) loading. For design loads other than E-80 (EM 360), the maximum allowable longitudinal deflection shall be scaled proportionally. In no case, however, shall the longitudinal deflection exceed 1-1/2 inches (38 mm).

### **3.3.11 Longitudinal Force Due to Friction or Shear Resistance at Expansion Bearings**

Provisions shall be made to accommodate forces due to friction or shear resistance due to expansion bearings.

### **3.3.12 Earthquake**

In regions where earthquakes may be anticipated, structures may be designed to resist earthquake motions by considering the relationship of the site to active faults, the seismic response of the soils at the site, and the dynamic response characteristics of the total structure. Refer to Chapter 9 Seismic Design for Railway Structures (AREMA Manual Volume II) for additional guidance.

### **3.3.13 Stream Flow Pressure**

All piers and other portions of structures which are subject to the force of flowing water or drift shall be designed to resist the maximum stresses induced thereby.

1. Stream Pressure

The effect of flowing water on piers and drift build up, assuming a second-degree parabolic velocity distribution and thus a triangular pressure distribution, shall be calculated by the formula:

$$P_{avg} = K_s (V_{avg})^2 \dots\dots\dots (3.9)$$

Where:

$P_{avg}$  = average stream pressure, in pounds per square foot, (Pa)

$V_{avg}$  = average velocity of water in feet per second, (m/s) computed by dividing the flow rate by the flow area,

$K_s$  = a constant, being 1.4 (or 725 for metric) for all piers subjected to drift build up and square-ended piers, 0.7 (or 360 for metric) for circular piers, and 0.5 (or 260 for metric) for angle-ended piers where the angle is 30 degrees or less.

## 2. Maximum Stream Flow Pressure

The maximum stream flow pressure,  $P_{max}$ , shall be equal to twice the average stream flow pressure,  $P_{avg}$ , computed by the equation given in (1) above. Stream flow pressure shall be a triangular distribution with  $P_{max}$  located at the top of water elevation and a zero pressure located at the flow line.

## 3. Pressure Components

When the direction of stream flow is other than normal to the exposed surface area, or when bank migration or a change of stream bed meander is anticipated, the effects of the directional components of stream flow pressure shall be investigated.

## 4. Drift Lodge Against Pier

Where a significant amount of drift lodge against a pier is anticipated, the effects of this drift build up shall be considered in the design of the bridge opening and the bridge components. The overall dimensions of the drift build up shall reflect the selected pier locations, site conditions, and known drift supply upstream. When it is anticipated that the flow area will be significantly blocked by drift buildup, increases in high water

elevations, stream velocities, stream flow pressures, and the potential increases in scour depths shall be investigated.

### **3.3.14 Ice Pressure**

The effects of ice pressure, both static and dynamic, shall be accounted for in the design of piers and other portions of the structure where, in the judgment of the Engineer, conditions so warrant.

### **3.3.15 Other Forces (Rib Shortening, Shrinkage, Temperature and/or Settlement of Supports)**

1. The structure shall be designed to resist the forces caused by rib shortening, shrinkage, temperature rise and/or drop and the anticipated settlement of supports.
2. The range of temperature shall generally be as shown in Table 3.1 (AREMA Table 8-2-3).

Table 3.1 Temperature Ranges

Climate	Temperature Rise	Temperature Fall
Moderate	17°C	22°C
Cold	20°C	25°C

### 3.4 LOADING COMBINATIONS

#### 3.4.1 General

The following groups represent various combinations of loads and forces to which a structure may be subjected. Each component of the structure, or the foundation on which it rests, shall be proportioned for the group of loads that produce the most critical design condition.

#### 3.4.2 Service Load Design

1. The group loading combinations for SERVICE LOAD DESIGN are as shown in Table 3.2.

Table 3.2 Group Loading Combinations – Service Load Design (AREMA Table 8-2-4)

Group	Item	Allowable Percentage of Basic Unit stress
I	D + L + I + CF + E + B + SF	100
II	D + E + B + SF + W	125
III	Group I + 0.5W + WL + LF + F	125
IV	Group I + OF	125
V	Group II + OF	140
VI	Group III + OF	140
VII	Group I + ICE	140
VIII	Group II + ICE	150

2. No increase in allowable unit stresses shall be permitted for members or connections carrying wind load only. If predictability of service load conditions is different from the specifications, this difference should be accounted for in the appropriate service load analyses or in the unit stress increase percentages.

### 3.4.3 Load Factor Design

1. The group loading combinations for LOAD FACTOR DESIGN are as shown in Table 3.3.

Table 3.3 Group Loading Combinations – Load Factor Design (AREMA Table 8-2-5)

Group	Item
I	$1.4 (D + 5/3 (L + I) + CF + E + B + SF)$
IA	$1.8 (D + L + I + CF + E + B + SF)$
II	$1.4 (D + E + B + SF + W)$
III	$1.4 (D + L + I + CF + E + B + SF + 0.5W + WL + LF + F)$
IV	$1.4 (D + L + I + CF + E + B + SF + OF)$
V	Group II + 1.4 (OF)
VI	Group III + 1.4 (OF)
VII	$1.0 (D + E + B + EQ)$
VIII	$1.4 (D + L + I + E + B + SF + ICE)$
IX	$1.2 (D + E + B + SF + W + ICE)$

2. The load factors given are only intended for designing structural members by the load factor concept. The actual loads should not be increased by these factors when designing for foundations (soil pressure, pile loads, etc.). The load factors are not intended to be used when checking for foundation stability (safety factors against overturning, sliding, etc.) of a structure. The load factors given above represent usual conditions and should be increased if, in the Engineer's judgment, the predictability of loads is different than anticipated by the specifications.

**4. GENERAL REQUIREMENTS AND MATERIALS FOR THE DESIGN OF RAILWAY  
STRUCTURES**

This section outlines the general requirements and materials properties which shall be used for the design of prestressed concrete members of railway structures supporting or protecting tracks.

All the Articles and Sub-Articles mentioned in this chapter refer to Part 2 (Reinforced Concrete Design) and Part 17 (Prestressed Concrete) of the American Railway Engineering and Maintenance-of-Way Association, 2010, Manual for Railway Engineering, Volume II unless cited.

**4.1 Details of Prestressing Tendons and Ducts**

**4.1.1 Spacing of tendons and ducts**

- a. The minimum clear distance between prestressing tendons at each end of a member shall not be less than 1-1/3 times the maximum size of the coarse aggregate. The minimum spacing center-to-center of tendon shall be as follows:

Table 4.1 Spacing of Tendons

Tendon Size	Spacing
1/2 inch special, 9/16 inch, 9/16 inch special, and 0.6 inch	2 inches (50 mm)
7/16 inch and 1/2 inch	1-3/4 inches (45 mm)
3/8 inch	1-1/2 inches (40 mm)

(Source: AREMA Manual Article 17.5.1)

- b. Clear distance between post-tensioning ducts or trumpets at each end of a member shall not be less than 1- 1/2 in. (40 mm) nor 1-1/2 times the maximum size of the coarse aggregate.

- c. Post-tensioning ducts may be bundled in groups of 3 maximum, provided the spacing limitations specified in Paragraph b are maintained in the end 3 feet (900 mm) of the member.
- d. Where pretensioning tendons are bundled, all bundling shall be done in the middle third of the beam length and the deflection points shall be investigated for secondary stresses.

**4.1.1 Minimum Concrete Cover**

For Cast-in-Place Concrete, the following minimum concrete cover shall be provided for prestressing tendons and non-prestressed reinforcement, and ducts:

- a. Post-tensioning ducts..... 3 in. (75 mm), but not less than  $d_d/2$ ,
- b. Non-prestressed reinforcement..... 2 in. (50 mm),
- c. Stirrups, ties and spirals ..... 2 in. (50 mm),
- d. Concrete cast against earth ..... 3 in. (75 mm).

**4.1.2 Post –Tensioning Ducts**

- a. Ducts shall be mortar-tight and nonreactive with concrete, tendons, or grout.
- b. Ducts for single wire, strand, or bar tendons shall have an inside diameter not less than ¼ in. (10 mm) larger than tendon diameter.
- c. Ducts for multiple wire, strand, or bar tendons shall have an inside cross sectional area not less than 2 times the net area of tendons.
- d. Ducts shall be maintained free of water.
- e. Ducts shall be grouted within twenty-four hours of post-tensioning, unless otherwise directed by the Engineer.

**4.2 General Analysis**

All members shall be designed for adequate strength and satisfactory behavior using these recommended practices as minimum guidelines. Behavior shall be determined by elastic analysis, taking into account the reactions, moments, shears, and axial forces

produced by prestressing, the effects of temperature, creep, shrinkage, axial deformation, restraint of attached structural elements, and foundation settlement.

#### **4.3 Span Length**

- a. The effective span lengths of simply supported beams shall be the distance center to center of bearings.
- b. The span length of continuous or restrained floor slabs and beams shall be the distance center to center of supports.

#### **4.4 Effective Flange Width**

- I. For composite prestressed construction where slabs or flanges are assumed to act integrally with the beam, the effective flange width shall conform to the provisions for T-girder flanges.
- II. For monolithic prestressed construction, with normal slab span and girder spacing, the effective flange width shall be the distance center-to-center of beams. For very short spans, or where girder spacing is excessive, analytical investigations shall be made to determine the effective width of flange acting with the beam.
- III. For monolithic prestressed design of isolated beams, the flange width shall not exceed 15 times the web width and shall be adequate for all design loads.
- IV. For cast-in-place box girders with normal slab span and girder spacing, where the slabs are considered an integral part of the girder, the entire slab width shall be assumed to be effective in compression.
- V. For box girders of unusual proportions, methods of analysis which consider shear lag shall be used to determine stresses in the cross section due to longitudinal bending.
- VI. Adequate fillets shall be provided at the intersections of all surfaces within the cell of a box girder, except at the junction of web and bottom flange where none are required.



#### **4.5 Flange and Web Thickness – Box Girders**

- a. The minimum top flange thickness shall be  $1/30$ th of the clear distance between fillets or webs but not less than 6 inches (150.00mm), except the minimum thickness may be reduced for factory produced precast, pretensioned elements to  $5 \frac{1}{2}$  inches (140.00mm).
- b. The minimum bottom flange thickness shall be  $1/30$ th of the clear distance between fillets or webs but not less than  $5 \frac{1}{2}$  inches (140.00mm), except the minimum thickness may be reduced for factory produced precast, pretensioned elements to 5 inches (130.00mm).
- c. Changes in girder stem thickness shall be tapered for a minimum distance of 12 times the difference in web thickness.

#### **4.6 Deflections**

- I. Flexural members of bridge structures shall be designed to have adequate stiffness to limit deflections or any deformations that may adversely affect strength and serviceability of the structure at service load. Members having simple or continuous spans shall be designed so that the deflection due to service live load plus impact does not exceed  $l/640$  of the span, where  $l$  is length of prestressing steel element from jack end to point under consideration.
- II. Deflections that occur immediately on application of load shall be computed by usual methods or formulas for elastic deflections, and moment of inertia of gross concrete section may be used for uncracked sections.
- III. Additional long-time deflection shall be computed taking into account stresses in concrete and steel under sustained load and including effects of creep and shrinkage of concrete and relaxation of prestressing steel.
- IV. Modulus of elasticity  $E_c$  for concrete and  $E_{si}$  for nonprestressed steel reinforcement shall be as specified in AREMA Article 2.23.4. Modulus of elasticity  $E_s$  for prestressing tendons shall be determined by tests or supplied by manufacturer.

#### **4.6.1 Computation of Deflections**

- a. Where deflections are to be computed, they shall be based on the cross-sectional properties of the entire superstructure section except railings, curbs, sidewalks or any element not placed monolithically with the superstructure section before false work removal. Deflections of composite members shall take into account shoring during erection, differential shrinkage of the elements and the magnitude and duration of load prior to the beginning of effective composite action.
- b. Computation of live load deflection may be based on the assumption that the superstructure flexural members act together and have equal deflection. The live loading shall consist of all tracks loaded as specified in AREMA Article 2.2.3c. The live loading shall be considered uniformly distributed to all longitudinal flexural members.

### **4.7 General Design**

#### **4.7.1 Design Theory and General Considerations**

Design of prestressed members shall be based on strength (LOAD FACTOR DESIGN) and on behavior at service load conditions (AREMA Article 17.6) at all load stages that may be critical during the life of the structure from the time prestressing is first applied.

#### **4.7.2 Basic Assumptions**

Strength design of prestressed members for flexure and axial loads shall be based on the following assumptions for design of monolithic members:

- a. Strains vary linearly over the depth of the member throughout the entire load range.
- b. Before cracking, stress is linearly proportional to strain.
- c. After cracking, tension in the concrete is neglected.

### **4.8 Load Factors**

#### **4.8.1 Required Strength**

- a. Prestressed members shall have design strengths at all sections at least equal to the required strengths calculated for the factored loads and forces in such combinations as stipulated in AREMA Article 2.2.4c for the load groups that are applicable. For the

design of post-tensioned anchorage zones, a load factor of 1.2 shall be applied to the maximum tendon jacking force.

b. The following strength capacity reduction factors shall be used:

I. For flexure:  $\phi = 0.95$ ,

II. For shear  $\phi = 0.90$ ,

III. For anchorage zones  $\phi = 0.85$  for normal weight concrete and  $\phi = 0.70$  for lightweight concrete.

## 4.9 Allowable Stresses

### 4.9.1 Prestressing Tendons

**4.9.1.1** Tensile stress in prestressing tendons shall not exceed the following:

- a. Due to tendon jacking force .....  $0.75f'_s$  or  $0.90f_y^*$  whichever is smaller, but not greater than the maximum value recommended by the manufacturer of the prestressing tendons or anchorages.
- b. Slight over stressing of pretensioning tendons up to  $0.85f'_s$  for short periods of time may be permitted to offset seating losses, provided the stress after seating does not exceed the value in Paragraph a.
- c. Stress-relieved pretensioning tendons immediately after prestress transfer.....  $0.82f_y^*$  or  $0.70f'_s$  whichever is larger.
- d. Stabilized (low-relaxation) pretensioning tendons immediately after prestress transfer.....  $0.82f_y^*$  or  $0.75f'_s$  whichever is larger.

**4.9.1.2** Tensile stress in post-tensioning shall not exceed the following:

- a. Immediately after tendon anchorage .....  $0.82f_y^*$  or  $0.70f'_s$  whichever is larger, but not greater than  $0.70f'_s$  at end anchorage.
- b. Over stressing of post-tensioning tendons up to  $0.90f'_s$  for short periods of time may be permitted to offset seating and friction losses provided the stress at the anchorage

does not exceed the value in Paragraph a above. The stress at the end of the seating loss zone must not exceed  $0.82f_y^*$  immediately after seating.

**4.9.2 Concrete**

**4.9.2.1** Stresses in concrete immediately after prestress transfer (before time-dependent prestress losses-Creep and Shrinkage) shall not exceed the following:

**a. Extreme fiber stress in compression**

- Pretensioned members.....  $0.60f_{ci}$
- Post-tensioned members.....  $0.55f_{ci}$

**b. Extreme fiber stress in tension**

1. Members without bonded auxiliary reinforcement..... 200 psi (1.38 MPa) or  $0.25(f'_{ci})^{1/2}$ (Metric). Where, the calculated tensile stress exceeds this value, bonded reinforcement shall be provided to resist the total tension force in the concrete computed on the assumption of an uncracked section.
2. Members with bonded auxiliary reinforcement provided in the tensile zone to resist the total tensile force in concrete computed with the assumption of an uncracked section.....  $0.623(f'_{ci})^{1/2}$ .

**4.9.2.2** Stresses in concrete at service loads (after allowance for all prestress losses) shall not exceed the following:

- Compression.....  $0.40f_c$
- Tension in the precompressed tensile zone..... 0,
- Tension in other areas is limited by allowable temporary stresses specified in AREMA Article 17.16.2.1.

**4.9.3 Cracking Stress**

Modulus of rupture from tests or if not available:

- For normal weight concrete.....  $0.623(f'_{ci})^{1/2}$ (Metric),
- For sand lightweight concrete.....  $0.523(f'_{ci})^{1/2}$ (Metric).

#### 4.9.4 Anchorage Bearing Stress

Post-tensioned anchorage at service load..... 3000 psi (21 MPa),  
but not to exceed  $0.9f'_{ci}$ .

#### 4.10 Loss of Prestress

**Loss of Prestress:** Reduction in prestressing force resulting from combined effects of strains in concrete and steel, including effects of elastic shortening, creep and shrinkage of concrete, relaxation of steel stress, friction, and anchorage seating.

##### 4.10.1 Prestress Losses

To determine effective prestress, allowance for the following sources of loss of prestress shall be considered:

$$\Delta f_s = ES + CR_c + SH + CR_s \dots\dots\dots (4.1)$$

Where,

ES =Elastic shortening of concrete

CR<sub>c</sub> =Creep of concrete

SH =Shrinkage of concrete

CR<sub>s</sub> =Relaxation of tendon stress

Anchorage seating and friction due to intended or unintended curvature in post-tensioning tendons shall be considered.

Loss of prestress may be determined by the following procedure for normal weight concrete and the following types of prestressing tendons.

For 270 ksi (1860 MPa) uncoated seven-wire stress-relieved or low-relaxation strand; 145 to 160 ksi (1000 to 1100 MPa) uncoated high-strength steel bar (plain or deformed):

## 1. Elastic shortening of Concrete

a. For Pre-tensioning members:

$$ES = (E_s/E_{ci})f_{cir} \dots\dots\dots (4.2)$$

b. For Post- Tensioning members:

$$ES = 0.5(E_s/E_{ci})f_{cir} \dots\dots\dots (4.3)$$

Where,

$E_s$  = modulus of elasticity of prestressing tendons

$E_{ci}$  = modulus of elasticity for concrete at time of transfer =  $W_c^{1.5}(0.0428)(f'_{ci})^{0.5}$  (MPa)

$f_{cir} = 0.69f'_s$

## 2. Creep of Concrete

For pretensioned and post-tensioned members:

$$CR_c = 12f_{cir} - 7f_{cds} \dots\dots\dots (4.4)$$

where:

$f_{cds}$  = stress in concrete at centroid of prestressing reinforcement, due to all dead load not included in calculation of  $f_{cir}$ .

## 3. Shrinkage of Concrete

a. For pretensioned members:

$$SH = 117 - 1.03 R \dots\dots\dots (4.5)$$

b. For post-tensioned members:

$$SH = 0.8 (117 - 1.03 R) \dots\dots\dots (4.6)$$

Where, R = annual average ambient relative humidity in percent.

## 4. Relaxation of Tendon Stress

a. For Pretensioning tendons:

- 1860 MPa stress-relieved strand tensioned to 0.70 $f'_s$

$$CR_s = 138 - 0.4 ES - 0.2 (SH + CR_c) \dots\dots\dots (4.7)$$

- 1860 MPa low-relaxation strand tensioned to 0.75 $f'_s$

$$CRs = 0.25(138 - 0.4 ES - 0.2 (SH + CRc)) \dots\dots\dots (4.8)$$

**b. For Post-tensioning tendons:**

- 1860 MPa stress-relieved strand anchored at 0.70f's

$$CRs = 138 - 0.3 FR - 0.4 ES - 0.2 (SH + CRc) \dots\dots\dots (4.9)$$

- 1860 MPa low-relaxation strand anchored at 0.75f's

$$CRs = 0.25(138 - 0.3 FR - 0.4 ES - 0.2 (SH + CRc)) \dots\dots\dots (4.10)$$

- 1000 to 1100 MPa high-strength steel bar

CRs = Loss due to relaxation should be based on approved test data.

If test data are not available, the loss may be assumed to be 21MPa.

Where,

FR = friction loss below 0.70f's at point being considered,

ES, SH, CRc = appropriate values as determined for either pretensioned or post-tensioned member.

**5. Anchorage Seating**

Allowance shall be made for loss of prestress in post-tensioning tendons due to anchorage seating. Calculations shall be made in accordance with a method consistent with the friction coefficients for the materials used.

**6. Friction**

Effect of friction loss due to intended or unintended curvature in post-tensioning tendons shall be computed by:

$$f_{fl} = f_{po} [1 - e^{-(Kx + \mu\alpha)}] \dots\dots\dots (4.11)$$

When  $(Kl_x + \mu\alpha)$  is not greater than 0.3, effect of friction loss may be computed by:

$$f_{fl} = f_{po}(Kx + \mu\alpha) \dots\dots\dots (4.12)$$

Table 4.2 Values for K and  $\mu$  (Source: AREMA Manual Table 8-17-1)

Type of Steel	Type of Duct	K	$\mu$
Uncoated wire or strand	Bright Metal Sheathing	0.0020 (0.0027)	0.30
	Galvanized Metal Sheathing	0.0015 (0.0020)	0.25
	Galvanized Rigid	0.0002 (0.00027)	0.25
	Polyethylene	0.0020 (0.0027)	0.25
Uncoated high strength bar	Bright Metal Sheathing	0.0003 (0.0004)	0.20
	Galvanized Metal Sheathing	0.0002 (0.00027)	0.15

However; based on past experiences, some literatures generally recommend average prestresses losses to be

- a. 22% for pretensioning, and
- b. 18% for post-tensioning assuming that over tensioning has been applied to overcome friction and anchorage set losses.

## 4.11 Flexural Strength

### 4.11.1 Introduction

Prestressed concrete members may be assumed to act as uncracked members subjected to combined axial and bending stresses within specified service loads. In calculations of section properties, the transformed area of bonded reinforcement may be included in pretensioned members and in post-tensioned members after grouting; prior to bonding of tendons, areas of the open ducts shall be deducted.



#### 4.11.2 Rectangular Sections

- I. For rectangular or flanged sections having prestressing steel only, in which the depth of the equivalent rectangular stress block, defined as  $(A_s^* f_{su}^*) / (0.85 f_c' b)$ , is not greater than the compression flange thickness “t”, the design flexural strength shall be assumed as:

$$\phi M_n = \phi [A_s^* f_{su}^* d \{1 - 0.6(\rho^* f_{su}^* / f_c')\}] \dots\dots\dots (4.13)$$

- II. For rectangular or flanged sections with non-prestressed tension reinforcement included, in which the depth of the equivalent rectangular stress block, defined as  $(A_s^* f_{su}^* + A_s f_{sy}) / (0.85 f_c' b)$ , is not greater than the compression flange thickness “t”, the design flexural strength shall be assumed as:

$$\phi M_n = \phi \{A_s^* f_{su}^* d [1 - 0.6((\rho^* f_{su}^* / f_c') + (d_t / d)(\rho f_{sy} / f_c'))] + A_s f_{sy} d_t [1 - 0.6((d / d_t)(\rho^* f_{su}^* / f_c') + (\rho f_{sy} / f_c'))]\} \dots\dots\dots (4.14)$$

#### 4.11.3 Flanged Sections

- I. For sections having prestressing steel only, in which the depth of the equivalent rectangular stress block, defined as  $(A_{sr} f_{su}^*) / (0.85 f_c' b')$  is greater than the compression flange thickness “t”, the design flexural strength shall be assumed as:

$$\phi M_n = \phi \{A_{sr} f_{su}^* d [1 - 0.6(A_{sr} f_{su}^* / b' d f_c')] + 0.85 f_c' (b - b')(t)(d - 0.5t)\} \dots\dots\dots (4.15)$$

Where,

$$A_{sr} = A_s^* - A_{sf} \dots\dots\dots (4.16)$$

$A_{sf}$  = The steel area required to develop the ultimate compressive strength of the overhanging portions of the flange.

$$A_{sf} = 0.85 f_c' (b - b') t / f_{su}^* \dots\dots\dots (4.17)$$

- II. For sections with non-prestressed tension reinforcement included, in which the depth of the equivalent rectangular stress block, defined as  $(A_{sr}f_{su}^*)/(0.85f'_c b')$  is greater than the compression flange thickness “t”, the design flexural strength shall be assumed as:

$$\phi M_n = \phi \{ A_{sr} f_{su}^* d [1 - 0.6 (A_{sr} f_{su}^* / b' d f'_c)] + A_s f_{sy} (d_t - d) + 0.85 f'_c (b - b') (t) (d - 0.5t) \} \dots\dots\dots (4.18)$$

Where,

$$A_{sr} = A_s^* + (A_s f_{sy} / f_{su}^*) - A_{sf} \dots\dots\dots (4.19)$$

$A_{sf}$  = The steel area required to develop the ultimate compressive strength of the overhanging portions of the flange

$$A_{sf} = 0.85 f'_c (b - b') t / f_{su}^* \dots\dots\dots (4.20)$$

#### 4.11.4 Steel Stress

As an alternative to a more accurate determination of  $f_{su}^*$  based on strain compatibility, the following approximate values of  $f_{su}^*$  shall be permitted to be used:

##### a. Bonded Members:

- I. with prestressing only (as defined):

$$f_{su}^* = f'_s [1 - (\dot{\gamma} / \beta_1) (p^* f'_s / f'_c)] \dots\dots\dots (4.21)$$

- II. with non-prestressed tension reinforcement included:

$$f_{su}^* = f'_s \{ 1 - (\dot{\gamma} / \beta_1) [(p^* f'_s / f'_c) + d_t / d (p f_{sy} / f'_c)] \} \dots\dots\dots (4.22)$$

Where,

- $\dot{\gamma} = 0.28$  for low-relaxation steel
- $= 0.40$  for stress-relieved steel
- $= 0.55$  for bar

**b. Unbonded members:**

$$f_{su}^* = f_{se} + 100 \dots\dots\dots (4.23)$$

provided that:

- a. The stress strain properties of the prestressing steel conform to the requirements of ASTM A416 (Low- Relaxation).
- b. The effective prestress after losses is not less than  $0.5f'_s$ .

**4.12 Ductility Limits**

**4.12.1 Maximum Prestressing Steel**

Prestressed concrete members shall be designed so that the steel is yielding as ultimate capacity is approached. In general, the reinforcement index shall be such that:

**For rectangular sections:**

$$\rho^* f_{su}^* / f'_c \dots\dots\dots (4.24)$$

**For flanged sections:**

$$A_{sr} f_{su}^* / b' d f'_c \dots\dots\dots (4.25)$$

But does not exceed  $0.36\beta_1$  for both cases.

For members with reinforcement indices greater than  $0.36\beta_1$ , the design flexural strength shall be assumed not greater than:

**For rectangular sections:**

$$\phi M_n = \phi [(0.36\beta_1 - 0.08\beta_1^2) f'_c b d^2] \dots\dots\dots (4.26)$$

**For flanged sections:**

$$\phi M_n = \phi [(0.36\beta_1 - 0.08\beta_1^2) f'_c b d^2 + 0.85 f'_c (b-b') t (d-0.5t)] \dots\dots\dots (4.27)$$

**4.12.2 Minimum Reinforcement**

The total amount of prestressed and non-prestressed reinforcement shall be adequate to develop an ultimate moment at the critical section at least 1.2 times the cracking moment

$M_{cr}^*$ .

$$\phi M_n \geq 1.2M_{cr}^* \dots\dots\dots (4.28)$$

Where,

$$M_{cr}^* = (f_r + f_{pe})S_c - M_{d/nc}(S_c/S_b - 1) \dots\dots\dots (4.29)$$

Appropriate values for  $M_{d/nc}$  and  $S_b$  shall be used for any intermediate composite sections. Where beams are designed to be non-composite, substitute  $S_b$  for  $S_c$  in the above equation for the calculation of  $M_{cr}^*$ .

**4.13 Non-Prestressed Reinforcement**

Non-prestressed reinforcement may be considered as contributing to the tensile strength of the beam at design flexural strength in an amount equal to its area times yield strength, provided that:

**For rectangular sections:**

$$(p f_{sy}/f'_c) d_t/d + (p^* f_{su}^*/f'_c) - (p' f_y/f'_c) \leq 0.361\beta_1 \dots\dots\dots (4.30)$$

**For flanged sections:**

$$(A_s f_{sy})/(b' d f'_c) + (A_{sr} f_{su}^*)/(b' d f'_c) - (A'_s f_y)/(b' d f'_c) \leq 0.36\beta_1 \dots\dots\dots (4.31)$$

**4.14 Shear**

**4.14.1 General**

**4.14.1.1** Prestressed concrete flexural members, except solid slabs and footings, shall be reinforced for shear and diagonal tension stresses. Voided slabs shall be investigated for shear, but shear reinforcement may be omitted if the factored shear force,  $V_u$ , is less than half the shear strength provided by the concrete  $\phi V_c$ .

**4.14.1.2** Web reinforcement shall consist of stirrups perpendicular to the axis of the member or welded wire fabric with wires located perpendicular to the axis of the member. Web reinforcement shall extend to a distance  $d$  from the extreme compression

fiber and shall be carried as close to the compression and tension surfaces of the member as cover requirements and the proximity of other reinforcement permit.

**4.14.1.3** Members subject to shear shall be designed so that

$$V_u \leq \phi(V_c + V_s) \dots\dots\dots (4.32)$$

Where,

$\phi$  is Strength Reduction Factor = 0.90 for Shear,

$V_u$  is the factored shear force at the section considered,

$V_c$  is the nominal shear strength provided by concrete, and

$V_s$  is the nominal shear strength provided by web reinforcement.

**4.14.1.4** When the reaction to the applied loads introduces compression into the end regions of the member, sections located at a distance less than  $h/2$  from the face of the support may be designed for the same shear  $V_u$  as that computed at a distance  $h/2$ . An exception occurs when major concentrated loads are imposed between that point and the face of support. In that case sections closer than  $d$  to the support shall be designed for  $V_u$  at distance  $d$  plus the major concentrated loads.

**4.14.2 Shear Strength Provided by Concrete**

**4.14.2.1** For members with effective prestress force not less than 40 percent of the total tensile strength of flexural reinforcement, shear strength  $V_c$  shall be computed by:

$$V_c = [0.05(f'_c)^{0.5} + 5V_u d_p / M_u] b_w d \dots\dots\dots (4.33)$$

But  $V_c$  need not be taken

- less than  $(f'_c)^{0.5} b_w d / 6$ ,
- nor shall  $V_c$  be taken greater than  $0.4(f'_c)^{0.5} b_w d$  nor the value  $V_{cw}$  (given below).

(Note:  $V_{cw}$  = nominal shear strength provided by concrete when diagonal cracking results from excessive principal tensile stress in web).

The quantity  $V_u d_p / M_u$  shall not be taken greater than 1.0, where  $M_u$  is factored moment occurring simultaneously with factored shear force,  $V_u$  at the section considered.

**4.14.2.2** For more precise analysis the shear strength provided by concrete,  $V_{cr}$ , shall be taken as the lesser of the values  $V_{ci}$  or  $V_{cw}$ .

The shear strength,  $V_{ci}$ , shall be computed by:

$$V_{ci} = 5 \times 10^{-4} (f'_c)^{1/2} b' d + V_d + V_i * M_{cr} / M_{max} \dots\dots\dots (4.34)$$

But  $V_{ci}$  need not be less than  $220(f'_c b' d)^{1/2}$  and  $d$  need not be taken less than  $0.8h$ .

The moment causing flexural cracking at the section due to externally applied loads,  $M_{cr}$ , shall be computed by:

$$M_{cr} = (I/y_t) ((0.5f'_c)^{1/2} + f_{pe} - f_d) \dots\dots\dots (4.35)$$

Where,

$I$  = moment of inertia about the centroid of the cross section,

$y_t$  = distance from centroidal axis of gross section, neglecting reinforcement, to extreme fiber in tension,

$f'_c$  = compressive strength of concrete at 28 days,

$f_{pe}$  = compressive stress in concrete due to effective prestress forces only (after allowance for all prestress losses) at extreme fiber of section where tensile stress is caused by externally applied loads,

$f_d$  = stress due to unfactored dead load, at extreme fiber of section where tensile stress is caused by externally applied loads.

The maximum factored moment and factored shear at the section due to externally applied loads,  $M_{max}$  and  $V_i$ , shall be computed from the load combination causing maximum moment at the section.

The shear strength,  $V_{cw}$ , shall be computed by:

$$V_{cw} = 10 \times 10^{-5} [(0.29(f'_c)^{0.5} + 0.3f_{pe}) b'd] + V_p \dots\dots\dots (4.36)$$

but d need not be taken less than 0.8h.

**4.14.3 Shear Strength Provided by Web Reinforcement**

Shear reinforcement shall consist of stirrups perpendicular to axis of member or welded wire fabric with wires located perpendicular to axis of member.

**4.14.3.1 The shear strength provided by web reinforcement shall be taken as**

$$V_s = (A_v f_{sy} d) / s \dots\dots\dots (4.37)$$

Where,  $A_v$  is the area of web reinforcement within a distance  $s$ .

$V_s$  shall not be taken greater than  $0.66(f'_c)^{0.5} b'd$  and  $d$  need not be taken less than 0.8h.

**4.14.3.2** The spacing of web reinforcing shall not exceed 0.75h or 24 inches (600 mm).

When  $V_s$  exceeds  $0.332(f'_c)^{0.5} b'd$ , this maximum spacing shall be reduced by one-half.

**4.14.3.3 Minimum Shear Reinforcement**

A minimum area of shear reinforcement shall be provided in all flexural members, except: slabs, footings, and shallow beams, where factored shear force  $V_u$  exceeds  $\frac{1}{2}$  the shear strength provided by concrete  $\phi V_c$ , (Beams with total depth not greater than either 10 in. (250 mm), 2-1/2 times the thickness of the flange, or one-half the width of web shall be considered shallow beams).

The minimum area of web reinforcement shall be:

$$A_v = (0.345b's) / f_{sy} \dots\dots\dots (4.38)$$

Where,  $b'$  and  $s$  are in mm and  $f_{sy}$  is in MPa.

**4.14.3.4** The design yield strength of web reinforcement,  $f_{sy}$ , shall not exceed 60,000 psi (420 MPa).

#### **4.15 T-Girder Construction**

- a. In T-girder construction, the girder web and slab shall be built integrally or otherwise effectively bonded together. Full transfer of shear forces shall be assured at the interface of web and slab.
- b. Compression Flange Width
  - I. The effective slab width acting as a T-girder flange shall not exceed one-fourth of the span length of the girder, and its overhanging width on either side of the girder shall not exceed six times the thickness of the slab or one-half the clear distance to the next girder.
  - II. For girders having a slab on one side only, the effective overhanging flange width shall not exceed  $1/12$  of the span length of the girder, nor 6 times the thickness of the slab, nor one-half the clear distance to the next girder.
  - III. Isolated T-girders in which the flange is used to provide additional compression area shall have a flange thickness not less than one-half the width of the girder web and a total flange width not more than four times the width of the girder web.
  - IV. For integral bent caps, the effective overhanging slab width on each side of a bent cap web shall not exceed six times the least slab thickness, nor  $1/10$  the span length of the bent cap. For cantilevered bent caps, the span length shall be taken as two times the length of cantilever span.

#### **4.16 Box Girder Construction**

- a. In box girder construction, the girder web and top and bottom slab shall be built integrally or otherwise effectively bonded together. Full transfer of shear forces shall be assured at the interfaces of the girder web with the top and bottom slab.
- b. Compression Flange Width
  - I. For box girder flanges, the entire slab width shall be assumed effective for compression.



II. For integral bent caps, the effective overhanging slab width on each side of a bent cap web shall not exceed six times the least slab thickness, nor 1/10 the span length of the bent cap. For cantilevered bent caps, the span length shall be taken as two times the length of cantilever span.

c. Top and Bottom Slab Thickness

I. The thickness of the top slab shall be designed to resist all the loads, but shall be not less than the minimum specified in Table 4.3.

Table 4.3 Recommended Minimum Thickness for Constant Depth Members

Superstructure Type	Minimum Thickness (m)*
Bridge slabs with main reinforcement parallel or perpendicular to traffic	$(S+3)/20$ but not less than 0.23
T-Girders	$(S + 2.75)/15$
Box Girders	$(S + 3)/17$
<p><b>* Recommended values for simple spans; continuous spans may be about 90% of thickness given.</b></p> <p><b>S = Slab Clear Span in meters.</b></p>	

(Source: AREMA Manual Table 8-2-10)

II. The thickness of the bottom slab shall be not less than 1/16 of the clear span between girder webs or 6 inches (150 mm), whichever is greater, except that the thickness need not be greater than the top slab unless required by design.

d. Top and Bottom Slab Reinforcement

I. Minimum distributed reinforcement of 0.4% of the flange area shall be placed in the bottom slab parallel to the girder span. A single layer of reinforcement may be provided. The spacing of such reinforcement shall not exceed 18 inches (450 mm).

- II. Minimum distributed reinforcement of 0.5% of the cross-sectional area of the slab, based on the least slab thickness, shall be placed in the bottom slab transverse to the girder span. Such reinforcement shall be distributed over both surfaces with a maximum spacing of 18 inches (450 mm). All transverse reinforcement in the bottom slab shall extend to the exterior face of the outside girder web in each group and be anchored by a standard 90 degree hook.
- III. At least 1/3 of the bottom layer of the transverse reinforcement in the top slab shall extend to the exterior face of the outside girder web in each group and be anchored by a standard 90 degree hook. If the slab extends beyond the last girder web, such reinforcement shall extend into the slab overhang and shall have an anchorage beyond the exterior face of the girder web not less than that provided by a standard hook.

**4.17 Structural Depth**

For Prestressed Continuous Spans, the Structural depth h shall be determined from:

$$h = 0.04L \dots\dots\dots (4.39)$$

Where, L is span of the structure (AASHTO LRFD, Table 2.5.2.6.3-1).

**4.18 Web Thickness**

The minimum web thickness is specified to be 7in. (175.00mm).

**4.19 Number of Cells**

The number of cell box to be used shall be determined based on the following relationship:

$$h/b \geq 0.17, \text{ use single cell box} \dots\dots\dots (4.40)$$

$$h/b < 0.17, \text{ use double cell box} \dots\dots\dots (4.41)$$

Where, h is the structural depth and b is the width of the top flange.

#### 4.20 Spacing of Girders

The spacing of girders is generally taken no more than twice their depth (BRIDGE ENGINEERING HAND BOOK, 2000).

$$\text{Girders Spacing} \leq 2 \cdot h \dots\dots\dots (4.42)$$

#### 4.21 Secondary (Hyperstatic) Moments in Post-Tensioning

In addition to the primary moments ( $P \cdot e_p$ ), secondary moments ( $M_{sec.}$ ) are introduced in continuous structures as the prestressing is applied. Secondary moments develop in a prestressed member due to prestressing forces, and as a consequence of the constraint provided by the supports to the free movement of the prestressed member. If a prestressed member is allowed to displace freely, as in the case of determinate structures or precast members prior to alignment and installation, no secondary moments are generated. However, in most cast-in-place construction, where supports constrain movement of the prestressed member, secondary actions can be significant and therefore must be accounted for in the design (Aalami, 1998).

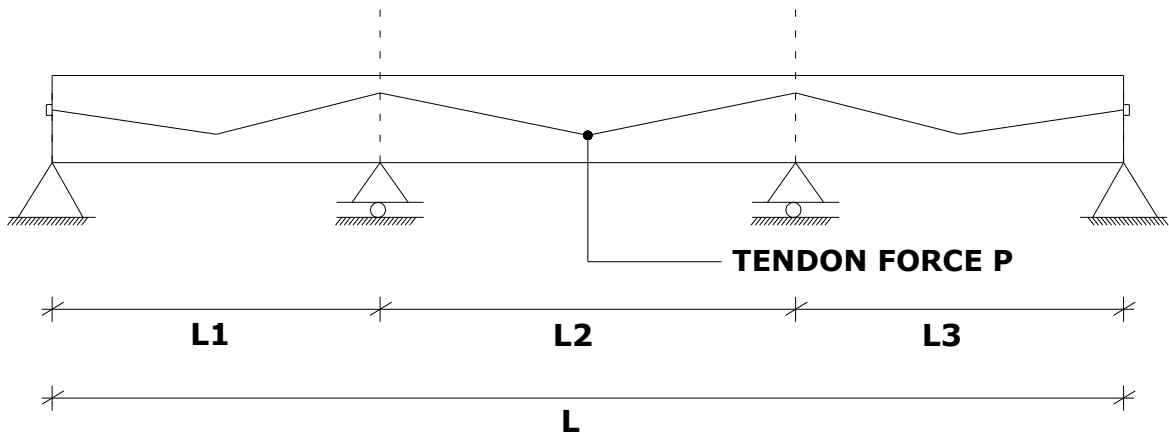

Figure 4.1 Three Span Post-Tensioned Beam

Consider a three span post-tensioned beam which was cast and stressed prior to installation. Before installation, the tendon forces cause the beam camber indicated by the curved soffit in Figure 4.2 below.

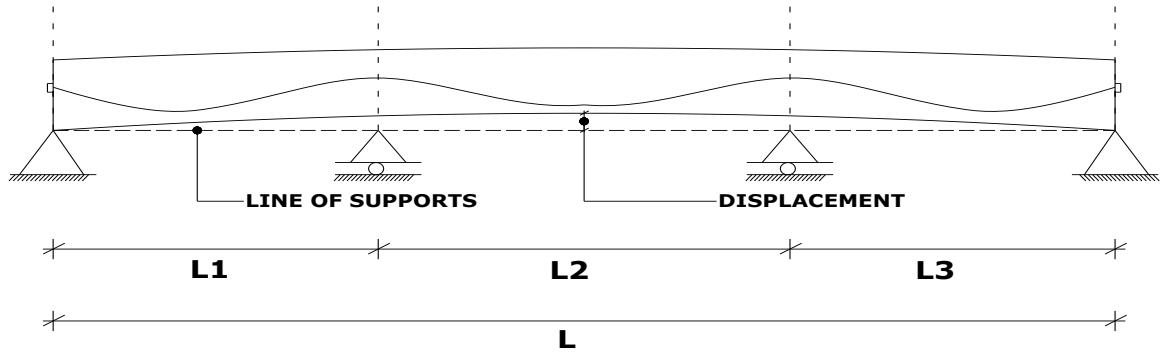

Figure 4.2 Beam subjected to Prestressing Force only (Aalami, 1998)

The camber is due solely to the deflection of the beam under the action of the prestressing tendons as if the interior supports were not there. However, in practice the beam would be restrained at interior supports, and in order to resist the upward displacements of the structure at those positions, downward reactions must be induced at the supports.

Reactions, which are required to restrain the upward movement of the beam at interior supports, would then induce secondary moments. Figure 4.3 shows the reactions required to restrain the vertical movement of the structure at interior supports of a continuous structure.

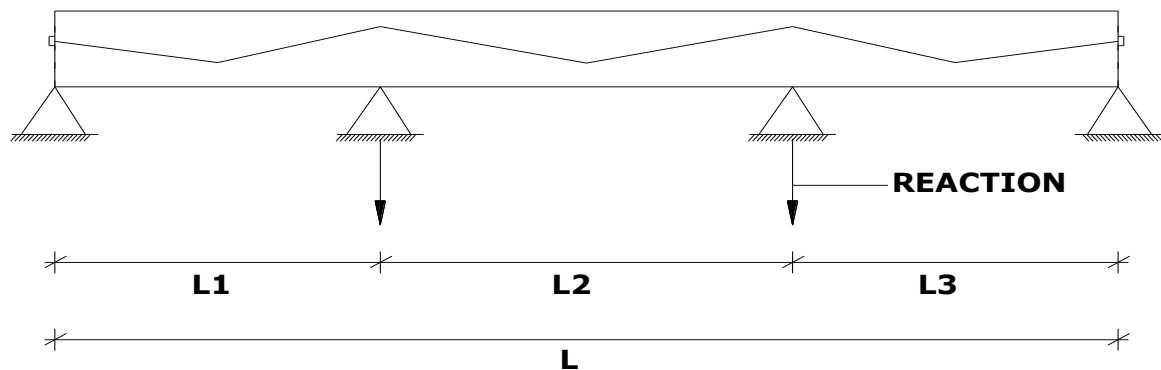

Figure 4.3 Reactions at Interior Supports due to Prestressing Force (Aalami, 1998)

Note that the secondary moment diagram varies linearly between supports since it is produced by the reactions at interior supports which are induced by the prestressing force.

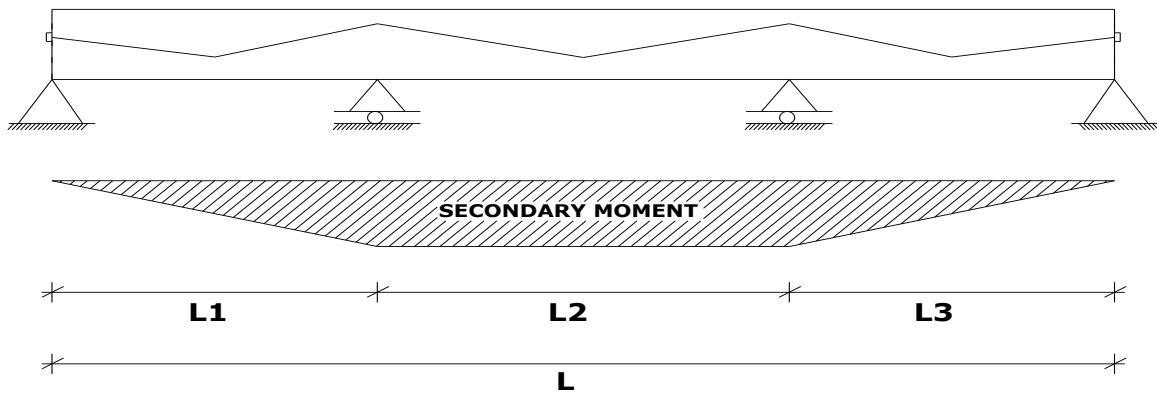

Figure 4.4 Secondary Moments Distribution (Aalami, 1998)

In most continuous structures secondary moments have the effect of increasing the magnitude of the positive moment at interior supports and reducing the negative moment between supports. Once the secondary moments have been determined, the total stresses can be checked by adding the total prestress moments (i.e. primary and secondary moments) and the bending moments due to the applied loads (dead loads, live loads, etc.). Note that secondary moment is not factored because, in most cases, it counteracts the moments due to dead and live loading.

However, the effects of the secondary moments can be considered to be negligible if the tendon profile is concordant. Concordant cable is a tendon profile in which the eccentricity is proportional to the bending moment due to all acting loads on a rigidly supported statically indeterminate (or continuous) structure. In such cases, there shall not be any reactions induced at the supports due to the prestressing force and the secondary moments are zero as a result.

In order to determine the secondary moments, the designer needs to identify the tendon profile to be used and the equivalent load exerted by the tendon on the structure must

be determined first. Once the equivalent tendon loads are known, the secondary moment ( $M_{sec.}$ ) can be determined from the relationship

$$M_{balanced} = M_1 + M_{sec.} \dots\dots\dots (4.43)$$

Where, the balanced load moment ( $M_{balanced}$ ) is the magnitude of the moment under the action of the balanced loads and  $M_1$  is the primary moment which is equal to  $P_{se} * e_p$  at the section being considered. In other words, the balanced load moment is the total moment which is equal to the superposition of the primary and secondary moments at any section considered. Note that the balanced load is the magnitude of load which shall be counter acted by the action of the prestressing force applied to the structure.

Now, let's consider the different forms of tendon profiles which can be used for post-tensioned structures and the respective equivalent tendon loads:

Case I: Simply supported beam with a parabolic tendon profile:

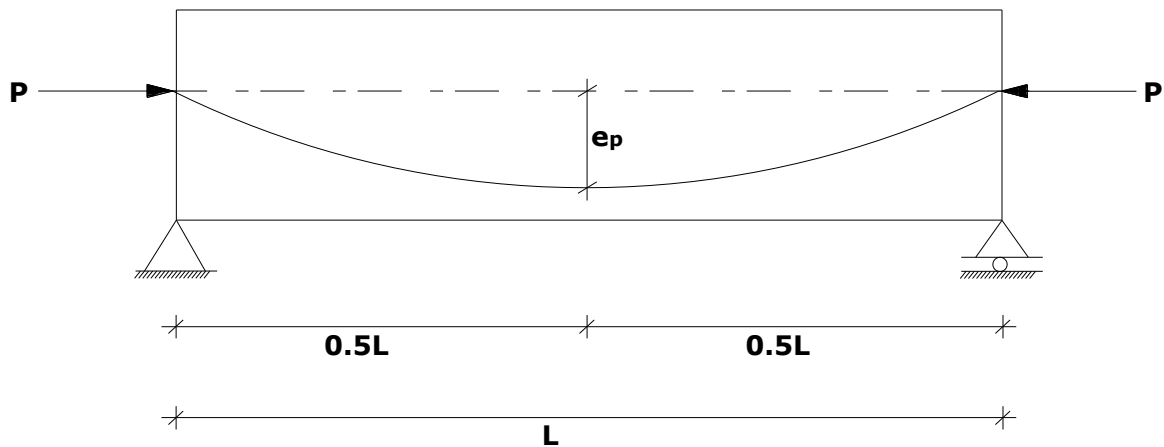

Figure 4.5 Simply Supported Beam with Parabolic Tendon Profile

The equivalent loads acting on the beam consist of the axial force  $P$  and an upward uniform load  $w_t$  which are exerted by the tendons.

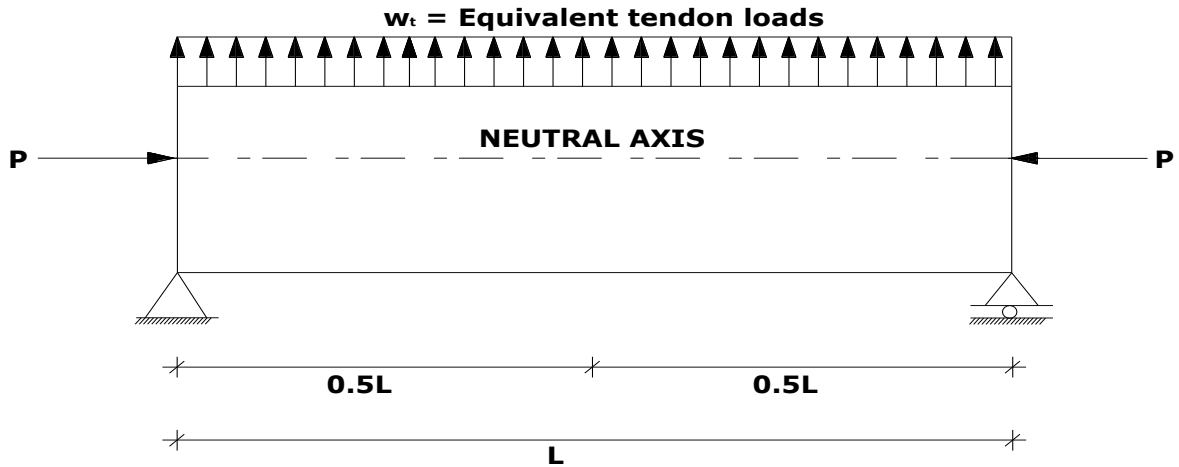

Figure 4.6 Equivalent Tendon Loads Applied to the Simply Supported Beam

Case II: A three span post-tensioned continuous structure with parabolic tendon profile for the first two spans and straight for the third one.

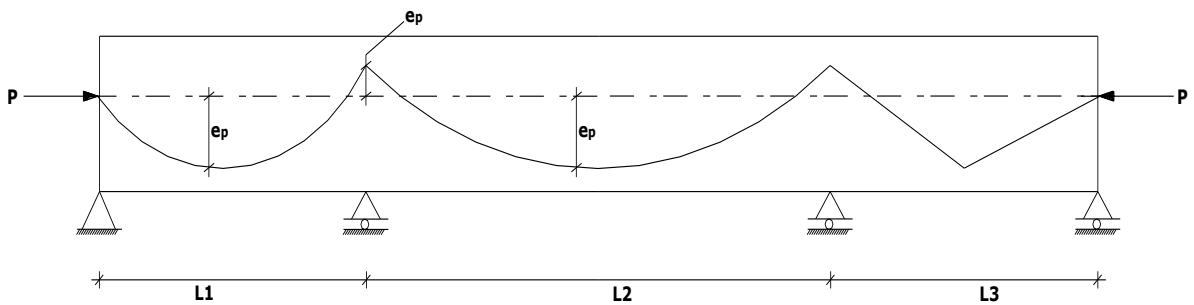

Figure 4.7 Typical Tendon Profile for a Three Span Continuous Structure

This tendon configuration actually exerts uniformly distributed equivalent upward load on the structure where the tendon profile is parabolic; and an upward concentrated load for a straight tendon profile.

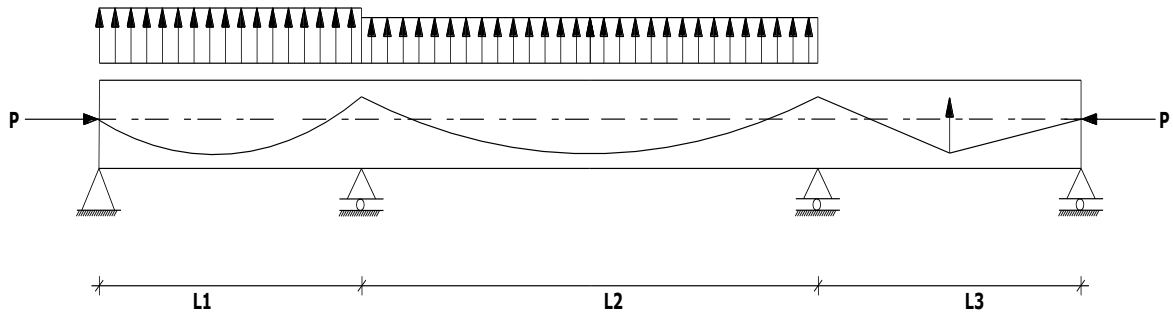

Figure 4.8 Equivalent Tendon Loads Exerted on the Continuous Structure

For all the parabolic tendon profiles, the equivalent upward tendon load applied to the beam can be determined as (John P. Miller, 2012):

$$w_t = (8 * P * e_p) / L^2 \dots\dots\dots (4.44)$$

Where, L is the length between the two sections considered and P is the Prestressing force. Then, the balanced load will be equal in magnitude to the equivalent upward tendon load but opposite in direction.

## 4.22 Post-Tensioned Anchorages Zones

### 4.22.1 Geometry of Anchorage Zone

The anchorage zone is geometrically defined as the volume of concrete through which the concentrated prestressing force at the anchorage device spreads transversely to a linear stress distribution across the entire cross section.

- For anchorage zones at the end of a member or segment, the transverse dimensions may be taken as the depth and width of the section.
- The longitudinal extent of the anchorage zone in the direction of the tendon (ahead of anchorage) shall be taken as not less than the larger transverse dimension but not more than one and one-half times that dimension.



For design purposes, the anchorage zone shall consist of two regions; the general zone and the local zone.

**General Zone:** The region in front of the anchor which extends along the tendon axis for a distance recommended by codes or standards.

**Local Zone:** The region immediately surrounding each anchorage device.

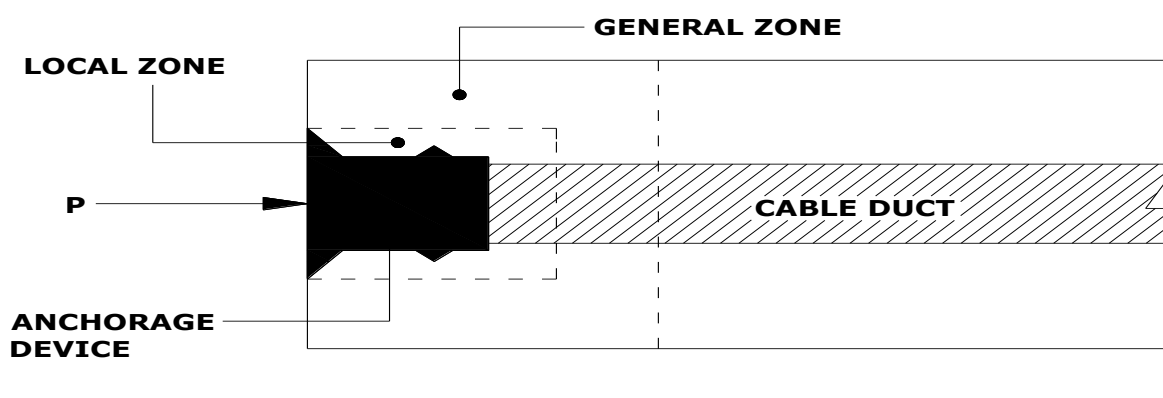

Figure 4.9 Post-Tensioning Anchorage Zones (VSL-INTERNATIONAL, 1991)

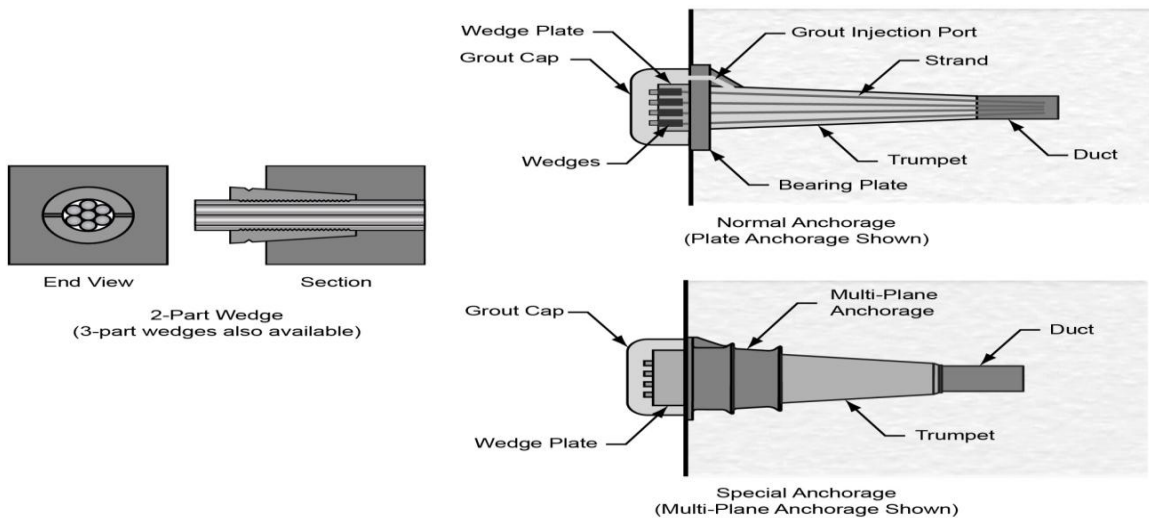

Figure 4.10 Typical Post-Tensioning Anchorage Devices  
(Courtesy of US Department of Transportation, Federal Highway Administration Manual, 2013)

#### **4.22.2 General Zone**

The geometric extent of the general zone is identical to that of the overall anchorage zone as defined above and includes the local zone.

#### **4.22.3 Design Methods**

The following methods may be used for the design of general zones:

- a. Equilibrium based plasticity models (strut-and-tie models),
- b. Elastic stress analysis (finite element analysis or equivalent),
- c. Approximate methods for determining the compression and tension forces, where applicable.

#### **4.22.4 Nominal Material Strengths**

The nominal tensile strength of bonded reinforcement is limited to  $f_{sy}$  for non-prestressed reinforcement and to  $f_y$  for prestressed reinforcement.

The effective nominal compressive strength of the concrete of the general zone, exclusive of confined concrete, is limited to  $0.7f'_c$ .

**4.22.4.1** Compressive stresses in the concrete ahead of basic anchorage devices shall meet the requirements of the bearing strength.

#### **4.22.5 Local Zone**

The local zone is defined as the rectangular prism (or equivalent rectangular prism for circular or oval anchorages) of concrete surrounding and immediately ahead of the anchorage device and any integral confining reinforcement.

**4.22.5.1 Dimensions of the Local Zone**

- a. When no independently verified manufacturer’s edge distance recommendations for a particular anchorage device are available, the transverse dimensions of the local zone in each direction shall be taken as the larger of:
  - I. The corresponding bearing plate size plus twice the minimum concrete cover required for the particular application and environment.
  - II. The outer dimension of any required confining reinforcement plus the required concrete cover over the confining reinforcing steel for the particular application and environment.
- b. The length of the local zone along the tendon axis shall be taken as the greater of:
  - I. The maximum width of the local zone.
  - II. The length of the anchorage device confining reinforcement.
  - III. For anchorage devices with multiple bearing surfaces, the distance from the loaded concrete surface to the bottom of each bearing surface plus the maximum dimension of that bearing surface.

In no case shall the length of the local zone be taken as greater than one and one-half times the width of the local zone.

- c. For closely spaced anchorages an enlarged local zone enclosing all individual anchorages shall also be considered.

**4.23 Bearing Strength**

The effective concrete bearing compressive strength  $f_b$  used for design shall not exceed

$$f_{br} \leq 0.7f'_{ci} (A/A_{gb})^{0.5} \dots\dots\dots (4.45)$$

but,

$$f_{br} \leq 2.25f'_{ci} \dots\dots\dots (4.46)$$

Where,

$f'_{ci}$  = the concrete compressive strength at stressing,

$A$  = the maximum area of the portion of the supporting surface that is geometrically similar to the loaded area and concentric with it,

$A_{gb}$  = the gross area of the bearing plate.

#### 4.24 Bursting Forces in Anchorage Zones

For post-tensioned members, the prestressing force in a tendon is applied through the anchorage as a concentrated force. The stress distribution in a member is reasonably uniform away from the anchorage, but in the region of the anchorage itself the stress distribution within the concrete is complex. The most significant effect for design, however, is that tensile stresses are set up transverse to the axis of the member, tending to split the concrete apart. Thus, spiral reinforcements are provided within the anchorage zones to contain these tensile stresses (Hurst, 2003).

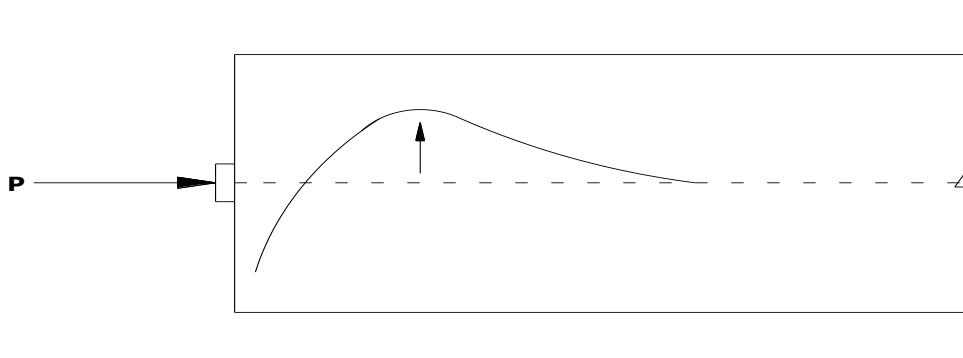

Figure 4.11 Bursting Forces in the Anchorage Zone (Hurst, 2003)

We will use the following **a strut-and-tie model** to determine the reinforcement which are required to resist the bursting forces in the anchorage zone.

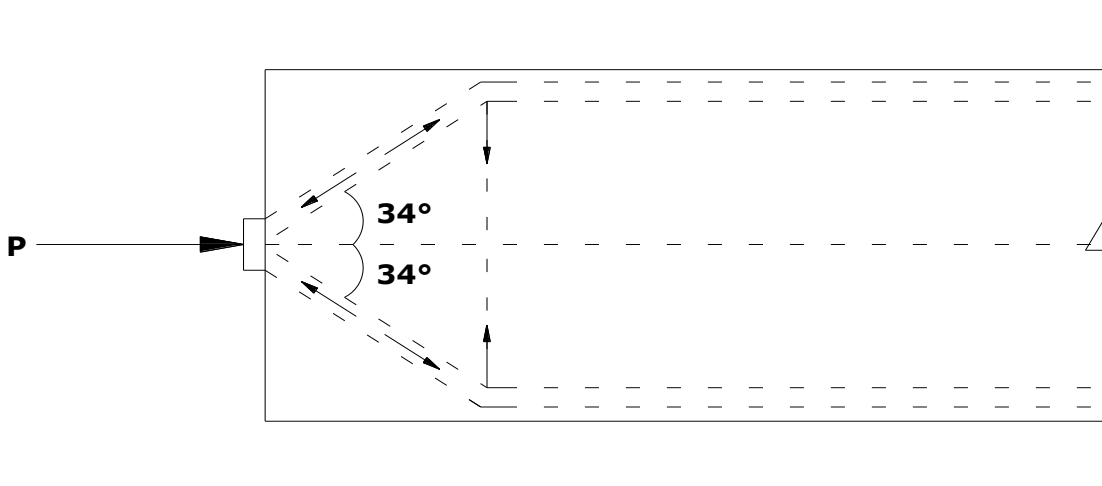

Figure 4.12 Strut-and-Tie Model of the Anchorage Zone (Hurst, 2003)

## 5. DESIGN OF PRESTRESSED CONCRETE RAILWAY BRIDGES

### 5.1 Background

This thesis is a design-based study which completely relies on the outputs of the structural analysis, the corresponding adequate sections required, and the reinforcements provided for the structure. In this regard, the design of a three span continuous post-tensioned concrete railway bridge shall be undertaken varying the lengths of each segment in order to determine the approximate construction costs of the bridge superstructures and thereby to identify the economical span combination of the structure under consideration. A number of span combinations can randomly be made using the given total length of the bridge, i.e. 100m, and the number of spans, which are three.

Since the width of the bridge is kept constant for all cases, the first decision need to be made is which span combination shall result in the minimum the construction costs of the structures. In this regard, for a three span continuous bridge different literatures, referring to chapter 2, recommend a span combination which results in the largest possible negative moments at the piers; smaller positive moments and girder deflections at the span. In addition, all these previous studies have used a symmetrical span arrangement on either side of the interior span, i.e. to keep the lengths of the exterior spans equal, for a three span continuous bridge to obtain an optimum design. Arranging the exterior spans symmetrically on either side of the interior one would be advantageous in order to obtain balanced moments at the supports for an optimum design. However; it is also better to observe the results of the span combinations by using unequal lengths of the exterior spans, finally to arrive at sound conclusions. Thus, we will use both symmetrical and unsymmetrical span combinations, and consider all the available options for a three span continuous bridge with a total length of 100.00m.

## 5.2 Design Parameters

Some of the parameters which shall be used for the design are taken from the Design Report of the Addis Ababa Light Rail Transit (AA-LRT) Project. In addition to those reports which are obtained from the Ethiopian Railways Corporation, assumptions shall be made whenever required in order to make the design of the structures complete.

### The following parameters shall be used for the design process:

- Span of the Bridge to be considered: 100.00m,
- The number of span of the Bridge: 3 (Three) spans,
- Types of Bridge Sections to be analyzed: T and Box Girders,
- The number of tracks (railway lines) on the Bridge: 1 (One),
- Track Gauge (distance between the inner sides of the rails): Standard Gauge = 1435.00mm,
- Length of the Track Ties (Sleepers): 2,200.00mm,
- Ballasted Track: Depth =400mm,
- Total width of the Bridge: 5,035.00mm,
- Super Imposed Dead Load: Track rails, inside guardrails and fastenings = 3kN/m; Ballast including track ties = 1900 kg/m<sup>3</sup>,
- Concrete Curb Area (Assumed): 0.14m<sup>2</sup>,
- Live Load: Cooper E80 Bridge Loading.

## 5.3 Materials Properties

### I. Concrete:

- Grade of Concrete: C50,
- Unit weight of Concrete: 25KN/m<sup>3</sup>.

### II. Prestressing Steel (Source: DYWIDAG Bonded Post-Tensioning Systems):

- Prestressing Steel: 7-Wire Low-Relaxation Strands (Nominal Diameter = 15.24mm),
- Nominal Area: 140.00mm<sup>2</sup>,

- Weight: 1.102Kg/m,
- Ultimate Tensile Strength: 1,860 MPa,
- Yield Strength: 1,670 MPa,
- Modulus of Elasticity:  $1.95 \times 10^5$ MPa.

### III. Standard Dimensions of Corrugated (Metal) Cable Ducts for 15.2mm Strands:

Table 5.1 Standard Dimensions of Cable Ducts

No.	Sheathing (Duct)	
	Internal Diameter (mm)	Outer Diameter (mm)
1	20.00	25.00
2	40.00	45.00
3	50.00	55.00
4	55.00	60.00
5	60.00	65.00
6	65.00	70.00
7	75.00	80.00
8	80.00	85.00
9	90.00	95.00
10	95.00	100.00
11	100.00	105.00
12	110.00	118.00
13	120.00	128.00
14	130.00	138.00

(Source: DYWIDAG Bonded Post-Tensioning Systems)

### IV. Nominal Reinforcement Bars:

- Tensile Strength: 400.00 MPa,
- Yield Strength: 347.83 MPa,



- Modulus of Elasticity: 210.00 MPa.

#### 5.4 Design Assumptions

- The structure is found on a straight line; thus no need to consider Centrifugal Force.
- The vertical and horizontal alignment requirements are considered to be satisfied.
- The prestressing force is assumed to be the same at all sections of the structure.
- Cross section of the structure is prismatic, i.e. depth is constant at any section of the structure.
- The following loadings are considered not to be existing:
  - ✓ Earth Pressure,
  - ✓ Buoyancy,
  - ✓ Wind Force on the Structure,
  - ✓ Wind Force on Live Load,
  - ✓ Longitudinal Force,
  - ✓ Earth quake,
  - ✓ Stream Flow Pressure,
  - ✓ Ice Pressure.
- The prestressing construction shall be monolithic, where the slabs are considered to act integrally with the beam for both T and Box-Girder Bridges.
- Use of Bonded Tendons (Prestressing tendon that is bonded to concrete either directly or through grouting).
- The following unit prices shall be used for the purpose of bridge superstructure cost estimation:
  - a.) C50 Concrete: Birr 4,000.00/m<sup>3</sup>,
  - b.) Form Work to Concrete: Birr 400/m<sup>2</sup>,
  - c.) Prestressed Tendons: Birr 400.00/m,
  - d.) Nominal Reinforcement Bars: Birr 40.00/Kg.

## 5.5 Design Steps

Generally, for the purpose of undertaking the design of prestressed concrete railway bridges, we will follow the following steps:

**STEP 1:** Select the span combination (i.e. identify L1, L2, and L3).

**STEP 2:** Determine cross-section geometry.

- Structural depth (use equation 4.39),
- Determine the number of cell boxes (or girders use equation 4.40, 4.41, 4.42),
- Determine the web thickness (assume and check against Section 4.18) ,
- Determine the top flange thickness (assume and check against Table 4.3),
- Determine the bottom flange thickness (for box girder: Section 4.16.c (II)).

**STEP 3:** Determine cross-section properties.

- Determine location of the centroid,
- Determine the moment of inertia of the section,
- Determine the section moduli (top and bottom) of the section.

**STEP 4:** Determine the design values (i.e. shear force and bending moment according to AREMA Article 2.30.1).

**STEP 5:** Determine the permissible stresses in prestressing tendons and in concrete (refer to Section 4.9).

**STEP 6:** Determine the cable path (set trial eccentricities at span and at support).

**STEP 7:** Determine the required prestressing force.

**STEP 8:** Determine the required number of strands.

**STEP 9:** Check stresses in concrete at transfer.

**STEP 10:** Check stresses in concrete at end anchorages at transfer.

**STEP 11:** Check stresses in concrete at service loads.

**STEP 12:** Check stresses in concrete at end anchorages at service loads.

**STEP 13:** Determine secondary moments due to the application of the prestressing force.

Check the flexural strength of the section (use equation 4.14, 4.15, 4.18 or 4.18).

**STEP 14:** Check the ultimate flexural strength of the section.

**STEP 15:** Check ductility limits (i.e. maximum prestressing steel and minimum reinforcement using equation 4.24, 4.25, 4.26, 4.27, 4.28 or 4.29).

**STEP 16:** Design for shear (use equations 4.32, 4.33, 4.34, 4.35 4.36, 4.37, and 4.38).

**STEP 17:** Check deflections.

**STEP 18:** Check bearing stress under the anchorage steel plate (use equations 4.43 and 4.44).

**STEP 19:** Determine the reinforcement required to resist the bursting stresses (use the Strut-and-Tie Model shown in Figure 4.8).

**STEP 20:** Estimate the construction cost of the bridge superstructure.

For the purpose of undertaking this thesis, the variables used to estimate the construction costs of the bridge superstructure are the volume of structural concrete; formwork to the structural concrete; the lengths of the prestressing tendons; and mild (Non-prestressing steel) reinforcement bars.

## 5.6 Design Algorithm

The following design algorithm shall be used to undertake design of a three span continuous post-tensioned concrete railway bridge.

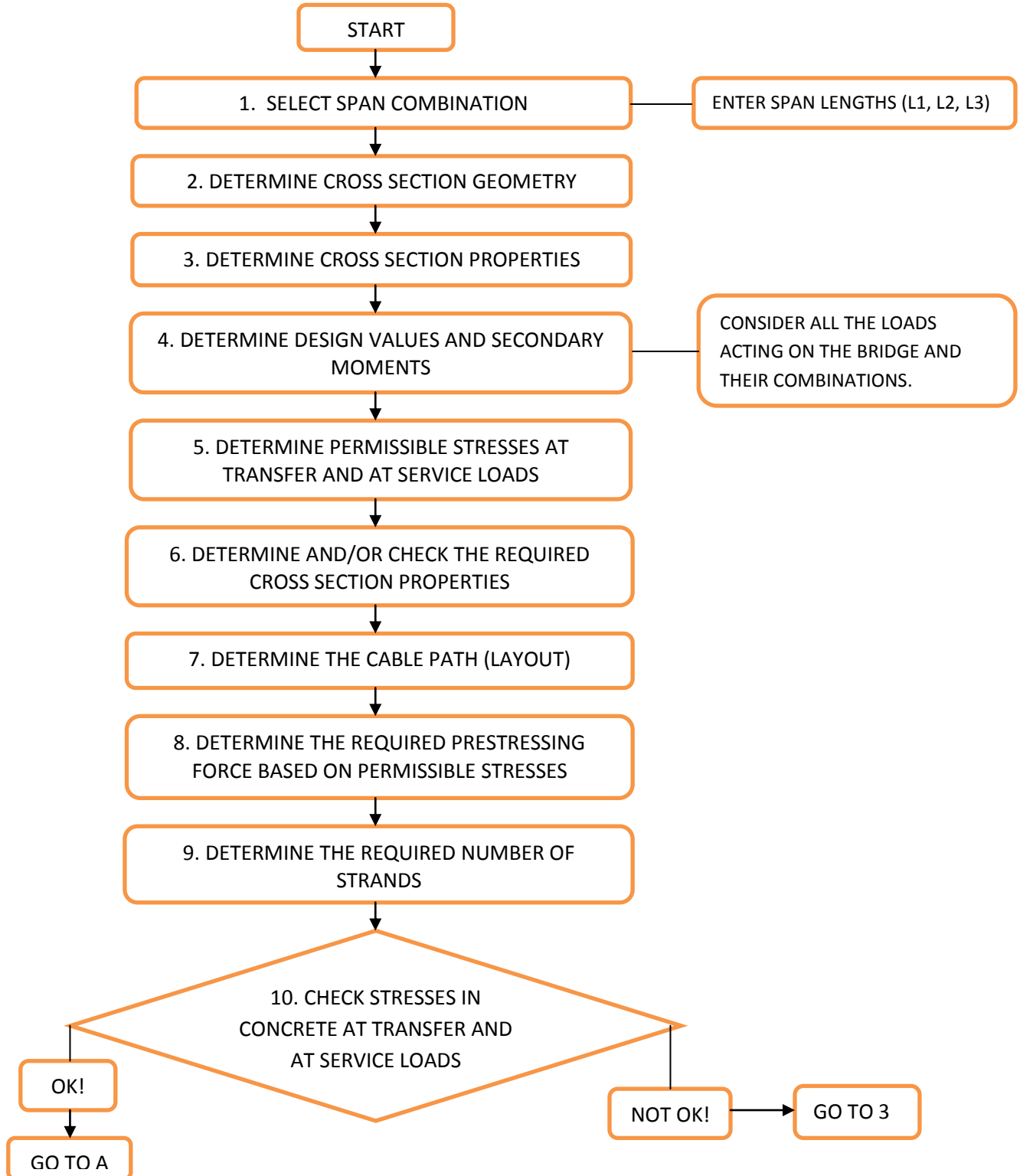

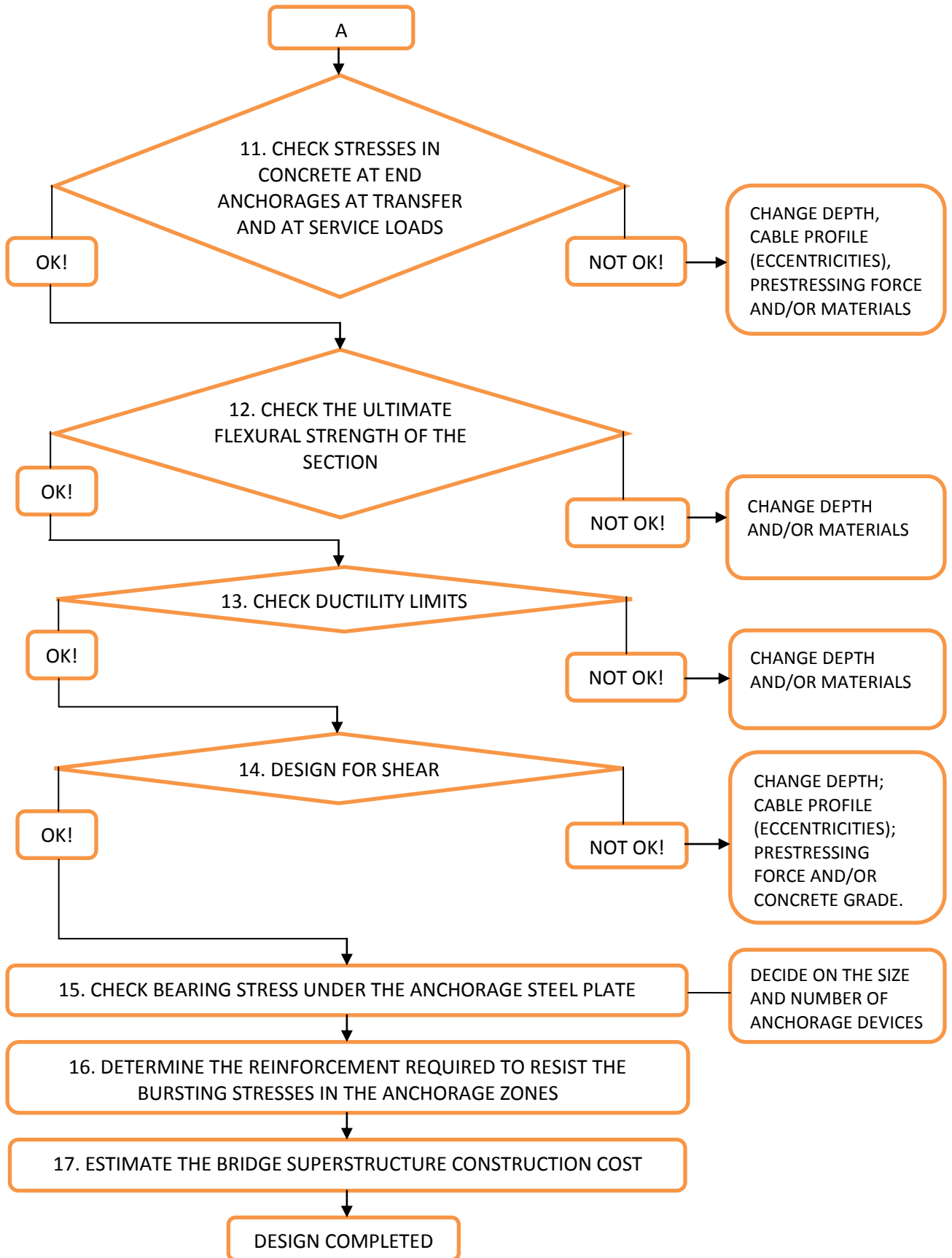

## **6. FINDINGS OF THE STUDY**

The findings of the thesis shall be presented in such a way that the objectives set forth at the beginning are met. In this regard, complete design of a three span continuous post-tensioned railway bridge has been undertaken using different span combinations, and thereby estimating the respective construction cost of the structures adopting the procedures stipulated in chapter 5.

Consequently; summaries of the whole design outputs of 100.00m long three span continuous post-tensioned concrete railway bridge, using ox and T- Girder sections, are presented below.

Table 6.1 Summary of the Cost Estimations of a Three Span Post-Tensioned Railway Bridge

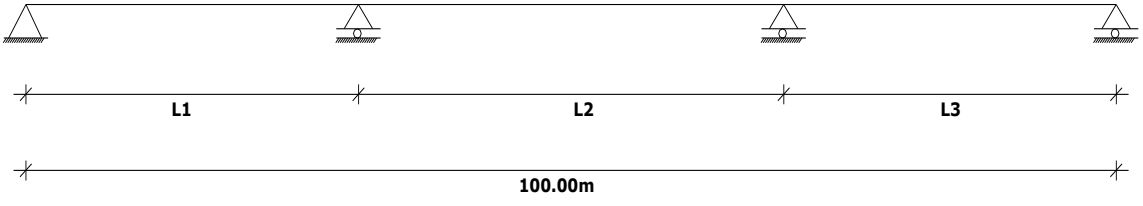

**A THREE SPAN CONTINUOUS BRIDGE**

**A THREE SPAN 100.00m LONG CONTINUOUS POST TENSIONED RAILWAY BRIDGE COST ESTIMATION (SUMMARY)**

No.	SPAN COMBINATION			ESTIMATED CONSTRUCTION COST (ETB)	
	L1 (m)	L2 (m)	L3 (m)	BOX GIRDER	T - GIRDER
1	20.00	60.00	20.00	18,427,636.46	21,221,694.17
2	21.00	58.00	21.00	15,131,636.98	19,939,656.93
3	22.00	56.00	22.00	15,372,000.28	17,622,276.52
4	23.00	54.00	23.00	15,492,646.63	17,607,700.52
5	24.00	52.00	24.00	14,777,732.20	16,791,091.70
6	25.00	50.00	25.00	14,236,031.89	15,941,615.62
7	26.00	48.00	26.00	13,489,792.71	15,405,269.03
8	27.00	46.00	27.00	13,489,792.71	15,405,269.03
9	28.00	44.00	28.00	12,392,264.61	12,573,874.87
10	29.00	42.00	29.00	11,737,821.22	11,861,759.51
11	30.00	40.00	30.00	11,230,601.29	13,142,180.87
12	32.00	36.00	32.00	10,388,701.44	13,400,262.82
13	31.00	38.00	31.00	10,907,782.48	12,834,293.40
14	31.00	39.00	30.00	11,253,543.77	13,204,410.91
15	33.00	32.00	35.00	11,154,726.17	12,632,153.29
16	33.00	34.00	33.00	10,643,139.58	12,363,636.97
17	33.00	33.00	34.00	10,875,538.37	12,450,720.01
18	33.00	35.00	32.00	11,086,009.76	12,773,822.41
19	33.00	36.00	31.00	11,040,038.69	12,653,340.60
20	33.33	33.33	33.33	10,542,710.11	12,226,445.23
21	34.00	32.00	34.00	10,460,019.29	12,152,217.74
22	34.00	34.00	32.00	10,843,497.19	12,615,905.22
23	34.00	35.00	31.00	11,013,136.53	12,766,231.24
24	34.00	36.00	30.00	11,372,648.47	13,285,298.56
25	35.00	30.00	35.00	10,650,626.70	12,060,710.34
26	35.00	33.00	32.00	11,161,919.39	12,697,222.10

27	35.00	34.00	31.00	11,414,551.53	13,248,456.26
28	35.00	35.00	30.00	11,579,817.36	13,514,092.05
29	35.00	36.00	29.00	11,833,632.57	13,709,205.22
30	36.00	28.00	36.00	10,701,997.39	12,394,696.70
31	36.00	30.00	34.00	12,066,066.61	12,800,284.39
32	36.00	32.00	32.00	11,283,922.44	13,096,912.82
33	36.00	33.00	31.00	11,448,072.67	13,307,277.64
34	36.00	34.00	30.00	12,287,757.18	13,556,138.29
35	36.00	35.00	29.00	11,762,404.62	13,755,354.09
36	36.00	36.00	28.00	12,016,494.48	14,066,668.79
37	37.00	26.00	37.00	12,016,494.48	14,066,668.79
38	38.00	24.00	38.00	11,281,732.38	13,042,239.46
39	39.00	22.00	39.00	11,151,396.47	13,557,718.63
40	40.00	20.00	40.00	11,663,487.90	14,853,274.87
<b>ECONOMICAL (OPTIMUM) CONSTRUCTION COST</b>				<b>10,388,701.44</b>	<b>11,861,759.51</b>
<b>ECONOMICAL (OPTIMUM) SPAN COMBINATION</b>				<b>32.00 - 36.00 - 32.00</b>	<b>29.00 - 42.00 - 29.00</b>
<b>ECONOMICAL (OPTIMUM) SPAN COMBINATION</b>				<b>L - 1.13L - L</b>	<b>L - 1.45L - L</b>

Summaries of quantities of construction materials required for the box and T-girders are tabulated below.

<b>Table 6.2 SUMMARY OF QUANTITIES OF MATERIALS REQUIRED FOR BOX GIRDERS</b>							
<b>No.</b>	<b>SPAN COMBINATION</b>			<b>QUANTITIES OF MATERIALS REQUIRED FOR BOX GIRDERS</b>			
	<b>L1 (m)</b>	<b>L2 (m)</b>	<b>L3 (m)</b>	<b>C50 CONCRETE (m<sup>3</sup>)</b>	<b>FORM WORK (m<sup>2</sup>)</b>	<b>15.24mm TENDONS (m)</b>	<b>MILD REINFORCEMENT (Kg)</b>
1	20.00	60.00	20.00	718.10	1,460.00	36,664.25	7,638.29
2	21.00	58.00	21.00	679.41	1,460.00	28,387.51	11,874.59
3	22.00	56.00	22.00	641.74	1,362.90	29,541.16	11,085.25
4	23.00	54.00	23.00	605.09	1,314.14	30,566.82	7,997.78
5	24.00	52.00	24.00	569.45	1,265.39	29,200.77	7,836.48
6	25.00	50.00	25.00	534.83	1,216.65	28,258.77	7,663.41
7	26.00	48.00	26.00	509.54	1,180.09	26,556.04	8,929.88
8	27.00	46.00	27.00	484.81	1,143.54	25,425.04	8,921.34
9	28.00	44.00	28.00	460.66	1,106.99	24,444.83	8,222.44
10	29.00	42.00	29.00	444.88	1,082.63	22,991.55	8,216.16
11	30.00	40.00	30.00	429.35	1,058.26	21,903.45	8,213.17
12	32.00	36.00	32.00	460.66	1,106.99	19,219.56	10,386.08



13	31.00	38.00	31.00	414.07	1,033.90	21,343.34	7,514.87
14	31.00	39.00	30.00	421.68	1,046.08	22,120.69	7,503.12
15	33.00	32.00	35.00	406.53	1,021.72	21,760.84	10,389.53
16	33.00	34.00	33.00	395.34	1,003.45	20,683.32	9,677.10
17	33.00	33.00	34.00	399.05	1,009.54	21,220.64	9,681.40
18	33.00	35.00	32.00	402.78	1,015.63	21,775.08	8,964.77
19	33.00	36.00	31.00	406.53	1,021.72	21,618.36	8,947.10
20	33.33	33.33	33.33	395.34	1,003.45	20,360.12	10,398.31
21	34.00	32.00	34.00	395.34	1,003.45	20,153.40	10,398.31
22	34.00	34.00	32.00	402.78	1,015.63	21,096.68	9,685.99
23	34.00	35.00	31.00	410.29	1,027.81	21,506.89	8,952.05
24	34.00	36.00	30.00	425.50	1,052.17	22,301.38	8,230.24
25	35.00	30.00	35.00	395.34	1,003.45	20,557.79	11,119.52
26	35.00	33.00	32.00	414.07	1,033.90	21,762.32	9,678.51
27	35.00	34.00	31.00	421.68	1,046.08	22,306.84	9,666.76
28	35.00	35.00	30.00	429.35	1,058.26	22,704.37	8,934.38
29	35.00	36.00	29.00	437.08	1,070.44	23,248.11	8,947.23
30	36.00	28.00	36.00	399.05	1,009.54	20,570.43	11,845.03
31	36.00	30.00	34.00	501.23	1,167.91	23,235.70	7,492.49
32	36.00	32.00	32.00	421.68	1,046.08	21,908.15	10,387.97
33	36.00	33.00	31.00	429.35	1,058.26	22,302.89	9,655.59
34	36.00	34.00	30.00	534.83	1,216.65	23,406.86	7,475.63
35	36.00	35.00	29.00	444.88	1,082.63	22,980.89	8,937.37
36	36.00	36.00	28.00	452.74	1,094.81	23,526.26	8,928.08
37	37.00	26.00	37.00	406.53	1,021.72	20,968.16	12,553.16
38	38.00	24.00	38.00	414.07	1,033.90	21,773.37	12,563.37
39	39.00	22.00	39.00	437.08	1,070.44	21,109.80	13,274.51
40	40.00	20.00	40.00	452.74	1,094.81	22,211.01	13,255.36

<b>Table 6.3 SUMMARY OF QUANTITIES OF MATERIALS REQUIRED FOR T-GIRDERS</b>							
<b>No.</b>	<b>SPAN COMBINATION</b>			<b>QUANTITIES OF MATERIALS REQUIRED FOR T-GIRDERS</b>			
	<b>L1 (m)</b>	<b>L2 (m)</b>	<b>L3 (m)</b>	<b>C50 CONCRETE (m<sup>3</sup>)</b>	<b>FORM WORK (m<sup>2</sup>)</b>	<b>15.24mm TENDONS (m)</b>	<b>MILD REINFORCEMENT (Kg)</b>
1	20.00	60.00	20.00	803.22	1,250.00	42,544.61	12,274.26
2	21.00	58.00	21.00	760.30	1,250.00	39,802.55	11,936.09
3	22.00	56.00	22.00	718.49	1,166.49	34,577.46	11,268.25
4	23.00	54.00	23.00	677.80	1,124.75	35,041.26	10,752.63
5	24.00	52.00	24.00	638.22	1,083.02	33,484.87	10,276.68

6	25.00	50.00	25.00	599.75	1,041.29	31,831.65	9,835.98
7	26.00	48.00	26.00	562.40	999.57	30,946.96	9,426.76
8	27.00	46.00	27.00	526.16	957.86	30,394.74	8,965.79
9	28.00	44.00	28.00	544.14	978.71	23,669.33	13,452.66
10	29.00	42.00	29.00	526.16	957.86	22,171.80	12,631.69
11	30.00	40.00	30.00	465.42	884.87	26,488.60	8,278.05
12	32.00	36.00	32.00	473.89	895.29	27,027.71	8,387.98
13	31.00	38.00	31.00	448.69	864.02	25,922.24	8,125.74
14	31.00	39.00	30.00	457.02	874.44	26,743.24	8,231.57
15	33.00	32.00	35.00	444.55	923.39	25,406.92	8,045.65
16	33.00	34.00	33.00	428.17	837.96	24,999.28	7,901.36
17	33.00	33.00	34.00	436.33	848.38	25,115.09	8,000.58
18	33.00	35.00	32.00	436.33	848.38	25,922.85	8,000.58
19	33.00	36.00	31.00	444.55	858.81	25,524.47	8,045.65
20	33.33	33.33	33.33	428.17	837.96	24,656.31	7,901.36
21	34.00	32.00	34.00	428.17	837.96	24,470.74	7,901.36
22	34.00	34.00	32.00	436.33	848.38	25,528.06	8,000.58
23	34.00	35.00	31.00	444.55	858.81	25,806.69	8,045.65
24	34.00	36.00	30.00	461.21	879.66	26,896.01	8,254.81
25	35.00	30.00	35.00	432.24	843.17	24,049.60	9,365.98
26	35.00	33.00	32.00	452.85	869.23	25,530.51	8,148.62
27	35.00	34.00	31.00	457.02	874.44	26,859.23	8,172.82
28	35.00	35.00	30.00	465.42	884.87	27,418.38	8,278.05
29	35.00	36.00	29.00	473.89	895.29	27,800.06	8,387.98
30	36.00	28.00	36.00	432.24	843.17	24,884.57	9,365.98
31	36.00	30.00	34.00	444.55	858.81	25,819.71	8,766.87
32	36.00	32.00	32.00	457.02	874.44	26,474.49	8,231.57
33	36.00	33.00	31.00	465.42	884.87	26,901.34	8,278.05
34	36.00	34.00	30.00	473.89	895.29	27,417.39	8,387.98
35	36.00	35.00	29.00	482.42	905.72	27,808.28	8,501.45
36	36.00	36.00	28.00	491.03	916.15	28,485.27	8,549.43
37	37.00	26.00	37.00	440.43	853.59	25,286.93	10,186.76
38	38.00	24.00	38.00	448.69	864.02	26,225.74	10,289.38
39	39.00	22.00	39.00	465.42	884.87	27,311.08	10,441.69
40	40.00	20.00	40.00	482.42	905.72	30,408.84	9,943.88

## 7. CONCLUSIONS AND RECOMMENDATIONS

### 7.1 CONCLUSIONS

#### 7.1.1 Economical Span Combination

Referring to the summary of the results tabulated in chapter 6, it can, therefore, be concluded that the economical span combination of a three span continuous post-tensioned railway bridge, with a total length of 100.00m, is

- a. 32.00 – 36.00 – 32.00m (L – 1.13L – L) for box girder, and
- b. 29.00 – 42.00 – 29.00m (L – 1.45L – L) for T-girder sections.

The optimum span combinations are highly dependent on the unit price of the 15.24mm prestressing steel tendon since it has taken the major cost of the bridge superstructure. The results will be different if we use the unit price of the 15.24mm prestressing steel tendon other than the one which have been used in this study, i.e. 400 Birr/m (or nearly 20.00 USD/m).

#### 7.1.2 Economical Section

Results of this study has revealed that the economical section of a three span continuous post-tensioned railway bridge, with a total length of 100.00m, is found to be Box Girder while comparing it with a T-Girder in all cases of different span combinations. The findings of the study have revealed that box girder sections are always economical than the T-girder sections for a three span continuous post-tensioned railway bridges with a total lengths near 100.00m.

### 7.1.3 Further Research

This study focuses on optimization of span arrangements of 100m long three-span continuous post-tensioned concrete railway bridges using constant depth sections. Analysis on continuous bridges with spans less or more than 100.00m with non-prismatic and some other different sections needs further study since a wider range of span arrangement and different options are variable.

## 7.2 RECOMMENDATIONS

This study has focused on determining the economical span arrangement and economical section for a three span continuous post-tensioned railway bridge with a total length of 100.00m.

Consider an elevated section of the Addis Ababa Light Rail Transit Project with a length of 100.00m:

- Five segments of 19.90m span; and
- Six supports are used.

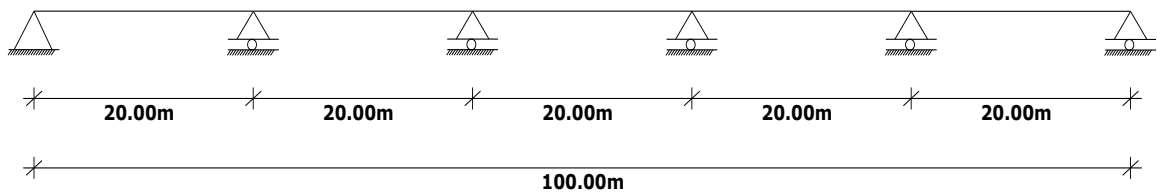

Figure 7.1 AA-LRT Project Typical Elevated Section

However; if we use a three span continuous structure for the elevated section being considered:

- Only four supports are required; and
- Additional circulation area would be secured by eliminating the two interior supports (especially in congested urban areas).

Generally, examining summary of the results of the study which have been presented in the previous chapter, and assessing use of continuous structures as an alternative options for elevated railway sections, the following recommendations and conclusions can generally be made:

1. It will be advantageous to arrange a three span post-tensioned railway bridges in such a manner that the interior span is longer than the exterior or end spans provided that other bridge design requirements shall be satisfied.
2. Box girder bridges are the famous and economical sections than the T-girder ones for a three span continuous post-tensioned railway lines with spans up to 100.00m length.
3. Use continuous structures in congested urban areas for elevated railway sections to allow for additional circulation spaces for other traffic, and to add the aesthetical value of the structures.
4. Arrange the exterior spans of a three span bridges symmetrically on either side of the interior span so that it would be advantageous in order to obtain balanced moments at the supports for an optimum design.

## APPENDICES

## **A. MATERIALS SPECIFICATIONS**

## MATERIALS PROPERTIES

### I. CONCRETE

- Grade of Concrete: C50
- Unit Weight of Concrete,  $W_c = 25.00\text{KN/m}^3$
- Cylindrical Compressive Strength of Concrete at 28 days,  $f'_c = 50/1.25 = 40.00\text{MPa}$
- Assume Compressive Strength of Concrete at time of initial Prestress,  $f'_{ci} = 36.00\text{MPa}$
- Modulus of Elasticity of Concrete,  $E_c = w_c^{1.5} * 0.043 * f'_c^{1/2}$  .....AREMA Art. 2.23.4  
 $E_c = 33,994.48\text{MPa}$  (AT 28 DAYS)  
 $E_c = 32,250.00\text{MPa}$  (AT INITIAL PRESTRESS)

### II. PRESTRESSING STEEL

- Prestressing Steel: 7-Wire Low-Relaxation Strands (Nominal Diameter = 15.24mm),
- Nominal Area:  $140.00\text{mm}^2$ ,
- Weight:  $1.102\text{Kg/m}$ ,
- Ultimate Tensile Strength:  $1,860\text{ MPa}$ ,
- Yield Strength:  $1,670\text{ MPa}$ ,
- Modulus of Elasticity:  $1.95 \times 10^5\text{MPa}$ . (Source: DYWIDAG Bonded Post-Tensioning Systems)



### **III. MILD REINFORCEMENT BARS (NON-PRESTRESSED REINFORCEMENT)**

- Mild Steel Reinforcement Grade = S-400
- Tensile Strength,  $f_y = 400.00\text{MPa}$
- Yield Strength,  $f_{sy} = 347.83\text{MPa}$
- Modulus of Elasticity,  $E_{si} = 2.10 \times 10^5\text{MPa}$

### **SIGN CONVENTION**

#### **I. CONCRETE**

- POSITIVE (+ve) = COMPRESSION
- NEGATIVE (-ve) = TENSION

#### **II. PRESTRESSING STEEL**

- POSITIVE (+ve) = TENSION
- NEGATIVE (-ve) = COMPRESSION

#### **III. MOMENTS**

- NEGATIVE (-ve) = TENSION AT THE TOP
- POSITIVE (+ve) = TENSION AT THE BOTTOM

#### **IV. ECCENTRICITIES**

- NEGATIVE (-ve) = ABOVE THE NEUTRAL AXIS
- POSITIVE (+ve) = BELOW THE NEUTRAL AXIS

## **B. SUMMARY OF DESIGN ACTIONS FOR BOX GIRDERS**

TABLE A1: DESIGN (FACTORED) SHEAR FORCES AND BENDING MOMENTS FOR BOX GIRDERS						
No.	SPAN COMBINATION			DESIGN SHEAR (KN)	DESIGN MOMENT (KNm)	
	L1 (m)	L2 (m)	L3 (m)		AT SPAN	AT SUPPORT
1	20.00	60.00	20.00	14,738.68	82,907.21	119,495.02
2	21.00	58.00	21.00	13,859.98	99,917.24	95,496.48
3	22.00	56.00	22.00	13,021.73	86,643.77	94,626.60
4	23.00	54.00	23.00	12,221.16	73,254.57	88,167.48
5	24.00	52.00	24.00	11,457.67	66,236.87	79,680.93
6	25.00	50.00	25.00	10,729.83	59,928.98	72,099.60
7	26.00	48.00	26.00	10,106.12	54,564.82	65,812.33
8	27.00	46.00	27.00	9,504.62	49,077.56	60,212.68
9	28.00	44.00	28.00	8,926.01	43,590.51	55,261.25
10	29.00	42.00	29.00	8,426.65	38,805.70	51,314.49
11	30.00	40.00	30.00	7,939.94	34,257.21	47,888.65
12	32.00	36.00	32.00	8,934.14	39,476.50	51,013.34
13	31.00	38.00	31.00	7,544.66	31,148.45	44,996.13
14	31.00	39.00	30.00	7,722.85	31,957.31	46,775.87
15	33.00	32.00	35.00	7,929.17	40,130.88	43,877.37
16	33.00	34.00	33.00	7,479.55	35,193.66	41,521.63
17	33.00	33.00	34.00	7,674.59	37,544.09	42,496.94
18	33.00	35.00	32.00	7,580.29	35,098.37	43,137.80
19	33.00	36.00	31.00	7,587.37	34,190.75	43,988.76
20	33.33	33.33	33.33	7,739.76	36,037.16	41,358.57
21	34.00	32.00	34.00	7,628.47	37,750.79	41,225.72
22	34.00	34.00	32.00	7,659.67	36,682.10	43,130.81
23	34.00	35.00	31.00	7,711.18	36,279.39	44,402.61
24	34.00	36.00	30.00	7,961.41	37,484.80	47,465.41
25	35.00	30.00	35.00	7,836.32	40,444.84	41,543.33
26	35.00	33.00	32.00	8,002.73	40,079.73	45,279.45
27	35.00	34.00	31.00	8,088.51	40,069.12	46,773.42
28	35.00	35.00	30.00	8,176.74	40,047.00	48,393.43
29	35.00	36.00	29.00	8,267.15	40,014.29	50,054.42
30	36.00	28.00	36.00	8,075.29	43,238.26	42,409.47
31	36.00	30.00	34.00	8,835.93	46,498.34	48,145.03
32	36.00	32.00	32.00	8,253.81	42,773.18	46,738.01
33	36.00	33.00	31.00	8,339.38	42,814.19	48,188.08
34	36.00	34.00	30.00	9,166.99	46,377.33	54,166.42
35	36.00	35.00	29.00	8,517.32	42,857.76	51,288.29
36	36.00	36.00	28.00	8,609.72	42,870.97	52,942.16
37	37.00	26.00	37.00	8,357.58	45,966.74	43,945.71
38	38.00	24.00	38.00	8,656.42	48,818.28	45,997.54
39	39.00	22.00	39.00	9,095.18	52,396.61	49,301.78
40	40.00	20.00	40.00	8,968.85	55,631.42	52,972.90

### **C. SUMMARY OF DESIGN ACTIONS FOR T-GIRDERS**

TABLE A2: DESIGN (FACTORED) SHEAR FORCES AND BENDING MOMENTS FOR T-GIRDERS						
No.	SPAN COMBINATION			DESIGN SHEAR (KN)	DESIGN MOMENT (KNm)	
	L1 (m)	L2 (m)	L3 (m)		AT SPAN	AT SUPPORT
1	20.00	60.00	20.00	15,632.44	100,975.04	127,077.51
2	21.00	58.00	21.00	14,260.91	92,610.14	114,707.10
3	22.00	56.00	22.00	13,773.58	86,643.77	94,626.60
4	23.00	54.00	23.00	12,908.36	73,254.57	93,356.15
5	24.00	52.00	24.00	12,083.39	69,817.07	84,235.05
6	25.00	50.00	25.00	11,297.88	63,035.93	76,093.27
7	26.00	48.00	26.00	10,550.31	56,869.77	68,837.70
8	27.00	46.00	27.00	9,837.56	50,701.00	62,418.14
9	28.00	44.00	28.00	9,568.81	46,499.06	59,423.47
10	29.00	42.00	29.00	9,024.06	41,272.52	55,120.47
11	30.00	40.00	30.00	8,425.46	35,185.90	49,482.76
12	32.00	36.00	32.00	8,738.03	37,650.15	50,225.70
13	31.00	38.00	31.00	7,779.34	31,966.08	44,996.13
14	31.00	39.00	30.00	7,965.31	32,785.01	48,326.40
15	33.00	32.00	35.00	8,206.45	41,468.11	45,427.15
16	33.00	34.00	33.00	7,708.16	36,180.95	42,808.44
17	33.00	33.00	34.00	7,940.10	38,759.77	43,982.47
18	33.00	35.00	32.00	7,728.50	36,085.71	44,503.03
19	33.00	36.00	31.00	7,682.57	35,287.58	45,598.13
20	33.33	33.33	33.33	7,969.64	37,058.83	42,635.55
21	34.00	32.00	34.00	7,870.86	38,891.74	42,541.30
22	34.00	34.00	32.00	7,723.11	37,756.03	44,514.70
23	34.00	35.00	31.00	7,693.65	37,357.59	45,868.45
24	34.00	36.00	30.00	7,876.47	38,585.65	49,044.96
25	35.00	30.00	35.00	8,102.76	41,780.89	42,954.03
26	35.00	33.00	32.00	8,286.72	41,421.64	46,910.17
27	35.00	34.00	31.00	8,348.69	41,272.57	48,307.82
28	35.00	35.00	30.00	8,443.66	41,254.71	50,010.23
29	35.00	36.00	29.00	8,541.22	41,226.44	51,757.91
30	36.00	28.00	36.00	8,319.94	44,536.13	43,686.96
31	36.00	30.00	34.00	8,414.79	44,334.74	45,838.89
32	36.00	32.00	32.00	8,518.59	44,087.12	48,259.90
33	36.00	33.00	31.00	8,610.84	44,136.54	49,786.58
34	36.00	34.00	30.00	8,705.63	44,172.62	51,383.15
35	36.00	35.00	29.00	8,802.98	44,195.91	53,053.50
36	36.00	36.00	28.00	8,902.61	44,215.58	54,795.71
37	37.00	26.00	37.00	8,613.22	47,386.85	45,277.85
38	38.00	24.00	38.00	8,923.49	50,358.01	47,402.67
39	39.00	22.00	39.00	9,319.34	53,727.18	50,505.69
40	40.00	20.00	40.00	9,210.32	57,096.68	54,310.17

#### **D. SUMMARY OF CROSS SECTION PROPERTIES FOR BOX GIRDERS**

TABLE A3: SUMMARY OF THE DESIGN OUTPUTS (BOX GIRDERS)									
No.	SPAN COMBINATION			h (mm)	t <sub>top</sub> (mm)	t <sub>bottom</sub> (mm)	b <sub>w</sub> (mm)	TENDON ECCENTRICITIES	
	L1 (m)	L2 (m)	L3 (m)					Span (mm)	Support (mm)
1	20.00	60.00	20.00	2,400.00	711.12	739.92	739.92	684.00	928.00
2	21.00	58.00	21.00	2,320.00	687.42	715.26	715.26	1,108.00	884.00
3	22.00	56.00	22.00	2,240.00	663.71	690.59	690.59	832.00	841.00
4	23.00	54.00	23.00	2,160.00	640.01	665.93	665.93	626.00	797.00
5	24.00	52.00	24.00	2,080.00	616.30	641.26	641.26	583.00	754.00
6	25.00	50.00	25.00	2,000.00	592.60	616.60	616.60	531.00	711.00
7	26.00	48.00	26.00	1,940.00	574.82	598.10	598.10	508.00	679.00
8	27.00	46.00	27.00	1,880.00	557.04	579.60	579.60	463.00	647.00
9	28.00	44.00	28.00	1,820.00	539.27	561.11	561.11	410.00	615.00
10	29.00	42.00	29.00	1,780.00	527.41	548.77	548.77	373.00	594.00
11	30.00	40.00	30.00	1,740.00	515.56	536.44	536.44	324.00	573.00
12	32.00	36.00	32.00	1,820.00	539.27	561.11	561.11	485.00	615.00
13	31.00	38.00	31.00	1,700.00	503.71	524.11	524.11	290.00	553.00
14	31.00	39.00	30.00	1,720.00	509.64	530.28	530.28	278.00	563.00
15	33.00	32.00	35.00	1,680.00	497.78	517.94	517.94	461.00	542.00
16	33.00	34.00	33.00	1,650.00	488.90	508.70	508.70	404.00	527.00
17	33.00	33.00	34.00	1,660.00	491.86	511.78	511.78	432.00	532.00
18	33.00	35.00	32.00	1,670.00	494.82	514.86	514.86	365.00	537.00
19	33.00	36.00	31.00	1,680.00	497.78	517.94	517.94	347.00	542.00
20	33.33	33.33	33.33	1,650.00	488.90	508.70	508.70	432.00	527.00
21	34.00	32.00	34.00	1,650.00	488.90	508.70	508.70	475.00	527.00
22	34.00	34.00	32.00	1,670.00	494.82	514.86	514.86	414.00	537.00
23	34.00	35.00	31.00	1,690.00	500.75	521.03	521.03	388.00	547.00
24	34.00	36.00	30.00	1,730.00	512.60	533.36	533.36	383.00	568.00
25	35.00	30.00	35.00	1,650.00	488.90	508.70	508.70	515.00	527.00
26	35.00	33.00	32.00	1,700.00	503.71	524.11	524.11	456.00	553.00
27	35.00	34.00	31.00	1,720.00	509.64	530.28	530.28	434.00	563.00
28	35.00	35.00	30.00	1,740.00	515.56	536.44	536.44	417.00	573.00
29	35.00	36.00	29.00	1,760.00	521.49	542.61	542.61	396.00	584.00
30	36.00	28.00	36.00	1,660.00	491.86	511.78	511.78	569.00	532.00
31	36.00	30.00	34.00	1,920.00	568.90	591.94	591.94	620.00	600.00
32	36.00	32.00	32.00	1,720.00	509.64	530.28	530.28	499.00	563.00
33	36.00	33.00	31.00	1,740.00	515.56	536.44	536.44	482.00	573.00
34	36.00	34.00	30.00	2,000.00	592.60	616.60	616.60	610.00	680.00
35	36.00	35.00	29.00	1,780.00	527.41	548.77	548.77	452.00	594.00
36	36.00	36.00	28.00	1,800.00	533.34	554.94	554.94	431.00	605.00
37	37.00	26.00	37.00	1,680.00	497.78	517.94	517.94	605.00	542.00
38	38.00	24.00	38.00	1,700.00	503.71	524.11	524.11	624.00	553.00
39	39.00	22.00	39.00	1,760.00	521.49	542.61	542.61	713.00	584.00
40	40.00	20.00	40.00	1,800.00	533.34	554.94	554.94	718.00	605.00

## **E. SUMMARY OF CROSS SECTION PROPERTIES FOR T-GIRDERS**



TABLE A4: SUMMARY OF THE DESIGN OUTPUTS (T-GIRDERS)								
No.	SPAN COMBINATION			h (mm)	t <sub>top</sub> (mm)	b <sub>w</sub> (mm)	TENDON ECCENTRICITIES	
	L1 (m)	L2 (m)	L3 (m)				Span (mm)	Support (mm)
1	20.00	60.00	20.00	2,400.00	600.00	1,392.00	676.00	933.00
2	21.00	58.00	21.00	2,320.00	580.00	1,345.60	662.00	889.00
3	22.00	56.00	22.00	2,240.00	560.00	1,299.20	790.00	845.00
4	23.00	54.00	23.00	2,160.00	540.00	1,252.80	622.00	801.00
5	24.00	52.00	24.00	2,080.00	520.00	1,206.40	578.00	758.00
6	25.00	50.00	25.00	2,000.00	500.00	1,160.00	540.00	715.00
7	26.00	48.00	26.00	1,920.00	480.00	1,113.60	486.00	679.00
8	27.00	46.00	27.00	1,840.00	460.00	1,067.20	423.00	630.00
9	28.00	44.00	28.00	1,880.00	470.00	1,090.40	452.00	548.00
10	29.00	42.00	29.00	1,840.00	460.00	1,067.20	411.00	528.00
11	30.00	40.00	30.00	1,700.00	425.00	986.00	291.00	556.00
12	32.00	36.00	32.00	1,720.00	430.00	997.60	333.00	567.00
13	31.00	38.00	31.00	1,660.00	415.00	962.80	259.00	535.00
14	31.00	39.00	30.00	1,680.00	420.00	974.40	251.00	546.00
15	33.00	32.00	35.00	1,650.00	412.50	957.00	432.00	530.00
16	33.00	34.00	33.00	1,610.00	402.50	933.80	359.00	510.00
17	33.00	33.00	34.00	1,630.00	407.50	945.40	397.00	520.00
18	33.00	35.00	32.00	1,630.00	407.50	945.40	334.00	520.00
19	33.00	36.00	31.00	1,650.00	412.50	957.00	324.00	530.00
20	33.33	33.33	33.33	1,610.00	402.50	933.80	382.00	510.00
21	34.00	32.00	34.00	1,610.00	402.50	933.80	418.00	510.00
22	34.00	34.00	32.00	1,630.00	407.50	945.40	368.00	520.00
23	34.00	35.00	31.00	1,650.00	412.50	957.00	351.00	530.00
24	34.00	36.00	30.00	1,690.00	422.50	980.20	344.00	551.00
25	35.00	30.00	35.00	1,620.00	405.00	939.60	478.00	515.00
26	35.00	33.00	32.00	1,670.00	417.50	968.60	425.00	541.00
27	35.00	34.00	31.00	1,680.00	420.00	974.40	389.00	546.00
28	35.00	35.00	30.00	1,700.00	425.00	986.00	373.00	556.00
29	35.00	36.00	29.00	1,720.00	430.00	997.60	361.00	567.00
30	36.00	28.00	36.00	1,620.00	405.00	939.60	501.00	515.00
31	36.00	30.00	34.00	1,650.00	412.50	957.00	468.00	530.00
32	36.00	32.00	32.00	1,680.00	420.00	974.40	443.00	546.00
33	36.00	33.00	31.00	1,700.00	425.00	986.00	430.00	556.00
34	36.00	34.00	30.00	1,720.00	430.00	997.60	415.00	567.00
35	36.00	35.00	29.00	1,740.00	435.00	1,009.20	403.00	577.00
36	36.00	36.00	28.00	1,760.00	440.00	1,020.80	385.00	587.00
37	37.00	26.00	37.00	1,640.00	410.00	951.20	535.00	525.00
38	38.00	24.00	38.00	1,660.00	415.00	962.80	553.00	535.00
39	39.00	22.00	39.00	1,700.00	425.00	986.00	569.00	550.00
40	40.00	20.00	40.00	1,740.00	435.00	1,009.20	530.00	550.00

**F. COMPLETE DESIGN OF A THREE SPAN CONTINUOUS POST-TENSIONED BOX GIRDER  
RAILWAY BRIDGE**

## PRESTRESSED CONCRETE RAILWAY BRIDGES DESIGN (BOX GIRDER)

STEP 1: SELECT SPAN COMBINATION: 33.00m - 34.00m - 33.00m

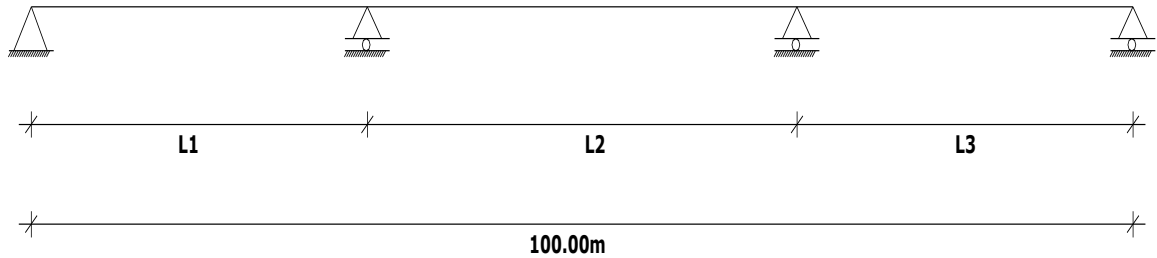

FIGURE A1: THREE SPAN BOX GIRDER CONTINUOUS BRIDGE

STEP2: DETERMINE CROSS SECTION GEOMETRY

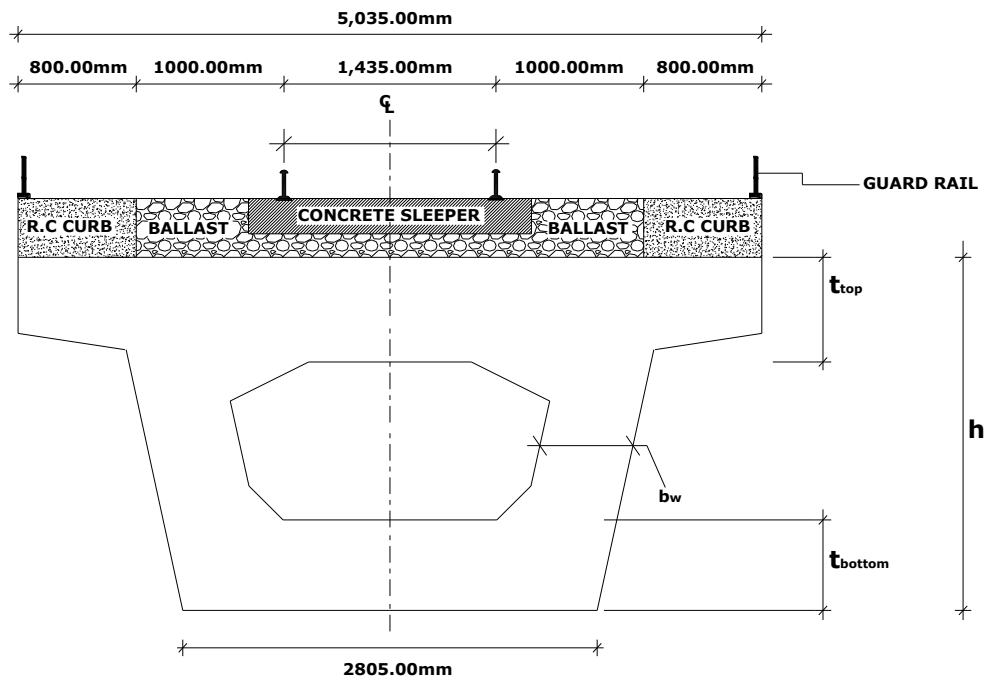

FIGURE A2: TYPICAL BOX GIRDER BRIDGE CROSS SECTION

### I. STRUCTURAL DEPTH (h):

For Prestressed Continuous Spans, the Structural depth  $d$  shall be determined as  $h = 0.04L$  (AASHTO LRFD Table 2.5.2.6.3-1.). Where,  $L$  = the span of the longest segment of the continuous structure.

We have:

SPAN L1 = 33.00m,

SPAN L2 = 34.00m,

SPAN L3 = 33.00m,

Then,  $h = 1,360.00\text{mm}$ .

After a number of trial iterations, the total depth of the structure with the given span combination, fulfilling all the design requirements is found to be:

**Use  $h = 1,650.00\text{mm}$  ( $h$  = total depth of the section)**

### II. DETERMINE THE NUMBER OF CELL BOXES (GIRDERS):

The number of cell box to be used shall be determined based on the ratio  $h/b$ , where  $h$  is the structural depth and  $b$  is the width of the top flange..... AREMA Article C-26.17.4 (c).

$h/b \geq 0.17$  ..... use single cell box,

$h/b < 0.17$  ..... use double cell box.

$h = 1,480.00\text{mm}$  ..... ( $h$  = total depth of the section)

$b = 5,035.00\text{mm}$  ..... (Refer to Chapter 5: Design Parameters and Assumptions)

**Thus,  $h/b = 0.29 > 0.17$  ..... Use single Cell Box.**

### III. WEB THICKNESS ( $b_w$ ):

The minimum web thickness is specified to be 7in. (175.00mm) ..... AREMA Article C-26.17.2.

**Take Web Thickness  $b_w = 0.3083 * h = 508.7\text{mm} > 175.00\text{mm}$**

**IV. TOP FLANGE THICKNESS ( $t_{top}$ ):**

The minimum thickness of the top slab shall be determined as  $t_{top,min} = (S_s + 3)/17$ ; where,  $S_s$  is the slab clear span in meters..... AREMA Article 2.23.11.c(1).

**Take Flange Thickness ( $t_{top}$ ) =  $0.2963 * h = 488.90\text{mm} > 280\text{mm}$**

**V. BOTTOM FLANGE THICKNESS ( $t_{bottom}$ ):**

The minimum thickness of the bottom slab shall not be less than 1/16 of the clear span between girder webs or 6 inches (150 mm)..... AREMA Article 2.23.11.c(2).

**Take Flange Thickness ( $t_{top}$ ) =  $0.2963 * h = 488.90\text{mm} > 280\text{mm}$**

**STEP 3: DETERMINE CROSS SECTION PROPERTIES**

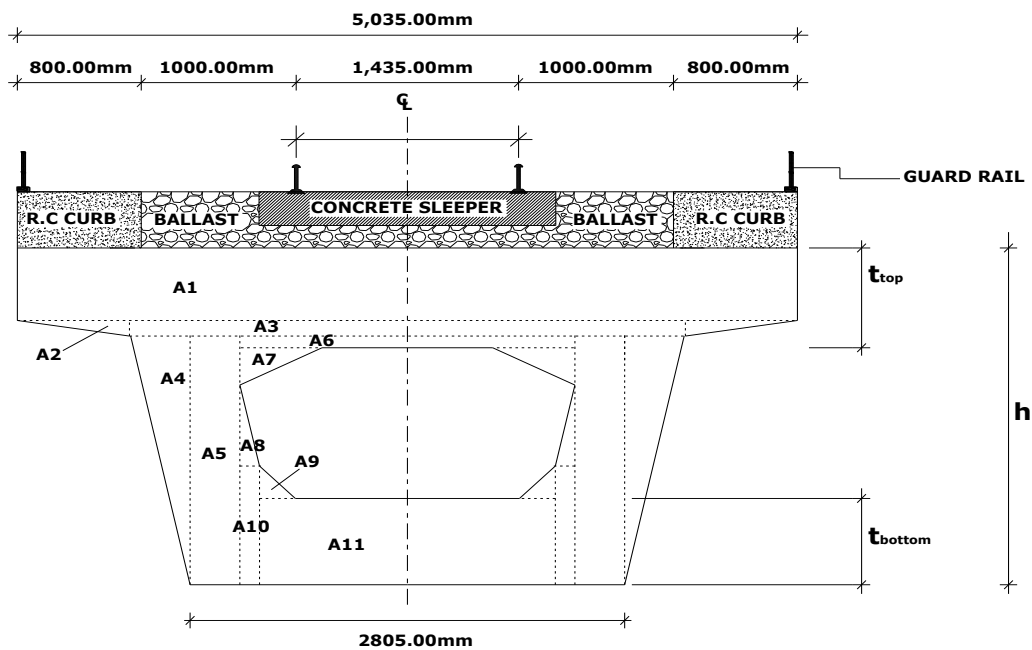

**FIGURE A3: BOX GIRDER CROSS SECTION PROPERTIES**

TABLE A5: LOCATION OF CENTROID DETERMINATION (BOX GIRDER)						
AREA	w (mm)	h (mm)	A (mm <sup>2</sup> )	y (mm)	A*y (mm <sup>3</sup> )	$\bar{y}$
A1	2,517.50	355.41	1,789,489.35	1,464.71	2,621,073,998.39	
A2	496.65	75.90	37,695.74	1,261.70	47,560,708.85	
A3	1,233.38	76.23	188,040.35	1,248.89	234,840,775.63	
A4	263.84	1,218.53	321,489.54	816.41	262,467,840.71	
A5	296.67	1,218.53	722,999.62	609.26	440,496,558.11	
A6	667.59	57.42	76,666.04	1,183.71	90,750,353.00	
A7	364.82	182.66	66,635.28	1,094.12	72,906,663.56	
A8	68.31	310.86	21,234.85	681.12	14,463,478.72	
A9	177.71	158.73	28,207.11	481.91	13,593,290.62	
A10	68.31	667.59	91,206.15	333.80	30,444,155.44	
A11	599.28	508.70	609,701.48	254.35	155,076,046.98	
			$\Sigma$		<b>3,983,673,870.02</b>	<b><u>1,007.67</u></b>

Location of Centroid measured from the bottom extreme fiber ( $\bar{y}$ ) = 1,007.67mm,

Distance from centroid to extreme top fiber of the cross section ( $y_t$ ) = 642.33mm,

Distance from centroid to extreme bottom fiber of the cross section ( $y_b$ ) = 1,007.67mm.

TABLE A6: DETERMINATION OF MOMENT OF INERTIA ABOUT THE CENTROID OF THE SECTION (BOX GIRDER)						
AREA	w (mm)	h (mm)	A (mm <sup>2</sup> )	$I_x$ (mm <sup>4</sup> )	$d_y$ (mm)	$A*d_y^2$ (mm <sup>4</sup> )
A1	2,517.50	355.41	1,789,489.35	9.42E+09	-457.04	3.74E+11
A2	496.65	75.90	37,695.74	6.03E+06	-254.03	2.43E+09
A3	1,233.38	76.23	188,040.35	4.55E+07	-241.22	1.09E+10
A4	263.84	1,218.53	321,489.54	1.33E+10	191.25	1.18E+10
A5	296.67	1,218.53	722,999.62	4.47E+10	398.40	1.15E+11
A6	667.59	57.42	76,666.04	1.05E+07	-176.04	2.38E+09
A7	364.82	182.66	66,635.28	6.18E+07	-86.45	4.98E+08
A8	68.31	310.86	21,234.85	5.70E+07	326.55	2.26E+09
A9	177.71	158.73	28,207.11	1.97E+07	525.76	7.80E+09
A10	68.31	667.59	91,206.15	1.69E+09	673.87	4.14E+10
A11	599.28	508.70	609,701.48	6.57E+09	753.32	3.46E+11
				$\Sigma$		<b>9.14E+11</b>

**Note:**  $d_y = \bar{y} - y$

Moment of Inertia about the centroid of cross section ( $I_x$ ):

$$I_x = \Sigma I_x + \Sigma A*d_y^2 = 9.90E+11\text{mm}^4$$

Section Modulus for the extreme top fiber of the cross section:

$$S_t = I_x/y_t = 1.54E+09\text{mm}^3$$

Section Modulus for the extreme bottom fiber of the cross section:

$$S_b = I_x/y_b = 9.82E+08 \text{ mm}^3.$$

#### **STEP 4: DETERMINE DESIGN VALUES FOR SHEAR AND BENDING MOMENT (LOAD FACTOR DESIGN)**

**LOAD FACTOR DESIGN:** Structures and structural members shall be designed to have design strengths at all sections at least equal to the required strengths calculated for the factored loads and forces in such combinations as stipulated in Article 2.2.4c which represent various combinations of loads and forces to which a structure may be subjected. Each part of such, structure shall be proportioned for the group loads that are applicable, and the maximum design required shall be used .....AREMA Article 2.30.1.

##### **I. GIRDER DEAD LOAD (SELF WEIGHT):**

$$\text{Unit Weight of Concrete } W_c = 25.00\text{KN/m}^3$$

$$\text{Total Cross Sectional Area } A_c = 3.95 \text{ m}^2$$

$$\text{Dead Load (Self Weight)} = (\text{Unit Weight of Concrete}) * (\text{Total Cross Sectional Area}) = 98.83\text{KN/m}.$$

##### **II. SUPER IMPOSED LOADS:**

Super Imposed Loads consist of loads from Ballast, Ties, Rails, Curbs, Hand Rails, etc.

AREMA ARTICLE 2.2.3 b(2) recommends the following materials unit weights to be used:

Track rails, inside guardrails and fastenings = 3.00KN/m,

Ballast, including track ties =  $1900 \text{ kg/m}^3 = 19.00\text{KN/m}$ ,

##### **Ballast and Track Ties**

$$\text{Area of Ballast and track ties} = 3.435 \times 0.40\text{m} = 1.34\text{m}^2$$

Super Imposed Load from Ballast and track ties = 24.51KN/m.

Concrete Curbs (on either side of the Bridge)

Unit Weight of Concrete = 25.00KN/m<sup>3</sup>

Area of Concrete Curbs = (0.80 X 0.40m) X 2= 0.64m<sup>2</sup>

Super Imposed Load from Concrete Curbs = 16.00KN/m.

### **Track Rails, Guard Rails and Fastenings**

Super Imposed Load from Rails and Fastenings = 3.00KN/m.

**Total Super Imposed Loads = 44.41KN/m.**

### **III. LIVE LOAD:**

**The recommended Live Load for Railway Structures is Cooper E 80 AREMA Article 2.2.3(d).**

Live load from a single track acting on the top surface of a structure with ballasted deck or under fills shall be assumed to have uniform lateral distribution over a width equal to the length of track tie plus the depth of ballast and fill below the bottom of tie, unless limited by the extent of the structure .....AREMA Article 2.2.3.c(3).

Length of the track tie (sleeper) = 2,200.00mm,

Depth of ballast and fill below the bottom of tie = 400.00mm,

The Live Load shall be laterally distributed over a width = 2,200 + 400 = 2,600.00mm.

The values of the actions (Shear Forces and Bending Moments) which are obtained from the Structural Analysis shall be assumed to act on a strip of width 2400.00mm. Thus, divide the values of the actions (Shear Force and Bending Moments) obtained from analysis by 2.60m for design.

### **IV. IMPACT LOAD:**

The Impact Load shall be equal to the following percentages of the Live Load:

**For  $l \leq 4m$ ,  $I = 60$ ,**



For  $4m \leq L \leq 39m$ ,  $I = (125/\sqrt{L})$ ,

For  $L > 39m$ ,  $I = 20$ .

Span (m) =                    33.00            34.00            33.00

Impact Load Factor =      0.22            0.21            0.22

**Thus, Impact Load Factor = 0.22.**

According to AREMA (2010) Article 2.2.4 C(1) Table 8-2-5, for Load Factor Design, the maximum values of the following loading combinations shall be used for design:

**GROUP I:  $1.4 (D + 5/3 (L + I) + CF + E + B + SF)$  ..... (GOVERNS)**

**GROUP IA:  $1.8 (D + L + I + CF + E + B + SF)$**

<b>TABLE A7: OUTPUTS OF THE STRUCTURAL ANALYSIS FOR EACH SEGMENT (MAXIMUM VALUES FOR BOX GIRDER)</b>				
<b>SPAN</b>	<b>LOADING</b>	<b>BENDING MOMENT (KNm)</b>		<b>SHEAR FORCE (KN)</b>
		<b>AT SPAN</b>	<b>AT SUPPORT</b>	
L1	DEAD LOAD	8,517.35	11,101.27	1,948.05
	SUPER IMPOSED LOADS	3,842.86	5,008.67	889.96
	LIVE LOAD (COOPER E-80)	6,296.72	6,676.28	1,222.11
<b>FACTORED DESIGN VALUES FOR SPAN L1</b>		<b>35,193.66</b>	<b>41,521.63</b>	<b>7,445.31</b>
L2	DEAD LOAD	3,187.07	11,101.27	1,664.78
	SUPER IMPOSED LOADS	1,456.00	5,008.67	760.55
	LIVE LOAD (COOPER E-80)	5,008.65	6,676.28	1,175.98
<b>FACTORED DESIGN VALUES FOR SPAN L2</b>		<b>20,730.18</b>	<b>41,521.63</b>	<b>6,736.50</b>
L3	DEAD LOAD	8,517.35	11,101.27	1,948.05
	SUPER IMPOSED LOADS	3,842.86	5,008.67	889.96
	LIVE LOAD (COOPER E-80)	6,296.72	6,676.28	1,222.11
<b>FACTORED DESIGN VALUES FOR SPAN L3</b>		<b>35,193.66</b>	<b>41,521.63</b>	<b>7,445.31</b>
<b>Note: Structural Analysis results using Computer Program SAP2000 (Version 14) are used.</b>				

**MAXIMUM VALUES FOR DESIGN:**

TOTAL FACTORED SHEAR FORCE (KN) = 7,445.31KN,

TOTAL FACTORED (+VE) BENDING MOMENT (KNm) = 35,193.66KNm,

TOTAL FACTORED (-VE) BENDING MOMENT (KNm) = 41,521.63KNm,

**STEP 5: DETERMINE PERMISSIBLE STRESSES**

**I. PRESTRESSING TENDONS:**

Tensile Stress in Post-Tensioning shall not exceed  $0.82f_y$  or  $0.70f'_s$  whichever is larger, but not greater than  $0.70f'_s$  at end anchorage..... AREMA Article 17.16.1.2(a).

$f_y$  = Yield Strength of Tendons = 1,670.00MPa..... $0.82f_y = 1,369.40$ MPa

$f'_s$  = Ultimate Strength of Tendons = 1,860.00MPa..... $0.70f'_s = 1,302.00$ MPa

Thus,

TENDON ALLOWABLE TENSILE STRESS = 1,369.40MPa,

TENDON ALLOWABLE TENSILE STRESS = 1,302.00MPa (At End Anchorage).

**II. CONCRETE:**

**a.) ALLOWABLE STRESSES IN CONCRETE AT TRANSFER**

Compressive Stresses in Concrete immediately after prestress transfer (before time-dependent prestress losses-Creep and Shrinkage) for, Post-tensioned members, shall not exceed  $0.55f'_c$ . .....AREMA Article 17.16.2.1(a).

Compressive Strength of Concrete,  $f'_c = 40.00$ MPa,

ALLOWABLE COMPRESSIVE STRENGTH = 22.00MPa.

Tensile Stresses in Concrete immediately after prestress transfer (before time-dependent prestress losses-Creep and Shrinkage) for Post-tensioned members, shall not exceed  $0.623(f'_{ci})^{1/2}$  for members with bonded auxiliary reinforcement with the assumption of uncracked section.....AREMA Article 17.16.2.1(b).

$f'_{ci}$  = Compressive Strength of Concrete at time of initial prestress = 36.00MPa,

ALLOWABLE TENSILE STRENGTH = 3.74MPa.

**b.) ALLOWABLE STRESSES IN CONCRETE AT SERVICE LOADS**

Compressive Stresses in Concrete at service loads (after allowance for all prestress losses) shall not exceed  $0.40f'_c$ .....AREMA Article 17.16.2.2.

ALLOWABLE COMPRESSIVE STRENGTH = 16.00MPa.

Tensile Stresses in Concrete at service loads (after allowance for all prestress losses) shall not exceed 0.00.....AREMA Article 17.16.2.2.

ALLOWABLE TENSILE STRENGTH = 0.00MPa.

**STEP 6: DETERMINE THE CABLE PATH (LAYOUT)**

It is a general principle that the maximum eccentricity of prestressing tendons should occur at locations of maximum moments. Maximum eccentricities should occur at points of maximum dead load moments and almost no eccentricity should be present at the jacked end section.

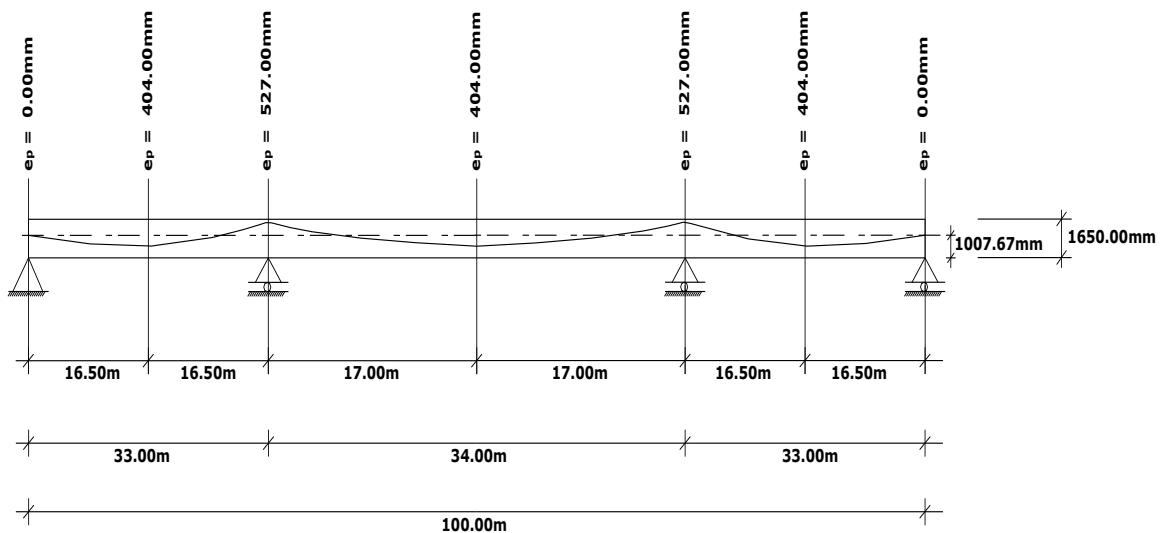

FIGURE A4: PRESTRESSING TENDON LAYOUT (BOX GIRDER)

**STEP 7: DETERMINE THE REQUIRED PRESTRESSING FORCE**

**I. AT SPAN**

Maximum Eccentricity = 404.00mm

Bottom Tensile Stress due to Applied Loads is given as:  $f_b = (M_g + M_{SDL} + M_{LL+I})/S_b$

Where,

$f_b$  = Concrete Stress at the bottom fiber

$M_g$  = Unfactored Bending Moment due to Self Weight

$M_{SDL}$  = Unfactored Bending Moment due to Super Imposed Dead Load

$M_{LL+I}$  = Unfactored Bending Moment due to Live Load Plus Impact

$S_b$  = Section Modulus for the Extreme Bottom Fiber

Thus,

$$M_g = 8,517.35\text{KNm} = 8.52\text{E}+09\text{Nmm}$$

$$M_{SDL} = 3,842.86\text{KNm} = 3.84\text{E}+09\text{Nmm}$$

$$M_{LL+I} = 7,666.87\text{KNm} = 7.67\text{E}+09\text{Nmm}$$

$$S_b = 9.82\text{E}+08\text{mm}^3$$

$$f_b = 20.39\text{N/mm}^2 = 20.39\text{MPa}.$$

Since the allowable concrete tensile stress in bottom fiber at service load is zero, the required pre-compression shall be equivalent to the tensile stress due to the applied loads  $f_b$ .

**Thus, the required pre-compression = 20.39MPa.**

**Bottom Fiber Stress due to Prestress after Losses =  $f_b = P_{se}/A + P_{se} * e_p / S_b$**

Where,

$f_b$  = Concrete Stress at the Bottom Fiber due to Prestressing

$P_{se}$  = Effective Prestressing Force after allowing for all losses

$A$  = Cross Sectional Area

$e_p$  = Strands Eccentricity

$S_b$  = Section Modulus for the Extreme Bottom Fiber

We have:

$$f_b = 20.39\text{MPa},$$

$$A = 3.95\text{E}+06\text{mm}^2,$$

$$e_p = 404.00\text{mm},$$

$$S_b = 9.82\text{E}+08\text{mm}^3,$$

Solving for  $P_{se}$  from the relationship  $f_b = P_{se}/A + P_{se} * e_p / S_b$  gives

**$P_{se} = 30,693.17\text{KN}$  (the required effective prestressing force after all losses at span).**

## II. AT SUPPORT

Maximum Eccentricity = 527.00mm

Top Fiber Tensile Stress due to Applied Loads is given as:  $f_t = (M_g + M_{SDL} + M_{LL+I})/S_t$

Where,

$f_t$  = Concrete Stress at the top fiber

$M_g$  = Unfactored Bending Moment due to Self Weight

$M_{SDL}$  = Unfactored Bending Moment due to Super Imposed Dead Load

$M_{LL+I}$  = Unfactored Bending Moment due to Live Load Plus Impact

$S_t$  = Section Modulus for the Extreme Top Fiber

Thus,

$$M_g = 11,101.27\text{KNm} = 11.1\text{E}+10\text{Nmm}$$

$$M_{SDL} = 5,008.67\text{KNm} = 5.01\text{E}+09\text{Nmm}$$

$$M_{LL+I} = 8,129.02\text{KNm} = 8.12\text{E}+09\text{Nmm}$$

$$S_t = 1.54\text{E}+09\text{mm}^3$$

$$f_t = 15.73\text{N/mm}^2 = 15.73\text{MPa}.$$

Since the allowable concrete tensile stress in top fiber at service load is zero, the required pre-compression shall be equivalent to the tensile stress due to the applied loads  $f_t$ .

**Thus, the required pre-compression = 15.73MPa.**

**Top Fiber Stress due to Prestress after Losses =  $f_t = P_{se}/A + P_{se} * e_p/S_t$**

Where,

$f_t$  = Concrete Stress at the Top Fiber due to Prestressing

$P_{se}$  = Effective Prestressing Force after allowing for all losses

$A$  = Cross Sectional Area

$e_p$  = Strands Eccentricity

$S_t$  = Section Modulus for the Extreme Top Fiber

We have:

$$f_t = 15.73\text{MPa},$$

$$A = 3.95\text{E}+06\text{mm}^2,$$

$$e_p = 527.00\text{mm},$$

$$S_t = 1.54\text{E}+09\text{mm}^3,$$

Solving for  $P_{se}$  from the relationship  $f_t = P_{se}/A + P_{se} * e_p/S_t$  gives

**$P_{se} = 26,437.91\text{KN}$  (the required effective prestressing force after all losses at support).**

**Thus,  $P_{se} = 30,693.17\text{KN}$  (span governs).**

Note: For Post-Tensioned members, an average of 18% prestress loss can be considered with the assumption of applying over tensioning to overcome friction and anchorage losses.

Assume Prestress Losses = 18.00%

**Prestressing Force,  $P = 36,217.94\text{KN}$ .**

#### **STEP 8: DETERMINE THE REQUIRED NUMBER OF STRANDS**

Strand Diameter = 15.24mm,

Strand Area = 140.00mm<sup>2</sup>,

Prestressing Force,  $P = 36,217.94\text{KN}$ ,

Allowable Tensile Stress = 1,302.00MPa (At End Anchorage),

Required Number of Strands = (Prestressing Force)/ (Allowable Tensile Stress \* Strand Area)

**Thus, Number of Strands = 199.**

#### **STEP 9: CHECK STRESSES IN CONCRETE (AT TRANSFER)**

##### **I. AT SPAN**

Maximum Eccentricity = 404.00mm,

**Top Fiber Stress after Losses =  $f_t = P_{se}/A - P_{se} * e_p/S_t + M_g/S_t$**

Where,

$P_{se}$  = Effective Prestressing Force after allowing for all losses = 30,693.17KN,

$A$  = Cross Sectional Area = 3,953,365.51mm<sup>2</sup>,

$e_p$  = 404.00mm,

$M_g$  = Unfactored Bending Moment due to Self Weight = 8,517.35KNm,

$S_t$  = Section Modulus for the Extreme Bottom Fiber = 1.54E+09mm<sup>3</sup>,

**Then,  $f_t = 5.24\text{MPa (Compressive)} < 22.00\text{ MPa}$  .....OK!**

**Bottom Fiber Stress after Losses =  $f_b = P_{se}/A + P_{se} * e_p / S_b - M_g / S_b$**

Where,

$P_{se}$  = Effective Prestressing Force after allowing for all losses = 30,693.17KN,

$A$  = Cross Sectional Area = 3,953,365.51mm<sup>2</sup>,

$e_p$  = 404.00mm,

$M_g$  = Unfactored Bending Moment due to Self Weight = 8,517.35KNm,

$S_b$  = Section Modulus for the Extreme Bottom Fiber =  $S_b = 9.82\text{E}+08\text{mm}^3$ ,

**Then,  $f_b = 11.72\text{MPa (Compressive)} < 22.00\text{ MPa}$  .....OK!**

## II. AT SUPPORT

Maximum Eccentricity = 527.00mm

**Top Fiber Stress after Losses =  $f_t = P_{se}/A + P_{se} * e_p / S_t - M_g / S_t$**

Where,

$P_{se}$  = Effective Prestressing Force after allowing for all losses = 30,693.17KN,

$A$  = Cross Sectional Area = 3,953,365.51mm<sup>2</sup>,

$e_p$  = 404.00mm,

$M_g$  = Unfactored Bending Moment due to Self Weight = 11,101.27KNm,

$S_t$  = Section Modulus for the Extreme Bottom Fiber = 1.54E+09mm<sup>3</sup>,

**Then,  $f_t = 11.06\text{MPa (Compressive)} < 22.00\text{ MPa}$  .....OK!**

**Bottom Fiber Stress after Losses =  $f_b = P_{se}/A - P_{se} * e_p / S_b + M_g / S_b$**

Where,

$P_{se}$  = Effective Prestressing Force after allowing for all losses = 30,693.17KN,

A = Cross Sectional Area = 3,953,365.51mm<sup>2</sup>,

e<sub>p</sub> = 404.00mm,

M<sub>g</sub> = Unfactored Bending Moment due to Self Weight = 11,101.27KNm,

S<sub>b</sub> = Section Modulus for the Extreme Bottom Fiber = S<sub>b</sub> = 9.82E+08mm<sup>3</sup>,

**Then, f<sub>b</sub> = 2.60MPa (Compressive) < 22.00 MPa .....OK!**

### STEP 10: CHECK STRESSES IN CONCRETE AT END ANCHORAGES (AT TRANSFER)

Maximum Eccentricity = 0.00mm

**Bottom Fiber Stress after Losses = f<sub>b</sub> = P<sub>se</sub>/A + P<sub>se</sub>\*e<sub>p</sub>/S<sub>b</sub> - M<sub>g</sub>/S<sub>b</sub>**

Where,

P<sub>se</sub> = Effective Prestressing Force after allowing for all losses = 30,693.17KN,

A = Cross Sectional Area = 3,953,365.51mm<sup>2</sup>,

e<sub>p</sub> = 0.00mm,

M<sub>g</sub> = Unfactored Bending Moment due to Self Weight = 0.00KNm,

S<sub>b</sub> = Section Modulus for the Extreme Bottom Fiber = S<sub>b</sub> = 9.82E+08mm<sup>3</sup>,

**Then, f<sub>b</sub> = 7.76MPa (Compressive) < 22.00 MPa .....OK!**

**Top Fiber Stress after Losses = f<sub>t</sub> = P<sub>se</sub>/A - P<sub>se</sub>\*e<sub>p</sub>/S<sub>t</sub> + M<sub>g</sub>/S<sub>t</sub>**

Where,

P<sub>se</sub> = Effective Prestressing Force after allowing for all losses = 30,693.17KN,

A = Cross Sectional Area = 3,953,365.51mm<sup>2</sup>,

e<sub>p</sub> = 0.00mm,

M<sub>g</sub> = Unfactored Bending Moment due to Self Weight = 0.00KNm,

S<sub>t</sub> = Section Modulus for the Extreme Bottom Fiber = 1.54E+09mm<sup>3</sup>,

**Then, f<sub>t</sub> = 7.76MPa (Compressive) < 22.00 MPa .....OK!**

### STEP 11: CHECK STRESSES IN CONCRETE (AT SERVICE LOADS)

#### I. AT SPAN

Maximum Eccentricity = 404.00mm



**Top Fiber Stress after Losses =  $f_t = P_{se}/A - P_{se} * e_p/S_t + (M_g + M_{SDL} + M_{LL+I})/S_t$**

Where,

$P_{se}$  = Effective Prestressing Force after allowing for all losses = 30,693.17KN,

$A$  = Cross Sectional Area = 3,953,365.51mm<sup>2</sup>,

$e_p$  = 404.00mm,

$M_g$  = Unfactored Bending Moment due to Self Weight = 8,517.35KNm,

$M_{SDL}$  = Unfactored Bending Moment Super Imposed Dead Load = 3,842.86KNm,

$M_{LL+I}$  = Unfactored Bending Moment due to Live Load + Impact = 7,666.87KNm,

$S_t$  = Section Modulus for the Extreme Bottom Fiber = 1.54E+09mm<sup>3</sup>,

**Then,  $f_t = 12.71\text{MPa (Compressive)} < 16.00 \text{ MPa} \dots\dots\dots\text{OK!}$**

**Bottom Fiber Stress after Losses =  $f_b = P_{se}/A + P_{se} * e_p/S_b - (M_g + M_{SDL} + M_{LL+I})/S_b$**

Where,

$P_{se}$  = Effective Prestressing Force after allowing for all losses = 30,693.17KN,

$A$  = Cross Sectional Area = 3,953,365.51mm<sup>2</sup>,

$e_p$  = 404.00mm,

$M_g$  = Unfactored Bending Moment due to Self Weight = 8,517.35KNm,

$M_{SDL}$  = Unfactored Bending Moment Super Imposed Dead Load = 3,842.86KNm,

$M_{LL+I}$  = Unfactored Bending Moment due to Live Load + Impact = 7,666.87KNm,

$S_b$  = Section Modulus for the Extreme Bottom Fiber =  $S_b = 9.82\text{E}+08\text{mm}^3$ ,

**Then,  $f_b = 0.00\text{MPa (Tension)} < 0.00 \text{ MPa} \dots\dots\dots\text{OK!}$**

**II. AT SUPPORT**

Maximum Eccentricity = 527.00mm

**Top Fiber Stress after Losses =  $f_t = P_{se}/A + P_{se} * e_p/S_t - (M_g + M_{SDL} + M_{LL+I})/S_t$**

Where,

$P_{se}$  = Effective Prestressing Force after allowing for all losses = 30,693.17KN,

$A$  = Cross Sectional Area = 3,953,365.51mm<sup>2</sup>,

$$e_p = 527.00\text{mm},$$

$$M_g = \text{Unfactored Bending Moment due to Self Weight} = 11,101.27\text{KNm},$$

$$M_{SDL} = \text{Unfactored Bending Moment Super Imposed Dead Load} = 5,008.67\text{KNm},$$

$$M_{LL+I} = \text{Unfactored Bending Moment due to Live Load + Impact} = 8,129.02\text{KNm},$$

$$S_t = \text{Section Modulus for the Extreme Bottom Fiber} = 1.54\text{E}+09\text{mm}^3,$$

**Then,  $f_t = 2.53\text{MPa (Compressive)} < 16.00\text{ MPa}$  .....OK!**

$$\text{Bottom Fiber Stress after Losses} = f_b = P_{se}/A - P_{se} * e_p / S_b + (M_g + M_{SDL} + M_{LL+I}) / S_b$$

Where,

$$P_{se} = \text{Effective Prestressing Force after allowing for all losses} = 30,693.17\text{KN},$$

$$A = \text{Cross Sectional Area} = 3,953,365.51\text{mm}^2,$$

$$e_p = 527.00\text{mm},$$

$$M_g = \text{Unfactored Bending Moment due to Self Weight} = 11,101.27\text{KNm},$$

$$M_{SDL} = \text{Unfactored Bending Moment Super Imposed Dead Load} = 5,008.67\text{KNm},$$

$$M_{LL+I} = \text{Unfactored Bending Moment due to Live Load + Impact} = 8,129.02\text{KNm},$$

$$S_b = \text{Section Modulus for the Extreme Bottom Fiber} = S_b = 9.82\text{E}+08\text{mm}^3,$$

**Then,  $f_b = 15.97\text{MPa (Compressive)} < 16.00\text{ MPa}$  .....OK!**

### **STEP 12: CHECK STRESSES IN CONCRETE AT END ANCHORAGES (AT SERVICE LOADS)**

The Prestressing Force is at its maximum value at release, and Service Loads do not affect Stresses at the end of the structure. Thus, Stresses at release will govern at the end of the Structure and there is no need to check Stresses at the end at Service Loads.

### **STEP 13: DETERMINE SECONDARY MOMENTS DUE TO THE APPLICATION OF THE PRESTRESSING FORCE**

In addition to the primary moments ( $P * e_p$ ), secondary moments ( $M_{sec.}$ ) are introduced in continuous structures as the prestressing is applied. Secondary moments develop in a prestressed member due to prestressing forces, and as a consequence of the constraint provided by the supports to the free movement of the prestressed member. If a prestressed member is allowed to displace freely, as in the case of determinate structures

or precast members prior to alignment and installation, no secondary moments are generated. However, in most cast-in-place construction, where supports constrain movement of the prestressed member, secondary actions can be significant and therefore must be accounted for in the design. Secondary effects are typically not, however, included in the service stress analysis.

Assume a Parabolic Tendon Profile for the Structure as shown below:

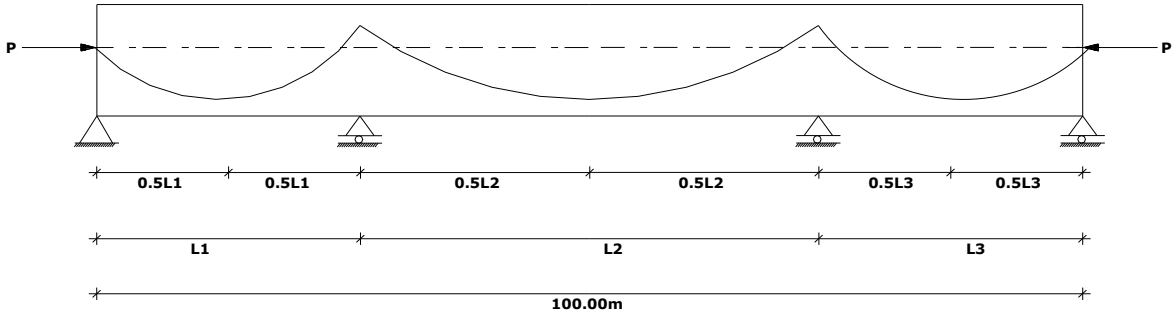

FIGURE A5: TENDON PROFILE (BOX GIRDER)

Then, the equivalent upward tendon load exerted on the structure can be determined as  $w_t = (8 \cdot P \cdot e_p) / L^2$ .

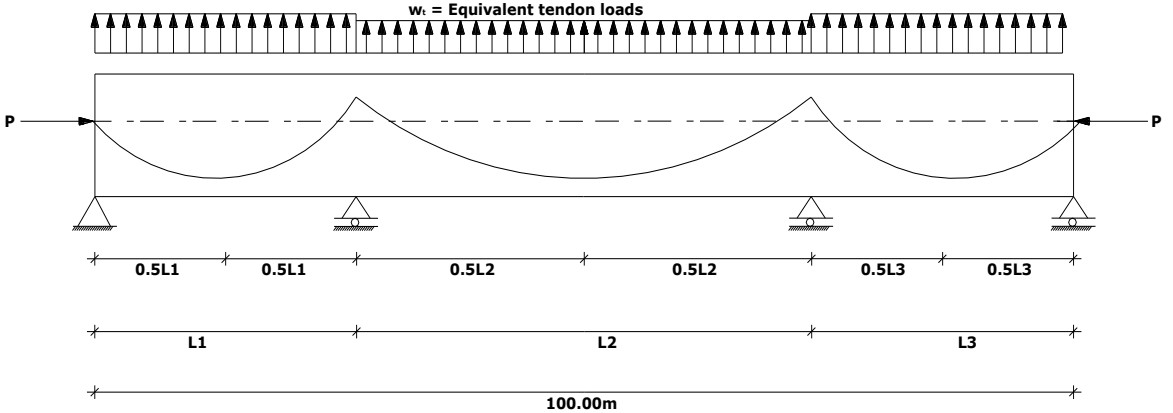

FIGURE A6: EQUIVALENT LOAD FOR PARABOLIC TENDON PROFILE (BOX GIRDER)

The equivalent tendon load  $w_t$  will be:

$e_p = 404.00\text{mm}$  (at span),

$P_{se} = 30,693.17\text{KN}$ ,

$L_1 = 33.00\text{m}$ ,

$L_2 = 34.00\text{m}$ ,

$L_3 = 33.00\text{m}$ ,

Then,

$w_{t1} = 91.09\text{KN/m}$  (for span 1)

$w_{t2} = 85.81\text{KN/m}$  (for span 2)

$w_{t3} = 91.09\text{KN/m}$  (for span 3)

Now, we will determine the reactions induced to restrain the upward movement of the beam at interior supports and the moments under the action of the equivalent tendon loads.

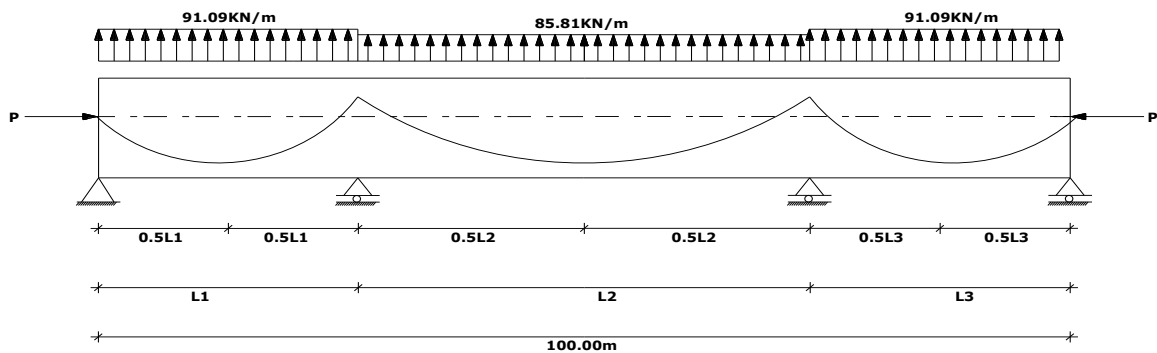

FIGURE A7: TENDON LOADS ACTING ON THE STRUCTURE (BOX GIRDER)

Run structural analysis under the action of equivalent tendon loads:

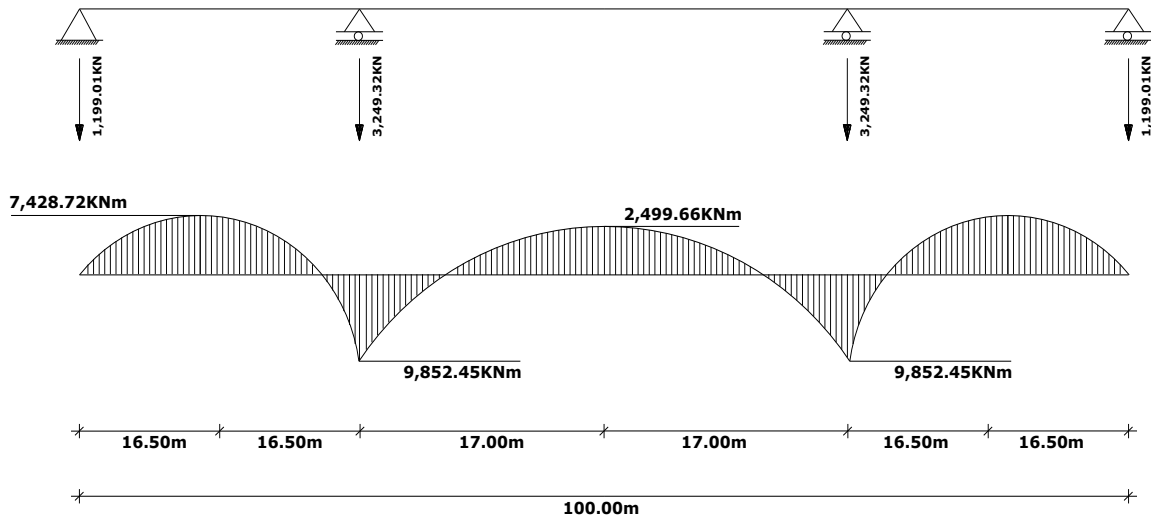

FIGURE A8: REACTIONS INDUCED UNDER THE ACTION OF THE PRESTRESSING FORCE  
(BOX GIRDER)

Then, the balanced load moment is the moment under the action of the external which shall be counter acted by the action of the applied prestressing force. the external loading shall be equal to the equivalent tendon load, but opposite in direction. Thus, the balanced moment diagram will be equal to the moment under the action of the equivalent tendon loads but opposite in direction.

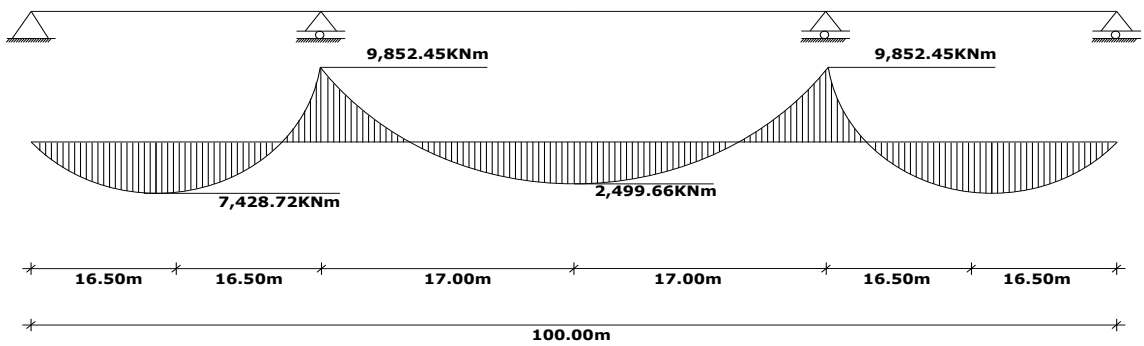

FIGURE A9: BALANCED MOMENT DIAGRAM (BOX GIRDER)

Thus,

$$M_{\text{balanced}} = 7,917.76\text{kNm (at L1 mid-span),}$$

$$M_{\text{balanced}} = -9,852.45\text{kNm (at the first interior support),}$$

$M_{\text{balanced}} = 2,499.66\text{KNm}$  (at L2 mid-span),

$M_{\text{balanced}} = -9,852.45\text{KNm}$  (at the second interior support),

$M_{\text{balanced}} = 7,917.76\text{KNm}$  (at L3 mid-span).

In order to determine the secondary moments, we need to estimate the primary moment  $M_1$  which is due to the eccentricity of the tendon profile with respect to the neutral axis:

$$M_1 = P_{se} * e_p$$

$e_p = 404.00\text{mm}$  (at span),

$e_p = -527.00\text{mm}$  (at support),

$P_{se} = 30,693.17\text{KN}$ ,

Then,

$M_1 = 12,400.04\text{KNm}$  (at L1 mid-span),

$M_1 = -16,175.30\text{KNm}$  (at the first interior support),

$M_1 = 12,400.04\text{KNm}$  (at L2 mid-span),

$M_1 = -16,175.30\text{KNm}$  (at the second interior support),

$M_1 = 12,400.04\text{KNm}$  (at L3 mid-span).

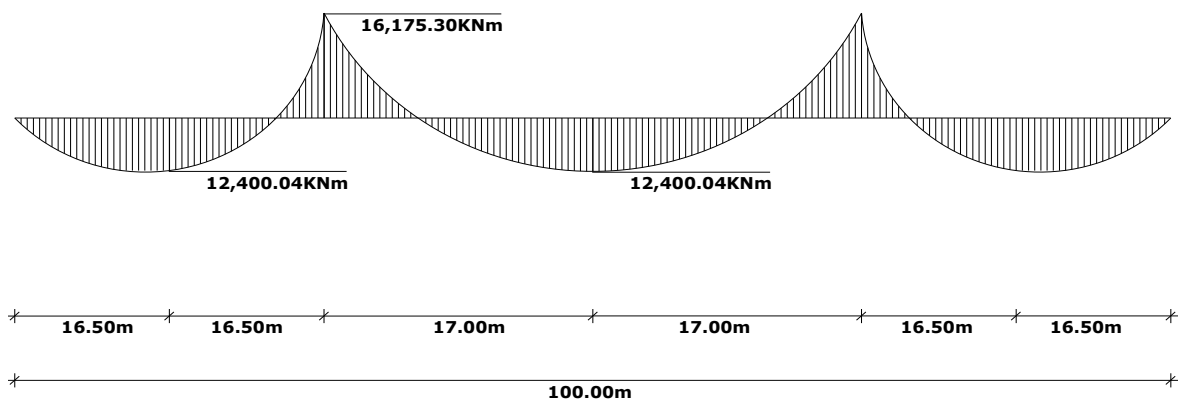

FIGURE A10: PRIMARY MOMENT DIAGRAM (BOX GIRDER)

Then, the secondary moment  $M_{\text{sec}}$  can be determined as  $M_{\text{sec}} = M_{\text{balanced}} - M_1$ :

$M_1 = -4,482.28\text{KNm}$  (at L1 mid-span),

$M_{\text{sec.}} = 6,322.85\text{KNm}$  (at the first interior support),

$M_{\text{sec.}} = -9,900.38\text{KNm}$  (at L2 mid-span),

$M_{\text{sec.}} = 6,322.85\text{KNm}$  (at the second interior support),

$M_{\text{sec.}} = -4,482.28\text{KNm}$  (at L3 mid-span).

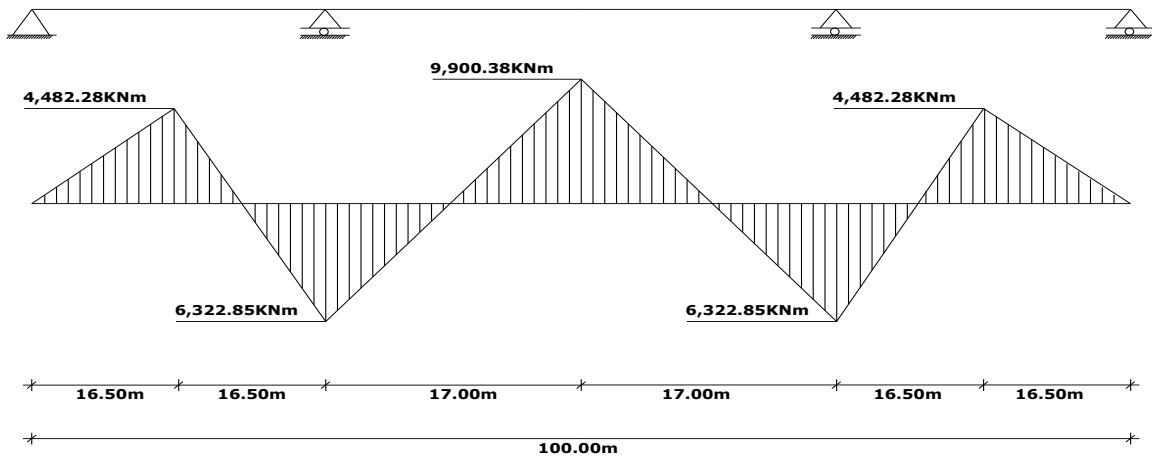

FIGURE A11: SECONDARY MOMENT DIAGRAM (BOX GIRDER)

For design purpose, we will use the secondary moment which shall have the most extreme effect on the structure:

$M_1 = -4,482.28\text{KNm}$  (At span: tension at the top),

$M_{\text{sec.}} = 6,322.85\text{KNm}$  (At support: tension at the bottom).

Now, we will add the secondary moments obtained here to the dead load moments, superimposed load moment, live load + impact moments and check the ultimate strength of the section. Note that secondary moment is not factored because, in most cases, it counteracts the moments due to dead and live loading.

FACTORED SPAN (+VE) BENDING MOMENT (KNm) = 35,193.66KNm,

FACTORED SUPPORT (-VE) BENDING MOMENT (KNm) = -41,521.63KNm,

SECONDARY MOMENT AT SPAN (KNm) = -4,482.28KNm,

SECONDARY MOMENT AT SUPPORT (KNm) = 6,322.85KNm,

**TOTAL DESIGN (+VE) BENDING MOMENT AT SPAN (KNm) = 30,711.38KNm,**

**TOTAL DESIGN (-VE) BENDING MOMENT AT SUPPORT (KNm) = -35,198.78KNm.**

#### STEP 14: CHECK THE ULTIMATE FLEXURAL STRENGTH OF THE SECTION

##### I. AT SPAN

For rectangular or flanged sections with non-prestressed tension reinforcement included, in which the depth of the equivalent rectangular stress block, defined as  $(A_s^* f_{su}^* + A_s f_{sy}) / (0.85 f'_c b)$ , is not greater than the compression flange thickness "t", the design flexural strength shall be assumed as:

$$\phi M_n = \phi \{ A_s^* f_{su}^* d [1 - 0.6 \{ (p^* f_{su}^* / f'_c) + (d_t / d) (p f_{sy} / f'_c) \}] + A_s f_{sy} d_t [1 - 0.6 \{ (d / d_t) (p^* f_{su}^* / f'_c) + (p f_{sy} / f'_c) \}] \} \dots \dots \dots \text{AREMA Article 17.18.2}$$

Where,

$\phi$  = Strength Reduction Factor (AREMA Article 17.15.1.b (1) = 0.95,

$A_s^*$  = Area of Prestressing Steel = 27,817.16mm<sup>2</sup>,

$f_{su}^*$  = Average Stress in Prestressing Steel at Ultimate Load = 1,369.40MPa,

$d$  = Distance from extreme compression fiber to centroid of the Prestressing Force =  $h - (\bar{y} - e_p) = 1,046.33\text{mm}$ ,

$d_t$  = Distance from the extreme compressive fiber to the centroid of the non-prestressed tension reinforcement (assume) = 2,400.00,

$p^*$  =  $A_s^* / (bd^*)$ , ratio of prestressing steel = 0.0053,

$p$  =  $A_s / (bd)$  ratio of non-prestressed tension reinforcements = 0.0002,

$A_s$  = Area of Non-Prestressing Steel (provide 6 diameter 24 bars) = 2,712.96mm<sup>2</sup>,

$b$  = width of flange or width of rectangular member = 5,035.00mm,

$f'_c$  = Compressive Strength of Concrete at 28 days = 40.00MPa,

$f_{sy}$  = Yield Strength of non-prestressed conventional reinforcement in tension = 347.83MPa.



Check  $(A_s^* f_{su}^*) / (0.85 f_c' b)$  is not greater than the compression flange thickness " $t_{top}$ ":

$$(A_s^* f_{su}^*) / (0.85 f_c' b) = 222.52 \text{mm} < t_{top} = 488.90 \text{mm} \dots\dots\dots \text{OK!}$$

Then,

$$\phi M_n = 35,703.63 \text{KNm} > M_d = 30,711.38 \text{KNm} \dots\dots\dots \text{OK!}$$

## II. AT SUPPORT

$\phi$  = Strength Reduction Factor (AREMA Article 17.15.1.b (1)) = 0.95,

$A_s^*$  = Area of Prestressing Steel = 27,817.16mm<sup>2</sup>,

$f_{su}^*$  = Average Stress in Prestressing Steel at Ultimate Load = 1,369.40MPa,

$d$  = Distance from extreme compression fiber to centroid of the Prestressing Force =  $h - (\bar{y} - e_p)$  = 1,534.67mm,

$d_t$  = Distance from the extreme compressive fiber to the centroid of the non-prestressed tension reinforcement (assume) = 2,400.00,

$\rho^*$  =  $A_s^* / (bd^*)$ , ratio of prestressing steel = 0.0036,

$\rho$  =  $A_s / (b d_t)$  ratio of non-prestressed tension reinforcements = 0.0000,

$A_s$  = Area of Non-Prestressing Steel (provide 6 diameter 24 bars) = 0.00mm<sup>2</sup>,

$b$  = width of flange or width of rectangular member = 5,035.00mm,

$f_c'$  = Compressive Strength of Concrete at 28 days = 40.00MPa,

$f_{sy}$  = Yield Strength of non-prestressed conventional reinforcement in tension = 347.83MPa.

Check  $(A_s^* f_{su}^*) / (0.85 f_c' b)$  is not greater than the compression flange thickness " $t_{top}$ ":

$$(A_s^* f_{su}^*) / (0.85 f_c' b) = 222.52 \text{mm} < t_{top} = 488.90 \text{mm} \dots\dots\dots \text{OK!}$$

Then,

$$\phi M_n = 51,430.00 \text{KNm} > M_d = 35,198.78 \text{KNm} \dots\dots\dots \text{OK!}$$

## STEP 15: CHECK DUCTILITY LIMITS

### I. MAXIMUM PRESTRESSING STEEL

Prestressed concrete members shall be designed so that the steel is yielding as ultimate capacity is approached. In general, the reinforcement index shall be such that:

$P^*f_{su}^*/f'_c \dots \leq 0.36\beta_1$  for rectangular sections,  
 $A_{sr}f_{su}^*/b'df'_c \dots \leq 0.36\beta_1$  for flanged sections,  
 (AREMA Article 17.19.1).

Take  $\beta_1 =$  factor for concrete strength = 0.70 ..... AREMA Article 2.31.1(f).  
 Since  $(A^*f_{su}^*)/(0.85f'_cb)$  is not greater than the compression thickness “ $t_{top}$ ”, the section is rectangular.

**Thus, at span and support (Rectangular Section)  $P^*f_{su}^*/f'_c = 0.12 \leq 0.25$  .....OK!**

## II. MINIMUM REINFORCEMENT

The total amount of prestressed and non-prestressed reinforcement shall be adequate to develop an ultimate moment at the critical section at least 1.2 times the Cracking Moment,  $M^*_{cr}$ .

$$\phi M_n \geq 1.2 M^*_{cr}$$

$$\text{Where, } M^*_{cr} = (f_r + f_{pe})S_c - M_{d/nc}(S_c/S_b - 1)$$

Approximate values for  $M_{d/nc}$  and  $s_b$  shall be used for any intermediate composite sections. Where, beams are designed to be non-composite, substitute  $S_b$  for  $S_c$  in the above equation for the calculation of  $M^*_{cr}$ .

$$\text{Since the section is non-composite, } S_c = S_b \text{ so that } M^*_{cr} = (f_r + f_{pe})S_b = M_{d/nc}(S_b/S_b - 1) = (f_r + f_{pe})S_b$$

$f_{pe}$  = compressive stress in concrete due to effective prestress forces only (after allowance for all prestress losses) at extreme fiber of section where tensile stress is caused by externally applied loads.

$$f_{pe} = 15.97 \text{MPa (Maximum Compressive Stress)}$$

$f_r$  = modulus of rupture of concrete, as defined in Article 17.16.2.3 =  $0.623(f'_{ci})^{1/2}$  for normal weight concrete.

$$f_r = 11.21 \text{MPa,}$$

$$S_b = 9.82 \text{E}+08 \text{mm}^3,$$

$$M^*_{cr} = 26,707.16 \text{MPa.}$$

**The requirement is  $\phi M_n \geq 1.2M_{cr}^*$ :**

$\phi M_n$  = take the flexural strength of the section at span or at support whichever is minimum.

**$\phi M_n = 35,703.63\text{KNm} \geq 1.2M_{cr}^* = 32,048.59\text{KNm}$  ..... OK!**

**STEP 16: DESIGN FOR SHEAR**

Members subject to shear shall be designed so that

**$V_u \leq \phi(V_c + V_s)$  ..... AREMA Article 17.21.1.3.**

Where,

$\phi$  = the strength reduction factor = 0.90 for shear (AREMA Article 17.15.1.b(2)),

$V_u$  = the factored shear force at the section considered,

$V_c$  = the nominal shear strength provided by concrete,

$V_s$  = the nominal shear strength provided by web reinforcement.

**Shear Strength provided by Concrete ( $V_c$ ):**

For more precise analysis the shear strength provided by concrete,  $V_c$ , shall be taken as the lesser of the values  $V_{ci}$  or  $V_{cw}$  ..... AREMA Article 17.21.2.2.

**I. Determine  $V_{ci}$ :**

**$V_{ci} = 5 \times 104(f'_c)1/2b'd + V_d + V_i * M_{cr}/M_{max} \geq 220(f'_c b'd)^{1/2}$**

Where,

$f'_c$  = Compressive Strength of Concrete at 28 days = 40.00MPa,

$b'$  = web width = 508.70mm,

$d$  = distance from extreme compression fiber to centroid of the prestressing force = 1,534.67mm (take at support),

$V_d$  = shear force at section due to unfactored dead load =  $V_g + V_{SDL} = 2,838.01\text{KN}$ ,

$M_{cr}$  = moment causing flexural cracking at section due to externally applied loads,

$M_{max}$  = maximum factored moment at section due to externally applied loads =  $M_u - M_g -$

$M_{SDL} = 25,411.69\text{KNm}$ ,

$V_i$  = factored shear force at section due to externally applied loads occurring simultaneously with  $M_{max} = V_u - V_g - V_{SDL} = 4,607.30\text{KN}$ .

$M_{cr}$  is computed by

$$M_{cr} = (I/y_t)(0.5 \cdot f'_c)^{1/2} + f_{pe} - f_d$$

Where,

$I$  = moment of inertia about the centroid of the cross section =  $9.90\text{E}+11 \text{ mm}^4$ ,

$y_t$  = distance from centroidal axis of the section to extreme fiber in tension =  $642.33\text{mm}$ ,

$f'_c$  = Compressive Strength of Concrete at 28 days =  $40.00\text{MPa}$ ,

$f_{pe}$  = compressive stress in concrete due to effective prestress forces only =  $15.97\text{MPa}$ ,

$f_d$  = stress due to unfactored dead load =  $((M_g + M_{SDL})/S_b) = 16.40\text{MPa}$ .

Then,

$M_{cr} = 4,215.78\text{KNm}$ , and

$$V_{ci} = 5 \times 10^4 (f'_c)^{1/2} b' d + V_d + V_i \cdot M_{cr} / M_{max} \geq 220 (f'_c b' d)^{1/2}$$

$$V_{ci} = 246,875,396.71\text{KN} \geq 220 (f'_c b' d)^{1/2} = 1,229.39\text{KN} \dots\dots\dots \text{OK!}$$

**II. Determine  $V_{cw}$ :**

$$V_{cw} = 10 \times 10^5 [(0.29 (f'_c)^{1/2} + 0.3 f_{pe}) b' d] + V_p \text{ but } d \text{ need not be taken less than } 0.8h.$$

Where,

$f'_c$  = Compressive Strength of Concrete at 28 days =  $40.00\text{MPa}$ ,

$f_{pe}$  = compressive stress in concrete due to effective prestress forces only =  $15.97\text{MPa}$ ,

$b'$  = web width =  $508.70\text{mm}$ ,

$d$  = distance from extreme compression fiber to centroid of the prestressing force =  $1,534.67\text{mm}$  (take at support),

$V_p$  = vertical component of effective prestress force at section = taking the slope of the tendon at supports to be  $16^\circ = P_{se} \cdot \sin 16^\circ = 8,456.01\text{KN}$ .

**Thus,**

$$V_{cw} = 5,172,572,199.09\text{KN}.$$

**$V_c$  shall be the lesser of  $V_{ci}$  or  $V_{cw}$  ..... AREMA Article 17.21.2.2.**

Thus,  $V_c = 246,875,396.71\text{KN} > V_u = 7,445.31\text{KN}$  ..... OK!  
 Since the shear strength provided by concrete  $V_c > V_u$ , web reinforcement is not required.  
 However; minimum shear reinforcement must be provided.

**III. MINIMUM SHEAR REINFORCEMENT**

The minimum area of web reinforcement shall be  $A_v = (0.345b's)/f_{sy}$  ..... AREMA  
 Article 17.21.3.3.

Use bars = 10.00mm,

$A_v = 314.00\text{mm}^2$  (Note:  $A_v = 0.25 \cdot 3.14 \cdot (\text{diameter})^2 \cdot 4$  ..... (4 because two webs),

$f_{sy} = 347.83\text{MPa}$ ,

$b' = 508.70\text{mm}$ ,

Then,  $s = 622.32\text{mm}$ .

Provide Diameter = 10mm Closed Bars @  $S = 620.00\text{mm}$ .

$A_v = 314.00\text{mm}^2 \geq \text{Minimum } A_v = 312.83\text{mm}^2$  ..... OK!

**STEP 17: CHECK DEFLECTIONS**

Since the stress limits calculated in steps 9, 10, and 11 are within the tolerable range under the action of all the loadings considered, there is no need to check for the deflections.

**STEP 18: CHECK BEARING STRESS UNDER THE ANCHORAGE STEEL PLATE**

The effective concrete bearing compressive strength  $f_b$  used for design shall not exceed  
 $f_{br} \leq 0.7f'_{ci} (A/A_{gb})^{0.5}$  but  $f_{br} \leq 2.25f'_{ci}$  ..... AREMA Article 17.22.7.2.

Where,

$f'_{ci}$  = concrete compressive strength at the time of prestressing,

A = the maximum area of the portion of the supporting surface that is geometrically similar to the loaded area and concentric with it,

$A_{gb}$  = gross area of the bearing plate.

Notes for the Placement of the Cable Ducts:

- 1.) Ducts for multiple wire, strand, or bar tendons shall have an inside cross sectional area not less than 2 times the net area of tendons.....AREMA Article 17.5.5(c).
- 2.) Clear distance between post-tensioning ducts or trumpets at each end of a member shall not be less than 1-1/2 in. (40 mm).....AREMA Article 17.5.1(b).

We have:

$f_{ci} = 40.00\text{Mpa}$ ,

Number of Strands = 199,

Single Strand Area =  $140.00\text{mm}^2$ ,

Total Strand Area =  $27,817.16\text{mm}^2$ ,

Prestressing Force,  $P = 36,217.94\text{KN}$ .

Use ducts with inner diameter = 80.00mm and outer diameter = 85.00mm,

Inner Area of Cable Ducts =  $5,024.00\text{mm}^2$ ,

Minimum Number of Ducts = 6,

Use Cable Ducts = 6 (Distribute uniformly on both sides of the bridge cross section).

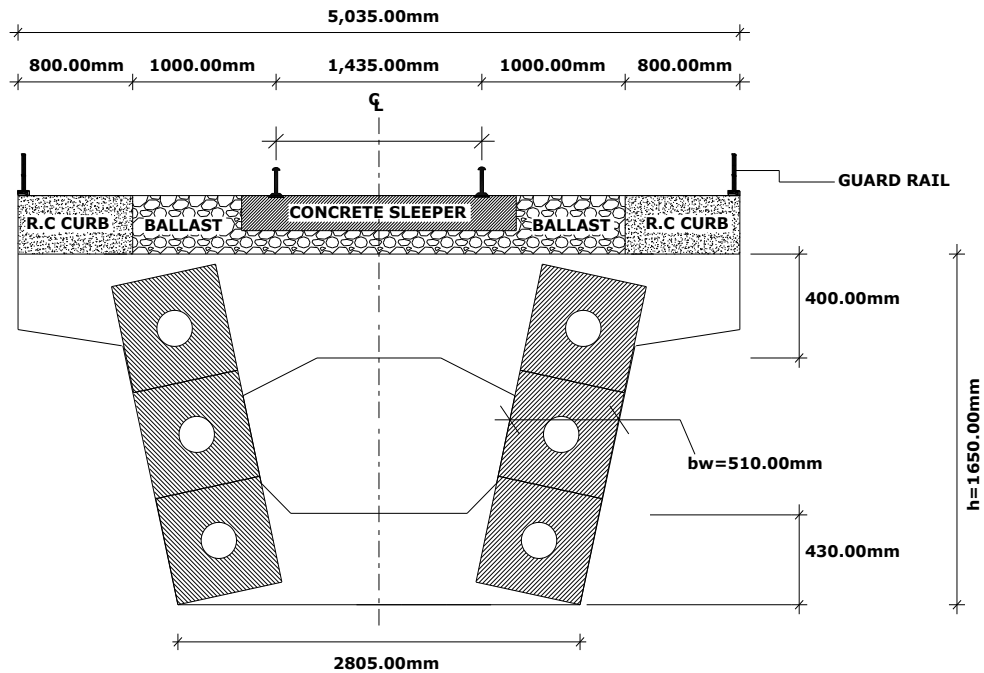

FIGURE A12: BEARING PLATES ARRANGEMENT (BOX GIRDER)

Use 2 Anchorage Bearing Plate with the following dimensions:

Bearing Plate Width = 488.00mm,

Bearing Plate Length = 1,500.00mm,

Concentric Area Width = 488.00mm,

Concentric Area Length = 1,500.00mm,

$A_{gb} = 732,000.00\text{mm}^2$ , and

$A = 732,000.00\text{mm}^2$ .

Then,

$f_{br} = 25.20\text{MPa}$  (Allowable bearing stress under the anchorage device).

**$f_{br} = 25.20\text{MPa} \leq 2.25f'_{ci} = 81.00\text{MPa}$  ..... OK!**

Check actual bearing stress:

Prestressing Force,  $P = 36,217.94\text{KN}$ ,

Anchorage Devices = 2,

Bearing Plate Area =  $732,000.00\text{mm}^2$ ,

**Actual Bearing Stress =  $24.74\text{MPa} \leq f_{br} = 25.20\text{MPa}$  ..... OK!**

### STEP 19: DETERMINE THE REINFORCEMENT REQUIRED TO RESIST THE BURSTING STRESSES

In order to determine the reinforcement required to resist the bursting forces in the anchorage zones, we need to find the acting force using the strut-and-tie model shown below.

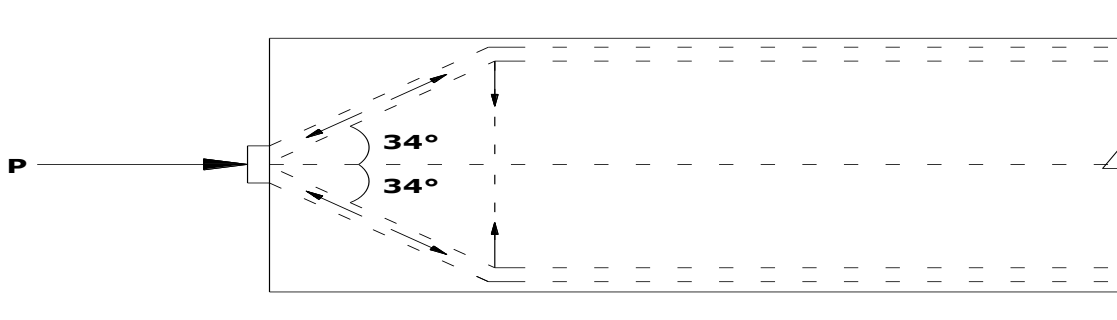

FIGURE A13: STRUT-AND-TIE MODEL OF THE ANCHORAGE ZONE (BOX GIRDER)

Maximum Prestressing Force acting on each end anchorage device = 18,108.97KN,

**Then, Bursting Force = (Prestressing Force) X (tan34°) = 12,206.73KN.**

Use closed mild reinforcements with Yield Strength  $f_{sy} = 347.83\text{MPa}$ ,

Required Reinforcement = (Bursting Force)/( $f_{sy}$ ) = 35,094.95mm<sup>2</sup>.

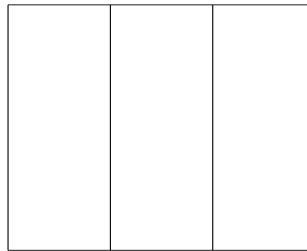

FIGURE A14: REINFORCEMENT PATTERN FOR BURSTING FORCES (BOX GIRDER)

Using 10.00mm bars with the pattern shown above:

$A_v = 314.00\text{mm}^2$  (Note:  $A_v = 0.25 \times 3.14 \times (\text{diameter})^2 \times 4$  ..... 4 because 4 legs),

Number of Bars = 114.

Thus, provide 112 diameter 10mm closed bars, with the pattern shown above, around each anchorage device to resist bursting forces. These bars should be placed uniformly over a length equal to the greatest lateral dimension of the effective end-block dimension, which is 2805mm. Alternatively, anchorage devices which are fabricated with spiral reinforcements to resist these bursting forces can be also used if available.

#### **STEP 20: CONSTRUCTION COST ESTIMATION OF THE BRIDGE SUPERSTRUCTURE**

This involves quantifying the volume of bridge superstructure work items in order to estimate the approximate construction costs for each span combination. In this regard, the volume of C50 Concrete, form work to Concrete, the lengths of the prestressing tendons, and mild reinforcement bars shall be taken into consideration using the unit prices assumed to estimate the construction cost.



<b>TABLE A8: CONSTRUCTION COST ESTIMATE FOR BOX GIRDER WITH SPAN COMBINATION 33.00-34.00-33.00m</b>					
<b>ITEM</b>	<b>WORKS DESCRIPTION</b>	<b>UNIT</b>	<b>QUANTITY</b>	<b>UNIT PRICE</b>	<b>AMOUNT (BIRR)</b>
<b>1</b>	<b>C50 CONCRETE</b>	<b>m<sup>3</sup></b>	<b>395.34</b>	<b>4,000.00</b>	<b>1,581,346.20</b>
<b>2</b>	<b>FORM WORK TO CONCRETE</b>	<b>m<sup>2</sup></b>	<b>1,003.45</b>	<b>400.00</b>	<b>401,381.60</b>
<b>3</b>	<b>DIAMETER 15.24mm TENDONS</b>	<b>m</b>	<b>15,965.83</b>	<b>400.00</b>	<b>8,273,327.89</b>
<b>4</b>	<b>ALL MILD REINFORCEMENT BARS</b>	<b>Kg</b>	<b>9,677.10</b>	<b>40.00</b>	<b>387,083.89</b>
<b>TOTAL AMOUNT (BIRR)</b>					<b><u>10,643,139.58</u></b>

**G. REINFORCEMENT DETAIL FOR BOX GIRDER**

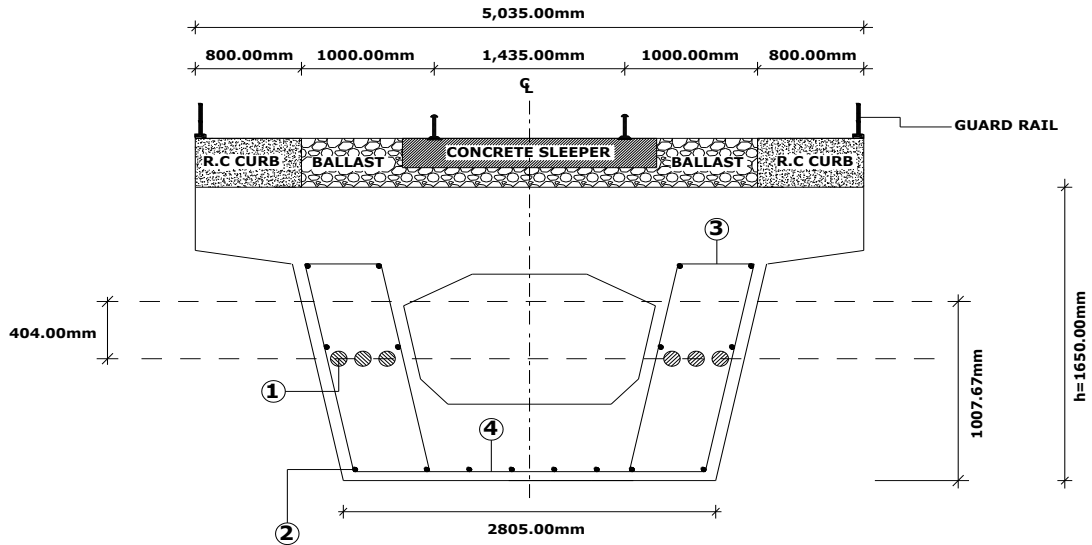

**LEGEND:**

- ① DUCTS (INNER DIAMETER = 80.00mm WITH TOTAL TENDONS No. =199)
- ② MILD REINFORCEMENT (DIAMETER=24mm, No. =18, LENGTH = 101.60m)
- ③ WEB SHEAR REINFORCEMENT (S=620mm, No. =162, LENGTH = 3.20m)
- ④ MILD REINFORCEMENT (DIAMETER=16, No. =126, LENGTH = 2.20m, S=800mm)

FIGURE A15: BOX GIRDER REINFORCEMENT DETAIL AT SPAN

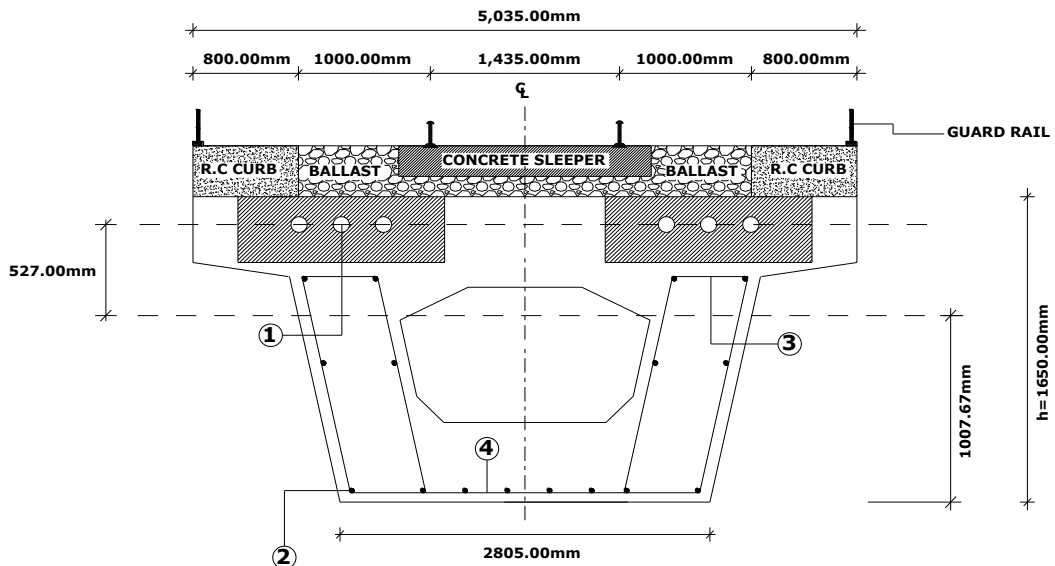

**LEGEND:**

- ① DUCTS (INNER DIAMETER = 80.00mm WITH TOTAL TENDONS No. =199)
- ② MILD REINFORCEMENT (DIAMETER=24mm, No. =18, LENGTH = 101.60m)
- ③ WEB SHEAR REINFORCEMENT (S=620mm, No. =162, LENGTH = 3.20m)
- ④ MILD REINFORCEMENT (DIAMETER=16, No. =126, LENGTH = 2.20m, S=800mm)

FIGURE A16: BOX GIRDER REINFORCEMENT DETAIL AT SUPPORT

**H. COMPLETE DESIGN OF A THREE SPAN CONTINUOUS POST-TENSIONED  
T-GIRDER RAILWAY BRIDGE**

## PRESTRESSED CONCRETE RAILWAY BRIDGES DESIGN (T-GIRDER)

STEP 1: SELECT SPAN COMBINATION: 33.00m - 34.00m - 33.00m

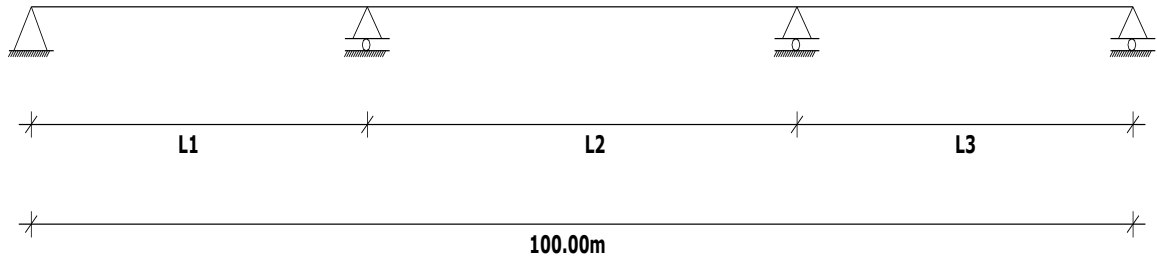

FIGURE A17: THREE SPAN T-GIRDER CONTINUOUS BRIDGE

STEP 2: DETERMINE CROSS SECTION GEOMETRY

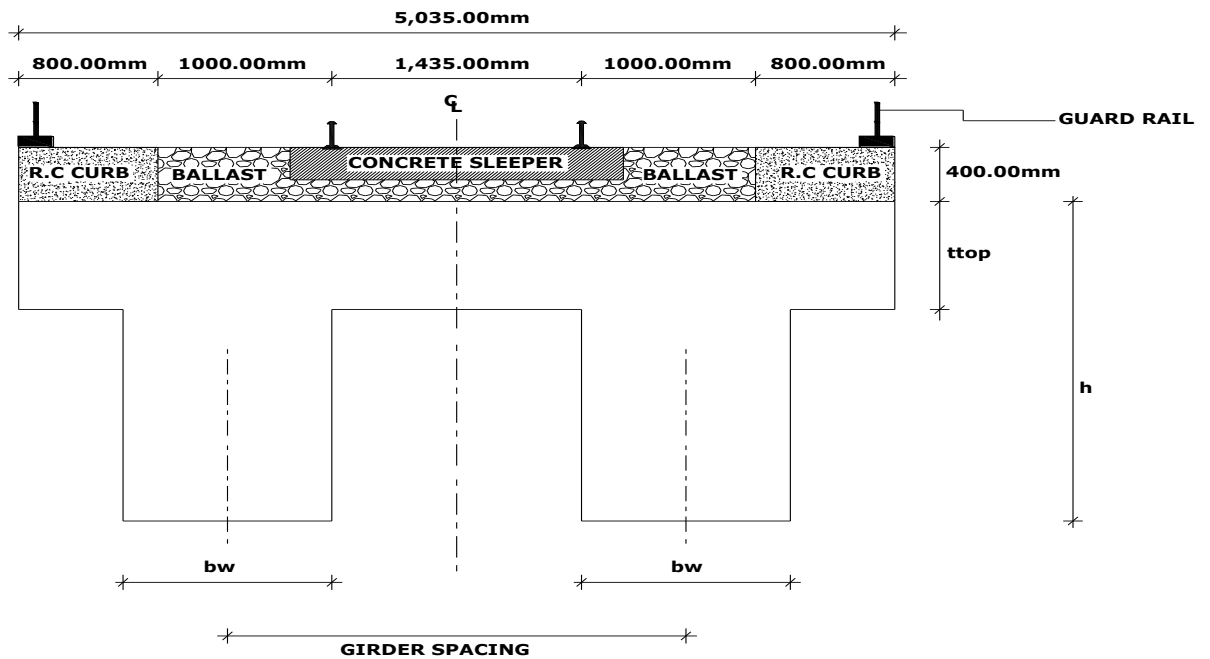

FIGURE A18: TYPICAL T-GIRDER BRIDGE CROSS SECTION

### I. STRUCTURAL DEPTH (h):

For Prestressed Continuous Spans, the Structural depth  $d$  shall be determined as  $h = 0.04L$  (AASHTO LRFD Table 2.5.2.6.3-1.). Where,  $L$  = the span of the longest segment of the continuous structure.

We have:

SPAN L1 = 33.00m,

SPAN L2 = 34.00m,

SPAN L3 = 33.00m,

Then,  $h = 1,360.00\text{mm}$ .

After a number of trial iterations, the total depth of the structure with the given span combination, fulfilling all the design requirements is found to be:

**Use  $h = 1,610.00\text{mm}$  ( $h$  = total depth of the section)**

### II. DETERMINE THE NUMBER OF CELL BOXES (GIRDERS):

The number of cell box to be used shall be determined based on the ratio  $h/b$ , where  $h$  is the structural depth and  $b$  is the width of the top flange..... AREMA Article C-26.17.4 (c).

$h/b \geq 0.17$  ..... use single cell box,

$h/b < 0.17$  ..... use double cell box.

$h = 1,480.00\text{mm}$  ..... ( $h$  = total depth of the section)

$b = 5,035.00\text{mm}$  ..... (Refer to Chapter 5: Design Parameters and Assumptions)

**Thus,  $h/b = 0.29 > 0.17$  ..... Use single Cell Box (2 Girders).**

### III. SPACING OF GIRDERS:

The Spacing of Girders is generally taken no more than twice their depth (BRIDGE ENGINEERING HAND BOOK, 2000).

Take Girder Spacing =  $2,635.00\text{mm} \leq 2h = 3,220.00\text{mm}$  ..... OK!

**IV. WEB THICKNESS ( $b_w$ ):**

The minimum web thickness is specified to be 7in. (175.00mm) ..... AREMA Article C-26.17.2.

**Take Web Thickness  $b_w = 0.58 * h = 933.80\text{mm} > 175.00\text{mm}$**

**V. TOP FLANGE THICKNESS ( $t_{top}$ ):**

The minimum thickness of the top slab shall be determined as  $t_{top,min} = (S_s + 3)/17$ ; where,  $S_s$  is the slab clear span in meters..... AREMA Article 2.23.11.c(1).

**Take Flange Thickness ( $t_{top}$ ) =  $0.25 * h = 402.50\text{mm} > 280\text{mm}$**

**STEP 3: DETERMINE CROSS SECTION PROPERTIES**

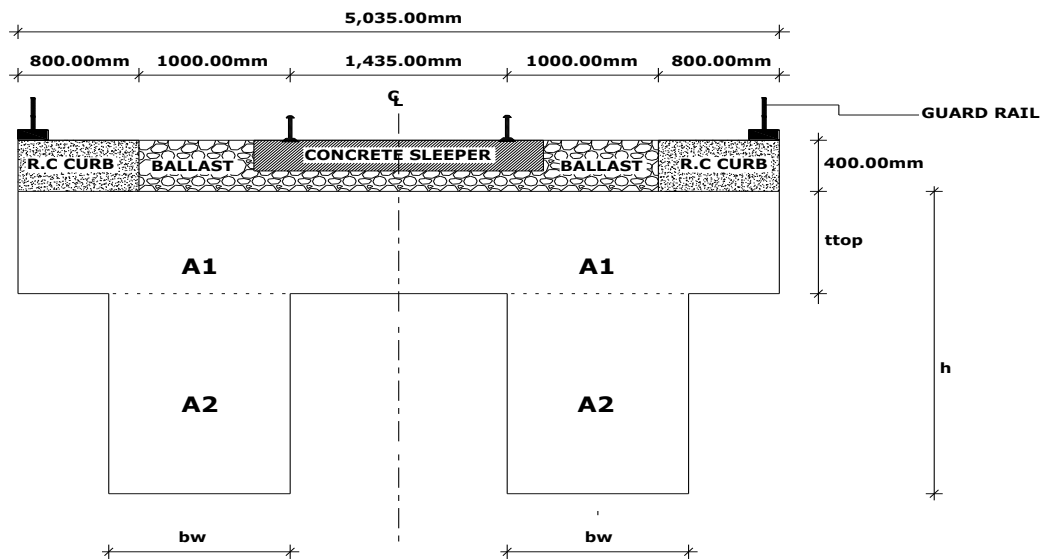

FIGURE A19: T-GIRDER CROSS SECTION PROPERTIES

TABLE A9: LOCATION OF CENTROID DETERMINATION (T- GIRDER)						
AREA	w (mm)	h (mm)	A (mm <sup>2</sup> )	y (mm)	A*y (mm <sup>3</sup> )	$\bar{y}$
A1	2,517.50	402.50	2,026,587.50	1,408.75	2,854,955,140.63	
A2	933.80	1,207.50	2,255,127.00	603.75	1,361,532,926.25	
$\Sigma$			<b>4,281,714.50</b>		<b>4,216,488,066.88</b>	<b><u>984.77</u></b>

Location of Centroid measured from the bottom extreme fiber ( $\bar{y}$ ) = 984.77mm,  
 Distance from centroid to extreme top fiber of the cross section ( $y_t$ ) = 625.23mm,  
 Distance from centroid to extreme bottom fiber of the cross section ( $y_b$ ) = 984.77mm.

<b>TABLE A10: DETERMINATION OF MOMENT OF INERTIA ABOUT THE CENTROID OF THE SECTION (T-GIRDER)</b>						
<b>AREA</b>	<b>w (mm)</b>	<b>h (mm)</b>	<b>A (mm<sup>2</sup>)</b>	<b>I<sub>x</sub> (mm<sup>4</sup>)</b>	<b>d<sub>y</sub> (mm)</b>	<b>A*d<sub>y</sub><sup>2</sup> (mm<sup>4</sup>)</b>
<b>A1</b>	2,517.50	402.50	2,026,587.50	1.37E+10	-423.98	3.64E+11
<b>A2</b>	933.80	1,207.50	2,255,127.00	1.37E+11	381.02	3.27E+11
<b>Σ</b>				<b>1.51E+11</b>		<b>6.92E+11</b>

**Note:**  $d_y = \bar{y} - y$

Moment of Inertia about the centroid of cross section ( $I_x$ ):

$$I_x = \sum I_x + \sum A * d_y^2 = 8.42E+11 \text{mm}^4$$

Section Modulus for the extreme top fiber of the cross section:

$$S_t = I_x / y_t = 1.35E+09 \text{mm}^3$$

Section Modulus for the extreme bottom fiber of the cross section:

$$S_b = I_x / y_b = 8.55E+08 \text{mm}^3$$

**STEP 4: DETERMINE DESIGN VALUES FOR SHEAR AND BENDING MOMENT (LOAD FACTOR DESIGN)**

**LOAD FACTOR DESIGN:** Structures and structural members shall be designed to have design strengths at all sections at least equal to the required strengths calculated for the factored loads and forces in such combinations as stipulated in Article 2.2.4c which represent various combinations of loads and forces to which a structure may be subjected. Each part of such, structure shall be proportioned for the group loads that are applicable, and the maximum design required shall be used .....AREMA Article 2.30.1.

**I. GIRDER DEAD LOAD (SELF WEIGHT):**

Unit Weight of Concrete  $W_c = 25.00 \text{KN/m}^3$

Total Cross Sectional Area  $A_c = 4.28 \text{m}^2$



**Dead Load (Self Weight) = (Unit Weight of Concrete)\*(Total Cross Sectional Area) = 107.04KN/m.**

## **II. SUPER IMPOSED LOADS:**

Super Imposed Loads consist of loads from Ballast, Ties, Rails, Curbs, Hand Rails, etc.

AREMA ARTICLE 2.2.3 b(2) recommends the following materials unit weights to be used:

Track rails, inside guardrails and fastenings = 3.00KN/m,

Ballast, including track ties =  $1900 \text{ kg/m}^3 = 19.00\text{KN/m}$ ,

### **Ballast and Track Ties**

Area of Ballast and track ties =  $3.435 \times 0.40\text{m} = 1.34\text{m}^2$

Super Imposed Load from Ballast and track ties = 24.51KN/m.

Concrete Curbs (on either side of the Bridge)

Unit Weight of Concrete =  $25.00\text{KN/m}^3$

Area of Concrete Curbs =  $(0.80 \times 0.40\text{m}) \times 2 = 0.64\text{m}^2$

Super Imposed Load from Concrete Curbs = 16.00KN/m.

### **Track Rails, Guard Rails and Fastenings**

Super Imposed Load from Rails and Fastenings = 3.00KN/m.

**Total Super Imposed Loads = 44.41KN/m.**

## **III. LIVE LOAD:**

**The recommended Live Load for Railway Structures is Cooper E 80 AREMA Article 2.2.3(d).**

Live load from a single track acting on the top surface of a structure with ballasted deck or under fills shall be assumed to have uniform lateral distribution over a width equal to the

length of track tie plus the depth of ballast and fill below the bottom of tie, unless limited by the extent of the structure .....AREMA Article 2.2.3.c(3).

Length of the track tie (sleeper) = 2,200.00mm,

Depth of ballast and fill below the bottom of tie = 400.00mm,

The Live Load shall be laterally distributed over a width = 2,200 + 400 = 2,600.00mm.

The values of the actions (Shear Forces and Bending Moments) which are obtained from the Structural Analysis shall be assumed to act on a strip of width 2400.00mm. Thus, divide the values of the actions (Shear Force and Bending Moments) obtained from analysis by 2.60m for design.

**IV. IMPACT LOAD:**

The Impact Load shall be equal to the following percentages of the Live Load:

**For  $L \leq 4m$ ,  $I = 60$ ,**

**For  $4m \leq L \leq 39m$ ,  $I = (125/\sqrt{L})$ ,**

**For  $L > 39m$ ,  $I = 20$ .**

Span (m) =	33.00	34.00	33.00
Impact Load Factor =	0.22	0.21	0.22

**Thus, Impact Load Factor = 0.22.**

According to AREMA (2010) Article 2.2.4 C(1) Table 8-2-5, for Load Factor Design, the maximum values of the following loading combinations shall be used for design:

**GROUP I:  $1.4 (D + 5/3 (L + I) + CF + E + B + SF)$  ..... (GOVERNS)**

**GROUP IA:  $1.8 (D + L + I + CF + E + B + SF)$**

<b>TABLE A11: OUTPUTS OF THE STRUCTURAL ANALYSIS FOR EACH SEGMENT (MAXIMUM VALUES FOR T-GIRDER)</b>				
<b>SPAN</b>	<b>LOADING</b>	<b>BENDING MOMENT (KNm)</b>		<b>SHEAR FORCE (KN)</b>
		<b>AT SPAN</b>	<b>AT SUPPORT</b>	
<b>L1</b>	<b>DEAD LOAD</b>	9,222.56	12,020.42	2,135.83
	<b>SUPER IMPOSED LOADS</b>	3,842.86	5,008.67	889.96
	<b>LIVE LOAD (COOPER E-80)</b>	6,296.72	6,676.28	1,222.11
<b>FACTORED DESIGN VALUES FOR SPAN L1</b>		<b>36,180.95</b>	<b>42,808.44</b>	<b>7,708.20</b>
<b>L2</b>	<b>DEAD LOAD</b>	3,494.29	12,020.42	1,825.26
	<b>SUPER IMPOSED LOADS</b>	1,456.00	5,008.67	760.55
	<b>LIVE LOAD (COOPER E-80)</b>	5,008.65	6,676.28	1,175.98
<b>FACTORED DESIGN VALUES FOR SPAN L2</b>		<b>21,160.29</b>	<b>42,808.44</b>	<b>6,961.18</b>
<b>L3</b>	<b>DEAD LOAD</b>	9,222.56	12,020.42	2,135.83
	<b>SUPER IMPOSED LOADS</b>	3,842.86	5,008.67	889.96
	<b>LIVE LOAD (COOPER E-80)</b>	6,296.72	6,676.28	1,222.11
<b>FACTORED DESIGN VALUES FOR SPAN L3</b>		<b>36,180.95</b>	<b>42,808.44</b>	<b>7,708.20</b>
<i>Note: Structural Analysis results using Computer Program SAP2000 (Version 14) are used.</i>				

**MAXIMUM VALUES FOR DESIGN:**

TOTAL FACTORED SHEAR FORCE (KN) = 7,708.20KN,

TOTAL FACTORED (+VE) BENDING MOMENT (KNm) = 36,180.95KNm,

TOTAL FACTORED (-VE) BENDING MOMENT (KNm) = 42,808.44KNm,

**STEP 5: DETERMINE PERMISSIBLE STRESSES**

**I. PRESTRESSING TENDONS:**

Tensile Stress in Post-Tensioning shall not exceed  $0.82f_y$  or  $0.70f'_s$  whichever is larger, but not greater than  $0.70f'_s$  at end anchorage..... AREMA Article 17.16.1.2(a).

$f_y$  = Yield Strength of Tendons = 1,670.00MPa..... $0.82f_y = 1,369.40$ MPa

$f'_s$  = Ultimate Strength of Tendons = 1,860.00MPa..... $0.70f'_s = 1,302.00$ MPa

Thus,

TENDON ALLOWABLE TENSILE STRESS = 1,369.40MPa,

TENDON ALLOWABLE TENSILE STRESS = 1,302.00MPa (At End Anchorage).

**II. CONCRETE:**

**a.) ALLOWABLE STRESSES IN CONCRETE AT TRANSFER**

Compressive Stresses in Concrete immediately after prestress transfer (before time-dependent prestress losses-Creep and Shrinkage) for, Post-tensioned members, shall not exceed  $0.55f'_c$ . .....AREMA Article 17.16.2.1(a).

Compressive Strength of Concrete,  $f'_c = 40.00\text{MPa}$ ,  
ALLOWABLE COMPRESSIVE STRENGTH =  $22.00\text{MPa}$ .

Tensile Stresses in Concrete immediately after prestress transfer (before time-dependent prestress losses-Creep and Shrinkage) for Post-tensioned members, shall not exceed  $0.623(f'_{ci})^{1/2}$  for members with bonded auxiliary reinforcement with the assumption of uncracked section.....AREMA Article 17.16.2.1(b).

$f'_{ci}$  = Compressive Strength of Concrete at time of initial prestress =  $36.00\text{MPa}$ ,  
ALLOWABLE TENSILE STRENGTH =  $3.74\text{MPa}$ .

**b.) ALLOWABLE STRESSES IN CONCRETE AT SERVICE LOADS**

Compressive Stresses in Concrete at service loads (after allowance for all prestress losses) shall not exceed  $0.40f'_c$ .....AREMA Article 17.16.2.2.  
ALLOWABLE COMPRESSIVE STRENGTH =  $16.00\text{MPa}$ .

Tensile Stresses in Concrete at service loads (after allowance for all prestress losses) shall not exceed  $0.00$ .....AREMA Article 17.16.2.2.  
ALLOWABLE TENSILE STRENGTH =  $0.00\text{MPa}$ .

**STEP 6: DETERMINE THE CABLE PATH (LAYOUT)**

It is a general principle that the maximum eccentricity of prestressing tendons should occur at locations of maximum moments. Maximum eccentricities should occur at points of maximum dead load moments and almost no eccentricity should be present at the jacked end section.

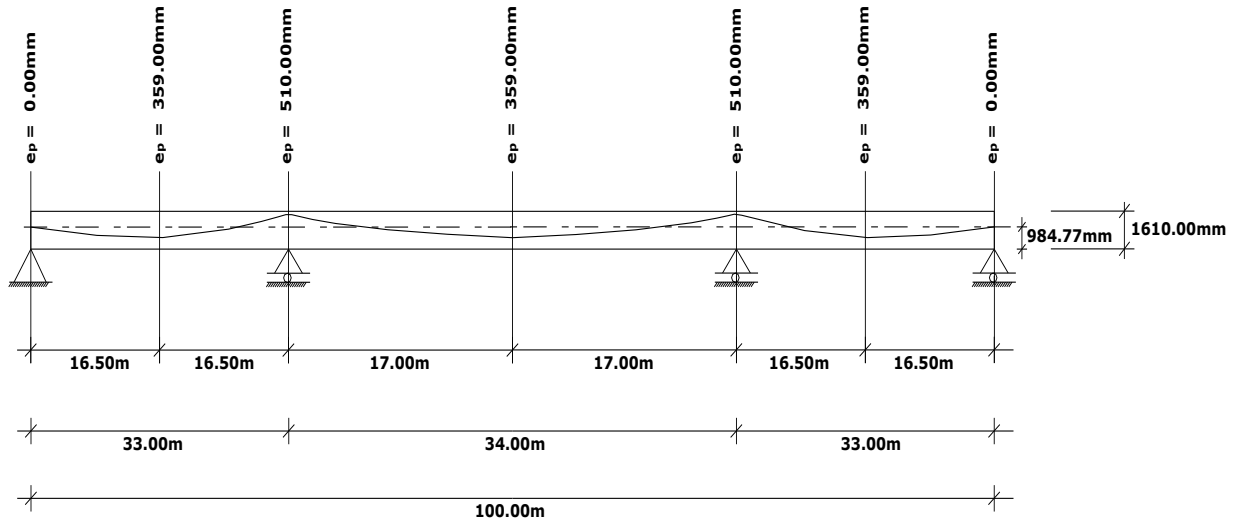

FIGURE A20: PRESTRESSING TENDON LAYOUT (T-GIRDER)

## STEP 7: DETERMINE THE REQUIRED PRESTRESSING FORCE

### I. AT SPAN

Maximum Eccentricity = 359.00mm

Bottom Tensile Stress due to Applied Loads is given as:  $f_b = (M_g + M_{SDL} + M_{LL+I})/S_b$

Where,

$f_b$  = Concrete Stress at the bottom fiber

$M_g$  = Unfactored Bending Moment due to Self Weight

$M_{SDL}$  = Unfactored Bending Moment due to Super Imposed Dead Load

$M_{LL+I}$  = Unfactored Bending Moment due to Live Load Plus Impact

$S_b$  = Section Modulus for the Extreme Bottom Fiber

Thus,

$$M_g = 9,222.56\text{KNm} = 9.22\text{E}+09\text{Nmm}$$

$$M_{SDL} = 3,842.86\text{KNm} = 3.84\text{E}+09\text{Nmm}$$

$$M_{LL+I} = 7,666.87\text{KNm} = 7.67\text{E}+09\text{Nmm}$$

$$S_b = 8.55\text{E}+08\text{mm}^3$$

$$f_b = 24.24\text{N/mm}^2 = 24.24\text{MPa.}$$

Since the allowable concrete tensile stress in bottom fiber at service load is zero, the required pre-compression shall be equivalent to the tensile stress due to the applied loads  $f_b$ .

**Thus, the required pre-compression = 24.24MPa.**

**Bottom Fiber Stress due to Prestress after Losses =  $f_b = P_{se}/A + P_{se} * e_p/S_b$**

Where,

$f_b$  = Concrete Stress at the Bottom Fiber due to Prestressing

$P_{se}$  = Effective Prestressing Force after allowing for all losses

$A$  = Cross Sectional Area

$e_p$  = Strands Eccentricity

$S_b$  = Section Modulus for the Extreme Bottom Fiber

We have:

$f_b = 24.24\text{MPa}$ ,

$A = 4.28\text{E}+06\text{mm}^2$ ,

$e_p = 359.00\text{mm}$ ,

$S_b = 8.55\text{E}+08\text{mm}^3$ ,

Solving for  $P_{se}$  from the relationship  $f_b = P_{se}/A + P_{se} * e_p/S_b$  gives

**$P_{se} = 37,102.74\text{KN}$  (the required effective prestressing force after all losses at span).**

## II. AT SUPPORT

Maximum Eccentricity = 510.00mm

Top Fiber Tensile Stress due to Applied Loads is given as:  $f_t = (M_g + M_{SDL} + M_{LL+I})/S_t$

Where,

$f_t$  = Concrete Stress at the top fiber

$M_g$  = Unfactored Bending Moment due to Self Weight

$M_{SDL}$  = Unfactored Bending Moment due to Super Imposed Dead Load

$M_{LL+I}$  = Unfactored Bending Moment due to Live Load Plus Impact

$S_t$  = Section Modulus for the Extreme Top Fiber

Thus,

$$M_g = 12,020.42 \text{KNm} = 12.0\text{E}+10 \text{Nmm}$$

$$M_{\text{SDL}} = 5,008.67 \text{KNm} = 5.01\text{E}+09 \text{Nmm}$$

$$M_{\text{LL+I}} = 8,129.02 \text{KNm} = 8.12\text{E}+09 \text{Nmm}$$

$$S_t = 1.35\text{E}+09 \text{mm}^3$$

$$f_t = 18.67 \text{N/mm}^2 = 18.67 \text{MPa}.$$

Since the allowable concrete tensile stress in top fiber at service load is zero, the required pre-compression shall be equivalent to the tensile stress due to the applied loads  $f_t$ .

**Thus, the required pre-compression = 18.67MPa.**

$$\text{Top Fiber Stress due to Prestress after Losses} = f_t = P_{se}/A + P_{se} * e_p / S_t$$

Where,

$f_t$  = Concrete Stress at the Top Fiber due to Prestressing

$P_{se}$  = Effective Prestressing Force after allowing for all losses

$A$  = Cross Sectional Area

$e_p$  = Strands Eccentricity

$S_t$  = Section Modulus for the Extreme Top Fiber

We have:

$$f_t = 15.73 \text{MPa},$$

$$A = 4.28\text{E}+06 \text{mm}^2,$$

$$e_p = 510.00 \text{mm},$$

$$S_t = 1.35\text{E}+09 \text{mm}^3$$

Solving for  $P_{se}$  from the relationship  $f_t = P_{se}/A + P_{se} * e_p / S_t$  gives

$$P_{se} = 30,507.18 \text{KN} \text{ (the required effective prestressing force after all losses at support).}$$

**Thus,  $P_{se} = 37,102.74 \text{KN}$  (span governs).**

Note: For Post-Tensioned members, an average of 18% prestress loss can be considered with the assumption of applying over tensioning to overcome friction and anchorage losses.

Assume Prestress Losses = 18.00%

**Prestressing Force, P = 43,781.23KN.**

**STEP 8: DETERMINE THE REQUIRED NUMBER OF STRANDS**

Strand Diameter = 15.24mm,

Strand Area = 140.00mm<sup>2</sup>,

Prestressing Force, P = 43,781.23KN,

Allowable Tensile Stress = 1,302.00MPa (At End Anchorage),

Required Number of Strands = (Prestressing Force)/ (Allowable Tensile Stress \* Strand Area)

**Thus, Number of Strands = 240.**

**STEP 9: CHECK STRESSES IN CONCRETE (AT TRANSFER)**

**I. AT SPAN**

Maximum Eccentricity = 359.00mm,

**Top Fiber Stress after Losses =  $f_t = P_{se}/A - P_{se} * e_p/S_t + M_g/S_t$**

Where,

$P_{se}$  = Effective Prestressing Force after allowing for all losses = 37,102.74KN,

A = Cross Sectional Area = 4,281,714.50mm<sup>2</sup>,

$e_p$  = 359.00mm,

$M_g$  = Unfactored Bending Moment due to Self Weight = 9,222.56KNm,

$S_t$  = Section Modulus for the Extreme Bottom Fiber = 1.35E+09mm<sup>3</sup>,

**Then,  $f_t = 5.62\text{MPa (Compressive)} < 22.00\text{ MPa} \dots\dots\dots\text{OK!}$**

**Bottom Fiber Stress after Losses =  $f_b = P_{se}/A + P_{se} * e_p/S_b - M_g/S_b$**



Where,

$P_{se}$  = Effective Prestressing Force after allowing for all losses = 37,102.74KN,

$A$  = Cross Sectional Area = 4,281,714.50mm<sup>2</sup>,

$e_p$  = 359.00mm,

$M_g$  = Unfactored Bending Moment due to Self Weight = 9,222.56KNm,

$S_b$  = Section Modulus for the Extreme Bottom Fiber =  $S_b = 8.55E+08$ mm<sup>3</sup>,

**Then,  $f_b = 13.46$ MPa (Compressive) < 22.00 MPa .....OK!**

## II. AT SUPPORT

Maximum Eccentricity = 510.00mm

**Top Fiber Stress after Losses =  $f_t = P_{se}/A + P_{se} * e_p/S_t - M_g/S_t$**

Where,

$P_{se}$  = Effective Prestressing Force after allowing for all losses = 37,102.74KN,

$A$  = Cross Sectional Area = 4,281,714.50mm<sup>2</sup>,

$e_p$  = 510.00mm,

$M_g$  = Unfactored Bending Moment due to Self Weight = 12,020.42KNm,

$S_t$  = Section Modulus for the Extreme Bottom Fiber = 1.35E+09mm<sup>3</sup>,

**Then,  $f_t = 13.79$ MPa (Compressive) < 22.00 MPa .....OK!**

**Bottom Fiber Stress after Losses =  $f_b = P_{se}/A - P_{se} * e_p/S_b + M_g/S_b$**

Where,

$P_{se}$  = Effective Prestressing Force after allowing for all losses = 37,102.74KN,

$A$  = Cross Sectional Area = 4,281,714.50mm<sup>2</sup>,

$e_p$  = 510.00mm,

$M_g$  = Unfactored Bending Moment due to Self Weight = 12,020.42KNm,

$S_b$  = Section Modulus for the Extreme Bottom Fiber =  $S_b = 8.55E+08$ mm<sup>3</sup>,

**Then,  $f_b = 0.60$ MPa (Compressive) < 22.00 MPa .....OK!**

## STEP 10: CHECK STRESSES IN CONCRETE AT END ANCHORAGES (AT TRANSFER)

Maximum Eccentricity = 0.00mm

**Bottom Fiber Stress after Losses =  $f_b = P_{se}/A + P_{se} * e_p/S_b - M_g/S_b$**

Where,

$P_{se}$  = Effective Prestressing Force after allowing for all losses = 37,102.74KN,

$A$  = Cross Sectional Area = 4,281,714.50mm<sup>2</sup>,

$e_p$  = 0.00mm,

$M_g$  = Unfactored Bending Moment due to Self Weight = 0.00KNm,

$S_b$  = Section Modulus for the Extreme Bottom Fiber =  $S_b = 8.55E+08mm^3$ ,

**Then,  $f_b = 8.67MPa$  (Compressive) < 22.00 MPa .....OK!**

**Top Fiber Stress after Losses =  $f_t = P_{se}/A - P_{se} * e_p/S_t + M_g/S_t$**

Where,

$P_{se}$  = Effective Prestressing Force after allowing for all losses = 37,102.74KN,

$A$  = Cross Sectional Area = 4,281,714.50mm<sup>2</sup>,

$e_p$  = 0.00mm,

$M_g$  = Unfactored Bending Moment due to Self Weight = 0.00KNm,

$S_t$  = Section Modulus for the Extreme Bottom Fiber =  $1.35E+09mm^3$ ,

**Then,  $f_t = 8.67MPa$  (Compressive) < 22.00 MPa .....OK!**

**STEP 11: CHECK STRESSES IN CONCRETE (AT SERVICE LOADS)**

**I. AT SPAN**

Maximum Eccentricity = 359.00mm

**Top Fiber Stress after Losses =  $f_t = P_{se}/A - P_{se} * e_p/S_t + (M_g + M_{SDL} + M_{LL+I})/S_t$**

Where,

$P_{se}$  = Effective Prestressing Force after allowing for all losses = 37,102.74KN,

$A$  = Cross Sectional Area = 4,281,714.50mm<sup>2</sup>,

$e_p$  = 359.00mm,

$M_g$  = Unfactored Bending Moment due to Self Weight = 9,222.56KNm,

$M_{SDL}$  = Unfactored Bending Moment Super Imposed Dead Load = 3,842.86KNm,

$M_{LL+I}$  = Unfactored Bending Moment due to Live Load + Impact = 7,666.87KNm,

$S_t$  = Section Modulus for the Extreme Bottom Fiber =  $1.35E+09\text{mm}^3$ ,

**Then,  $f_t = 14.17\text{MPa}$  (Compressive) <  $16.00\text{ MPa}$  .....OK!**

**Bottom Fiber Stress after Losses =  $f_b = P_{se}/A + P_{se} * e_p/S_b - (M_g + M_{SDL} + M_{LL+I})/S_b$**

Where,

$P_{se}$  = Effective Prestressing Force after allowing for all losses =  $37,102.74\text{KN}$ ,

$A$  = Cross Sectional Area =  $4,281,714.50\text{mm}^2$ ,

$e_p$  =  $359.00\text{mm}$ ,

$M_g$  = Unfactored Bending Moment due to Self Weight =  $9,222.56\text{KNm}$ ,

$M_{SDL}$  = Unfactored Bending Moment Super Imposed Dead Load =  $3,842.86\text{KNm}$ ,

$M_{LL+I}$  = Unfactored Bending Moment due to Live Load + Impact =  $7,666.87\text{KNm}$ ,

$S_b$  = Section Modulus for the Extreme Bottom Fiber =  $S_b = 8.55E+08\text{mm}^3$ ,

**Then,  $f_b = 0.00\text{MPa}$  (Tension) <  $0.00\text{ MPa}$  .....OK!**

## II. AT SUPPORT

Maximum Eccentricity =  $510.00\text{mm}$

**Top Fiber Stress after Losses =  $f_t = P_{se}/A + P_{se} * e_p/S_t - (M_g + M_{SDL} + M_{LL+I})/S_t$**

Where,

$P_{se}$  = Effective Prestressing Force after allowing for all losses =  $37,102.74\text{KN}$ ,

$A$  = Cross Sectional Area =  $4,281,714.50\text{mm}^2$ ,

$e_p$  =  $510.00\text{mm}$ ,

$M_g$  = Unfactored Bending Moment due to Self Weight =  $12,020.42\text{KNm}$ ,

$M_{SDL}$  = Unfactored Bending Moment Super Imposed Dead Load =  $5,008.67\text{KNm}$ ,

$M_{LL+I}$  = Unfactored Bending Moment due to Live Load + Impact =  $8,129.02\text{KNm}$ ,

$S_t$  = Section Modulus for the Extreme Bottom Fiber =  $1.35E+09\text{mm}^3$ ,

**Then,  $f_t = 4.04\text{MPa}$  (Compressive) <  $16.00\text{ MPa}$  .....OK!**

**Bottom Fiber Stress after Losses =  $f_b = P_{se}/A - P_{se} * e_p/S_b + (M_g + M_{SDL} + M_{LL+I})/S_b$**

Where,

$P_{se}$  = Effective Prestressing Force after allowing for all losses = 37,102.74KN,

$A$  = Cross Sectional Area = 4,281,714.50mm<sup>2</sup>,

$e_p$  = 510.00mm,

$M_g$  = Unfactored Bending Moment due to Self Weight = 12,020.42KNm,

$M_{SDL}$  = Unfactored Bending Moment Super Imposed Dead Load = 5,008.67KNm,

$M_{LL+I}$  = Unfactored Bending Moment due to Live Load + Impact = 8,129.02KNm,

$S_b$  = Section Modulus for the Extreme Bottom Fiber =  $S_b = 8.55E+08\text{mm}^3$ ,

**Then,  $f_b = 15.96\text{MPa (Compressive)} < 16.00\text{ MPa}$  .....OK!**

### **STEP 12: CHECK STRESSES IN CONCRETE AT END ANCHORAGES (AT SERVICE LOADS)**

The Prestressing Force is at its maximum value at release, and Service Loads do not affect Stresses at the end of the structure. Thus, Stresses at release will govern at the end of the Structure and there is no need to check Stresses at the end at Service Loads.

### **STEP 13: DETERMINE SECONDARY MOMENTS DUE TO THE APPLICATION OF THE PRESTRESSING FORCE**

In addition to the primary moments ( $P \cdot e_p$ ), secondary moments ( $M_{sec.}$ ) are introduced in continuous structures as the prestressing is applied. Secondary moments develop in a prestressed member due to prestressing forces, and as a consequence of the constraint provided by the supports to the free movement of the prestressed member. If a prestressed member is allowed to displace freely, as in the case of determinate structures or precast members prior to alignment and installation, no secondary moments are generated. However, in most cast-in-place construction, where supports constrain movement of the prestressed member, secondary actions can be significant and therefore must be accounted for in the design. Secondary effects are typically not, however, included in the service stress analysis.

Assume a Parabolic Tendon Profile for the Structure as shown below:

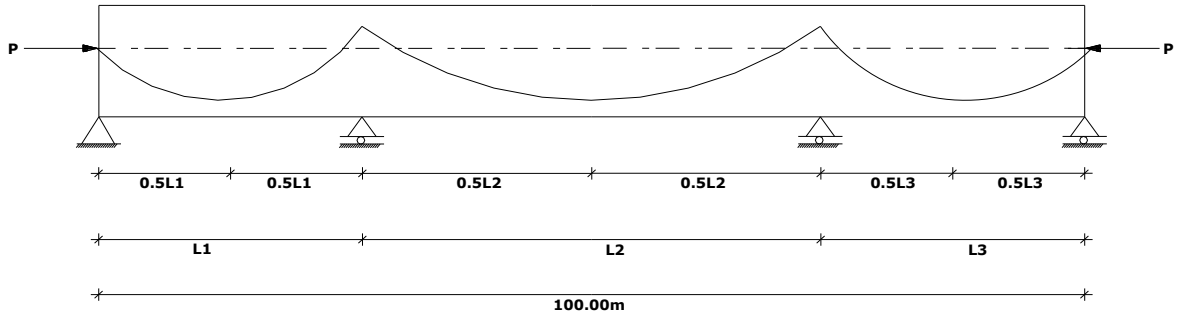

FIGURE A21: TENDON PROFILE (T-GIRDER)

Then, the equivalent upward tendon load exerted on the structure can be determined as  $w_t = (8 \cdot P \cdot e_p) / L^2$ .

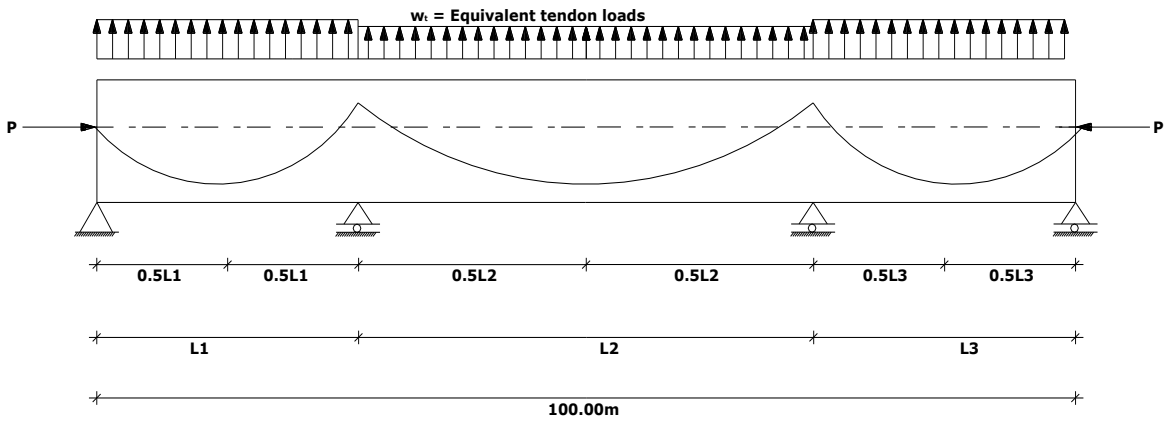

FIGURE A22: EQUIVALENT LOAD FOR PARABOLIC TENDON PROFILE (T-GIRDER)

The equivalent tendon load  $w_t$  will be:

$$e_p = 359.00\text{mm (at span),}$$

$$P_{se} = 37,102.74\text{KN,}$$

$$L1 = 33.00\text{m,}$$

$$L2 = 34.00\text{m,}$$

$$L3 = 33.00\text{m,}$$

Then,

$$w_{t1} = 97.85\text{KN/m (for span 1)}$$

$$w_{t2} = 92.18\text{KN/m (for span 2)}$$

$w_{t3} = 97.85 \text{KN/m}$  (for span 3)

Now, we will determine the reactions induced to restrain the upward movement of the beam at interior supports and the moments under the action of the equivalent tendon loads.

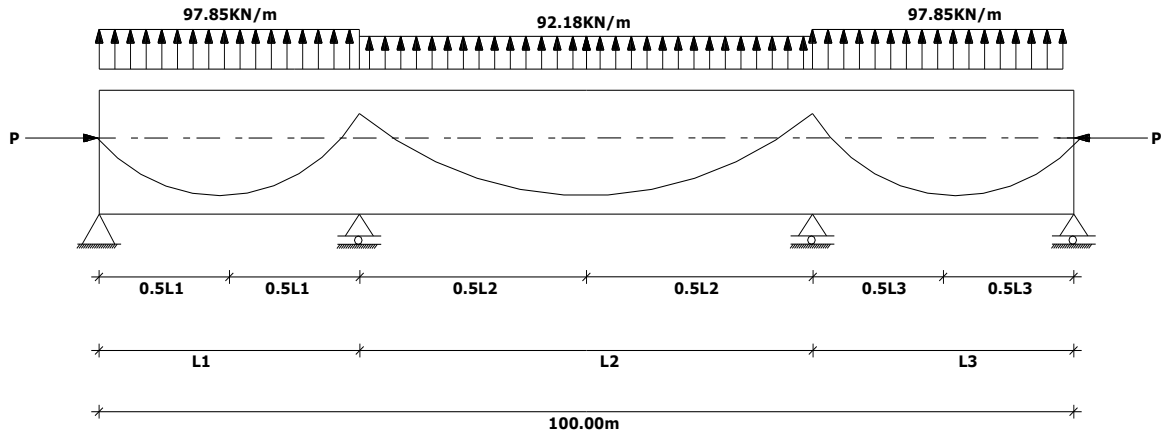

FIGURE A23: TENDON LOADS ACTING ON THE STRUCTURE (T-GIRDER)

Run structural analysis under the action of equivalent tendon loads:

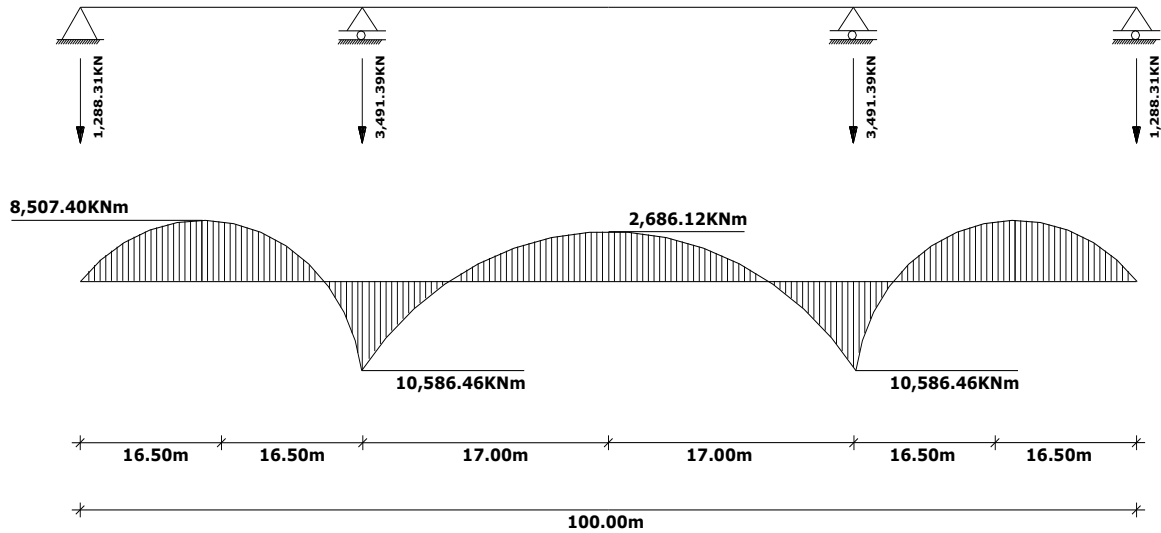

FIGURE A24: REACTIONS INDUCED UNDER THE ACTION OF THE PRESTRESSING FORCE (T-GIRDER)

Then, the balanced load moment is the moment under the action of the external which shall be counter acted by the action of the applied prestressing force. the external loading shall be equal to the equivalent tendon load, but opposite in direction. Thus, the balanced moment diagram will be equal to the moment under the action of the equivalent tendon loads but opposite in direction.

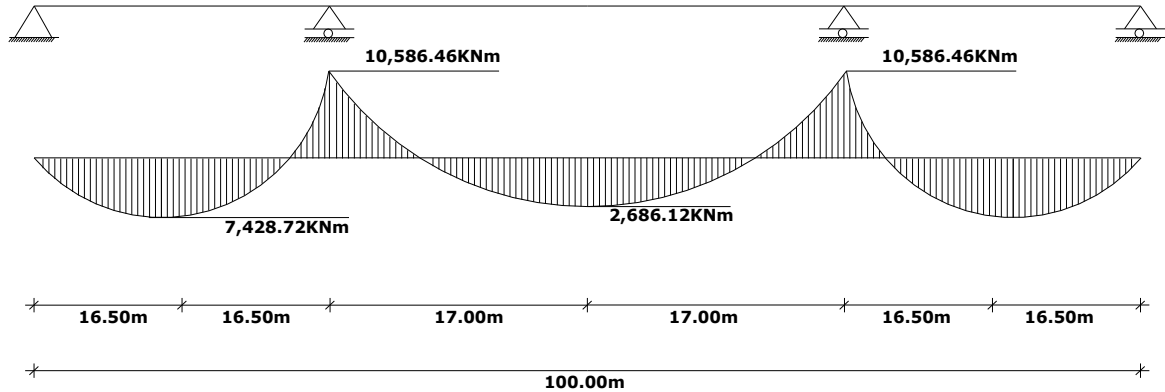

FIGURE A25: BALANCED MOMENT DIAGRAM (T-GIRDER)

Thus,

$$M_{\text{balanced}} = 7,428.72\text{KNm (at L1 mid-span),}$$

$$M_{\text{balanced}} = -10,586.46\text{KNm (at the first interior support),}$$

$$M_{\text{balanced}} = 2,686.12\text{KNm (at L2 mid-span),}$$

$$M_{\text{balanced}} = -10,586.46\text{KNm (at the second interior support),}$$

$$M_{\text{balanced}} = 7,428.72\text{KNm (at L3 mid-span).}$$

In order to determine the secondary moments, we need to estimate the primary moment  $M_1$  which is due to the eccentricity of the tendon profile with respect to the neutral axis:

$$M_1 = P_{se} * e_p$$

$$e_p = 359.00\text{mm (at span),}$$

$$e_p = -510.00\text{mm (at support),}$$

$$P_{se} = 37,102.74\text{KN,}$$

Then,

$$M_1 = 13,319.88\text{KNm (at L1 mid-span),}$$

$$M_1 = -18,922.40\text{KNm (at the first interior support),}$$

$$M_1 = 13,319.88\text{KNm (at L2 mid-span),}$$

$$M_1 = -18,922.40\text{KNm (at the second interior support),}$$

$$M_1 = 13,319.88\text{KNm (at L3 mid-span).}$$

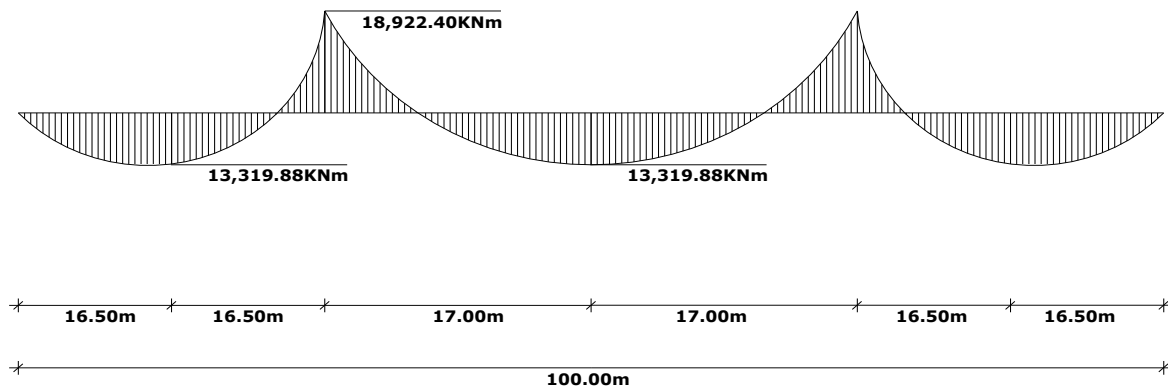

FIGURE A26: PRIMARY MOMENT DIAGRAM (T-GIRDER)

Then, the secondary moment  $M_{sec.}$  can be determined as  $M_{sec.} = M_{balanced} - M_1$ :

$$M_1 = -5,891.16\text{KNm (at L1 mid-span),}$$

$$M_{sec.} = 8,335.94\text{KNm (at the first interior support),}$$

$$M_{sec.} = -10,633.76\text{KNm (at L2 mid-span),}$$

$$M_{sec.} = 8,335.94\text{KNm (at the second interior support),}$$

$$M_{sec.} = -5,891.16\text{KNm (at L3 mid-span).}$$



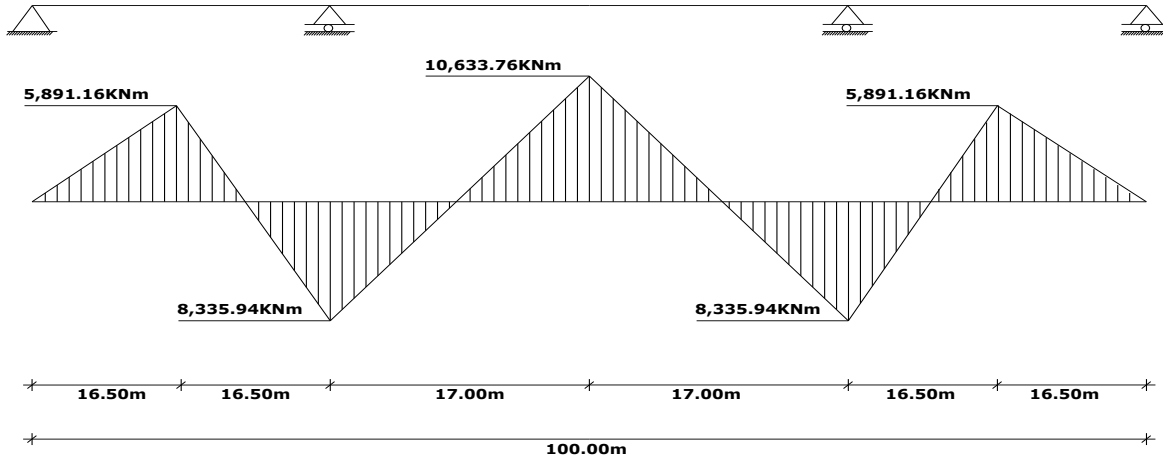

FIGURE A27: SECONDARY MOMENT DIAGRAM (T-GIRDER)

For design purpose, we will use the secondary moment which shall have the most extreme effect on the structure:

$$M_1 = -5,891.16 \text{ kNm (At span: tension at the top), } -5,891.16$$

$$M_{\text{sec.}} = 8,335.94 \text{ kNm (At support: tension at the bottom).}$$

Now, we will add the secondary moments obtained here to the dead load moments, superimposed load moment, live load + impact moments and check the ultimate strength of the section. Note that secondary moment is not factored because, in most cases, it counteracts the moments due to dead and live loading.

$$\text{FACTORED SPAN (+VE) BENDING MOMENT (kNm) = } 36,180.95 \text{ kNm,}$$

$$\text{FACTORED SUPPORT (-VE) BENDING MOMENT (kNm) = } -42,808.44 \text{ kNm,}$$

$$\text{SECONDARY MOMENT AT SPAN (kNm) = } -5,891.16 \text{ kNm,}$$

$$\text{SECONDARY MOMENT AT SUPPORT (kNm) = } 8,335.94 \text{ kNm,}$$

$$\text{TOTAL DESIGN (+VE) BENDING MOMENT AT SPAN (kNm) = } 30,289.79 \text{ kNm,}$$

$$\text{TOTAL DESIGN (-VE) BENDING MOMENT AT SUPPORT (kNm) = } -34,472.50 \text{ kNm.}$$

**STEP 14: CHECK THE ULTIMATE FLEXURAL STRENGTH OF THE SECTION**

**I. AT SPAN**

For rectangular or flanged sections with non-prestressed tension reinforcement included, in which the depth of the equivalent rectangular stress block, defined as  $(A_s^* f_{su}^* + A_s f_{sy}) / (0.85 f'_c b)$ , is not greater than the compression flange thickness “t”, the design flexural strength shall be assumed as:

$$\phi M_n = \phi \{ A_s^* f_{su}^* d [1 - 0.6((p^* f_{su}^* / f'_c) + (d_t / d)(p f_{sy} / f'_c))] + A_s f_{sy} d_t [1 - 0.6((d / d_t)(p^* f_{su}^* / f'_c) + (p f_{sy} / f'_c))] \} \dots\dots\dots \text{AREMA Article 17.18.2}$$

Where,

$\phi$  = Strength Reduction Factor (AREMA Article 17.15.1.b (1) = 0.95,

$A_s^*$  = Area of Prestressing Steel = 33,626.14mm<sup>2</sup>,

$f_{su}^*$  = Average Stress in Prestressing Steel at Ultimate Load = 1,369.40MPa,

$d$  = Distance from extreme compression fiber to centroid of the Prestressing Force =  $h - (\bar{y} - e_p) = 984.23\text{mm}$ ,

$d_t$  = Distance from the extreme compressive fiber to the centroid of the non-prestressed tension reinforcement (assume) = 2,400.00,

$p^*$  =  $A_s^* / (bd^*)$ , ratio of prestressing steel = 0.0068,

$p$  =  $A_s / (bdt)$  ratio of non-prestressed tension reinforcements = 0.0000,

$A_s$  = Area of Non-Prestressing Steel (provide 6 diameter 24 bars) = 0.00mm<sup>2</sup>,

$b$  = width of flange or width of rectangular member = 5,035.00mm,

$f'_c$  = Compressive Strength of Concrete at 28 days = 40.00MPa,

$f_{sy}$  = Yield Strength of non-prestressed conventional reinforcement in tension = 347.83MPa.

**Check  $(A_s^* f_{su}^*) / (0.85 f'_c b)$  is not greater than the compression flange thickness “t<sub>top</sub>”:**

**$(A_s^* f_{su}^*) / (0.85 f'_c b) = 268.99\text{mm} < t_{top} = 402.50\text{mm} \dots\dots\dots \text{OK!}$**

**Then,**

**$\phi M_n = 37,054.46\text{KNm} > M_d = 30,289.79\text{KNm} \dots\dots\dots \text{OK!}$**

**II. AT SUPPORT**

$\phi$  = Strength Reduction Factor (AREMA Article 17.15.1.b (1)) = 0.95,

$A_s^*$  = Area of Prestressing Steel = 33,626.14mm<sup>2</sup>,

$f_{su}^*$  = Average Stress in Prestressing Steel at Ultimate Load = 1,369.40MPa,

$d$  = Distance from extreme compression fiber to centroid of the Prestressing Force =  $h - (\bar{y} - e_p)$  = 1,494.77mm,

$d_t$  = Distance from the extreme compressive fiber to the centroid of the non-prestressed tension reinforcement (assume) = 2,400.00,

$\rho^*$  =  $A_s^*/(bd^*)$ , ratio of prestressing steel = 0.0045,

$\rho$  =  $A_s/(bdt)$  ratio of non-prestressed tension reinforcements = 0.0000,

$A_s$  = Area of Non-Prestressing Steel (provide 6 diameter 24 bars) = 0.00mm<sup>2</sup>,

$b$  = width of flange or width of rectangular member = 5,035.00mm,

$f'_c$  = Compressive Strength of Concrete at 28 days = 40.00MPa,

$f_{sy}$  = Yield Strength of non-prestressed conventional reinforcement in tension = 347.83MPa.

**Check  $(A_s^*f_{su}^*)/(0.85f'_c b)$  is not greater than the compression flange thickness " $t_{top}$ ":**

**$(A_s^*f_{su}^*)/(0.85f'_c b) = 268.99\text{mm} < t_{top} = 402.50\text{mm}$  ..... OK!**

**Then,**

**$\phi M_n = 59,387.84\text{KNm} > M_d = 34,472.50\text{KNm}$  ..... OK!**

**STEP 15: CHECK DUCTILITY LIMITS**

**I. MAXIMUM PRESTRESSING STEEL**

Prestressed concrete members shall be designed so that the steel is yielding as ultimate capacity is approached. In general, the reinforcement index shall be such that:

**$\rho^*f_{su}^*/f'_c$  .....  $\leq 0.36\beta_1$  for rectangular sections,**

**$A_{sr}f_{su}^*/b'df'_c$  .....  $\leq 0.36\beta_1$  for flanged sections,**

(AREMA Article 17.19.1).

Take  $\beta_1 =$  factor for concrete strength = 0.70 ..... AREMA Article 2.31.1(f).  
 Since  $(A_s f_{su}) / (0.85 f'_c b)$  is not greater than the compression thickness “ $t_{top}$ ”, the section is rectangular.

**Thus, at span and support (Rectangular Section)  $P^* f_{su} / f'_c = 0.15 \leq 0.25$  .....OK!**

## II. MINIMUM REINFORCEMENT

The total amount of prestressed and non-prestressed reinforcement shall be adequate to develop an ultimate moment at the critical section at least 1.2 times the Cracking Moment,  $M^*_{cr}$ .

$$\phi M_n \geq 1.2 M^*_{cr}$$

$$\text{Where, } M^*_{cr} = (f_r + f_{pe}) S_c - M_{d/nc} (S_c / S_b - 1)$$

Approximate values for  $M_{d/nc}$  and  $s_b$  shall be used for any intermediate composite sections. Where, beams are designed to be non-composite, substitute  $S_b$  for  $S_c$  in the above equation for the calculation of  $M^*_{cr}$ .

$$\text{Since the section is non-composite, } S_c = S_b \text{ so that } M^*_{cr} = (f_r + f_{pe}) S_b - M_{d/nc} (S_b / S_b - 1) = (f_r + f_{pe}) S_b$$

$f_{pe}$  = compressive stress in concrete due to effective prestress forces only (after allowance for all prestress losses) at extreme fiber of section where tensile stress is caused by externally applied loads.

$$f_{pe} = 15.97 \text{MPa (Maximum Compressive Stress)}$$

$f_r$  = modulus of rupture of concrete, as defined in Article 17.16.2.3 =  $0.623 (f'_{ci})^{1/2}$  for normal weight concrete.

$$f_r = 11.21 \text{MPa,}$$

$$S_b = 8.55 \text{E}+08 \text{mm}^3,$$

$$M^*_{cr} = 23,240.62 \text{MPa.}$$

**The requirement is  $\phi M_n \geq 1.2 M^*_{cr}$ :**

$\phi M_n$  = take the flexural strength of the section at span or at support whichever is minimum.

$\phi M_n = 37,054.46\text{KNm} \geq 1.2M_{cr}^* = 27,888.74\text{KNm}$  ..... OK!

**STEP 16: DESIGN FOR SHEAR**

Members subject to shear shall be designed so that

$V_u \leq \phi(V_c + V_s)$  ..... AREMA Article 17.21.1.3.

Where,

$\phi$  = the strength reduction factor = 0.90 for shear (AREMA Article 17.15.1.b(2),

$V_u$  = the factored shear force at the section considered,

$V_c$  = the nominal shear strength provided by concrete,

$V_s$  = the nominal shear strength provided by web reinforcement.

**Shear Strength provided by Concrete ( $V_c$ ):**

For more precise analysis the shear strength provided by concrete,  $V_c$ , shall be taken as the lesser of the values  $V_{ci}$  or  $V_{cw}$  ..... AREMA Article 17.21.2.2.

**I. Determine  $V_{ci}$ :**

$V_{ci} = 5 \times 104(f'_c)^{1/2}b'd + V_d + V_i \cdot M_{cr}/M_{max} \geq 220(f'_c b'd)^{1/2}$

Where,

$f'_c$  = Compressive Strength of Concrete at 28 days = 40.00MPa,

$b'$  = web width = 933.80mm,

$d$  = distance from extreme compression fiber to centroid of the prestressing force = 1,494.77mm (take at support),

$V_d$  = shear force at section due to unfactored dead load =  $V_g + V_{SDL} = 3,025.79\text{KN}$ ,

$M_{cr}$  = moment causing flexural cracking at section due to externally applied loads,

$M_{max}$  = maximum factored moment at section due to externally applied loads =  $M_u - M_g -$

$M_{SDL} = 25,779.35\text{KNm}$ ,

$V_i$  = factored shear force at section due to externally applied loads occurring simultaneously with  $M_{max} = V_u - V_g - V_{SDL} = 4,682.41\text{KN}$ .

$M_{cr}$  is computed by

$$M_{cr} = (I/y_t)(0.5*(f'_c)/2 + f_{pe} - f_d)$$

Where,

$I$  = moment of inertia about the centroid of the cross section =  $8.42E+11 \text{ mm}^4$ ,

$y_t$  = distance from centroidal axis of the section to extreme fiber in tension =  $625.23\text{mm}$ ,

$f'_c$  = Compressive Strength of Concrete at 28 days =  $40.00\text{MPa}$ ,

$f_{pe}$  = compressive stress in concrete due to effective prestress forces only =  $15.96\text{MPa}$ ,

$f_d$  = stress due to unfactored dead load =  $((M_g + M_{SDL})/S_b) = 19.91\text{MPa}$ .

Then,

$M_{cr} = -1,064.64\text{KNm}$ , and

$$V_{ci} = 5 \times 10^4 (f'_c)^{1/2} b' d + V_d + V_i * M_{cr} / M_{max} \geq 220 (f'_c b' d)^{1/2}$$

$$V_{ci} = 441,397,581.30\text{KN} \geq 220 (f'_c b' d)^{1/2} = 1,643.87\text{KN} \dots\dots\dots \text{OK!}$$

**II. Determine  $V_{cw}$ :**

$$V_{cw} = 10 \times 10^5 [(0.29(f'_c)^{1/2} + 0.3f_{pe}) b' d] + V_p \text{ but } d \text{ need not be taken less than } 0.8h.$$

Where,

$f'_c$  = Compressive Strength of Concrete at 28 days =  $40.00\text{MPa}$ ,

$f_{pe}$  = compressive stress in concrete due to effective prestress forces only =  $15.96\text{MPa}$ ,

$b'$  = web width =  $933.80\text{mm}$ ,

$d$  = distance from extreme compression fiber to centroid of the prestressing force =  $1,494.77\text{mm}$  (take at support),

$V_p$  = vertical component of effective prestress force at section = taking the slope of the tendon at supports to be  $16^\circ = P_{se} * \text{Sin}16^\circ = 10,221.85\text{KN}$ .

**Thus,**

$$V_{cw} = 9,241,234,504.33\text{KN}.$$

$V_c$  shall be the lesser of  $V_{ci}$  or  $V_{cw}$  ..... AREMA Article 17.21.2.2.

$$\text{Thus, } V_c = 441,397,581.30\text{KN} > V_u = 7,708.20\text{KN} \dots\dots\dots \text{OK!}$$

Since the shear strength provided by concrete  $V_c > V_u$ , web reinforcement is not required.

However; minimum shear reinforcement must be provided.

### III. MINIMUM SHEAR REINFORCEMENT

The minimum area of web reinforcement shall be  $A_v = (0.345b's)/f_{sy}$  ..... AREMA Article 17.21.3.3.

Use bars = 10.00mm,

$A_v = 314.00\text{mm}^2$  (Note:  $A_v = 0.25 \cdot 3.14 \cdot (\text{diameter})^2 \cdot 4$  ..... (4 because two webs),

$f_{sy} = 347.83\text{MPa}$ ,

$b' = 933.80\text{mm}$ ,

Then,  $s = 339.01\text{mm}$ .

Provide Diameter = 10mm Closed Bars @  $S = 330.00\text{mm}$ .

$A_v = 314.00\text{mm}^2 \geq \text{Minimum } A_v = 310.28\text{mm}^2$  ..... OK!

### STEP 17: CHECK DEFLECTIONS

Since the stress limits calculated in steps 9, 10, and 11 are within the tolerable range under the action of all the loadings considered, there is no need to check for the deflections.

### STEP 18: CHECK BEARING STRESS UNDER THE ANCHORAGE STEEL PLATE

The effective concrete bearing compressive strength  $f_b$  used for design shall not exceed

$f_{br} \leq 0.7f'_{ci} (A/A_{gb})^{0.5}$  but  $f_{br} \leq 2.25f'_{ci}$  ..... AREMA Article 17.22.7.2.

Where,

$f'_{ci}$  = concrete compressive strength at the time of prestressing,

A = the maximum area of the portion of the supporting surface that is geometrically similar to the loaded area and concentric with it,

$A_{gb}$  = gross area of the bearing plate.

Notes for the Placement of the Cable Ducts:

- 1.) Ducts for multiple wire, strand, or bar tendons shall have an inside cross sectional area not less than 2 times the net area of tendons.....AREMA Article 17.5.5(c).

2.) Clear distance between post-tensioning ducts or trumpets at each end of a member shall not be less than 1-1/2 in. (40 mm).....AREMA Article 17.5.1(b).

We have:

$f_{ci} = 40.00\text{Mpa}$ ,

Number of Strands = 240,

Single Strand Area =  $140.00\text{mm}^2$ ,

Total Strand Area =  $33,626.14\text{mm}^2$ ,

Prestressing Force,  $P = 43,781.23\text{KN}$ .

Use ducts with inner diameter = 80.00mm and outer diameter = 85.00mm,

Inner Area of Cable Ducts =  $5,024.00\text{mm}^2$ ,

Minimum Number of Ducts = 7,

Use Cable Ducts = 8 (Distribute uniformly on both sides of the bridge cross section).

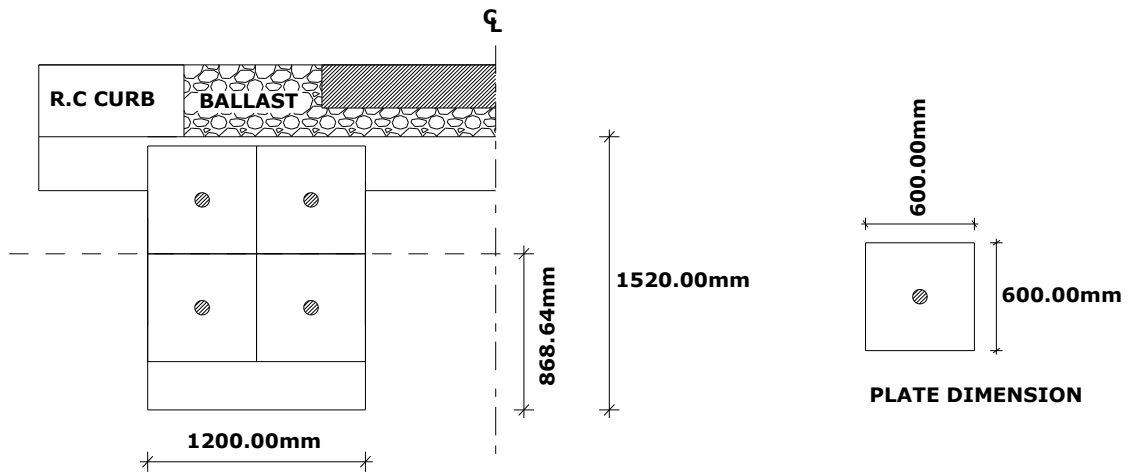

FIGURE A28: BEARING PLATES ARRANGEMENT (T-GIRDER)

Use 2 Anchorage Bearing Plate with the following dimensions:

Bearing Plate Width = 400.00mm,

Bearing Plate Length = 2,200.00mm,

Concentric Area Width = 400.00mm,

Concentric Area Length = 2,200.00mm,



$A_{gb} = 880,000.00\text{mm}^2$ , and  
 $A = 880,000.00\text{mm}^2$ .

Then,

$f_{br} = 25.20\text{MPa}$  (Allowable bearing stress under the anchorage device).

**$f_{br} = 25.20\text{MPa} \leq 2.25f'_{ci} = 81.00\text{MPa}$  ..... OK!**

Check actual bearing stress:

Prestressing Force,  $P = 43,781.23\text{KN}$ ,

Anchorage Devices = 2,

Bearing Plate Area =  $880,000.00\text{mm}^2$ ,

**Actual Bearing Stress =  $24.88\text{MPa} \leq f_{br} = 25.20\text{MPa}$  ..... OK!**

**STEP 19: DETERMINE THE REINFORCEMENT REQUIRED TO RESIST THE BURSTING STRESSES**

In order to determine the reinforcement required to resist the bursting forces in the anchorage zones, we need to find the acting force using the strut-and-tie model shown below.

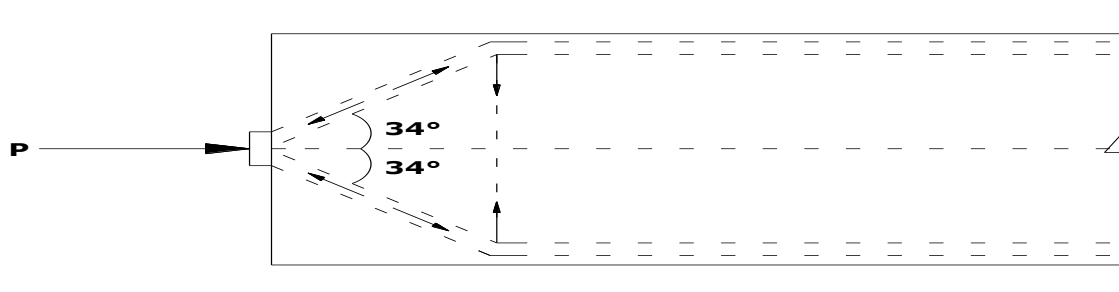

FIGURE A29: STRUT-AND -TIE MODEL OF THE ANCHORAGE ZONE (T-GIRDER)

Maximum Prestressing Force acting on each end anchorage device =  $18,108.97\text{KN}$ ,

**Then, Bursting Force = (Prestressing Force) X  $(\tan 34^\circ) = 14,755.83\text{KN}$ .**

Use closed mild reinforcements with Yield Strength  $f_{sy} = 347.83\text{MPa}$ ,

Required Reinforcement =  $(\text{Bursting Force}) / (f_{sy}) = 42,423.00\text{mm}^2$ .

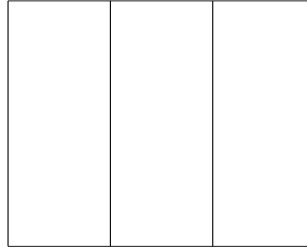

FIGURE A30: REINFORCEMENT PATTERN FOR BURSTING FORCES (T-GIRDER)

Using 10.00mm bars with the pattern shown above:

$$A_v = 314.00\text{mm}^2 \text{ (Note: } A_v = 0.25 * 3.14 * (\text{diameter})^2 * 4 \text{ ..... 4 because 4 legs),}$$

Number of Bars = 135.

Thus, provide 135 diameter 10mm closed bars, with the pattern shown above, around each anchorage device to resist bursting forces. These bars should be placed uniformly over a length equal to the greatest lateral dimension of the effective end-block dimension, which is 2805mm. Alternatively, anchorage devices which are fabricated with spiral reinforcements to resist these bursting forces can be also used if available.

**STEP 20: CONSTRUCTION COST ESTIMATION OF THE BRIDGE SUPERSTRUCTURE**

This involves quantifying the volume of bridge superstructure work items in order to estimate the approximate construction costs for each span combination. In this regard, the volume of C50 Concrete, form work to Concrete, the lengths of the prestressing tendons, and mild reinforcement bars shall be taken into consideration using the unit prices assumed to estimate the construction cost.

TABLE A12: CONSTRUCTION COST ESTIMATE FOR T-GIRDER WITH SPAN COMBINATION 33.00 - 34.00 - 33.00m					
ITEM	WORKS DESCRIPTION	UNIT	QUANTITY	UNIT PRICE	AMOUNT (BIRR)
1	C50 CONCRETE	m <sup>3</sup>	428.17	4,000.00	1,712,685.80
2	FORM WORK TO CONCRETE	m <sup>2</sup>	837.96	400.00	335,183.03
3	DIAMETER 15.24mm TENDONS	m	19,297.40	400.00	9,999,713.79
4	ALL MILD REINFORCEMENT BARS	Kg	7,901.36	40.00	316,054.35
<b>TOTAL AMOUNT (BIRR)</b>					<b>12,363,636.97</b>

## I. REINFORCEMENT DETAIL FOR T-GIRDER

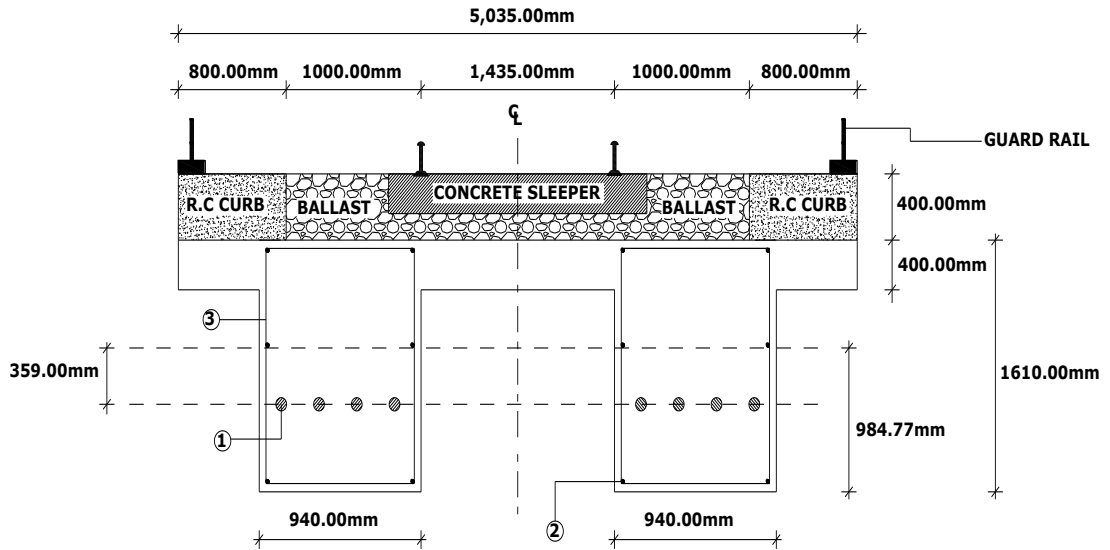

**LEGEND:**

- ① DUCTS (INNER DIAMETER = 80.00mm, WITH TOTAL TENDONS No. =240)
- ② MILD REINFORCEMENT (No. =12, LENGTH = 101.60m)
- ③ WEB SHEAR REINFORCEMENT (S=335mm, No. =300, LENGTH = 5.00m)

FIGURE A31: T-GIRDER REINFORCEMENT DETAIL AT SPAN

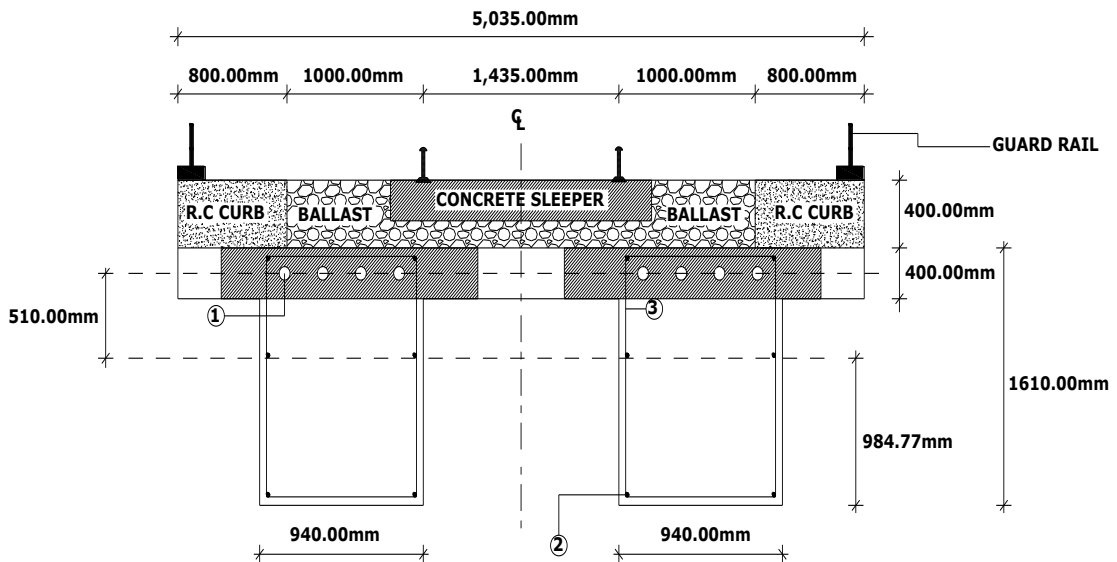

**LEGEND:**

- ① DUCTS (INNER DIAMETER = 80.00mm, WITH TOTAL TENDONS No. =240)
- ② MILD REINFORCEMENT (No. =12, LENGTH = 101.60m)
- ③ WEB SHEAR REINFORCEMENT (S=335mm, No. =300, LENGTH = 5.00m)

FIGURE A32: T-GIRDER REINFORCEMENT DETAIL AT SUPPORT

## REFERENCES

1. AASHTO, AASHTO LRFD Bridge Design Specifications, 1<sup>st</sup> ed., American Association of State Highway and Transportation Officials, Washington, D.C., 1994.
2. ACI-ASCE Committee 343 (1988). Analysis and Design of Reinforced Concrete Bridge Structures, American Concrete Institute, Detroit, MI.
3. Addis Ababa Light Rail Transit Project, Construction Drawing Design, Chapter IX, Elevated Structures, Book 28, Section Reference Drawing Volume 5 (September 2013).
4. ASIAN JOURNAL OF CIVIL ENGINEERING (BUILDING AND HOUSING) VOL. 12, NO. 1 (2011) PAGES 39-59.
5. American Concrete Institute (ACI), Design Hand Book Volume 2; Columns, ACI, 1990.
6. American Railway Engineering and Maintenance-of-Way Association, 2010, Manual for Railway Engineering.
7. A. Mohammed, A. Abul, A. Husein (March 2012), Optimization of Continuous Post-Tensioned Concrete Bridge Girders of Non-Uniform Depth.
8. Booker Associates Inc. and Kansas Department of Transportation (April 1998), Post-Tensioned Concrete Haunched Slab Bridge Standards.
9. Bridge Engineering Hand Book, Ed. Wai-Fah Chen and LianDuan, Boca Raton: CRC Press, 2000.
10. Bulletin of the New Zealand National Society for Earthquake, Vol. 22, No. 1, March 1989.
11. Caltrans (1990). "Selection of Type," Bridge Design Aids, California Department of Transportation, Sacramento, CA, pp. 10–21 to 10–29.
12. Design of Highway Bridges: An LRFD Approach, Second Edition. Richard M. Barker and Jay A. Puckett © 2007 John Wiley & Sons, Inc. ISBN: 978-0-471-69758-9.
13. Dr. Bijan O. Aalami (Dec 1998), Hyperstatic (Secondary) Actions In Prestressing And Their Computations, Pti Technical Notes.
14. Dr. C. Caprani (2006/7), Chartered Engineer, Civil Engineering Design (1), Prestressed Concrete.

15. DYWIDAG Bonded Post – Tensioning Systems using Strands (August 2006).
16. ETHIOPIAN BUILDING CODE STANDARD FOR STRUCTURAL USE OF CONCRETE (1995).
17. <http://www.alibaba.com/showroom/prestressing-strand-prices.html>.
18. ICE Manual of Bridge Engineering, 2<sup>nd</sup> Edition, 2008, Institute of Civil Engineers.
19. IJREAT, International Journal of Research in Engineering & Advanced Technology, Volume 1, Issue 2, April-May, 2013 ISSN: 2320 – 8791.
20. John P. Miller (2012), Fundamentals of Post-Tensioned Concrete Design for Buildings.
21. Kenneth B. Bondy (2003), Moment Redistribution: Principles and Practice using ACI 318-02.
22. Mary Beth D. Hueste, John B. Mander, and Anagha S. Parkar (2011) Texas Transportation Institute: Continuous Prestressed Concrete Girder Bridges.
23. NDOT STRUCTURES MANUAL (September 2008), Chapter 15: Steel Structures.
24. PennDOT (1993). “Selection of Bridge Types,” Design Manual—Part 4, Vol. 1, PartA: Chapter 2, Pennsylvania Department of Transportation, Harrisburg, PA.
25. Portland Cement Association (Continuous Concrete Bridges, 2<sup>nd</sup> Edition).
26. Prestressed Concrete Design (2003), 2<sup>nd</sup> Edition, M.K. Hurst MSc, DIC, MICE, MStruct.E.
27. SAP2000 Version 14.0.0© Copyright Computers and Structures, Inc., 2009.
28. Steel Bridge Design Handbook Design Example 1: Three-Span Continuous Straight Composite Steel I-Girder Bridge Publication No. FHWA-IF-12-052 - Vol. 20, November 2012.
29. The Design of Prestressed Concrete Bridges, Concepts and Principles, Robert Benaim.
30. Teresa Peter (2013), International Journal of Engineering Research and Applications, Determination of Hyperstatic Moments in Post-Tensioned Concrete Flat Slab.
31. Troitsky, M. S. (1994). Planning and Design of Bridges, Wiley, New York.
32. US Department of Transportation, Federal Highway Administration, Post Tensioning Tendon Installation and Grouting Manual: FHWA-NHI-13-026 Version 2.0 (May 2013).
33. VSL INTERNATIONAL LTD. (1991), Bern, Switzerland, Detailing for Post-Tensioning.