

OPTIMAL DESIGN FOR PRESTRESSED CONCRETE BOX GIRDER BRIDGE

Samuel HaileMichael WeldeHawariat

“A thesis submitted to the School of Graduate Studies of Addis Ababa
University in partial fulfillment of the requirements for Degree of MSc. in
Structural Engineering

June 6, 2002
Addis Ababa
Ethiopia

ACKNOWLEDGEMENT

The assistance my advisor Dr. Shifferaw Taye while developing the thesis, Biruk Birhane for provision of computers, Anketse Solomon and Aregash Fikru with typing the manuscript are gratefully acknowledged.

CONTENTS

	page
ABSTRACT	1
Chapter One theory of pre stressed concrete:-	3
1.1 Introduction	3
1.2 Advantage and disadvantage of pre stressed concrete	4
1.3 Reinforced concrete verses pre stressed concrete	5
1.4 Pre stressing systems	5
1.5 Loss of pre stress	6
1.5.1. Loss due to elastic shortening (ES)	7
1.5.2. Loss Due to Creep in Concrete	8
1.5.3. Loss Due to Shrinkage in Concrete	9
1.5.4. Loss Due to Relaxation of Steel	10
1.5.5. Frictional Loss in Post-Tensioned Members	11
1.5.6. Total Amount of Losses	12
1.6 Stress analysis for pre stressed concrete section	13
1.6.1 Stresses in concrete due to pre stress	13
1.6.2 Stresses in concrete due to loads	15
1.6.3 Pressure line method for determination of stress a concrete	15
1.7 Analysis of pre stressed concrete section for ultimate moment capacity	16
1.8 Design of a pre stressed concrete section	20
1.8.1 Elastic design	20
1.8.2 Ultimate design	27
Chapter Two Application of pre stressed concrete on bridge	29
Chapter Three Optimization theory	31
3.1. Engineering application of optimization	31
3.2. Statement of an optimization	32
3.3. Classification of optimization problem	34
Chapter Four Optimization methods	32

4.1. Linear programming method	35
4.1.1. Problem formulation	35
4.1.2. Method of solution	38
4.2. Non-linear programming	42
4.2.1. Methods for unconstrained minimization	50
4.2.2. Methods for constrained minimization	54
4.2.1.1. Methods for feasible direction	55
4.2.1.2. Penalty function methods	60
Chapter Five Formulation	62
5.1 Design variable	62
5.2 Constraints	63
5.2.1. Normal stress constraints	63
5.2.2. Ultimate strength constraints	68
5.2.3. Maximum pre stressing steel constraint	74
5.2.4. Minimum pre stressing steel constraint	75
5.2.5. Deflection Constraint	76
5.2.6. Transverse bending strength constraint	77
5.2.7. Design or side constraints	80
5.3 Objective function	81
Chapter Six Numerical examples	82
APPENDIX	
Flow Chart	94
Program Source Code	130

ABSTRACT

This thesis concerned with optimization of simply supported prestressed concrete box girder bridge. Usually, the design of prestressed concrete bridges is done based on codes on prestressed concrete bridges. The code requirement is generally concerned with the safety of the structure in its lifetime. Apart from satisfying the code requirement, the design should be economically chosen. For a given condition, there might be a large number of alternatives that satisfy the requirements imposed by codes. But the designer must be in position to choose the one, which is optimal against certain measure of optimality. Therefore, the designers have to do some optimization to arrive at such design.

The objective of this thesis work is to show how the optimal design of a prestressed concrete box-girder bridge can be obtained. It will established a general relationship among different design variables at optimum and will recommend a simple procedure to identify an the optimum design.

The presentation is divided in to six chapters. In chapter one, a detail discussion on the theory of prestressed concrete is presented. Great emphasis is given for analysis of sections for flexure both in elastic and plastic ranges. It also explains the usual trends to be followed in the design of a pre stressed concrete section under service and over loads.

In chapter two, application of pre stressed concrete on bridge is discussed. Conditions favoring pre stressed concrete application for such type of structural systems

Chapter three discusses about optimization theory and general formulation of an optimization problem. Emphasis will be given numerical optimization theory and techniques.

Chapter four deals with the methods used to solve an optimization problem. An extended complete coverage is given on linear programming and feasible direction methods, as they will be used later in chapter six to solve an optimal design problem for box-girder bridge.

In chapter five, an optimal design problem is formulated for simply supported rectangular box-girder bridge based on AASHTO 96 Code.

In chapter six, the optimal design problem formulated in (chapter five) is solved for 40m span bridges using a Fortran program written for the method of Feasible Direction. The program is developed for this particular purpose. Concluding remark is also given

The source code of developed program along with a flow chart outlining the program logic to this work is included in an appendix.

CHAPTER ONE

Theory of Prestressed Concrete

1.1 Introduction

Prestressing can be defined as the application of pre-determined force or moment to a structural member in such a manner that the combined internal stresses in the member resulting from this force or moment and any anticipated condition of external loading will be confined within specific limits.

In general, prestress involves the imposition of stresses opposite in sign to those, which are caused by the subsequent application of workshop loads. For instance for prestressing wire placed eccentrically, the force in tendon produce an axial compression and hogging moment in the beam. While under service loads the same beam will develop sagging moments. Thus, it is possible to have the entire section in compression when service loads are imposed on the beam as shown in Fig 1.1. This is the main advantage of prestressed concrete. It is well known that reinforced concrete cracks in tension. But there is no cracking in fully prestressed concrete since the entire section is in compression. Thus, it can be said that prestress provides a means for efficient usage of the concrete cross-section in resisting the external loads.

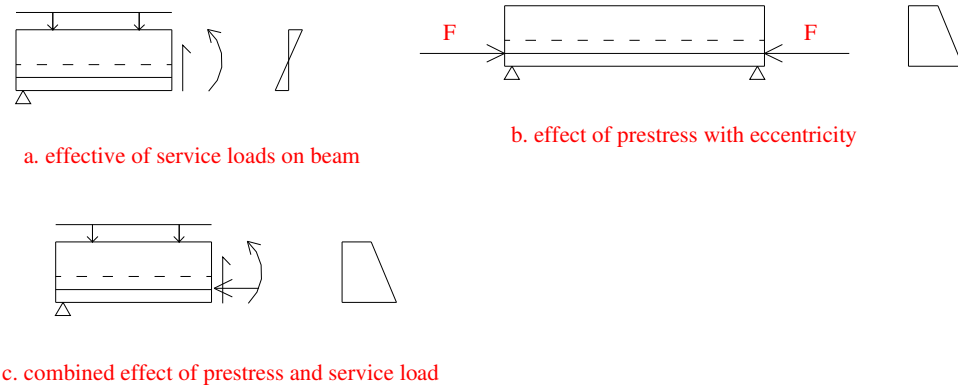

Fig. 1.1

1.2 Advantage And Disadvantages Of Prestressed Concrete

The most important feature of prestressed concrete is that it is free of cracks under working loads and it enables the entire concrete section to take part in resisting moments. Due to no-crack condition in the member, corrosion of steel is avoided when the structure is exposed to weather condition.

The behavior of prestressed concrete is more predictable than ordinary reinforced concrete in several aspects. Once concrete cracks, the behavior of reinforced concrete becomes quite complex. Since there is no cracking in prestressed concrete, its behavior can be explained on a more rational basis.

In prestressed concrete structures, sections are much smaller than that of the corresponding reinforced concrete structure. This is due to the fact that dead load moments are counterbalanced by the prestressing moment resulting from prestressing forces and shear resisting capacity of such section is also increased under prestressing. The reduced self-weight of the structure contribute to further reduction of material for foundation elements.

Other feature of prestressed concrete is its increased quality to resist impact, high fatigue resistance and increased live load carrying capacity. Prestressed concrete is most useful in constructing liquid

containing structures and nuclear plant where no leakage is acceptable and also used in long span bridges and roof systems due to its reduced dead load.

On the other hand, prestressed concrete also exhibit certain disadvantages

Some of the disadvantages of prestressed concrete construction are:

- i) It requires high strength concrete that may not be easy to produce.
- ii) It uses high strength steel, which might not be locally available

- iii) It requires end anchorage, end plates, complicated formwork
- iv) Labor cost may be greater, as it requires trained labor
- v) It calls for requires better quality control

Generally however prestressed concrete construction is economical , as for example a decrease in member section s result in decreased design loads an economical substructure.

1.3 Reinforced Concrete Versus Prestressed Concrete

Both reinforced concrete and prestressed concrete employ two materials concrete and steel. But high strength concrete and steel are used in prestressed concrete. Although they employ the same material, their structural behavior is quite different.

In reinforced concrete structures, steel is an integral part and resists force of tension which concrete cannot resist. The tension force develops in the steel when the concrete begin to crack and the strains of concrete are transferred to steel through bond. The stress in steel varies with the bending moment. The stress in steel should be limited in order to prevent excessive crack of concrete. In fact the steel acts as a tension flange of a beam.

In prestressed concrete, on the other hand the steel is used primarily for inducing a prestress in concrete. If this prestress could be induced by other means, there is little need of steel. The stress in

steel does not depend on the strain in concrete; there is practically no variation in the stress in steel along the length of the beam. There is no need to limit the stress in steel in order to control cracking of concrete. The steel does not act as a tension flange of a beam.

1.4 Prestressing Systems

The prestress in concrete structure is induced by either of the two processes. Pre tensioning and post tensioning

Pre-tensioning is accomplished by stressing wires, or strands called tendon to a pre-determined amount by stretching them between anchoring posts before placing the concrete. The concrete is then placed and the tendons become bonded to the concrete throughout their length. After the concrete has hardened, the tendon will be released from the anchoring posts. The tendon will tend to regain their original length by shortening and in this process they transfer a compressive stress to the concrete through bond. The tendons are usually stressed by hydraulic jacks.

The other alternative is *post-tensioning*. In post-tensioning, the tendons are stressed after the concrete is cast and hardened to certain strength to withstand the prestressing force. The tendon are stressed and anchored at the end of the concrete section. Here, the tendons are either coated with grease or bituminous material or encased with flexible metal hose before placing in forms to prevent the tendons from bonding to the concrete during placing and curing of concrete. In the latter case, the metal hose is referred to as a sheath or duct and remains in the structure. After the tendons are stressed, the void between tendon and the sheath is filled with grout. Thus the tendons are bonded with concrete and corrosion is prevented.

Post-tension prestressing can be done on site. This procedure may be very important for certain cases. For large spans elements in building or bridges, the method may not be feasible as it requires transporting such members from precasting plant to a job site.

In post-tensioning it is necessary to use some device to attach or anchors ends of tendon's to the concrete section. These devices are called end anchorage.

The main difference between the two pre stressing system is:-

- i) Pre tensioning is mostly used for small member, whereas post-tensioning is used for larger spans.

- ii) Post- tensioned tendon can be placed in the structure with little difficulties in smooth curved profile. Pre-tensioned tendon can be used for curved profile but need extensive plant facilitates
- iii) Pre-tensioning system has the disadvantage that the abutment used in anchoring the tendon has to be very strong and cannot be reused until the concrete in the member has sufficiently hardened and removed from bed.
- iv) Lose of prestress in pre- tensioning is more pronounced than that of post- tensioning.

1.5 Loss Of Prestress

It is difficult to measure the amount of prestress actually present in a prestressed concrete member. Only, the total force in tendon at the time of prestressing can be conveniently determined. Due to several factor to be presented subsequently the initial prestressing force in tendons may be altered with time. There will be loss of stresses in the steel.

The most common type losses that will occur in a prestressed concrete member are explained in the next subsections.

1.5.1. Loss Due To Elastic Shortening (ES)

As the prestressed is transferred to the concrete the member shorten and the prestressing steel shorten with it. Therefore, there is a loss of prestress in the steel. The loss of prestress due to this elastic shortening can be easily computed. Consider, a pre-tensioned simple beam. First, let's assume the tendon profile is straight and at c.g.c level. (No bending).

The strain in concrete may be expressed by

P is the total prestressing force just after transfer

$$\epsilon_c = \frac{P}{A_c \times E_c} \quad (1-1a)$$

The strain in steel may be expressed by

$$\epsilon_s = \frac{P_o - P}{A_s \times E_s} \quad (1-1b)$$

P is total prestressing force before transfer

Equating (1-1a) and (1-1b) gives

$$\begin{aligned} \epsilon_c &= \epsilon_s \\ \text{or, } \frac{P}{A_c \times E_c} &= \frac{P_o - P}{A_s \times E_s} \\ \text{or, } \frac{p_o}{p} &= \frac{A_c + m \times A_s}{A_c} = \frac{A_g}{A_c} \end{aligned}$$

The loss of pre stress $\Delta\sigma$ is

$$ES = \Delta\sigma = \frac{P_o - P}{A_g} = \frac{m \times P}{A_c} = \frac{m \times P_o}{A_g}. \quad (1-1c)$$

where m = modular ratio

Loss of prestress due to elastic shortening of concrete, whether the prestressing force is applied at centroid of the section or not, can be given by

$$ES = \frac{E_s}{E_{ci}} \times f_{cir} \quad (1-2)$$

where f_{cir} is the stress in concrete at c.g.s level due to prestressing force at transfer (P_o) and due to dead load moment at the section being considered.

In post tensioning, the tendons are not usually stretched simultaneously. Moreover, the first tendon that is stretched is shorten by subsequent stretching of all other tendon. Only the last tendon is not shorten by any subsequent stretching. An average value of strain change can be computed and equally applied to all tendons.

1.5.2. Loss Due To Creep Of Concrete

Creep is the property of concrete by which it continue to deform with time under sustained load at unit stresses within the accepted elastic range. This inelastic deformation increase at decreasing rate during the time of loading and its magnitude may be several times larger than that of the short term elastic deformation. The strain due to creep varies with the magnitude of stress. It is a time dependent phenomena. Creep of concrete result in loss in steel stress.

The loss of prestress due to creep of concrete may be computed as follows.

Creep coefficient is defined as

$$\theta = \frac{\epsilon_{cp}}{\epsilon_c} \quad (1-3a)$$

where ϵ_{cp} is creep strain

ϵ_c is initial strain in concrete

Elastic strain in concrete at c.g.s level is given as

$$\epsilon_c = \frac{\sigma_{cs}}{E_c}$$

or $\epsilon_{cp} = \theta \times \frac{\sigma_{cs}}{E_c}$

where σ_{cs} - Stress in concrete at c.g.s level due to sustained load

The strain in concrete at c.g.s levels due to creep equals the decrease in strain of steel.

$$\epsilon_{cp} = \epsilon_s = \frac{\Delta\sigma}{E_s}$$

or $\frac{\Delta\sigma}{E_s} = \frac{\theta \times \sigma_{cs}}{E_c}$

or $\Delta\sigma = m \times \theta \times \sigma_c$ (1-3b)

where m –modular ratio

The value of the creep coefficient will take different value depending on the age of concrete at loading to account the variation of modulus of elasticity of concrete with time. values to 2.2, 1.6 or 1.1 could be assumed for age of concrete at loading 7 days, 28 days or 1 year respectively[2]. It takes almost one year to develop full creep strains; therefore, only stresses of permanent nature should be used to compute creep. Stresses due to dead load and pre stress should be considered to compute creep. In pre-tensioned member, prestress loss due to creep is higher than post-tensioned member because, in the former, the prestress is imposed when the concrete is in its early stage of curing.

1.5.3. Loss due to shrinkage of concrete

Shrinkage in concrete is a contraction due to drying and chemical changes. It is dependent on time and moisture condition but not on stress. The shrinkage strain varies due to several factors and may be range from 0.0000 to 0.0010 and in some instant beyond. At one extreme if the concrete is stored under water or under very wet conditions, the shrinkage may be insignificant. There may ever be expansion for some types of aggregates and cements. At the other extreme, for a combination of certain cements

and aggregates and with the concrete stored under very dry conditions, shrinkage values as high as 0.0010 can be expected [1].

The amount of shrinkage varies widely, depending on the individual conditions. For the propose of design, an average value of shrinkage strain would be about 0.0002 to 0.0006 for usual concrete mixtures employed in prestressed construction.

As explained above, shrinkage of concrete is influenced by many factors but in this work the most important factors volumes to surface ratio, relative humidity and time from end of curing to application of prestress are considered in calculation of shrinkage losses. An average strain value of 550×10^{-6} mm/mm is taken in computational work. And modification factors will also be used to account the influence of the above-mentioned factors [2]

The loss of prestress due to shrinkage is given by

$$SH = \epsilon_{sh} \times \epsilon_s \quad (1-4)$$

where ϵ_{sh} – shrinkage strain

E_s – Modulus of elasticity of pre stressing steel

1.5.4. Loss due to relaxation of steel

Relaxation is assumed to mean the loss of stress in steel under nearly constant strain at constant temperature. It is similar to creep of concrete. Loss due to relaxation varies widely for different steels and its magnitude may be supplied by the steel manufactures based on test data. This loss is generally of the order of 2-8% of the initial steel stress [2].

1.5.5 Frictional Losses in Post-tensioned Members

Frictional loss occurs only in post-tensioned member. The friction between tendons and the surrounding material is not small enough to be ignored. This loss may be considered partly to be due to length effect (wobble effect) and party to curvature effect. In straight elements, it occurs due to wobble effect and in curved ones, it occurs due to curvature and wobble effects.

If angle of curve is α and P_1 is force on pulling end of the curve, then force P_2 on the other end of the curve, then force P_2 on the other end of the curve, as shown in Fig 1.2, is given as [2]

$$P_2 = P_1 \times e^{-\alpha \times u}$$

Similarly, the relation between P_1 and P_2 due to length effect (wobble effect) is given as [2]

$$P_2 = P_1 \times e^{-K \times L}$$

The combined effect is

$$P_2 = P_1 \times e^{-(\alpha \mu + K \times L)} \quad (1-5)$$

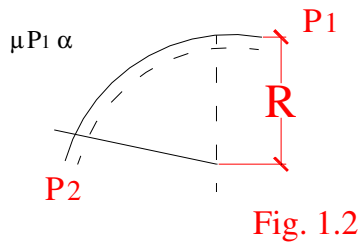

where μ = Coefficient of friction

K = Wobble friction coefficient per unit length of cable

$\alpha = L/R$, length of the curve divided by the radius of curvature

P_1 = Jacking force

The value of μ and K for different type of cables can be read from Codes

1.5.6 Total Amount of Losses

The total amount of prestressed losses is given by the cumulative figure of losses value outlined so far. It is useful in evaluating the effective prestresses. The total amount of losses to be assumed in design will depend on the basis on which initial prestress is measured. Depending on the definition of initial prestress, the amount of losses to be deducted will vary accordingly. If the jacking stress minus the anchorage loss is taken as the initial prestress, then the total losses will include the elastic shortening, creep and shrinkage in concrete plus relaxation of steel. This is the most common practice. On the other hand, if the jacking stress itself is taken as initial prestress, the anchorage losses should be included in the total losses.

For post-tension member, for points far away from the jacking end, frictional loss should be deducted in effective prestress calculation. But, sometimes, the tendons are stressed temporarily beyond normal jacking stress to compensate for the losses from anchorage and friction. In such case the anchorage and frictional losses may be left out.

The magnitude of all losses other than friction and anchorage are usually estimated in percent of initial pre stress. For average steel and concrete properties cured under average air conditions, the value given in table 1.1 could be taken as representative values [2].

Table 1.1

	Pre tensioning (%)	Post-tensioning (%)
Elastic Shortening	4	1
Creep of concrete	6	5
Shrinkage of concrete	7	6
Steel relaxation	8	8
Total	25	20

1.6 Stress Analysis for Prestressed Concrete Section

Differentiation can be made between the analysis and design of prestressed sections. By analysis is meant the determination of stresses in concrete and steel, while the form and size of the section are already given or assumed. This is obviously a simple operation compared to the design of the section, which involve the choice of suitable section out of many possible shapes and dimensions. In practice, it is often necessary to perform the process of design when assuming a section, and then to analyze the assumed section. But for the purpose of this study, the reversal of order is desirable for easier understanding the subject matter. In this section, the analysis of section for flexure is discussed.

The sign convention is used in the analysis is positive stresses are taken as compressive and negative stresses are taken as tensile stresses.

1.6.1 Stresses in concrete due to prestress

Stresses in concrete due to prestress are usually computed by an elastic theory. Consider the prestress force F , it can be the initial or final prestress. If the prestress is applied at the center of the cross-section, the stress in concrete is given by

$$f = F/A$$

where A is the area of the concrete

For pre tensioned member, when the prestress in steel is transferred from bulk head to the concrete, the force that was resisted by bulkhead is transferred to both steel and concrete in the member. This is equivalent to the application of an opposite force F_i to the member. Using the transformed section method [1], the compressive stress produced in the concrete is-

$$f_c = \frac{F_i}{A_c + n \times A_s} = \frac{F_i}{A_t} \quad (1-6)$$

A_c = net concrete area

While that induced in the steel is

$$\Delta f_s = n \times f_c = \frac{n \times F_i}{A_c + nA_s} = \frac{n \times F_i}{A_t} \quad (1-7)$$

which indicate the reduction of prestress in the steel immediately after transfer. In practice, the reduction in the steel stress is considered as a loss resulting from elastic shortening of the concrete and this is estimated by

$$\Delta f_s = \frac{n \times F_i}{A_c}$$

or

$$\Delta f_s = \frac{n \times F_i}{A_g} \quad (1-8)$$

where A_g is the gross area

The high strength steel used for prestressing require small area for tensile steel as result there will not be significant difference between A_c and A_g .

After the transfer of prestress, the loss due to creep and shrinkage in concrete should be carried out on basis of the transformed section. But again, this is rarely done in practice. Instead, an approximate percentage of prestress loss is assumed and the stress in the concrete is calculated simply using $f = F / A$ with the value of F estimated for given condition and the gross area is used as A .

For post-tensioned member, the same reasoning holds true. Suppose that, there are several tendons in the member prestressed in succession. Every tendon that is tensioned becomes, part of the section after grouting. So the effect of tensioning any subsequent tendon on previous tensioned tendon should be calculated on basis of transformed section. Theoretically, there will be a different transformed section after tensioning every tendon. However, such refinement is not justified and the usual procedure is simply to use $f = F / A$, with F based on the initial prestressed in the steel.

For a prestressing force F applied to a concrete section with an eccentricity e , the prestress is resolved in to two components a concentric force F through the centroid and a moment $F \times e$. Using elastic formula the stress at any point due to moment $M = F \times e$ is given by

$$f = \frac{M \times y}{I} = \frac{F \times e \times y}{I} \quad (1-9)$$

Then the resultant stress at a particular level y unit from the neutral axis becomes:

$$f = \frac{F}{A} \pm \frac{F \times e \times y}{I} \quad (1-10)$$

Here also, for pre tensioned member, the force should be initial prestress and I should be moment of inertial of transformed section, and e should be measured from the centroid of the transformed section. But, in practice, this procedure is seldom followed. Instead, the gross or net concrete section is considered [1], and either the initial or the reduced prestressing force is applied. The error is negligible in most cases [1].

For post-tensioned member before being bonded, the prestressing force F to be used in computation is the initial prestress minus the estimated loss. For the value of I , either the net concrete section or the gross concrete section may be used. After the steel is bonded, the subsequent loss afterward should be based on the transformed section however. The net section or the gross section is used together with the reduced estimated prestress.[1]

1.6.2. Stresses In Concrete Due To Loads

The stresses produced by any external load as well as own weight of the member is given by elastic theory as:

$$f = \frac{M \times y}{I} \quad (1-11)$$

For a bonded member, the transformed section should be used. But, in practice, the gross section is used in computing moment of Inertia I . For un-bonded member the net concrete section has to be adopted [1].

Often, the resulting stresses due to prestress and loads are required. Instead of the separate value and the resultant stress is given by combining Eqs. 1-10 and 1-11 as follows

$$\begin{aligned} f &= \frac{F}{A} \pm \frac{F \times e \times y}{I} \pm \frac{M \times y}{I} \\ &= \frac{F}{I} \times \left(1 \pm \frac{e \times y}{r^2} \right) \pm \frac{M \times y}{I} \\ &= \frac{F}{I} \pm (F \times e \pm M) \frac{y}{I} \end{aligned} \quad (1-12)$$

Any of the three forms may be used which ever is convenient to be used

1.6.3 Pressure Line Method For Determination Of Stress In Concrete

In this method, the stresses in concrete are not treated as being produced by prestress and external moment separately, but are determined by assuming a center of pressure C in the concrete located at distance a from the center of prestress T in the steel such that.

$$T \times a = C \times a = M \quad (1-13)$$

where M is the externally applied moment

Most beam do not carry axial load, therefore C equals T and is located at a distance from T , $a = M/T$. Since the value of T is the value of F in a prestressed beam it is quite accurately known, thus the computation of a for a given M is simply a matter of static's. Once the center pressure C is located for a concrete section, the distribution of stress can be determined by elastic theory as follows:

$$\text{Since } C = T = F, \quad f = \frac{C}{A} \pm \frac{C \times e \times y}{I} = \frac{F}{A} \pm \frac{F \times e \times y}{I}$$

where e is the eccentricity of C , not of F

Following this approach, a prestress beam is considered similar to a reinforced concrete beam with the steel supplying the tensile force T and the concrete supplying the compressive force C . C and T together form a couple resisting external moment. The value of A and I to be used in the above formula should be the net section of concrete. If the tendons are bonded, the gross section could be used[1].

1.7 Analysis Of Prestressed Concrete Section For Ultimate Moment Capacity

The analysis of a prestress concrete section for ultimate moment capacity based on the simple principle of resisting couple in the section, as that of reinforced concrete section. At ultimate load, the couple is made of two forces, T' and C' , acting with a lever arm a' . The steel supplies the tensile force T' , and the concrete, the compressive force C' .

Before going any further with the method of analysis, let us first study the modes of failure of prestressed beam section. The failure of a section may start either in concrete or steel, and may end up in one or the other. The most general case is that of under reinforced section, where the failure starts with the excessive elongation of steel and ends up with the crushing of concrete. This type of failure

occurs in both prestressed and reinforced-concrete beams, when they are under reinforced. Only in rare instance may fracture of steel occurs in such beams; that happens; for example, when the compressive flange is restrained and possess higher actual strength. A relatively uncommon mode of failure is that of one reinforced section, where the concrete is crushed before the steel is stressed in to plastic range. Hence there is a limited deflection before rupture and a brittle mode of failure is obtained.

There is no sharp line of demarcation between the percentage of reinforcement for an overreinforced beam and that for an underreinforced one. The transition from one type to another takes place gradually as the percentage of steel varied . A sharp defination of ‘balanced condition’ can not be made since the steel used for prestressing doesn’t exhibit a sharp yield point. For materials presently used in prestressed work the reinforcement index, w_p , which approximate the limiting value to assure that the prestressed area A_{ps} will be slightly into its yield range [1]. For instance ACI code limit w_p as follow:-

$$w_p = \rho_p \times f_{su} / f'_c \leq 0.3$$

$$\rho_p = \frac{A_{ps}}{b \times d}$$

where f_{su} = the average steel stress at ultimate load

b = effective width of the beam

d = effective depth of the beam

f'_c = concrete strength

For under reinforced bonded beam, following ACI code, the steel is stressed to a stress level which approach its ultimate strength at the failure of the beam. For purpose practical design, It will be sufficiently accurate to assume that the steel is stressed to the stress level , f_{su} , given by ACI code as follows:-

$$f_{su} = f_s \times (1 - 0.5 \rho_p \times \frac{f_s}{f'_c})$$

Provided that the effective prestressed f_{se} is not less than $0.5 f_s$.

The computation of the ultimate moment capacity is a relatively simple matter can be carried out as follows:- Referring Fig (1.3) the ultimate compressive force T’, thus,

$$C' = T' = A_s \times f_{su}$$

Let a' be the lever arm between C' and T' , then the ultimate moment capacity M_n is given by

$$M_n = T \times a' = A_s \times f_{su} \times a'$$

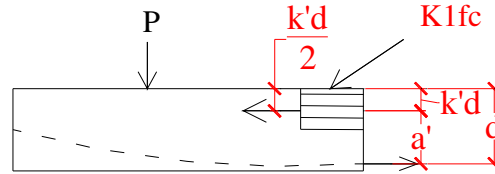

Fig. 1.3

ACI code gives $k_1 = 0.85$

$$K'd = a$$

The stress distribution in concrete is approximated by rectangular stress distribution like the reinforced concrete case [1].

The depth to the ultimate neutral axis $k'd$ is computed by

$$C' = k_1 f'_c k' b d$$

$$K'd = \frac{C'}{k_1 f'_c b} = \frac{A_s f_{su}}{k_1 f'_c b}$$

$$K' = \frac{A_s f_{su}}{k_1 f'_c b d}$$

Where $k_1 f'_c$ is the average compressive stress in concrete at rupture. Hence,

These formulas apply if the compressive flange has a uniform width b at failure

The level arm

$$a' = d - \frac{k'd}{2} = d \left(1 - \frac{k'}{2} \right)$$

Hence, the ultimate moment capacity is:-

$$M_n = A_s f_{su} d \left(1 - \frac{k'}{2} \right)$$

Using $k_1 = 0.85$ equation k' can be written as

$$k' = \frac{A_s f_{su}}{0.85 f_c' b d}$$

By substituting the expression for k' into eq. (M_n)

$$M_n = A_s f_{su} d \left(1 - \frac{A_s f_{su}}{2 \times 0.85 f_c' b d} \right)$$

For rectangular section for the compression area, we can let

$$\rho_p = A_s / b d$$

Then M_n becomes

$$M_n = A_s f_{su} d \left(1 - \frac{0.6 \rho_p f_{su}}{f_c'} \right)$$

Introducing, the strength reduction factor, ϕ ,

$$M_n = \phi \left[A_s f_{su} d \left(1 - \frac{0.6 \rho_p f_{su}}{f_c'} \right) \right]$$

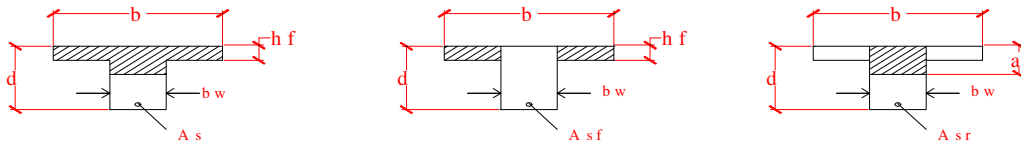

Fig. 1.4 flange section

flange part

web part

For flange sections (non rectangular compression zone) we may still use equation used in the previous case to estimate the steel stress f_{su} [1]. The total prestressing steel area A_s is divided in to two parts with A_{sf} developing the flanges and A_{sr} developing the web as shown in fig. 1.4

The ultimate moment is computed from two parts:- the flange part has the compression resultant force acting at the mid depth of flange, $h_f / 2$, and the arm of the couple is $(d - a/2)$. So the ultimate moment is given by

$$M_n = \phi \left[A_{sr} f_{su} \left(d - \frac{a}{2} \right) + 0.85 f_c' (b - b_w) h_f \left(d - \frac{h_f}{2} \right) \right]$$

$$A_{sr} = A_s - A_{sf}$$

$$A_{sf} = 0.85 f_c' (b - b_w) h$$

1.8 Design Of A Prestressed Concrete Section

The design of a prestressed concrete member involve selection and proportioning of a concrete section, determination of the amount of prestressing force and eccentricity for given section. The design is done based on strength (load factor design) and on behavior at service condition (Allowable stress design) at all load stages that may be critical during the life of the structure from the time the prestressing force is applied [3]. In this section the allowable stress design (Elastic design) and the load factor design (ultimate design) of a section for flexure is explained.

1.8.1 Elastic Design

This design method ensures stress in concrete not to exceed the allowable stress value. Both at transfer and under working load. For simple beam, this condition could be written as follows.

At transfer

At this stage, tensile stress is checked for top fiber and compressive stress for bottom fiber using Eq (1-12), the top and bottom fiber due to prestress and dead load moment is given as

$$\sigma_t = \frac{P_o}{A} - \frac{P_o e y_t}{I} + \frac{M_G y_t}{I} \quad (1-14)$$

$$\sigma_b = \frac{P_o}{A} + \frac{P_o e y_b}{I} - \frac{M_G y_b}{I} \quad (1-15)$$

The condition governing the design are given as [2]

$$\frac{P_o}{A} - \frac{P_o e y_t}{I} + \frac{M_G y_t}{I} \geq -\sigma_{tt} \quad (1-16)$$

$$\frac{P_o}{A} + \frac{P_o e y_b}{I} - \frac{M_G y_b}{I} \leq \sigma_{ct} \quad (1-17)$$

where P_o = the initial pre stress

M_G = dead load moment

I = Moment of inertia of the section

σ_{tt} = Allowable tensile stress at transfer

σ_{ct} = Allowable compressive stress at transfer

Under service load

At this stage the tensile stress for bottom fiber and compressive stress for top fiber should be checked.

The top and bottom fiber stresses are given as:-

$$\sigma_t = \frac{P}{A} - \frac{P e y_t}{I} + \frac{M_G y_t}{I} + \frac{M_L y_t}{I} \quad (1-18)$$

$$\text{and, } \frac{P}{A} - \frac{P e y_t}{I} + \frac{M_G y_t}{I} + \frac{M_L y_t}{I} \leq \sigma_{cw} \quad (1-19)$$

The condition governing the design are given as:-

$$\sigma_b = \frac{P}{A} + \frac{P e y_b}{I} - \frac{M_G y_b}{I} - \frac{M_L y_b}{I} \quad (1-20)$$

$$\frac{P}{A} + \frac{P e y_b}{I} - \frac{M_G y_b}{I} - \frac{M_L y_b}{I} \geq -\sigma_{tw} \quad (1-21)$$

where P = prestress after losses

M_L = live load moment at the section being considered

σ_{cw} = Allowable comp. Stress under working load

σ_{tw} = Allowable tensile stress under working load

In actual design of prestressed concrete section, similar to any other type of section, a certain amount of trial and error is inevitable. There is general lay out of structure that must be chosen as a start but

which may be modified as a process of a design develops. There is the dead weight moment which influence the design but which must be assumed before checking the stresses at critical points. There is the approximate shape of the concrete section governed by both practical and theoretical considerations that must be assumed for trial. Because of these variables, it has been found that the best procedure is one of trial and error approach guided by known relations that enable the final results to be obtained with out excessive work. This can be developed from pressure line approach [1].

In section 1.6.3, It was explained that pressure line method based on the assumption of treating the stress in concrete due to prestress as a center of pressure C in the concrete located at distance a from the center of prestress T in steel, to form internal couple to resist external moment [1]. This concept is also used in design of a reinforced concrete section.

There is, however, an essential difference between the behavior of a prestressed and of a reinforced concrete section. The different is explained as follows:

- 1 In a reinforced concrete section, as the external bending moment increases, the magnitude of the force C and T is assumed to increase in direct proportion while the lever arm jd between the two force remain practically constant.
- 2 In prestressed concrete section under working load as external bending moment increases, the magnitude of C and T remain practically constant while the lever arm a lengthen almost proportionally.

Since the location of T remain fixed, we get a variable location of C in a pre stressed section as bending moment changes. For a given moment M , C can be located as:-

$$C \times a = T \times a = M$$

$$a = M / C = M / T$$

Thus When $M = 0, a = 0$ and C coincide with T .

It is well to mention some of the simple relation between stress distribution and the location of C according to elastic theory. In Fig 1.5 if C coincides with the top or bottom kern point, stress distribution will be triangular with zero stress at bottom or top fiber, respectively. If C falls within the kern, the entire section will be under compression. If outside the kern some tension will exist.

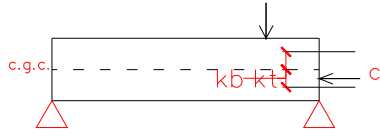

Fig. 1.5

Doing a preliminary design will simplify or shorten a trial and error procedure. A preliminary design can be made based on knowledge of internal C-T couple acting in section. In practice the depth h of the section is given, known or assumed as is the total moment M_T on the section. Under working load, the lever arm for the internal couple could vary between 30 to 80% of the height of the section and average about $0.65h$ [1]. Hence the required effective force can be computed from

$$F = T = \frac{M_T}{0.65h} \quad (1-22)$$

For that assumed lever arm, if the unit effective pre stress is f_{se} for the steel. Then the area of steel required is

$$A_{ps} = \frac{F}{f_{se}} = \frac{M_T}{0.65h \times f_{se}} \quad (1-23)$$

The total pre stress $A_{ps} \times f_{se}$ is also the force C on the section. This force will produce an average unit stress on the concrete of

$$\frac{C}{A_c} = \frac{T}{A_c} = \frac{A_{ps} \times f_{se}}{A_c}$$

For preliminary design, the average stress can be assumed to be about 50% of the maximum allowable stress f_c , under working load [1]. There fore,

$$\begin{aligned} \frac{A_{ps} \times f_{se}}{A_c} &= 0.5 f_c \\ A_c &= \frac{A_{ps} \times f_{se}}{0.5 f_c} \end{aligned} \quad (1-24)$$

Note that in the above procedure the only approximations made are the coefficients of 0.65 and 0.5. These coefficients vary widely, depending on the shape of the section; however with experience they can be closely approximated for each particular section, and the preliminary design can be made rather accurately.

A more accurate preliminary design can be made if the dead load moment M_G is known in addition to the total moment M_T . If M_G is much greater than 20+0 30% of M_T , the initial condition under M_G generally will not govern the design, and the preliminary design needs be made only for M_T . When M_G is small relative to M_T , then the c.g.s. can not be located too far out side the kern point, and the design is controlled by $M_L=M_T-M_G$. In this case the resisting lever arm for M_L is given approximately by K_t+K_b , which average about $0.5h$ [1]. Hence, the total effective pre stress required is:-

When M_G/M_T is small, this equation should be used instead of (1-23) but equation 1-24 is still applicable

$$F = \frac{M_l}{0.50h} \dots\dots\dots (1-25)$$

Using the preliminary design, a trial and error procedure may be developed to get the final design as follows:-

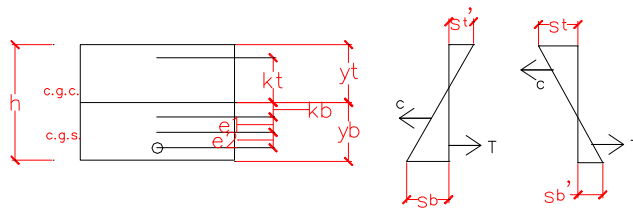

Fig. 1.6

In this procedure, some tensile stress in concrete is allowed

For small ratio of M_G/M_T .

If tensile stress σ_t is allowed in the top fibers, the center of compression C can be located below the bottom kern by the amount of

$$e_1 = \frac{\sigma'_t I}{F_o y_t} = \frac{\sigma'_t A K_b}{F_o} \quad (1-26)$$

For given moment M_G , the c.g.s can be located below C by the amount of

$$e_2 = \frac{M_G}{F_o} \quad (1-27)$$

The maximum total amount that c.g.s can be located below the kern is given by

$$e_1 + e_2 = \frac{M_G + \sigma'_t \times A \times k_b}{F_o} \quad (1-28)$$

The c.g.s having been located at some value e below c.g.e, the lever arm a under working load is known. For an allowable tension in the bottom, the moment carried by the concrete is

$$\sigma'_b \frac{I}{Y_b} = \sigma'_b \times A \times k_t \quad (1-29)$$

The net moment $MT - \sigma'_b A k_t$ is to be carried by the pre stress F with the lever arm action up to the top kern point, hence the total arm is

$$a = k_t + e \quad (1-30)$$

And the pre stress F required is:-

The bottom fiber stress at transfer can be calculated as follows

$$F = \frac{MT - \sigma'_b A k_t}{a} \dots\dots$$

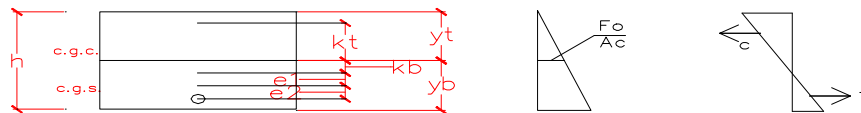

Fig. 1.7

$$\sigma_b = \frac{F_o}{Ac} \frac{h}{y_t} \quad \sigma'_t \frac{y_b}{y_t}$$

a) section property Fig. 1.7	b) Just after transfer due to dead load & prestress	c) allowing tension at top fiber
------------------------------------	---	-------------------------------------

So total stress at bottom fiber for the c.g.s located at $e = e_1 + e_2$ from bottom kern point is given by

$$\sigma_b = \frac{F_o h}{A_c Y_t} + \frac{\sigma_t^1 y_b}{y_t} \quad (1-32)$$

From which we have

$$A_c = \frac{F_o h}{\sigma_b Y_t - \sigma_t^1 y_b} \quad (1-33)$$

Similarly, the top fiber stress under working load is given by

$$\sigma_t = \frac{F h}{A_c y_b} + \sigma_b^1 \frac{y_t}{y_b} \quad (1-34)$$

From which

$$A_c = \frac{F h}{\sigma_t y_b - \sigma_b^1 y_t} \quad (1-35)$$

where F_o = initial pre stress

F = Effective pre stress

σ_b^1 = Allowable tensile stress at bottom fiber or (under working load)

σ_t^1 = Allowable tensile stress at top fiber at transfer

To summarize the procedure of the design we have:

Step 1. From the preliminary design locate c.g.s below bottom kern by using eq(1-28)

$$e_1 + e_2 = \frac{M_G + \sigma_t^1 \times A \times k_b}{F_o}$$

Step 2. From the above location of c.g.s compute the effective pre stress F (and the initial pre stress F) by equation (1-31)

$$F = \frac{M_T - \sigma_b^1 \times A \times k_t}{k_t + e}$$

and

$$F_o = \frac{F}{f_{se}}$$

Step 3. Compute the required Ac by using (1-33) and (1-35)

$$A_c = \frac{F_o h}{\sigma_b y_t - \sigma_t^1 y_b}$$

and

$$A_c = \frac{F h}{\sigma_t y_b - \sigma_b y_t}$$

Step 4. Revise the preliminary section to meet the above requirement for F and Ac, repeat step 1 through 4 if necessary.

1.8.2. Ultimate Design

This method of design ensures that the section have enough resisting moment under over load. The computational effort involved in this method of design is less than that of the elastic design method, since the ultimate flexural strength of section can be expressed by simple semi-empirical formulas.

PRELIMINARY DESIGN

For preliminary design, it can be assumed that the ultimate resisting moment of bonded prestressed section is given by the ultimate strength of steel acting with a lever arm. This arm length varies with the shape of section and generally ranges between $0.6h$ and $0.9h$ with a common value of $0.8h$ [1]. Hence the area of steel is approximated by [1]

$$A_s = \frac{M_T \times m}{0.8h \times f_{su}}$$

where m = load factor

Assuming that the concrete on the compressive side is stressed to $0.85 f'_c$ then the required ultimate concrete area under compression is

$$A'_c = \frac{M_T \times m}{0.8h \times 0.85 f'_c}$$

Which is supplied by compression flange (occasionally with the help of part of the web). The web area and the concrete area on the tensile side are designed to provide the shear resistance and encasement of steel, respectively. In addition, the concrete on the precompressed tensile side has to stand the prestress at transfer. For a preliminary design, these areas are often obtained by comparison with previous designs rather than by making any involved calculation.

The chief difficulty in ultimate design is the load factor which is dependent on the code being followed in the design. For the present it will be assumed that in the design. For the present it will be assumed that a load factor of 2 will be sufficient for steel and 2.5 for concrete.[1]

Final Design

Although the above illustrate a preliminary design based on ultimate strength, a final design is more complicated in that the following factors must be considered [1].

- i. Proper and accurate load factors must be chosen for steel and concrete, related to the design load and possible over load for particular structure.
- ii. Compressive stresses at transfer must be investigated .
- iii. The approximate location of the ultimate neutral axis may not be easily determined for certain section.
- iv. Design of the web will depend on shear and other factors.
- v. The effective lever arm for the internal resisting couple may have to be more accurately computed.

In spite of these factors, a reasonably good final design for flexure can be made for bonded section based on ultimate strength consideration. At present time, both the elastic and the ultimate designs are used for prestressed concrete. The majority of designs still follow the elastic theory however, which ever method is used for design, the other one must often be applied for checking. For example, when the elastic theory is used in design, it is common practice to check for the ultimate strength to carry

overloads. When the ultimate design is used, the elastic theory must be applied to determine whether the section is overstressed under certain conditions of loading and whether the deflections are excessive.

CHAPTER TWO

Application Of Prestressed Concrete On Bridge

A bridge can be constructed with reinforced concrete, pre stressed concrete, structural steel, timber etc. the application of any type of construction for a given bridge is depend on its economy, feasibility of its construction and functional requirements. Among these factors, economy of the bridge is the most important factor in order to decide the type of construction to be applied for the bridge.

At early age of pre stressed concrete, the problem of relative economy of this type of construction as compared to others was a controversial issue. Some engineers over estimate the additional labor involved. Others held an optimistic out look on its saving in material. With numerous pre stressed concrete structure built all over the world, its economy is no longer in doubt. Like any new promising type of construction, it will continue to grow as more engineers and builders masters its techniques. But, like any other type of construction, it has its own limitation of economy and feasibility so that it will suit certain conditions and not others.

The time is also past when one or two specific instances of the relative economy of prestressed concrete as against other types could be cited as positive proof either for or against its adoption. Basic quantities of data are now known for prestressed concrete, and the unit price for prestressing is stabilized.

From an economic point of view, conditions favoring pre stressed concrete applications on bridge structure can be listed as follows [1]

1. Long span bridges, where the ratio of dead load to live load is large, so that saving in weight of structure becomes significant item in economy. A minimum dead to live load ratio is necessary in order to permit the placement of steel near the tensile fiber, thus giving it the greatest possible lever arm for resisting moment for long span bridges, the relative cost of anchorage is also lowered

2. Reduced weight of structure as result of using pre stressed concrete will lower the cost of foundation (sub structures).
3. Heavy loads, where large quantities of materials are involved so that saving in materials becomes, worthwhile.
4. Multiple units, where forms can be reused and labor mechanized so that the additional cost of labor and forms can be minimized.

There are other conditions which, for certain local are not favorable to the economy of prestressed concrete application in bridges but which are bound to improve as time goes on.

These are [2]:-

1. The availability of builders experienced with the work of pre stressing
2. The availability of equipment's for post-tensioning and of plants for pre tensioning.
3. The availability of engineers experienced with the design of pre stressed concrete bridge
4. Improve codes on pre stressed concrete

These are the main reason for rare application of pre stressed concrete in bridge structures in our country.

From engineering and safety points of view, condition favoring pre stressed concrete application in bridge structure:-

- i. No crack section
- ii. Corrosion prevented
- iii. High shear resistance
- iv. Relatively small depth for long span compared to other types

Prestressed concrete is used for decks, beams and girders of long span bridge. And it is also used deck for cable stayed and suspension bridges.

CHAPTER THREE

Optimization Theory

Optimization is the act of obtaining the best result under given circumstance. In design, construction, and maintenance of any engineering system, engineers have to take many technological and managerial decision at several stages. The ultimate aim of all such decision is to either minimize the effort required or maximize the desire benefit. Since the effort required or the benefit desired in any practical situation can be expressed as a function of a certain design variables, optimization can be defined as the process of finding the conditions that give the minimum or maximum value of a function. Without loss of generality optimization can be taken to mean minimization of a function since the maximum of a function can be found by seeking the minimum of the negative of the same function.

The available method of optimization may conveniently be divided into two distinctly different categories as follows [5]:-

1. **Analytical method**:- Which usually employ the mathematical theory of calculus, variation method etc.
2. **Numerical method**:- which are usually employing a branch in the field of numerical mathematics called programming method. The recent developments in this branch are closely related to the rapid growth in computing capacity affected by the development of computers. In numerical methods, a near optimal design is automatically generated in iterative manner. An initial guess is used as starting points for a systematic search for better design. The search is terminated when certain criteria are satisfied; indicating that the current design is sufficiently close to the optimum.

3.1 Engineering Applications Of Optimization

Optimization, in its broader sense, can be applied to solve any engineering problem. To show the wide scope of the subject, some of typical application from different engineering discipline are given below

1. Design of a civil engineering structure like frames foundation, bridges, towers and dams for minimum cost.
2. Design of air craft and aerospace structures for minimum weight

3. Design of pumps, twines and heat transfer equipment for maximum efficiency
4. Optimal design of electrical machinery like motors generators and transformer
5. Optimal design of chemical processing equipment and plants etc.

3.2. Statement Of An Optimization Problem

An optimization or a mathematical programming problems can be stated as follows:-

$$\text{Find } X = \{x_1, x_2, \dots, x_n\} \quad \text{which minimize } F[\{X\}]$$

Subject to constraints

$$\begin{aligned} g_j(x) &\leq 0, j = 1, 2, \dots, m \\ \text{and} & \\ h_j(x) &= 0, \end{aligned} \tag{3-1}$$

where X is an n-dimensional vector called the design vector, $F(X)$ is called the objective function $g(x)$ and $h(X)$ are, respectively, the equality and inequality constraints. The constrained stated in Eq (3-1) is called a constrained optimization problem.

Some optimization problems do not involve any constraints and can be stated as:-

$$\text{Find } \mathbf{X} = \{x_1, x_2, \dots, x_n\} \quad \text{which minimize } F[\{X\}]$$

Such problems are called unconstrained optimization problems

Design vector:- any engineering system or component is described by a set of quantities some of which are viewed as variables during the design process. In general certain quantities are usually fixed at the outset and these are called pre assigned parameter. All the other quantities are treated as variables in the design process and are called design or decision variable. $X_i, i = 1, 2, \dots, n$. The design variables are collectively represent as a design vector.

In structural design, from physical point of view, the design variables $X = \{x_1, x_2, \dots, x_n\}$ that are varied by optimization procedure may represent the following properties of the structure:

1. The mechanical and physical properties of material
2. Topology of the structure i.e. the pattern of connection of members or the number of element in a structure.

3. The configuration or geometric lay out of the structure
4. The cross-sectional dimensions or the member sizes

From mathematical point of view, it is important to distinguish between continuous and discrete variables. In case of discrete variables with a large number of values uniformly distributed over a given interval, use of continuous variable representation is often satisfactory, followed by selection of the nearest a variable discrete value. When a strictly discrete design variable is handled in this way. It will be categorized as pseudo-discrete. However, it should be recognized that the situation arises when it will be essential to employ discrete or integer variables, the latter represent the number of elements in the structure, for example.

Design Constraints:- In many practical problems, the design variable cannot be chosen arbitrarily, rather they have to satisfy certain specified functional, behavioral and other requirements. The restrictions that must be satisfied in order to produce an acceptable design are collectively called constraints. If the design meets the entire requirement placed on it, it is called a feasible design.

From the physical point of view we may identify two kinds of constraint.

1. Constraints imposed on the design variables and which restrict their range. For reasons other than behavior considerations will be called design constraints or side constraints [4]. These constraints, which are explicit in form, may derive from various considerations such as functionality, fabrication, or aesthetics thus, a side constraint is a specified limitation (upper or lower bound) on a design variable, or a relationship which fixes the relative value of a group of design variables, examples of such constraints in structural design include minimum thickness plate, maximum height of a shell structure or minimum slope of a roof structure or minimum slope of a roof structure.
2. Constraints that derive from behavior requirements will be called behavior constraints in structural design, for example, limitation on maximum stresses, displacements, or buckling strength are behavior constraints. Explicit and implicit behavior constraints are often given by formulas presented in design codes or specifications. However implicit behavior constraints are generally implicit in any case the constraint must be a computable function of the design variable.

From a mathematical point of view, both design or side and behavior constraints may usually be expressed as a set of inequalities

$$g_i(X) \leq 0 \quad j = 1, \dots, m$$

where m is the number of inequality constraints and (X) is the vector of design variables often, in a structural design problem, one has also to consider equality constraints of the general form $h_j(x) = 0, j = 1, \dots, p$. Where p is the number of equalities. In many cases equality constraints can be used to eliminate variables from optimization process, thereby reducing their number.

Objective function:- the conventional design procedures aim at finding an acceptable or adequate design, which merely satisfies the functional and other requirements of the problem. In general there will be more than one acceptable design and the purpose of optimization is to choose the best out of the many acceptable design variables. Thus a criterion has to be chosen for comparing the different alternate acceptable designs and selecting the best one. The criteria with respect to which the design is optimized when expressed as a function of the design variable is called objective function. The choice of the objective function is governed by the nature of the problem. For instance, in aircraft and aerospace structure design problems, the objective function is usually the weight of the structure, in civil engineering structure designs, the objective is usually taken as the minimization of cost. $Z = f(x)$

3.3 Classification Of Optimization Problem

Generally optimization problems can be classified based on the nature of equation involved into two categories. This is based on the expression for the objective function and the constraints [4].

1. Linear optimization problems:- where the expression for objective function and the expression for all constraints are linear functions of design variables.
2. Non-linear optimization problem:- where the expression for objective function or the expression for some or all of the constraints are non-linear functions of the design variables.

CHAPTER FOUR

Optimization Methods

There is a single method available for solving all optimization problems efficiently. Hence a number of optimization methods have been developed for solving different types of optimization problem. Here in this section, we consider some of the techniques used in mathematical programming problems.

In chapter three, the mathematical programming problems were generally classified as linear programming problems and non-linear programming problems. In the following section, the methods usually used in optimizing these types of problems will be discussed in details.

4.1 Linear Programming Methods

Linear programming (LP) is a fundamental mathematical method. The special characteristic of the problem is that all the constraints and the objective function are expressed in linear terms of the variables. The constraint might be either equalities or inequalities and the objective function is minimized or maximized although only a relatively small part of engineering design problems can be formulated as LP, the method is widely used. Some of the reason for its popularity are[5]:-

1. The exact global optimum is reached in a finite number of steps. There are no local optima.
2. Computer programs of LP are most efficient. Systems with relatively large number of variable and constraints can be solved in a reasonable computation time.
3. Due to the high efficiency and reliability of LP programs they are often used as subroutines in solving non-linear programming problems.
4. Some practical non-linear problems are often approximated by a linear formulation and solved by LP algorithm.

In this section, formulation of LP problem is presented and simplex method for solution is briefly discussed.

4.1.1. Problem Formulation

The general LP problem can be stated as one of choosing the variable

$$Z = \sum_{j=1}^n c_j x_j \rightarrow \min \quad (4-1)$$

Subjected to

$$\sum_{j=1}^n a_{ij} x_j (\leq, =, \geq) b_i \quad i = 1, 2, \dots, m \quad (4-2)$$

And

$$x_j \geq 0 \quad j = 1, \dots, n \quad (4-3)$$

where a_{ij} , b_i and c_j are constant coefficients. The notation ($\leq, =, \geq$) means that the constraints might be either equalities or in equalities (\leq or \geq) This formulation is general and cover wide range of problems, as can be seen from the following observations:-

1. Although the objective function Z in Eq (4-1) is minimized problems of maximization are also included in the present formulation:- instead of maximizing z , the solution can be reached by minimizing $-Z$.
2. The constraints in Eq 4-2 might be either equalities or in equalities (\leq or \geq) From computational consideration the coefficient b_i are required to be non negative. This requirement can always satisfied since in cases of $b_i < 0$, we may multiply the corresponding constraint by (-1) so that b_i will become positive.
3. For purpose of computation Eq 4-3 requires that all variable be limited to non-negative range, if in the original problem variables may presses. Negative values we can expressed them as difference between two non negative variables

$$x_k = x_k' - x_k'' \quad (4-4)$$

Of variable is increased. Other transformations can be used ensure non negativity of the variables. If any specific variable x_k has a lower bound limitation

$$-x_k^L \leq x_k \quad \dots \quad (4-5)$$

where $(-x_k^L) < 0$

Then we may transform to a new variables x_k , given by

$$x_k = x'_k - x_k^L \dots \dots \dots (4-6)$$

The constraint of Eq 4-5 will becomes: -

$$0 \leq x'_k \dots \dots \dots (4 - 7)$$

The advantage in using this transformation is that the number of variables remains the same. in addition, we don't need to consider constraint (4-7) since it is included in Eq (4-3).

For the purpose of computation, a standard form of LP is utilized. It permits use of a standard algorithm and simplifies the discussion of its application. It will be shown that all linear programming problems can be written in the following standard form:

▮

$$\begin{aligned} \text{find } \{x\}^T = \{x_1, \dots, x_n\} \text{ That minimizes} \\ Z = \sum_{j=1}^n c_j x_j \dots \dots \dots i = 1, \dots, m \end{aligned}$$

subjected to

$$\sum_{j=1}^n a_{ij} x_j = b_i \quad (4-8)$$

And

$$x_j \geq 0 \quad j = 1, \dots, m \quad (4 - 10)$$

In order to convert inequality in Eq (4-2), we introduce new variables. If the h constraints is an equality of the form

$$\sum_{j=1}^n a_{hj} x_j \leq b_h \quad (4 - 11)$$

A non-negative slack variable, $x_{n+h} \geq 0$, is added to the left hand side, resulting in equality.

If the $k + h$ constraint is an equality of the form

$$\sum_{j=1}^n a_{hj} x_j + x_{n+h} = b_h \quad (4-12)$$

A non negative surplus variable x_{n+k} is subtracted so we have

$$\sum_{j=1}^n a_{kj} x_j - x_{n+k} = b_k \quad (4-14)$$

The slack and surplus variables satisfy the non-negativity constraint of Eq (4-3). Thus, any vector (x) that satisfy the equalities (4-12) and (4-14) will also satisfy the original in equalities (4-11) and (4-13). In addition, since all the coefficient of the new variables in objective function is zero, their contribution is zero and the original function $\dots F(X)$ is unchanged. Using the transformation of Eq (4-12) or (4-14) for all m equalities, the original problem can be formulated in standard form of Eqs (4-8), (4-9) and (4-10)

If $m = n$ in the standard form problem and none of the equation (4-9) are redundant, there is only one solution to the system of equations. If $m > n$ in this case the system possesses an infinity of solutions of which we seek the one that minimizes z and satisfies the non negativity constraints $x_j \geq 0$

A number of standard definitions can be made now a vector that satisfies the equalities (4-9) represent a solution. If the non-negative constraints (4-10) are also satisfied, this is a feasible solution. The optimal feasible solution, which minimizes the objective functions, a basic feasible solution is a feasible solution with no more than m non-zero x_j . In other words, it has at least $(n - m)$ x_j that are zero. A non-degenerate basic feasible solution has exactly m positive x_j .

4.1.2 Method of Solution

It can be stated that if the standard form LP problem has a bounded solution, the minimum of Z is attained at one of the basic feasible solutions of the program. This is an extreme powerful result since there are a finite number of basic solutions.

The simplex method is a powerful computational scheme for obtaining basic feasible solutions. If a solution is not optimal, the method provides a procedure for finding a neighboring basic feasible solution, which has an improved value of Z . The process is repeated until, in a finite number of steps an optimum is found.

Rewrite Eq (4-9) in their expanded form

$$\begin{aligned} a_{11}x_1 + a_{12}x_2 + \dots + a_{1n}x_n &= b_1 \\ \cdot & \\ \cdot & \\ a_{m1}x_1 + a_{m2}x_2 + \dots + a_{mn}x_n &= b_m \end{aligned} \tag{4-15}$$

It is possible to place this system in to a form which at least one solution can readily be deduced we obtain this form by pivoting (4-15) until there are m columns, each containing zeros and a single 1.0 these can always be arranged in the form

$$\begin{array}{l} X_1 \\ X_2 \\ \cdot \\ \cdot \\ X_m \end{array} \begin{array}{c} | \\ \hline | \\ | \\ | \\ | \end{array} \begin{aligned} + a'_{1,m+1}x_{m+1} \cdots a'_{1,n}x_n &= b'_1 \\ + a'_{2,m+1}x_{m+1} + \cdots a'_{2,n}x_n &= b'_2 \\ + a'_{m,m+1}x_{m+1} + \cdots a'_{m,n}x_n &= b'_m \end{aligned}$$

Where the primes indicate that a'_{ij} are changed from the original system. Such a system is said to be canonical or in a canonical form one solution to the system is always.

$$x_j = b'_j \quad j = 1, 2, \dots, m \tag{4-17}$$

$$x_j = 0 \quad j = (m+1), (m+2), \dots, n \tag{4-18}$$

This solution is a basic solution and the first m of the x_j are basic variables. If all the b_j are non negative, then the solution given by Eq (4-17 and (4-18) is basic feasible solution. The general procedure for solving LP problems consists in going from one basis, or canonical form, to an improved one until the optimum is found.

Criteria for Choosing an Improved Basic Feasible Solution

Given a system in conical form (4-16) corresponding to a basic feasible solution, we can pivot to a neighboring basic feasible solution by bringing some specific variable x_t in to the basis in place of some x_s the objective function Z can be expressed in terms of the non basic variable by elimination the basis ones.

$$Z = Z^o + \sum_{j=m+1}^n c'_j x_j \quad (4 - 19)$$

Where Z^o is a fixed value and C'_j are constant coefficients of Z in its new form. Note that Z^o represent the value of Z for the current basic solution, since $x_j = 0$ for $J = (m + 1), \dots, n$. The question now is how to choose x_t and x_s .

If any specific coefficient C'_t -(correspond to a non basic variable x_t) in the objective function of the canonical form-Eq(4-19)--is negative, then the value of Z can be reduced by increasing the variable x_t from zero, while keeping all the other non basic variables at zero. Hence, to improve the solution, we can bring any such x_t in to the basis. If more than one C'_t is negative, we can choose the one, which gives $C'_t = \min(C'_j)$ (4-20)

This choice selects the variable for which the objective function reduces at the greatest rate. If $\min(C'_j)$ is not negative, then there is no variable that can be increased to improve the objective function, and the optimality condition is satisfied.

Bringing the chosen x_t in to the basis, we have to determine now that variable x_s will leave the basis. Going from one basic solution to another, we increase x_t from zero to some positive value during the process, while x_s becomes zero. If we are to keep the solution feasible, we cannot increase x_t from zero by more than it takes to make the "first" x_s just go to zero, since to increase it further would make x_s negative. Suppose we take a canonical form (4-16):- then keeping all the non basic variables zero except x_t , we can see the effect of increasing x_t on the basic variable from.

$$x_i = b'_i - a'_{it} x_t \quad i = 1, \dots, m \quad t > m \quad (4 - 21)$$

If any specific a'_{st} is positive, the largest value of x_t before x_s becomes negative is

$$x_t = \frac{b'_s}{a'_{st}} \quad (4-22)$$

If a'_{st} is negative, no positive x_t will make x_s negative. Therefore, x_t is bounded

$$x_t = \min(b'_i / a'_{it}) \quad \text{for } a'_{it} > 0 \quad (4-23)$$

In other words, since we wish to make x_t basic (non zero) in place of some other variable x_s which will become non basic (zero), we must choose the row s for which $x_s = 0$ by Eq (4-22), and all others are non negative. Hence row s must produce the minimum value in Eq (4-23). Note also that the chosen variable x_s has a coefficient of 1.0 in the s^{th} row.

In summary, once it has been determined to bring the currently non basic variable x_t into the basis (using the criteria of Eq(4-20)), we compute s by the condition of Eq (4-23)

$$\frac{b'_s}{a'_{st}} = \text{Min } (b'_i / a'_{it}) \quad \text{for } a'_{it} > 0 \quad (4-24)$$

If no such s exists, i.e. there is no $a'_{it} > 0$, x_t can be increased indefinitely without the solution becoming infeasible and we have an unbounded solution. Otherwise we pivot to a new basic feasible solution that includes x_t in place of x_s .

Going From One Basic Feasible Solution To Another One

Once t and s have been determined, transformation to the new basis is performed by the following pivot operation, where a'_{st} is the pivot term

$$y_{sj}^* = \frac{y_{sj}}{a'_{st}} \quad (4-25)$$

$$y_{ij}^* = y'_{ij} - \frac{y'_{it}}{a'_{st}} y'_{sj} \quad i \neq s$$

y_{ij}^* And y'_{ij} are the coefficients of the new and current basis, respectively in the i th row and the j th column. The transformation is carried out also for the column b'_i and for the row of the objective function Z .

Special Cases

If we pivot on a row for which b'_i is zero, the value of the objective function or of the basic variables will not change. In such a case the value of the basic variable corresponding to the zero b'_i and we have a degenerate basic feasible solution. In optimization procedure, we will still perform such pivots, since doing so may allow us to proceed to other non-degenerate solutions.

If all the coefficient a'_{it} in any column t corresponding to a negative C'_i are negative, x_t can be increased indefinitely without causing any variable to become zero the result is that the objective function can be reduced indefinitely and we have unbounded solution.

Initial Basic Feasible Solution

A basic feasible solution is required as a starting point. The object is to form an initial canonical system in which the coefficients a_{ij} of the basic feasible solution can be found. If all constraints in the original problem are in equalities (\geq) with non-negative b_i , then in order to get the standard form we have to add slack variables to all the constraints.

The coefficient of slack variables form in this case a unit matrix, thus they can be chosen as initial basic variables of the canonical system, this is not the case if some of the constraints are equalities or inequalities. In order to start the solution with a unit matrix, we may add to each of the constraints a new variable called artificial variable the original system of equations (4-15) in its standard form will become

$$\begin{aligned} a_{11}x_1 + \dots + a_{1n}x_n + x_{n+1} + \dots &= b_1 \\ a_{21}x_1 + \dots + a_{2n}x_n + \dots + x_{n+2} &= b_2 \\ \cdot & \\ a_{m1}x_1 + \dots + a_{mn}x_n + \dots x_{n+m} &= b_m \end{aligned} \quad (4-27)$$

Eq. (4-27) are expressed in canonical form where $x_j, j = (n + 1), \dots, (n + m)$ are artificial variables. A basic feasible solution of this system is ($b_i \geq 0$)

$$\begin{aligned} x_j &= 0 \\ x_{n+j} &= b_j \end{aligned} \quad \begin{array}{l} j = 1, 2, \dots, n \\ j = 1, 2, \dots, m \end{array} \quad (4-28)$$

The coefficients of the artificial variables in the original objective function are set equal to zero.

The algorithm for solving the problem with artificial variables consists of two phases. Phase I to find a basic feasible solution. If one exists, in which all artificial variables equal zero, and phase II to compute the optimal solution, in phase I we define an ‘artificial’ objective function.

$$Z = \sum_{j=n+1}^{n+m} x_j \quad (4-29)$$

Which is to be minimize if the minimum of Z' is zero, then all artificial variables have been eliminated from the basis and a new basic feasible solution is a variable, which contains only the variable of the original system $x_j, j = 1, \dots, n$. Then the artificial variables and objective function (Z') can be dropped and we proceed and solve phase II. If the minimum of Z' is greater than zero, then no basic feasible solution to the original problem exists.

General Iterative Procedure

1. Formulate the LP problem in a standard form namely:-
 - Non negative variables (use the transformation (4-4) or (4-6), if necessary)
 - Non negative b_i (multiply the constraint by -1 , if necessary)
 - All constraints are made in to equalities (add slack or surplus variable, if necessary)
 - The objective function is minimized (change sign, if necessary)
2. Form a starting canonical system with a basic feasible solution. Add artificial variables to the constraints.
3. Solve phase I, with the objective function (Z') equal to the sum of artificial variables, by steps 5 through 8.

4. If $\text{Min } Z' > 0$, the problem has no feasible solution terminate procedure. If $\text{min } Z' = 0$, eliminate all artificial variables and proceed with variables and objective function of the standard form problem.
5. Find the variable x_t to bring in to the basis by computing.

$$c'_t = \min_j (c'_j)$$

6. If $C'_t \geq 0$, the optimum has been found, terminate procedure. If $C'_t < 0$, find the variable x_s to be eliminated from the basis by computing

$$\frac{b'_s}{a'_{st}} = \min (b'_i / a'_{it}) \text{ for } a'_{it} > 0$$

$$y^*_{sj} = \frac{y'_{sj}}{a'_{st}}$$

$$y^*_{ij} = y'_{ij} - \frac{y'_{it}}{a'_{st}} y'_{sj} \quad i \neq s$$

7. If no such S exists, the solution is unbounded. Terminate procedure. If S has been found, a new basis and the objective function are computed by pivoting on S is the row in which x_s has a coefficient of 1.0 and y'_{ij} and y^*_{ij} are the coefficients of the new and the current canonical systems, respectively
8. Proceed with step 5,6 and 7 until termination

4.2 Non Linear Program

A general non linear programming (NLP) problem can be stated as one of choosing

$$\{x\}^T = \{x_1, x_2, \dots, x_n\} \text{ such that}$$

$$Z = F(x) \rightarrow \min \tag{4-30}$$

$$g_j(x) \leq 0 \quad j = 1, \dots, m \tag{4-31}$$

$$h_j(x) = 0 \quad j = 1, \dots, P \tag{4-32}$$

Z is the objective function expressed in non linear terms of the variables, Eq (4-31) are in equality constraints and Eq (4-32) are equalities, both non linear function of $\{x\}$ the equality (4-32) can often be eliminated and we may research the optimum in the feasible space defined by the inequalities (4-31). At present there is no efficient general purpose NLP method and a large number of algorithms have been proposed. In this section, some of those methods which are commonly used in optimal design are highlighted and one method (feasible direction method) is discussed. Limitations, we first familiar with their capacities and limitations, we first briefly discuss some concepts related to the optimization problem.

One difficulty is that there can be multiple relative minimum points. A point is said to be a relative (local) minimum if it has the least function value in its neighborhood, but not necessarily the least function value of all $\{x\}$ due to the nature of either the constraints or the objective function[5].

Relative minima may occur in NLP problems.

The nature of the objective function and the feasible region can be determined using the definitions of convex functions and convex set. A function is said to be convex if, on the line connecting every pair of points $\{x_1\}$ and $\{x_2\}$ in its domain of definition, the value of the function is less than or equal to a linear interpolation of

$$F(\{x_1\}) \text{ and } F(\{x_2\}), \text{ i.e.}$$

$$F(\alpha\{x_2\} + (1 - \alpha)\{x_1\}) \leq \alpha F(\{x_2\}) + (1 - \alpha)f(\{x_1\}) \quad 0 < \alpha < 1 \quad (4-33)$$

The function is strictly convex if the strict inequality holds. A negative of convex function is a concave function. Linear function is both convex and concave function, but neither strictly concave.

A set of points is called convex if the line segment joining any two points $\{x_1\}$ and $\{x_2\}$ is contained entirely within the set. Mathematically the set is convex if all $\{x_1\}$ and $\{x_2\}$ in the set, and $0 < \alpha < 1$, the point $\{y\} \equiv \alpha\{x_1\} + (1 - \alpha)\{x_2\}$ is also in the set. The set may be bounded or unbounded.

A convex programming problem for minimization is one with a convex objective function $F(\{x\})$ and convex inequality constraint function $g_j(\{x\})$. In this case, the feasible domain formed by a single inequality constraint can be shown to be convex. Furthermore, the intersection of convex domains is convex. Thus, if the individual domains $g_j(\{x\}) \leq 0$ are convex, the domain that is defined by all of them is also convex. A problem with equality constraint if the $h_j(\{x\})$ are linear and if $F(\{x\})$ and $g_j(\{x\})$ are convex. The intersection of linear equality constraints is convex, since a single linear equality constraint is a convex domain. Since all linear functions are convex a linear programming problem is always a convex problem.

The significance of the above definition is that in a convex programming problem any local minimum is a global one. However, it is often difficult to ascertain whether the functions in a given problem are convex. Problems which are not convex may still have only a global minimum or they may be solved for their relative minima, which provide useful information.

NLP problems can be divided into unconstrained and constrained problems. In unconstrained optimization we do not consider equation (4-31) and (4-32), and the problem is much easier to solve. Occasionally it is possible to eliminate some or all of the constraints from a problem. For example, K of the variable which appears in the equalities may be expressed in terms of the other variables then the constraint $h_j(\{x\}) = 0$ can be eliminated

Lagrange multipliers

Consider the problem of finding the optimum $\{x^*\}$ such that Eq(4-30) and (4-31) holds. It can be shown that at the optimum we must satisfy[5]

$$\{\nabla F\} + \sum_{j=1}^p \lambda_j \{\nabla h_j\} = \{0\} \quad (4-34)$$

$$h_j(\{x^*\}) = 0 \quad j = 1, \dots, P \quad (4-35)$$

Where λ_j are called lagrange multipliers, and $\{\nabla F\}$ and $\{\nabla h_j\}$ are gradient vectors, given by:-

$$\{\nabla F\} = \begin{Bmatrix} \partial F / \partial x_1 \\ \vdots \\ \partial F / \partial x_n \end{Bmatrix}$$

$$\{\nabla h_j\} = \begin{Bmatrix} \partial h_j / \partial x_1 \\ \vdots \\ \partial h_j / \partial x_n \end{Bmatrix} \quad \dots \quad (4-36)$$

The lagrange function is defined by:-

$$\phi(\{x\}, \{\lambda\}) = F + \sum_{j=1}^p \lambda_j h_j \quad (4-37)$$

In order to find a stationary point of ϕ over all $\{x\}$ and $\{\lambda\}$, we have to satisfy

$$\frac{\partial \phi}{\partial x_i} = 0 \quad i = 1, \dots, n \quad (4-38)$$

$$\frac{\partial \phi}{\partial \lambda_j} = 0 \quad j = 1, \dots, P \quad (4-39)$$

Based on the definition of Eq (4-37), the conditions of Eqs (4-38) and (4-39) can be shown to be identical to those of Eqs (4-34) and (4-35). It should be noted that not all solution of Eqs (4-34) and (4-35) will be constrained minima, since these conditions holds for constained maxima and saddle point. Further test are necessary to ensure that a point is a minimum. The geometric representaiton of Eq (4-34) is that at the minimum $\{\nabla F\}$ must be expressible as a linear combination of the normals to the surface $h_j(\{x\}) = 0$

We can apply the concept of lagrange multiplies to the in equality constaints of Eqs (4-31) by adding slack variable, s_j

$$h_j(\{x\}, s_j) = g_j(\{x\}) + s_j^2 = 0 \quad \dots \dots \dots \quad (4-40)$$

If $s_j = 0$ then $g_j(\{x\})=0$ if $s_j \neq 0$, then $g_j(\{x\}) < 0$. Eq. (4-40) can not be satisfied if $g_j(\{x\}) > 0$.

Applying the lagrange multiplier method to inequalities, we define

$$\phi(\{x\}, \{s\}, \{\lambda\}) = F + \sum_{j=1}^m \lambda_j (g_j + s_j^2)$$

The stationery condition for ϕ are:-

$$\frac{\partial \phi}{\partial x_i} \equiv \frac{\partial F}{\partial x_i} + \sum_{j=1}^m \lambda_j \frac{\partial g_j}{\partial x_i} = 0 \quad \dots \dots \dots \quad i = 1, \dots, n \quad (4-42)$$

$$\frac{\partial \phi}{\partial s_j} \equiv \partial \lambda_j s_j = 0 \quad \dots \dots \dots \quad j = 1, \dots, m \quad (4-43)$$

$$\frac{\partial \phi}{\partial \lambda_j} \equiv (g_j + s_j^2) = 0 \quad \dots \dots \dots \quad j = 1, \dots, m \quad (4-44)$$

Eqs (4-44) ensure that the inequalities $g_j \leq 0$ are satisfied. Eqs(4-43) states that either λ_j or s_j is zero, which implies that either the constraint is active ($g_j = 0$) and must be considered in testing Eq (4-42), or it is inactive ($\lambda_j = 0$). Eqs (4-42) requires that $\{\nabla F\}$ lies in sub space spanned by those $\{\nabla g_j\}$ which correspond to the active constraints.

Kuhn-Tucker conditions

This is used as a test criteria for optimality for a given point rather than solving the set of Eqs (4-42),(4-43) and (4-44). Define a set of integers $j = 1, \dots, J (J \leq m)$ as a subscript of the constraint g_j that are active at the point being tested. A point $\{x\}$ may be a minimum if all the constraints $g_j \leq 0$ are satisfied [Eqs(4-44)] and if there exist λ_j such that

$$\{\nabla F\} + \sum_{j=1}^J \lambda_j \{\nabla g_j\} = \{0\} \quad (4-45)$$

Equation (4-45) are based on the conditions of Eqs (4-42), considering only the active constraints. With this definition, the conditions of Eqs (4-43) can now be excluded.

To avoid situations in which Eqs(4-45) are satisfied and yet $\{x\}$ is not a local minimum, we require

$$\lambda_j \geq 0 \quad j = 1, \dots, J$$

Eqs(4-45) and (4-46) are the kuhn-Tucker (KT) conditions for a relative minimum. Define a cone as a set of points such that if $\{\nabla g\}$ is in the set, $\lambda\{\nabla g\}$ is also in the set for $\lambda \geq 0$ the set of all non negative linear combination: -

$$\sum_{j=1}^J \lambda_j \{\nabla g_j\} \dots \lambda_j \geq 0$$

forms a convex cone. The KT conditions requires that $-\{\nabla F\}$ be with in the convex cone comprised by the active constraint normals $\{\nabla g_j\}$ ($j = 1, \dots, J$). These are the necessary conditions for a point to be a relative minimum, but they are not sufficient to ensure relative minimum. In convex programming problems. The Kuhn Tucker conditions are necessary and sufficient for a global minimum.

4.2.1 Methods For Unconstrained Minimization

This is an optimization problem with out constrained. The significance of this class of problem stems from the following reason[5].

1. Some design problems are eiter unconstrained or can be treated as un constrained during certain stages of the solution.
2. Some of the most power ful and convenient methods of solving constrained problems are based on transformation of the problem to one of unconstrained minimization
3. A number of methods suitable for unconstrained optimization can be extended and applied to constrained problems.

A point $\{x^*\}$ is a relative minimum of the function $F(\{x\})$ if there is region containing in its interior such that

$$F(\{x^*\}) \leq F(\{x\}) \tag{4-47}$$

For all $\{x\}$ in that region. The classical methods calculus give the following necessary conditions for the minimum of a function of n variable (x_1, x_2, \dots, x_n) with continous derivatives

$$\{\nabla F\} \equiv \left\{ \begin{array}{c} \frac{\partial F}{\partial x_1} \\ \vdots \\ \frac{\partial F}{\partial x_n} \end{array} \right\} = \{0\} \quad (4-48)$$

A point satisfying (4-48) is called stationary point of $F(\{x\})$ it is guaranteed to be a relative minimum, if the hessian matrix $\{J\}$ of the second derivatives

$$\{J\} \equiv \begin{bmatrix} \frac{\partial^2 F}{\partial x_1^2} & \dots & \frac{\partial^2 F}{\partial x_1 \partial x_n} \\ \vdots & & \vdots \\ \frac{\partial^2 F}{\partial x_n \partial x_1} & \dots & \frac{\partial^2 F}{\partial x_n^2} \end{bmatrix} \quad (4-49)$$

is positive definite. This means that the quadratic form $Q = \{A\}^T [J\{A\}]$ is positive for all choices of an arbitrary constant vector $\{A\}$, except that $Q=0$ when $\{A\} = \{0\}$.

Since no single method can be efficiently applied to all problems, many algorithms have been developed to handle different type optimizations. Some essential features should be considered before selecting a suitable solutions method[5].

- 1) Differentiability and continuity of $F(\{x\})$
- 2) Required accuracy of $\{x^*\}$ And accuracy of the objective function definition.
- 3) Special structure of $F(\{x\})$

Methods for minimizing a function along a line:- applicable for solving optimization problems in one variable. This operation of minimizing along specified directions in multivariable problems is basic to many NLP algorithms and often performed using polynomial fitting techniques.

Consider the case in which a point $\{x_q + 1\}$ is to be found by

$$\{x_q + 1\} = \{x_q\} + \alpha\{s_q\} \quad (4-50)$$

Where $\{x_q\}$ and direction $\{s_q\}$ are given, and the scalar α is a variable chosen as to minimize $F(\{x_q\} + \alpha\{s_q\})$ with respect to α . In general the problem is not solved in a finite number of operations, and we often attempt to find only an estimate of the minimum, such as that obtained by fitting a quadratic function or cubic function to known information. Note that F becomes a function of one variable α , and α^* which minimize $F(\alpha)$ doesn't produce the global minimum of F , unless the line $\{x\} = \{x_q\} + \alpha\{s_q\}$ contains a global minimum.

Directed search methods:- where the solution of the minimization problem is found by solving a sequence of minimization along a direction vectors, but without a need of using the deviative $\{\nabla F\}$. Direct search methods depend upon a direct comparison of the value of the objective function at several points, therefore the amount of effort required by the user is relatively low. Direct search method is based on the quadratic approximation of $F(\{x\})$ near the optimum point. Thus, this method is converge quadratically. This method employ the concept of conjugate direction

A set of n (non zero) direction vector $\{s_1\}, \{s_2\}, \dots, \{s_n\}$ are said to be conjugate to each other with respect to a given $(n \times n)$ positive definite symmetric matrix $[A]$, if

$$\{s_i\}^T [A] \{s_j\} = 0 \quad \text{For all } i \neq j \quad (4-51)$$

A set of such directions possesses an extremely powerful property, namely, if a quadratic functions Q is minimize sequentially, once along each of a set of linearly independent conjugate directions

form the basic for different methods all of which are quadratically convergent. Powell's method is one of the most successful method to develop conjugate direction[5].

Gradient methods: - while in direct search methods only the values of the objective functions are used to determine the direction of minimizations in the individual steps gradient methods use information available by computing the gradient vector of F

$$\{G\} = \{\nabla F\} = \begin{Bmatrix} \partial F / \partial x_1 \\ \vdots \\ \partial F / \partial x_n \end{Bmatrix} \quad (4-52)$$

The direction of $\{G\}$ coincides with that of greatest rate of change of F, and has that rate of change as its magnitude. The gradient is a vector that points in the direction of the steepest ascent, and therefore $\{-G\}$ is the direction of steepest descent.

Given a point $\{x_q\}$, the best direction to move to reduce the function value would seem to be the one in which the function decreases most rapidly, namely.

$$\{x_{q+1}\} = \{x_q\} + \alpha * \{-G_q\}$$

Where $\{G_q\}$ is the gradient vector at point $\{x_q\}$. The method defined by Eq. (4-53), called the method steepest descent. The solution is obtained by computing successively $\{G_q\}$ [(by Eq (4 52)], α^* (by minimization along line), and $\{x_{q+1}\}$ [(by Eq (4 52))] until the minimum is found.

CHAPTER FIVE

Formulation

In this section, an optimal design problem for a simply supported post-tensioned box-grader bridge will be formulated the shape of the girder selected is rectangle as shown in Fig. 5.1.

The constrain expression are developed base on AASHTO code and as much as possible the constraint that the code imposed on pre stressed concrete section are tried to be included.

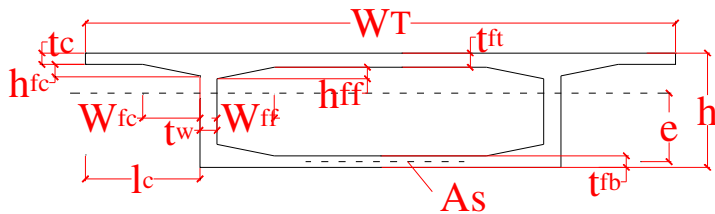

Fig. 5.1

5.1. Design Variable

The design variable in optimal design problem of prestressed concrete elements may include concrete dimensions, prestressing force (or pre stressing steel area, which is directly proportional to the pre stressing force), and the tendon eccentricity. But, in many cases, some of the concrete dimensions are assumed as pre assigned parameter, there by reducing the no of variable and simplifying the optimal design problem.

For this optimal design problem, the following dimensions or quantities are taken as design variable for design variable taken see fig 5.1

$$X1 = t_c$$

$$X2 = t_f$$

$$X3 = t_{fb}$$

$$X4 = t_w$$

$$X5 = l_c$$

$$X6 = e$$

$$X7 = A_s$$

W_{ff} , h_{ff} , w_{fc} , h_{fc} , w_T and H are taken as pre-assigned parameters.

5.2. Constraints

In general, the following constraint type are considered in pre stressed concrete design

- i) Normal stress constraint
- ii) Ultimate strength
- iii) Deflection
- iv) Design constraint

In this optimal design problem, in addition to the above constraint type, the maximum steel minimum steel and transverse bending strength will be considered.

5.2.1. Normal Stress Constraint

This limits the stress in concrete and is given by

$$\sigma^L \leq \sigma \leq \sigma^U$$

Where σ^L - lower bound (allowable tensile stress)

σ^u - Allowable compressive stress

σ - Stress in concrete. Note that, the tensile stresses are as-ve.

This constraint should be written for all load combination and all critical sections. Stresses are usually checked at transfer and after losses under all load condition. Considering the girder selected for this optimal design problem, these constraints are written at critical section as follow:-

Let σ_{tt} - allowable tensile stress at transfer

σ_{ct} - allowable compressive stress at transfer

σ_{cw} - allowable compressive stress at load combination (DL + super imposed load +LL)

σ_{tw} - allowable tensile stress at load combination (DL+ super imposed load +LL)

σ_{tt} and σ_{tw} are assumed to be positive

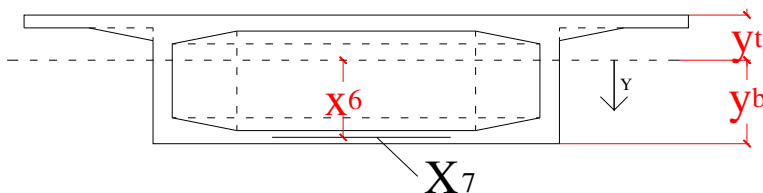

Fig. 5.2

- Let P_o - pre stressing force immediately after transfer
 P - effective pre stress force
 A_c - Area of the section
 I_c - moment of Inertia of the section
 M_G - Dead Load Moment at the critical section
 M_{LL} - (Live Load + Impact)
 M_s - Superimposed Load Moment at criteria section

At transfer

The stress at any point on the section is given by

$$\sigma(y) = \frac{P_o}{A_c} + \frac{P_o \times x_6 \times y}{I_c} - \frac{M_G \times y}{I_c} \quad (5-1)$$

Assume

$$r^2 = I_c / A_c \quad (5-2)$$

$$\sigma(y) = \frac{P_o}{A_c} \left[1 + \frac{x_6 \times y}{r^2} - \frac{M_G \times y}{P_o \times r^2} \right]$$

So stress at top fiber is

$$\sigma(-y_t) = \sigma_t = \frac{P_o}{A_c} \left[1 + \frac{x_6 \times y_t}{r^2} + \frac{M_G \times y_t}{P_o \times r^2} \right] \quad (5-3)$$

And stress at bottom fiber is

$$\sigma(y_b) = \sigma_b = \frac{P_o}{A_c} \left[1 + \frac{x_6 \times y_b}{r^2} - \frac{M_G \times y_b}{P_o \times r^2} \right] \quad (5-4)$$

Let

$$\frac{r^2}{y_t} = K_b \quad (5-5)$$

$$\frac{r^2}{y_b} = K_T.$$

Substituting Eq 5.5 in to Eq 5.3 and Eq. 5.4

$$\sigma_t = \frac{P_o}{A_c} \left[1 - \frac{x_6}{k_b} + \frac{M_G}{P_o \times k_b} \right]$$

and

$$\sigma_b = \frac{P_o}{A_c} \left[1 + \frac{x_6}{k_T} - \frac{M_G}{P_o k_T} \right]$$

This is equivalent to

$$\sigma_t = \frac{P_o}{A_c \times k_b} \left[k_b - x_6 + \frac{M_G}{P_o} \right]$$

$$\sigma_b = \frac{P_o}{A_c \times k_T} \left[k_T - x_6 + \frac{M_G}{P_o} \right]$$

Imposing the constraints:-

$$\sigma_t = \frac{P_o}{A_c \times k_b} \left[k_b - x_6 + \frac{M_G}{P_o} \right] \geq -\sigma_u$$

$$\sigma_b = \frac{P_o}{A_c k_b} \left[k_T + x_6 - \frac{M_G}{P_o} \right] \leq \sigma_{ct}$$

Rearranging gives

$$\frac{P_o}{A_c \times k_b} \left[k_b + x_6 - \frac{M_G}{P_o} \right] + \sigma_u \geq 0$$

$$\frac{P_o}{A_c \times k_T} \left[k_T + x_6 - \frac{M_G}{P_o} \right] - \sigma_{ct} \leq 0$$

Multiplying the first inequality by -1 and rearranging gives

$$\frac{P_o}{A_c \times k_b} \left[-k_b + x_6 - \frac{M_G}{P_o} - \frac{\sigma_u \times A_c \times k_b}{P_o} \right] \leq 0$$

$$\frac{P_o}{A_c \times k_T} \left[-k_T + x_6 - \frac{M_G}{P_o} - \frac{\sigma_{ct} \times A_c \times k_T}{P_o} \right] \leq 0$$

Since $\frac{P_o}{A_c \times k_b}$ and $\frac{P_o}{A_c \times k_T}$ are always positive, the above inequality will hold only if:-

$$-k_b + X_6 - \frac{M_G}{P_o} - \frac{\sigma_u \times A_c \times k_b}{P_o} \leq 0$$

$$k_T + X_6 - \frac{M_G}{P_o} - \frac{\sigma_{ct} \times A_c \times k_T}{P_o} \leq 0$$

$$P_o = f_i \times A_s = f_i \times X_7$$

where f_i -stress in tendon at transfer so the above in equality becomes:

$$G_1(x) = -K_b + X_6 - \frac{M_G}{f_i \times x_7} - \frac{\sigma_{tt} \times A_c \times K_b}{f_i \times x_7} \leq 0$$

$$G_2(x) = -K_T + X_6 - \frac{M_G}{f_i x_7} - \frac{\sigma_{ct} A_c K_T}{f_i x_7} \leq 0$$

At service load:-

For load combination (DL+LL+SI),the stress at any point on section is given by:-

$$\sigma(y) = \frac{P}{A_c} + \frac{P \times x_6 \times y}{I_c} - \frac{(M_G + M_s + M_{LL}) \times y}{I_c} \quad (5-5)$$

Let $M_T = M_G + M_s + M_{LL}$

So

$$\sigma(y) = \frac{p}{A_c} + \frac{p \times x_6 \times y}{I_c} - \frac{M_T \times y}{I_c}$$

Using (5.2)

$$\sigma(y) = \left[1 + \frac{x_6 \times y}{r^2} - \frac{M_T \times y}{p \times r^2} \right]$$

So stress at top fiber (σ_t) and bottom fiber (σ_b) will be

$$\sigma_t = \frac{p}{A_c} \left[1 - \frac{x_6 \times y_t}{r^2} + \frac{M_T \times y_t}{p \times r^2} \right] \quad (5-6)$$

$$\sigma_b = \frac{p}{A_c} \left[1 - \frac{x_6 \times y_b}{r^2} + \frac{M_T \times y_b}{p \times r^2} \right] \quad (5-7)$$

Substitution Eq 5.5 in the above equation gives

$$\sigma_t = \frac{p}{A_c \times k_b} \left[k_b - x_6 + \frac{M_T}{p} \right]$$

$$\sigma_b = \frac{p}{A_c \times k_T} \left[k_T + x_6 - \frac{M_T}{p} \right]$$

Imposing the constraint:-

$$\sigma_t \leq \sigma_{cw} \Rightarrow \frac{p}{A_c \times k_b} \left[k_b - x_6 + \frac{M_T}{p} \right] \leq \sigma_{cw}$$

$$\sigma_b \geq -\sigma_{tw} \Rightarrow \frac{p}{A_c \times k_T} \left[k_T + x_6 - \frac{M_T}{p} \right] \geq -\sigma_{tw}$$

Putting $p = f_{se} \times x_7$ (f_{se} is effective stress) and rearranging gives

$$\frac{f_{se} \times x_7}{A_c \times k_b} \left[k_b - x_6 + \frac{M_T}{f_{se} \times x_7} - \frac{\sigma_{cw}}{f_{se} \times x_7} \right] \leq 0$$

$$\frac{f_{se} \times x_7}{A_c \times k_T} \left[-k_T - x_6 + \frac{M_T}{f_{se} \times x_7} - \frac{\sigma_{tw} \times A_c \div K_T}{f_{se} \times x_7} \right] \leq 0$$

Since $\frac{f_{se} \times x_7}{A_c \times k_b} \geq 0$, the above inequality holds if only

$$G_3(x) = k_b - x_6 + \frac{M_T}{f_{se} \times x_7} - \frac{\sigma_{cw}}{f_{se} \times x_7} \leq 0$$

$$G_4(x) = -k_T - x_6 + \frac{M_T}{f_{se} \times x_7} - \frac{\sigma_{tw} \times A_c \times K_T}{f_{se} \times x_7} \leq 0$$

AASHITO also limit the compression stress in concrete for effective prestress and permanent load combination.

For this load combination the stress at bottom fiber

$$\sigma_b = \frac{p}{A_c} \left[1 + \frac{x_6 \times y_b}{T^2} - \frac{M_G \times y_b}{p \times r^2} \right] \quad (5-8)$$

$$\Rightarrow \sigma_b = \frac{p}{A_c} \left[1 + \frac{x_6}{k_T} - \frac{M_G}{k_T} \right]$$

$$\Rightarrow \sigma_b = \frac{p}{A_c \times k_T} \left[k_T + x_6 - \frac{M_G}{p} \right]$$

$$\sigma_b \leq \sigma_{cw} \Rightarrow \frac{p}{A_c \times k_T} \left[k_T + x_6 - \frac{M_G}{p} \right] \leq \sigma_{cw}$$

$$\Rightarrow \frac{f_{se} \times x_7}{A_c \times k_T} \left[k_T - x_6 + \frac{M_G}{f_{se} \times x_7} - \frac{\sigma_{tw} \times A_c \times K_T}{f_{se} \times x_7} \right] \leq 0$$

$$G_5(x) = k_T + x_6 - \frac{M_G}{f_{se} \times x_7} - \frac{\sigma_{cw} \times A_c \times K_T}{f_{se} \times x_7} \leq 0$$

AASHTO code gives the following value for allowable stresses ($\sigma_t, \sigma_{ct}, \sigma_{cw}, \sigma_{tw}$)

In tension area with no bonded reinforcement ($\sigma_t \leq 3\sqrt{f_c}$ or 200psi) AASHTO 96, Art 9.15.2.1

Where f_c is concrete strength psi

For post tensioned member..... $\sigma_{ct} = 0.55 f_{ci}$ Art. 9.15.2.1

For load comb.(DL+LL+SL) $\sigma_{cw} = 0.6 f_{ci}$ Art. 9.15.2.2 a

For load comb.(DL+P) $\sigma_{cw} = 0.4 f_{ci}$ Art. 9.15.2.2 c

5.2.2. Ultimate Strength Constraint

$$M_{ult} \leq M^u \tag{5-9}$$

where M_{ult} -the ultimate design moment due to dead load, and live load considering the specified load factor.

M_u - the ultimate moment capacity of the section under consideration.

In general, we may determine beforehand the critical x-sections and loading condition geg (5.9) must be considered for the section selected, AASHTO code will be used to compute M^u .

Consider the following section.

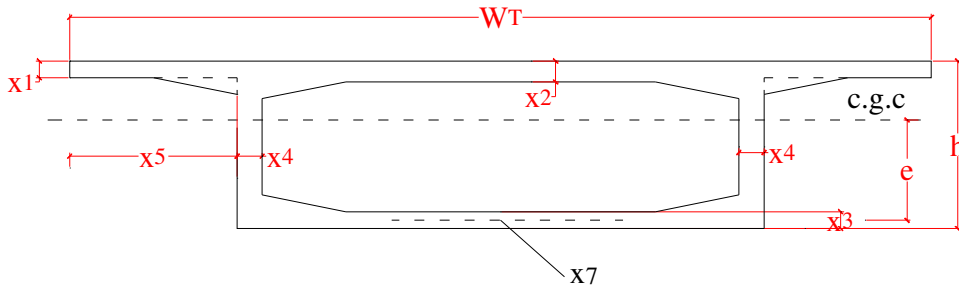

Fig. 5.3

Since X_1 and X_2 are design variable, which are allowed to have different value, it will be better to consider two cases for computing the ultimate moment capacity of the section.

AASHTO gives the following formula for computing moment capacity.

If $\frac{A_s f_{su}}{0.85 t_c b} \leq t_f$ (i.e. neutral axis with in the compressible flange, rectangular stress block)

$$\phi M_n = \phi \left\{ A_s \times f_{su} \times d \left[1 - 0.6 \frac{p \times f_{su}}{f_c} \right] \right\} \quad \text{AASHTO 96}$$

Art.9.17.2

If $\frac{A_s f_{su}}{0.85 f_c b} > t_f$ (T-shape stress block)

$$\phi M_n = \phi \left\{ A_{sr} \times f_{su} \times d \left(1 - 0.6 \frac{A_{sr} \times f_{su}}{b \times d \times f_c} \right) + 0.85 f_c (b - b') t_f \left(d - \frac{t_f}{2} \right) \right\} \quad \text{Art.19.17.3}$$

where ϕ - load factor

M_n - ultimate moment capacity

f_{su} - is average stress in pre stressing steel at ultimate load

$$p^* = \frac{A_s}{b \times d}$$

b - flange width

b' - web width

t_f - thickness of flange

d - effective depth

$$f_{su} = f_s \left(1 - \frac{\gamma^*}{\beta_1} \times p^* \times \frac{f_s}{f_c} \right) \text{ where } \gamma^* - \text{factor for type of pre stressing steel}$$

β_1 - factor for concrete

$$A_{sr} = A_s - A_{sf}$$

$$A_{sf} = 0.85 f_c (b - b') \frac{t_f}{t_{su}}$$

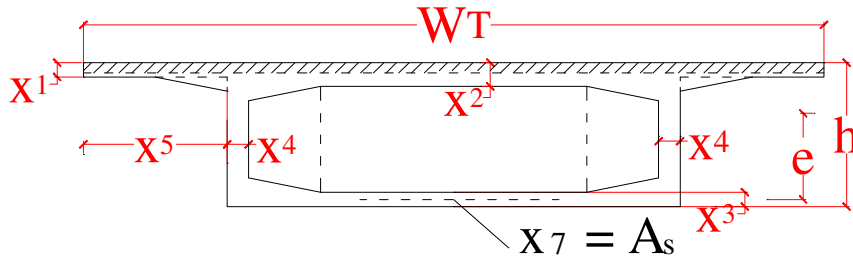

Fig. 5.4

Case I. If $x_1 \leq x_2$

i) If $\left(\frac{x_7 \times f_{su}}{0.85 f_c \times w_t} \leq x_1 \right)$ see fig

$$p^* = \frac{x_7}{W_T * d}$$

$$\phi M_n = \phi \left\{ x_7 \times f_{su} \times d \left(1 - 0.6 p^* \frac{f_{su}}{f_c} \right) \right\} \quad (5-10)$$

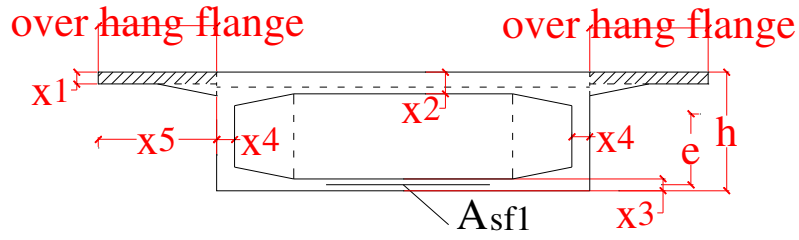

Fig. 5.5

$$\text{ii) If } \left(\frac{x_7 \times f_{su}}{0.85 f_c \times W_T} > x_1 \right)$$

$$A_{sf1} = 0.85 f_c (2x_5) \times \frac{x_1}{f_{su}}$$

$$A_{sr} = x_7 - A_{sf1}$$

$$\text{if } \frac{(A_{sr} * f_{su})}{0.85(W_T - 2x_5)d} \leq x_2, \text{ then}$$

$$p^* = \frac{A_{sr}}{(W_T - 2x_5)d}$$

The ultimate moment capacity is given by

$$\phi M_n = \phi \left\{ A_{sr} \times f_{su} \times d \left(1 - 0.6 \frac{A_{sr} \times f_{su}}{(W_T - 2x_5)d \times f_c} \right) + 0.85 f_c (2x_5) x_1 \left(d - \frac{x_1}{2} \right) \right\} \quad (5-11)$$

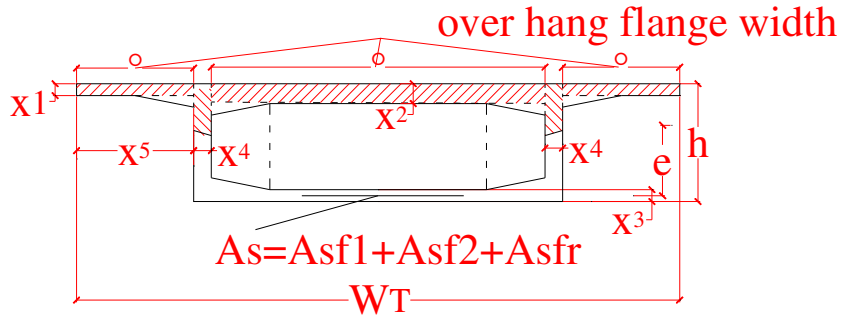

Fig. 5.6

but if $\left(\frac{A_{sr} f_{su}}{0.85 f_c (WT - 2x_5)} > x_2 \right)$, then

A_{sr} becomes

$$A_{sr} = x_7 - A_{sf1} - A_{sf2}$$

where, $A_{sf2} = 0.85 f_c (WT - 2x_4 - 2x_5) x_2 / f_{su}$

The ultimate moment capacity is given by

$$\phi M_n = \phi \left\{ A_{sr} f_{su} d \left(1 - 0.6 \frac{A_{sr} \times f_{su}}{2x_4 \times f_c \times d} \right) + A_{sf1} \left(d - \frac{x_1}{2} \right) f_{su} + A_{sf2} \times f_{su} \left(d - \frac{x_2}{2} \right) \right\} \text{--- Eq5.12}$$

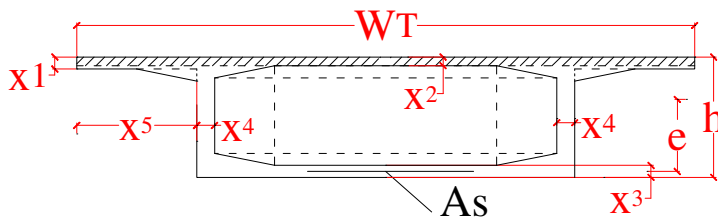

Fig. 5.7

Case II $x_1 > x_2$

$$i) \text{ if } \left(\frac{x_7 f_{su}}{0.85 f_c W_T} \leq x_2 \right)$$

$$p^* = \frac{x_7}{W_T * d}$$

$$\phi M_n = \phi \left\{ x_7 f_{su} d \left(1 - 0.6 \frac{P^* f_{su}}{f_i} \right) \right\}$$

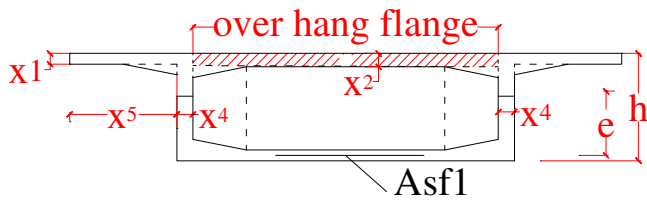

Fig 5.8

$$ii) \text{ if } \left(\frac{x_7 f_{su}}{0.85 (f_c W_T)} > x_2 \right)$$

$$A_{sr} = x_7 - A_{sf1}$$

$$A_{sf1} = 0.85 f_c (W_T - 2x_4 - 2x_5) * x_2 / f_{su}$$

$$\phi M_n = \phi \left\{ A_{sr} \times f_{su} \times d \left(1 - 0.6 \frac{A_{sr} \times f_{su}}{2(x_4 + x_5) d \times f_c} \right) + A_{sf1} \times f_{su} \left(d - \frac{x_2}{2} \right) \right\} \quad (5-13)$$

$$\text{if } \left(\frac{A_{sr} * f_{su}}{0.85 (2(x_4 + x_5)) f_c} \leq x_1 \right) \text{ then}$$

$$P^* = \frac{A_{sr}}{2(x_4 + x_5) \times d}$$

if $\left(\frac{A_{sr} * f_{su}}{0.85(2(x_4 + x_5)) f_c} > x_1 \right)$ then

$$A_{sr} = x_7 - A_{sf1} - A_{sf2}$$

where, $A_{sf2} = 0.85 f_c (2x_5) x_1 / f_{su}$

$$P^* = \frac{A_{sr}}{2x_4 * d}$$

$$\phi M_n = \phi \left\{ A_{sr} f_{su} d \left(1 - 0.6 \frac{A_{sr} f_{su}}{2x_4 f_c d} \right) + A_{sf1} f_{su} \left(d - \frac{x_2}{2} \right) + A_{sf2} f_{su} \left(d - \frac{x_1}{2} \right) \right\} \quad (5-14)$$

The fillet contribution is ignored to avoid complication so

$$M_{ult} = \gamma(\beta_d(M_G + M_s) + \beta_L M_{LL})$$

γ, β' sare load factor

$$\left. \begin{array}{l} \gamma = 1.3 \\ \beta_d = 1.0 \\ \beta_L = 1.3 \end{array} \right\} \text{is assumed} \text{ --- AASHTO96, Art, 3.22}$$

SO

$$M_{ult} \leq \phi M_n$$

$$G_6(x) = M_{ult} - \phi M_n \leq 0$$

5.2.3. Maximum Prestressing Steel Constrains

$$w \leq w^u$$

where w - Reinforcement index

w^u - Upper bound to Reinforcement index

This constraint ensure the steel by yielding as the ultimate capacity is approached

AASHTO give the following formula for calculating reinforcement index (w)

$$w = \frac{P^* f_{su}}{f_c^1}$$

For p^* value, check section 5.2.2 for the cased considered there

And $w'' = 0.36\beta_1$ -----AASHTO 96, Art 9.18

Therefore

$$w - w'' \leq 0 \Rightarrow \frac{P^* f_{su}}{f_c^1} - 0.36\beta_1 \leq 0$$

$$G_7(x) = \frac{P^* f_{su}^*}{f_c^1} - 0.36\beta_1 \leq 0$$

5.2.4. Minimum Prestressing Steel

AASHTO limit the minimum value of pre stressing steel to be used in pre stressing concrete section. The pre stressing steel in a section should be adequate to develop ultimate moment at critical section at least 1.2 times the cracking moment M_{cr}^* .

$$\phi Mn \geq 1.2M_{cr}^* \dots\dots\dots \text{AASHTO96 Art, 9.18.2.1} \quad (5-14)$$

where, $M_{cr}^* = (f_r + f_{pe}) \frac{I_c}{y_b} - M_G$

$$M_{cr}^* = (f_r + f_{pe}) \frac{A_c r_2}{y_b} - M_G$$

$$M_{cr}^* = (f_r + f_{pe}) A_c K_t - M_G \dots\dots\dots (5-15)$$

$$f_{pe} = \frac{f_{se} x_7}{A_c} + \frac{f_{se} x_6 x_7}{A_c K_t} \quad (5-16)$$

f_r – is modulus of rupture

f_{pe} – effective stress

Substituting Eq 5.16 in to Eq5.15 gives:-

$$M_{cr}^* = f_r A_c K_t + f_{se} x_7 K_t + f_{se} x_6 x_7 - M_G \quad (5-17)$$

Putting 5-17 in to Eq5.14 and simplifying gives

$$G_8(x) = 1.2(f_r A_c K_t + f_{se} x_7 K_t + f_{se} x_6 x_7 - M_G) - \phi M_n \leq 0$$

5.2.6. Deflection Constraints:-

$$D \leq D^u \quad (5-18)$$

where D –is the deflection of the girder under load

Du – the upper bound to deflection

AASHTO limit deflection under service load including impact to be less or equal to $1/800$ of the span.

$$Du = \frac{L}{800} \quad \text{AASHTO 9.11.3.2}$$

where L-span of the girder

Assume the following tendon profile for the girder selected

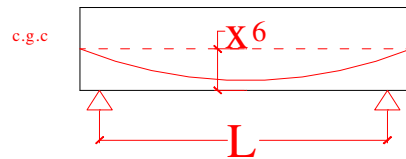

Fig. 5.10

Fig. 5.10

The deflection at mid span is given by

$$D = -\Delta_p + \Delta_{D.L} + \Delta_s + \Delta_{LL} \dots \dots \quad (5-19)$$

where Δ_p - Camber due to effective pre stress

$\Delta_{D.L}$ - Deflection due to dead load

Δ_s - Deflection due to super imposed load

Δ_{LL} - Deflection due to live load

Deflection due to effective pre stress at mid span (For parabolic tendon profile)

$$\Delta_p = \frac{L^2}{8E_c I_c} \left(\frac{5}{6} f_{se} \times x_6 \times x_7 \right)$$

Deflection due to dead load

$$\Delta_{D.L} = \frac{L^2}{8E_c \times I_c} \left(\frac{5}{6} M_G \right)$$

Deflection due to super imposed load

$$\Delta_s = \frac{L^2}{8E_c \times I_c} \left(\frac{5}{6} M_s \right)$$

Deflection due to live load:

For long span lane load loading give maximum deflection.

Deflection due to uniform load in lane loading (W_{LL})

$$\Delta_{W_{LL}} = \frac{L^2}{8E_c \times I_c} \left(\frac{5}{6} \frac{W_{LL} \times L^2}{4} \right)$$

Deflection due to concentrated load in lane loading (P_{LL})

$$\Delta_{P_{LL}} = \frac{L^2}{8E_c \times I_c} \left(\frac{5}{6} \frac{P \times L}{4} \right)$$

Deflection by sustained load will increase with time due to creep effect, so creep coefficient must be included in computing deflection under these load.⁽¹⁾

So the following creep coefficient are assumed⁽¹⁾

For pre stress deflection – 2.4

Dead load deflection – 2.7

Super imposed load deflection – 3.0

There fore:-Deflection at mid span under service load will be:-

$$D = \left(-2.45 * \frac{5}{6} f_{se} \times x_6 \times x_7 + 2.7 \times \frac{5}{6} M_G + 3.0 \times \frac{5}{6} M_s + \frac{5}{6} \frac{W_{LL} \times L^2}{8} + \frac{2}{3} \frac{PL}{4} \right) \frac{* L^2}{8E_c \times I_c}$$

$$G_9(x) = \frac{L^2}{8E_c \times I_c} \left(\begin{array}{l} -2.45 * \frac{5}{6} f_{se} \times x_6 \times x_7 + 2.7 * \frac{5}{6} M_G + \\ 3.0 * \frac{5}{6} M_s + \frac{5}{6} \frac{W_{LL} \times L^2}{8} + \frac{2}{3} \frac{P \times L}{4} \end{array} \right) - \frac{L}{800} \leq 0$$

5.2.6. Transverse Bending Strength Constraint

$$M_{ultT} \leq \phi M_{nT}$$

Where M_{ultT} – ultimate design moment in transverse direction.

M_{nT} – ultimate moment capacity in transverse direction.

The girder selected, is pre stressing in longitudinal direction and reinforced in transverse direction. And the critical section for transverse direction is assumed to be at face of the cantilever (fig.5.11)

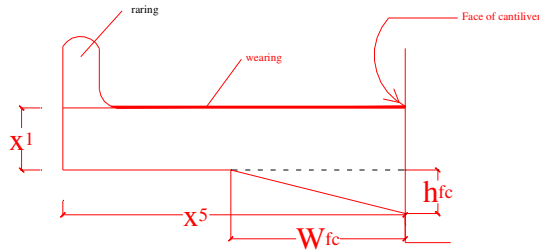

Fig. 5.11

The ultimate moment capacity for reinforced concrete section is given by.

$$\phi M_{nc} = \phi \left\{ A_r \times f_y \times d \left(1 - 0.6 \frac{\rho \times f_y}{f_c} \right) \right\} \text{----- AASHTO96, Art 8.16.3.2.2}$$

Where A_r – Area of reinforcement depth

f_y – Tensile strength

d – Effective depth

ρ – Reinforcement ratio

M_{nc} – Moment capacity of the section.

For this case assume ρ to be used equal to ρ_{max} .

Where $\rho_{max} = 0.75 \rho_b$ AASHTO96,Art8.16.3.1.1

$$\rho_b = \frac{0.85 \beta_1 \times f_c}{f_y} \left(\frac{87,000}{87,000 + f_y} \right) \text{.....AASHTO, Art,8.16.3.2.2}$$

$$d = x_1 - 5cm(\text{cover})$$

The ultimate design moment at the face of the cantilever can be calculated as follows

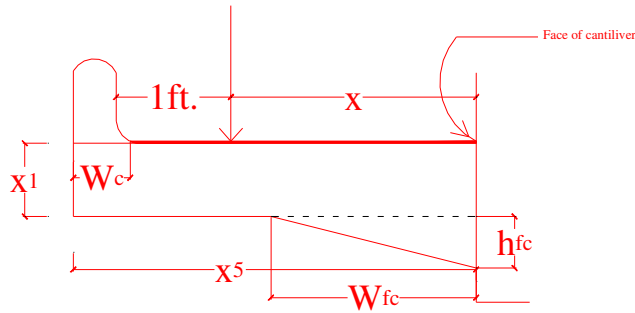

Fig. 5.12

Dead Load Moment

$$M_{GC} = \frac{\gamma_c \times x_1 \times x_5^2}{2} + \frac{\gamma_c \times h_{fc} \times w_{fc}^2}{3}$$

Super imposed moment

$$M_{sc} = \frac{W_{ss} x_5^2}{2} + w_R * x_5$$

where W_{ss} -unit weight of wearing surface per unit area

W_r - railing weight per length

Live load moment

Distributing width

$$E = 0.8X + 3.75 \dots\dots X \text{ in ft} \dots\dots \text{AASHTO96} \dots\dots \text{Art.3.24.5.1.}$$

$$E = 0.8X + 1.143 \dots\dots X \text{ in meter}$$

$$M_{LLc} = \left(\frac{P_{20}}{E} \right) x = \frac{71.168 \times x}{E}$$

For the range allowed impact > 0.3

So take impact = 0.3

$$impact = \frac{15.24}{x + 38.1}$$

$$M_{LL1} = \frac{1.3 * 71.168 * x}{E}$$

$$\text{Take } \gamma=1.3 \quad \beta_d=1 \quad \beta_L=1.67$$

$$M_{ult} = \gamma(\beta_d(M_{Gc} + M_{sc}) + \beta_L M_{LLc})$$

$$M_{UHC} = 1.3(M_{Gc} + M_{sc} + 1.67M_{LLc})$$

$$G_{10}(x) = M_{UHC} - \phi M_{nc} \leq 0$$

5.2.7. Design Constraints

These constraints might reflect, the minimum practical dimension for construction, architectural consideration, code restriction or designed relation ship between design variable. This constraint are given as

$$x^L \leq x \leq x^u$$

where x - the design variable

x^L – Lower bound to the design variable

x^u – Upper bound to the design variable

For this optimal design problem, the following design constraint are considered

$$G_{11}(x) = x_1 + h_{fc} - 70cm \leq 0$$

$$G_{12}(x) = h_{fc} - x_1 \leq 0$$

$$G_{13}(x) = \left\{ \begin{array}{l} \frac{WT - 2(x_4 + x_5 + W_{ff})}{30} \\ \text{or } 20.0cmx_2 \leq 0 \end{array} \right\} - x_2 \leq 0$$

$$G_{14}(x) = \left\{ \begin{array}{l} \frac{WT - 2(x_4 + x_5 + W_{ff})}{30} \\ 20.0cm - x_3 \leq 0 \end{array} \right\} - x_3 \leq 0$$

$$G_{15}(x) = 25cm - x_4 \leq 0$$

$$G_{16}(x) = 2h_{ff} - (H - x_2 - x_3) \leq 0$$

$$G_{17}(x) = 2w_{ff} - (WT - 2(x_4 + x_5)) \leq 0$$

$$G_{18}(x) = 175cm - x_5 \leq 0$$

$$G_{19}(x) = x_5 - 275cm \leq 0$$

$$G_{20}(x) = x_6 - (H - Y_c - 10cm) \leq 0$$

5.3 Objective Function

The objective function, in this case, represents the cost of material and pre stressing.

$$Z = C_c A_c + C_p x_7$$

where C_c - Unit cost per unit area of concrete

C_p - Unit cost per unit area of pre stressing steel

A_c . Area of concrete section

x_7 . Area of prestressing steel

Area of the concrete section for the section taken in this formulation is given by

$$A_c = 2x_1 \times x_5 + H \times (W_T - 2x_5) - (H - x_2 - x_3) \times (W_T - 2 \times (x_4 + x_5)) \\ + W_{fc} \times H_{fc} + 2W_{ff} \times H_{ff}$$

and the objective function (Z) becomes

$$Z = C_c \times [2x_1 \times x_5 + H \times (W_T - 2x_5) - (H - x_2 - x_3) \times (W_T - 2 \times (x_4 + x_5))] \\ + W_{fc} \times H_{fc} + 2W_{ff} \times H_{ff} + C_p \times x_7$$

CHAPTER SIX

Numerical Examples

In this section ,a numerical example is given to optimize a box girder bridge subjected to the constraints developed in section 5. A simply supported bridges which has a rectangular cross section ,as assumed while developing the constraints in section 5 is considered.for this numerical example a bridge which has 40m span is considered.

A fortran program based on a feasible direction method is developed to solve the problem at hand .I n the program the span of the bridge is inserted as in put so that the program can be used to optimize bridges having different spans

In the example ,the following variables are taken as preassigned parameters (see fig. 6.1) and their assumed values are: -

$$\begin{array}{ll} W_T = 1030\text{cm} & W_{FF} = 100\text{cm} \\ H = 200\text{cm} & H_{FC} = 100\text{cm} \\ W_{FC} = 100\text{cm} & H_{FC} = 100\text{cm} \end{array}$$

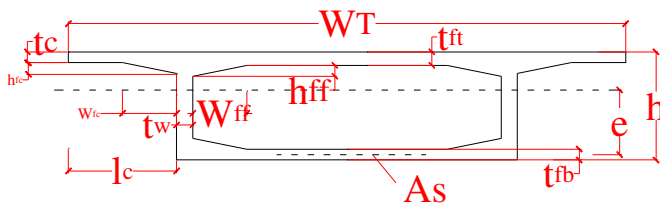

Fig. 6.1

And the design variable are the same as those variable taken as design variable in formulating the optimization problems in section 5.1

The following material properties are assumed in the example

Concrete: -

$$\begin{array}{l} f_{ci} = 27.558\text{MPa} \\ f_c = 34.472\text{MPa} \end{array}$$

$$E_c = 27787.9\text{MPa}$$

$$\beta_1 \text{ (strength factor) } = 0.8$$

$$\gamma_c = 24\text{KN/m}^3$$

Pre Stressing Steel

$$F_s = 1860\text{Mpa}$$

Low relaxation steel with strength factor $\gamma^* = 0.28$

Reinforcement Steel In Transverse Direction

$$F_y = 300\text{Mpa}$$

$$E_s = 200,000\text{Mpa}$$

In the example, all losses except frictional loss are generally estimated to be 33,000 psi (AASHTO) and frictional loss is calculated independently tendons profile (C.g.s along the length) are assumed to e parabolic with maximum eccentricity at critical section and zero eccentricity at the ends

And frictional loss is calculated at mid span using the following formula

$$f_i = f_j \times e^{-(KL+\mu\alpha)} \quad (6-1)$$

where f_j – Jacking force at end

K – Wobble coefficient

μ - Coefficient of friction

α -change in angle from end to mid span

and α is approximated by

$$\alpha = \frac{4x_6}{L}$$

Critical Section

Generally, for long span bridge, where the ratio of the dead load moment otthe live load moment or the total moment is high, the critical section for flexure for simply supported beam will be at midspan. And in this example, the critical section is taken to be the mid span since the span (40m) considered is so long.

Live Load Moment At Mid Span

For live load moment determination Hs-20 truck loading and same loadings are considered

Truck loading

The position of the axle load shown in figure 6-3 gives the maximum design live load at mid span.

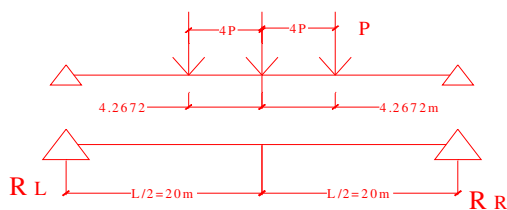

Fig. 6.2

Reaction at left and given as

$$R_L = \left(4p \left(\frac{L}{2} + 4.2672 \right) + 4p \left(\frac{L}{2} \right) + P \left(\frac{L}{2} - 4.2672 \right) \right) / L$$

$$R_L = 4.5P + 12.8016 P/L$$

Moment at mid span is

$$M_{LL} = R_L (L/2) - 4P (4.2672)$$

$$= \frac{4.5PL}{2} + \frac{12.8016P}{2} - 17.0688P$$

$$= 2.25PL - 10.668P$$

Where $P = 35.584 \text{ KN} = 3.5584 \text{ t}$

So for $L = 40 \text{ m}$

$$M_{LL} = 282.295$$

Loading two lane

$$M_{LL} = 564.590$$

Impact

$$I = \frac{15.24}{L + 38.1} = \frac{15.24}{40 + 38.1} = 0.195 \leq 0.3$$

So $I = 0.195$

So $M_{LL+I} = 564.59 * (1+0.195) = 674.761 \text{tm}$

Lane Loading: -

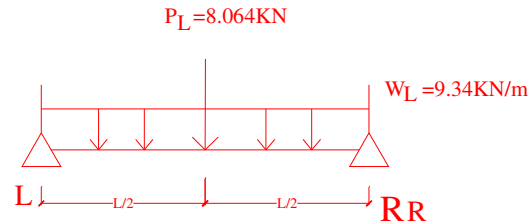

Fig. 6.3

Maximum live load moment at mid span is given by

$$M_{LL} = \frac{W_L * L^2}{8} + \frac{P_L * L}{4}$$

$$M_{LL} = 2668.64 \text{ kNm}$$

For two lane loading

$$M_{LL} = 2 * 2668.64 \text{ kNm} = 5337.28 \text{ kNm}$$

Including impact

$$M_{LL+I} = (1 + 0.195) * 5337.28 \text{ kNm}$$

Therefore the HS-20 Truck loading govern the design.

Optimization Method

Due to Large number (twenty) of constraint feasible direction method which could be used to solve any non-linear optimization problem is chosen for this numerical method was discussed in detail in chapter five so it is generally recommended refer back.

Computer program

A fortran program is written for a feasible direction method to solve the example problem the program written could be used to search the optional solution for span length other than the span considered in this numerical example. It is only required to change (modify) the in put data to use the program for other span.

In the program, the cross-sectional property of the bridges is calculated assuming the cross-section is to be divided as shown in fig 6-4 and the property of the whole section are determined based on the properties of the segments.

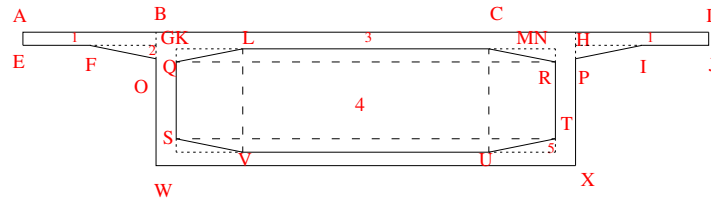

Fig. 6.4

Segment 1 - ABGEA

Segment 2 - FGOF

Segment 3 - BCXWB

Segment4 - KNYZK

Segment5 - KLQK

Constraint gradients

Gradient of the first constraint (∇G_1) is evaluated here as an examples

$$G_1 = -k_b + x_6 - \frac{M_G}{f_i \times x_7} - \frac{\sigma_u \times A_c \times k_b}{f_i \times x_7}$$

The dead load moment M_G can be written interms of section area (A_c) as follows

$$M_G = \frac{\gamma_c \times A_c \times L^2}{8}$$

Let $C = \frac{\gamma_c \times L^2}{8}$

So $M_G = C \times A_c$

Therefore, G_1 is given by

$$G_1 = -k_b + x_6 - \frac{A_c \times (C + \sigma_u \times k_b)}{f_i \times x_7}$$

partial derivatives of G_1 with respect to x_j is given as

$$\frac{\partial G_1}{\partial x_j} = -\frac{\partial k_b}{\partial x_j} + \frac{\partial x_6}{\partial x_j} - \frac{1}{(f_i \times x_7)^2} \left[\begin{array}{l} f_i \times x_7 \left((C + \sigma_u \times k_b) \times \frac{\partial A_c}{\partial x_j} + \sigma_u \times A_c \times \frac{\partial k_b}{\partial x_j} \right) \\ - A_c \times (C + \sigma_u \times k_b) \times \frac{\partial (f_i \times x_7)}{\partial x_j} \end{array} \right] \quad (6-2)$$

From Eq. 6-1, f_i is a function of x_6 only

Therefore,

For $j=1 \dots 5$ Eq. 6-2 becomes

$$\frac{\partial G_1}{\partial x_j} = -\frac{\partial k_b}{\partial x_j} - \frac{1}{(f_i \times x_7)^2} \left[f_i \times x_7 \left((C + \sigma_u \times k_b) \times \frac{\partial A_c}{\partial x_j} + \sigma_u \times A_c \times \frac{\partial k_b}{\partial x_j} \right) \right]$$

$$\frac{\partial G_1}{\partial x_j} = -\frac{\partial k_b}{\partial x_j} - \frac{1}{(f_i \times x_7)} \left[(C + \sigma_u \times k_b) \times \frac{\partial A_c}{\partial x_j} + \sigma_u \times A_c \times \frac{\partial k_b}{\partial x_j} \right]$$

and

$$\frac{\partial f_i}{\partial x_6} = -4 \times \frac{\mu}{L} f_i$$

for $j=6$ Eq. 6-2 becomes

$$\frac{\partial G_1}{\partial x_6} = -\frac{1}{(f_i \times x_7)^2} \left[-A_c \times (C + \sigma_u \times k_b) \times \frac{\partial (f_i \times x_7)}{\partial x_6} \right]$$

$$\text{or } \frac{\partial G_1}{\partial x_6} = -4 \times \frac{\mu \times A_c \times (C + \sigma_u \times k_b)}{f_i \times x_7 \times L}$$

$$\text{and } \frac{\partial G_1}{\partial x_7} = \frac{A_c \times (C + \sigma_u \times k_b)}{f_i \times x_7^2}$$

Notation In The Program

W_{ff} - flange width in the box
 H_{ff} - flange height in the box
 W_{fe} - flange width at the cantilever
 H_{fe} - flange height at the cantilever
 W_t - total width of the girded deck
 H - total depth of the girder
 $A(I)$ - segmented Area I
 $YA(I)$ - segmented area centered from top fiber
 A_c - total area of the section
 Y_c - centered of the section from top fiber
 I_c -Moment of Inertia of segment I about its own centered
 K_T - Top kern
 K_B - Bottom Kern
 W_{ss} - unit weight of wearing surface per unit area
 W_R - unit weight of raring per unit length
 M_G - Dead load moment
 M_u - live load moment +Impact
 M_T - Total Moment ($M_G+M_s+M_{LL}$)
 S_p - span of the girder
 F_s - strength of pre stressing steel
 F_I - stress in pre stressing steel at mid span at transfer
 F_{se} - effective stress in steel at mind span
 B_s - (factor for steel type
 U_{wc} - unit weight of concrete
 F_c - strength of concrete
 E_c - Modulus of elasticity of concrete
 B_i - strength factor for concrete
 T_F - Thickness of flange
 B_W - thickness of web
 D - effective depth of the girder
 A_{st} - flange reinforcement
 F_r - modulus of rupture

D_t - deflection due to service load
 R - reinforcement ratio (pre stress)
 F_{ci} - concrete strength at transfer
 F_y - reinforcement ratio strength
 E_s - modulus of elasticity of steel
 W_c - wobble coefficient
 M_{Gc} - Dead load moment at the cantilever face
 M_{sc} - super imposed moment at the cantilever face
 M_{uc} - live load moment at the cantilever face
 M_{uHc} - ultimate design moment at the cantilever face
 F_j - Jaking stress
 F_{TT} - allowable tensile stress at transfer
 F_{CT} - allowable comp stress at transfer
 F_{CW} - allowable comp stress at working load
 F_{TW} - allowable tensile stress at working load
 F_{co} - (frictional coefficient)
 F_{su} - average stress in pre stressing steel at ultimate load
 M_N - ultimate moment capacity
 M_{uH} - ultimate design moment
 M_{cr} - cracking moment
 $R_B - P_b$
 $R_{max} - P_{max}$

Partial derivative of with respect to x_i is noted by preceding the variable by letter d
 For example partial derivative of total area (A_c) with respect to X_i is noted by

$$DAC (I) = \frac{\partial A_c}{\partial x_i}$$

Partial derivative of the objective function with respect to x_1

$$GRDZ (I) = \frac{\partial f}{\partial X_i}$$

Partial derivative of the constraint I with respect to X_j

$$GRDg (I, J) = \frac{\partial G_i}{\partial X_j}$$

G(J) - J constraint

S(I) - Feasible direction

SUBROUTINE GRAOBJ () will calculate the gradient of objective function

SUBROUTINE GRAOBJ () will calculate the gradient of objective function

SUBROUTINE LINPRO () will search feasible direction if some constraint are active

FUNCTION COST (X) will calculate the value of the objective function.

Unit in the program

the following units are used in the program

- i) Cross-sectional properties in cm. Units
- ii) Span in m.
- iii) Loads in KN/m.
- iv) Moment in ton meter
- v) Stress in MPa.

The source code given in the appendix is used to solve this particular optimization problem.

The initial feasible point used.

X1 = 25 X2 = 25 X3 = 25 X4 = 30 X5 = 200 X6 = 105

X7 = 230

Conclusion

From the chart, it can be observed that

1. As iteration number increase, the values of x_1 (thickness of the cantilever flange), x_2 (thickness of the top flange), x_3 (thickness of the bottom flange) and x_4 (thickness of the web) are getting very close to 20cm (lower bound of x_1), 20cm (lower bound of x_2), 15cm (lower bound of x_3) and 25cm (lower bound of x_4), respectively.
2. As iteration number increased the value of x_6 (eccentricity of the tendon), which has not any contribution for the cost function, is increased.
3. As iteration number increased the value of x_7 (pre stressing steel area), is decreased.

There fore, from the above three observation, the following general conclusion could be made.

The optimal design for pre stressed concrete box-girder could be best approximated by the following step.

- i. For flanges and webs thicknesses, the side constraint are active i.e. they have the minimum value allowed by the codes.
- ii. Assume, the c.g.s. (center of gravity of the pre stressing area) to be located at the maximum practical distance possible from the centroid of the section which has flange and web thicknesses as assumed in (i).
- iii. Minimize the pre stressing steel area for cross-sectional dimension in (i) and eccentricity in (ii). This can be done by evaluating the minimum pre stressing steel area required for each constraint and taking the largest one.

Usually, the allowable tensile stress at bottom fiber under service load (g_4) or the maximum allowable deflection under service load (g_9) decide (govern) the value of the pre stressing steel area.

The mould used for manufacturing precast concrete segmental girder one standardized for depths of the girder. But if the girder depth is allowed to have any values, the depth can be taken as a design variable in the design problem

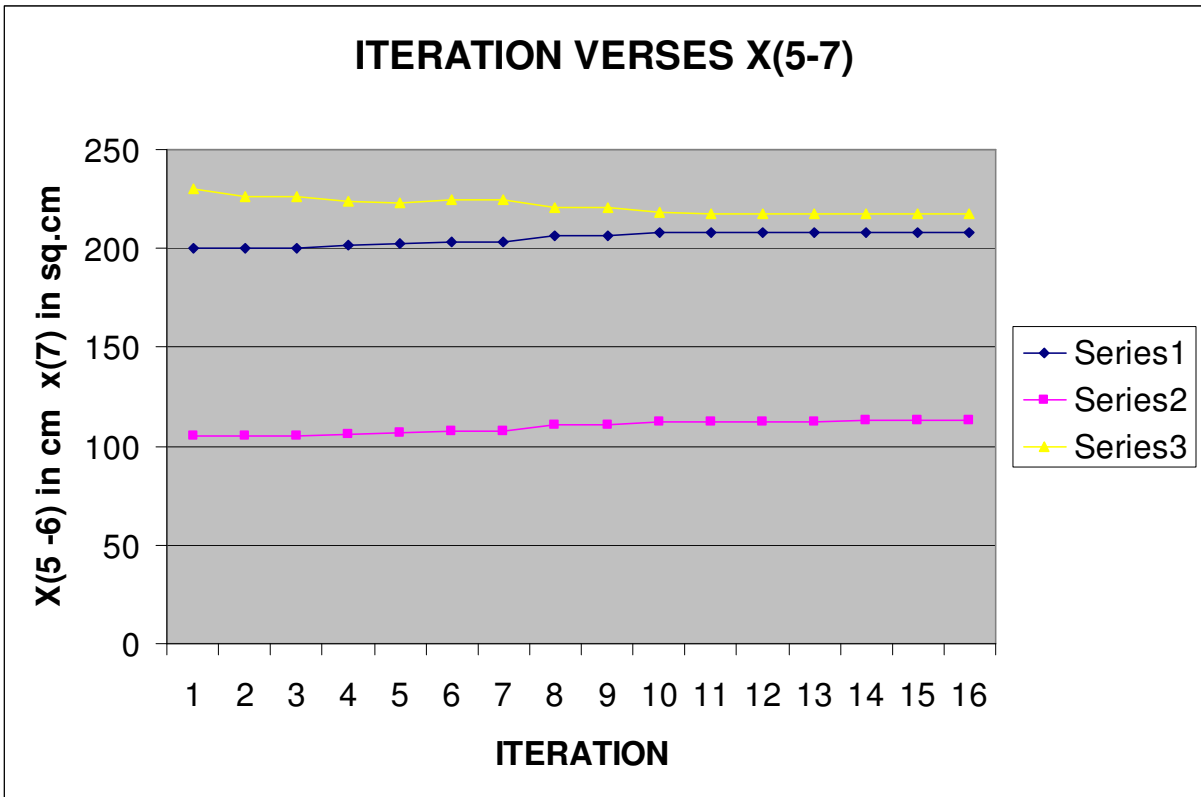

DATA USED IN OPTIMAZATION

CROSS SECTIONAL DATA

TOTAL WIDTH OF THE BRIDGE= 1030.000CM
 TOTALDEPTH OF THE GIRDER= 200.000CM
 SPAN =40.00M
 FILLET AT CANTILEVER
 FILLET WIDTH= 100.000CM
 FILLET DEPTH = 20.000CM
 FILLET IN THE BOX
 FILLET WIDTH= 100.000CM
 FILLET DEPTH= 20.000CM

MATERIAL DATA

CONCRETE
 UNIT WEIGHT= 24.00 KN/M3
 FCI= 27.558MPA
 FC= 34.472MPA
 EC= 27788.00MPA
 B1= .800

TENDON

FS=1860.000MPA
 = .280

FRICITIONAL LOSS COEFFIENT

LENGTH COEFFIENT= .0007
 FRICITIONAL COEFFIENT= .2000

LOAD

SUPERIMPOSED LOADS

ASPHALT 1 INCH THICH= .4310KN/M2
 RAILING= 11.5200KN/M

LIVE LOAD MOMENT= 674.9020TON METER

X1	X2	X3	X4	X5	X6	X7	Z
25.00	25.000	25.000	30.000	200.000	105.000	230.000	18280.0000
ITER=	1						
21.58	20.133	20.133	27.438	200.427	105.000	226.442	17172.1800
ITER=	2						
21.50	20.011	20.011	27.371	200.435	105.000	226.354	17144.3000
ITER=	3						
23.19	21.698	19.395	25.170	202.121	106.686	223.997	17090.1400
ITER=	4						
22.99	21.415	19.112	25.014	202.139	106.686	223.792	17025.2500
ITER=	5						
21.80	20.090	19.516	25.870	202.995	107.543	224.648	16976.1100
ITER=	6						
21.80	20.090	19.515	25.870	202.995	107.543	224.648	16976.1100
ITER=	7						
22.78	23.299	15.129	29.079	206.204	110.752	220.516	16848.4600
ITER=	8						
22.69	23.179	15.010	29.010	206.211	110.752	220.427	16820.8800
ITER=	9						
20.24	20.483	16.761	26.713	207.962	112.503	217.972	16416.6200
ITER=	10						
20.01	20.174	16.453	26.534	207.981	112.503	217.742	16345.1500
ITER=	11						
20.12	20.010	16.468	26.394	208.088	112.610	217.849	16339.8600
ITER=	12						
20.12	20.010	16.468	26.394	208.088	112.610	217.849	16339.8600
ITER=	13						
20.00	20.137	16.288	26.321	208.015	112.737	217.686	16320.0500
ITER=	14						
20.00	20.137	16.288	26.321	208.015	112.737	217.686	16320.0500
ITER=	15						
20.11	20.001	16.304	26.159	208.124	112.846	217.795	16316.0600
ITER=	16						

XOPT 1= 20.114
XOPT 2= 20.001
XOPT 3= 16.304
XOPT 4= 26.159
XOPT 5= 208.124
XOPT 6= 112.846
XOPT 7= 217.795
ZOPT= 16316.060

APPENDIX

Flow Chart
Main Program Flow

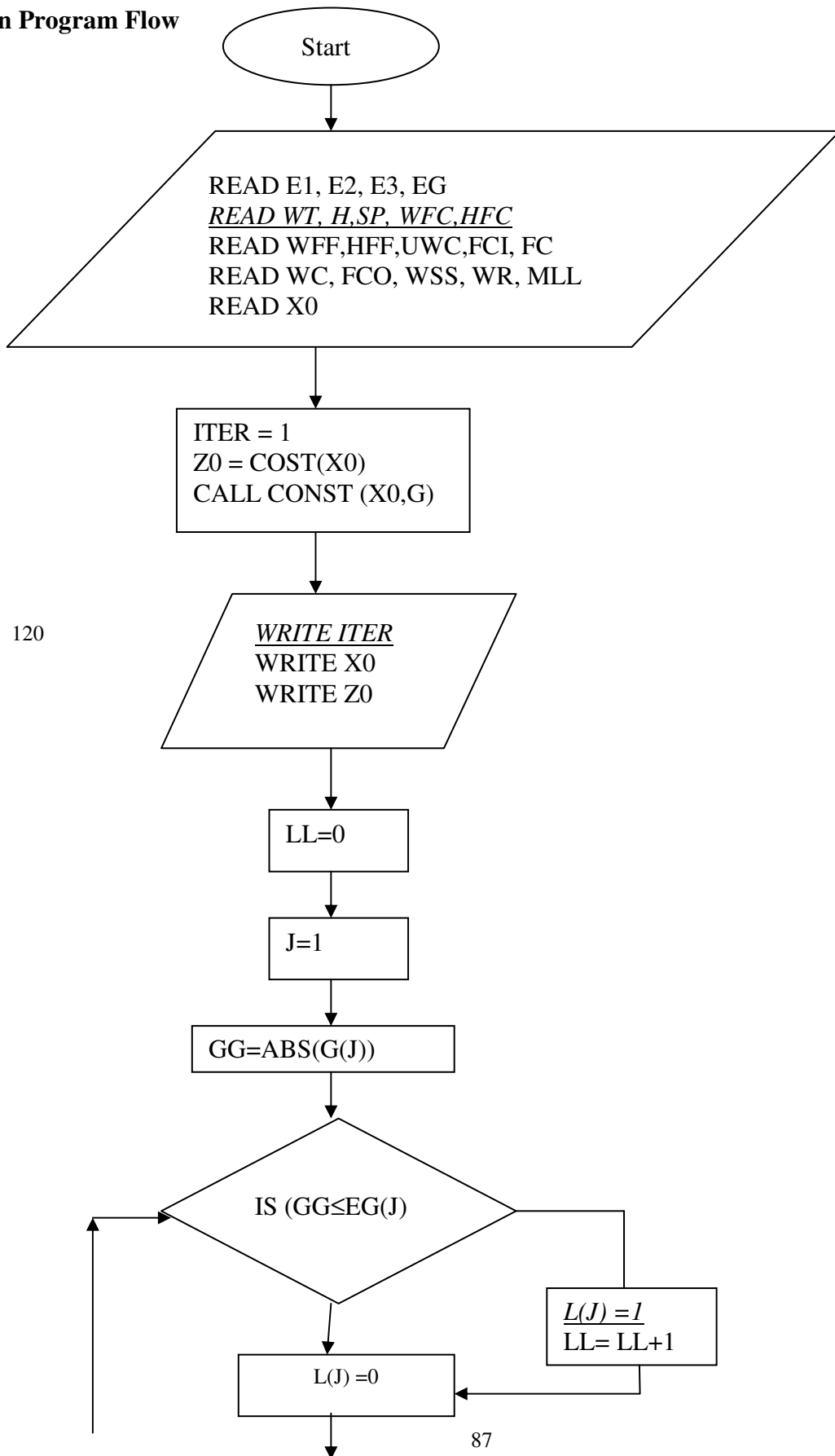

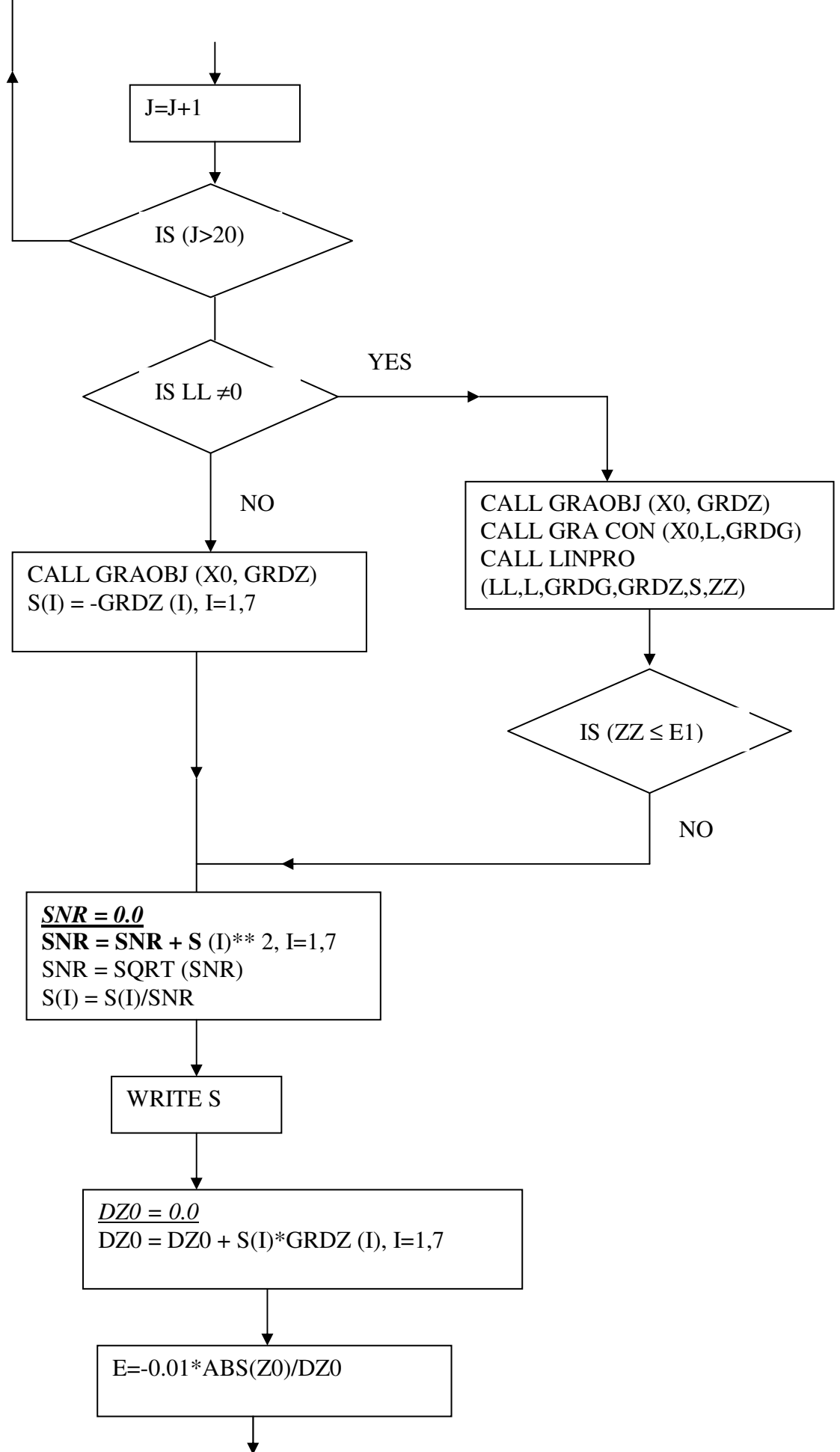

125

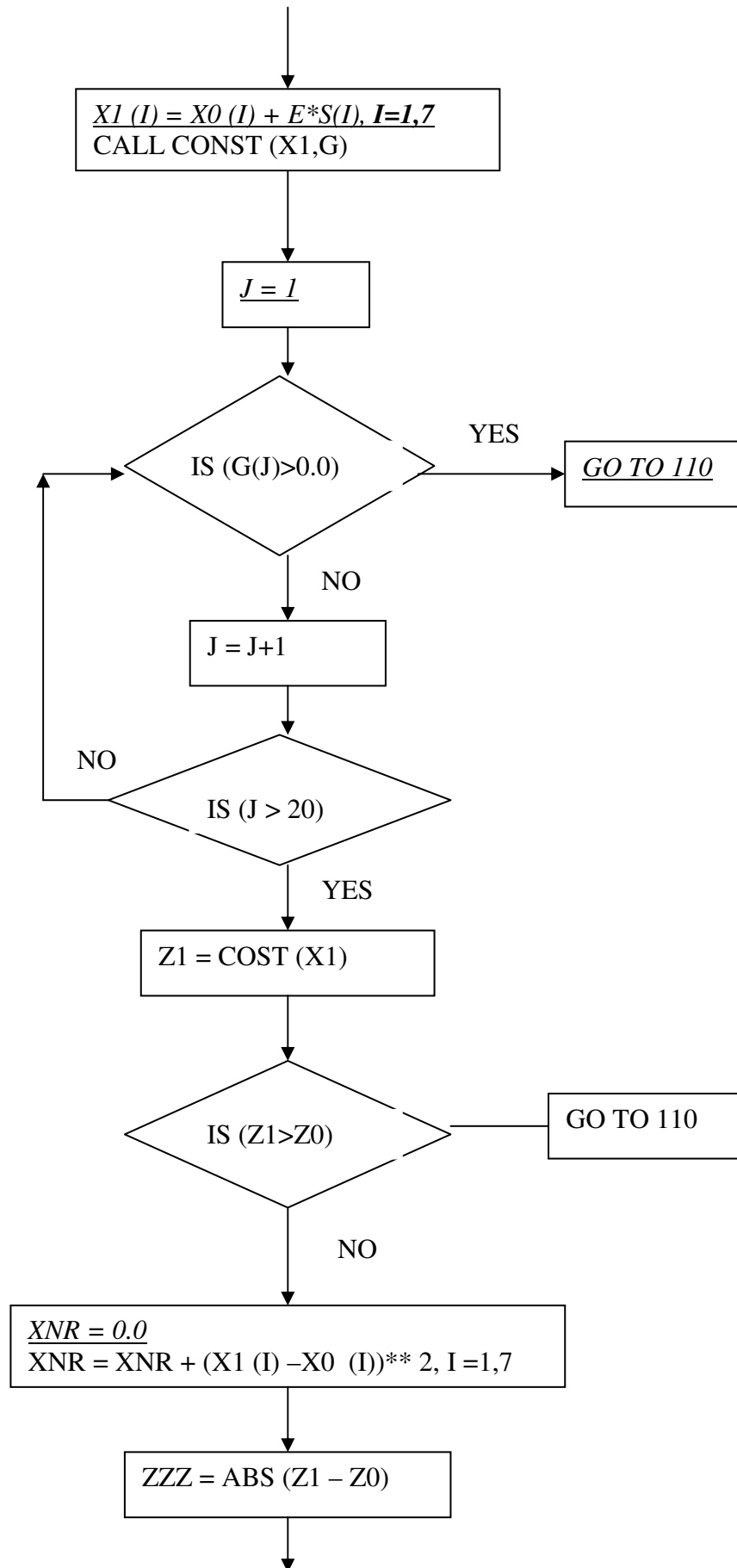

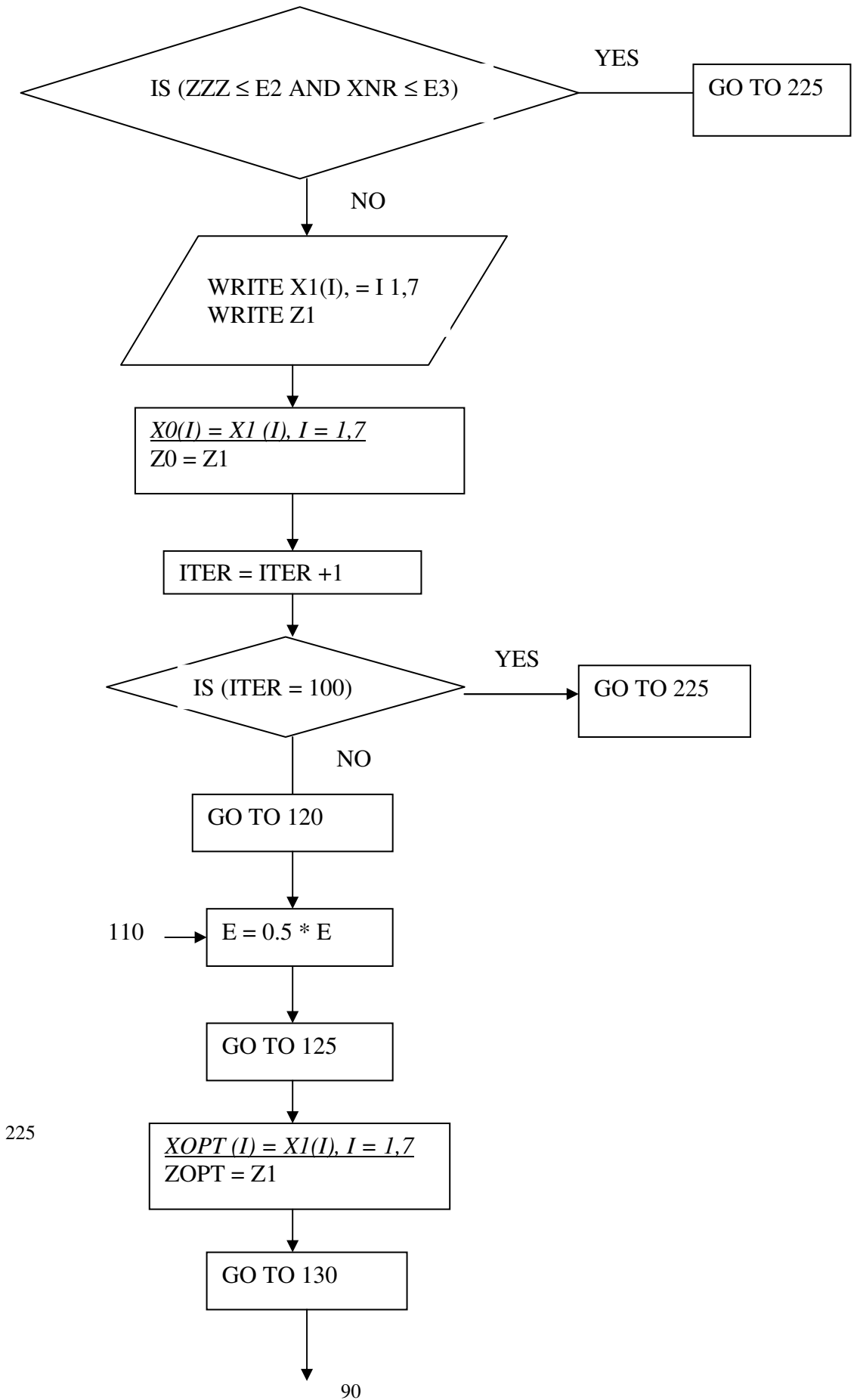

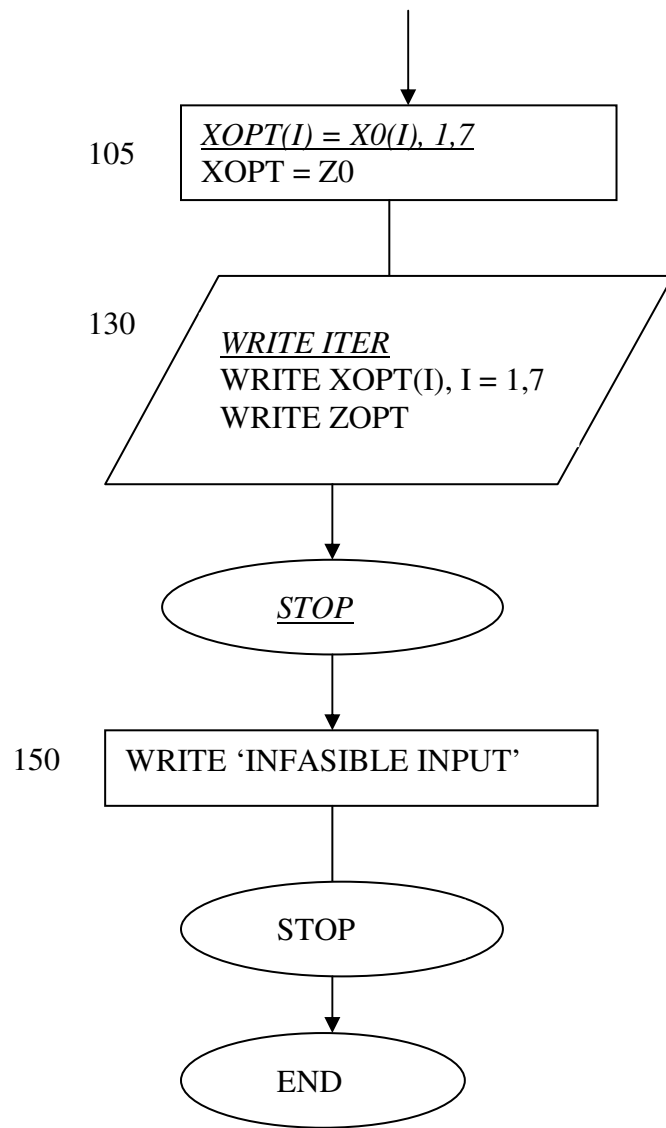

SUB ROUTINE GRACON

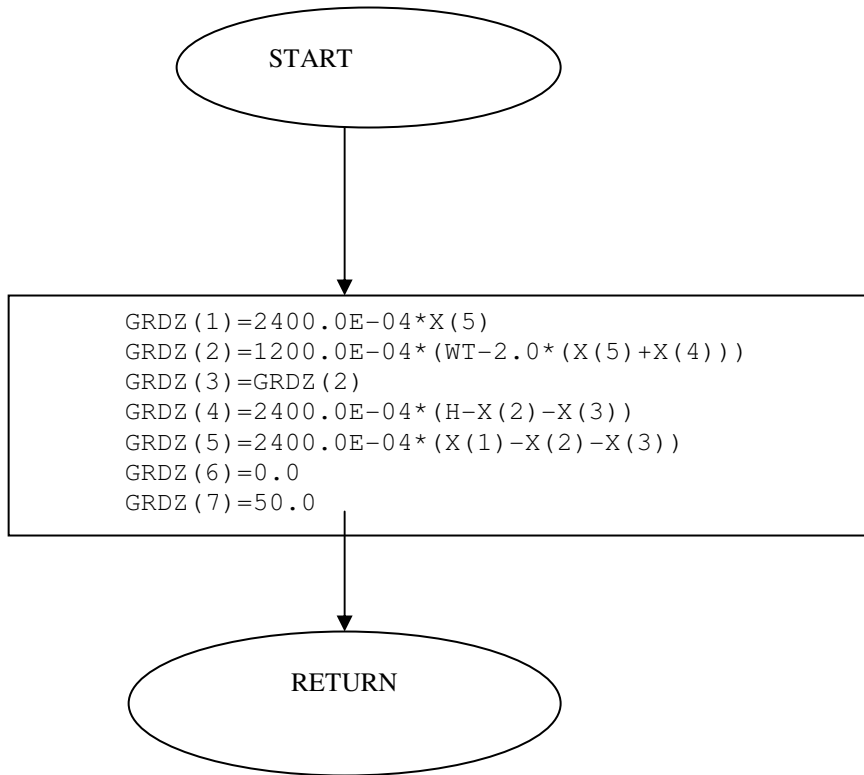

FUNCTION COST

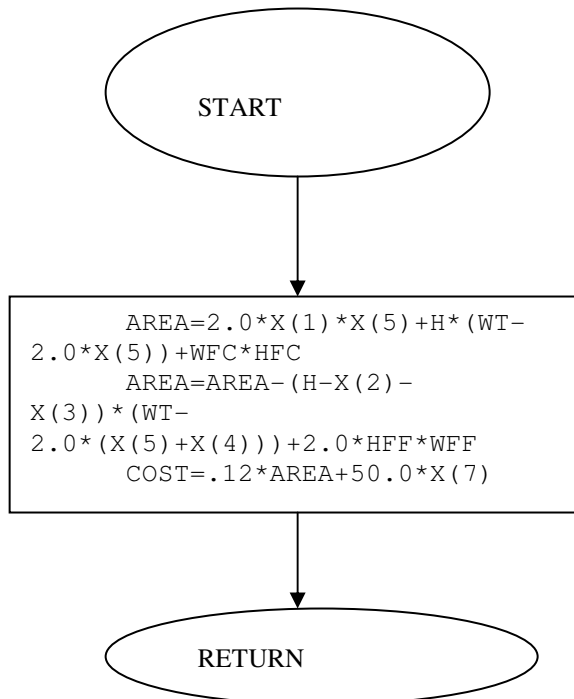

SUB ROUTINE CONST (X,G)

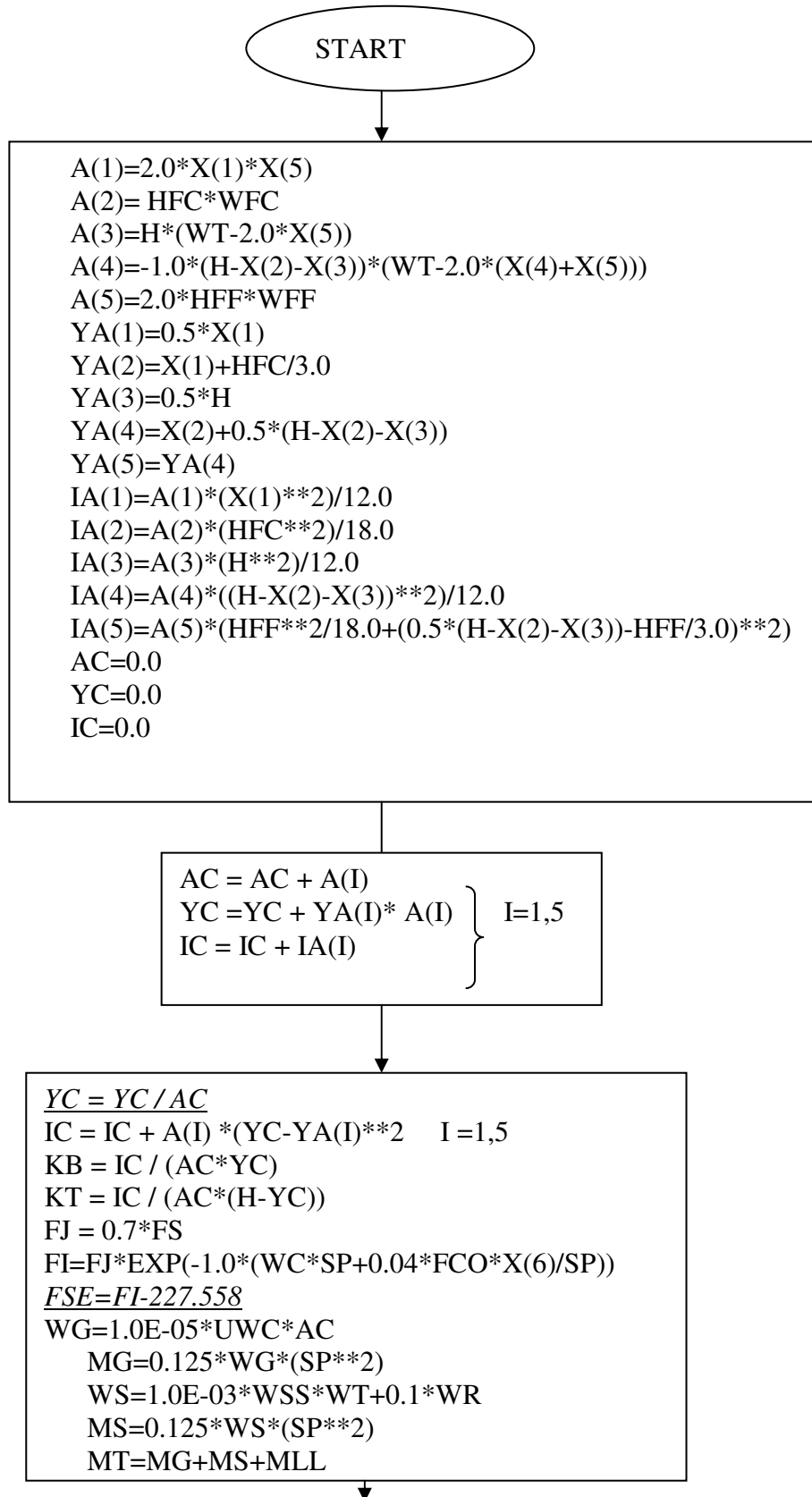

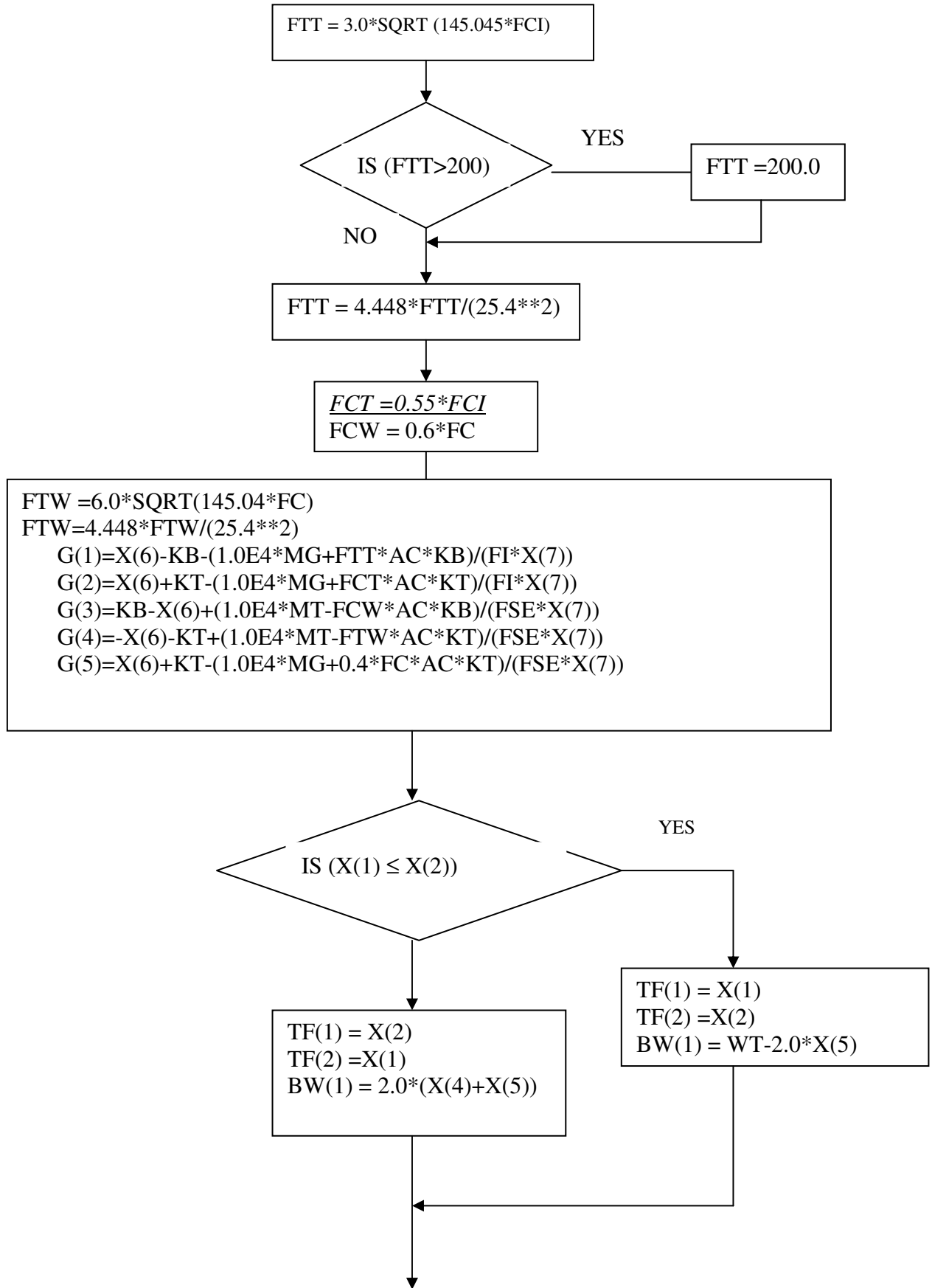

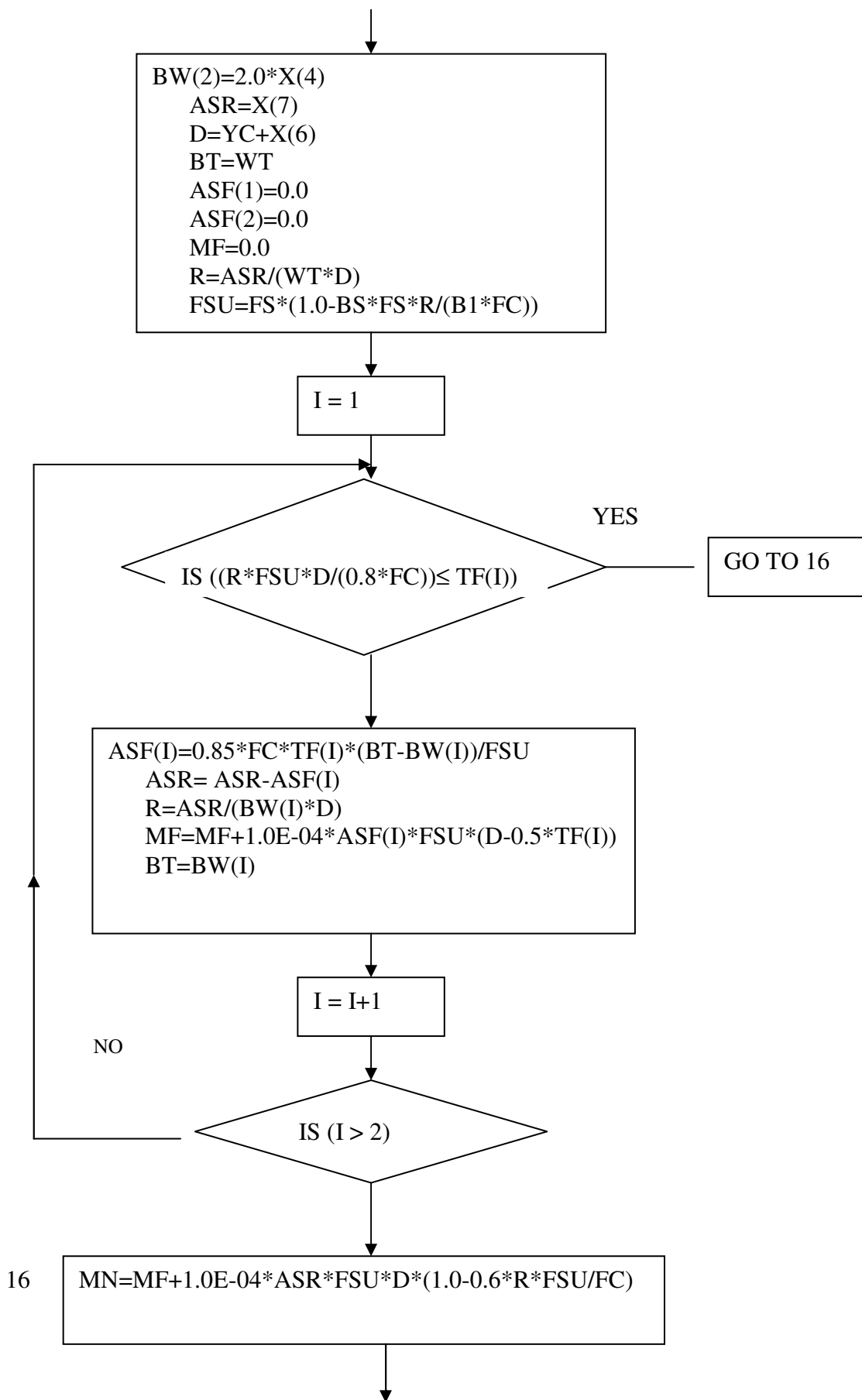

$MULT = 1.3 * (MG + MS + 1.67 * MLL)$
 $G(6) = MULT - 0.9 * MN$
 $G(7) = R * FSU / FC - 0.36 * B1$
 $FR = 190.5 * SQRT(FC / 4.448)$
 $FR = 4.448 * FR / 645.16$
 $MCR = 1.0E-$
 $04 * (FR * KT * AC + FSE * X(7) * KT + FSE * X(6) * X(7)) - MG$
 $G(8) = 1.2 * MCR - 0.9 * MN$

$DF = 1.0E5 * (2812.5 * MG + 3125.0 * MS + 2.0 * 1.19 * (121.61458 * SP * 2 + 1668.0 * SP) - 0.2552083 * FSE * X(6) * X(7)) * SP ** 2 / (EC * IC)$

$G(9) = DF - 1.25 * SP$
 $MGC = 0.5E-06 * UWC * (X(1) * X(5) ** 2 + HFC * WFC ** 2 / 3.0)$
 $MSC = 0.5E-04 * WSS * X(5) ** 2 + 0.01 * WR * X(5)$
 $XX = 0.01 * X(5) - 0.7048$
 $EX = 0.8 * XX + 1.143$

$MLLC = 1.3 * 71.168 * XX / EX$
 $MULTC = 1.3 * (MGC + MSC + 1.67 * MLLC)$
 $RB = 0.85 * B1 * FC * (0.003 / (0.003 + FY / ES)) / FY$
 $RMAX = 0.75 * RB$
 $V = 1.0E3 * RMAX * FY * (1.0 - 0.6 * RMAX * FY / FC)$
 $D1 = 0.01 * X(1) - 0.05$
 $G(10) = MULTC - V * D1 ** 2$

$G(11) = X(1) + HFC - 70.0$
 $G(12) = 20.0 - X(1)$
 $G(13) = (WT - 2.0 * (X(4) + X(5) + wff)) / 30.0 - X(2)$
 $G(14) = (WT - 2.0 * (X(4) + X(5) + wff)) / 30.0 - X(3)$

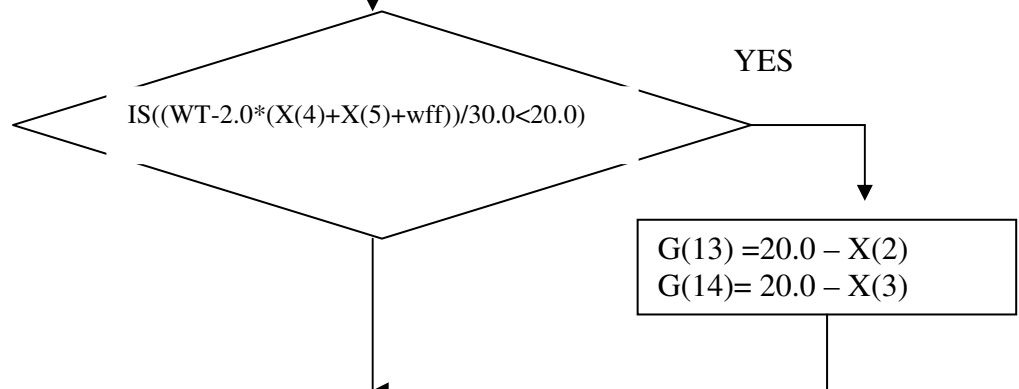

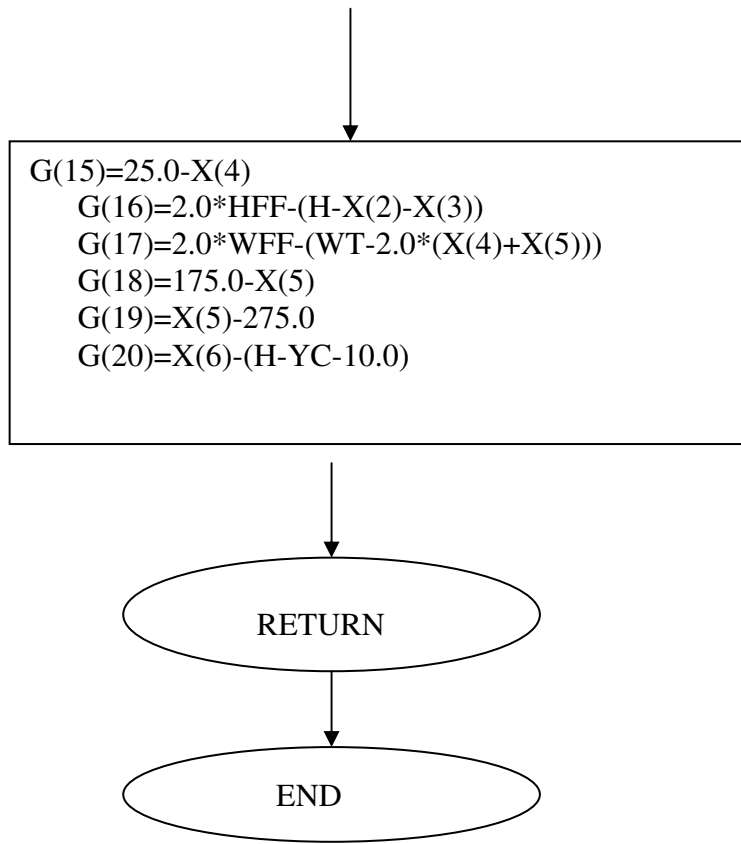

SUBROUTINE GRACON (X,L,GRDG) FLOW CHART

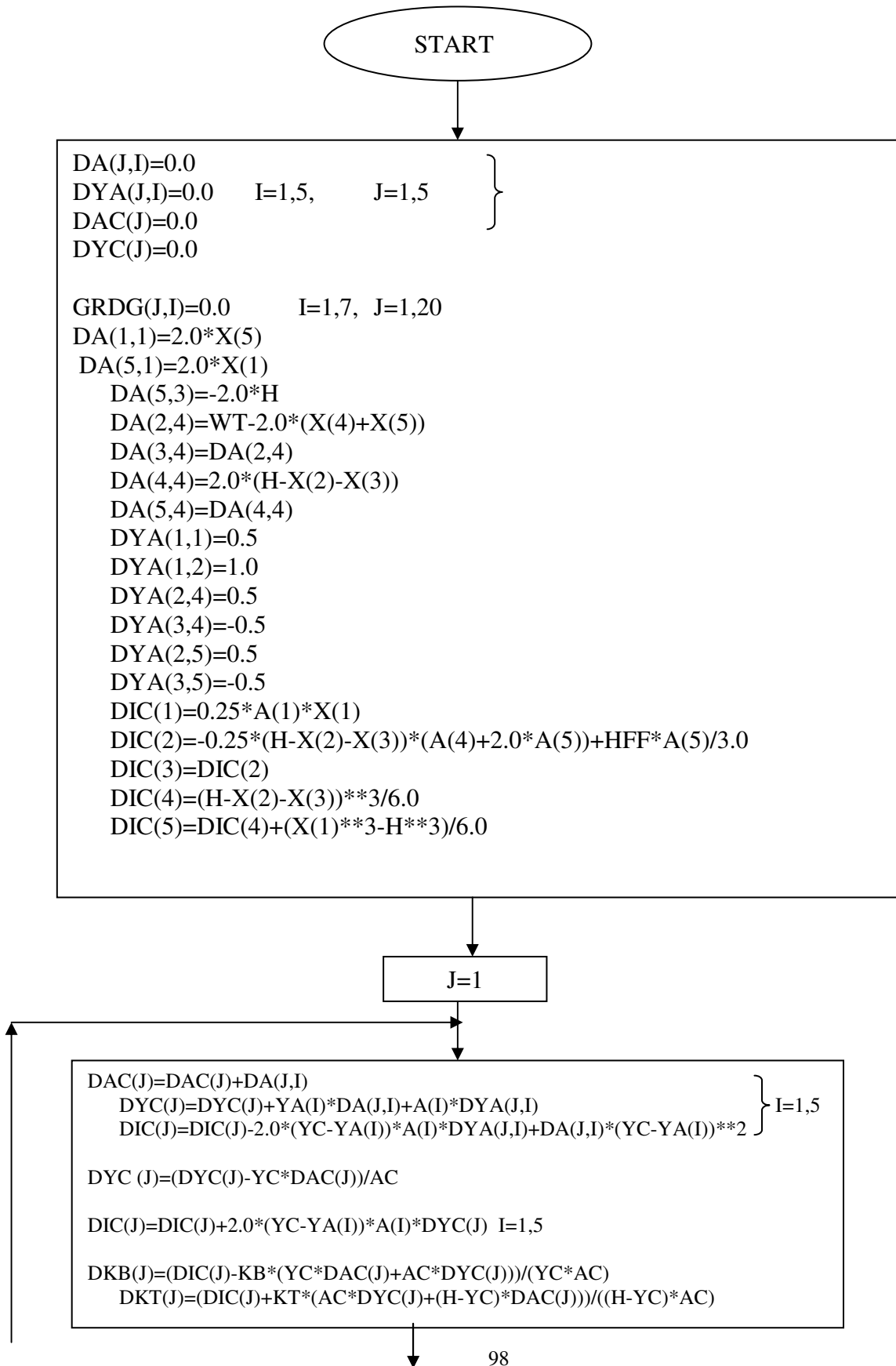

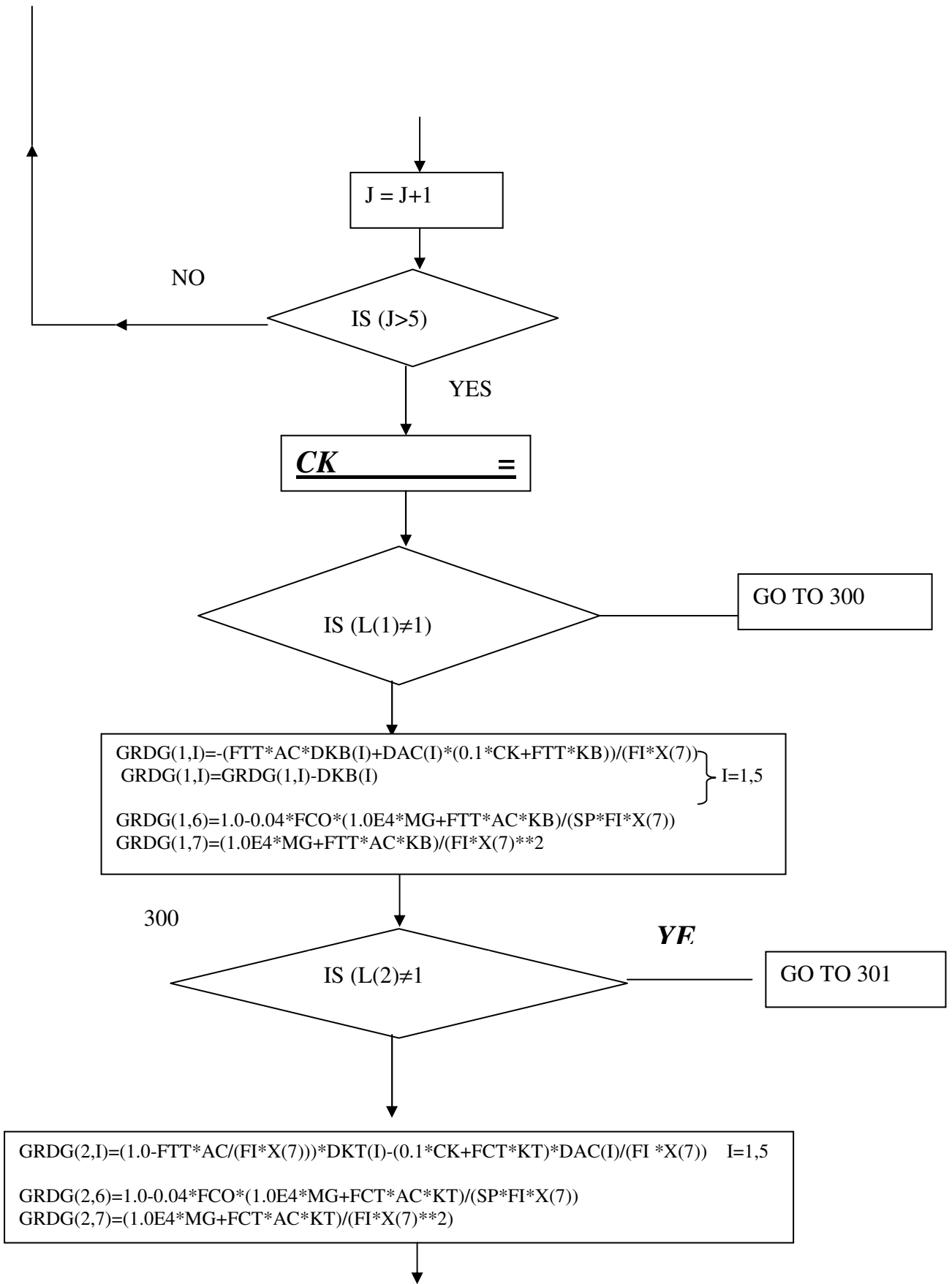

304

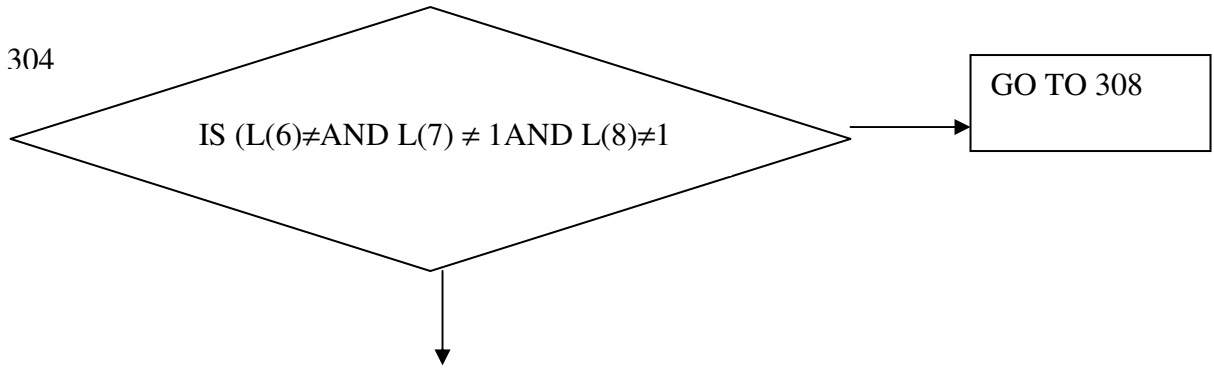

```
DTF(J,I)=0.0
DBW(J,I)=0.0
DASF(J,I)=0.0 } I=1,2 J=1,7
DBT(J)=0.0
DASR(J)=0.0
DMN(J)=0.0

DASR(7)=1.0
ASR=X(7)
BT=WT
R=ASR/(WT*D)
FSU=FS*(1.0-BS*FS*R/(B1*FC))

DD(I)=DYC(I)
DR(I)=-1.0*R*DD(I)/D
DFSU(I)=-1.0*BS*DR(I)*FS**2/(FC*B1) } I=1,5

DD(6)=1.0
DD(7)=0.0
DR(6)=-1.0*R/D
DR(7)=1.0/(WT*D)
DFSU(6)=-1.0*BS*DR(6)*FS**2/(B1*FC)
DFSU(7)=-1.0*BS*DR(7)*FS**2/(B1*FC)
```

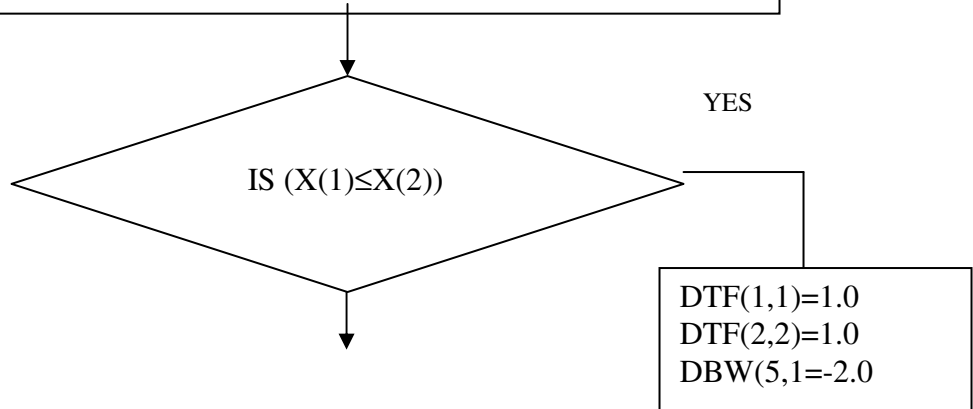

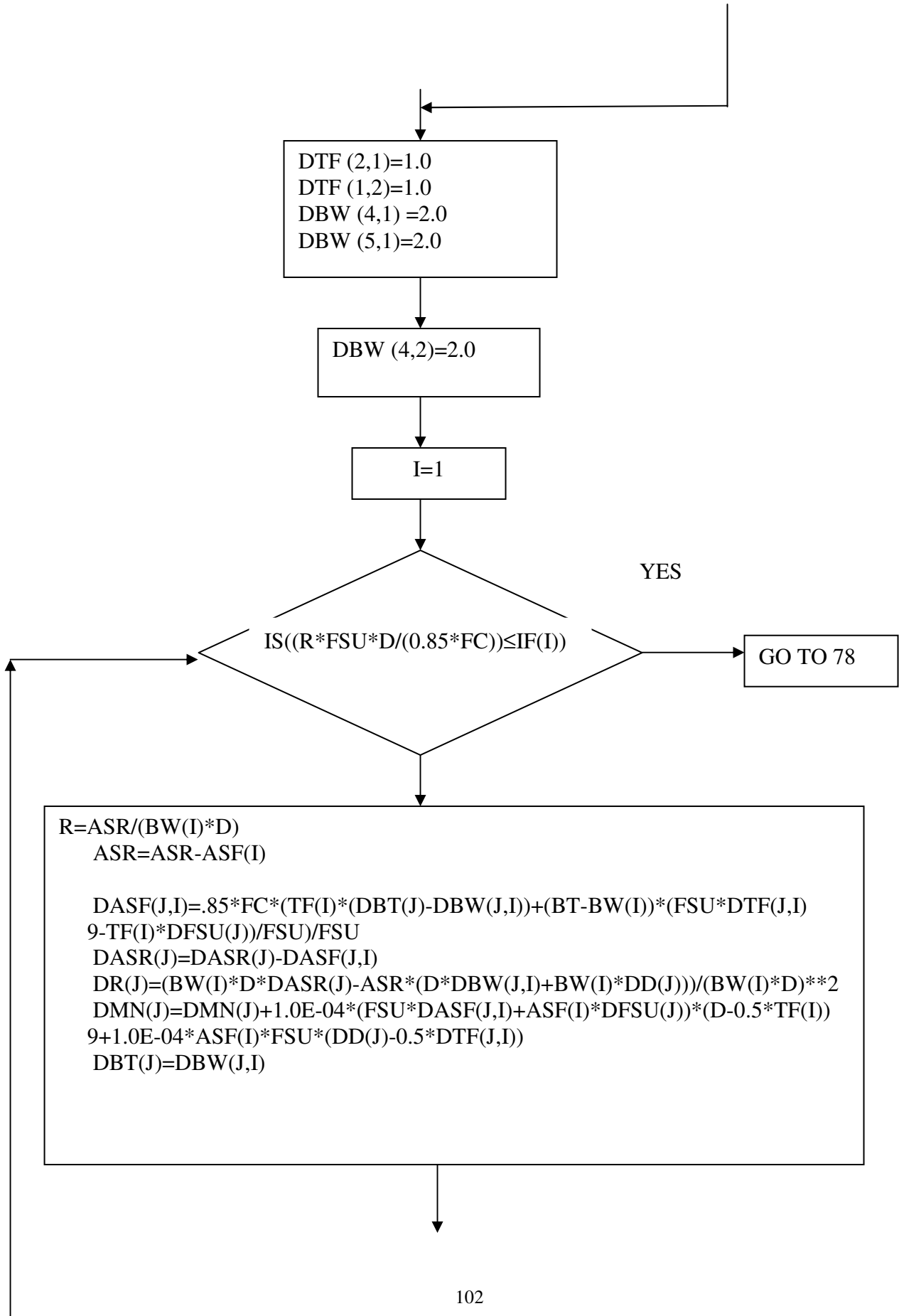

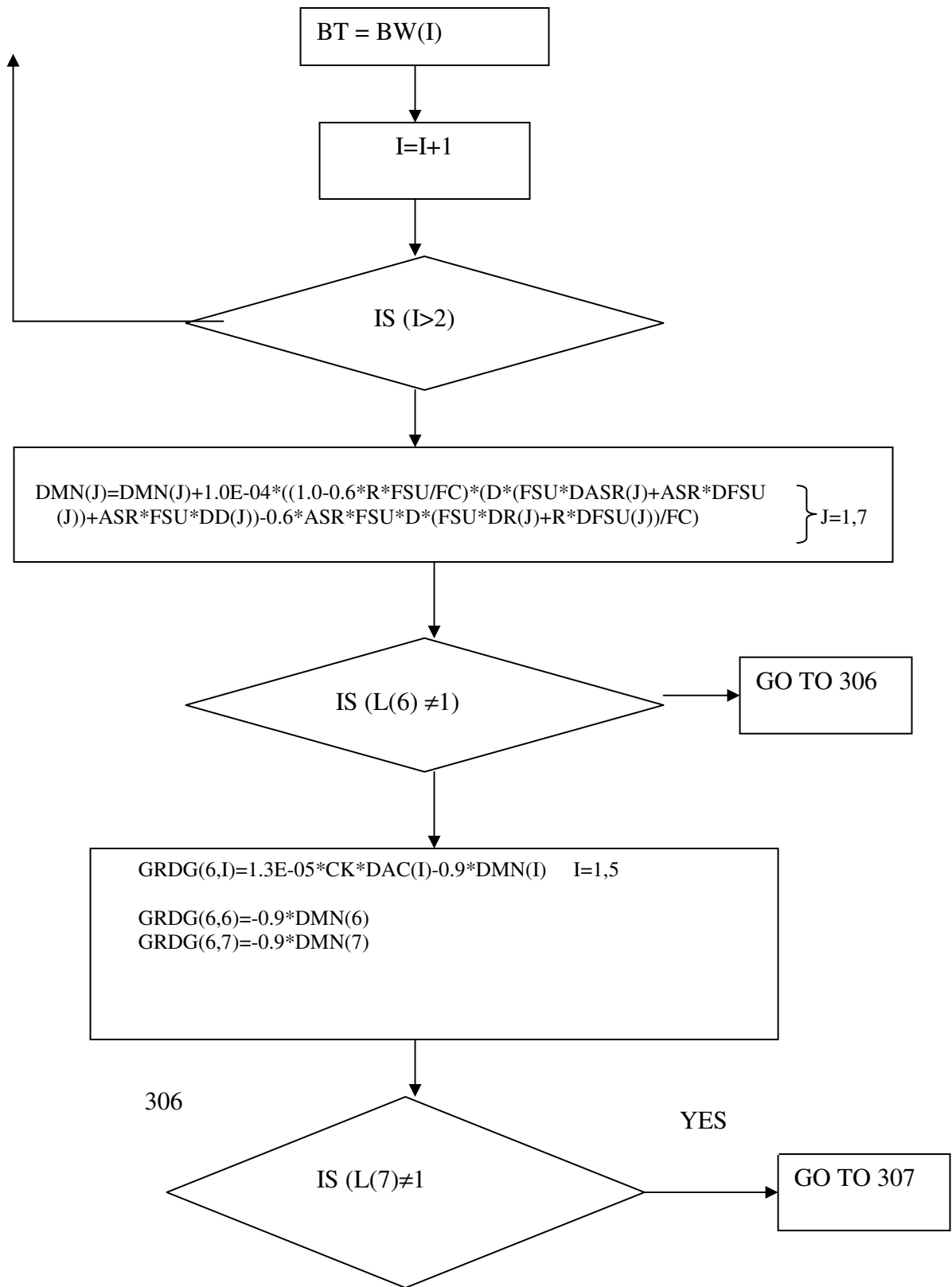

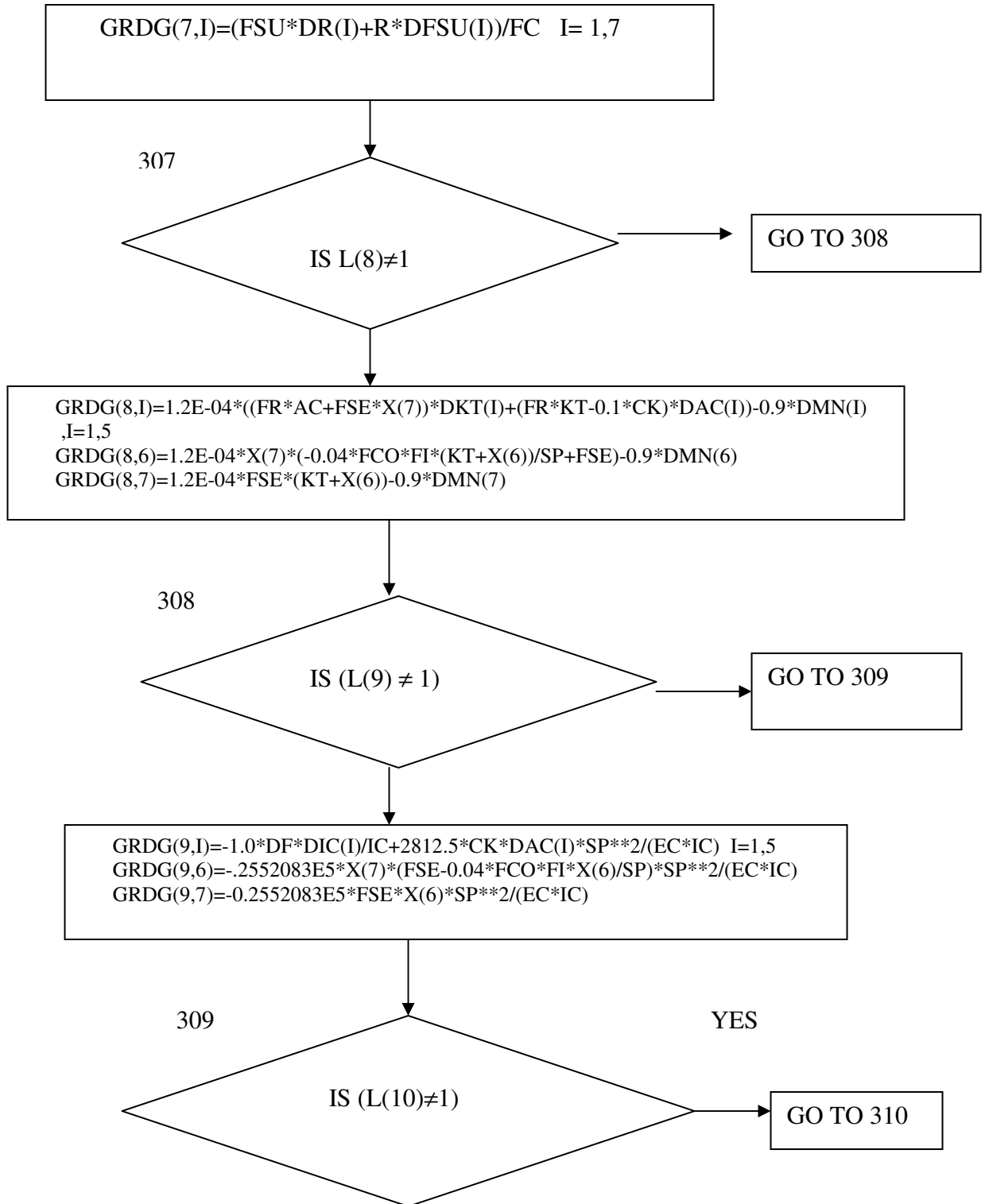

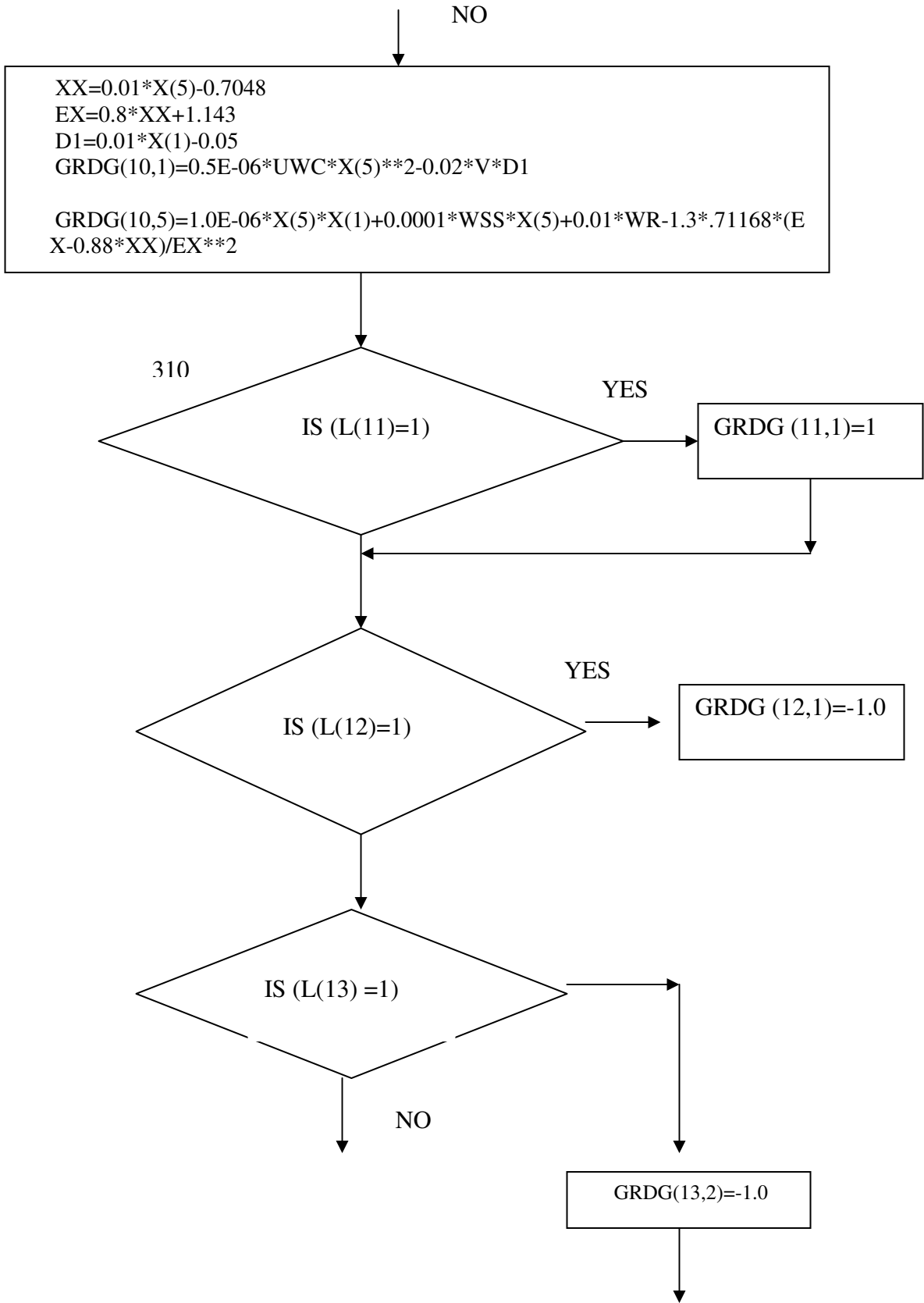

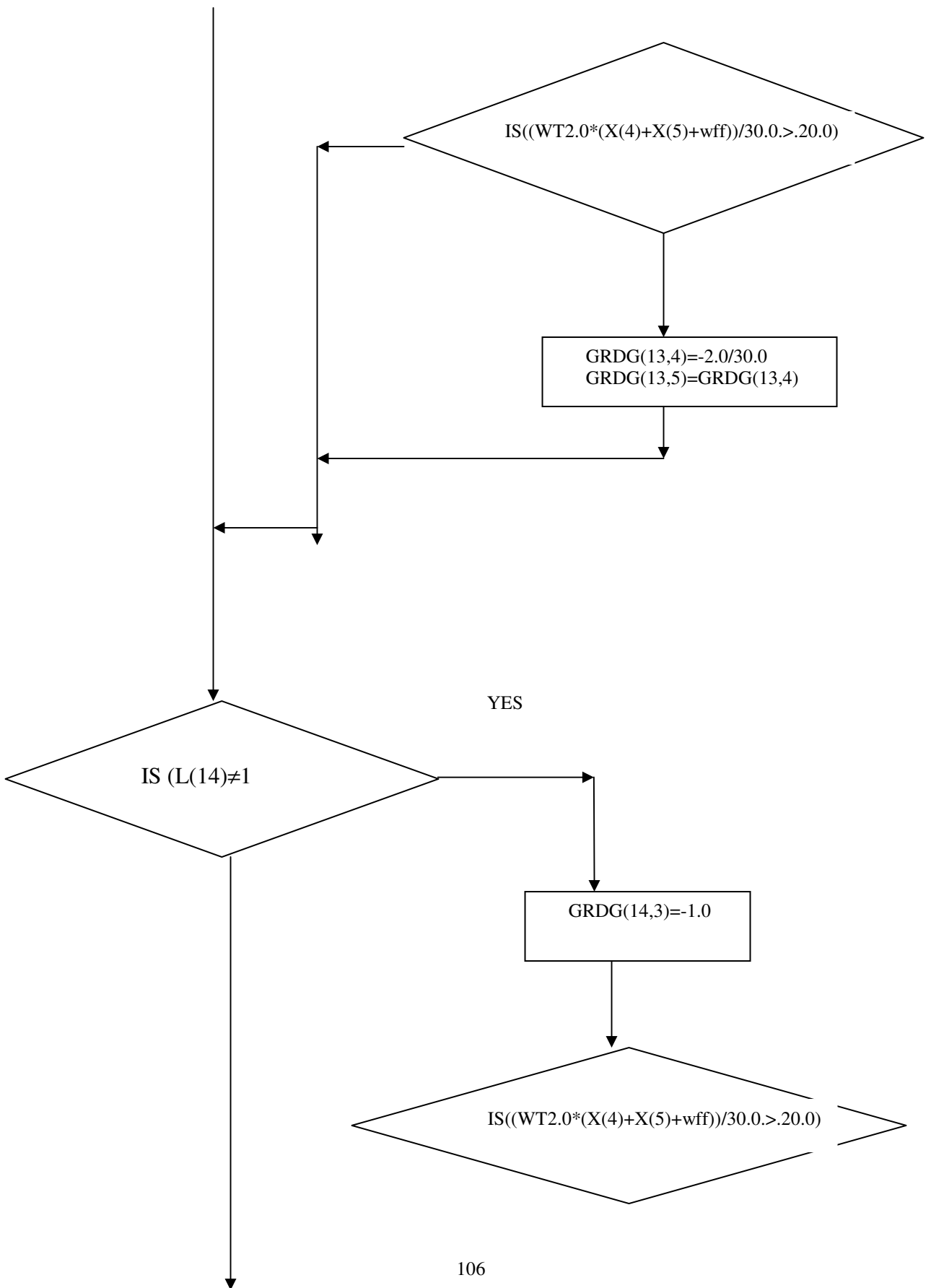

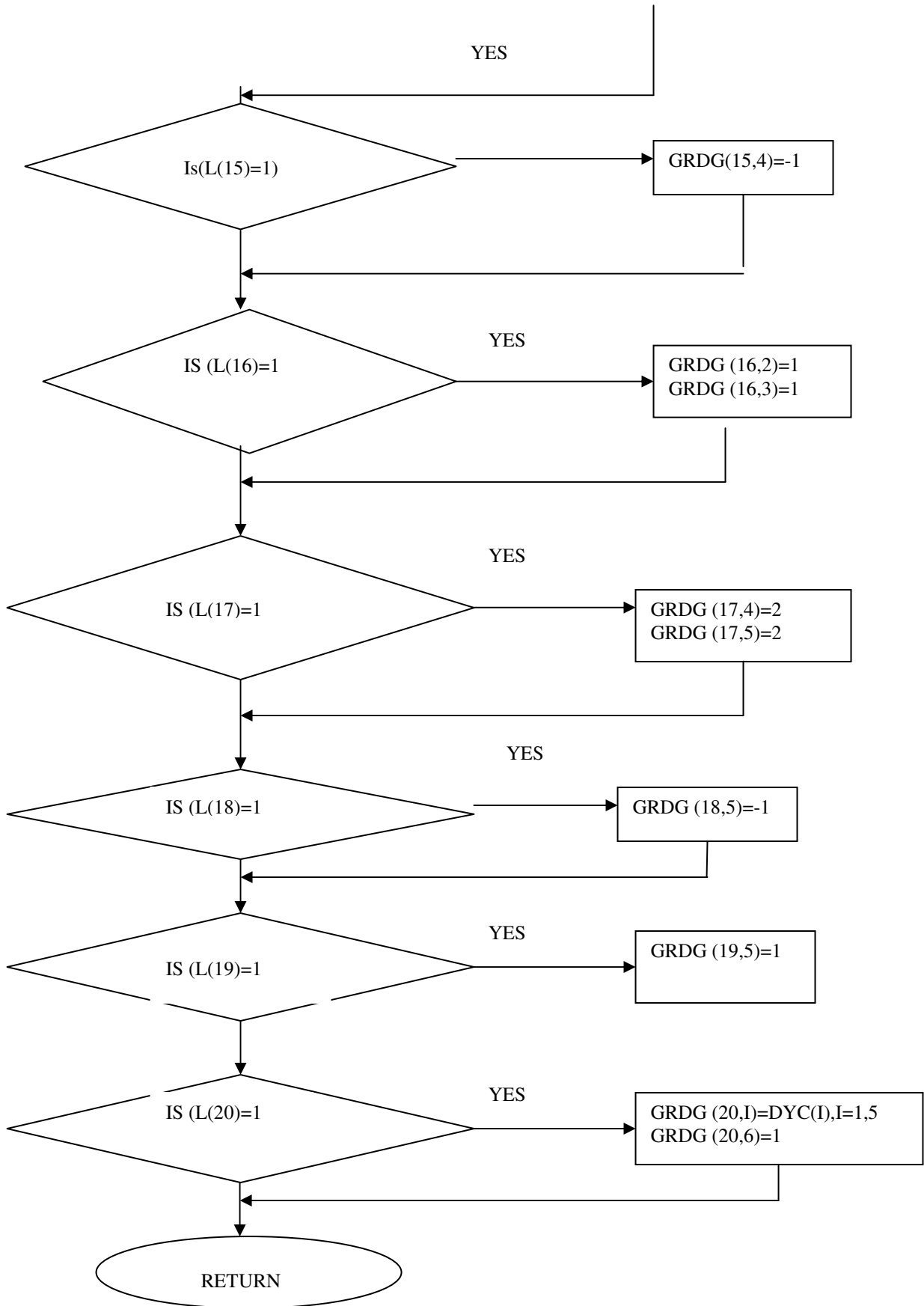

SUB ROUTINE LINPRO FLOW CHART

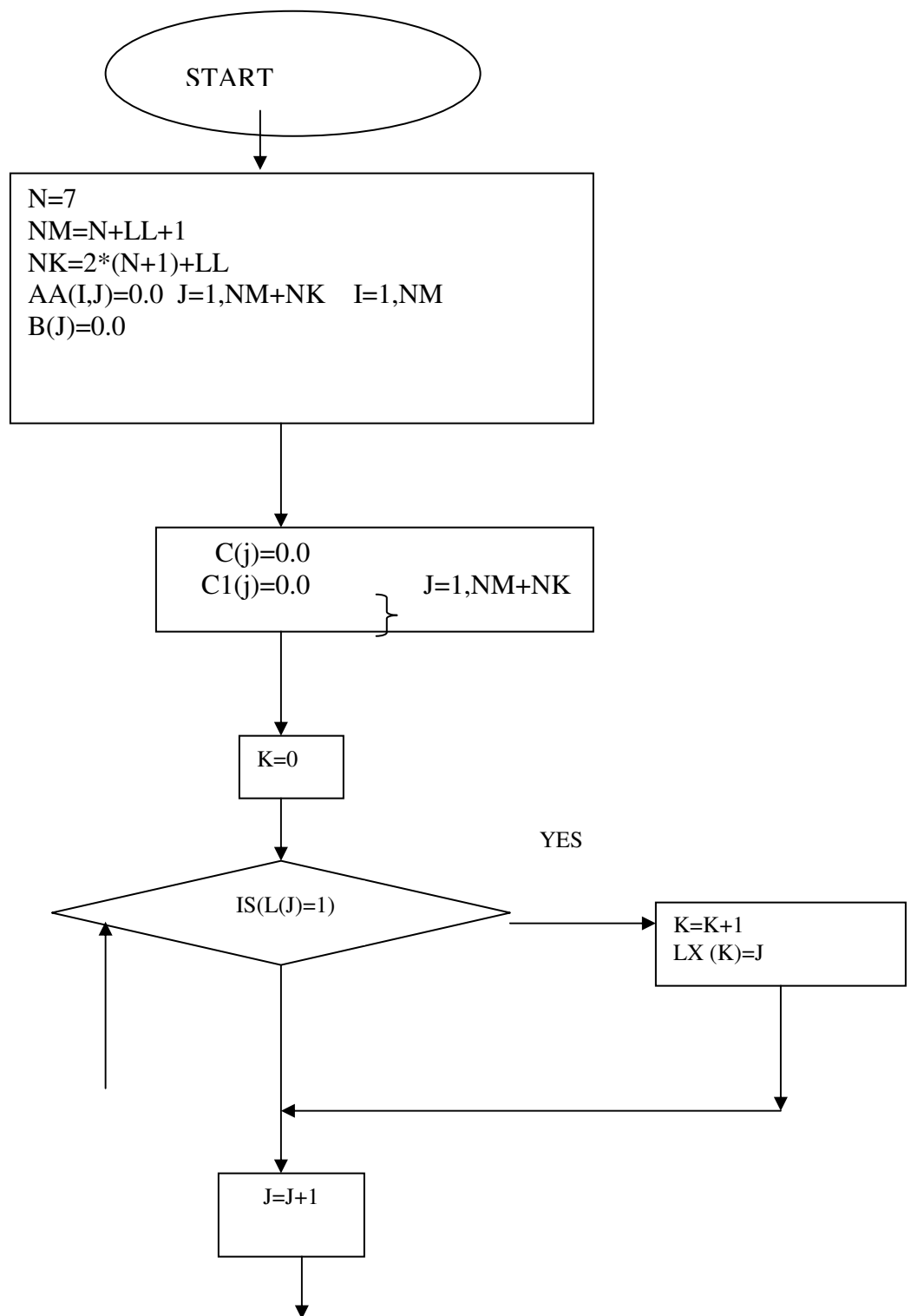

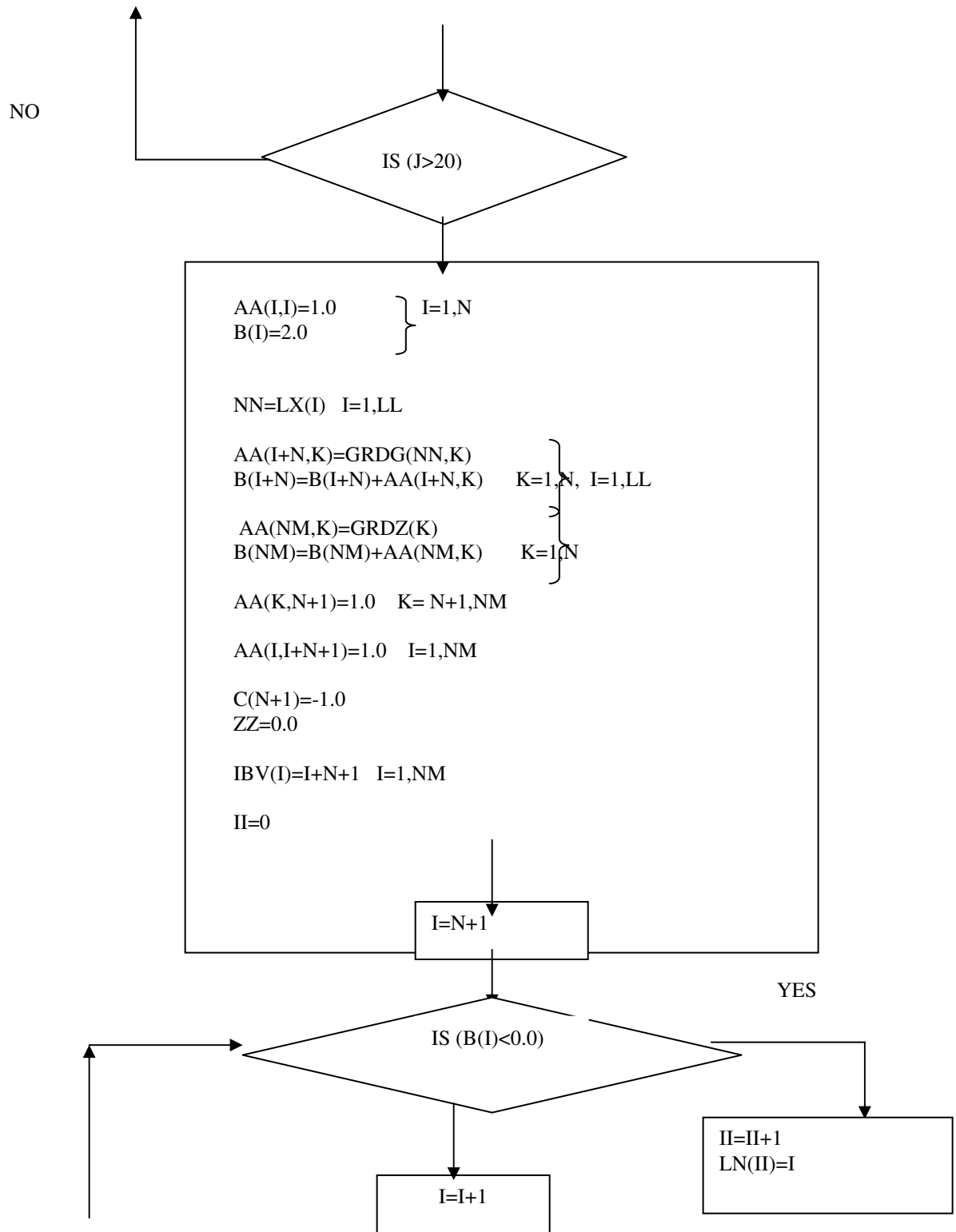

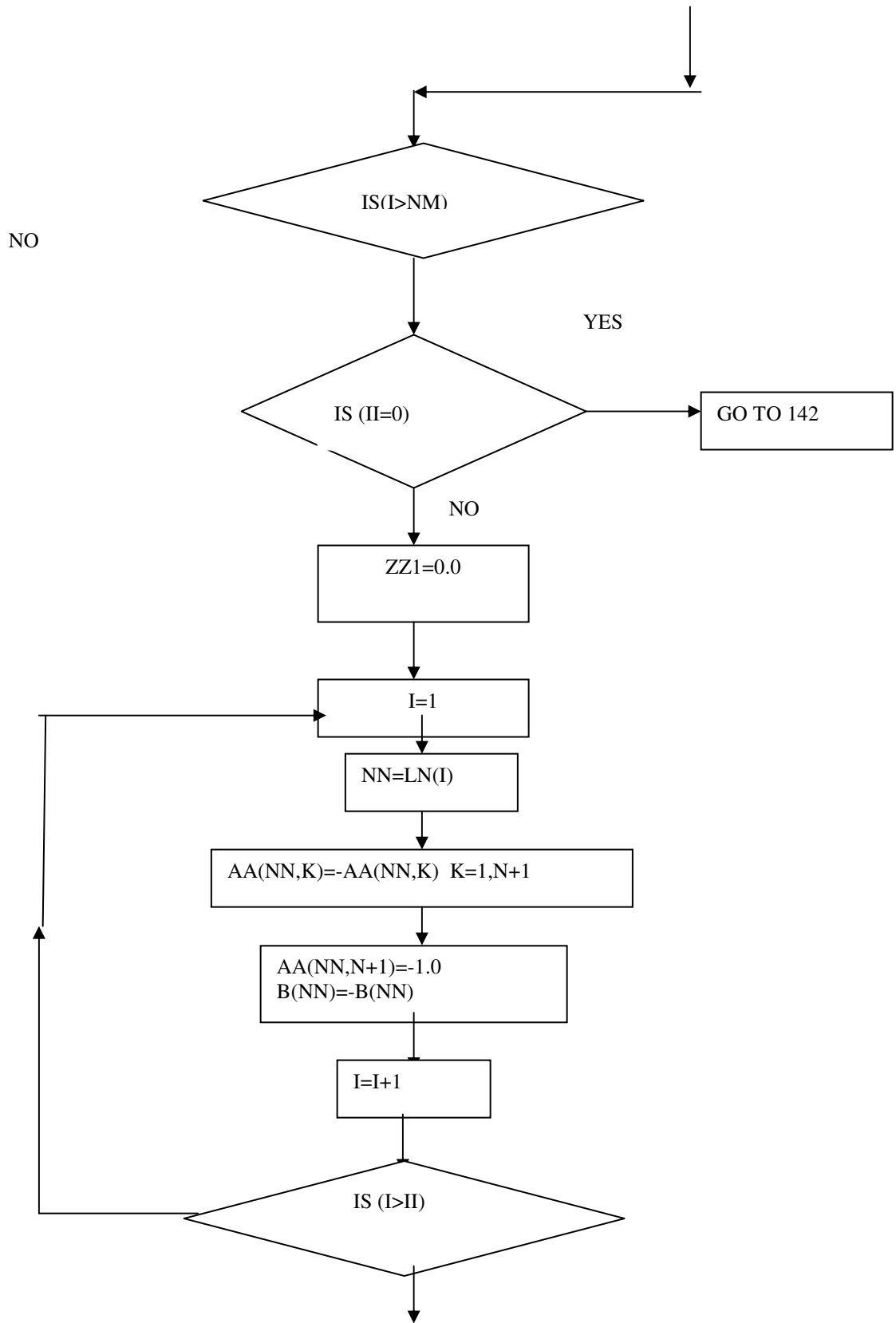

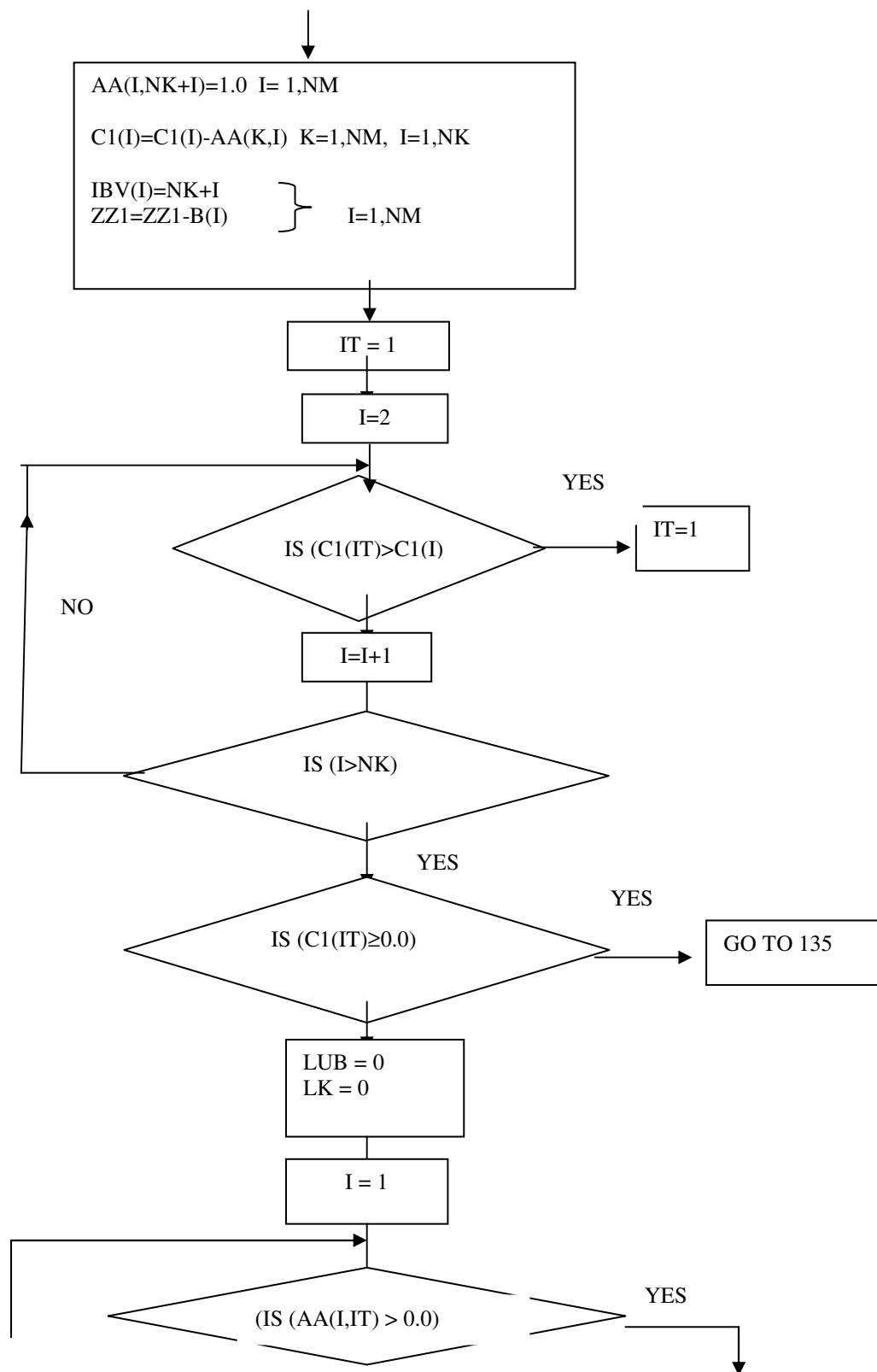

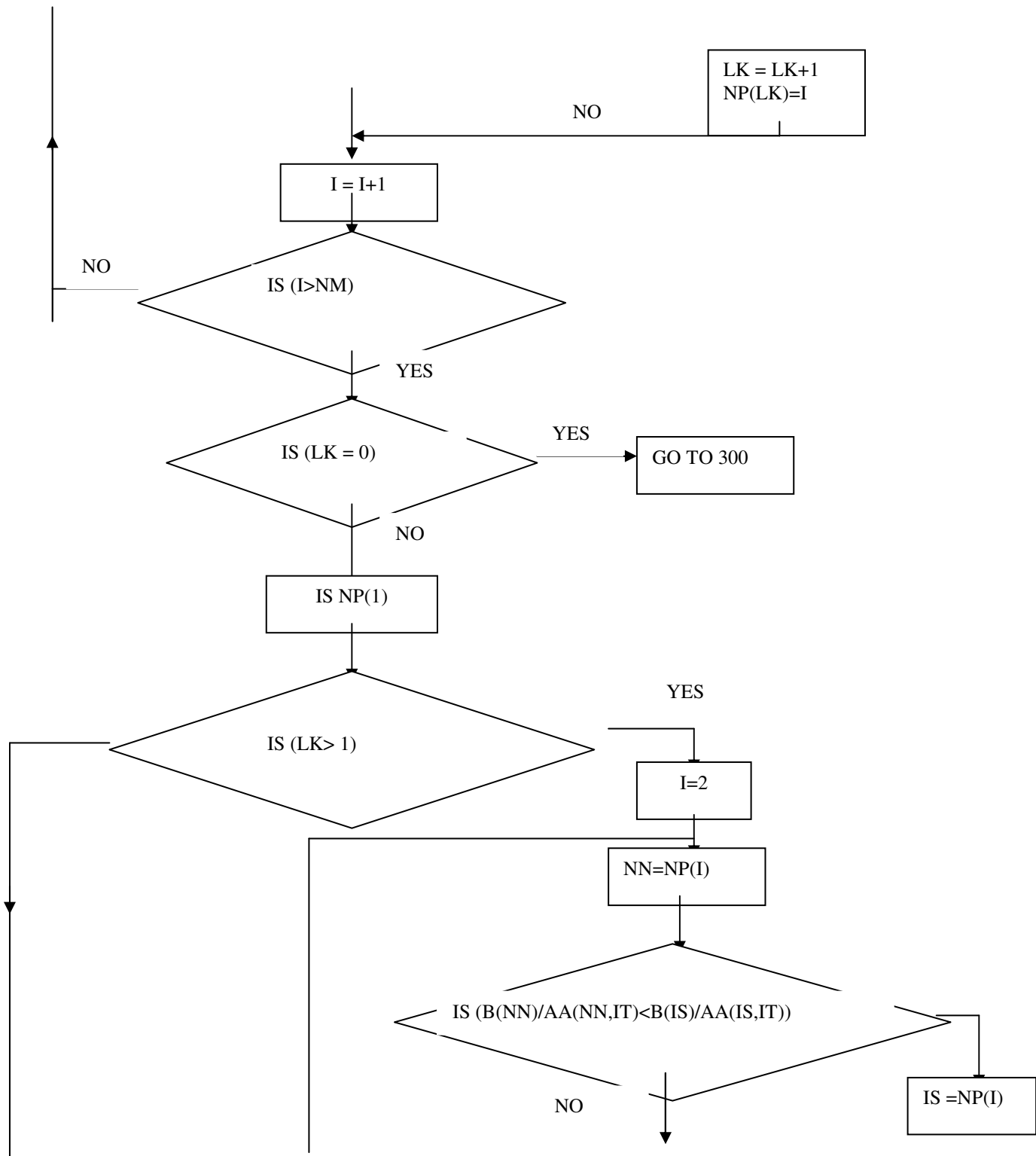

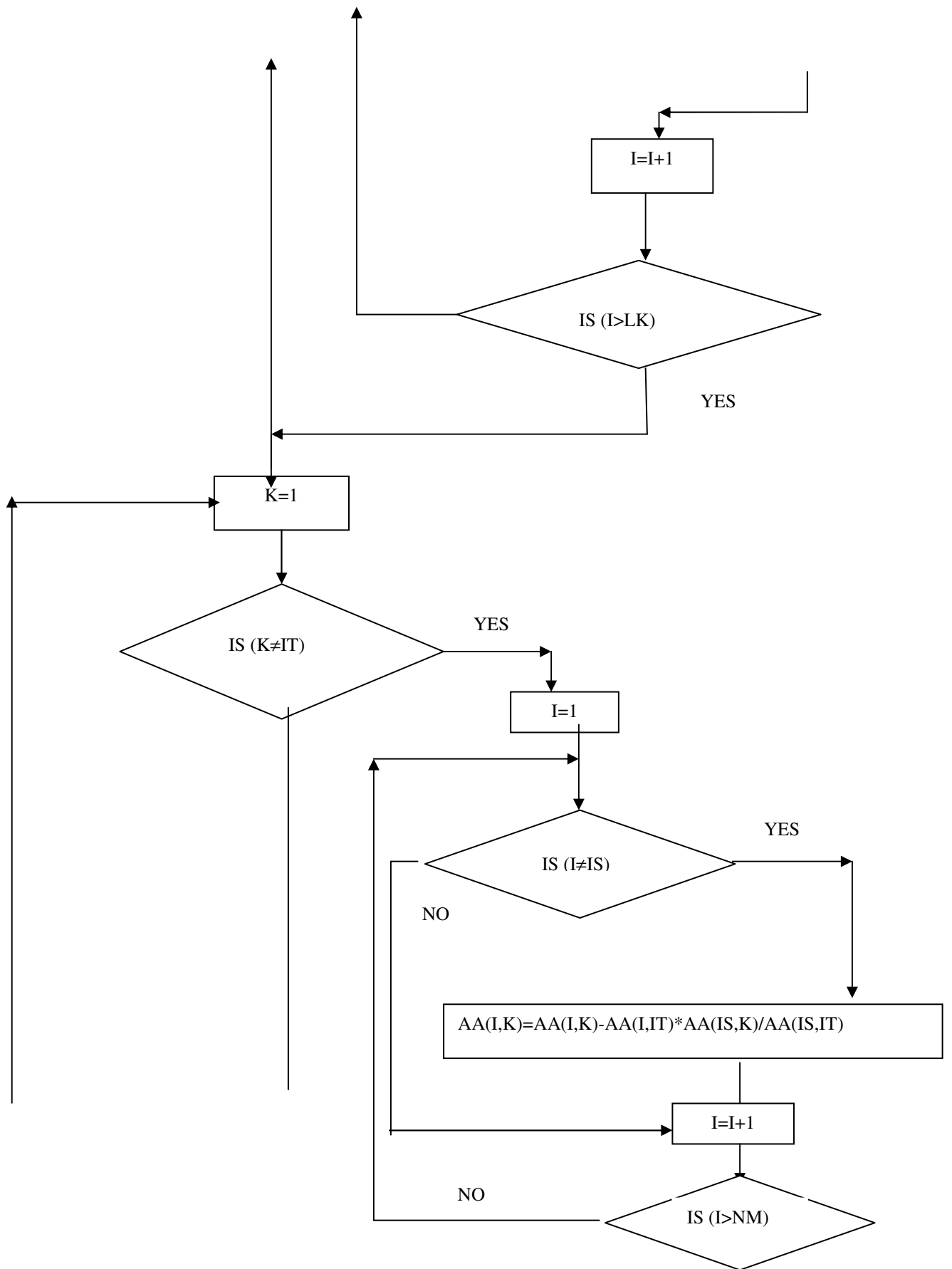

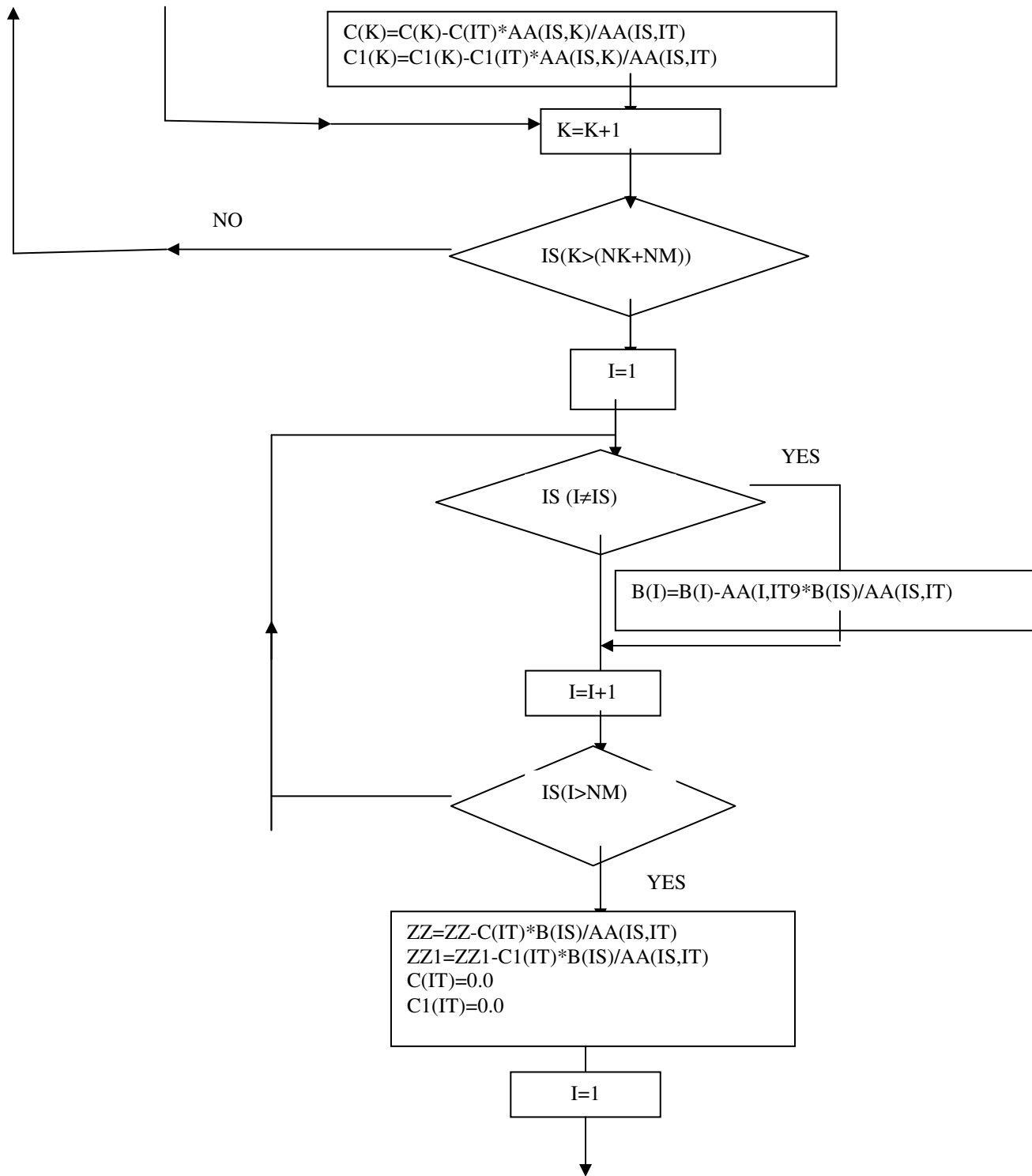

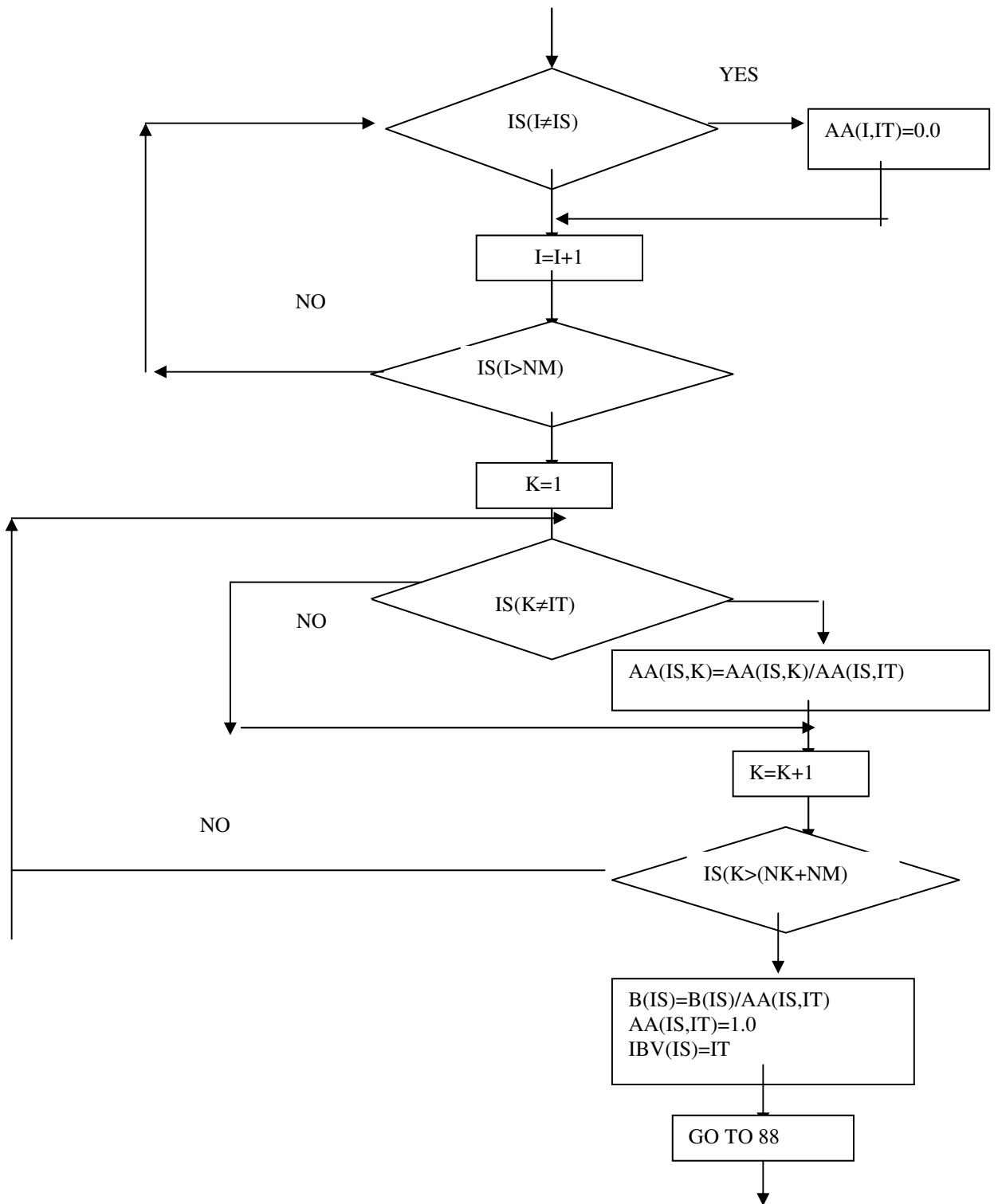

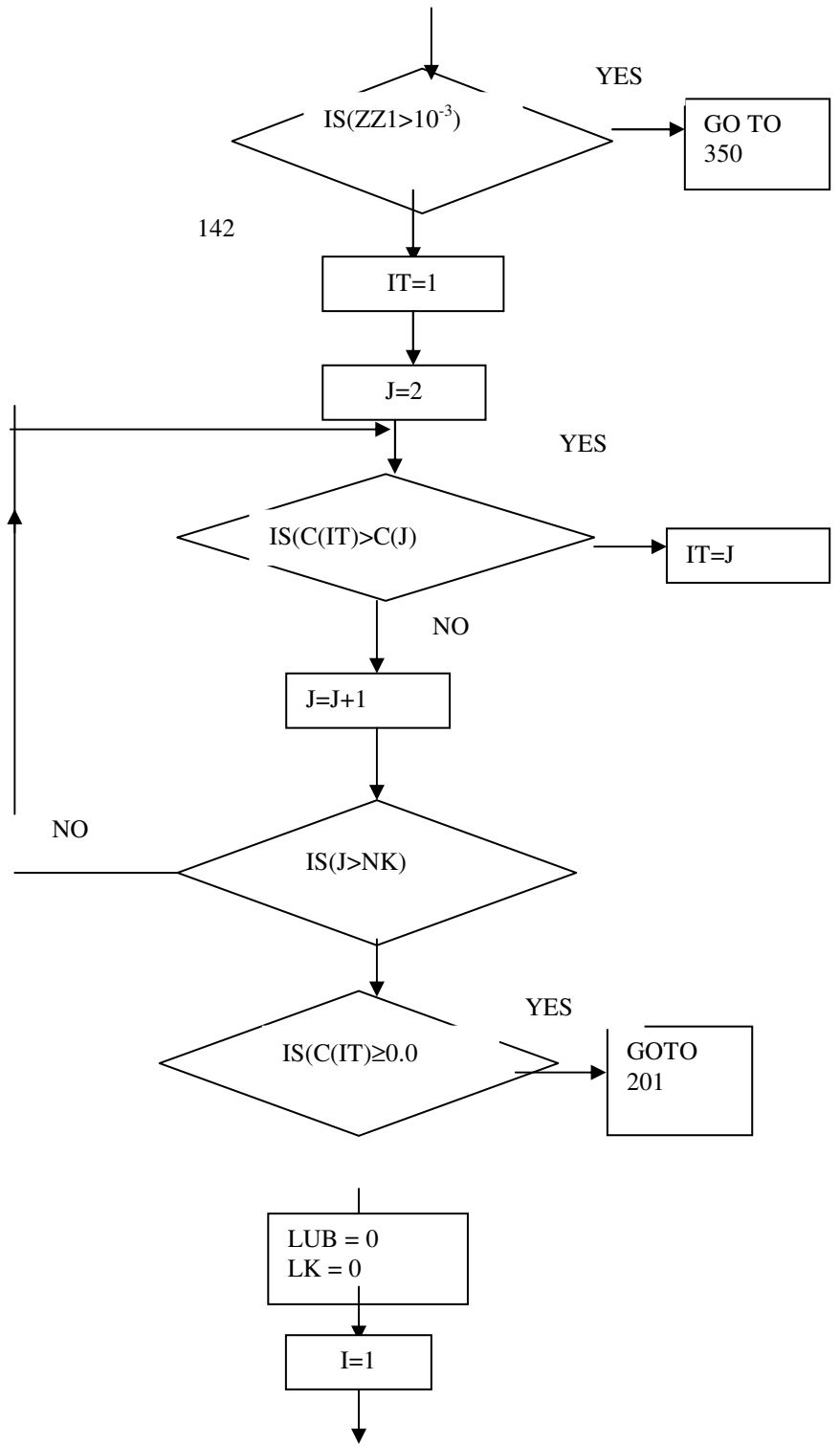

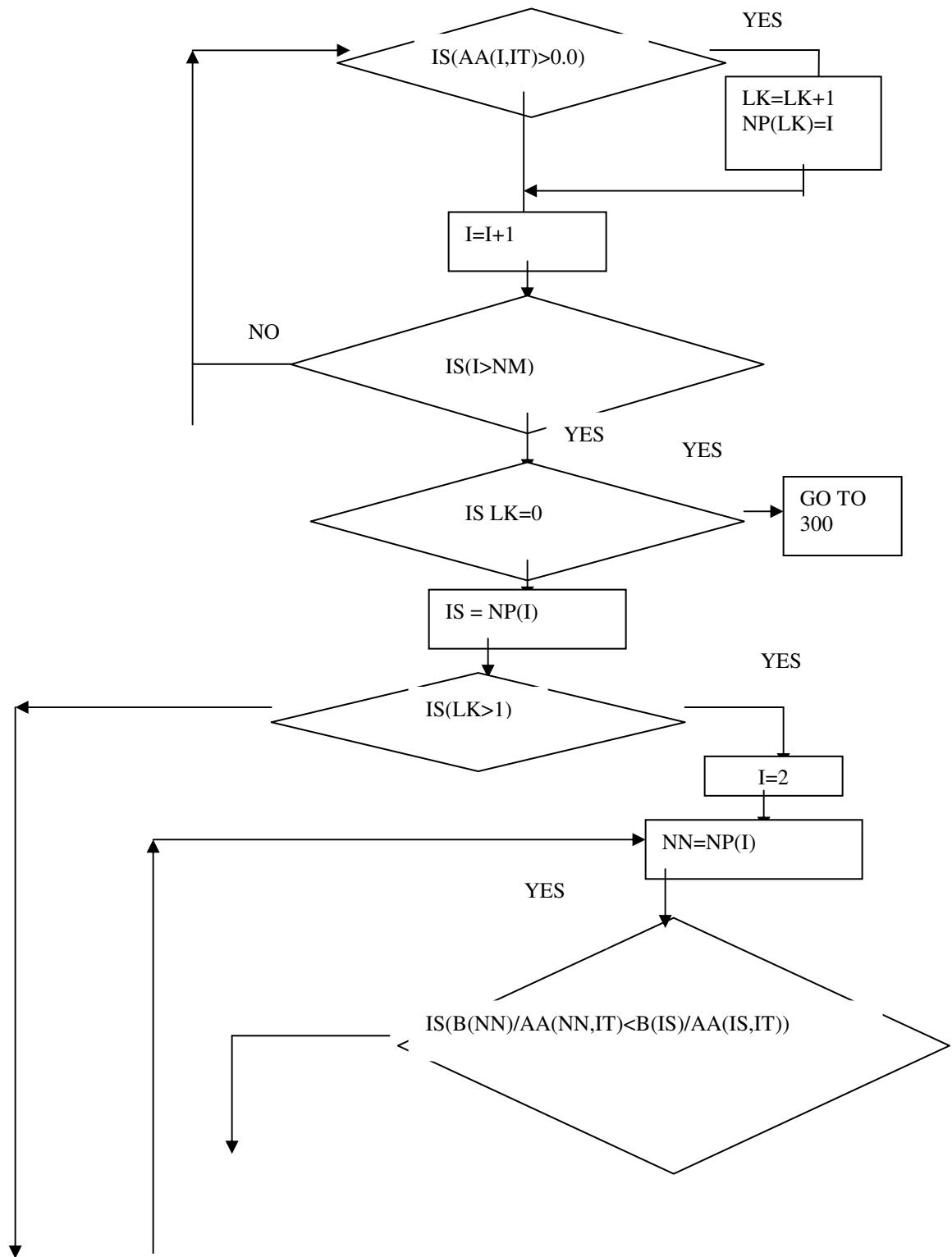

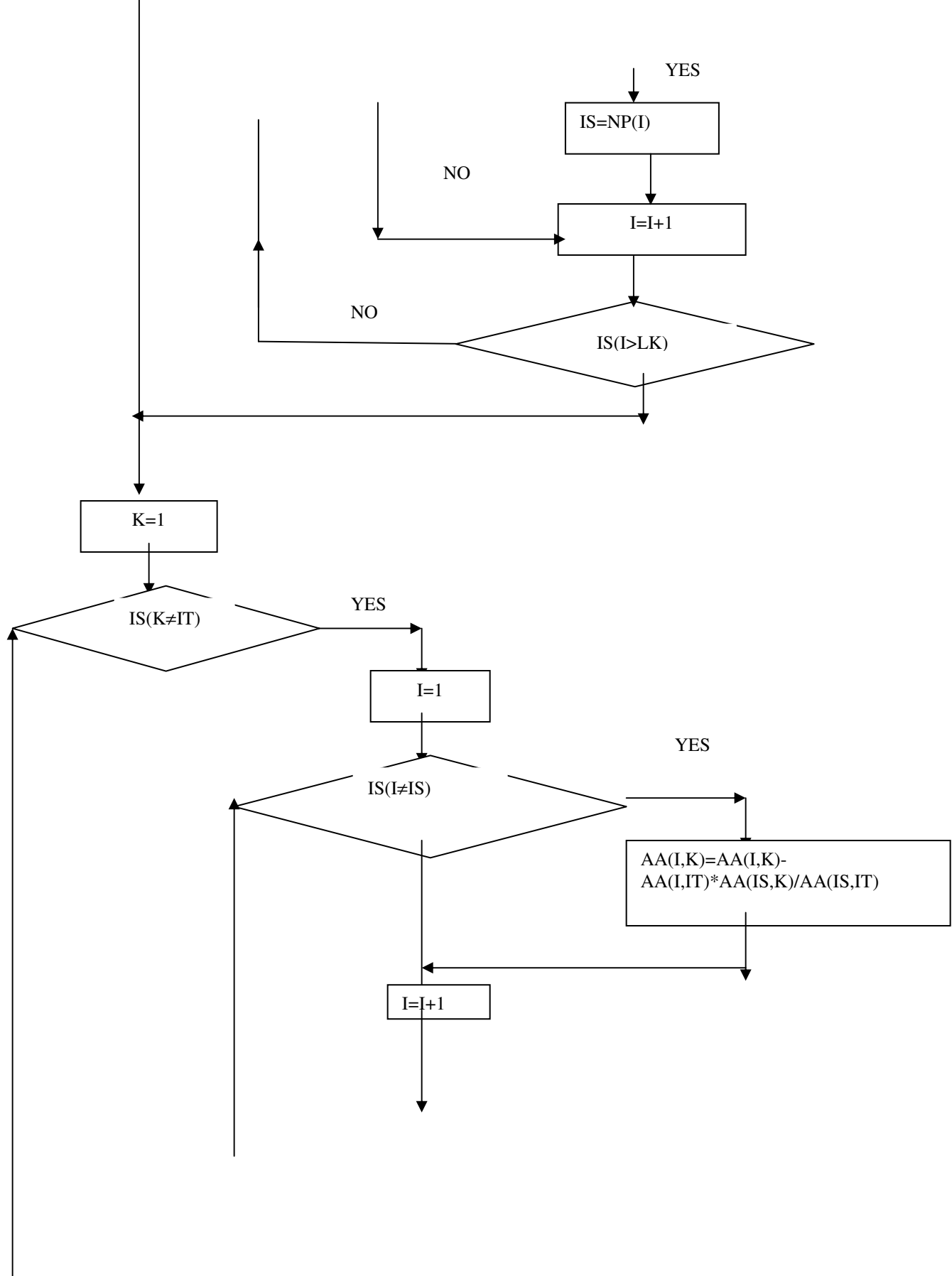

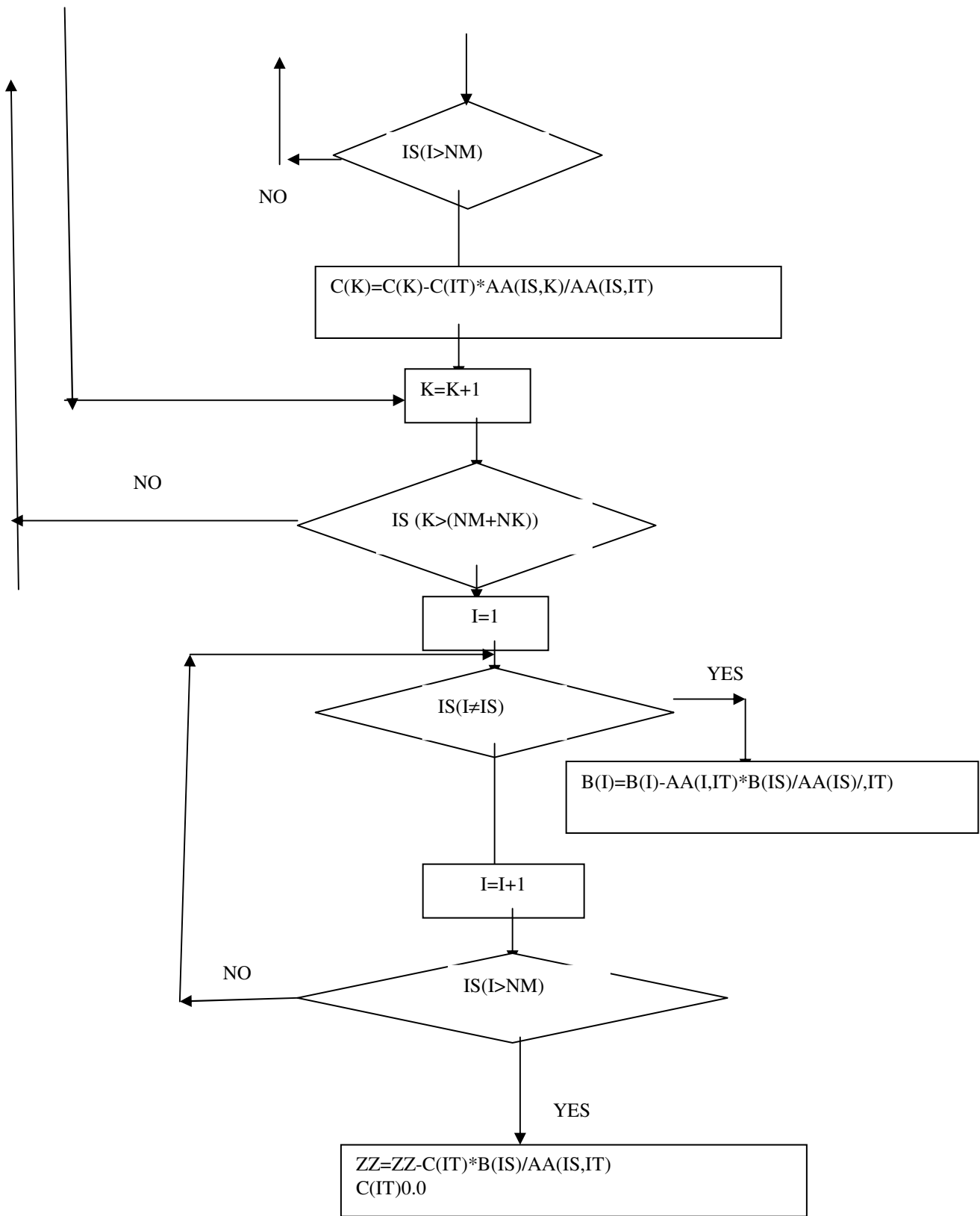

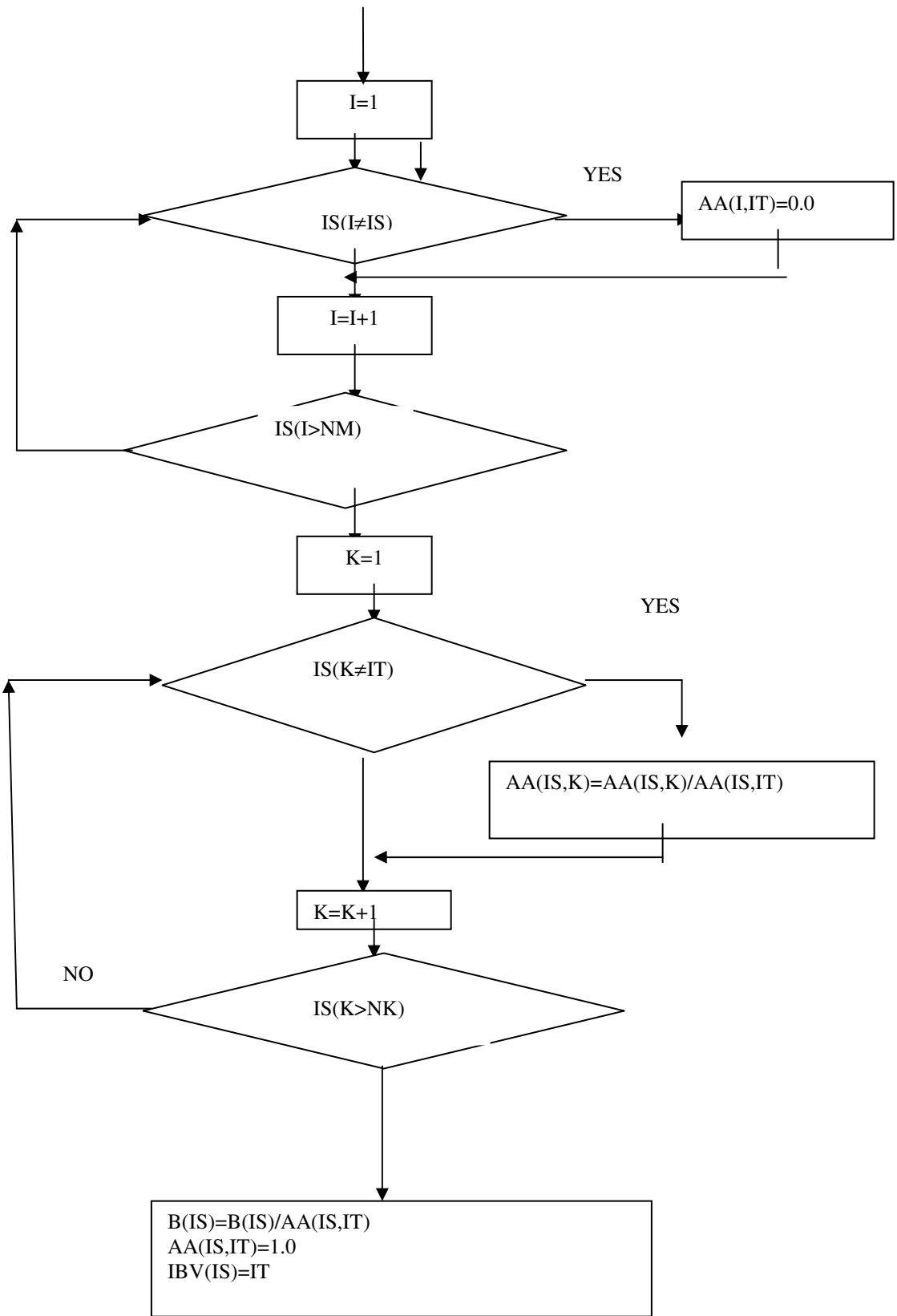

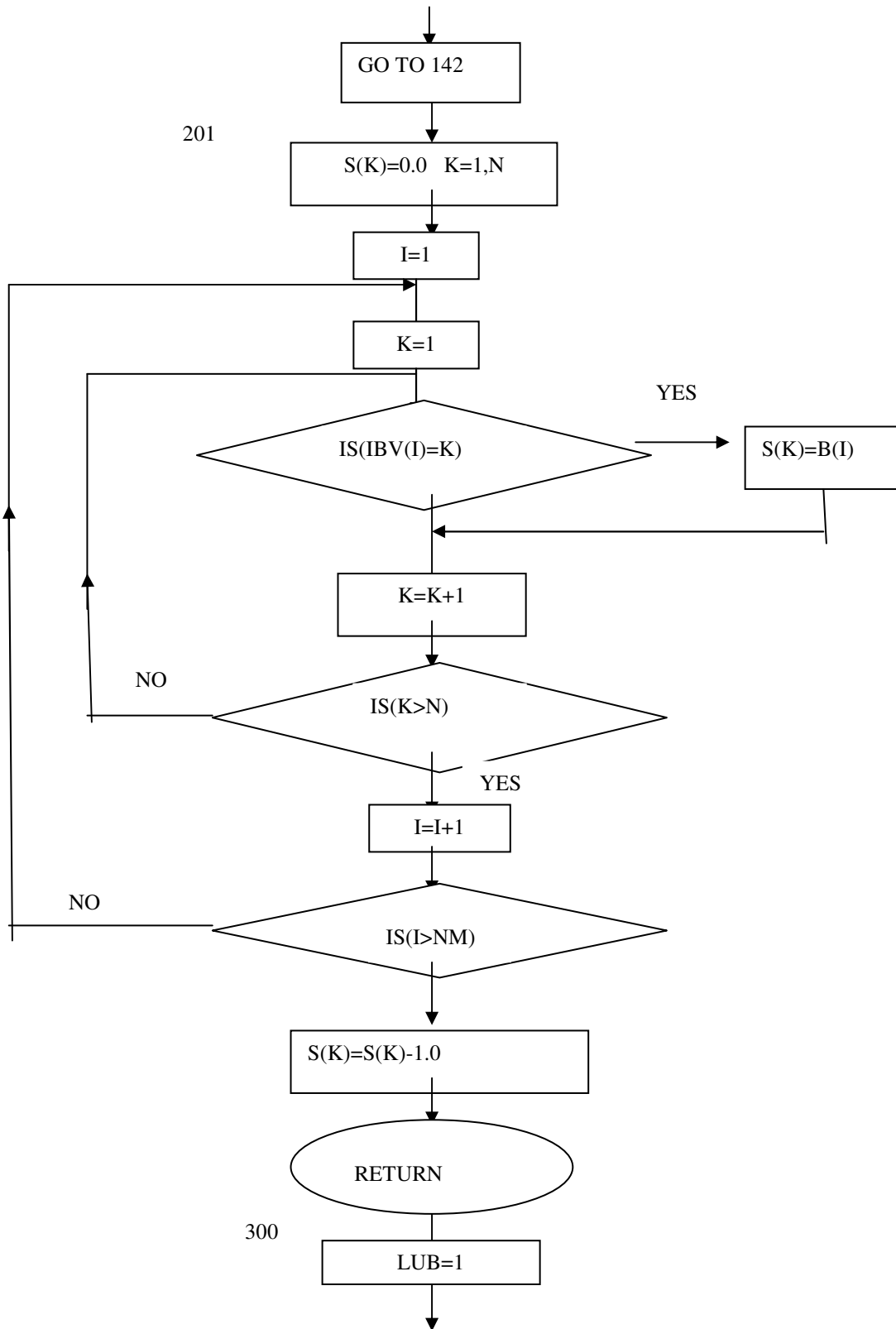

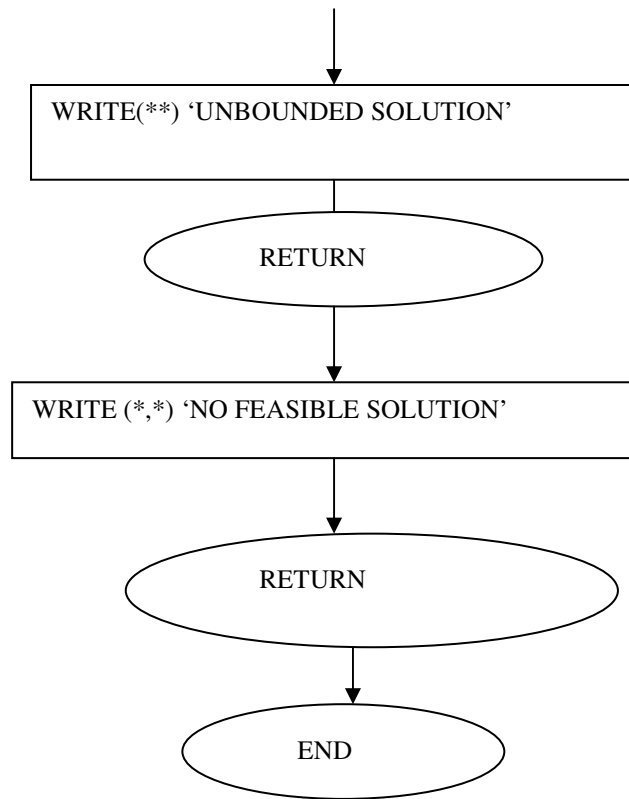

SOURCE CODE

```

    IMPLICIT REAL (M)
    REAL IC, IA, KT, KB
    DIMENSION X1(7), X0(7), XOPT(7)
    DIMENSION A(5), YA(5), TF(2), BW(2), ASF(2), IA(5)
    DIMENSION DA(5,5), DYA(5,5), DAC(5), DYC(5), DIC(5), DKB(5), DKT(5)
    DIMENSION DD(7), DTF(7,2), DBW(7,2), DBT(7), DASF(7,2)
    DIMENSION DASR(7), DMN(7), DR(7), DFSU(7)
    DIMENSION AA(15,31), B(15), C(31), C1(31), IBV(15), NBV(23)
    DIMENSION LN(8), LX(7), NP(15)
    DIMENSION L(20), GRDG(20,7), GRDZ(7), S(7), G(20), EG(20)
    COMMON /BLK1/WFC,HFC,WFF,HFF,WT,H
    COMMON /BLK2/A,YA,AC,YC,IC,KT,KB
    COMMON /BLK3/WSS,WR,MG,MT,SP
    COMMON /BLK4/FS,FI,FSE,BS,UWC,FC,EC,B1
    COMMON /BLK5/TF,BW,D,ASF,FR,DF,V,ASR,R
    COMMON /BLK6/FCI,FY,ES,WC,MLL,SGS,MSC,MLLC,MULTC,FJ
    COMMON /BLK7/FTT,FCT,FCW,FTW,FCO,FSU,BT,D1,XX,EX
    COMMON /BLK8/WS,MS,MF,MN,MULT,MCR,IA,RB,RMAX,WG
    COMMON /BLK9/DA,DYA,DAC,DYC,DIC,DKB,DKT,CK
    COMMON /BLK10/DD,DTF,DBW,DBT,DASF,DASR,DMN,DR,DFSU
    COMMON /BLK11/AA,B,C,C1,IBV,NBV,LN,LX,NP
    COMMON /BLK12/ZZ1,NM,NK,NN,II,IT,LK,IS,LUB,N
    COMMON /BLK13/AREA
    COMMON //I,J,K
    N=7
C   DATA ENTERED AS INPUT
    DATA E1,E2,E3,EG/2*1.0E-05,1.0E-8,5*0.01,0.001,0.01,0.001,12*0.1/
    DATA WT,H,SP,WFC,HFC/1030.0,200.0,40.0,100.0,20.0/
    DATA WFF,HFF,UWC,FCI,FC/100.0,20.0,24.0,27.5578,34.472/
    DATA EC,B1,FS,BS,FY,ES/27788.0,0.8,1860.0,0.28,300.0,200000.0/
    DATA WC,FCO,WSS,WR,MLL/0.00066,0.2,0.431,11.52,674.902/
    OPEN(UNIT=5,FILE='INPUT.FOR',STATUS='OLD')
    OPEN(UNIT=8,FILE='fkG.for',FORM='FORMATTED',status='old')
    READ(5,*)(X0(I),I=1,7)
    WRITE(8,5)
    5  FORMAT(15X,'DATA USED IN OPTIMAZATION'//5X,'CROSS SECTIONAL DATA')
    WRITE(8,10)WT,H,SP
    10  FORMAT(10X,'TOTAL WIDTH OF THE BRIDGE=',F10.3,'CM'/10X,'TOTALDEPTH
    9  OF THE GIRDER=',F9.3,'CM'/10X,'SPAN =',F5.2,'M')
    WRITE(8,15)WFC,HFC,WFF,HFF
    15  FORMAT(10X,'FILLET AT CANTILEVER'/15X,'FILLET WIDTH=',F9.3,'CM'/15
    9  X,'FILLET DEPTH =',F9.3,'CM'/10X,'FILLET IN THE BOX'/15X,'FILLET
    9  WIDTH=',F9.3,'CM'/15X,'FILLET DEPTH=',F9.3,'CM')
    WRITE(8,20)UWC,FCI,FC,EC,B1
    20  FORMAT(5X,'MATERIAL DATA'/10X,'CONCRETE'/15X,'UNIT WEIGHT=',F6.2,'
    9  KN/M3'/15X,'FCI=',F8.3,'MPA'/15X,'FC=',F8.3,'MPA'/15X,'EC=',F10.2,
    9  'MPA'/15X,'B1=',F6.3)
    WRITE(8,25)FS,BS,WC,FCO
    25  FORMAT(10X,'TENDON'/15X,'FS=',F8.3,'MPA'/15X,'          ',F6.3/
    9  10X,'FRICTIONAL LOSS COEFFIENT'/15X,'LENGTH COEFFIENT=',F7.4/15X,'
    9  FRICTIONAL COEFFIENT=',F7.4)
    WRITE(8,30)WSS,WR,MLL
    30  FORMAT(5X,'LOAD'/10X,'SUPERIMPOSED LOADS'/15X,'ASPHALT 1 INCH THIC
    9  H=',F8.4,'KN/M2'/15X,'RAILING=',F8.4,'KN/M'/10X,'LIVE LOAD MOMENT=
    9  ',F10.4,'TON METER')

    ITER=1
    Z0=COST(X0)
    CALL  CONST(X0,G)
    DO 66 J=1,20
    IF(G(J) .GT. 0.0)GO TO 150

```

```

66 CONTINUE
   WRITE(8,33)
33  FORMAT(5X,'X1',8X,'X2',8X,'X3',8X,'X4',7X,'X5',7X,'X6',7X,'X7',7X,
9'Z')
   WRITE(8,35)(X0(I),I=1,7),Z0
35  FORMAT(3X,F7.2,6(2X,F7.3),F12.4)
C   SOURTING OUT ACTIVE CONSTRAINT
120 LL=0
   DO 40 J=1,20
   GG=ABS(G(J))
   IF(GG .LE. EG(J))THEN
   L(J)=1
   LL=LL+1
   ELSE
   L(J)=0
   ENDIF
40  CONTINUE
   IF(LL .NE. 0)THEN
C   SEARCHING DIRECTION VECTORS
   CALL GRAOBJ(X0,GRDZ)
   CALL GRACON(X0,L,GRDG)
   CALL LINPRO(LL,L,GRDG,GRDZ,S,ZZ)
   IF(ZZ1.GT.1.0E-3)GO TO 200
   IF(LUB.EQ. 1)GO TO 300
   IF(ZZ .LE. E1)GO TO 105
   ELSE
   CALL GRAOBJ(X0,GRDZ)
   DO 45 I=1,7
   S(I)=-GRDZ(I)
45  CONTINUE
   ENDIF
C   NORMALIZING DIRECTION VECTOR
   SNR=0.0
   DO 50 I=1,7
   SNR=SNR+S(I)**2
50  CONTINUE
   SNR=SQRT(SNR)
   DO 55 I=1,7
   S(I)=S(I)/ABS(SNR)
55  CONTINUE
   DZ0=0.0
   DO 60 I=1,7
   DZ0=DZ0+S(I)*GRDZ(I)
60  CONTINUE
C   MINIMAZATION ALONG THE SELECTED DIRECTION VECTOR
   E=15.0
125 DO 65 I=1,7
   X1(I)=X0(I)+E*S(I)
65  CONTINUE
   CALL CONST(X1,G)
   DO 70 J=1,20
   IF(G(J) .GT. 0.0)GO TO 110
70  CONTINUE
   Z1=COST(X1)
   IF(Z1 .GT. Z0)GO TO 110
   XNR=0.0
   DO 75 I=1,7
   XNR=XNR+(X1(I)-X0(I))**2
75  CONTINUE
   XNR=ABS(SQRT(XNR))
   ZZZ=ABS(Z1-Z0)
   IF((ZZZ.LE. E2) .AND. (XNR .LE. E3))GO TO 225
   WRITE(8,76)ITER

```

```

76   FORMAT(5X,'ITER=',I3)
      WRITE(8,35)(X1(I),I=1,7),Z1
      DO 85 I=1,7
      X0(I)=X1(I)
85   CONTINUE
      Z0=Z1
      ITER=ITER+1
      IF(ITER .EQ. 100)GO TO 225
      GO TO 120
110  E=.9*E
      GO TO 125
225  DO 90 I=1,7
      XOPT(I)=X1(I)
90   CONTINUE
      ZOPT=Z1
      GO TO 130
200  write(*,*) 'NO FEAS. SOLN'
      GO TO 105
300  write(*,*) 'UNBOUNDED SOLN'
105  DO 95 I=1,7
      XOPT(I)=X0(I)
95   CONTINUE
      ZOPT=Z0
130  WRITE(8,100)ITER
100  FORMAT(5X,'ITER=',I3)
      DO 101 I=1,7
      WRITE(8,102)I,XOPT(I)
102  FORMAT(10X,'XOPT',I2,'=',F10.3)
101  CONTINUE
      WRITE(8,103)ZOPT
103  FORMAT(15X,'ZOPT=',F10.3)
      STOP
150  write(*,*) 'infeasible'
      write(*,*)j,g(j)
      STOP
      END

      FUNCTION COST(X)
      DIMENSION X(7)
      COMMON /BLK1/WFC,HFC,WFF,HFF,WT,H
      COMMON /BLK13/AREA
C    EVALUATION OF OBJECTIVE FUNCTION
      AREA=2.0*X(1)*X(5)+H*(WT-2.0*X(5))+WFC*HFC
      AREA=AREA-(H-X(2)-X(3))*(WT-2.0*(X(5)+X(4)))+2.0*HFF*WFF
      COST=.12*AREA+50.0*X(7)
      RETURN
      END

      SUBROUTINE GRAOBJ(X,GRDZ)
      DIMENSION X(7),GRDZ(7)
      COMMON /BLK1/WFC,HFC,WFF,HFF,WT,H
C    EVALUATION OF THE OBJECTIVE FUNCTION GRADIENT
      GRDZ(1)=2400.0E-04*X(5)
      GRDZ(2)=1200.0E-04*(WT-2.0*(X(5)+X(4)))
      GRDZ(3)=GRDZ(2)
      GRDZ(4)=2400.0E-04*(H-X(2)-X(3))
      GRDZ(5)=2400.0E-04*(X(1)-X(2)-X(3))
      GRDZ(6)=0.0
      GRDZ(7)=50.0
      RETURN
      END

```

```

SUBROUTINE CONST (X,G)
IMPLICIT REAL (M)
REAL IC, IA, KT, KB
DIMENSION X(7), G(20)
DIMENSION A(5), YA(5), TF(2), BW(2), ASF(2), IA(5)
COMMON /BLK1/WFC, HFC, WFF, HFF, WT, H
COMMON /BLK2/A, YA, AC, YC, IC, KT, KB
COMMON /BLK3/WSS, WR, MG, MT, SP
COMMON /BLK4/FS, FI, FSE, BS, UWC, FC, EC, B1
COMMON /BLK5/TF, BW, D, ASF, FR, DF, V, ASR, R
COMMON /BLK6/FCI, FY, ES, WC, MLL, MGS, MSC, MLLC, MULTC, FJ
COMMON /BLK7/FTT, FCT, FCW, FTW, FCO, FSU, BT, D1, XX, EX
COMMON /BLK8/WS, MS, MF, MN, MULT, MCR, IA, RB, RMAX, WG
COMMON //I, J, K
C COMPUTATION OF CROSS SECTIONAL PROPERTY
A(1)=2.0*X(1)*X(5)
A(2)= HFC*WFC
A(3)=H*(WT-2.0*X(5))
A(4)=-1.0*(H-X(2)-X(3))*(WT-2.0*(X(4)+X(5)))
A(5)=2.0*HFF*WFF
YA(1)=0.5*X(1)
YA(2)=X(1)+HFC/3.0
YA(3)=0.5*H
YA(4)=X(2)+0.5*(H-X(2)-X(3))
YA(5)=YA(4)
IA(1)=A(1)*(X(1)**2)/12.0
IA(2)=A(2)*(HFC**2)/18.0
IA(3)=A(3)*(H**2)/12.0
IA(4)=A(4)*((H-X(2)-X(3))**2)/12.0
IA(5)=A(5)*(HFF**2/18.0+(0.5*(H-X(2)-X(3))-HFF/3.0)**2)
AC=0.0
YC=0.0
IC=0.0
DO 5 I=1, 5
AC=AC+A(I)
YC=YC+A(I)*YA(I)
IC=IC+IA(I)
5 CONTINUE
YC=YC/AC
DO 10 I=1, 5
IC=IC+A(I)*(YC-YA(I))**2
10 CONTINUE
KB=IC/(AC*YC)
KT=IC/(AC*(H-YC))
C JACKING STRESS
FJ=0.7*FS
C PRESTRESS AT MID SPAN AT TRANSFER
FI=FJ*EXP(-1.0*(WC*SP+0.04*FCO*X(6)/SP))
C EFFECTIVE PRESTRESS
FSE=FI-227.558
C DEAD LOAD MOMENT
WG=1.0E-05*UWC*AC
MG=0.125*WG*(SP**2)
C SUPERIMPOSED MOMENT
WS=1.0E-03*WSS*WT+0.1*WR
MS=0.125*WS*(SP**2)
C TOTAL MOMENT
MT=MG+MS+MLL
C ALLOWABLE MOMENT
FTT=3.0*SQRT(145.045*FCI)
IF(FTT.GT.200.0)FTT=200.0
FTT=4.448*FTT/(25.4**2)

```

```

FCT=0.55*FCI
FCW=0.6*FC
FTW=6.0*SQR(145.045*FC)
FTW=4.448*FTW/(25.4**2)
C   NORMAL STRESS CONSTRAINTS AT TRANSFER
G(1)=X(6)-KB-(1.0E4*MG+FTT*AC*KB)/(FI*X(7))
G(2)=X(6)+KT-(1.0E4*MG+FCT*AC*KT)/(FI*X(7))
C   NORMAL STRESS CONSTRAINTS UNDER SERVICE LOAD
G(3)=KB-X(6)+(1.0E4*MT-FCW*AC*KB)/(FSE*X(7))
G(4)=-X(6)-KT+(1.0E4*MT-FTW*AC*KT)/(FSE*X(7))
G(5)=X(6)+KT-(1.0E4*MG+0.4*FC*AC*KT)/(FSE*X(7))
C   ULTIMATE MOMENT CAPACITY COMPUTATION
IF(X(1).LE.X(2)) THEN
TF(1)=X(1)
TF(2)=X(2)
BW(1)=WT-2.0*X(5)
ELSE
TF(1)=X(2)
TF(2)=X(1)
BW(1)=2.0*(X(4)+X(5))
END IF
BW(2)=2.0*X(4)
ASR=X(7)
D=YC+X(6)
BT=WT
ASF(1)=0.0
ASF(2)=0.0
MF=0.0
R=ASR/(WT*D)
FSU=FS*(1.0-BS*FS*R/(B1*FC))
DO 15 I=1,2
IF(R*FSU*D/(0.85*FC).LT.TF(I))GO TO 16
ASF(I)=0.85*FC*TF(I)*(BT-BW(I))/FSU
ASR= ASR-ASF(I)
R=ASR/(BW(I)*D)
MF=MF+1.0E-04*ASF(I)*FSU*(D-0.5*TF(I))
BT=BW(I)
15 CONTINUE
16 MN=MF+1.0E-04*ASR*FSU*D*(1.0-0.6*R*FSU/FC)
MULT=1.3*(MG+MS+1.67*MLL)
C   ULTIMATE STRENGTH CONSTRAINT
G(6)=MULT-0.9*MN
C   MAXIMUM PRESTRESSING STEEL CONSTRAINTS
G(7)=R*FSU/FC-0.36*B1
FR=190.5*SQR(FC/4.448)
FR=4.448*FR/645.16
C   CRACKING MOMENTS
MCR=1.0E-04*(FR*KT*AC+FSE*X(7)*KT+FSE*X(6)*X(7))-MG
C   MINIMUM PRESTRESSING STEEL CONSTRAINTS
G(8)=1.2*MCR-0.9*MN
DF=1.0E5*(2812.5*MG+3125.0*MS+2.0*1.19*(121.61458*SP**2+1668.0*SP)
9-0.2552083*FSE*X(6)*X(7))*SP**2/(EC*IC)
C   DEFLECTION CONSTRAINT
G(9)=DF-1.25*SP
C   TRANSVERSE BENDING MOMENT
MGC=0.5E-06*UWC*(X(1)*X(5)**2+HFC*WFC**2/3.0)
MSC=0.5E-04*WSS*X(5)**2+0.01*WR*X(5)
XX=0.01*X(5)-0.7048
EX=0.8*XX+1.143
MLLC=1.3*71.168*XX/EX
MULTC=1.3*(MGC+MSC+1.67*MLLC)
RB=0.85*B1*FC*(0.003/(0.003+FY/ES))/FY
RMAX=0.75*RB

```

```

V=1.0E3*RMAX*FY*(1.0-0.6*RMAX*FY/FC)
D1=0.01*X(1)-0.05
C TRANSVERSE BENDING MOMENT CONSTRAINTS
G(10)=MULTC-V*D1**2
C SIDE CONSTRAINTS
G(11)=X(1)+HFC-70.0
G(12)=20.0-X(1)
G(13)=(WT-2.0*(X(4)+X(5)+wff))/30.0-X(2)
IF((WT-2.0*(X(4)+X(5)+wff))/30.0.LT.20.0)G(13)=20.0-X(2)
G(14)=(WT-2.0*(X(4)+X(5)+wff))/30.0-X(3)
IF((WT-2.0*(X(4)+X(5)+wff))/30.0.LT.15.0)G(14)=15.0-X(3)
G(15)=25.0-X(4)
G(16)=2.0*HFF-(H-X(2)-X(3))
G(17)=2.0*WFF-(WT-2.0*(X(4)+X(5)))
G(18)=175.0-X(5)
G(19)=X(5)-275.0
C MAXIMUM PRACTICAL ECCENTRICITY
G(20)=X(6)-(H-YC-10.0)
RETURN
END

SUBROUTINE GRACON(X,L,GRDG)
IMPLICIT REAL (M)
REAL IC,KT,KB
DIMENSION A(5),YA(5),TF(2),BW(2),ASF(2)
DIMENSION DA(5,5),DYA(5,5),DAC(5),DYC(5),DIC(5),DKB(5),DKT(5)
DIMENSION DD(7),DTF(7,2),DBW(7,2),DBT(7),DASF(7,2)
DIMENSION DASR(7),DMN(7),DR(7),DFSU(7)
DIMENSION X(7),L(20),GRDG(20,7)
COMMON /BLK1/WFC,HFC,WFF,HFF,WT,H
COMMON /BLK2/A,YA,AC,YC,IC,KT,KB
COMMON /BLK3/WSS,WR,MG,MT,SP
COMMON /BLK4/FS,FI,FSE,BS,UWC,FC,EC,B1
COMMON /BLK5/TF,BW,D,ASF,FR,DF,V,ASR,R
COMMON /BLK7/FTT,FCT,FCW,FTW,FCO,FSU,BT,D1,XX,EX
COMMON /BLK9/DA,DYA,DAC,DYC,DIC,DKB,DKT,CK
COMMON /BLK10/DD,DTF,DBW,DBT,DASF,DASR,DMN,DR,DFSU
COMMON //I,J,K
DO 5 J=1,5
DO 10 I=1,5
DA(J,I)=0.0
DYA(J,I)=0.0
10 CONTINUE
DAC(J)=0.0
DYC(J)=0.0
5 CONTINUE
DO 12 J= 1,20
DO 12 I = 1,7
GRDG(J,I)=0.0
12 CONTINUE
C DERIVATIVE OF THE SEGMENTED AREAS WITH RESPECT TO X
DA(1,1)=2.0*X(5)
DA(5,1)=2.0*X(1)
DA(5,3)=-2.0*H
DA(2,4)=WT-2.0*(X(4)+X(5))
DA(3,4)=DA(2,4)
DA(4,4)=2.0*(H-X(2)-X(3))
DA(5,4)=DA(4,4)
C DERIVATIVE OF THE SEGMENTED CENTROID FROM THE TOP FIBER WITH RESPECT TO X
DYA(1,1)=0.5
DYA(1,2)=1.0
DYA(2,4)=0.5

```

```

DYA(3,4)=-0.5
DYA(2,5)=0.5
DYA(3,5)=-0.5
C DERIVATIVES OF MOMENT OF INERTIA OF SEGMENTS
C ABOUT THEIR OWN CENTROID WITH RESPECT TO X
DIC(1)=0.25*A(1)*X(1)
DIC(2)=-0.25*(H-X(2)-X(3))*(A(4)+2.0*A(5))+HFF*A(5)/3.0
DIC(3)=DIC(2)
DIC(4)=(H-X(2)-X(3))**3/6.0
DIC(5)=DIC(4)+(X(1)**3-H**3)/6.0
C DERIVATIVES OF HTE TOTAL CROSS SECTIONAL PROPERTIES
DO 15 J=1,5
DO 20 I=1,5
DAC(J)=DAC(J)+DA(J,I)
DYC(J)=DYC(J)+YA(I)*DA(J,I)+A(I)*DYA(J,I)
DIC(J)=DIC(J)-2.0*(YC-YA(I))*A(I)*DYA(J,I)+DA(J,I)*(YC-YA(I))**2
20 CONTINUE
DYC(J)=(DYC(J)-YC*DAC(J))/AC
DO 25 I=1,5
DIC(J)=DIC(J)+2.0*(YC-YA(I))*A(I)*DYC(J)
25 CONTINUE
DKB(J)=(DIC(J)-KB*(YC*DAC(J)+AC*DYC(J)))/(YC*AC)
DKT(J)=(DIC(J)+KT*(AC*DYC(J)+(H-YC)*DAC(J)))/((H-YC)*AC)
C GRADIENT OF THE NORMAL STRESS CONSTRAINT
15 CONTINUE
CK=0.125*UWC*SP**2
IF(L(1).EQ.1) THEN
DO 35 I=1,5
GRDG(1,I)=- (FTT*AC*DKB(I)+DAC(I)*(0.1*CK+FTT*KB))/(FI*X(7))
GRDG(1,I)=GRDG(1,I)-DKB(I)
35 CONTINUE
GRDG(1,6)=1.0-0.04*FCO*(1.0E4*MG+FTT*AC*KB)/(SP*FI*X(7))
GRDG(1,7)=(1.0E4*MG+FTT*AC*KB)/(FI*X(7)**2)
ENDIF
IF(L(2).EQ.1) THEN
DO 40 I=1,5
GRDG(2,I)=(1.0-FTT*AC/(FI*X(7)))*DKT(I)-(0.1*CK+FCT*KT)*DAC(I)/(FI
9*X(7))
40 CONTINUE
GRDG(2,6)=1.0-0.04*FCO*(1.0E4*MG+FCT*AC*KT)/(SP*FI*X(7))
GRDG(2,7)=(1.0E4*MG+FCT*AC*KT)/(FI*X(7)**2)
ENDIF
IF(L(3).EQ.1) THEN
DO 45 I=1,5
GRDG(3,I)=(1.0-FCW*AC/(FSE*X(7)))*DKB(I)+(0.1*CK-FCW*KB)*DAC(I)/(F
9SE*X(7))
45 CONTINUE
GRDG(3,6)=-1.0+0.04*FCO*FI*(1.0E4*MT-FCW*AC*KB)/(SP*X(7)*FSE**2)
GRDG(3,7)=(-1.0E4*MT+FCW*AC*KB)/(FSE*X(7)**2)
ENDIF
IF(L(4).EQ.1) THEN
DO 50 I=1,5
GRDG(4,I)=(-1.0-FTW*AC/(FSE*X(7)))*DKT(I)+(0.1*CK-FTW*KT)*DAC(I)/(
9FSE*X(7))
50 CONTINUE
GRDG(4,6)=-1.0+0.04*FCO*FI*(1.0E4*MT-FTW*AC*KT)/(SP*X(7)*FSE**2)
GRDG(4,7)=(-1.0E4*MT+FTW*AC*KT)/(FSE*X(7)**2)
ENDIF
IF(L(5).EQ.1) THEN
DO 55 I=1,5
GRDG(5,I)=(1.0-0.4*FC*AC/(FSE*X(7)))*DKT(I)-(0.1*CK+0.4*FC*KT)*DAC
9(I)/(FSE*X(7))
55 CONTINUE

```

```

GRDG(5,6)=1.0-0.04*FCO*FI*(1.0E4*MG+0.4*FC*AC*KT)/(SP*X(7)*FSE**2)
GRDG(5,7)=(1.0E4*MG+0.4*FC*AC*KT)/(FSE*X(7)**2)
ENDIF
IF(L(6).EQ.1.OR.L(7).EQ.1.OR.L(8).EQ.1)THEN
C  DERIVATIVES OF ULTIMATE MOMENT CAPACITY WITH RESPECT TO X
DO 60 J=1,7
DO 65 I=1,2
DTF(J,I)=0.0
DBW(J,I)=0.0
DASF(J,I)=0.0
65 CONTINUE
DBT(J)=0.0
DASR(J)=0.0
DMN(J)=0.0
60 CONTINUE
DASR(7)=1.0
ASR=X(7)
BT=WT
R=ASR/(WT*D)
FSU=FS*(1.0-BS*FS*R/(B1*FC))
DO 70 I=1,5
DD(I)=DYC(I)
DR(I)=-1.0*R*DD(I)/D
DFSU(I)=-1.0*BS*DR(I)*FS**2/(FC*B1)
70 CONTINUE
DD(6)=1.0
DD(7)=0.0
DR(6)=-1.0*R/D
DR(7)=1.0/(WT*D)
DFSU(6)=-1.0*BS*DR(6)*FS**2/(B1*FC)
DFSU(7)=-1.0*BS*DR(7)*FS**2/(B1*FC)
IF(X(1).LE.X(2))THEN
DTF(1,1)=1.0
DTF(2,2)=1.0
DBW(5,1)=-2.0
ELSE
DTF(2,1)=1.0
DTF(1,2)=1.0
DBW(4,1)=2.0
DBW(5,1)=2.0
ENDIF
DBW(4,2)=2.0
DO 75 I=1,2
SSS=R*FSU*D/(0.85*FC)
IF(SSS.LE.TF(I))GO TO 78
ASR=ASR-ASF(I)
R=ASR/(BW(I)*D)
DO 80 J=1,7
DASF(J,I)=.85*FC*(TF(I)*(DBT(J)-DBW(J,I))+(BT-BW(I))*(FSU*DTF(J,I)
9-TF(I)*DFSU(J))/FSU)/FSU
DASR(J)=DASR(J)-DASF(J,I)
DR(J)=(BW(I)*D*DASR(J)-ASR*(D*DBW(J,I)+BW(I)*DD(J)))/(BW(I)*D)**2
DMN(J)=DMN(J)+1.0E-04*(FSU*DASF(J,I)+ASF(I)*DFSU(J))*(D-0.5*TF(I)
9+1.0E-04*ASF(I)*FSU*(DD(J)-0.5*DTF(J,I))
DBT(J)=DBW(J,I)
80 CONTINUE
BT=BW(I)
75 CONTINUE
78 DO 85 J=1,7
DMN(J)=DMN(J)+1.0E-04*((1.0-0.6*R*FSU/FC)*(D*(FSU*DASR(J)+ASR*DFSU
9(J))+ASR*FSU*DD(J))-0.6*ASR*FSU*D*(FSU*DR(J)+R*DFSU(J))/FC)
85 CONTINUE
C  GRADIENT OF THE ULTIMATE STRENGTH CONSTRAINT

```

```

      IF (L(6).EQ.1) THEN
      DO 90 I=1,5
      GRDG(6,I)=1.3E-05*CK*DAC(I)-0.9*DMN(I)
90  CONTINUE
      GRDG(6,6)=-0.9*DMN(6)
      GRDG(6,7)=-0.9*DMN(7)
      ENDIF
C    GRADIENT OF THE MAX. PRESTRESSING STEEL CONSTRAINTS
      IF (L(7).EQ.1) THEN
      DO 95 I=1,7
      GRDG(7,I)=(FSU*DR(I)+R*DFSU(I))/FC
95  CONTINUE
      ENDIF
C    GRADIENT OF THE MIN PRESTRESSING STEEL CONSTRAINT
      IF (L(8).EQ.1) THEN
      DO 100 I=1,5
      GRDG(8,I)=1.2E-04*((FR*AC+FSE*X(7))*DKT(I)+(FR*KT-0.1*CK)*DAC(I))-
      *.9*DMN(I)
100 CONTINUE
      GRDG(8,6)=1.2E-04*X(7)*(-0.04*FCO*FI*(KT+X(6))/SP+FSE)-0.9*DMN(6)
      GRDG(8,7)=1.2E-04*FSE*(KT+X(6))-0.9*DMN(7)
      ENDIF
      ENDIF
C    GRADIENT OF DEFLECTION CONSTRAINTS
      IF (L(9).EQ.1) THEN
      DO 105 I=1,5
      GRDG(9,I)=-1.0*DF*DIC(I)/IC+2812.5*CK*DAC(I)*SP**2/(EC*IC)
105 CONTINUE
      GRDG(9,6)=-.2552083E5*X(7)*(FSE-0.04*FCO*FI*X(6)/SP)*SP**2/(EC*IC)
      GRDG(9,7)=-0.2552083E5*FSE*X(6)*SP**2/(EC*IC)
      ENDIF
      ENDIF
C    GRADIENT OF TRANSVERSE BENDING MOMENT CONSTRAINTS
      IF (L(10).EQ.1) THEN
      XX=0.01*X(5)-0.7048
      EX=0.8*XX+1.143
      D1=0.01*X(1)-0.05
      GRDG(10,1)=0.5E-06*UWC*X(5)**2-0.02*V*D1
      GRDG(10,5)=1.0E-06*X(5)*X(1)+0.0001*WSS*X(5)+0.01*WR-1.3*.71168*(E
9X-0.88*XX)/EX**2
      ENDIF
      ENDIF
C    GRADIENT OF SIDE CONSTRAINTS
      IF (L(11).EQ.1) GRDG(11,1)=1.0
      IF (L(12).EQ.1) GRDG(12,1)=-1.0
      IF (L(13).EQ.1) THEN
      GRDG(13,2)=-1.0
      IF ((WT-2.0*(X(4)+X(5)+wff))/30.0.GT.20.0) THEN
      GRDG(13,4)=-2.0/30.0
      GRDG(13,5)=GRDG(13,4)
      ENDIF
      ENDIF
      IF (L(14).EQ.1) THEN
      GRDG(14,3)=-1.0
      IF ((WT-2.0*(X(4)+X(5)+wff))/30.0.GT.15.0) THEN
      GRDG(14,4)=-2.0/30.0
      GRDG(14,5)=GRDG(14,4)
      ENDIF
      ENDIF
      IF (L(15).EQ.1) GRDG(15,4)=-1.0
      IF (L(16).EQ.1) THEN
      GRDG(16,2)=1.0
      GRDG(16,3)=1.0
      ENDIF
      IF (L(17).EQ.1) THEN

```

```

GRDG(17,4)=2.0
GRDG(17,5)=2.0
ENDIF
IF(L(18).EQ.1)GRDG(18,5)=-1.0
IF(L(19).EQ.1)GRDG(19,5)=1.0
IF(L(20).EQ.1)THEN
DO 110 I=1,5
GRDG(20,I)=DYC(I)
110 CONTINUE
GRDG(20,6)=1.0
ENDIF
RETURN
END

SUBROUTINE LINPRO(LL,L,GRDG,GRDZ,S,ZZ)
DIMENSION AA(15,31),B(15),C(31),C1(31),IBV(15),NBV(23)
DIMENSION LN(8),LX(7),NP(15)
DIMENSION L(20),GRDG(20,7),GRDZ(7),S(7)
COMMON /BLK11/AA,B,C,C1,IBV,NBV,LN,LX,NP
COMMON /BLK12/ZZ1,NM,NK,NN,II,IT,LK,IS,LUB,N
COMMON //I,J,K
C FORMULATION OF THE LINEAR SYSTEM
C MATRIX AA,VECTOR B AND COST COEFFICIENT VECTOR C
NM=N+LL+1
NK=2*(N+1)+LL
DO 5 I=1,NM
DO 10 J=1,NK+NM
AA(I,J)=0.0
10 CONTINUE
B(I)=0.0
5 CONTINUE
DO 7 J=1,NM+NK
C(j)=0.0
7 C1(j)=0.0
K=0
DO 15 J=1,20
IF(L(J).EQ.1)THEN
K=K+1
LX(K)=J
ENDIF
15 CONTINUE
DO 20 I=1,N
AA(I,I)=1.0
B(I)=2.0
20 CONTINUE
DO 25 I=1,LL
NN=LX(I)
DO 30 K=1,N
AA(I+N,K)=GRDG(NN,K)
B(I+N)=B(I+N)+AA(I+N,K)
30 CONTINUE
25 CONTINUE
DO 35 K=1,N
AA(NM,K)=GRDZ(K)
B(NM)=B(NM)+AA(NM,K)
35 CONTINUE
DO 40 K=N+1,NM
AA(K,N+1)=1.0
40 CONTINUE
DO 45 I=1,NM
AA(I,I+N+1)=1.0
45 CONTINUE

```

```

C(N+1)=-1.0
ZZ=0.0
DO 50 I=1,NK
NBV(I)=0
50 CONTINUE
DO 55 I=1,NM
IBV(I)=I+N+1
55 CONTINUE
II=0
DO 60 I=N+1,NM
IF(B(I).LT.0.0)THEN
II=II+1
LN(II)=I
ENDIF
60 CONTINUE
IF(II.EQ.0)GO TO 142
C ARTIFIAL VARIABLE
ZZ1=0.0
DO 65 I=1,II
NN=LN(I)
DO 70 K=1,N+1
AA(NN,K)=-AA(NN,K)
70 CONTINUE
AA(NN,NN+N+1)=-1.0
B(NN)=-B(NN)
65 CONTINUE
DO 75 I=1,NM
AA(I,NK+I)=1.0
75 CONTINUE
DO 80 I=1,NK
DO 80 K=1,NM
C1(I)=C1(I)-AA(K,I)
80 CONTINUE
DO 85 I=1,NM
IBV(I)=NK+I
ZZ1=ZZ1-B(I)
85 CONTINUE
88 IT=1
DO 90 I=2,NK
IF(C1(IT).GT.C1(I))IT=I
90 CONTINUE
IF(C1(IT).GE.0.0)GO TO 135
LUB=0
LK=0
DO 100 I=1,NM
IF(AA(I,IT).GT.0.0)THEN
LK=LK+1
NP(LK)=I
ENDIF
100 CONTINUE
IF(LK.EQ.0)GO TO 300
IS=NP(1)
IF(LK.GT.1) THEN
DO 105 I=2,LK
NN=NP(I)
IF(B(NN)/AA(NN,IT).LT.B(IS)/AA(IS,IT))IS=NP(I)
105 CONTINUE
ENDIF
DO 110 K=1,NK+NM
IF(K.NE.IT)THEN
DO 115 I=1,NM
IF(I.NE.IS)THEN
AA(I,K)=AA(I,K)-AA(I,IT)*AA(IS,K)/AA(IS,IT)

```

```

ENDIF
115 CONTINUE
C(K)=C(K)-C(IT)*AA(IS,K)/AA(IS,IT)
C1(K)=C1(K)-C1(IT)*AA(IS,K)/AA(IS,IT)
ENDIF
110 CONTINUE
DO 120 I=1,NM
IF(I.NE.IS)THEN
B(I)=B(I)-AA(I,IT)*B(IS)/AA(IS,IT)
ENDIF
120 CONTINUE
ZZ=ZZ-C(IT)*B(IS)/AA(IS,IT)
ZZ1=ZZ1-C1(IT)*B(IS)/AA(IS,IT)
C(IT)=0.0
C1(IT)=0.0
DO 125 I=1,NM
IF(I.NE.IS)AA(I,IT)=0.0
125 CONTINUE
DO 130 K=1,NK+NM
IF(K.NE.IT)AA(IS,K)=AA(IS,K)/AA(IS,IT)
130 CONTINUE
B(IS)=B(IS)/AA(IS,IT)
AA(IS,IT)=1.0
IBV(IS)=IT
GO TO 88
135 IF(ZZ1.GT.1.0E-3) GO TO 350
142 IT=1
DO 150 J=2,NK
IF(C(IT).GT.C(J))IT=J
150 CONTINUE
IF(C(IT).GE.0.0)GO TO 201
LUB=0
LK=0
DO 155 I=1,NM
IF(AA(I,IT).GT.0.0)THEN
LK=LK+1
NP(LK)=I
ENDIF
155 CONTINUE
IF(LK.EQ.0)GO TO 300
IS=NP(1)
IF(LK.GT.1)THEN
DO 160 I=2,LK
NN=NP(I)
IF(B(NN)/AA(NN,IT).LT.B(IS)/AA(IS,IT))IS=NP(I)
160 CONTINUE
ENDIF
DO 165 K=1,NK
IF(K.NE.IT)THEN
DO 170 I=1,NM
IF(I.NE.IS)THEN
AA(I,K)=AA(I,K)-AA(I,IT)*AA(IS,K)/AA(IS,IT)
ENDIF
170 CONTINUE
C(K)=C(K)-C(IT)*AA(IS,K)/AA(IS,IT)
ENDIF
165 CONTINUE
DO 175 I=1,NM
IF(I.NE.IS)THEN
B(I)=B(I)-AA(I,IT)*B(IS)/AA(IS,IT)
ENDIF
175 CONTINUE
ZZ=ZZ-C(IT)*B(IS)/AA(IS,IT)

```

```

      C(IT)=0.0
      DO 180 I=1,NM
      IF(I.NE.IS)AA(I,IT)=0.0
180  CONTINUE
      DO 185 K=1,NK
      IF(K.NE.IT)AA(IS,K)=AA(IS,K)/AA(IS,IT)
185  CONTINUE
      B(IS)=B(IS)/AA(IS,IT)
      AA(IS,IT)=1.0
      IBV(IS)=IT
      GO TO 142
201  DO 190 I=1,N
      S(K)=0.0
190  CONTINUE
      DO 195 I=1,NM
      DO 195 K=1,N
      IF(IBV(I).EQ.K)S(K)=B(I)
195  CONTINUE
      DO 200 K=1,N
      S(K)=S(K)-1.0
200  CONTINUE
      RETURN
300  LUB=1
      write(*,*) 'UNBOUNDED SOLN'
      RETURN
350  write(*,*) 'NO FEAS.SOLN'
      RETURN
      END

```