



**Addis Ababa University**

**Addis Ababa Institute of Technology**

**School of Electrical and Computer Engineering**

**Design and Performance Analysis of Micro strip patches Array  
Antennas for Long Term Evolution (LTE)**

A thesis submitted to Addis Ababa Institute of Technology, School of Graduate Studies, Addis Ababa university

In partial fulfillment of the requirement for the **Degree of Master of Science in Electrical and Computer Engineering (communication Engineering)**.

**By: Juhar Muhammed**

**Advisor: Prof. Mohammed Abdo**

**Addis Ababa, Ethiopia**

**March, 2017**

**Addis Ababa University**

**Addis Ababa Institute of Technology**

**School of Electrical and Computer Engineering**

**Design and Performance Analysis of Micro strip patches Array**

**Antennas for Long Term Evolution (LTE)**

**By: Juhar Muhammed Alyu**

APPROVED BY BOARD OF EXAMINERS

|  |           |
|--|-----------|
| _____                                      | _____     |
| Chairman, Department of Graduate Committee | Signature |
| <u>Prof. Mohammed Abdo</u>                 | _____     |
| Name of Advisor                            | Signature |
| _____                                      | _____     |
| Name of External Examiner                  | Signature |
| _____                                      | _____     |
| Name of Internal Examiner                  | Signature |

## **Acknowledgment**

I would like to express my appreciation to my advisor: professor. Mohammed Abdo. I will like to say special thanks to him for his time, patience, and understanding and his continual guidance in my work. Also, thanks to the School of Electrical and Computer Engineering for it supported me. I would like to express my sincerest gratitude to Debre Tabor University for offering me the scholarship to continue in my academic carrier. I express my thanks and appreciation to my family for their understanding, motivation and patience. Lastly, but in no sense the least, I am thankful to all colleagues and friends who made my stay at the university a memorable and valuable experience.

## **Declaration**

I declare that this thesis is my work and that all source materials used for this thesis have been properly acknowledged. This thesis has been submitted in partial fulfillment of the requirements for M.Sc. degree in communication Engineering at Addis Ababa University. I earnestly declare that this thesis is not submitted to any other institution any where for the award of any academic degree, diploma, or certificate.

Name: Juhar.Muhammed Alyu

Signature:\_\_\_\_\_

Place: Addis Ababa, Ethiopia

Date of Submission:\_\_\_\_\_

This thesis has been submitted for my approval as a university advisor.

Name: Prof. Mohammed Abdo

Signature:\_\_\_\_\_

Place: Addis Ababa, Ethiopia

Date:\_\_\_\_\_

## Abstract

Micro strip patches antenna are playing an important role in wireless communication systems because of their many advantages like light weight, low profile, low cost, easy integration with planar structure and easy fabrication. So, it is very much essential to know all the aspects of micro strip antennas. The main objective of this thesis is to discuss the design and performance issues of micro strip patch array antennas. The design issues include micro strip antenna dimensions, feeding techniques and various polarization mechanisms whereas the performance issues include return loss, bandwidth issues directivity and radiation pattern of micro strip patch array antennas. In this thesis, a micro strip fed patches antenna array for long term evolution (LTE) application is designed using the MATLAB software. To design it, Standard formulas are used to calculate different parameters of the antenna. After design the array, some parameters are varied during simulation to get good performances. The proposed antenna is designed to work at 2.6GHz frequency band. A fractional bandwidth of 4.25%, which was not close to the desired 10% and a directivity of 4.66dB were attained single patch antenna. This may have been brought about by poor impedance matching and a high level of spurious feed radiation and surface waves. A way of improving the bandwidth, radiation pattern and minimize the return loss would have been expected for effective communication. To achieve this requirement we are designed (4x1) rectangular micro strip patch array antennas with micro strip line feeding based on quarter wave impedance matching technique using Mat lab software. The performance of the designed antenna is then compared with the single patch rectangle antenna in term of return loss, Voltage Standing Wave Ratio (VSWR), bandwidth, directivity, radiation pattern. After carried out computer simulation, rectangular micro strip patch array antenna offers the highest bandwidth efficiency of (as high as 12.5%), somewhat good directivity (9.66dB), minimum return loss (as low as -11.5dB) and has good radiation pattern. This is a fairly high though directivity increase and minimize loss could have been studied through use of different substrate material and thickness. The array antenna can be fabricate on the substrate type FR-4 with dielectric constant of 4.4 and thickness of 1.6mm respectively.

**Keywords:** Rectangular Micro strips Array antenna, long term evolution (LTE), return loss and micro strip feed line.

# Contents

|   |            |
|---|------------|
| <b>Acknowledgment</b>                                       | <b>iii</b> |
| <b>Declaration</b>  | <b>iv</b>  |
| <b>Abstract</b>   | <b>v</b>   |
| <b>List of Symbol</b>                                       | <b>vii</b> |
| <b>List of Abbreviation</b>                                 | <b>ix</b>  |
| <b>List of Tables</b>                                       | <b>x</b>   |
| <b>List of Figures</b>                                      | <b>xi</b>  |
| <b>1 Introduction</b>                                       | <b>1</b>   |
| 1.1 Background of the Study . . . . .                       | 1          |
| 1.2 Objective of the Study . . . . .                        | 3          |
| 1.2.1 General objective of the study . . . . .              | 3          |
| 1.2.2 Specific objectives of the study . . . . .            | 3          |
| 1.3 Motivation of the Thesis . . . . .                      | 3          |
| 1.4 Methodology . . . . .                                   | 5          |
| 1.4.1 Proposed Work . . . . .                               | 6          |
| 1.5 Literature Review . . . . .                             | 7          |
| 1.6 Organization of the Thesis . . . . .                    | 9          |
| <b>2 Review of Long Term Evolution Mobile Technology</b>    | <b>10</b>  |
| 2.1 LTE Overview and Target System Requirements . . . . .   | 10         |
| 2.2 Performance Goals for LTE . . . . .                     | 12         |
| 2.3 Antenna Design Challenges for 4G/LTE Handsets . . . . . | 13         |
| 2.4 Major requirements for LTE . . . . .                    | 13         |
| <b>3 Micro strip Patches Antenna</b>                        | <b>14</b>  |

|        |  |    |
|--------|--|----|
| 3.1    | Introduction . . . . .   | 14 |
| 3.2    | Advantages and Disadvantages . . . . .                             | 15 |
| 3.2.1  | Advantages of micro strip antennas . . . . .                       | 15 |
| 3.2.2  | Disadvantages of micro strip antennas. . . . .                     | 15 |
| 3.3    | Antenna Array and Feed Techniques . . . . .                        | 15 |
| 3.3.1  | Micro strip Line Feed . . . . .                                    | 17 |
| 3.3.2  | Coaxial Feed . . . . .   | 19 |
| 3.3.3  | Aperture Coupled Feed . . . . .                                    | 19 |
| 3.3.4  | Proximity Coupled Feed . . . . .                                   | 20 |
| 3.4    | Methods of analysis of Micro strip Patch Antenna . . . . .         | 22 |
| 3.4.1  | Transmission Line Model Analysis for a Rectangular Patch . . . . . | 22 |
| 3.4.2  | Cavity Mode . . . . .  | 25 |
| 3.5    | Overview of the Antenna Parameters . . . . .                       | 25 |
| 3.5.1  | Basic Principles of Operation . . . . .                            | 25 |
| 3.5.2  | Basic Characteristics . . . . .                                    | 26 |
| 3.5.3  | Radiation Pattern . . . . .  | 27 |
| 3.5.4  | Return loss . . . . .  | 29 |
| 3.5.5  | S-parameters . . . . .   | 30 |
| 3.5.6  | Impedance Matching . . . . .                                       | 30 |
| 3.5.7  | Radiation Efficiency and Quality Factor . . . . .                  | 31 |
| 3.5.8  | Bandwidth . . . . .  | 32 |
| 3.5.9  | Radiation Intensity (U) . . . . .                                  | 32 |
| 3.5.10 | Linear Polarization . . . . .                                      | 32 |
| 3.6    | Micro strips Array . . . . .                                       | 33 |
| 3.7    | Functional Blocks of micro strip patch Array Antenna. . . . .      | 33 |
| 3.7.1  | Feed Network. . . . .  | 34 |
| 3.7.2  | Phase Scanning Circuitry . . . . .                                 | 34 |
| 3.7.3  | Controlling Parameters of an Array Antenna System . . . . .        | 35 |
| 3.7.4  | Geometrical orientation of the overall array . . . . .             | 36 |
| 3.7.5  | Relative separation between the elements . . . . .                 | 36 |
| 3.7.6  | Excitation amplitude of the individual element . . . . .           | 36 |
| 3.7.7  | Excitation phase of the individual element . . . . .               | 36 |
| 3.7.8  | Relative pattern of the individual element . . . . .               | 36 |
| 3.8    | Array Factor (AF) . . . . .  | 36 |

|          |   |           |
|----------|---|-----------|
| 3.9      | Array Design . . . . .  | 37        |
| 3.10     | Mutual Coupling in Antenna Array . . . . .                          | 37        |
| 3.11     | Need for Antenna Array . . . . .                                    | 38        |
| <b>4</b> | <b>Design of Rectangular Micro strip Patches Array Antenna</b>      | <b>39</b> |
| 4.1      | Introduction . . . . .  | 39        |
| 4.2      | Design parameters . . . . .   | 39        |
| 4.2.1    | Substrate Material . . . . .  | 39        |
| 4.2.2    | patch Parameters . . . . .  | 40        |
| 4.2.3    | Width and Length . . . . .  | 40        |
| 4.3      | Design Specifications . . . . .                                     | 40        |
| 4.3.1    | Single Micro strip Patch Antenna Design . . . . .                   | 41        |
| 4.3.2    | Patch Calculations . . . . .  | 42        |
| 4.3.3    | Ground plane dimensions calculation (Lg and Wg) . . . . .           | 42        |
| 4.4      | Micro strip Discontinuities . . . . .                               | 43        |
| 4.4.1    | Bends . . . . .   | 43        |
| 4.4.2    | Step Width Junction . . . . .                                       | 43        |
| 4.4.3    | T-Junction . . . . .  | 44        |
| 4.4.4    | Radiation Pattern Calculation . . . . .                             | 45        |
| 4.4.5    | Micro strip Patches Array Antenna Design . . . . .                  | 46        |
| 4.5      | Array Calculation . . . . .   | 47        |
| 4.5.1    | Calculation of the Impedance for Quarter-Wave Transformer . . . . . | 48        |
| <b>5</b> | <b>Results and Discussion</b>                                       | <b>50</b> |
| 5.1      | Introduction . . . . .  | 50        |
| 5.2      | Results and Discussion . . . . .                                    | 50        |
| <b>6</b> | <b>Conclusion and Future work</b>                                   | <b>60</b> |
| 6.1      | Introduction . . . . .  | 60        |
| 6.2      | Conclusion . . . . .  | 60        |
| 6.3      | Future Work . . . . .   | 61        |
|          | <b>References</b>   | <b>62</b> |
| <b>A</b> | <b>appendix</b>   | <b>65</b> |
|          | Appendix A: Derivation of Conductance . . . . .                     | 65        |
|          | Appendix B: Sample MATLAB Code . . . . .                            | 68        |

## List of Symbols

|                |  |
|----------------|--|
| $\epsilon_r$   | dielectric constant of substrate   |
| $f$            | operating frequency  |
| $\epsilon_e$   | effective dielectric constant  |
| $c$            | free space velocity of light, which is $3 \times 10^8$ m/s                 |
| $h$            | height of dielectric substrate   |
| $W$            | width of the patch   |
| $L$            | length of the patch  |
| $\Delta$       | L patch length extension   |
| $\lambda$      | lambda   |
| $\lambda_2$    | half lambda  |
| $y_0$          | position of the feed from the edge along the direction of the patch length |
| $\delta_{eff}$ | effective loss tangent   |
| $Q_T$          | total antenna quality factor   |
| $Q_d$          | dielectric quality factor  |
| $\omega_r$     | angular resonant frequency   |
| $W_T$          | total energy stored in the patch at resonance                              |
| $Q_{sw}$       | quality factor due to surface waves  |
| $\tan \delta$  | loss tangent of the dielectric   |
| $Q_c$          | conductor quality factor   |
| $q$            | fringing factor  |
| $TEM$          | transverse electric magnetic   |
| $Q_r$          | radiation quality factor   |
| $P_r$          | power radiated from the patch  |
| $\lambda_0$    | free-space wavelength  |
| $ \Gamma $     | reflection coefficient   |
| $V_0^+$        | incident voltage   |
| $V_0^-$        | reflected voltage  |
| $Z_L$          | load impedance   |
| $Z_0$          | characteristic impedance   |
| $\bar{M}_s$    | magnetic current   |
| $\hat{n}$      | outward pointing unit-normal vector at the patch boundary                  |
| $\bar{E}$      | electric field of the cavity mode at the edge of the patch                 |

|           |                                    |
|-----------|------------------------------------|
| $G$       | gain                               |
| $L_{eff}$ | effective length of the patch      |
| $\eta$    | radiation efficiency               |
| $D$       | directivity of the patch antenna   |
| $AF$      | array factor                       |
| $N$       | number of elements                 |
| $BW$      | bandwidth                          |
| $fH$      | frequency high                     |
| $fL$      | frequency low                      |
| $fC$      | frequency center                   |
| $AF$      | planar planar antenna array factor |
| $k$       | wave vector                        |
| $\beta$   | phase difference                   |
| $h$       | dielectric thickness (mm)          |
| $e$       | efficiency                         |
| $\sigma$  | conductivity of the conductor      |

## List of Abbreviations

|                    |  |
|--------------------|--|
| <i>WLAN</i>        | Wireless local Area Networks                                     |
| <i>RF</i>          | Radio Frequency  |
| <i>MIMO</i>        | Multiple Input Multiple Out put                                  |
| <i>IEEE 802.11</i> | International Electrical and Electronics 802.11                  |
| <i>WiMAX</i>       | Worldwide Interoperability for Microwave Access                  |
| <i>HFSS</i>        | High Frequency Simulation Software                               |
| <i>DGS</i>         | Defected Ground Structure  |
| <i>VSWR</i>        | Voltage Standing Wave Ratio                                      |
| <i>CST</i>         | Computer Simulation Technology                                   |
| <i>GSM</i>         | Geographical positioning system for Mobile communication         |
| <i>HPBW</i>        | Half Power Beam Width  |
| <i>LTE</i>         | Long Term Evolution  |
| <i>3GPP</i>        | 3rd Generation Partnership Project                               |
| <i>UTRAN</i>       | Universal Terrestrial Radio Access Network                       |
| <i>HSPA+</i>       | High Speed Packet Access   |
| <i>UMTS</i>        | Universal Mobile Telecommunications System                       |
| <i>WCDMAFDD</i>    | wideband code division multiple access Frequency Division Duplex |
| <i>TDD</i>         | Time Division Duplex   |
| <i>HSDPA</i>       | High Speed Downlink Packet Access                                |
| <i>16QAMUL</i>     | 16 Quadrature Amplitude Modulation Uplink                        |
| <i>64QAMDL</i>     | 64 Quadrature Amplitude Modulation Downlink                      |
| <i>EDGE</i>        | Enhanced Data Rate for Global Evolution                          |
| <i>EMBMS</i>       | Enhanced Multimedia Broadcast/Multicast Services                 |
| <i>FTP</i>         | File Transfer Protocol   |
| <i>VoIP</i>        | Voice over Internet Protocol                                     |
| <i>OFDM</i>        | Orthogonal Frequency Division Multiplexing                       |
| <i>RL</i>          | return loss  |
| <i>SINR</i>        | Interference plus Noise Ratio                                    |
| <i>RFID</i>        | Radio frequency identification                                   |
| <i>GPS</i>         | Global positioning systems                                       |
| <i>EBG</i>         | Electromagnetic Band Gap   |
| <i>SMA</i>         | Surface mount adapter  |

# List of Tables

|          |  |    |
|----------|--|----|
| Table2.1 | Evolution of UMTS specification . . . . .  | 10 |
| Table2.2 | LTE performance requirements. . . . .  | 12 |
| Table3.1 | summarizes the advantages and disadvantages of the four feeding methods [14] . . . . .   | 21 |
| Table4.1 | Single Patch Antenna Design Specifications. . . . .  | 41 |
| Table4.2 | Dimension of Rectangular Patch Antenna. . . . .  | 45 |
| Table4.3 | Dimension of Rectangular Patches Array Antenna. . . . .  | 49 |
| Table5.1 | Comparison of Performance and Result of a RMP antenna for same Thickness $h$ of substrate at same Dielectric constant . . . . .            | 50 |
| Table5.2 | Comparison of Performance and Result of a RMP array antenna for different Thickness $h$ of substrate at same Dielectric constant . . . . . | 51 |

# List of Figures

|            |  |    |
|------------|--|----|
| Figure1.1  | block diagram of communication system . . . . .  | 1  |
| Figure1.2  | flow chart of methodology . . . . .  | 5  |
| Figure1.3  | a generic block diagram of antenna system. . . . .   | 6  |
| Figure3.1  | A Micro strip feed and the equivalent circuit, Micro strip feed at a radiating edge[5] . . . . . | 18 |
| Figure3.2  | Micro strip Line Feed[5] . . . . .   | 18 |
| Figure3.3  | Probe fed Rectangular Micro strip Patch Antenna[5] . . . . .                                     | 19 |
| Figure3.4  | Aperture-coupled feed[5] . . . . .   | 20 |
| Figure3.5  | Proximity-coupled Feed [5] . . . . .   | 21 |
| Figure3.6  | Electric Field Lines[1] . . . . .  | 23 |
| Figure3.7  | Micro strip line and its electric field lines, and effective dielectric constant[1] . . . . .    | 23 |
| Figure3.8  | Physical and effective lengths of rectangular micro strip patch . . . . .                        | 24 |
| Figure3.9  | Side views of Micro strip Patch Antenna[22] . . . . .  | 26 |
| Figure3.10 | Micro strip antenna and coordinate system[1] . . . . .   | 27 |
| Figure3.11 | Electrical current for (1, 0) patch[9] . . . . .   | 28 |
| Figure3.12 | Magnetic current for (1, 0) patch[9] . . . . .   | 28 |
| Figure3.13 | Radiation pattern of a generic directional antenna[9] . . . . .                                  | 29 |
| Figure3.14 | Corporate feed structure for an array system [6]. . . . .  | 34 |
| Figure3.15 | parallel phasers [23] . . . . .  | 35 |
| Figure3.16 | series phasers [23] . . . . .  | 35 |
| Figure4.1  | Patch Antenna with Quarter-Wave Transformer . . . . .  | 41 |
| Figure4.2  | right-angled bends with it equivalent circuit; W is the width of the line [21] . . . . .         | 43 |
| Figure4.3  | Characteristics of the step width junction discontinuity [22] . . . . .                          | 44 |
| Figure4.4  | Junction discontinuity and the Equivalent Circuit [24] . . . . .                                 | 44 |
| Figure4.5  | T-junction discontinuity compensation and minimization of the effect [24] . . . . .              | 45 |
| Figure4.6  | Single Patch Antenna Design Layout. . . . .  | 46 |
| Figure4.7  | Series Feed network . . . . .  | 46 |
| Figure4.8  | Four Elements Array Line Impedance Design Layout . . . . .                                       | 48 |

|            |   |    |
|------------|---|----|
| Figure4.9  | Layout Design of 4x1 Array Antennas . . . . .   | 49 |
| Figure5.1  | 3D directivity of single Patch Antenna . . . . .  | 51 |
| Figure5.2  | 3D directivity of single cosine Antenna element . . . . .   | 52 |
| Figure5.3  | 3D directivity of rectangular patch array Antenna . . . . .                                       | 53 |
| Figure5.4  | 3D directivity of cosine array Antenna element . . . . .  | 53 |
| Figure5.5  | Input impedance characteristics of micro strip patch array antenna . . . . .                      | 54 |
| Figure5.6  | $S_{11}$ (Return Loss) Parameter plot of rectangular patch array antenna for<br>h=1.5mm . . . . . | 55 |
| Figure5.7  | $S_{11}$ (Return Loss) Parameter plot of rectangular patch array antenna for<br>h=1.7mm . . . . . | 55 |
| Figure5.8  | $S_{11}$ (Return Loss) Parameter plot of rectangular patch array antenna for<br>h=1.9mm . . . . . | 56 |
| Figure5.9  | 3D radiation pattern with the array element space $0.25(\lambda)$ . . . . .                       | 57 |
| Figure5.10 | 3D radiation pattern with the array element space $0.3(\lambda)$ . . . . .                        | 57 |
| Figure5.11 | 3D radiation pattern with the array element space $0.4(\lambda)$ . . . . .                        | 58 |
| Figure5.12 | 3D radiation pattern with the array element space $0.5(\lambda)$ . . . . .                        | 58 |
| Figure5.13 | radiation pattern in to two orthogonal plane variation at elevation angle= $(00^0)$               | 59 |
| FigureA.1  | Rectangular micro strip patch and its equivalent circuit transmission-line<br>model . . . . .     | 65 |

# Chapter 1

## Introduction

### 1.1 Background of the Study

Communication is the transfer of information from one point to another. The exchange of information today is not just between two points but multi points. As shown in Figure 1.1, the distance is unimaginable and also it covers area on this planet and even beyond. The process involves various steps and various important aspects are related to communication system. Antennas are one governing part of communication. An effective antenna means an effective

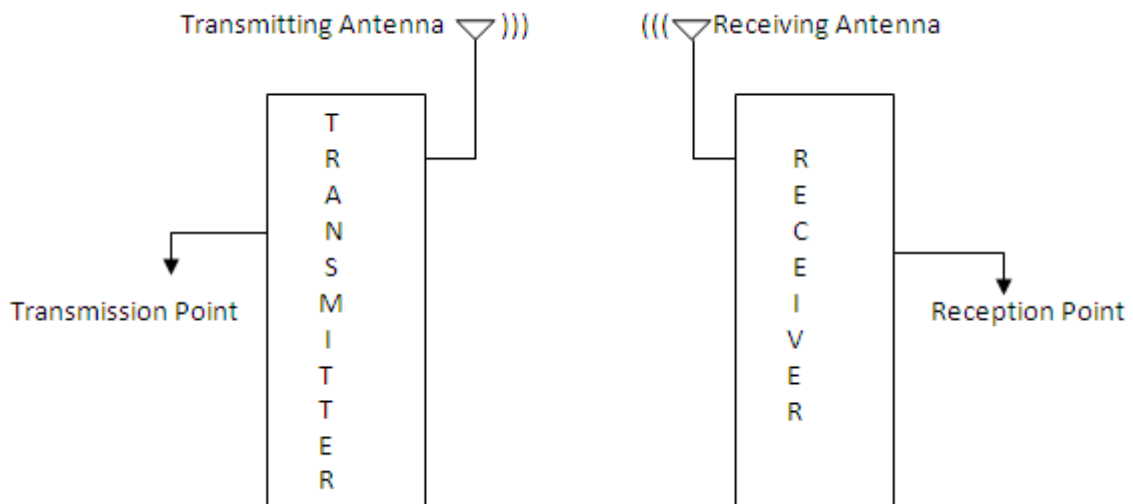

Figure 1.1: block diagram of communication system

communication. As show Figure 1.1, antennas are transitional structure between free space and a guiding device may be a transmission line. The size of the antennas even large sizes. However compact antennas are always a preferable design. It makes communication system non-bulky. Some of the common antennas that we see around are whip antennas on cars, single turn loop antennas for UHF television receiver, satellite parabolic reflector receiving antennas etc. Antennas are especially important in high performance communication systems like mobile communication, radar and navigation systems. Wireless communication is the fastest growing field of technology which has captured the attention of social life in the present century. Modern wireless local area networks are implemented in many homes, business centers

and campuses which focus many applications including wireless sensor networks, automated highways and factories. The cellular systems have experienced exponential growth over the last decade and there are currently around two billion users worldwide. The explosive growth of wireless systems coupled with the development of laptop and palmtop computers indicates a bright future for wireless networks, both as stand-alone systems and as part of the larger networking infrastructure. For the successful implementation of any wireless communication system, the antenna technology plays one of the important roles. An antenna is a device that transmits and/or receives electromagnetic waves. Most antennas are resonant devices, which operate efficiently over a relatively narrow frequency band. It must be tuned to the same frequency band that the radio system to which it is connected operates in, otherwise reception and/or transmission will be impaired. The receiving antenna as a part in the system is responsible of turning the electromagnetic waves into its original form (electrical signal in wire). The properties of the transmitting and receiving antennas are fully represented by Maxwell's equations. A good design of the antenna can reduce the system requirements and improve the overall system performance. Antenna serves as one of the critical component in any wireless communication system. In general, the antenna behaves as a transducer between guided wave and a free space [1]. Antennas are used to transmit and receive electromagnetic signals in wireless communication systems. From the view of a receiving antenna, the quality of the antenna depends upon how well it can receive the faintest electromagnetic waves. In general, antennas with very large aperture can detect faint signals much better than antennas with a comparatively smaller aperture. However, a larger aperture demands bulky systems and complex construction engineering which sometime exceeds the feasibility for physical implementation of the antenna. One way to overcome this challenge is to implement antenna array concepts where a number of identical antennas with very small apertures can be cascaded in different manners based on their functionality. The output of each small antenna is then combined to enhance the total received signal that is equivalent to the signal received with a single antenna with a large aperture. Mathematically, an antenna array can offer an aperture that exceeds the aperture of a single antenna and thus it can be capable of detecting extremely faint signals from far away sources. The compromised factor here is the complexity. Since the electromagnetic signal received by each antenna array element differs from the signals received by other array elements in terms of amplitude and phase, they must be combined coherently to achieve the desired output. Though it is more complex to set up an antenna array compared to a single antenna, weighting the signals before combining them enables enhanced performance features such as interference rejection and beam steering without physically moving the aperture. The

trade-off for these attractive features is increased complexity and cost.

## **1.2 Objective of the Study**

### **1.2.1 General objective of the study**

The main objectives of the thesis are:

- To design compact rectangular micro strip patches antenna for LTE applications.
- To get good background about the deployment of LTE and its requirements.

### **1.2.2 Specific objectives of the study**

The Specific objectives of the thesis are:

- A comparison of performance with the existing single micro strip patch array antenna
- Improve the performance of antenna parameters i.e. impedance matching, return loss and radiation pattern using MATLAB.

## **1.3 Motivation of the Thesis**

Now-a-days wireless systems are exploited in the domain of space communication, harvesting energy, tracking inventory and streaming entertainment to billions of people around the globe. The micro strip antenna is one of the most popular antennas used currently in wireless communications because of its simple geometry, ease of design, compactness, durability and low manufacturing cost. This type of antenna consists of a single conducting plane, usually made with copper, printed on the top layer of a dielectric material. A ground plane, also made with copper, is then printed on the bottom layer of the dielectric substrate. The radiation pattern of the antenna can be achieved by generating an electric field between the two conductor layers of the antenna by applying a voltage between the two conductors on the top and the bottom of the substrate. In the last few years, the trend of mobile phone technology has been dramatically decreasing the weight and size. Due to enhancement in this trend, the antenna used for mobile hand held devices have to be small, light-weighted, low profile and have an Omni-directional radiation pattern in horizontal plane. However, still there are challenges in the antenna's performance during interaction with the user's head and hand. The movement of the user during usage of mobile hand held devices often leads to gain, radiation pattern, high return loss and input impedance change. Therefore antennas used in hand held transceivers for personal communication have been recognized as crucial elements that can either improve or limit system performance. This is particularly true in terms of bandwidth and efficiency. Therefore, to

carefully design a handset with superior performance, engineers need to give attention to the design of the antenna systems of the mobile transceiver [2]. The modern wireless communication industry is advancing rapidly that all the communication systems are integrating many applications such as WLAN, Bluetooth etc. to the hand held devices [3]. In the near future, most of the wireless protocols will be employed in the mobile devices. Antenna isolation is very difficult problem to solve because of close proximity between antennas in space limited devices particularly in MIMO devices. Another challenge is small space available in most of the mobile devices. In order to overcome this challenge, we need multiband designs with consistent radiation pattern, easy integration with RF circuit, low profile, efficiency and polarization over the wide frequency band. Generally, most of the multiband antennas meet the return loss requirements, but the radiation performance is degrading at upper frequencies. Electronically tunable antennas are potential solution for few cases such as DVB-H. Antenna planning and placement is another challenge, which help to select and place the antenna efficiently in a system by considering both electrical and mechanical requirements. The modeling of the large antennas to predict its performance is another difficult task. One solution to design a micro strip patch array antenna on a non-planar surface is to print a uniformly linear array antenna on a semi flexible or flexible substrate capable of being mounted on a curved surface. Though several initial designs of linear antennas have been previously proposed, most of them are limited to operation only on a particular non-planar surface with a fixed and known curvature. Therefore if an antenna system can be developed to be operated under such conditions where the change of the curvature of the surface of the antenna array is acceptable during its operation, then the system will offer more flexibility in terms of using it on a non-planar surface with different and unknown curvatures. Thus, implementation of the conformal array concepts of printed micro strip antennas on a flexible substrate can be a solution to applications that require the antenna to be used on curved surfaces that change with time.

## 1.4 Methodology

This study involves four main procedures to achieve its objectives. The procedures involved simulations of the substrate parameter using MATLAB program. The following flow chart summarizes the procedures.

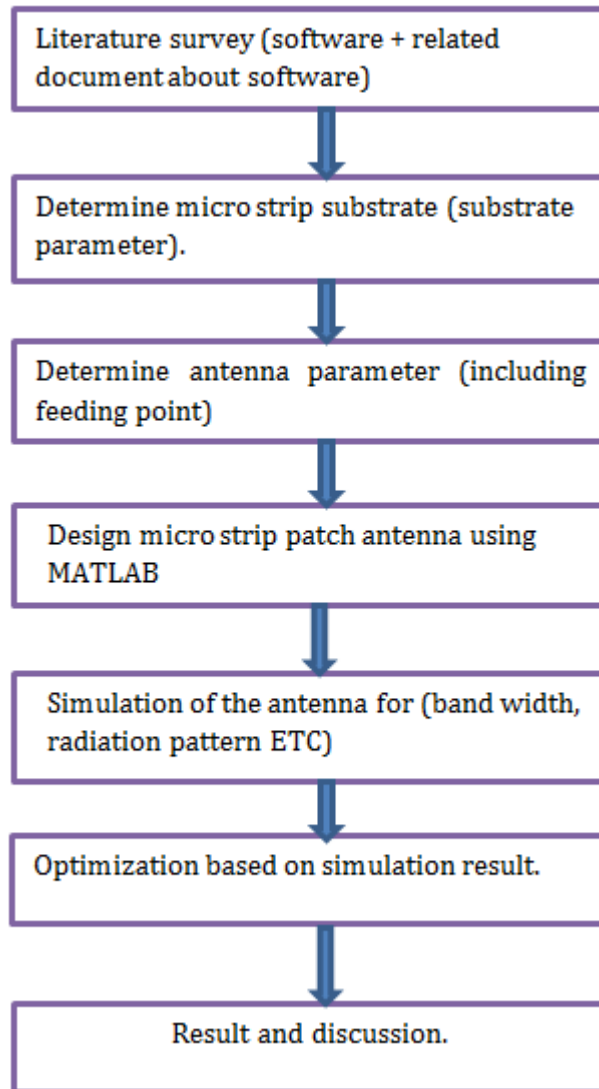

Figure 1.2: flow chart of methodology

### 1.4.1 Proposed Work

One of the drawbacks of an antenna array is the lack of ability to recover the original radiation pattern when it undergoes some sort of change in its physical structure. As illustrated in Figures 1.3 an antenna array has the capability of changing the direction of radiation by controlling the individual phases of the voltages being supplied to each micro strips antenna array, known as beam steering. To do that, design of feedback system of a planar conformal antenna array is being designed in this thesis. In particular, the feedback system will be used with suitable phase compensation to dynamically determine the changes in the curvature of the antenna surface and the circuit then modifies necessary input signals to each array element through a feedback path. The block diagram of the proposed setup has been shown in Fig. 1.3.

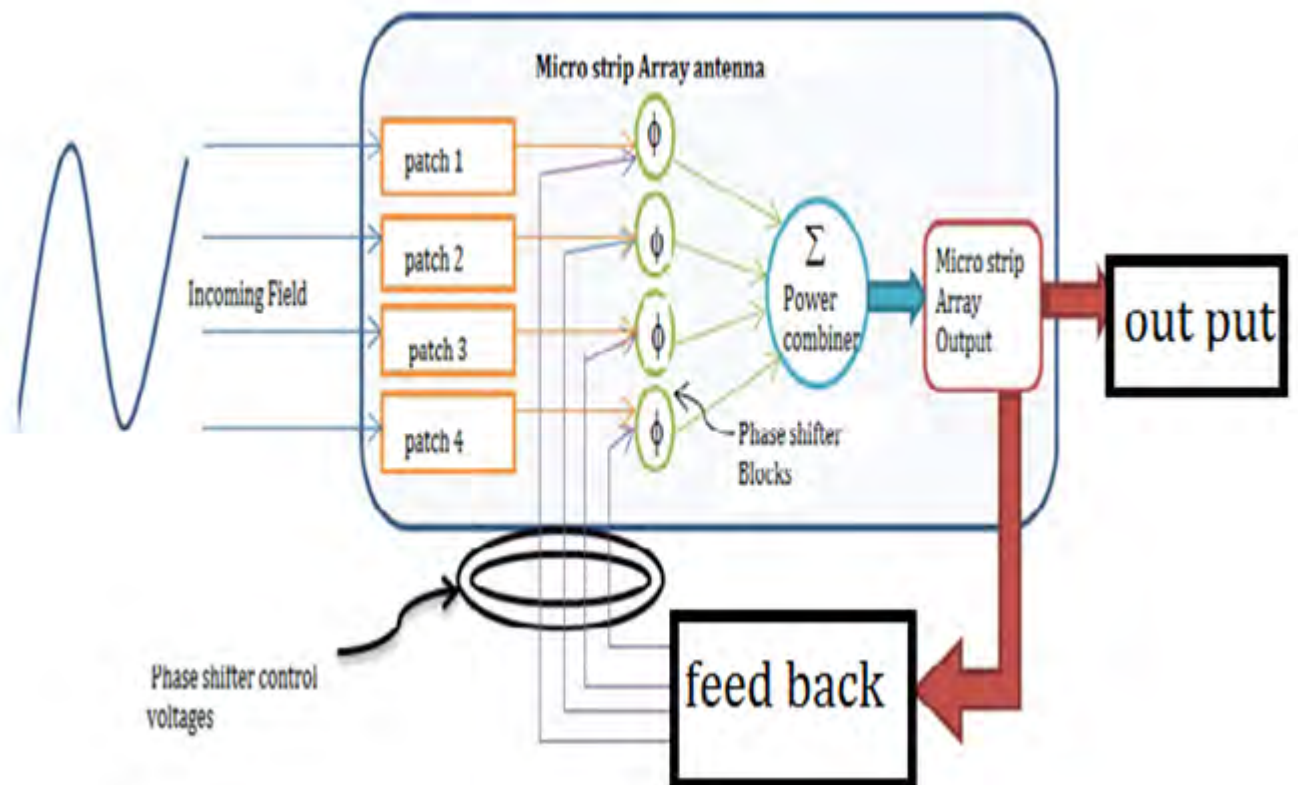

Figure 1.3: a generic block diagram of antenna system.

## 1.5 Literature Review

In [4] antenna is feed using micro strip feeding technique and simulated using IE3D software. The antenna shows single band bandwidth of 2 GHz for the working band of 4-6 GHz. The proposed antenna is useful for IEEE 802.11 WLAN standards in the 5.2/5.8 GHz band and WiMAX standards in the 5.5 GHz band.

In[5]defected ground plane is in the form of L shaped slot and the rectangular parasitic patches and diagonal cuts at top corners can increase the bandwidth. For the first and second resonant frequencies Return losses of -17dB and -30 dB respectively, can be achieved when the diagonal cut is at optimum value.

In [6] a rectangular micro strip patches antenna with DGS has been simulated using High Frequency Simulation Software (HFSS) at 2.45 GHz frequency, antenna is fed by Quarter Transformer feeding. The rectangular patch antenna designed with swastika shaped DGS structure,shows gain of 7dB. Patch antenna with Defected Ground Structure (DGS) demonstrate properties like improved returning loss, VSWR, bandwidth, gain of the antenna as compared to the conventional antenna.

In [7] a single frequency micro strips patch antenna feed using micro strip line fed and simulated using CST Microwave Studio software. Antenna operates at the frequency 5.2 GHz WLAN standard. Resultant impedance bandwidth is around 190 MHz with the having value of return loss as -47 dB has been obtained. The antenna also shows impedance of 50.89 ohm.

In [8] Series-Fed Micro strip Antenna Arrays and Their Application to Omni-Directional Antennas. The proposed antenna use cylindrical arrangement of six four-element arrays. Using this feeding mechanism, they have to conclude cylindrical arrangement is measured to have a gain of 6 dB over 750 MHz of bandwidth. A closed-form Omni directional pattern analysis is also developed.

In [9] circular patches antenna is designed with defect in ground plane.

In [10] antenna operating at 2.4 GHz frequency band for WLAN applications uses rectangular slot in the ground plane is located at different locations in the bottom of the substrate are considered and results of optimized patch antenna were obtained . Return loss improvement is from -17.72dB to -26.92dB. Gain improvement is from-5.1dB to -5.9 dB.

According to [11] the substrate material plays significant role determining the size and bandwidth of an antenna. Increasing the dielectric constant decreases the size but lowers the bandwidth and efficiency of the antenna while decreasing the dielectric constant increases the bandwidth but with an increase in size.

In [12] antenna Simulated At 4.30 GHz frequency and it is proved that when defect is intro-

duced in ground plane of the single band antenna then the resulting antenna has its resonant frequency at lower side that is at 2.5GHz , which shows that the antenna has compact in size and improvement in gain and bandwidth. Here multi band operation of antenna is also obtained.

In [13] very compact antenna was designed, the antenna for WLAN operating in band of 2.4 and 5GHz. Various results are obtained by varying different dimensions of patch. Antenna is feed using micro strip feed. Different defected ground structures (DGS) have been developed analyzed.

In [14] and it is concluded that although the DGS has applications in the field of the, microwave oscillators, microwave filter design, microwave couplers to increase the coupling, microwave amplifiers, etc., it can be used in the micro strip antenna design for various advantages such as antenna size reduction mutual coupling reduction, harmonic suppression, cross polarization reduction, in antenna arrays etc.

In [15] micro strip patches antenna for GSM and WiMax application was proposed. The proposed antenna shows promising characteristics for WLAN, WiMax, and Satellite application at resonant frequencies of 5.5 GHz for WiMAX, 5.2 GHz and 5.8 GHz for WLAN and 6-7 GHz for satellite application respectively.

In [16] Mutual Coupling Calibration for Micro strip Antenna Arrays via Element Pattern Reconstruction Method The proposed antenna shows Calibrate the mutual coupling effect of the micro strip arrays approach and deduce Wide adaptability for element structures and is very effective for the micro strip antenna array.

In [17] A Compact Frequency- Reconfigurable Narrow band Micro strips Slot Antenna. The proposed antennas shows Frequency Reconfigurable micro strip slot antenna approach and minimize the parasitic effects toward the performance of the antenna.

In [18] A New Compact Aperture- Coupled Micro strip Antenna with Corrugated Ground Plane. The proposed antenna presented Aperture-coupled micro strip antenna with enhanced gain and radiation pattern. Gain is increased by 5.3 dB, the front-to-back ratio (F/B) is increased by 6dB, and (HPBW) of E plane is reduced by  $125^\circ$ .

In [19] Series-Fed Micro strip Antenna Array with Inclined-Slot Couplers as Three-Way Power Dividers. The proposed antenna Modified three-way slot power divider is applied and proposed modifications reduce dissipation losses

This thesis is improve the radiation pattern and the return loss without degrading the band width efficiency of the patch antenna. to achieve this a 4x1 corporate (parallel) fed rectangular Micro strip patches array antenna with micro strip feed line is designed.

## **1.6 Organization of the Thesis**

This thesis is organized into five chapters. Chapter 1 presents the introductory part of the thesis by describing an overview of antenna, the motivation of the work, the methodology of the thesis and the literature review are included in this introductory chapter.

Chapter 2 provides review of long term evolution (LTE) with its antenna design challenge. Chapter 3 covers the theoretical background of micro strip patch and its feeding technique. In this Chapter Array Antennas are explain especially micro strip patch array antennas. In chapter 4, Design of Rectangular Micro strip Patch Array Antenna is presented. The result and discussion of this Thesis is discusses in chapter 5.

Finally conclusion and recommendation for future work is discussed in chapter 6.

# Chapter 2

## Review of Long Term Evolution Mobile Technology

### 2.1 LTE Overview and Target System Requirements

The Long Term Evolution (LTE) is the standard name given to the mobile technology project of the 3rd Generation Partnership Project (3GPP) to meet up with the set requirements for present and future needs of mobile communications. The 3GPP LTE project started in 2004. The introduction of the LTE is aimed at enhancing the Universal Terrestrial Radio Access Network (UTRAN). Its evolution is aimed towards achieving the fourth generation (4G) mobile technologies. An LTE antenna is designed for use in a mobile phone, using a dual-port configuration. The antenna is also optimized for minimal reflection coefficient at both ports and cross coupling between the ports as low as possible. It provides a comprehensive and secure all IP based mobile broadband solution to all kinds of mobile communication devices. WiMAX, HSPA+ and first-release Long Term Evolution (LTE) have been the dominant technologies in this market. These technologies have been designed for channel bandwidths of 5 to 20 MHz (optionally up to 40 MHz) and offer peak data rates of 100 MBit/s for high mobility devices and 1 Gbps for low mobility devices. Table 2.1 shows a progression towards the 4G technology based on the UMTS specifications evolution [20]. Under the new LTE system which was to

Table 2.1: Evolution of UMTS specification

| Release | Main Radio Features of the Release.   |
|---------|---|
| Rel-99  | UMTS 3.84 Mcps, WCDMA FDD and TDD.  |
| Rel-4   | 1.28 Mcps TDD, also known TD-SCDMA.   |
| Rel-5   | HSDPA   |
| Rel-6   | HSUPA (E-DCH).  |
| Rel-7   | HSPA+ (64QAM DL, MIMO, 16QAM UL), LTE and SAE feasibility study EDGE Evolution.                         |
| Rel-8   | LTE work item - OFDMA air interface, SAE work, new IP core network, 3G femto cells, dual carrier HSDPA. |
| Rel-9   | Multi-standard radio (MSR) dual cell HSUPA, LTE-Advanced Feasibility study, SON, LTE femto cells.       |
| Rel-10  | LTE-Advanced (4G) work item, CoMP study, four HSDPA.  |

evolve around the 3GPP radio access technology over period of time, some target summaries were made in order to give summarized targets and requirements for the LTE release 8, some

of these are:

- Reduced delays, particularly on latency;
- Considerable increase in user data rates;
- Increased in cell edge bit rate, most especially for even provision of services;
- Decrease in cost per bit, which helps to improve spectral efficiency;
- Absolute increase in flexibility for spectrum use;
- A better and simpler network architecture;
- Ease of access in terms of mobility; and most importantly
- Power consumption reduction for user equipment.

In more technical perspective, some of the LTE requirement targets are itemized below:

1. The need for support for scalable or flexible frequency in bandwidths of 1.25, 2.5, 5.0, 10.0 and 20.0 MHz
2. Initial peak data rate scaled with system bandwidth for Down link (DL) for 2 RX Channel MIMO at peak rate of 100 Mbps in 20 MHz channel and for Up link (UL) for single Channel TX at peak rate of 50 Mbps in 20 MHz channel.
3. Use of scheduling algorithms and supported advanced multi-antenna configurations which improves data rates, with DL - 4 x 2, 2 x 2, 1 x2 and 1 x1 and with UL - 1 x2 and 1 x1.
4. Spectrum efficiency - DL 3 to 4 xHSDPA Release 6 and UL 2 to 3 xHSUPA Release 6.
5. Latency - For Control plane (C-plane), less than 50 - 100 ms to establish User plane (U plane) and for U-plane less than 10 ms from UE to server. In addition, one way latency of below 5 ms which enables 10 ms Round Trip Times (RTT).
6. In terms of Mobility, supports optimized for low speeds (< 15 km/hr); high performance for speeds up to 120 km/hr; and maintained link for speeds up to 350 km/hr (and targeted speeds of up to 500 km/hr with frequency band consideration).
7. In addition, a coverage radius of full performance up to 5 km; a slight degradation 5 km - 30 km and supports for operation up to 100 km should not be precluded by standard.

The overall LTE system requirements are based on System Capability (Peak Data Rates and Latency); System Performance (Throughput, Spectrum efficiency, Mobility, Coverage and Enhanced Multimedia Broadcast/Multi-cast Services, eMBMS); System Spectrum Allocation; System Architecture and Cost Reductions.

## 2.2 Performance Goals for LTE

E-UTRA is expected to support different types of services including web browsing, FTP (File Transfer Protocol), video streaming, VoIP (Voice over Internet Protocol), online gaming, real time video, push-to-talk and push-to-view. Therefore, LTE is being designed to be a high data rate and low latency system as indicated by the key performance criteria shown in Table 2.2. The bandwidth capability of a UE is expected to be up to 20 MHz for both transmission and reception. The service provider can however deploy cells with any of the bandwidths listed in Table 2.2. This gives flexibility to service providers to tailor their offering dependent on the amount of available spectrum or the ability to start with limited spectrum for lower upfront cost and grow the spectrum for extra capacity [21]. LTE has an instantaneous down link peak

Table 2.2: LTE performance requirements.

| Metrics   | Requirements   |
|---|--|
| Peak Data Rate  | DL: 100Mbps,UL: 50Mbps (For 20MHz Spectrum)                      |
| Mobility  | Support Up to 500Kmph but optimized for low speeds from 0-15kmph |
| Control Plane Latency (Transition Time to Active State) | <100ms (For Idle to Active)                                      |
| User Plane Latency                                      | <5ms   |
| Control Plane Capacity                                  | >200 users per cell (For 5MHz spectrum)                          |
| Coverage (Cell Size)                                    | 5-100Km with slight degradation after 30Km                       |
| Spectrum Flexibility                                    | 1.25, 2.5, 5, 10, 15 and 20 MHz                                  |

data rate (DL) of 100 Mbps within a 20 MHz down link spectrum allocation (5 bps/Hz) and an instantaneous up link peak data rate (UL) of 50 Mb/s (2.5 bps/Hz) within a 20 MHz up link spectrum allocation. The Control plane latency has a transition time of less than 100 ms from a camped state to an active state and less than 50 ms from a dormant state and an active state. The control plane capacity is at least 200 users per cell and is supported in the active state for spectrum allocations up to 5 MHz the user plane latency is of less than 5ms in unloading condition (i.e. single user with single data stream) for small IP packet. The down link average user throughput per MHz for 4G networks is 3 to 4 times larger and the up link average user throughput per MHz is 2 to 3 times larger as compared to 3G networks. The target for spectrum efficiency of down link in a loaded network is 3 to 4 times larger and for up link it is 2 to 3 times larger. E-UTRAN should be optimized for low mobile speed from 0 to 15 km/h. The

higher mobile speed between 15 and 120 km/h should be supported with high performance and mobility across the cellular network shall be maintained at speeds from 120 km/h to 350 km/h (or even up to 500 km/h depending on the frequency band). Throughput, spectrum efficiency and mobility targets above should be met for 5 km cells, and with a slight degradation for 30 km cells and the cells in a range up to 100 km should not be precluded.

## **2.3 Antenna Design Challenges for 4G/LTE Handsets**

Challenges that typically influence the design of an LTE antenna for a mobile device are:

- Minimal antenna size and tight integration with other device components.
- Mutual coupling between different antennas have to be minimized.
- Compliance with radiation hazard restrictions has to be maintained.
- Thickness 1cm (slim phones 0.5cm)
- Width 6cm
- Length 12cm
- Antenna Size.
- Mutual Coupling.
- In-Suite Performance.
- Compliance with SAR Regulation.
- Channel Capacity Improvements.

## **2.4 Major requirements for LTE**

LTE defines a new high speed access method for mobile communication systems. Flexibility and interoperability with current technology are combined with the following features,

- Peak data rates of 100 Mbps for down link and 50 Mbps for the up link.
- Improved spectrum efficiency.
- The system transmits and receives at the same time using full duplex.

# Chapter 3

## Micro strip Patches Antenna

### 3.1 Introduction

Micro strip patches antenna is used in a wide range of applications because it is easy to design and fabricate. The antenna is attractive due to its low-profile conformal design, relatively low cost, and very narrow bandwidth. This model uses an inset feeding strategy that does not need any additional matching parts. For applications where size, weight, cost, performance, ease of installation and aerodynamics are constraints, low profile antennas are needed. Aircraft, spacecraft, satellite and missile applications and recently mobile radio and wireless communications demands [1]. To meet these requirements micro strip antennas can be used. These antennas are low profile, suited to planar and non-planar surfaces, simple and inexpensive to manufacture, mechanically robust when mounted on rigid surfaces, compatible with MMIC designs, and when the particular patch shape and mode are selected, they are very versatile in terms of resonant frequency, polarization, pattern and impedance [1]. In addition, by adding loads between the patch and the ground plane, such as pins and varactor diodes, adaptive elements with variable resonant frequency, impedance, polarization, and pattern can be designed. A micro strip antenna in its simplest configuration consists of a radiating patch on one side of a dielectric substrate, which has a ground plane on the other side. The patch conductors usually made of copper or gold can be virtually assumed to be of any shape. However, conventional shapes are normally used to simplify analysis and performance prediction. The radiating elements and the feed lines are usually photo etched on the dielectric substrate. Major operational disadvantages of micro strip antennas are their low efficiency, low power, high Q, poor polarization purity, poor scan performance, spurious feed radiation and narrow frequency bandwidth which are typically only a fraction of a percent or at most, a few percent [1]. Micro strip antennas also exhibit large electromagnetic signatures at certain frequencies outside the operating band and are rather large physically at VHF and possibly UHF frequencies. In large arrays there is a trade-off between bandwidth and scan volume [1].

## **3.2 Advantages and Disadvantages**

### **3.2.1 Advantages of micro strip antennas**

- It is light in weight and low profile.
- It can be made conformal to the host surface.
- Their ease of mass production using printed circuit technology leads to a low fabrication cost.
- It is easier to integrate with other micro strip circuits.
- It supports both linear polarization and circular polarization.
- It can be realized in a very compact form, desirable for personal and mobile communication hand held devices.
- It allow for dual and triple band operations

### **3.2.2 Disadvantages of micro strip antennas.**

- Narrow bandwidth
- Lower power gain
- Lower power handling capability
- Polarization impurity
- Surface wave

## **3.3 Antenna Array and Feed Techniques**

An antenna array (often called a 'phased array') is a set of two or more antennas. The signals from the antennas are combined or processed in order to achieve improved performance over that of a single antenna. The antenna array can be used to:

- increase the overall gain
- provide diversity reception
- cancel out interference from a particular set of directions
- "steer" the array so that it is most sensitive in a particular direction

- determine the direction of arrival of the incoming signal
- To maximize the Signal to Interference plus Noise Ratio (SINR).

Array means a collection of similar entities or set of individual antenna elements connected together to behave as a single unit. Advantages

- Higher Gain
- Beam Steering Capability
- Reliable
- Higher SNR

Usually the radiation pattern of a single element is relatively wide, and each element provides low values of directivity (gain). In many applications, it is necessary to design antennas with very high directive characteristics (very high gain) to meet the demands of long distance communication. This can only be accomplished by increasing the electrical size of the antenna. Enlarging the dimensions of single elements often leads to more directive characteristics. Another way to enlarge the dimensions of the antenna, without increasing the size of individual element, is to form an assembly of radiating elements in an electrical and geometrical configuration. This new antenna formed is referred to as an array [1]. The antenna arrays are of vast importance and are widely used nowadays for various purposes like military, missiles and satellite communication. There are different forms of antenna arrays linear, circular, planar etc. The radiation pattern of an array antenna is mostly considered in the far field, where the field depends on two parameters. One is the distance of the receiver and the other deals with the spherical coordinate's  $\theta$  and  $\phi$ . The radiation pattern of an antenna can be calculated by:

$$\text{arraypattern} = \text{arrayelementpattern} * \text{arrayfactor}(AF)$$

The array factor determines the overall radiation pattern of the array while the element pattern describes radiation pattern of the individual element. The array factor can also be defined as "The function of the total number of elements, their spacing and the phase difference between each element" [3]. Arrays are very versatile and are used, among other things, to synthesize a required pattern that cannot be achieved with a single element. In addition, they are used to scan the beam of an antenna system, increase directivity, and perform various other functions which would be difficult with any one single element. The elements can be fed by a single line called the series-feed network or by multiple lines called corporate-feed network. Among all the feeding techniques, corporate feed is mostly used in scanning, phased multiple

beam or shaped beam arrays. With this method, the designer has more control of the feed of each element (amplitude and phase) and it is ideal for scanning phased arrays, multiple beam arrays, or shaped-beam arrays [1]. While designing an array, the feed point and the distance between each patch is kept constant in order to provide equal phase patch excitation. A series feed network is easy to fabricate and implement as compared to corporate feed network. The disadvantage of using series feed is that it gives phase delay and hence it is not preferred for the phase scanning arrays. These phase shifts are frequency dependent due to which beam scanning is dependent on the frequency. Corporate feed networks provide flexible phase control of each array element. It is suitable for phase scanning as it is less affected by the frequency scan. The most common form of corporate feed network is the Wilkinson Power divider rule [3]. There are four different feeding techniques.

1. Micro strip line Feed
2. Coaxial feed
3. Aperture coupling
4. Proximity Coupled

### **3.3.1 Micro strip Line Feed**

The micro strip feed line is a conducting strip that is simple to fabricate and easy to impedance match by adjusting the inset position of the patch. The width of the micro strip feed line is much smaller than the width of the patch. However, the drawback of this feeding technique is that the surface wave and feed line radiation increases as the thickness of the substrate increases, therefore the bandwidth of the antenna is limited. The micro strip feed line techniques are used extensively in planar transmission lines and microwave and millimeter wave circuitry. The purpose of the inset cut in the patch is to match the impedance of the feed line to the patch without the need for any additional matching element. This is achieved by properly controlling the inset position. Hence this is an easy feeding scheme, since it provides ease of fabrication and simplicity in modeling as well as impedance matching. However as the thickness of the dielectric substrate being used, increases, surface waves and spurious feed radiation also increases, which hampers the bandwidth of the antenna [5]. The feed radiation also leads to undesired cross polarized radiation. As show in the Figure 3.2, the inputs connect with the radiating element, which is the patch through micro strip line.

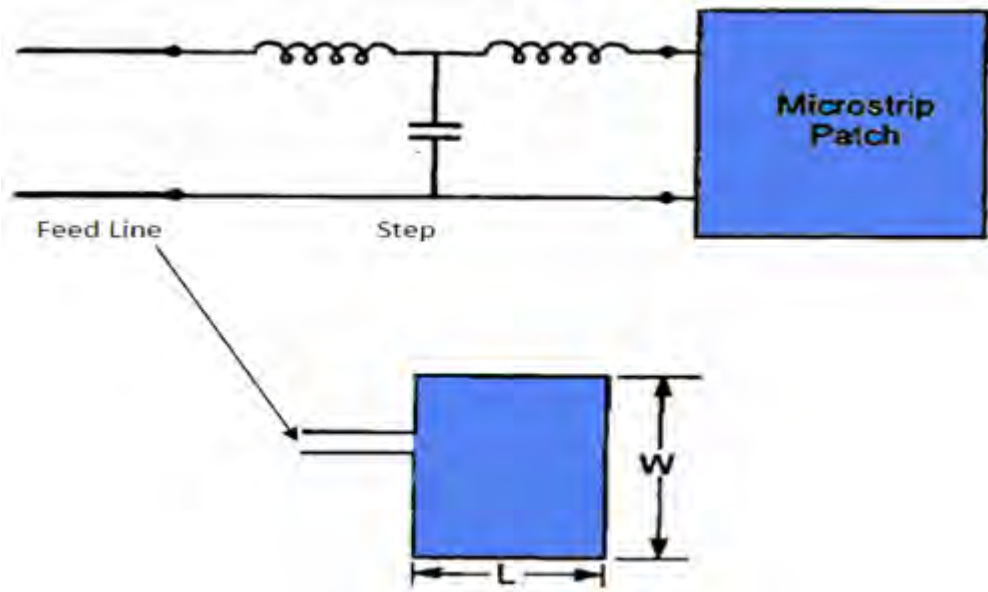

Figure 3.1: A Micro strip feed and the equivalent circuit, Micro strip feed at a radiating edge[5]

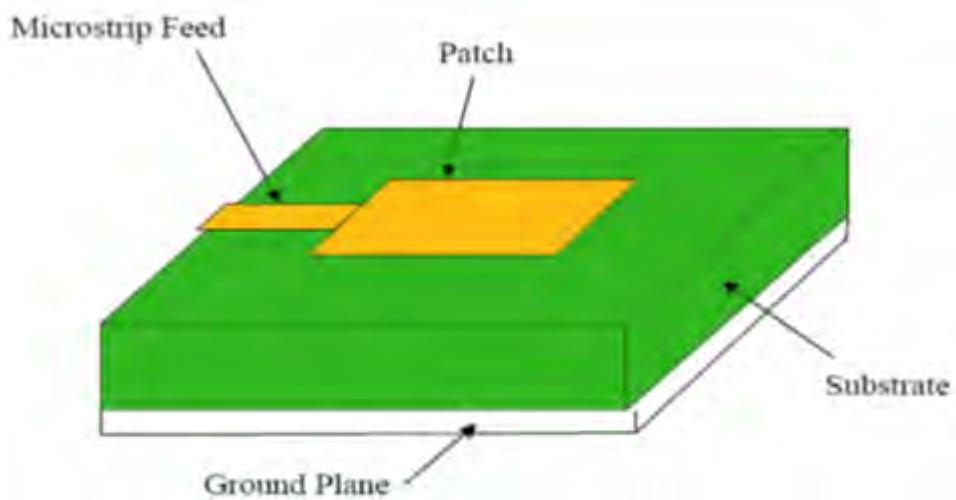

Figure 3.2: Micro strip Line Feed[5]

### 3.3.2 Coaxial Feed

The Coaxial feed or probe feed is a very common technique used for feeding Micro strip patch antennas. As seen from Figure 3.3, the inner conductor of the coaxial connector extends through the dielectric and is soldered to the radiating patch, while the outer conductor is connected to the ground plane [5]. The main advantage of this type of feeding scheme is that the feed can

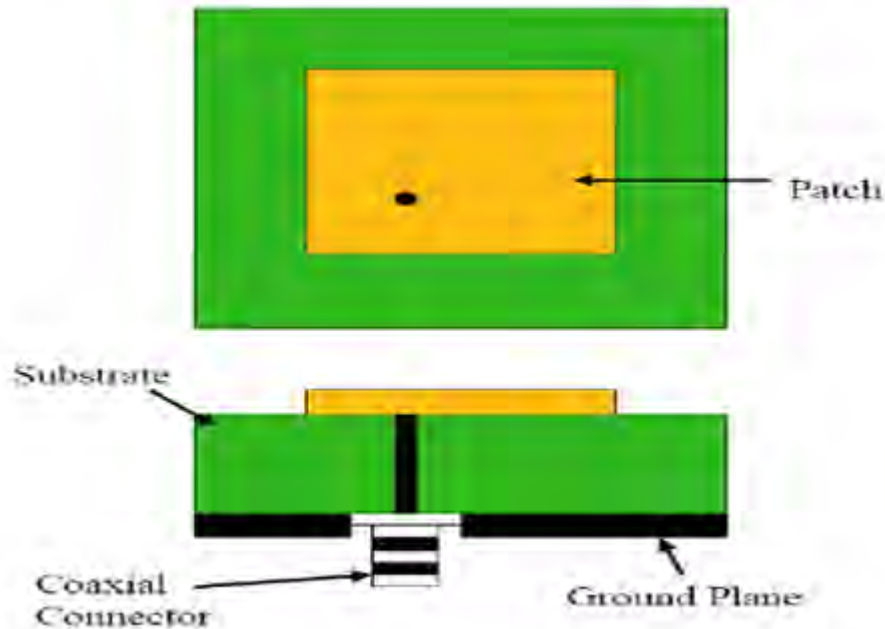

Figure 3.3: Probe fed Rectangular Micro strip Patch Antenna[5]

be placed at any desired location inside the patch in order to match with its input impedance. This feed method is easy to fabricate and has low spurious radiation. However, a major disadvantage is that it provides narrow bandwidth and is difficult to model since a hole has to be drilled in the substrate and the connector protrudes outside the ground plane, thus not making it completely planar for thick substrates ( $h > 0.02\lambda$ ). Also, for thicker substrates, the increased probe length makes the input impedance more inductive, leading to matching problems [9]. It is seen above that for a thick dielectric substrate, which provides broad bandwidth, the micro strip line feed and the coaxial feed suffer from numerous disadvantages. The non-contacting feed techniques which have been discussed below, solve these issues.

### 3.3.3 Aperture Coupled Feed

In this type of feed technique, the radiating patch and the micro strip feed line are separated by the ground plane as shown in Figure 3.4. Coupling between the patch and the feed line is made through a slot or an aperture in the ground plane. The coupling aperture is usually centered under the patch, leading to lower cross-polarization due to symmetry of the configuration.

The amount of coupling from the feed line to the patch is determined by the shape, size and location of the aperture. Since the ground plane separates the patch and the feed line, spurious radiation is minimized. Generally, a high dielectric material is used for bottom substrate and a thick, low dielectric constant material is used for the top substrate to optimize radiation from the patch [5]. The major disadvantage of this feed technique is that it is difficult to fabricate due to multiple layers, which also increases the antenna thickness. This feeding scheme also provides narrow bandwidth.

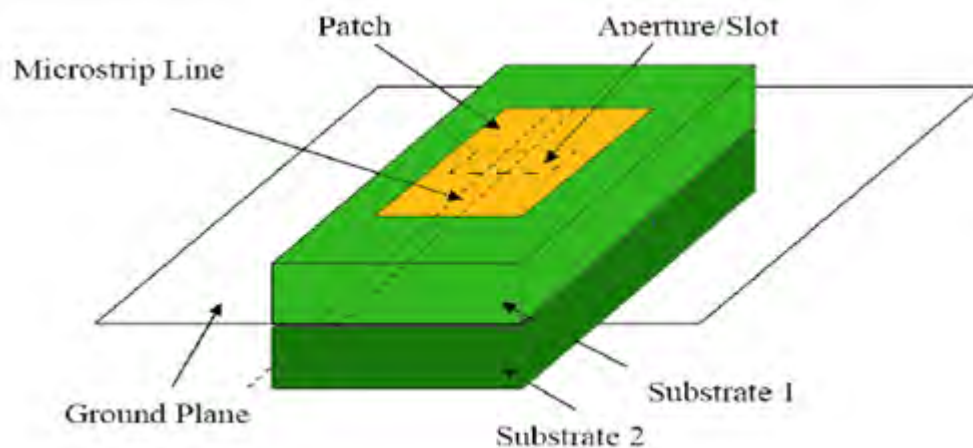

Figure 3.4: Aperture-coupled feed[5]

### 3.3.4 Proximity Coupled Feed

This type of feed technique is also called as the electromagnetic coupling scheme. As shown in Figure 3.5, two dielectric substrates are used such that the feed line is between the two substrates and the radiating patch is on top of the upper substrate. The main advantage of this feed technique is that it eliminates spurious feed radiation and provides very high bandwidth (as high as 13%) due to overall increase in the thickness of the micro strip patch antenna. This scheme also provides choices between two different dielectric media, one for the patch and one for the feed line to optimize the individual performances [5]. Matching can be achieved by controlling the length of the feed line and the width-to-line ratio of the patch. The major disadvantage of this feed scheme is that it is difficult to fabricate because of the two dielectric layers which need proper alignment. Also, there is an increase in the overall thickness of the antenna.

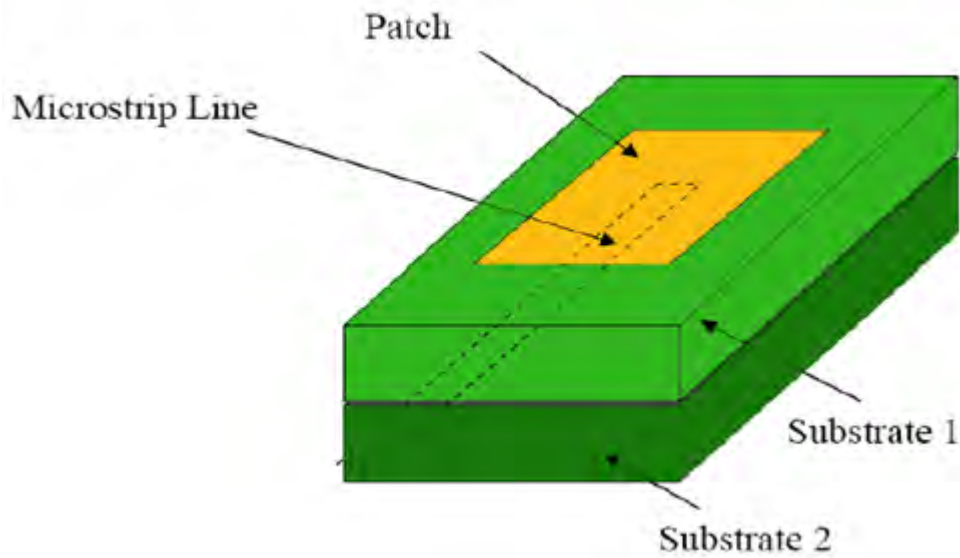

Figure 3.5: Proximity-coupled Feed [5]

Table 3.1: summarizes the advantages and disadvantages of the four feeding methods [14]

|   |  |
|---|--|
| <b>Advantages Micro strip Line</b>  | Disadvantages Micro strip Line   |
| <ul style="list-style-type: none"> <li>⇒ <i>Monolithic</i></li> <li>⇒ <i>Easy to fabricate</i></li> <li>⇒ <i>Easy to match by controlling Insert position</i></li> <li>⇒ <i>Easy to match</i></li> </ul>                              | <ul style="list-style-type: none"> <li>⇒ <i>Spurious radiation from feed line especially for thick substrate when line width is significant</i></li> </ul> |
| <b>Advantages Coaxial Feed</b>  | Disadvantages Coaxial Feed   |
| <ul style="list-style-type: none"> <li>⇒ <i>Low spurious radiation</i></li> <li>⇒ <i>Easy to match</i></li> </ul>   | <ul style="list-style-type: none"> <li>⇒ <i>Soldering required substrate</i></li> <li>⇒ <i>Large inductance for thick substrate</i></li> </ul>             |
| <b>Advantages Aperture Coupled</b>  | Disadvantages Aperture Coupled   |
| <ul style="list-style-type: none"> <li>⇒ <i>Use of two substrates avoids deleterious effect</i></li> <li>⇒ <i>No direct contact between feed and patch</i></li> <li>⇒ <i>No radiation from the feed and active devices</i></li> </ul> | <ul style="list-style-type: none"> <li>⇒ <i>Multilayer fabrication required</i></li> <li>⇒ <i>Higher back lobe radiation</i></li> </ul>                    |
| <b>Advantages Aperture Coupled</b>  | Disadvantages Aperture Coupled   |
| <ul style="list-style-type: none"> <li>⇒ <i>No direct contact between feed and patch.</i></li> <li>⇒ <i>large effective thickness for patch substrate</i></li> </ul>  | <ul style="list-style-type: none"> <li>⇒ <i>Multilayer fabrication required.</i></li> </ul>  |

### 3.4 Methods of analysis of Micro strip Patch Antenna

The most popular methods for the analysis of micro strip patch antennas are the transmission line model, cavity model and full wave model (which include primarily integral equations (moment method)). The transmission line model is the simplest of all and it gives good physical insight but it is less accurate. The cavity model is more accurate and gives good physical insight but is complex in nature. The full wave models are extremely accurate, versatile and can treat single elements, finite and infinite arrays, stacked elements, arbitrary shaped elements and coupling.

#### 3.4.1 Transmission Line Model Analysis for a Rectangular Patch

This model represents the micro strip antenna by two slots of width ' $w$ ' and height ' $h$ ', separated by transmission line of length ' $L$ '. The micro strip is essentially a non homogeneous line of two dielectrics typically substrate and air. As seen from the Fig 3.6, most of the electric field lines lie in the substrate and parts of some lines in air. As a result, this transmission line cannot support pure transverse electric-magnetic ( $TEM$ ) mode of transmission, since phase velocities would be different in the air and the substrate. Instead, the dominant mode of propagation would be the quasi- $TEM$  mode [7]. Hence an effective dielectric constant ( $\epsilon_e$ ) must be obtained in order to account for the fringing and the wave propagation in the line. The value of ( $\epsilon_e$ ) is slightly less than  $\epsilon_r$  because the fringing fields around the periphery of the patch are not confined in the dielectric substrate but are also spread in the air. The expression for ( $\epsilon_e$ ) is given by:

$$\epsilon_e = \frac{\epsilon_r + 1}{2} + \frac{\epsilon_r - 1}{2} \left[ 1 + \frac{12h}{w} \right]^{-1/2} \quad (3.1)$$

Where

$\epsilon_r$  = relative dielectric constant.

$\epsilon_e$  = effective dielectric constant

$h$  = dielectric thickness (mm)

$w$  = Width of the patch

#### Fringing Effects

Because the dimensions of the patch are finite along the length and width, the fields at the edges of the patch undergo fringing. This is illustrated along the length in Figures 3.7(a, b) for the two radiating slots of the micro strip antenna. The same applies along the width. The amount of fringing is a function of the dimensions of the patch and the height of the substrate. For the principal E-plane (xy-plane) fringing is a function of the ratio of the length of the patch

L to the height h of the substrate ( $L/h$ ) and the dielectric constant  $\epsilon_r$  of the substrate. Since for micro strip antennas  $L/h \gg 1$ , fringing is reduced; however, it must be taken into account

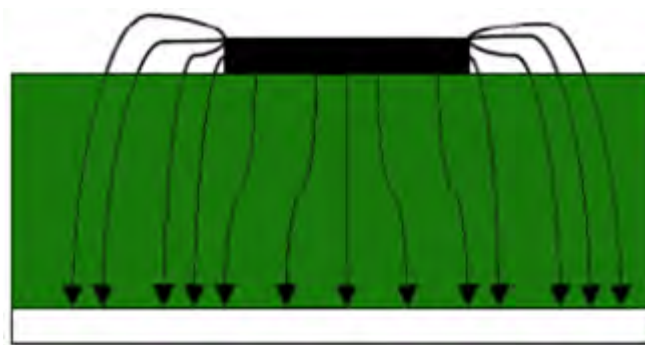

Figure 3.6: Electric Field Lines[1]

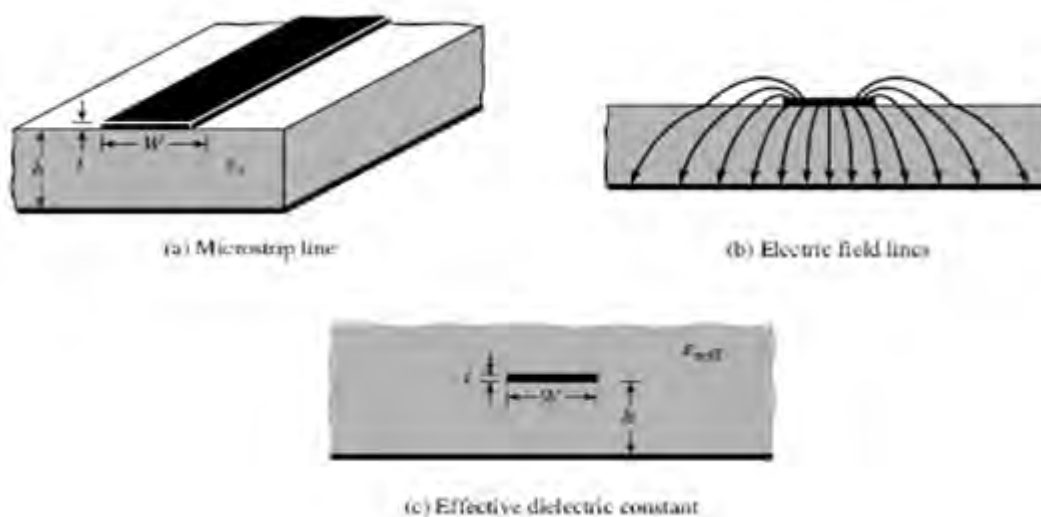

Figure 3.7: Micro strip line and its electric field lines, and effective dielectric constant[1]

because it influences the resonant frequency of the antenna. The same applies for the width. For a micro strip line shown in Figure 3.7(a), typical electric field lines are shown in Figure 3.7(b). This is a non homogeneous line of two dielectrics; typically the substrate and air. As can be seen, most of the electric field lines reside in the substrate and parts of some lines exist in air. As  $W/h \gg 1$  and  $\epsilon_r \gg 1$ , the electric field lines concentrate mostly in the substrate. Fringing in this case makes the micro strip line look wider electrically compared to its physical dimensions. Since some of the waves travel in the substrate and some in air, an effective dielectric constant  $\epsilon_e$  is introduced to account for fringing and the wave propagation in the line [1]. The effective dielectric constant is defined as the dielectric constant of the uniform dielectric material so that the line of Figure 3.7 (c) has identical electrical characteristics, particularly propagation constant, as the actual line of Figure 3.7(a).

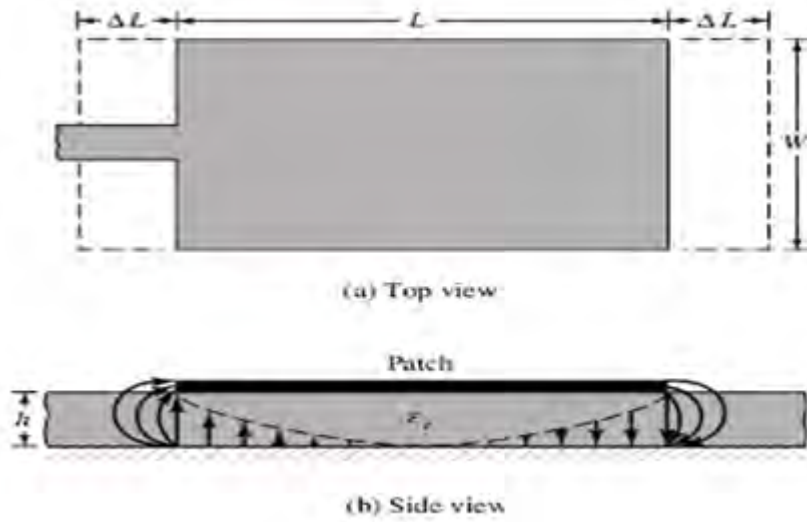

Figure 3.8: Physical and effective lengths of rectangular micro strip patch

### Effective Length, Resonant Frequency, and Effective Width

Because of the fringing effects, electrically the patch of the micro strip antenna looks greater than its physical dimensions. For the principal E-plane (xy plane), this is demonstrated in Figure 3.8 (a) where the dimensions of the patch along its length have been extended on each end by a distance  $\Delta L$ , which is a function of the effective dielectric constant  $\epsilon_e$  and the width-to-height ratio ( $w/h$ ) [1]. Since the length of the patch has been extended by  $\Delta L$  on each side, the effective length of the patch is now  $(L = \lambda/2)$  for for dominant  $TM_{010}$  mode with no fringing

$$L_{eff} = L + 2\Delta \quad (3.2)$$

For the dominant  $TM_{010}$  mode, the resonant frequency of the micro strip antenna is a function of its length. Usually given by

$$(f_r)_{010} = \frac{1}{2L\sqrt{\epsilon_r\mu_0\epsilon_0}} = \frac{V_0}{2L\sqrt{\epsilon_r}} \quad (3.3)$$

Where  $V_0$  is the speed of light in free-space. Since (3-3) does not account for fringing, it must be modified to include edge effects and should be computed using Where

$$(f_{re})_{010} = \frac{1}{2L_{eff}\sqrt{\epsilon_{reff}\mu_0\epsilon_0}} = \frac{1}{2(L+2\Delta L)\sqrt{\epsilon_r\epsilon_{eff}\mu_0\epsilon_0}} = q \frac{1}{2L\sqrt{\epsilon_r\mu_0\epsilon_0}} = \frac{V_0}{2L\sqrt{\epsilon_r}} \quad (3.4)$$

where

$$q = \frac{(f_{re})_{010}}{(f_r)_{010}} \quad (3.5)$$

The  $q$  factor is referred to as the fringe factor (length reduction factor). As the substrate height increases, fringing also increases and leads to larger separation between the radiating edges and lower resonant frequencies [1]

### 3.4.2 Cavity Mode

In the cavity model, the region between the patch and the ground plane is treated as a cavity that is surrounded by magnetic walls round the periphery and by electric walls from the top and bottom sides. Since thin substrates are used, the field inside the cavity is uniform along the thickness of the substrate. The fields underneath the patch for regular shapes such as rectangular, circular, triangular, and sectorial can be expressed as a summation of the various resonant modes of the two-dimensional resonator. The fringing fields around the periphery are taken care of by extending the patch boundary outward so that the effective dimensions are larger than the physical dimensions of the patch. The effect of the radiation from the antenna and the conductor loss are accounted for by adding these losses to the loss tangent of the dielectric substrate. The far field and radiated power are computed from the equivalent magnetic current around the periphery [8]. An alternate way of incorporating the radiation effect in the cavity model is by introducing an impedance boundary condition at the walls of the cavity. The fringing fields and the radiated power are not included inside the cavity but are localized at the edges of the cavity. However, the solution for the far field, with admittance walls is difficult to evaluate.

## 3.5 Overview of the Antenna Parameters

### 3.5.1 Basic Principles of Operation

The figure 3.9 shows a patch antenna in its basic form: a flat plate over a ground plane (usually a PC board). The center conductor of a coax serves as the feed probe to couple electromagnetic energy in and/or out of the patch. The electric field distribution of a rectangular patch excited in its fundamental mode is also indicated [22]. The electric field is zero at the center of the patch, maximum (positive) at one side, and minimum (negative) on the opposite side. It should be mentioned that the minimum and maximum continuously change side according to the instantaneous phase of the applied signal. The electric field does not stop abruptly at the patch's periphery as in a cavity, rather, the fields extend the outer periphery to some degree. These field extensions are known as fringing fields and cause the patch to radiate. Some popular analytic modeling techniques for patch antennas are based on this leaky-cavity concept. Therefore, the fundamental mode of a rectangular patch is often denoted using cavity theory as the  $H_{10}$  mode.

Since this notation frequently causes confusion, we will briefly explain it. TM stands for transverse magnetic field distribution. This means that only three field components are considered instead of six. The field components of interest are: the electric field in the  $z$  direction and the

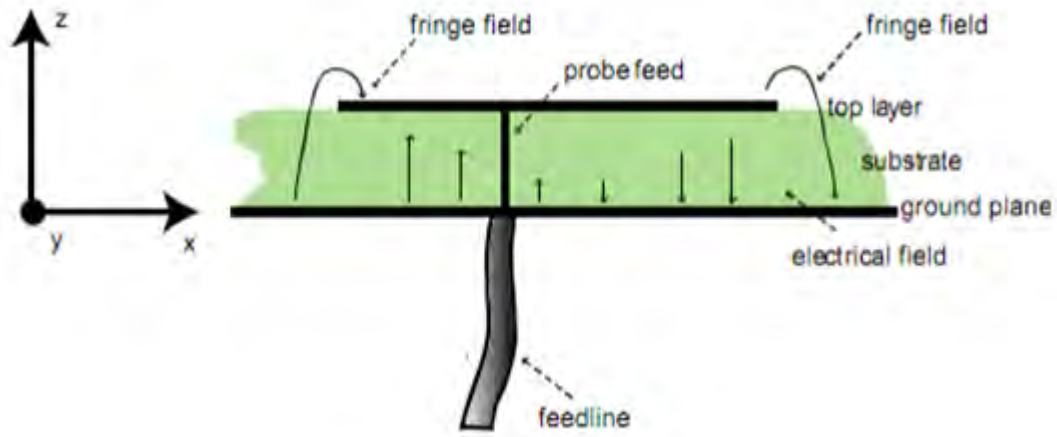

Figure 3.9: Side views of Micro strip Patch Antenna[22]

magnetic field components in x and y direction using a Cartesian coordinate system, where the x and y axes is parallel with the ground L-lane and the z -axis is perpendicular. In general, the modes are designated as  $TM_{nm}$ . The z value is mostly omitted since the electric field variation is considered negligible in the z- axis. Hence  $nm$  remains with n and m the field variations in x and y direction. The field variation in the y direction (impedance width direction) is negligible Thus m is zero. And the field has one minimum-to- maximum variation in the x direction (resonance length direction).

### 3.5.2 Basic Characteristics

Micro strip antennas, as shown in Figure 3.10, consist of a very thin ( $t \ll \lambda_0$ , where  $\lambda_0$  is the free space wavelength) metallic strip (patch) placed a small fraction of a wavelength ( $\lambda_0$ , usually  $0.03\lambda_0 \leq h \leq 0.05\lambda_0$ ) above a ground plane. The micro strip patch is designed so its pattern maximum is normal to the patch (broadside radiator). This is accomplished by properly choosing the mode (field configuration) of excitation beneath the patch. End-fire radiation can also be accomplished by judicious mode selection. For a rectangular patch, the length L of the element is usually  $\lambda_0/3 < L < \lambda_0/2$ . The strip (patch) and the ground plane are separated by a dielectric sheet (referred to as the substrate). There are numerous substrates that can be used for the design of micro strip antennas, and their dielectric constants are usually in the range of  $2.2 \leq \epsilon_r \leq 12$ . The ones that are most desirable for good antenna performance are thick substrates whose dielectric constant is in the lower end of the range because they provide better efficiency, larger bandwidth, loosely bound fields for radiation into space, but at the expense of larger element size. The radiating elements and the feed lines are usually photo-etched on the dielectric substrate. The radiating patch may be square, rectangular, thin strip (dipole), circular, elliptical, triangular, or any other configuration. Square, rectangular, dipole (strip), and

circular are the most common because of ease of analysis and fabrication, and their attractive radiation characteristics, especially low cross-polarization radiation [1].

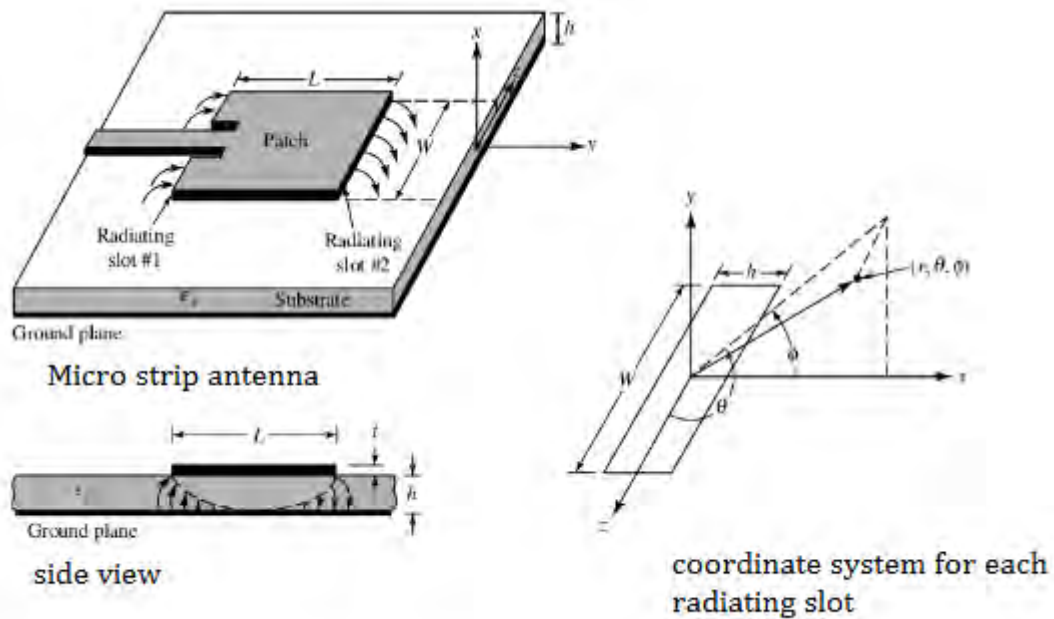

Figure 3.10: Micro strip antenna and coordinate system[1]

### 3.5.3 Radiation Pattern

The antenna radiation pattern, or antenna pattern, is defined as "a mathematical function or a graphical representation of the radiation properties of antenna as a function of space coordinates". Radiation properties include power flux density, radiation intensity, field strength, directivity, phase or polarization. A trace of received electric or magnetic field at a constant radius is called amplitude pattern. A graph of the spatial variation of the power density along a constant radius is called an amplitude power pattern. The radiation pattern can be presented in two forms:

- Azimuth Pattern
- Elevation Pattern

The top view of the energy radiated by an antenna is known as Azimuth Pattern while the graphical side view is called an Elevation. It is determined in the far field region and is represented as a function of the directional coordinates. Using the "electric current model" or a "magnetic current model", we can resolve the radiation field of the micro strip antenna. Usually, the current is used directly to find the far-field radiation pattern. Figure 3.11, shows the electric current for the (1, 0) patch mode. If the substrate is neglected (replaced by air) for the

calculation of the radiation pattern, the pattern may be found directly from image theory. If the substrate is accounted for, and is assumed infinite, the reciprocity method may be used to determine the far-field pattern [9]. In the magnetic current model, the equivalence principle is used to replace the patch by a magnetic surface current that flows on the perimeter of the patch. Figure 3.12, shows the magnetic current for the (1,0) patch mode. The magnetic surface current is given by the following:

$$M = -\hat{n} \times E$$

Where,  $\hat{n}$  is the outward pointing unit-normal vector at the patch boundary, and E is the electric field of the cavity mode at the edge of the patch. The far-field pattern can be determined

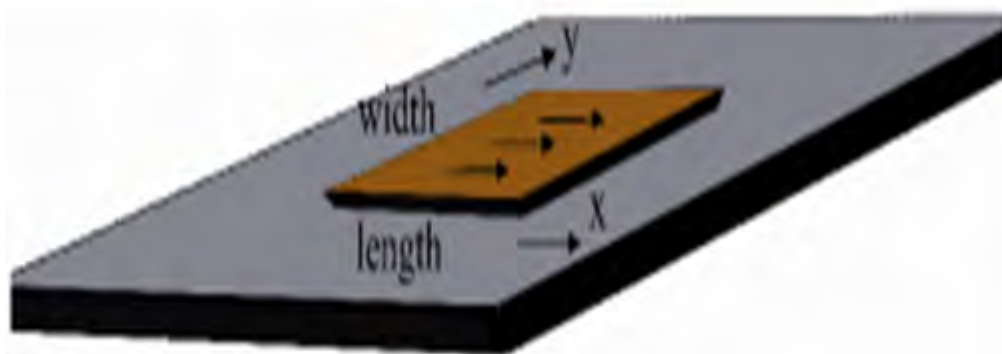

Figure 3.11: Electrical current for (1, 0) patch[9]

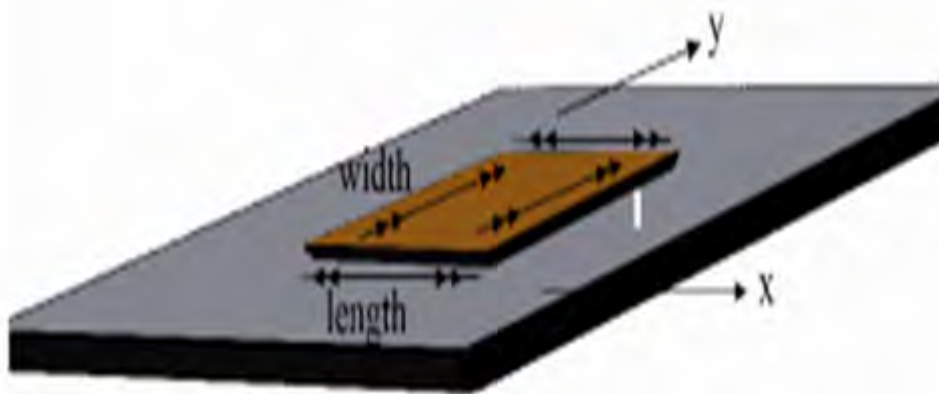

Figure 3.12: Magnetic current for (1, 0) patch[9]

by image theory or reciprocity, depending on whether the substrate is neglected or not. The dominant part of the radiation field comes from the "radiating edges" at  $x = 0$  and  $x = L$ . The two non-radiating edges do not affect the pattern in the principle planes (the E plane at  $\Phi = 0$  and the H plane at  $\Phi = \pi/2$ ), and have a small effect for other planes. It can be shown that the electric and magnetic current models yield exactly the same result for the far-field pattern,

provided the pattern of each current is calculated in the presence of the substrate at the resonant frequency of the patch [9]. In another word, radiation pattern is defined as the power radiated or received by an antenna in a function of the angular position and radial distance from the antenna. It describes how an antenna directs the energy it radiates. The following is a radiation pattern, Figure 3.13, of a generic dimensional antenna, which consist of main lobe, side lobes, and black lobes. Side and back lobes are undesirable as they represent the energy that is wasted for transmitting antennas and noise sources at the receiving end.

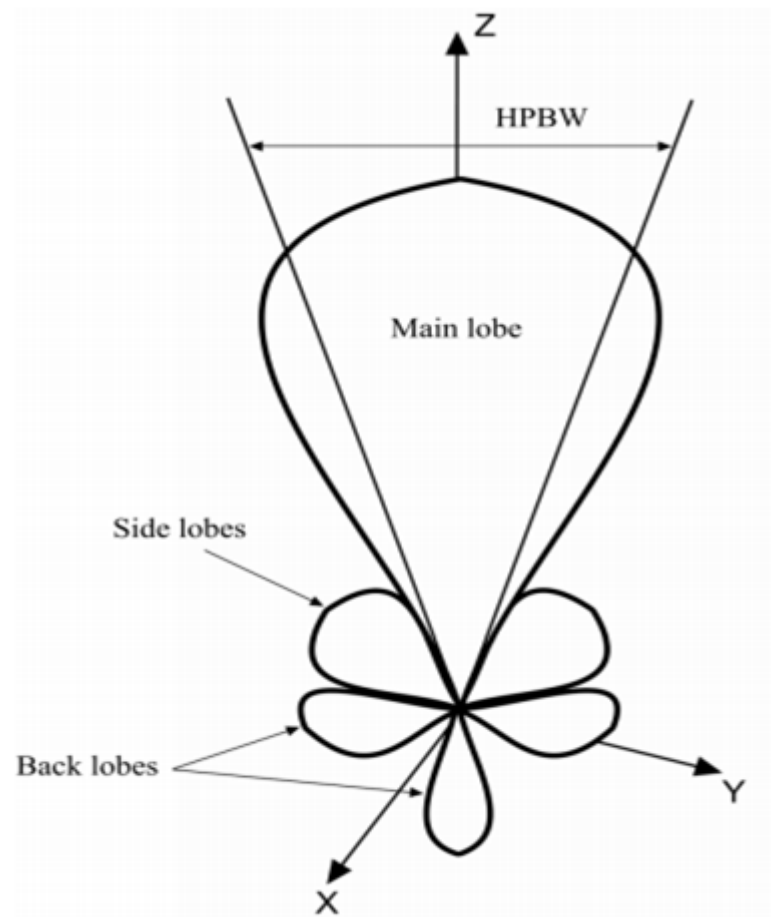

Figure 3.13: Radiation pattern of a generic directional antenna[9]

### 3.5.4 Return loss

In telecommunications, return loss is the loss of signal power resulting from the reflection caused at a discontinuity in a transmission line. This discontinuity can be a mismatch with the terminating load or with a device inserted in the line. The return loss is related to both standing wave ratio (VSWR) and reflection coefficient ( $\Gamma$ ). The increase of return loss corresponds to lower VSWR. An ideal transmission line would have a VSWR of 1:1, with all the power reaching the destination and no reflected power. As for the reflection coefficient ( $\Gamma$ ), it is the ratio of the

amplitude of the reflected wave  $V_0^-$  to the amplitude of the incident wave  $v_0^+$ . In another word, return loss is the measurement of how well devices or lines are matched and a match is good if the return loss is high. A high return loss is desirable and results in a lower insertion loss. Using return loss we can provide the best and most convenient method to calculate the input and output of the signal sources. The Return Loss is determined in dB as follows [19]:

$$RL(dB) = -20\log|\Gamma| \quad (3.6)$$

or

$$RL(dB) = -20\log|S_{11}| \quad (3.7)$$

Where:

$$|\Gamma| = \frac{V_0^-}{V_0^+} = \frac{Z_L - Z_0}{Z_L + Z_0}$$

Here,  $S_{11}$  S-parameters  $\Gamma$  reflection coefficient,  $V_0^-$  incident wave,  $V_0^+$  reflected wave,  $Z_L$  and  $Z_0$  are the load and characteristic impedance. During the development of designing the rectangular patch antenna there is a response taken from the magnitude of  $S_{11}$  parameter versus frequency. This is known as the return loss. To have a perfect matching between the antenna and the transmitter,  $\Gamma = 0$  and  $RL = \infty$ , this indicates that there is no power that is returned or reflected but when  $\Gamma = 0$  and  $RL = 0$  dB, this indicated that the power that is sent is all reflected back. It is said that for the practical applications  $VSWR = 2$  is acceptable as the return loss would be - 9.54dB [8].

### 3.5.5 S-parameters

The S-parameters are very important in microwave design for describing the behavior of electrical devices. Most of the electrical properties i.e. gain, return loss, power, VSWR etc. relates to the S parameters. The S-parameters can be observed by sending a signal through an input port and observing the response on an output port. The term impedance is of great importance while calculating the S-parameters because the system should be matched properly, otherwise reflection which will give rise to standing waves and the system will not produce the desired output. The S-parameters  $S_{11}$  and  $S_{22}$  represent input and output reflection while  $S_{21}$  is the forward transmission coefficient (gain) and  $S_{12}$  are the reverse transmission coefficient (isolation)[20].

### 3.5.6 Impedance Matching

Impedance matching is the process of removing mismatch loss. That is, we want to minimize the reflection coefficient, to reduce the power reflected from the load (the antenna), and

maximize the power delivered to the antenna. This is one of the fundamental tasks in getting antenna to radiate, and hence is one of the more important topics in antenna theory. To achieve perfect matching, the antenna or load impedance to match the transmission line. Thus  $Z_L = Z_0$  (or  $Z_{in} = Z_0$ ) [21].

### 3.5.7 Radiation Efficiency and Quality Factor

For a micro strip patch antenna, efficiency can be defined as the power radiated from the micro strip element divided by the power received by the input to the element. Factors that affect the efficiency of the antenna and make it high or low are the dielectric loss, the conductor loss, the reflected power (Voltage Standing Wave Ratio VSWR), the cross polarized loss, and power dissipated in any loads in the element. General expression of the radiation efficiency can be found in most books of antennas including references of my research: [21]

$$e = \frac{P_{rad}}{P_{rec}} \quad (3.8)$$

Where:

$P_{rad}$  = Power radiated by the antenna

$P_{rec}$  = Power accepted by the antenna.

Efficiency can also be expressed in terms of the quality factor as follows: [21]

$$e = \frac{\frac{1}{Q_{rad}}}{\frac{1}{Q_t}} \quad (3.9)$$

Where:

$Q_t$  = total quality factor

$Q_{rad}$  = quality factor due to radiation (space wave) losses.

$$\frac{1}{Q_t} = \frac{1}{Q_{rad}} + \frac{1}{Q_c} + \frac{1}{Q_d} + \frac{1}{Q_{sw}} \quad (3.10)$$

Where:

$Q_c$  = quality factor due to conduction losses (ohmic).

$Q_d$  = quality factor due to dielectric losses.

$Q_{sw}$  = quality factor due to surface waves.

Most micro strip antennas have efficiency of between 80 to 90 percent. For a very thin antenna  $h \ll \lambda_0; t \ll \lambda_0$  There are approximate formulas to calculate the quality factor: [21]

$$Q_c = h \sqrt{\pi f \delta \mu} \quad (3.11)$$

$$Q_d = \frac{1}{\tan \delta} \quad (3.12)$$

$$Q_{rad} = \left[ \frac{2\omega\epsilon_r}{\frac{hG_t}{l}} \right] K \quad (3.13)$$

Where:

$\tan \delta$  = loss tangent of the substrate.

$\omega$  = conductivity of the conductor.

$\frac{hG_t}{l}$  = the total conductance per unit length.

### 3.5.8 Bandwidth

Bandwidth is a fundamental antenna parameter. It describes the range of frequencies over where the antenna parameters, such as input impedance, radiation pattern, polarization, side lobe level and gain is within an acceptable value from those at the center frequency. Often, the desired bandwidth is one of the determining parameters used to decide upon an antenna. For instance, many antenna types have very narrow bandwidths and cannot be used for wide band operation.

### 3.5.9 Radiation Intensity (U)

. The radiation intensity is far field parameter[17].

$$U = r^2 P_{rad} \quad (3.14)$$

where: U=Radiation Intensity The radiation intensity is power per unit solid angle.  $P_{rad}$ =Average power radiated by an antenna (watts/ $m^2$ )

$$U = \frac{1}{2} (\vec{E} \times \vec{H}) r^2 \quad (3.15)$$

$$U = \frac{1}{2} \frac{E^2}{\eta^2 r^2} \quad (3.16)$$

An other way:

$$U = r^2 P_{avg} \quad (3.17)$$

Where:

$$P_{avg} = \frac{1}{2} \frac{E^2}{\eta} \quad (3.18)$$

Radiation intensity will indicate about the energy of an antenna. Radiation intensity in a given direction will be defined as the power radiated from an antenna per unit solid angle.

### 3.5.10 Linear Polarization

The polarization is the orientation of the electric field far from the source [2]. It describes the time-varying direction and relative magnitude of the electric field vector. Polarization for an

antenna in a given direction is defined as the polarization of the E-field transmitted (radiated) by the antenna. When the direction is not stated the polarization is taken to be the polarization in the direction of maximum gain. The polarization of a wave radiated by an antenna, in a specified direction, at a point in the far field, is defined as the polarization of the plane wave which is used to represent the radiated wave at that point [1]. Polarization may be classified as linear, circular, elliptical, circular left hand, circular right hand, elliptical right and elliptical left hand.

### **3.6 Micro strips Array**

Micro strip patch antennas are a well-known type of low profile antenna, which have gained increasing popularity in the last three decades. They have been widely applied in many wireless communication systems, such as global positioning systems (GPS), wireless local area networks (WLAN), radio frequency identification (RFID) systems, etc. One of main problem in micro strip patch antenna array is the mutual coupling between antennas elements which is attribute to the surface wave. It causes the performance degradation such as impedance mismatching, high side-lobe level and the deviation of the radiation pattern from the desired one. The Electromagnetic Band Gap (EBG) materials offer a unique way to control the excitation of the surface wave in the feeding structure and as such proved to be very effective in reducing the coupling between patch antennas and improving the overall antenna radiation efficiency. Micro strip antenna on high dielectric constant substrate is preferable because of its compact size. Also thick substrate can improve the antenna bandwidth. However these specifications excite surface wave and cause severe mutual coupling between arrays of micro strip antennas. One popular way to achieve electronic scanning in an antenna arrays is to feed array elements by means of phase shifters in such a way that the phase variations along the array follow an arithmetical progression whose common difference is the phase shift between two adjacent elements. Thus the array generates a plane wave whose direction depends on this phase difference [7].

### **3.7 Functional Blocks of micro strip patch Array Antenna.**

Any phased array antenna in general, apart from the array elements, consists of two functional blocks known as feed network and phase scanning circuitry. Each of these blocks plays very important roles for the correct functionality of the array and is described here in detail.

### 3.7.1 Feed Network.

A feed network distributes energy to the elements of the array by means of phase shifters according to a desired amplitude function. Corporate binary feed, as shown in Fig. 3.14 is common in arrays of dipoles, open-end guides and patches. Such feed circuits are commonly binary but can be modified to design 3-way or 5-way dividers, depending upon the number of array elements. The critical component in the corporate feed is the power divider that can be realized by bifurcated T waveguide or coaxial T junctions [6]. One challenge in design of this type of feed network is that each of the elements is required to be impedance matched and isolated or the reflected signal from each element results in a parasitic radiation pattern that will be superimposed on the required pattern. This condition plays an important role in the design of feed networks, where it is often necessary to use a directional couplers or a matched transmission line.

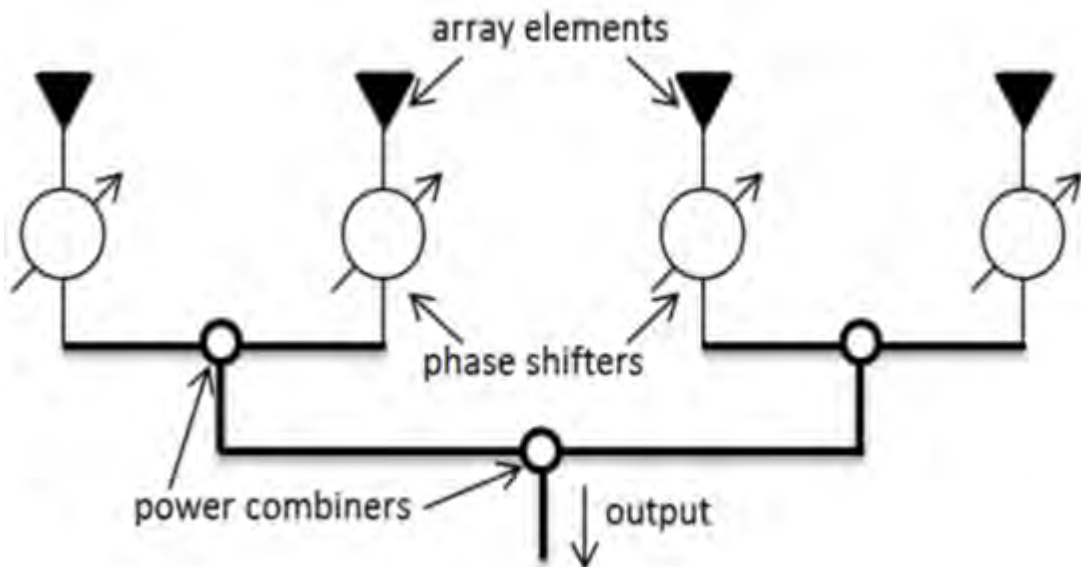

Figure 3.14: Corporate feed structure for an array system [6].

### 3.7.2 Phase Scanning Circuitry

One primary goal of developing phased-array antennas is to achieve beam steering electronically and thus to eliminate the mechanical movement of an antenna system. Electronic beam steering in an array antenna can be realized by time delay scanning, frequency scanning or phase scanning techniques. However, ease of implementation, cheaper digital control circuits, fast response time and high sensitivity make the phase scanning method the most popular. For proper functionality, a clever choice for a phase shifter is a switched line or ferrite phase shifter with analog or digital control. A good choice for the placement of phase shifters along the feed

line is also a very important factor. The orientation may be in series or in parallel, as shown in Fig. 3.15. Although the series phasers have the advantage of sharing equal power, the disadvantage is the phase compensation circuit because the basic inter element phase shift must be multiplied by the number of elements and the attenuations of the phasers add up along the feed line. On the contrary, for parallel combination, although each phase shifter does not share the same power, the major advantage is all phasers are independent of each other and thus modeling of the control circuit becomes simpler [20].

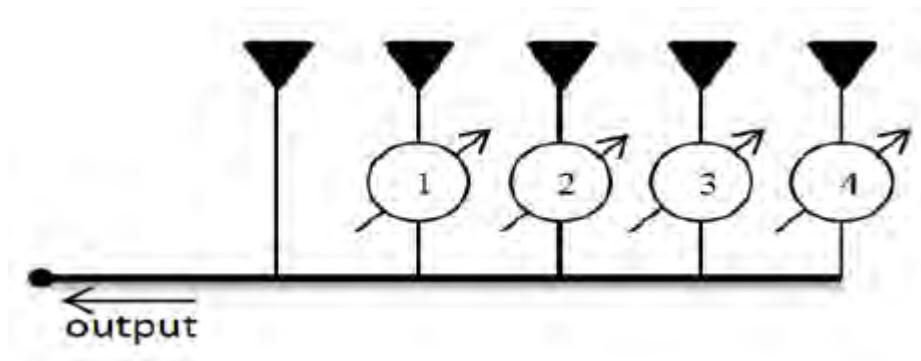

Figure 3.15: parallel phasers [23]

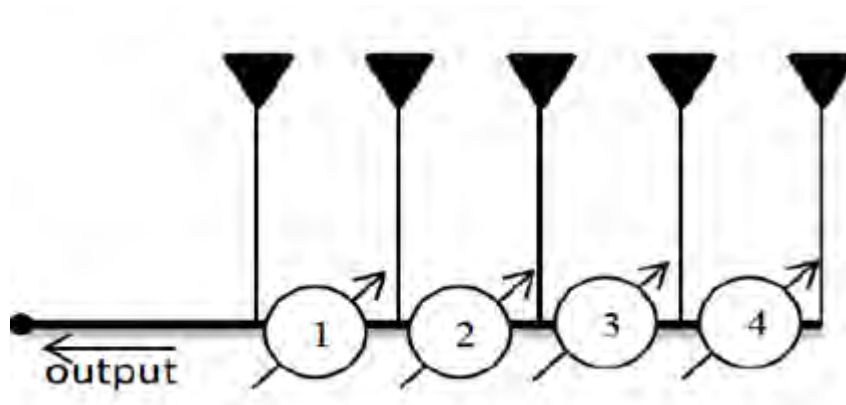

Figure 3.16: series phasers [23]

### 3.7.3 Controlling Parameters of an Array Antenna System

Two important properties of any individual antenna are return loss and radiation pattern. Return loss is the measurement of impedance mismatch along the path of propagation of the signal. Often termed as ( $S_{11}$ ), this parameter determines the reflection coefficient ( $\Gamma$ ) of the system. The radiation pattern or the field pattern describes the angular dependency of the strength of the radio waves received by the antenna, usually expressed in dB (and sometimes in dBi when compared with the field pattern of an isotropic radiator).

### **3.7.4 Geometrical orientation of the overall array**

The geometrical orientation of the array may be linear, planar, circular, spherical etc. in nature. When the array elements lie along a straight line, it will be denoted as a linear array and when these are located on a plane, the array will be denoted as a planar array. Depending upon the spatial distribution of the array elements, a planar array may be designed as a circular or rectangular array. However, for each of the cases, the effective field distribution and mutual coupling will be different from one another.

### **3.7.5 Relative separation between the elements**

The relative spacing between the elements of the array determines the position of the peak and the null of the field pattern, and hence, careful choices need to be taken during the design of an array.

### **3.7.6 Excitation amplitude of the individual element**

Amplitudes of the current on the elements of an array can be varied to shape the beam and control the level of the side lobes of the array. This phenomenon is known as amplitude tapering and the arrays of these types are termed as non-uniformly excited arrays [14].

### **3.7.7 Excitation phase of the individual element**

The relative phases of the currents on each individual element of an array can be controlled to reinforce the field pattern of the array in a particular direction. These types of arrays are known as phased array antennas.

### **3.7.8 Relative pattern of the individual element**

The overall response of the array is the superposition (sum) of all individual elements of the arrays excited separately and thus can be mathematically determined by a Fourier transformation. To avoid complexity in terms of design and calculation, generally arrays are considered to be made of identical elements.

## **3.8 Array Factor (AF)**

The array factor due to isotropic point sources is the weighted sum of the signals received by the elements. Mathematically[1],

$$AF = \sum_{n=1}^N W_n \exp^{j\varphi_n} \quad (3.19)$$

where:

N= number of element

$$W_n = \exp^{j\delta_n}$$

Array factor depends on:

- Number of element.
- Relative magnitude and phase of current on each element.
- Relative inter element spacing
- Geometrical orientation of the element.

Use: Pattern multiplication rule. If the response single element of linear array is  $\vec{E}_s$  then the total response of the array  $\vec{E}$  total can be written as:

### 3.9 Array Design

Features:

- Single feed point
- Insertion of phase shifters into corporate feed network
- Introduce the sensor circuit as the feedback network with autonomous controller circuitry for radiation pattern recovery

### 3.10 Mutual Coupling in Antenna Array

One of the basic characteristics of an antenna array appears when two or more elements are located near to each other and affect each other. The amount of coupling depends on the following:

- Radiation characteristics.
- Actual separation between elements.
- Relative orientation of elements.

The mutual coupling between two radiating elements depends upon the distance between them. If they are close to each other the mutual coupling will be greater. Thus energy is transferred between elements and this is called mutual coupling. One can say that the electromagnetic coupling between the elements is mutual.

### **3.11 Need for Antenna Array**

In case where point to point communication is desired, the radiation in one particular direction must be obtained for an elementary dipole; the maximum radiation is at right angles to the axis. The radiation pattern will decrease slowly as the polar angle decreases towards the axis of dipole. It is basically a non-uniform radiation pattern. This could be used in broadcast services, but it is a failure in case of point to point communication.

# Chapter 4

## Design of Rectangular Micro strip Patches

### Array Antenna

#### 4.1 Introduction

The rectangular patch antenna is approximately a one-half wavelength long section of rectangular Micro strip transmission line. When air is the antenna substrate, the length of the rectangular Micro strip antenna is approximately one-half of a free-space wavelength [1, 2]. The length of the antenna decreases as the relative dielectric constant of the substrate increases. The antenna has become a necessity for many applications in recent wireless communication such as radar, microwave and space communication. The specifications for the design purpose of the structure are as follows

- Type of antenna: Rectangular Micro strip Patch antenna
- Resonance frequency: 2.6 GHz.
- Input impedance:  $50\Omega$
- Feeding method: Micro strip Line Feed

#### 4.2 Design parameters

##### 4.2.1 Substrate Material

The first step in the design process is the selection of a dielectric substrate material. The dominant features of a micro strip array are controlled by substrate parameters such as thickness and permittivity more than by the particular element type. Because weight is a primary consideration in cellular system, a substrate must be chosen which not only has satisfactory dielectric properties, but which also has low density. There are a variety of substrate materials available with a wide range of relative dielectric constants and densities [21].

## 4.2.2 patch Parameters

The dimensions of a rectangular patch, as well as bandwidth and gain, are determined by the operating frequency of the antenna, the relative dielectric constant, and thickness of the substrate material. The following formulas are based on the transmission line model.

## 4.2.3 Width and Length

The width and length of a rectangular micro strip patch are given by [1][21]:

$$W = \frac{C}{2f_r \sqrt{\frac{\epsilon_r + 1}{2}}} \quad (4.1)$$

$$L = \frac{C}{2f_r \sqrt{\epsilon_e}} - 2\Delta L \quad (4.2)$$

Where:

$C$  = speed of light (m/s).

$f_r$  = operating frequency (MHz).

$\epsilon_r$  = relative dielectric constant.

$\epsilon_e$  = effective dielectric constant.

Where:

$\epsilon_e$  from equation(3.1)

$$\epsilon_e = \frac{\epsilon_r + 1}{2} + \frac{\epsilon_r - 1}{2} \left[ 1 + \frac{12h}{w} \right]^{-1/2}$$
$$\Delta L = 0.412h \frac{(\epsilon_e + 0.3) \left( \frac{W}{h} + 0.264 \right)}{(\epsilon_e - 0.258) \left( \frac{W}{h} + 0.8 \right)} \quad (4.3)$$

where

$h$  = dielectric thickness (mm)

## 4.3 Design Specifications

Before designing the antenna, the first step is to consider the specification of the antenna based on its application. The various parameters that are used for thesis are taken from the data sheet of FR4 and listed in Table 4.1. The frequency 2.6 GHz is chosen because the frequency is suitable to test with the cell phone application. The frequency also is widely use in a LTE application and the antenna can be used as a mobile device antenna. As for the substrate selection, the major consideration will be the dielectric constant and loss tangent. A high dielectric constant will result in a smaller patch size but this will generally reduce bandwidth efficiency and might have difficulty in fabricating a very small patch size antenna. A high loss tangent will reduce the antenna efficiency.

Table 4.1: Single Patch Antenna Design Specifications.

| Parameters                         | Specification |
|------------------------------------|---------------|
| Frequency                          | 2.6 GHz       |
| Substrate                          | FR4           |
| Dielectric constant , $\epsilon_r$ | 4.4           |
| Loss tangent                       | 0.019         |
| Substrate height                   | 1.6 mm        |
| Conductor thickness                | $35\mu m$     |

### 4.3.1 Single Micro strip Patch Antenna Design

The objective of this part is to design a single micro strip patch antenna which consists of patch, Quarter wave transformer and feed line. For the patch antenna design, a rectangular patch antenna is used. Since a  $50\Omega$  surface mount adapter (SMA) connector is going to be used to connect the feed line to the coaxial cable, the feed line will be a  $50\Omega$  feed line. The feed line will be fed to the patch through a matching network which is a quarter-wave transformer[1][16]. The impedance of the quarter-wave transformer is given by the equation:

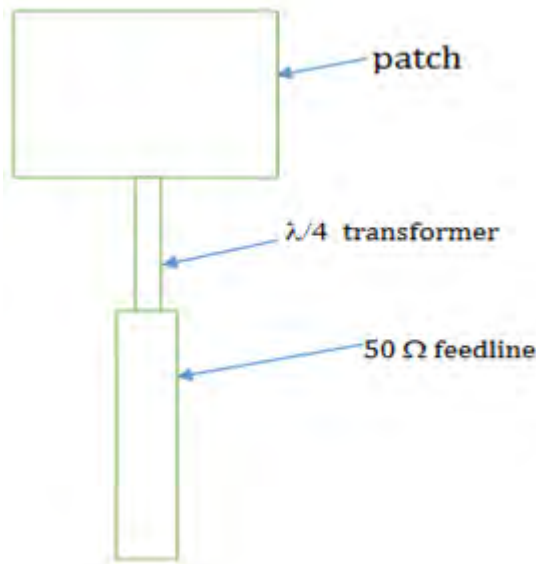

Figure 4.1: Patch Antenna with Quarter-Wave Transformer

$$Z_1 = \sqrt{R_{in} Z_0} \quad (4.4)$$

Where:  $Z_1$  is the transformer characteristic impedance and  $Z_0$  is the characteristic impedance (real) of the input transmission line.  $R_{in}$  is the edge resistance at resonance. and

$$R_{in} = \frac{1}{2G_e} \quad (4.5)$$

Where:

$$G_e = 0.00836 \frac{W}{\lambda_0} \quad (4.6)$$

represent of edge conductance and  $\lambda_0$  free space wave length

### 4.3.2 Patch Calculations

The micro strip patch antenna calculation of width ( $w$ ), length, the improve length ( $L$ ), and fringe factor  $\Delta L$ . The width of a rectangular micro strip patch is from equation (4.1):

$$W = \frac{3 * 10^8}{2 * 2.6 * 10^9 \sqrt{\frac{4.4+1}{2}}} = 34.2mm$$

The dielectric constant of a rectangular micro strip patch is from equation (3.1):

$$\epsilon_e = \frac{4.4+1}{2} + \frac{4.4-1}{2} \left[ 1 + \frac{12h}{w} \right]^{-1/2} = 5.34$$

The length extension of a rectangular micro strip patch is from equation (4.3):

$$\Delta L = 0.412h \frac{(5.34 + 0.3) \left( \frac{34.2 * 10^{-3}}{1.6 * 10^{-3}} + 0.264 \right)}{(5.34 - 0.258) \left( \frac{34.2 * 10^{-3}}{1.6 * 10^{-3}} + 0.8 \right)} = 7.14 * 10^{-4}$$

$$L = \frac{3 * 10^8}{2 * 2.6 * 10^9 \sqrt{5.34}} - 2 * 7.14 * 10^{-4} = 24.256mm$$

### 4.3.3 Ground plane dimensions calculation (Lg and Wg)

Only for infinite ground planes, most of model is applicable, but for practical considerations finite ground plane is required. Same results for finite and infinite ground plane are obtained if, in case of infinite ground plane the size of the ground plane around the periphery is greater than the patch dimensions by six times thickness of substrate. Hence, for proposed design dimensions of ground plane would be given as: [1]

$$Lg = 6h + L = 6 * 1.6 + 24.256 = 33.856mm \quad (4.7)$$

$$Wg = 6h + W = 6 * 1.6 + 34.2 = 43.8mm \quad (4.8)$$

## 4.4 Micro strip Discontinuities

Surface waves are electromagnetic waves that propagate on the dielectric interface layer of the micro strip. The propagation modes of surface waves are practically TE and TM. Surface waves are generally at any discontinuity of the micro strip. Once generated, they travel and radiate, coupling with other micro strip of the circuit, decreasing isolation between different networks and signal attenuation. Surface waves are a cause of crosstalk, coupling, and attenuation in a multi-micro strip circuit. For this reason surface waves are always an undesired phenomenon [9]. A discontinuity in a micro strip is caused by an abrupt change in geometry of the strip conductor, and electric and magnetic field distributions are modified near the discontinuity. The altered electric field distribution gives rise to a change in capacitance, and the changed magnetic field distribution to a change in inductance. [10]

### 4.4.1 Bends

Four  $90^\circ$  bends were encountered in the design. This brought about excess capacitance at the square corners making the characteristic impedance value to be lower than that of the uniform connecting lines. A bend of this angle doesn't work well above a few GHz due to a high VSWR. The same holds true for bends with angles greater than  $90^\circ$ . Compensation for the micro strip corner bend was made by the use of decreased capacitance technique. Since experiments on various bends have proven that a decrease in the input reflection coefficients can be achieved if the corner is chamfered (mitered), the following configuration was applied [21]

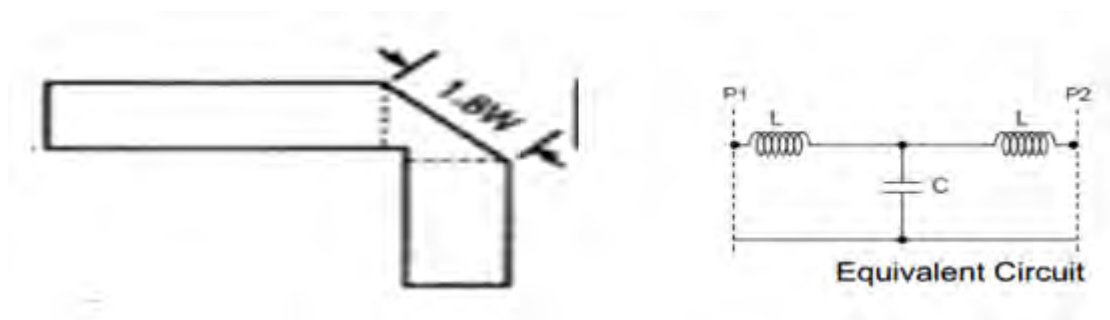

Figure 4.2: right-angled bends with its equivalent circuit; W is the width of the line [21]

### 4.4.2 Step Width Junction

This discontinuity was found at the  $\frac{\lambda}{4}$  Transformers. The effect of the fringing capacitance associated with the wider line of the step discontinuity is similar to an increase in the length of that line. In terms of distributed elements, the discontinuity capacitance C has the effect of an increase in length of the wide line  $w_1$ , and an equal decrease in length of the narrow line  $w_2$ .

To compensate for the excess capacitance, the wider line  $w_1$  was made to be electrically longer by a length of 9.26mm [23].

### 4.4.3 T-Junction

These discontinuities were found in the patch antenna array as branch -lines. The T-Junctions were easily compensated by simply adjusting the lengths of the different lines. The offset in the

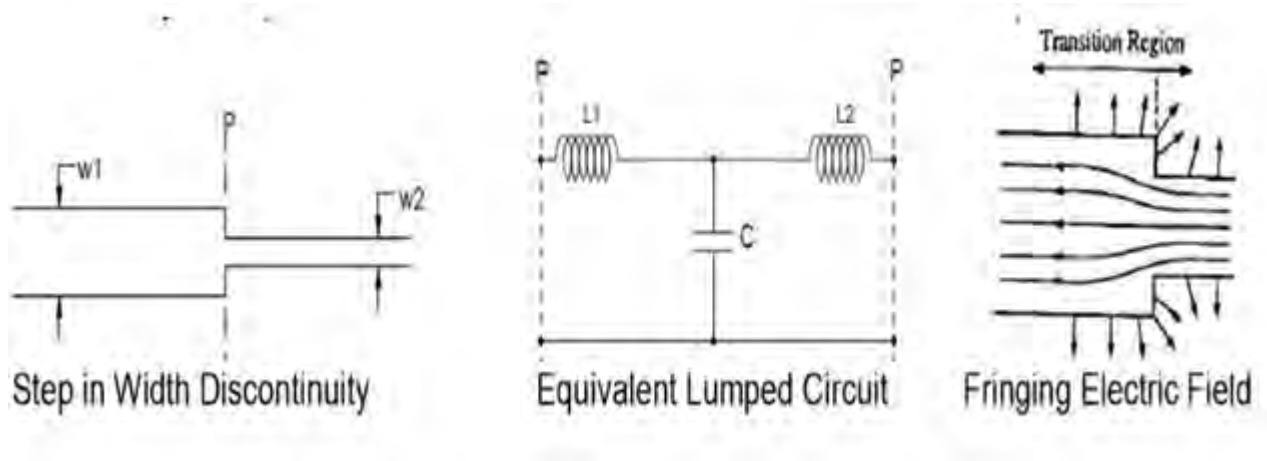

Figure 4.3: Characteristics of the step width junction discontinuity [22]

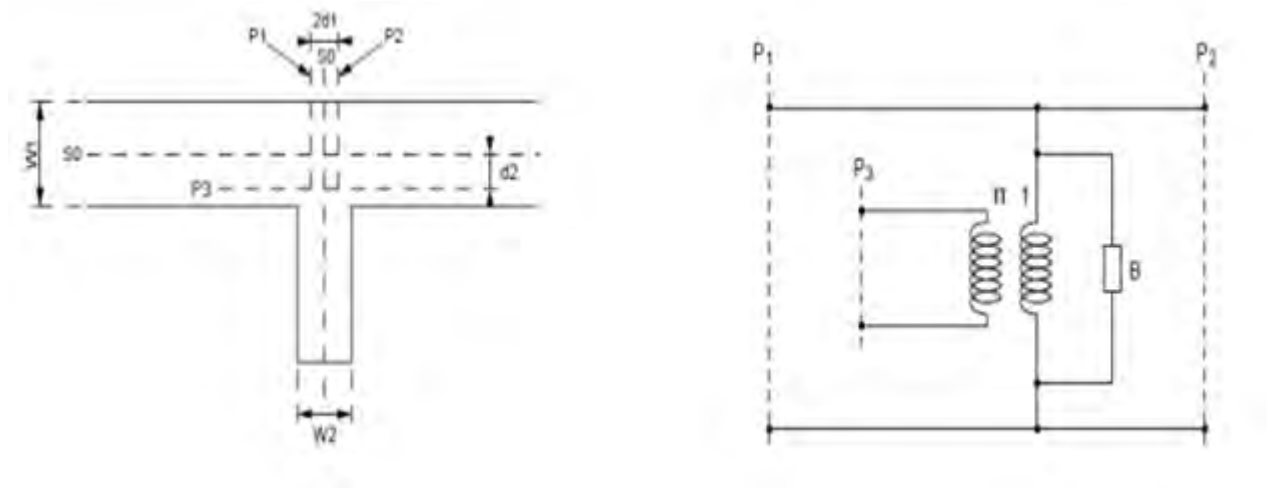

Figure 4.4: Junction discontinuity and the Equivalent Circuit [24]

$$w_1 = 12 = 2.62mm, 0.7 \times w_1 = 0.7 \times 2.62 = 1.834mm$$

The best solution to the transformer effect is to keep the width of the stub  $W_2$  narrow enough for the transforming effect to be negligible. Calculation of the Impedance for Quarter-Wave Transformer The quarter-wave transformer impedance and the edge resistance at resonance: To compute the impedance for the quarter-wave transformer from equation (4.4):

$$Z_1 = \sqrt{R_{in} Z_0}$$

$G_e$  the edge conductance and given by:

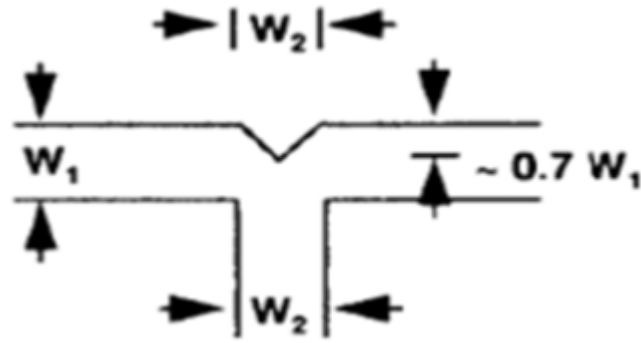

Figure 4.5: T-junction discontinuity compensation and minimization of the effect [24]

$$G_e = 0.00836 \frac{W}{\lambda_0} = 2.4776 * 10^{-3}$$

Then  $R_{in}$  the edge resistance and can be calculating from equation (5.5):

$$R_{in} = \frac{1}{2G_e} = 208.81\Omega$$

The impedance of the quarter-wave transformer is given by the equation:

$$Z_1 = \sqrt{208.81 * 50} = 100\Omega$$

Table 4.2: Dimension of Rectangular Patch Antenna.

| Parameters                                 | Specification |
|--|---------------|
| Width of Patch                             | 34.2mm        |
| length of Patch                            | 25.256mm      |
| width of $\frac{\lambda}{4}$ transformers  | 1.0mm         |
| length of $\frac{\lambda}{4}$ transformers | 13.0mm        |
| Width of 50Ω feed line                     | 3.0mm         |
| length of 50Ω feed line                    | 32.5mm        |

#### 4.4.4 Radiation Pattern Calculation

The radiation pattern of the patch antenna can be calculated by using the equation: For E plane:

$$F(\theta) = \frac{\sin(\frac{K_0 h}{2} \cos(\theta))}{\frac{K_0 h}{2} \cos(\theta)} \cos(\frac{K_0 h}{2} \cos(\theta)) \quad (4.9)$$

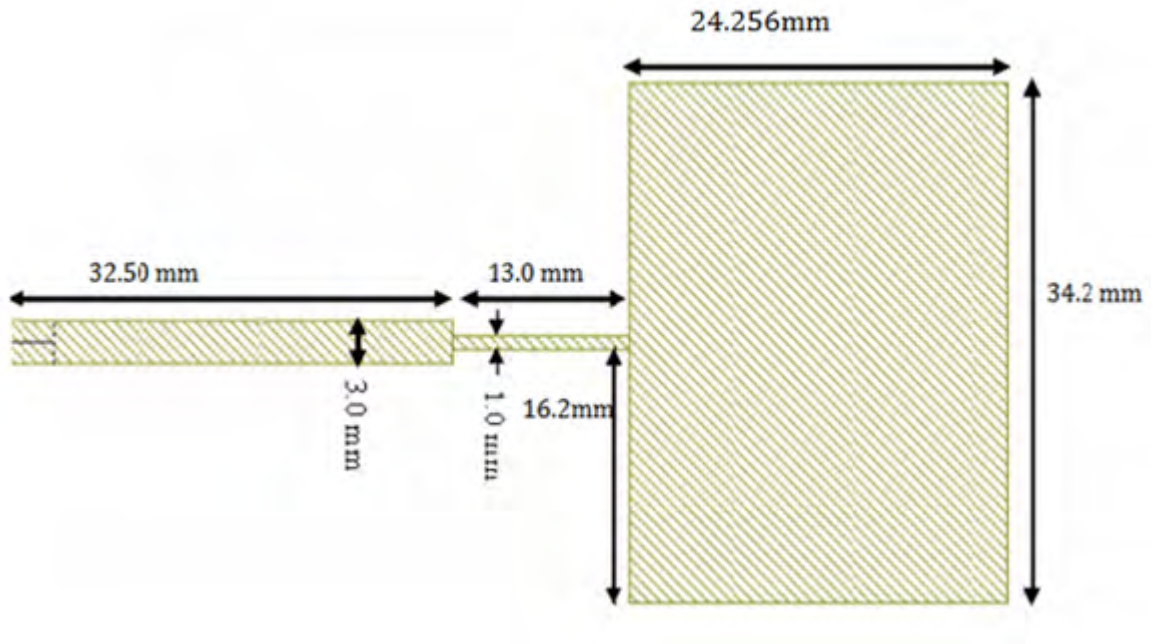

Figure 4.6: Single Patch Antenna Design Layout.

For H plane.

$$F(\theta) = \frac{\sin\left(\frac{K_0 h}{2} \cos(\phi)\right)}{\frac{K_0 h}{2} \cos(\phi)} \cos(\phi) \quad (4.10)$$

Where:

$$K_0 = \frac{2\pi}{\lambda}$$

After all the important parameter has calculated, then the design procedure is preceding to simulation stage using mat lab software.

#### 4.4.5 Micro strip Patches Array Antenna Design

The existing feed methods for micro strip array can be categorized into series and corporate (parallel) feeds. Series feed normally consist of a continuous transmission line connected with a series of patch element as shown in Figure 4.7. Small portions of energy are coupled into the next element by various means which include proximity coupling, probe coupling or aperture coupling. There are two typical configurations for series feed arrays, transposed and un trans-



Figure 4.7: Series Feed network

posed. Figure 4.7 shows the un transposed configuration. As compared to parallel feed, series feed will normally have better overall antenna efficiency. This is because the number feed lines are fewer for the series feed which reduces the insertion loss. However series feed array have narrow bandwidth and inherent beam shift with frequencies due to the insertion phase shift of the patches. Corporate feed has a single input port and multiple feed lines in parallel which is terminated at an individual radiating element which could be a patch. One basic corporate feed is a one-dimensional network which consists of a two way power divider. This configuration is shown in Figure 5.8, this configuration is known as corporate feed and is the most widely used configuration. In this configuration, antenna elements are fed by 1: n power divider network. The power is equally divided at each junction if the lines distributions are symmetric. If the distance of from each radiating element to the input port is identical, the beam position is independent of the frequency. So by varying the position of the input with method such as line extension, the beam direction can be controlled. This is one of the advantages of this configuration. Others include design simplicity, flexible choice of element spacing and boarder bandwidth. The disadvantage of this feed is that since long transmission lines are used, insertion loss is also larger, reducing the efficiency of the array.[25] In this thesis, the corporate feed network is chosen for designing four element array networks. The array antenna consists of a branching network of two-way power dividers. Quarter-wave transformers ( $70\Omega$ ) are used to match the  $100\Omega$  lines to the  $50\Omega$  lines. Figure 5.8 shows the impedance for individual lines in the four element array antenna.

## 4.5 Array Calculation

The array calculation consists of two parts. The first is the patch calculation and the second is for  $50\Omega$ ,  $70\Omega$  and  $100\Omega$  transmission lines.

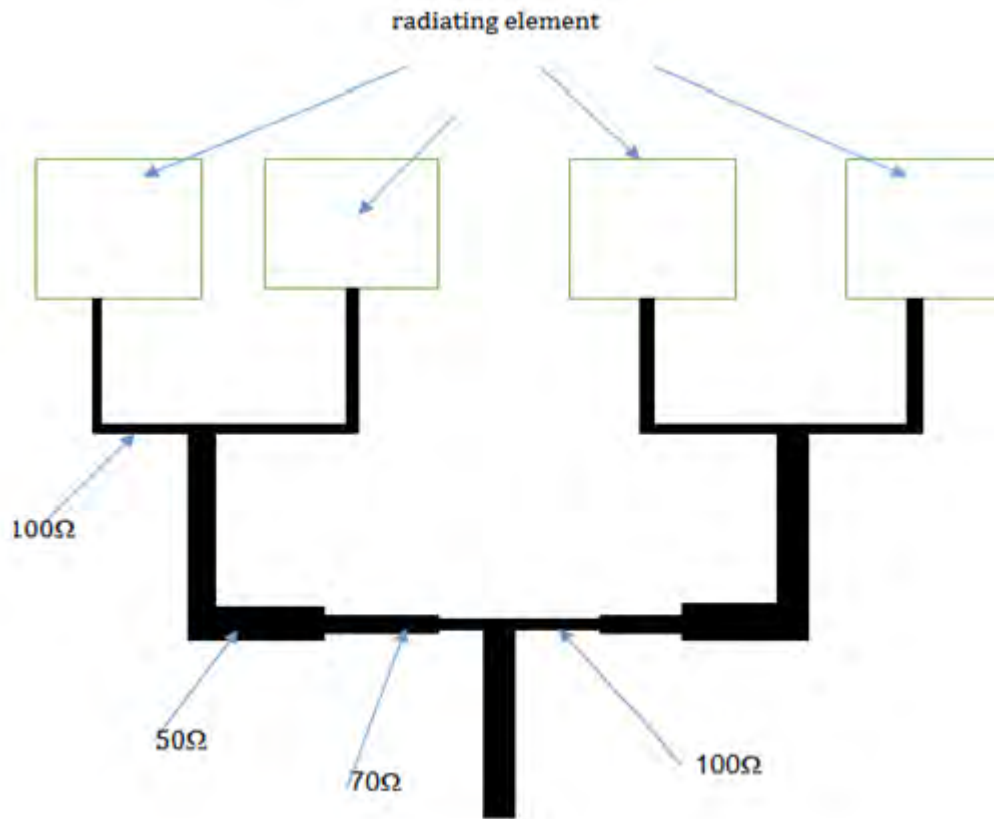

Figure 4.8: Four Elements Array Line Impedance Design Layout

#### 4.5.1 Calculation of the Impedance for Quarter-Wave Transformer

Using the following equation where by replacing  $Z_0 = 50\Omega$  and  $R_{in} = 100\Omega$  The transformer Characteristic impedance as illustrate in equation(4.4):

$$Z_1 = \sqrt{R_{in}Z_0}$$

$$Z_1 = \sqrt{100\Omega \times 50\Omega} = 70\Omega$$

50Ω,70Ω and 100Ω Transmission Line Calculation As a single patch, the different impedance dimensions are obtained by using the same TX line Calculator. The dimensions of the array are shown in the table 5.2 and figure5.9

Table 4.3: Dimension of Rectangular Patches Array Antenna.

| Parameters               | Specification |
|--------------------------|---------------|
| Width of Patch           | 34.2mm        |
| length of Patch          | 25.256mm      |
| width 100Ω feed line     | 1.0mm         |
| length of 100Ω feed line | 34.5mm        |
| Width of 70Ω feed line   | 2.0mm         |
| length of 70Ω feed line  | 17.0mm        |
| Width of 50Ω feed line   | 3.0mm         |
| length of 50Ω feed line  | 32.5mm        |

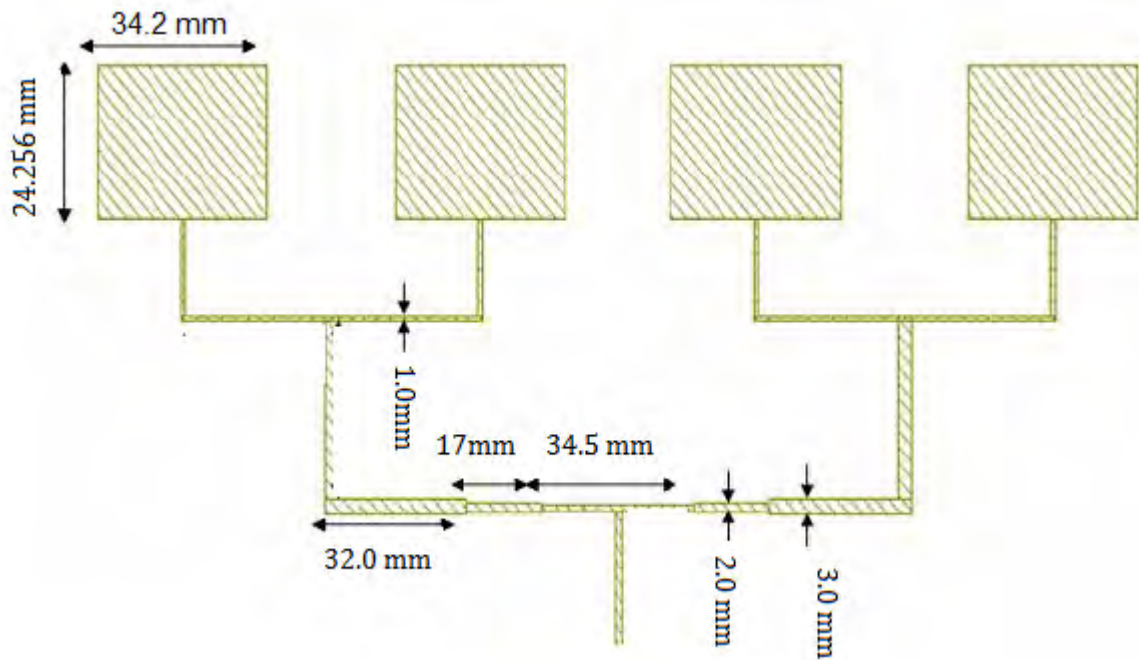

Figure 4.9: Layout Design of 4x1 Array Antennas

# Chapter 5

## Results and Discussion

### 5.1 Introduction

In this chapter, the numerical parameters that are used for evaluating the performance of the designed 2.6GHz 4x1 linear phase rectangular antenna array for long term evolution (LTE) applications are introduced. After the formation of the sets of the initial conditions, the results of the performed computer simulations are presented in the form of tables and figures. And finally, the results will be discussed in term of the selected parameters for comparison. Most of MATALAB source code for carrying out this simulation taken from mat works by substitutes our simulation parameter.

### 5.2 Results and Discussion

After selecting the substrate parameter, calculating some model parameter and designing patch array antenna, the computer simulations are carried out by formulating a program using MATLAB for all the configurations and scenarios are defined in Chapter 4. Performing the relevant computer simulations for each of these situations separately, the corresponding directivity, bandwidth efficiency, return loss and VSWR of patch array antenna are determined as given in Table 5.1 and 5.2. From this table we can see that the patch array antenna more advantage than single patch antenna.

Table 5.1: Comparison of Performance and Result of a RMP antenna for same Thickness  $h$  of substrate at same Dielectric constant

| Quantity             | Single patch antenna | Array antenna    |
|----------------------|----------------------|------------------|
| Patch Dimensions     | 24.256 x 34.2 mm     | 24.256 x 34.2 mm |
| Directivity          | 4.46dB               | 9.66dB           |
| Bandwidth efficiency | 4.5%                 | 12.5%            |
| Return loss (dB)     | -17.5dB              | -11.5dB          |

As we can see from Table 5.1 and 5.2 in all conditions the rectangular micro strip patch array antenna have achieved a better performance than that of single micro strip antenna. The per-

Table 5.2: Comparison of Performance and Result of a RMP array antenna for different Thickness  $h$  of substrate at same Dielectric constant

| Parameters                | $h=1.5\text{mm}$ | $h=1.7\text{mm}$ | $h=1.9\text{mm}$ |
|---------------------------|------------------|------------------|------------------|
| Return Loss $S_{11}$ (dB) | -11.5dB          | -14dB            | -16.5dB          |
| VSWR                      | 1.7              | 1.5              | 1.35             |
| Bandwidth                 | 4.5%             | 7.25%            | 12.5%            |
| Directivity(dBi)          | 9.66dB           | 9.64dB           | 9.42dB           |

formance of the rectangular micro strip patch array antenna that investigated in this study is good radiation pattern, minimum return loss and more directives by considering the bandwidth efficiency with single patch antenna. This comparison is computed for the same dielectric substrate with the same substrate thickness but as we increase its thickness with the same dielectric substrate, the directivity of patch array antenna slightly decrease and increase the bandwidth efficiency. This achieves our objective that set in the proposal of the thesis. Those performance metrics of rectangular micro strip patch array antenna compare with hypothetic cosine antenna element that has the significant pattern coverage and a cosine antenna pattern is an appropriate choice for the initial design since it does not radiate any energy backwards. The performance of our design is comparable with the hypothetic cosine antenna element in those performance metrics. For this thesis our contribution is to visualize the return loss, the radiation pattern and the directivity by designing of single patch antenna and rectangular micro strip patch array antenna.

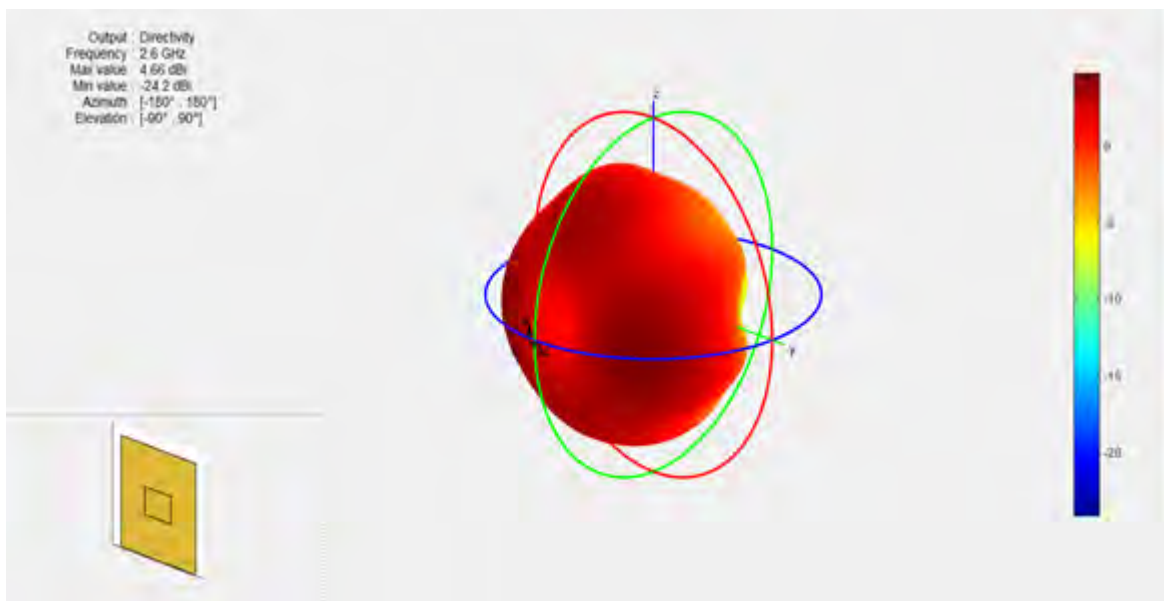

Figure 5.1: 3D directivity of single Patch Antenna

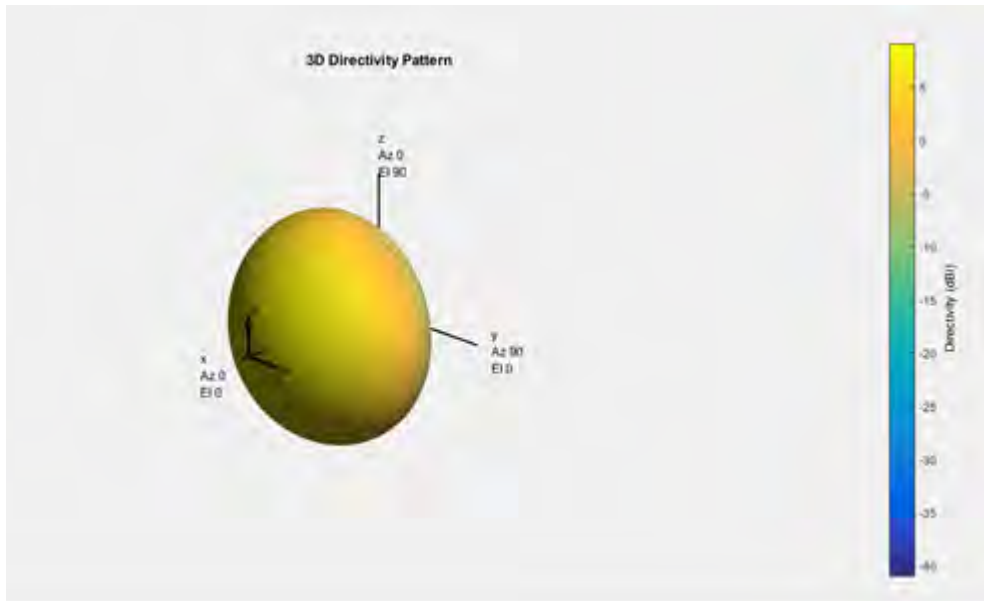

Figure 5.2: 3D directivity of single cosine Antenna element

As it is shown in Figure 5.1 and 5.2, the 3D far field plots of the antenna radiates in broadside direction with maximum directivity of 4.46dB and 7.6dB for single rectangular micro strip patch antenna and for single cosine antenna element respectively. From this we deduce that single rectangular micro strip patch antenna is not directive as compare to cosine antenna element. To increase the directivity we have to design array antenna.

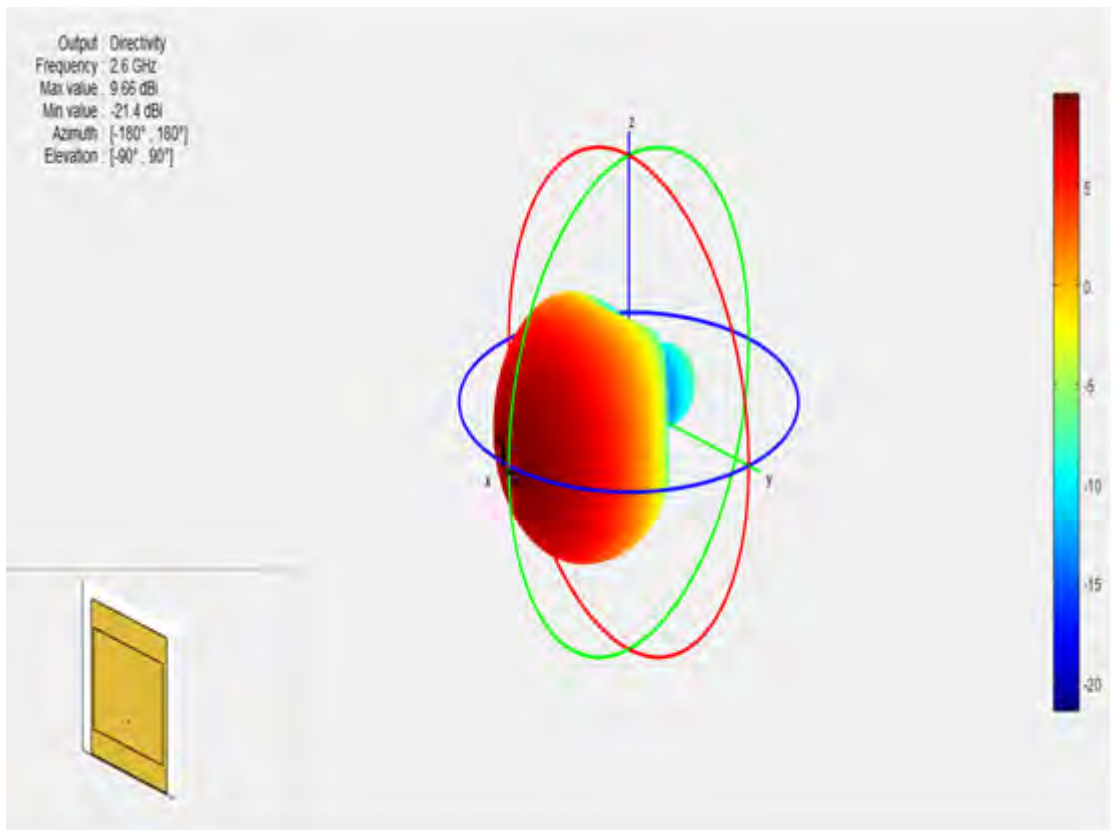

Figure 5.3: 3D directivity of rectangular patch array Antenna

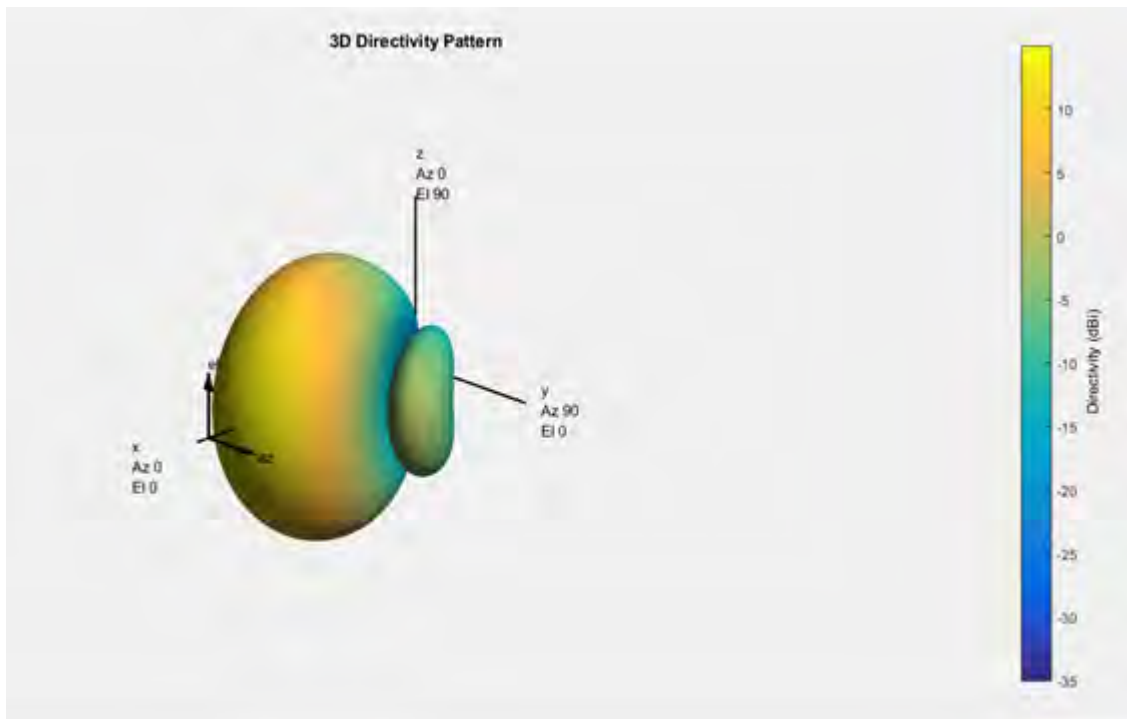

Figure 5.4: 3D directivity of cosine array Antenna element

As it is shown in Figure 5.3 and 5.4, the 3D far field plots of the antenna radiates in broadside direction with maximum directivity of 9.66dB and 17.6dB for rectangular micro strip patch array antenna and for cosine array antenna element respectively. From this we deduce that rectangular micro strip patch array antenna is not directive as compare to cosine antenna element. This is due to cosine antenna are ideal antenna element but as compare single micro strip patch antenna, more directive. As it is shown in Figure 5.5, Quarter-wave transformers ( $70\Omega$ )

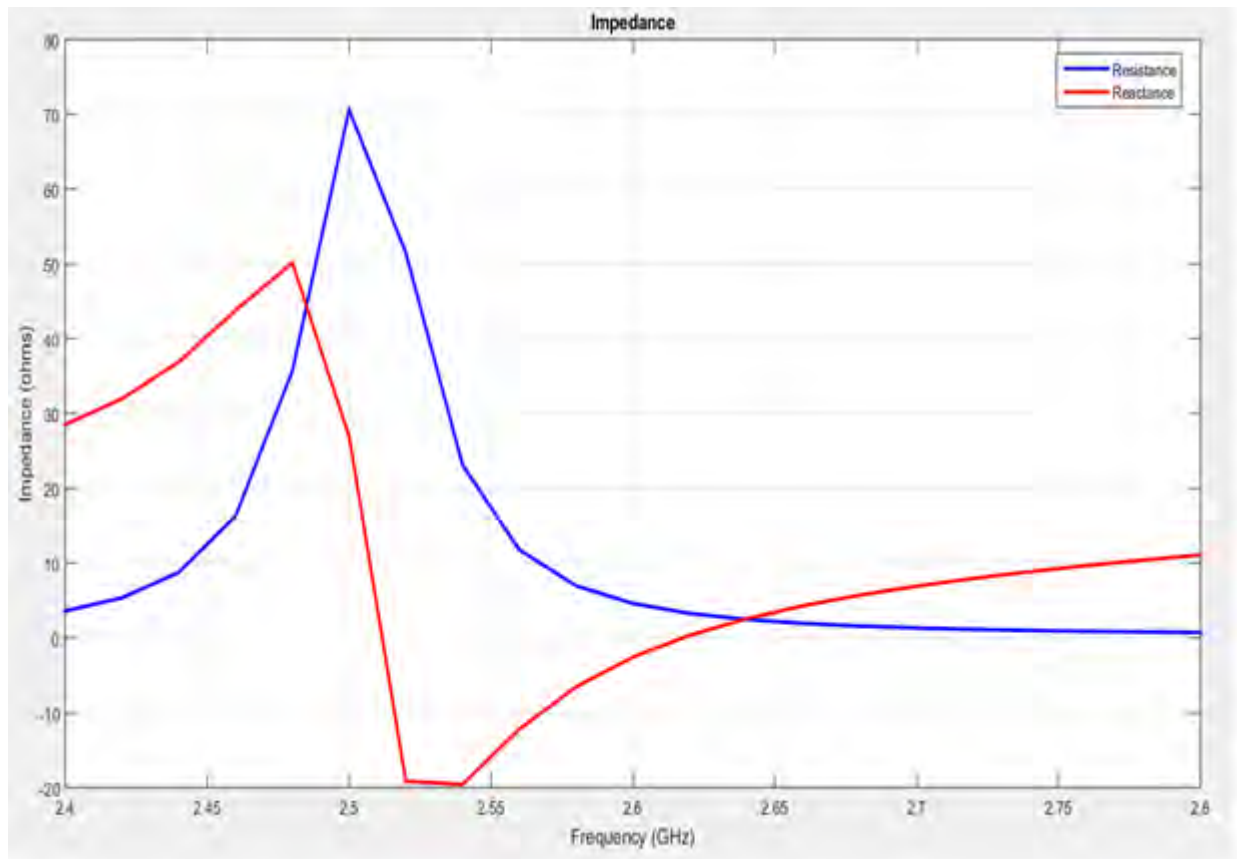

Figure 5.5: Input impedance characteristics of micro strip patch array antenna

are used to match the  $100\Omega$  lines to the  $50\Omega$  fed lines. The ratio of the voltage to current at the input terminals or Input impedance of antenna at input terminal  $Z_1 = 70\Omega$ . The patch is radiating in the correct mode with a pattern maximum at azimuth = elevation = 000 degrees. Since the some parameter dimensions are an approximation, its first resonance (parallel resonance) before the center frequency would mean than the impedance is real and the second resonance shift slightly from the center frequency. Our goal is to reduce the power reflected from the load (the antenna), and maximize the power delivered to the antenna.

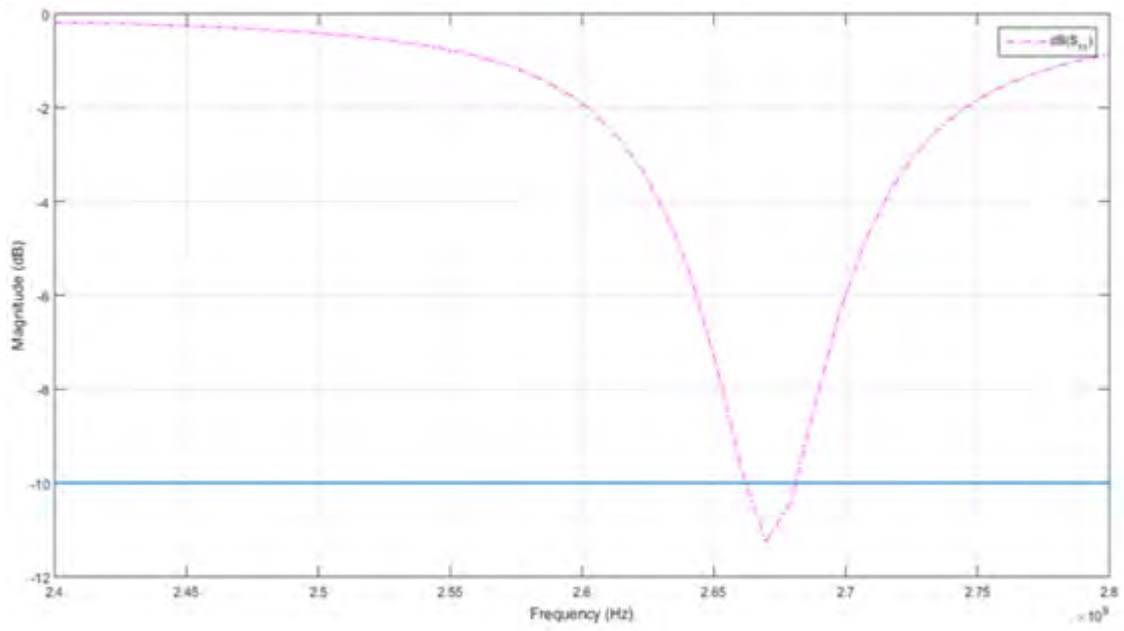

Figure 5.6:  $S_{11}$  (Return Loss) Parameter plot of rectangular patch array antenna for  $h=1.5\text{mm}$

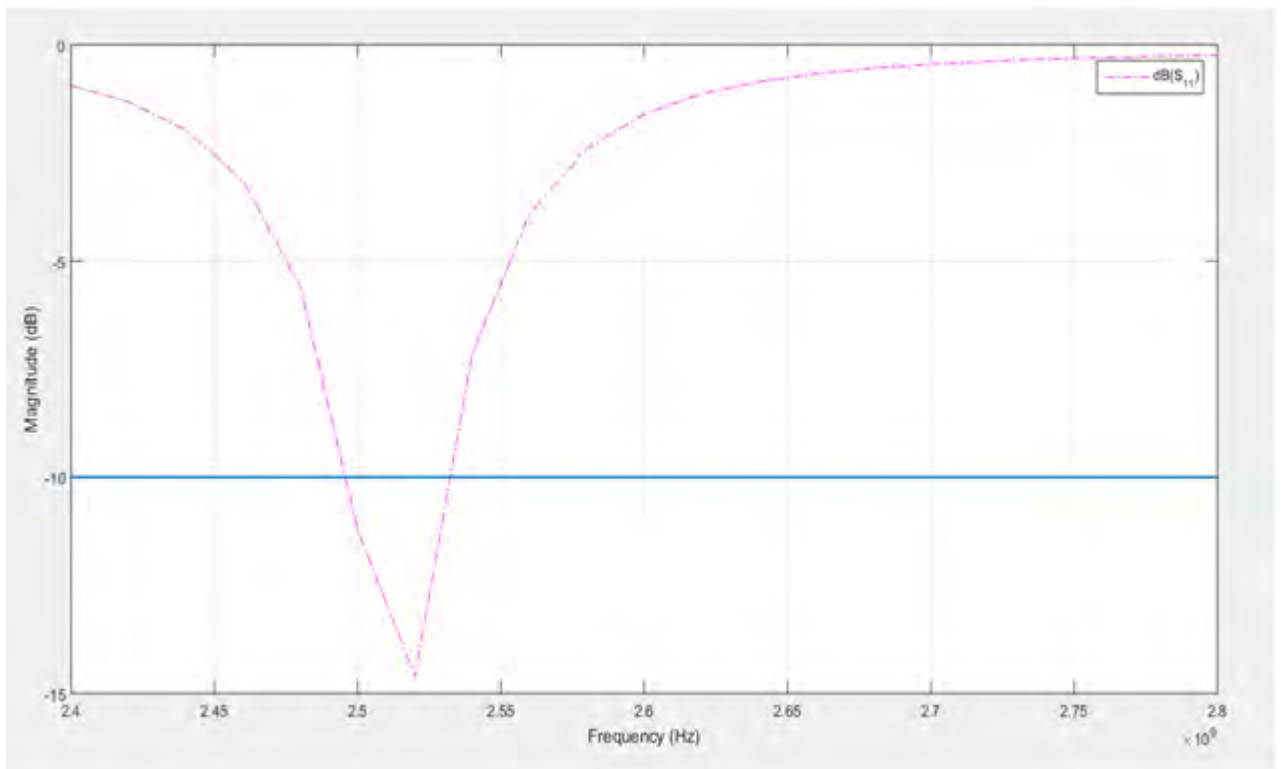

Figure 5.7:  $S_{11}$  (Return Loss) Parameter plot of rectangular patch array antenna for  $h=1.7\text{mm}$

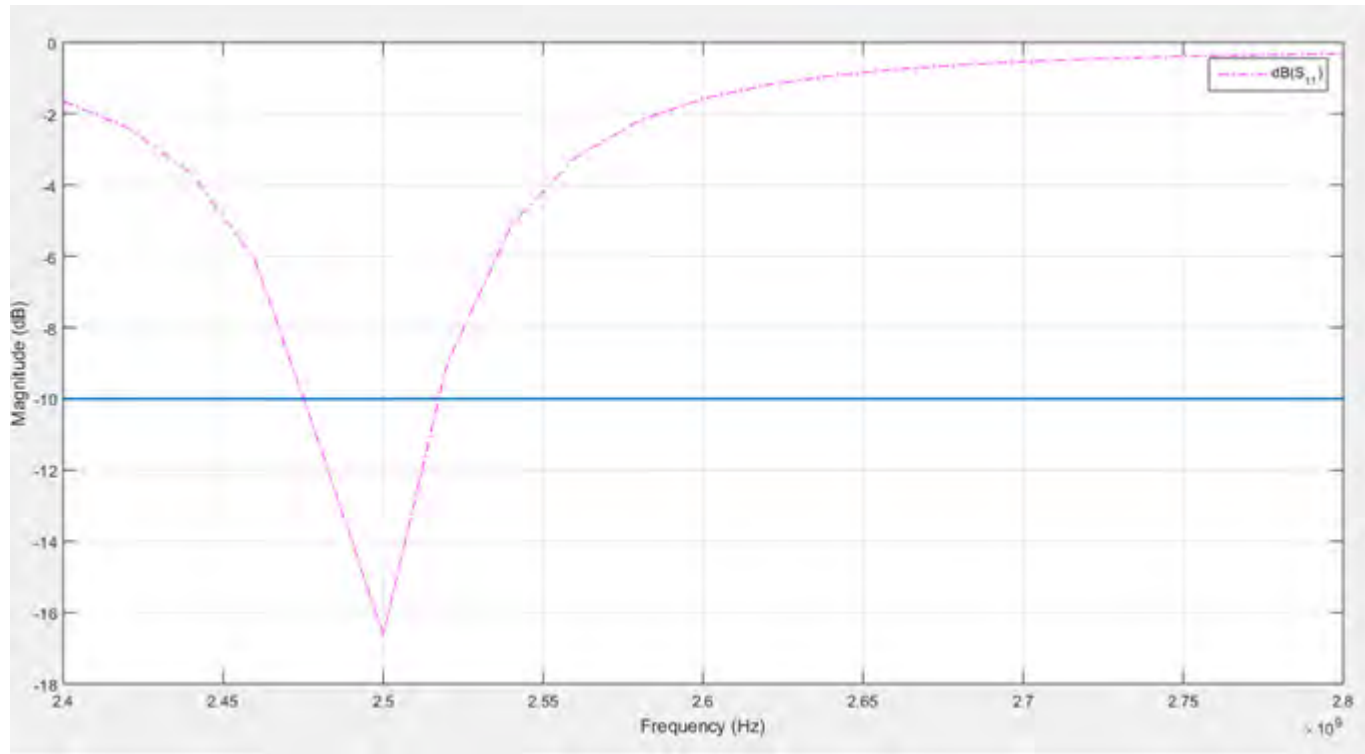

Figure 5.8:  $S_{11}$  (Return Loss) Parameter plot of rectangular patch array antenna for  $h=1.9\text{mm}$

During the development of designing the rectangular patch array antenna there is a response taken from the magnitude of magnitude (dB) versus frequency. This is known as the return loss. To have a perfect matching between the antenna and the transmitter,  $\Gamma = 0$  and  $RL = \infty$ , this indicates that there is no power that is returned or reflected but when  $\Gamma = 0$  and  $RL = 0\text{dB}$ , this indicated that the power that is sent is all reflected back. It is said that for the practical applications  $VSWR = 2$  is acceptable as the return loss would be  $-9.54\text{dB}$ . The reflection coefficient of the patch to confirm a good impedance match in our design is  $VSWR = 1.7$ . It is typical to consider the value  $S_{11} = -10\text{dB}$  as a threshold value for determining the antenna bandwidth. The deep minimum indicates a good match to  $50\Omega$ . As it is shown in Figure 5.6- Figure 5.8, the simulation of rectangular micro strip patch array antenna is taken for the same dielectric substrate with different substrate thickness.

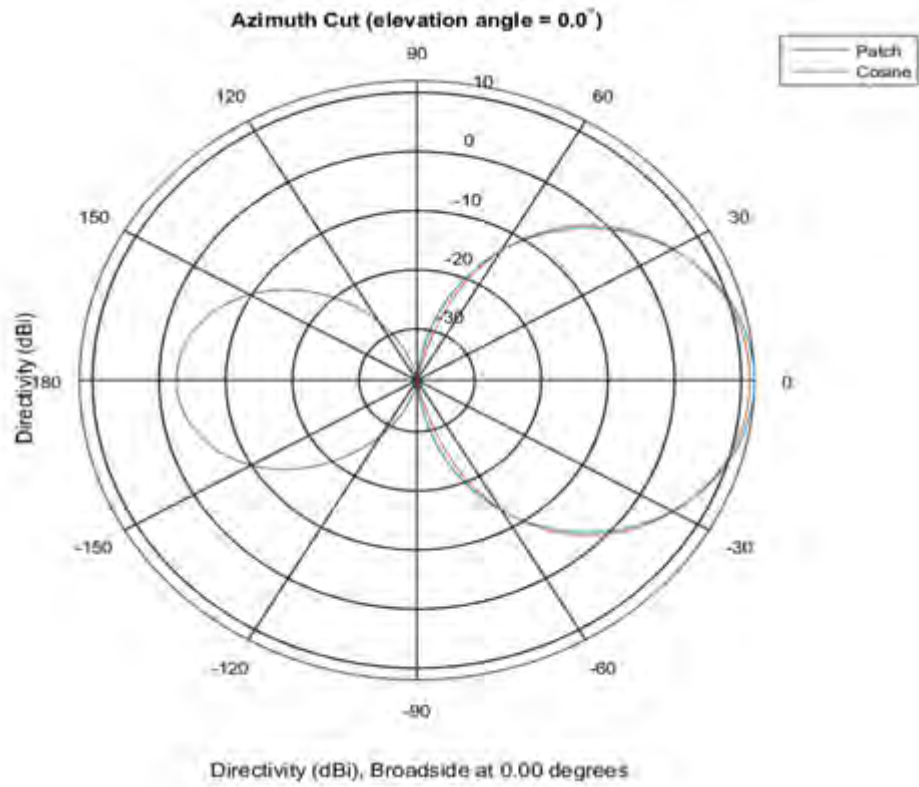

Figure 5.9: 3D radiation pattern with the array element space  $0.25(\lambda)$

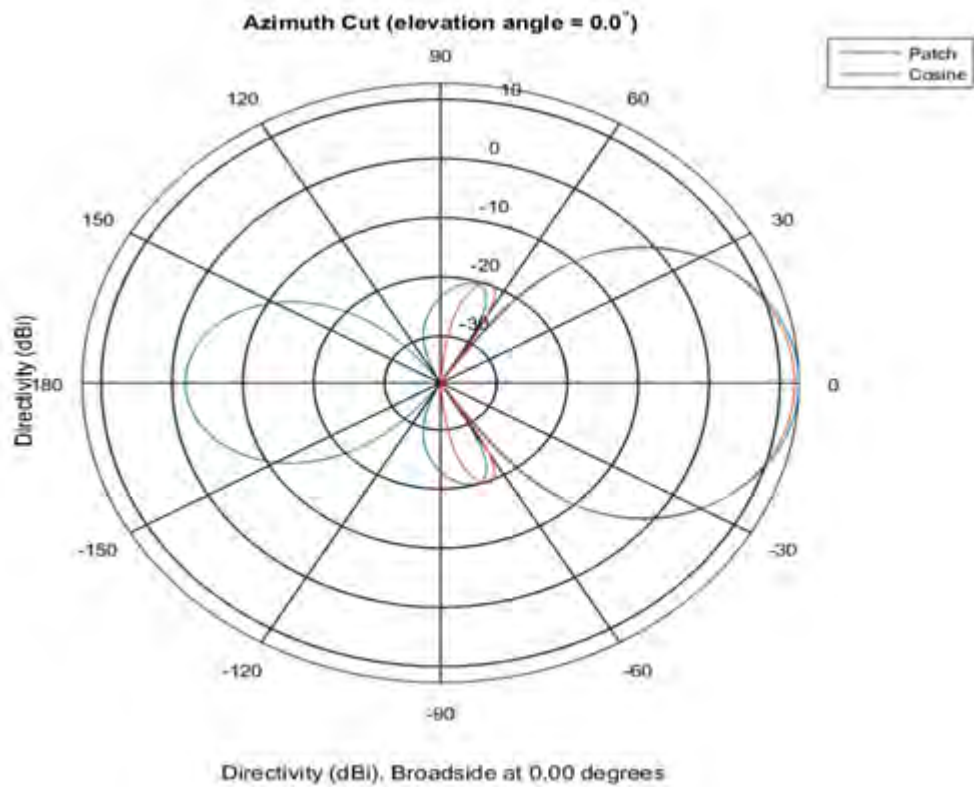

Figure 5.10: 3D radiation pattern with the array element space  $0.3(\lambda)$

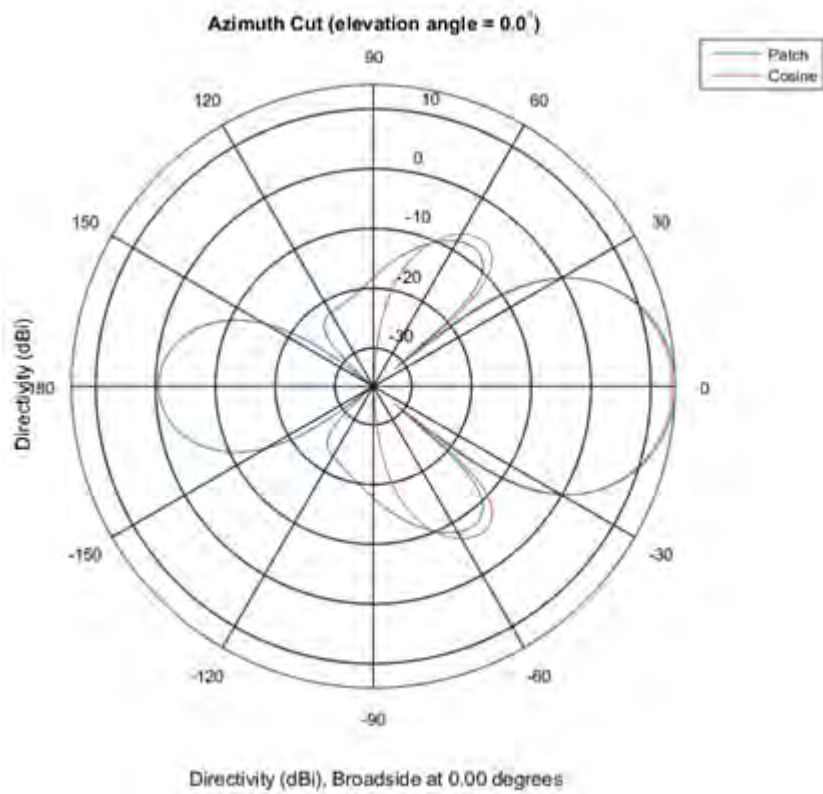

Figure 5.11: 3D radiation pattern with the array element space  $0.4(\lambda)$

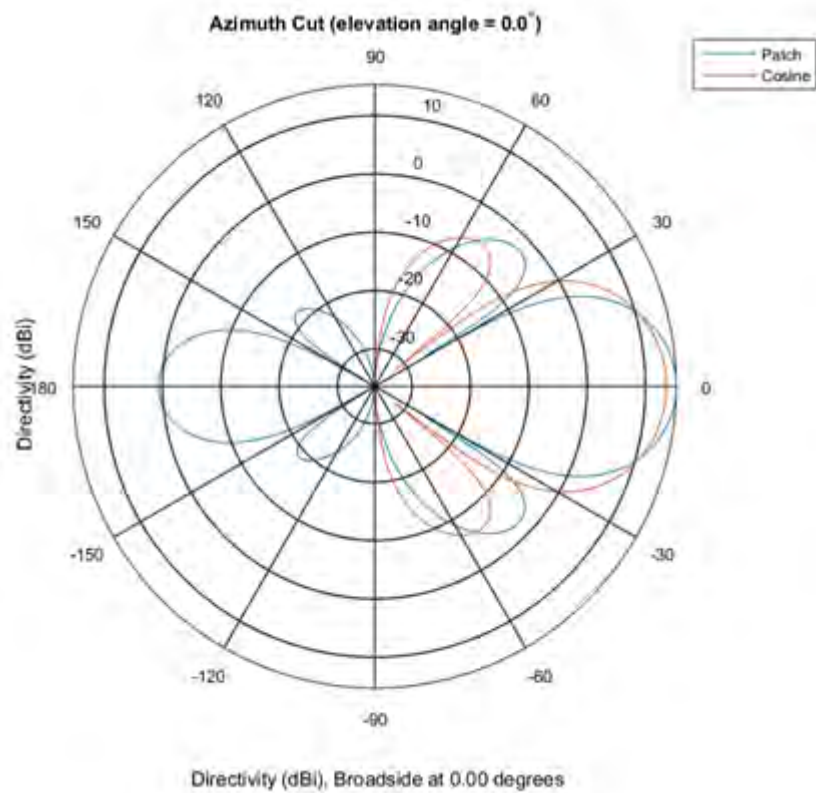

Figure 5.12: 3D radiation pattern with the array element space  $0.5(\lambda)$

As it is shown in Figure 5.9 -5.12, the 3D far field plots of the antenna radiates in broadside at 0.00 degree direction with maximum directivity of 9.66dB and some side lobe occur because of improper element spacing. To improve the return loss and reduce the side lobes inter-element spacing is used. The element spacing has a large influence on the array factor as well. If element spacing is greater than  $0.3\lambda$ , the side lobe is big and grating lobes occur. A grating lobe is another unwanted peak value in the radiation pattern of the array. If element spacing is less than  $0.3\lambda$ , mutual coupling effects occur. To avoid grating lobes and mutual coupling effects, the patch spacing for this design was chosen as  $0.3\lambda$ . In this thesis, 4x1 micro strip patch antenna array is designed for long term evolution with an equal spacing of  $0.3\lambda$ . The corporate feed method is used to excite the array elements. If the side lobe level is less than -10dB or -

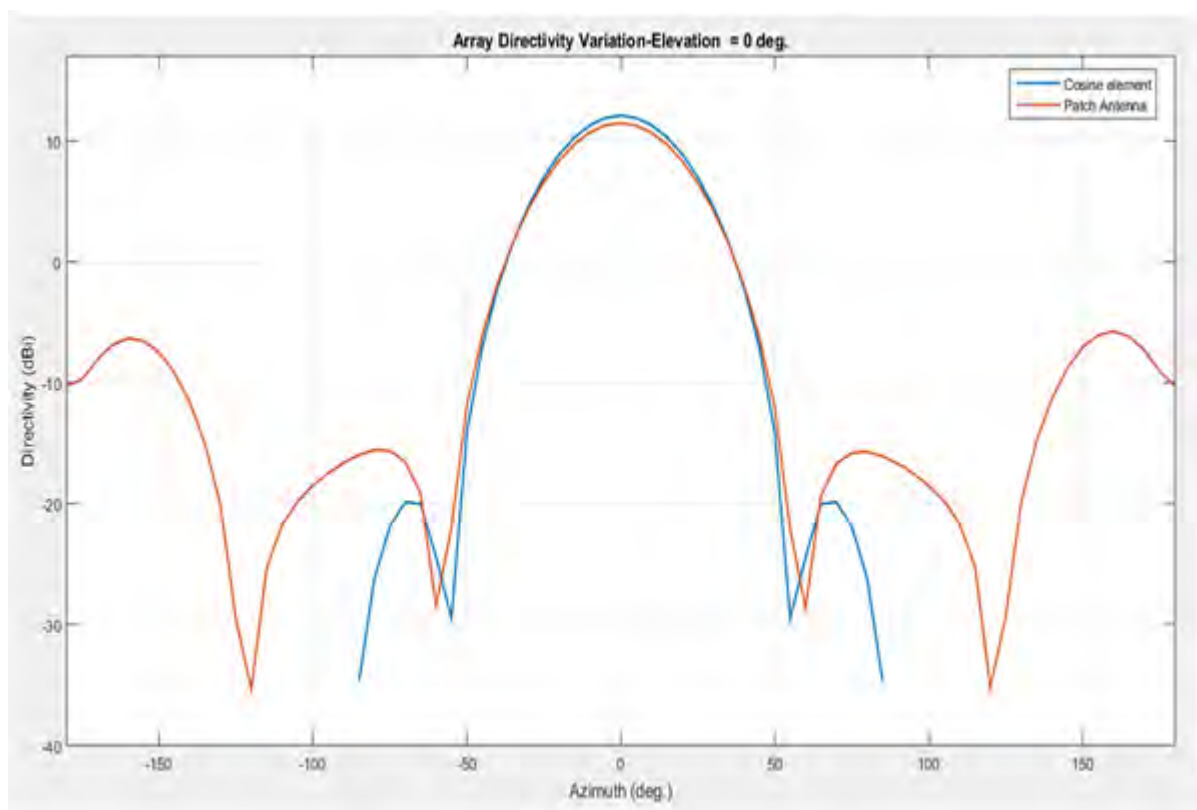

Figure 5.13: radiation pattern in to two orthogonal plane variation at elevation angle= $(00^0)$

15dB, the antenna performance is good. As it is shown In Figure5.13, we find that the side lobe level is -6dB. So the antenna performance is good.

# Chapter 6

## Conclusion and Future work

### 6.1 Introduction

This chapter concludes with a summary for this thesis and the future prospects of rectangular micro strip antenna array. The summary of thesis is discussed; the design perspective of both single patch and patch array antenna followed by performance analysis both antennas. Subsequently, the future work that is essential for this project to succeed, especially measurement and performance testing to validate the range met all the required specifications and exhibit excellent accuracy.

### 6.2 Conclusion

Rectangular micro strip antenna array has been developed for long term evolution (LTE). This thesis explained the theory behind micro strip antennas and a few explanations of the antenna arrays. Background information with regard to micro strip patch antenna arrays is demonstrated, followed by a literature review on micro strip antenna and how it can be implemented to benefits our application. In this section, we will highlight some of the unique properties of our design. A clear improvement of the radiation efficiency and patterns of micro strip antennas on high dielectric-constant substrates (FR4) has been demonstrated, resulting from a local reduction of the substrate dielectric constant underneath the antenna patches using micro strip feed line techniques. As expected, the designed micro strip antenna array resulted in high efficiency, wide bandwidth and good radiation pattern. Whereas the use of rectangular patch geometry provided good directivity and simplicity in design process. Based on the simulations obtained in chapter 5, the micro strip antenna arrays have been successfully explained and centered at 2.6 GHz frequency using MATLAB, carrying an optimization to the geometry, resulted in further improvement of the simulation parameters. The computer simulation for this antenna array has showed a pretty directivity with up to 9.66 dBi and the  $S_{11}$  parameter for all the antenna arrays have a magnitude of much less than -10dB at the operating frequency 2.6 GHz, which means that those antennas doesn't have many losses while transmitting the signals. As for the voltage standing wave ratio (VSWR), it is not ideal; however, we obtained a value of under 2 which is consider acceptable and the level of mismatch is not

high. The antenna arrays bandwidth was determined from  $S_{11}$  parameter below the threshold -10dB. Clearly, the antenna bandwidth of the compact design with less number of elements is reduced. This is to be expected owing to the antenna size reduction.

### **6.3 Future Work**

A Micro strip Line fed Rectangular Micro strip Patch Antenna with the dimension parameters h-1.6mm, L- 24.256mm, W- 34.2mm with a dielectric constant of 4.4 at an operating frequency of 2.6GHz from this project can be said as the optimized design. It is very important to take the feed technique the impedance and the substrate is the main parameters into consideration. The proper position to terminate the Feed line also affects the performance of the antenna. As said different type of feed technique affects the performance of the antenna. Micro strip feed line is shown in this thesis and the results implies the performance of the antenna is good. In future other different type of feed techniques can be used to evaluate the overall performance of the antenna without missing the optimized parameters in the action. Extensively and exclusively focusing on the area of different design methods especially in minimizing the mutual coupling between the elements. Besides, they can also use different shapes of micro strip patches such as square, circular and hexagonal shape to carry out the research. Finally we want recommend; they can carry out the research by increase the array element in order to enhance the performance of the patch antenna.

# Bibliography

- [1] Constantine A. Balanis, *Antenna Theory Analysis and Design*, 3rd edition, New Jersey, John Wiley and sons Inc, 2005.
- [2] Lars Josephson and Patrick Person, *Conformal Array Antenna Theory and Design*, International Electrical and Electronics Engineering Antennas and Propagation Society, Sponsor, John Wiley and Sons, Ltd., Hoboken, New Jersey, 2006.
- [3] Rajesh warLalDua, Himanshu Singh "2.45 GHz Micro strip Patch Antenna with Defected Ground Structure for Bluetooth," *International Journal of Soft Computing and Engineering*, ISSN: 2231 – 2307, Volume 1, no.4, January 2012.
- [4] Alak Majumder, "Design of an H-shaped Micro strip Patch Antenna for Bluetooth Applications," *International Journal of Innovation and Applied Studies*, Vol. 3 , No. 4, ISSN 2028 – 9324, pp. 987 – 994 , Aug. 2013.
- [5] A. K. Arya, A. Patnaik, M. V. kartikeyan, "Gain Enhancement of Micro-strip patch antenna using Dumbbell shaped Defected Ground Structure," *International Journal of Scientific Research Engineering Technology*, Volume 2 Issue4 ,ISSN 2278 – 0882, pp 184 – 188, July 2013,
- [6] Sakshi Kapoor, Davinder Parkash, "Efficient Micro strip Fed Rectangular Patch Antenna with DGS for WLAN WiMAX Applications," *International Journal of Engineering Research and Applications*, Vol. 2, Issue 6, pp.044 – 047, November - December 2012.
- [7] Bharti Gupta, Sangeeta Nakhate, Madhu Shandilya, "Compact Ultra Wideband Micro strip Antenna with Modified Ground Plane for Bandwidth Enhancement," *International Journal of Computer Applications* Volume 49, S No.19, pp.0975 – 1087, July 2012.
- [8] Neha Ahuja, Rajesh Khanna and Jaswinder Kaur Kaur, "Design of single band Rectangular micro strip patch antenna for WLAN application," *International Journal of computer application*, Vol. 3 , No. 4, ISSN 2028 – 9324 , pp. 987 – 994 , Aug. 2012.
- [9] Ashish Kumar, "RMPA Using L slot structure", *Journal of Research in Electrical and Electronics Engineering*, Volume 2, Issue 2, pp.044 – 0624, March 2013.

- [10] Rahul Tiwari, "Design and simulation of Rectangular micro strip patch antenna for wireless communication," *Journal of Research in Electrical and Electronics Engineering*, Volume 2, Issue 1, ISSN: 2321 – 2667, Jan. 2013.
- [11] P. V. Lokhande, B. T. Salokhe, "Design Simulation of Circular Micro strip Antenna with Defected Ground Structure (DGS) for WLAN Application," *International Journal of Electrical and Computer Engineering*, Volume 5, Issue 1, ISSN: 2278 – 2834, Jan. 2013.
- [12] Mouloud Challal, Arab Azrar and Mokrane Dehmas, "Rectangular Patch Antenna Performances Improvement Employing Slotted Rectangular shaped for WLAN Applications," *IJCSI*, Vol. 8, Issue 3, No. 1, May 2011.
- [13] Ashish Kumar, BimalGarg, "Rectangular Micro strip Patch Antenna Loaded With Double Orthogonal Crossed Slits In Ground Plane," *International Journal of Advance Technology Engineering Research*, Vol. 4, Issue 3, No. 1, June 2011.
- [14] Asad'ullah'Noor "micro strip patch antenna for GSM and Wi-Max application," *International Journal of Electrical and Computer Technology*, Vol. 2, Issue 4, Oct-Dec 2013.
- [15] Mohammad Akbari, Jafar Khalilpour, Mojtaba Mighani, Saeed Rastgar "A Novel Compact Printed Antenna using Defected Ground Structure for 2.4 and 5 GHz Communication," *IJECT*, Vol. 2, Issue 4, Oct-Dec 2011.
- [16] Huda A. Majid, M. Kamal A. Rahim, M. Rijal Hamid, and M. F. Ismail "A Compact Frequency- Reconfigurable Narrowband Micro strip Slot Antenna," *IEEE*, Vol. 2, Issue 4, Dec 2015.
- [17] Ashwini K. Arya, M. V. Kartikeyan, A Patnaik, "Defected Ground Structure in the perspective of Micro strip antenna," *IJATER*, Vol.64, Issue5 – 6, pp.79 – 84, Oct 2010.
- [18] Neha Ahuja, Rajesh Khanna, Jaswinderkaur "Dual Band Defected Ground Micro strip Patch Antenna for WLAN / WiMAX and Satellite Application," *International Journal of Computer Applications*, Volume 48, S No.22, Issue 3, June 2012.
- [19] Neha Chavda, Dr. Vedvyas Dwivedi, DrKiran Parma, "Designing of Micro strip Patch Antenna For 3G-WCDMA Applications," *IJATER*, Vol.14, Issue5 – 6, pp.79 – 84, Oct 2011.
- [20] Girish Kumar, K. P. Ray *Broadband Micro strip Antennas*, 2nd, ArtechHous Boston - London, ISBN: 1-58053-244-6, 2003.

- [21] Rabia Zainab Syeda "Design and Performance Analysis of Switched Beam Series-Fed Patch Antenna Array for 60 GHz WPAN Applications," *International Journal of Advance Technology Engineering Research*, Vol. 4, Issue 3, No. 1, June 2014.
- [22] D. Pozar and D. Schaubert, "Micro strip Antennas: The Analysis and Design of Micro strip antennas and Arrays," *Wiley IEEE express*, Vol. 4, Issue 3, No. 1, June 2016.
- [23] A. Benalla and K. C. Gupta, "Design of a Low Side Lobe Short Series-Fed Linear Array of Micro strip Patches" *Electromagnetic Laboratory Scientific Report, University of Colorado* No. 93, October 2007.
- [24] Amna Ikram "Design and development of a multiband loop antenna for cellular mobile handsets," *International Journal of Advance Technology Engineering Research*, 2010.
- [25] Yun-Wen Chi and Kin-Lu Wong, "Small-Size Multiband Folded Loop Antenna for Small-Size Mobile Phone", *presented at International Electrical and Electronics Engineering Antennas and Propagation Society International Symposium*, San Diego, CA, Jul. 2008.

# Appendix A

## appendix

### Appendix A.1 : Derivation of Conductance

Each radiating slot is represented by a parallel equivalent admittance  $Y$  (with conductance  $G$  and susceptance  $B$ ). The slots are labeled as 1 and 2. The equivalent admittance

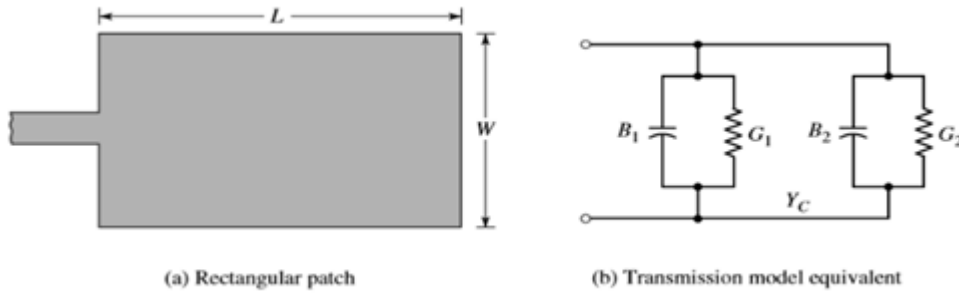

Figure A.1: Rectangular micro strip patch and its equivalent circuit transmission-line model

of slot 1, based on an infinitely wide, infinite slot, is given by:

$$Y_1 = G_1 + jB_1 \quad (\text{A.1})$$

Where for a slot of finite width  $W$

$$G_1 = \frac{W}{120\lambda_0} \left[ 1 - \frac{1}{24} (k_0 h)^2 \right] \text{ for } \frac{h}{\lambda_0} < \frac{1}{10} \quad (\text{A.2})$$

$$B_1 = \frac{W}{120\lambda_0} [1 - 0.636 \ln(k_0 h)] \text{ for } \frac{h}{\lambda_0} < \frac{1}{10} \quad (\text{A.3})$$

Since slot 2 is identical to slot 1, its equivalent admittance is:

$$Y_2 = Y_1, G_2 = G_1, B_2 = B_1 \quad (\text{A.4})$$

In general, the conductance is defined as:

$$G_1 = \frac{2P_{rad}}{|V_0|^2} \quad (\text{A.5})$$

he radiated power is written as:

$$P_{rad} = \frac{|V_0|^2}{2\pi_0} \int_0^\pi \left[ \frac{\sin \frac{K_0 W}{2} \cos \theta}{\cos \theta} \right]^2 \sin^3 \theta d\theta \quad (\text{A.6})$$

Asymptotic values of the conductance for radiating patch is:

$$G_1 = \frac{1}{90} \left[ \frac{W}{\lambda_0} \right]^2 \text{ for } W \ll \lambda_0 \text{ and } G_1 = \frac{1}{120} \left[ \frac{W}{\lambda_0} \right]^2 \text{ for } W \gg \lambda_0 \quad (\text{A.7})$$

## Appendix A.2 : Resonant Input Resistance

The total admittance at slot 1 (input impedance) is obtained by transferring the admittance of slot 2 from the output terminals to the input terminals using the admittance transformation equation of transmission lines. Ideally the two slots should be separated by  $\frac{\lambda}{2}$  where  $\lambda$  is the wavelength in the dielectric (substrate). However, because of fringing the length of the patch is electrically longer than the actual length. Therefore the actual separation of the two slots is slightly less than  $\frac{\lambda}{2}$ . If the reduction in length is properly chosen (typically  $0.48\lambda < L < 0.49\lambda$ ), the transformed admittance of slot 2 becomes:

$$Y_2 = G_2 + jB_2 = G_1 - jB_1 \quad (\text{A.8})$$

$$G_2 = G_1, B_2 = -B_1 \quad (\text{A.9})$$

Therefore the total resonant input admittance is real and is given by:

$$Y_{in} = Y_1 + Y_2 = 2G_1$$

Since the total input admittance is real, the resonant input impedance is also real, or

$$Z_{in} = \frac{1}{Y_{in}} \text{ and } R_{in} = \frac{1}{2G_1} \quad (\text{A.10})$$

If resonant input resistance, does not take into account mutual effects between the slots.

This can be accomplished to :

$$R_{in} = \frac{1}{G_1 + G_{12}} \quad (\text{A.11})$$

Where the plus (+) sign is used for modes with odd (anti symmetric) resonant voltage distribution beneath the patch and between the slots while the minus (-) sign is used for modes with even (symmetric) resonant voltage distribution. The mutual conductance is defined, in terms of the far-zone fields, as

$$G_{12} = \frac{1}{|V_0|^2} \Re \int \int_s E_1 \times H_2^* \cdot ds \quad (\text{A.12})$$

Where  $E_1$  is the electric field radiated by slot 1,  $H_2$  is the magnetic field radiated by slot 2,  $V_0$  is the voltage across the slot, and the integration is done over a sphere of large radius. It can be shown that  $G_{12}$  can be calculated using:

$$G_{12} = \frac{|V_0|^2}{120\pi^2} \int_0^\pi \left[ \frac{\sin \frac{K_0 W}{2} \cos \theta}{\cos \theta} \right]^2 J_0(K_0 L \sin \theta) \sin^3 \theta d\theta \quad (\text{A.13})$$

Where  $J_0$  is the Bessel function of the first kind of order zero? As shown by above the input resistance is not strongly dependent upon the substrate height  $h$ . In fact for very small values of  $h$ , such that  $K_0 h \ll 1$ , the input resistance is not dependent on  $h$ . Modal-expansion analysis also reveals that the input resistance is not strongly influenced by the substrate height  $h$ . It is apparent that the resonant input resistance can be decreased by increasing the width  $W$  of the patch. This is acceptable as long as the ratio of  $W/L$  does not exceed 2 because the aperture efficiency of a single patch begins to drop, as  $W/L$  increases beyond 2. The resonant input resistance, as calculated by (1-17), is referenced at slot 1. However, it has been shown that the resonant input resistance can be changed by using an inset feed, recessed a distance  $y_0$  from slot 1, as shown in Figure A.1.

## Appendix B.1 : Sample MATLAB Code

### % designing and simulation initialization code

Most of MATALAB source code for carrying out this simulation taken from mat works by substitutes our simulation parameter.

```
fc = 2.6e9; \% initialization the frequency
fmin = 2.4e9;
fmax = 2.8e9;
vp = physconst('lightspeed');
lambda = vp/fc;
cosineElement = phased.CosineAntennaElement; \% intialization of cosine phase array
cosineElement.FrequencyRange = [fmin fmax];
cosinePattern = figure;
pattern(cosineElement,fc) \% the single cosine element of the antenna
Nrow = 1;
Ncol = 4; \% 4x1 element of cosine array
msCosineArray = phased.URA;
msCosineArray.Element = cosineElement;
msCosineArray.Size = [Nrow Ncol];
msCosineArray.ElementSpacing = [0.3*lambda 0.3*lambda];
cosineArrayPattern = figure;
pattern(msCosineArray,fc); \%the radaition pattern of 4x1 cosine array
\%patchElement = patchMicrostrip('Length',24.2e-3, 'Width',34.256e-3, \
\%'GroundPlaneLength',60e-3, 'GroundPlaneWidth',60e-3,'feedOffset',[11e-6,11e-6]);\
\%patchElement.FrequencyRange = [fmin fmax];
\%patchPattern = figure;
patchElement = patchMicrostrip; \% single patch element intialization.
patchElement.Length = 0.42*lambda; \% the patch length is 0.42*lamda which is 0.42 times
the default length.
patchElement.Width = 1.4*patchElement.Length;\% the patch width is 1.4*the patch length
patchElement.GroundPlaneLength = 0.75*lambda;\% the ground plane length three-fourth of the default ground plane le
patchElement.GroundPlaneWidth = 0.75*lambda; \% the ground plane width three-fourth of the \
default ground plane width
patchElement.Height = 0.01*lambda; \% the patch antenna hieght
patchElement.FeedOffset = [patchElement.Length/4 0]; \%the feed off set of the patch element\
or the inset feed of the patch
\%feedOffset=Z,[11e-6,11e-6]);\% this vector can calculated from some bassel function.
\%vswr (patchElement,1.8e9:0.5e7:2.8e9,50)\% VSWR calculation
Nrow = 1;
Ncol = 4;
patchArray = phased.URA; \% intialization of patch array as uniform rectangular phased array
patchArray.Element = patchElement;
patchArray.Size = [Nrow Ncol];
patchArray.ElementSpacing = [0.3*lambda 0.3*lambda]; \% the elment spacing between the array elemment
patchArrayPattern = figure;
patchElement.Length = 0.42*lambda; \% the individual patch length is 0.42*lamda which is 0.42 times\
\%the default length.
patchElement.GroundPlaneLength = 0.75*lambda;\% he ground plane length three-fourth of the default \%ground plane le
```

```

patchElement.GroundPlaneWidth = 0.75*lambda;% the ground plane width three-fourth of the default ground plane width
patchElement.Height = 0.01*lambda; %the individual patch antenna height.
patchElement.FeedOffset = [patchElement.Length/4 0]; %the individual element feed offset of the patch or the inset
%feedOffset=Z,[11e-6,11e-6]);% this vector can be calculated from some bessel function.
patchElement.Tilt = 90;
patchElement.TiltAxis = [0 1 0];
figure
show(patchElement)
axis tight
view(140,20)
pattern(patchArray,fc) % the overall pattern of the array
pattern(patchElement,fc) % the element pattern of the array
Numfreqs = 21; % the number of frequency that sweep during the plot of input impedance and return loss.
freqsweep = unique([linspace(fmin,fmax,Numfreqs) fc]);
impedance(patchElement,freqsweep);% plot of impedance matching.
resonance=2.64e9;
lambda_act = vp/resonance;
scale = lambda/lambda_act;% scale factor that take exact resonance in impedance matching plot
patchElement.Length = scale*patchElement.Length;
s = sparameters(patchElement,freqsweep);
figure
rfplot(s,'m-.')% the rf plot of return loss
hold on
line(freqsweep,ones(1,numel(freqsweep))*-10,'LineWidth',1.5)
hold off
pattern(patchElement,2.6e9);
fc2 = 2.6e9;
lambda_fc2 = vp/2.6e9;
msPatchArray = phased.URA;
msPatchArray.Element = patchElement;
mswPatchArray.Size = [Nrow Ncol];
msPatchArray.ElementSpacing = [0.5*lambda_fc2 0.5*lambda_fc2]; %the element space of the array
az = -180:5:180; % the phase scanning of the array in the azimuth direction in five difference
el = -90:5:90; % the phase scanning of the array in the elevation direction in five difference
clf;
pattern(fmcwPatchArray,fc,az,el); % the 3D pattern of the array in both direction.\\
hold on;
patternAzimuth(CosineArray,fc);
legend('Patch','Cosine','Location','NorthEastOutside');
[Dcosine_az_zero,~,eln] = pattern(CosineArray,fc,0,el);
[Dcosine_el_zero,azn] = pattern(CosineArray,fc,az,0);
[Dpatch_az_zero,~,elp] = pattern(PatchArray,fc,0,el);
[Dpatch_el_zero,azp] = pattern(PatchArray,fc,az,0);
elPattern = figure;
plot(eln,Dcosine_az_zero,eln,Dpatch_az_zero,'LineWidth',1.5) % the 3D plot of the radiation pattern \\of both the
axis([min(eln) max(eln) -40 17])
grid on
xlabel('Elevation (deg.)')
ylabel('Directivity (dBi)')
title('Array Directivity Variation-Azimuth = 0 deg.')
legend('Cosine element','Patch Antenna','Location','best')
azPattern = figure;

```

```
plot(azn,Dcosine_el_zero,azn,Dpatch_el_zero,'LineWidth',1.5) \% the 2D orthogonal plot of the radiation pattern of
axis([min(azn) max(azn) -40 17])
grid on
xlabel('Azimuth (deg.)')
ylabel('Directivity (dBi)')
title('Array Directivity Variation-Elevation = 0 deg.')
legend('Cosine element','Patch Antenna','Location','best')
```