



Addis Ababa University
Addis Ababa Institute of Technology
School of Mechanical and Industrial Engineering
Manufacturing Engineering Stream

**Fabrication and evaluation of mechanical properties of the
hybrid coffee husk and Enset fiber-epoxy reinforced
composites.**

A Thesis Submitted to the Graduate School of Addis Ababa University
in Partial Fulfillment of the Requirement for the Degree of Masters of
Science in Mechanical Engineering. (Manufacturing Engineering)

By: Shambel Dibaba
Advisor: Dr. Desalegn Wogaso

June, 2023
Addis Ababa, Ethiopia

Addis Ababa University
Addis Ababa Institute of Technology

School of Mechanical and Industrial Engineering

**FABRICATION AND EVALUATION OF MECHANICAL
PROPERTIES OF THE HYBRID COFFEE HUSK AND ENSET
FIBER-EPOXY REINFORCED COMPOSITES.**

By: Shambel Dibaba

Approved By; Board Of Examiners

Dr. Desalegn Wogaso

Advisor

Signature

Date

Internal Examiner

Signature

Date

External Examiner

Signature

Date

Chairman of the school

Signature

Date

DECLARATION

Addis Ababa University
School of Graduate Studies

This is to declare that the thesis prepared by **Shambel Dibaba Daba**, entitled: *Fabrication and evaluation of mechanical properties of the hybrid coffee husk, Enset fiber-epoxy reinforced composites*, I thus declare that this thesis is my preliminary work and that it has not been submitted in part or in whole for an academic degree at any university/institution, and that it adheres with the university's requirements and fulfills the acknowledged criteria for authenticity and consistency.

Name: Shambel Dibaba Daba

Place: Addis Ababa, Ethiopia

Signature: _____

Date: _____

Advisor's signature

Advisor: Dr. Desalegn Wogaso; Signature: _____ Date: _____

Acknowledgments

First and foremost, I am thankful to the supreme GOD for offering me the ability to finish this study. Furthermore, I want to show my heartfelt appreciation to my advisor, Dr. Desalegn Wogaso, Assistant Professor, School of Mechanical and Industrial Engineering, for his inspiring and considerate consultation, patience, and invaluable assistance from the start to the finish of the project. I will be eternally grateful for the assistance, guidance, and encouragement that greatly aided my thesis writing. I will be thanks fully to my parents and my wife Mss. Merhawit Bonsel for her support and her love in my life. Finally, I'd like to thank Wondu Tesfaye, Israel, Faysel, and all of my classmates for patiently providing me with all of the encouragement I needed to achieve my goals.

Abstract

in modern times there is a growing concern about replacing polluting and not recyclable synthetic fibers, as well as rare wooden fibers, with sustainable lignocellulose fibers derived from agricultural leftovers for reinforcement bio-composites. Currently in Ethiopia, the accident rate of vehicles on the road is increasing. Along with that, Vehicle security is a significant topic of study to safeguard. not only structures but also occupants in the event of a crash. In the other side the fast increase of population and development of cities required demand for transport, hence to full fill the demand recently the vehicles are imported in large amounts at the same time which requires accessory's for replacement of their parts, so the front bumper of those vehicle is the most parts demanded due to it is the most exposed part during crash. The Enset fiber and coffee husk were collected from Ethiopia's Southern Nations, Nationalities, and People's Region (SNNPR) Gedeo zone, Yirgachefe district. Sun-dried Eset and coffee husk were treated with a 5% sodium hydroxide mixture to remove more cellulose, hemicellulose, lignin, and additional fiber chunks to increase binding and facial shear strength. Following that, Enset-coffee husk fibers reinforced hybrid composite was created utilizing a hand layup method on the 40-60%, 30-70%, and 20-80% fiber weight percentages of matrix weight to total fiber volume. Tensile, compressive, its impact, flexural, and absorbance of water tests were then performed to determine which constituent of the composite had higher strength under load. While the mechanical and physical properties of the composites were assessed, the composite C5 with E20%-CH10%-E70% possessed the best mechanical and physical properties, with a tensile strength of 43.30MPa, flexural strength of 93.38 MPa, compression strength of 21.23MPa, impact energy of 3.5J, and water absorption percentage of 3.55%. In addition, the front bumpers was modeled in ANSYS 19.2 and composite C5, yielding an optimal von missed stress of 39.119MPa and distortion of 15.09mm. According to the findings and analyses, the chosen Enset-Coffee husk-Epoxy hybrid composite might be explored subsequently as a low-speed crash replacement material for the front bumper.

Key word: Front Bumper, Tensile strength, Flexural Strength, Compression strength, coffee husk, Enset.

List of abbreviation and acronyms

ANSI	American National Standards Institute
ASTM	American Society of Testing and Materials
CH	Coffee husk
E	Epoxy
E	Modulus of elasticity (Mpa)
EF	Enset fiber
Eq	Equation
ϵ	Strain (mm/mm)
m	Meter
mm	Millimeter
NaOH	Sodium hydroxide
PP	Polypropelyn
PVAc	Polyvinyl acetate
t	Thickness (mm)
UTM	Universal Testing Machine
V 'm	Volume fraction of matrix (%)
V' f	Volume fraction of fiber (%)
WA	Water absorption
WC	Weight of composite (g)
Wf	Weight of fiber (g)

W_m	Weight of a matrix (g)
W_{pyc}	Weight of Pycnometer (g)
ρ_c	Density of composite (g/cm ³)
ρ_f	Density of fiber (g/cm ³)
ρ_m	Density of matrix (g/cm ³)
σ	Stress (Mpa)
v_c	Volume of composite (cm ³)
v_f	Volume of fiber (cm ³)
v_m	Volume of a matrix (cm ³)

Table of Contents

Acknowledgments.....	i
Abstract.....	ii
List of abbreviation and acronyms.....	iii
Table of Contents.....	v
List of figures.....	x
Chapter One.....	1
Introduction.....	1
1 Background of the Study.....	1
1.1 Problem of Statement.....	3
1.2 Objective.....	4
1.2.1 General objective.....	4
1.2.2 Specific objectives.....	4
1.3 Research Questions.....	5
1.4 Scope of the study.....	5
1.5 Limitations of the Study.....	5
1.6 Organization of the Study.....	5
Chapter Two.....	7
Literature Review.....	7
2 Composite Materials.....	7
2.1 Development of Composites.....	8
2.2 Classification of composite.....	10
2.2.1 Classification based on matrix material.....	10
2.2.2 Metal Matrix Composite.....	10
2.2.3 Ceramic Matrix Composite.....	11

2.2.4	Polymer Matrix Composite	11
2.3	Reinforcement Material	12
2.3.1	Fiber Reinforced Composite	13
2.3.2	Particle Reinforced Composite.....	13
2.3.3	Whisker Reinforced Composite	14
2.3.4	Structural Reinforced Composite.....	14
2.4	Matrix Material	15
2.4.1	Thermosetting Resins	15
2.4.2	Thermoplastics Resins.....	15
2.4.3	Epoxy	16
2.5	Fibers.....	17
2.5.1	Types of Fibers.....	18
2.5.2	Natural Fibers.....	18
2.6	The Need for Hybrid Composites	21
2.7	Enset/ False Banana Plant.....	22
2.7.1	Enset fiber Extraction method.....	24
2.8	Coffee Plant	24
2.8.1	Coffee husk fiber extraction.....	25
2.9	Manufacturing Methods of Composites.....	26
2.9.1	Resin transfer molding:	26
2.9.2	Compression molding:	27
2.9.3	Vacuum bagging:	28
2.9.4	Hand lay-up on open mold.....	29
2.10	Factors Influencing Composite Efficiency	30
2.10.1	Treatments of natural fibers	30

2.10.2	Alkaline treatment	31
2.11	Extraction of Fiber	31
2.11.1	Mechanical Extraction method.....	31
2.11.2	Chemical extraction method.....	32
2.12	Mechanical properties of composite	32
2.13	Literature related to natural fiber reinforced composite	34
2.14	Related Literature on hybrid composite.....	35
2.15	Literature related to bumper.....	37
2.16	Literature related to fiber loading and volume ratio	37
2.17	The Knowledge Gap:	39
	Chapter Three.....	41
	Materials and Methods.....	41
3.1	Methodology of the Research	41
3.3	Fiber Collection and Extraction	43
3.3.1	Enset Fiber.....	44
3.4.1	Epoxy Resin	47
3.4.2	Hardener	47
3.5	Preparation of Epoxy and Hardener Mixture.....	48
3.5.1	Fiber Treatment	48
3.5.2	Treatment of Both Enset and Coffee Husk Fiber	49
3.6	Preparation of Mold	49
3.7	Fabrication of the Hybrid Composite	50
3.8	Preparation of Enset and Coffee Husk Fiber	56
3.9	Fabrication of Composites Specimen	56
3.10	Preparation of Specimens for Testing.....	59

3.11	Procedures and Conditions for Experiment Testing	59
	Chapter Four	65
	Results of the experiments, FEM computation, and Discussions	65
4.1	Experimental Result.....	65
4.1.1	Tensile Test Result.....	65
4.1.2	Compression Test Result.....	75
4.1.3	Flexural Test Result	81
4.1.4	Impact Test Result.....	86
4.1.5	Water Absorption Test Result	88
4.2	Discussions	90
4.2.1	Tensile Test Discussion.....	90
4.2.2	Compression Test Discussion	91
4.2.3	Flexural Strength Test Discussion.....	91
4.2.4	Impact Test Discussion	92
4.2.5	Water Absorption Test Discussion.....	93
4.3	Comparison of Results with Literatures	93
4.4	Simulation of Bajaj Qute RE60 Front Bumper.....	94
4.4.1	Finite Element Modeling and Analysis.....	95
4.4.2	Solid Works model of the Bajaj Qute RE60 front bumper.	95
4.4.3	Defining Engineering Data for the Material	96
4.4.4	Mesh Generation	97
4.4.5	Inputs for Finite Element Analysis.....	98
4.4.6	Applying Boundary Conditions and Load Conditions.....	98
4.4.7	Generating Solutions	99
4.5	Result	99

4.6 Discussion.....	100
Chapter Five.....	102
Conclusions and recommendations.....	102
4.7 Conclusions.....	102
4.8 Recommendation	104
4.9 Future Work.....	104
Reference	105

List of figures

Figure 2. 1 Classification of composite materials.....	7
Figure 2. 2 Historical Development Composite.	8
Figure 2. 3 Current Stage of Composite	9
Figure 2. 4 Future Development Composite Material	10
Figure 2. 5 Structural composites	15
Figure 2. 6 Types of fiber depending on their sources	18
Figure 2. 7 Classification of Natural Fiber	19
Figure 2. 8 Botany of coffee bean	26
Figure 2. 9 Resin transfer molding process	27
Figure 2. 10 Compression molding process	28
Figure 2. 11 Vacuum bagging process	29
Figure 2. 12 hand layup method of composite fabrication	29
Figure 2. 13 Sodium hydroxide pellets.....	31
Figure 3. 1 Methodology.....	41
Figure 3. 2 Extraction of enset fiber and treatment	44
Figure 3. 3 Finding the density of both fibers.....	45
Figure 3. 4 Mixture of epoxy and hardener	48
Figure 3. 5 Mold design and fabricated mold.....	50
Figure 3. 6 Fabrication of composite and fabricated sample.....	58
Figure 3. 7 Computerized universal testing machine.....	60
Figure 3. 8 Prepared tensile test specimen.....	60
Figure 3. 9 Tensile testing setups and sample after fracture.....	61
Figure 3. 10 Compression testing setups and samples after fracture.....	61
Figure 3. 11 Flexural testing setups and sample after fracture	62
Figure 3. 12 Charpy Impact testing machine setups.....	63
Figure 3. 13 Water absorption samples immersed in water bath.....	64
Figure 4. 1 Composite 1 (E10%, CH10%, and E80%) Tensile test Stress-Strain Curve	65
Figure 4. 2 Composite C1 Specimens Tensile Strength and their Mean	66
Figure 4. 3 Composite 2 (E5%, CH15%, and E80%) Tensile test Stress-Strain Curve ..	66
Figure 4. 4 Composite C2 Specimens Tensile Strength and their Mean	67

Figure 4. 5 Composite 3 (E15%, CH5%, and E80%) Tensile test Stress-Strain Curve ...	67
Figure 4. 6 Composite C3 Specimens Tensile Strength and their Mean	68
Figure 4. 7 Composite 4 (E15%, CH15%, and E70%) Tensile test Stress-Strain Curve	68
Figure 4. 8 Composite C4 Specimens Tensile Strength and their Mean	69
Figure 4. 9 Composite 5 (E20%, CH10%, and E70%) Tensile test Stress-Strain Curve	69
Figure 4. 10 Composite C5 Specimens Tensile Strength and their Mean	70
Figure 4. 11 Composite 6 (E10%, CH20%, and E70%) Tensile test Stress-Strain Curve	70
Figure 4. 12 Composite C6 Specimens Tensile Strength and their Mean	71
Figure 4. 13 Composite 7 (E20%, CH20%, and E60%) Tensile test Stress-Strain Curve	71
Figure 4. 14 Composite C7 Specimens Tensile Strength and their Mean	72
Figure 4. 15 Composite 8 (E30%, CH10%, and E60%) Tensile test Stress-Strain Curve	72
Figure 4. 16 Composite C8 Specimens Tensile Strength and their Mean	73
Figure 4. 17 Composite 9 (E10%, CH30%, and E60%) Tensile test Stress-Strain Curve	73
Figure 4. 18 Composite C9 Specimens Tensile Strength and their Mean	74
Figure 4. 19 OverallTensile strength of composites	74
Figure 4. 20 Tensile modulus of all composites samples.	75
Figure 4. 21 Composite C1 specimens Compression Strength and their Mean.....	76
Figure 4. 22 Composite C2 specimens Compression Strength and their Mean.....	76
Figure 4. 23 Composite C3 specimens Compression Strength and their Mean.....	77
Figure 4. 24 Composite C4 specimens Compression Strength and their Mean.....	77
Figure 4. 25 Composite C5 specimens Compression Strength and their Mean.....	78
Figure 4. 26 Composite C6 specimens Compression Strength and their Mean.....	78
Figure 4. 27 Composite C7 specimens Compression Strength and their Mean.....	79
Figure 4. 28 Composite C8 specimens Compression Strength and their Mean.....	79
Figure 4. 29 Composite C9 specimens Compression Strength and their Mean.....	80
Figure 4. 30 Compressive strength of all composites Enset/coffee husk Epoxy.	80
Figure 4. 31 Composite C1 specimens flexural strength, applied force and their mean .	81
Figure 4. 32 Composite C2 specimens flexural strength, applied force and their mean .	81

Figure 4. 33 Composite C3 specimens flexural strength, applied force and their mean .	82
Figure 4. 34 Composite C4 specimens flexural strength, applied force and their mean .	82
Figure 4. 35 Composite C5 specimens flexural strength, applied force and their mean .	83
Figure 4. 36 Composite C6 specimens flexural strength, applied force and their mean .	83
Figure 4. 37 Composite C7 specimens flexural strength, applied force and their mean .	84
Figure 4. 38 Composite C8 specimens flexural strength, applied force and their mean .	84
Figure 4.39 Composite C9 specimens flexural strength, applied force and their mean ..	85
Figure 4.40; Flexural Strength for all Enset/Coffee Husk Epoxy Composites samples...	85
Figure 4.41 Maximum testing force for all Enset/Coffee Husk Epoxy Composites.	86
Figure 4.42 Impact energy of all nine composites	88
Figure 4. 43 Bajaj Qute RE 60 overview.....	94
Figure 4. 44 Steps in ANSYS Analysis	95
Figure 4. 45 Qute RE60 bumper 3D model.	96
Figure 4. 46 Material Engineering Data of Flax/Sisal/Epoxy.....	97
Figure 4. 47 Meshing details and Meshed front bumper Model.....	97
Figure 4. 48 Input parameters and boundary conditions.....	98
Figure 4. 49 Solution Tab	99
Figure 4. 50 Result of the Equivalent Von Misses Stress.....	99
Figure 4. 51 Result of Deformation	100

List of table

Table 2. 1 property of some thermoset matrix materials.	17
Table 2. 2 Natural And Synthetic Fiber Mechanical Characters	33
Table 3. 1 Materials used in the study	43
Table 3. 2 Property of the epoxy resin used.....	47
Table 3. 3 Fiber and matrix mass composition calculation for the enset coffee husk hybrid composite	51
Table 3. 4 Composite sample one volume fraction and Mass composition.....	51
Table 3. 5 Composite sample two volume fraction and mass composition.....	52
Table 3. 6 Composite sample three properties and mass required.....	52
Table 3. 7 Composite sample four properties and mass required	53
Table 3. 8 Composite sample five properties and mass required	53
Table 3. 9 Composite sample six properties and mass required	54
Table 3. 10 Composite sample seven properties and mass required.....	54
Table 3. 11 Composite sample eight properties and mass required.....	55
Table 3. 12 Composite sample nine properties and mass required.....	55
Table 3. 13 Total mass needed for nine composites are listed as follows	56
Table 4. 1 Impact Energy result.....	86
Table 4. 2 Water absorption test result	89
Table 4. 3 The comparison of current work with others.....	94
Table 4. 4 Specification of Bajaj Qute RE60	94

Chapter One

Introduction

1 Background of the Study

Composites are typically used in buildings that need a high level of mechanical skill. Because of the improved strength-to-weight and rigidity-to-weight proportions, they have permitted the development of lighter-weight constructions that commonly replace standard metal frameworks. The combination of materials in composite constructions produces a structure with properties that none of the separate components can achieve.

In recent times, there has been a noticeable increase in the mass manufacturing of epoxy matrix-reinforced reinforced composites containing fiber and/or filler. They are widely used for a variety of structural reasons due to their remarkable strength-to-weight and stiffness-to-weight ratios, such as in the automobile, aviation, and chemical manufacturing sectors[1].

In composite products, reinforcing fibers are employed for integrating the best qualities of the two materials. These composites retain the fibers' excellent stiffness and strength while having less vulnerable to deterioration and deficiencies than homogenous materials. The matrix, which might be polyester, epoxy, or vinyl ester, keeps the reinforcements together, resulting in a variety of morphologies. The fibers carry the majority of the applied loads, increasing the matrix's both physical and mechanical characteristics.

Fiber reinforced polymer composites, in contrast to traditional materials like steel and aluminum, exhibit anisotropic properties. Unlike isotropic materials, which have identical mechanical properties in all directions, anisotropic materials have varying mechanical properties depending on the direction. Consequently, fiber reinforced polymers are considered directional materials, with the optimal mechanical properties aligned with the direction of reinforcement. To ensure the best performance, the fibers are strategically

placed within the composite material based on the anticipated load, the variety and orientation of reinforcements were chosen based on the specific use[2].

The utilization of fiber reinforced polymers has been widespread, with a primary focus on reducing weight and increasing resistance to corrosive environments. As a result, industries such as aerospace, motor sports and boating have predominantly made use of FRPs. This suggests that FRPs hold immense potential for creating structures that are not only lightweight, but also practical and cost-effective alternatives to traditional materials.

Composite materials are increasingly being used in the automobile sector due to their advantageous features, notably their low-weight structural benefits that lead to lower consumption of fuel. Furthermore, the strength of composite materials is greater than that of traditional materials such as steel and aluminum[3].

The bumper is one of the most significant car elements in terms of absorbing accident energy. In the event of a collision, a bumper is likely to be damaged since it absorbs impact energy before the rest of the vehicle's structure. As a result, the damage to the main body structure is limited and passengers are spared. The energy received from a car accident was mostly retained by the deformation caused by the plastic of the absorbing material. To guarantee that the crashed box retains all of the energy in the collisions, it must have an impact velocity that is equally dispersed to safeguard nearby structures and take all of the energy from the impact[4].

The current study is select Bajaja Quet RE60 front bumper and modeled using SOLID work and FEA using ANSYS 19.2. The thesis examines the feasibility of utilizing composite materials as alternative for materials in the production of automobile body structural components. The study focuses specifically on how composite materials react to compression and tensile loads through experimental analyses performed according to ASTM standards. The bumper is necessary for being affordable by employing low-cost composite materials as well as reaching lower weight than metallic bumpers. Additionally, this research not only conducts experiments but also presents comparative outcomes from ANSYS model simulations of composite materials based on their

intended applications. The major goal of this study is to acquire mechanical characteristics data by testing samples of composite materials. This information will be gathered and contrasted with the findings of [5], who conducted similar experiments on composite materials subjected to tensile and compression loads, as these are the most common applications of composite materials across a range of industries. Furthermore, the findings will be modeled using SOLID WORK 2016 software and analyzed by ANSYS Workbench 19.2, finite element software.

A number of investigations have attempted to use Coffee Husk in value-added applications such as particle board, fuel source, dye adsorbent, bio manure, or as an organic acid precursor. However, the majority of the Coffee Husk literature includes considerable chemical treatments and energy-intensive processes. The high manufacturing cost, poor selectivity against contaminants, and low thermal efficiency limit the use of CH in real-world applications[5].

One solution that alleviates worries about the aforementioned issues is the use of coffee husk and enset fibers. Traditionally, enset/false banana fiber was used to make fences, curtains, seat cushions, bags, string, rope, and animal feed. The fabrication of car body pieces using Enset fiber is a relatively new technique [6].

As a result, it is conceivable to design and manufacture hybrid fiber bumpers from coffee husk and enset fiber-reinforced composite materials as an alternative to imported bumpers, and it may be enhanced via composite research and application [6]. This study offered a coffee husk and enset fiber hybrid as a novel low-cost, locally plentiful material for the production of a low-speed hybrid fiber front bumper.

1.1 Problem of Statement

Currently, the number of automobile accidents on Ethiopian roads is growing. Vehicle security is also an essential study field to safeguard not only structures but also occupants in the event of an accident. In the other side the fast increase of population and development of cities required demand for transport, hence to full fill the demand recently the vehicles are imported in large amounts at the same time which requires

accessory's for replacement of their parts, so the front bumper of those vehicle is one of the parts demanded due to it is the most exposed part during crash. To minimize the above problems and to create alternative materials for the demand of composite bumpers, alternative approaches were chosen, and among them is the production and use of natural fiber-reinforced composite bumpers.

Utilization of Enset – Coffee husk hybrid reinforced epoxy for bumper production is thus one alternative, and it seems capable to use these raw materials for such purpose. The reason for using coffee husk and enset fibers rather than individual fibers is to improve the impact strength and flexural and tensile moduli. It also increases the possibility of utilizing both raw materials for bumper production will be investigated concurrently.

1.2 Objective

1.2.1 General objective

The general goal of this thesis is to create and describe Enset-coffee husk fiber-reinforced epoxy hybrids composites of varied proportions.

1.2.2 Specific objectives

- Fabrication of Enset-coffee husk–epoxy hybrid composite with different composition using hand lay-up manufacturing technique.
- To investigate and analyze the mechanical properties of Enset-coffee husk - Epoxy hybrid composites with different compositions in terms of tensile, compression, flexural, impact, and physical properties such as water absorption using ASTM standards.
- To simulate and explore the recommended material for Qute RE60 Front bumper model using ANSYS 19.2 software
- Evaluating and comparing the appropriateness of the created composite material for the desired application.

1.3 Research Questions

- Which of the evaluated enset-coffee husk hybrid fiber reinforced epoxy composite formulations possesses the best mechanical and physical properties?
- Is it possible to use natural fiber hybrid composite for automotive bumper applications?
- Is it possible to fabricate and characterize the Enset-Coffee husk hybrid with Epoxy matrix for low-speed crash front bumper?

1.4 Scope of the study

Bajaj Qute RE60 vehicles may be spotted all across the country and have served an important role in delivering people and freight mobility. This thesis is only applicable to Bajaj Qute RE60 automobiles. As a result, the goal of this thesis is to reduce imported bumpers by applying the best bumper design model.

In this investigation, Enset-coffee husk epoxy hybrid composite specimens of varied compositions will be manufactured to achieve good mechanical and physical qualities. It comprises hand-layup manufacture and experimental tensile, compression, flexural, and water absorption characterization using ASTM standards. Finite element modeling of the bumper and product analysis using ANSYS 19.2 software [7].

1.5 Limitations of the Study

There were various challenges in finishing this thesis paper. The initial and most common experimental setups are quite restricted, and finding facilities and machinery to test all experiments under one roof proved impossible. Furthermore, it was difficult to locate apparatus and methods for measuring single fiber density, diameter, and other parameters. Furthermore, little study has been conducted on the hybrid natural composite of Enset and coffee husk fiber.

1.6 Organization of the Study

The following sections will be included in the thesis:

Chapter One: intends to explain the overall context of the topic as well as the reason for conducting the research.

Chapter Two: reviews various literatures to address the detailed science behind natural hybrid composites.

Chapter Three: Describes the materials utilized, the techniques of preparation, the procedure, and the circumstances for preparing the samples required for testing.

Chapter Four: The different experimental test findings and ANSYS software results are contrasted and explained in depth.

Chapter Five: According to the data, develops a conclusion and suggestions In addition, future work is suggested.

Chapter Two

Literature Review

2 Composite Materials

Composite are materials composed of at least two distinct fundamental components. The chemical and physical characteristics of these materials vary widely [8].

The matrix phase shields the reinforcing element from environmental degradation, transmits loads across the two, and maintains the reinforcement in place. The reinforcement phase is the principal load-carrying part of the composite material[9].

Versatility, high strength-to-weight ratio, corrosion-resistant, good rigidity, excellent dumping, low electrical conductivity, light in weight, and inexpensive cost are only some of the advantages of composite materials in contrast with traditional materials. However, composite materials have constraints such as long development time, low elasticity, temperature restriction, and moisture absorption approach. [10][11].

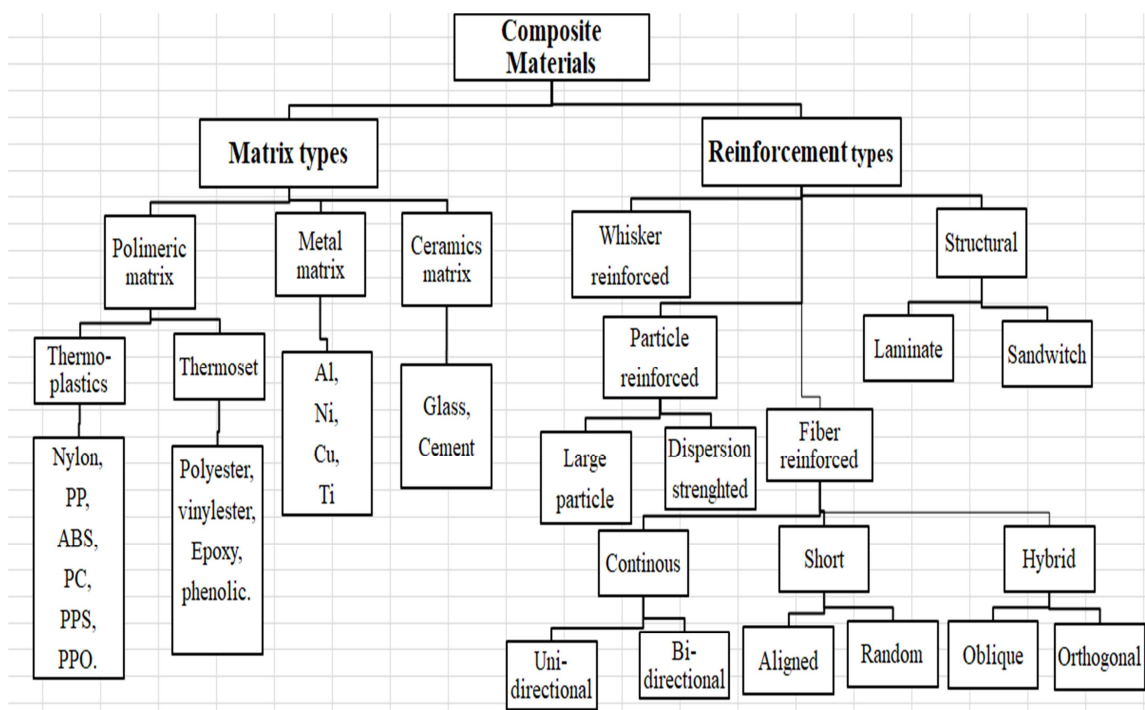

Figure 2. 1 Classification of composite materials

2.1 Development of Composites

Years after the discovery and administration of fire, the emergence of the wheel and the spinning of continuous strands contributed to the success of the composite to make mankind's life easier. Enabling it to stay alive outside the tropical other climate zones and extends over the surface of the Earth. From 3400 B.C. Chipboard that was made in Persia by binding pieces of wood together in different stages, became popular. In Mesopotamia and Egypt, beginning around 1,500 BC, they employed natural composite building supplies such as straws and wood to reinforce the bricks made of mud utilized for the making of homes, ships, and pottery application. In Egypt, between 2181 and 2055 BC, used sheets of linens or papers were put into plaster[12].

Materials science analyzes influencing factors such as material properties that are influenced by composition, manufacturing method, and structure. Two or more Nano, microelements, or constituents that do not dissipate into one another comprise composite components.

One of the earliest composite materials, Structural composite significant material, was already utilized more than any other reinforced concrete[12]. More strong materials as wood and metal soon changed due to very it old composites.



Figure 2. 2 Historical Development Composite that shows ancient people made several traditional equipment's from wood, sand, and soil using a different method [12].

Present:

Having begun in early agricultural villages and lasted almost a century, a genuine renaissance occurred in the second part of the twentieth century with the use of lightweight composite structures for a range of technical solutions. Initially used exclusively for their electromagnetic characteristics (insulators and radar shields). In the last two decades, composites were widely used to improve the structural integrity of spaceships and airplanes for the military. Continuous fiber-reinforced composites are now well-established essential materials in the automotive and aerospace industries for component manufacturing[13]. In this case, composite fabrics allow design freedom at any cost. With the development of improved resources and growing expenses, cost reduction in production and process is the key technology controller current time [12].

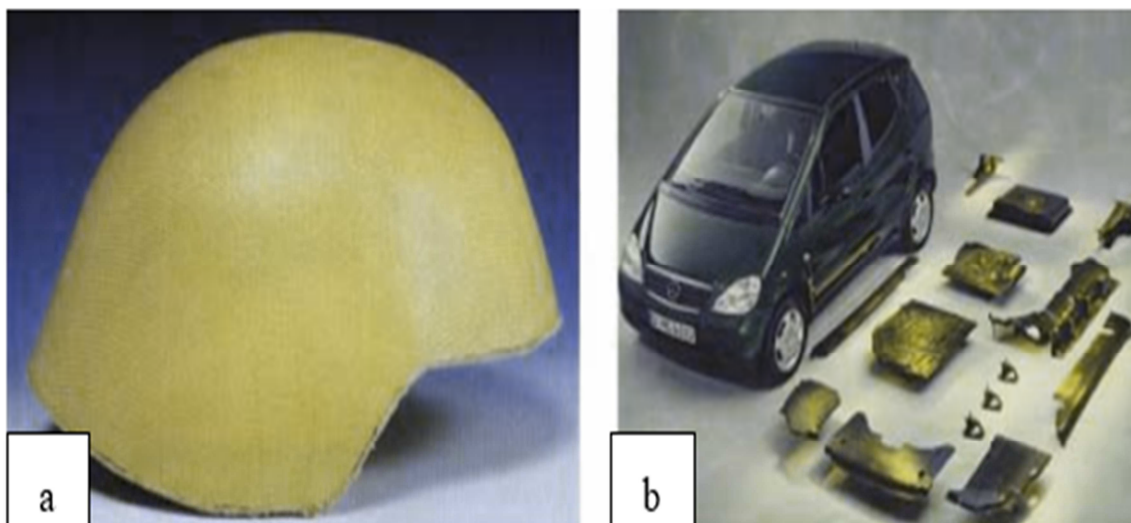

Figure 2. 3 Current Stage of Composite, a) military purpose,(b)automobile purpose [14].

Future:

In the future, composites will almost certainly be created using a more complex design approach, resulting in the best possible structure and mechanical design based on stated requirements like durability, stiffness, shape, mass, strength and costs, etc. [15]. Newly created design material must be able to show clients the impact of a design modification like building as shown Figure 2.4. By improving productivity and operations, this improvement in material features has enabled us to continue moving economically

around the world [16]. The commercial aviation industry is under constant flows to enhance performance because to rising fuel costs and environmental activism, and weight reduction is a crucial element. Beyond the day-to-day operational costs, component count reduction and corrosion reduction can simplify material maintenance the in future.

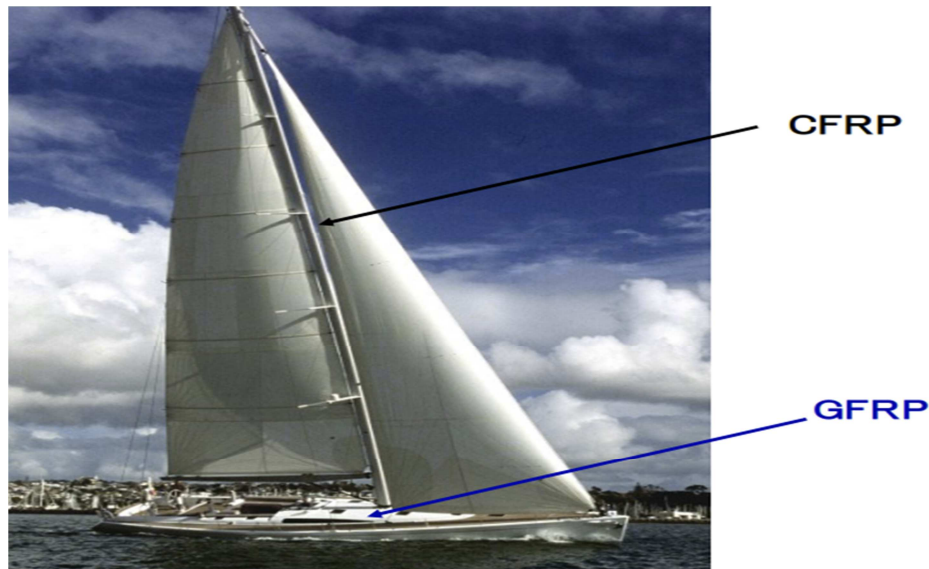

Figure 2. 4 Future Development Composite Material[15].

2.2 Classification of composite

2.2.1 Classification based on matrix material

According to the nature of the constituents (reinforcement and matrices), composite materials are categorized into many classes. Composite materials are classified into four types based on their matrix composition [6]. They are as follows:

- a) Metal Matrix Composites (MMC)
- b) Ceramic Matrix Composites (CMC)
- c) Polymer Matrix Composites (PMC)
- d) Carbon and Graphitic Matrix Composites (CGMC)

2.2.2 Metal Matrix Composite

Metal matrix composites are made up of a metallic matrix and a distributed layer of fibers [7]. MMC provides various advantages over monolithic metals, such as greater tensile modulus, better specific strength, enhanced mechanical characteristics at high temperatures, and a lower coefficient of thermal expansion [1].

Metal matrix composites are being examined for a variety of applications due to their qualities, including combustion chamber nozzles (in rockets and space shuttles), housings, tubes, cables, heat exchangers, structural components, and so on. At high temperatures, they have the potential to be structural materials. The most widely utilized metals are titanium, aluminum, magnesium, and copper, as well as super alloys. Nickel and cobalt are the most often utilized metallic matrices[2].

2.2.3 Ceramic Matrix Composite

Ceramic matrix composites (CMCs) are typically employed in high-temperature applications where environmental assault is a concern. Ceramic possesses key properties such as high stiffness, hardness, compressive strength, and low density. It is, nevertheless, fragile and has low fracture toughness. CMC is intended to preserve the main features of ceramics while compensating for weaknesses such as brittleness and poor fracture toughness in the material. The primary objective for developing ceramic matrix composite is to improve the toughness of the material.[1][17].

A wide range of nonmetallic inorganic substances are referred to as ceramic matrix composites. The primary goal of employing CMCs is to enhance toughness. A ceramic matrix and dispersed fibers are used to create these composites [18]. They are the logical choice for high-temperature applications over 15000 degrees Celsius. Because of these factors, it is also difficult to produce them inexpensively. Silicon carbide, zinc, calcium phosphate, Oxides, Nitrides, Borides, and Silicide's, for example, all have melting temperatures more than 1600°C (2912°F)[19][20].

2.2.4 Polymer Matrix Composite

Polymer matrix composite is a very utilized category of matrices. A polymer is a long-chain molecule composed of one or more repeating units of atoms connected by strong

covalent bonds. Polymer molecules in a solid form can be seen as being frozen in space [21].

They can be orientated in a random way (as in amorphous polymers) or in a combination of randomized and ordered form (as in semi-crystalline polymers). Polymer matrix composites offer excellent features such as high stiffness and fracture toughness, as well as resistance to corrosion and abrasion [22]. Polymers offer a low-density, chemically resistant matrix that is ideal for uses in aviation, particularly in the construction of fuselages and wings.

Merits of polymer matrix [20]

- Low density
- Low thermal conductivities
- Translucence
- Low electrical conductivities
- Good corrosion resistance
- Aesthetic color effects

Limitation

- Low transverse strength
- Poor stiffness
- Low operational temperature limit
- The poor mechanical properties of polymers are overcome by reinforcements with suitable particles, whiskers or fibers[1][23].

2.3 Reinforcement Material

Reinforcement materials are the leading component of composites, providing strength, toughness, and structural load support. As a result, selecting the right reinforcement is critical for obtaining the desired completed product with the desired qualities. Fiber Reinforced Composite, Particle Reinforced Composite, Whisker Reinforced Composite, and Structural Reinforced Composite are examples of reinforcing materials [14].

2.3.1 Fiber Reinforced Composite

Fiber-reinforced composites are created by embedding fibers in a matrix material. Fibers are classified into two types: continuous/long fibers and short/chopped fibers. Fiber direction, fiber being loaded, and fiber dispersion all possess an influence on fibers, which are an essential class of reinforcements because they accomplish the appropriate conditions and transmit strength to the matrix elements, influencing and increasing their characteristics as needed.

Fiber-reinforced composite materials are made up mostly of reinforcing fibers and certain matrix elements. A fiber has an excellent modulus and strength, while a matrix serves as a binder for the fiber. Fibers are discontinuous small-to-short reinforcing materials made from diverse materials such as steel, plastic, glass, carbon, and natural materials in a variety of forms and sizes[20].

Fibers are roughly categorized into two major types. Natural fiber composites and synthetic fiber composites are two types of composites. Natural fiber composites are composites in which the fiber originates naturally (for example, sisal, bamboo, and so on). Artificial composites are artificially created by mixing two or more elements in certain quantities under regulated conditions (for example, carbon, glass, etc.). The fibers rely on fiber qualities such as length, strength, flexibility, maturity, proximity to water, alkali, acids, and so on. As per the study, synthetic fibers can be supplied with the desired qualities. Synthetic fibers are tougher than organic ones, easier to process, and have a longer lifespan[24].

2.3.2 Particle Reinforced Composite

Particle-reinforced materials are composed of fragments that are dispersed as support in a matrix. There are no lengthy dimensions for these particles. They have polyhedral, ellipsoidal, sphere-like, or odd shapes [25].

Particulate-reinforced composites are strengthened by the hydraulic repression of fillers in the matrix and are tough in comparison to the matrix. Because of the three systematical perpendicular planes, three-dimensional reinforcement particles in composites give

isotropic material characteristics. At the same time, it is not similar; the material behaviors gain compassion for the array's geometric forms and bonding qualities. The composite strength was generally determined by particle size, particle setup, and reinforcing volume fraction[26].

2.3.3 Whisker Reinforced Composite

Whiskers are a type of fiber that has a single crystal microstructure. Whiskers are shorter in length than regular fibers. Their composite arrangement is strong, and the most effective application is made with this reinforcement material [20].

Whisker-reinforced CMC has lately attracted a lot of interest for use as elevated temperatures structural components in sophisticated heat engines and high-temperature energy conversion systems, for example. The gains in strength during fractures and resilience to fractures that can be obtained are of tremendous importance for applications demanding mechanical reliability [27].

The influence of the whisker/matrix interaction features on the strengthening and toughening mechanisms is very important for enhancing the mechanical dependability of these composites. Whisker reinforcements are primarily used to prevent catastrophic brittle failure by providing energy dissipation mechanisms during fracture propagation. The degree of energy dissipation is determined by the nature of the whisker/matrix interface, which may be influenced significantly by matrix chemistry, whisker surface chemistry, and processing factors[28].

2.3.4 Structural Reinforced Composite

They are classified into two types: sandwich and laminar. The sandwich is made of layered composite material having an exterior and an interior. It is composed of two robust exterior sheets, while the interior is composed of a thick material stack. Honeycomb or foam can be used as the base material. The core's size may be modified as needed. [20].

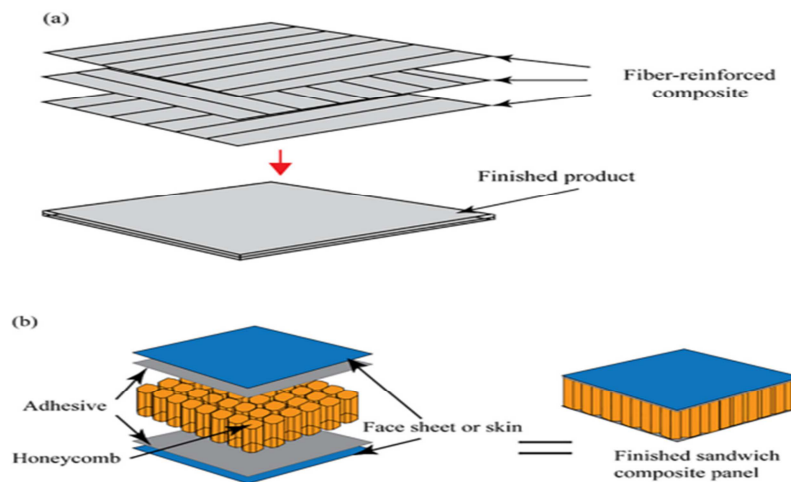

Figure 2. 5 Structural composites (a) laminar composite (b) sandwich panel[20].

2.4 Matrix Material

Matrix materials are used for binds the reinforcement fibers together, Transfers loads and stresses within the composite structure. The matrix shields the reinforcement from structural and chemical deterioration. It adds to the overall framework. It provides the composite structure and develop, toughness, stability over buckling, and stress distribution[7][21].

2.4.1 Thermosetting Resins

Epoxy, Unsaturated Polyester, and Vinyl Ester are the most often used resins. Chemical cross-linking is a technique that converts liquid resin into a hard solid. These results in the development of a densely bonded three-dimensional network, which gives the polymer block its strength. The mechanical characteristics of diverse resins are determined by the molecular units that comprise the networks. They are also affected by the length and density of cross-links. The thermosetting resins' most noticeable attribute is that they have reduced stresses to failure. These are mostly considered fragile materials[20,29].

2.4.2 Thermoplastics Resins

These polymers have no cross-linking structure. The qualities of the individual monomer units, and also the extremely high molecular weight, contribute to their stiffness and strength. The benefit of thermoplastics is that there is a high concentration of molecular entanglements in amorphous thermoplastics. These serve as cross-links [30].

Semi-crystalline materials exhibit some degree of molecular order and alignment. The disentanglement of molecules in thermoplastics causes them to transition from a solid to a somewhat liquid (viscous) state when heated. A spherical The crystalline components are heated to generate a viscous liquid. Anisotropic features characterize these materials. They are chemically resistant and thermally stable. Many thermoplastics are also impermeable to water. The most common trait is that all thermoplastics flex significantly before ultimate breakage. Nylon, polypropylene, acrylics, and other thermoplastics are commonly utilized [20,21][31].

2.4.3 Epoxy

Epoxies are a widely recognized and useful thermosetting polymer that is used in combination with a hardener, which is a drying cross-link chemical. [32]. Despite its high practical strength, waterproofing, chemical susceptibility, superior thermal insulation, outstanding adhesion characteristics, and stiffness, epoxy has poor UV resistance [8]. The resin's microstructure may be pressed to create a range of items with varied levels of efficiency. Epoxies are generally utilized to make exceptionally well-performance composites with outstanding mechanical qualities. They outperform polyester resins and phenolic resins. Epoxy resin has several advantages, including good mechanical and thermal qualities, high water resistance, a long working duration, and minimal cure shrinkage. It also has certain disadvantages, including high cost, crucial mixing, caustic handling, and limited UV resistance. [22].

The thermoset polymer matrix is employed as a binding material in this work. This is known as Epoxy resin. Epoxy resins are low molecular weight pre-polymers that may be treated in a variety of ways. The epoxy matrix's purpose is to hold the fiber in place and transfer loads to the fibers. [1].

Epoxy resins have the benefit of being able to be partially cured and kept in that state, as well as having minimal polymerization shrinkages during cures, exceptional mechanical strength, outstanding resistance to chemicals and solvents, and excellent adherence to fibers. In this investigation, AY-105 epoxy with 2021 hardener was employed, which is chemically related to the epoxide family. The two ring groups in the heart of the epoxy molecule help it absorb mechanical and thermal stresses better than linear groups. It contributes to the epoxy resin's excellent rigidity, hardness, and heat resistance [1] [25]. Because of its high adhesive properties, epoxy resin requires a long curing time and has poor mold release qualities.

Table 2. 1 property of some thermoset matrix materials[20].

Resin Materials	Density (g/cm³)	Tensile Modulus GPa (10⁶ psi)	Tensile Strength MPa (10³ psi)
Epoxy	1.2 – 1.4	2.5 -5.0 (0.36 -0.72)	50 – 110 (7.2 - 16)
Phenolic	1.2 – 1.4	2.7 -4.1 (0.4 -0.6)	35 – 60 (5 - 9)
Polyester	1.2 – 1.4	1.6 -4.1 (0.23 -0.6)	35 – 95 (5.0 – 13.8)

The following characteristics should be found in a good resin:[22].

Good impregnation - enables fibers to connect with Matrix to form strong bonds.

Moisture content is controlled - therefore environmental influences shouldn't have an impact on its usage.

Non-toxic- is it safe to work with common safety requirements.

High availability – is availability in market is the most useful thing.

2.5 Fibers

By virtue of their anisotropy, fibers represent a distinct class of materials. Fibers are long in comparison to their diameter. This known as the high aspect ratio accounts for the material's distinct features in comparison to the entire material. Common fibers for use in

composites have strong strength and stiffness parallel to the fiber axis but are weak and flexible perpendicular to it.[20].

2.5.1 Types of Fibers

Relying on the origin of the fiber, there are two sorts of fibers. The two varieties are natural fiber and synthetic fibers.

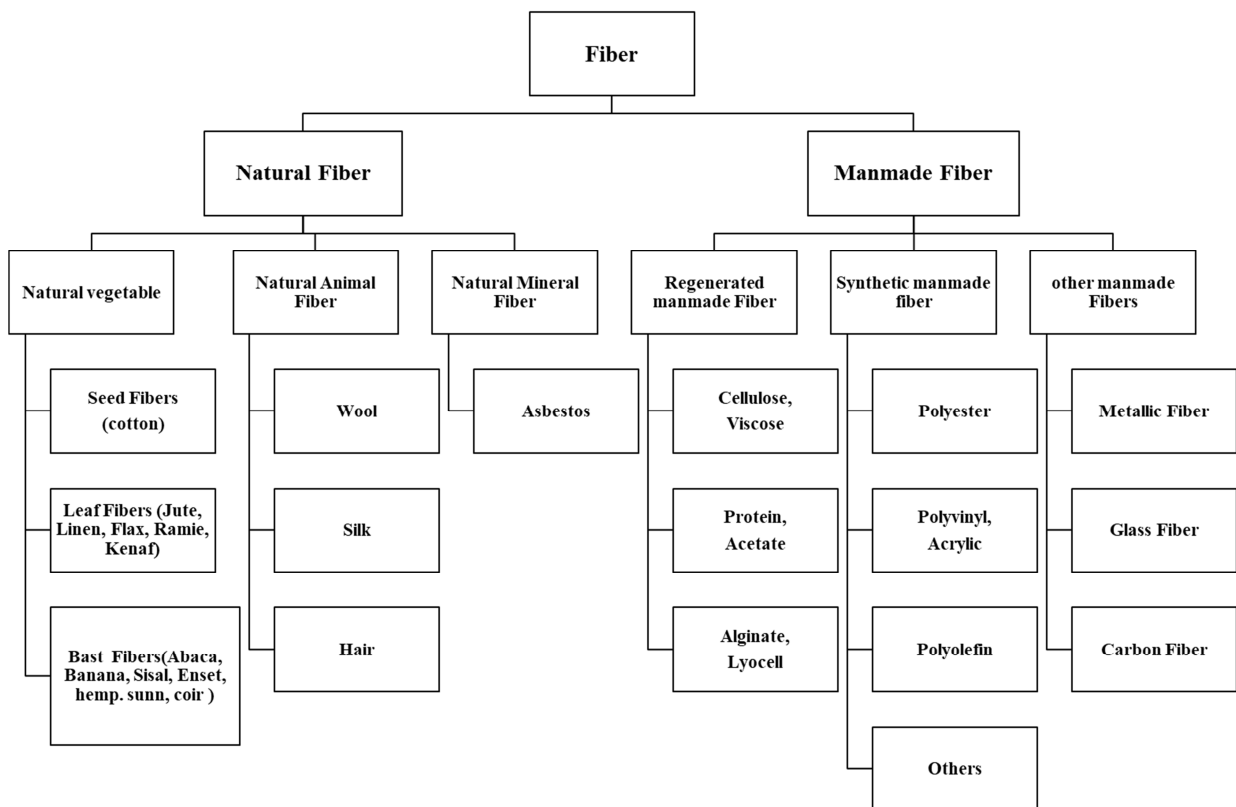

Figure 2. 6 Types of fiber depending on their sources [15].

2.5.2 Natural Fibers

Natural fiber grows naturally plant; there is non-homogeneity in their property. Cellulose is the most essential structural factor of which fibers are commonly used. Researchers are increasingly interested in natural fiber-reinforced composites because fiber plant is lightweight, has low prices and is readily available, and are recyclable in a range of industries; Composites made of natural fibers may be able to replace artificial fibers [18]. Natural fiber-reinforced polymer composite materials are becoming increasingly popular

in both industry and fundamental research. They are completely or mostly recyclable, renewable, nontoxic, and inexpensive. Composites made from natural fibers are used in a range of sectors, including aerospace, railroads, trucks, and coaches, military applications, other themes mentioned include building and development (ceiling panels, partition boards), packaging, consumer goods, and others[33]. Bast, leaf, seed, fruit, grasses/reeds, and wood fibers are all-natural fibers found on plantations. Four main purposes natural fibers are becoming increasingly popular. Specific features, pricing, benefits, and recyclability are only a few examples [16].

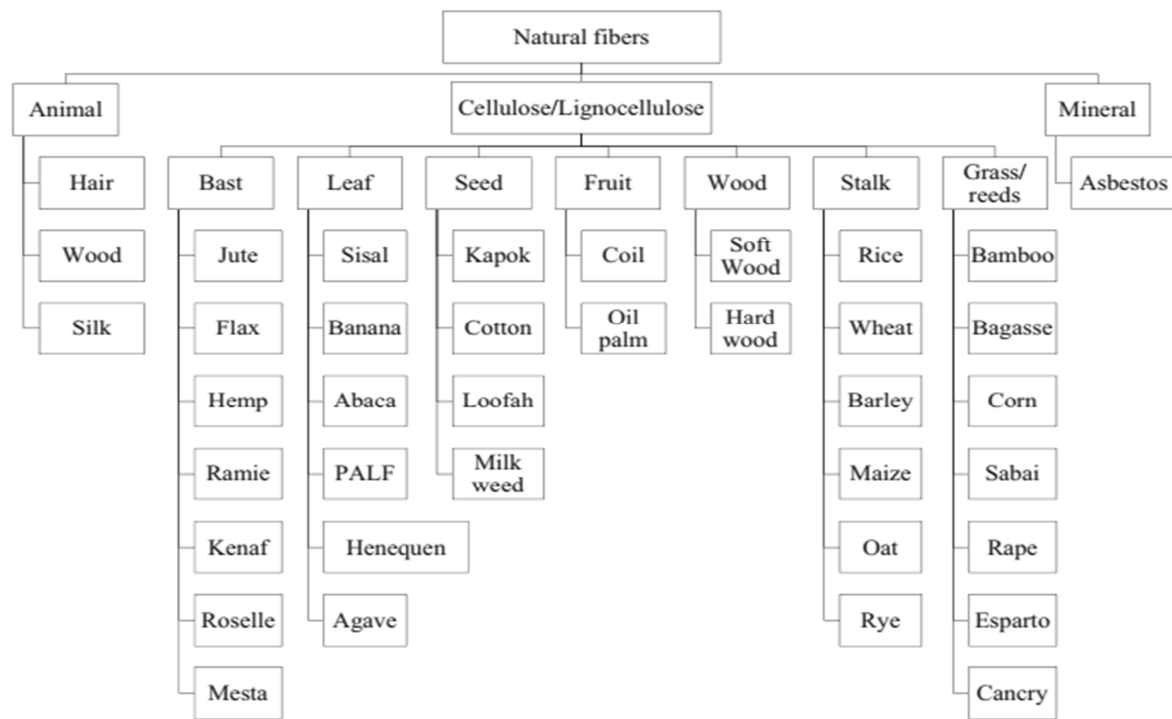

Figure 2. 7 Classification of Natural Fiber [33].

The Advantages of natural fibers are;[20].

- Natural fibers are environmentally friendly;
- They possess a low specific weight, which gives them more strength;
- They have superior electrical resistivity.
- They are non-irritating to the skin,

- Their manufacture uses less energy and generates less emissions of carbon dioxide.
- An expensive in cost.
- They have excellent thermal and insulating qualities.

Limitation of natural fibers

Natural fibers are often hydrophilic, meaning they can hold moisture. The plant fiber cell wall has a substantial quantity of hydrogen bonding (hydroxyl groups OH). When wetness accumulates in the fiber, these hydroxyl groups form new hydrogen bonds with water molecules. This is owing to insufficient fiber-matrix bonding, matrix fracture, geometrical instabilities, and poor mechanical characteristics of the composites[34]. As a result, moisture must be extracted from the fibers prior to the manufacture of the composites. Aside from that, natural fiber retention of water can be lowered by chemical treatments such as alkali, salt, acetylation, and peroxide [35]. Livestock fibers, mineral fibers, and plant-based fibers are the three categories of natural fibers depending on their origin. NF composites are outstanding performance composite materials made up of polymer matrices and natural fiber reinforcement[36].

Animal Fibers: Wool and silk are examples of animal-derived fibers. Animal Fibers are made up entirely of proteins and the animal's protecting epidermal coating. Animal Fibers are derived from sheep, camels, cashmere and mohair goats, rabbits, yak, silkworms, and Vicuna[37].

Mineral Fibers: Mineral-based fibers are inorganic minerals that have been formed into fibers, such as asbestos. These fibers are flame and chemical resistance and are utilized in industrial applications[16].

Plant Fibers: Plant's natural fibers are organic fibers made up of cellulose, hemicellulose, lignin, pectin, and wax. They are broadly accessible, which is the fundamental cause why this sort of fiber is preferred among others.[38]. Origin, aging environment, techniques for processing, growth circumstances, and topographical and climatic variables may all affect plant fiber characteristics and qualities. At this level of

advancement, biodiversity, location, and climate influence the quality and characteristics of the environment. At the time of collection, age and cell wall thickness might have an impact on quality. Even the extraction method may have a considerable influence on the fiber's quality and characteristics. As a result, prior to processing and selection, it is critical to conduct a thorough investigation of the fibers[33].

These fibers have many advantages, including renewability, recyclable, biodegradability, environmental friendliness, and low cost. Some disadvantages include being hydrophilic, having poor wettability, having weak fiber-matrix interfacial bonding, becoming readily broken during manufacture, and deteriorating at temperatures exceeding 2000 °C. Because of these factors, the rigidity of plant fiber-reinforced composites is reduced [22].

Natural plant fibers are categorized into six groups depending on the plant portion removed. A few of them are the bast fibers, leaf plant fibers, seed plant fibers, fruit plant fibers, wooden plant fibers, stalks plant fibers, and grasses plant fibers[36].

Bast fiber: They come from the outer layer or bast. They are stronger than other plant fibers in terms of tensile strength. Bast fibers are those taken from the outer cell layers of many plants' stems. Enset (false banana), flax, jute, hemp, ramie, and kenaf belong to the principal plants used to furnish bast fibers. Because they are yearly crops, there is an abundance of materials, and they have gained popularity in a number of non-wood composite production techniques[29].

2.6 The Need for Hybrid Composites

A hybrid composite is one that has at least two different reinforcing fibers in the matrix. The elevated material and manufacturing costs, toxicity, and specific gravity of artificial fibers stimulated a passion for natural fibers [39]. Organic fibers had their applicability limited due to their lower mechanical characteristics when contrasted with synthetic fibers. Natural fibers' substantial moisture intake, poor wettability, limited thermal stability, and poor bonding capabilities are just among some of its drawbacks[40].

Conventional FRP composites are not as advanced as hybrid composites. Numerous reinforcing phases with just one matrix phase, a sole reinforcing phase with numerous

matrix phases, or various reinforcing phases and several matrix phases are all possible in hybrids. They are less rigid than other fiber - reinforced composites. It is typically made up of an elevated modulus fiber and a lower modulus fiber. The high-modulus fiber provides strength and load-carrying capabilities, while the lower-modulus fiber causes the composite more damage resistant and retains the material expense reasonable. The mechanical characteristics of the hybrid material can be varied by modifying the volume ratio and layering arrangement of various plies[41].

Composite developers can modify the qualities of the composite material through hybridization to match their individual demands. Because the purpose of composites is to combine the greatest characteristics of all parts, hybrid composites offer an excellent chance to obtain the optimum cost-performance ratio. Hybrid fibers with variable orientations are becoming more frequent. Because the component fibers are well blended, there are no distinct groups of either kind of fiber in the composite [34].

Composites with a mix of more than one particle reinforcement to improve have the ability of improving the mechanical characteristics of composite materials. The performance of hybrid composites is the consequence of individual elements cooperating to produce a better balance of benefits and drawbacks[42]. Hybrid composites have numerous applications in the technology, medicinal, military sectors, and many others.

Composites studies have been one of the most interesting pursuits in technological and scientific research over the past 30 years. Many approaches are used to alter the composition and regulate the characteristics of this miraculous substance. For specialized uses, new composite materials are invented, and the knowledge is transmitted to companies for large-scale manufacturing. The coupling of structural inorganic materials with active natural and biological parts, in particular, resulted in hybrid materials playing the most diverse role in several fields of materials science and technology[43].

2.7 Enset/ False Banana Plant

The enset plant, similar to the banana, belongs to the Musa family. The plant is a big continuous herb having pseudo stems formed from leaf sheaths. Its overall height ranges

from 3.0 to 12.2 meters, and it is encircled by 8 to 12 big leaflets. The leaves may grow to be as much as 9 feet tall and 2 feet broad (2.7 meters and 0.61 meters, respectively). Its fruits range in size from 4 to 12 inches (10.2- 30.5 cm) [44]. Enset tree components are used for a variety of purposes, including fruits as "KOCHO" sources of food, leaf for packaging, and stems for fiber and clothing. The fiber is extracted by crushing the plant's stalks' outermost layers. It is lightweight, robust, and long-lasting. It produces a white glossy hue fiber after extracting and drying. One distinguishing feature of the fiber above all other fibers in this category they have high toughness and resistance to moisture behavior, making it particularly suitable for marine ropes[33].

The southwest highlands of Ethiopia are the most rapidly growing locations. This isn't to say that enset isn't grown and consumed as a food source in these locations. It is a popular component in the southwest, central, and towns known for its exquisite Ethiopian meal, kitfo. Figure 2.1 depicts the enset growth zones in the southwest highlands. Ethiopia the key elements of vegetation and food plan vary around the nation based on the climate and Agro-ecology. More than one-sixth of Ethiopia's population (almost 15 million people) is dependent on enset[29].



Figure 2.8 Enset plant [29]

2.7.1 Enset fiber Extraction method

There are two techniques for creating Enset fiber: stripping and decortications is conducted by a decorticator.

Stripping techniques: The most typical and earliest technique for taking out fiber from leaf sheaths involves two basic activities: first, splitting the fibrous outermost part from every leaf sheath (this exterior layer is commonly referred to as "tuxy" and this process is known as "tuxying"); and secondly, eliminating pulpy stuff, thus clearing the strands of fiber of the tuxy (this operation is called stripping or cleaning). Both activities should be completed as quickly as the stalk is toppled.

Tuxying is usually done outdoors. The worker slips a knife tip through the leaf sheath's exterior and interior layers, releasing a 1 to 3-inch broad end of the outer layer. This strip, also known as the tuxy, is cut throughout the entire length of the sheath. Every leaf sheath produces around 2-3 tuxies. After removing all tuxies from the leaf sheath, they are taken off the stalk and placed on the farm for natural fertilizer. Usually, another person will gather these tuxes and deliver them to the stripping or washing facility[29][45].

Decortications: Cleaning fake banana fiber is done with a decorticator. Machines that extract fibers from plant stems are known as little spreaders [29]. Following the end of processing and fermentation area setup, the pseudo stem and corm had been separated and the corm was splatted into 4-8 pieces depending on their sizes, and the outside surface of the leaf sheath (shafa) was removed and scrapped using conventional tools (Sisa). The upper part of the leaf sheath was then scraped downwards. Fibers were retrieved as a byproduct by rubbing the fragile leaf sheath frequently. Scraping while sitting is fairly prevalent in the nation; it is shredded with a knife[46].

2.8 Coffee Plant

Coffee is a species of flowering plant in the Rubiaceae family. Coffee species, which are bushes or tiny trees, are found in tropical and southern Africa, and also tropical Asia. Coffee beans, the seeds from various species, serve to flavor a wide range of drinks and

foods. Like the seeds, the fruits are strong in caffeine, have a distinctly sweet flavor, and are usually juiced. [47].

It is an important export crop for many countries, notably those in Latin and South America, the Caribbean, and Africa, and it has become one of the greatest valuable and commonly traded goods in the world. Ethiopia is the the planet's fifth largest coffee provider and is said to be the birthplace of Arabica coffee. Central Africa is said to be the origin of strong coffee[48][6]. The coffee husk was obtained in the Gedeo district of Yerga Caffé town.



a) Coffee plant

b) dry coffee fruits

c) dry processed coffee husk

Figure 2. 9 coffee plant and dry processed Coffee husk[5].

2.8.1 Coffee husk fiber extraction

Coffee beans can be prepared using either wet or dry processes. Fruits are either exposed to the sun or electrically dried (in furnaces) in a dry state. To retrieve the seeds (beans), the exocarp (outer peel), mesocarp (pulp), and endocarp (parchment) of dried cherry coffee must be removed. During the wet processing process, fruits are pulped, fermented, washed, and dried in the sun or in a furnace [5].

In the pulping procedure, the exocarp and most of the mesocarp are eliminated, leaving behind the "coffee pulp." The dried coffee is known as dry parchment coffee because the endocarp (parchment) is not removed during the wet processing phase. Hulls

are formed when dry parchment coffee is hulled. The exocarp, mesocarp, and endocarp account for 60% of the dried fruit mass[47].

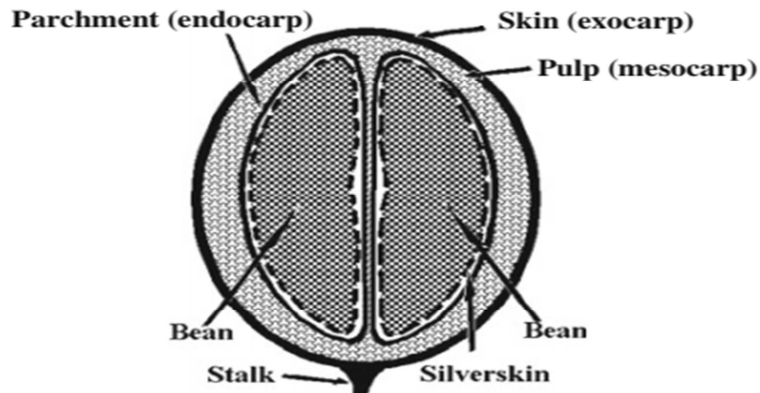

Figure 2. 8 Botany of coffee bean [47].

2.9 Manufacturing Methods of Composites

Whether it is simple or complex, single or multiple, there are various methods for casting a composite structure. Each technique has its own benefits and limitations. Specific manufacturing process selection is dependent on the type of matrix and fibers, the pressure requirement for the high viscous resin to flow through the fibers, the temperature for the matrix to be produced and cured, the end product geometry, and cost savings. [20]. Some of the commonly used manufacturing techniques are;

2.9.1 Resin transfer molding:

Resin transfer molding is best for pre-regs and autoclave-based composite manufacture and rigid closed mold is included. To start the process, the reinforcing mat is draped across the bottom half of the mould. The top mold is then filled, and a catalyzed, low-viscosity (heated) resin is poured into the mold under pressure, removing any air and venting it through the corners until the mold is completely filled the resin is allowed to cure while the mold is clamped. The major benefit of RTM is that the composite dimensions are solely determined by the mold shape, that the composites produced have a good surface quality on both sides, and that they are prepared to use without additional

treatment. Most aerospace components, including door pillars, stringers, reinforced panels, rudder tips, and ribs, are manufactured using RTM since it is less expensive than other methods [13][49].

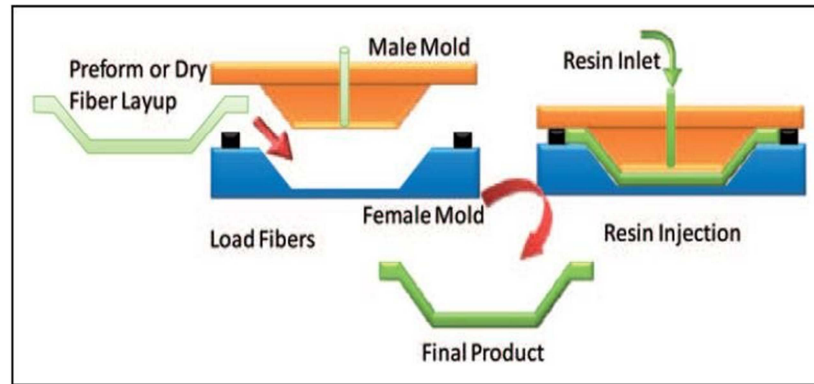

Figure 2. 9 Resin transfer molding process[49] .

2.9.2 Compression molding:

Compression molding is one of a number of molding techniques. Raw materials such as hydraulic and pneumatic components are shaped using a metal mold and compression (force) and heat. The initial material will warm in the mold for a set amount of time while the mold is closed. Extra materials, commonly known as flashing, that have ejected while being warmed and compressed in the mold are common when the molded object is removed[50].

To ensure the exact measurement of the product manufactured, an experienced cleaning staff removes flashing. Compression molding, on the other hand, is not suited for all parts since it typically results in poor product consistency and difficulty controlling flashing. Knit lines are reduced and fiber length breakdown is decreased as compared to injection molding. Compression molding is also perfect for making ultra-large basic shapes that are larger than the machine's limit. To ensure the exact measurement of the product manufactured, an experienced cleaning staff removes flashing.

Compression molding, on the other way, frequently results in poor product similarity and trouble controlling flashing, and it is not ideal for all parts. When compared to injection

molding, there are fewer knit lines and less fiber length depreciation. Compression molding can also be used to create extremely big basic shapes that are too large for extrusion. Polyester fiberglass resin systems are examples of materials that are commonly produced using compression molding[6][29].

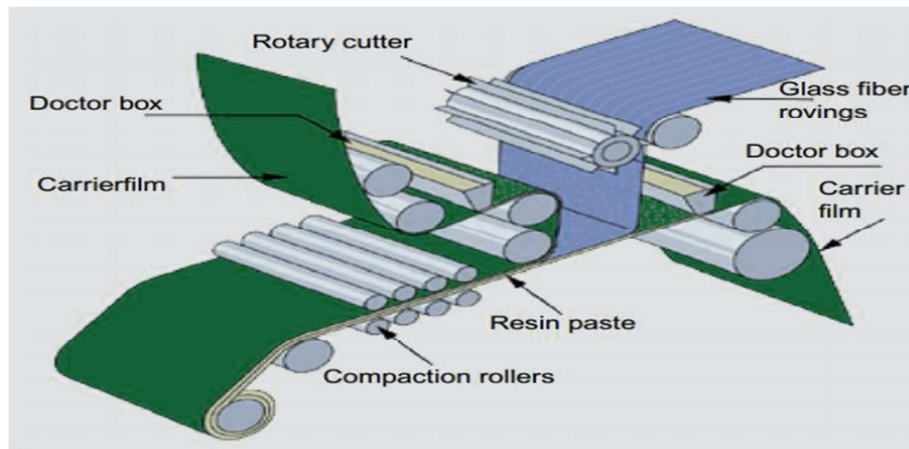

Figure 2. 10 Compression molding process [14].

2.9.3 Vacuum bagging:

Heating a piece of plastic to a forming temperature, vacuuming it, stretching it over a single-surface mold, and pressing it into the mold are all examples of vacuum forming. This technology may be employed to create persistent plastic composites such as roadway signs and protecting coverings. Draft angles are typically provided in mold design (a minimum of 3° is suggested) to make rejecting the manufactured plastic item from the mold simpler. Thermoplastics are the most preferred materials for vacuum shaping. In nearly any shape, this might be molded onto wood, structural foam, cast, or fabricated aluminum casting.

Vacuum forming is also possible with transparent materials like acrylic, which are often used in aircraft applications. The most unusual vacuum forming application is to reproduce any small object multiple times, then vacuum form the new pattern to create a more integrated form. The vacuum forming binds the separate pieces together, resulting in a single mold that can be created automatically. The plastic form can subsequently be filled with plaster, concrete, and other mat [39][20].

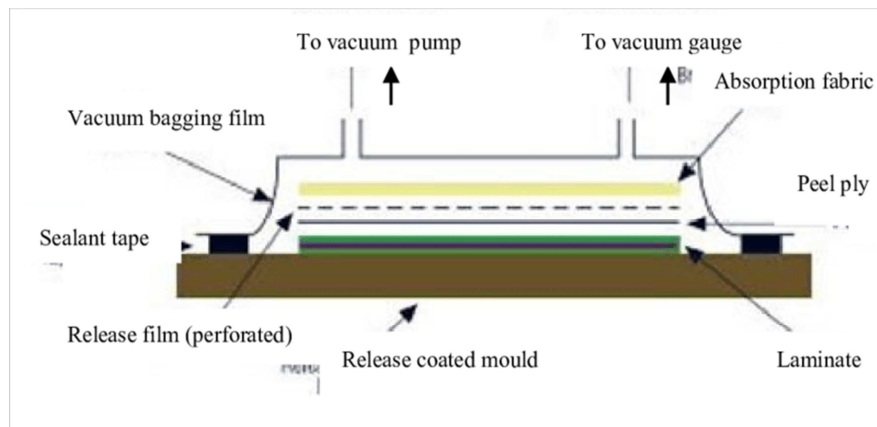

Figure 2. 11 Vacuum bagging process [14].

2.9.4 Hand lay-up on open mold

Hand lay-up is the more popular and basic open molding process used to make composites. It needed more labor but was less expensive, and it is a more efficient procedure [29]. An open mold creates solely a single side of a product. The subsequent activities are taken to complete the layout: Brushing or spraying a releasing agent is followed by a light covering of resin and another layer of reinforcing. The Fibers are then fully impregnated using rolls and a paintbrush. Layers have been placed to get the required thickness. When the product is ready, it is placed out to cure correctly. The finished item is taken from the mold after drying[8].

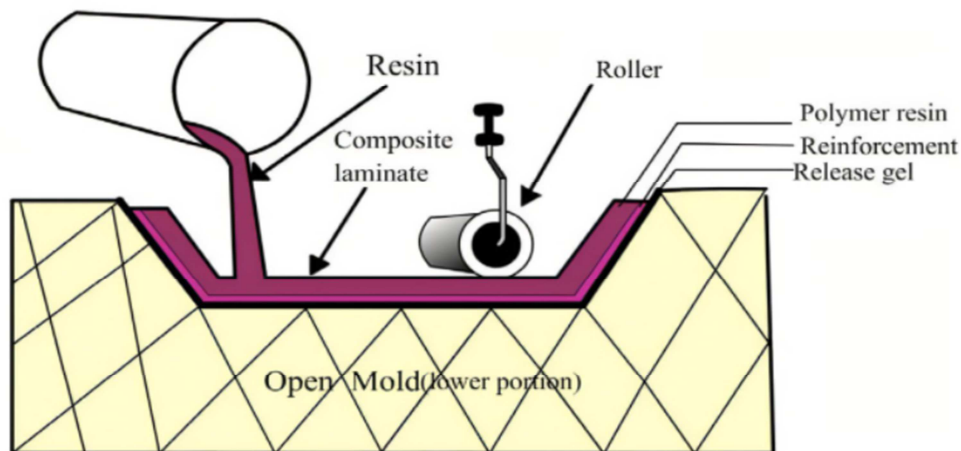

Figure 2. 12 hand layup method of composite fabrication [29].

2.10 Factors Influencing Composite Efficiency

A number of factors impact the efficiency of composite materials. Examples include fiber choices, matrix choices, fiber being loaded, fiber treatment, fiber direction, production process, and environmental conditions [7].

Natural fiber compounds' properties are greatly influenced by their mass, position, diameter, and percent of fiber. The surface condition of the fiber also influences the interaction between the fiber and the surrounding matrix. To guarantee appropriate binding, a chemical technique for removing a fiber's outer layer (such as silk and coir fiber) or pre-treatment of the fiber (such as hemp) may be required[39].

2.10.1 Treatments of natural fibers

Natural fiber treatments are necessary to alter fiber surface characteristics to improve adherence with varied substrates. The main integration issue between natural fiber and the matrix is a poor interface area caused by varied polarity contacts. Exemplary strength and stiffness may be attained by employing a solid interface, which is extremely weak in nature and has simple fracture propagation via matrix and fiber [51].

The fiber treatment mechanism is divided into two categories: (1) physical treatments to improve the qualities of natural fibers, such as strength, modulus, and elongation; and (2) chemical treatments to improve the interfacial properties of the fiber-matrix interface[52]. The effectiveness of stress transfers from the matrix to the fiber may be reduced if the contact zone is lower. The treatment's purpose is to increase adhesion between surfaces and polymer matrix suitability. This is because natural fibers include hydroxyl groups of cellulose and hemicellulose. Alkaline treatment, bleaching, acetylating, vinyl grafting, peroxide treatment, and therapy with different binding substances are some of the physical, biological, and chemical treatments that may be applied to fibers [53].

When comparing the chemical treatments stated, the most frequent chemical treatment utilized is alkali treatment, which is an inexpensive and highly efficient surface treatment that optimizes mechanical natural fiber qualities.[39].

2.10.2 Alkaline treatment

Alkaline therapy, commonly known as mercerization, is one of the most popular and easy chemical treatments. The processes of alkali treatment get rid of a portion of the cell wall's external surface, which includes hemicellulose, lignin, wax, and oils. Rougher fiber surfaces occur, which increases fiber bonding for matrix infiltration and the interaction region among the fiber and matrix. Sodium hydroxide (NaOH) is the chemical used in alkaline treatment. This approach removes hydrogen bonding in the fiber's cellulose network structure. The chemical interaction between fiber hydroxyl and sodium hydroxide is depicted here[54][52].

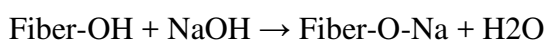

Figure 2. 13 Sodium hydroxide pellets

2.11 Extraction of Fiber

A variety of parameters, including fiber extraction process, impact the performance of natural fiber-reinforced composites. Mechanical, chemical, and biological processes are often used to remove fiber from the plant. Various procedures can be used to extract the plant's fibers[38]. Some of the extraction methods are explained below

2.11.1 Mechanical Extraction method

This extraction method can take place in the form of different processes such, as inserting water, crushing, rolling in a mill, and finning and aiding mechanical machines. To

remove fiber from the source, all of the processes indicated above were used. The primary advantage of mechanical extraction over chemical extraction is that it can be done in almost any place. High production costs are a major limitation of these methods which require higher energy usage than chemical methods. This procedure is more environmentally friendly than the chemical process[38].

2.11.2 Chemical extraction method

Acids, alkaline solutions, and catalysts are used for the chemical fiber extraction process. To change the hydrophilic to hydrophobic characteristics of natural fibers, chemical treatment is required. Chemical extraction procedures have a significant impact on the crystalline structure of fibers due to the presence of acids. The acid treatment causes reactive compounds to form and causes fibers to produce a rough surface, resulting in a higher degree of fibril crystallization. Fiber extraction with alkaline results in increased surface area and a degree of polymerization, lowering fiber breaking strength. The hydroxyl groups, which are present in both cellulose and lignin involved in hydrogen bonding within the fiber structure, are activated an alkaline treatment[26].

With these processes, the hydrogen bonds in the molecular structure of cellulose weaken, resulting in a mesh, which leads to an increase in the amount of amorphous cellulose. The cellulose structure transforms from monoclinic to polymorphism and swells as a result of this treatment, which occurs in the presence of water. Furthermore, the mercerization process improves hemicellulose and two other cellulosic fiber components' solubilize. The fiber surface becomes rougher at this step, improving the mechanical anchoring of the fiber[22][29].

2.12 Mechanical properties of composite

Mechanical properties determine a materials ability to resist mechanical pressures and stresses. On the other hand, those features are closely correlated with stress and strain. The mechanical qualities of a material govern how it responds to different loads and are used to determine its suitability for different applications. Every design engineer must be

able to choose the right materials for their project, and understanding the mechanical properties of the materials is essential for this.

The mechanical assessment of natural fiber-based polymer composites is influenced by the quantity of fiber fraction, fiber length, fiber proportion, fiber-matrix attachment, fiber position, and other parameters [55]. A number of factors were used to evaluate the mechanical characteristics of natural fiber-reinforced polymer composites.

Table 2. 2 Natural And Synthetic Fiber Mechanical Characters[56]

Fiber	Tensile strength(Mpa)	Young's modulus(Gpa)	Elongation break (%)	Density (g/cm3)
Kenaf	930	53	1.6	1.35
False Banana	355	27-32	5.9	1.34
Sisal	511-695	9-24	2-3	1.48
Jute	393-773	26.5	1.9	1.25
Bamboo	290	17	-	1.25
Hemp	550-900	70	1.6	1.48
Rise husk	200-250	-	-	-
pineapple	413-1627	60-82	14.5	1.44
Cotton	400	12	3-10	1.51
bagasse	350	22	5.8	0.89
Flax	800-1500	60-80	1.2-1.6	1.4
coconut	134.3	2.16	-	0.84
Glass fiber	345-1035	27.60	2.70-3.20	2.5

2.13 Literature related to natural fiber reinforced composite

Mehamud et al. study on Ethiopia Banana Fiber Reinforced Polymer Composites Mechanical Property Evaluation was researched. The authors generated four samples: 5% banana fiber with 95% epoxy resin, 10% banana fiber with 90% epoxy resin, 15% banana fiber with 85% epoxy resin, and 20% banana fiber with 80% epoxy resin. The researchers observed that 20% banana fiber and 80% epoxy resin had a tensile strength of 56.5 MPa, 15% banana fiber had 47.4 MPa, 10% banana fiber had 42.6 MPa, and 5% banana fiber had just 37.8 MPa. The tensile strength of cloth rises as the fiber becomes more concentrated. In his impact tests, he determined that 20% and 15% banana uni-directional scored bending strength, and the 20% banana fiber/ epoxy unidirectional demonstrates 340.625 MPa, which is greater than the remaining banana fiber proportions[57].

M. Ramesh et al. The mechanical characteristics of banana fiber-reinforced polymeric composites have been analyzed and processed using 40% banana fiber + 60% epoxy resin, 50% banana fiber + 50% epoxy resin, and 60% banana fiber + 40% epoxy resin. The tensile strength of 50% banana fiber + 50% epoxy resin was shown to be better than the two remaining composites in this investigation, while both the bending and impact resistance scored greatest with 60% banana fiber + 40% epoxy resin[58].

A. Betelie et. al. The resilience to fracture characteristic of a sisal-reinforced epoxy composite was examined utilizing a fracture resistance evaluation approach with a stress concentration factor. For reinforcing, shredded sisal fibers were employed. Flax-Sisal Fiber Reinforced Composites Epoxy Building, Evaluation, and Simulations. The samples were created using an epoxy resin (AY-105) as a matrix, a hardener (HY-951) as a hardener, and sisal fiber with 15%, 25%, 30%, 35%, and 40% fiber weight fractions with arbitrary positions using Hand lay-up manufacturing approach. The sisal content of 30% indicated excellent fracture. It was found that employing chopped sisal fibers as epoxy reinforcement might result in the effective production of a lighter composite material with excellent strength and stiffness[59].

Muniappan et al. The effect of coffee bean reinforcement (5, 10, 15, 20, 25, and 30%wt) on the mechanical characteristics of the epoxy composite was investigated. A 25%

weight percentage of coffee bean natural filler composite produced the best mechanical characteristics. Because of the consistent dispersion of coffee beans in an epoxy matrix, fracture resistance rises with the addition of coffee bean additive, and stress is distributed evenly. It also suggests that the connection between the filler and the substrate is stronger, and the 30% weight fraction of the filler has less moisture content with the epoxy matrix in the composite[60].

Huang et al. The investigator reinforced the thermoplastic-based composite using coffee husk fibers. The research focused on the chemical constitution and thermal characteristics of CHF and WF, and the findings revealed that they had identical characteristics. The insertion of coffee husk fiber inside the HDPE matrix enhanced the modulus and thermal characteristics of the composite but also lowered its resistance to moisture. [5].

2.14 Related Literature on hybrid composite

T. Hariprasad et. Al, Hybrid banana-coir fiber epoxy composites are compared and assessed in terms of mechanical characteristics. Both treated and untreated banana-coir fibers are tested for tensile, flexural, and impact characteristics. Untreated fiber composites offer higher flexural strength than treated fiber composites, according to tensile and impact testing. The characteristics of the banana-coir and matrix were assessed under various loading scenarios using the finite element analysis (FEA) program ANSYS[61].

Luna. G. Flax-Sisal Fiber Reinforced Epoxy Hybrid Tensile, flexural, compression, impact, and water absorption characteristics of composite materials for prosthetic sockets were examined. Hand-layup was utilized to create samples with 3cm fiber length and fiber-matrix weight proportions of 40-60, 30-70, and 35-65 in accordance with ASTM specifications for each treated and untreated fiber. The treated composite with F25%-S15%-E60% displayed outstanding mechanical and physical characteristics, namely tensile strength of 68.40MPa, bending strength of 145.7MPa, compression strength of 45.64MPa, impact energy of 10.83J, and moisture absorption rate of 3.66%[22].

R. Rana et. al, The epoxy matrix was reinforced with a sisal and glass fiber hybrid in this investigation. To increase the interface adhesion across fiber and matrix, sisal fiber was chemically treated with acetylene. Two stable layers of glass fiber reinforced with epoxy matrix composite with variable concentrations of sisal fiber (0, 2%, 4%, and 6%). As a result, as the sisal fiber composition decreased, tensile and flexural strength increased by 4%[62].

M. Ghasemzadeh et. al, The mechanical and aging characteristics of flax-glass fiber reinforced polypropylene hybrid composites were studied. Glass fiber improved tensile strength and resilience to impact while having no effect on grain yield or failure elongation. Glass fibers increase the moisture resistance of polypropylene/flax composites, according to the results of the experiments. Glass fiber increases the deterioration of the polypropylene matrix in extended UV aging studies, while flax fiber protects the composites[63].

Santosh M. et. al, The researchers investigated a hybrid composite of flax and sisal with an epoxy matrix. The numerous compositions utilized are as follows: 20% Sisal, 5% Flax, and 75% Cotton. Other Compositions are 20% Sisal, 10% Flax, 70% Epoxy and 20% Sisal, 15% Flax, 65% Epoxy. The composite was created by hand layup. Tensile, compression, and flexural strength were all evaluated. Tensile, compression, and flexural strength were found to be grater for the mixture of 20% sisal+15% flax+65% epoxy resin and less for the mixture of 20% sisal+5% flax+75% epoxy resin. It was discovered that the proportion of sisal and flax increases the tensile, compression, and flexural strength [9] .

Nayak et. al, The impact of adding bamboo-glass fiber reinforcements to a polypropylene matrix (BGRP) was investigated. There were contrasts between the BGRP and virgin polypropylene. As a factor, fiber weight was used. The composites prepared at 30% fiber proportion and 2% MAPP volume demonstrated the best mechanical characteristics. Tensile strength, flexural strength, and impact strength improved by approximately 69%, 86%, and 83%, accordingly, in comparison to virgin polypropylene

at a glass fiber: bamboo percentage of 15:15. In addition, reduced fiber disengagement was seen in hybrid composites compared to BGRP[64].

2.15 Literature related to bumper

Prabhakaran, C. et. al, This research focuses on the design, manufacturing, and evaluation of steel and composite bumpers. They also investigated the two bumpers' weight, fuel economy, cost, and resilience to impact. As a result, a steel bumper weighs 5.15kg, and a composite bumper weighs 2.38kg for the same bumper type. This shows that the proportional ratio of composite bumper is 53.8% lower than the steel bumper, leading to in higher vehicle fuel economy. Composite materials are more economical than metallic ones since the cost of a composite bumper is 80% less than the cost of a steel bumper[65].

M. Anil . et. al, study of a bumper simulated at various speeds for various materials Steel, ABS plastic, and carbon fiber-reinforced plastic are all options. The authors investigate a 3D automobile bumper created in modeling tool Pro/Engineer and do an impact investigation on the bumper at three distinct speeds: 48 km/hr, 75 km/hr, and 150 km/hr. Carbon strengthened has less than steel, which means the stress ratings are less, and when the results are compared, the stress amounts for the composite are less. Finally, the researchers proposed that composite materials are superior compared to steel for automotive bumpers[66].

2.16 Literature related to fiber loading and volume ratio

Idiris et al. The mechanical characteristics of epoxy resin composites reinforced with Ethiopian banana fibers were investigated. Acetone was used to treat banana fibers, and the fiber-to-resin ratios were 5/95, 10/90, 15/85, and 20/80%. The composite panels were made using a manual lay-up technique, and the curing procedure took 24 hours at 30°C. The samples were subjected to mechanical testing and microstructural examination. According to the test findings, a fiber-to-resin ratio of 20/80% gives superior mechanical qualities than other ratios. Composites with fiber content have shown a linear improvement in tensile strength, flexural strength, and impact strength[57].

Sushirowati, et al. The mechanical characteristics of pineapple leaf fiber epoxy composites were investigated in terms of fiber weight and fiber length. Fiber-to-matrix ratios ranged from 10/90 to 20/80, 30/70, and 40/60. The fiber length was varied between 20mm, 30mm, and 40mm. To increase interfacial bonding between the fiber and matrix, a 5% NaOH treatment is used. The composite was created using a hand lay-up approach. As the fiber concentration climbed to 30%, the mechanical characteristics enhanced. Tensile strength, flexural stiffness, and impact strength all drop as the fiber content exceeds 30%. In general, the mechanical qualities of 30/70% of 40 mm fiber length are the best. This suggests that fiber content and fiber length have a significant impact on composite characteristics[67].

Mohanty et al. Jute fiber-reinforced polypropylene composites with 5% maleic anhydride as an adhesion enhancer and fiber loading ranging from 10% to 40% were investigated. The study discovered a linear rise in impact strength from 10% to 30% fiber loading, followed by a reduction at 40% fiber loading. It should be noted that fiber adaptation, chemical composition, and immersion duration all have a significant impact on the mechanical characteristics of composites[68].

Augustine et al. The tensile strength of epoxy resin composites reinforced with banana fibers for prosthesis was investigated. The fiber-to-resin proportions were 10%, 20%, 30%, 40%, and 50%. For 30 minutes, banana fibers have been treated with 90% alcohol. Tensile strength and elastic modulus are excellent when the fiber volume percentage is 40%, depending on test findings. Furthermore, when compared to previous research, this banana fiber composite was in the center of the pack[69].

Araya et al. The fracture resistance characteristics of chopped sisal-epoxy composites were investigated. The fibers were taken from sisal leaves and cut into 2mm, 10mm, and 15mm pieces. The epoxy resin-hardener ratio is 10:1, and the fiber-to-resin volume proportions were 15/85, 25/75%, 30/70%, 35/65%, and 40/60%, respectively. Hand layup was used to saturate the fibers with resin before compression molding. The fracture resistance test was investigated. At 30/70%, the experimental study shows good fracture resistance and other mechanical parameters[59].

Basij et al. The author demonstrates how the mechanical characteristics of wood pulp-polypropylene composites are affected by fiber length and fiber concentration. Wood pulp, chopped fiber, and polypropylene grafted with maleic anhydride were used to create a composite. Short (2 mm) fiber lengths of wood pulp were arranged. Fiber contents of 27%, 37%, and 47% were also created, and the fiber, resin, and curing agent were combined by employing a twin-screw extruder at 50 rpm and 180°C to manufacture composites via injection molding. Tensile strength, tensile modulus, and flexural strength all improved with increasing fiber length and fiber load, while impact strength dropped[69].

According to the explanations in the literature, fiber composition, fiber loading, and fiber length, all have a significant impact on the characteristics of composites. However, because some of the findings grew linearly while others declined marginally, the parameters did not have as much of an impact on them. This illustrates that the change in composite characteristics is affected by fiber type, manufacturing process, and component element volume percent. Enset-Coffee husk fibers were hybridized with nine sub-compositions of 60/40%, 70/30%, and 80/20% for the current work. This composition variation was utilized to investigate the influence of fiber on matrix volume fraction.

2.17 The Knowledge Gap:

According to a thorough analysis of the literature, hybrid composites offer tremendous promise as innovative materials in a range of industries, including structural, automotive, aerospace, and marine applications. Natural fibers are gaining popularity among academics, specialists, engineers, and researchers all around the world, replacing conventional materials like cotton. Natural fiber-reinforced composite materials are increasingly being used in the aerospace, automotive, marine, and civil engineering industries..

- A substantial number of experiments have been undertaken on both natural fibers. However, there was little research on the hybridization of natural fibers, particularly the Enset and coffee husk hybrid.

- Most studies on Enset fiber exhibited long fiber with woven configuration. There have been few experiments using chopped fibers in a random configuration.
- Enset fiber is primarily a mix of synthetic fiber and natural fiber; similarly, Coffee Husk fiber is mostly utilized for fertilizer and compost rather than structural applications.

Chapter Three

Materials and Methods

3.1 Methodology of the Research

To tackle the topic, many methods of analysis and data collecting were applied.

Literature Review: This was accomplished by gathering and assessing numerous papers, periodicals, and books on composites, natural fibers, and hybrid fibers. It will be urged to get a better grasp of challenges and solutions, as well as how to attain your research objectives.

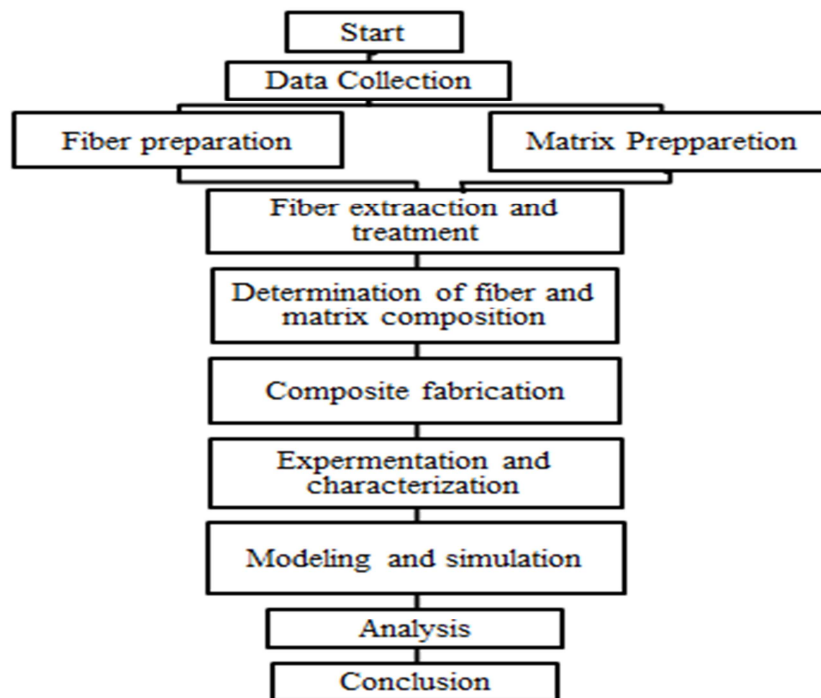

Figure 3. 1 Methodology

Plant selection criteria are obvious; Natural fiber qualities are influenced by the plant's age/maturity, soil type, and location. As a result, the selected enset and coffee husk fiber plant were collected.

Designing fiber matrix composition: several fiber matrix compositions and fiber-fiber loadings were chosen based on various literatures.

Selection of treatment: NaOH is mostly used to treat natural fibers in order to improve the bond between the fibers and the matrix, as well as to bleach and clean the surface of natural fibers.

Method of fabrication: There are several techniques for creating composite materials. This comprises hand layup, resin transfer, compression molding, and vacuum bagging-assisted hand lay-up techniques. In this investigation, hand layup accompanied by compression was utilized as a drying technique due to its low complexity.

Fabrication of natural hybrid composite: The epoxy, hardener, alkali agent, mold, and releasing agent were all prepared during this phase, and nine composite samples of various compositions were fabricated.

Experiment setup and execution: the nine fabricated composite specimens were prepared in accordance with ASTM specimen standards, and these specimen samples were tested for physical (water absorption) and mechanical tests (Tensile, Flexural, impact, and compression).

3.2 Materials Used

In this work, two distinct kinds of fiber have been utilized as reinforcement, and a synthetic epoxy polymer was used as the base material to construct the composite. The selection of both fibers is due to their availability in local market and the utilization of coffee husk fiber for usable products will decrease the pollution due to coffee processing wastes. This composite material is being researched as a replacement for the usual material utilized for producing composite Qute bumpers, as well as to boost waste recycling.

Epoxy is a resin that is extensively used in the production of composites with various reinforcing elements. Their widespread use is owing to their inexpensive cost, outstanding efficiency, and simplicity of manufacturing[24]

To build and analyze the composite, various fiber matrix arrangements, supplies, and tools were employed. Nine fabricated composite specimens were studied in this study. These composites are made from two different fiber reinforcements and a polymer matrix that has been treated with %NaOH. Enset and coffee husk fibers were the two reinforcing fibers studied [40][29]. Epoxy resin is the polymer matrix used in this thesis. The following materials were used in this study:

Table 3. 1 Materials used in the study

Material/equipment	
Enset fiber	Mold (320mm*300mm*25mm)
Coffee husk fiber	Releasing agent
Epoxy resin	Plastic sheets (<i>Low density polyethylene</i>)
Hardener	brush
NaOH	Hack saw

3.3 Fiber Collection and Extraction

Several researchers have created composite board using various natural fibers and matrix materials. The compositions and other processes used by one researcher may differ from those used by another. Throughout the selection process, the following factors were considered: strength to weight ratio, availability, mechanical Strength as an individual fiber and as a hybrid, simplicity of manufacture, and physical properties are all important considerations. This study was conducted in Ethiopia and takes into account the local conditions. Despite the fact that the combination of selected fibers (enset and coffee husk) has not been broadly explored in Ethiopia, the fibers chosen have desirable qualities and are readily available. In Ethiopia, enset and coffee husk are primarily not employed for current applications. Instead, Enset plants are utilized to construct ropes, mats as a home fence, and coffee plants are composted. The chosen fibers outperform other natural fibers in terms of mechanical qualities [32].

3.3.1 Enset Fiber

The Enset plant bast (a pseudo-stem Leaf shafts wrapped tightly around each other) was harvested in Dilla Ethiopian town of Gedeo. Dilla is an SPNN Ethiopian town situated 360 kilometers south of Addis Ababa on the main asphalt route to Moyale. By cutting the plant at the base, mature Enset plant bast with longer lengths were gathered. The most common and earliest process for extracting fiber from the leaves consists of two major processes: initially, detaching the fibrous outermost layer from every leaf sheath, and next, discarding mushy substances and thereby releasing the fiber bundles from the tuxy. After the fiber is extracted, it is washed for one to two hours in clean water to remove any undesirable particles. After that, the cleaned fiber is dried in the open air for two to three days depending on the availability of sunlight in the sun. Then the fiber is treated with sodium hydroxide solution and chopped using seizers to required length[70].

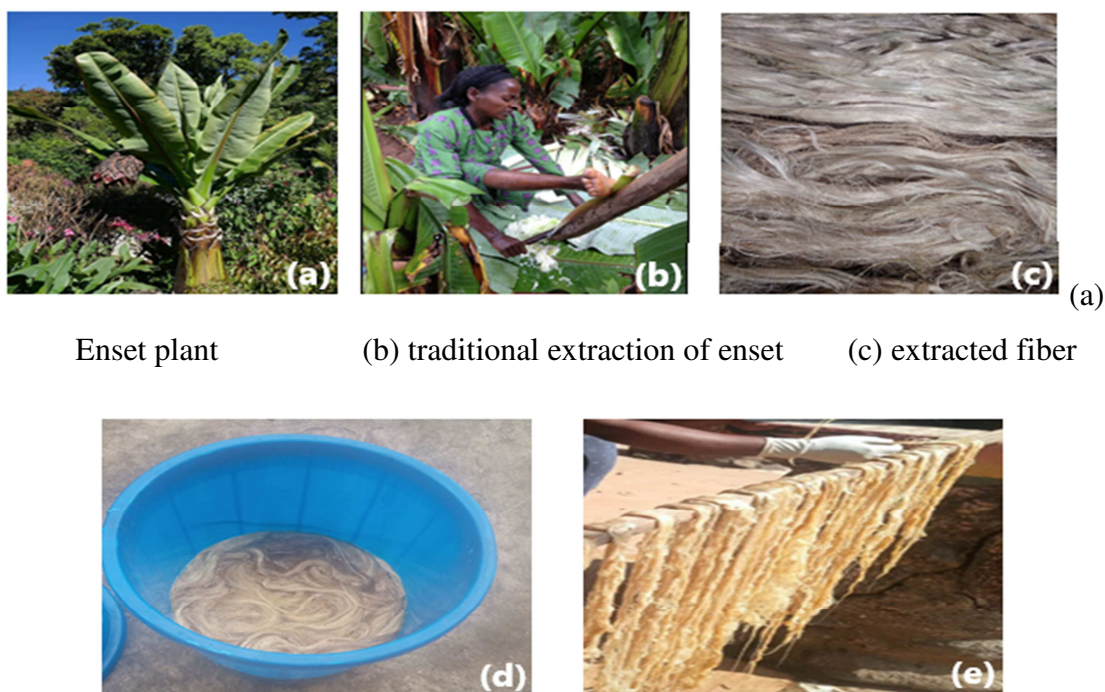

Enset plant (b) traditional extraction of enset (c) extracted fiber

(d) enset fiber soaked in NaOH solution (e) drying soaked enset fiber by to sun light
Figure 3. 2 Extraction of enset fiber and treatment (a) Enset plant, (b) traditional extraction of enset, (c) extracted fiber, (d) enset fiber soaked in NaOH solution, (e) drying soaked enset fiber by sun light.

Density: Pycnometer was used to determine the density of both Enset and coffee husk fiber. A pycnometer is a device that determines density by using a liquid having a recognized density, such as water.[13] To compute the density of fibers in this thesis, water was used. To determine the specific gravity/ density of the fibers pycnometer's was used. The following steps are used.

- a) Measure the weight of the empty pycnometer = W_1
- b) Measure the weight of the pycnometer + water = W_2
- c) Measure the weight of the pycnometer + sample + water = W_3
- d) Measure the weight of the pycnometer + water = W_4

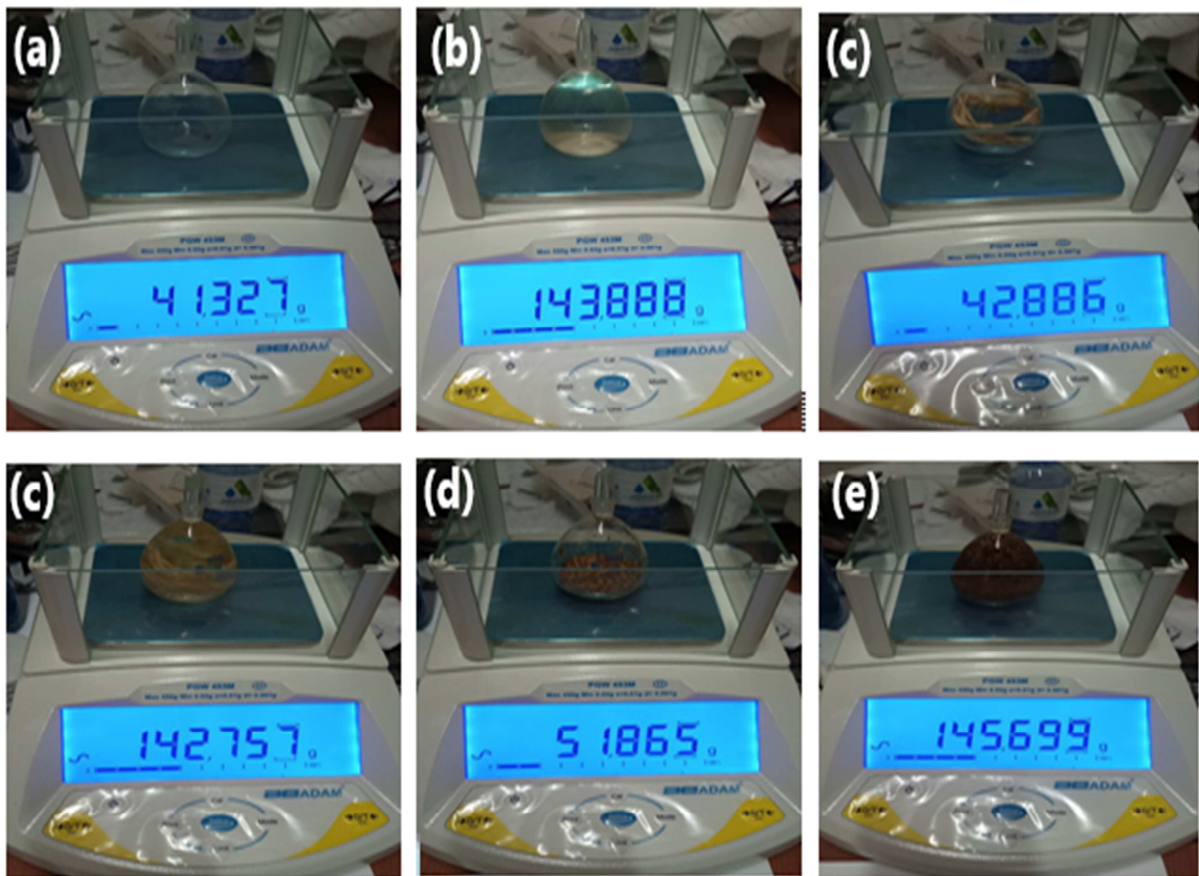

Figure 3. 3 Finding the density of both fibers a) Weight of the empty pycnometer (b) Weight of the pycnometer + water (c) Weight of the pycnometer + Enset fiber (d) Weight of the pycnometer + Enset fiber + water (e) Weight of the pycnometer + coffee husk fiber (f) Weight of the pycnometer + coffee husk fiber + water

Since ; *specific gravity of solid* = $\frac{\text{weight of solid}}{\text{weight of water}}$

$$\rho_s = \frac{W_s}{W_w} \dots \dots \dots (3.1)$$

The density of the specimen was determined based on the observed weight as follows;

$$W_s = W_2 - W_1 \dots \dots \dots (3.2)$$

Because the weight of water and the weight of sold that have the same volume are equal.

Thus; $W_3 - W_4 = W_s - W_w \dots \dots \dots (3.3)$

By substituting for W_s from equation (3.2) in to equation (3.3) and we have;

$$W_w = (W_2 - W_1) - (W_3 - W_4) \dots \dots \dots (3.4)$$

Here, substituting equ(3.2) and equ.(3.4), the density of the sample is given by;

$$\rho_s = \frac{W_2 - W_1}{(W_2 - W_1) - (W_3 - W_4)} \dots \dots \dots (3.5)$$

Density of enset fiber

- a) Weight of the empty pycnometer = $W_1 = 41.3279$ gram
- b) Weight of the pycnometer + Enset fiber = $W_2 = 42.886$ gram
- c) Weight of the pycnometer + Enset fiber + water = $W_3 = 142.757$ gram
- d) Weight of the pycnometer + water = $W_4 = 143.888$ gram

Thus

$$\rho_E = \frac{W_2 - W_1}{(W_2 - W_1) - (W_3 - W_4)} = \frac{42.886 - 41.3279}{(42.886 - 41.3279) - (142.757 - 143.888)}$$

$$\rho_E = 0.579\text{g/cm}^3$$

Density of coffee husk fiber

- a) Weight of the empty pycnometer = $W_1 = 41.3279$ gram
- b) Weight of the pycnometer + coffee husk fiber = $W_2 = 51.865$ gram

- c) Weight of the pycnometer + coffee husk fiber + water = W3 = 145.699 gram
- d) Weight of the pycnometer + water = W4 = 143.888 gram

Thus

$$\rho_E = \frac{W_2 - W_1}{(W_2 - W_1) - (W_3 - W_4)} = \frac{51.865 - 41.3279}{(51.865 - 41.3279) - (145.699 - 143.888)}$$

$$\rho_E = 1.207\text{g/cm}^3$$

3.4 Matrix Material

3.4.1 Epoxy Resin

The matrix decides the composite's operational circumstances. Epoxy resins are among the greatest frequently utilized thermoset polymer matrices. This is because of their outstanding binding, high temperature performance, increased mechanical and electrical qualities, low shrinkage, extended working duration, chemical resistance, anti-corrosion properties, economical pricing, minimal viscosity, extended pot duration at ambient temperature, and simplicity of fabrication. [10][20]. The epoxy resin used in this thesis was AY-105, which was purchased locally. It has the following property;

Table 3. 2 Property of the epoxy resin used[59].

Specification	Epoxy Resin AY-105
Color	Dark blue
Viscosity @250C	10,500 – 12,000 Mpa S
Density @ 250C	1.10-1.2g/cm3

3.4.2 Hardener

It is necessary to add catalyst to the epoxy before it can be used. The catalyst hardens the epoxy by initiating a chemical reaction that converts its state from a fluid to a solid. A precise amount of hardener should be applied to obtain superior mechanical characteristics [21].The hardening catalyst used here is HY951, which is readily available.

3.5 Preparation of Epoxy and Hardener Mixture

To improve the mechanical, thermal, and physical properties of the composite, the right amount of mixture must be used. A mixture of epoxy AY-105 and hardener HY951 is used to make the composite. The two components were combined in a 10:1 epoxy-hardener weight ratio. They were poured into the Bowl after properly correcting the combination composition and thoroughly swirled to fully combine them and avoid air bubbles.

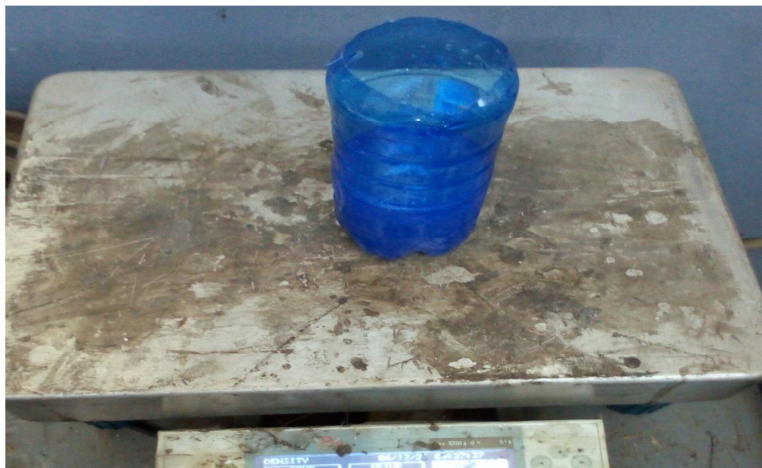
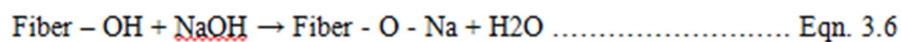

Figure 3. 4 Mixture of epoxy and hardener

3.5.1 Fiber Treatment

Fibers can be treated in a variety of ways to change their properties. In this thesis, the treatment known as Mercerization or Alkaline treatment was employed. For the treatment of fibers, a solution of sodium hydroxide (NaOH) is utilized for knocking down hydrogen bonds in the chain structure.



It also eliminates the amount of oil and lignin. It is also the most basic chemical-based treatment method. The subsequent process happens during mercerization:[52][71].

For both Enset and coffee husk fiber, NaOH concentration was utilized. The treatment was carried out at Ethiopia, Dilla University School of food and Chemical Engineering.

The alkaline solution was made by mixing NaOH pellets with water and stirred deeply for uniform mixing. Depending on the NaOH percentage concentration required, different calculations were performed to properly mix the two. As a result, by employing a weight balance, the proper weight was determined, and the correct volume of water was placed in a plastic container.

3.5.2 Treatment of Both Enset and Coffee Husk Fiber

Before being processed, Enset fiber was repeatedly cleaned with standard and purified water to eliminate debris sticking to the fiber's exterior. The required volume of NaOH and H₂O is then combined in a plastic container. 8% NaOH was used in this case. The study found that an 8 percent NaOH treatment for 8 hours increased tensile and flexural strength. 240g of NaOH and 10L of water were thoroughly mixed.[35].

The cleaned Enset fiber was immersed in a solution of sodium hydroxide for 8 hours after being mixed. The fiber was then removed, rinsed, and cleansed with distilled water until the chemical was neutralized. The cleaned fibers were then spread out in the sun to dry. Finally, the treated fiber was used to construct the hybrid composite.

The same process as for coffee husk fiber treatment was followed, but the amount of NaOH in the solution was decreased to 5%, and the coffee husk fiber was immersed in the NaOH solution for 24 hours[71]. Then the fiber was repeatedly splashed by standard water for removing chemicals on the surface and dried by sunlight before used to fabricate the composite.

3.6 Preparation of Mold

The mold was created based on the size, number of test specimens, and number of tests. As a result, the mold was designed to be 320 x 270 x 4mm in size. Steel was used in the mold's construction. The mold is made up of a bottom plate and an upper plate. The bottom sheet was built of rectangular metal sheets with four RHS steel frames attached to

it. The interior of the bottom sheet is the same as the size of the interior of the mold. The top layer was constructed from metal strips and a hollow cylindrical block linked to four wings. During curing, the block and four wings are employed to spread the weight delivered by the compressor. To simplify the deployment of the full composite, another movable metal strips measuring 320 x 270 x 1mm was utilized. The top plate also serves as a composite cover.

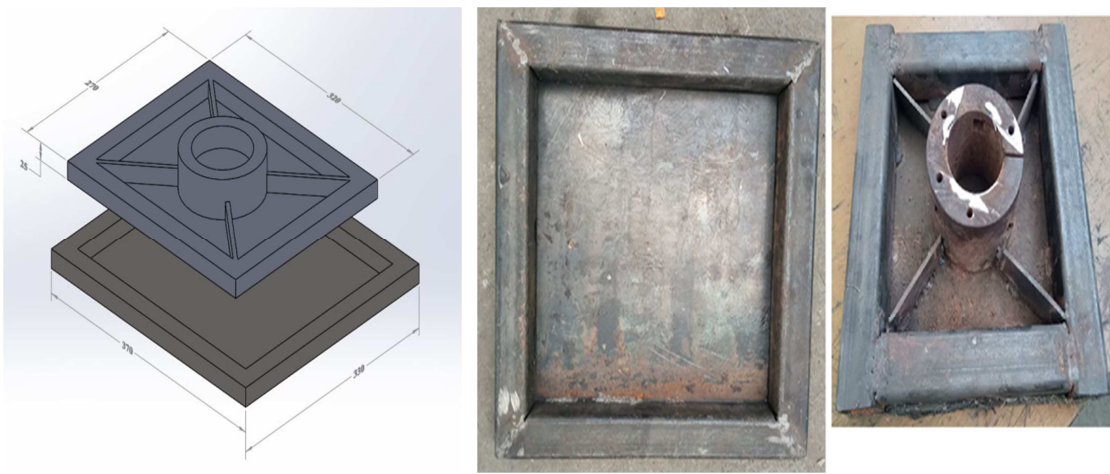

Figure 3. 5 Mold design and fabricated mold with 320mm x 270mm and depth of 25mm.

3.7 Fabrication of the Hybrid Composite

Enset and coffee husk fibers serve as reinforcement, and epoxy serves as the matrix in this hybrid composite. The Enset fiber is cut into 3-8mm pieces, while the coffee husk fiber is granulated into 0.5-1.8mm pieces. The matrix epoxy (AY-105) is fully combined with the hardener (HY-951). Calculating the mass required for each fiber and matrix under nine proportion is part of the fabrication of the hybrid composite.

Hand-layup is used to create all of the composites. Because of its low cost and ease of use, the Hand Layup technique is commonly used. The reinforcing material (typically natural fibers) is inserted in the mold and then saturated with epoxy resin using a brush during the hand lay-up procedure. So, a composite sample for the test was prepared by this method [42]. The composition and mass of each composite ingredient are used to mix them.

Table 3. 3 Determination of fiber and matrix weight ratio for the enset coffee husk hybrid composite

Composite /sample	Fiber –matrix %		Enset- coffee husk %	
1	20	80	10	10
2	20	80	5	15
3	20	80	15	5
4	30	70	15	15
5	30	70	20	10
6	30	70	10	10
7	40	60	20	20
8	40	60	30	10
9	40	60	10	30

Table 3. 4 Composite sample one volume fraction and Mass composition

Composite sample one volume fraction and Mass composition		
<i>composition %(80 :20) matrix = 80%, Enset fiber = 10%, and coffee husk = 10%</i>		
Total Mass of C1 = 306.72 g	Volume of matrix = 230.4 cm ³	Volume of fiber = 57.6 cm ³
Density of C1 = 1.065 g/cm ³ .		
Volume of Enset fiber = 28.8 cm ³	Volume of Coffee husk fiber = 28.8 cm ³	
Mass of enset fiber = 16.6752 g	Mass of coffee husk fiber = 16.6752 g	
Mass of Epoxy resin = 255.2832g	mass of hardener = 22.97 g	

Table 3. 5 Composite sample two volume fraction and mass composition

Composite sample two volume fraction and Mass composition		
<i>composition %(80 :20) matrix = 80%, Enset fiber = 5%, and coffee husk = 15%</i>		
Total Mass of C2 = 315.7632 g	Volume of matrix = 230.4 cm ³	Volume of fiber = 57.6 cm ³
Density of C2= 1.0964 g/ cm ³		
Volume of Enset fiber = 14.2 cm ³	Volume of Coffee husk fiber = 14.4 cm ³	
Mass of enset fiber = 8.3376 g	Mass of coffee husk fiber = 52.1424 g	
Mass of Epoxy resin = 255.2832g mass of hardener = 22.97 g		

Table 3. 6 Composite sample three properties and mass required

Composite sample three volume fraction and Mass composition		
<i>composition %(80 :20) matrix = 80%, Enset fiber = 15%, and coffee husk = 15%</i>		
Total Mass of C3 = 297.6768 g	Volume of matrix = 230.4 cm ³	Volume of fiber = 57.6 cm ³
Density of C3 = 1.0336 g/ cm ³		
Volume of Enset fiber = 43.4 cm ³	Volume of Coffee husk fiber = 43.2 cm ³ .	
Mass of enset fiber = 25.0128 g	Mass of coffee husk fiber = 17.3808 g	
Mass of Epoxy resin = 255.2832g mass of hardener = 22.97 g		

Table 3. 7 Composite sample four properties and mass required

Composite sample four volume fraction and Mass composition		
<i>composition %(70 :30) matrix = 70%, Enset fiber = 15%, and coffee husk = 15%</i>		
Total Mass of C4 = 300.528 g	Volume of matrix = 201.6 cm ³ .	Volume of fiber = 86.4 cm ³ .
Density of C4 = 1.0435 g/ cm ³ .		
Volume of Enset fiber = 43.2 cm ³	Volume of Coffee husk fiber = 43.2 cm ³ .	
Mass of enset fiber = 25.0128 g	Mass of coffee husk fiber = 52.1424 g	
Mass of Epoxy resin = 223.3728 g	mass of hardener = 20.09 g	

Table 3. 8 Composite sample five properties and mass required

Composite sample five volume fraction and Mass composition		
<i>composition %(70 :30) matrix = 70%, Enset fiber = 20%, and coffee husk = 10%</i>		
Total Mass of C5 = 291.4848 g	Volume of matrix = 201.6 cm ³ .	Volume of fiber = 86.4 cm ³ .
Density of C5 = 1.0121 g/ cm ³		
Volume of Enset fiber = 57.6 cm ³	Volume of Coffee husk fiber = 28.8 cm ³	
Mass of enset fiber = 33.3504 g	Mass of Cofee husk fiber = 34.7616 g	
Mass of Epoxy resin = 223.3728 g	mass of hardener = 20.09 g	

Table 3. 9 Composite sample six properties and mass required

Composite sample six volume fraction and Mass composition		
<i>composition %(70 :30) matrix = 70%, Enset fiber = 10%, and coffee husk = 20%</i>		
Total Mass of C6 = 309.5721 g	Volume of matrix = 201.6 cm ³ .	Volume of fiber = 86.4 cm ³ .
Density of C = 1.0749 g/ cm ³ .		
Volume of Enset fiber = 28.8 cm ³	Volume of Coffee husk fiber = 57.6 cm ³ .	
Mass of enset fiber = 16.6752 g	Mass of Cofee husk fiber = 69.5232 g	
Mass of Epoxy resin = 223.3728 g	mass of hardener = 20.09 g	

Table 3. 10 Composite sample seven properties and mass required

Composite sample seven volume fraction and Mass composition		
<i>composition %(60 :40) matrix = 60%, Enset fiber = 20%, and coffee husk = 20%</i>		
Total Mass of C7 = 294.336 g	Volume of matrix = 172.8 cm ³ .	Volume of fiber = 115.2 cm ³ .
Density of C7 = 1.022 g/ cm ³ .		
Volume of Enset fiber = 57.6 cm ³	Volume of Coffee husk fiber = 57.6 cm ³	
Mass of enset fiber = 33.3504 g	Mass of Cofee husk fiber = 69.5232 g	
Mass of Epoxy resin = 191.4624 g	mass of hardener = 17.231 g	

Table 3. 11 Composite sample eight properties and mass required

Composite sample eight volume fraction and Mass composition		
<i>composition %(60 :40) matrix = 60%, Enset fiber = 30%, and coffee husk = 10%</i>		
Total Mass of C8 = 276.2496 g	Volume of matrix = 172.8 cm ³ .	Volume of fiber = 115.2 cm ³ .
Density of C8 = 0.9592 g/ cm ³		
Volume of Enset fiber = 86.4 cm ³	Volume of Coffee husk fiber = 28.8 cm ³ .	
Mass of enset fiber = 50.0256 g	Mass of Cofee husk fiber = 34.7616 g	
Mass of Epoxy resin = 191.4624 g	mass of hardener = 17.231 g	

Table 3. 12 Composite sample nine properties and mass required

Composite sample seven volume fraction and Mass composition		
<i>composition %(60 :40) matrix = 60%, Enset fiber = 10%, and coffee husk = 30%</i>		
Total Mass of C9 = 312.4224 g	Volume of matrix = 172.8 cm ³ .	Volume of fiber = 115.2 cm ³ .
Density of C1 = 1.0848 g/ cm ³ .		
Volume of Enset fiber = 28.8 cm ³	Volume of Coffee husk fiber = 86.4 cm ³ .	
Mass of enset fiber = 16.6752 g	Mass of Cofee husk fiber = 104.2848 g	
Mass of Epoxy resin = 191.4624 g	mass of hardener = 17.231 g	

Table 3. 13 The overall mass required for nine composites is mentioned below.

No.	Mass Enset Fiber (Gram)	Mass of Coffee Husk Fiber (Gram)	Mass of Epoxy Resin(Gram)	Total
C1	16.6752	34.7616	255.2832	306.72
C2	8.3376	52.1424	255.2832	315.7632
C3	25.0128	17.3808	255.2832	297.6768
C4	25.0128	52.1424	300.528	377.6832
C5	33.3504	34.7616	300.528	368.64
C6	16.6752	69.5232	300.528	386.7264
C7	33.3504	69.5232	191.4624	294.336
C8	50.0256	34.7616	191.4624	276.2496
C9	16.6752	104.2848	191.4624	312.4224
Total	225.1152	469.2816	2241.8208	2936.218

3.8 Preparation of Enset and Coffee Husk Fiber

Treated Enset fibers are cut into 3-8mm fiber lengths and 0.2-1.8mm coffee husk fiber lengths for the production of nine hybrid composites. All nine composites use the same length of fiber. The two fibers were determined and mixed together to determine the content of the produced composite. Stirring will assist in the uniform dispersion of the two fibers into one another.

3.9 Fabrication of Composites Specimen

The hand lay-up technique is utilized in the manufacturing process. This is the most straightforward approach for fabricating composite materials. The process requires the fewest ingredients when compared to other approaches. Before starting production, prepare the mold, roller, brush, plastic sheet, releasing agent, glove, chopped fibers, and epoxy-hardener mixture. Cleaning the mold was the initial step in the fabrication process. The mold was cleaned, and Two polyethylene sheets were inserted to enclose the uncovered portion of the mold. on a clean table. The bottom of the cavity should have one plastic sheet and the top should have the other. After prepping the plastic sheet, it

was coated with a releasing agent. The bottom plastic was then properly placed over the needed mold area.

Following that, a blend of Epoxy – Hardener and fiber with the required weight composition was made. The Epoxy – Hardener was combined at a 1:10 ratio, as stated before. According to each composite, the epoxy has its own weight. As a result, the epoxy was weighed using a scale, and the hardener was measured and thoroughly mixed with a stirrer in a 1:10 ratio. Air bubbles were avoided to the greatest extent possible in this case. Furthermore, according to the nine compositions, Enset and coffee husk fiber have their unique weight. As a result, each fiber's weight was measured using a scale in order to prepare it for fabrication. Following the measurement, the fibers were blended by hand with a stirrer to evenly distribute their contents.

A slight volume of Epoxy - Hardener mixture was then poured on prepared plastic sheet with a brush and evenly distributed throughout the mold. Following that, the matrix is filled with some of the prepared and blended fibers. After that, a tiny amount of pressure was exerted with the support of a roller to impregnate the fiber uniformly. The procedure of applying epoxy, mixing fiber, and rolling it out was repeated until the fiber combination was complete. The last coating of epoxy-hardener combination was then dispensed on top of the last addition of fiber mixture. Then, once more, the roller application was carried out.

The second waxed plastic sheet was then put to the top of the composite when this process was completed. Plastic sheets also aid in achieving a good end product surface finish. The plastic sheet was wetted uniformly with a clean roller, which also served to discharge excess epoxy glue. Following the application of a roller to the surface of the composite, the lid or upper part of the mold was encased for the last stage. This completely encased the composite. The material was then compressed and cured in a hydraulic press machine that applied a uniform stress of 50Ton (5MPa), allowing excess epoxy to be released while maintaining a consistent thickness. The composite was loaded for 12 hours at room temperature before opening the mold and carefully removing the

produced composite material. All nine composites were given the same treatment. They were all made and cured in a room temperature environment.



Figure 3. 6 Fabrication of composite and fabricated sample

3.10 Preparation of Specimens for Testing

The sample used in the present study was made in compliance with the American Society for Testing Materials (ASTM) guidelines. These samples were subjected to tensile, compression, flexural, impact, and water absorption tests. Fabricated composites were cut using a circular band saw machine in accordance with ASTM requirements.

Tensile test specimen: Tensile testing was performed in accordance with ASTM D3039. This standard is 250mm x 25mm x 3mm in size.

Flexural test specimen: Flexural testing is performed in accordance with ASTM D790. This standard is rectangular in shape, measuring 125mm x 13mm x 3mm.

Impact test specimen: The impact testing standard used was ASTM D256. This standard is 64mm x 13mm x 3mm in size.

Compression test specimen: The compression test standard that is used is ASTM D3410. This standard is 80mm x 20mm x 3mm in size.

Water absorption test specimen: The ASTM D570 standard for water absorption testing was used. This standard is 76mm x 25mm x 3mm in size.

3.11 Procedures and Conditions for Experiment Testing

The fabricated hybrid composite materials were tested using five different testing procedures after being cut into standard specimen sizes. Tensile, compression, and flexural testing were performed using a computerized universal material testing machine model ETM-50 with a maximum capacity of 50KN. The Charpy impact tester was used for the impact testing. Each machine produced results that can be estimated and investigated more.

In each of the five experimental tests, at least three specimens have been investigated for each of nine composite compositions. As a consequence, at least 135 specimens were examined to verify consistency and to minimize mistakes as far as feasible. Everything was accomplished at ambient temperature.

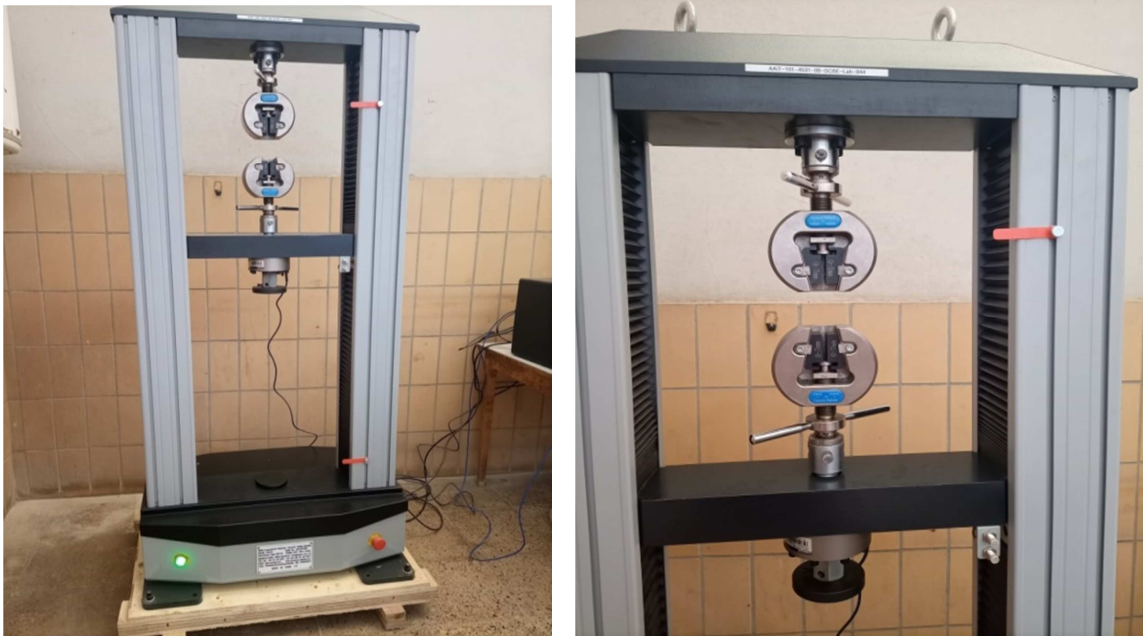

Figure 3. 7 Computerized universal testing machine

Tensile Testing: The tensile test was performed at ambient temperature at a rate of 5mm/min in the lengthwise direction of the composite. The test piece was inserted upright into the examining device's jaws. The top jaw remained in place but the bottom jaw moved. When a rupture develops, the device pauses and shows the findings on a monitor.



Figure 3. 8 Prepared tensile test sample



Figure 3. 9 Tensile testing setups and sample after fracture

Compression Testing: with the help of UTM, the samples were exposed to an axial pressing force till breakage to test their compression strength. Upper and lower compression anvils were used to place samples.



Figure 3. 10 Compression testing setups and samples after fracture

Flexural Testing: In this test, the flexural strength was determined by employing the three-point bending mode. The sample was supported by a two-point support bed with a 125mm spread. The specimen's central span was then loaded using the one-point top jaw. The experiment was conducted out at ambient temperature and at a rate of 5mm/min. Each composite was evaluated with a minimum of three samples.



Figure 3. 11 Flexural testing setups and sample after fracture

Impact Testing: To measure fracture toughness, a sample was secured onto the device's table and struck by a swinging pendulum falling from a 45-degree angle to strike and shatter the sample. All nine composites were tested for impact strength using Charpy impact. The dial gauge connected to the pendulum string was used to quantify the magnitude of energy received by the sample throughout the breaking (its impact strength). It demonstrates the force of the impact.

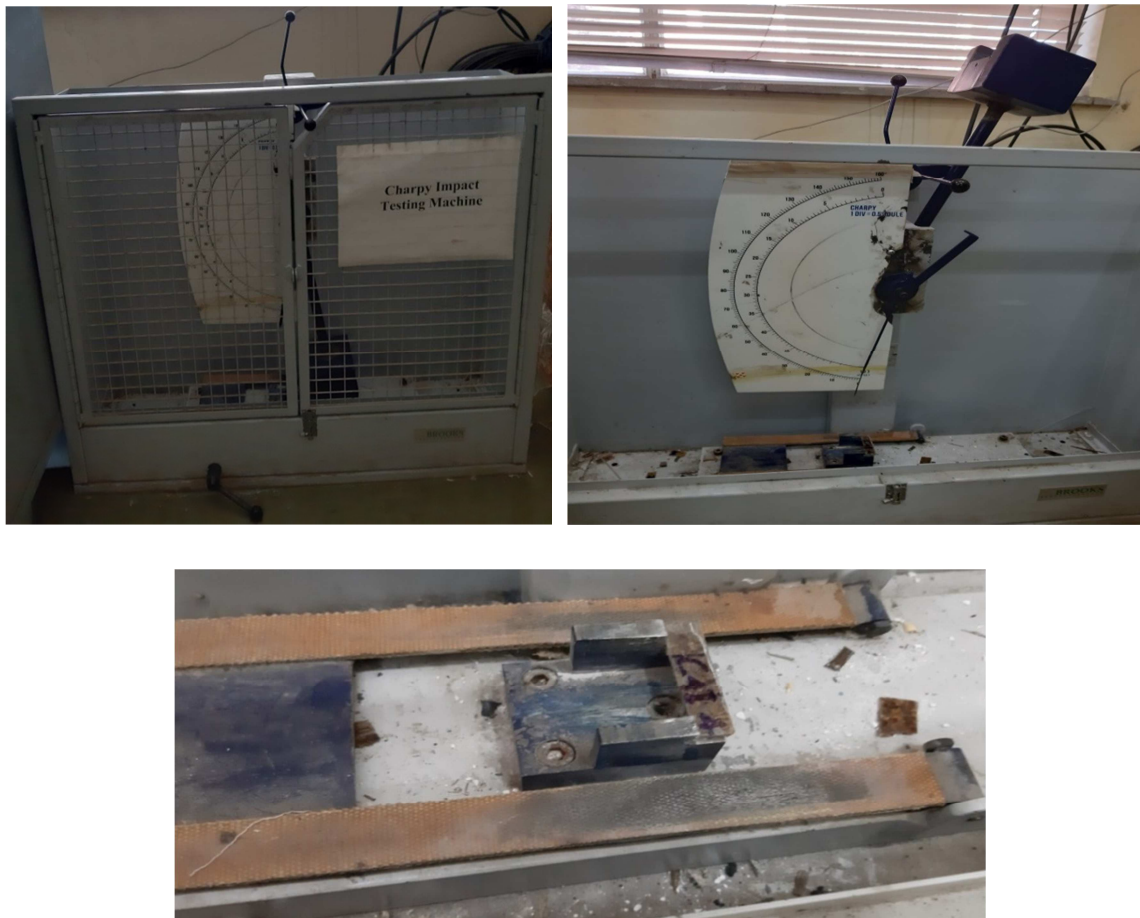

Figure 3. 12 Charpy Impact testing machine setups

Water Absorption Test: For the water absorption test, each sample was submerged in water for one day at ambient temperature. All specimens were measured using a digital weighing device prior to soaking, and the findings of every sample were recorded. Within 24 hours, the samples had been taken out and wiped to eliminate any extra fluid on the exterior. Lastly, the samples were weighed again. Following this, the percent of gain in weight was determined with the approach explained beneath.

$$\text{water absorption \%} = \frac{\text{Final Weight} - \text{Initial Weight}}{\text{Initial Weight}} \times 100 \dots\dots\dots\text{eq.}$$

Where; Final Mass is what it weighs after 24 hours of soaking

The initial mass is what it weighs prior of soaking.



Figure 3. 13 Water absorption specimens submerged in a tank of water

Chapter Four

Results of the experiments, FEM computation, and Discussions

4.1 Experimental Result

As previously stated, nine composite specimens were tested in accordance with ASTM standards. The test findings explain the qualities of the developed enset-coffee husk fibre reinforced Epoxy hybrid composites. All produced composites contain hybrid reinforcement that has been trimmed in to (enset fiber 3-8mm and coffee husk 0.2-1.8mm) lengths. All composites were treated with NaOH and have varying fiber loadings. At least three specimen samples were produced and evaluated for each combination.

Every composite was examined, and the findings are presented below.

4.1.1 Tensile Test Result

Composite One: Is a composite composed of shredded reinforced hybrid fibres, 10% enset, 10% coffee husk, and 80% epoxy. Three samples were evaluated for this composite in compliance with ASTM D3039.

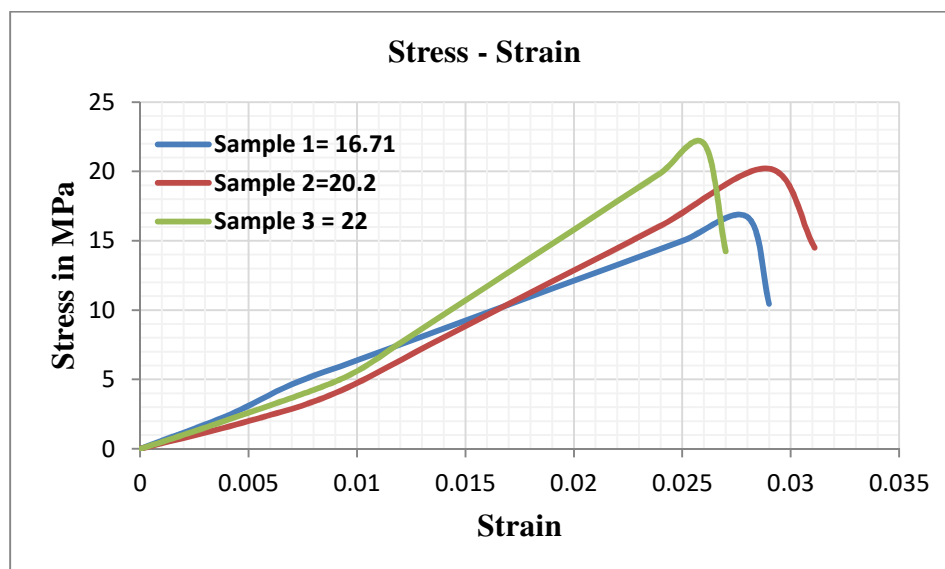

Figure 4. 1 Composite 1 (E10%, CH10%, and E80%) Tensile test Stress-Strain Curve

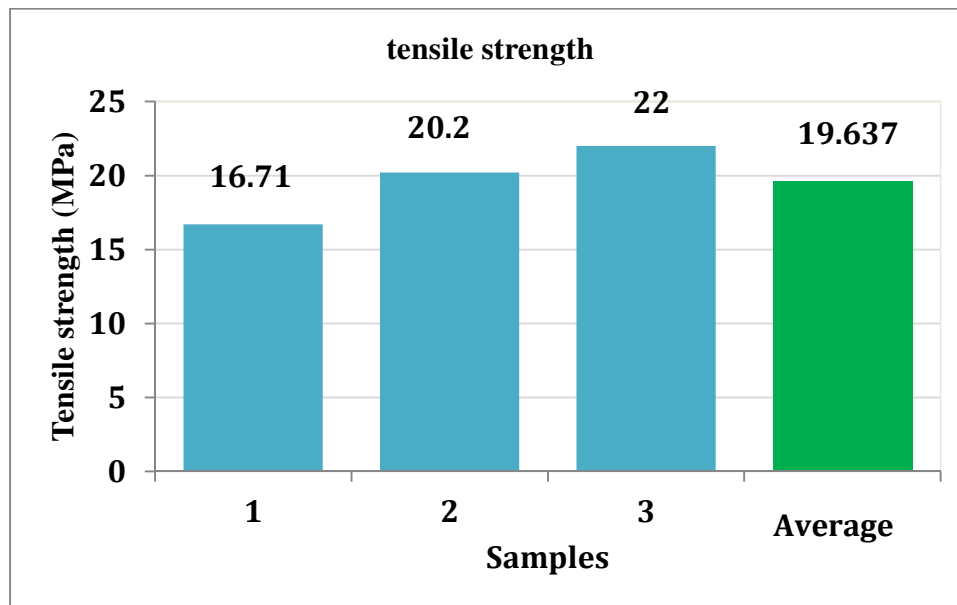

Figure 4. 2 Composite C1 Specimens Tensile Strength and their Mean

Composite Two: Is a composite composed of shredded reinforced hybrid fibres, 5% enset, 15% coffee husk, and 80% epoxy. Three samples were evaluated for this composite in compliance with ASTM D3039.

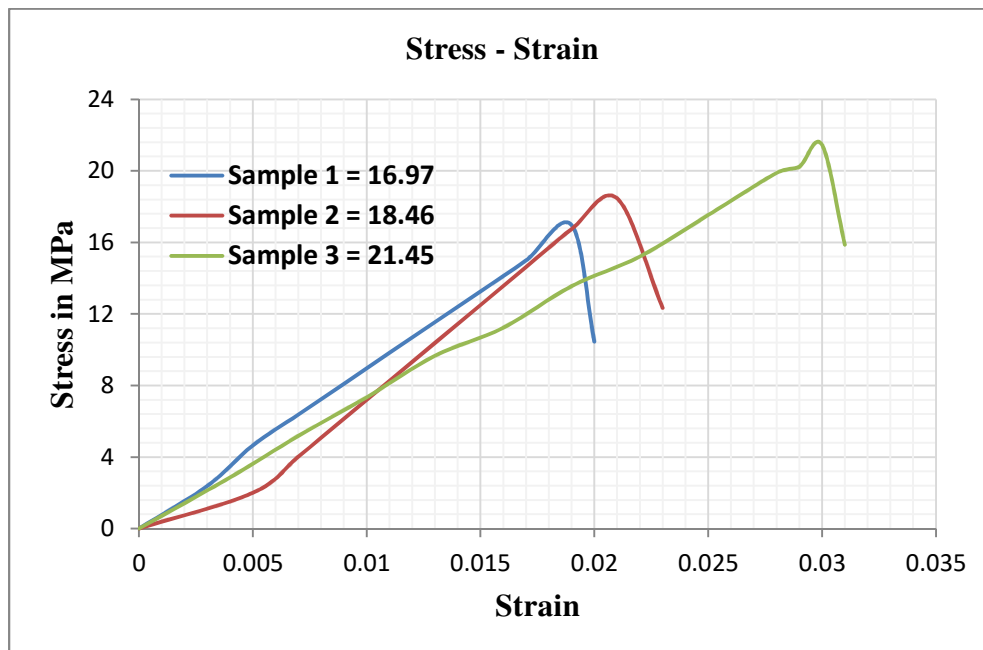

Figure 4. 3 Composite 2 (E5%, CH15%, and E80%) Tensile test Stress-Strain Curve

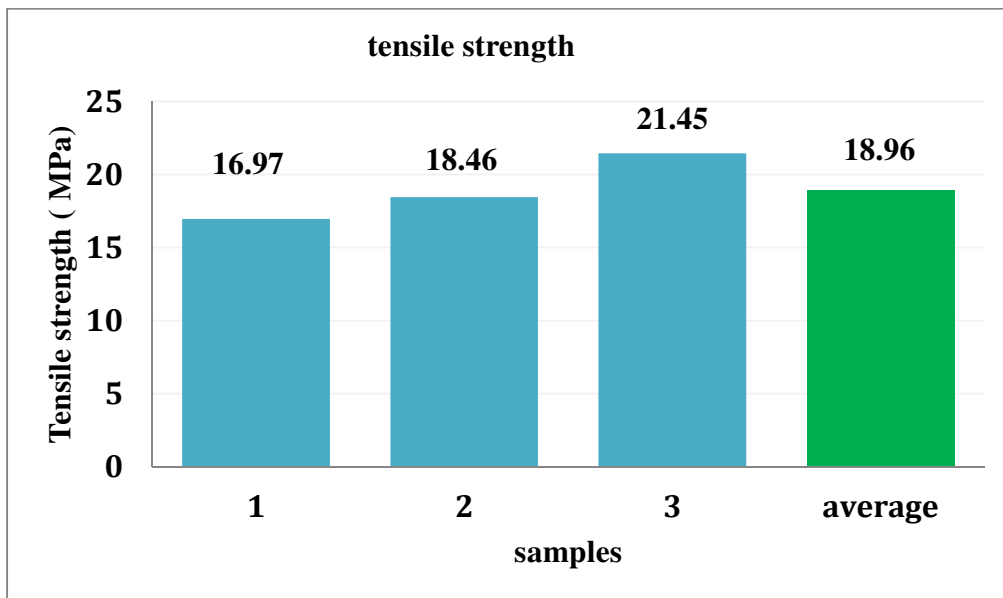

Figure 4. 4 Composite C2 Specimens Tensile Strength and their Mean

Composite Three: Is a composite composed of shredded reinforced hybrid fibres, 15% enset, 5% coffee husk, and 80% epoxy. Three samples were evaluated for this composite in compliance with ASTM D3039.

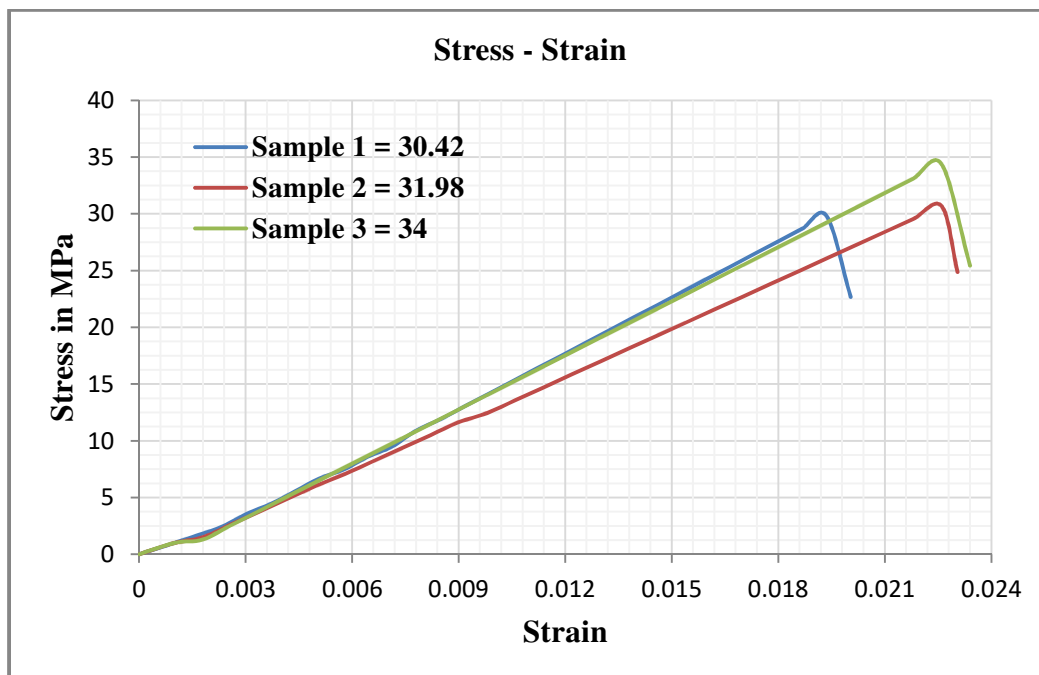

Figure 4. 5 Composite 3 (E15%, CH5%, and E80%) Tensile test Stress-Strain Curve

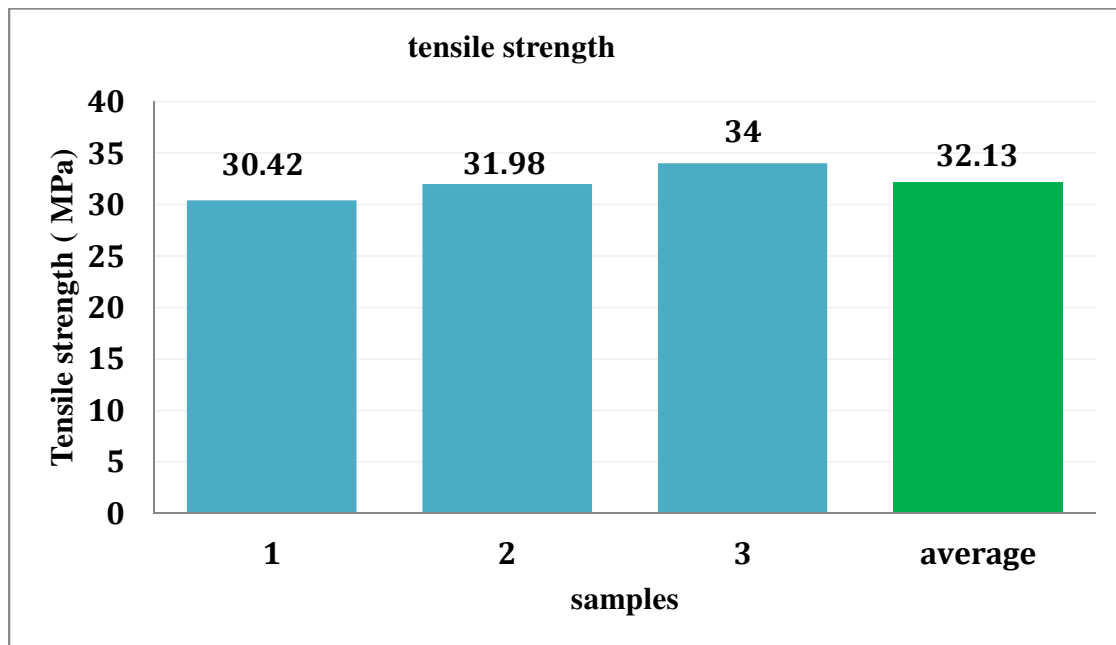

Figure 4. 6 Composite C3 Specimens Tensile Strength and their Mean

Composite Four: Is a composite composed of shredded reinforced hybrid fibres, 15% enset, 15% coffee husk, and 70% epoxy. Three samples were evaluated for this composite in compliance with ASTM D3039.

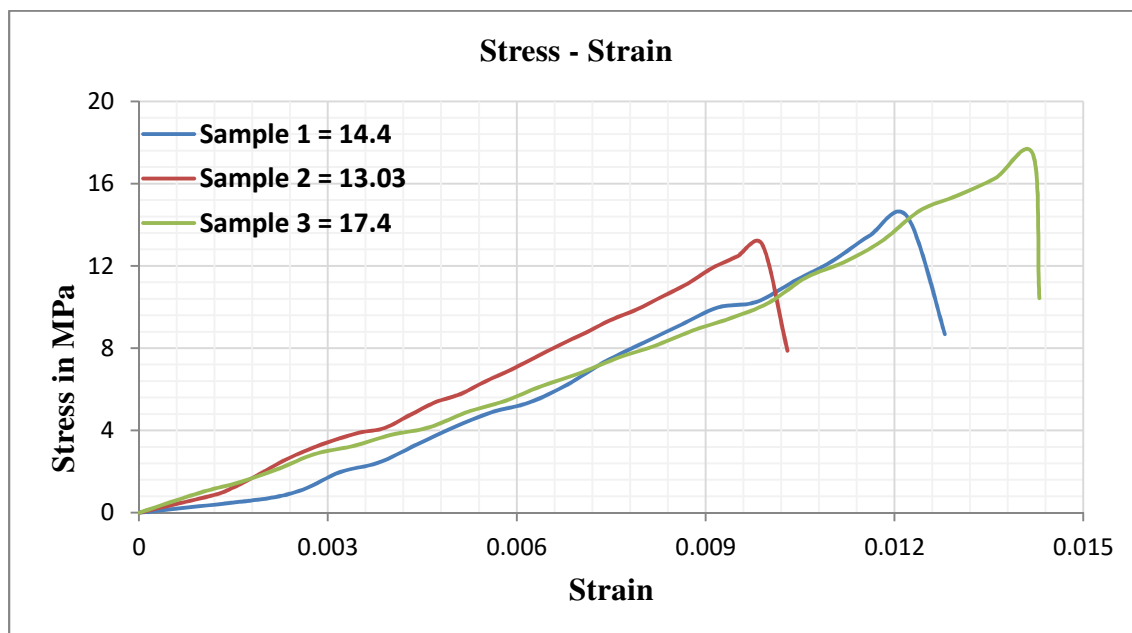

Figure 4. 7 Composite 4 (E15%, CH15%, and E70%) Tensile test Stress-Strain Curve

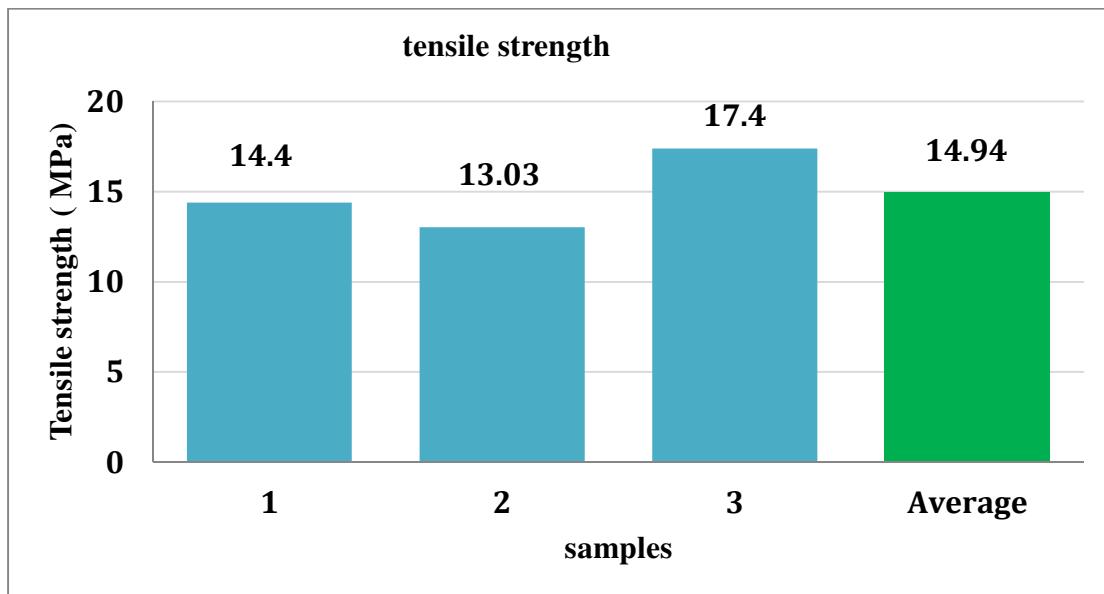

Figure 4. 8 Composite C4 Specimens Tensile Strength and their Mean

Composite Five: Is a composite composed of shredded reinforced hybrid fibres, 20% enset, 10% coffee husk, and 70% epoxy. Three samples were evaluated for this composite in compliance with ASTM D3039.

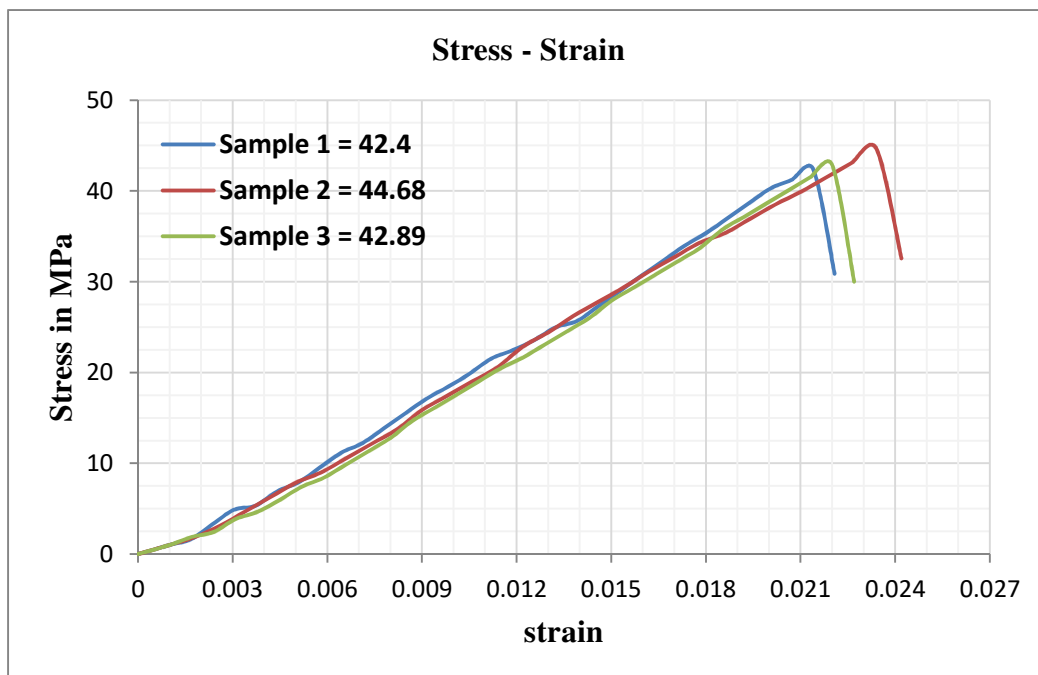

Figure 4. 9 Composite 5 (E20%, CH10%, and E70%) Tensile test Stress-Strain Curve

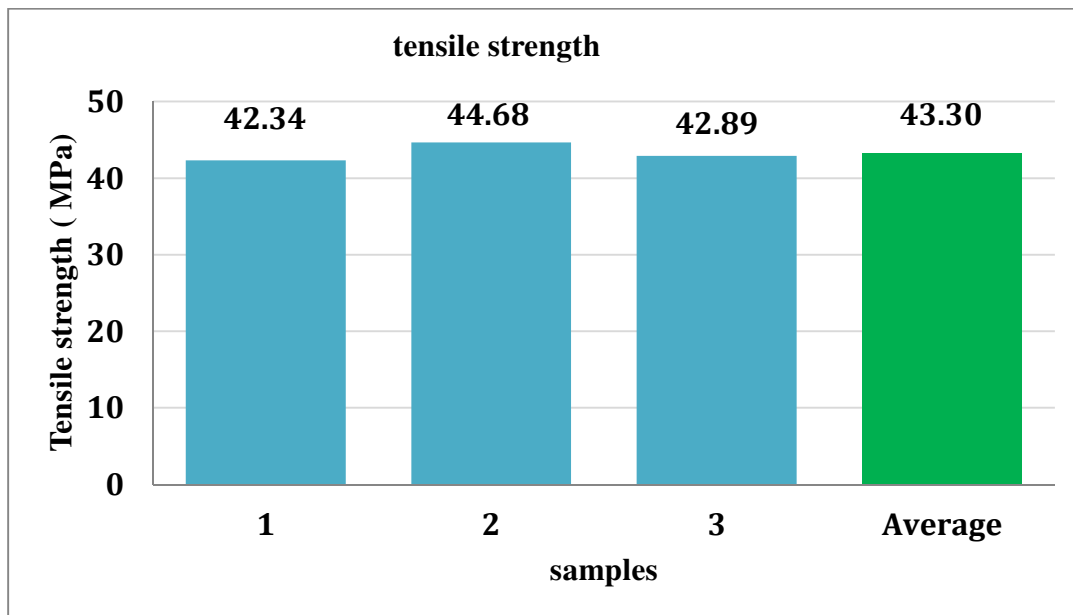

Figure 4. 10 Composite C5 Specimens Tensile Strength and their Mean

Composite Six: Is a composite composed of shredded reinforced hybrid fibres, 10% enset, 20% coffee husk, and 70% epoxy. Three samples were evaluated for this composite in compliance with ASTM D3039.

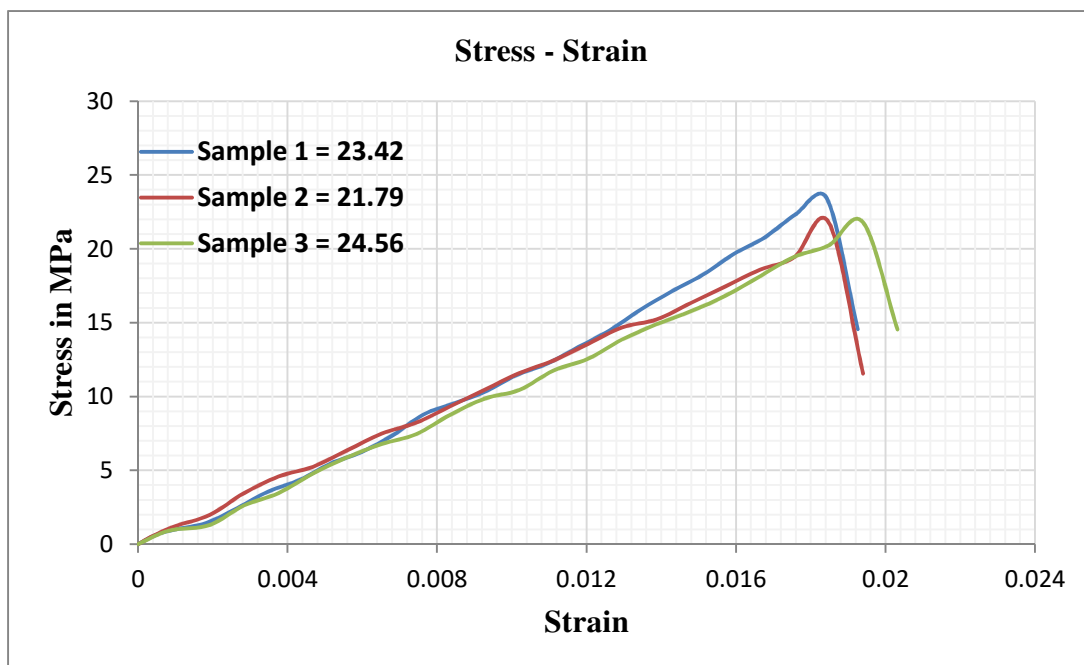

Figure 4. 11 Composite 6 (E10%, CH20%, and E70%) Tensile test Stress-Strain Curve

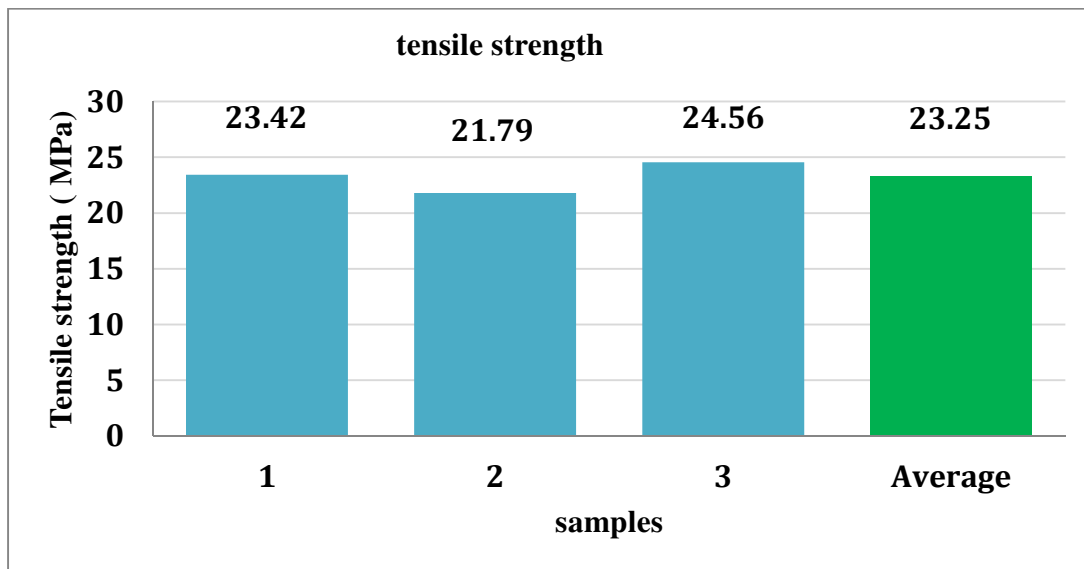

Figure 4. 12 Composite C6 Specimens Tensile Strength and their Mean

Composite Seven: Is a composite composed of shredded reinforced hybrid fibres, 20% enset, 20% coffee husk, and 60% epoxy. Three samples were evaluated for this composite in compliance with ASTM D3039.

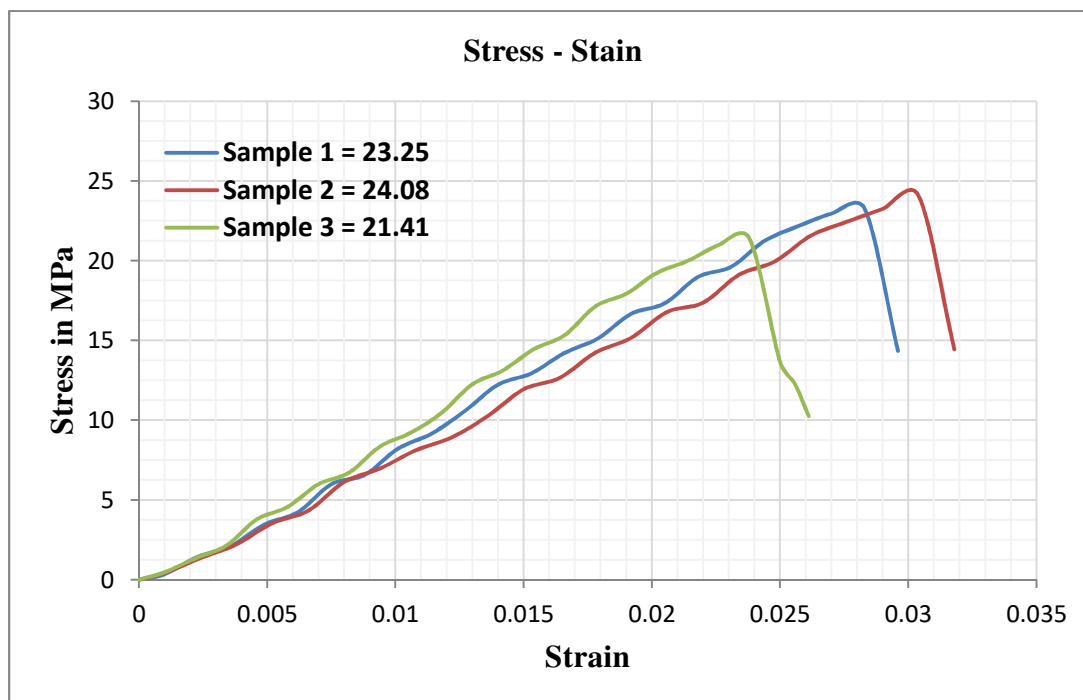

Figure 4. 13 Composite 7 (E20%, CH20%, and E60%) Tensile test Stress-Strain Curve

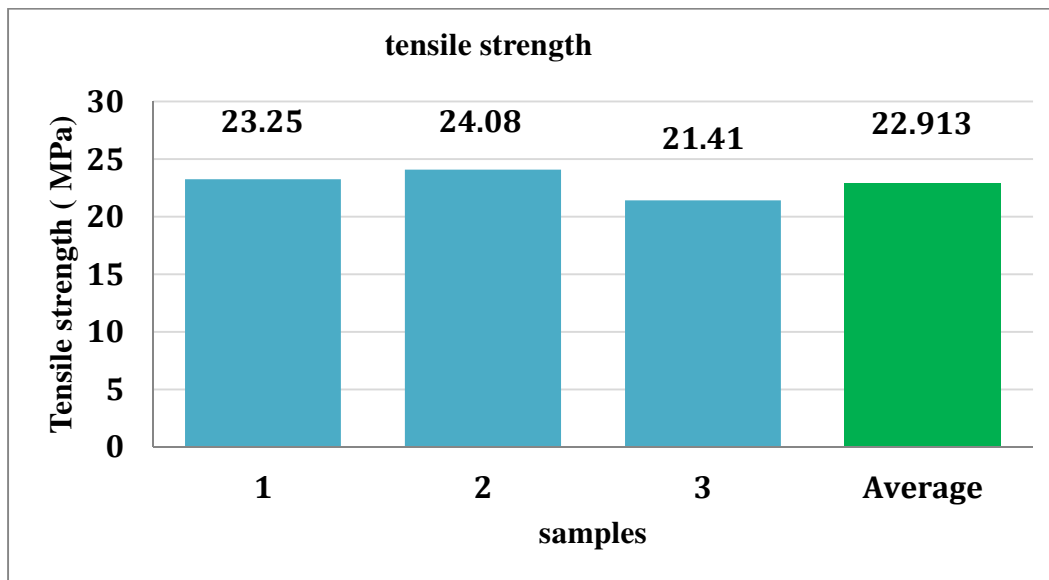

Figure 4. 14 Composite C7 Specimens Tensile Strength and their Mean

Composite Eight: Is a composite composed of shredded reinforced hybrid fibres, 30% enset, 10% coffee husk, and 60% epoxy. Three samples were evaluated for this composite in compliance with ASTM D3039.

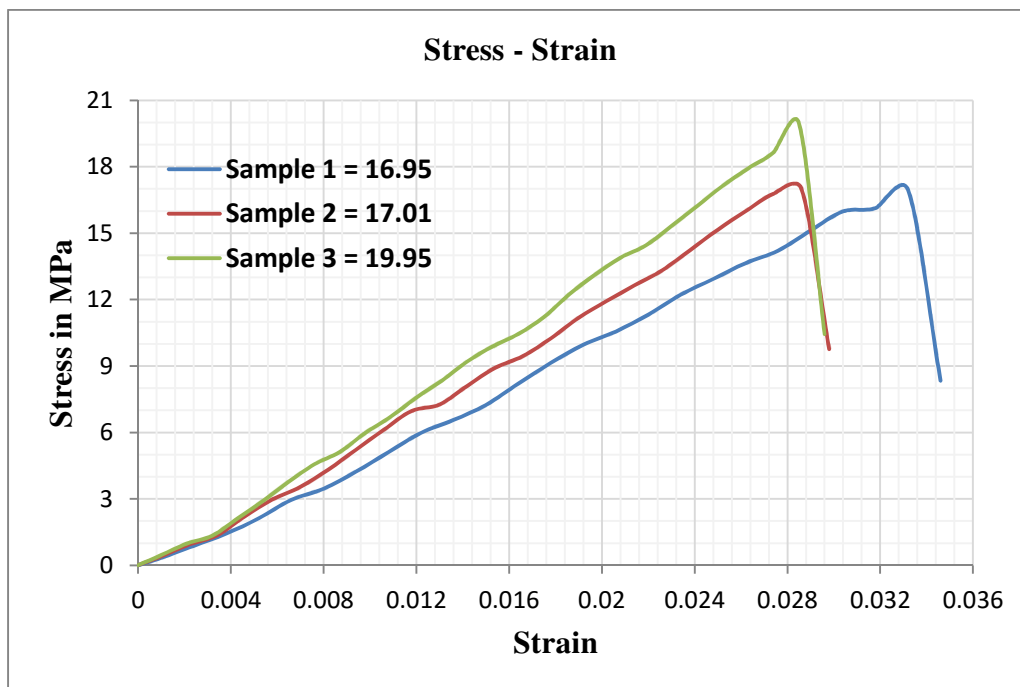

Figure 4. 15 Composite 8 (E30%, CH10%, and E60%) Tensile test Stress-Strain Curve

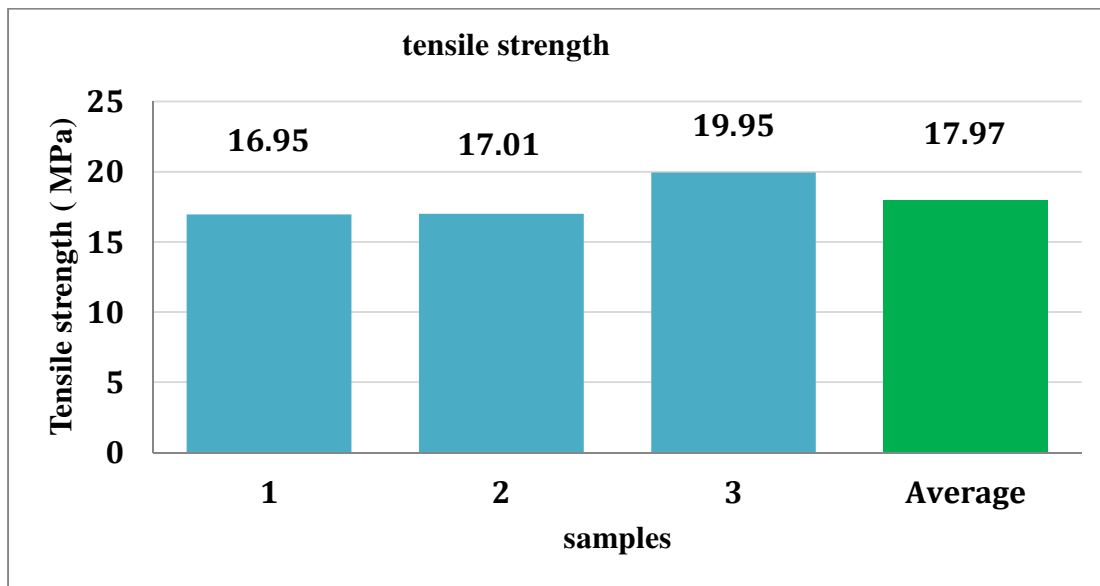

Figure 4. 16 Composite C8 Specimens Tensile Strength and their Mean

Composite Nine: Is a composite composed of shredded reinforced hybrid fibres, 10% enset, 30% coffee husk, and 60% epoxy. Three samples were evaluated for this composite in compliance with ASTM D3039.

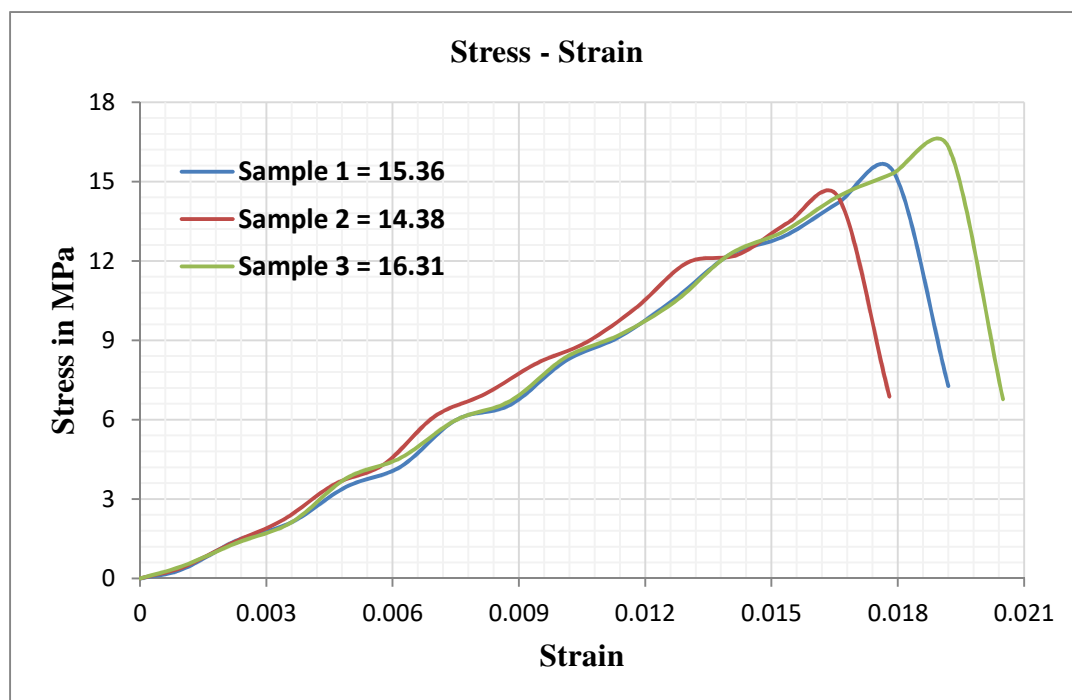

Figure 4. 17 Composite 9 (E10%, CH30%, and E60%) Tensile test Stress-Strain Curve

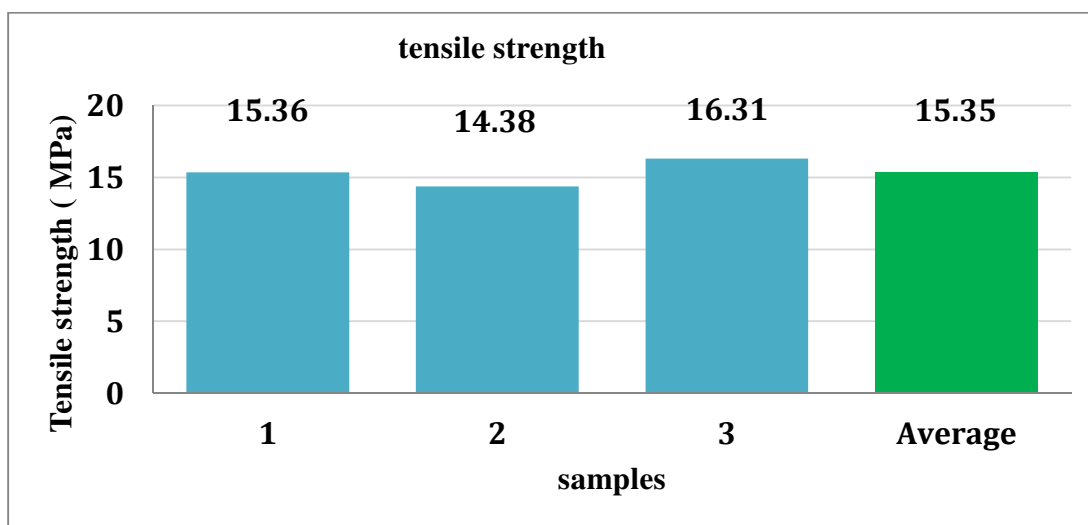

Figure 4. 18 Composite C9 Specimens Tensile Strength and their Mean

Figure 4.19 depicts the entire tensile strength attained for the composites.

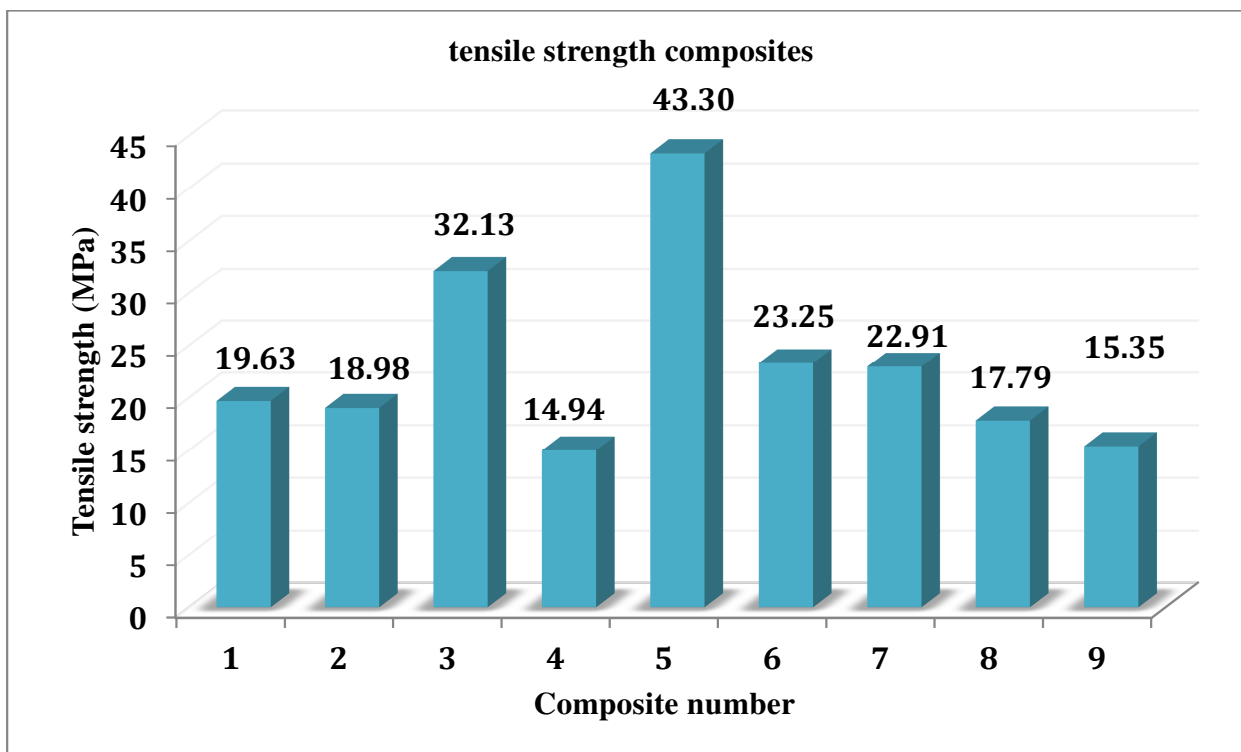

Figure 4. 19 Overall tensile strength of composites Thus, composite sample C5 has a maximum tensile strength of 43.3 MPa, while sample C4 has a maximum tensile strength of 14.94 MPa.

Figure 4.20 The modulus of elasticity test findings for all compositions are summarized.

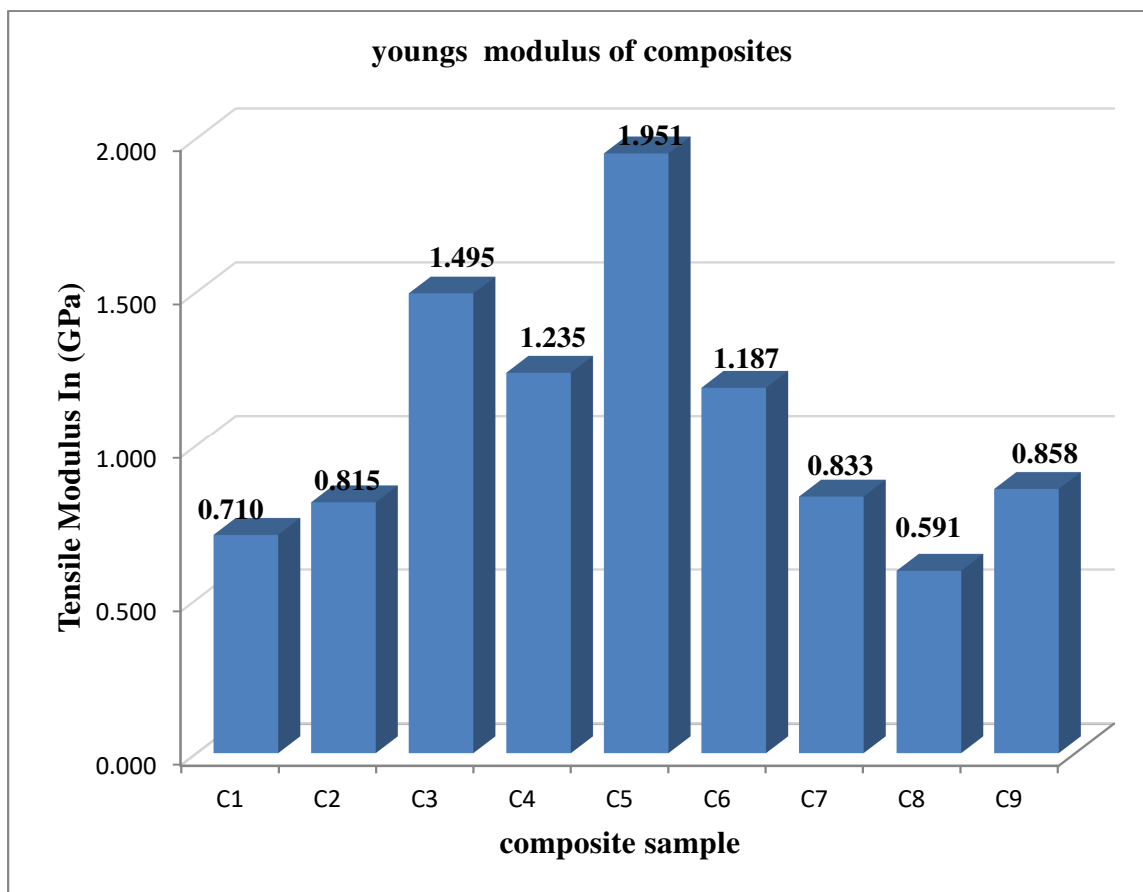

Figure 4. 20 Tensile modulus of all composites samples. Composite sample C5 has the highest tensile modulus of 1.951GPa, while sample C8 has the lowest at 0.591 GPa.

4.1.2 Compression Test Result

During the compression test, at least twenty-seven specimens were examined. ASTM requirements were followed in the preparation of the specimens. Each composite category evaluated in this dissertation was characterised using the average findings from the tested specimens. The maximum values and averages for every composite specimen are displayed in the bar plot below.

Composite One: Is a hybrid fibre composite made up of shredded reinforced hybrid fibres (10% Enset, 10% Coffee Husk, and 80% Epoxy). Three samples were evaluated for this composite in compliance with ASTM D3410.

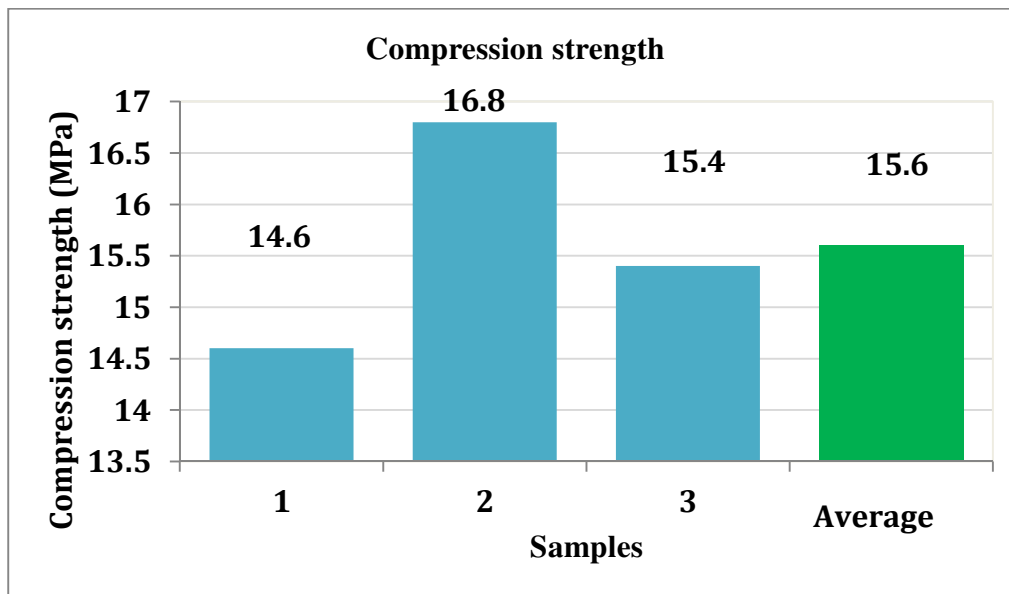

Figure 4. 21 Composite C1 specimens Compression Strength and their Mean

Composite Two: Is a hybrid fibre composite made up of shredded reinforced hybrid fibres of (5% Enset 15% Coffee husk and 80% Epoxy). Three samples were evaluated for this composite in compliance with ASTM D3410.

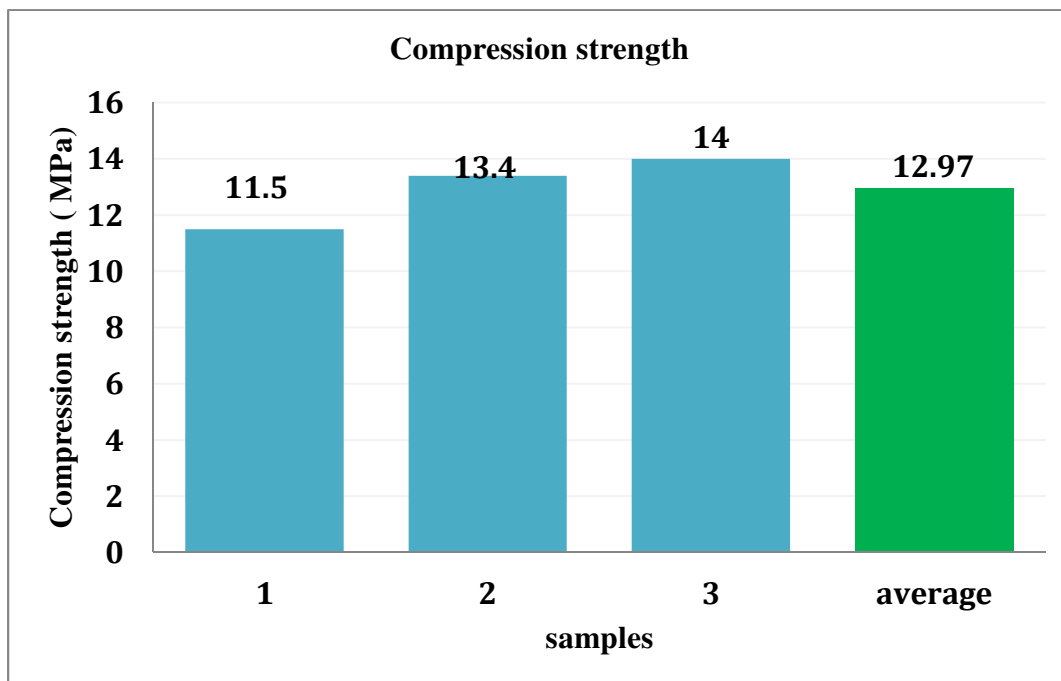

Figure 4. 22 Composite C2 specimens Compression Strength and their Mean

Composite Three: Is a hybrid fibre composite made up of shredded reinforced hybrid fibres of (15% Enset 5% Coffee husk and 80% Epoxy). Three samples were evaluated for this composite in compliance with ASTM D3410.

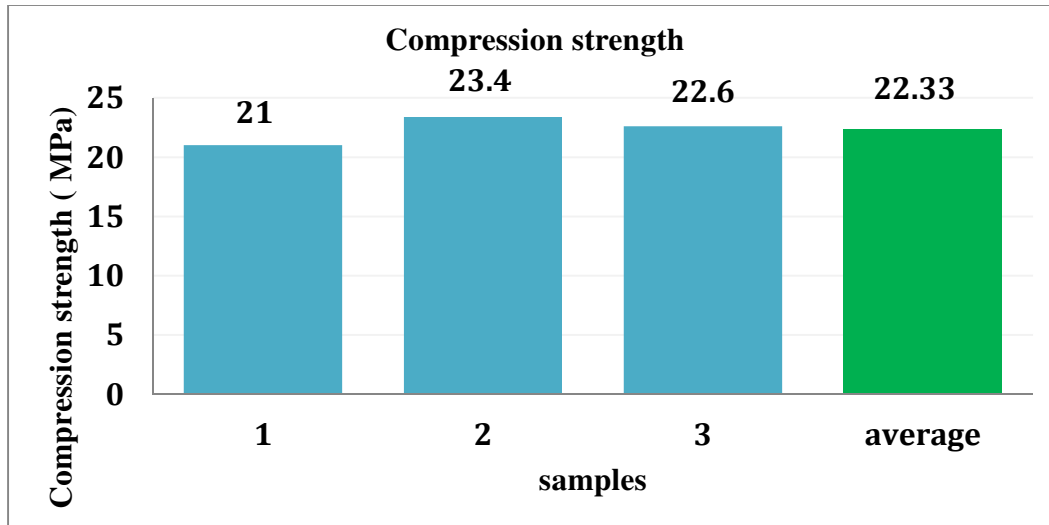

Figure 4. 23 Composite C3 specimens Compression Strength and their Mean

Composite Four: Is a hybrid fibre composite made up of shredded reinforced hybrid fibres of (15% Enset 15% Coffee husk and 70% Epoxy). Three samples were evaluated for this composite in compliance with ASTM D3410.

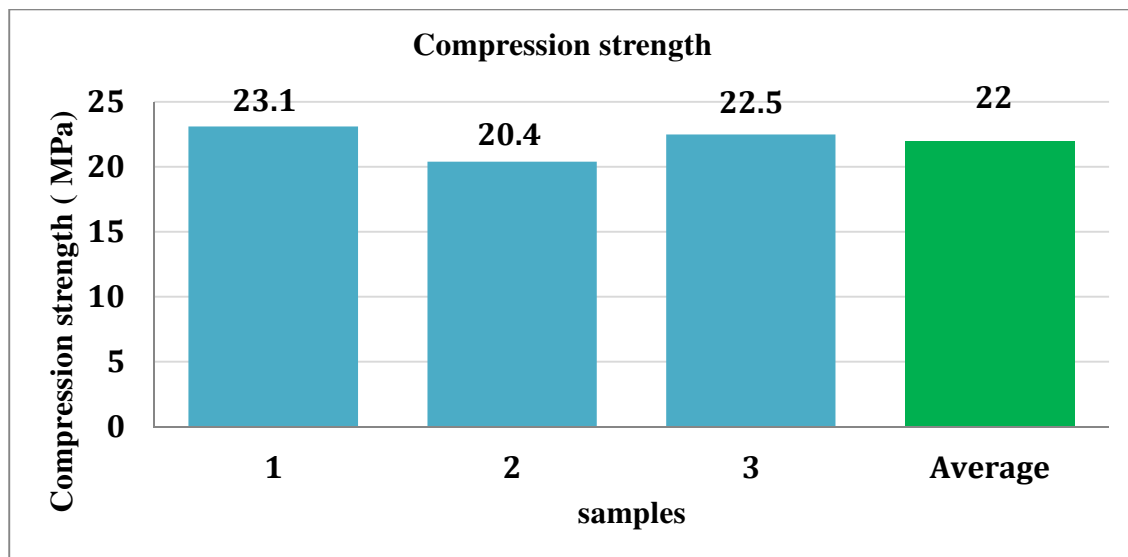

Figure 4. 24 Composite C4 specimens Compression Strength and their Mean

Composite Five: Is a hybrid fibre composite made up of shredded reinforced hybrid fibres of (20% Enset 10% Coffee husk and 70% Epoxy). Three samples were evaluated for this composite in compliance with ASTM D3410.

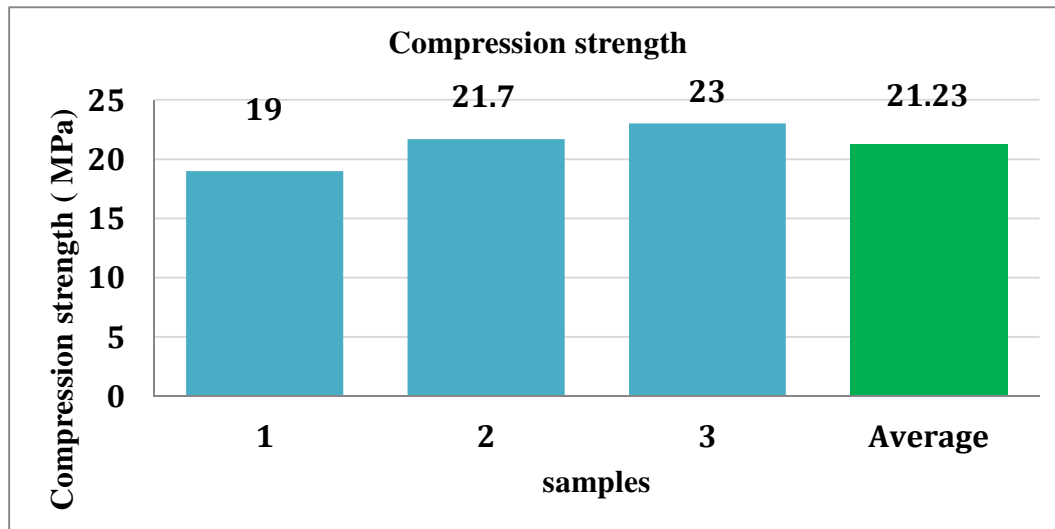

Figure 4. 25 Composite C5 specimens Compression Strength and their Mean

Composite Six: Is a hybrid fibre composite made up of shredded reinforced hybrid fibres of (10% Enset 20% Coffee husk and 70% Epoxy). Three samples were evaluated for this composite in compliance with ASTM D3410.

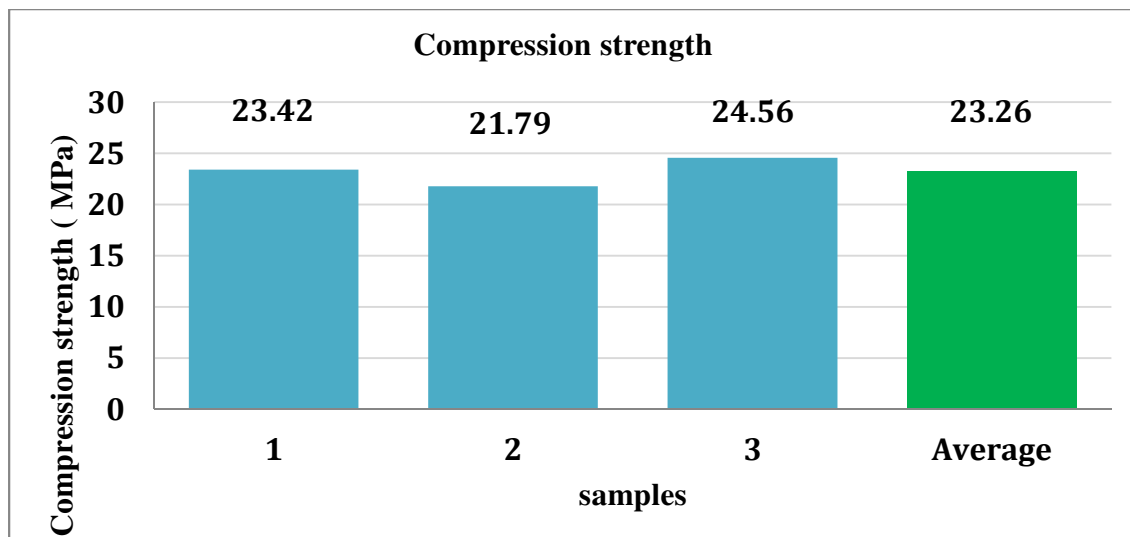

Figure 4. 26 Composite C6 specimens Compression Strength and their Mean

Composite Seven: Is a hybrid fibre composite made up of shredded reinforced hybrid fibres of (20% Enset 20% Coffee husk and 60% Epoxy). Three samples were evaluated for this composite in compliance with o ASTM D3410.

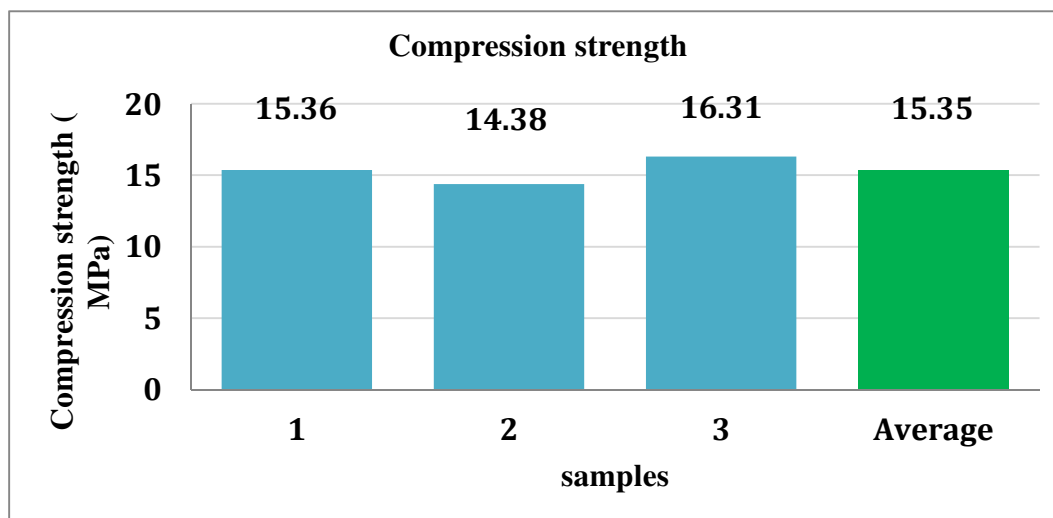

Figure 4. 27 Composite C7 specimens Compression Strength and their Mean

Composite Eight: Is a hybrid fibre composite made up of shredded reinforced hybrid fibres of (30% Enset 10% Coffee husk and 60% Epoxy). Three samples were evaluated for this composite in compliance with o ASTM D3410.

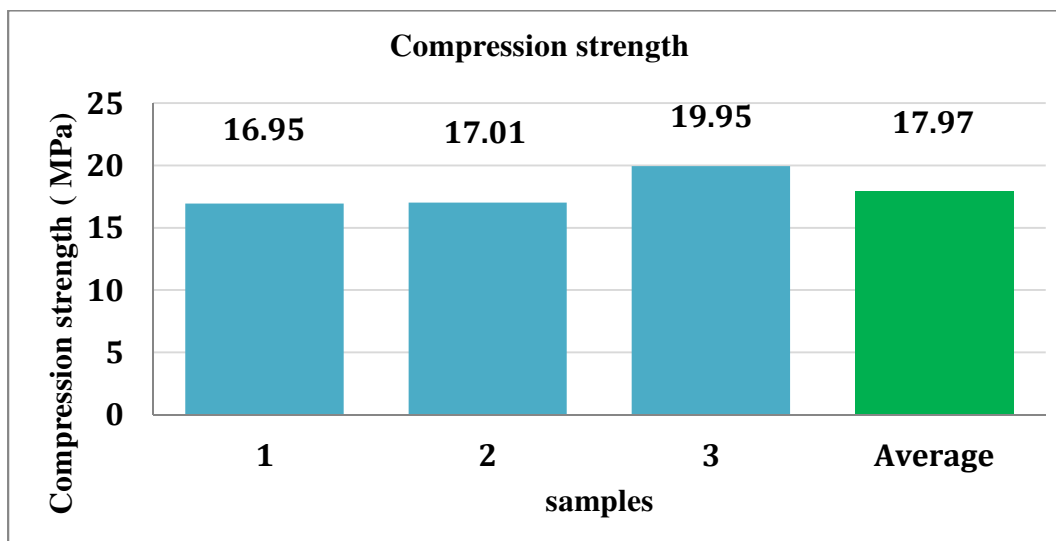

Figure 4. 28 Composite C8 specimens Compression Strength and their Mean

Composite Nine: Is a hybrid fibre composite made up of shredded reinforced hybrid fibres of (10% Enset 30% Coffee husk and 60% Epoxy). Three samples were evaluated for this composite in compliance with ASTM D3410.

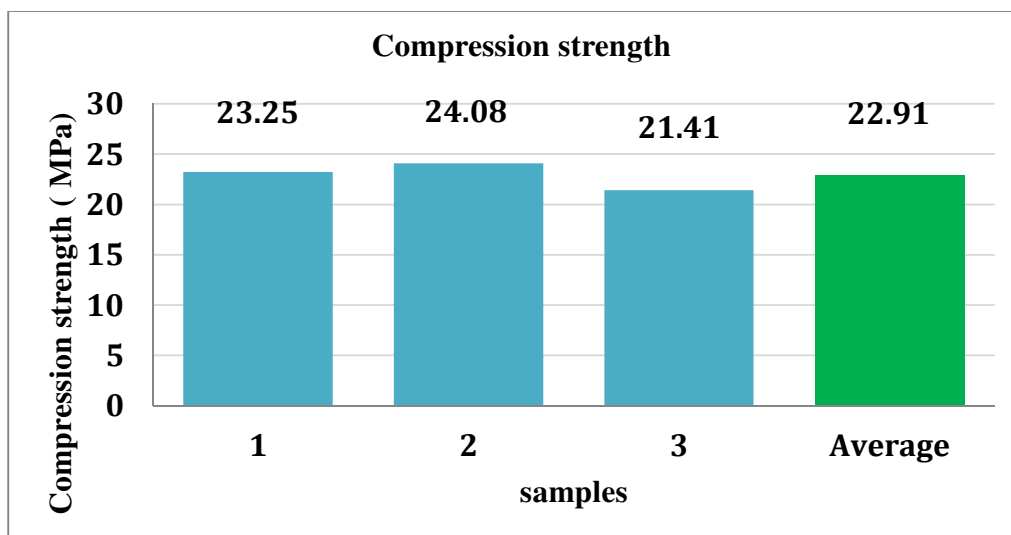

Figure 4. 29 Composite C9 specimens Compression Strength and their Mean

Figure 4.30 depicts the overall compressive strength of the composites.

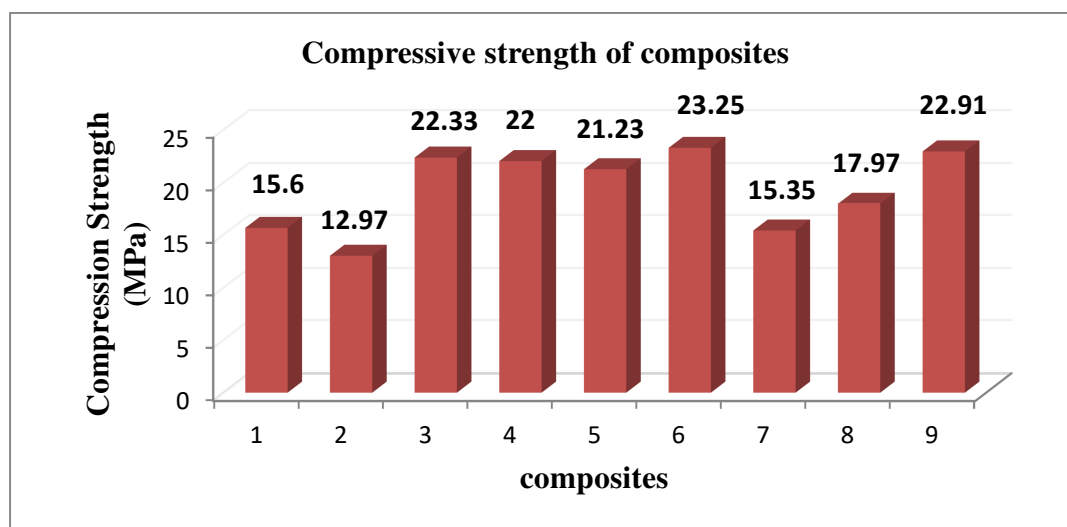

Figure 4. 30 Compressive strength of all composites Enset/coffee husk Epoxy. Composite sample C6 has the highest compressive strength of 23.25 MPa, while sample C2 has the lowest compressive strength of 12.92 MPa.

4.1.3 Flexural Test Result

The flexural test result was obtained via the three-point bending test. The findings of three samples were collected.

Composite One: Is a hybrid fibre composite made up of shredded reinforced hybrid fibres with 10% Enset, 10% Coffee Husk, and 80% Epoxy ASTM D790.

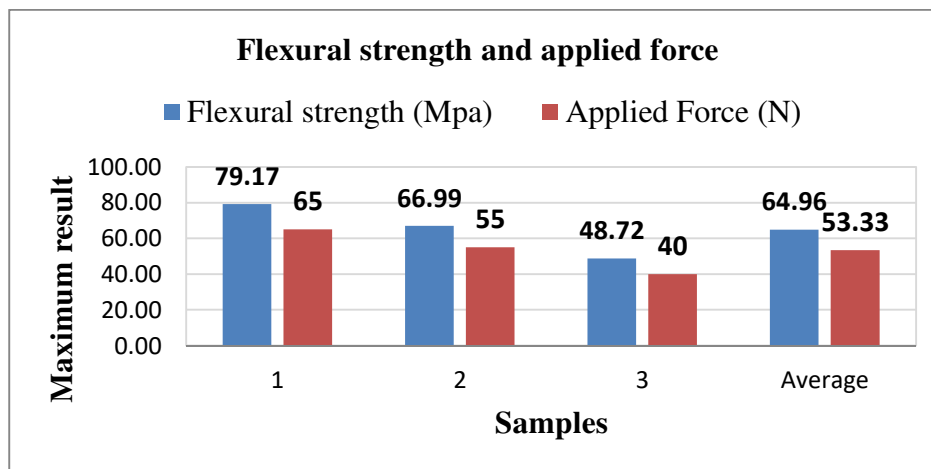

Figure 4. 31 Composite C1 specimens flexural strength, applied force and their mean

Composite Two: Is a hybrid fibre composite made up of shredded reinforced hybrid fibres with of 5% Enset 15% Coffee husk and 80% Epoxy. ASTM D790

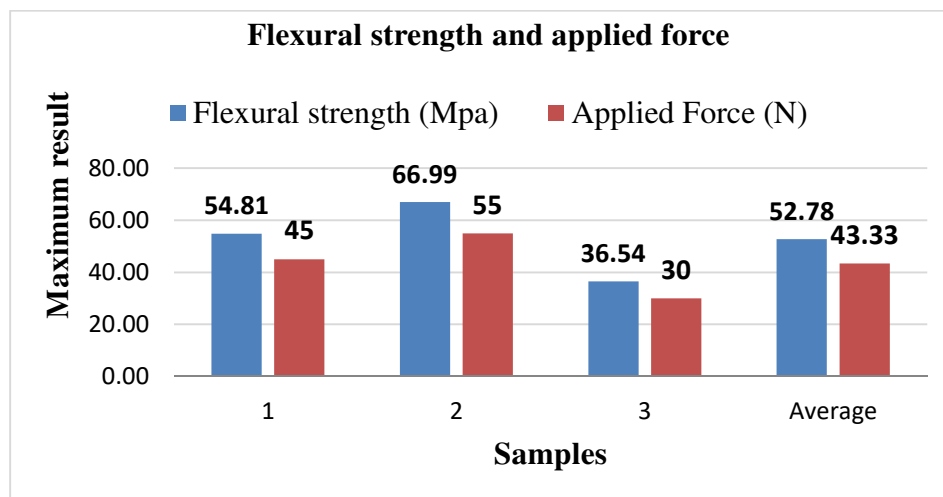

Figure 4. 32 Composite C2 specimens flexural strength, applied force and their mean

Composite Three: Is a hybrid fibre composite made up of shredded reinforced hybrid fibres with 15% Enset 5% Coffee husk and 80% Epoxy. ASTM D790

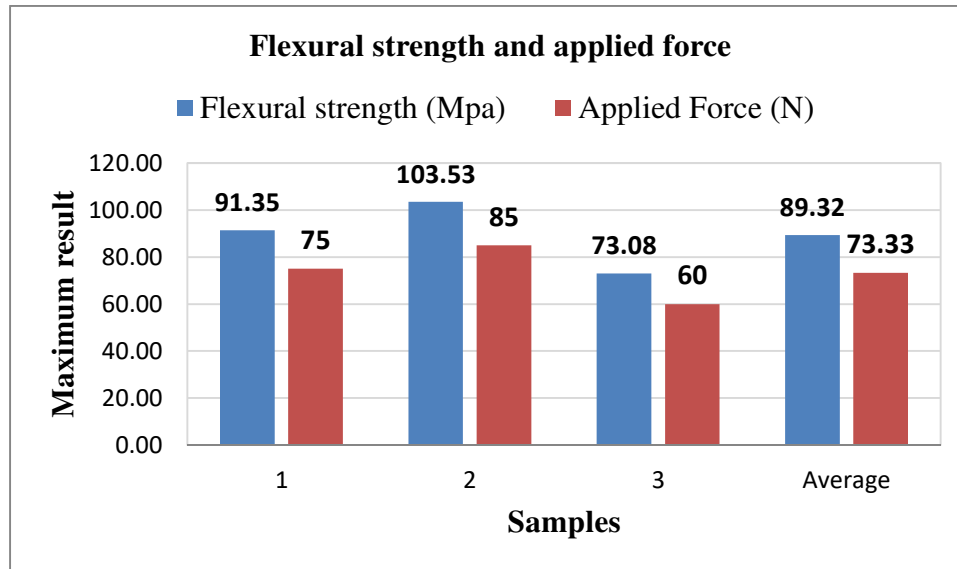

Figure 4. 33 Composite C3 specimens flexural strength, applied force and their mean

Composite Four: Is a hybrid fibre composite made up of shredded reinforced hybrid fibres with 15% Enset 15% Coffee husk and 70% Epoxy. ASTM D790

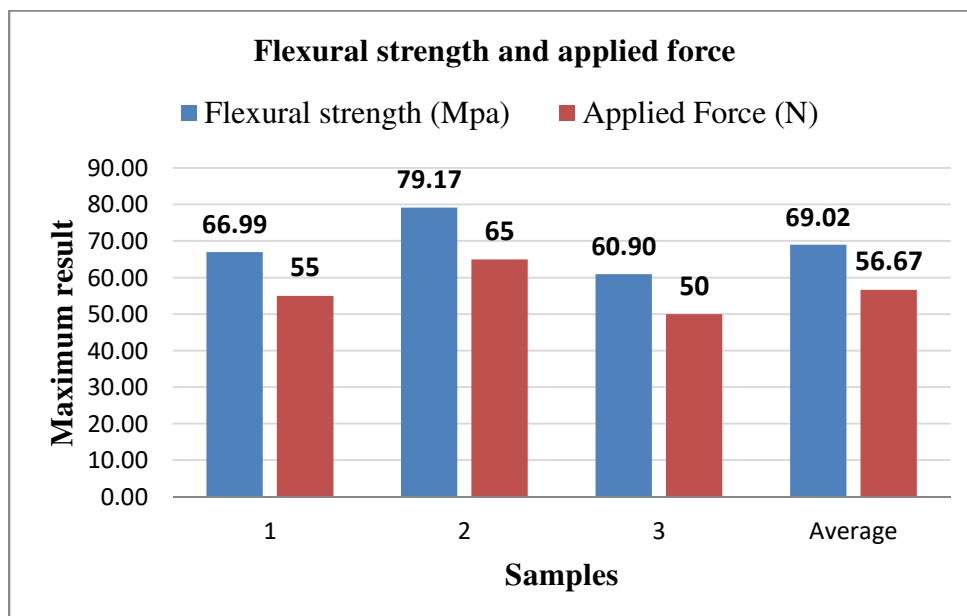

Figure 4. 34 Composite C4 specimens flexural strength, applied force and their mean

Composite Five: Is a hybrid fibre composite made up of shredded reinforced hybrid fibres with 20% Enset 10% Coffee husk and 70% Epoxy. ASTM D790

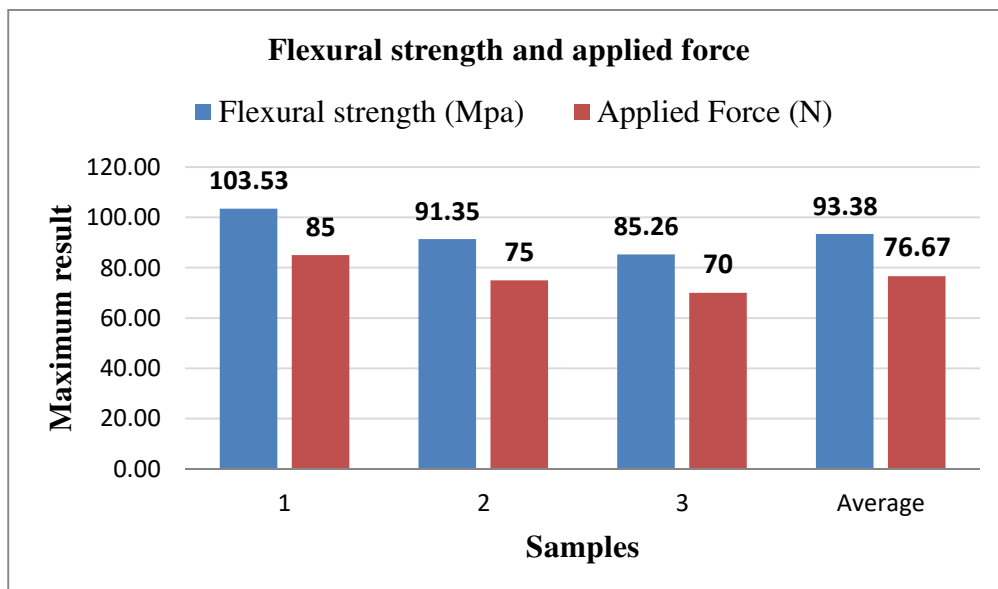

Figure 4. 35 Composite C5 specimens flexural strength, applied force and their mean

Composite Six: Is a hybrid fibre composite made up of shredded reinforced hybrid fibres with 10% Enset 20% Coffee husk and 70% Epoxy. ASTM D790

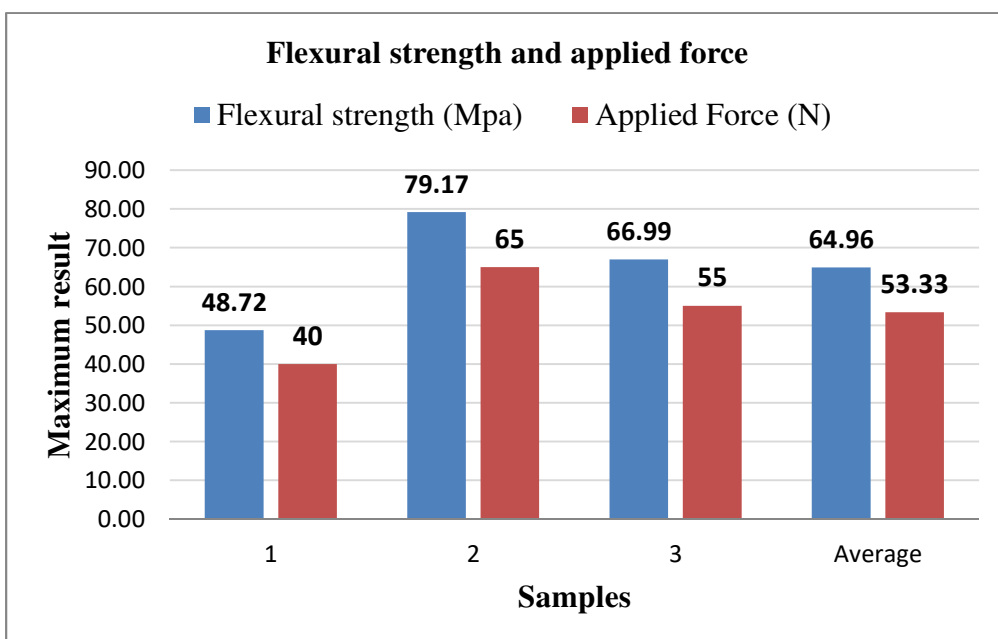

Figure 4. 36 Composite C6 specimens flexural strength, applied force and their mean

Composite Seven: Is a hybrid fibre composite made up of shredded reinforced hybrid fibres with 20% Enset 20% Coffee husk and 60% Epoxy. ASTM D790. The result of the test is as follows.

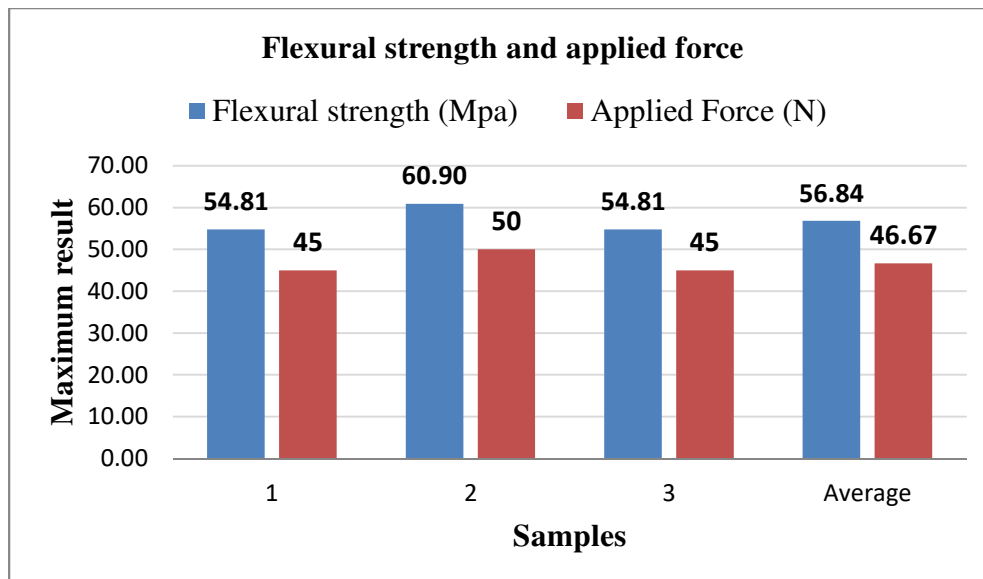

Figure 4. 37 Composite C7 specimens flexural strength, applied force and their mean

Composite Eight: Is a hybrid fibre composite made up of shredded reinforced hybrid fibres with 30% Enset 10% Coffee husk and 60% Epoxy. ASTM D790.

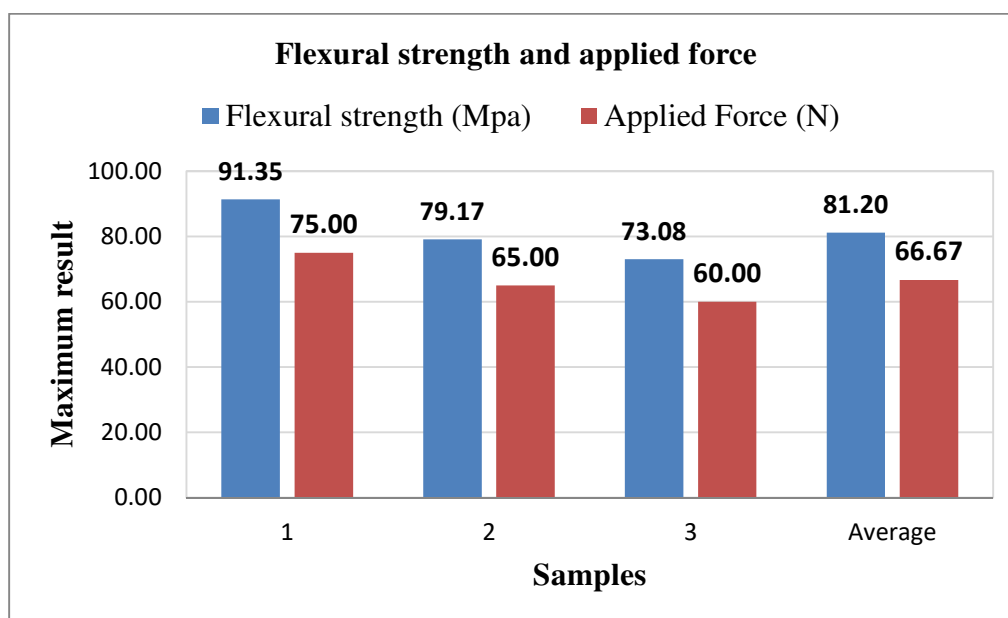

Figure 4. 38 Composite C8 specimens flexural strength, applied force and their mean

Composite Nine: Is a hybrid fibre composite made up of shredded reinforced hybrid fibres with 10% Enset 30% Coffee husk and 60% Epoxy. ASTM D790

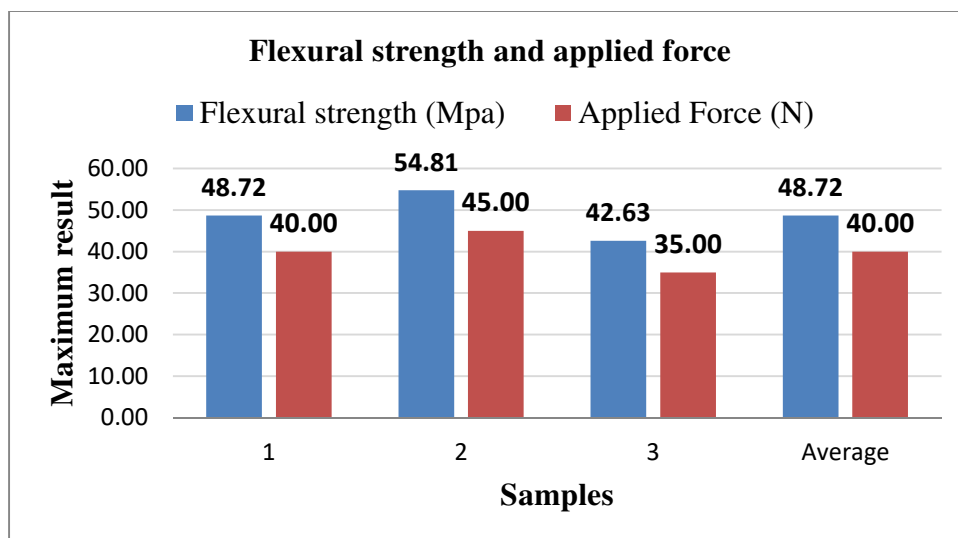

Figure 4.39 Composite C9 specimens flexural strength, applied force and their mean

Figures 4.40 and 4.41 show the overall flexural strength and maximum test forces obtained from experimental test for Enset-coffee husk epoxy composite.

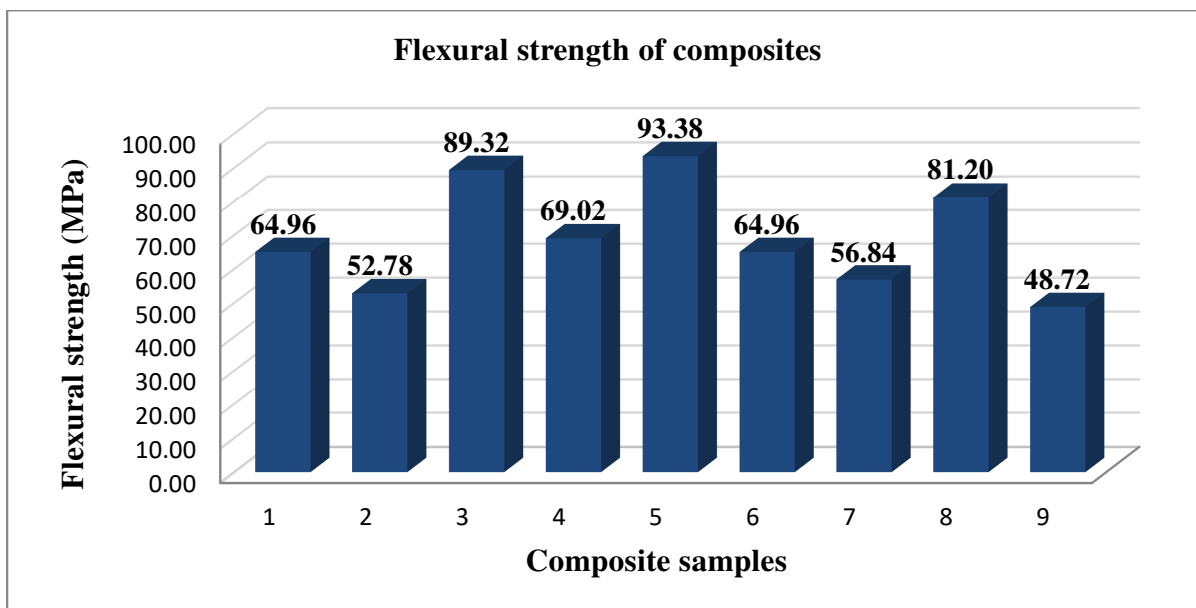

Figure 4.40; Flexural Strength for all Enset/Coffee Husk Epoxy Composites samples. Composite sample C5 has the highest Flexural strength of 93.38 MPa, while sample C9 has the lowest Flexural strength of 48.72 MPa.

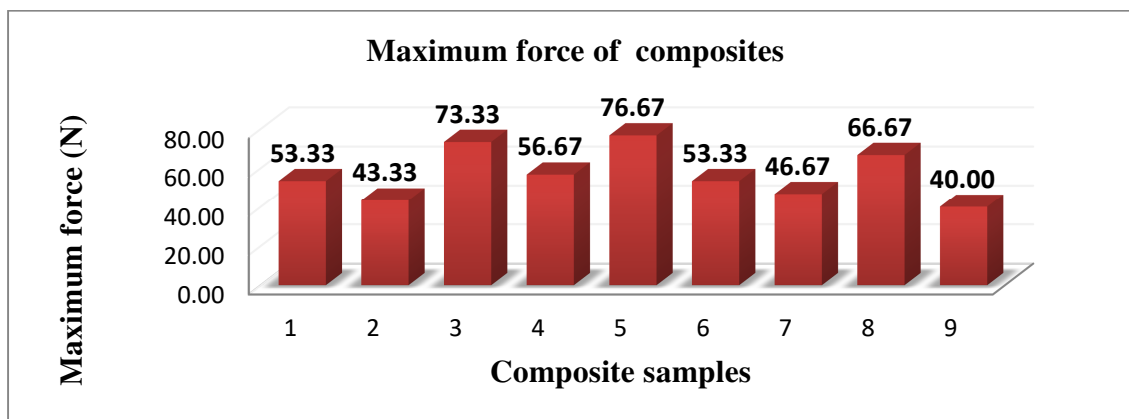

Figure 4.41 Optimum operating pressure for all Enset/Coffee Husk Epoxy Composites. Composite sample C5 has a maximum testing force of 76.67 N and sample C9 has the lowest testing force of 40 N.

4.1.4 Impact Test Result

The table below shows the results of all nine composite specimens. The results of all composite specimen samples that were tested were described in this work.

Table 4. 1 Impact Energy result

No.	Composite Composition	Sample no.	Energy(J)
1	<i>Enset 10%, coffee husk 10% and epoxy 80%</i>	1	3.5
		2	3.0
		3	3.0
		Average	3.2
2	<i>Enset 5%, coffee husk 15% and epoxy 80%</i>	1	4.0
		2	3.5
		3	3.5
		Average	3.3
3	<i>Enset 15%, coffee husk 5% and epoxy 80%</i>	1	3.0
		2	2.5

		3	2.5
		Average	2.7
4	<i>Enset 15%, coffee husk 15% and epoxy 70%</i>	1	2.5
		2	3.5
		3	3.0
		Average	3.0
5	<i>Enset 20%, coffee husk 10% and epoxy 70%</i>	1	4
		2	3.5
		3	3.0
		Average	3.5
6	<i>Enset 10%, coffee husk 20% and epoxy 70%</i>	1	3.0
		2	4.0
		3	3.0
		Average	3.3
7	<i>Enset 20%, coffee husk 20% and epoxy 60%</i>	1	3.0
		2	2.5
		3	3.5
		Average	3.0
8	<i>Enset 30%, coffee husk 10% and epoxy 60%</i>	1	3.0
		2	3.0
		3	3.0
		Average	3.0
9	<i>Enset 10%, coffee husk 30% and epoxy 60%</i>	1	3.0
		2	3.0
		3	3.5
		Average	3.2

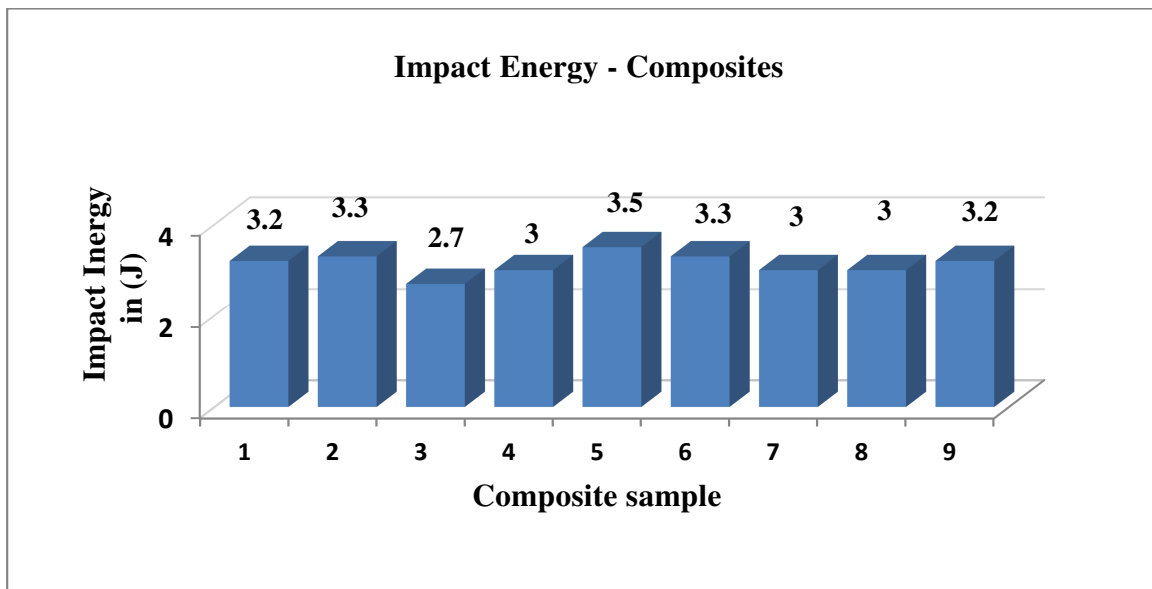

Figure 4.42 Impact energy of all nine composites

4.1.5 Water Absorption Test Result

The water concentration test of the composite sample was performed to assess the material's resistance to water infiltration. At room temperature, the samples were investigated (21- 23C °). The steps for testing the specimen are listed below.

- ☞ Each specimen's weight was determined using a digital scale balance.
- ☞ The samples were all submerged in water for 24 hours.
- ☞ The samples were removed from the water after 24 hours and their mass was recorded.

The total weight prior to and afterwards soaking were computed, as well as the intake of water %, by applying the equation below.

$$\% \text{ of water absorption} = \frac{w_d - w_w}{w_d} \times 100\% \dots\dots\dots \text{eq.4.1}$$

Where; W_d is weight of dry sample

W_w is weight of wet samples

Table 4. 2 Water absorption test result

S. no	Composite Composition	Sample no.	Water absorbtion (%)
1	<i>Enset 10%, coffee husk 10% and epoxy 80%</i>	1	3.23
		2	3.39
		3	3.45
		Average	3.35
2	<i>Enset 5%, coffee husk 15% and epoxy 80%</i>	1	4.88
		2	4.08
		3	5.77
		Average	4.91
3	<i>Enset 15%, coffee husk 5% and epoxy 80%</i>	1	3.77
		2	3.70
		3	1.79
		Average	3.09
4	<i>Enset 15%, coffee husk 15% and epoxy 70%</i>	1	5.26
		2	7.27
		3	3.70
		Average	5.41
5	<i>Enset 20%, coffee husk 10% and epoxy 70%</i>	1	3.36
		2	3.33
		3	3.98
		Average	3.55
6	<i>Enset 10%, coffee husk 20% and epoxy 70%</i>	1	3.70
		2	5.66

		3	6.12
		Average	5.16
7	<i>Enset 20%, coffee husk 20% and epoxy 60%</i>	1	12.12
		2	11.11
		3	10.13
		Average	11.12
8	<i>Enset 30%, coffee husk 10% and epoxy 60%</i>	1	6.67
		2	13.04
		3	12.28
		Average	10.66
9	<i>Enset 10%, coffee husk 30% and epoxy 60%</i>	1	9.52
		2	6.56
		3	16.00
		Average	10.69

4.2 Discussions

4.2.1 Tensile Test Discussion

The tensile strength property of each composite specimen fabricated was determined using the results of specimen samples and their average values. The composite with the peak tensile strength of 43.3 MPa is C5, which is composed of Enset 20%, Coffee husk 10%, and Epoxy 70%. With a tensile strength of 32.13MPa, the fiber composition (Enset 15%, Coffee Husk 5%, and Epoxy 80%) is the subsequent maximum. This reveals that the optimal fiber-matrix mix is a combination of Enset and Coffee husk with epoxy resin as a matrix.

Changing the fiber-matrix and fiber-fiber compositions have an influence on the tensile characteristics of the hybridised composite in general. An optimal tensile strength for

treated Enset-Coffee husk fibre hybrid composite may be attained with the epoxy at 70% and raising the volumetric proportion of the Enset.

Furthermore, the obtained results show that increasing the volume percentage of coffee husk has a substantial influence on the yield strength of the hybrid material. The minimum tensile strength of the composite samples C4 and C9 with 20% and 30% volume fractions of coffee husk, respectively, are 14.94 MPa and 15.35 MPa.

4.2.2 Compression Test Discussion

Figure 4.30 depicts the compressive strength results, which show that C6, composite with Enset 10%, Coffee husk 20%, and Epoxy 70%, has the highest compressive strength with 23.25MPa. C9, a composite made up of Enset 10%, Coffee Husk 30%, and Epoxy 60%, has the next peak compressive strength with a value of 22.91MPa. It can be realized that raising the coffee husk volume ratio to achieve the best compressive strength was done at 20% and 30% coffee husk.

4.2.3 Flexural Strength Test Discussion

The three-point flexural experiment is a popular method for evaluating the physical characteristics of composite resin-reinforced components, particularly when bending forces are employed. As the amounts of enset fibre grew, the experiment steadily enhanced flexural strength.

$$\text{Section modulus } (W_b) = \frac{B * H^2}{6}$$

$$\text{Maximum bending moment } (M_{bmax}) = \frac{F_{max} * L}{4}$$

$$\delta_{bmax} = \frac{M_{bmax}}{W_b}$$

Where; B is width of specimen, H is thickness of specimen, F_{max} is maximum applied force, and L is span length.

As a result, C5 gets the highest score on this test. When compared to the other nine composite specimens, the flexural result from the enset 20%, coffee husk 10%, and Epoxy 70% composite is 93.38 MPa, which is the best composition. C5 has a slightly higher flexural strength of 89.32 MPa than composite C3. The composite with 10% treated enset, 30% coffee husk, and 60% Epoxy has the lowest achievable flexural strength of 48.79 MPa.

Rise in enset fibre composition from 15 to 20% on mass improved flexural strength by roughly 4.4%, but rising from 20% to 30% on weight decreased flexural strength by 8%. Thus, the 20% enset and 70% epoxy with 10% coffee husk fiber composition yielded the highest flexural strength.

4.2.4 Impact Test Discussion

The impact test is aimed at determining how a particular sample specimen will react to sudden stress, such as shock. The material's brittleness or toughness is determined by the test. A notched test piece is typically used, and the two most common methods are the Izod and the Charpy tests. The energy required to fracture the test piece is usually reported in ft. lbs. or KJ.

The Charpy impact test, commonly referred to as the Charpy v-notch test, is a standardized high-strain-rate test used to assess the level of energy a material takes upon fracture. The amount of energy absorbed is an indicator of a material's tenacity. It is frequently employed in industry since it is simple to plan and execute, and findings are rapid and inexpensive. A key drawback is that all outcomes are just comparative.

The best value, as determined by the Charpy machine, is 3.5J. This resulted in a C5 composite with enset at 20%, coffee husk at 10%, and epoxy at 70%. The next best composite proportion for impact is a C2 and C6 treated fiber hybrid composite with Enset 5%, coffee husk 15%, and Epoxy 80% and Enset 10%, coffee husk 20%, and Epoxy 70%, respectively. These findings and increases in coffee husk composition have the greatest impact value, and vice versa. Furthermore, the impact energy of all of the composites ranges from 2.7J to 3.55J.

4.2.5 Water Absorption Test Discussion

The maximum water absorption percentage of composite C7 with enset 20%, coffee husk 20%, and Epoxy 60% is 11.12%, while composite C9 with enset 10%, coffee husk 30%, and Epoxy 60% is 10.69%. Composite C3 has the minimum percentage of water absorption at 3.09 percent. The next lowest is made from a C1 mixture of 10% enset, 10% sisal, and 80% epoxy. When the water absorption of composites is examined, the composite with the higher fiber composition has a higher water absorption value than the composite with the smallest fiber composition, indicating that the highest resin has the lowest water absorption percentage.

Overall, the results of all nine tests show that Composite C5 (Enset 20%, Sisal 10%, and Epoxy 70%) outperforms the enset - coffee husk fiber reinforced epoxy composite in terms of mechanical and physical qualities, with a 3.55 water absorption percentage. This thesis also emphasizes compression and bending. Another physical factor to consider is water absorption. Based on the aforementioned important characteristics, the treated composite sample with Enset 20%, Sisal 10%, and Epoxy 70% was chosen as the good composite created.

4.3 Comparison of Results with Literatures

Despite the fact that no studies on enset and coffee husk as a hybrid composite have been conducted, In terms of applicability, existing research will support what was done and the results acquired in this study. The laboratory's findings for the chosen material were contrasted with the literature in this study. The chosen composition's outcome:

Tensile Strength = 43.30MPa

Flexural Strength = 93.38MPa

Compression Strength = 21.23MPa

Impact Strength =3.5J

Water Absorption = 3.55

Table 4. 3 The comparison of current work with others.

S	Material types	Proporti on	Tensile (Mpa)	Compre ssion (Mpa)	Flexural Mpa	Impac t Jule	% Water absorptio n	Researchers
1	Coffee husk /PP	80/20	24.2	-	21.5	-	-	Manikandan. I Vijaykumar .G [6]
2	PVAc/False banana /saw dust	40/20/40	12.54	7.03	5.13	-	25.13%	Yerdaw.Z and Gedion. K[72]
3	False banana /gypsum	20/80	59.01	-	42.22	0.5	-	Ashenafi .A, Habtamu .M[72]
4	Banana- coir	20/80	16.43		20.52	0.76		T. Hariprasad1, G. DharmalingaM[61]
5	E/CH/epoxy	20/10/70	43.30	21.23	93.38	3.55	3.55%	Current work

4.4 Simulation of Bajaj Qute RE60 Front Bumper

The overall description of Bajaj RE60 is specified in the table 4.3

Table 4. 4Specifacaton of Bajaj Qute RE60 [73].

Seating Capacity	3 and driver
Max Power	10.8hp @5500 rpm
Max Torque	16.1 Nm @ 4000 rpm
Kerb weight	451 kg
Gearbox speed	5 speed + 1(R)
Over all dimensions	length = 2752 mm
	width =1312 mm
	height = 1652 mm
Max. Speed	70 km/hr
Suspension Type	front- Twin Leading Arm
	rare -Semi Trailing Arm



Figure 4. 43 Bajaj Qute RE 60 overview[73].

Finite Element Modeling and Analysis

The ANSYS 19.2 Software program was used to analyze the BAJAJ QUTE RE60 bumper Material (E20/CH10/EP70) using FEM. ANSYS is an independent multipurpose mathematical modeling program that incorporates preliminary processing features such as geometry and meshing generation, along with the solver and subsequent processing features in an uniform visual user experience. Developing the model, implementing the boundary conditions and pressure, finding the solution, and assessing the results are the four separate processes in the generic Explicit Dynamics study of the bumper using ANSYS.

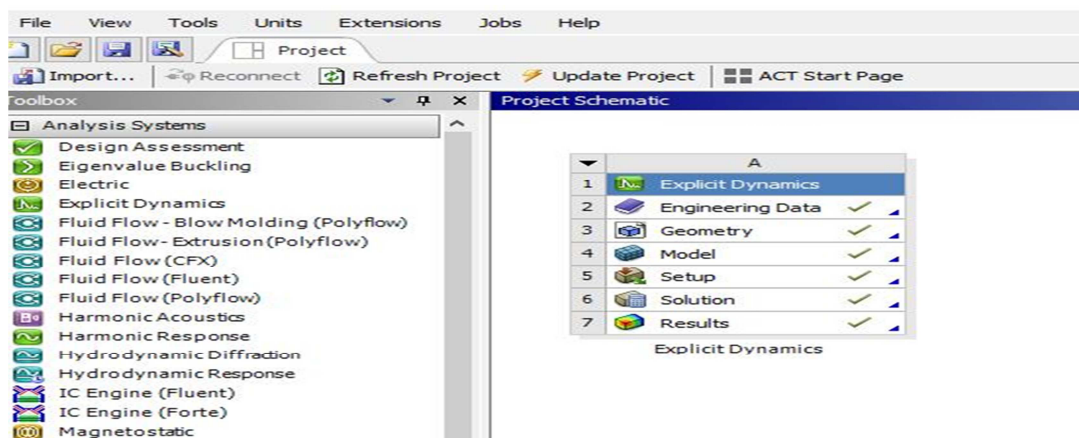

Figure 4. 44 Steps in ANSYS Analysis

Modeling, meshing, boundary and load application, and model analysis were all performed during the bumper analysis. The dynamics analysis was performed for equivalent stress and deformation.

4.4.1 Solid Works model of the Bajaj Qute RE60 front bumper.

The bumper model was created in SOLIDWORKS 2016 and imported into Ansys Workbench 19.2. Solid works is a 3D modeling application that works in conjunction with the ANSYS Workbench Software. The 3D model is analyzed as shell model in ANSYS. The overall size of the bumper was determined by directly measuring the existing bumper.

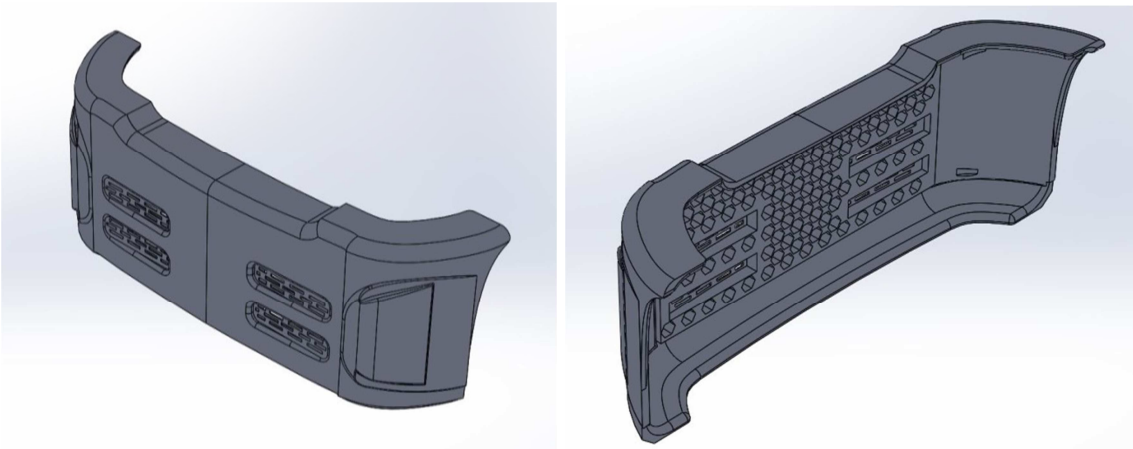

Figure 4. 45 Qute RE60 bumper 3D model.

4.4.2 Defining Engineering Data for the Material

The describing procedure in ANSYS is started by clicking the engineering tab at the top of the working space. Following the choice of this tab, a novel Materials that explains the material's name should be added. The new material for the bumper analysis was Enset - Coffee husk reinforced epoxy hybrid composite (E20%/CH10%/Ep70%). The following assumptions are made before entering the necessary data. The selected Qute RE60 bumper has a complicated shape. As a result, assumptions are required to make the simulation more realistic. As a result, the following assumptions are made:[74]

- ☞ the Qute bumper's shape was designed uniformly
- ☞ The material was considered to be linearly elastic and isotropic by considering all of the components of the fibre and matrix were blended evenly.
- ☞ void-free material
- ☞ perfect bind between matrix and
- ☞ all are fiber homogeneous

In this study, the chosen composite characteristics (E20/CH10/EP70) were added into the data. Density, tensile strength, compression strength, young's modulus, and Poisson's ratio are the parameters derived through laboratory testing and utilized as data for the computation.

Density = 1.1472 g/cm³

Young's modulus = 1951 MPa

Tensile Strength = 43.30MPa

Poisson's ratio = 0.274

Compression Strength = 21.23MPa

Outline of Schematic A2: Engineering Data				
	A	B	C	D
1	Contents of Engineering Data			Source
2	Material			Description
3	Enset - Coffee husk fiber reinforced Epoxy (E20%/CH10%/Ep70%)			C:\Users\Pc\Documents\FW.xml

Properties of Outline Row 3: Enset - Coffee husk fiber reinforced Epoxy (E20%/CH10%/Ep70%)				
	A	B	C	D
1	Property	Value	Unit	
2	Material Field Variables	Table		
3	Density	1.472	g cm ⁻³	
4	Isotropic Elasticity			
5	Derive from	Young's Modulus and Po...		
6	Young's Modulus	1951	MPa	
7	Poisson's Ratio	0.274		
8	Bulk Modulus	1.4388E+09	Pa	
9	Shear Modulus	7.657E+08	Pa	

Figure 4. 46 Flax/Sisal/Epoxy Material Engineering Data

4.4.3 Mesh Generation

Mesh is a persistent geometric region with arbitrary geometric and topological units. The meshing was fine-sized here, and the geometry's mesh settings had been customized to default. The Mesh module has a number of features for specifying mesh properties including mesh density, element shape, and element type. The total object has been meshing with 93450 elements and has created 25514 nodes.

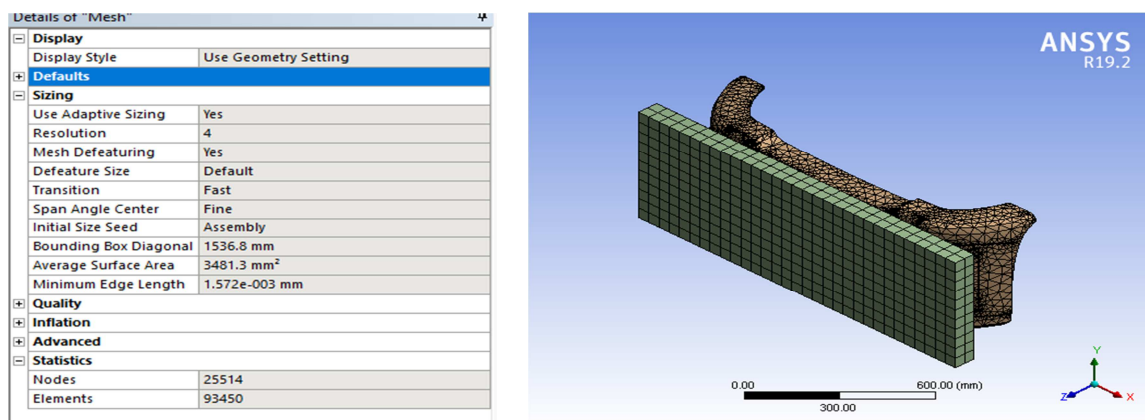

Figure 4. 47 Meshing details and Meshed front bumper Model

4.4.4 Inputs for Finite Element Analysis

The speed of the bumper serves as an input parameter for the FE computation. During execution, this input is used. In the scenario of analytical steps that operate on the bumper model and the predefined solid barrier, there are several variables. However, the major input in this scenario is the velocity of the bumper as a result of its displacement. Since the bumper is for low speed crash application the speed of the car was taken according to Ethiopia traffic management proclamation 208/2006 the speed of a car in city is limited to 30km/hr.

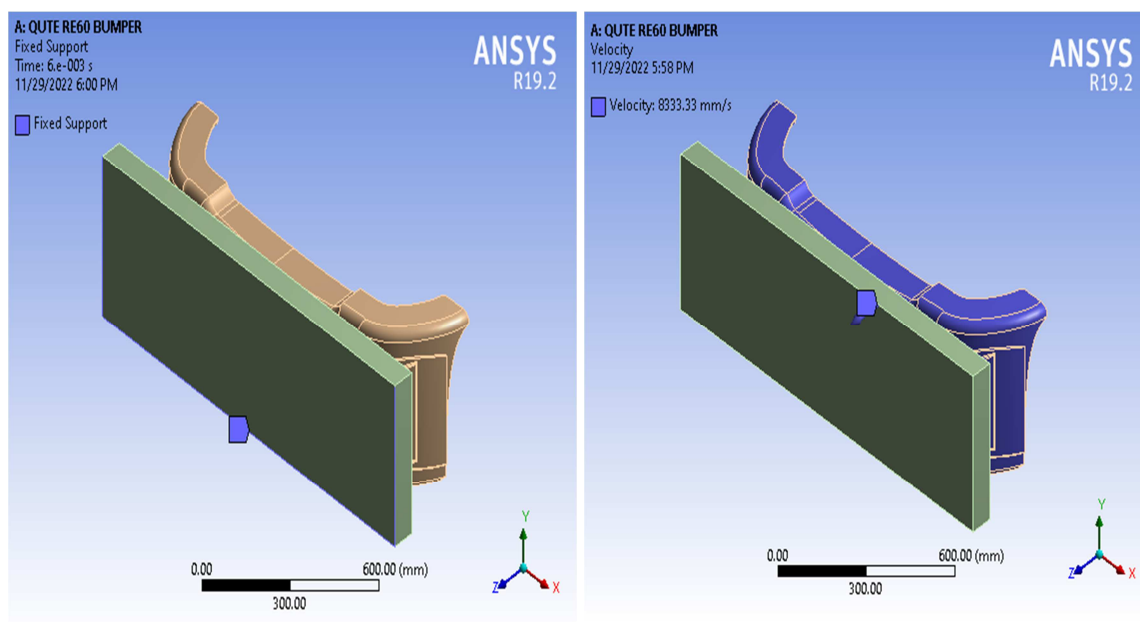

Figure 4. 48 Input parameters and boundary conditions

4.4.5 Applying Boundary Conditions and Load Conditions

Establish boundary constraints that significantly confine the sliding of the model's bottom ground and prohibit solid body action, thus preliminary boundary conditions and the predetermined velocity in the vertical direction (in Z-direction) are established at this phase. The boundary conditions are constructed utilising the motion on the Y-axis being confined, the solid wall's motion being locked to zero as a boundary condition, and in the predetermined having a velocity of 8.33m/s in the Z-axis.

4.4.6 Generating Solutions

Considering the specified criteria, the overall displacement, equivalent Elastic von Mises Stress was generated in this explicit dynamic analysis. The ANSYS19.2 tool is used to construct the finite element model and calculate its stresses and deformations. The bumper model's findings were obtained utilizing an Enset - Coffee husk epoxy hybrid. Geometry and velocity are considered. The explicit dynamic approach is mostly used to analyze the bumper model. It will also easily illustrate the bumper's performance.

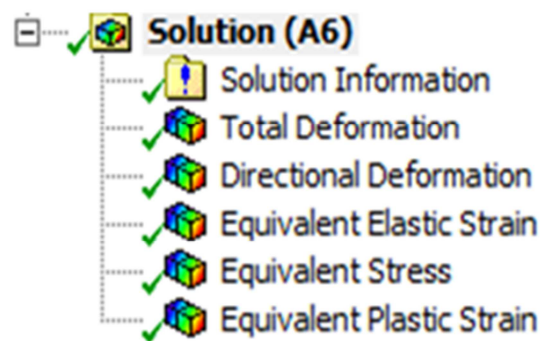

Figure 4. 49 Solution Tab

4.5 Result

Equivalent Von Misses Stress: The maximum equivalent von misses stress acquired for the Qute RE60 front bumper material of Enset/Coffee husk/epoxy hybrid composite is 39.119 MPa and the minimum value is 0 MPa.

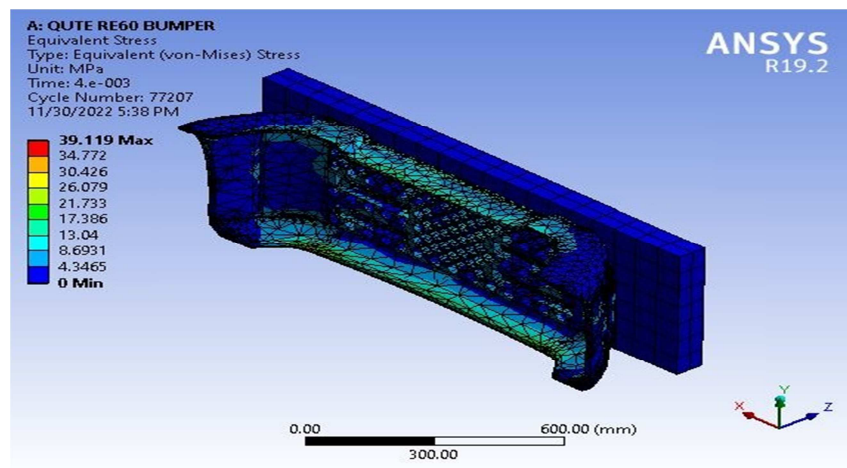

Figure 4. 50 Result of the Equivalent Von Misses Stress

Deformation: The maximum deformation achieved for the Qute RE60 front bumper material of Enset/Coffee husk/epoxy hybrid composite is 15.09mm and the minimum value is 6.2183mm.

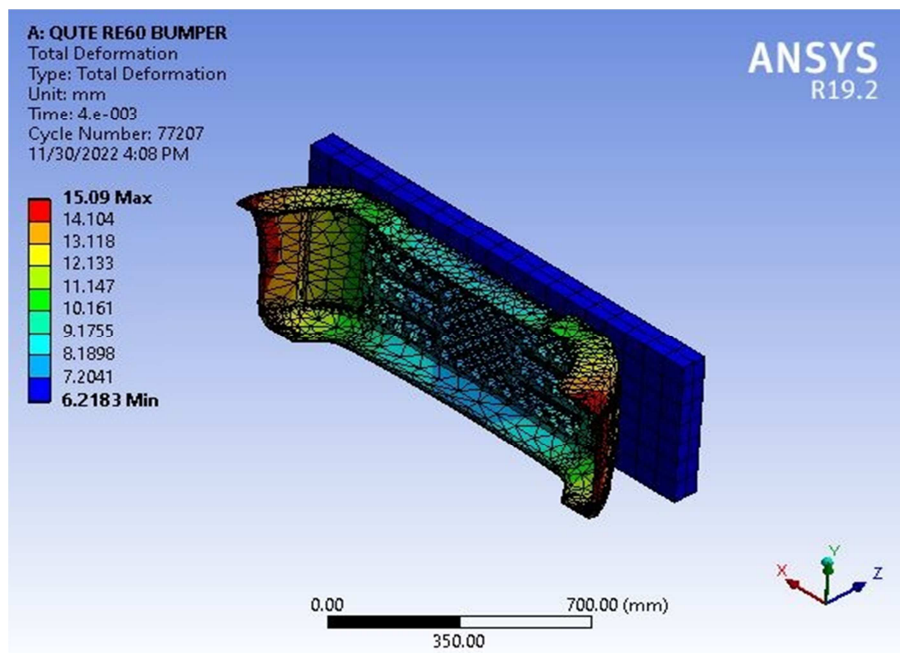

Figure 4. 51 Result of Deformation

4.6 Discussion

Employing the ANSYS Workstation tool and the criteria for the boundary, the imposed velocity is supplied along the impact plane towards the stationary barrier; afterwards the result for equivalent (von-Mises) stress and overall deformation is measured.

Equivalent Von Misses Stress: For design assessment, the Von Misses stress is regarded as acceptable. The Von Misses stress statistics indicates that the structure will be rejected if the highest value of Von Misses stress created in the material is greater than the material's strength. As a result, the von Misses stress is often employed to determine whether a structure can handle a particular load.

As the findings reveal, the bumper's rear face experiences the most stress. subsequently contrasted with the breaking strength of the component and the stress magnitude gained, Enset/Coffee husk/epoxy hybrid composite with a percentage of 20/10/70 appears to be

worthy of serving as an alternative for the traditional material utilized in the fabrication of the Qute RE60 front bumper, such as carbon, aluminum alloy, and high density PE foam.

Deformation: Overall deformation is the modification of a bumper model with a velocity implementation from its original or beginning shape to its present shape. The resulting displacement value is similarly extremely low, showing that the material can sustain the impact delivered at a low speed accident of 30km/hr. Furthermore, it demonstrates that the composite component can be an alternative for the existing material used in the production of the Qute RE60 front bumper.

Chapter Five

Conclusions and recommendations

4.7 Conclusions

This research focuses on the development of natural fiber hybrid composite for car front bumper. The most crucial factor to take into account throughout the design procedure is energy absorption. An ANSYS Workbench FEM tool is used to model and analyze the chosen model of Qute RE60 car frontal bumper. Because the bumper model is exposed to a crash velocity of 30 km/hr, the study employs solid barrier modeling. ANSYS Workbench 19.2 will be utilized to analyze the model employing an explicit dynamic technique. The bumper model utilized in the explicit dynamic study has a somewhat lower Von Misses stress and distortion. Because of the design of the model and the material employed in the research, the bumper provides the lowest von misses stress value and deformation throughout explicit dynamic computation. Because of the material's impact resistance, of the material, enset/coffee husk epoxy composite is good.

All the composite properties were imported from the experimental data gained by mechanical property test of the composite to ANSYS Workbench 19.2. Based on the preceding study, the study deduces that the employed composite material satisfies the majority of the criteria for high strength and stiffness in order to withstand the 30km/hr low speed crash/impact load. The Enset coffee husk hybrid epoxy composite bumper is used as the alternative material for front bumper.

The tensile, flexural, compression, impact, and water absorption characteristics of Enset/coffee husk/epoxy hybrid composites having various proportions were presented in this study. As an alternative material, it has also suggested an appropriate composition of 20% enset, 10% coffee husk, and 70% epoxy in which fibers are chopped in length (enset to 3-8mm and coffee husk 0.2-1.8mm) and treated with 5% NaOH. The following is the work's conclusion.

- Hand lay-up approach was used to successfully fabricate the hybrid composite utilizing enset - coffee husk fiber reinforced epoxy.
- The treated composite C5 with 20% enset, 10% coffee husk, and 70% epoxy composition had the maximum tensile strength of 43.30 MPa.
- The treated composite C5 with 20% enset, 10% coffee husk, and 70% epoxy composition had the maximum flexural strength of 93.38 MPa.
- The treated composite C6 with 10% enset, 20% coffee husk, and 70% epoxy composition had the highest compression strength of 23.25 MPa.
- The composite C5 with 20% enset, 10% coffee husk, and 70% epoxy composition had the highest impact strength of 3.55 J.
- The treated composite C3 with 5% enset, 15% coffee husk, and 80% epoxy composition had the lowest water absorption percentage of 3.09%.
- The material with 20% enset, 10% coffee husk, and 70% epoxy composition that is treated with 5% NaOH and chopped (enset to 3-8mm and coffee husk 0.2-1.8mm) reinforcement has superior mechanical and physical properties among the nine-specimen composite of enset/coffee husk/epoxy hybrid composite.
- The tensile strength of the suggested composition is 43.30 MPa, the compression strength is 21.23 MPa, the flexural strength is 93.38 MPa, the impact strength is 3.55J, and the water absorption percentage is 3.55%.
- The ANSYS modeling and analysis with the current material properties is completed successfully, with a maximum Von Mises stress value of 39.119 MPa and total deformation of 15.09 mm, which is less than the composite's strength.
- Finally, it can be concluded that an alternative material is an enset - coffee husk fiber reinforced epoxy composite with 20% enset, 10% coffee husk, and 70% epoxy.

As a result of the findings and comparisons of this investigation, the produced shredded Enset-coffee husk epoxy-reinforced composites exhibit acceptable mechanical characteristics and should be used for the lightweight front bumper.

4.8 Recommendation

Enset and coffee husk fiber reinforced matrix hybrid composites for vehicle front bumper applications are currently not used. To overcome constraints and achieve good mechanical properties, appropriate fiber extraction, hybridization, fiber surface modification, and manufacturing procedures should be used.

There were several challenges to overcome in developing Enset and coffee husk fibre reinforced matrix hybrid composites for automotive front bumpers. However, due to the wide range of bumper applications, the research is confined to the bumper analysis pertaining to the effect of collision velocity with a rigid body based on the existing and future use of vehicle front bumpers and global raw material shortages.

Because a better extraction method results in superior mechanical, physical, and thermal qualities, it's best to keep the extraction process moderate. Other than the manual layup procedure, a production technology was used. Examine different compositions and orientations of enset/coffee husk/epoxy. The chosen material is suggested for usage in a Qute RE60 front bumper low speed crash applications, since it has good qualities and can be utilized as alternative for synthetic fiber composites.

4.9 Future Work

There are numerous potential research areas for Enset/coffee husk/Epoxy hybrid composite. Some of them are listed below;

- ☞ Develop the composite bumper for other structural parts of vehicles.
- ☞ Hybrids the current fiber with synthetic fiber and develop new material.
- ☞ Investigate the thermal analysis of suggested material.
- ☞ Characterize and investigate the interfacial bonding between fiber and matrix.
- ☞ Investigate the fatigue failure of enset coffee husk fiber reinforced epoxy composite.
- ☞ Investigate the sound absorption and free vibration of the composite for automotive applications.

Reference

- [1] S. Tadesse, Experimental Investigation of Mechanical Performance of Hybrid Fiber Reinforced polymer Composites for Structural Application A Thesis Submitted in Fulfillment of the Requirements for the award of MSc . in Manufacturing System Engineering, (2019).
- [2] S.Y. Degefe, Finite Element Analysis of E-glass / Epoxy Composite for Automotive Structures, Addis Ababa Univ. Inst. Technol. Sch. Grad. Stud. (2015) 1–81.
- [3] B.S.R. and S.S.B. K Suneetha¹ *, A Ramanjaneya Reddy² , P Hussain³, Design and analysis of car bumper, Int. J. Mech. Eng. Reserachy Technol. 2 (2016) 30–42.
- [4] S.E.E. Profile, FE Analysis on Vehicle Bumper Using Different, Int. J. Mech. Eng. Res. ISSN 2249-0019 Vol. 4, Number 2 (2014), Pp. 99-110 © Res. India Publ. [Http//Www.Ripublication.Com](http://Www.Ripublication.Com). (2016).
- [5] L. Huang, B. Mu, X. Yi, S. Li, Q. Wang, Sustainable Use of Coffee Husks For Reinforcing Polyethylene Composites, J. Polym. Environ. 26 (2018) 48–58. <https://doi.org/10.1007/s10924-016-0917-x>.
- [6] M. Ilangovan, V. Guna, C. Hu, A. Takemura, Z. Leman, N. Reddy, Dehulled coffee husk-based biocomposites for green building materials, J. Thermoplast. Compos. Mater. 34 (2021) 1623–1638. <https://doi.org/10.1177/0892705719876308>.
- [7] Z. Simeneh, D. Wogaso, Development and Characterization of Hybrid Flax -Banana Fiber Reinforced Epoxy Composite for Ceiling Fan Blade Application A Thesis Submitted to the Graduate School of Addis Ababa University in Partial Fulfillment of the Requirements Degree of Masters of Sc, (2021).
- [8] P. Kesarwani, S.J. Jahan, K. Kesarwani, Composite : Classification and its manufacturing process, Int. J. Appl. Res. 1 (2015) 352–358. www.allresearchjournal.com.
- [9] M. Boopalan, M.J. Umopathy, P. Jenyfer, A Comparative Study on the Mechanical

- Properties of Jute and Sisal Fiber Reinforced Polymer Composites, *Silicon*. 4 (2012) 145–149. <https://doi.org/10.1007/s12633-012-9110-6>.
- [10] G. Neşer, Polymer based composites in marine use: History and future trends, *Procedia Eng.* 194 (2017) 19–24. <https://doi.org/10.1016/j.proeng.2017.08.111>.
- [11] T.P. Sathishkumar, J. Naveen, S. Satheeshkumar, Hybrid fiber reinforced polymer composites - A review, *J. Reinf. Plast. Compos.* 33 (2014) 454–471. <https://doi.org/10.1177/0731684413516393>.
- [12] A. Bitew, aysheshim bitew for doctor adisu, Bahirdar University, 2022.
- [13] P.P. Adrian, B.M. Gheorghe, Manufacturing Process and Applications of Composite Materials, *Ann. ORADEA Univ. Fascicle Manag. Technol. Eng.* XIX (IX), (2010). <https://doi.org/10.15660/auofmte.2010-2.1896>.
- [14] A. Cherouat, H. Borouchaki, Present state of the art of composite fabric forming: Geometrical and mechanical approaches, *Materials (Basel)*. 2 (2009) 1835–1857. <https://doi.org/10.3390/ma2041835>.
- [15] M. Maria, Advanced composite materials of the future in aerospace industry, *Incas Bull.* 5 (2013) 139–150. <https://doi.org/10.13111/2066-8201.2013.5.3.14>.
- [16] S. Syath Abuthakeer, R. Vasudaa, A. Nizamudeen, Application of Natural Fiber Composites in Engineering Industries: A Comparative Study, *Appl. Mech. Mater.* 854 (2016) 59–64. <https://doi.org/10.4028/www.scientific.net/amm.854.59>.
- [17] A.E. Bekele, H.G. Lemu, M.G. Jiru, Exploration of Mechanical Properties of Enset–Sisal Hybrid Polymer Composite, *Fibers*. 10 (2022). <https://doi.org/10.3390/fib10020014>.
- [18] L. Karikalan, M. Chandrasekran, S. Ramasubramanian, S. Baskar, Hybridization of Composites using Natural and Synthetic Fibers for Automotive Application, *Ijrst*. 3 (2019) 916–920.
- [19] R. Ramasubbu, S. Madasamy, Fabrication of Automobile Component Using

- Hybrid Natural Fiber Reinforced Polymer Composite, *J. Nat. Fibers*. 19 (2022) 736–746. <https://doi.org/10.1080/15440478.2020.1761927>.
- [20] J. Aboudi, S. Arnold, B. Bednarczyk, *Micromechanics of Composite Materials*, 2013. <https://doi.org/10.1016/C2011-0-05224-9>.
- [21] W. Ouarhim, N. Zari, R. Bouhfid, A.E.K. Qaiss, Mechanical performance of natural fibers-based thermosetting composites, *Mech. Phys. Test. Biocomposites, Fibre-Reinforced Compos. Hybrid Compos.* (2018) 43–60. <https://doi.org/10.1016/B978-0-08-102292-4.00003-5>.
- [22] L. Geo, *Fabrication, Characterization and Simulation of Flax-Sisal Fiber Reinforced Epoxy Hybrid Composite for Prosthetic Socket*, Addis Ababa Inst. Technol. (2021).
- [23] Mueta Argaw, *A Study on the Mechanical Properties of the Bamboo Fiber in Composite Material using a Numerical Analysis A Study on the Mechanical Properties of the Bamboo Fiber*, (2019).
- [24] G. Debebe, *Mechanical Characterization and water absorption Behavior of Woven Mat Glass Fiber / Epoxy Composite Materials Addis Ababa Institute of Technology School of Mechanical and Industrial Engineering Mechanical Characterization and water absorption Behavior of*, (2020).
- [25] A. Science, *Design and Fabrication of Bamboo Composite Door Design and Fabrication of Bamboo Composite*, (2019).
- [26] B. Tolessa, B. Singh, *Mechanical Properties of Natural Fiber Reinforced Hybrid Polymer Composites : A Review*, (2020) 2405–2412.
- [27] M.T. Submitted, *M. Engineering, M. Engineering, Development and Characterization of the Mechanical*, (2021).
- [28] J. Homeny, W.L. Vaughn, *Whisker-Reinforced Ceramic Matrix Composites*, *MRS Bull.* 12 (1987) 66–72. <https://doi.org/10.1557/S0883769400066987>.

- [29] M. Liben Co-Advisor, J. Bhaskaran, Fabrication and Experimental Analysis of False Banana Jute Glass Fibers Reinforced Hybrid Composite for Automotive Body Panel Application by Fasil Andargie Fenta A Thesis Submitted to DEPARTMENT of MECHANICAL SYSTEMS and VEHICLE ENGINEERING School of Mecha, (2020).
- [30] L. Mohammed, M.N.M. Ansari, G. Pua, M. Jawaid, M.S. Islam, A Review on Natural Fiber Reinforced Polymer Composite and Its Applications, *Int. J. Polym. Sci.* 2015 (2015). <https://doi.org/10.1155/2015/243947>.
- [31] B. Sujeet Kumar, S. Biswas, Study on Mechanical Behaviour of Banana Fiber Reinforced Epoxy Composites a Thesis Submitted in Partial Fulfillment of the Requirements for the Degree, (2014). <http://ethesis.nitrkl.ac.in/5886/1/E-76.pdf>.
- [32] S. Stephano, V.G. Thurbius Galdius, Fabrication of Hybrid Coconut Fibre With Epoxy Composite, *Int. J. Innov. Work. Eng. Technol.* (2017) 2455–5797.
- [33] S. S, Fabrication and Testing of Reinforced Natural Fiber, *Int. J. Res. Appl. Sci. Eng. Technol.* 6 (2018) 1402–1412. <https://doi.org/10.22214/ijraset.2018.5231>.
- [34] S. Chandgude, S. Salunkhe, In state of art: Mechanical behavior of natural fiber-based hybrid polymeric composites for application of automobile components, *Polym. Compos.* 42 (2021) 2678–2703. <https://doi.org/10.1002/pc.26045>.
- [35] T.B. Gemechu, Mechanical Property Characterization of False Banana/Glass Fiber Reinforced Hybrid Composite Materials for Wind Turbine Blades Under Fatigue Load, Addis Ababa Sci. Technol. Univ. (2019).
- [36] R. Singh, B. Singh, M. Gupta, H. Tarannum, Composite building materials from natural fibers/ agro-forest residues, *Indian J. Eng. Mater. Sci.* 27 (2020) 137–149.
- [37] O. Panda, A STUDY ON THE EFFECT OF FIBER PARAMETERS ON THE Prof . Sandhyarani Biswas, (n.d.).
- [38] M.R. Sanjay, S. Siengchin, J. Parameswaranpillai, M. Jawaid, C.I. Pruncu, A.

- Khan, A comprehensive review of techniques for natural fibers as reinforcement in composites: Preparation, processing and characterization, *Carbohydr. Polym.* 207 (2019) 108–121. <https://doi.org/10.1016/j.carbpol.2018.11.083>.
- [39] K.L. Pickering, M.G.A. Efendy, T.M. Le, A review of recent developments in natural fibre composites and their mechanical performance, *Compos. Part A Appl. Sci. Manuf.* 83 (2016) 98–112. <https://doi.org/10.1016/j.compositesa.2015.08.038>.
- [40] B. Seifu, B. Singh, J. Moera Gutu, D. Legesse, Mechanical behaviours of hybrid ensete/sisal fiber, reinforced polyethylene composite materials for injection moulding, *SN Appl. Sci.* 2 (2020). <https://doi.org/10.1007/s42452-020-2679-2>.
- [41] A.S. SAROYA, V. MEENA, STUDY OF MECHANICAL PROPERTIES OF HYBRID NATURAL FIBER COMPOSITE, (2011) 1–39.
- [42] M. Design, M. Tech, K. Kumar, N. Bhanuprakash, A Review on Different Types of Hybrid Composite Materials with Different Matrix Proportions, (2017) 1089–1093.
- [43] B. Ravishankar, S.K. Nayak, M.A. Kader, Hybrid composites for automotive applications – A review, *J. Reinf. Plast. Compos.* 38 (2019) 835–845. <https://doi.org/10.1177/0731684419849708>.
- [44] G. Blomme, Z. Yemataw, K. Tawle, V. Sinohin, L. Gueco, R. Kebede, A. Lalusin, Assessing enset fibre yield and quality for a wide range of enset [*Ensete ventricosum* (Welw.) Cheesman] landraces in Ethiopia, *Fruits.* 73 (2018) 328–341. <https://doi.org/10.17660/th2018/73.6.3>.
- [45] S.I. Habib, Manufacturing and Investigation on Mechanical Properties of False Banana Fiber and Glass Fiber Composite Material for Vehicles Body Panel, (2020).
- [46] Z. Tsegaye, B. Gizaw, COMMUNITY INDIGENOUS KNOWLEDGE ON TRADITIONAL FERMENTED ENSET PRODUCT PREPARATION AND UTILIZATION PRACTICE IN GEDEO, (2015).

- [47] S.A. Bekalo, H.W. Reinhardt, Fibers of coffee husk and hulls for the production of particleboard, *Mater. Struct. Constr.* 43 (2010) 1049–1060.
<https://doi.org/10.1617/s11527-009-9565-0>.
- [48] W. Sime, R. Kasirajan, S. Latebo, A. Mohammed, E. Seraw, Coffee Husk Highly Available in Ethiopia as an Alternative Waste Source for Biofuel Production, *Int. J. Sci. Eng. Res.* 8 (2017). <http://www.ijser.org>.
- [49] W.S. Summer, Development of an Automated Nanoparticles Spray System for Selectively Reinforcing Polymer Composites, University of Louisiana at Lafayette, 2014.
- [50] Y. Zeleke, G.K. Rotich, Design and Development of False Ceiling Board Using Polyvinyl Acetate (PVAc) Composite Reinforced with False Banana Fibres and Filled with Sawdust, *Int. J. Polym. Sci.* 2021 (2021). <https://doi.org/10.1155/2021/5542329>.
- [51] C. Dong, Review of natural fibre-reinforced hybrid composites, *J. Reinf. Plast. Compos.* 37 (2018) 331–348. <https://doi.org/10.1177/0731684417745368>.
- [52] B. Koohestani, A.K. Darban, P. Mokhtari, E. Yilmaz, E. Darezereshki, Comparison of different natural fiber treatments: a literature review, *Int. J. Environ. Sci. Technol.* 16 (2019) 629–642. <https://doi.org/10.1007/s13762-018-1890-9>.
- [53] M.R.M. Jamir, M.S.A. Majid, A. Khasri, Natural lightweight hybrid composites for aircraft structural applications, Elsevier Ltd, 2018. <https://doi.org/10.1016/B978-0-08-102131-6.00008-6>.
- [54] D.K.K. Cavalcanti, M.D. Banea, J.S.S. Neto, R.A.A. Lima, L.F.M. da Silva, R.J.C. Carbas, Mechanical characterization of intralaminar natural fibre-reinforced hybrid composites, *Compos. Part B Eng.* 175 (2019) 107149.
<https://doi.org/10.1016/j.compositesb.2019.107149>.
- [55] T. Batu, H.G. Lemu, Investigation of mechanical properties of false banana/glass fiber reinforced hybrid composite materials, *Results Mater.* 8 (2020) 100152.
<https://doi.org/10.1016/j.rinma.2020.100152>.

- [56] A. Komuraiah, N.S. Kumar, B.D. Prasad, Chemical Composition of Natural Fibers and its Influence on their Mechanical Properties, *Mech. Compos. Mater.* 50 (2014) 359–376. <https://doi.org/10.1007/s11029-014-9422-2>.
- [57] I. Mehamud, J. Raj, C. Zeleke, Fabrication and Mechanical Property Evaluation of Ethiopia Banana Fiber Reinforced Polymer Composites, *Adv. Res.* 7 (2016) 1–10. <https://doi.org/10.9734/air/2016/26991>.
- [58] M. Ramesh, K. Palanikumar, K.H. Reddy, Comparative evaluation on properties of hybrid glass fiber-sisal/jute reinforced epoxy composites, *Procedia Eng.* 51 (2013) 745–750. <https://doi.org/10.1016/j.proeng.2013.01.106>.
- [59] A.A. Betelie, Y.T. Megera, D.T. Redda, A. Sinclair, Experimental investigation of fracture toughness for treated sisal epoxy composite, *AIMS Mater. Sci.* 5 (2018) 93–104. <https://doi.org/10.3934/matersci.2018.1.93>.
- [60] A. Muniappan, R. Srinivasan, M.V.V. Sai Sandeep, N. Senthilkumar, P. V. Senthil, Mode-I fracture toughness analysis of coffee bean powder reinforced polymer composite, *Mater. Today Proc.* 21 (2020) 537–542. <https://doi.org/10.1016/j.matpr.2019.06.694>.
- [61] G.D. and P.P.R. T. Hariprasad¹, STUDY OF MECHANICAL PROPERTIES OF BANANA-COIR HYBRID COMPOSITE USING EXPERIMENTAL AND FEM TECHNIQUES, 4 (2013) 518–531.
- [62] R.S. Rana, A. Kumre, S. Rana, R. Purohit, Characterization of Properties of epoxy sisal / Glass Fiber Reinforced hybrid composite, *Mater. Today Proc.* 4 (2017) 5445–5451. <https://doi.org/10.1016/j.matpr.2017.05.056>.
- [63] M. Ghasemzadeh-Barvarz, C. Duchesne, D. Rodrigue, Mechanical, water absorption, and aging properties of polypropylene/flax/glass fiber hybrid composites, *J. Compos. Mater.* 49 (2015) 3781–3798. <https://doi.org/10.1177/0021998314568576>.
- [64] S.K. Nayak, S. Mohanty, S.K. Samal, Influence of short bamboo/glass fiber on the thermal, dynamic mechanical and rheological properties of polypropylene hybrid

- composites, *Mater. Sci. Eng. A.* 523 (2009) 32–38.
<https://doi.org/10.1016/j.msea.2009.06.020>.
- [65] L. G Keni, V. Singh, N. Singh, A. Thyagi, S. Kalburgi, K.N. Chethan, Conceptual design and analysis of a car bumper using finite element method, *Cogent Eng.* 8 (2021). <https://doi.org/10.1080/23311916.2021.1976480>.
- [66] R. (DEPARTMENT O.M.E. (Machine D.A.P. Arsi Phaneendra SKM Simhadri Kilari, M.V. GVP College of Engineering (A), Design and Analysis of Car Bumper By Varying Materials and Speeds, *Int. J. Eng. Sci. Comput.* 08 (2016) 4298–4305.
<http://ijesc.org/>.
- [67] S.E. Susilowati, D. Sumardiyanto, Assessing Mechanical Properties of Pineapple Leaf Fibre (PLF) Reinforced Composites for Automotive Applications, *Int. J. Compos. Mater.* 8 (2018) 57–63. <https://doi.org/10.5923/j.cmaterials.20180803.02>.
- [68] S. Mohanty, S.K. Nayak, S.K. Verma, S.S. Tripathy, Effect of MAPP as coupling agent on the performance of sisal-PP composites, *J. Reinf. Plast. Compos.* 23 (2004) 2047–2063. <https://doi.org/10.1177/0731684404041711>.
- [69] B. Farshid, V. Safdari, A. Nourbakhsh, S. Pilla, The effects of fiber length and fiber loading on the mechanical properties of wood-plastic (polypropylene) composites, *Turkish J. Agric. For.* 34 (2010) 191–196. <https://doi.org/10.3906/tar-0903-16>.
- [70] D.T. Balcha, B. Kulig, O. Hensel, E. Woldesenbet, Mechanical Properties of Enset Fibers Obtained from Different Breeds of Enset Plant, *World Acad. Sci. Eng. Technol. Int. J. Aerosp. Mech. Eng.* 15 (2021) 7–14.
- [71] T.A. Negawo, Y. Polat, F.N. Buyuknalcaci, A. Kilic, N. Saba, M. Jawaid, Mechanical, morphological, structural and dynamic mechanical properties of alkali treated Ensete stem fibers reinforced unsaturated polyester composites, *Compos. Struct.* 207 (2019) 589–597. <https://doi.org/10.1016/j.compstruct.2018.09.043>.
- [72] H.M. Ashenafi Abuye, Fabrication and Characterization of False Banana Fiber

Reinforced Gypsum Composite, IJSER. 11 (2017) 1568–1574.

- [73] C. Variant, E.N. Compliance, U. Reviews, Key Specification of Qute (RE60)
Top Model Specifications of Bajaj Qute (RE60) Full Specifications Of Bajaj Qute (RE60), (n.d.).
- [74] T. G/Michael, Design and Analysis of Bumper for Three Wheeled Vehicle
(Bajaj), A Thesis Submitt. to Sch. Grad. Stud. Addis Ababa Univ. Partial Fulfillment
Requir. Degree Masters Sci. Mech. Eng. (2017).