



ADDIS ABABA UNIVERSITY
ADDIS ABABA INSTITUTE OF TECHNOLOGY
SCHOOL OF MECHANICAL AND INDUSTRIAL ENGINEERING
GRADUATE STUDIES PROGRAM IN RAILWAY
ENGINEERING

**INVESTIGATION OF THERMO- STRUCTURAL BEHAVIOR OF
VENTILATION APPLICATION ON RAIL VEHICLE DISC BRAKE**

**A thesis submitted in accordance with the regulations
for the degree of Master of Science in Rolling Stock Engineering**

BY: Mohammed Kedir

ADVISOR: Dr. Ing. Demiss Alemu

May, 2015

APPROVED BY BOARD OF EXAMINERS:

Dr. Birhanu Besha	_____	_____
Head, Railway center	Signature	Date
Dr. Ing Demiss Alemu	_____	_____
Advisor	Signature	Date
Mr. Tsegaye Feleke (Msc)	_____	_____
External Examiner	Signature	Date
Mr. Habtamu Tkubet (Msc)	_____	_____
Internal Examiner	Signature	Date

DECLARATION

I, the undersigned, declare that this thesis is my original work and has not been presented for a degree, in this or any other university and all sources of material used for the thesis work have been fully acknowledged.

Mohammed Kedir

Name

Signature

Date

This thesis has been submitted for examination with my approved as a university advisor.

Dr. Ing Demiss Alemu

Name

Signature

Date

TABLE OF CONTENTS

ABSTRACT	I
AKNOWLEDGEMENT	II
LIST OF TABLES	III
LIST OF FIGURE	IV
CHAPTER ONE	1
INTRODUCTION	1
1.1 BACKGROUND	1
1.1.1 HISTORY OF DISC BRAKE	2
1.2 STATEMENT OF THE PROBLEM	6
1.3.1 GENERAL OBJECTIVE.....	9
1.3.2 SPECIFIC OBJECTIVE	9
1.4 SCOPE AND LIMITATION OF THE STUDY.....	9
1.5 SIGNIFICANCE OF THE RESEARCH	10
1.6 RESEARCH METHODOLOGY.....	11
1.7 THESIS STRUCTURE.....	12
CHAPTER TWO	13
REVIEW OF LITERATURE	13
2.1 RELATED RESEARCH	13
2.2 CONCLUSIONS FROM LITERATURE REVIEW	18
CHAPTER THREE	19
MODELING OF THERMO-MECHANICAL DISC BRAKE.....	19
3.1 TECHNICAL AND OPERATING CONDITION OF LOCOMOTIVE.....	19
3.2 THEORETICAL APPROACH TO RAIL VEHICLE DISC BRAKING CONDITION.....	21
3.2.1 LOCOMOTIVE BRAKING AND ANGULAR VELOCITY.....	21
3.2.2 BRAKING ENERGY OF LOCOMOTIVE.....	23
3.2.3 HEAT ENERGY.....	24
3.2.4 WORK OF FRICTION FORCE.....	24
3.2.5 HEAT FLUX ENTERING THE DISC.....	26
3.2.6 CONVECTIVE HEAT TRANSFER.....	26
3.3 CALCULATION OF RAIL VEHICLE DISC BRAKE.....	28
3.3.1 DETERMINATION OF THE LOAD CONDITIONS	28
3.3.2 WEIGHT TRANSFER DURING BRAKING.....	29

3.3.3 DETERMINATION OF PHYSICAL MODEL..... 32

3.3.4 DETERMINATION OF FRICTION SURFACE OF DISC 35

3.3.5 DETERMINATION OF HEAT FLUX 36

3.3.6 DETERMINATION OF CONVECTION HEAT TRANSFER COEFFICIENT 37

3.3.7 FORCE DETERMINATION FOR THE BRAKE CALIPER..... 38

CHAPTER FOUR..... 39

FINITE ELEMENT ANALYSIS OF LOCOMOTIVE DISC BRAKE 39

4.1 INTRODUCTION TO FINITE ELEMENT ANALYSIS 39

4.2 INTRODUCTION TO FEA SOFTWARE ANSYS..... 40

4.3 GENERAL ANALYSIS PROCEDURE IN ANSYS 40

4.3.1 GEOMETRICAL DEFINITION: 40

4.3.2 MODEL GENERATION: 41

4.3.3 DEFINE MATERIAL PROPERTIES 41

4.3.4 GENERATE MESH 41

4.3.5 FINITE ELEMENT GENERATION 42

4.3.6 BOUNDARY CONDITIONS AND LOADING..... 42

4.3.7 SOLUTION 42

4.3.8 POST-PROCESSOR 42

4.4 ANALYSIS OF LOCOMOTIVE DISC BRAKE USING ANSYS 14.5 43

4.4.1 ASSUMPTIONS..... 43

4.4.2 GEOMETRICAL MODEL..... 44

4.4.3 DEFINITION OF MATERIAL 45

4.4.4 MESHING 46

4.4.5 DEFINITION OF THE LOADS AND BOUNDARY CONDITIONS 48

5.1 TEMPERATURE DISTRIBUTION OF BRAKE DISC..... 51

5.2 THE DISTRIBUTION STATE OF TEMPERATURE RADIAL DIRECTION..... 54

5.4 THERMAL DEFORMATION 56

5.5 VON MISES STRESS DISTRIBUTION 61

5.6 REPEATED BRAKING..... 67

CHAPTER FIVE 68

CONCLUSION AND RECOMMENDATION..... 68

6. FUTURE STUDY..... 69

7. REFERENCE..... 70

ABSTRACT

In recent decades, disc brakes have increasingly become more popular and gradually found their ways in many different types of vehicles, ranging from light motorcycles to heavy road trucks or even trains. They offer several advantages over drum brakes, including better stopping performance (disc cooled readily), easier to control (not self-applying), less prone to brake fade, and quicker recovery from immersion, which largely contributed to their popularity. However, after long repetitive braking, brake fade could still set in and compromise the performance of a disc brake due to the change of friction characteristics caused by temperature rise and overheating of brake components. Overheated components could further lead to more problems such as thermal cracks, plastic deformation and the life span of a disc brake could be shortened as a result. Therefore, to accurately predict the temperature rise in a disc brake system is of eminent importance in the early design stage. Yet, owing to the interactions of several physical phenomena, prediction of disc brake performance is highly complicated. In this thesis, we were apply modeling to the thermomechanical behavior of the ventilated design of disc and the computational modeling is carried out using FEM .Ventilation applications on brake discs can significantly improve the brake system performance by reducing the heating of the discs. In this study, the thermal behaviors of ventilated brake disc configuration were investigated at repeated brake conditions in terms of heat generation and thermal stresses with finite element analysis. The results were compared with solid brake.

AKNOWLEDGEMENT

I express my deep sense of gratitude towards my advisors; Dr. Ing. Demis Alemu whose guidance and contributions of knowledge to this research led me towards completion .

I would like to express my gratitude to Ethiopian Railway Corporation for providing me the opportunity to study Railway Engineering as well as furnishing the necessary materials to perform this research.

I express my cordial gratitude to my parents for their unlimited support. Finally, I extend my sense of gratitude to all my friends who directly or indirectly help me in this endeavor.

LIST OF TABLES

1. Table 3.1: Properties of Air at 20°C -----	33
2. Table 3.2: Data for calculating heat flux -----	34
3. Table 3.3a: Dimension of disc and brake pad for ventilated Disc Brake -----	35
4. Table 3.3b: Dimension of disc and brake pad for Solid Disc Brake -----	36
5. Table 4.1: Material Properties of Grey Cast Iron Disc -----	46

LIST OF FIGURE

Figure 1.1 Schematic Diagram of Drum and Disc Brake -----3

Figure 1.2 Ventilated brake Disc – terminology ----- 4

Figure 1.3 Forms of Thermal Distortion ----- 7

Figure 3.1 HX1C Electric Locomotives ----- 19

Figure 3.2 Heat input during stop braking ----- 25

Figure 3.3 Co’ Co’ wheel set arrangement ----- 29

Figure 3.4 SF6N Bogies for Electrical Locomotives ----- 31

Figure 3.5 Low point traction rod Co’-Co’ bogie ----- 32

Figure 4.1a Geometric Models of Ventilated Disc ----- 44

Figure 4.1b Geometric Models of Solid Disc ----- 45

Figure 4.2a Meshed Model of Ventilated Disc ----- 47

Figure 4.2b Meshed Model of Solid Disc ----- 48

Figure 4.3 Force Acting on the Rubbing Surface of Ventilated Disc ----- 49

Figure 4.4 Thermal Loading of Convection ----- 50

Figure 5.1 Temperature Gradient on solid Disc Brake at 2s ----- 52

Figure 5.2 Temperature time curve in ventilated brake disc ----- 53

Figure 5.3 Temperature time curve in solid brake disc ----- 54

Figure 5.4 Temperature distributions in ventilated brake disc at 100s ----- 55

Figure 5.5 Temperature distributions in solid brake disc at 100s ----- 56

Figure 5.6a Total Deformation on ventilated Disc Brake ----- 57

Figure 5.6b Total Deformation on Solid Disc Brake ----- 59

Graph 5.6a Total deformations in ventilated disc brake ----- 58

Graph 5.6b Total deformations in solid disc brake ----- 60

Graph 5.7a Equivalent von mises stress in solid disc brake ----- 61

Graph 5.7b Equivalent von mises stress in ventilated disc brake----- 62

Figure 5.7 Equivalent von mises stress in ventilated disc brake----- 63

Figure 5.8 Equivalent von mises stress in solid disc brake ----- 64

Figure 5.9 Heat Flux on ventilated Disc Brake ----- 65

Figure 5.10 Heat Flux on the solid Disc Brake ----- 66

Figure 5.11 Repeated brake application ----- .67

CHAPTER ONE

INTRODUCTION

1.1 BACKGROUND

Early methods of stopping trains included reversing the locomotive engine and the use of wheel braking systems that were limited to the locomotive. During the 1860s, railway brakes were manually-operated by the brakeman, who applied or released them by turning a hand wheel that was positioned at the end of the car.

By the late 1880s, passenger trains were running as fast as fifty and sixty miles per hour. Rail lines, once local and isolated, had become interconnected so that freight cars could carry their goods across the country by being hitched to a succession of different trains with compatible coupling and braking systems.

Various patents for brake improvements featured apparatuses for linking the brakes between the cars and employed different methods for reducing slack in the brake line. These innovations made it possible for trains to become longer and to carry more cargo, as heavier trains require more stopping power. The most successful of the early continuous brakes used a chain link running through the length of the train that connected to a single control.

As the use of railways increased, the need for "automatic" brakes, which would engage in cases of accidental car uncoupling, grew more urgent. Railroad engineers grew quite inventive because of the proliferation of rail crashes involving cars that detached and ran downhill. Even a few chain brakes were designed to engage in cases like this, the tension in the chain functioning to keep a brake lever disengaged.

Steam brakes were among the early power brakes. Used on locomotives and their tenders, they had dual disadvantages: steam lost pressure as it cooled and the hoses carrying the steam would freeze up and clog with ice in cold climates. Steam pipes were not alone in their vulnerability to ice; it could handicap chain brakes as well.

Contemporary freight trains employ air brakes that use compressed air to keep a car's brakes disengaged. When air pressure drops in a car's reservoir the brakes apply automatically. George

Westinghouse patented his first air brake in 1869. He had difficulty persuading railroad officials that air could stop a train, but the efficiency of his system convinced detractors, and, by 1880, the Westinghouse automatic air brake had been installed on 2,211 locomotives and 7,224 cars in the United States. It was also used on rail locomotives and cars in Europe and Australia.

In 2005, the continent had a total railway network of 90,320 km or 3.1 km of per 1,000 km², most of which is disjointed. With the exception of North Africa, railways in Africa generally have a low level of traffic. The railways carry only one per cent of the global railway passenger traffic and two per cent of goods [1].

Ethiopia covers 1.1 M sq. km and it is vast to cover with only road transport. Addis Ababa's Transport problems are diverse aged fleet, chaotic movement of mini-bus taxis, environmentally unacceptable emission, and Unsafe, Hazardous to life and property [2].

1.1.1 HISTORY OF DISC BRAKE

Disc brakes were originally developed in the aircraft industry. They were introduced to the motor industry in the early 1950's on the Jaguar C-type, which used loose round pads, and then on the D-type, the first car to have discs on all wheels (six circular friction pads acting on each disc!). In the 1960's the disc began to enjoy more widespread utilisation superseding drum brakes (usually on front wheels only – where the braking load is more severe due to the weight transfer), because of its increased efficiency, low weight and improved 'fade' performance in comparison with drums. Brake 'fade' was a considerable problem with drum systems and meant that during heavy braking the vehicle would decelerate less rapidly towards the end of the stop, a dangerous and undesirable phenomenon. Disc brakes have become more and more popular and are currently found on the front wheels of virtually all passenger cars (drums usually being employed on the rear) and on all axles of many high performance vehicles. Many Commercial Vehicles also use discs, although their exposed nature can present problems in certain heavy duty environments. In addition many locomotives and rolling stock utilise disc brakes.

1.1.2 FOUNDATION BRAKE – TYPES

Historically there are two main methods of achieving this friction pair, both of which are still in common usage; drum brakes and disc brakes. Fig 1 shows schematically the operation of the two types. Braking with a drum brake is achieved by applying outward pressure with stationary friction pads (brake shoes' - stators) to the interior of a spinning drum (rotor). The pads oppose one another but drum distortion occurs and can take the form of 'ovalling' and 'barrelling'. Pad wear distribution depends on the actuating mechanism but it is not always uniform. The friction pair is enclosed within the drum which protects it from road debris but does nothing to encourage effective cooling.

In the case of the disc brake two stationary pads (stators) oppose each other across the thickness of the spinning disc (rotor). The disc is inherently much more exposed and better convective cooling is achieved even though the design is prone to the invasion of debris (dust shields can be fitted). In addition there is a shorter thermal path for heat to be conducted from the braking faces to the axle/wheel.

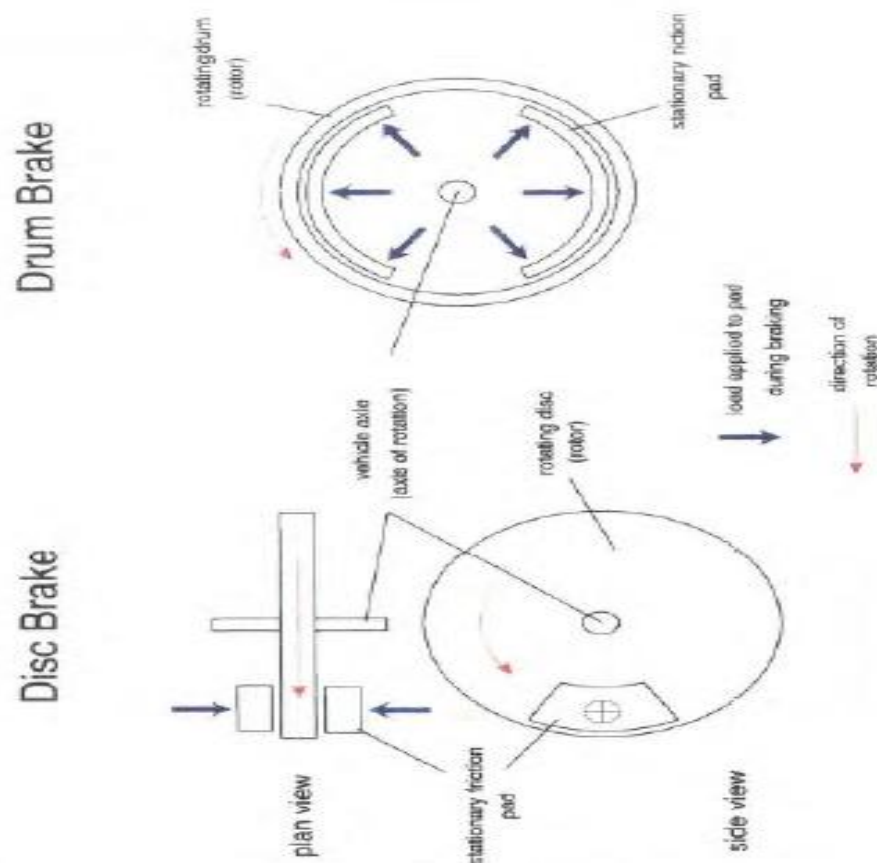

Figure 1.1 Schematic Diagram of Drum and Disc Brake

1.1.3 BRAKE DISC – OVERVIEW

There are two major types of car brake disc; solid and ventilated. The ventilated disc gives increased cooling ability without a proportional increase in weight, but it is more complex in its design and is not always necessary. In the case of high performance cars where a ventilated disc is required to achieve the desired heat transfer, the disc is commonly constructed of a cast iron hub and two annular braking faces, separated by radial ribs (also known as vanes). Air is able to flow through the air passages between the ribs, carrying heat away from the braking surfaces. A solid disc, as its name suggests, has no such air passages and as such has poorer cooling performance. Fig 2 shows a ventilated brake disc, its section and terminology.



Figure 1.2 Ventilating brake disc - terminology..

Brake pads convert the kinetic energy of the vehicle to thermal energy by friction. When the brake pad is heated up by coming into contact with the rotor disc to provide stopping power, it starts to transfer small amounts of friction materials to the disc or pad. However, in a disc brake system, there is no single material which has been able to meet the desired performance-related criteria such as safety and durability under various brake conditions [4]. The friction materials are required to provide a stable coefficient of friction and a low wear rate at various operating speeds, pressures, temperatures, and environmental conditions [4–7]. Furthermore, these materials must also be compatible with the rotor material in order to reduce its extensive wear, vibration, and noise during braking [6].

The prediction of disc brake performance is highly complicated. First, disc braking is a very dynamic and highly transient phenomenon in which extremely large temperature gradients can be generated at the vicinity of disc-pad interface in a fraction of a second during ad8 high-g deceleration and result in excessive thermal stresses, a phenomenon termed as “thermal shock”. Thermal shock can give rise to surface cracks and plastic deformation on the disc, making disc surfaces uneven. As a consequence, the heat dissipation area at the disc-pad interface is largely reduced and becomes non-uniform [3].

Frictional heating also produces thermal deformation and elastic contact which, in turn, largely affect the contact pressure and temperature on sliding interface. These phenomena are termed d“thermo mechanical coupling or thermo mechanical effects”, and are one of the major causes of creating hot spots on the sliding interface. Hot spots could further induce frictional vibration known as “judder”, which affects driving comfort and compromises driving safety if inexperienced drivers react to it improperly [8].

Second, asperities and wear particles can accumulate and form a thin layer called “third body” at the disc-pad interface. The presence of the third body not only changes friction properties at the disc-pad interface but also acts as a thermal resistance to the heat dissipated into the disc.

Third, as the application of disc brakes has been widened, the geometries of brake components are becoming more sophisticated. For example, the use of drilled-through holes and slots on disc is common in motorcycle’s disc brake systems, and pads made of individual elements have been widely employed on the disc brake systems of high-speed trains. This development toward complex geometry makes thermal analysis even more difficult.

The finite element method (FEM) has become the preferred method in performing thermal analysis on many systems and processes in recent years. There is a statement that thermal analysis is mostly performed using the finite element method, as this method has become a powerful tool for the numerical solutions of a wide range of engineering problems and dominates the methods of analysis. With the advances in computer technology and Computer Aided Design (CAD) systems, complex problems can be modeled relatively simply.

In this Thesis, the thermal behaviors of brake discs using two configurations will be investigated in repeated brake conditions in terms of heat generation and thermal stresses with finite element analysis. The results will be compared with solid disc brake.

1.2 STATEMENT OF THE PROBLEM

There are two types of distortion that can occur during brake operation. The first is due to the high mechanical forces on the disc during heavy braking and the transmission of the braking torque to the axle. The disc must be stiff enough to withstand these loads without raising internal stresses to a level where they either generate cracks or enter a plastic deformation region. The disc must be designed to remain within its elastic zone at all instances of operation, maintaining dimensional stability.

The second, and main, form of disc distortion is thermal deformation arising from large temperature differences across the disc due to heavy braking. Four basic types of thermal deformation occur in discs, and the three most significant are illustrated in Fig 3.

- i) **Radial expansion** - produces a radial displacement of the braking face at the position of the brake pads on the surface of the disc.
- ii) **Coning** - results in an axial deflection at the outer edge of the braking faces producing a conical deformation of the disc. This forces the pads apart slightly, changing the pressure distribution of the pad on the disc and hence creating an uneven heat input to the braking face. Braking effectiveness will be reduced as a result.

- iii) **Waving** - results in torque oscillations as the wheel turns, introducing instability to the braking system and a loss of smooth operation. This torque fluctuation also manifests itself in 'brake judder', a low frequency noise and vibration transmitted to the driver through the suspension, chassis and steering gear of the vehicle. This effect is easily detectable by the driver and is unacceptable in a modern production car. However its causes are not fully understood and its occurrence is of concern to rail vehicle industry.

- iv) **Rippling** - takes the form of localised deformation between the ventilation ribs due to the thermal stresses, and resulting strains, induced between the constraints of the ribs around the rotor braking face. This adversely affects pad contact pressure distribution and stability resulting in reduced braking efficiency and possibly in such effects as 'squeal' where a high frequency vibration of the pad is initiated causing loud, high-pitched noise during certain braking conditions.

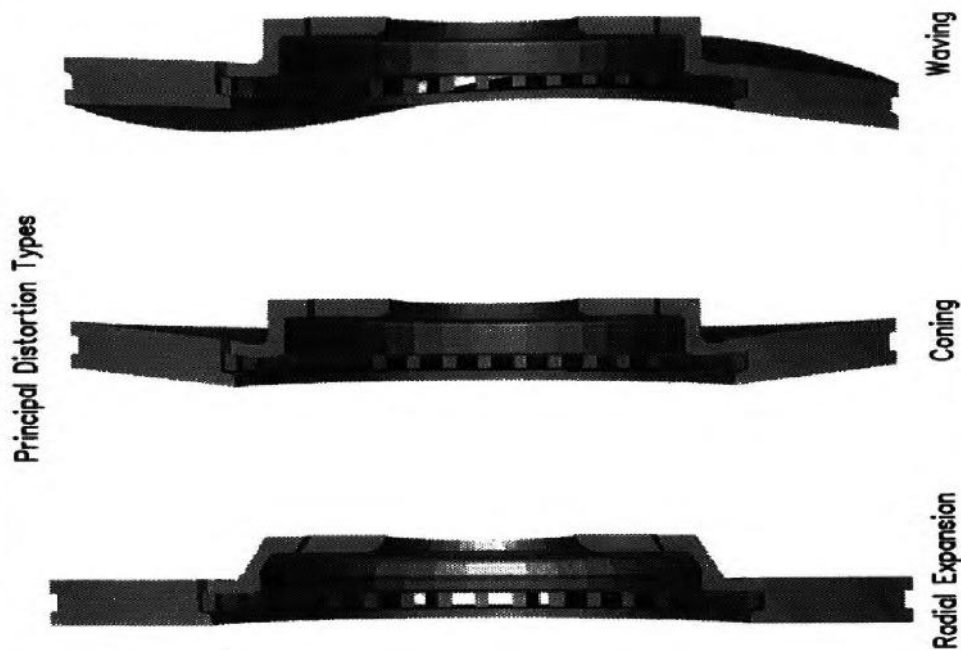

Figure 1.3 Forms of thermal deformation.

Waving and coning are the most important having the largest effect on braking performance. It is important that the disc must be designed to conduct heat to the hub effectively and without incurring large distortions such as those described above. It must also be able to lose heat to its surroundings by natural convection and it is very important that the material and design is able to withstand the continual thermal cycling without loss of performance or integrity.

1.3 OBJECTIVE OF THE PRESENT STUDY

1.3.1 GENERAL OBJECTIVE

To achieve the stated objectives of the research a detailed review of the relevant literature was completed.

The main objective of this study is :

- To investigate the thermal behaviors of ventilated brake discs using two configurations will be investigated at repeated brake conditions to improve braking performance.

1.3.2 SPECIFIC OBJECTIVE

- Thermal analysis and coupled structural analysis is carried out on a two configuration of disc brake.
- To investigate the mechanical and thermal stress in the ventilated disc brake during repeated brake based on finite element method and 3D thermo-mechanical coupling model is performed.
- Best combination of parameters of disc brake rotor like, wall thickness and material there by a best combination is suggested.

1.4 SCOPE AND LIMITATION OF THE STUDY

As it is seen in the problem statement. It is important that the disc must be designed to conduct heat to the hub effectively and without incurring large distortions. It must also be able to lose heat to its surroundings by natural convection and it is very important that the material and design is able to withstand the continual thermal cycling without loss of performance or integrity. This study is primarily focused on how heat dissipation from brake rotors can be improved by employing ventilation application at repeated braking condition in 3D thermomechanical modeling. Modeling and analysis of Thermo-mechanical stress of locomotive of disc brakes under specific loads and braking conditions were done.

Some of the limitation that might be encountered when conducting the research includes.

- Time: data collection, analysis will require more time to find good output. In general, this research may require ample time.
- Data: Finding the required data might not be available in neat and good justification.

The research will address the following questions:

- What are the main factors contributing to effective rail vehicle brake cooling?
- Can heat dissipation from rail vehicle disc brakes be increased by improved geometry brake?
- Can the thermal behavior of a brake rotor be improved by ventilation application?
- Are vented rotors better at heat dissipation, or are there times when a solid type rotor is better?

1.5 SIGNIFICANCE OF THE RESEARCH

As a research, the primary merits of the study goes to ERC future research center. Since there are a lot has to be done studies in the area, it will give a comprehensive starting point for more advanced researches. Students of the next batch will be motivated for further investigation of the best simulation. This will also develop awareness for the importance of research center in this field. Generally this research will be a great help to the ERC in promoting an efficient brake system design considering the prevailing facts that can alleviate the problem.

1.6 RESEARCH METHODOLOGY

1.6.1 LITRATURE REVIEW

- A journal, papers has been read up and part of it has been considered in this project. Meanwhile, To achieve more accurate numerical simulation results the actual real brake disc dimension has been taken from ERC specification for analysis purpose. Later, the precise dimensions have been used to translate in 3D brake disc drawing by using SOLIDWORK.

1.6.2 FINITE ELEMENT ANALYSIS

- Next, the 3D model of disc brake rotor has been transfer to finite element software which is ANSYS software. Thermal analysis will be done on transient responses under repeated brake application. Assigning material properties, load and tetrahedron mesh generation of the model will be done in. Finally an expected result of thermal analysis will be obtained.

1.6.3 PERFORMANCE EVALUATION

- The performance of the disc brake will be analyzed based on the Ansys analysis result of thermal nodal temperature and empirically calculated. So that from the result, this research checks the thermomechanical behavior of ventilated disk brake and compare with solid disk brake and from that the research decide how the rail vehicle disc brakes be increased by improved geometry brake to keep its performance improve further.

1.7 THESIS STRUCTURE

The structure of the thesis is as follows:

The first chapter is the introduction part which clearly states the background of the research, statement of problem, and objective, scope and limitation of the study, methodology.

Chapter two discusses Literature review of the disc brake system of rail vehicle will be discussed in this part of the study.

Chapter three the physical and mathematical model of locomotive disc brake as well as the material and boundary conditions are discussed in detail.

Chapter four deals about result and discussion of the result obtained after the simulation process using Ansys. This is done using numerical approach.

Conclusion and recommendation of the research on railroad vehicle brake system will be discussed and forwarded in chapter six. This will be the final chapter of the research.

CHAPTER TWO

REVIEW OF LITERATURE

2.1 RELATED RESEARCH

Ventilated brake discs or rotors are known as high performance brakes and are produced by making hollows or slots (or both) of different shapes on disc surfaces and side edges. Ventilated brake discs were originally tested on racing cars in the 1960s, and they have been employed widely in the automotive and railway industry using different designs [8, 9]. During braking, kinetic energy is converted to heat. Around 90% of this energy is absorbed by the brake disc and then transferred to ambient air. Solid brake discs dissipate heat slowly. Therefore, ventilated brake discs are used to improve cooling by facilitating air circulation [10, 11]. They generally exhibit convective heat transfer coefficients approximately twice as large as those associated with solid discs [12].

Limpert [13] compared solid and ventilated rotor thermal performance at higher rotor speeds, where in the internal cooling may contribute as much as 50 or 60 percent to the total cooling. Dufre'noy [19] proposed a macrostructural model of the thermomechanical behavior of the disk brake, taking into account the real three-dimensional geometry of the disk– pad couple. Contact surface variations, distortions and wear are taken into account. Real body geometry and thermoelastoplastic modeling of the disk material are specially introduced. Such a model aims to give predictions of the thermal gradients varying with time and of the thermomechanical response of the components. Predictions of the temperature distributions are compared with experimental measurements obtained by thermographs and thermocouples. Such a model seems to be a suitable base for the study of the thermal dissipation and the thermomechanical behavior and for the introduction of local friction effects. Parish and MacMauns [16] revealed the effects of disc geometry and rotating speed on the mean flow, passage turbulence intensity, and mass flow. The aerodynamic characteristics of the mass flow were found to be reasonably independent of rotational speed, but highly dependent upon rotor geometry. Johnson et al. [14, 12] used PIV (Particle Image Velocimetry) to measure air velocities through a high solidity radial flow fan utilized as a vented brake rotor. Sakamoto [18] analyzed the basic equations for heat convection, with brake tests and measurements of the flow through the fins. Repmann [17] examined a brake rotor geometry with straight angled cooling ducts through numerical studies by CFD (Computational Fluid Dynamics). Gao and Lin [9] presented an analytical model for

the determination of the contact temperature distribution on the working surface of a brake. To consider the effects of the moving heat source (the pad) with relative sliding speed variation, a transient finite element technique is used to characterize the temperature fields of the solid rotor with appropriate thermal boundary conditions. Numerical results shows that the operating characteristics of the brake exert an essentially influence on the surface temperature distribution and the maximal contact temperature. Choi and Lee [8] performed a transient thermoelastic analysis of disc brakes in repeated braking applications, using a finite element method with frictional heat generation. Newcomb et al. revealed that the thermal properties vary linearly with temperature [15]. Zhongzhe chi has performed the thermal characteristics of brake discs using analytical approaches on the assumption of laminar flow and simplified geometry [20]. The air flow through the passage of vane rotors is a complex turbulent flow. Thus, how to select better geometrical design variables and improve thermal performance of automotive brake rotors is a task that the vehicle designers are often confronted. This is because it is found that the thermal failure is not only due to high temperatures, but also due to high thermal stresses developed because of non-uniform cooling of rotor vanes. Thus it is difficult to determine the effects of geometries of rotors on thermal performance of disc brakes. David et al. have carried out the analysis for both flow surrounding the brake disc and inside the radial rotor passages using a two-component Particle Image Velocimetry (PIV) system [21]. Prediction of average heat transfer coefficient was in the past largely performed by using semi-empirical correlations [22] whereas recent attempts to predict it by CFD simulations can be found in the literature [23]. Anders et al. [24] has performed numerical simulation and compared the results with experimental data. Manohar et al. has validated the flow field velocities of a simple radial vane with the experimental data measured using PIV and modified the vane shape for maximum heat transfer [25]. Structural analysis of ventilated rotor brake discs using CAE, Finite Element Analysis (FEA) was reported in the literature [26]. In their study, they reported the procedure for prediction of thermo-mechanical performance like temperature distribution and heat transfer coefficient estimation. Blot, [27] defined several numerical procedures for the temperature analysis of brake discs and revealed that the FE technique was the fastest and most accurate for the investigation of brake disc performance. Furthermore, the time and cost of prototype manufacture and test could be significantly reduced.

Ali Belhocine, Mostefa Bouchetara [28], Train braking system is considered as one of the most fundamental safety-critical systems in modern vehicles as its main purpose is to stop or decelerate the vehicle. The frictional heat generated during braking application can cause numerous negative effects on the brake assembly such as brake fade, premature wear, thermal cracks and disc thickness variation (DTV). In the past, surface roughness and wear at the pad interface have rarely been considered in studies of thermal analysis of a disc brake assembly using finite element method. The ventilated pad-disc brake assembly was built by a 3D model with a thermo-mechanical coupling boundary condition and multi-body model technique. The numerical simulation for the coupled transient thermal field and stress field was carried out by sequentially thermal-structural coupled method based on ANSYS to evaluate the stress fields and of deformations which are established in the disc had with the pressure of the pads and in the conditions of tightening of the disc thus the contact pressures distributions field in the pads which is another significant aspect in this research.

The result shows, the Von Mises stress and the total deformations of the disc and contact pressures of the brake pads increase in a notable way when the thermal and mechanical aspects are coupled. The various interactions between the thermo-mechanical phenomena generally correspond to damage mechanisms: deformations generate cracking by tiredness, rupture or wear.

Ali Belhocine and Mostefa Bouchetara [29], the main purpose of this study is to analysis the thermo-mechanical behavior of the dry contact between the brake disc and pads during the braking phase. The thermal-structural analysis was then used coupling to determine the deformation and the Von Mises stress established in the disc, the contact pressure distribution in pads. The modeling was based on the ANSYS 11.0. The result was show that the ventilation system plays an important role in cooling disks and provides a good high temperature resistance. The analysis results showed that, temperature field and stress field in the process of braking phase were fully coupled. The temperature, Von Mises stress and the total deformations of the disc and contact pressures of the pads increases as the thermal stresses are additional to mechanical stress which causes the crack propagation and fracture of the bowl and wear of the disc and pads.

B. Ghadimi a., F. Kowsary and M. Khorami [30] In this study, a three dimensional model of brake disc R920K is modeled and its thermal behavior is investigated. The FEM and CFD results are verified with the experimental studies for emergency braking at $V \frac{1}{4} 154$ [km/h]. Because of the fluid flow characteristics and existence of wake regions, disc temperature at the top of the fins would be

greater than the temperature between the fins. Results show that the assumption of uniform cooling in the thermal analysis of brake disc is not realistic, hence the aerodynamic design of brake fins has critical role in the reduction of thermal stresses at the internal surface. Since there is a large delay or time lag for fins' temperature, no cooling occurred at the beginning of the braking. Therefore the surface temperature increases sharply at this time, thus the aerodynamic design has inconsiderable effect on the reduction of maximum temperature at the braking surface (against the thermal stresses).

Any comparison of the maximum temperature at different deceleration indicates that the 33 percent increase of braking distance leads to 6 percent reduction of the maximum temperature.

Daudi et al. [31] studied the influence of differing brake disc geometry and the type and number of fins on the cooling efficiency of a brake disc using CFD techniques and experimental airflow measurements. For the optimum design the resulting increased flow rate and air velocity through the vents led to increases of the Nusselt and Reynolds numbers which would increase the convective heat transfer coefficients.

McPhee and Johnson [32] employed experimental and analytical methods for better understanding of convection through the fin of a brake rotor. The experimental approach involved two aspects assessment of both heat transfer and fluid motion. A transient experiment was conducted to quantify the internal (fin) convection and external (rotor surface) convection terms for three nominal speeds. For given experiment conduction and radiation were determined to be negligible. Rotor rotating speed of 342, 684 and 1025 rpm yielded fin convection heat transfer coefficients of 27, 52.7, 78.3 $\text{Wm}^{-2} \text{K}^{-1}$, respectively a linear relationship. At the slowest speed, the internal convection represented 45.5% of the total heat transfer, increasing to 55.4% at 1025rpm. The flow aspect of the experiment involved the determination of velocity field through the internal passages formed by the radial fins. Utilizing PIV the phase-averaged velocity field was determined. A number of detrimental flow patterns were observed notably entrance effects and the presence of recirculation on suction side of the fins

There are numerous studies related to ventilation applications on brake discs. Zuber and Heidenreich [33] manufactured three different ventilated brake disc constructions from carbon fiber-reinforced ceramic matrix composites (CMC) and compared their strengths. Antanaitis and Rifici [34] proved that the 90-hole cross-drilled pattern improved heat rejection capability of the disc between 8.8% and 20.1% depending on the vehicle speed. Aleksendric et al. [35] showed the ability of a ventilated brake disc rotor in dissipating thermal flow by finite element analysis (FEA). Venkitachalam and Maharudrappa [36] conducted flow and heat transfer analysis of six different types of disc configurations by computational fluid dynamics (CFD) and recommended ventilated brake discs for high speed vehicles. Park et al. [37] designed a helical surface inside vanes for a ventilated brake disc. They optimized Reynolds (Re), Prandtl (Pr), and Nusselt (Nu) numbers for their design and obtained improvements to a maximum of 44% in heat transfer. Improvement in brake fade resistance and higher braking performance in wet conditions are some other useful aspects of ventilated brake discs. However, they also have some disadvantages. Cracking, is one of them and this a phenomenon that has been correlated to stresses during braking [38]. Kim et al. [39] showed the maximum von- Mises stress generation of actual fatigue cracks located on ventilated brake discs of railway vehicles by thermal stress analysis. Similarly, Bagnoli et al. [40] performed FEA to determine the temperature profile and to estimate the von- Mises stress distribution that arises during braking for fire-fighting vehicles. Hwang and Wu [41] investigated temperature and thermal stress in a ventilated brake disc based on a thermo-mechanical coupling model. Decreasing the brake temperatures and/or re-designing the hub-rotor unit were some considerable conclusions of Mackin et al. [42] to eliminate cracking in brake rotors. Heat generation also affects thermo-mechanical instability of brake discs [43]. In this thesis, different vented brake rotor models are generated and the corresponding numerical simulations are conducted, in order to investigate the effects of various geometrical parameters on the thermal performance. To evaluate the effect of stress, deformation and temperature gradient, the heat transfer coefficients are gradually increased by employing ventilation applications.

2.2 CONCLUSIONS FROM LITERATURE REVIEW

The considerable numbers of problems caused by excessive brake temperatures makes it an important topic of research, both from an economic and safety point of view. Although there has been numerous research in to the ventilation application aspect of brake cooling, it appears that there is further scope for improved cooling in this area. It is first necessary to understand the main parameters that effect the cooling of disc brakes, and establish how best cooling could be achieved. The current research illustrates that there are no clearly accepted methods of how to achieve optimal brake cooling. It was generally agreed that vented discs achieve superior cooling than solid discs, however according to Limpert (1975) [13] this may depend on the type of braking operation.

CHAPTER THREE

MODELING OF THERMO-MECHANICAL DISC BRAKE

In various research articles different modeling approaches for thermal analysis of disc brakes can be found. The models ranging from one–dimensional, two– dimensional, to complex three dimensional are used.

The three–dimensional, axi-symmetrical model of transient heat transfer has been chosen in this paper. It should be noticed that the geometry of a disc brake rotor is axi-symmetrical. In this case the assumption of axi-symmetric heat flux on the friction surface means only time averaged boundary conditions over a rotor revolution.

3.1 TECHNICAL AND OPERATING CONDITION OF LOCOMOTIVE

The Ethiopian Railway Corporation use to run the HX1C Class electric locomotive in the national railway line for freight transportation.

HXD1C electric locomotives are AC transmission electric locomotives for heavy-load freight transport on railway trunk lines. Based on the design concept of systematization, modularization and high-reliability, HXD1C locomotives are designed by integrating advanced technologies of AC transmission, microcomputer control, fault diagnosis, TCN network and electric-pneumatic braking. HXD1C locomotives are highly reliable and easy for maintenance.



Figure 3.1 HX1C Electric Locomotives [45]

The locomotive body is of wholly-bearing structure, with the center sill serving as the main traction transfer member; the bogie with low-level draw rod and the wheel-disc foundation brake effectively improves the locomotive reliability; the CCBII air braking system and regenerative electric brake are employed for energy conservation and environmental protection; the locomotive is applicable to traction by coupled operation of 2 locomotives and has LOCOTROL system interface reserved.

Main technical parameters:

- Purpose: Freight transport
- Gauge: 1435mm
- Electric transmission method: AC-DC-AC transmission
- Bogie type: SF 6N
- Axle arrangement: Co' - Co'
- Wheel diameter (New/half worn/fully-worn) : 1250mm/1200mm/1150 mm
- Locomotive service weight: 138 t (without additional weight); 150 t (with additional weight)
- Axle load: 23 t + 2 t
- Starting tractive effort: 520 kN (23t), 570 kN (25t)
- Continuous rated speed of locomotive: 120 km/h (23t), 100 km/h (25t)
- Continuous Tractive Effort of Locomotive
 - Axle load at 23t 370kN
 - Axle load at 25t 400kN
- Minimum radius of curvature negotiable: 125 m under the speed of 5 km/h
- Wheel Base: 2250mm + 2000 mm
- Locomotive Total Wheel Base: 16260 mm
- Locomotive length (Distance between front and rear coupler centers): 22670 mm
- Maximum width of locomotive body: 3,100 mm
- Maximum height (upon pantograph dropping): 4,760mm
- Double heading traction: the two locomotives can be subject to double heading traction and has LOCOTROL system interface reserved.
- Power supply system: AC 25 kV, 50 Hz
- Brake model: CCB II brake

- Braking control: electric braking, auto braking, separate electric pneumatic braking and spring energy accumulation stopping braking
- Mechanical brake: wheel disk brake
- Maximum continuous power at the wheel rim: 7,200 kW (traction and regenerative braking)
- Maximum electric braking force: 370 kN(23t), 400 kN(25t)
- Ambient temperature: $-25^{\circ}\text{C} \sim +40^{\circ}\text{C}$; preheating measures must be taken when the temperature varies from -40°C to -25°C .
- Transmission Ratio:6.235(106/17)

Operational parameters:

- Permissible Line velocity : 100km/hr
- Constant deceleration during of stop braking : 1.3889 m/s^2
- Maximum gradient of the line : 11%

3.2 THEORETICAL APPROACH TO RAILVEHICLE DISC BRAKING CONDITION

In the process of braking of railway vehicles, it is necessary to define a model of a thermal analysis that describes the heating transfer of the heat generated by friction at surfaces which are in contact, between a railway disc and braking pads, through the disc and pads, as well as heat outflow of the whole braking system due to cooling of the surrounding air.

For those purposes, an analytical model for analyzing thermal and mechanical stress effects in braking systems of rail vehicles is utilized and its adopted procedure is presented in this paper [46].

3.2.1 LOCOMOTIVE BRAKING AND ANGULAR VELOCITY

Brake Application is defined as an application of the brake that results in a brake force being applied to the vehicle. Brake force is the force applied to the brake disc / pad / braking surface interface [47].

The railway locomotive running with initial velocity (v_o) is supposed to stand still with constant deceleration (a). Its linear translational velocity as function of time (t) is given by:

$$\mathbf{v}(t) = \mathbf{v}_o - \mathbf{a}t \quad (3.1)$$

The angular velocity (ω) of the wheel set can be determined using:

$$\omega(t) = \frac{v(t)}{r_w} \quad (3.2)$$

$$\omega_o = \frac{v_o}{r_w} \quad (3.3)$$

Where,

v = velocity of the locomotive

v_o = Initial running velocity of the locomotive

ω_o = Initial angular velocity the wheel

ω = angular velocity of the wheel at any time

r_w = the radius of locomotive wheel

During the application brake, the brake force acts at the effective radius (r_{disc}) of the disc rotor. The translational velocity (v_{disc}) of this frictional force (F_{disc}) could be expressed in terms of the translational velocity $v(t)$ of the locomotive as follows.

$$v_{disc} = \frac{r_{disc}}{r_w} v(t) \quad (3.4)$$

The total braking time and distance can also be calculated by the formula:

$$S_b = v_o t_b - \frac{1}{2} a t_b^2 \quad (3.5)$$

$$t_b = \frac{v_o}{a} \quad (3.6)$$

Hence, angular velocity () at any time (t) could also be determined from:

$$\omega = \omega_o \left(1 - \frac{t}{t_b}\right) \quad (3.7)$$

Where,

t_b = brake time to stop the locomotive

S_b = total brake distance

3.2.2 BRAKING ENERGY OF LOCOMOTIVE

During the process of braking, available energy of the locomotive that must be transformed into frictional heat, need to be determined accurately. This study considers the kinetic as well as the potential (while running on slopes) energy of the locomotive that must be dissipated by the work of the braking. Rail vehicles have important masses in rotation. Therefore, the contribution of rotational kinetic energy is taken in to account.

The initial kinetic energy imposed in to the locomotive is given by the sum total of translational and rotational.

$$E_k = \frac{1}{2} M v_0^2 + \frac{1}{2} I \omega_0^2 \quad (3.8)$$

Where,

E_k = Initial Kinetic Energy of the locomotive just before braking starts

M = Mass of the locomotive

I = Polar inertial moment of rotating parts

And, the moment of inertia of the rotating wheel set and discs can be calculated by using the equation below.

$$I = \sum_{i=1}^n m_i r_i^2 \quad (3.9)$$

Where,

m_i represents the masses of the wheel set and brake discs

r_i represents the rotation radius of the rotating parts from the center of rotation

For this case, all the rotating parts are fixed on the axle of the wheel set and the rotation axis could be taken as the tangent line joining the contact point of the rail heads with wheel set of the locomotive. It is the parallel to the axis of the wheel axle. Hence, the rotating radius is and equal to the radius of the wheel (r_w).Hence,

$$E_k = \frac{1}{2} M v_0^2 + \frac{1}{2} I \omega_0^2 = \frac{1}{2} M v_0^2 \left[1 + \frac{I}{M r_w^2} \right] = \frac{1}{2} (1.1) M v_0^2 \quad (3.10)$$

In Some literatures, the contribution of the rotating masses of the wheel set and discs is taken to be 10% the tare weight of the axle load of the locomotive [48]. The term $\left[\frac{I}{Mr_w^2} \right]$ accounts to the rotational masses involved and its value equals 0.1.

3.2.3 HEAT ENERGY

In braking system, the mechanical energy is transformed into heat energy. This energy is characterized by a total heating of the disc and the pads during the braking phase. The energy dissipated in the form of heat can generate rise in temperature ranging from 300°C to 800°C [50]. The heat quantity in contact area is the result of plastic micro-deformation generated by the friction forces between disc rotor and brake pad.

The total heat generated (Q_{gen}) in the brake system equals with the total mechanical energy (E_b) lost from the locomotive. Hence, considering the energy balance;

$$Q_{gen} = E_b \quad (3.13)$$

3.2.4 WORK OF FRICTION FORCE

When locomotive begins to brake, the train lost power and will stop by frictional forces. The imposed mechanical energy theoretically transformed to frictional heat.

The brake disc rotor has got two friction surfaces ($2A_b$) swept by the brake pads on both sides. Two friction forces ($2F_{disc}$) act on both faces of the disc at an effective radius (r_{disc}). These forces retard the movement of the locomotive.

The total heat flux is equal to:

$$\text{Total heat flux} = \frac{Q_{gen}}{2A_b} = \frac{E_b}{2A_b} \quad (3.14)$$

Where,

A_b = is the area swept by the brake pad at one face of the disc

S_{disc} = distance traveled by F_{disc} during the whole braking time

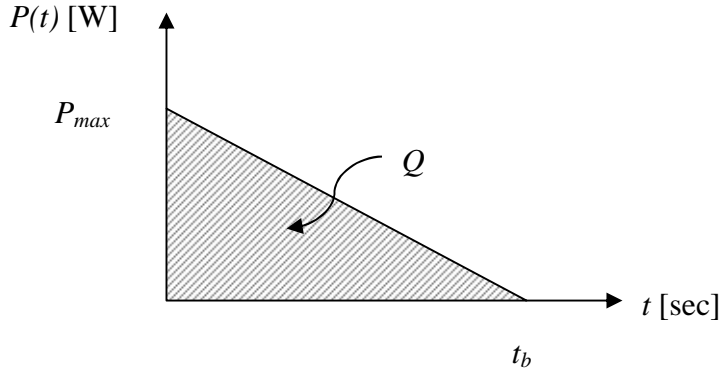

Figure 3.2 Heat input during stop braking

The total work of friction force during the whole brake cycle equals with the total heat generated.

$$Q_{gen} = E_b = \int_0^{t_b} P(t) dt \quad (3.15)$$

$$\frac{1}{2} M v_0^2 [1.1] = \int_0^{t_b} P(t) dt$$

$$\frac{1}{2} M v_0^2 [1.1] = (2F_{disc}) \int_0^{t_b} v_{disc}(t) dt$$

$$\frac{1}{2} M v_0^2 [1.1] = (2F_{disc}) \frac{r_{disc}}{r_{wheel}} \left[v_0 t_b - \frac{1}{2} a t_b^2 \right]$$

The friction force that work on the disc to retard the locomotive is:

$$F_{disc} = \frac{\frac{1}{2} M v_0^2 [1.1]}{2 \frac{r_{disc}}{r_{wheel}} \left[v_0 t_b - \frac{1}{2} a t_b^2 \right]} \quad (3.16)$$

In the present work, considering the amount of heat generation by wear is very small relative to the heat generated by friction, so the effect of material wear is neglected.

Therefore, using the value of the frictional force obtained above, the transient heat flux can be determined.

The heat power generated at the effective radius (r_{disc}) of the disc can be expressed as:

$$\dot{Q}(t) = (2F_{disc}) v_{disc} = 2F_{disc} \frac{r_{disc}}{r_{wheel}} (v_0 - at) \quad (3.17)$$

3.2.5 HEAT FLUX ENTERING THE DISC

The thermal analysis of the braking system of railway vehicles requires determination of the quantity of heat produced by friction, as well as the distribution of this energy between the railway disc and the braking pads.

Generally, the thermal conductivity of material of the brake pads is smaller than that of disc ($k_p < k_d$). We consider the energy from brake application is converted into heat and transferred to the disc and pad approximately 90% and 5% respectively [10,11]. During braking, kinetic energy is converted to heat. This ratio normally is called the proportion of heat transferred to disc ($\gamma = 0.9$). The rate of heat generation is:

$$\dot{Q}_d(t) = \gamma(2F_{disc})v_{disc} = (0.9)(2F_d)\frac{r_d}{r_w}(v_o - at) \quad (3.18)$$

Now focus on the railway disc rotor. The most of heat generated is characterized by the heating of the disc. Transient heat conduction in three dimensional heat transfer problem is governed by the following differential equation.

$$\frac{\partial^2 q_x}{\partial x^2} + \frac{\partial^2 q_x}{\partial y^2} + \frac{\partial^2 q_x}{\partial z^2} + \dot{Q} = \rho C_p \frac{\partial T}{\partial t} \quad (3.19)$$

Where q_x , q_y and q_z are conduction heat fluxes in x, y and z-directions, respectively, C_p is the specific heat, ρ is the specific mass, Q is internal heat generation rate per unit volume and T is the temperature that varies with the coordinates as well as the time t .

At the contact surface between the railway disc and the braking pads, the braking process produces heat according to expression (3.18).

3.2.6 CONVECTIVE HEAT TRANSFER

In order to accurately determine brake temperatures at a particular time (t) in the braking phase, knowledge of the heat transfer coefficient is required. The heat transfer coefficient (h) will depend on the airflow in the region of the brake rotor, and the vehicle speed. It will therefore vary constantly throughout the braking process. It is generally considered extremely difficult to obtain accurate values of the heat transfer coefficient, with errors of between 10 and 30% considered acceptable, (Limpert

1975). Limpert (1975) also presented empirical equations for heat transfer coefficients for both solid and vented rotors. These equations were obtained experimentally and are based on Reynolds number, with different forms for laminar and turbulent flow.

The current study assumed that heat dissipation from the brake disc to the atmosphere occurs via convection, also known as Newton's law of cooling. The convection heat transfer coefficient is applied to the body of the brake discs as the boundary condition. Thus, to increase heat transfer from the brake discs and to reduce the disc surface temperature on the total surface area of the brake discs, the heat transfer coefficients were gradually increased by employing ventilation applications.

Convective heat transfer between the air and the brake rotor surfaces is the primary mean of heat rejection. Radiation heat transfer is less important especially for the low surface temperatures and in this paper; its effect is neglected [50].

The evaluation of the convective heat transfer coefficient (h) is one of the most difficult tasks in the thermal analysis of a brake system. It varies over the brake surface and is a complex function of many factors such as geometry, air flow conditions, wheel angular velocity, surface temperature etc.

$$Q_{diss} = -h(T - T_{ref}) \quad (3.20)$$

Measurement of the airflow through the vanes of a vented rotor is extremely difficult while on the rail vehicle, so it is usually done in isolation, [see Hudson and Ruhl (1997) and Jerhamre and Bergstrom (2001)]. Limpert (1975) developed the following empirical equation from measurements of the flow through a series of vented rotors in isolation at varying speeds in still air:

$$V_{in} = 0.052\omega\sqrt{(D_{out} - D_{in})} \quad (3.21)$$

$$V_{av} = \frac{V_{in}}{2} \left(1 + \frac{A_{in}}{A_{out}} \right) \quad (3.22)$$

$$Re = (\rho d_h / \mu_a) V_{av}$$

Where

ω = rotational speed

V_{in} = air velocity at inlet (m/sec)

A_{in} = vent area inlet (m²)

A_{out} = vent area outlet (m²)

The heat transfer coefficient associated with laminar flow for solid or non-ventilated brake discs was derived by Eq. (3.23) (for $Re < 2.4 \times 10^5$) [57], where D is the outer diameter of the discs (m), Re is the Reynolds number, and k_a is the thermal conductivity of air ($W/m^\circ C$).

$$h_R = 0.70(k_a / D)Re^{0.55} \quad (3.23)$$

Meanwhile, the heat transfer coefficient associated with laminar flow for ventilated brake discs was approximated by Eq. (3.24) (for laminar flow condition, $Re < 10^4$) [57], where Pr is the Prandtl number, dh is the hydraulic diameter (m), and l is the length of the cooling vane (m). The hydraulic diameter (dh) is defined as the ratio of four times the cross-sectional flow area (wetted area) of the vane in ventilated brake discs.

$$h_R = 1.86(Re*Pr)^{(1/3)} (d_h/l)^{0.33}(k_a / d_h) \quad (3.24)$$

3.3 CALCULATION OF RAIL VEHICLE DISC BRAKE

The main problem of braking and stopping a heavy train system is the great input of heat flux into the disc in a very short time. Because of high temperature difference the material is exposed to high stress. The result is a heat shock. The problem can be solved only by applying a non stationary and numerical calculation.

3.3.1 DETERMINATION OF THE LOAD CONDITIONS

The specific loading condition in this analysis is the straight line braking of the locomotive running with a maximum velocity of 100 km/hr to standstill with the temperature of the surrounding temperature $40^\circ C$. The assumed temperature is average environmental temperature of the operating route of the locomotive in the region. The materials of the pad and the disc are isotropic and their thermophysical properties are temperature-independent;

- the coefficient of friction independent on temperature;
- the convective heat exchange with the surrounding air according to Newton's law of cooling the constant and average heat transfer coefficient h takes place on the exposed surfaces of the disc;
- radiation mode of heat transfer is ignored;

In this loading condition, the brake cycle dealt is with no recent brake application or previous warmed up of the disc had already been full dissipated to the ambient.

Hence, the initial temperature of the disc and the surrounding is the same (40°C).

The effect of the humidity in the air and the heat transfer with radiation is not considered.

3.3.2 WEIGHT TRANSFER DURING BRAKING

When a locomotive is standing still on straight track, its weight is uniformly distributed on all axles. On application of brakes on the vehicle, inertia forces are set up. The braking force is applied at lesser height where as the vehicle load is at a higher height. This creates a couple to act on the body of the vehicle which ultimately resulting an additional loading on leading bogie as compared to trailing bogie.

The SF 6N Bogie weight transfer mechanism

The SF 6 bogie family covers Co'-Co' wheel set arrangement of six axle bogies for electrical locomotives for standard gauge, broad gauge and narrow gauge. The SF 6N standard gauge bogie was developed for heavy freight trains.

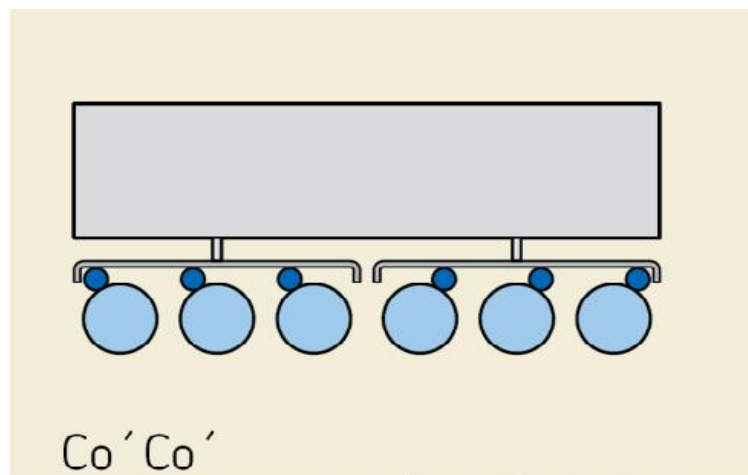

Figure 3.3 Co' Co' wheel set arrangement [52]

The wheel set arrangement classification is a systematic tool to sort railway vehicles by position of the wheel sets (axles), bogies and connections of vehicle bodies. There are several notations used to

describe wheel set and wheel arrangements, which vary by country. Within a given country, different notations may be employed for different kinds of locomotives, such as electric and diesel.

According to UIC classification scheme provided by the International Union of Railways and lay down in the UIC's "Leaflet 650 – Standard designation of axle arrangement on locomotives and multiple unit sets",

- Upper-case letters designate a number of consecutive driving axles, starting at "A" for a single axle. "C" thus indicates three consecutive pairs of driving wheels.
- Numbers designate consecutive non driving axles, starting with "1" for a single axle.
- Lower-case "o" designates axles, which are individually driven by electric traction motors in locomotives and multiple units.
- Prime sign "'" indicates that the axles are mounted on a bogie.

The bogie frames of the SF 6 bogie family consists of longitudinal girders, two head beams and two bogie centre beams, which form a closed frame. Pre cut parts are welded together to form a box section.

Each bogie wheel set is powered by a three-phase asynchronous motor. The bogie frame is supported on the axle bearing by helical springs. The primary springs of the first and last wheel set of every bogie are damped hydraulically.

The secondary suspension for each side frame consists of helical steel springs with low swiveling resistance fitted across the longitudinal axis of the vehicle. This arrangement prevents the introduction of torsional forces on the bogie frame.



Figure 3.4 SF6N Bogies for Electrical Locomotives [53]

The tractive effort transfer of all SF 6 bogies occurs via wear free traction rods which connect the main bogie centre bar to the car body.

The low point of impact on the bogie guarantees a fully equal wheel set load for heavy starts and thus also ensures an optimum tractive effort transfer with small wheel and track wear conditions.

In comparison with both outer wheel sets, the middle wheel set has a greater free lateral clearance in order to reduce the guidance forces in curves, especially those of the respective guiding wheel sets. The wheel set consists of two rolled solid wheels and a forged axle. The horizontally arranged axle guide conducts the tractive efforts from the wheel sets to the bogie frame and takes over the longitudinal guidance of the wheel set on the track.

All SF 6 bogies can be equipped with wheel flange lubrication, a sanding facility and rail guards. The bogies are prepared to carry the most important antennas for train protection according their operation area [52].

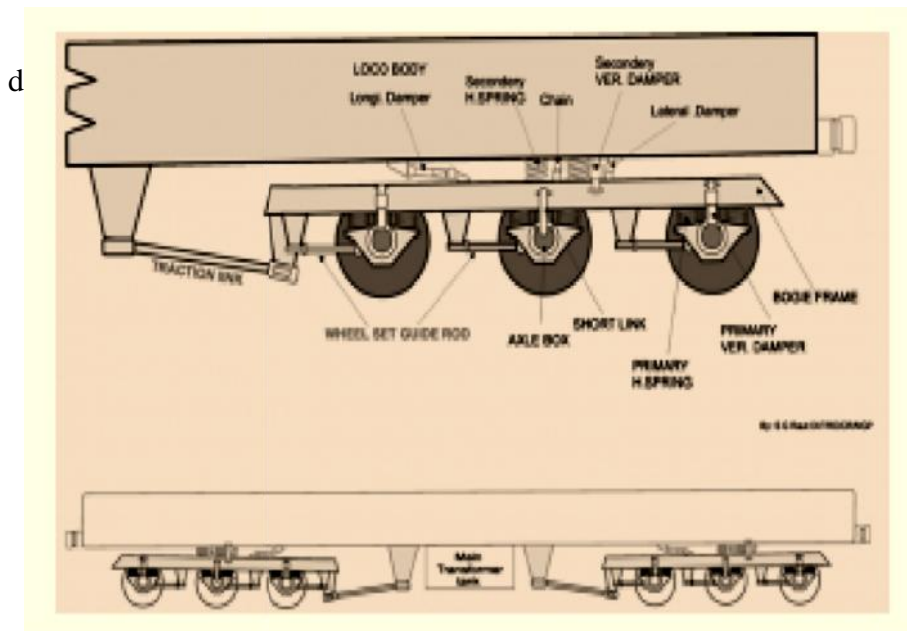

Figure 3.5 Low point traction rod Co'-Co' bogie [54]

Typical feature of these SF6N bogies are:

- It is a fabricated bogie and body weight is supported through helical springs six in number on each bogie.
- There is no centre pivot and braking/tractive effort from the bogie to body is transferred through low traction bar. The height of effort transfer reduced considerable resulting very low impact of weight transfer due to body. Rubber ring is used in the housing to absorb the shock of braking/tractive effort transfer.
- Cylindrical roller axle bearing with wing type axle boxes (SGCI) is used with primary helical spring on the wings. Wheel set guidance is flexible.
- Axle hung nose suspended motors with all nose in one direction

3.3.3 DETERMINATION OF PHYSICAL MODEL

Braking on the flat track derives from the physical model for determination of the heat transfer in dependency from the braking time. Beside that the weight distribution of the vehicle is considered. The weight arrangement is 60/40 [56] in the favor of the front part of the carriage. This means that the front part of the carriage takes 60% of the whole load. In our case only 10 % of the whole brake force is applied to one disc from the forward part of the carriage. Because of the mentioned weight

distribution, only the front part of the carriage is analyzed. Every carriage is consistent of for axles with two brake discs attached to each axle. The kinetic energy [56] for one wheel considering constant deceleration is:

$$0.1 \left[\frac{1}{2} M v_0^2 \right] = (2F_{disc}) \int_0^{t_b} v_{disc} dt \quad (3.18)$$

The change of energy is equal to the heat flux on the surface of the disc. This ratio is used to calculate the thermal load on the brake disc. Other operational data used for the analysis are listed in table 3.1.

Table 3.1 Properties of Air

<u>Temperature</u> - t - (°C)	<u>Density</u> - - (kg/m ³)	<u>Specific heat capacity</u> - C _p - (kJ/kg.K)	<u>Thermal conductivity</u> - k - (W/m.K)	<u>Kinematic viscosity</u> - - x 10 ⁻⁶ (m ² /s)	<u>Expansion coefficient</u> - b - x 10 ⁻³ (1/K)	<u>Prandtl's number</u> - P _r -
20	1.205	1.005	0.0257	15.11	3.43	0.713
40	1.127	1.0049	0.0271	16.97	3.20	0.711

Table 3.2 Data for calculating heat flux

Item	Values
Mass of the vehicle – M [kg]	70,000
Start velocity – v_0 [m/s]	27.7778
Deceleration – a [m/s ²]	1.3889
Braking time – t_b [s]	20
Effective radius of the braking disc – r_d [m]	0.2475
Radius of the wheel – r_w [m]	0.46
Friction coefficient disc/pad – μ [/]	0.36
Surface of the braking pad A_p – [cm ²]	225

The coefficient of friction has significant effects on the form of the thermal field, as well as on temperature distribution. The proper definition of the coefficient of friction is very important for perception of temperature field qualities for analyzing thermal effects in braking systems at railway discs. The value of the coefficient of friction depends on a number of tribological parameters such as speed of relative movement of parts in contact, the contact surface roughness, quality of materials of a tribo-pair, temperature of contact parts and so on [50].

However, this paper did not consider tribological parameters of braking processes. According to DIN EN ISO1183 the value $\mu = 0.36$ of the friction coefficient for materials of the disc and the pad for locomotives is taken as the recommended value.

3.3.4 DETERMINATION OF FRICTION SURFACE OF DISC

According to UIC 541-3 Standard, a Sinter material brake pad and Grey Cast Iron Disc with dimension tabulated in table 3.2a and 3.2b is used to calculate friction area swept on the disc by the brake pad.

Table 3.3a Dimension of disc and pad for ventilated disc brake

Description	Disc	Pad
Outer radius (R_o), [m]	0.320	0.320
Inner Radius (R_i)	0.175	0.175
Bolts hole Radius(13*9)		
Inner bore radius [m]	0.118	
Friction face Thickness (L)[m]	0.022	0.0265
Effective friction radius (r_{disc})[m]	0.2475	-
Friction surface (A_b, A_p)[m ²]	0.225	0.225

Table 3.3b Dimension of disc and pad for solid disc brake

Description	Disc	Pad
Outer radius (R _o), [m]	0.320	0.320
Inner Radius (R _i)	0.175	0.175
Bolts hole Radius(13*9)		
Inner bore radius [m]	0.118	
Friction face Thickness (L)[m]	0.0532	0.0532
Effective friction radius (r _{disc})[m]	0.2475	-
Friction surface (A _b , A _p)[m ²]	0.225	0.225

The effective radius is the intermediate friction surface radius of the disc $r_{disc} = 0.2475m$. The calculated contact surface area between the disc rotor and braking pad is $A_b = 0.225m^2$. But the friction surface of the pad is a given standard value.

3.3.5 DETERMINATION OF HEAT FLUX

The value of the friction Force which work on the brake disc is calculated below.

$$F_{disc} = \frac{0.1 * 0.9 \left\{ \frac{1}{2} M V_0^2 [1.1] \right\}}{2 \frac{r_{disc}}{r_{wheel}} \left[v_o t_b - \frac{1}{2} a t_b^2 \right]} = 9030N$$

The Instant heat flow entering brake disc:

$$(\dot{Q}(t)) = (2F_{disc})v_{disc} = ((0.9)(2F_{disc}) * r_d / r_w (v_o - at)) = 134960 - 6748t [W]$$

3.3.6 DETERMINATION OF CONVECTION HEAT TRANSFER COEFFICIENT

The heat transfer coefficient associated for solid brake discs was approximated by Eq. (3.21)

$$h_R = 0.70(k_a/D)Re^{0.55}$$

$$Re = 3.5 \times 10^4$$

$$h_R = \mathbf{10.54 \text{ w.k}^{-1}\text{m}^{-2} \text{ at } 40 \text{ }^\circ\text{c}}$$

.

The heat transfer coefficient associated for ventilated brake discs is calculated as follows.

V_{av} , average velocity.

.

$$V_{in} = 0.052 \sqrt{(D_{out} - D_{in})}$$

$$V_{in} = 1.682 \text{ m/s}$$

$$V_{av} = \frac{V_{in}}{2} \left(1 + \frac{A_{in}}{A_{out}} \right)$$

$$V_{av} = 1.1842 \text{ m/s}$$

$$Re = (d_h/\mu_a)V_{av}$$

$$Re = 1.79 \times 10^4$$

$$d_h = 0.022986 \text{ m}$$

$$h_R = 1.86(RePr)^{(1/3)} (d_h/l)^{0.33} (k_a/d_h)$$

$$h_R = \mathbf{14.52 \text{ w.k}^{-1}\text{m}^{-2} \text{ at } 40 \text{ }^\circ\text{c}}$$

3.3.7 FORCE DETERMINATION FOR THE BRAKE CALIPER

The surface pressure between the disc and pad, on behave of the calculated force applied to the disc, needs to be determined. Hence, brake caliper pressure is:

$$p = \frac{F_{disc}}{\mu A_p} = \frac{9030}{0.36 * 225 * 10^{-4}} = \mathbf{1.1148[MPa]}$$

Further simulation of a multiple braking was conducted according to the diagram shown in Figure 5.11, from which it can be seen that at the beginning, the single braking process takes place with the abovementioned parameters, then the brake is released and the speed increases linearly with time during 20 s. The cycle is repeated three times followed by the braking to standstill with the same deceleration as in the previous brake applications.

All the above calculated values are used throughout the finite element analysis

CHAPTER FOUR

FINITE ELEMENT ANALYSIS OF LOCOMOTIVE DISC BRAKE

Most numerical approaches on disc brakes preset a brake time or deceleration rate, in practice, the caliper press the pad onto the disc by pneumatic cylinders, the constant deceleration rate can be maintained.

For analyzing the process of braking, it is very useful to use FEM simulations based on the adopted analytical model for defining heat sources at surfaces which are in contact with disc rotor.

This study will use the FEA software ANSYS14.5 version to carry out transient thermal analysis and structural analysis of a railway disc during repeated braking conditions will be determined.

4.1 INTRODUCTION TO FINITE ELEMENT ANALYSIS

Finite Element Method is a numerical procedure for solving continuum mechanics of problem with accuracy acceptable to engineers. Finite Element Method is a mathematical modeling tool involving discretization of a continuous domain using building-block entities called finite elements connected to each other by nodes for force and moment transfer. This process includes Finite Element Modeling and Finite Element Analysis.

In displacement based FEM, stiffness of the entire structure (Part or assembly) is assembled from stiffness of individual elements. Loads and boundary conditions are applied at the nodes and the resulting sets of the simultaneous equations are solved using matrix methods and numerical techniques. In short, FEM is a numerical method to solve ordinary differential equations of equilibrium. Starting with simple linear static stress and heat transfer analysis, complex simulations involving highly non-linear, fluid flow and dynamic events can be successfully analyzed on a personal computer using a host of popular software like ANSYS. In practice, a finite element analysis usually consists of three principal steps.

Preprocessing: Create and discretize the solution domain into finite elements. This involves dividing the domain into sub-domains, called 'elements', and selecting points, called nodes, on the inter-element boundaries or in the interior of the elements. Assume a function to represent the behavior of the element. This function is approximate and continuous and is called the "shape function". Develop

equations for an element. Assemble the elements to represent the complete problem. Apply boundary conditions, initial conditions, and the loading.

Analysis: Solve a set of linear or nonlinear algebraic equations simultaneously to obtain nodal results, such as displacement values, or temperature values, depending on the type of problem.

Post processing: This stage involves processing the nodal data to get other information such as values of principal stresses, heat fluxes, temperature distribution, etc.

4.2 INTRODUCTION TO FEA SOFTWARE ANSYS

ANSYS is general-purpose finite element analysis (FEA) software package. Finite Element Analysis is a numerical method of deconstructing a complex system into very small pieces (of user-designated size) called elements. The software implements equations that govern the behavior of these elements and solves them all; creating a comprehensive explanation of how the system acts as a whole. These results then can be presented in tabular or graphical forms. This type of analysis is typically used for the design and optimization of a system far too complex to analyze by hand.

4.3 GENERAL ANALYSIS PROCEDURE IN ANSYS

Similar to solving problems analytically, it needs to define: the solution domain, the physical the model, the boundary conditions and the physical properties. Then solving the problem and present the results. In numerical methods, the main difference is an extra step called mesh generation. This is the step that divides the complex model into small elements that become solvable in an otherwise too complex situation. Below describes the procedure that need to be followed to carry out analysis using ANSYS software.

4.3.1 GEOMETRICAL DEFINITION:

There are four different geometric entities in pre processor namely key points, lines, areas and volumes. These entities can be used to obtain the geometric representation of the structure. All the entities are independent of other and have unique identification labels.

4.3.2 MODEL GENERATION:

Two different methods are used to generate a model: Direct generation and Solid modeling.

With solid modeling we can describe the geometric boundaries of the model, establish controls over the size and desired shape of the elements and then instruct ANSYS program to generate all the nodes and elements automatically.

By contrast, with the direct generation method, we determine the location of every node and size, shape and connectivity of every element prior to defining these entities in the ANSYS model. Although, some automatic data generation is possible (by using commands such as FILL, NGEN, EGEN etc) the direct generation method essentially a hands on numerical method that requires us to keep track of all the node numbers as we develop the finite element mesh. This detailed book keeping can become difficult for large models, giving scope for modeling errors. Solid modeling is usually more powerful and versatile than direct generation and is commonly preferred method of generating a model.

4.3.3 DEFINE MATERIAL PROPERTIES

All elements are defined by nodes, which have only their location defined. In the case of plate and shell elements there is no indication of thickness. This thickness can be given as element property. Property tables for a particular property set have to be input. Different types of elements have different properties. For instance, Beams: Cross sectional area, moment of inertia etc, Shells: Thickness Springs: Stiffness Solids: None.

The user also needs to define material properties of the elements. For linear static analysis, modules of elasticity and Poisson's ratio need to be provided. For heat transfer, coefficient of thermal expansion, densities etc are required. They can be given to the elements by the material property set.

4.3.4 GENERATE MESH

In the finite element analysis the basic concept is to analyze the structure, which is an assemblage of discrete pieces called elements, which are connected, together at a finite number of points called Nodes. Loading boundary conditions are then applied to these elements and nodes. A network of these elements is known as Mesh.

4.3.5 FINITE ELEMENT GENERATION

The maximum amount of time in a finite element analysis is spent on generating elements and nodal data. Pre processor allows the user to generate nodes and elements automatically at the same time allowing control over size and number of elements. There are various types of elements that can be mapped or generated on various geometric entities. The elements developed by various automatic element generation capabilities of pre processor can be checked element characteristics that may need to be verified before the finite element analysis for connectivity, distortion-index, etc. Generally, automatic mesh generating capabilities of pre processor are used rather than defining the nodes individually. If required, nodes can be defined easily by defining the allocations or by translating the existing nodes. Also one can plot, delete, or search nodes.

4.3.6 BOUNDARY CONDITIONS AND LOADING

After completion of the finite element model it has to constrain and load has to be applied to the model. User can define constraints and loads in various ways. All constraints and loads are assigned set 1D. This helps the user to keep track of load cases.

4.3.7 SOLUTION

The solution phase deals with the solution of the problem according to the problem definitions. All the tedious work of formulating and assembling of matrices are done by the computer and finally displacements and stress values are given as output. Some of the capabilities of the ANSYS are linear static analysis, non-linear static analysis, transient dynamic analysis, etc.

4.3.8 POST-PROCESSOR

It is a powerful user-friendly post-processing program using interactive color graphics. It has extensive plotting features for displaying the results obtained from the finite element analysis. One picture of the analysis results (i.e. the results in a visual form) can often reveal in seconds what would take an engineer hour to assess from a numerical output, say in tabular form. The engineer may also see the important aspects of the results that could be easily missed in a stack of numerical data. Employing state of art image enhancement techniques, facilities viewing of:

- Contours of stresses, displacements, temperatures, etc.

- Deform geometric plots
- Animated deformed shapes
- Time-history plots
- Solid sectioning
- Hidden line plot
- Light source shaded plot
- Boundary line plot etc.

The entire range of post processing options of different types of analysis can be accessed through the command/ menu mode there by giving the user added flexibility and convenience.

4.4 ANALYSIS OF LOCOMOTIVE DISC BRAKE USING ANSYS 14.5

The analysis is carried out for three dimensional solid and ventilated of the disc (Fig14.) (the disc is supposed to be symmetrical). In the zone of temporary contact of the pad and disc, the thermal flux is assigned, which differs in the area of disc at any instant of braking time corresponding to the components of the intensity of heat flux product Eq. (3.17).The numerical modeling of thermal effects was performed according to the following assumptions in ANSYS 14.5. work bench module.

4.4.1 ASSUMPTIONS

- Material properties are isotropic;
- The nominal surface of contact between the disc brake and the pad in operation is equal to the apparent surface in the sliding motion.
- The contact pressure is uniformly distributed over all friction surfaces hence the heat generation of the mid plane is considered as symmetric.
- The average of the intensity of heat flux into disc on the contact area equals.
- The heat transfer coefficient h is constant the time during simulation of braking process.
- Radiation is neglected by virtue of short braking time and hence relatively low temperature;
- The wear on the contact surface is negligible.
- Displacement in axial direction on flange is constrained in one side of the disc.

4.4.2 GEOMETRICAL MODEL

In the three-dimensional model of solid disc and ventilated disc , single surface of its symmetry in axial direction is not insulated owing nature of considered phenomenon of heating. The disc is screwed on the hub. It has twelve holes to fasten bolts. The geometry of the disc is illustrated in Fig 4.1a and Fig 4.1a.

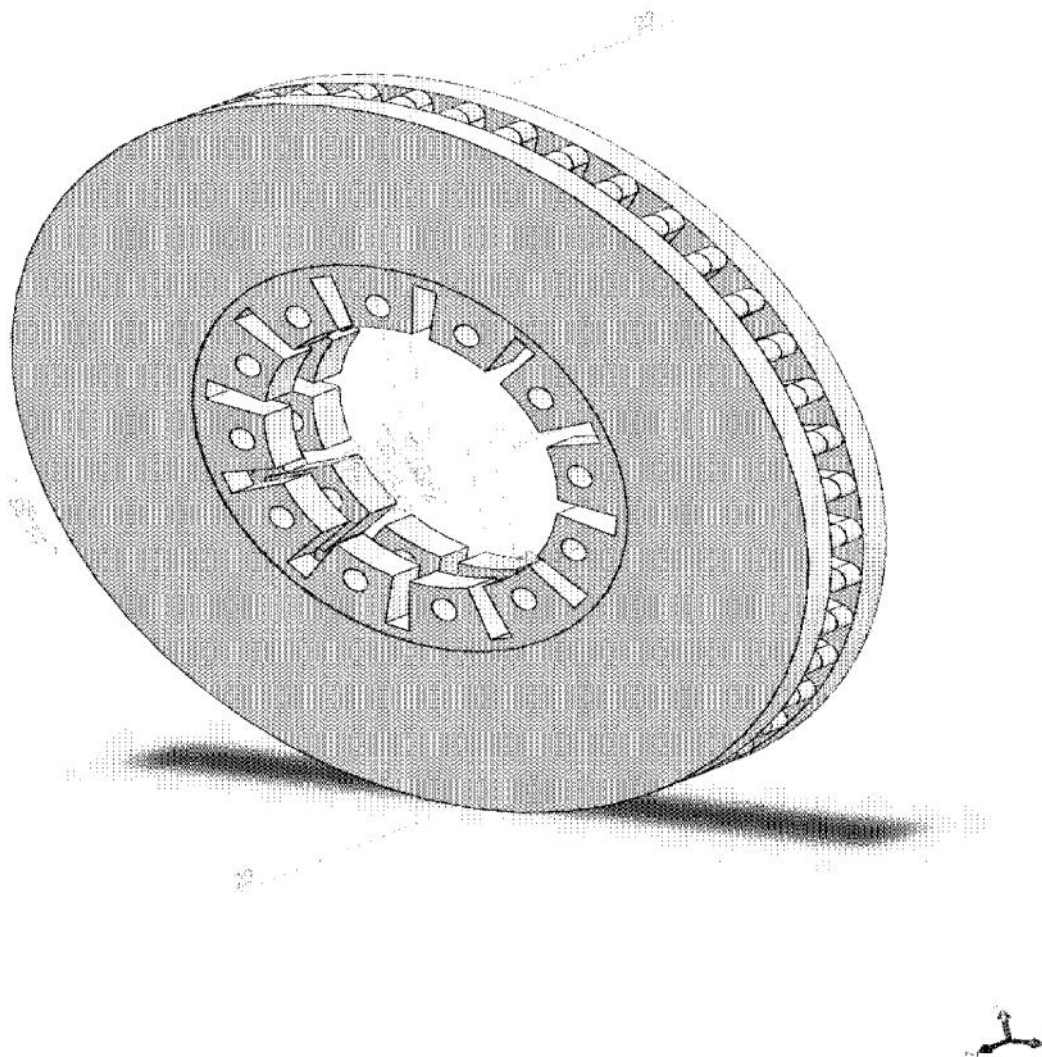

Figure 4.1a Geometric Models of ventilated Disc

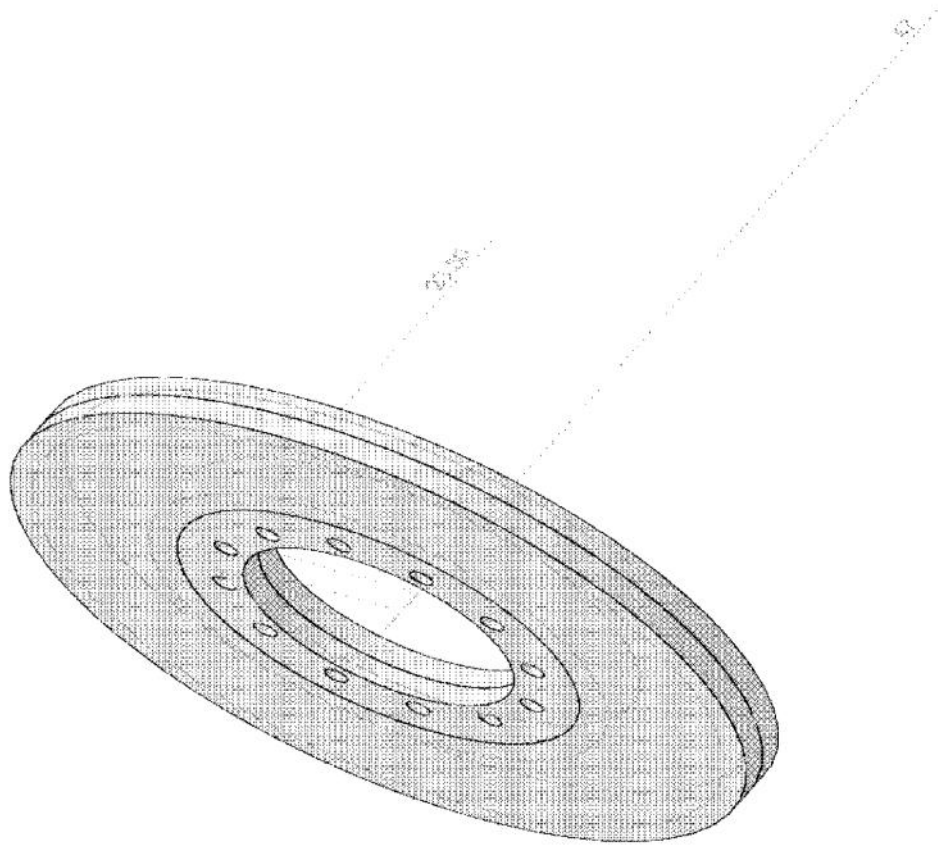

Figure 4.1b Geometric Models of solid Disc

4.4.3 DEFINITION OF MATERIAL

The material of locomotive disc material is gray cast iron (GFC) ISO standard with high carbon content [55], with good thermo physical characteristics and the brake pad has an isotropic elastic behavior, whose thermo-mechanical characteristics adopted in this simulation in the transient analysis is recapitulated in table 4.1.

Table 4.1 Material Properties of Grey Cast Iron Disc

Material Properties	Grey Cast Iron Disc
Thermal conductivity - k [W/m °C]	52
Density – [kg/m ³]	7200
Specific heat - c [J/Kg °C]	447
Poisson's ratio - ν	0.28
Elastic modulus - E [G Pa]	1.1×10^{11}

4.4.4 MESHING

In the finite element analysis the basic concept is to analyze the structure, which is an assemblage of discrete pieces called elements, which are connected, together at a finite number of points called nodes. A network of these elements is known as a mesh.

For this analysis, The model of brake disc was meshed with the tetrahedral finite element were used in ANSYS rather than defining the nodes individually (fig. 4.2a and b). The number of generated elements and nodes in the mesh for ventilated disc was 108587 and 61379 respectively. For that of solid disc was 108603 nodes and 64110 elements.

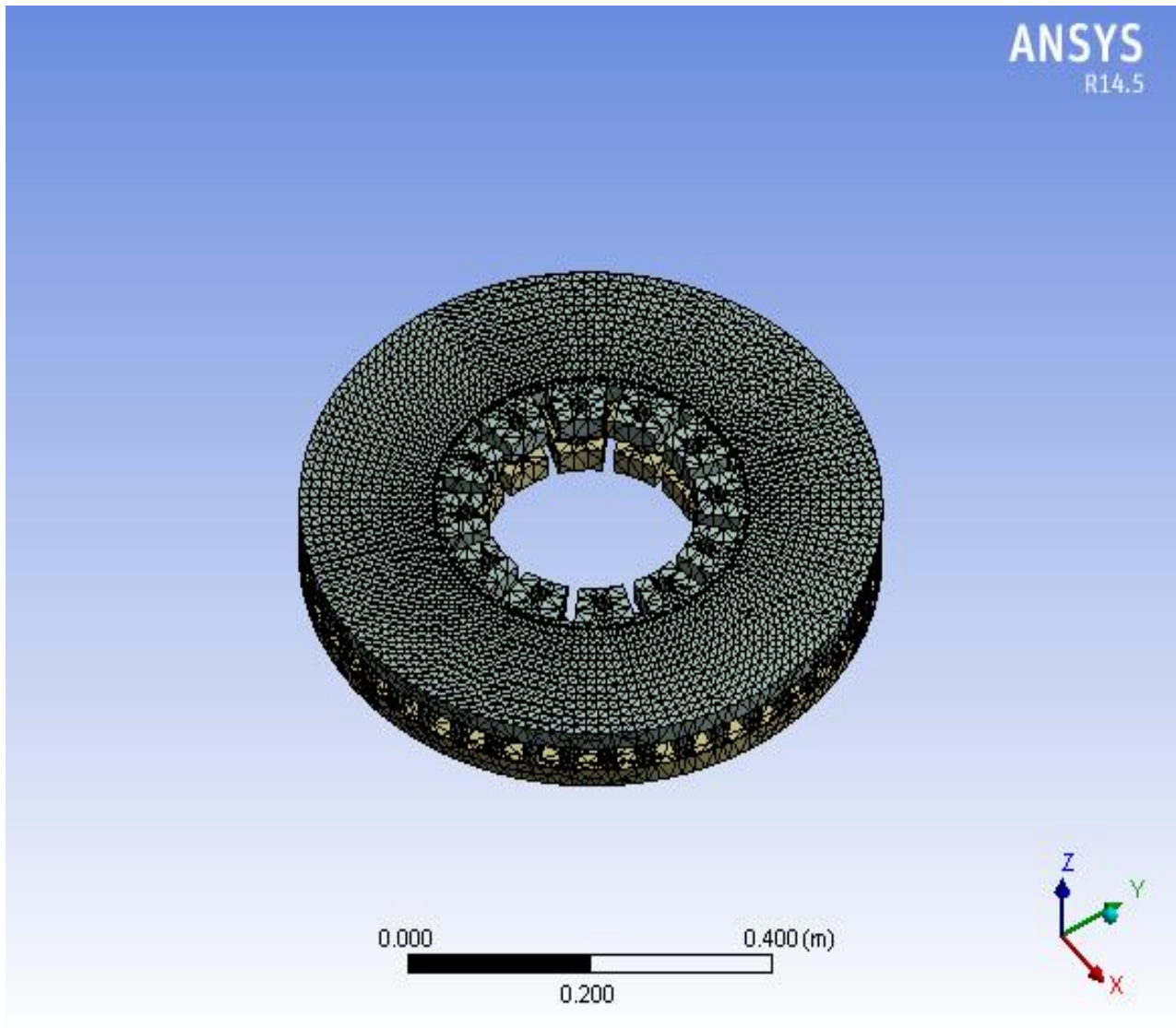

Figure 4.2a Meshed Model of ventilated Disc

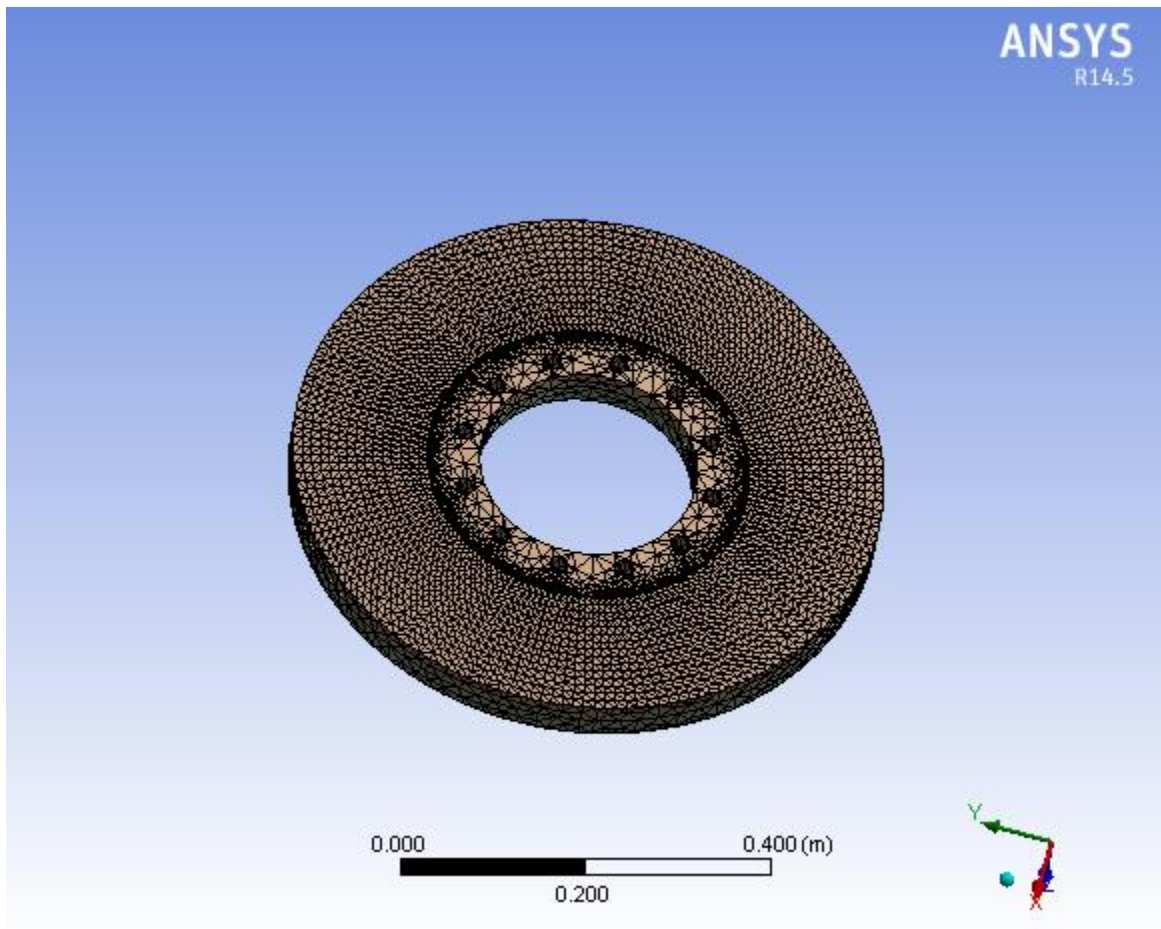

Figure 4.2b Meshed Model of solid Disc

4.4.5 DEFINITION OF THE LOADS AND BOUNDARY CONDITIONS

After completion of the finite element model, it was necessary to apply constraints and loads to the model. The analyzed railway disc brake is subjected to the following loads.

- The initial temperature of the disc is 40 °C.
- The surface convection condition is applied at all surfaces of the disc with the values of the convection coefficient (h) of 14.52 W/m².K for ventilated disc and 10.54 W/m².K for solid disc
- The heat flux into the brake disc during braking can be calculated before by the formula described in equation 3.17.
- The pressure on the rubbing contact surfaces of the disc and brake pad of value 1.1148Mpa.

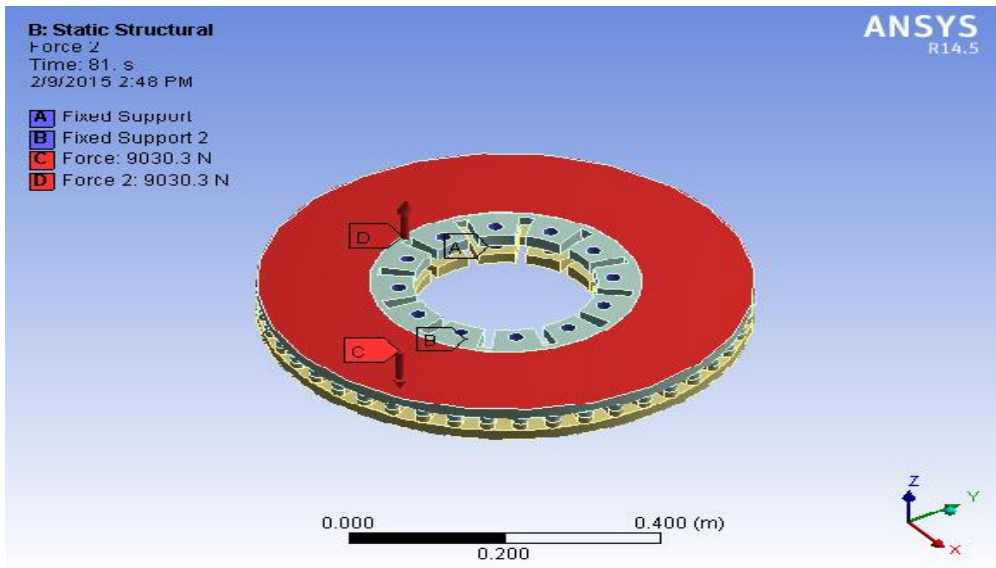

Figure 4.3a Force Acting on the Rubbing Surface of the ventilated Disc

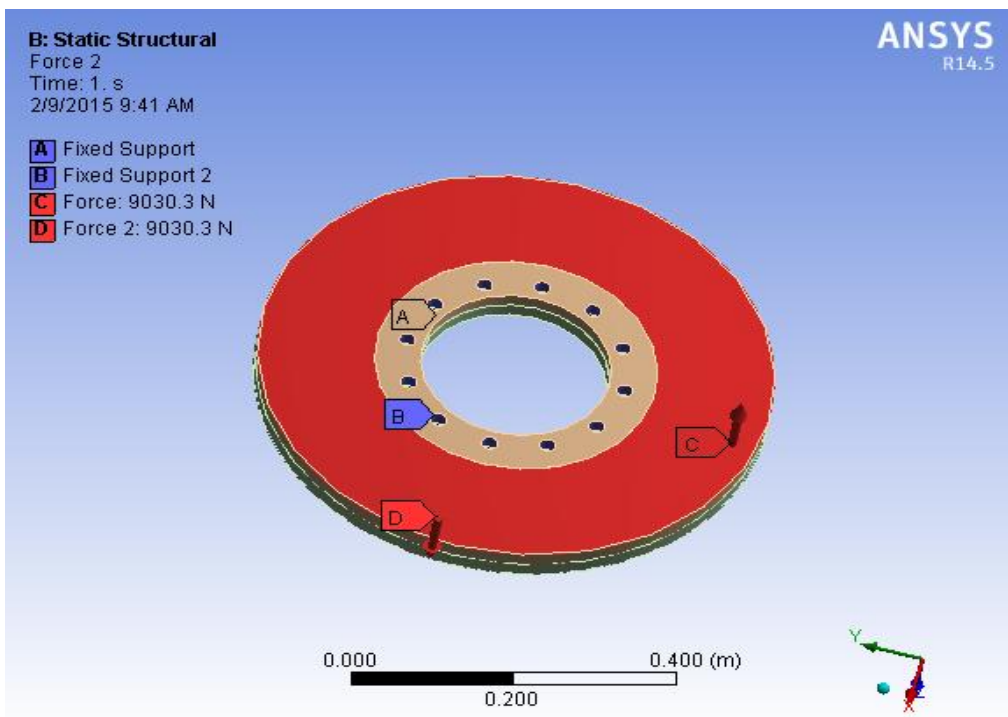

Figure 4.3b Force Acting on the Rubbing Surface of the solid Disc

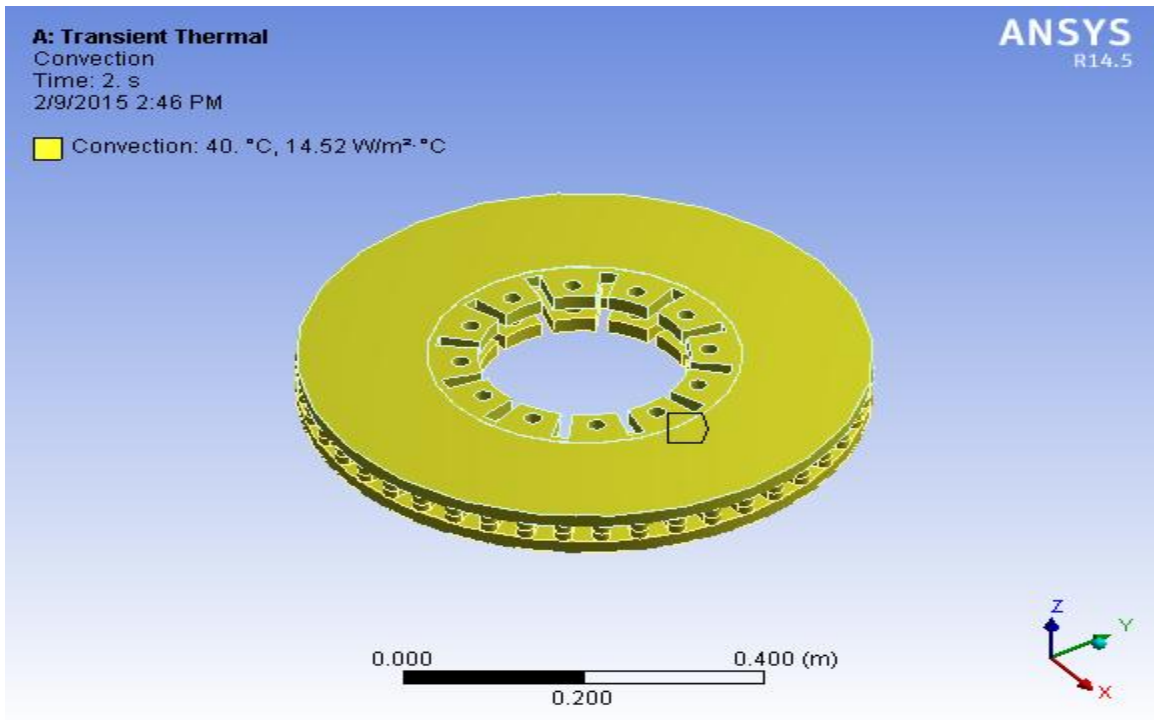

Figure 4.4a the Thermal Loading of Convection

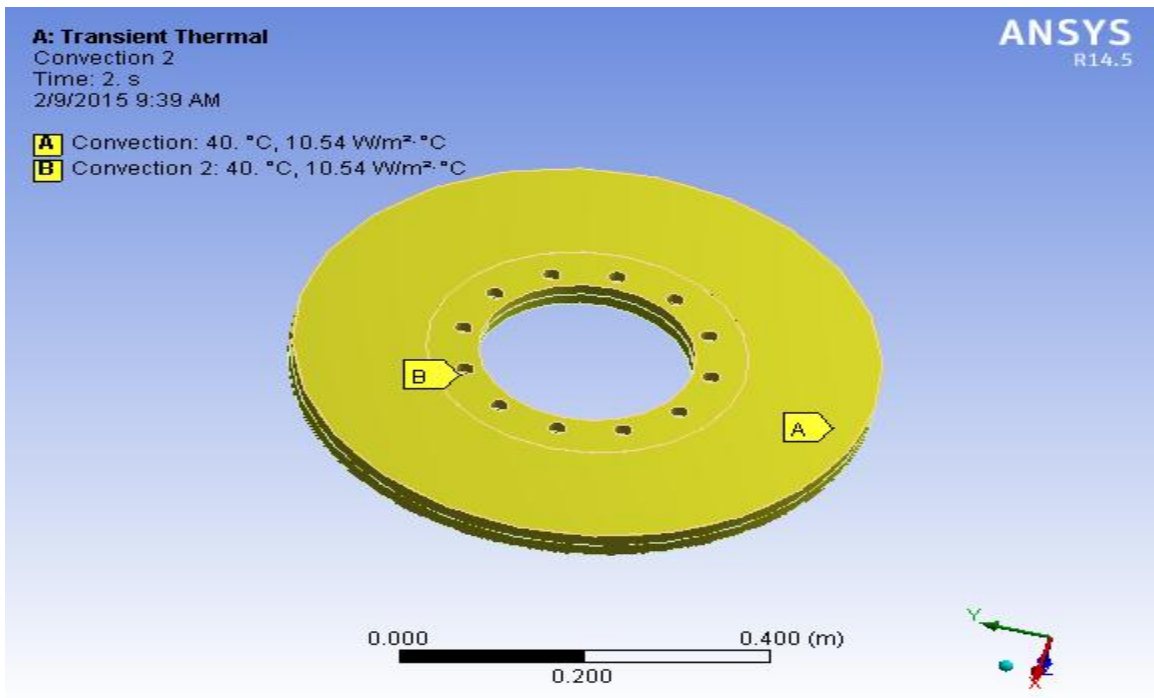

Figure 4.4b the Thermal Loading of Convection

CHAPTER FIVE

RESULT AND DISCUSSION

There are two ways to calculate the heat input at runtime heat analysis: one is that using the contact pressure acts on the disk and the rotational speed of the disk; the other is that using the change of the vehicle's kinetic energy. In the former case, it is necessary to calculate the contact pressure required for the non-linear contact analysis, in this study; we calculate the input values using the latter, which is a relatively simple case. It is assumed that the friction at the disk and pad during braking is transferred into heat energy and the heat flux was applied to areas of friction. Heat and heat flux necessary to perform thermal analysis are calculated from kinetic energy that occurs while driving the rail vehicle.

For the types of shape of a ventilated disc and solid disc models, by doing the unsteady thermal analysis for under three times repeated braking, the temperature that occurs on each disk was calculated. The maximum temperature, the temperature distribution and cooling performance occurred on the disk were analyzed. In addition, through the highest temperature and the temperature rise that occurred in ventilated disk for three times repeated braking, the process of temperature rise of the ventilated disk was analyzed. After the three times braking, the temperature at the solid disc was the highest; the vane at the ventilated disk can be seen that lowered the temperature.

To compare the cooling performance of each disk, after performing braking three times, the temperature of the disks was checked. The disc with vents shows a lower temperature than the solid disc; ventilated disc showed better cooling performance.

5.1 TEMPERATURE DISTRIBUTION OF BRAKE DISC

Braking generates an amount of friction heat makes the brake temperature rise sharply, and results in high local temperature, thermal degradation and thermal injury, and even damage. The speed of vehicle V_0 is 100km/h in this thesis. Figure 5.2 and 5.3 show the highest temperature over time in each disk. Temperature occurs from repeated braking in the disk; before the incoming heat into the disk at the previous step is discharged; heat which accumulated on the disk goes to the braking process again, like a stair climbing feature type. During deceleration of the braking cycle, the temperature of each disk is rapidly rising, and rapidly going down during cooling. As the temperature

of the disc continues to rise with braking, and the width of temperature rise in the deceleration appears to have no big changes, but the higher the temperature of the disk, the more the decrease of temperatures in acceleration.

When the locomotive is engaging braking, disc rotor is contacting brake pads. Due to the heat generation of the rubbing surface, a clear hot annular dispersed of heat accumulation is observed in the contact region. The temperature distribution can be observed in the figure 5.1.

The maximum temperature of brake disc is observed in the middle of the friction surface. The temperature decreases radial direction off from the mid contact area. However, high temperature area band is seen around the outer rim of the disc than inner bore.

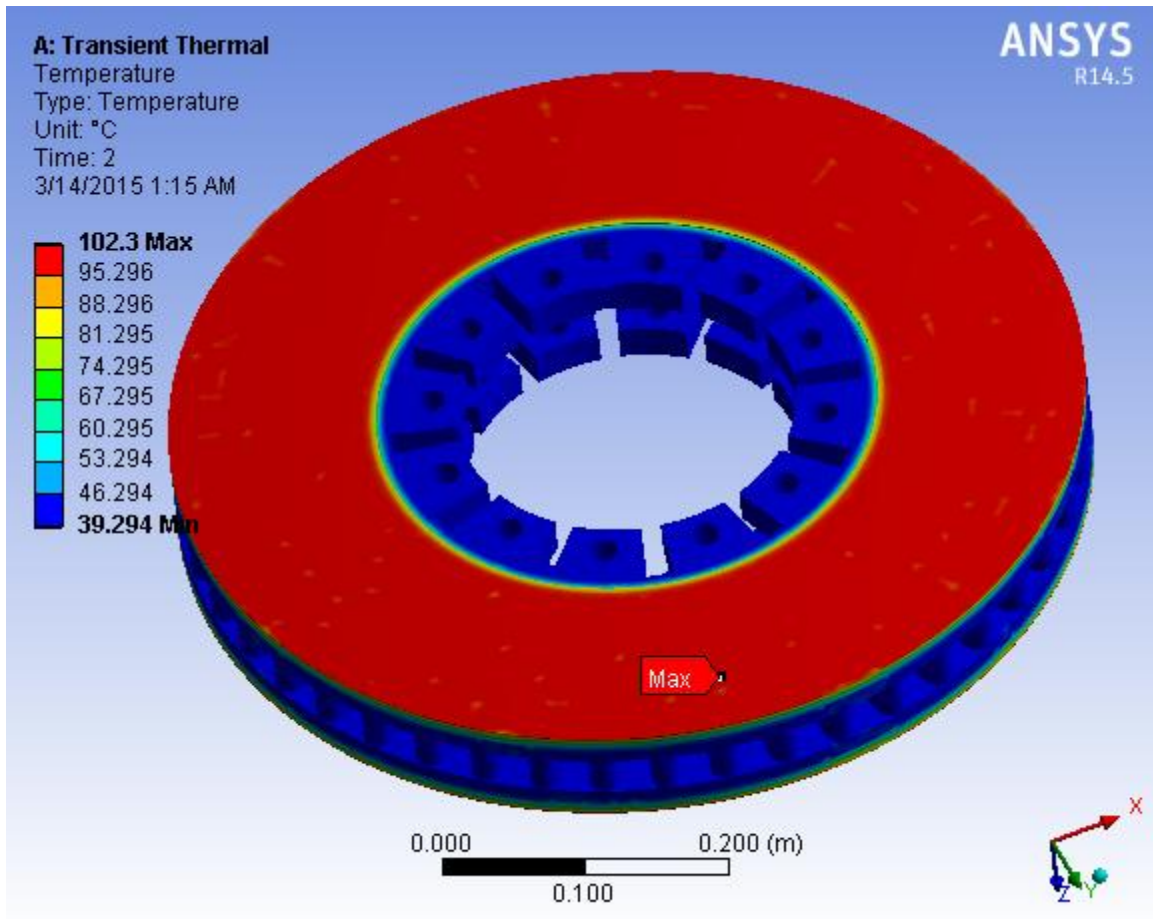

Figure 5.1 Temperature gradient in ventilated brake disc at 2s

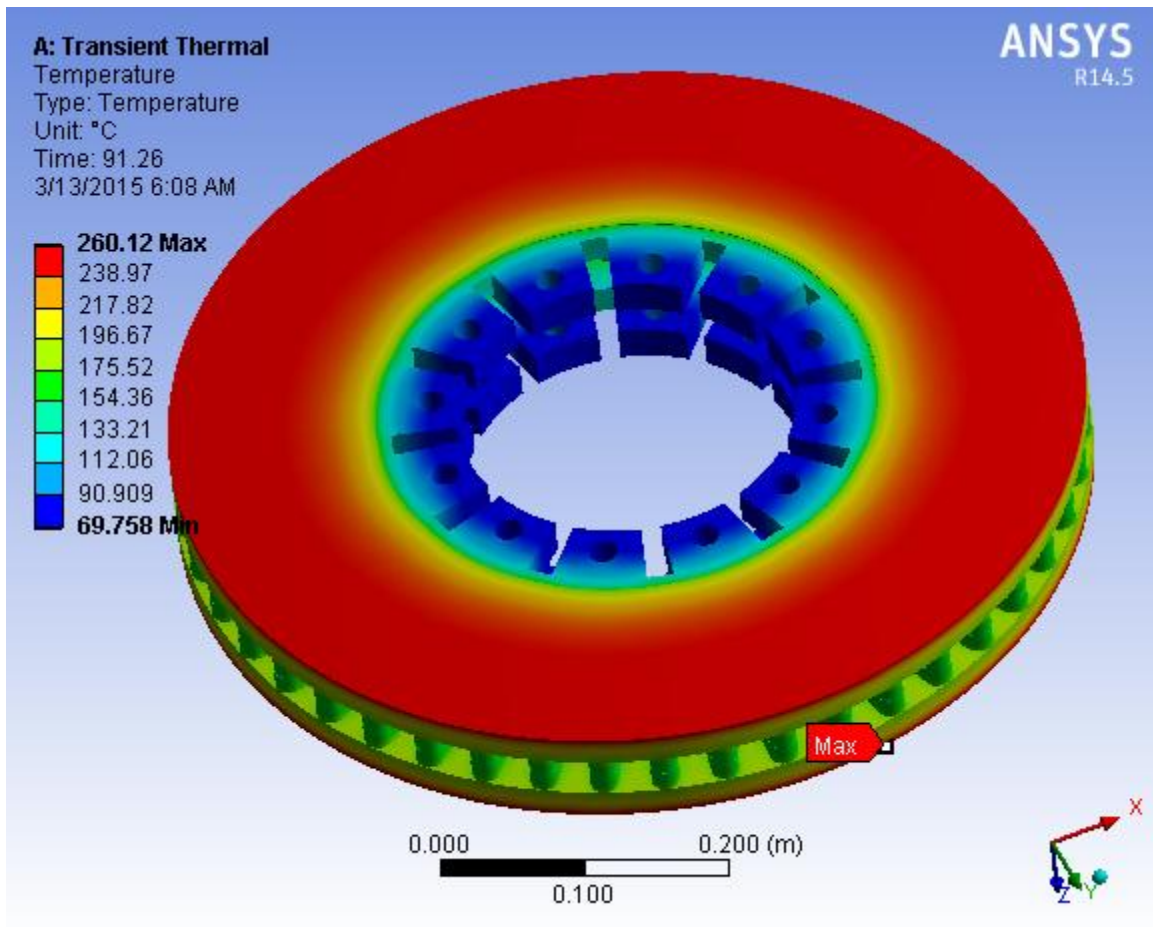

Figure 5.2 Temperature distributions in ventilated brake disc

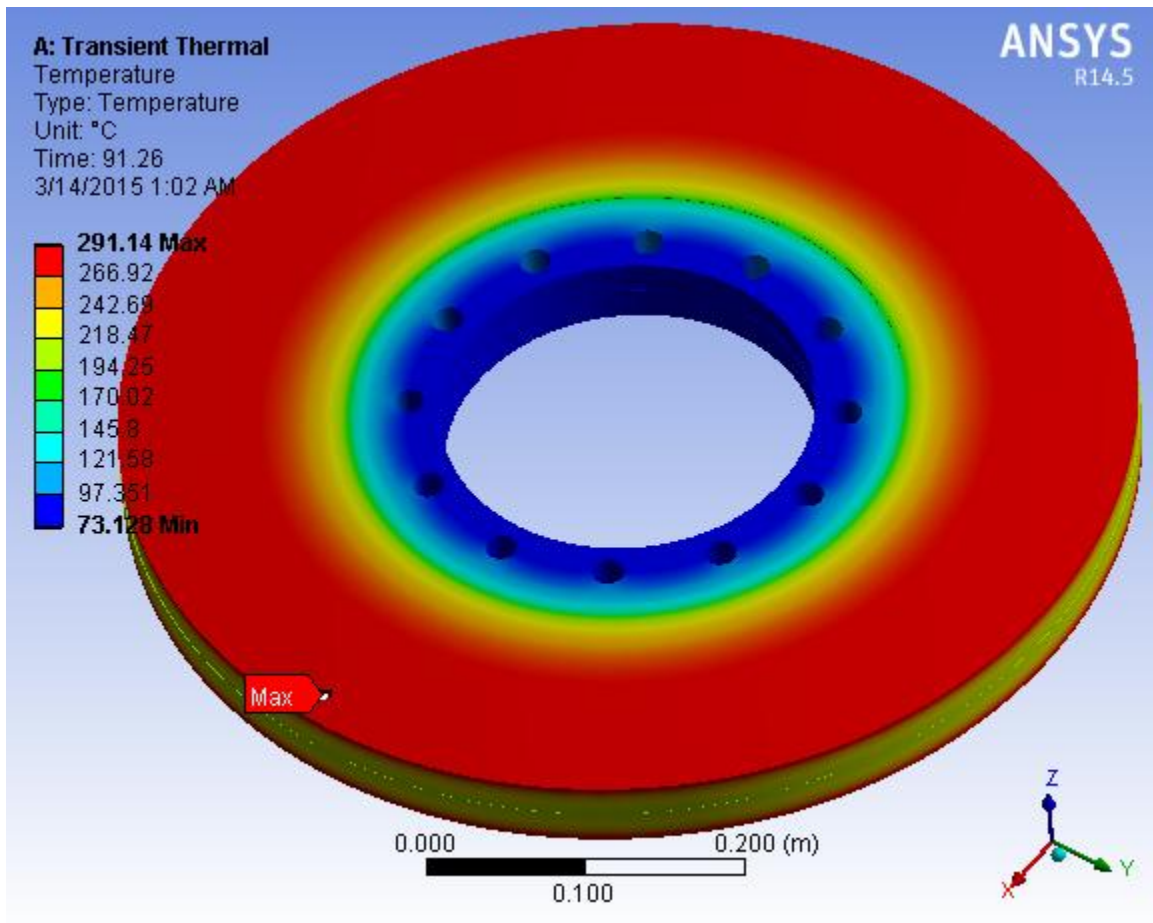

Figure 5.3 Temperature distributions in solid brake disc

5.2 THE DISTRIBUTION STATE OF TEMPERATURE RADIAL DIRECTION

The temperature of the nodes in the radial direction is as shown in Figure 5.4 and 5.5, resulting from the combined influence of the heat input into the rotor's surface and the heat convection, the overall trend show ascendant state. The friction heat on surface increases with the increasing of tangential velocity, the tangential velocity near the inner diameter is small, so the temperature near the inner diameter disc low and the temperature near the outside diameter is high. The high temperature mainly concentrates in the near surface edge of brake disc. The temperature of brake disc on surface increases with the increasing of radial size. The highest temperature at solid brake disc reaches to 291.14 °C, the temperature of inner edge reaches 73.13°C and that of ventilated disc brake was

260.12°C maximum temperature and 69.76°C minimum temperature. The temperature of nodes in the edge is slightly less than the maximum temperature because of convection between the edge and air.

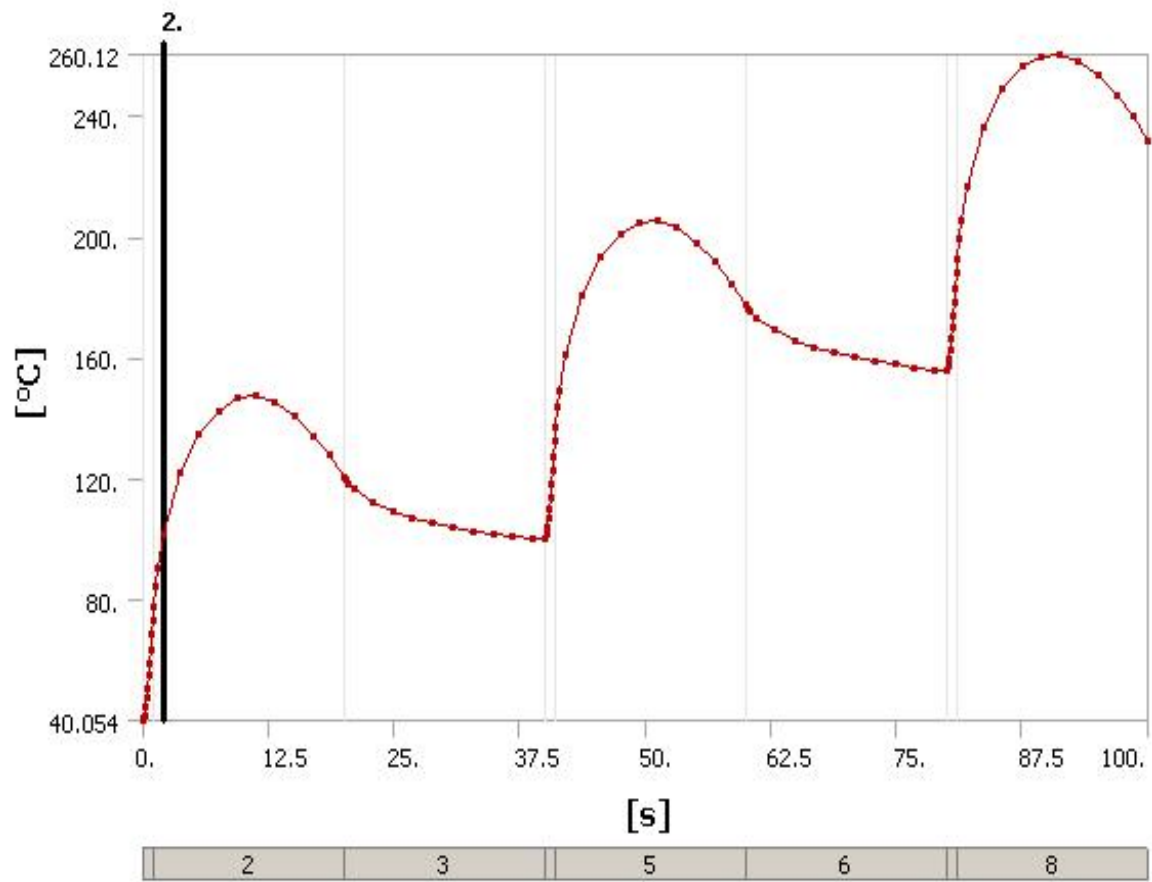

Figure 5.4 Temperature time curve in ventilated brake disc at 100s

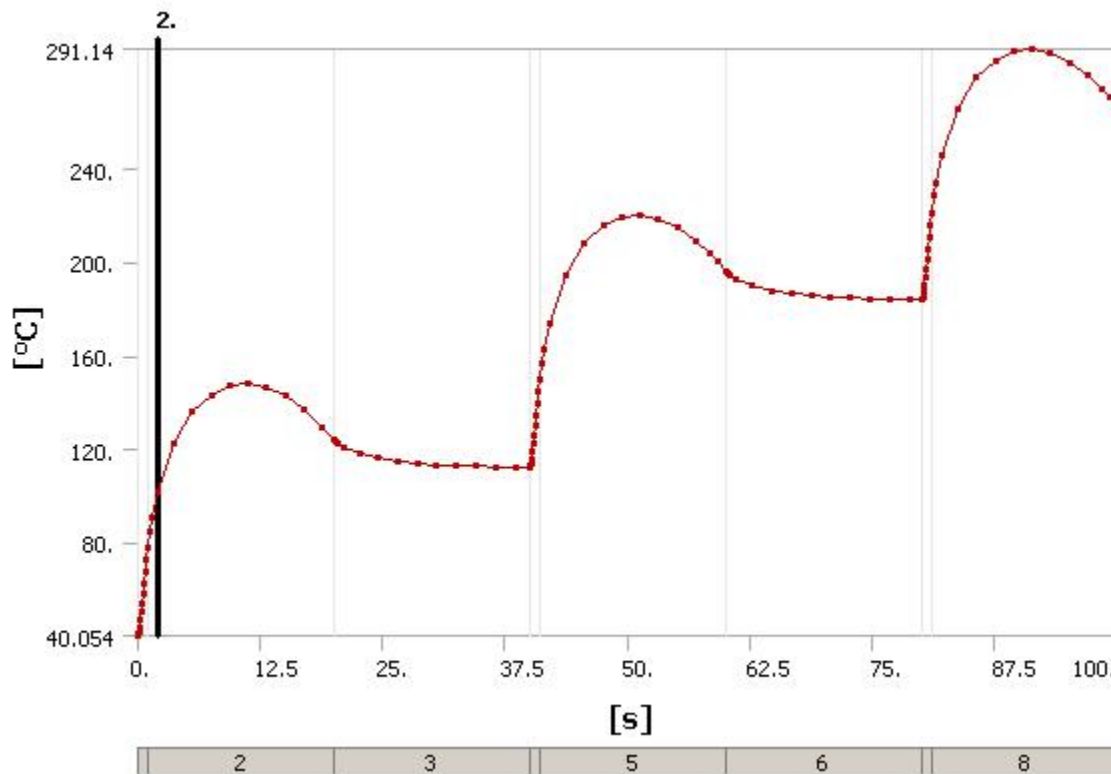

Figure 5.5 Temperature time curve in solid brake disc at 100s

5.4 THERMAL DEFORMATION

Graph 5.6a and Graph 5.6b gives the distribution of the total distortion in the whole disc for various moments of simulation. For this figure, the scale of values of the deformation varies from 0.01496mm to 0.399mm for ventilated disc brake and for solid disc brake 0.01399 to 0.491mm. The value of the maximum displacement recorded during this simulation is at the moment $t = 100$ s, which corresponds to the time of braking. One observes a strong distribution which increases with time on the friction tracks and the external crown and the cooling fin of the disc. Indeed, during a braking, the maximum temperature depends almost entirely on the heat storage capacity of disc (on particular tracks of friction); this deformation will generate a symmetry of the disc following the rise of temperature which will cause a deformation in the shape of an umbrella.

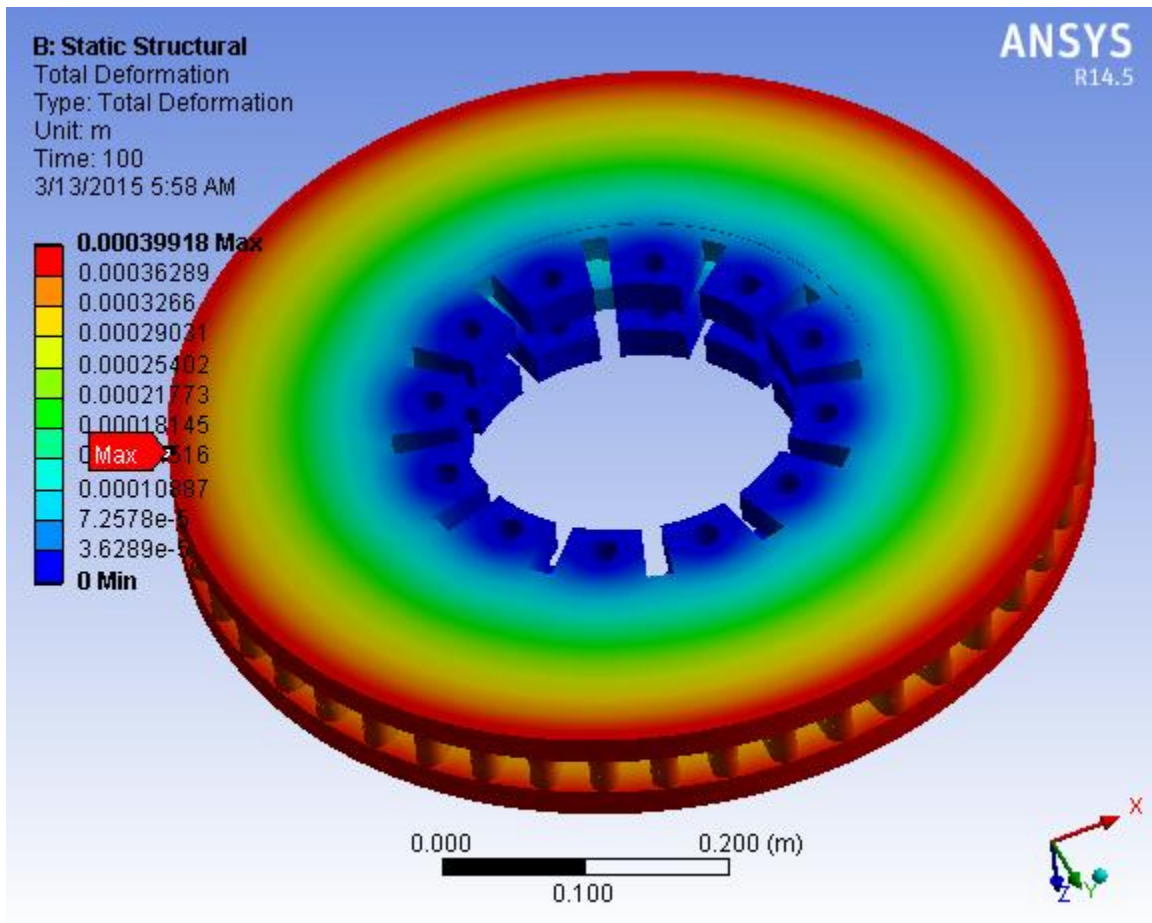
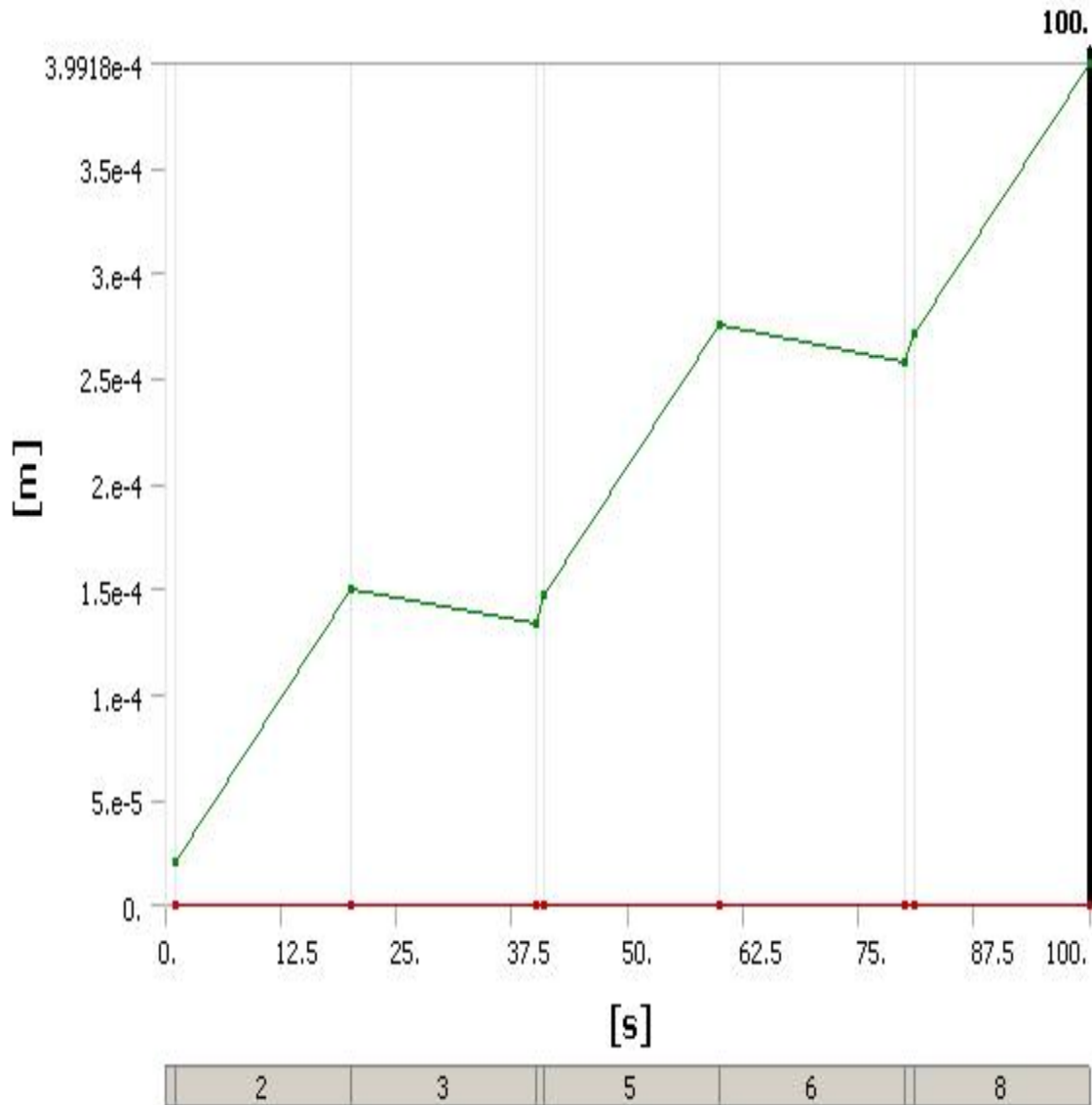

Figure 5.6a Total deformations in ventilated disc brake



Graph 5.6a Total deformations in ventilated disc brake

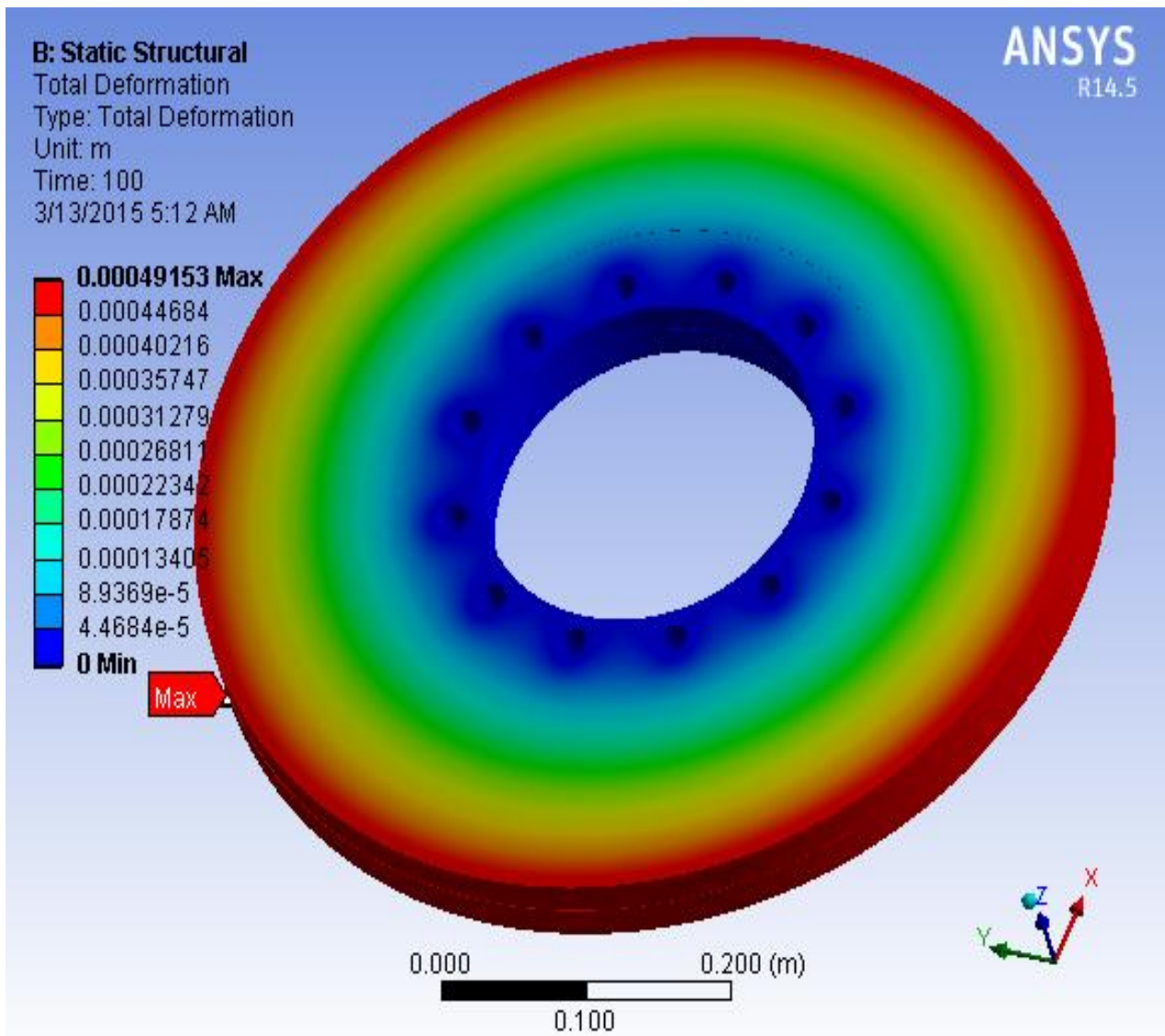
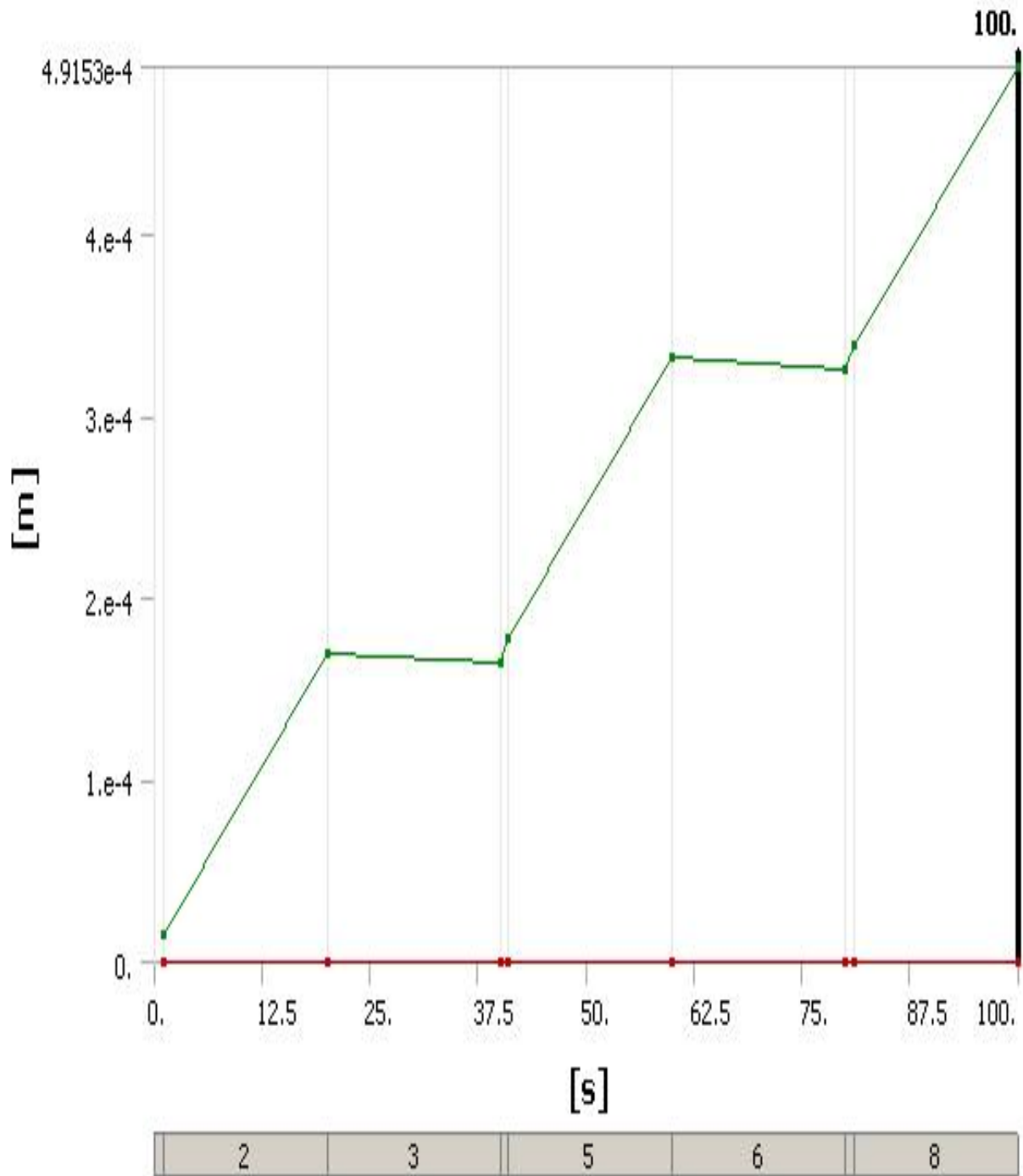

Figure 5.6b Total deformations in solid disc brake



Graph 5.6b Total deformations in solid disc brake

5.5 VON MISES STRESS DISTRIBUTION

Graph 5.7a and 5.7b present the distribution of the constraint equivalent of Von Mises stress 1s to 100s second, and the scale of values at ventilated disc brake varies from 50 MPa to 289.08 MPa and for solid disc, we have the value from 50 MPa to 378 MPa . The maximum value recorded during this simulation of the thermomechanical coupling is very significant compared to that obtained with the assistance in the mechanical analysis under the same conditions. One observes a strong constraint on the level of the bowl of the disc. Indeed, the disc is fixed to the hub of the wheel by screws preventing its movement.

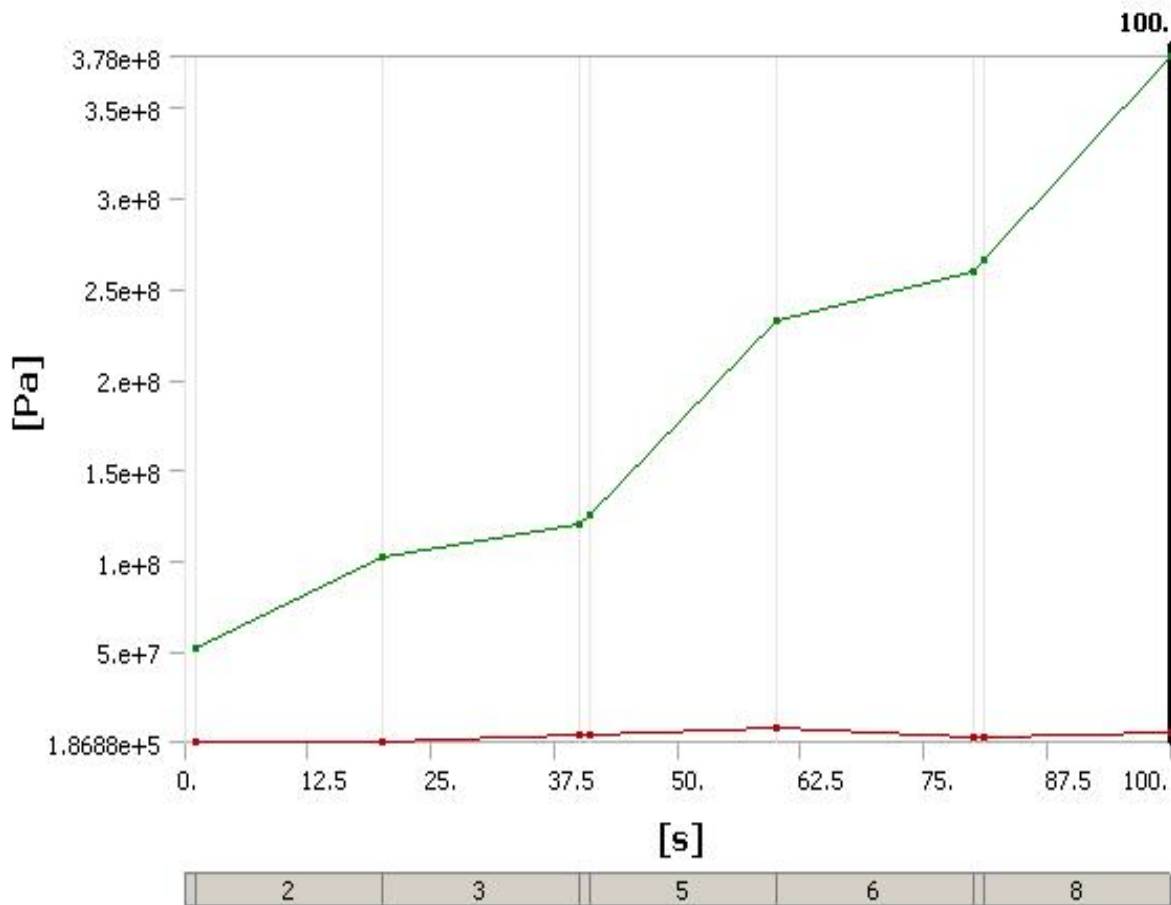

Graph 5.7a Equivalent von mises stress in solid disc brake

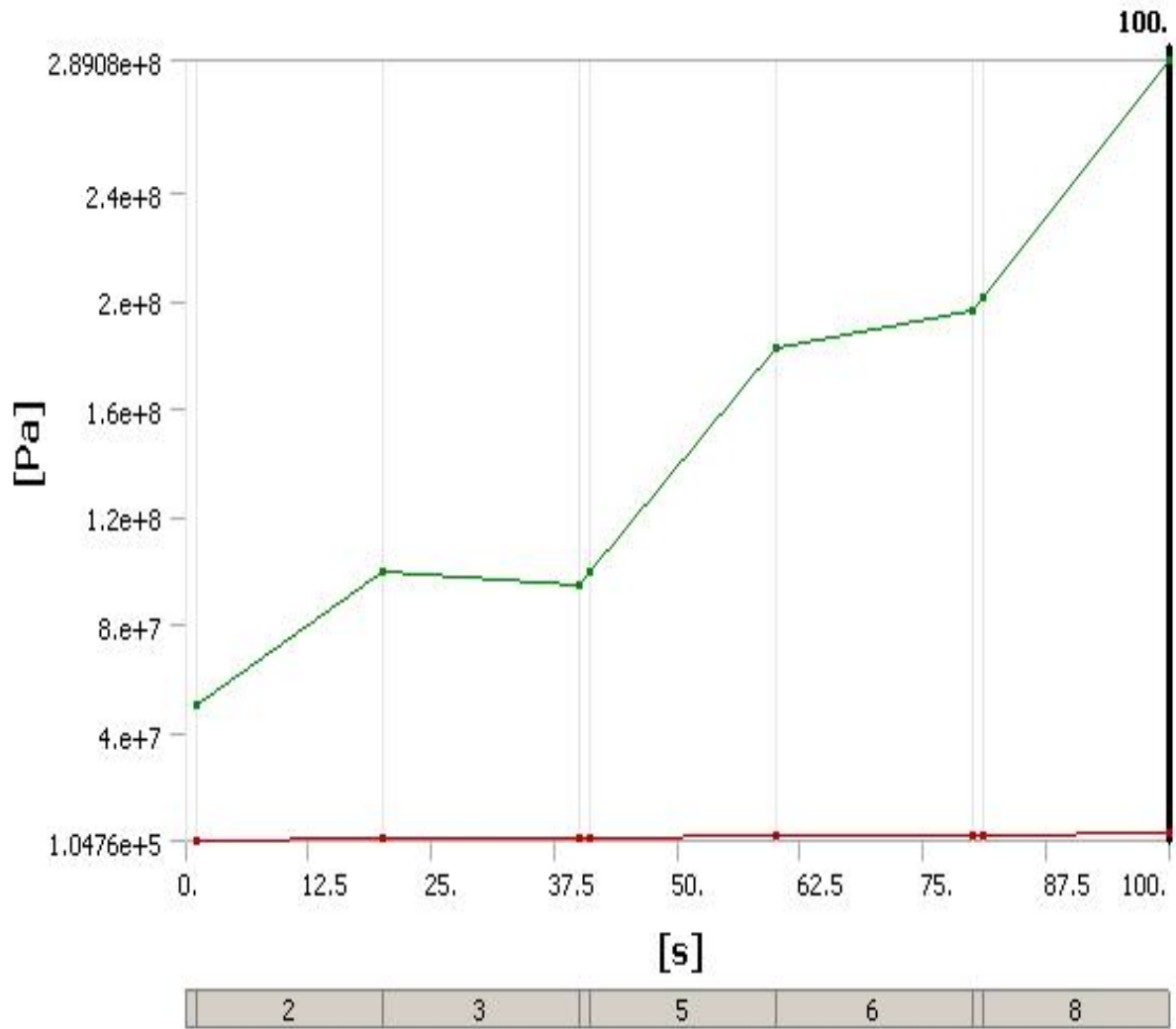

Graph 5.7b Equivalent von mises stress in ventilated disc brake

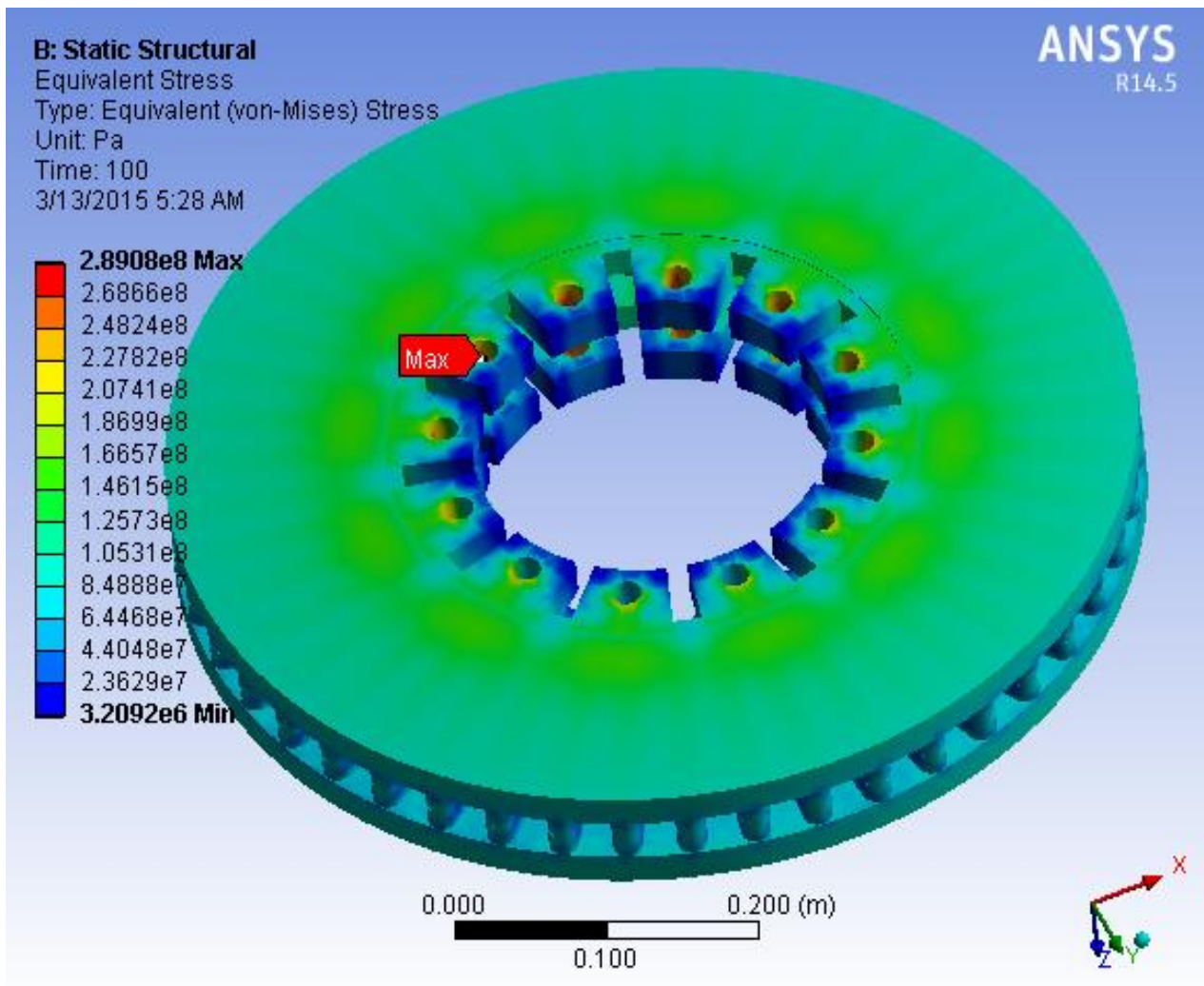

Figure 5.7 Equivalent von mises stress in ventilated disc brake

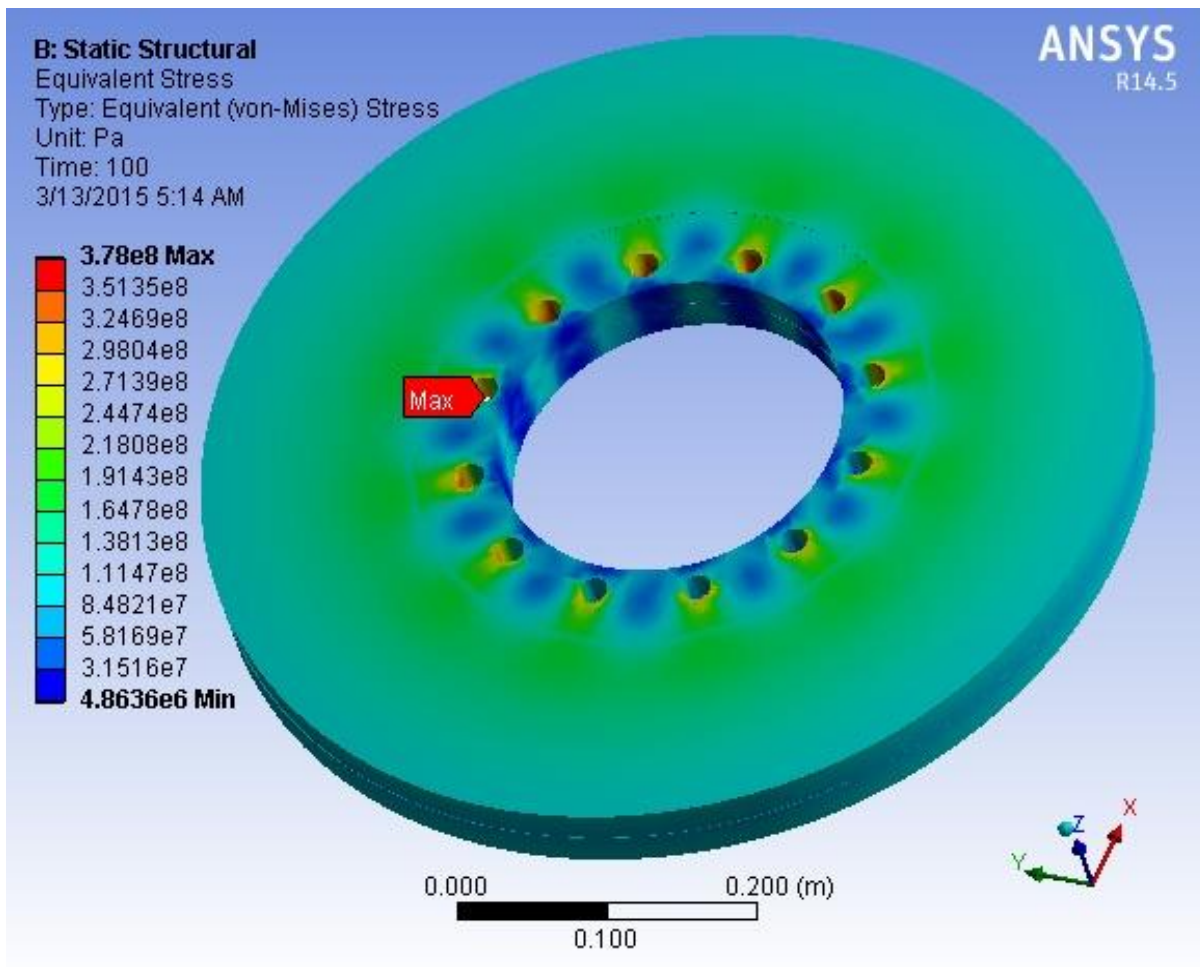

Figure 5.8 Equivalent von mises stress in solid disc brake

5.6 TOTAL HEAT FLUX

In addition figures 5.9 and 5.10 also show that the total heat flux entered in to the brake disc through the contact region of the disc slightly disperses to the surfaces in radial direction in a diminishing fashion.

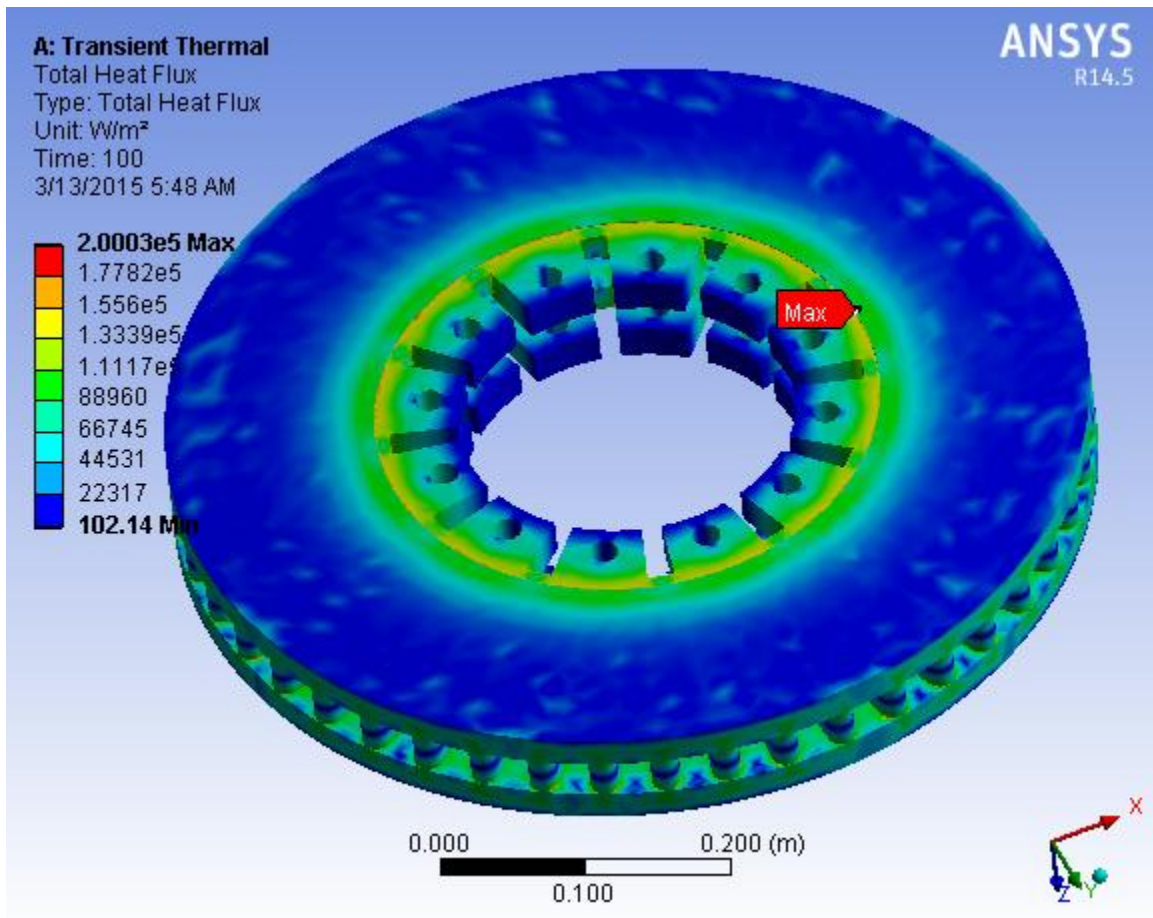

Figure 5.9 Total heat flux in ventilated disc brake

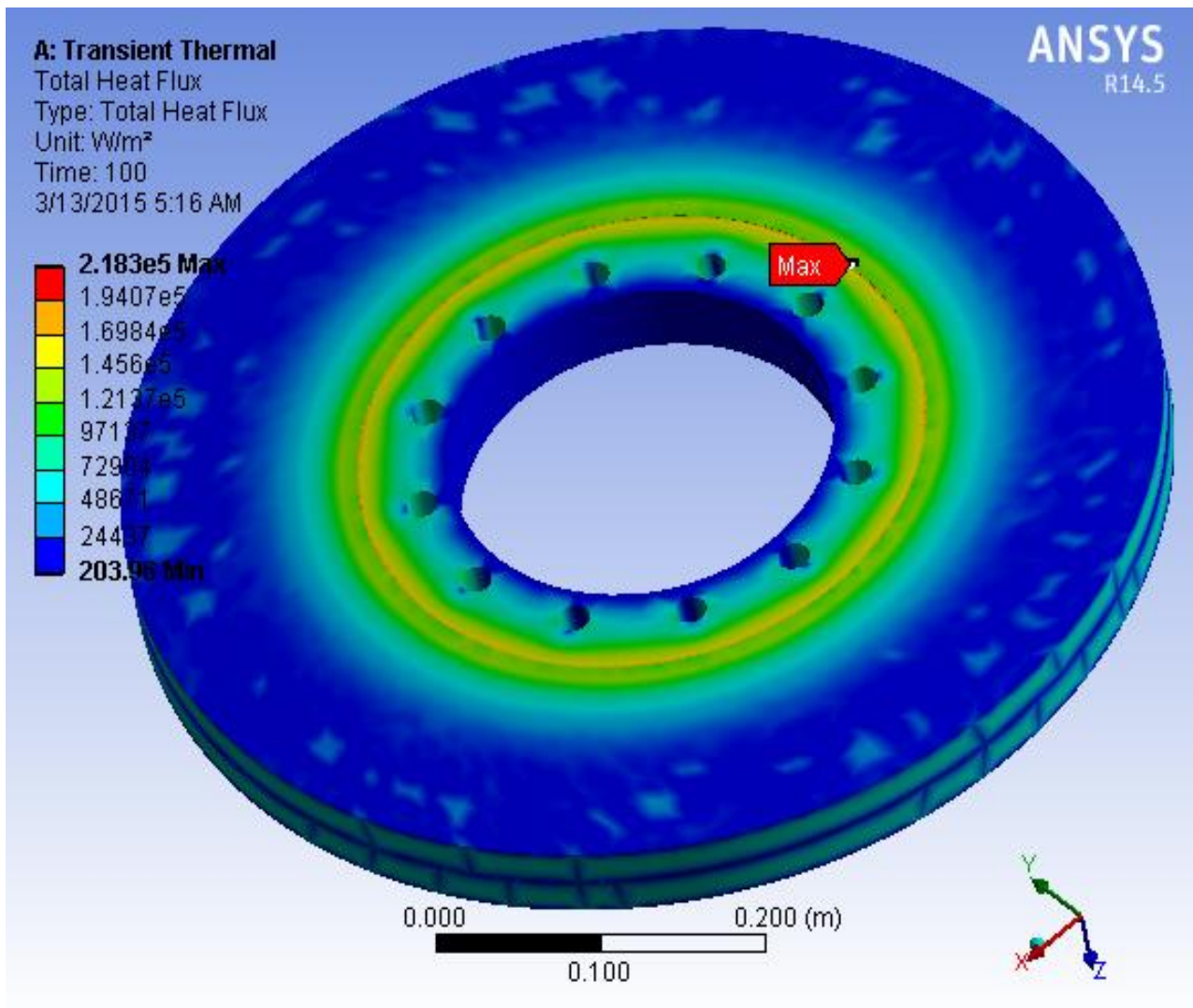

Figure 5.10 Total heat flux in solid disc brake

5.6 REPEATED BRAKING

During vehicle operating, the braking system is subjected to repeated actions of the driver. In this study, we considered two types of disc brake of which the total simulation time is estimated to be equal to 100 s. Figure 5.11 shows a driving cycle of three successive braking, in the form of saw tooth without ideal braking and it is best to implement practically to ERC locomotive in ideal braking without any failure. We note that the temperatures in the disc rise firmly with each application of brake, then begin exponential decline. The more the number of repetitions of braking increases, the more the maximum temperatures increase. The initial state of the disc changes after each cycle, the downtimes allow only one partial cooling. After each cooling phase, the disc begins to warm again. In fact, during successive braking the capacity of cooling of the disc is insufficient to lower the surface temperature to near the initial temperature, which causes an accumulation of energy and therefore a higher surface temperature. These results show that the transient thermal behavior of a disc brake depends on the braking cycle imposed and it is dominating because it dictates the cooling time of the disc.

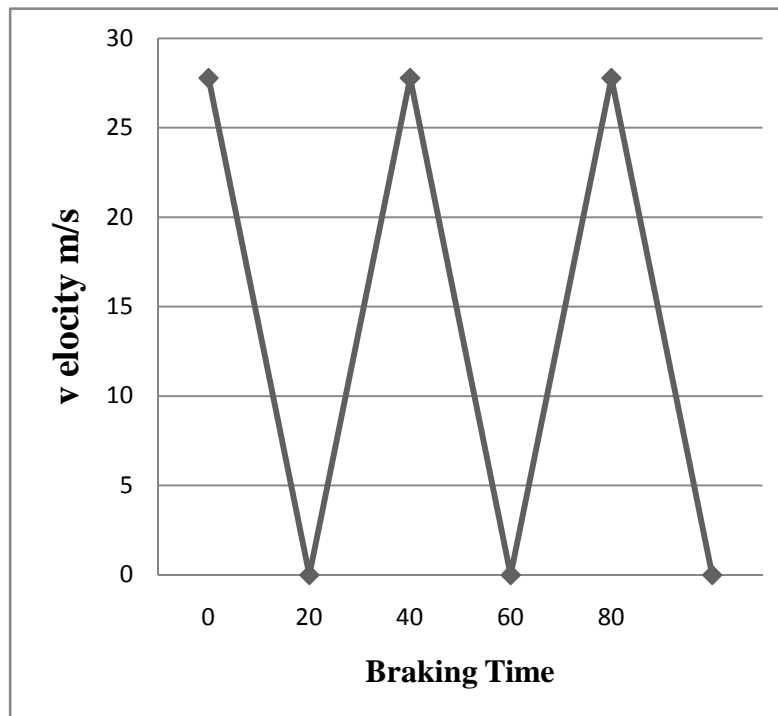

Figure 5.11 repeated brake application

CHAPTER FIVE

CONCLUSION AND RECOMMEDATION

5.1 CONCLUSION

Through finite element analysis for ventilated disk and solid disk, thermal deformation analysis and thermal stress analysis due to heat transfer were carried out in order to analyze the thermo- stress characteristics of disc brakes. By comparing the maximum temperature in the braking process, the ventilated disk showed a lower temperature than the solid disk and the effect of temperature increase and decrease, depending on the vent area generated in the disk. During the cooling process, the maximum temperature of the ventilated disks decreased, based on the increase of heat dissipation area due to the vent, and as little as 31.02°C , even as much as 10.65 percent, decreased depending on the wetted area of the vent, compared with that of solid disks. The thermal deformation in ventilated disc type occurs in all directions by 0.399 mm; Stresses caused by heat were focused on the mounting area (hub parts section) and. In addition to the influence of the ventilation of the disc, we also studied the influence of repeated braking on the thermal behavior of the discs brake. The numerical simulation shows that radial ventilation plays a very significant role in cooling of the disc in the braking phase. Generally, the results of temperature rise, deflection, and stress field obtained from analysis it shows that in the ventilated disc brake reduction in temperature, stresses and deformation by 10.65 % , 30.79% and 23% respectively than the solid disc. It is concluded that ventilated type disk brake is the best for the present application. All the values obtained from the analysis are less than their allowable values. Hence the brake disk design is safe based on the strength and rigidity criteria.

5.2 RECOMMENDATION

From this study, we look that to increase the heat transfer from the brake discs and to reduce the disc surface temperature on the total surface area of the brake discs, the heat transfer coefficients are gradually increased by employing ventilation applications. The obtained results are very useful for the study of the thermomechanical behaviour of the disc brake. The disc brake is recommended to use for Djibouti to Addis Ababa railway transport vehicles for Ethiopian Railway Corporation.

6. FUTURE STUDY

- The comparison with experimental results and consideration of more precise contact condition between and disc and pad should be analyzed.
- The application for other materials of disc brakes should be considered.
- The fatigue behavior of the brake disc cast iron material should be investigated over a range of cyclic brake application.
- Investigation of thermo-structural behavior for high speed trains.

7. REFERENCE

- [1] UNECA."Africa Review Report on Transport," United Nations Economic and Social Council 27-30, Addis Ababa, Ethiopia, October 2009.
- [2] Yehualaeshet Jemere,"Addis Ababa Light Rail Transit Project'" July, 2012.
- [3] P. Dufrenoy, Two-/three-dimensional hybrid model of the thermomechanical behavior of disc brakes, Proc. IMechE Part F: J. Rail Rapid Transit. 218 (2004) 17-30.
- [4] Kim SJ, Jang H. Friction and wear of friction materials containing two different phenolic resins reinforced with aramid pulp. TribolInt 2000;33:477–84.
- [5] Jacko MG, Rhee SK. Brake linings and clutch facings. Kirk – Othmerencyclopedia of chemical technology, 4th ed., 4. New York: Wiley; 1992.
- [6] Jacko MG, Tsang PHS, Rhee SK. Wear 1984;100:503–15.
- [7] Cho MH, Kim SJ, Kim D, Jang H. Effects of ingredients on tribological characteristics of a brake lining: an experimental case study. Wear2005; 258:1682–7.
- [8] J. H. Choi, I. Lee, Finite Element Analysis of Transient Thermoelastic Behaviors in Disk Brakes, Science Direct, Wear 257 (2004) 47-58.
- [9] C.H. Gao and X.Z.Lin, Transient Temperature Field Analysis of a Brake in a Non-axisymmetric Three-Dimensional Model, Journal of Materials Processing Technology 129 (2002) 513-517.
- [10] D. G. Grieve, D. C. Barton, D. A. Crolla, J. T. Buckingham, Design of a lightweight Automotive Brake Disc Using Finite Element and Taguchi Techniques, Institution of Mechanical Engineers; 1998; 212, 4; ProQuest Science Journal.
- [11] Latif M. Jiji, Heat Convection, Berlin ; New York : Springer, c2006
- [12] Johnson D. A, B. A. Sperandei, R. Gilbert, Analysis of the Flow Through a Vented Automotive Brake Rotor, Journal of Fluids Engineering, ASME, Nov. 2003, Vol. 125/979
- [13] R. Limpert, Cooling Analysis of Disc Brake Rotors, SAE paper 751014, 1975.
- [14] A. D. Mcphee and D. A. Johnson, Experimental Heat Transfer and Flow Analysis of a Vented Braked Brake Rotor, International Journal of Thermal Sciences, Vol. 3, No. 6, 2007.
- [15] T. P. Newcomb and R. T. Spurr. Braking of road vehicles London : Chapman and Hall, 1967.
- [16] D. Parish and D. G. MacManus, Aerodynamic Investigations of Ventilated Brake Discs, the Inatitution of Mechanical Engineers, Wilson Applied Science & Technology Abstracts, Vol. 4, pp 219, 2005..

- [17] Dipl.-Ing. C. Repmann, Volkswagen AG, Wolfsburg, Investigation of the Thermal Behavior of Vented Disc Brakes By Means of CFD, SAE 2005 World Congress, Detroit, Michigan, 2005.
- [18] H. Sakamoto, Heat Convection and Design of Brake Discs, institution of Mechanical Engineering; Sep 2004; 218,3; Wilson Applied Science & Technology Abstracts. Pg. 203
- [19] Dufre'noy P (2004) Two-/three-dimensional hybrid model of the thermomechanical behavior of disc brakes. *J Rail Rapid Transit Part F* 218:17–30.
- [20] Zhongzhe Chi., Thermal Performance Analysis and Geometrical Optimization of Automotive Brake Rotors, M.S Thesis, University of Ontario Institute of Technology, Oshawa,Canada,2008.
- [21] David,A., Bryan, A.,Ross,G.,Analysis of the flow through a vented automotive brake rotor, *Journal of Fluids Engineering*, 125(2003),01, pp 979-986.
- [22] Voller,G. P., Tirovic,M., Morris,R.,Gibbens,P., Analysis of automotive disc brake cooling characteristics, *Journal of Automobile Engineering*, 217(2003),Part D, pp 657-666.
- [23] Arthur Stephens., Simon Watkins.,Chris Dixon., Aerodynamic Testing of a Vented Disc Brake, *Journal of SAE*,0932(2003),01,pp6-8.
- [24] Anders Jerhamre.,Christer Bergstrom.,Numerical study of brake disc cooling accounting for both aerodynamic drag force and cooling efficiency, *Journal of SAE*,0948(2001),01,pp 3-5.
- [25] Manohar Reddy,S.,Mallikarjuna,J.M.,Ganesan,V., Flow and Heat Transfer Analysis of a Ventilated Disc Brake Rotor Using CFD, *Journal of SAE*, 0822(2008),01,pp 1-12.
- [26] Amol,A.,Ravi,R.,FE Prediction of Thermal Performance and Stresses in a Disc Brake System, *Journal of SAE* ,2572(2008),01,pp 5-8.
- [27] Blot, B., '*Computation of a thermally stressed brake disc*', SAE Technical Paper Series: 890086,1989.
- [28] Ali Belhocine, Mostefa Bouchetara, Simulation of fully coupled thermo-mechanical analysis of disc brake rotor, University of Sciences and the Technology of Oran L.P 1505 El -Mnaouer, USTO 31000 Oran ALGERIA
- [29] Ali Belhocine and Mostefa Bouchetara, Thermal- mechanical coupled analysis of a brake disc rotor, University of Sciences and the Technology of Oran, L.P 1505 El -MNAOUER, USTO 31000 ORAN (Algeria)

- [30] B. Ghadimi , F. Kowsary and M. Khorami, Thermal analysis of locomotive wheel-mounted brake disc, *Applied Thermal Engineering* 51 (2013) 948-952
- [31] Daudi, A. R., Dickerson, W. E. and Narain, M., '*Hayes' Increased Airflow Rotor Design'*, *Automotive Braking: Recent Developments and Future Trends*, Barton, D. C. and Haigh, M. J., Eds, PEP, UK, 1998
- [32] McPhee D.A and D.A Johnson, Experimental heat transfer and flow analysis of a vented brake rotor *International journal of thermal science*, 47, 2007, 458-467
- [33] Ch. Zuber and B. Heidenreich, Development of a net shape manufacturing method for ventilated brake discs in single piece design, *Materialwissenschaft und Werkstofftechnik*, 37 (4) (2006) 301-308.
- [34] D. B. Antanaitis and A. Rifici, The effect of rotor crossdrilling on brake performance (2006) *SAE*, 2006-01-0691, 571-596.
- [35] D. Aleksendric, C. Duboka, P. F. Gotowicki, G. V. Mariotti and V. Nigrelli, Braking procedure analysis of a pegs-wing ventilated disk brake rotor, *International Journal of Vehicle System Modelling and Testing* (2006) 1, 4, 233-252.
- [36] G. Venkitachalam and M. Maharudrappa, Flow and heat transfer analysis of a ventilated disc brake rotor using CFD, *SAE*, 2008-01-0822 (2008).
- [37] S. B. Park, K. S. Lee and D. H. Lee, An investigation of local heat transfer characteristics in a ventilated disc brake with helically fluted surface, *Journal of Mechanical Science and Technology*, 21 (2007) 2178-2187.
- [38] Y. Yildiz and M. Duzgun, Stress analysis of ventilated brake discs with finite element method, *International Journal of Automotive Technology*, 11 (1) (2010) 133-138.
- [39] D. J. Kim, Y. M. Lee, J. S. Park and C. S. Seok, Thermal stress analysis for a disk brake of railway vehicles with consideration of the pressure distribution on a frictional surface, *Materials Science and Engineering A* (2008) 483-484, 456-459.
- [40] F. Bagnoli, F. Dolce and M. Bernabei, Thermal fatigue cracks of fire fighting vehicles gray iron brake discs, *Engineering Failure Analysis*, 16 (1) (2009) 152-163.
- [41] P. Hwang and X. Wu, Investigation of temperature and thermal stress in ventilated disc brake based on 3D thermomechanical coupling model, *Journal of Mechanical Science and Technology*, 24 (2010) 81-84.

- [42] T. J. Mackin et al., Thermal cracking in disc brakes, *Engineering Failure Analysis*, 9 (2002) 63-76.
- [43] T. K. Kao, J. W. Richmond and A. Douarre, Brake disc hot spotting and thermal judder: an experimental and finite element study, *International Journal of Vehicle Design*, 23 (3/4) (2000) 276-296.
- [44] Tirovic, M. and Day, A. J., '*Disc brake interface pressure distributions*', Proc. Instn Mech Engrs Vol. 205, pp 137-146, 1991
- [45] <http://www.csrgc.com.cn>
- [46] Marko Reibenschuh, Grega Oder, Franci Šuš, Iztok Potr : Modeling and Analysis of Thermal and Stress Loads in Train Disc Brakes – Braking from 250 km/h to Standstill, University of Maribor, Faculty of Mechanical Engineering, Slovenia
- [47] UIC 541-3, Brakes — Disc brakes and disc brake pads — General conditions governing bench tests
- [48] Khong Keng Leng, AM34: Simulation of Temperature Distribution in Brake Discs, National University of Singapore 2007/2008.
- [49] Akara Sawardsuk, Saiprasit Koetnियom, Design and Development of Thai Railway Brake Disc under Temperature Analysis, *International Journal of Engineering Science and Innovative Technology*, Volume 2, Issue 1, January 2013
- [50] Miloš S. Milošević , Dušan S. Stamenković , Andrija P. Milojević , and Miša M. TOMIĆ , modeling thermal effects in braking systems of railway vehicles, Faculty of Mechanical Engineering, University of Niš, Niš, Serbia.
- [52] <http://www.railways.skf.com>
- [53] <http://www.siemens.com>
- [54] <http://www.railelectrica.com>
- [55] Jiguang Chen and Fei Gao, Thermo-Mechanical Simulation of Brake Disc Frictional Character by Moment of Inertia, Dalian Jiaotong University, Liaoning, 116028, China
- [56] J.M. Coulson and J.F. Richardson, *Chemical Engineering*, vol. 1, eq.9.88; material properties from appendix A2.
- [57] R. Limpert, *Brake design and safety*, Second Edition, Society of Automotive Engineers, Inc. Warrendale USA (1999) 140-143.