



Addis Ababa University
School of Graduate Studies
Faculty of Computer and Mathematical Science
Department of Computer Science

Design and Implementation of Mobile Based Patient Follow-up System

By Daniel Abebe Negash

A Project paper submitted to the School of Graduate Studies of Addis Ababa University in partial fulfillment of the requirements for the Degree of Master of Science in Computer Science

August 2011

Addis Ababa University
School of Graduate Studies
Faculty of Computer and Mathematical Science
Department of Computer Science

Design and Implementation of Mobile Based Patient
Follow-Up System

By Daniel Abebe Negash

Advisor: Dr. Solomon Atnafu

Members of the Examining Board:

1. Dr. Solomon Atnafu, Adviser

2. Dr. Dida Midekso, Examiner

Acknowledgments

I would like to thank GOD for giving me strength to complete this project. I am also grateful to my advisor Dr. Solomon Atnafu for his motivative and constructive guidance as of the beginning of problem formulation to the completion of the project. My sincere gratitude also goes to Computer Science department staff and my classmates for their cooperation and encouragement in the course of my graduate study.

I would like to forward my special thanks to St. Paul's General Specialized Hospital for giving me chance to collect data for my project and to conduct open interview. I would also like to thank Mr. Eric Winkler, Sana mobile team leader, for his response to my queries.

Finally, I would like to extend my thanks to my parents for their encouragement, motivation and support throughout my study.

Table of Contents

1. INTRODUCTION.....	1
1.1. BACKGROUND	1
1.2. MOTIVATION.....	3
1.3. STATEMENT OF THE PROBLEM.....	4
1.4. OBJECTIVE.....	5
1.4.1. GENERAL OBJECTIVE	5
1.4.2. SPECIFIC OBJECTIVES.....	5
1.5. SCOPE	5
1.6. METHODOLOGY	6
1.7. ORGANIZATION OF THE DOCUMENT	6
1.8. APPLICATION OF THE RESULT	6
2. LITERATURE REVIEW	7
2.1. MOBILE PHONE TECHNOLOGY IN HEALTH APPLICATION.....	7
2.2. SMS and MMS HEALTH APPLICATIONS.....	7
2.3. ODK and SANA MOBILE HEALTH APPLICATIONS.....	10
3. SYSTEM ANALYSIS.....	13
3.1. CURRENT PATIENT FOLLOW-UP SYSTEM.....	13
3.2. PROPOSED PATIENT FOLLOW-UP SYSTEM	14
3.2.1. Overview	14
3.2.2. Functional Requirements.....	14
3.2.3. Non-Functional Requirements	15
4. SYSTEM MODEL	18
4.1. USE CASE	18
4.2. CLASS DIAGRAM	27
4.3. SEQUENCE DIAGRAM.....	28
5. SYSTEM DESIGN.....	41
5.1. DESIGN GOALS	41
5.2. PROPOSED SYSTEM MODEL.....	42
5.2.1. System Architecture	42
5.2.2. System Decomposition.....	43

5.2.3. Persistent Data Management	45
6. IMPLEMENTATION.....	46
6.1. DEVELOPMENT ENVIRONMENT.....	46
6.2. THE PROTOTYPE.....	47
6.2.1. Mobile Phone Application.....	47
6.2.2. Diagnose Web Application.....	51
6.3. TESTING	53
7. CONCLUSION.....	54
REFERENCE:.....	56
APPENDIX.....	59

List of Tables

Table 4.1: System actors' descriptions.....	18
Table 4.2: Use Case Descriptions.....	20

List of Figures

Figure 4.1: Use case diagram.....	19
Figure 4.2: Class Diagram.....	27
Figure 4.3: Form download sequence diagram.....	28
Figure 4.4: Fill form sequence diagram	29
Figure 4.5: Edit form sequence diagram	30
Figure 4.6: Upload form sequence diagram	31
Figure 4.7: Read Result sequence diagram	32
Figure 4.8: Delete form sequence diagram	33
Figure 4.9: Send result sequence diagram	34
Figure 4.10: Login sequence diagram	35
Figure 4.11: Logout sequence diagram	36
Figure 4.12: Change password sequence diagram	37
Figure 4.13: Add new user sequence diagram	38
Figure 4.14: Edit user sequence diagram	39
Figure 4.15: Delete user sequence diagram	40
Figure 5.1: System Architecture	42
Figure 5.2: Subsystem Decomposition	43
Figure 5.3: Deployment Diagram	44
Figure 5.4: System Relational Model	45
Figure 6.1: Main menu	47
Figure 6.2: Application starter	48
Figure 6.3: Setting	48
Figure 6.4: Follow up using video procedure	50
Figure 6.5: Login	51
Figure 6.7: Patients' follow-up request queues	51
Figure 6.8: Diagnosis patient's follow-up request	52
Figure 6.9: Received diagnosis result	52

List of Acronyms

ICT	Information Communication Technology
GSM	Global System for Mobile Communication
TB	Tuberculosis
ARV	Antiretroviral
PMTCT	Many Prevention of Mother to Child Transmission
HIV	Human Immunodeficiency Virus
SMS	Short Message Service
AIDS	Acquired Immune Deficiency Syndrome
GPS	Global Positioning System
GPRS	General Packet Radio Service
WiFi	Wireless Fidelity
MMS	Multimedia Messaging Service
GIS	Geographic Information System
SIM	Subscriber Identity Module
ODK	Open Data Kit
PDA	Personal Digital Assistant
OpenMRS	Open Medical Record System
m-Health	Mobile Health
RAM	Random Access Memory

Abstract

Healthcare organizations are required to give prompt services and follow-up for patients. They rely on data and information for every aspect of their delivery. Huge amounts of data are generated in a mostly unstructured paper environment and this leads them to give low quality healthcare service. Today, it is hard to imagine healthcare without Information and Communication Technology (ICT). ICT has a capacity to transform the health industry and the way it manages its data, information and knowledge as well as to revolutionize the way in which clinicians work.

Mobile phone usage and communication offers an effective means of bringing healthcare services for developing countries. The penetration of mobile phone networks globally leads several millions of citizens that never had regular access to fixed-line telephone or a computer. Nowadays mobile devices are highly regarded as daily tools for communication and data transfer. This growing ubiquity of mobile phones is a central element in the promise of mobile technologies for health.

This project design and implement a Mobile Based Patient Follow-up System using Amharic and English language. It provides continual follow-up for out-patients and prevents them from traveling long distance for follow-up from resource-poor environments. It also creates an opportunity for health professionals and patients to stay in contact. In addition, it can be used as a tool to increase the level of support and information available to patients and health workers. These positive changes can result in reduced hospitalization rates as well as a decrease in the number of days spent in hospital.

Keywords: Patient Follow-up, Mobile Based Patient Follow-up

1. INTRODUCTION

1.1. BACKGROUND

Healthcare quality, cost and patient safety are adversely affected and compromised by the current largely paper-based system in Ethiopia. It is necessary to advise a solution that helps solve such demoralizing problem. Information technology has been proposed in this regards as an essential tool for addressing the problem of fragmented and inaccessible clinical information. Information technology such as electronic health records, e-prescribing, clinical decision support systems, electronic management of chronic disease, and bar coding of drugs and biological products have been proposed to be employed as workable means to reduce health care costs and improve patient safety.

Nowadays, efficiency, cost-effectiveness, quality, and safety of medical care delivery in the healthcare system are improved through ICT application and promises. The realization of these benefits is especially important in the context of reports that show five years of consecutive annual double-digit increases in healthcare costs and rising the number of adverse health effects in the world [1]. Reports have also suggested that still investments in healthcare industries are inefficient processes. Representatives of organizations and leaders at the federal and state levels have emphasized the need for healthcare to follow the example of many non-healthcare industries, in which the implementation of computer information technology has been critical and employed for increasing accessibility of mission-critical information, automating labor-intensive and inefficient processes, and minimizing human error.

Mobile phone usage and service coverage improve healthcare services even in remote and less resourced settings. Mobile communication offers an effective means of bringing healthcare services to developing countries. The penetration of mobile phone networks globally enables thousands and millions of citizens, who never had regular access to fixed-line telephone or a computer, use mobile devices as daily tools for communication and data transfer. 64% of all mobile subscribers are found in the developing world. Furthermore, estimates show that by 2012, half of all individuals in remote areas of the world will have mobile phones [2]. This growing ubiquity of mobile phones is a central element in the promise of mobile technologies for health.

Research shows that mobile technology improves the efficiency of health care delivery, and ultimately makes healthcare service more effective[3,4]. Current mobile technology promise shows that mobile health technology will have demonstrable and significantly positive impact on clinical outcomes such as reduced infant mortality, longer life spans and decreased contraction of disease [5,6,7]. In Ethiopia, fixed-line Internet connections are rare. But GSM mobile signal coverage has reached to 64% of the total land area of the country [8]. This would enhance the possibility of increasing the efficiency and effectiveness of delivery of outpatient healthcare and decrease the substantial financial losses for healthcare systems. Moreover, it precisely uses clinical and administrative staff and results in reducing waiting times for other patients.

Here, managing long-term chronic condition using mobile phone health system is the best solution. That is, treating chronic diseases needs a long-term communication with the patient and imposes additional burden on the health system specifically as it needs to maintain a patient's history and monitor his/her progress. One approach to manage chronic care is to give patients a small notebook or card, "a health passport," for their records. As long as it is not lost or damaged (an important risk), this can solve the first problem by having history of the patient's care. The weakness is that it does not support the monitoring and close watch of patient care. It puts the load on patients to take their treatment and to return for follow-up visits. Not only must the patient remember the date, find and pay for transport, and arrange child care, but the patient must also understand the importance of the treatment and its plan. Particular at-risk groups are patients with HIV, partially treated tuberculosis (TB), or other chronic diseases who are asymptomatic and may not have the capacity to fulfill these requirements. Over 20% of patients on antiretroviral (ARV) treatment have missed appointments [9] or lost to follow-up [10] in 1 year in some major HIV projects in Africa, with one study reporting 59% loss to follow-up over 4 years [11]. Many prevention of mother to child transmission (PMTCT) programs report very high loss to follow-up, with losses of more than 80% recorded in South Africa [12]. This approach put strong challenge for chronic condition patients. Likewise, there is no any system in Ethiopia which has proposed to give solution and support for such patients.

This project gives a solution for the above challenges, that is, it is a mobile based system that provides continual follow-up about treatment status for out-patients and helps keep records of critical data such as laboratory tests and medication. And given the barriers that can prevent a patient from returning for follow-up in resource-poor environments [13,14,15] and the frequent need for migration due to poverty and social disruption. Moreover, the system helps find missing patients and provide treatment. Failure to do so for HIV and TB is often a serious situation. An essential component of the system is a master patient list, regularly follow-up and used to find missing or failing patients. Moreover, the system can be used by any healthy centers in Ethiopia to follow-up their patient especially for chronic disease patients.

1.2. MOTIVATION

Mobile phones are one of the fastest spreading technologies in the world and they are now being used by far more than just making calls. Like SMS, or text messaging, users are adopting the devices – and the technology – to completely familiarize them with new ends never envisaged. With an estimated 2.2 billion mobile phone users in the developing world (64% of the global market) mobile phone technology presents a great opportunity and potential to address and positively impact the many health challenges facing resource-poor countries [2]. This motivated us to undertake a perfect work to develop a mobile phone based health system.

1.3. STATEMENT OF THE PROBLEM

As there are more senior citizens and patients with chronic diseases in Ethiopia, the number of people who need constant assistance increases. Also, patients that are being discharged from hospitals and often require additional healthcare services including health status follow-up. Nevertheless, the current scenery depicts the long patient and operation waiting lists, shortages of hospital beds, community care and inadequate medical facilities and professionals to provide patients with intensive care in emergency units and other healthcare departments. This leads to:

- a healthcare system that doesn't support the monitoring and close watch of patient care
- put the burden on patients to make their treatment and to return for follow-up visits
- find and pay for transport
- high costs involving the conventional internment
- Moreover, in Ethiopia there is no system that gives solution to these problems and to follow-up patients using mobile phone.

1.4. OBJECTIVE

1.4.1. GENERAL OBJECTIVE

The general objective of this project is to design and implement a mobile based patient follow-up system.

1.4.2. SPECIFIC OBJECTIVES

Specific objectives of the project include:

- Review related systems and conduct literature review.
- Identify the data which needs to be collected and identify the functional and non-functional requirements of the system.
- Design the system based on the identified requirements.
- Develop a prototype to demonstrate the validity of the proposed design
- Test the developed prototype against its requirements

1.5. SCOPE

The system to be developed considers the patients that are discharged from hospitals and to follow up their daily healthy status and to monitor them through their mobile phone with their respective location (including GPS coordinates). On the server side, the system manages any communication between health worker and patients, and gives privilege to diagnosis and access followed-up information. However, the system to be developed:

- Doesn't consider in-patient follow-up and treatment activities.
- Only works for android mobile phone.
- Only uses GPRS and WiFi network
- Only considers Amharic and English Languages

1.6. METHODOLOGY

Different methodologies are used at the various phases of this project. The major activities are the following:

- Conduct literature review- resources including books, research reports, journal articles and written document
- Data collection through interview and questionnaire - different health workers and patients participated in identifying patient follow-up requirements.
- Identification and analysis of system requirements
- System design and object design
- Implementation is done using appropriate programming languages, emulators and other software tools.
- Testing to verify if the system meets its requirements.

1.7. ORGANIZATION OF THE DOCUMENT

This project document is organized into six Chapters including this one. The second Chapter presents literature review and related works. In the third and fourth Chapters, the current system analysis and design are presented. In the fifth and sixth Chapters, system implementation and testing are presented. Finally, in seventh chapter conclusion is presented.

1.8. APPLICATION OF THE RESULT

The application of the project can be used by medical doctors to follow-up and monitor their patients status after giving treatment and it can be used by patients to communicate with their doctors and to submit and know their healthy status. Moreover, it maintains and support text, image, audio and GPS coordinate data formats that help to exchange different forms of information for both patients and medical doctors.

2. LITERATURE REVIEW

2.1. MOBILE PHONE TECHNOLOGY IN HEALTH APPLICATION

Mobile phones usage has increased rapidly and they have become more affordable and available to most of the population. This availability creates a potential to revolutionize health care communication and improve health services. Before the emergence of mobile phone, communication means like fixed telephone help patients to remember for chronic medication [16]. Mobile phones application can now be used to provide appointment reminders, create treatment adherence systems, record patient diaries, conduct risk assessments, provide information and even conduct research.

Most of the above applications are implemented on SMS and MMS technologies for sending data. However, these technologies have limitations like: limited character size and don't support media including audio, video [17]. Whereas, ODK framework and Sana Open Source are new technologies and used GPRS, SMS and WiFi mobile Internet network for sending and receiving data using mobile phones. Moreover, this new technology uses Google's open source Android platform and scalable App Engine web service. It also allows capturing, submission, storing and reporting data in the form of text, video, audio, images, and GPS

2.2. SMS and MMS HEALTH APPLICATIONS

Frontline SMS: Medic

FrontlineSMS: Medic is an SMS based healthcare delivery system. It supports health workers communication, coordinates patient care, and provides diagnostics using low-cost, appropriate technology. The SMS network brought the Home-Based Care unit to the homes of 130 patients who would not have otherwise received care, and it saves 21 antiretroviral therapy (ART) monitors 900 hours of travel time, eliminates the need to hand deliver paper reports. However, this SMS based application is more limited to user interface flexibility and put into practice using simple text information and short forms. In addition, it is not used for patient follow-up and patients don't interact with the application, and it does not support requirements with larger forms more questions and a variety of data types (i.e., GPS, photos, audio, video, etc.) [18].

TRACnet

TRACnet is a system designed to collect, store, retrieve, and disseminate critical program, drug, and patient information related to HIV/AIDS care and treatment using mobile phone. It has a central repository of HIV/AIDS program information and delivers real-time information for decision-making. The system has transformed a largely paper-based one-way information flow that took several weeks, into a bidirectional data exchange completed in seconds. It allows decision-makers and supervisors to quickly analyze and respond to program information. However, TRACnet is a proprietary application only supported text data format (SMS), and not used for patient follow-up and patients can't interact with it [19].

San Diego Project SHARE

The project provide a way to monitor data submitted in real time through a web based interface, including a map-based view of data using GIS (geographic information system) and mobile phone. Due to its communication features, it is easy to reach individual health workers, send broadcast voice mail, e-mail, and SMS alerts to groups, post the latest health guidance, and host conference calls. When predefined trigger events are reported, the system generates emergency notifications via e-mail, voicemail, pager and SMS text messages. In the project, only officials and healthy works can participate and it doesn't support video message notification [20].

Mobile Telemedicine System for Home Care and Patient Monitoring

As stated in [21], a mobile telemedicine system is used for home care and patient monitoring. The system takes advantage of the serial port available in new mobile phones to implement a generic interface for patient monitors and uses Internet connection of the mobile to transmit monitored data to the server for doctor evaluation. The system gets measured data from patient monitor through patient mobile. However, the system basically doesn't allow entering data in the form of text, image, audio and GPS coordinates, and patients can't enter/send their status data through mobile phone

“Smart Phones” for Older Chinese with Diabetes

Microsoft Research and a group of researchers from several universities and Chinese medical centers are developing a smart phone-based self-management and support system for elderly diabetics in China. The system uses smart phones to send elderly diabetics recommendations and guidelines related to physical activity, glucose and blood pressure monitoring, weight measurement, and diet. Patients will be trained to enter and send data on glucose levels, and doctors will be able to track patient data and graphically display data for patients. The system allows data in the form of text. But it doesn't allow entering image, audio and GPS coordinate [22].

Mashavu: Networked Health Solutions for the Developing World

Mashavu (which means 'chubby-cheeked' in Swahili) is a computer-based system that enables doctors to connect with children in developing countries via mobile phones. Essential medical data (e.g., height, weight, blood pressure, and lung capacity) are collected at Mashavu stations in developing communities and sent by mobile phone to a remote server. Medical professionals can then 'electronically adopt' children by logging on to a web portal to monitor the children's health, provide feedback or advice to the child's caregivers, and collect health statistics. The system allows data in the form of text/number. But it doesn't allow entering image, audio and GPS coordinate [23].

MediNet

MediNet is a healthcare management system for diabetes and cardiovascular disease. The system is designed to relay information from patient monitoring devices to a central server via a cellular network. At the server, a data reasoning engine extracts all relevant information and alerts medical officers about severe cases. It also recommends appropriate responses such as a follow-up visit or phone call. The system can also send suggestions directly to patients via SMS message or pre-recorded voicemail. But it doesn't allow entering image and GPS coordinates and its implementation needs a lot of money [24].

SIMpill

The SIMpill solution is designed to help ensure compliance. SIMpill works by equipping a pill bottle with a SIM card and transmitter. When the pill bottle is opened, an SMS

message is sent to a designated healthcare worker. If the pill bottle is not opened when expected, the patient gets a text message reminder to take the medication. If the patient then fails to comply, the health worker is prompted to call or visit to encourage the taking of medication. However, the system basically doesn't allow entering data in the form of image, audio and GPS coordinates, and patients can't enter/send their status data through mobile phone [25].

2.3. ODK and SANA MOBILE HEALTH APPLICATIONS

D-Tree

The purpose of D-Tree is to aid clinicians by putting the Integrated Management of Childhood Illness (IMCI) onto mobile devices. There is a set of medical algorithms designed at the core of IMCI to guide health workers through the classification and treatment of children under five years old. ODK is at the heart of IMCI. Moreover, health workers can collect information including longitudinal patient data, type of visit, diagnosis, and prescribed treatment. This information can then be stored in the device and later uploaded into a central database system to generate statistical data for evaluation, research, or surveillance. But D-Tree is used to collect and record patients data and not for patient follow-up purpose. It doesn't support image, audio and video data format, and patients don't interact with it [26].

Sana Mobile

Sana Mobile is an open source mobile application and Tel-health platform that enables smart phones to conduct structured medical assessments and two-way sharing of sensitive medical data between a central medical record database and the mobile phone device. It has been designed to provide tools to streamline triage and the referral system, facilitate coordination of care, enable the delivery of real-time access to expert opinion, bring evidence based medicine into the hands of healthcare workers and help develop a database of decision support tools. Sana is totally used for healthy referral that is it connects health workers to medical professionals (experts). On the other hand, it is not for patient follow-up purpose and patients don't interact with it [27].

EpiSurveyor

EpiSurveyor is data collection system and enables public health and development professionals to create, share, and deploy health surveys. It enables users to easily create a handheld data entry form, collect data on a mobile device, and then transfer or upload the data back to a desktop or web server for analysis. It allows creation of surveys using the desktop application and seamlessly publishing them to the handheld devices. Data can be collected by field agents on their PDA's in the offline mode and can be synced to desktop application at convenience. The solution helps in eliminating the paper chain and making the entire process fast, efficient and free of error. However, EpiSurveyor is only used for data collection but not for patient follow-up and it only support text and location data format but not other data format(like: audio, video, image). Moreover, only the health workers access the system, but patients don't interact with it [28].

ODKClinic

ODK Clinic is a mobile phone medical record system. Health workers can download forms directly from OpenMRS, enter data as they see patients, and submit the data directly to OpenMRS. Clinicians can add images, audio or video to the patient record, data can be captured and uploaded to OpenMRS as well. In addition to this, clinicians can download a customizable patient list and view each patient's entire record. However, ODK Clinic is just a medical recording system but not for patient follow-up purpose and also patients can't interact with it [29].

AMPATH

AMPATH is a mobile phone data collection application for HIV treatment and developed using an open kit called ODK. It is used in a home-based testing and counseling program. The collected data will be submitted to a medical records system (OpenMRS) for analysis and follow-up. Counselor can be downloaded from and sent to OpenMRS directly over GPRS, take GPS coordinates within seconds, scan barcode ID cards into their phone in a few seconds. Moreover, the forms include video, audio, and images to assist counseling sessions. AMPATH is totally used for data collection purpose but not for patient follow-up and only accessed by health works and not by patients. In addition to this, it has one way communication, that is from mobile phone to server and mobile user can't access their submitted data [20].

The above review shows that most of the systems have shortcomings regarding entering data with GPS coordinates, image, video and audio formats. Moreover, there is no interface on the client side by which patients interact with the system using Amharic language as medium of instruction and fully dedicated to follow-up for out patients especially for those who have chronic condition. To overcome these difficulties, in this work we develop a new system by adapting Mobile open source which is flexible, and allows different types of format input including GPS coordinates, lets both patients and doctors to interact with the system just for patient follow-up using Amharic language.

3. SYSTEM ANALYSIS

3.1. CURRENT PATIENT FOLLOW-UP SYSTEM

Organizations which are in charge of facilitating condition to faster healthcare in Ethiopia could be categorized either private or public. Public healthcare organizations operate in an environment, more bureaucratic and slower to change compared to private ones. They operate within public service constraints, e.g. public and administrative laws, which have impacts on their planning, financing, and human resource management practices.

Patients arrive physically in health care organizations to start any kind of treatment. Even, they have to wait for hours, days, months and years to get treatment after their first registration. There are different steps that patients follow while they are in a hospital. First, the patient should report to the receptionist to get registered and the receptionist assigns the patient to specified doctors. Second, after they visit a doctor, patients follow either in-patient or out-patient procedures. In-patients are expected to stay in the hospital for days and get a follow-up by their doctors until they recover from their problem. Where as, out-patients, usually get their treatment and stay in their home and be back to the hospital on their appointment schedule for further follow-up. Out-patients, especially patients coming from rural areas, need to remember their schedule and travel long distance to arrive on time.

Currently, public health care organizations have employed manual and paper based system for patient registration and follow-up. Moreover, they have no system to handle and follow-up out-patients since patients are in their home and doctors in their office.

3.2. PROPOSED PATIENT FOLLOW-UP SYSTEM

3.2.1. Overview

The current system study shows that public healthcare organizations have a lot of problems. To minimize the problems, the system to be developed (m-health) will support long term out-patients follow-up treatment activities and create remote reliable communication between health workers and outpatients.

Using system server side interface, health professionals can register patients and record any type of patient treatment and diagnosis results (like lab, x-ray, ultrasound etc). Moreover, they can give follow-up and recommendations to their out patients in remote area. This helps health professionals and organizations give quality of service on time, avoid patient crowding, and job dissatisfaction and inefficient.

Also, the system supports patients to communicate with their doctors while they are at home using mobile phone. In so doing, patients can get follow-up services from their home instead of returning to hospital. This helps patients avoid transportation cost, traveling long distance and other related challenges.

The proposed system is strongly believed to address the very limited reach of specialists who are often confined within a few large cities in developing countries. Follow-up of chronic conditions that may require technology not available in remote areas will also be made easier with this system. It would also be instrumental in scaling up remote real-time access to specialists. For example, follow-up of patients with multi-drug resistant tuberculosis can be assisted by periodic chest x-rays and the system can assist the automatic upload of the x-ray into the electronic medical record for diagnosis.

3.2.2. Functional Requirements

The main functional requirements of the system include the following services.

System Phone Service

Using the system phone service, out-patients run a procedure and enter their data. Then, it uploads the data to the system server for doctor review. After reviewing the case, doctors notify the patients by sending diagnose result to the system phone service. Moreover, the service is responsible for:

- Reloading database from the system server
- Synchronizing with the system server
- Scanning linear or QR barcode from patient ID card
- Uploading completed cases (filled out forms) to the system server
- Uploading cases via background service when data connection is available
- Collecting GPS, Picture, and Audio data, in addition to all common forms of text entry
- Viewing previously completed cases
- Receiving diagnosis / treatment recommendation via SMS and display notification to patient.

Dispatch Management Service

The system consists of at least one (and in most instances several) phones and a web-connected server. The server runs both diagnose service and the dispatch management service (DMS). The DMS runs on the server that is responsible for communication to/from phone and diagnose services.

Diagnose Service

This service allows doctors to diagnose incoming cases from the patients. In addition to this, it is responsible to:

- Make commentary and diagnosis recommendations. These are transmitted back to the phones via SMS and e-mail
- Show all the responses to questions in a given form that were uploaded from a phone
- Store all recommendation for further observations.

System Utility Service

This service will be responsible for managing users' access to the system. That is,

- Add/Edit/Remove system user
- Login/Logout system user

3.2.3. Non-Functional Requirements

These requirements are not designed for the functional behavior of the system. They express how well the system provides services to the users. The following are non-functional requirements of the system.

User Interface and Human Issue

There are different user interfaces included to support users of the system. Patients can easily interact with the system using forms which run on mobile phone. Furthermore, health professionals can access the system through web browsers on their personal computer. Both patients and health professionals can fill, save, edit, send and open forms and will have captions both in English and Amharic languages.

Hardware and Software

The system will need server operating system (Ubuntu Linux 10.4) to deploy dispatch management module and diagnose module, and computer with at least 3 gigabytes of available hard drive space and 512 megabytes of RAM. On the client sides smart phones with Android 1.6 or later are required to deploy phone module. Normal personal computers are needed to access the system through web browsers. GSM or WiFi Internet connection is necessary for communication between the users and the system.

Performance

Different users can access the system for different or same issues. Unless there are Internet connections, hardware and software requirement constraints, the system can support many users and execute their queries at the same time.

Security

Only authorized users can access the system. That is, patients must enter their username and password to the system interface to access the system through their mobile phone. Similarly, health professionals and system administrators can access the system through web browsers by using their username and password. Moreover, the system is developed and implemented using different open sources (like Ubuntu linux, apache tomcat and ant, SQL, JDK) and these makes the system more secure from unauthorized user and access.

Privacy

The privacy of patients' data and information are secure through the system security. In clear terms, any exchanged data between patients and health professionals are kept in system database and only authorized person can access it.

Maintainability and Expandability

Based on the system that advocates owner interest and activities, the system will be maintained and expanded. In addition, the system designed using an object oriented approach; any developer that is familiar with the code can maintain, expand and modify it.

Error Handling

Most of the errors will come from either misusing of the system or coming up with invalid input. Likewise, malfunction of the system may result in errors. The system will help handle these errors through system exception handling mechanisms and notify the appropriate solution.

4. SYSTEM MODEL

4.1. USE CASE

Actors of the System

There are different actors that interact with the system. Table 4.1 shows those actors with their description.

Table 4.1: System actors' descriptions

	Actor	Description
1	Patient	A patient is an authorized user of the system through mobile phone to get follow-up service at home and responsible for filling, saving, sending forms to the system and opening forms that come from the system.
2	Health Professional	This is a person who has an authorized access to the system and responsible for patient follow-up by diagnosing patient's request and sending the result.
3	System Administrator	This is a person who is responsible for the function of the system and to administer the system users.

Use Case Diagram

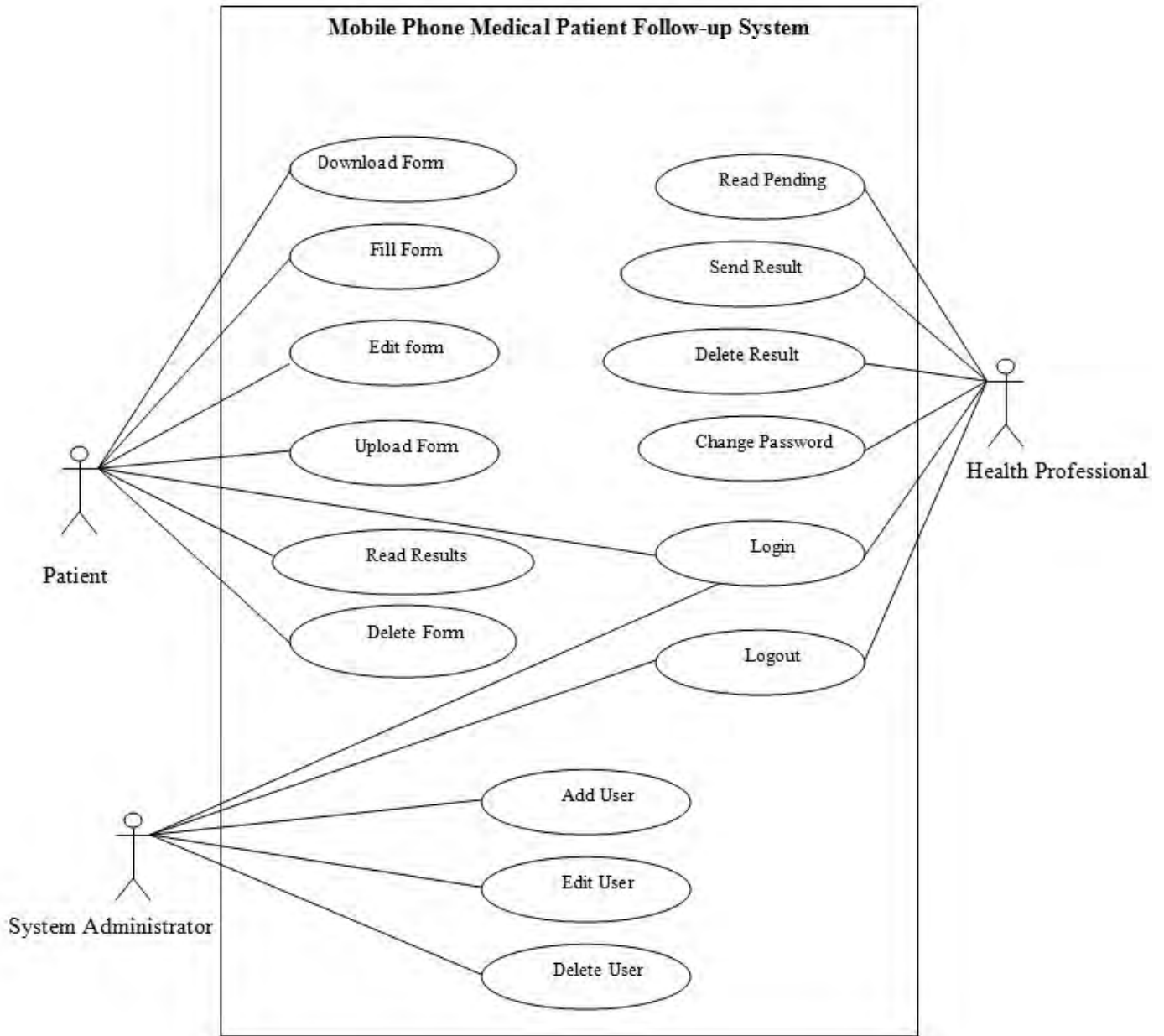

Figure 4.1: Use case diagram

Use Case Description

Table 4.2: Use Case Descriptions

Use case Name	Download Form
Actors	Patient
Description	Allow patient to get new form (producers) from the server.
Pre-condition	The patient must be logged into the system
Flow of events	<ol style="list-style-type: none"> 1. The patient selects the application to lunch it on the phone. 2. The system displays user interface and menu 3. The patient selects Menu from main menu 4. The patient selects download form button. 5. The system downloads all the forms (procedures) into the phone.^{A1}
A1	<ol style="list-style-type: none"> 1. The system displays “Unable to download”. 2. The patient repeat steps 4 and 5. Otherwise, terminate the system.
Post-condition	New forms (procedures) are downloaded.

Use case Name	Fill Form
Actors	Patient
Description	This allows patients to fill their follow-up status
Pre-condition	The patient must be logged into the system
Flow of events	<ol style="list-style-type: none"> 1. The patient selects the application to lunch it on the phone. 2. The system display user interface and menu. 3. The patient selects “Start New Encounter” to start filling. 4. The system displays all the available forms/procedures. 5. The patient Scroll through the list of available procedures and select one procedure. 6. The patient fills his personal and follow-up case with different data format. 7. The patient selects “Save for Later Upload”^{A1} 8. The system saves the filled form for future use.
A1	<ol style="list-style-type: none"> 1. The patient selects “Upload” button to begin sending the filled form to the server with out saving.
Post-condition	A form will be filled successfully.

Use case Name	Edit Form
Actors	Patient
Description	Allow patient to edit the filled forms before sending it to the server.
Pre-condition	The patient must be logged into the system
Flow of events	<ol style="list-style-type: none"> 1. The patient selects the application to lunch it on the phone. 2. The system display user interface and menu. 3. The patient selects “View Saved Procedures” 4. The system display saved forms. 5. The patient selects “View Page List” to go back to the beginning of the procedure and edit all the answers entered. 6. The patient selects “Save for Later Upload”^{A1} 7. The system saves the edited form for future use.
A1	<ol style="list-style-type: none"> 1. The patient selects “Upload to server” to begin sending it to the server with out saving.
Post-condition	The system update/edit filed forms

Use case Name	Upload Form
Actors	Patient
Description	This allows patient to send filled procedure to the server
Pre-condition	<ol style="list-style-type: none"> 1. The patient must be logged into the system 2. The patient must fill the form.
Flow of events	<ol style="list-style-type: none"> 1. The patient selects the application to lunch it on the phone. 2. The system display user interface and menu. 3. The patient selects “View Saved Procedures” to view saved procedures/forms. 4. The system display saved forms. 5. The patient selects the filled form to be uploaded. 6. The patient select the menu to get upload button 7. The patient then hit “Upload” button to upload the form 8. The system sends the filled form to the server.
Post-condition	The filled form/procedures will be uploaded.

Use case Name	Read Result
Actors	Patient
Description	Allows patient to read diagnose result message which sent by his doctor.
Pre-condition	The patient must be logged into the system
Flow of events	<ol style="list-style-type: none"> 1. The patient selects the application to lunch it on the phone. 2. The system display user interface and menu. 3. The patient selects “View Notification” button to read the received messages. 4. The system displays the received messages 5. The patient selects “Save” button to after reading the message.^{A1} 6. The system save the message for future use
A1	<ol style="list-style-type: none"> 1. The patient can discard the message after reading by selecting “Discard” button
Post-condition	Reading the received message.

Use case Name	Delete Form
Actors	Patient
Description	This allows patient to send filled procedure to the server
Pre-condition	The patient must be logged into the system
Flow of events	<ol style="list-style-type: none"> 1. The patient selects the application to lunch it on the phone. 2. The system display user interface and menu. 3. The patient selects “View Saved Procedures” to view saved procedures/forms 4. The system display saved forms. 5. The patient selects the one of the saved forms to be delete 6. The patient select menu. 7. The system display delete button. 8. The patient then hit “Delete” button 9. The system will delete the selected saved form.
Post-condition	The saved form/procedures will be deleted.

Use case Name	Read Pending
Actors	Health Professional
Description	This allows health professional to read pending diagnose which sent by patients.
Pre-condition	The health professional must be logged into the system.
Flow of events	<ol style="list-style-type: none"> 1. The health professional selects Pending tab across the top menu bar 2. The system will display the pending cases. 3. The health professional selects one of the pending case 4. The system open the selected pending case 5. The health professional read and diagnose the case.^{A1}
A1	<ol style="list-style-type: none"> 1. The health professional selects “Retake” button to receive a prompt to send a message to the patient who uploaded the case asking for more information before a diagnosis can be made.
Post-condition	New pending case will be read.

Use case Name	Send Result
Actors	Health Professional
Description	This allows health professional to send diagnosed result to patient.
Pre-condition	The health professional must be logged into the system.
Flow of events	<ol style="list-style-type: none"> 1. The health professional selects Pending tab across the top menu bar 2. The system displays all the pending cases. 3. The health professional selects one of the pending case 4. The system open the selected pending case 5. The health professional read and diagnose the case. 6. The health professional determine the urgency level of the patient case as “emergency,” “urgent,” or “non-urgent.” 7. The health professional type diagnosis result and any other comments. 8. The health professional selects “Send” button to send the result to the patient 9. The system sends diagnosis result to the patient mobile phone.
Post-condition	The diagnosed result will be sent and the case status will be changed into closed.

Use case Name	Delete Result
Actors	Health Professional
Description	This allows health professional to delete closed cases.
Pre-condition	The health professional must be logged into the system.
Flow of events	<ol style="list-style-type: none"> 1. The health professional selects Pending tab across the top menu bar 2. The system displays all the pending cases. 3. The health professional selects one of the closed cases. 4. The health professional selects “Delete” button to remove the selected case. 5. The system deletes the case permanently.
Post-condition	Delete the closed cases.

Use case Name	Change Password
Actors	Health Professional
Description	This allows Health professional to change his password.
Pre-condition	The health professional must be logged into the system.
Flow of events	<ol style="list-style-type: none"> 1. The health professional selects Administration tab across the top menu. 2. The system display change password Manu. 3. The health professional enter this old and new password. 4. The system change and stored the new password.
Post-condition	Password is changed.

Use case Name	Login
Actors	Patient, Health Professional and System Administrator
Description	This allows to identify system users and to access system functionality.
Pre-condition	The users must have username and password.
Flow of events	<ol style="list-style-type: none"> 1. The system displays login form. 2. The user enters username and password. 3. The system validates users input.^{A1} 4. The user logged in to the system.
A1	<ol style="list-style-type: none"> 1. The system displays error message. 2. The user repeat step 2. Otherwise, the user terminates login form.

Post-condition	Login will be done.
-----------------------	---------------------

Use case Name	Logout
Actors	Health Professional and System Administrator
Description	Allows user to log out from the system.
Pre-condition	The user logged in.
Flow of events	<ol style="list-style-type: none"> 1. The user selects log out button. 2. The system logout and display the home page.
Post-condition	The user logout.

Use case Name	Add User
Actors	System Administrator
Description	Allows system administrator to create new system users.
Pre-condition	The system administrator must be logged in to the system.
Flow of events	<ol style="list-style-type: none"> 1. The system administrator select “Administration” tab 2. The system display administration page. 3. The system administrator select “Add New User” button. 4. The system display new form 5. The system administrator fills new user profile and selects “Create” button. 6. The system creates new system user.
Post-condition	New system user will be added.

Use case Name	Edit User
Actors	System Administrator
Description	Allows system administrator to edit registered system users.
Pre-condition	The system administrator must be logged in to the system.
Flow of events	<ol style="list-style-type: none"> 1. The system administrator select “Administration” tab 2. The system display administration page. 3. The system administrator identifies the user whose profile will be edited. 4. The system administrator edits the user profile and clicks “Update” button. 5. The system updates the user profile.
Post-condition	System user’s profile will be edited.

Use case Name	Delete User
Actors	System Administrator
Description	Allows system administrator to delete system users.
Pre-condition	The system administrator must be logged in to the system.
Flow of events	<ol style="list-style-type: none">1. The system administrator select “Administration” tab2. The system display administration page.3. The system administrator identifies the user who will be deleted.4. The system administrator selects the user and clicks delete button.5. The system deletes the user profile
Post-condition	The user will be deleted.

4.2. CLASS DIAGRAM

The following Figure 4.2 describes the class diagram of the system with their attributes, methods and relationships. Moreover, it shows the overall structure of the system.

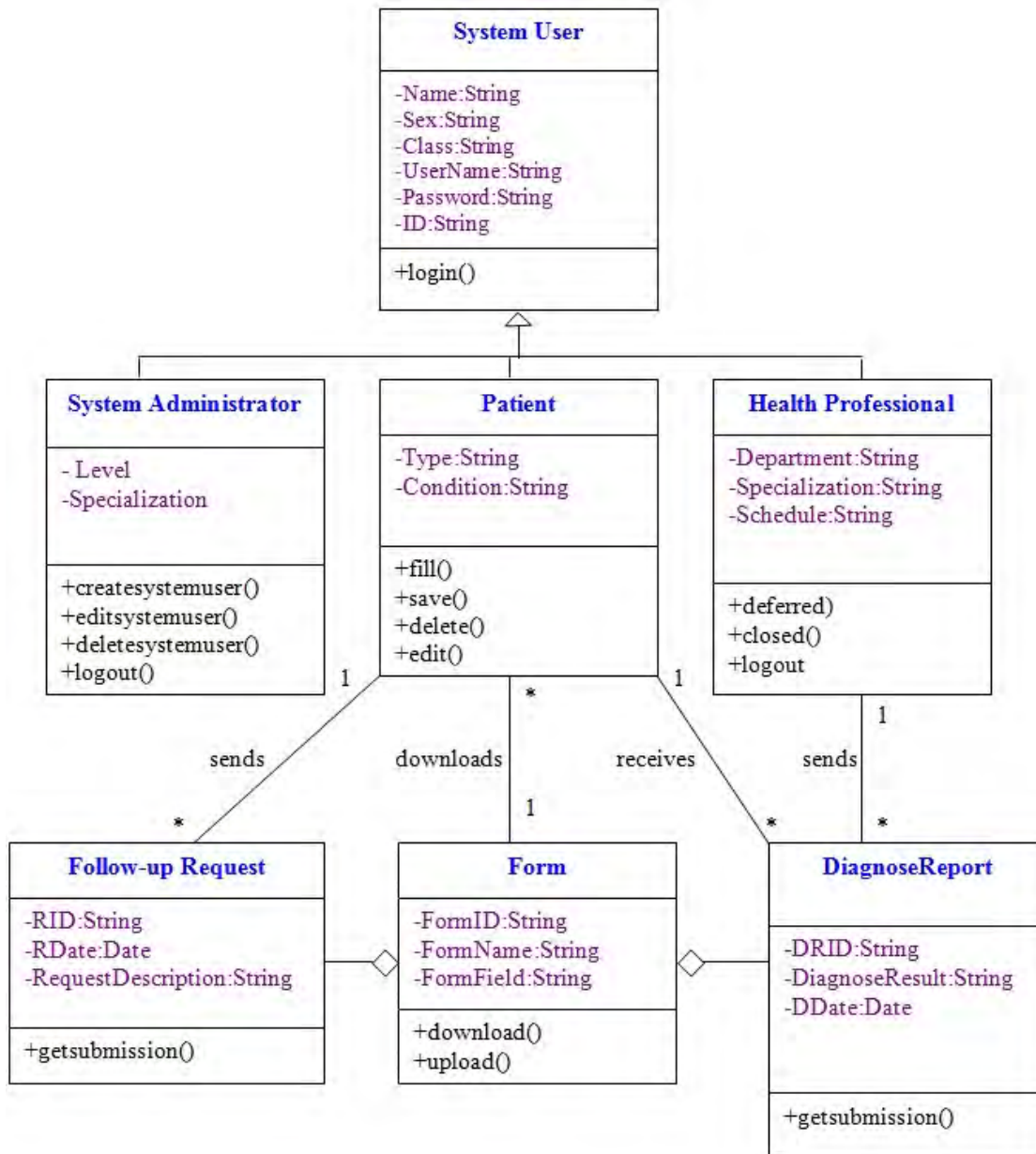

Figure 4.2: Class Diagram

4.3. SEQUENCE DIAGRAM

This sequence diagram expresses the behavior of the system

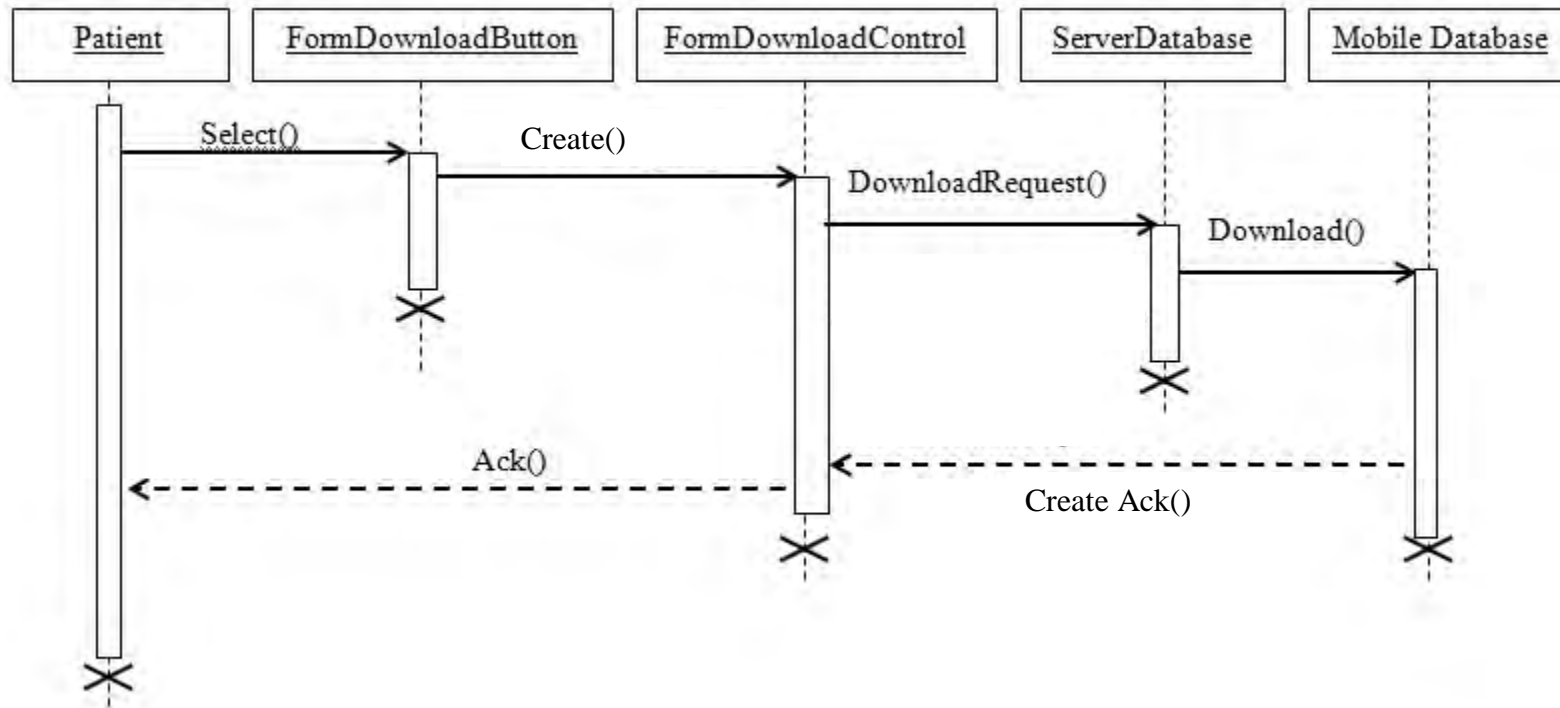

Figure 4.3: Form download sequence diagram

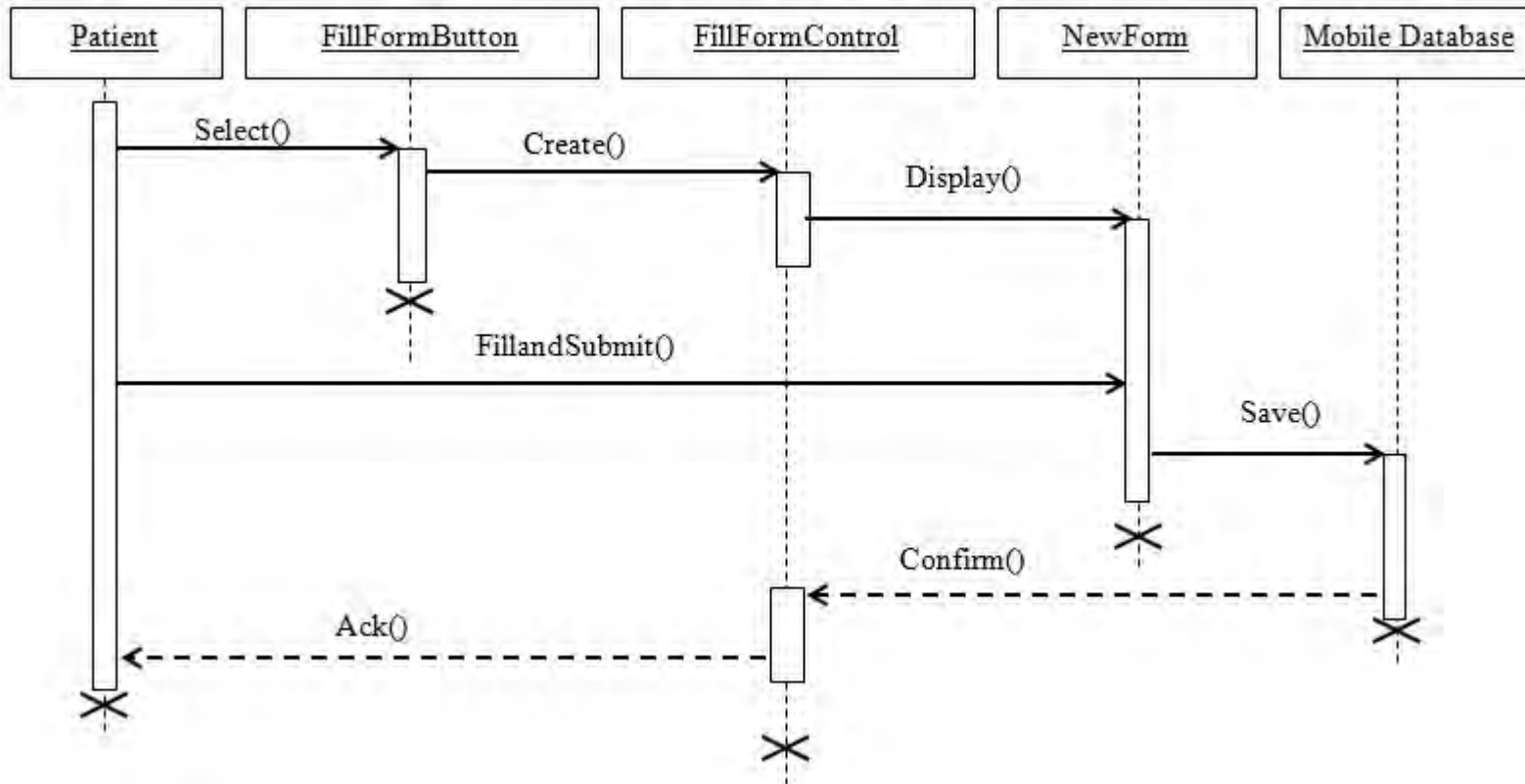

Figure 4.4: Fill form sequence diagram

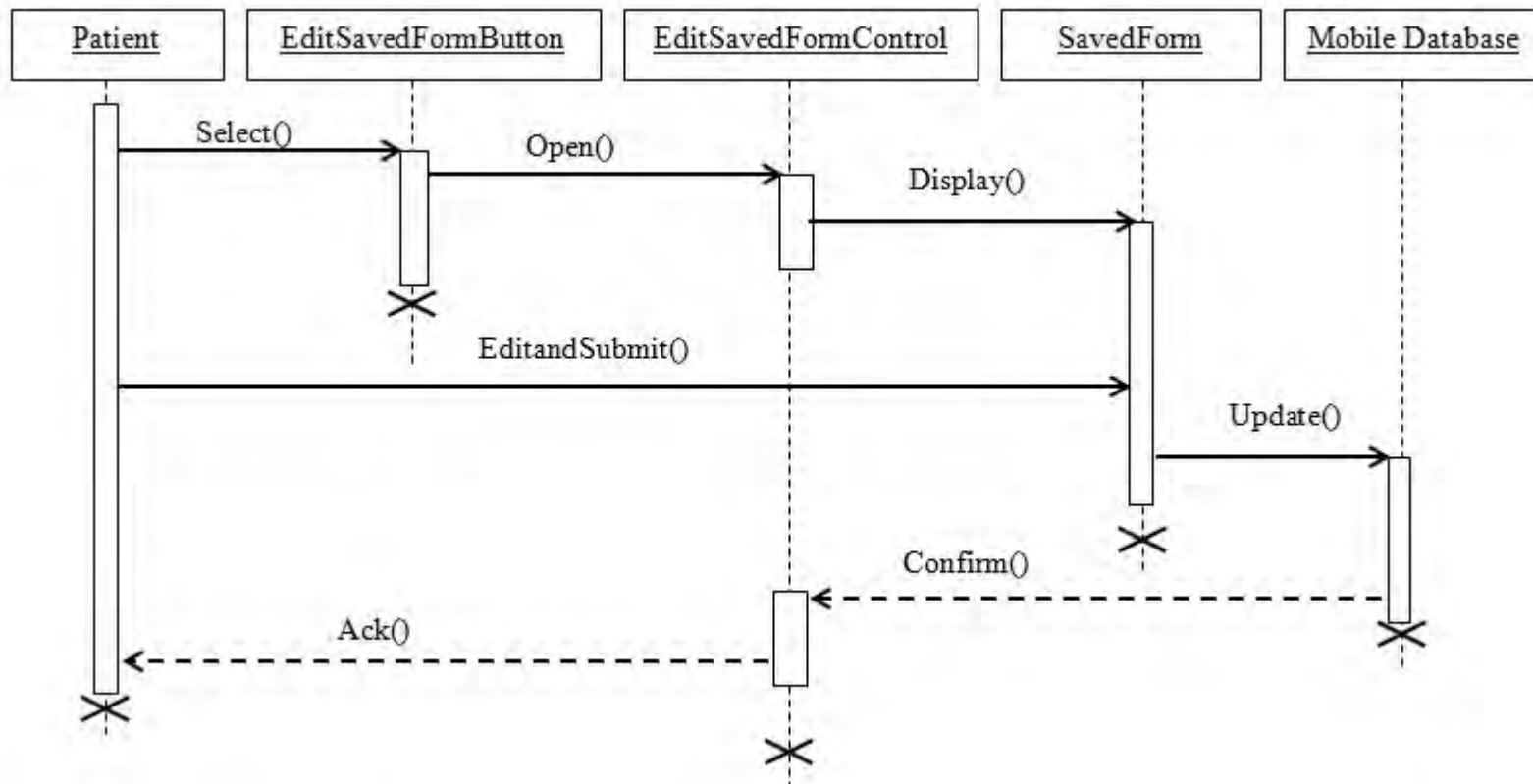

Figure 4.5: Edit form sequence diagram

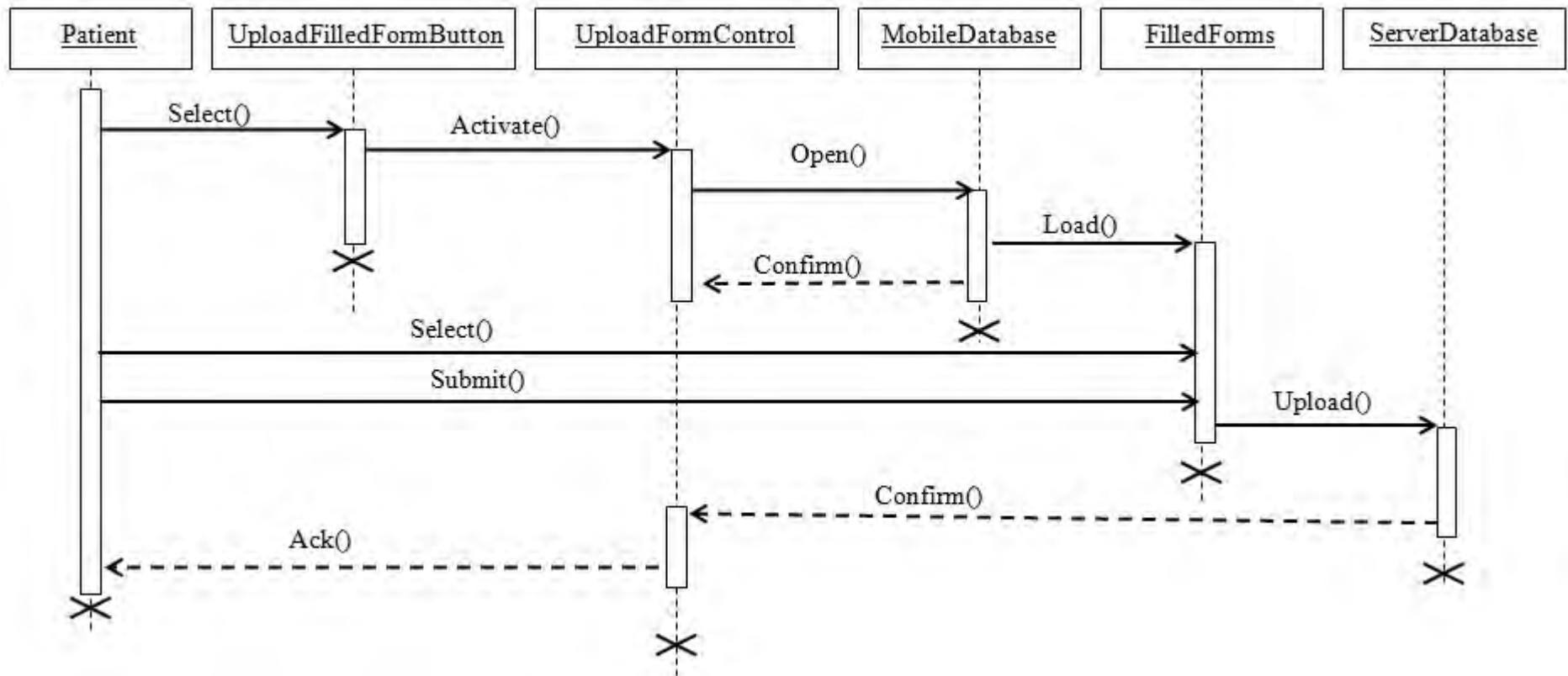

Figure 4.6: Upload form sequence diagram

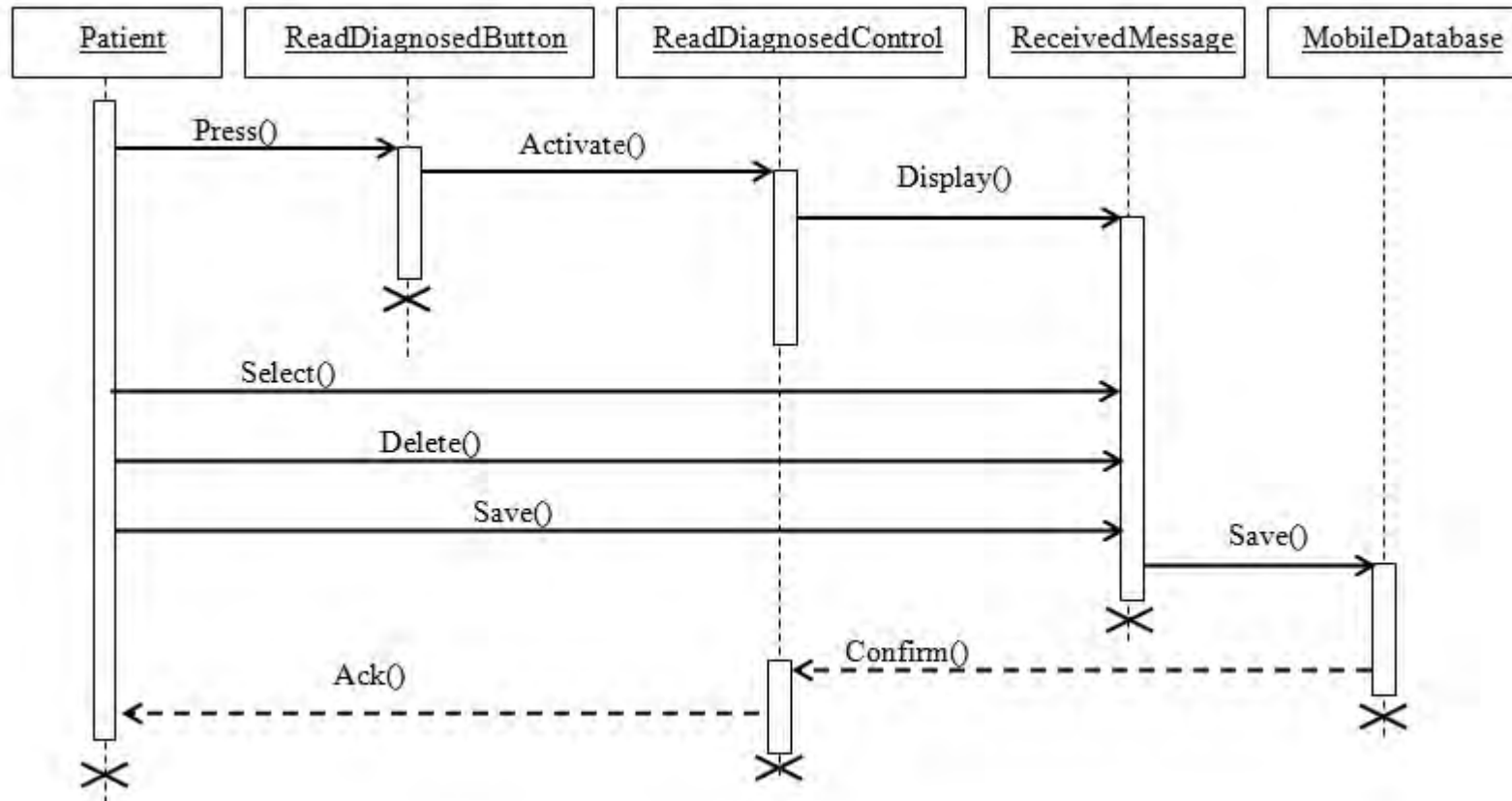

Figure 4.7: Read Result sequence diagram

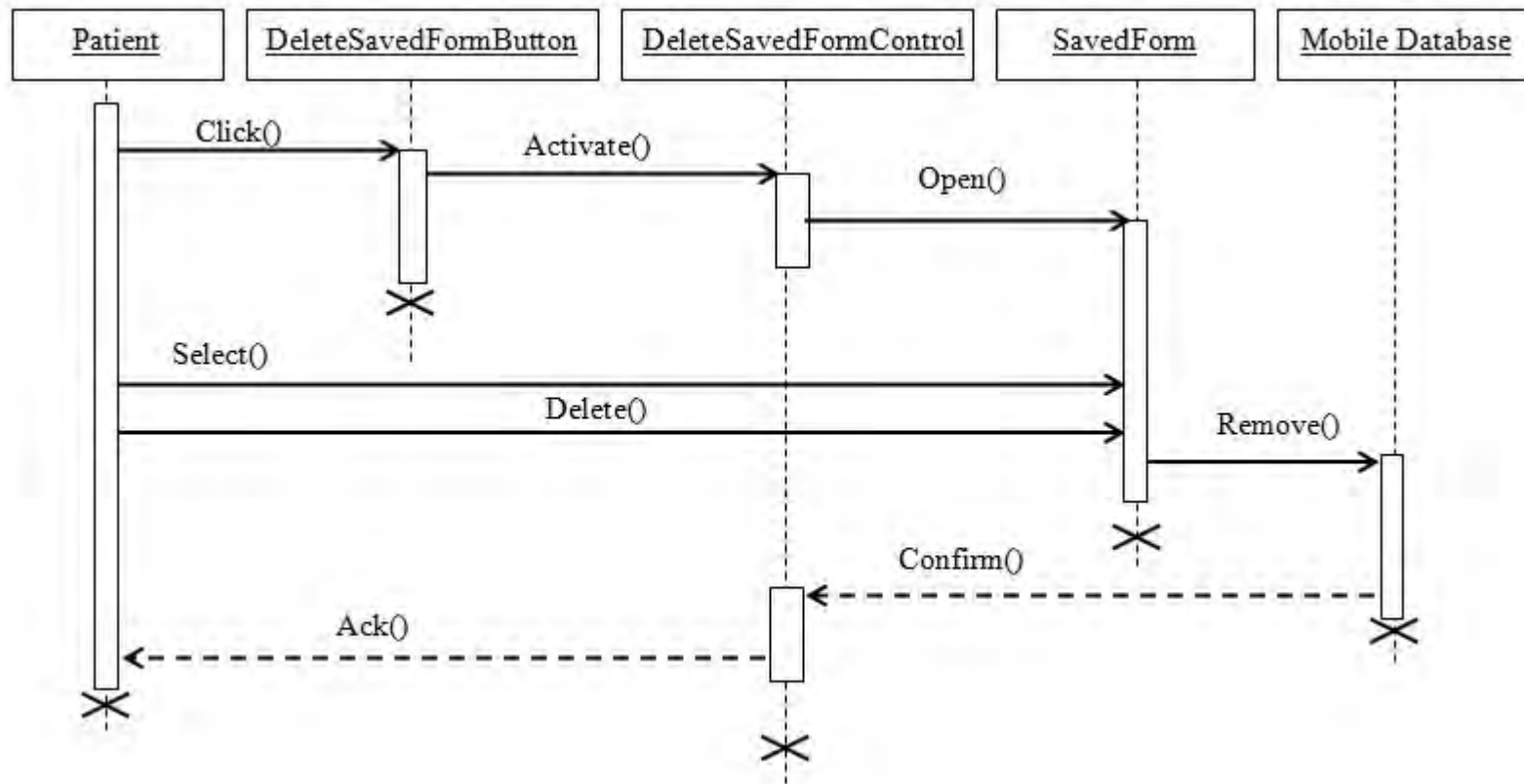

Figure 4.8: Delete form sequence diagram

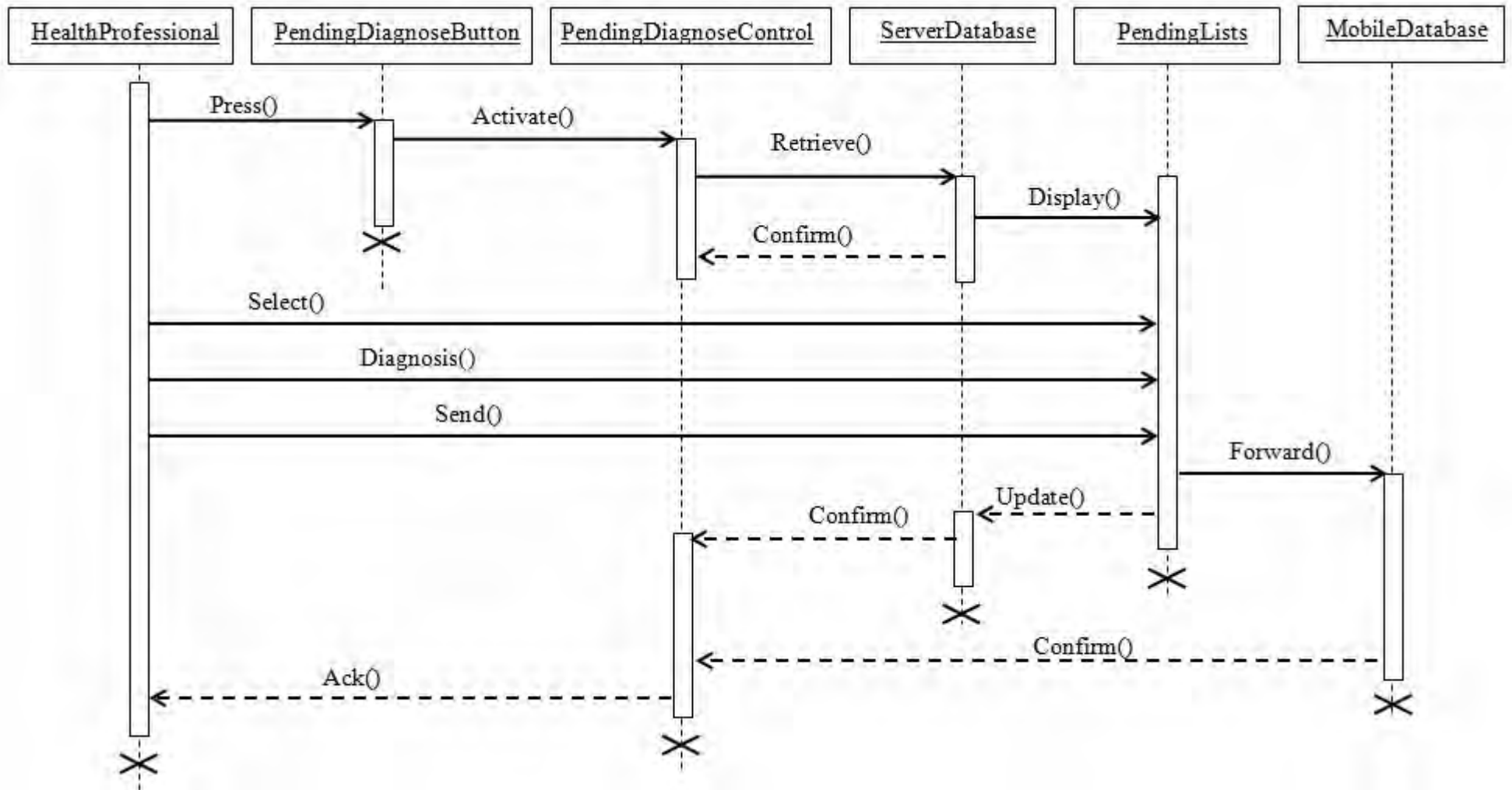

Figure 4.9: Send result sequence diagram

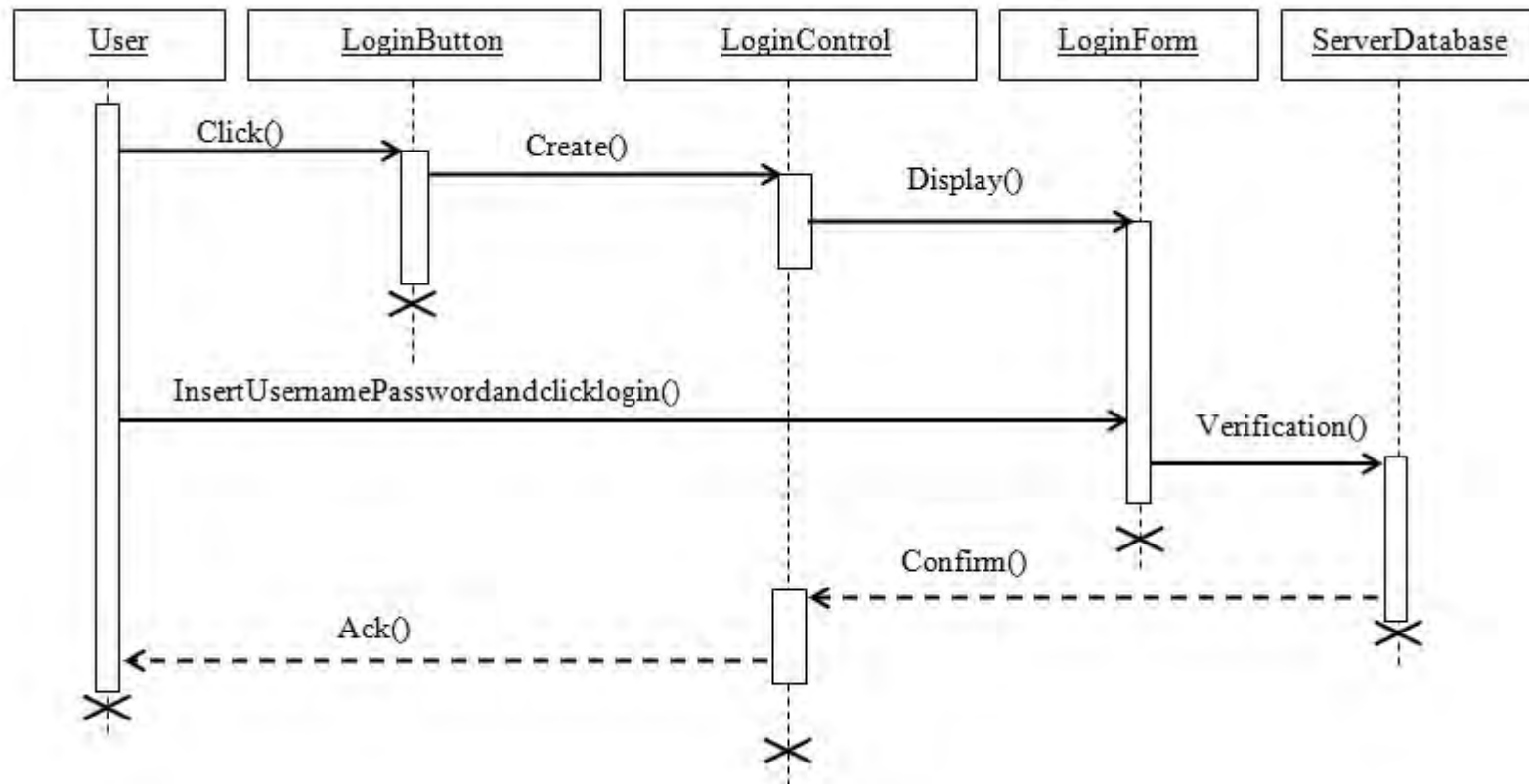

Figure 4.10: Login sequence diagram

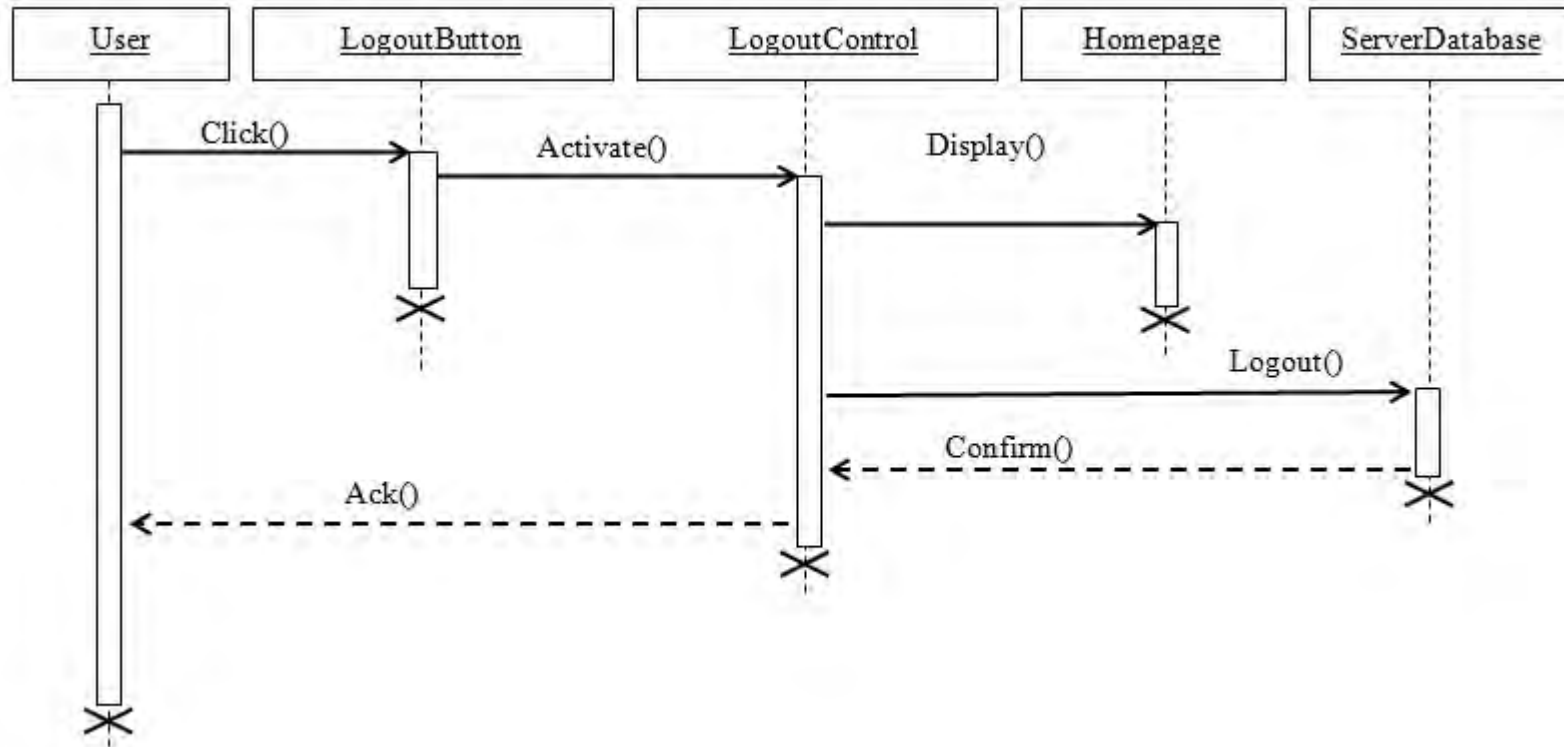

Figure 4.11: Logout sequence diagram

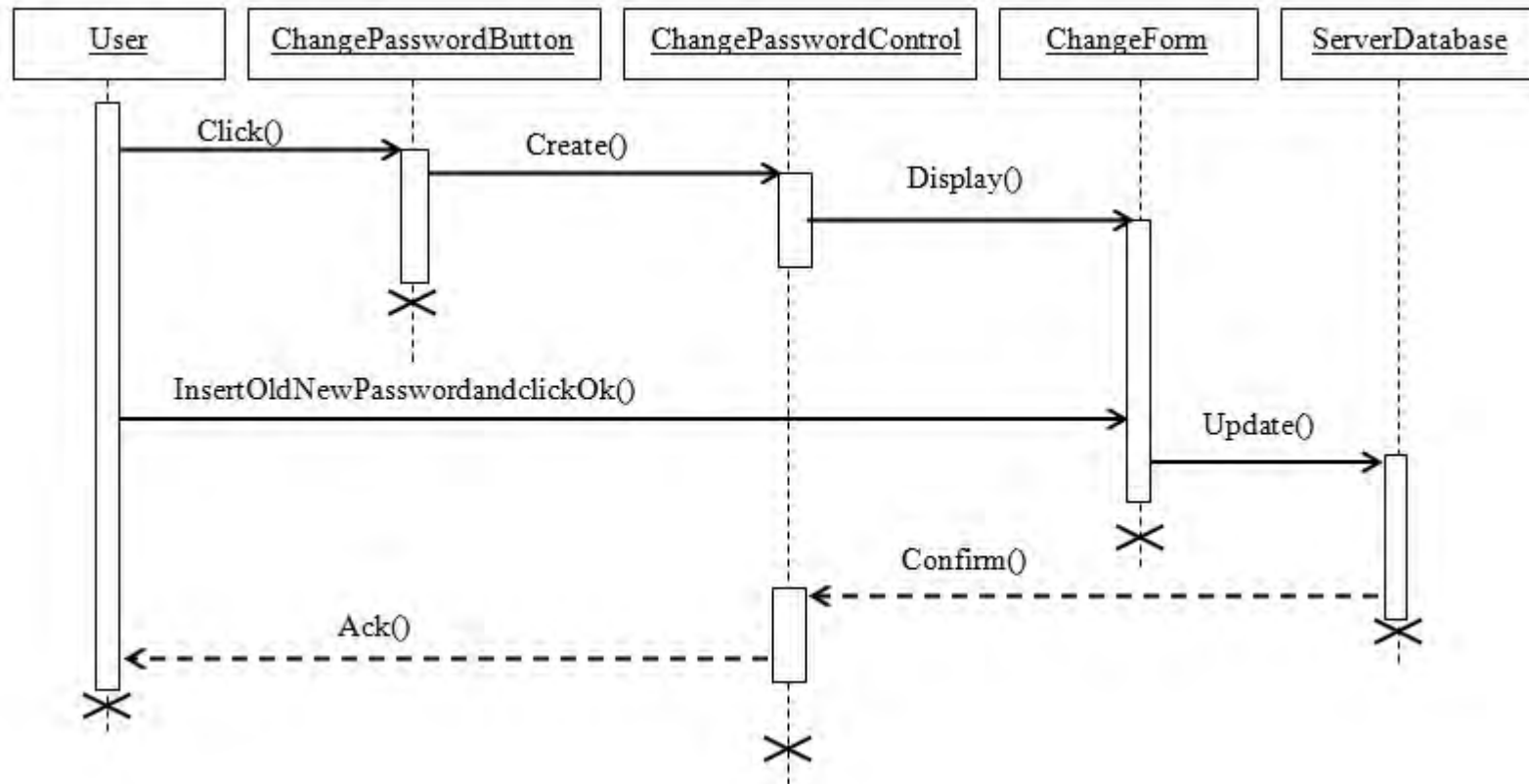

Figure 4.12: Change password sequence diagram

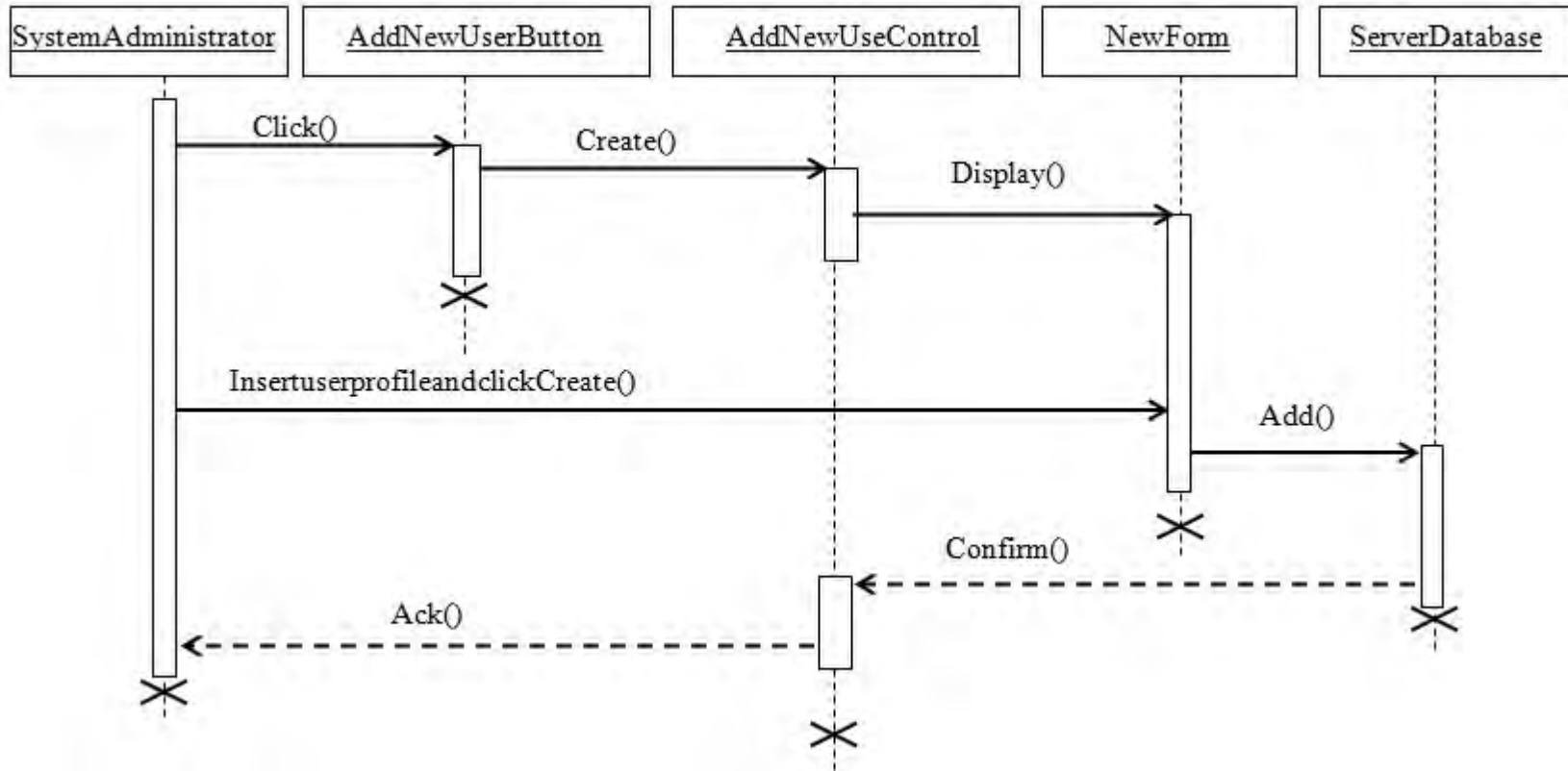

Figure 4.13: Add new user sequence diagram

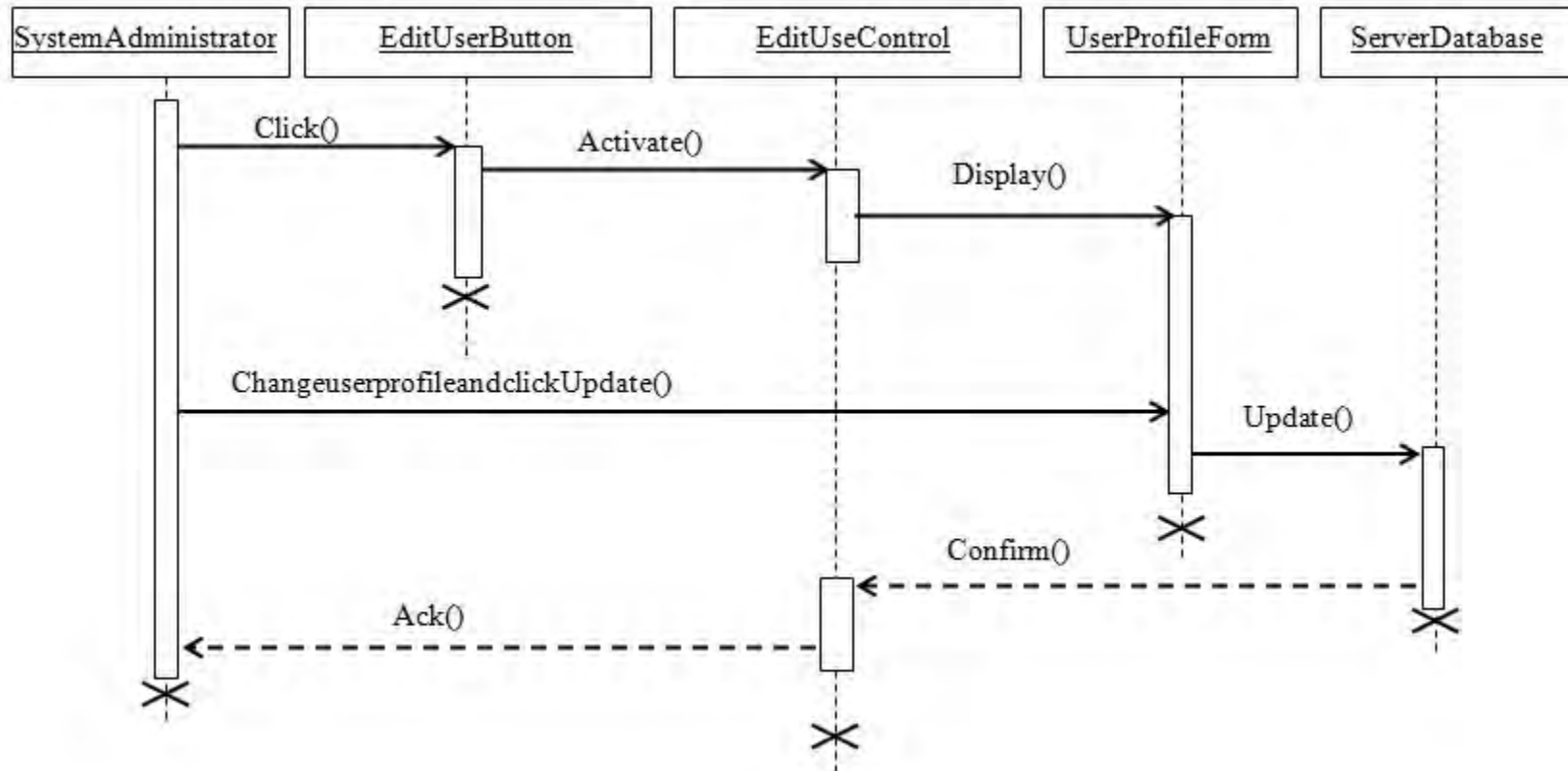

Figure 4.14: Edit user sequence diagram

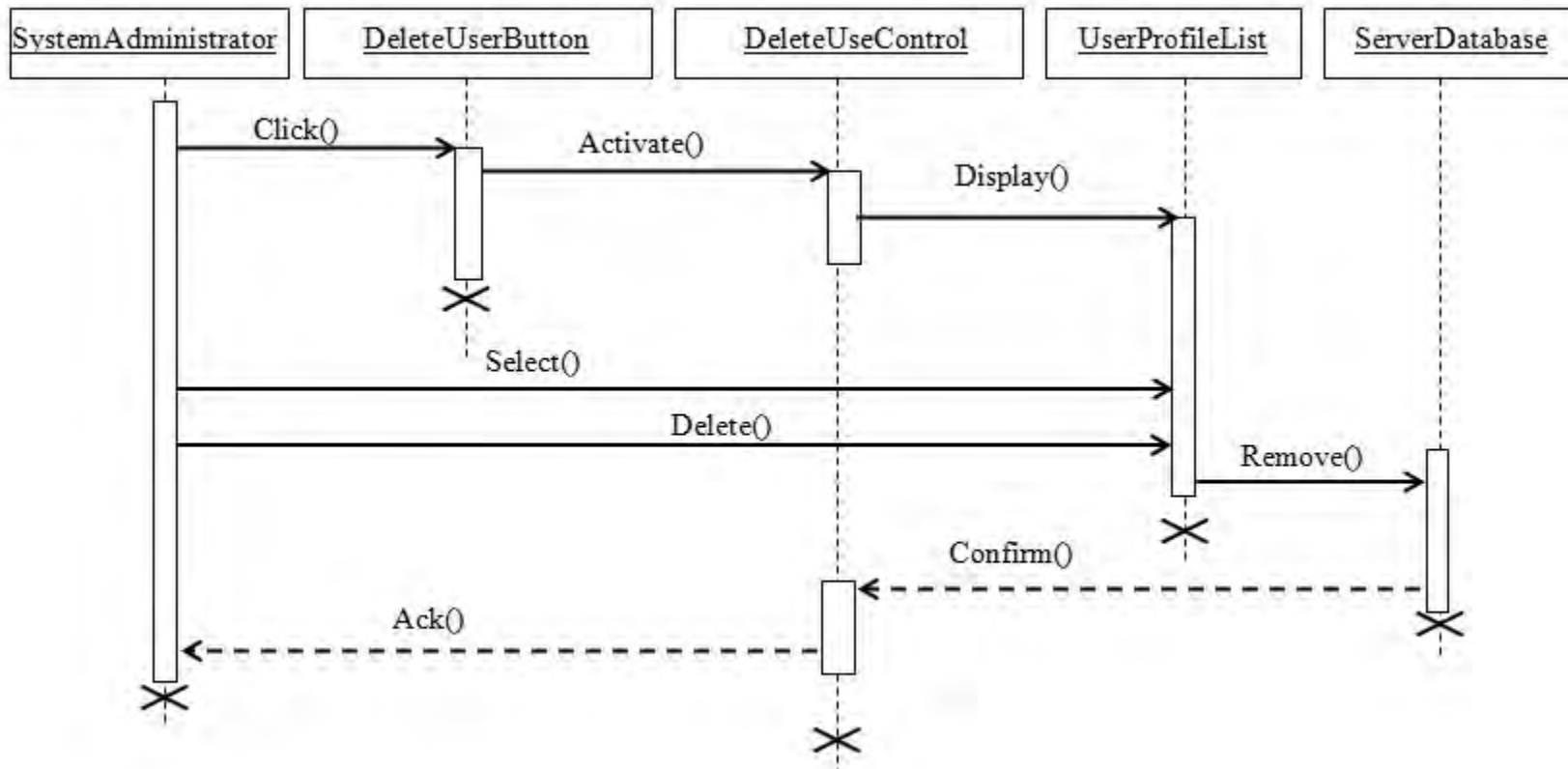

Figure 4.15: Delete user sequence diagram

5. SYSTEM DESIGN

This section describes the proposed solution the system should have by transforming the functional requirements into subsystem decomposition and the non-functional requirements into design goals.

5.1. DESIGN GOALS

Design goals show the system qualities on the perspective of the system's non-functional requirements. The following are design goals that are expected to be achieved in the system.

Performance

Unless there are, hardware and Internet connection constraints, the system can handle multiple users request at the same time and responsive to user's requests.

Security

System users' authentication with username and password are playing big roles in ensuring security. Therefore, the system is secure from unauthorized user access.

User Interface

User interfaces are simple and flexible and users can easily learn them. In addition, most of the system users are familiar with normal mobile and web application, and this help them manage and adapt the system user interfaces with in short time, and easily understand the user manual.

Availability

Unless otherwise, power, Internet connection and others constraints interfere, the system is available and can give service for 24 hours.

Cost

Based on the target and mission of the system owner, the system implementation would run at reasonable cost. Although, the system works on smart phones, the big challenge it might face with is affording mobile cost. However, this challenge deals with by Google Company and in the near future we expect a good solution.

Portability

Patients can access the system through any mobile phone with android operation system. Healthcare professional and system administrator can access the system through web browsers with all platforms.

Maintainability

The system is designed with Object oriented approach and different modules. Therefore, any developer can easily maintain and modify without affecting other parts.

5.2. PROPOSED SYSTEM MODEL

5.2.1. System Architecture

This system architecture shows the overall organization and communication between the users and the system, and its components: mobile phone client, web client and system server. The following figure 5.1 shows the system architecture of the system.

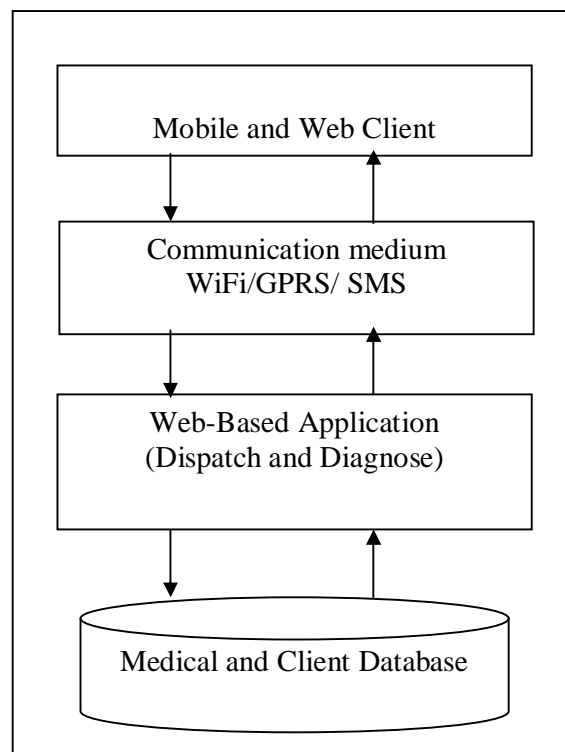

Figure 5.1: System Architecture

System Mobile Phone Client

This component helps patients to communicate with their doctors. It contains different forms, procedures and settings which patients fill in their follow-up cases. Moreover, it runs on Android operating system and uses GPRS and WiFi networks to communicate with the web application.

Web-Based Application

The Web application of the system is the heart of the system. It is responsible for any kind of communication among patients, health professionals and system administrator through its dispatch module. That is, it supports health professionals to diagnose and respond patients follow-up cases through diagnose module, and system administrator to manage the system through Utility module.

System Web Client

Through this component, system administrator can manage and access the system. Moreover, health professionals can diagnose and follow-up patient cases using this component.

Medical and Client Database

This system database contains patient medical record, system user information, and diagnosed result. It handles user and application request through the system diagnose module.

5.2.2. System Decomposition

This system decomposition describes the services of the system that will be given to the user. Also, it shows the subsystems decomposition on the entire system. The following figure 5.2 shows subsystem decomposition of the system.

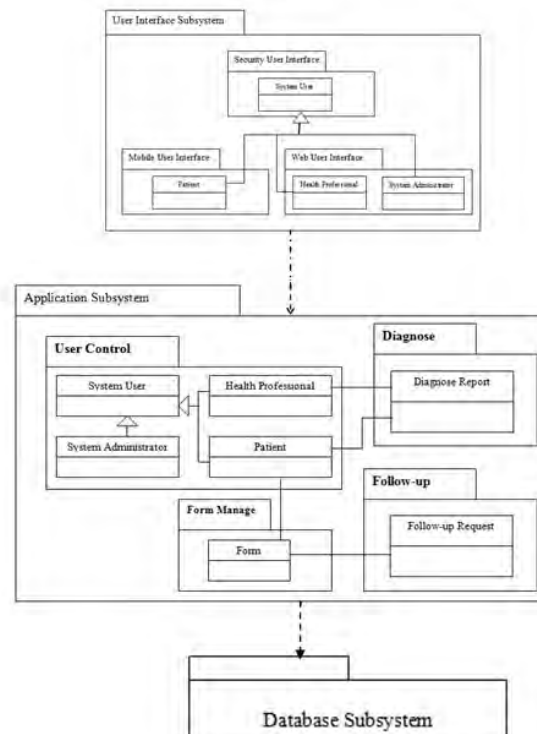

Figure 5.2: Subsystem Decomposition

User Interface Subsystem

This subsystem is mainly responsible to facilitate the interaction of the user with the system. The services at this subsystem are accepting user inputs, shaping them in such way that they can be used by the system, and displaying results processed by the system. This subsystem has three smaller subsystems: Security User Interface, Mobile User Interface and Web User Interface.

Application Subsystem

This subsystem is mainly responsible for managing any operation and communication in relation to diagnose, patient follow-up request, and user control. This subsystem is decomposed into four main subsystems: User control, Diagnose, Follow-up and Form Manage

Database Subsystem

The main task of this subsystem is providing facilities for data storage, executing the SQL statements that come from the application subsystem, and ensuring data consistency. It also facilitates storage and retrieval of files.

Hardware Software Mapping

This mapping model describes the hardware and software components, and communication technology that will be used for the system. Moreover, it shows the middleware component that is used to connect disparate clients to the central server. The following figure 4.3 shows the two tires hardware/software mapping of the system.

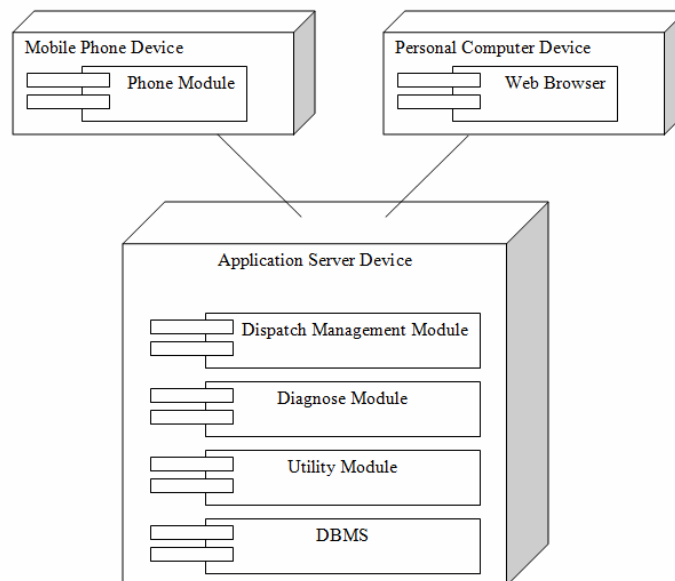

Figure 5.3: Deployment Diagram

5.2.3. Persistent Data Management

Every communication and activity in the system generates different data, such as patient follow-up request, diagnosed report and recording patient profile. Moreover, these data need relation, integration and persistent data management to achieve the system design goals. The following figure 4.4 shows the system's relational model that handles data relation, integration and persistent data management.

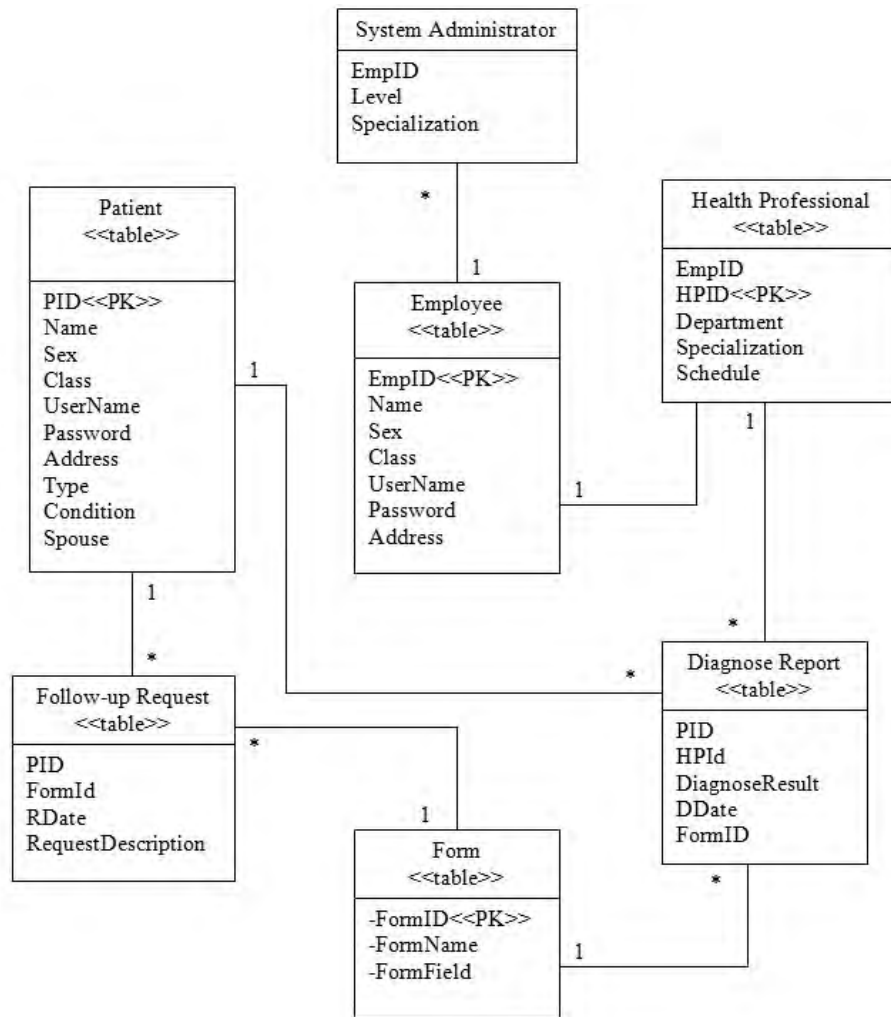

Figure 5.4: System Relational Model

6. IMPLEMENTATION

The implementation part of the system incorporates different development environment which are more powerful for smart phone and server side application development. The following section presents the tools that are used in the development environment and prototype.

6.1. DEVELOPMENT ENVIRONMENT

Android SDK

The Android SDK tools and plug-in are used to begin and facilitate developing phone module applications of the system on the Android platform using the Java programming language.

Android Emulator

Android Emulator is used as a virtual mobile phone for deploying and testing the system's mobile side application before using the actual mobile phone.

Eclipse 3.6 (Helios)

Eclipse is used as an integrating development environment and to plug-in android ADT.

Java 2 Enterprise Edition (J2EE)

J2EE is language used to develop the mobile and server side application of the system.

Java Persistent API

Java Persistent API is used for data storage management using the Java Data Object.

Ubuntu 10.04

It is used for server operating system and to deploy and run Dispatch and Diagnose module of the system.

MySQL

It is used for database management of the system and integrates the interaction between client, Dispatch and Diagnose module.

Apache TOMCAT/Ant

It is a web service tool that is used to access the system through web browsers for health professional and system administrator.

Kannel

Kannel is an *SMS gateway* for GSM networks. It is used to implement an SMS communication between the system web applications to mobile phone clients.

6.2. THE PROTOTYPE

This prototype shows the system client side mobile interfaces that are accessed by the patient and web application interfaces which are used by healthcare workers and system administrators.

6.2.1. Mobile Phone Application

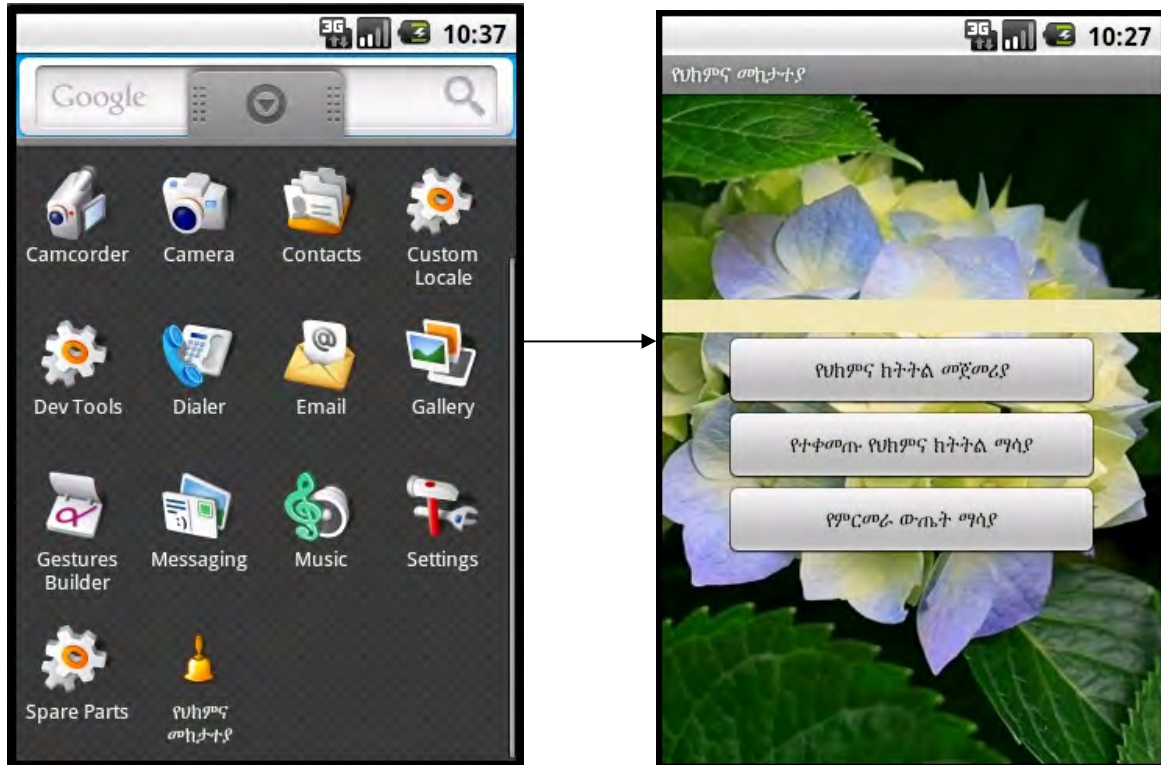

Figure 6.1: Main menu

The above figure shows an application icon inside android setting and the main menu of the system. The following figures show how patients communicate with health professionals using video data type procedure.



Figure 6.2: Application starter



Figure 6.3: Setting

The following figures show the steps how patients sent and received their health status using video data procedure.



The system checked that the patient is new. Then, patient fill first and last name.



The patient fills birth date, gender and captures his/her photo.



The patient records a video data (follow-up request) and checks the data. Then, the patient sends the data to the server.

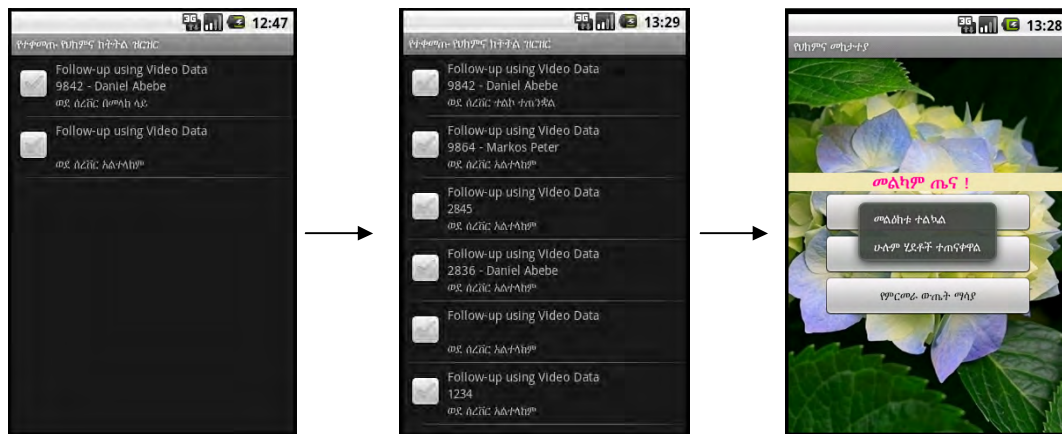

From this the patient can confirm whether the data is sent or not.

Figure 6.4: Follow up using video procedure

6.2.2. Diagnose Web Application

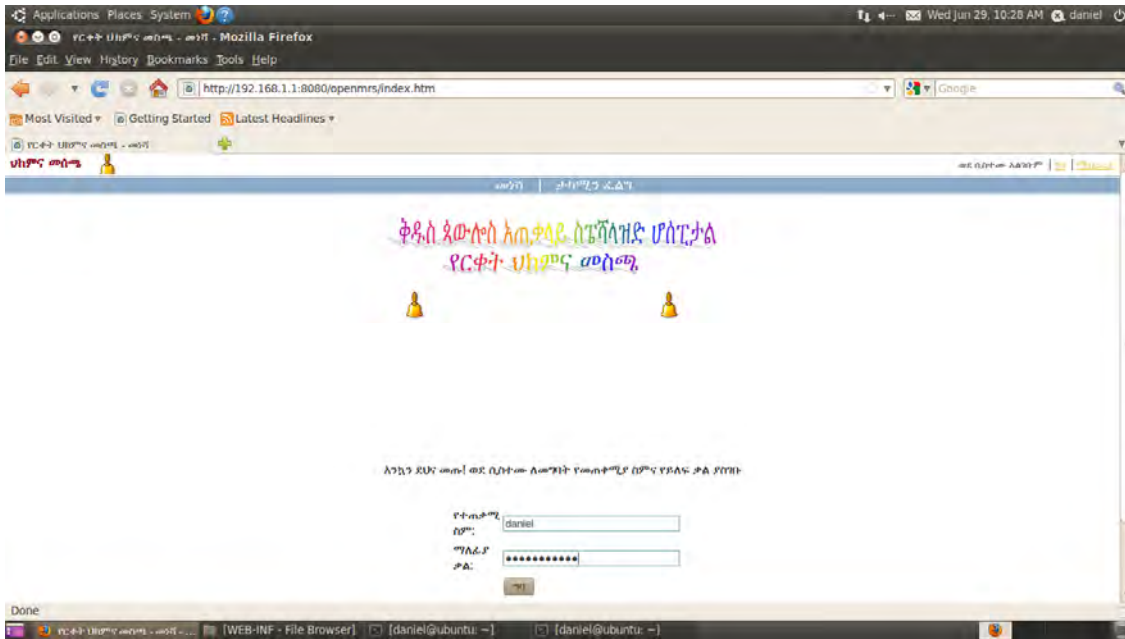

Figure 6.5: Login

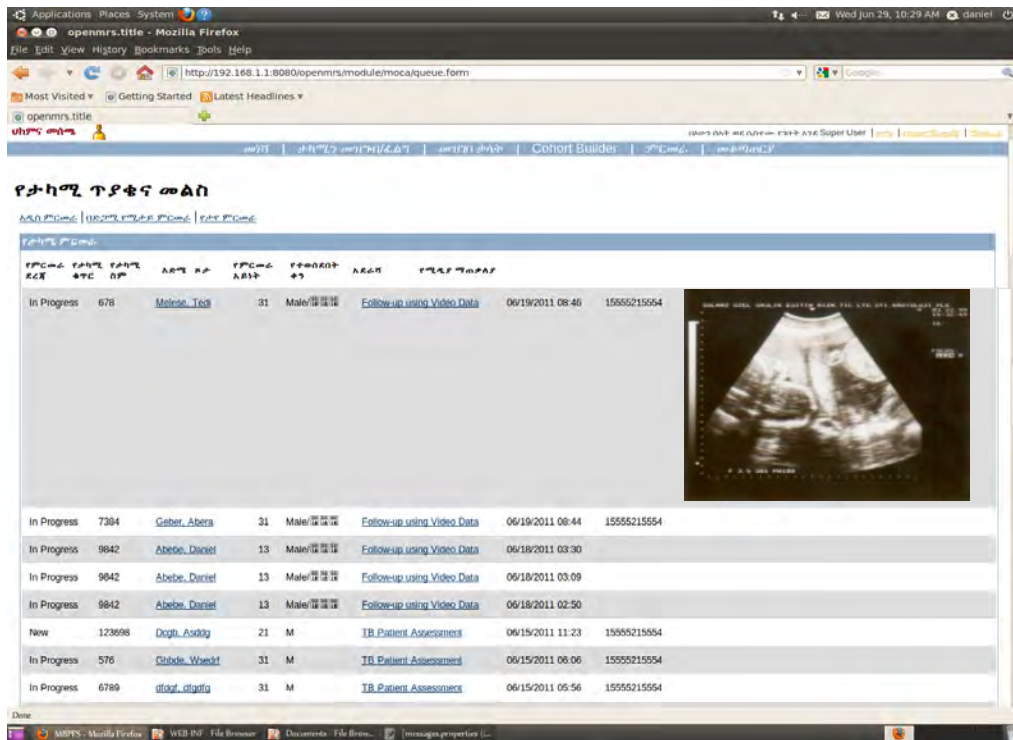

Figure 6.7: Patients' follow-up request queues



Figure 6.8: Diagnosis patient's follow-up request



Figure 6.9: Received diagnosis result

6.3. TESTING

The system is tested with different real data to meet the functional requirements which are identified in the requirement analysis. Moreover, this testing is used to find any kind of error that existed in the entire system development and to correct them.

Individual testing is used to test the functionality of each component (like Phone module, Diagnose Module and Dispatch Module). After this test, integration test is used to ensure the various components of the system that working together.

The Phone module is tested using android mobile phone. Where as, the Diagnose and Dispatch Module are tested using web browsers (Firefox 3.5, Google Chrome 4.1, and Internet Explorer 7)

The communication between the mobile phone application and the server has a fair response time even under slower Internet connection.

Finally, we demonstrated the system to the client (St. Paul's General Specialized Hospital) and we maintained the system based on their opinion and suggestion.

7. CONCLUSION

Nowadays, mobile technology is playing a pivotal role in improving provision of healthcare services and it has a positive impact on clinical outcomes such as reduced infant mortality, longer life spans and decreased contraction of disease. This would also enhance the possibility of increasing the efficiency and effectiveness of delivery of outpatient healthcare and decrease the substantial financial losses for healthcare systems.

In analyzing of the existing system, we found that healthcare organizations in Ethiopia are not enough to serve and give follow up services for the current population. They are not well organized, poor infrastructure, inadequate number of health professionals and deprived in health information technology. These lead to service delay, patient crowding, job dissatisfaction and inefficient, and patients need to travel a long distance for follow up.

Using this work, health professionals can provide continual follow-up for out-patients and records of critical data such as laboratory tests and medication. In addition, the system stops a patient from returning for follow-up in resource-poor environments and the frequent need for migration due to poverty and social disruption. Moreover, the system helps find missing patients and provide treatment, and failure to do so for HIV and TB is often a serious situation.

Form this study we found that in Ethiopia there is an opportunity to implement mobile health information technology using the current mobile signal coverage which has reached 64% of the total land area of the country and dynamic mobile phones distribution in the society. We believe that this work introduced and contributed an m-Health technology for:

- Public and private health organization to follow and recommend their patients while doctors are in office and patients stay in home.
- Patients to perform their follow-up activity and request their doctors when they need urgent assistant
- Health professionals who work in remote area to get expert advice from specialists.

This work is primarily focused on the offline follow up services for the out patients. The findings didn't consider the following issues and it will be considered as a future work.

- Online follow up system using text, audio, and video data.
- Integrating the system with patient monitoring devices to collect biological data and submit to the server without interference of a patient.
- Tracking patients online using their spatial data.

REFERENCE:

- [1] Rx for Healthcare IT. <http://www-01.ibm.com/software/tivoli/beat/08302006.html?ca=fromBeatRSS>, Last accessed: February 19, 2011
- [2] United Nations Department of Economic and Social Affairs, Division for Public Administration and Development Management, Compendium of ICT Applications on Electronic Government - Volume 1. Mobile Applications on Health and Learning (New York: United Nations, 2007).
- [3] Phoned pill reminders make inroads against TB. *The Nation* (Bangkok), January 28, 2007
- [4] Forjuoh, Samuel N., Michael D. Reis, Glen R. Couchman, and Marcia G. Ory. Improving Diabetes Self-Care with a PDA in Ambulatory Care. *Telemedicine and e-Health*. 14(3), April 2008.
- [5] Gebru, Berhane. Disease Surveillance with Mobile Phones in Uganda, <http://mobileactive.org/berhane-gebru-disease-surveillance-mobile-phones-uganda>, last accessed: February 20, 2011
- [6] Chen, Zhou-wen, Li-zheng Fang, Li-ying Chen, and Hong-lei Dai. Comparison of an SMS text messaging and phone reminder to improve attendance at a health promotion *R. Hewapathirana / Sri Lanka Journal of Bio-Medical Informatics 2010;1(1):120-23* 124center: A randomized controlled trial. *Journal of Zhejiang University Science*. 9(1), January 2008.
- [7] The Role of Mobile Phones in Increasing Accessibility and Efficiency in Healthcare. Moving the debate forward. The Vodafone Policy Paper Series, Number 4 (Newbury: Vodafone Group Plc, March 2006).
- [8] ZTE's End-to-End Project Delivery Solutions: Project-Oriented Network Planning and Design. http://www.zte.com.cn/endata/magazine/ztechnology/2010/no7/articles/201007/t20100715_187381.html, last accessed : February 19, 2011
- [9] Reithinger R, Megazzini K, Durako SJ, et al. Monitoring and evaluation of programmes to prevent mother to child transmission of HIV in Africa. *BMJ* Jun 2, 2007; 1143-1146.
- [10] Wools-Kaloustian K, Kimaiyo S, Diero L, et al. Viability and effectiveness of large-scale HIV treatment initiatives in sub-Saharan Africa: experience from western Kenya. *AIDS* Jan 2, 2006; 41-48.
- [11] Van Oosterhout JJ, Bodasing N, Kumwenda JJ, et al. Evaluation of antiretroviral therapy results in a resource-poor setting in Blantyre, Malawi. *Trop Med Int Health* May 10, 2005; 464-470
- [12] Jones SA, Sherman GG, Varga CA. Exploring socio-economic conditions and poor follow-up rates of HIV-exposed infants in Johannesburg, South Africa. *AIDS Care* May 17, 2005; 466-470.

- [13] Farmer P, Kim JY. Community based approaches to the control of multidrug resistant tuberculosis: introducing "DOTS-plus". *BMJ* Sep 5, 1998; 671-674 .
- [14] Mukherjee JS, Farmer PE, Niyizonkiza D, et al. Tackling HIV in resource poor countries. *BMJ* Nov 8, 2003 1104-1106 .
- [15] For Health Systems Trust, Nicholson J, McCoy D, Besser M, et al. Interim Findings on the National PMTCT Pilot Sites: Summary of Lessons Learned and Recommendations. Durban, South Africa: Department of Health; 2002. <http://www.hst.org.za/uploads/files/pmtctsummary.pdf>, last Accessed: October 09, 2010.
- [16] Haynes RB, McKibbin KA, Kanani R. Systematic review of randomised trials of interventions to assist patients to follow prescriptions for medications. *Lancet* 1996; 348: 383-386.
- [17] Disadvantages of SMS Text Messag, http://www.ehow.com/list_7160023_disadvantages-sms-text-messaging.html, last accessed February 24, 2011.
- [18] Mahmud N, Rodriguez J, Nesbit J., A text message-based intervention to bridge the healthcare communication gap in the rural developing world, *Technology Health Care*. 2010; 18(2):137-144.
- [19] TRACNET, [ww.un.org/esa/sustdev/publications/africa_casestudies/tracnet.pdf](http://www.un.org/esa/sustdev/publications/africa_casestudies/tracnet.pdf), last access February 23, 2011.
- [20] San Diego Project SHARE: Knowledge Bade ICT Application for Public Service, <http://www.voxiva.com/sandiego.asp>, last access February 23, 2011.
- [21] M. V. M. Figueredo, J. S. Dias "Mobile Telemedicine System for Home Care and Patient Monitoring" the 26th Annual International Conference of the IEEE EMBS San Francisco, CA, USA • September 1-5, 2004
- [22] "Smart Phones" for Older Chinese with Diabetes http://www.cadaproject.com/_data/Smart_Phones_for_Older_Chinese_with_Diabetes.pdf, last Accessed: October 09, 2010.
- [23] "Mashavu: Networked Health Solutions for the Developing", <http://live.psu.edu/story/29485>, <http://www.ideablob.com/ideas/1528-Mashavu-Networked-Health-Solu>, last Accessed: October 09, 2010.
- [24] "MediNet Healthcare Management System", <http://research.microsoft.com/en-us/events/mhealth2009/mohan-poster.docx>, last Accessed: October 09, 2010
- [25] "SIMpill Solution for TB", <http://www.SIMpill.co.uk>, <http://free.financialmail.co.zations/07/0302/minn.htm>, http://www.itweb.co.za/sections/computing_/2005/0501241215.asp?S=IT%20in%20Healthcare&A=ITH&O=TE, last accessed: October 09, 2010
- [26] Integrated Management of Childhood Illness (IMCI), http://www.who.int/entity/child_adolescent_health/documents/9789241597210/en/index.html, last accessed February 23, 2011

- [27] Sana Mobile, <http://www.sanamobile.org/about.html>, last accessed February 28, 2011.
- [28] Mobile data and Communication tools for Health, Agriculture, Conservatio, <http://datadyne.org/episurveyor>, last accessed February 23, 2011
- [29] ODK Clinic-view clinic data on a mobile phone: <http://code.google.com/p/opendatakit/wiki/ODKClinic>, last accessed February 23, 2011
- [30] Yam Anokwa, Carl Hartung et al, "Open Source Data Collection in the Developing World." IEEE Computer Megazine October 2009

APPENDIX

1. Amharic string for client application on the Android phone

```
<?xml version="1.0" encoding="utf-8"?>
<resources>
  <string name="hello">Hello</string>
  <string name="app_name">የህክምና መከታተያ</string>
  <string name="title_procedures_list">የመከታተያ አይነት ዝርዝር</string>
  <string name="title_savedprocedure_list">የተቀመጡ የህክምና ክትትል ዝርዝር</string>
    <string name="title_notifications_list">የምርመራ ውጤት ዝርዝር</string>
    <string name="title_settings">አቀማመጥ</string>
    <string name="title_upload_service">ወደ ሰርቨር መላኪያ አገልግሎት</string>
    <string name="button_main_new_encounter">የህክምና ክትትል መጀመሪያ</string>
    <string name="button_main_view_prior_encounters">የተቀመጡ የህክምና ክትትል
ማሳያ</string>
    <string name="button_main_view_notifications">የምርመራ ውጤት ማሳያ</string>

  <!-- General Phrases -->
  <string name="general_ok">አስማማለው</string>
  <string name="general_cancel">አልሰማማም</string>
  <string name="general_yes">አስማማለው</string>
  <string name="general_no">አልሰማማም</string>
  <string name="general_discard">ማሰገድ</string>
  <string name="general_alert">ማስጠንቀቂያ!</string>

  <!-- Dialog Strings -->
  <string name="dialog_already_uploaded">የህክምና መከታተያው ተልከል</string>
  <string name="dialog_exit_procedure">ይህን የህክምና መከታተያ ዝጋ</string>
  <string name="dialog_save_changes">ለውጥ መከተቻ</string>
  <string name="dialog_incorrect_credentials">መላክ አይቻልም፡ የሰረቨሩ መጠቀሚያ ስምና
ሚስጥር ቃል ተሳስቶል</string>

  <!-- Menu options strings -->
  <string name="menu_reload_db">ዳታቤዝ እንደገና መመያ</string>
  <string name="menu_settings">አቀማመጥ</string>
  <string name="menu_sync">ማናበቢያ</string>
  <string name="menu_save_exit">አስቀምጦ መውጣት</string>
  <string name="menu_discard_exit">ማሰገድ መውጣት</string>
  <string name="menu_jump_to_question">ቀጥታ ወደ ጥያቄ</string>

  <!-- Strings describing standard questions and common UI elements once
inside a Procedure -->
  <string name="next">ወደፊት</string>
  <string name="previous">ወደኋላ</string>
  <string name="question_standard_new_mrn">የታካሚ ቁጥር</string>
  <string name="question_standard_firstname">የታካሚ መጀመሪያ ስም</string>
  <string name="question_standard_lastname">የታካሚ መጨረሻ ስም</string>
  <string name="question_standard_birthday">የታካሚ ልደት</string>
  <string name="question_standard_month">ወር</string>
  <string name="question_standard_day">ቀን</string>
  <string name="question_standard_year">አመት</string>
  <string name="question_standard_gender">የታካሚ ፆታ</string>
  <string name="question_standard_male">ወንድ</string>
  <string name="question_standard_female">ሴት</string>

  <string name="procedurerunner_formdone">ተጠናቋል! ምን ማድረግ
ይፈልጋሉ?</string>
  <string name="procedurerunner_viewpagelist">ገጻችንን መመልከቻ</string>
  <string name="procedurerunner_goback">ወደኋላ</string>
  <string name="procedurerunner_upload">ማስቀመጫና ወደ ሰርቨር መላኪያ</string>
  <string name="procedurerunner_saveforlater">ወደፊት ለመላክ መክተቻ</string>
  <string name="procedurerunner_next">ወደፊት</string>
  <string name="procedurerunner_previous">ወደኋላ</string>
  <string name="procedurerunner_done">ተጠናቋል!</string>
  <string name="procedurerunner_scan_id">የታካሚ ቁጥርን ስካን</string>
```

```
<string name="question_for_fileupload">ከውጫዊ ዲቫስ ፋይል ማስገቢያ</string>
<string name="refresh_file_list">ፋይል ሪፍራሽ</string>
<string name="folder_is_empty">ፋይል ማስቀመጫው ባዶ ነው</string>

<string name="title_username">የመጠቀሚያ ስም</string>
<string name="title_password">የይለፍ ቃል </string>
<string name="button_login">መግቢያ</string>

<!-- Login Settings Strings -->
<string name="settings_mdurl_title">የሰርቨር አድራሻ</string>
<string name="settings_mdurl_summary">የሰርቨር አይፒ አድራሻ </string>
<string name="settings_hostname_title">የፕሮክሲ አድራሻ</string>
<string name="settings_hostname_summary">የፕሮክሲ አድራሻን ካስፈለገ ብቻ
አስገባ</string>
<string name="settings_port_title">የፕሮክሲ ፖርት</string>
<string name="settings_port_summary">የፕሮክሲ ፖርትን ካስፈለገ ብቻ አስገባ</string>

<string name="menu_exit">መውጫ</string>
</resources>
```

2. Dispatch implementation for web application on the system server

```
DEBUG = True
TEMPLATE_DEBUG = DEBUG

ADMINS = (
)

MANAGERS = ADMINS

DATABASE_ENGINE = 'mysql'      # 'postgresql_psycopg2', 'postgresql', 'mysql', 'sqlite3' or 'oracle'.
DATABASE_NAME = 'mds'         # Or path to database file if using sqlite3.
DATABASE_USER = 'root'        # Not used with sqlite3.
DATABASE_PASSWORD = 'newhope2011' # Not used with sqlite3.
DATABASE_HOST = ""           # Set to empty string for localhost. Not used with sqlite3.
DATABASE_PORT = ""           # Set to empty string for default. Not used with sqlite3.

# Local time zone for this installation. Choices can be found here:
# http://en.wikipedia.org/wiki/List_of_tz_zones_by_name
# although not all choices may be available on all operating systems.
# If running in a Windows environment this must be set to the same as your
# system time zone.
TIME_ZONE = 'America/Chicago'

# Language code for this installation. All choices can be found here:
# http://www.i18nguy.com/unicode/language-identifiers.html
LANGUAGE_CODE = 'en-us'

SITE_ID = 1

# If you set this to False, Django will make some optimizations so as not
# to load the internationalization machinery.
USE_I18N = True

# Absolute path to the directory that holds media.
# Example: "/home/media/media.lawrence.com/"
MEDIA_ROOT = '/opt/moca/media'

# URL that handles the media served from MEDIA_ROOT. Make sure to use a
# trailing slash if there is a path component (optional in other cases).
# Examples: "http://media.lawrence.com", "http://example.com/media/"
MEDIA_URL = '/mds/media'

# URL prefix for admin media -- CSS, JavaScript and images. Make sure to use a
# trailing slash.
# Examples: "http://foo.com/media/", "/media/"
```

```
ADMIN_MEDIA_PREFIX = '/mdu/media/admin'

# Make this unique, and don't share it with anybody.
SECRET_KEY = 'b#%x46e0f=jx%_#-a9b5(4bvxlz-obm*gs4iu3i6k!034j(mx'

# List of callable that know how to import templates from various sources.
TEMPLATE_LOADERS = (
    'django.template.loaders.filesystem.load_template_source',
    'django.template.loaders.app_directories.load_template_source',
    # 'django.template.loaders.eggs.load_template_source',
)

MIDDLEWARE_CLASSES = (
    'django.middleware.common.CommonMiddleware',
    'django.contrib.sessions.middleware.SessionMiddleware',
    'django.contrib.auth.middleware.AuthenticationMiddleware',
    'moca.mrs.util.LoggingMiddleware',
)

ROOT_URLCONF = 'moca.urls'

TEMPLATE_DIRS = (
    '/opt/moca/templates',
    # Put strings here, like "/home/html/django_templates" or "C:/www/django/templates".
    # Always use forward slashes, even on Windows.
    # Don't forget to use absolute paths, not relative paths.
)

INSTALLED_APPS = (
    'moca.mrs',
    'django.contrib.auth',
    'django.contrib.contenttypes',
    'django.contrib.sessions',
    'django.contrib.sites',
    'django.contrib.admin',
)

# OpenMRS URL (remember the trailing slash)
OPENMRS_SERVER_URL = 'http://192.168.1.1:8080/openmrs/'

# CLICKATELL_URI = "http://192.168.1.8/sms?phone=%p&text=%a"
# CLICKATELL_USER = 'kanneluser'
# CLICKATELL_PASSWORD = 'newhope2011'
# CLICKATELL_API = ""

# Kannel Settings
# TODO
KANNEL_URI = 'http://127.0.0.1:13013/cgi-bin/sendsms?%s'

# URI Example: 'http://127.0.0.1:13013/cgi-bin/sendsms?%s'

KANNEL_USER = 'kannel'
KANNEL_PASSWORD = 'kannel'

# Email Host
EMAIL_HOST = 'outgoing.mit.edu'
```

3. Kannel implementation for SMS gateway application using Sony Ericsson phone

```
#-----
# CORE
#
# There is only one core group and it sets all basic settings
# of the bearerbox (and system). You should take extra notes on
# configuration variables like 'store-file' (or 'store-dir'),
```

```
# 'admin-allow-ip' and 'access.log'

group = core
admin-port = 13004
smsbox-port = 13005
admin-password = bar
log-file = "/var/log/kannel/kannel.log"
box-deny-ip = "*"*.*.*)"
box-allow-ip = "127.0.0.1"
log-file = "/var/log/kannel/bearerbox.log"
access-log = "/var/log/kannel/access.log"
log-level = 0

#-----
# SMSC CONNECTIONS
#
# SMSC connections are created in bearerbox and they handle SMSC specific
# protocol and message relying. You need these to actually receive and send
# messages to handset, but can use GSM modems as virtual SMSCs

group = smsc
smc = at
modemtype = K530
device = /dev/ttyACM0
speed = 19200
my-number = +251913833917
validityperiod = 167

#-----
# SMSBOX SETUP
#
# Smsbox(es) do higher-level SMS handling after they have been received from
# SMS centers by bearerbox, or before they are given to bearerbox for delivery

group = smsbox
bearerbox-host = localhost
sendsms-port = 13013
global-sender = 13013
sendsms-chars = "0123456789 +-"
log-file = "/var/log/kannel/smsbox.log"
log-level = 0
access-log = "/var/log/kannel/access.log"

#-----
# MODEM SETUP
#
group = modems
id = K530
name = "Sony Ericsson"
detect-string = "K530"
init-string = "AT+CNMI=2,3,0,1,0;+CMEE=1"
message-storage = ME
keepalive-cmd = AT+CSQ
reset-string = AT+CFUN=1,0
speed = 115200

#-----
# SEND-SMS USERS
#
# These users are used when Kannel smsbox sendsms interface is used to
# send PUSH sms messages

group = sendsms-user
username = kannel
password = kannel
concatenation = true
#max-messages = 3
```

```
#-----  
# SERVICES  
#  
# These are 'responses' to sms PULL messages, i.e. messages arriving from  
# handsets. The response is based on message content. Only one sms-service is  
# applied, using the first one to match.  
  
group = sms-service  
keyword = default  
get-url = "http://localhost/kannel/receivesms.php?sender=%p&text=%b"  
accept-x-kannel-headers = true  
#max-messages = 3  
concatenation = true  
catch-all = true
```

Declaration

I, the undersigned, declare that this project is my original work and has not been presented for a degree in any other university, and that all source of materials used for the project have been duly acknowledged.

Declared by:

Name: _____

Signature: _____

Date: _____

Confirmed by Advisor:

Name: _____

Signature: _____

Date: _____