



ADDIS ABABA UNIVERSITY
SCHOOL OF GRADUATE STUDIES
ADDIS ABABA INSTITUTE OF TECHNOLOGY
SCHOOL OF ELECTRICAL AND COMPUTER ENGINEERING

**Shared Relay-Based Cooperative Communication with MIMO
Detection**

By

Abi Abate

Advisor

Dr. –Ing Dereje Hailemaraim

A Thesis Submitted to Addis Ababa University, School of Graduate Studies, Addis Ababa Institute of Technology, in Partial Fulfillment of the Requirements for the Degree of Masters of Science in Electrical Engineering

February, 2013
Addis Ababa, Ethiopia

ADDIS ABABA UNIVERSITY
SCHOOL OF GRADUATE STUDIES
ADDIS ABABA INSTITUTE OF TECHNOLOGY
SCHOOL OF ELECTRICAL AND COMPUTER ENGINEERING

**Shared Relay-Based Cooperative Communication with MIMO
Detection**

By

Abi Abate

Approval by Board of Examiners

Chairman, Dept. Graduate
Committee

Signature

Dr. –Ing Dereje Hailemaraim
Advisor

Signature

Internal Examiner

Signature

External Examiner

Signature

Declaration

I, the undersigned, declare that this thesis is my original work, has not been presented for a degree in this or any other university, and all sources of materials used for the thesis have been fully acknowledged.

Abi Abate

Name

Signature

Place: Addis Ababa

Date of Submission: _____

This thesis has been submitted for examination with my approval as a university advisor.

Dr. –Ing Dereje Hailemaraim

Advisor's Name

Signature

Acknowledgment

First and foremost, I would like to express my sincere gratitude to my respected advisor *Dr.-Ing. Dereje Hailemaraim* for his invaluable advice, incessant guidance and continuous encouragement throughout the course of my study and research. His plenty knowledge, rigorous working attitude and eagerness for new technology are always inspiring me as a model to follow in my future study and work.

As well, I would like to thank all the member of SECE for providing such an excellent education and research environment.

Finally, I would like to express my deepest appreciation to my family and colleagues. Their encouragement, support, and understanding through my work have meant more I can ever express.

Contents

Acknowledgment	i
List of Figures	iv
List of Tables	vi
Acronyms and Abbreviations	viii
Abstract	viii
1 Motivation and Background	1
1.1 Introduction	1
1.2 Problem Statement	3
1.3 Literature Review	5
1.4 Contributions	7
1.5 Objective of the Thesis	8
1.5.1 General Objective	8
1.5.2 Specific Objectives	8
1.6 Outline of the Thesis	9
1.7 Notations Used in the Thesis	9
2 Multiple-Input Multiple-Output Detection Techniques	11
2.1 Introduction	11
2.2 MIMO System Model	11
2.2.1 Spatial Diversity	13
2.2.2 Spatial Multiplexing	14
2.3 MIMO Detectors	14

2.3.1	Linear Detection Schemes	14
2.3.1.1	Zero Forcing	15
2.3.1.2	Minimum Mean Square Error	16
2.3.2	Non-linear Detection Schemes	17
2.3.2.1	Maximum Likelihood Signal Detector	17
2.3.2.2	Successive Interference Cancellation Detection	18
3	Cooperative Communication	22
3.1	Introduction	22
3.2	Principle of Cooperative Communication	23
3.2.1	Three-node Cooperative Communication	24
3.2.2	Four-node Cooperative Communication	25
3.3	Cooperative Relaying Protocols	27
3.3.1	Amplify-and-forward	28
3.3.2	Decode-and-forward	28
3.3.2.1	Fixed Protocols	28
3.3.2.2	Adaptive Protocols	29
4	Combing Techniques and Channel Model for Cooperative Diversity	30
4.1	Relaying Techniques	32
4.1.1	Superposition Modulation	32
4.1.1.1	AF-based Superposition	32
4.1.1.2	DF-based Superposition	33
4.1.2	Network Coding	34
4.2	Cooperative-MIMO Channel Model	35
4.2.1	Channel Model for Amplify-and-forward	35
4.2.2	Channel Model for Decode-and-forward	36
5	Simulation Results and Discussion	37
5.1	Results and Discussion	39
5.1.1	Symmetric Network Topology	39
5.1.1.1	Performance of Amplify-and-forward	40

5.1.1.2	Performance of Decode-and-forward	41
5.1.1.3	Amplify-and-forward versus Decode-and-Forward	42
5.1.2	Asymmetric Network Topology	43
5.1.2.1	Performance of Amplify-and-forward	44
5.1.2.2	Performance of decode-and-forward	47
5.1.3	Moving the relay	50
6	Conclusions and Recommendations for Future Work	53
6.1	Conclusions	53
6.2	Recommendations for Future Work	55

List of Figures

1.1	Communication in scattering environment.	2
1.2	Basic cooperative communications system with a single relay. . . .	4
1.3	Multiple access relay channel with sources ‘ S_1 ’ and ‘ S_2 ’, relay ‘ R ’, and destination ‘ D ’	5
2.1	Typical MIMO System with N_t transmitting antennas and N_r re- ceiving antennas.	12
2.2	Block diagram of linear detections schemes.	15
2.3	Illustration of V-BLAST detction process with MMSE and ZF de- tections.	20
3.1	Three node wireless relay system.	25
3.2	Multiple access relay channel with sources ‘ S_1 ’ and ‘ S_2 ’, relay ‘ R ’, and destinaion ‘ D ’	26
4.1	Two-source common relay and destination system model.	31
4.2	Network Coding-based realization of MARC.	34
5.1	Simulation setup.	38
5.2	Symmetric network topology.	39
5.3	BER performance of amplify-and-forward for different detection and combining.	41
5.4	BER performance of decode-and-forward for different detection and combining.	42
5.5	Comparative BER performance of amplify-and-forward and decode- and-forwad under MIMO detection.	43

5.6	Comparative BER performance of amplify-and-forward and decode-and-forward under MIMO-OSIC detection.	43
5.7	Asymmetric network topology.	44
5.8	BER performance of amplify-and-forward under asymmetric distribution and MIMO detection.	45
5.9	BER performance of amplify-and-forward under asymmetric distribution and MIMO-OSIC detection.	46
5.10	Average BER performance of amplify-and-forward under asymmetric distribution.	47
5.11	BER performance of decode-and-forward under asymmetric network and MIMO detection.	48
5.12	BER performance of decode-and-forward under asymmetric network MIMO-OSIC detection.	49
5.13	Average BER performance of decode-and-forward under asymmetric network distribution and MIMO detection.	50
5.14	BER contours for decode-and-forward with ML detection.	51
5.15	Three dimensional plot of the BER contours of decode-and-forward with ML detection.	52

List of Tables

5.1	Basic simulation parameters.	39
5.2	BER for AF relaying using symmetric and asymmetric	47

List of abbreviations

Abbreviation	Description
AWGN	Additive White Gaussian Noise.
BER	Bit error rate.
BPSK	Binary phase-shift keying.
BS	Base Stations.
CSI	Channel state information.
FEC	Forward error correction.
i.i.d	independent and identically distributed.
IDD	Iterative detection and decoding.
MARC	Multiple-access Relay channel
MIMO	Multiple-Input Multiple-Output.
ML	Maximum likelihood.
MMSE	Minimum mean-square error.
MMSE-SIC	Minimum Mean Square Error-Successive Interference Cancelation.
QPSK	Quadrature Phase Shift Keying.
SD	Spatial diversity.
SER	Symbol error rate.
SIC	Successive Interference Cancelation.
SINR	Signal to Interference plus Noise Ratio.
SM	Spatial multiplexing.
SNR	Signal-to-noise ratio.
V-BLAST	Vertical Bell-Labs layered space-time.
ZF	Zero-forcing.
ZF-SIC	Zero-Forcing Successive Interference Cancelation.

Abstract

The wireless channel places fundamental limitation on the performance of wireless communication network. Fading, path loss and shadowing are some of the impairments caused by the wireless channel, which result in significant performance degradation. These wireless channel impairments can be compensated by various ways such as by increasing transmit power or bandwidth.

Since these radio resources are scarce and expensive, future wireless systems should focus on new technologies that provide high spectral efficiency, high network coverage and improved link reliability. In this aspect, Multiple-Input Multiple-Output (MIMO) wireless communication system; where multiple antennas are equipped at the transceiver of the wireless link, has been considered as promising technology to meet these requirements.

However, due to size, cost, and/or hardware limitations, a small handheld wireless device may not be able to support multiple antennas. As a remedy to this problem cooperative communication, where nodes cooperate to create multiple antennas virtually, has been proposed recently. Although cooperative communication provide high network coverage and improved link reliability, the available relay resources are not fully exploited due to lack of optimal signal detection scheme.

To this end, this thesis presents a MIMO detection based cooperative wireless communication called multiple-access relay channel (MARC) and analyze the performance in the form of bit error rate (BER). It allows the receiver to jointly detect the source and relay transmissions, to provide better diversity gain. In MARC, multiple sources (two in our case) transmit to a common destination with the assistance of a single relay.

In this scenario, a network containing two sources, a common destination and a relay is analyzed. Two cooperative communication schemes which include amplify and forward and decode and forward employing different MIMO detection techniques are investigated and results obtained from simulations with respect to variable relay positioning are presented.

Keywords: Amplify-and-Forward, Bit-Error-Rate, MIMO Signal Detection, Cooperative Communications, Decode-and-Forward, Performance Analysis, Signal-to-Noise-Ratio, Wireless Networks, Superposition Modulation.

Chapter 1

Motivation and Background

1.1 Introduction

Wireless communication technologies have evolved to a more dynamic and vast applications in a couple of decades and are expected to continue in the future. Due to the rapid growth of multirate multimedia services, there is an even increasing demand for high data rates and more reliable transmission links. In order to meet these requirements, next generation wireless communication systems must employ advanced algorithms and techniques that not only increase the data rate, but also enable the system to guarantee the quality of service (QoS) desired by the various media classes [1].

However, unlike wired medium where it is stationary and predictable, the wireless channel is random and unpredictable. As depicted in Figure 1.1, the path between the transmitter and receiver can vary from a simple line-of-sight to the one that is severely obstructed by buildings, mountains, and the like, causing shadowing and multipath propagation. The interference between these multipath propagation, also called multipath waves, which may arrive at the receiver antenna with different phase and amplitude, causing *small-scale fading*. Small-scale fading is the rapid change of the instantaneous signal-to-noise ratio (SNR) over a short period of time or travel distance. These wireless channel impairments can severely affect the performance of wireless communication systems [1, 2, 3, 19].

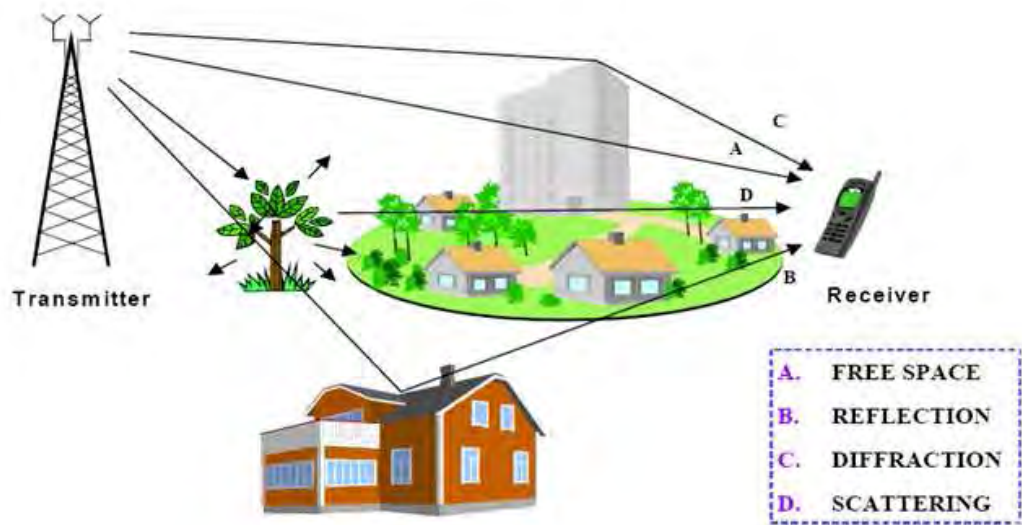

Figure 1.1: Communication in scattering environment.

These wireless channel impairments can be compensated by various ways such as by increasing transmit power or bandwidth, applying powerful error control coding. However, power and bandwidth are scarce and expensive radio resources while applying error control coding will reduce transmission rate [14].

Multiple-input multiple-output (MIMO) antenna systems have been considered as an efficient solution to tackle these wireless channel impairments by providing significant improvement in data rate and reliability over single antenna system. In contrast to traditional wireless systems in which there is one transmitting and one receiving antenna, MIMO systems use multiple antennas at both ends of the wireless link, all operating at the same frequency and at the same time providing significant multiplexing and diversity gains. Although MIMO systems are particularly advantageous for cellular base stations (BS), they may face limitations when it comes to their deployment in mobile terminals (MT) and sensor network due to size, cost, and/or hardware limitations [14].

In such cases, creating a virtual MIMO environment where nodes can collaborate and share their antennas to form a distributed virtual MIMO antenna system

is the easiest and most promising alternative to apply [17]. This is achieved by the so called *Cooperative diversity*. Cooperative diversity, which is one of the most effective ways to mitigate the fading effect of wireless channels in wireless network, is an alternative form of spatial diversity achieved through cooperative relaying [13]. Cooperative communication system, which is a new communication paradigm, is now receiving more and more attention as it can provide the advantages of MIMO communications systems like diversity without any physical antenna array [15, 16]. Recently, with the increasing demand in wireless communications the research on the cooperative diversity is absorbing a deal of attention [4].

The key idea in cooperation is to allow users to cooperate in transmitting their messages to the destination instead of operating independently and competing among each other for the common channel resources as done in conventional point-to-point networks. Consider the cooperative wireless communication system shown in Figure 1.2 where the source and relay nodes cooperate to deliver the source's data to a common destination node. All the nodes cannot simultaneously transmit and receive i.e., half-duplex. Time is considered slotted, and each source transmits in a dedicated time slot. Due to the broadcast nature of the wireless channel the relay also receives the source transmission. In the next time slot the relay may retransmit over statistically independent channel to the destination to provide redundant information; this can effectively avoid the uncertainty problem at the destination due to the spatial diversity. Spatial diversity is a powerful technique to combat the fading effect of the wireless channel [16]. However, the diversity gain is achieved at a cost of throughput as the source is not active for half of the time [1, 2, 4, 10].

1.2 Problem Statement

Despite the fact that cooperative communication enhances the network coverage and provide reliable link, there are challenges associated with this system. In traditional half-duplex relay schemes, the price to be paid for a cooperative di-

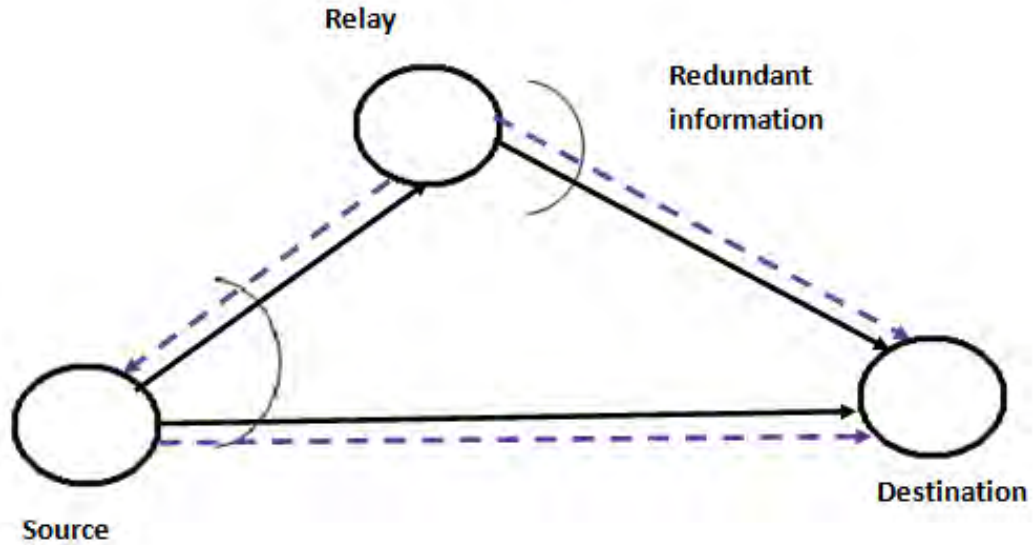

Figure 1.2: Basic cooperative communications system with a single relay.

diversity is a reduction in spectral efficiency compared to a system with co-located antennas (point-to-point transmission) due to the orthogonal time slot assigned for the relay. To increase spectral efficiency, different schemes have been studied for various relay networks and user cooperative networks, e.g. network coding and quadrature signaling [4, 9, 10].

Hence, the problem is to develop cooperative diversity schemes which makes possible to utilize relay resources more efficiently to increase spectral efficiency by allowing transmission to interfere. However, this in turn requires interference mitigation techniques at the receiver, which incurs additional complexity. In this regard, this thesis focuses on investigation of the attained performance improvement using MIMO detection based interference mitigation techniques. As depicted in Figure 1.3, the common relay combines all the relayed packets from each user into one packet, when doing this operation, additional interference is brought to the relayed information in the same time, and send it to the destination during the relaying phase. This can decrease the number of transmission by the relay from two, in traditional cooperative diversity, to one over single transmission cycle. A detection based on MIMO system are used at the destination to recover the original transmission.

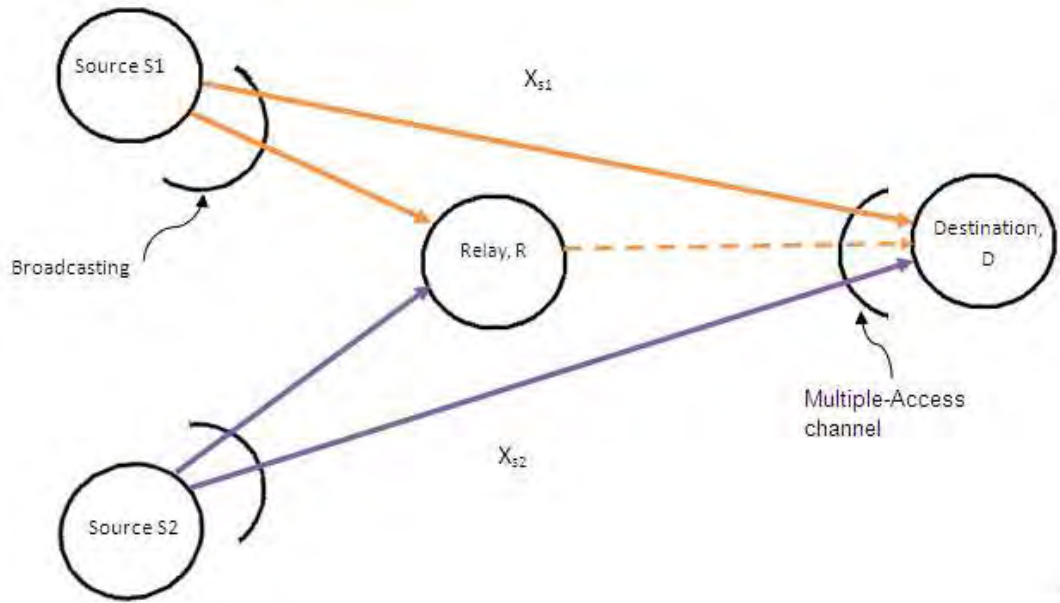

Figure 1.3: Multiple access relay channel with sources ‘ S_1 ’ and ‘ S_2 ’, relay ‘ R ’, and destination ‘ D ’

1.3 Literature Review

Because of its increase in link reliability and coverage range without expending additional bandwidth and transmit power, cooperative systems have got a wide research attentions in the last few years. Some of the researches conducted on the area of cooperative diversity systems and related to this work are briefly reviewed below.

The first breakthrough to cooperative systems was made by Sendonaris, et al. [1], where they analyzed the information theoretic capacity, outage, and coverage extension of cooperative diversity. They also hinted the potential benefits of co-operation.

Because of its advantage over conventional point-to-point communications as discussed above, the relaying concept has gained great attention in recent research [2-9]. Erik G. Larsson and Branimir R. Vojcic proposed a new cooperative transmission scheme based on *superposition modulation* and multiuser detection [2]. It was shown that within the same complexity, it can outperform classical decode-

and-forward cooperation scheme by about 1.5-2 dB in the SNR ranges of interest. As an extension to this, the achievable capacity region of this scheme was analyzed for both amplify-and-forward (AF) and decode-and-forward (DF) and the optimal superposition weight factor was derived in [3]. However, linear superposition modulation scheme was employed which is one dimensional superposition that linearly combines the two separated modulations. This brings additional interference to the local information in the same time and can degrade the system performance.

For a three node cooperative system, [4, 10] proposed a cooperative diversity scheme based on *orthogonal signaling*, where user's own and its partner's information are modulated to the in-phase and quadrature components of the QPSK signal constellation. In [4], the authors are concerned with fixed DF relaying instead of selection relaying, employing symbol-by-symbol detection without cyclic redundancy check (CRC) in the partner. Therefore, the diversity gain may be lost when the quality of inter-user channel is not good enough, and the performance may be even worse than that of the non-cooperative scheme under the same power and bandwidth consumption. As an extension to this, in [10], each user transmits its message frame-by-frame and selection DF relaying is adopted, where the user forwards the partner's message only if it has correctly decoded the message checked through CRC.

[5] proposed a network coding approach to a three-node cooperative diversity that makes an efficient use of resources. The authors considered two partners; cooperating in transmitting information to a single destination; each partner transmits both locally-generated information and relayed information that originated at the other partner. Even though this scheme provides substantial coding gain, it requires a higher inter user channel quality.

In [8], Rui Lin, et al., have proposed a cooperative transmission scheme for a MARC wireless network. At the common relay the data streams from both users are always decoded, interleaved and re-encoded regardless of their correctness.

It was shown that; the proposed scheme reduces the performance gap between different users having different channel conditions without degrading the performance of the user having good channel conditions. However, the diversity gain may be lost when the quality of source-relay channel is not good enough.

In [11], the authors propose *joint network-channel coding* for the MARC and investigate the system performance based on bit error rate (BER). Whether the two user's data are decoded without errors at the relay, the estimates of the information bits are jointly combined to form the network code bits and sent to the destination to provide additional error protection. But this can result in error propagation whenever the source-relay channels' quality is poor and can degrade the system performance. In [9], the authors analyzed the performance of MARC with network coding and non-ideal source-relay channels in the form of outage probability and coverage area. To avoid error propagation, the relay forwards the network-coded message only when both messages are correctly decoded and they analyze the performance in the form of outage probability and coverage area.

In the following section we will look at the difference between the above discussed literatures and this thesis work.

1.4 Contributions

In all the literatures seen so far in Section 1.3, cooperative communication has been investigated at various levels. However, some of the differences in the previous work and the current work are underlined in the following points.

- In this thesis, MIMO detection model for MARC which enables the receiver to jointly detect the source and relay transmissions are proposed. In MARC, multiple sources (two in our case) transmit to a common destination with the assistance of a single relay. The proposed scheme provide better diversity, since the detection techniques allow the relay to send data if at least either of the two source data are correctly decoded and the destination combine the direct and relay transmission before decoding/ making

hard decision. This enables if either of the two direct transmissions failed there will be a high probability that the incorrect symbol will be corrected by the signal from the relay when jointly detected at the destination and we believe such considerations were missing from previous work.

- The performance is analyzed and compared with different existing schemes in the form of BER. Simulation results show that the proposed model achieve better performance.
- The effect of the source-relay channel quality on the system performance is also investigated by setting different relay position and this is another major contribution of this thesis. Simulation results show that the average BER degrades when the relay located between source and destination, which attributes to the increase of the probability that the relay participates in cooperation and thereby improves the system performance.

1.5 Objective of the Thesis

1.5.1 General Objective

In general, the objective of this thesis is to study the performance of shared relay-based cooperative transmission protocols with multi-user interference detection schemes.

1.5.2 Specific Objectives

Specifically; the aim of this thesis is to:

- Study various cooperative protocols and signal combining techniques at relaying node.
- Review the conventional MIMO signal detection schemes and analyze their role in wireless network.
- Propose how existing MIMO detection techniques can be used in MARC cooperative transmission protocols.

- Evaluate and compare the BER performance and throughput enhancement of the proposed scheme.

1.6 Outline of the Thesis

In this thesis, conventional MIMO detection algorithms, i.e., linear and non-linear, are proposed and investigated based on their performance for a four node cooperative wireless communication. In addition, the performance of proposed system is compared with existing cooperative schemes considering variable relay position. The detailed outline are as follows.

- Chapter 2 discusses the conventional MIMO system model. It then introduce conventional MIMO signal detection algorithm.
- In Chapter 3, we introduce cooperative communications including the most commonly used cooperation strategy and describe the benefits that it holds for wireless networks. We then describe the proposed system model of this thesis.
- In chapter 4, a detailed investigation on the combining and detection techniques used in the thesis is provided.
- In Chapter 5, a simulation results of the system model considered in chapters three and four is provided. The simulation results are BER versus SNR characteristics, which are used to compare performance of the proposed model.
- Finally, in Chapter 6, we conclude based on the results obtained and recommendations to future works are given.

1.7 Notations Used in the Thesis

Throughout the thesis, the following notations are used. Matrices are represented by boldface and italic capital letters; vectors by boldface, italic lower case letters. The superscripts $(.)^T$, $(.)^H$ and $(.)^+$ stand for transpose, conjugate transpose and

pseudo-inverse respectively. $h_{i,j}$ stands for entry in the i^{th} row and j^{th} column of the matrix \mathbf{H} , and b_i for the i^{th} entry of vector \mathbf{b} . Likewise, \mathbf{I}_N denotes the $N \times N$ identity matrices.

Chapter 2

Multiple-Input Multiple-Output Detection Techniques

2.1 Introduction

In the previous chapter, introduction and literature review of works related to cooperative communication systems were briefly discussed. In this chapter, as one of the possible mitigation techniques of fading, a brief review of MIMO detection algorithms, spatial diversity (SD), and spatial multiplexing (SM) are presented.

The chapter is organized as follows. In Section 2.2 general description of MIMO system model and brief discussion of its operation principle are made; Sections 2.3 and 2.4 introduce linear MIMO detection techniques. Finally, in Section 2.5 nonlinear MIMO detection techniques are discussed briefly.

2.2 MIMO System Model

MIMO wireless antenna systems have been recognized as a key technology for future wireless communications [25]. MIMO systems were introduced in order to enhance the performance of the wireless communications systems to provide robustness, high data rates, and reliability by combating the channel fading with the use of multiple antennas [20, 21, 22]. MIMO systems provide redundancy

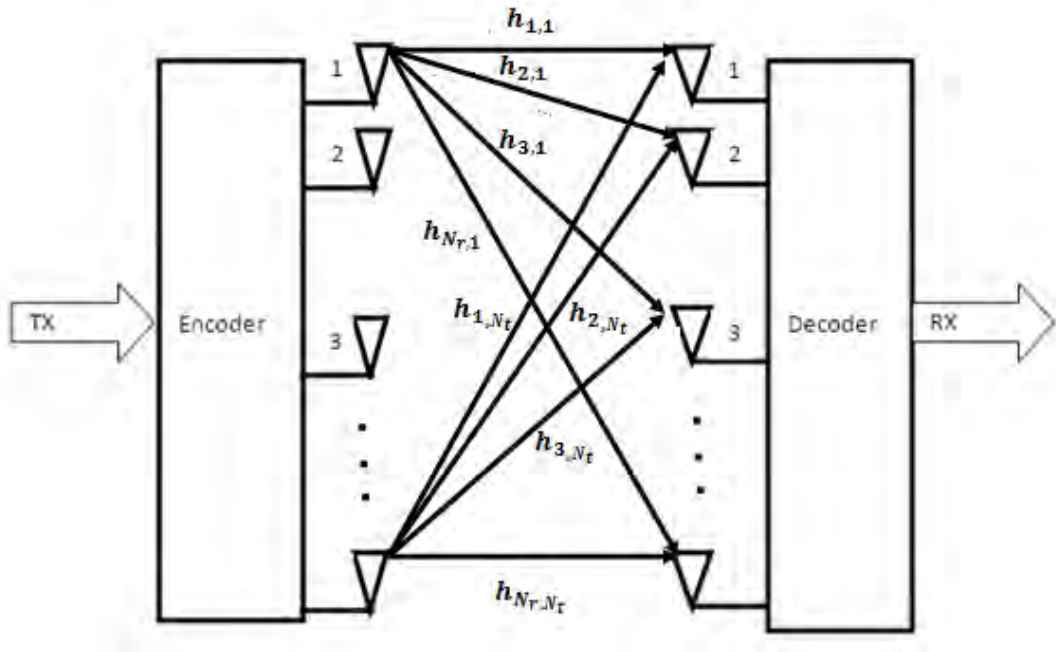

Figure 2.1: Typical MIMO System with N_t transmitting antennas and N_r receiving antennas.

through the multiple independent fading channels, which are created between the transmitting and the receiving antennas.

Figure 2.1 shows a schematic diagram of a typical MIMO system of with N_t transmitting antennas and N_r receiving antennas [22]. In such system, a signal can be carried through the $N_t \times N_r$ different independent channels that exist between the transmitter and the receiver.

In the Figure $h_{i,j}$ represents the fading channel between the j^{th} transmitting antenna and the i^{th} receiving antenna. Since the signals from all the transmit antennas are sent at the same carrier frequency, the i^{th} receive antenna will not only receive signals from the j^{th} transmit antenna, but also from all the N_t transmitters and this can be written as in the following equation.

$$y_i = \sum_{j=1}^{N_t} h_{i,j}x_j + n_i \quad (2.1)$$

In general, the received baseband signal can be model as [21].

$$\mathbf{y} = \mathbf{H}\mathbf{x} + \mathbf{n} \quad (2.2)$$

where $\mathbf{y} \in C^{N_r \times 1}$ and \mathbf{x} denotes the received complex signal vector whose element can be defined by, $\mathbf{y} = [y_1 \ y_2 \ \dots \ y_{N_r}]^T$ and an $N_t \times 1$ transmitted data vector, respectively. Furthermore, \mathbf{n} is an $N_r \times 1$ noise vector with each entry is a complex Gaussian noise with zero mean and a variance of $2\sigma^2$, and $\mathbf{H} \in C^{N_r \times N_t}$ is complex MIMO channel coefficients matrix defined by,

$$\mathbf{H} = \begin{bmatrix} h_{1,1} & h_{1,2} & \dots & h_{1,N_t} \\ h_{2,1} & h_{2,2} & \dots & h_{2,N_t} \\ \cdot & \cdot & & \cdot \\ \cdot & \cdot & & \cdot \\ \cdot & \cdot & & \cdot \\ h_{N_r,1} & h_{N_r,2} & \dots & h_{N_r,N_t} \end{bmatrix} \quad (2.3)$$

in which $h_{i,j}$ denotes the fading coefficient.

2.2.1 Spatial Diversity

Spatial diversity is a technique to fight against signal fading. If a radio signal is received through one channel in a deep fading environment, then there is a possibility of losing that signal. Diversity technique is required to improve system performance in the presence of fading channels. In this technique, signals are transmitted and received through a number of channels instead of only one channel. The main idea behind diversity is that when several copies of the same signals are passed through different channels there is high probability that some signals will undergo deep fading while the others may not, since each signal pass through different physical channels or paths. When these signals reach the receiver, there will be significant amount of energy to make a decision that what was actually sent. From Figure. 2.1, we can use the whole antenna at the transmitter to send same data, as far as the transmitting antenna are separated far enough from each other, the transmitted data can experience different fading.

2.2.2 Spatial Multiplexing

Spatial multiplexing is a technique used to increase data rates in wireless communications by transmitting independent data streams on the different antennas and over the same frequency band simultaneously. This is achieved by dividing the data stream and transmitting it through multiple independent fading channels. As can be seen from Figure 2.1, the whole transmitting antenna can be used to send different data stream. This can increase the data transmission rate at the price of increasing computational complexity at the receiver.

2.3 MIMO Detectors

As it has been discussed previously, the enriched capacity of the MIMO systems is a consequence of the fact that different signals are transmitted from different antennas at the same time slot sharing the same frequency band. However, since these transmitted signals travel through the wireless channel where they are linearly superimposed, the receiver must properly separate the signals. Such an operation is called *signal detection*, almost entirely determines achievable performance, and therefore it has been one of the most important issues in a multi-antenna system design. Many algorithms have been proposed in the literature to implement efficient and less complex MIMO receivers which are broadly classified into *linear* and *non-linear detection techniques* [21-24]. This section reviews some of the conventional MIMO signal detection algorithms assuming perfect CSI at the receiver.

2.3.1 Linear Detection Schemes

In linear signal detection algorithm all the transmitted signals are treated as an interference except for the desired signal from the target transmit antenna. The interference signals from all other transmit antennas are minimized or nullified in the course of detecting the desired signal from the target transmit antenna. The linear detector takes the received vector \mathbf{y} and multiply it by a filter matrix \mathbf{G} which is obtained from channel matrix \mathbf{H} and then followed by parallel decision

on all layers as shown in the block diagram of Figure 2.2 [22]. Mathematically, using the narrowband system Equation (2.2), the output of the detector \mathbf{x}_{est} can be expressed as:

$$\mathbf{x}_{est} = \mathbf{G}\mathbf{y} = \mathbf{G}(\mathbf{H}\mathbf{x} + \mathbf{n}) \quad (2.4)$$

where \mathbf{G} is the filter matrix obtained from the channel matrix \mathbf{H} and \mathbf{y} is the received data vector. Depending on the design of the filter matrix \mathbf{G} , linear detectors are further grouped into Zero Forcing (ZF) and Minimum Mean Square Error (MMSE) methods which are illustrated below.

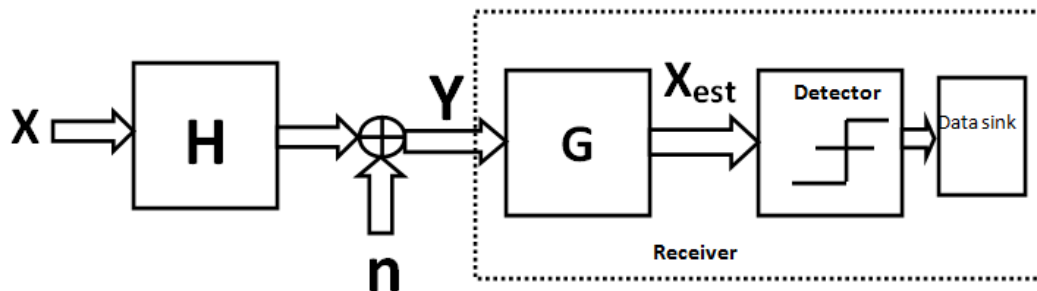

Figure 2.2: Block diagram of linear detections schemes.

2.3.1.1 Zero Forcing

It is a simple linear detector in which the mutual interference among the layers is perfectly suppressed. This is accomplished by the filter matrix \mathbf{G} chosen to totally eliminate inter-stream interference in \mathbf{x}_{est} which is given in the following equation.

$$\mathbf{G} = \mathbf{G}_{ZF} = \mathbf{H}^+ = (\mathbf{H}^H \mathbf{H})^{-1} \mathbf{H}^H \quad (2.5)$$

Where $(\cdot)^+$ represents a pseudo-inverse and $(\cdot)^H$ is the Hermitian transpose operator [19, 22]. Thus, the solution of the ZF is given by:

$$\mathbf{x}_{est} = \mathbf{G}_{ZF} \mathbf{y} = \mathbf{x} + \mathbf{G}_{ZF} \mathbf{n} = \mathbf{x} + \mathbf{w} \quad (2.6)$$

which is the transmitted data vector \mathbf{x} corrupted by the transformed noise $\mathbf{w} = \mathbf{G}_{ZF} \mathbf{n}$. This means that, the interference caused by the channel \mathbf{H} is completely removed or forced to zero. As can be seen from (2.6), the ZF detector suffers from noise enhancement, especially in the lower SNR range, as it tries to completely

null out the interference. The decision step consists of mapping each element of the filter output vector to the nearest constellation point by minimum distance quantization.

2.3.1.2 Minimum Mean Square Error

The MMSE detection method estimates the transmitted vector \mathbf{x}_{est} by minimizing the mean squared error between the actually transmitted symbol vector and the output of the linear detector. The MMSE receiver suppresses both the interference and noise components whereas the ZF receiver removes only the interference components. Hence, MMSE is superior to ZF detection in the presence of noise due to mitigating the noise enhancement [19]. The objective function of the MMSE MIMO detector can be derived as follow. The error between \mathbf{x} and \mathbf{x}_{est} can be given by

$$\mathbf{e}_{min} = \mathbf{x} - \mathbf{x}_{est} \quad (2.7)$$

Then the mean square error can be given by

$$\epsilon = E\|\mathbf{e}_{min}(\mathbf{e}_{min})^H\| \quad (2.8)$$

From the principle of orthogonality,

$$E\|\mathbf{e}_{min}(\mathbf{y})^H\| = E\|(\mathbf{x} - \mathbf{G}_{MMSE}(\mathbf{y}))(\mathbf{y})^H\| = 0 \quad (2.9)$$

Substituting for $\mathbf{y} = \mathbf{H}\mathbf{x} + \mathbf{n}$ and solving for for filtering matrix \mathbf{G} , leads to the MMSE solution matrix given by [21, 22, 23]

$$\mathbf{G} = \mathbf{G}_{MMSE} = (\mathbf{H}^H\mathbf{H} + \sigma^2\mathbf{I})^{-1}\mathbf{H}^H \quad (2.10)$$

where, $\sigma^2 = 1/SNR$ and $\mathbf{I} = N_t \times N_t$ identity matrix. Hence, the solution of the MMSE is given by:

$$\mathbf{x}_{est} = \mathbf{G}_{MMSE}(\mathbf{y}) \quad (2.11)$$

where, \mathbf{x}_{est} minimize the mean square error between transmitted and received data vector. From the MMSE solution matrix given in Equation (2.10) it can be observed that, at higher SNR values, i.e $\sigma \Rightarrow 0$, it is very close to the pseudo inverse of \mathbf{H} matrix, which is the ZF. On the other hand, for lower SNR values,

the solution is close to the \mathbf{H}^H , which is the Maximum Ratio Combination (MRC) or matched filtering. The MMSE method performs better than the ZF method by incorporating the noise term in its filter design.

2.3.2 Non-linear Detection Schemes

The linear detection schemes described earlier are viable in the sense of bit error rate (BER), but superior performance can be obtained by applying non-linear detection schemes. This section briefly reviews two of the non-linear schemes; namely, Maximum Likelihood (ML) and Successive Interference Cancellation (SIC) MIMO signal detection algorithms.

2.3.2.1 Maximum Likelihood Signal Detector

The ML detector performs optimum vector decoding and is optimal in the sense of minimizing the error probability [19]. This can be considered as the minimization of the squared Euclidean distance, where the received vector \mathbf{y} is compared with the entire possible transmitted vector (which is modified by the channel \mathbf{H}). Mathematically, the idea is to find a vector \mathbf{x}_k for which the conditional probability $P(\mathbf{x}_k/\mathbf{y})$ is maximized (with $1 \leq k \leq \mathbf{D}$), where \mathbf{D} denotes the ensemble of the possible transmitted vectors. Considering, a MIMO system with $(\mathbf{N}_t, \mathbf{N}_r)$ antenna configuration and employing \mathbf{A} -point constellation, $\mathbf{D} = \mathbf{A}^{N_t}$.

Using Baye's theorem, the probability density of the maximum a posteriori (MAP) equation $P(\mathbf{x}_k/\mathbf{y})$ can be written as [37]:

$$P(\mathbf{x}_k/\mathbf{y}) = \frac{P(\mathbf{y}/\mathbf{x}_k)P(\mathbf{x}_k)}{P(\mathbf{y})} \quad (2.12)$$

where, $P(\mathbf{y}/\mathbf{x}_k)$ is the conditional probability density function (pdf) of the received vector \mathbf{y} , given that \mathbf{x}_k is transmitted vector, $P(\mathbf{x}_k)$ is the probability of the k^{th} transmit vector. Consequently, finding the vector that maximizes $P(\mathbf{x}_k/\mathbf{y})$ is equivalent to finding the vector that maximizes $P(\mathbf{y}/\mathbf{x}_k)$. Thus, MAP transforms to maximum likelihood probability. Equation (2.12) can be manipulated

further and results in the maximum likelihood solution given below.

$$\mathbf{x}_{est} = \arg_{\mathbf{x}_k \in \mathcal{D}} \min \|\mathbf{y} - \mathbf{H}\mathbf{x}_k\|^2 \quad (2.13)$$

Where $\mathcal{D} = \mathbf{A}^{N_t}$ denotes the set of all possible transmitted data vectors and the minimization is performed over all possibly transmitted data vector \mathbf{x}_k .

Finding the maximum of the conditional probability, leads to minimization of symbol error, the ML is optimal in its error rate performance and it chooses the transmit symbol vector which minimizes the Euclidean norm between the received signal and all possible combinations of constellations from multiple antennas. The search space increases exponentially with number of antennas and the constellation size, it is computationally complex.

2.3.2.2 Successive Interference Cancellation Detection

The SIC is a non-linear MIMO detection scheme in which a linear detector is used to decode a stream and subtract it off from the received vector and detect the next stream and this process continues till all the data streams are detected. That is, the interference of the already detected signals is subtracted from the received signal \mathbf{y} before detecting the remaining signals. Thus, at each stage the number of interfering streams decreases. In this section SIC based on V-BLAST (Vertical Bell Labs Layered Space Time) approach is analyzed.

- **V-BLAST Detection**

V-BLAST MIMO architecture uses ZF or MMSE algorithms iteratively to perform symbol estimation [19]. In general, V-BLAST detection method involves, first determining filter matrix \mathbf{G} for ZF-based V-BLAST or MMSE-based V-BLAST then choosing the best channel based on post SNR or post signal-to-interference-plus-noise ratio (SINR), respectively. We need to utilize an ordering strategy in the V-BLAST system to combat the error propagation. An error in decoding the k^{th} data stream means that the subtracted signal is incorrect and this error propagates to all the streams further down. The order in which the streams are detected in the SIC impacts the performance as it might lead to error

propagation. Ordering is a method of easing the error propagation by sorting the order of the streams being detected based on SNR or SINR. Streams with higher post detection SNR or SINR may have lower error probabilities, thus processing these streams at earlier stages lead to less errors. The estimation errors of the different layers in the first detection step correspond to the diagonal elements of the error covariance matrix, which is equivalent to the covariance matrix of the noise after the filter, given by,

$$\phi_{ZF} = E[(\mathbf{x}_{est} - \mathbf{x})(\mathbf{x}_{est} - \mathbf{x})^H] = \sigma^2(\mathbf{H}^H \mathbf{H})^{-1} \quad (2.14)$$

$$\phi_{MMSE} = E[(\mathbf{x}_{est} - \mathbf{x})(\mathbf{x}_{est} - \mathbf{x})^H] = \sigma^2(\mathbf{H}^H \mathbf{H} + \sigma^2 \mathbf{I}_{N_t})^{-1} \quad (2.15)$$

Then, the corresponding element of \mathbf{x} is estimated and an estimate of the interference contributed by this data stream is calculated and subtracted from the received signal. The main drawback of the V-BLAST detection algorithms lies in the computational complexity, as it requires multiple calculations of the filter matrix [26]. The interference cancelled output signal is then used to detect the next strongest signal as illustrated in the following flow chart of Figure 2.4. The ZF V-BLAST scheme is an ordered SIC, which use ZF filter for detecting the streams and the ordering is based on the maximum post detection SNR using the error covariance matrix, $\sigma^2(\mathbf{H}^H \mathbf{H})^{-1}$.

The MMSE V-BLAST is an ordered SIC, in which the MMSE filter is used for detecting the streams and the ordering is based on the maximum post detection SINR. The stream which corresponds to the minimum value in the main diagonal of the error covariance matrix, $\sigma^2(\mathbf{H}^H \mathbf{H} + \sigma^2 \mathbf{I}_{N_t})^{-1}$ is detected first and the effect of that stream is removed from the received signal and process is iterated to get all streams [26]. In general, the V-BLAST detection method can be generalized with the following iterative steps:

1. Determine filter matrix \mathbf{G} based on Equation (2.5) or (2.10) for ZF based V-BLAST or MMSE based V-BLAST respectively.
2. Choose the best channel based on post SNR or post SINR for ZF V-BLAST or MMSE V-BLAST, respectively. This can be known from error covariance

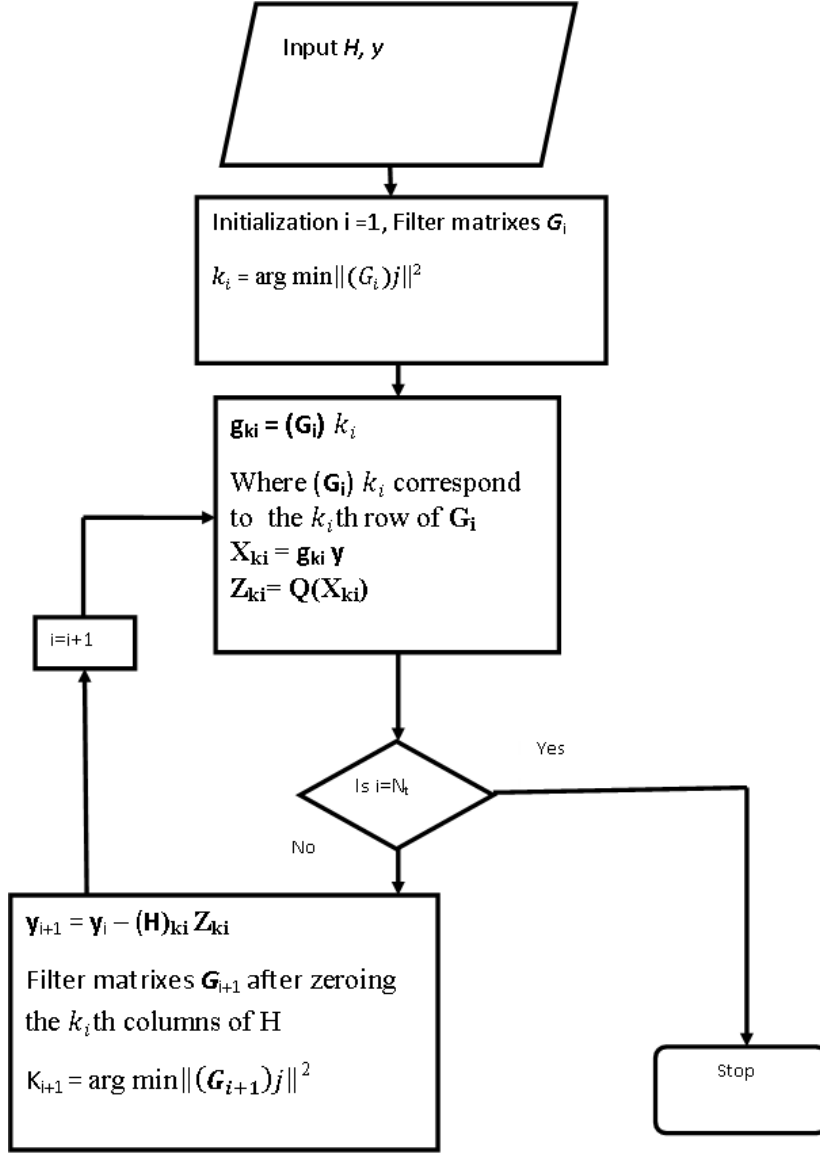

Figure 2.3: Illustration of V-BLAST detection process with MMSE and ZF detections.

matrices of Equation (2.14) or (2.15).

3. Estimate the corresponding element of \mathbf{x} using the i^{th} row of filter matrix \mathbf{G} as a nulling vector to get the corresponding element of \mathbf{x}_{est} (assuming that i corresponds to the row of the error covariance matrixes with minimum main diagonal element).
4. Map \mathbf{x}_{est} to the nearest constellation point using minimum distance quantization.

5. Cancel the interference of the estimated data stream from the received signal vector \mathbf{y} .

$$\mathbf{y}_{i-1} = \mathbf{y} - [\mathbf{H}]_i \mathbf{x}_{est} \quad (2.16)$$

Where $[\mathbf{H}]_i$ is i^{th} column of the channel matrix.

6. Go back to step one, but now by deleting the i^{th} column of the channel matrix \mathbf{H} which corresponds to the already detected symbol and replace \mathbf{y} by \mathbf{y}_{i-1}

Assuming correct previous decision at each layer, for the V-BLAST method, the diversity order of the stream increases in each stage and it is lower bounded by their corresponding diversity order obtained without interference cancellation $N_r - N_i + 1$.

Chapter 3

Cooperative Communication

3.1 Introduction

Wireless communications is currently a highly demanded communication technology that is most functional in terms of mobile access. Since its inception, it has gone through lots of developmental phases to meet the ever increasing needs of its wide range of applications. The multipath fading, shadowing, and path loss effects of wireless channels are the biggest challenges in the history of wireless communications which has induced considerable research for possible solutions. These effects cause random variations of channel quality in time, frequency, and space that make conventional wireline communication techniques too difficult to employ in the wireless environment. Hence, acquiring a high data rate, quality and reliable transmission, and coverage area over error prone wireless channel is a key ingredient for a wireless system designer.

The use of diversity technology highly improves the performance of wireless communications as it gives the signals a separate fading path during transmission to exploit diversity in different channel dimensions, such as time, frequency, and space, and hence achieve diversity gains. In particular, advances in the theory of MIMO systems have made it desirable to equip modern wireless transceivers with multiple antennas in order to achieve spatial diversity gains. MIMO system can overcome the limitations of wireless channels by providing diversity. Diversity

is an effective methodology for mitigating the impairment of a wireless network, which generally requires more than one antenna at the transceiver. As majority of the wireless devices (i.e., mobile handsets, sensor network, etc) are limited to only one antenna, especially due to hardware constraints, size and cost factors; cooperative communication can be utilized in order to generate diversity, increase system capacity and/or coverage area by communicating over a larger distance or around obstacles. The concept of cooperative communications is to exploit the broadcast nature of wireless networks where the neighbouring nodes overhear the source's signals and relay the information to the destination. Cooperation enables single antenna wireless terminal (cellular networks, sensor network and wireless ad hoc networks) to enjoy the spatial diversity benefit of MIMO. Hence, the key advantage of cooperation is that it enables a wireless network of relatively simple, inexpensive, single antenna devices to achieve the spatial diversity advantages of physical antenna arrays. Cooperative transmission provide a simple and effective way to achieve diversity gain for portable devices in wireless communication environment [6].

In this chapter, we examine cooperative diversity in fading wireless network, as it is an alternative solution to combat deleterious effect of fading. We will see that, cooperative diversity can improve outage performance in error prone wireless channel. In general this chapter will describe the common cooperative transmission protocols and the system model.

3.2 Principle of Cooperative Communication

The key idea behind cooperative communication is to allow users to help each other in transmitting each others' messages to the destination instead of operating independently and competing among each other for the common channel resources as done in conventional cellular networks. That is, one user overhears the partner transmission and then forward the received signal (using either amplify-and-forward or decode-and-forward) over statistically independent channel to the destination. As the same signals are transmitted to the destination over two

independently fading channels, this can overcome the problems of fading at the receiver. Multiple copies of the transmitted signals due to the cooperation among users result in a new kind of diversity, i.e., *cooperative diversity*, that can improve the reliability of the transmission. It has been shown that cooperative communications provide diversity gains in systems with limited numbers of transmit antennas through the use of relay nodes [8].

3.2.1 Three-node Cooperative Communication

A three node wireless relay system is depicted on Figure 3.1, where \mathbf{S} is the information source, the destination \mathbf{D} is the information sink and the relay \mathbf{R} is assisting the communication between \mathbf{S} and \mathbf{D} . Each mobile terminal has one antenna and cannot individually generate spatial diversity. However, it may be possible for one mobile to receive the other, in which case it can forward the overheard information. Because the fading paths from two mobiles are statistically independent, this can generate spatial diversity.

For a three node cooperative systems based on time division multiplexing [13, 18], the available time slots for each user (i.e., source and relay) are divided into two sub-slots: one for the direct and the other for the relayed transmission. The cooperative diversity gain usually comes at the price of decreasing bandwidth efficiency as the source is not active for half of the time. How to utilize the bandwidth more efficiently while maintaining the cooperative gain becomes an important system design issue. Several cooperative diversity systems based on various techniques, such as code superposition [5, 9, 11, 12, 31, 33], superposition modulation [2, 3, 7, 8] and quadrature modulation [4, 10, 32] have been proposed and analyzed. Due to the implementation simplicity and high bandwidth efficiency, quadrature modulation seems to be an attractive solution for practical applications[10].

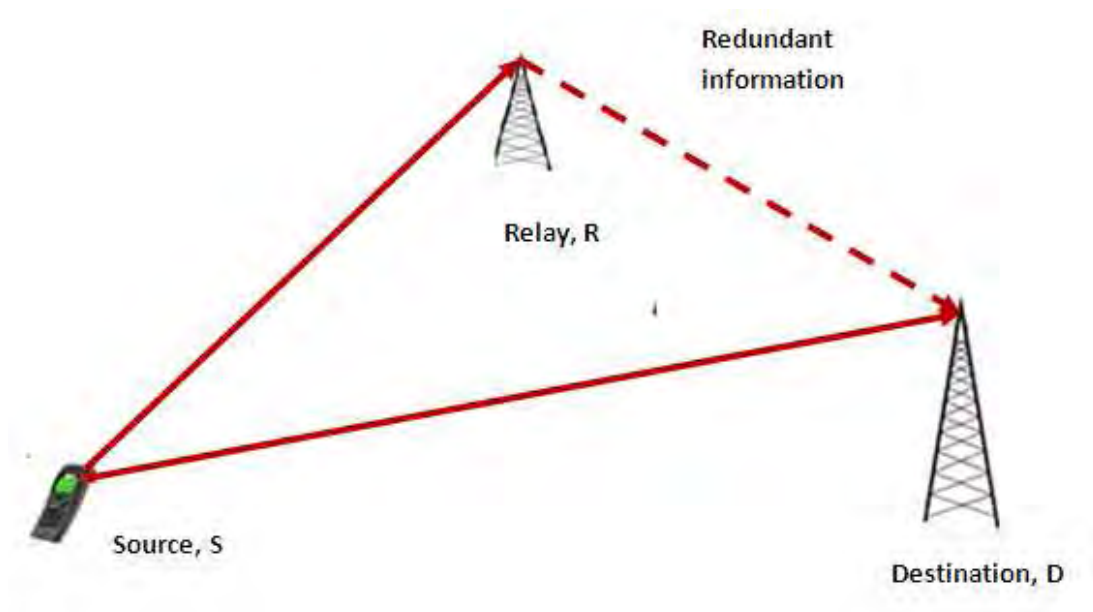

Figure 3.1: Three node wireless relay system.

3.2.2 Four-node Cooperative Communication

In this work in order to recover some of the throughput loss, still maintaining the diversity benefit, we have proposed MARC with MIMO detection at the receiver. MARC model not only provide reliable link but also improves the spectral efficiency of mobile radio networks [30]. A four node wireless relay system is depicted on Figure 3.2, where S_1 and S_2 are the information source, the destination D is the information sink and the common relay R is assisting the communication between the two sources and destination. Each mobile terminal has one antenna and cannot individually generate spatial diversity. An example of MARC is the cooperative uplink of two mobile stations with the assistance of a common relay to the base station in a cellular communication system.

As depicted in Figure 3.2, the common relay supports both sources in their transmission to the destination. After receiving the signals sent from each source, the relays forwards these information to the destination. The end-to-end transmission is clearly divided into two separate stages in the time domain: broadcasting and relaying phase. In the broadcasting phase, i.e., broadcasting channel as seen from the source's viewpoint, all the receiving terminals, the relays and destina-

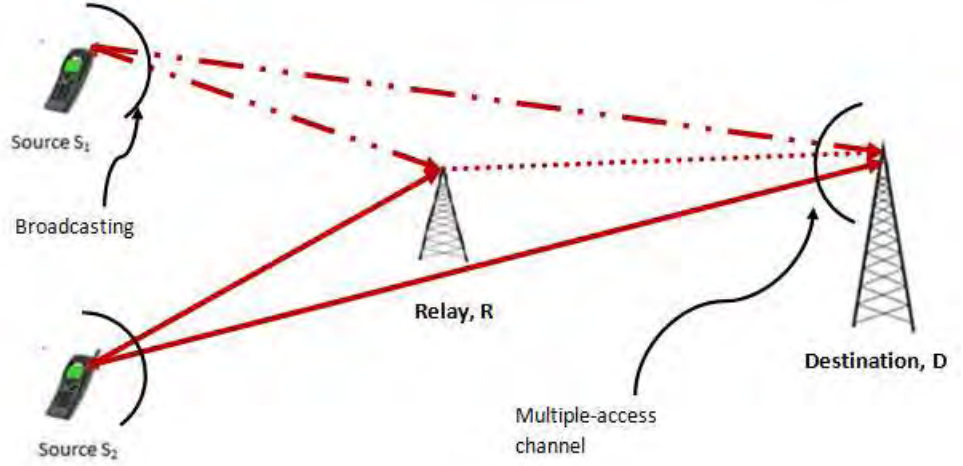

Figure 3.2: Multiple access relay channel with sources ‘ S_1 ’ and ‘ S_2 ’, relay ‘ R ’, and destination ‘ D ’

tion, work in the same channel. The broadcasting phase is further divided into two time slot, in the 1st time slot S_1 sends (broadcast) information to its destination, and the information is also received by the relay (due to broadcast nature of wireless channel) at the same time.

In the 2nd time slot S_2 broadcasts information to its destination and relay. In the relaying phase, the relay forwards the superimposed message, instead of two separate messages, still maintaining the diversity benefit, to the destination according to the implemented protocol. Thus, a network with this protocol transmits one packet from each user over three time slots. In the conventional MARC the relay would have transmitted each message independently, so that two orthogonal channels were required for relaying and four orthogonal channels for one cycle.

In order to get the maximum possible diversity gain, at the destination we have developed a MIMO detection model which enable us to *jointly detect* all the received signals.

During the broadcasting phase, the received signals at the destination and relay \mathbf{y}_{S_1D} , \mathbf{y}_{S_1R} , \mathbf{y}_{S_2D} and \mathbf{y}_{S_2R} due to S_1 and S_2 , respectively, can be written as [18]:

$$\mathbf{y}_{S_1D} = \mathbf{h}_{S_1D}\mathbf{x}_{S_1}(t) + \mathbf{n}_{S_1D} \quad (3.1)$$

$$\mathbf{y}_{S1R} = \mathbf{h}_{S1R}\mathbf{x}_{S1}(t) + \mathbf{n}_{S1R} \quad (3.2)$$

$$\mathbf{y}_{S2D} = \mathbf{h}_{S2D}\mathbf{x}_{S2}(t) + \mathbf{n}_{S2D} \quad (3.3)$$

$$\mathbf{y}_{S2R} = \mathbf{h}_{S2R}\mathbf{x}_{S2}(t) + \mathbf{n}_{S2R} \quad (3.4)$$

Where, $\mathbf{x}_{S1}(t)$ and $\mathbf{x}_{S2}(t)$ are the transmitted information symbols, and \mathbf{n}_{S1D} , \mathbf{n}_{S1R} , and \mathbf{n}_{S2D} , and \mathbf{n}_{S2R} are additive white Gaussian noise. Whereas, \mathbf{h}_{S1D} , \mathbf{h}_{S1R} and \mathbf{h}_{S2D} , and \mathbf{h}_{S2R} are the fading coefficient between the source and the relay and destination, and are modeled as quasi static rayleigh flat fading channel. It includes channel gain which is related to distance according to $1/d^v$, where v is the path-loss exponent. The distances between nodes ($S_n - D$, $S_n - R$ and $R-D$) are normalized against the longest distance, $d_{S_n-D}^{max}$, among all the distances so that $d_{S_n-D}^{max} = 1$.

For a distance d , between the source and destination, the channel mean power of the source-to-destination link is $\rho_{SD} = d^{-v}$ where the path-loss exponent $v = 3$ corresponds to a typical non line-of-sight propagation. Then, $\rho_{SR} = (d_{SR})^{-v}$ and $\rho_{RD} = (d_{RD})^{-v}$ are the channel mean powers of the source-to-relay and relay-to-destination links, respectively.

In the relaying phase, the relay forwards a processed version of the source's signal to the destination, and this can be modeled as:

$$\mathbf{y}_{rd} = \mathbf{h}_{rd}f(\mathbf{y}_{s1r}, \mathbf{y}_{s2r}) + \mathbf{n}_{rd} \quad (3.5)$$

Where the function $f(\cdot)$ depends on the processing scheme implemented at the relay node, i.e., amplify-and-forward or decode-and-forward.

3.3 Cooperative Relaying Protocols

The main idea behind cooperative communications is how the relay processes the source's signals, also called relaying protocol or processing mode at relays, and the destination combined with the direct transmission to provide full diversity. Recently, many efforts have also been focused on design of cooperative diversity

protocols in order to combat the effects of fading in wireless channels. This section will describe a variety of cooperative transmission strategies. These strategies employ different types of processing by the relay terminals.

3.3.1 Amplify-and-forward

In amplify-and-forward (AF) relaying strategies, the relay scales the received signal and retransmits it to the destination. At the destination, the direct and relayed signal are combined to provide diversity gain, which can mitigate the rapid fluctuation of instantaneous signal to noise ratio. In the AF cooperation systems, the relay amplifies not only the received signal, but also the noise, which affect system performance and is the main drawback of this protocol.

3.3.2 Decode-and-forward

With the decode-and-forward (DF) technique, the relay decodes the source's message, re-encodes and forwards it to the destination. Erroneous frames are not relayed since it would break down the performance at destination, but successfully decoded frames are re-encoded and forwarded to the destination. The destination receives the relayed signal and combines it with the direct path to provide diversity gain. Based on the level of adaptiveness to decoding errors, the relay can be operated either in a static/fixed or adaptive mode [9].

3.3.2.1 Fixed Protocols

In static mode, the relay decodes the messages received from the source and re-encode without checking their correct reception. Therefore, the diversity gain may be lost when the quality of source-relay channel is not good enough, and the performance may be even worse than that of the non-cooperative scheme under the same power and bandwidth [9]. The drawback of this approach is error propagation.

3.3.2.2 Adaptive Protocols

In adaptive mode, in order to avoid error propagation, the relay forwards the source message only if it has correctly decoded the message checked through CRC. If this is not the case, the relay remains silent. This technique provides more diversity gain at the expense of device complexity [4, 8, 9].

In the next chapter these relaying protocols are used to develop MIMO model for MARC cooperative communication, which enable the receiver to jointly detect the source and relay transmission. Joint detection allows the receiver to combine the source and relay transmission before making hard decision.

Chapter 4

Combining Techniques and Channel Model for Cooperative Diversity

This chapter discusses MIMO channel model of the proposed MARC cooperative wireless communication network that take into account system implementation constraints, such as orthogonal transmission. The orthogonal transmission constraint allows for the model to be easily integrated into existing networks. As discussed in the previous chapter, time division multiple-access (TDMA) with three timeslots are used to achieve the orthogonality.

Cooperative communication enables a single antenna terminal to enjoy spatial diversity gain through virtual antenna array. However, this gain is achieved at a cost of throughput. In order to recover some of the throughput loss, numerous schemes have been proposed in the literature. As an example MARC has been proposed in recent papers as a means to achieve diversity gain in wireless networks, at the same time reducing the number of transmissions by a relay node. In MARC, multiple sources transmit to a common destination with the assistance of a single relay as depicted in Figure 4.1. The chapter is organized as follows. Sections 4.1 discuss the combining scheme employed by the relay while in Section 4.2 MIMO channel model of the proposed system are discussed.

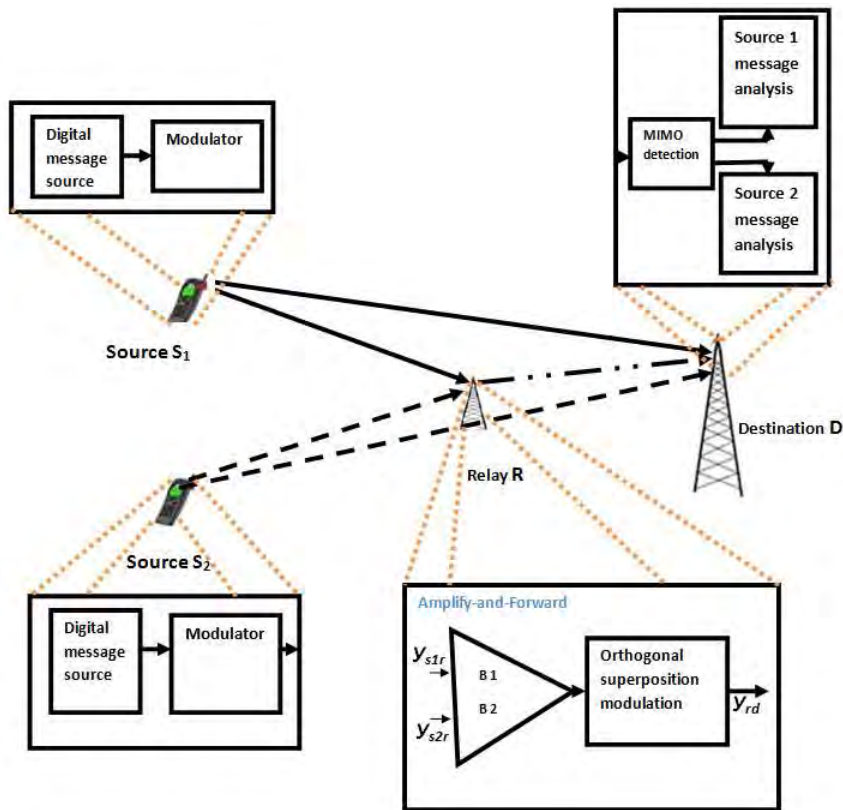

a) Overview of processing at the relay AF-based superposition.

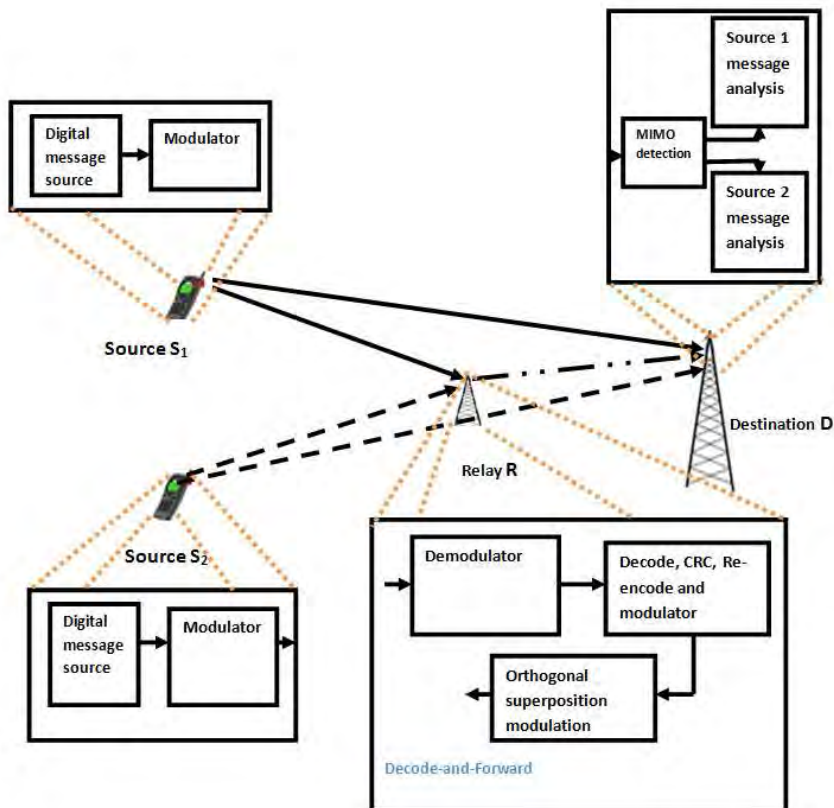

b) Overview of processing at the relay DF-based superposition.

Figure 4.1: Two-source common relay and destination system model.

4.1 Relaying Techniques

In this section various data merging schemes employed by relay are discussed. In conventional relaying schemes, the relay supports only one source at a time. On the other hand, in MARC, the relay supports multiple sources simultaneously. As depicted Figure 4.1, the relay transmits superimposed signals, received from the two user. This superposition can be performed in the code domain by a binary XOR operation [9, 12] or in the modulation domain by superposition modulations [2, 4, 8, 10]. The following sections discuss these two techniques in detail.

4.1.1 Superposition Modulation

It is cooperation scheme which allocate the source information to orthogonal axis, and generate a constellation similar with QPSK. This is achieved by transmitting in the in-phase and quadrature components of a phase shift keying modulation scheme. Many superposition strategies based on the relay channel have been proposed in the literature. In general, superposition modulation can be done in two categories: DF-based superposition and AF-based superposition.

4.1.1.1 AF-based Superposition

In this method the relay receives the signals transmitted by each source node and amplifies them in their noisy form (without performing any sort of decoding) to compensate the attenuation suffered in the source-to-relay links as shown in Figure 4.1(a). In doing so the noise in the signal is amplified as well, this is the main downfall of this protocol. The relay amplifies, combines and retransmit the users data using techniques known as orthogonal superposition modulation to the destination. This orthogonal superposition modulation can be considered as re-mapping the two users' data onto the in-phase and quadrature axes of an M^2 -QAM constellation, for each M-PAM constellation. Although the noise is amplified by the relay, the cooperation has been made at the destination by combining two independently faded signals resulting from source and relay. Hence, second order diversity can be achieved.

The power of the incoming signal from source at the relay $\mathbf{y}_{snr} = \mathbf{h}_{snr}\mathbf{x}_{sn}(t) + \mathbf{n}_{snr}$, for $n = 1, 2$, can be given by:

$$E\|\mathbf{y}_{snr}\|^2 = E\|\mathbf{h}_{snr}\|^2 E\|\mathbf{x}_{sn}(t)\|^2 + E\|\mathbf{n}_{snr}\|^2 \quad (4.1)$$

To send the data with the same power as the source power, the common relay has to use a gain of [18]:

$$\beta_1 = \sqrt{\left(\frac{p}{p\|\mathbf{h}_{s1r}\|^2 + N_o}\right)} \quad (4.2)$$

$$\beta_2 = \sqrt{\left(\frac{p}{p\|\mathbf{h}_{s2r}\|^2 + N_o}\right)} \quad (4.3)$$

Where β_1 and β_2 are scaling or amplifying factor for source one and two respectively and p is transmitted signal power and N_o is the noise power. Hence, the relayed user data can be given by the following equation [4].

$$\mathbf{x}_{rd} = \frac{1}{\sqrt{2}}(\beta_1\mathbf{y}_{s1r} + j\beta_2\mathbf{y}_{s2r}) \quad (4.4)$$

Where, \mathbf{y}_{s1r} and \mathbf{y}_{s2r} are user one's and user two's data received at the relay respectively.

4.1.1.2 DF-based Superposition

In this scheme, the relay decodes, re-encodes, modulates, and combines the two user data using orthogonal superposition modulation and transmits to the destination as shown in Figure 4.1(b). Due to the error propagation, the potentially wrongly decoded message at the relay can significantly degrade the system performance. Hence, the relays only assist direct communications if the signal from the source is correctly decoded. The detection of decoding errors is implemented by appending a frame check sequence (FCS), generated by a CRC code, to the transmitted information bits. With this assumption on the perfect capability of decoding by CRC, the relay can be considered as selective DF. The relayed user data can be given by the following expression.

$$\mathbf{x}_{rd} = \frac{1}{\sqrt{2}}(\mathbf{x}_{s1r} + j\mathbf{x}_{s2r}) \quad (4.5)$$

Where \mathbf{x}_{s1r} and \mathbf{x}_{s2r} are the relayed data for user one and user two, respectively.

4.1.2 Network Coding

The core notion of network coding is to allow intermediate nodes to combine data received from multiple links for subsequent transmission. In a network-coding-based realization of MARC, as shown in Figure 4.2, the relay forwards a network-coded message instead of two separate messages, still maintaining the diversity benefit [8, 9, 11]. Because the relay needs to combine the users' re-encoded packets, DF is used such schemes [8]. In order to avoid error propagation, the relay may check whether or not all the decoded packets are correct. It drops incorrectly decoded user packets and combines the remaining packets if more than one user's packet is successfully decoded.

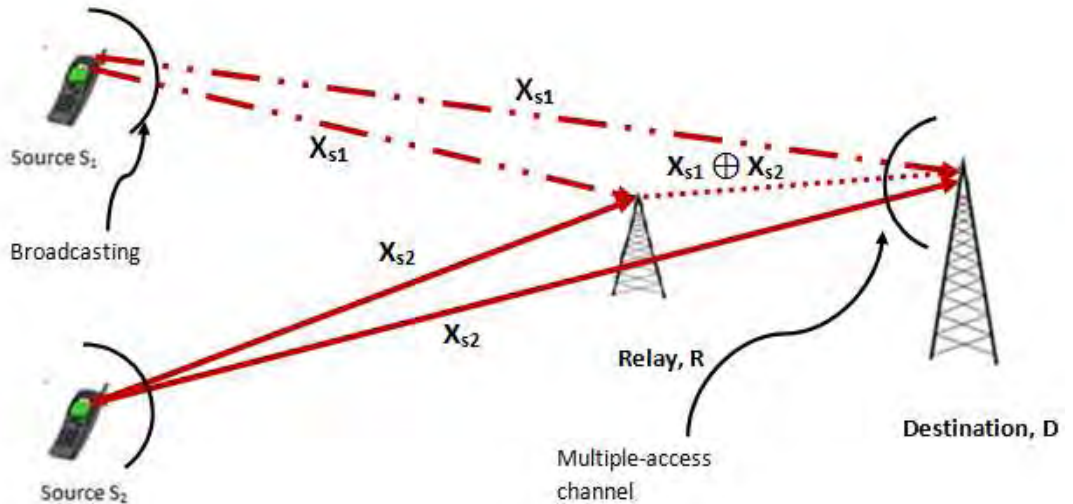

Figure 4.2: Network Coding-based realization of MARC.

In Figure 4.2, the relay forwards $\mathbf{x}_r = \mathbf{x}_{s1} \oplus \mathbf{x}_{s2}$, where the modulo-2 summation implements the network coding. In the conventional MARC the relay would have transmitted \mathbf{x}_{s1} and \mathbf{x}_{s2} independently; hence, two orthogonal channels were required. At the destination, users data can be recovered from either the direct transmission or by further network coding [9], e.g $\mathbf{x}_{s1} = \mathbf{x}_r \oplus \mathbf{x}_{s2} = (\mathbf{x}_{s1} \oplus \mathbf{x}_{s2}) \oplus \mathbf{x}_{s2}$. The same operation can be done to recover the message from source 2. Hence, one bit less has to be transmitted and we can therefore save one channel use. As explained before, in our proposed system, the destination combines the source

and relay transmission before making decision on the transmitted signal, this can improve the system performance.

4.2 Cooperative-MIMO Channel Model

This section develop the MIMO channel model of the system. An overview about the process at the destination is given in Figure 4.1. The destination is avail of three observations, two coming directly from the sources and one coming from the relay. The receiver employs MIMO detection to jointly detect the three observations and get the maximum diversity gain. The MIMO channel model of the proposed system for both combining techniques, namely amplify-and-forward and decode-and-forward, can be described as follow:

4.2.1 Channel Model for Amplify-and-forward

During amplify-and-forward, the signal received at the destination from relay for one complete cycle can be given by the following mathematical expression.

$$\mathbf{y}_{rd} = \mathbf{h}_{rd}(\beta_1 \mathbf{y}_{s1r} + j\beta_2 \mathbf{y}_{s2r}) + \mathbf{n}_{rd} \quad (4.6)$$

From Equation 3.2 and 3.4, $\mathbf{y}_{s1r} = \mathbf{h}_{s1r} \mathbf{x}_{s1}(t) + \mathbf{n}_{s1r}$ and $\mathbf{y}_{s2r} = \mathbf{h}_{s2r} \mathbf{x}_{s2}(t) + \mathbf{n}_{s2r}$ are the signal received form user one and two at the relay respectively. Substituting for \mathbf{y}_{s1r} and \mathbf{y}_{s2r} , \mathbf{y}_{rd} can be written as

- $\mathbf{y}_{rd} = \mathbf{h}_{rd} \beta_1 (\mathbf{h}_{s1r} \mathbf{x}_{s1}(t) + \mathbf{n}_{s1r}) + j \mathbf{h}_{rd} \beta_2 (\mathbf{h}_{s2r} \mathbf{x}_{s2}(t) + \mathbf{n}_{s2r}) + \mathbf{n}_{rd}$
- $\mathbf{y}_{rd} = \mathbf{h}_{rd} \mathbf{h}_{s1r} \beta_1 \mathbf{x}_{s1}(t) + j \mathbf{h}_{rd} \mathbf{h}_{s2r} \beta_2 \mathbf{x}_{s2}(t) + \mathbf{h}_{rd} \beta_1 \mathbf{n}_{s1r} + \mathbf{h}_{rd} \beta_2 \mathbf{n}_{s2r} + \mathbf{n}_{rd}$
- $\mathbf{y}_{rd} = \mathbf{h}_{rd} \mathbf{h}_{s1r} \beta_1 \mathbf{x}_{s1}(t) + j \mathbf{h}_{rd} \mathbf{h}_{s2r} \beta_2 \mathbf{x}_{s2}(t) + \mathbf{w}$

Where $\mathbf{w} = \mathbf{h}_{rd} \beta_1 \mathbf{n}_{s1r} + \mathbf{h}_{rd} \beta_2 \mathbf{n}_{s2r} + \mathbf{n}_{rd}$ is the transformed noise, and β_1 and β_2 are the amplifying gain for user one and two respectively. Whereas, h_{rd} is the channel fading coefficient between relay and destination. From Equation 3.1, 3.3 and 4.6, for amplify-and-forward relaying protocol, the simplified equivalent channel model can be given by:

$$\mathbf{y} = \mathbf{H}_{af} \mathbf{x} + \mathbf{n} \quad (4.7)$$

where $\mathbf{y} = [\mathbf{y}_{s1d} \ \mathbf{y}_{rd} \ \mathbf{y}_{s2d}]^T$ and $\mathbf{x} = [\mathbf{x}_{s1} \ \mathbf{x}_{s2}]^T$ are the received signal vector and transmitted signal vector, respectively;

$\mathbf{n} = [\mathbf{n}_{s1d} \ \mathbf{n}_{rd} \ \mathbf{n}_{s2d}]^T$ is the noise vector; and \mathbf{H}_{af} is the 3x2 channel matrix which represent

$$\mathbf{H}_{af} = \begin{bmatrix} \mathbf{h}_{s1d} & 0 \\ \beta \mathbf{1} \mathbf{h}_{rd} \mathbf{h}_{s1r} & j \beta \mathbf{2} \mathbf{h}_{rd} \mathbf{h}_{s2r} \\ 0 & \mathbf{h}_{s2d} \end{bmatrix} \quad (4.8)$$

4.2.2 Channel Model for Decode-and-forward

From Equation (4.5) during decode-and-forward, the signal received at the destination from the common relay for one complete cycle can be given by the following mathematical expression.

$$\mathbf{Y}_{rd} = \mathbf{h}_{rd}(\mathbf{x}_{s1} + j\mathbf{x}_{s2}) + \mathbf{n}_{rd} \quad (4.9)$$

Thus, from Equation 3.1, 3.3 and 4.9, for the case of decode-and-forward superposition modulation, the simplified equivalent channel model can be given by:

$$\mathbf{y} = \mathbf{H}_{df}\mathbf{x} + \mathbf{n} \quad (4.10)$$

where $\mathbf{y} = [\mathbf{y}_{s1d} \ \mathbf{y}_{rd} \ \mathbf{y}_{s2d}]^T$ and $\mathbf{x} = [\mathbf{x}_{s1} \ \mathbf{x}_{s2}]^T$ are the received signal vector and transmitted signal vector, respectively;

$\mathbf{n} = [\mathbf{n}_{s1d} \ \mathbf{n}_{rd} \ \mathbf{n}_{s2d}]^T$ is the noise vector; and \mathbf{H}_{df} is the 3x2 channel matrix which represent

$$\mathbf{H}_{df} = \begin{bmatrix} \mathbf{h}_{s1d} & 0 \\ \mathbf{h}_{rd} & j\mathbf{h}_{rd} \\ 0 & \mathbf{h}_{s2d} \end{bmatrix} \quad (4.11)$$

In the next chapter based on Equation (4.8) and (4.11) channel model of the proposed system, MIMO detection algorithms and transmissions protocols are compared with each other to determine, which detection results in a good performance. In a third part, the effect of the position of the relay station is presented.

Chapter 5

Simulation Results and Discussion

In this chapter, BER simulation results are presented. In the first part, it is assumed that both user (S_1 and S_2) have an equal distance from the common relay and the destination and therefore the same path loss and average SNR is assumed. With this equidistant arrangement the different detection and relaying types are compared to see their advantages and disadvantages. In the second part, S_1 is closer to both relay and destination than S_2 and therefore S_1 has less path loss and better average SNR as compared to S_2 . With this asymmetric arrangement the different detection and relaying types are compared to see their advantages and disadvantages. In the third part, the location of the relay station is varied to see the effect on the performance for different locations of the relay.

In all simulations, the channel is assumed to be perfectly known at the receiver. The BER performance is obtained by averaging over 60,000 channel realizations and unless otherwise mentioned, for a packet length of 50 bits per channel realization. Figure 5.1 shows basic simulation set up for the computation of BER in proposed systems. The physical layer parameters used in simulation are given in Table 5.1.

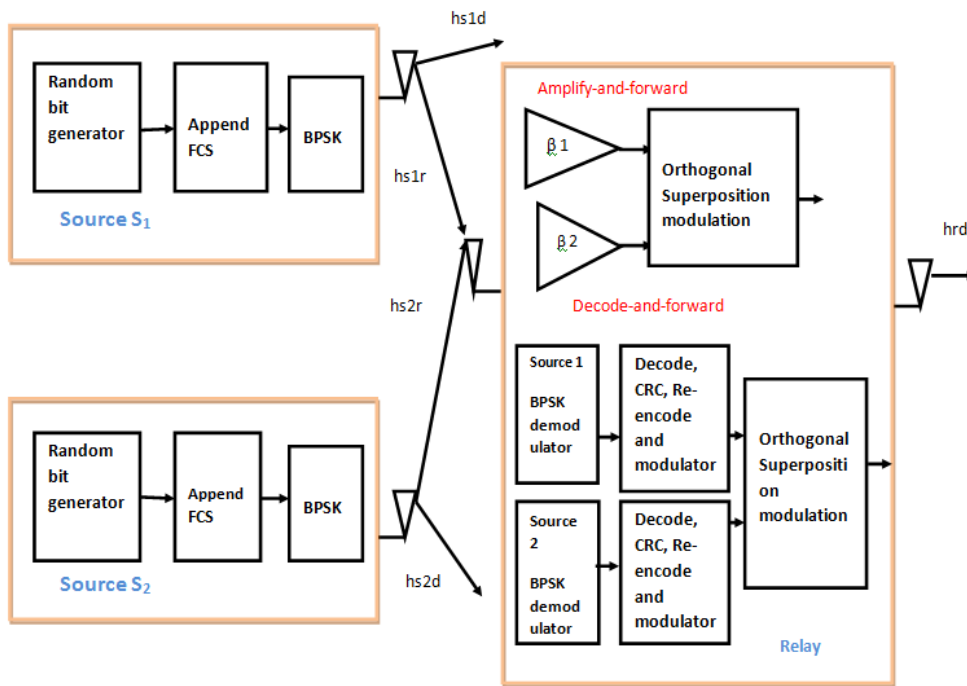

a) Source and relay block diagram.

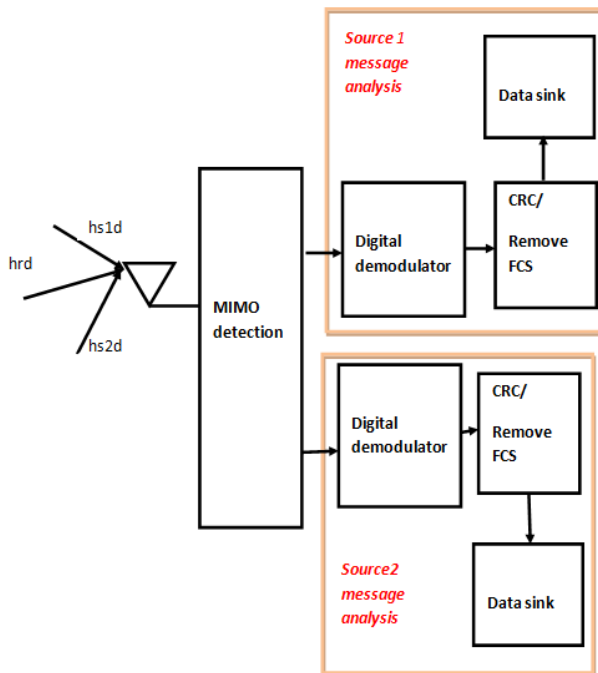

b) Destination block diagram.

Figure 5.1: Simulation setup.

Table 5.1: Basic simulation parameters.

MIMO Detection	ZF, MMSE, ML, V-BLAST.
Relay	Based on amplify-and-forward and decode-and-forward.
Modulation type	BPSK, QPSK.
Noise	Additive White Gaussian Noise.
Fading	Quasi-static Rayleigh flat fading channels.
Performance Metrics	BER.
Packet size	50 bits.

5.1 Results and Discussion

In this section, several numerical examples are presented to illustrate the performance of our proposed scheme. For simplicity, first we consider symmetrical network where both user suffer the same BER.

5.1.1 Symmetric Network Topology

Symmetric network topology is where the relay is positioned at an equal distance from the two sources and destination, i.e., $d_2 = d_3 = d_5$ and $d_1 = d_4 = 1$. This means that both the direct channels will have the same path loss and therefore the same average SNR.

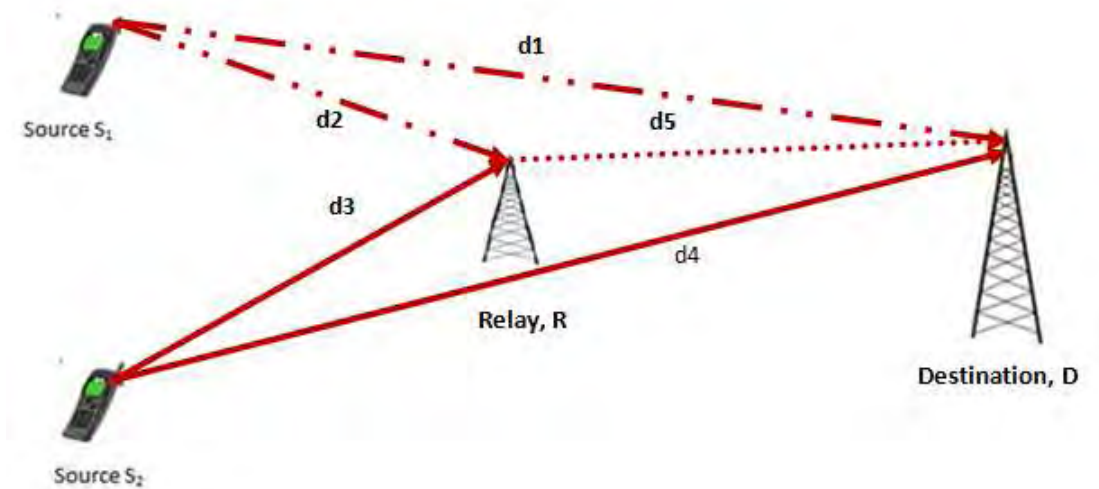

Figure 5.2: Symmetric network topology.

5.1.1.1 Performance of Amplify-and-forward

Figure 5.3 shows the average BER characteristics of amplify-and-forward under different detection and combining techniques against SNR. To verify simulation result, analytical plots are included. It is clear to see that, simulated BER curves have captured the analytical values thereby verifying the credibility of simulation results. The closed form BER expressions for SISO in BPSK modulation are given as [38]:

$$BER_{SISO} = \frac{1}{2} \left(1 - \sqrt{\frac{SNR}{1 + SNR}} \right) \quad (5.1)$$

The single link transmission should demonstrate if there is any benefit at all using diversity. The first pleasant result is that whatever detection type is used, the AF diversity protocol achieves a benefit compared to the direct link. But compared to the two senders link, AF diversity protocol achieves good performance under the proposed MIMO detection.

From Figure 5.3, it can be seen that the linear detection schemes (ZF and MMSE) have the poorest performance among the MIMO detection techniques. The ZF has the poorest performance due to error amplification in its detection process and the MMSE improves this performance by suppressing the error amplification. Another reason for poor performance of the linear detection schemes is that these methods have lower diversity order. The other important point worth observing from Figure 5.3 is that the performance of the ML detection methods, which has high complexity, shows approximately the same performance as MMSE based on V-BLAST and is just about 1dB better than the one using ZF based on V-BLAST. This means that the interference introduced by the relay small and allow to achieve a comparable performance as of ML.

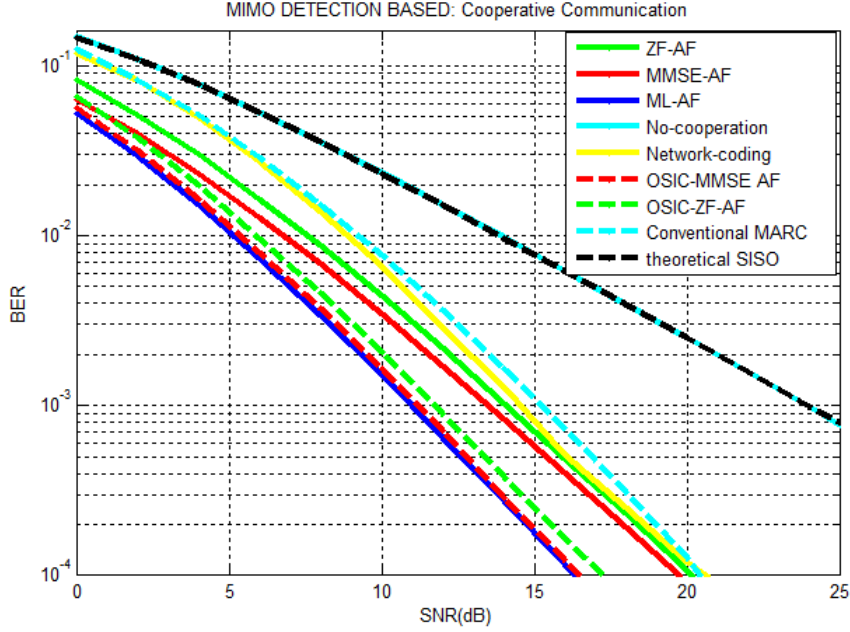

Figure 5.3: BER performance of amplify-and-forward for different detection and combining.

5.1.1.2 Performance of Decode-and-forward

The simulation results obtained by applying decode-and-forward relaying under the same detection techniques as for amplify-and-forward is shown in Figure 5.4. The first important point from Figure 5.4 is that DF diversity protocol achieves good performance under the proposed MIMO detection. This is because the joint MIMO detection allows getting maximum possible diversity gain from relayed transmission.

The next thing that attracts attention is the same performance of the nonlinear detections and the linear MMSE detection. The nonlinear detections, which are computationally complex, have no performance gain as compared to MMSE detection and therefore should not be used at all.

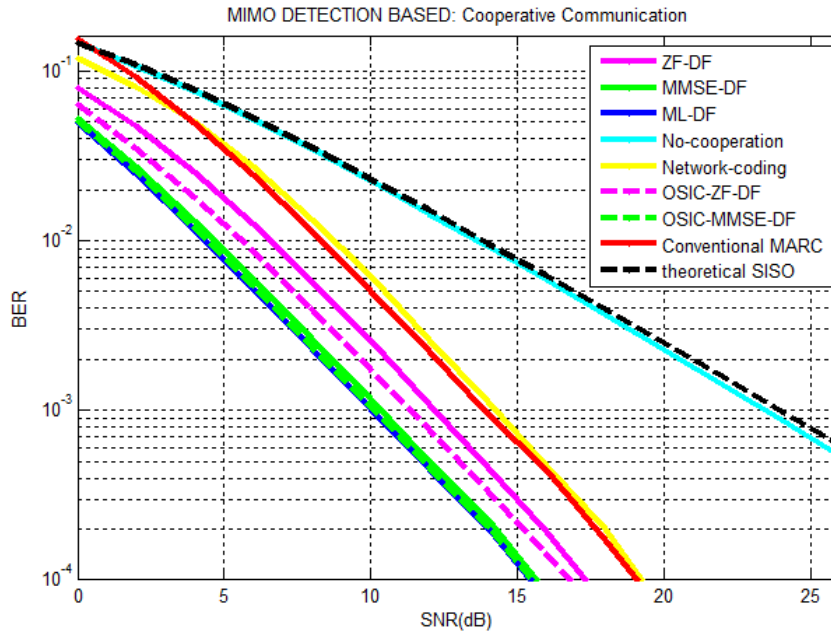

Figure 5.4: BER performance of decode-and-forward for different detection and combining.

5.1.1.3 Amplify-and-forward versus Decode-and-Forward

Figure 5.5 and 5.6 illustrates the performance of the AF diversity protocol compared with the DF protocol. It is clear to see that the DF diversity protocol always results in a better performance than the AF protocol whatever detection type is used for higher SNR at the expense of device complexity. This is due to the presence of amplified noise in the transmitted signal with regards to the AF protocol. Recall that this protocol is based on the amplification of the signal by the relay before being sent to the receiver. This has a negative effect on the quality of the signal received at the destination due to the inclusion of noise in the amplified signal. To achieve a BER of about 10^{-3} the required SNR for the MMSE-DF is about 3 dB less than the one for the MMSE-AF. That is quite a remarkable benefit. In contrast to this, in lower SNR AF, which requires less computing power and time, achieves comparable performance as of DF. Therefore, it is possible to recommend that using AF for lower SNR and DF for higher SNR has big advantage to have a network of less simple and inexpensive device.

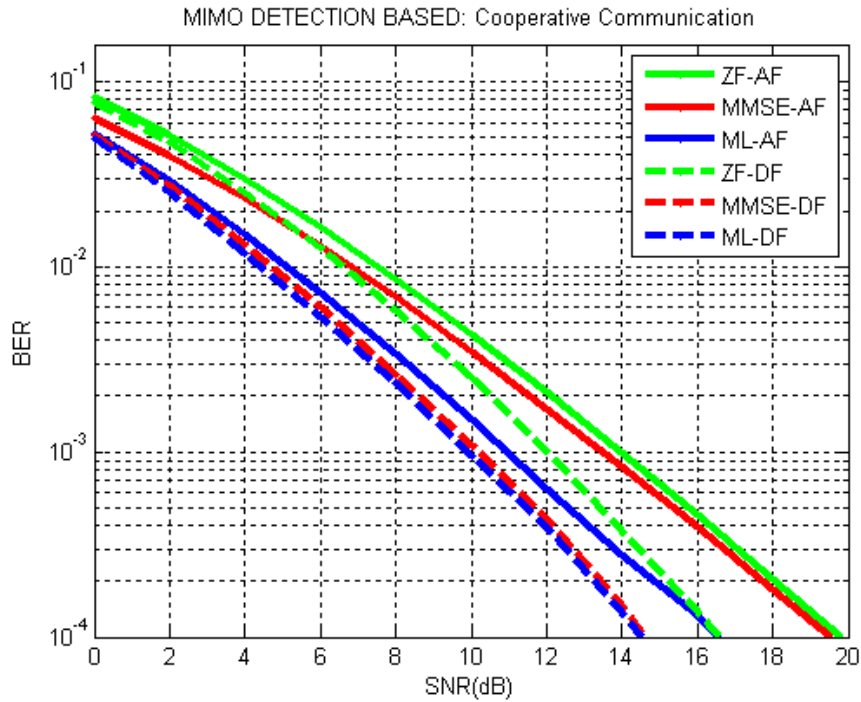

Figure 5.5: Comparative BER performance of amplify-and-forward and decode-and-forward under MIMO detection.

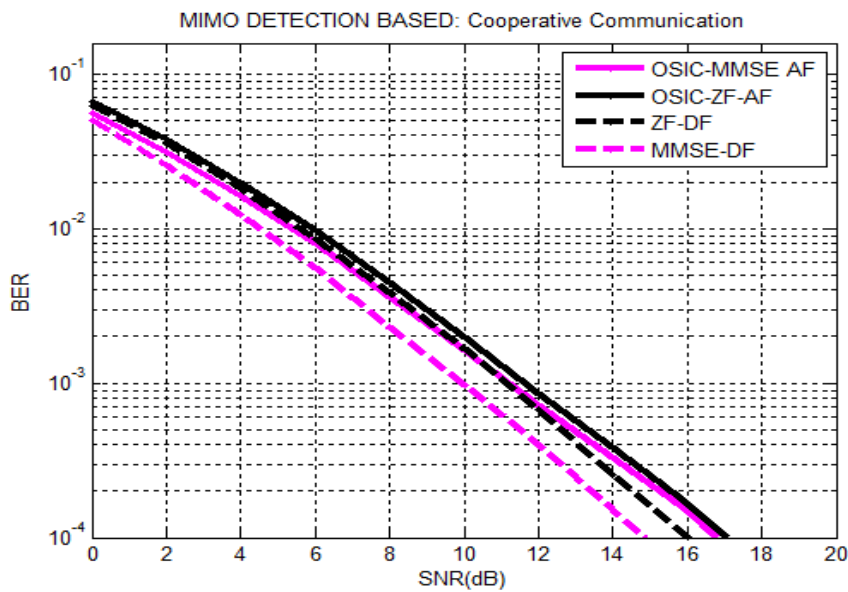

Figure 5.6: Comparative BER performance of amplify-and-forward and decode-and-forward under MIMO-OSIC detection.

5.1.2 Asymmetric Network Topology

For asymmetric network topology of Figure 5.7, it is assumed that S_1 is placed closer to the relay and destination than S_2 and therefore have less path loss and

better average SNR, i.e., the average channel gain of the direct and source relay link of S_1 is 4.6dB and 12dB better than that of S_2 respectively. With this asymmetric arrangement the different detection and relaying types are compared to see their advantages and disadvantages.

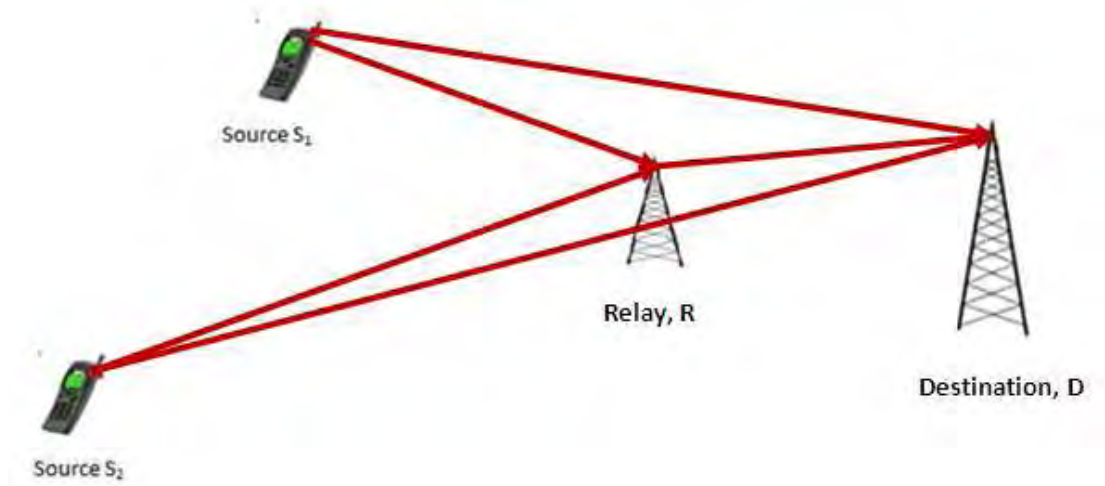

Figure 5.7: Asymmetric network topology.

5.1.2.1 Performance of Amplify-and-forward

Figure 5.8, shows the average BER of both user for asymmetric network topology under amplify-and-forward. We observe that, for user 1, MMSE has better performance than the ZF scheme at low SNR and has similar performance at high SNR. For user 2, both MMSE and ZF schemes maintain the same performance. Using the MMSE scheme only improves the performance of user 1 (having a better channel condition) compared to the ZF scheme at low SNR and has similar performance for high SNR while ML improves the performance of user 2 and maintains the performance of user 1 compared to both MMSE and ZF schemes.

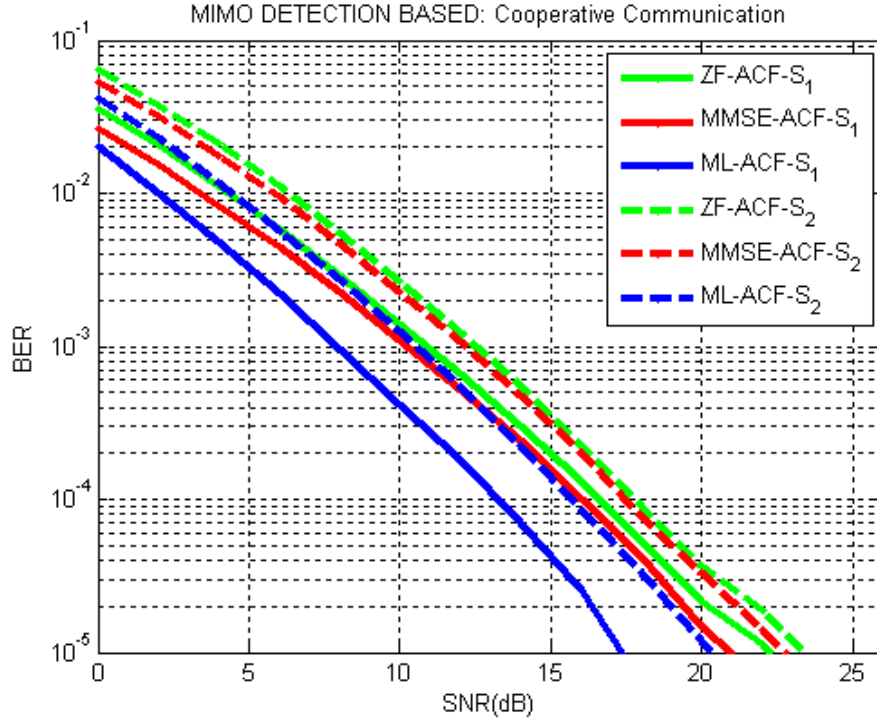

Figure 5.8: BER performance of amplify-and-forward under asymmetric distribution and MIMO detection.

Figure 5.9, shows the performance of each user under the considered asymmetric network topology for amplify-and-forward based on V-BLAST detection. Actually the big surprise is that the performance of the V-BLAST based on MMSE methods, which are computationally complex, is just about 1dB better than the one using V-BLAST based on ZF for user 1 and maintain the same performance for user 2. This is because as it has been discussed in the previous chapter, in AF relaying protocol the relay amplifies and superimposes the two user data in their noisy form. In doing so the noise is also amplified. But for this asymmetric arrangement the effect of the interference introduced by user 1 is small since it has less path loss and therefore the transformed noise will be small.

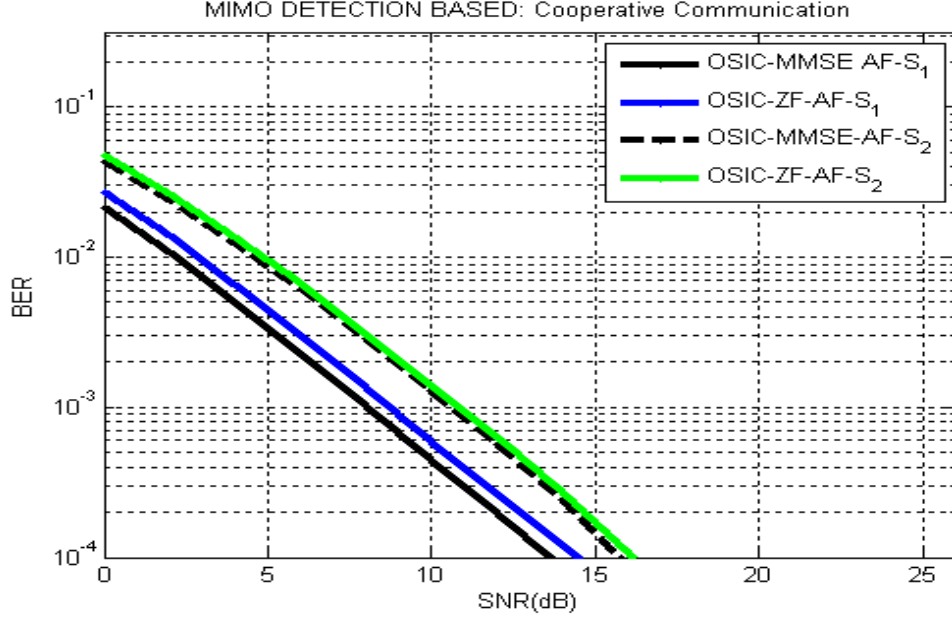

Figure 5.9: BER performance of amplify-and-forward under asymmetric distribution and MIMO-OSIC detection.

Figure 5.10, shows the BER averaged over both users for amplify-and-forward. It is clear to see that both V-BLAST based on MMSE and V-BLAST based on ZF achieve the performance of the ML detection, which has high computational complexity. The other important point worth observing from Figure 5.10 is the performance comparison of MIMO systems with network coding and conventional MARC systems. It clearly shows that the MIMO detection outperforms the other schemes. To achieve a BER of about 10^{-3} the required SNR for the non linear detection is about 3dB, 5dB and 11dB less than the one for the network coding, conventional MARC and point-to-point transmission respectively. Whereas linear MIMO detection achieve about 2dB better than network coding for lower SNR and same performance for higher SNR. That is quite a remarkable benefit.

The following table shows the BER performance of AF for user two using both symmetric and asymmetric network. It can be seen that the performance of AF under asymmetric is just about more than 1dB better than the one using symmetric. That is proposed model not only improve the performance of user having a better channel condition but also user with bad channel condition.

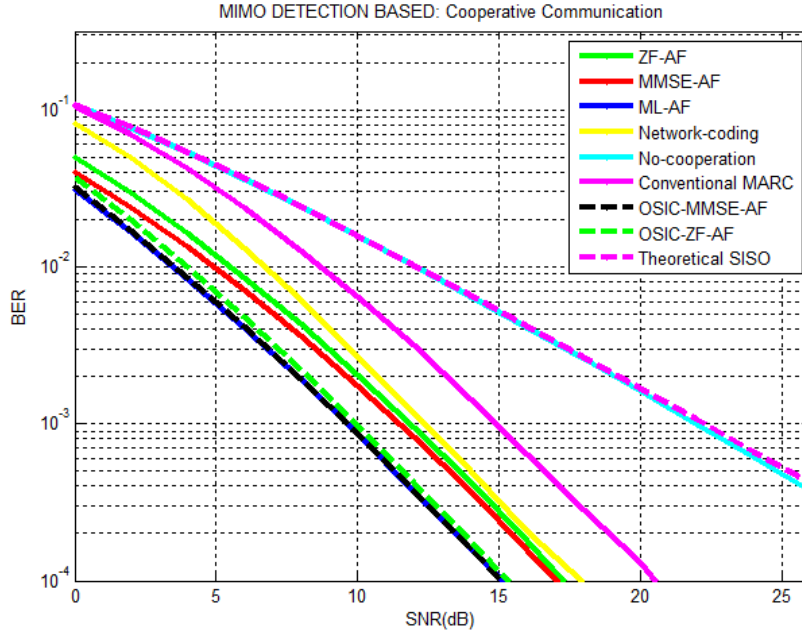

Figure 5.10: Average BER performance of amplify-and-forward under asymmetric distribution.

Table 5.2: BER for AF relaying using symmetric and asymmetric

Amplify-and-forward										
SNR(dB)	ZF		MMSE		ML		ZF-OSIC		MMSE-OSIC	
	Symm	Asymm	Symm	Asymm	Symm	Asymm	Symm	Asymm	Symm	Asymm
0	0.0816	0.0637	0.0637	0.0538	0.0524	0.0414	0.0653	0.0477	0.0558	0.0434
2	0.0513	0.0377	0.0397	0.0319	0.0293	0.0229	0.0376	0.0264	0.0316	0.0239
4	0.03	0.021	0.0232	0.0177	0.0151	0.0116	0.0198	0.0136	0.0164	0.0124
6	0.0165	0.011	0.0129	0.0094	0.0073	0.0058	0.0097	0.0067	0.0079	0.0061
8	0.0088	0.0055	0.0069	0.0047	0.0034	0.0028	0.0046	0.0031	0.0037	0.0028
10	0.0044	0.0027	0.0035	0.0023	0.0015	0.0012	0.0021	0.0014	0.0017	0.0013
12	0.0022	0.0012	0.0017	0.0011	0.0007	0.0005	0.0009	0.0006	0.0007	0.0006
14	0.001	0.0006	0.0008	0.0005	0.0003	0.0002	0.0004	0.0003	0.0003	0.0002
16	0.0005	0.0002	0.0004	0.0002	0.0001	0.0001	0.0002	0.0001	0.0001	0.0001

5.1.2.2 Performance of decode-and-forward

Figure 5.11, shows the performance of each user under asymmetric network topology for decode-and-forward. We observe that, to achieve a BER of about 10^{-3} the required SNR for the MMSE is about 4dB less than ZF for user one and 1dB less for user two. That is MMSE improves the performance of user one (having a better channel condition) compared to the ZF. Actually the big surprise is that the performance of the ML detection methods, which have high complexity, is

just about 1dB better than the one using MMSE for user one and shows the same performance for user two. Therefore should not be used at all.

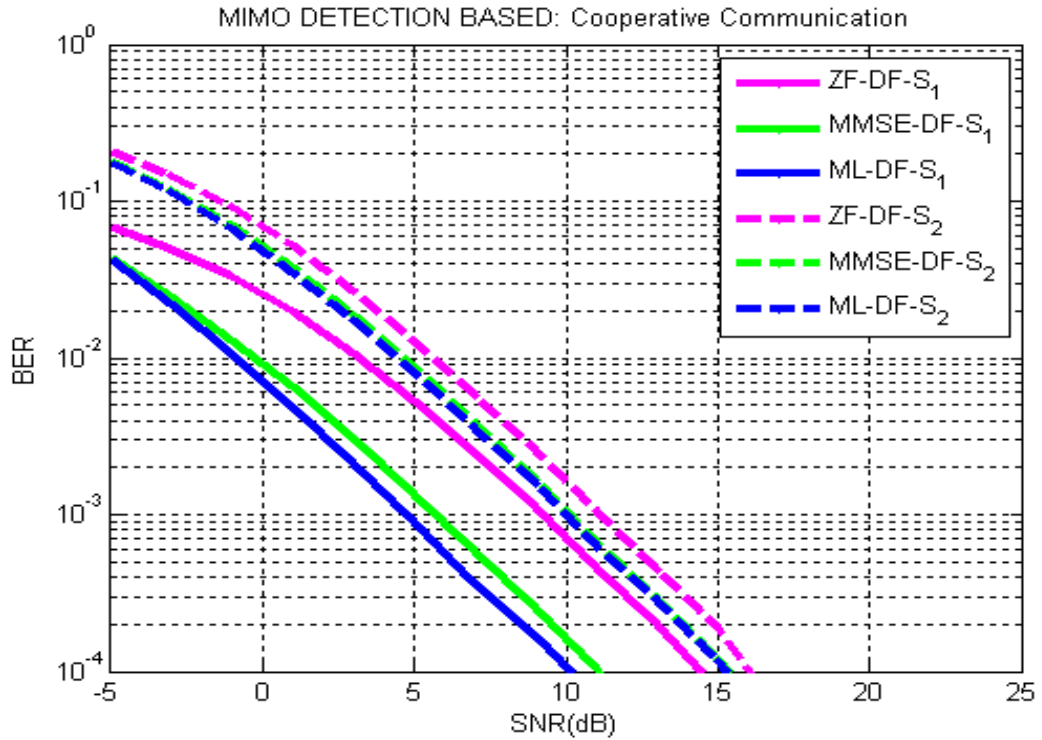

Figure 5.11: BER performance of decode-and-forward under asymmetric network and MIMO detection.

Figure 5.12 depicts the BER of each user for decode-and-forward based on V-BLAST detection. Inspection of the curves shows that, to achieve a BER of about 10^{-3} the required SNR for the MMSE is about 2.5 dB less than ZF for user one and shows the same performance for user two. Therefore, it is possible to say that MMSE improves the performance of user one (having a better channel condition) compared to the ZF. Therefore should not be used at all for user two.

Figure 5.13, shows the average BER performance for decode-and-forward. It clearly shows that the proposed detection schemes outperforms the other schemes over the simulated SNR range. The first thing that attracts attention is the performance of ML detection, which have high complexity, shows the same performance as of MMSE, OSIC-MMSE and is just about 1dB better than the one

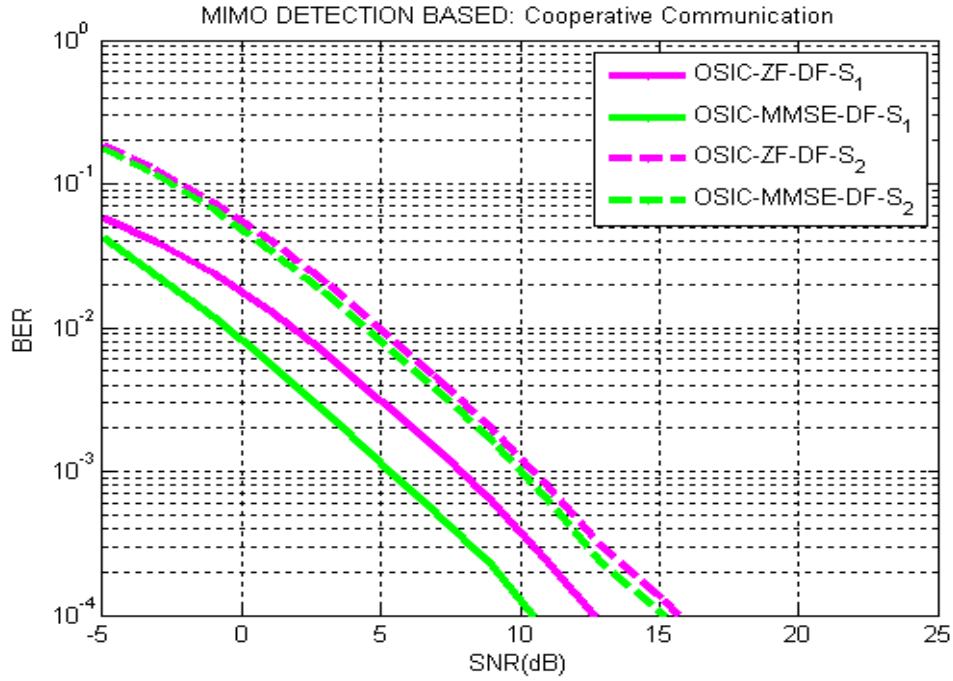

Figure 5.12: BER performance of decode-and-forward under asymmetric network MIMO-OSIC detection.

using OSIC-ZF. Therefore it possible recommends that for a network of asymmetric arrangement using MMSE detection has big advantage as it allows to attain the performance of ML detection.

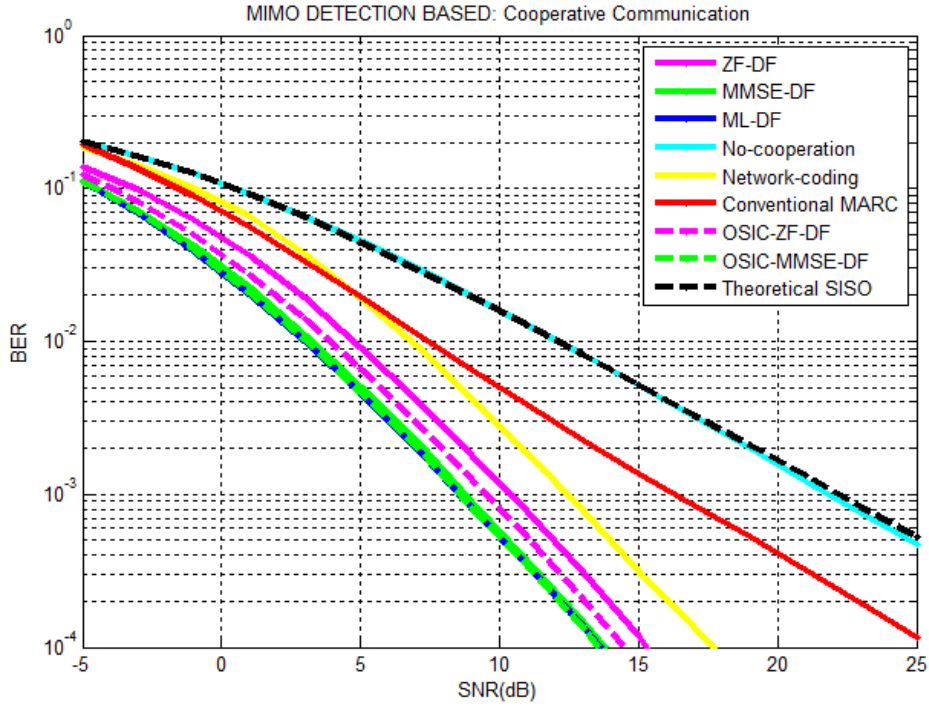

Figure 5.13: Average BER performance of decode-and-forward under asymmetric network distribution and MIMO detection.

5.1.3 Moving the relay

So far, the relay stations were positioned at fixed point; instead in practical scenario the relay is movable. In this section the effects of relay position is studied and finally recommend the best position. For the following simulations the DF diversity protocol is used and the incoming signals at the destination are combined using ML detection. As seen in the simulation above this is the detection that results in the best possible performance without regarding its complexity.

Figure 5.14 show the BER contour curve averaged over both users with respect to the region in which the relay placed; where the BER remain constant for a given relay region and the two sources and destination form the vertex of a triangle and Figure 5.15 is the three dimensional plots of the BER contours. Because of the variable relay location, the source-relay channels are asymmetric. For this simulation, the average SNR of the channel connecting all nodes is set to be 15dB. In general we can have the following basic observation.

- The closer the relay comes to the source, the further away is the destination and therefore the worse is the channel quality of the second hop. The quality of the first hop is more important for the overall channel quality than the second hop, so the performance is not symmetrical.
- The best performance is achieved, when the relay is situated in between the source and the destination, or slightly closer to the sending station. The resulting performance is not symmetrical at all. The preferred position of the relay is in the middle between the sender and the destination. When this is not possible the relay should be closer to the source than to the destination.

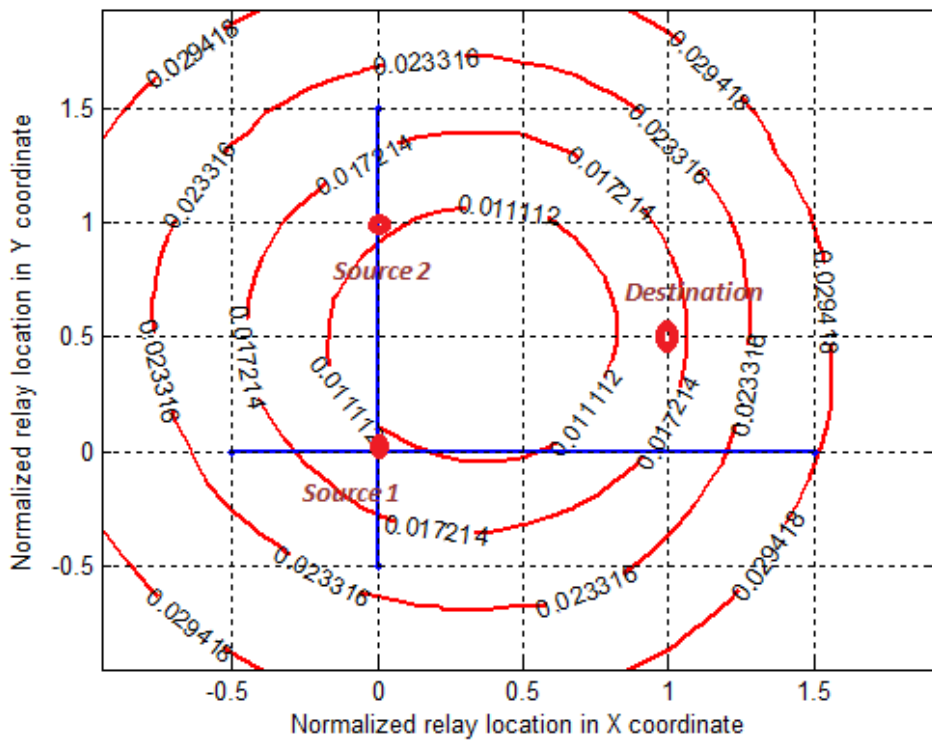

Figure 5.14: BER contours for decode-and-forward with ML detection.

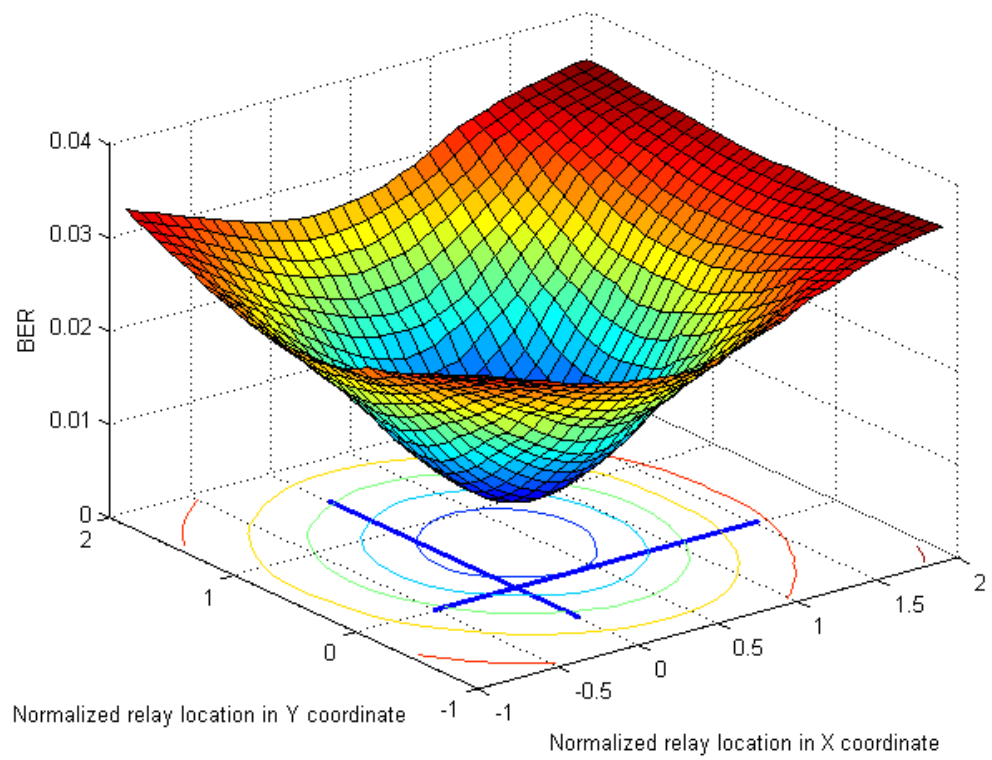

Figure 5.15: Three dimensional plot of the BER contours of decode-and-forward with ML detection.

Chapter 6

Conclusions and Recommendations for Future Work

6.1 Conclusions

This thesis has shown the potential benefits of a wireless transmission using cooperative diversity as it provides an attractive and practical solution for future high speed wireless communications system due to spatial diversity, which can effectively mitigate fading, and increases the network coverage by communicating over long distance or around an obstacle. The diversity is realized by building an ad-hoc network using relay. The data is sent directly from the source to the destination or via the relay station. Such a system has been simulated to see the performance of different diversity protocols and various detection methods.

In this thesis, we have created a model for designing and evaluating wireless network that take advantage of certain kinds of cooperation among terminals. Specifically, in these cooperative diversity techniques sets of terminals (two in our case) transmit to a common destination with the assistance of a single relay to create a virtual antenna array. In the classical relay channel model, there is a single source terminal with information to communicate, and additional relay

terminals, in which the relay represent additional resources, e.g., power, bandwidth, and computation, that can be freely utilized by the source terminal; thus, the scarce and expensive radio channel resource are not effectively used. A cooperative wireless network based on MIMO detection techniques designed and proposed. The common relay merges (using either AF or DF) the messages received from the sources, employing orthogonal superposition modulation, and forwards it to the destination; so that the relay resource is shared.

The DF protocol has shown a better performance than the AF protocol whatever detection method was used at the receiver. But it must be considered that an error correcting code was added to the transferred signal. To get the potential of the DF protocol the CRC was introduced to simulate an error correcting code.

The choice of detection method has a big effect on the error rate at the receiver. When AF is used at the relay station MMSE based on V-BLAST, which has manageable computational complexity, shows some benefits compared to the ML whose computational complexity grows exponentially with number of antennas and/or constellation points. When DF is used at the relay station MMSE which has manageable computational complexity, shows same performance to ML. Using ML has no performance gain as compared to MMSE and therefore should not be used at all.

The location of the relay is crucial to the performance. The best performance was achieved when the relay is at equal distance from the source and the destination or slightly closer to the source. In general the relay should not be too far from the region between the three stations.

6.2 Recommendations for Future Work

Here are list of recommendations to the possible extensions of the works of this thesis research:

- MIMO detection schemes developed in this thesis consider only a four node wireless network. Further works can extend these schemes for a system with more than two sources (i.e. extend it to larger networks) based on common relay and destination, which can improve the spectrum utilization efficiency.
- Realistic wireless channels are time varying which implies time varying system capacity. Therefore, it is desirable to study and incorporate adaptive resource allocation techniques, superposition weight factor, which defines the amount of power that is allocated to source and relay.
- Perfect channel state information at the relay and destination is assumed. However, obtaining CSI is another challenge under practical situations. Thus, it would be valuable to design simple and efficient channel estimation techniques.
- An orthogonal transmission strategy has been considered in this work which can impact the spectrum utilization efficiency; it would be beneficial to deal it with non orthogonal relay strategy.
- Although our proposed cooperation scheme is based on BPSK modulation, it can be easily extended to other forms of modulation, such as 16-QAM and 64-QAM, and beneficial to analyze its performance.
- Finally, one can think of improving the proposed transmission scheme by implementing ARQ-type feedback, thereby letting the relay transmit the superimposed message only when the destination was unable to decode the direct transmission.

Bibliography

- [1] Sendonaris, E. Erkip, and B. Aazhang, "*User cooperation diversity-Part I: system description*," IEEE Trans. Commun., vol. 51, Nov. 2003.
- [2] E. G. Larsson and B. R. Vojcic, "*Cooperative transmit diversity based on superposition modulation*," IEEE Commun. Lett., vol. 9, Sep. 2005.
- [3] Ioannis Krikidis, "*Analysis and optimization issues for superposition modulation in cooperative networks*", IEEE Transactions on Vehicular Technology, vol. 58, no. 9, November 2009.
- [4] V. Mahinthan, J. W. Mark, and X. Shen, "*A cooperative diversity scheme based on quadrature signaling*," IEEE Trans. Wireless Commun., vol. 6, No. 1, pp. 41-45, Jan. 2007.
- [5] Lei Xiao, Thomas E. Fuja, Jörg Kliewer, Daniel J. Costello, Jr. "*Cooperative diversity based on code superposition*", IEEE Transactions on Communications, vol. 57, no. 10, October 2009.
- [6] Ozgur Yilmaz, "*Cooperative multiple access in fading relay channel*", International Conference on Communications (ICC), Istanbul, Turkey, 2006
- [7] Tao Yang, "*Performance of iterative decoding for superposition modulation-based cooperative transmission*", IEEE Transactions on Wireless Communications, vol. 9, No. 1, January 2010.
- [8] Lin, R., Martin, P.A., Taylor, D.P., "*Two-user cooperative transmission using superposition modulation and soft information combining*", Ottawa, Canada: IEEE Vehicular Technology, Fall 2010, 6-9 Sep 2010.

- [9] Dereje H. Woldegebreal, Holger Karl, "*The performance of multiple-access relay channel with network coding and non-ideal source-relay*", 4^(th) International symposium on: wireless communication systems, ISWCS, 2007.
- [10] Junsong Wang, Ke Deng, Qinye Yin, "*Smart cooperation through orthogonal signaling and optimal power allocation*," IEEE ICC 2011.
- [11] Christoph Hausl and Philippe Dupraz, "*Joint network-channel coding for the multiple-access relay channel*", Institute for Communications Engineering (LNT), Munich University of Technology (TUM), 2006.
- [12] Xiaoyan Xu, Mark F. Flanagan, Norbert Goertz, "*A shared-relay cooperative diversity scheme based on joint channel and network coding in the multiple access channel*", IEEE Transaction on wireless Communications, VOL. 9, NO. 8, AUGUST 2010.
- [13] Yonghui, Branka Vucetic, Tan F. Wong, and Mischa Dohler, "*Distributed turbo coding with soft information relaying in multihop relay networks*", IEEE journal on selected areas in communications, Australia, 2006.
- [14] Quang Trung Duong, "*On Cooperative communications and its application to mobile multimedia*", Blekinge Institute of Technology, Sweden, 2010.
- [15] Manav R. Bhatnagar and Are Hjørungnes, "*Differential relay strategies over downlink channel in two-user cooperative communication system*", Manuscript revised for Wireless Personal Communications on December 25, 2008.
- [16] Tae-Won Yune, Dongsik Kim, and Gi-Hong Im, "*Iterative detection for spectral efficient user cooperative transmissions over multipath fading channels*", IEEE Transactions on communications, vol. 58, no. 4, April, 2010.
- [17] A. Mahmood, "*Cooperative diversity in wireless networks*", Journal of Engineering Science and Technology Review 3, 2010.

- [18] Sintayehu Dehnie and Huserv T. Sencar, Nasir Memon, " *Cooperative amplify and forward in the presence of a selfish partner*", 42nd Annual Conference on Information Sciences and Systems , 2007.
- [19] Nirmalendu bikas sinha, Bera. mitra, " *Capacity and V-BLAST techniques for mimo wireless channel*", Journal of Theoretical and Applied Information Technology, 2010.
- [20] Jun Wang, Oliver Yu Wen and Shaoqian Li, " *Soft-output MMSE MIMO detector under ML channel estimation and channel correlation*" IEEE signal processing letters, vol. 16, NO. 8, August 2009.
- [21] Namshik Kim, Yusung Lee, and Hyuncheol Park, " *Performance analysis of MIMO system with linear MMSE receiver*", IEEE transactions on wireless communications, vol. 7, no. 11, November 2008.
- [22] Qiang Li, " *On multiple-antenna communications: signal detection, error exponent and quality of service*", Texas A and M University, 2007.
- [23] Dominik Seethaler, Harold Artes, and Franz Hlawatsch, " *Detection techniques for MIMO spatial multiplexing systems*", Elektrotechnik und Informationstechnik, vol. 122, no. 3, March 2005, pp. 91–96, 2005.
- [24] LI Jing GE JianHua, Wang Yong, Tang YunShua and Xiong, " *A bandwidth efficient two-user cooperative diversity system with limited feedback*", science in china series F: information science, 2009.
- [25] A. Mahmood, " *Cooperative diversity in wireless networks*", journal of Engineering Science and Technology Review, July 2010.
- [26] Eckhard Ohlmer and Gerhard Fettweis, " *Linear and non-linear detection for MIMO-OFDM systems with linear precoding and spatial correlation*", Vodafone Chair Mobile Communications Systems, Technische Universität Dresden, Germany, 2010.
- [27] E. C. van der Meulen, "Three-terminal communication channels", *Advances in Applied Probability*, vol. 3, pp. 120–154, 1971.

- [28] T. M. Cover and A. A. El Gamal, "Capacity theorems for the relay channel," IEEE Trans. Inf. Theory, vol. 25, no. 5, pp. 572–584, Sep. 1979.
- [29] De-Li Jia, Gang Wu, Wei Lin, and Shao-Qian Li, "*Downlink cooperative transmission by superposition modulation: performance analysis and power allocation strategy*", *Journal of Communications*, VOL. 5, NO. 4, April 2010.
- [30] G. Kramer and A. J. van Wijngaarden. "On the white gaussian multiple-access relay channel", In Proc. IEEE International Symposium on Information Theory (ISIT), June 2000.
- [31] Xiangdong Jia, Haiyang Fu, Longxiang Yang and Laiqiang Zhao, "*Superposition coding cooperative relaying communications: Outage performance analysis*," *International Journal of Communication System*, 2011.
- [32] Li Huang, Zesong Fei, Jingming Kuan, "A decode-and-forward relaying scheme based on orthogonal superposition modulation," IEEE International Conference on Communication Technology, 2008.
- [33] Sudharman K. Jayaweera, "*Virtual MIMO-based cooperative communication for energy-constrained wireless sensor networks*," *IEEE Transaction on Wireless Communication* VOL. 5, NO. 5, May 2006.
- [34] Petar Popovski and Elisabeth de Carvalho "Spectrally-efficient wireless relaying based on superposition coding," Department of Electronic Systems, Aalborg University, Denmark, 2007.
- [35] Chirawat Kotchasarn, Kazi M. Ahmed, R. M. A. Premanandana-Rajatheva "*Bit error rate of two-user cooperative diversity in frequency selective rayleigh fading channel*," *Journal of Electrical Engineering*, VOL. 58, NO. 5, 2007, 279-284.
- [36] Ramesh Chembil Pala "Performance analysis of cooperative communication for wireless networks," Ph.D dissertation, Virginia Polytechnic Institute and State University, 2006.

- [37] A. van Zelst, R. van Nee and G. A. Awater, "*Space division multiplexing (SDM) for OFDM systems*", *51st IEEE Veh. Tech. Conf. (VTC) 2000-Spring Proceedings, Japan, vol.2, May 2000, pp. 1070-1074*.
- [38] Branka Vucetic, Jinhong Yuan "Space-Time Coding" John Wiley and Sons Ltd, 2003.