



ADDIS ABABA UNIVERSITY

ADDIS ABABA INSTITUTE OF TECHNOLOGY

SCHOOL OF ELECTRICAL AND COMPUTER ENGINEERING

MASTER'S THESIS FINAL REPORT

Studies on Power Quality Problems and Design of Mitigation Techniques:

Case Study- Africa PLC (Macaroni and Pasta Factory)

By

Getu Tadesse Geleta

A thesis submitted to the School of Electrical and Computer Engineering, Addis Ababa University in partial fulfillment of the Degree of Master of Science in Electrical Power Engineering

Advisor

Dr.-Ing. Getachew Biru Worku

Addis Ababa, Ethiopia

November, 2015



ADDIS ABABA UNIVERSITY

ADDIS ABABA INSTITUTE OF TECHNOLOGY

SCHOOL OF ELECTRICAL AND COMPUTER ENGINEERING

**Studies on Power Quality Problems and Design of Mitigation Techniques:
Case study - Africa PLC (Macaroni and Pasta factory)**

By **Getu Tadesse Geleta**

APPROVED BY BOARD OF EXAMINERS

Dr. Murad Ridwan
Chairman, Department of Graduate Committee

Signature

Dr.-Ing. Getachew Biru Worku
Advisor

Signature

Prof. N.P. Singh
Internal examiner

Signature

Dr. Solomon Kidane
External examiner

Signature

Declaration

I, the undersigned, declare that this thesis work is my original work, has not been presented for a degree in this or any other universities, and all sources of materials used for the thesis work have been fully acknowledged.

Name: Getu Tadesse

Signature: _____

Place: Addis Ababa, Ethiopia

Date of submission:

This thesis has been submitted for examination with my approval as a university advisor.

Dr.-Ing. Getachew Biru

Signature: _____

Advisor's name

Acknowledgement

I would like to forward my heartfelt thanks and appreciation to my Advisor Dr.-Ing. Getachew Biru whose advices, continuous support and guidance helped me throughout the preparation of this thesis work. Without his assistance, this thesis would not be possible.

I would also like to thank Ethiopian Energy Authority for providing me with the necessary devices in the assessment of the data.

Lastly, I want to thank the managers and technical directors of Africa PLC for their willingness to give the data and information needed for the thesis work.

Getu Tadesse Geleta

Table of Contents

	page
Declaration	i
Acknowledgement	ii
Table of Contents	iii
List of figures	vi
List of Tables	viii
List of Abbreviations	ix
Abstract	1
CHAPTER ONE Introduction	2
1.1. Background.....	2
1.2. Motivation and Statements of Problem	2
1.3. Objectives of the Thesis	3
1.3.1. The General Objective	3
1.3.2. The Specific Objectives	3
1.4. Methodology.....	3
1.5. Use of Software Tools	5
1.6. Cost benefit Analysis.....	6
1.7. Organization of the Thesis.....	6
CHAPTER TWO The Power Quality Phenomena	8
2.1. Introduction	8
2.2. Literatures review.....	8
2.3. Power quality problems classification.....	10
2.3.1. Voltage Transient	11
2.3.2. Voltage Variation	15
2.3.2.1. Short-Duration Voltage Variation.....	15
2.3.2.2. Long Duration Voltage Variation	17
2.3.3. Voltage Unbalance	20
2.3.4. Voltage Fluctuation	21

2.3.5. Waveform Distortion.....	22
2.3.6. Power Frequency Variation.....	29
CHAPTER THREE Data Collection, Analysis of Power Quality Problems and Proposed Mitigation Techniques	31
3.1. Introduction	31
3.2. Data Collection and Analysis	32
3.2.1. Sustained Interruption Data Analysis	32
3.2.2. Voltage variation data Analysis	34
3.2.3. Wave form distortion data Analysis	37
3.2.4. Summary of voltage variations	58
3.2.5. Summary voltage and current unbalances	59
3.2.6. Summary of power frequency variation	60
3.3. Sources of Power Quality Problems at Africa PLC	60
3.4. Proposed Mitigation Techniques	62
3.4.1. Harmonics mitigation systems.....	62
3.4.2. Power factor correction.....	64
CHAPTER FOUR Simulation Studies	68
4.1. Introduction	68
4.2. Under Voltage.....	68
4.3. Design of Power Factor Corrector.....	68
4.4. Harmonic Distortion Mitigation.....	69
4.4.1. Filter design and Power Factor upgrading for transformer 1.....	69
4.4.2. Filter design and power factor upgrading for transformer supplying pasta processing machineries	81
4.5. Modelling of the System Using Mat lab Simulink.....	91
4.6. Loss reduction in the distribution networks	96
4.7. Economic Analysis of Mitigation Techniques	100
4.8. Result Discussion	100
CHAPTER FIVE Conclusions, Recommendations and Future Work.....	102
5.1. Conclusions	102
5.2. Recommendations	103

5.3. Suggestions for Future work.....	103
References.....	104
Appendix A.....	106
Appendix B.....	107
Appendix C.....	108
Appendix D.....	109

List of figures

	Page
Figure 1.1: Methodology diagram	4
Figure 1.2: Power quality analyzer model - 8335.....	5
Figure 1.3: Mat lab Simulink software	6
Figure 3. 1: One line diagram of power distribution system of Africa PLC	32
Figure 3.2: Voltage variation from transformer supplying new Macaroni processing machineries	35
Figure 3.3: Voltage variations from transformer supplying old Macaroni processing machineries	36
Figure 3.4: Voltage variation from transformer supplying Pasta processing machineries	37
Figure 3.5: THD _v and THD _i from transformer 1 at full load	40
Figure 3.6: Current harmonic components measured from transformer 1.....	43
Figure 3.7: Simulation of distorted waveform of single phase voltage for transformer 1	44
Figure 3.8: Harmonic spectral components of single phase voltage for transformer 1	44
Figure 3.9: Simulation of single phase distorted current wave for transformer 1	45
Figure 3.10: Harmonic spectral components of single phase current for transformer 1.....	45
Figure 3.11: THD _v and THD _i from the transformer 2.....	47
Figure 3.12: Individual current harmonic distortions from transformer 2.....	48
Figure 3. 13: Waveform of distorted single phase voltage for transformer 2.....	50
Figure 3.14: Spectral harmonic components of single phase voltage for transformer 2	51
Figure 3.15: Waveform of single phase current for transformer 2	51
Figure 3.16: THD _v and THD _i from transformer 2.....	52
Figure 3.17: Individual current harmonic distortions from transformer 3.....	53
Figure 3.18: Distorted voltage wave for transformer 3.....	55
Figure 3.19: Voltage harmonic spectral components wave for transformer 3.....	56
Figure 3.206: Representation of nonlinear loads as a current source for analysis [8]	64
Figure 3.217: Active, reactive and apparent power diagram [19]	65
Figure 4. 1: Three phase model for simulation of the system.....	92
Figure 4.2: Simulation diagram of three phase current wave forms before filter is connected to transformer 1	93
Figure 4.3: Simulation diagrams of three phase current wave forms after filter is connected to transformer 1	93
Figure 4.4: Simulation diagram of three phase voltage wave forms before filter is connected to transformer 1	94
Figure 4.5: Simulation diagram of three phase voltage wave forms after filter is connected to transformer 1	94

Figure 4.6: Simulation diagram of three phase currents wave form before is connected to transformer 3..... 94

Figure 4.7: Simulation diagram of three phase currents wave form after filter is connected to transformer 3..... 95

Figure 4.8: Simulation diagram of three phase voltage wave form before filter is connected to transformer 3..... 95

Figure 4.9: Simulation diagram of voltage wave form after filter is connected to transformer 3. 95

List of Tables

Table 3.1: Reliability indices of 15 kV feeders at Adama Substation.	33
Table 3.2: Design target values of reliability indices on per-annum basis [17]	33
Table 3.3: Harmonic current limits for individual end users from IEEE standard 519-1992.....	38
Table 3.4: Harmonic voltage limits, IEEE standard 519-1992.....	39
Table 3.5: Voltage data from transformer supplying new Macaroni machinerics at full load	41
Table 3.6: The average RMS current, THD _I current unbalance taken from the transformer 1 at full load	42
Table 3.7: RMS value of individual harmonic currents and voltages from transformer 1	43
Table 3.8: Average real power and power factor data measured on transformer 1	46
Table 3.9: RMS current, THD _I and voltage unbalance from transformer 2	48
Table 3.10: RMS voltage, THD _v and voltage unbalance from transformer 2.....	49
Table 3.11: RMS value of individual harmonic currents and voltages from transformer 2	50
Table 3.12: Frequency, Real power and Power factor data measured from transformer 2	51
Table 3.13: RMS voltage, THD _v and voltage unbalance from transformer 3.....	53
Table 3.14: RMS current, THDI and voltage unbalance from transformer 2.....	54
Table 3.15: RMS value of individual harmonic currents and voltage from transformer 3.....	55
Table 3.16: Average Frequency, Real power, Apparent power and Power factor data measured from transformer 3	57
Table 3.17: Voltage variation from the transformers.....	58
Table 3.18: Summary voltage and current unbalances for the three transformers	59
Table 3.19: Power frequency variation measured from the transformers.....	60
Table 4.1: Comparison of capacitor performance to IEEE-18 recommended limits for 5 th harmonic filter on transformer 1.	76
Table 4.2: Comparison of capacitor performance to IEEE-18 recommended limits for 7 th harmonic filter on transformer 1.	80
Table 4.3: Comparison of capacitor performance to IEEE-18 recommended limits for 5 th harmonic filter on transformer 3.	86
Table 4.4: Comparison of capacitor performance to IEEE-18 recommended limits for 7 th harmonic filter on transformer 3.	90
Table 4.5: Summary current harmonic distortion before and after filters are connected	97

List of Abbreviations

AAU	-	Addis Ababa University
AAIT	-	Addis Ababa University Institute of Technology
ANSI	-	American National Standard Institute
ASD	-	Adjustable Speed Drive
A_v	-	Average
DC	-	Direct Current
DF	-	Distortion Factor
DPF	-	Displacement Power Factor
D-STATCOM	-	Distribution Static Compensator
DVR	-	Dynamic Voltage Restorer
ECE	-	Electrical and Computer Engineering
EEU	-	Ethiopian Electric Utility
GUI	-	Graphic User Interphase
IEC	-	International Electrotechnical Commission
IEEE	-	Institute of Electrical and Electronics Engineers
I_{sc}	-	Short Circuit Current
kHz	-	Kilo hertz
kVA	-	Kilo Volt Ampere
ms	-	millisecond
MVA	-	Mega Molt Ampere
NEMA	-	National Electrical Manufacturers Association
NPV	-	Net Present Value
No	-	Number
ns	-	nanosecond
PC	-	personal computer
PCC	-	Point of Common Coupling
PF	-	Power Factor
PFC	-	Power Factor Correction
PFS	-	Power Factor Surcharge
PLC	-	Private Limited Company
PU	-	Per Unit

RMS - Root Mean Square

TDD - Total Demand Distortion

THD_I - Current Total Harmonic Distortion

THD_V - Voltage Total Harmonic Distortion

TVSS - Transient Voltage Surge Suppressor

UPS - Uninterruptable power supply

Abstract

This thesis presents assessment of power quality problems of Africa PLC (Pasta and Macaroni) factory which is located in Adama town about 80km from the center of Addis Ababa towards east. The assessment investigates the major electrical phenomena that disturb the power quality of this particular factory. As such, almost the majority of power quality phenomena listed by the IEEE Standard 1159-1995 are assessed in this thesis.

The necessary data are collected from the factory through direct measurement using harmonic analyzer as well as from recorded data at Adama substation. The collected data are analyzed and the results are then compared with the IEEE standards to identify the type and level of the power quality problems. The analysis of the harmonic distortion has indicated that the worst individual harmonic distortion of 25 % 5th and 22.5 % 7th harmonic components have been existing in the power distribution system of the factory. Again, it has been observed that the factory has been working with poor power factor which is 0.78. Consequently, shunt harmonic filters that have an added feature of power factor correction are designed to reduce the amount of current harmonics and for upgrading power factor. With the designed shunt harmonic filters the dominant harmonic components (5th and 7th) are reduced to less than 4% and average power factor has been upgraded to 0.96. Further the cost analysis of the designed mitigation system showed economic feasibility of the solution as it would take only 2 years and 9 months to repay the total cost involved in the proposed mitigation techniques.

The modeled systems with and without shunt harmonic filter have been simulated using Mat Lab /Simulink software to verify the improvements achieved in terms of power quality. The result showed significant improvements. It is concluded that the problems like harmonic distortion, power factor and power interruptions are severe compared with the standard values whereas the rest of the power quality issue like power frequency variation, voltage fluctuation, voltage unbalance, and current unbalance are within the allowable range. Furthermore the reliability analysis, it has been seen that the factory has been facing frequent power interruption. Recommendations are forwarded to EEU concerning the issue of power interruption.

Key Words: Power quality, Harmonics distortion, Harmonic filters, Mat Lab/Simulink, power factor, power interruption, reliability.

CHAPTER ONE

Introduction

1.1. Background

Electricity customers are exposed to power quality disturbances and hence could suffer from significant financial losses due to these problems. Large penetration of sensitive devices such as motor control drives in industrial and commercial facilities has substantially increased their susceptibility to power quality disturbances.

Most of the industries in Ethiopia are not studied for how efficient they are using the electrical energy, the quality power reaching them and also the disturbances they face from the power system. Wave form distortion especially harmonics and reactive power consumption due to inductive loads are among problems posed on power system from industries while voltage variation, power frequency variation and the rest are disturbance posed on industries from power system. The drop of the voltage, especially at the residential loads is causing early failure of equipment, blackening of light bulbs, and decreased efficiency and performance of high power appliances. Damage of electronic devices and burning of light bulbs have also occurred due to over voltages. This study focuses on identifying and assesses the power quality problems of Africa plc.

Africa PLC is an important food processing factory found in Adama city, about 80 km east of Addis Ababa. The factory is providing the community with pasta, macaroni and other related products. It is among power intensive industries found in Adama city.

1.2. Motivation and Statements of Problem

There are a lot of indications that shows the electric power quality is very low in Ethiopia. The industrial, commercial and residential customers are facing redundant power interruption, harmonic distortion problems, operating under poor power factor, etc. As already explained Africa PLC is food processing factory found in Adama city. As per the information obtained from the employees in the factory, the factory is faced with serious power quality problem which

includes overheating of the motors, dimming and burning of the lamps, poor power factor extra. This thesis focuses on identifying and evaluating the causes and effects of the problem with the possible solution.

1.3. Objectives of the Thesis

1.3.1. The General Objective

The general objective of the thesis is to study the power quality problems of the Africa PLC. Based on the result of the study, mitigation systems are designed and modeled to improve the power quality problems to the limit of IEEE standard.

1.3.2. The Specific Objectives

The specific objectives of the thesis are:

- Identify power quality problems in Africa PLC
- Study the major causes of the problems
- Identify undesirable impacts of power quality problems
- Compare the level of disturbance with standards
- Design and model appropriate mitigation systems
- Simulate the mitigation systems and observe the impact of the proposed solutions
- Make cost benefit analysis of the designed system
- Draw conclusions and recommendations relevant for practical implementation.

1.4. Methodology

The general methodologies used in this thesis are as shown below.

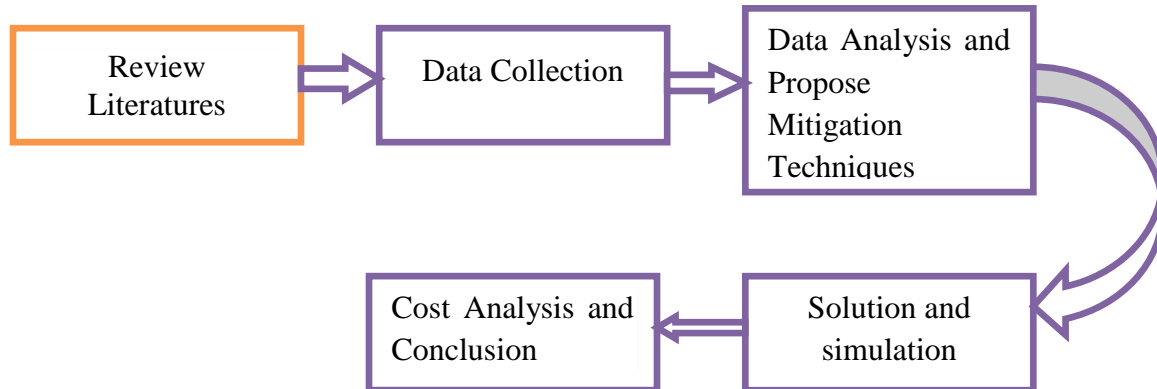

Figure 1.1: Methodology diagram

The work of different authors haven been reviewed under the topic called literature review and it has been considered one of the methodology used to do this Thesis.

The total task of data collection is accomplished through;

- Direct measurement: using power quality analyzer
- From recorded data and equipment specifications
- By interviewing people working in the factory and
- Through prepared questionnaires.

Power quality analyzer is utilized for measurement. The device can measure average three-phase RMS voltage and current, power, power factor, reactive and apparent power, frequency, active and reactive energy consumption, Individual and total harmonic distortion. Below is the figure which shows power quality analyzer used to get the data. Data collection also includes the study of documents, websites and other historical and documentary records relevant for the study.



Figure 1.2: Power quality analyzer model - 8335

Next to this, the data analysis method has been employed to identify the type and level of the problem found in the factory. When the level of the problem identified is beyond the limit of the IEEE standard; then the mitigations are designed and modeled.

1.5. Use of Software Tools

MATLAB/ Simulink is a software tool used in this thesis work for modelling and simulation purpose. Simulink is an input/output device GUI block diagram simulator. It contains a Library Editor of Tools from which we can build input/output devices; continuous and discrete time model simulations. Figure 1.3 below shows Sim Power Systems page of Simulink from which the modeling and simulation of the system is being done.

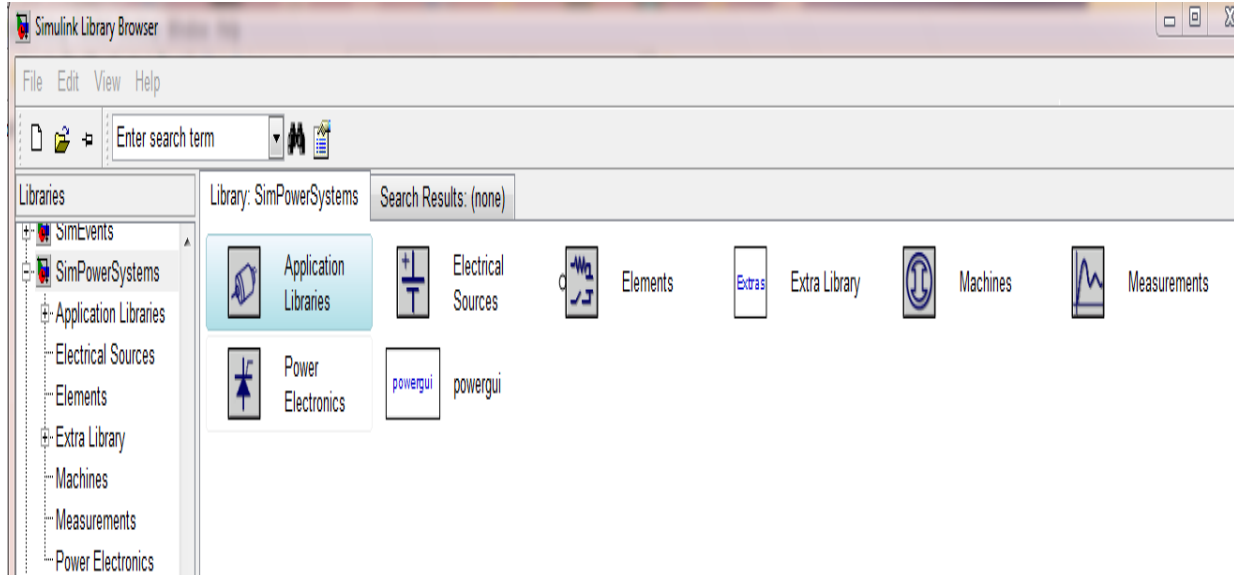

Figure 1.3: Mat lab Simulink software

1.6. Cost benefit Analysis

A number of financial analysis methods are available for studies to know the benefit versus cost of the solution option proposed for problems. The two most common techniques are Payback and Net Present Value [1]. Payback can be a quick method for comparing alternatives. Net Present Value (NPV) offers the advantage of accounting for the time-value of money. Simple payback period is employed for this study to calculate the time it will take for the factory to regain the money invested on the proposed power quality mitigation techniques.

$$\text{Simple payback period (in years)} = \frac{\text{Initial investment cost}}{\text{Annual operating saving}} \quad (1.1)$$

1.7. Organization of the Thesis

The thesis is organized into five chapters. This includes:

The first chapter discusses the introduction part in which the background, motivation, objective, literature review and methodology are discussed.

The power quality phenomena are described in the second chapter of this report. In this chapter, the power quality categories as per IEEE standard 1159-1995, causes and undesirable effects are discussed.

The third chapter includes data collection, analysis and proposed mitigation solutions. Under this chapter; collected data are analyzed, the problems are identified and respective solution are proposed.

Simulation results are put and discussed in the fourth chapter of this report. Proposed solutions are simulated using MATLAB /Simulink, the results are discussed and cost analysis has been presented.

The conclusions, recommendations and further research are addressed in the fifth chapter. The conclusions drawn from the research work, recommended solutions and areas of study suggested for further research are included in this chapter.

CHAPTER TWO

The Power Quality Phenomena

2.1. Introduction

Power quality problems encompass a large number of electrical and electromagnetic phenomena. Each phenomenon is caused by different situations. The first sign of a power quality problem is a deviation in the voltage waveform of the power source from sine wave in amplitude from an established reference level or a complete interruption. The disturbance can be caused by harmonics in the current or by events in the main voltage supply system. The disturbance can go for a fraction of a cycle (milliseconds) to great durations (seconds to hours) in the voltage supplied by a source.

The aim for method for correction is to make the power source meet an international standard. Power quality problem can basically start at four levels of the system that delivers electric power. The first one is the power plants and entire area transmission system. The second one is transmission lines and major substations. The third includes distribution substations. The last and fourth one includes service equipment and building wiring.

The study concentrates on power quality problems in Africa PLC: macaroni and pasta factory located in Adama city, about 80km east from center of Addis Ababa and the possible causes of these problems with possible solutions.

2.2. Literatures review

Power quality is certainly a major concern in the present era; it becomes especially important with the introduction of sophisticated devices whose performance is very sensitive to the quality of power supply. There are different power quality problems like voltage sag, voltage swell, voltage interruption, harmonic distortion and under voltage and over voltage. The increased awareness on power quality has resulted in the need to quantify the voltage performance of a distribution system. Different authors have contributed to study and mitigate power quality problems from various ideas. The reviewed literatures are presented as follows.

Before reviewing the work done on the area of power quality problems standard on different power quality phenomena have reviewed from different international organization's standards. These standards are important for the study of power quality phenomena. Some of the organizations are IEC, IEEE, ANSI and equipment manufacturer organization such as NEMA.

Shazly A. Mohammed, Abdel-Moamen M.A. and B. Hasanin [2] did analysis and modelling and simulation of Dynamic Voltage Restorer (DVR) for compensation of voltage quality disturbances. Accordingly, DVR provides the most commercial way to mitigate voltage sag by injecting voltage as well as power in to the system. Finally they found DVR handled both three phase balanced and unbalanced solutions without any difficulties. They injected appropriate voltage component to correct rapidly any disturbances in the supply voltage to keep the load voltage balanced and constant at the nominal value.

S.V Ravi Kumar and S.Siva Nagaraju [3] worked on simulation of D-STATCOM and DVR in power systems. They described the techniques of correcting supply voltage sag, swell and interruptions in a distributed system. In their work they used DVR to inject voltage in series with the system voltage and D-STATCOM to inject current into the system to correct the voltage sag, swell and interruption. Finally they found that DVR provide relatively better voltage regulation capabilities and also observed that the capacity for power compensation of DVR and D-STATCOM depends on the rating of storage devices.

Prakash sundaram¹, Shimi S.L.², Dr.S.Chatterji³ [4] published a paper entitled "Reduction in Harmonics in Marble Industry" on an industry found in India. After measuring the harmonic components of current, they found that the 5th harmonic content was beyond the IEEE limits, then design the harmonic filter. After installation of harmonic filter at Arihant Marble Industry, measurement were done again and found that 5th harmonic content was below IEEE limits. They are found shunt harmonic filters are economical way of mitigating harmonics.

Shady A. El-Kashlan and Hussein El-Desouki Saied [5] published a paper on power quality assessment via coordinated voltage control in distributed power generation. On their paper, they presented the advantages of active approach in distribution network operation. Their study focused on a voltage quality problem and introduced the coordinated voltage control technique to increase the share of distribution generation in distribution networks and to supply the customers with the required power quality.

M. Davudi, S. Torabzad, B. Ojaghi [6] has presented a paper on Analysis of Harmonics and Harmonic Mitigation Methods in Distribution Systems, using Electromagnetic Transient Analysis Program (ETAP).

2.3. Power quality problems classification

From the point of view of the electrical characteristics and duration of the power quality events that a conventional power system encounters the following power quality phenomena are considered in thesis, as categorized by IEEE standard 519-1995.

1. Voltage Transient

- Impulsive transient
- Oscillatory transient

2. Short duration voltage variation

- Interruption
- Sag
- Swell

3. Long duration voltage variation

- Under voltage
- Over voltage
- Sustained interruption

4. Waveform distortions

- DC offset
- Harmonics
- Inter harmonics
- Notching
- Noise

5. Voltage unbalance

6. Voltage fluctuations

7. Frequency deviations

2.3.1. Voltage Transient

The term transient describes voltage and/or current variation in a power system that is undesirable and momentary in nature. The main sources of transients are lightning strokes, capacitor switching, energizing transformers, power electronic converters and other switching phenomena within end-user systems [7] [8].

Transients caused by lightning strokes are often dangerous and result in a severe equipment damage unless proper protection systems are installed. However, capacitor switching usually results in non-dangerous transients. Switching of grounded-wye transformer banks may also result in unusual transient voltages in the local grounding system due to the current surge that accompanies the energization [8].

Adjustable-speed motor drives are adversely affected by the transient as they need a certain quality of power for the accurate adjustment of the motor drive. Insulation flashover, equipment overheating and damage are other undesirable effects of transient.

Surge arresters and transient voltage surge suppressors (TVSSs) are used to limit the transient over voltage. The elements that make up these devices can be classified by two different modes of operation, crowbar and clamping [7].

Crowbar devices are normally open devices that conduct current during overvoltage transients. Once the device conducts, the line voltage will drop to nearly zero due to the short circuit imposed across the line.

On the other hand, clamping devices for AC circuits are commonly nonlinear resistors (varistors) that conduct very low amounts of current until an overvoltage occurs. Then they start to conduct heavily, and their impedance drops rapidly with increasing voltage. Depending on their electrical natures, transients can be classified into two categories, impulsive and oscillatory [7].

I. Impulsive Transient

An impulsive transient is a sudden, unipolar and non-power frequency change in the steady-state condition of voltage and current. It is characterized by its amplitude, rise time and decay time, which can also be revealed by its spectral content. The spectral contents of impulsive transients are of mainly high frequency, due to its non-periodic nature of occurrence.

Because of the high frequency spectral contents, the shape of impulsive transients can be changed quickly by circuit components and may have significantly different characteristics when viewed from different parts of the power system. They are generally not conducted far from the source of where they enter the power system. Impulsive transients can excite the natural frequency of the power system circuits and produce oscillatory transients.

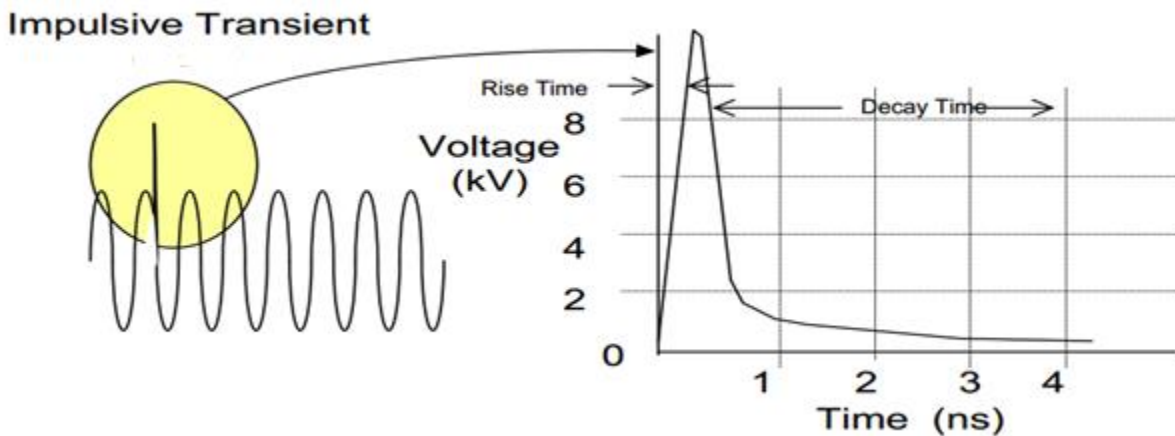

Figure 2.1: Typical positive impulsive voltage transient [9]

The most common cause of impulsive transients is lightning. An impulsive transient due to lightning strokes can occur because of a direct strike to a power line or from magnetic induction or capacitive coupling from strikes on adjacent lines [10].

The frequency and amplitude of lightning-induced transients vary geographically depending on the rainy nature of the area, vulnerability to lightning strokes and relative height of the system.

II. Oscillatory Transient

An oscillatory transient is a sudden, non-power frequency change in the steady state condition of voltage, current or both that includes both positive and negative polarity values. It is described by the frequency at which the oscillation takes place, the duration of the transient before it dies

out, and its magnitude. The commonly occurring oscillatory transients are categorized into subclasses of high frequency, medium frequency and low frequency oscillatory transients. The frequency ranges for these classifications are chosen to coincide with common types of power system oscillatory transient phenomena [9].

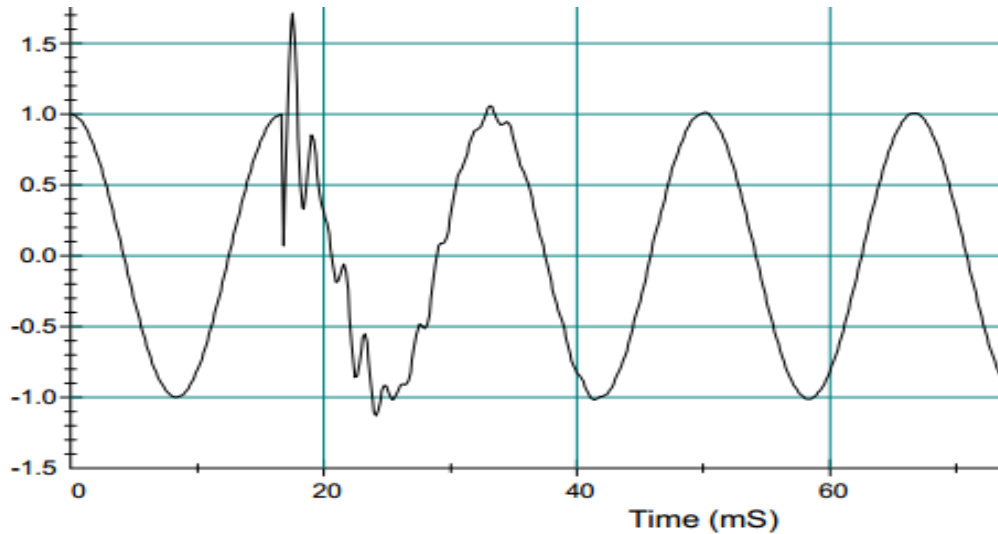

Figure 2.2: Oscillatory Transient [8]

a) High Frequency Transients

High frequency transients are oscillatory transients with a primary frequency component greater than 500 kHz and a typical duration measured in microseconds. These are often the result of a local system response to an impulsive transient. The transients can be in the high kilohertz range, last a few cycles of their fundamental frequency, and have repetition rates of several times per 50 Hz cycle (depending on the pulse number of the device) and magnitudes of 0.1 pu (less the 50 Hz component) [9].

b) Medium Frequency Transients

These are with a primary frequency component between 5 and 500 kHz with duration measured in tens of microseconds. Back-to-back capacitor energization results in oscillatory transient currents in the tens of kilo hertz. This phenomenon occurs when a capacitor bank is energized in close electrical proximity to a capacitor bank already in service. The energized bank sees the de-

energized bank as a low impedance path (limited only by the inductance of the bus to which the banks are connected, typically small) [7].

Cable switching results in oscillatory voltage transients in the same frequency range. Medium frequency transients can also be the result of a system response to an impulsive transient.

c) Low Frequency Transients

Low frequency transients are transients with a primary frequency component less than 5 kHz and duration of from 0.3 to 50 milliseconds. These are frequently encountered on utility sub transmission and distribution systems and are caused by many types of events. Capacitor bank energization results in an oscillatory voltage transient with a primary frequency between 300 and 900 Hz. The peak magnitude can reach 2.0 per unit, but is typically 1.3 to 1.5 per unit with duration of between 0.5 and 3 cycles depending on the system damping [7].

Oscillatory transients with principal frequencies less than 300 Hz can also be found on the distribution system. These are associated with transformer energization [7].

Due to the high frequency spectral contents of the oscillatory transients, they have undesirable effects of electromagnetic interference. High magnitude oscillatory transients can also damage electrical and electronic equipment due to the over voltage condition.

2.3.2. Voltage Variation

	transient	Swell		High voltage	
Event magnitude	110% Normal operating voltage				
	90%	transients	Voltage sag		Under voltage
			momentary	temporary	Sustained interruption
	10%		0.5 cycle	3sec	1minute
		Event duration			

Figure 2.3: Definition of voltage disturbance [source IEEE 1159:1195]

2.3.2.1. Short-Duration Voltage Variation

This category encompasses RMS-voltage variations that stay for a period of less than 1-minute. Short-duration voltage variations are caused by faulty conditions, energization of large loads, or intermittent loose connections in power wiring. The impact on the voltage during the actual fault condition is of the short-duration variation until protective devices operate to clear the fault.

Depending on the type of fault and the system conditions, the short duration voltage variation may be either a voltage sag (dip), voltage rise (swell), or interruption.

I. Voltage Sag

Voltage sag is a decrease in RMS-voltage or current to between 0.1 and 0.9 pu at the power frequency for durations of 0.5 cycle to 1 minute. Under voltages that last less than one half cycle cannot be characterized effectively by a change in the RMS value of the fundamental frequency value [9]. Therefore, these events are considered transients rather than sags. Voltage sags are

usually associated with system faults. They are also caused by energization of heavy loads, or starting of large motors that draw very large amount of current at startup [10].



Figure 2.4: Voltage sag [9]

II. Voltage Swell

It is defined as an increase in RMS voltage or current to between 1.1 and 1.8 pu at the power frequency for durations of 0.5 cycle to 1 minute.

As with sags, swells are usually associated with system fault conditions such as the temporary voltage rise on the un-faulted phases during a single line-to-ground fault. Swells can also be caused by switching off a large load or energizing a large capacitor bank. Incorrect positions of transformer tap-changers may also introduce a short duration over voltage condition at times of light system loadings.

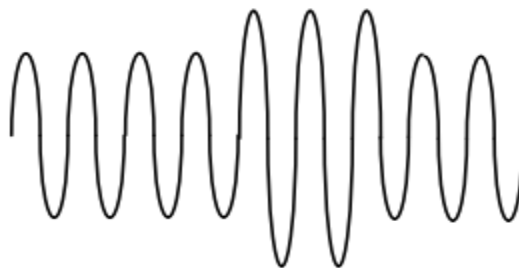

Figure 2.5: Voltage Swell [9]

III. Short Duration Interruption

A short duration interruption is said to occur when the supply voltage or load current decreases to less than 0.1 pu for a period of time not exceeding 1 minute. Interruptions result from power system faults, equipment failures, and control malfunctions. The duration of an interruption due to a fault on the utility system is determined by the operating time of utility protective devices. Instantaneous reclosing generally will limit the interruption caused by a nonpermanent fault to less than 30 cycles. Delayed reclosing of the protective device may cause a momentary or temporary interruption. The duration of an interruption due to equipment malfunctions or loose connections can be irregular.

2.3.2.2. Long Duration Voltage Variation

Long duration voltage variations encompass root-mean-square (RMS) deviations at power frequencies for longer than 1 minute. ANSI C84.1 specifies the steady state voltage tolerances expected on a power system [6]. A voltage variation is considered to be long duration when the ANSI limits are exceeded for greater than 1 minute.

The voltage variations, which may be either of short duration or long duration, are deviations of the voltage magnitude which last for more than half a cycle. Those deviations can be characterized using graphs of magnitude versus duration.

I. Under Voltage

An under voltage is a decrease in the RMS ac voltage to less than 90% at the power frequency for a duration of longer than 1 minute. It is the result of switching events and due to overloading.

Utilities generally try to maintain the service voltage supplied to an end user within ± 5 percent of nominal. Under emergency conditions, for short periods, ANSI Standard C84.1 permits the utilization voltage to be in the range of 6 to 13 percent of the nominal voltage. Some sensitive loads have more stringent voltage limits for proper operation and, of course, equipment generally operates more efficiently at near nominal voltage.

The root cause of most problems of under voltage is that there is too much impedance in the power system to properly supply the load [19]. Therefore, the terminal voltage drops too low under heavy load due to the weak power system (high voltage drop on the transmission

line). Conversely, when the source voltage is boosted to overcome the impedance, there can be an over voltage condition when the load drops too low.

Undesirable effects of under voltage are mainly:

- Malfunctioning of certain equipment
- Equipment operation at reduced efficiency
- Reduced performance at the lower voltage
- Equipment damage due to intensified undesirable effects.

II. Overvoltage

An over voltage is an increase in the RMS AC voltage greater than 110% at the power frequency for a duration longer than 1 minute. It is generally not a result of system faults, but is caused by load variations on the system and system switching operations, such as switching off a large load, energizing a capacitor bank, and incorrect tap settings on transformers. Over voltages result because either the system is too weak for the desired voltage regulation or voltage controls are inadequate. The position of the transformer tap-changer can also be a cause of over voltage during light load conditions.

The major undesirable effects of over voltage are burning of customer equipment, insulation flashover of utility equipment, exceeding breakdown voltage in capacitors and increased power loss due to higher shunt current between transmission lines of the three phases.

The range of solution lies in either of the utility transmission and/or distribution system or end-use customer system. Highly sensitive and expensive equipment of the end user may be provided with an over voltage protective device at the end use customer system.

However, it is both economical and inclusive to provide a reliable voltage regulation system at the utility transmission and/or distribution system. It is also the task of the utility to avoid over voltage conditions beyond some tolerable limits, so that the solution of that condition lies in the utility system.

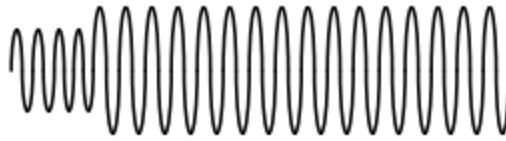

Figure 2.6: Over voltage [9]

III. Sustained Interruption

When the supply voltage drops to less than 10% of the nominal value for a period of time in excess of 1 minute, the long-duration variation is considered a sustained interruption. Interruptions can result from control malfunction, faults, or improper breaker tripping. Interruptions have their own impacts in the economic and social activities of a society and the country at large. Different industries and factories, public institutions and the likes are forced to stop their jobs due to electric power interruptions. The country's attractions for foreign investors are also affected by the electric power reliability and the consequent cost for power usage.

Interruption, which may be either of short duration or sustained, is characterized and quantified by the major reliability indices that are computed as follows:

Let C_i - Number of customer interruption

r_d - Duration of interruption

C_T - Total number of customer interruption for a given time

r_i - Number of interruption within given time

SAIFI: System average interruption frequency index indicates how often the average customer experiences a sustained interruption over a predefined period of time [8]. It is the ratio of total customer interruptions to total number of customer served.

$$SAIFI = \frac{\sum_i C_i * r_i}{C_T} \quad (2.1)$$

SAIDI: System average interruption duration index shows the total duration of interruption for the average customer during a predefined period of time [8]. It is commonly measured in customer minutes or customer hours of interruption.

$$SAIDI = \frac{\sum_i C_i * r_{id}}{C_T} \quad (2.2)$$

CAIDI: Customer average interruption duration index represents the average time required to restore service [11].

$$CAIDI = \frac{\sum_i C_i * r_i}{\sum_i C_i} \quad (2.3)$$

ASAI: Average system availability index represents the fraction of time (often in percentage) that a customer has received power during the defined reporting period [8].

$$ASAI = \frac{H_{ca}}{H_{cd}} * 100\% \quad (2.4)$$

Whereas:

H_{ca} - Customer hour's service availability, and

H_{cd} - Customer hour's service demand.

2.3.3. Voltage Unbalance

Voltage unbalance, also called voltage imbalance is non-equalization of the three phase voltages. It is defined by the National Electrical Manufacturers Association (NEMA) as 100 times the absolute value of the maximum deviation of the line voltage from the average voltage on a three-phase system, divided by the average voltage [9].

$$\text{voltage unbalance}(\%) = \frac{V_{\max} - V_{av}}{V_{av}} * 100 \quad (2.5)$$

Whereas:

V_{av} - Average three phase voltages

V_{\max} - Voltage magnitude of extreme phase

Unbalance is more rigorously defined in some standards using symmetrical components as the ratio of either the negative or zero sequence components to the positive-sequence component. The most recent standards specify that the negative-sequence method be used. It is recommended that the voltage unbalances at the motor terminals not exceed 1%.

Common causes of voltage unbalance include:

- Unevenly distributed single-phase loads on the same power system
- Unidentified single-phase to ground faults
- An open circuit on the distribution system primary
- Unbalanced or unstable utility supply
- Faulty operation of power factor correction equipment
- Unbalanced transformer bank supplying a three-phase load that is too large for the bank.

Voltage unbalance degrades the performance and shortens the life of a three-phase motor [9]. Voltage unbalance at the motor stator terminals causes phase current unbalance far out of proportion to the voltage unbalance. Unbalanced currents lead to torque pulsations, increased vibrations and mechanical stresses, increased losses, and motor overheating, which results in a shorter winding insulation life.

Unbalanced voltage inputs decrease the efficiency of a motor that it results in wastage of energy and in turn money. A motor will run hotter when operating on a power supply with voltage unbalance. The additional temperature rise is calculated with the following equation [9]:

$$\text{Percent additional temperature rise} = 2 * (\% \text{voltage unbalance})^2 \quad (2.6)$$

Winding insulation life is reduced by one-half for each 10°C increase in operating temperature.

2.3.4. Voltage Fluctuation

Voltage fluctuations are periodic variations of the voltage envelope or a series of random voltage changes that generally not exceed 10 percent of the nominal value.

Higher power loads that draw current which bears continuous and rapid variations in its magnitude can cause voltage fluctuations. The term flicker is derived from the impact of the voltage fluctuation on lamps such that they are perceived by the human eye to flicker. Although voltage fluctuation and flicker are often used interchangeably, strictly speaking, voltage fluctuation is an electromagnetic phenomenon while flicker is an undesirable result of the voltage on the humans' sense of seeing. One of the most common causes of voltage fluctuations on utility transmission and distribution systems is an arc furnace. On the other hand, during Ferro resonance the voltage magnitude may fluctuate wildly. End users at the secondary circuit

may actually see their light bulbs flicker. Some electronic appliances may be very susceptible to such voltage excursions. Prolonged exposure can shorten the expected life of the equipment or may cause immediate failure.

Voltage flicker is measured with respect to the sensitivity of the human eye. Typically, magnitude as low as 0.5 percent can result in lamp flicker if the frequency is in the range of 6 to 8 Hz [8]. The simplest and generally most effective technique for compensating for existing or potential flicker is to provide a sufficiently stiff source of power so that the effect is negligible at the point where the flicker source is tapped off from the rest of the power distribution system. Compensatory methods are also used to emulate the stiff source. Series capacitors, thyristor switching of inductors with shunt capacitors (static var control), saturating shunt inductors, and thyristor switched shunt capacitors may be used to maintain a relatively steady voltage at the tie point [8] [11].

A common solution to flicker-causing loads is to apply devices that are commonly called static VAR compensators. These can react within a few cycles to maintain a nearly constant voltage by rapidly controlling the reactive power production. Such devices are commonly used on arc furnaces, stone crushers, and other randomly varying loads where the system is weak and the resulting voltage fluctuations are affecting nearby customers.



Figure 2.7: Voltage fluctuation [9]

2.3.5. Waveform Distortion

Waveform distortion is defined as any steady-state deviation of the voltage and/or current waveform from an ideal sine wave of the power frequency. The waveform distortion is principally characterized by its spectral contents which are investigated using a Fourier transform, expressed as [1].

$$F(t) = F_0 + \sum_{h=2,4,6\dots}^{\infty} (F_h \cos(h * \omega_0 t + \phi_h)) + \sum_{h=1,3,5\dots}^{\infty} (F_h \sin(h * \omega_0 * t + \phi_h)) \quad (2.7)$$

Whereas:

- F(t) - Voltage/Current waveform
- F_O - Dc-component
- F_h - spectral content
- h - Harmonic number
- ω_o - Fundamental angular frequency and
- ϕ_h - Phase shift of the spectral content.

The effect of the harmonic contents on the distortion of the sinusoidal waveform can be observed from the above equation, equation (2.5).

Usually, the voltage waveform has negligible harmonics that it can be assumed to be pure sinusoidal at the fundamental frequency. In that case, if the current drawn by the load has harmonics, the active power of the load is consumed only at the fundamental component of the load current. The remaining harmonics generate a reactive power.

There are five primary forms of waveform distortion of which one or more events occur in a distorted voltage or current waveform.

I. DC Offset

DC offset is the dc voltage or current component of the spectral contents in an AC voltage or current. This occurs mainly as the result of a geomagnetic disturbance or asymmetry of electronic power converters, such as half-wave rectification. Mathematically, DC offset of a voltage or current waveform F(t) is expressed as follows [13]:

$$\text{DC offset} = \frac{1}{T} \int_0^T F(t) dt \quad (2.8)$$

Whereas:

- T - Period of the voltage/current waveform and
- F(t) - Voltage/Current waveform as a function of time, t.

Direct current in ac networks can have a detrimental effect by biasing transformer cores so they saturate in normal operation. This causes additional heating and loss of transformer life.

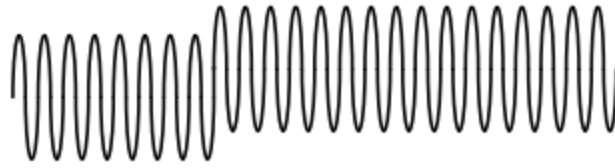

Figure 2.8: DC-offset wave forms [10]

II. Harmonics

Harmonics are sinusoidal voltage or current components of the waveform. They have frequencies that are integer multiples of the fundamental frequency. They are mathematically given as follows [14]:

$$H_h = \frac{1}{T} \int_0^T \{F(t) \cos(h\omega_0 t + \varphi_h)\} \quad (2.9)$$

Whereas:

H_h - h^{th} harmonic

T - Period of the voltage/current waveform

$F(t)$ - Voltage/Current waveform as a function of time t

h - Harmonic number

ω_0 - Fundamental angular frequency

φ_h - Phase angle of the h^{th} harmonic

The wave form containing harmonic spectral (odd) components can be expressed as follows [13] equation (2.8).

$$f(t) = \sum_{h=1}^{h_{\text{max}}} A_h \sin(2\pi h f_0 t + \varphi_h) \quad (2.10)$$

Whereas:

A_h - Maximum value of magnitude of harmonic spectra

f_0 - Fundamental frequency

Harmonics originate from the nonlinear characteristics of devices and loads that require currents other than a sinusoid on the power system. The most common of these loads are static power converters, although several other loads are also non-sinusoidal, such as the following [7]:

- Arc furnaces and other arc-discharge devices, such as fluorescent lamps

- Resistance welders (impedance of the joint between dissimilar metals is different for the flow of positive vs. negative current)
- Magnetic cores, such as transformer and rotating machines that require third harmonic current to excite the iron
- Synchronous machines (winding pitch produces fifth and seventh harmonics)
- Adjustable speed drives used in fans, blowers, pumps, and process drives
- Solid-state switches that modulate the current-to-control heating, light intensity, etc.
- Switched-mode power supplies, used in instrumentation, PCs, televisions, etc.
- Static var compensators
- Electronic phase controllers
- High-voltage DC transmission stations (rectifiers of AC to DC, and DC to AC invertors)
- Photovoltaic invertors converting DC to AC

Harmonic distortion levels are described by the complete harmonic spectrum with magnitudes and phase angles of each individual harmonic component. It is also common to use a single quantity, the total harmonic distortion (THD), as a measure of the effective value of harmonic distortion. Mathematically, THD values of voltage and current, THD_V and THD_I respectively, are given as follows [8].

$$THD_V = \frac{\sqrt{\sum_{h=2}^h V_h^2}}{V_1} \quad (2.11)$$

$$THD_I = \frac{\sqrt{\sum_{h=2}^h I_h^2}}{I_1} \quad (2.12)$$

Whereas:

- I_h - RMS of harmonic current components
- I_1 - RMS current at the fundamental frequency
- $V(h)$ - RMS of harmonic spectral components and
- V_1 - RMS voltage at the fundamental frequency

Total Demand Distortion (TDD) is another commonly used harmonic index used to quantify current distortion. It is similar to the THD concept except that the distortion is expressed as a

percentage of some rated or maximum load current magnitude, rather than as a percentage of the fundamental current. It is expressed as follows [7].

$$TDD_I = \frac{\sqrt{\sum_{h=2}^h I_h^2}}{I_L} \quad (2.13)$$

$$THD_V = \frac{\sqrt{\sum_{h=2}^h V_h^2}}{V_L} \quad (2.14)$$

Whereas:

I_L - rated load-current.

V_L - RMS voltage at load terminal

Individual demand distortion can be expressed as follows:

$$IDD_h = \frac{I_h}{I_L} \quad (2.15)$$

$$VDD_h = \frac{V_h}{V_L} \quad (2.16)$$

The degree to which harmonics can be tolerated is determined by the susceptibility of the load or utility equipment to harmonics. The least susceptible type of equipment is that in which the main function is in heating, as in an oven or furnace [8]. In this case, the harmonic energy generally is utilized and hence is quite completely tolerable. The most susceptible type of equipment is that whose design or constitution assumes a perfect (nearly) sinusoidal fundamental input. This equipment is frequently in the categories of communication or data processing equipment. A type of load that normally falls between these two extremes of susceptibility is the motor load.

A major effect of harmonic voltages and currents in rotating machinery (induction and synchronous) is increased heating due to iron and copper losses at the harmonic frequencies [8]. The harmonic components thus affect the machine efficiency, and can also affect the torque developed.

Harmonic currents in a motor can give rise to a higher audible noise emission. On the other hand, the harmonics can result in mechanical oscillations in a turbine-generator combination or in a motor-load system; produce a resultant flux distribution in the air gap, which can cause or enhance phenomena called cogging (refusal to start smoothly) or crawling (very high slip) in induction motors [8].

On transformers, current harmonics cause an increase in copper losses and stray flux losses, and voltage harmonics cause an increase in iron losses. The overall effect is an increase in the transformer heating. The transformer losses caused by both harmonic voltages and harmonic currents are frequency dependent. The losses increase with increasing frequency and, therefore, higher frequency harmonic components can be more significant than lower frequency components in causing transformer heating. Current harmonics also result in increased audible noise of the transformer.

Harmonics have a degrading effect on the performance of power transmission cables, capacitors, electronic equipment communication system, utility metering, and switch gear and relaying.

On the load itself, harmonics have the undesirable impact of decreasing the power factor as power factor is composed of two components [15] [11]. The first component is due to the phase shift between the sinusoidal input voltage and current at the power frequency induced by the inductive or capacitive nature of the load and is referred to as the Displacements Power actor (DPF).

$$\text{Displacement power factor} = \cos(\varphi) \quad (2.17)$$

The second component is due to non-linear characteristics of the load and is referred to as the distortion factor.

$$\text{Distortion Factor} = \frac{1}{\sqrt{1 + THD^2}} \quad (2.18)$$

The load's power factor is therefore the product of its distortion factor and its displacement power factor given as follows:

$$PF = \frac{1}{\sqrt{1 + THD^2}} \cos(\varphi) \quad (2.19)$$

Whereas:

P.F - Load's power factor

φ - The displacement angle between the fundamental current and voltage

THD - Total current distortion of load current.

Increased neutral current in 3-phase wye connected distribution networks is another undesirable effect of harmonics. In a 3-phase wye connected system, the neutral current is dominated by any dc-component and odd tripled harmonics which is expressed as (2.18):

$$I_{h(rms)} = \sqrt{I_0 + \sum_{k=3,9,12,\dots} (I_k^2)} \quad (2.20)$$

Whereas:

- $I_{h(rms)}$ - RMS current of the neutral wire
- I_0 - Dc-component of the phase current
- I_k - Tripled harmonic

III. Inter harmonics

These are voltage and/or current components having frequency that are not integer multiples of the fundamental frequency. They can appear as discrete frequencies or as a wideband spectrum. Interharmonics are generally the result of frequency conversion activities. The main sources of interharmonics are static frequency converters, cyclic- converters, induction furnaces, and arcing devices. Power line carrier signals can also be considered as interharmonics.

Inter harmonic currents can excite resonances on the power system as the varying interharmonic frequency becomes coincident with natural frequencies of the system. The higher frequency inters harmonic signals affect the power-line-carrier signaling. They can also induce visual flicker in fluorescent lamps and other arc lighting as well as in computer display devices.

IV. Notching

Notching is a drop in voltage as close to zero as permitted by system impedance caused by a momentary short circuit between two phases, during current commutation in the normal operation of power electronic devices.

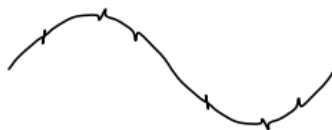

Figure 2.9: Notch wave forms [9].

Notching can ordinarily be characterized by its notch-depth and total notch area. Since notching occurs periodically, it can also be characterized through the harmonic spectrum of the affected voltage. However, the frequency components associated with notching are generally quite high and may not be readily characterized with measurement equipment normally used for harmonic analysis.

V. Noise

Noise is defined as unwanted electrical signals with broadband spectral content lower than 200 kHz superimposed upon the power system voltage or current in phase conductors, or found on neutral conductors or signal lines. Noise in power systems can be caused by power electronic devices, control circuits, arcing equipment, loads with solid-state rectifiers, and switching power supplies. Noise problems are often exacerbated by improper grounding that fails to conduct noise away from the power system. Basically, noise consists of any unwanted distortion of the power signal that cannot be classified as harmonic distortion or transients.

Noise disturbs electronic devices such as microcomputer and programmable controllers. The problem can be mitigated by using filters, isolation transformers, and line conditioners.

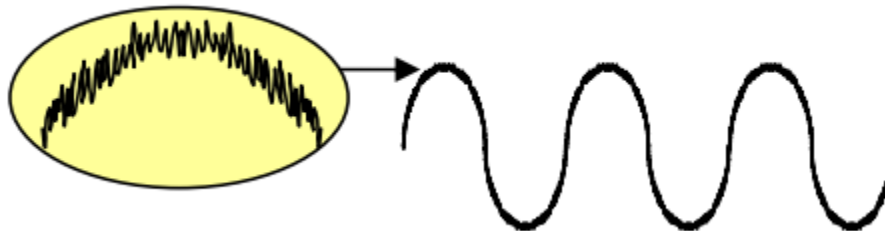

Figure 2.10: Noise waveform [9]

2.3.6. Power Frequency Variation

Power frequency variations are deviations of the power system fundamental frequency from its specified nominal value. The power frequency of a power system is directly related to the rotational speed of the generators supplying the system. Frequency variations occur as the dynamic balance between load and generation changes. The size of the frequency deviation and

its duration depend on the load characteristics and the response of the generation control system to load changes.

Frequency variations that go outside of accepted limits for normal steady-state operation of the power system can be caused by faults on the bulk power transmission system, a large block of load being disconnected, or a large source of generation going off-line. On modern interconnected power systems, significant frequency variations are rare.

Frequency variations of consequence are much more likely to occur for loads that are supplied by a generator isolated from the utility system. In such cases, governor response to abrupt load changes may not be adequate to regulate within the narrow bandwidth required by frequency-sensitive equipment. Frequency variations may cause a motor to run faster or slower to match the frequency of the input power [16]

As a solution to the problem of a constantly changing power frequency, each generating unit of the country should utilize effective governor control mechanisms to maintain the power frequency within the permissible range.



Figure 2.7: Power frequency variations [9]

CHAPTER THREE

Data Collection, Analysis of Power Quality Problems and Proposed Mitigation Techniques

3.1. Introduction

In chapter two, Literatures and background of different power quality problems have been discussed. The major causes of problems and options to reduce them are highlighted with reference to different Authors. Under this chapter, data have been collected and analyzed. After analysis of the data, mitigation solutions have been proposed.

The collected data have been analyzed and the levels of the disturbances have been compared to international standards. The schematic diagram of Africa PLC (Macaroni and Pasta) is shown in figure 3.1. It has three transformers each for different section of loads.

Data have been collected from the secondary winding of transformers with respective ratings of 1250KVA, 15/0.38KV, and 6% impedance.

The factory has three sections:

- ✓ New Macaroni section with an electrical load of capacity 102.709kVA and power factor of 0.814.
- ✓ Old Macaroni section with an electrical load of capacity 57.673 kVA and power factor of 0.768.
- ✓ Pasta section with an electrical load of capacity 59.857kVA and power factor of 0.764.

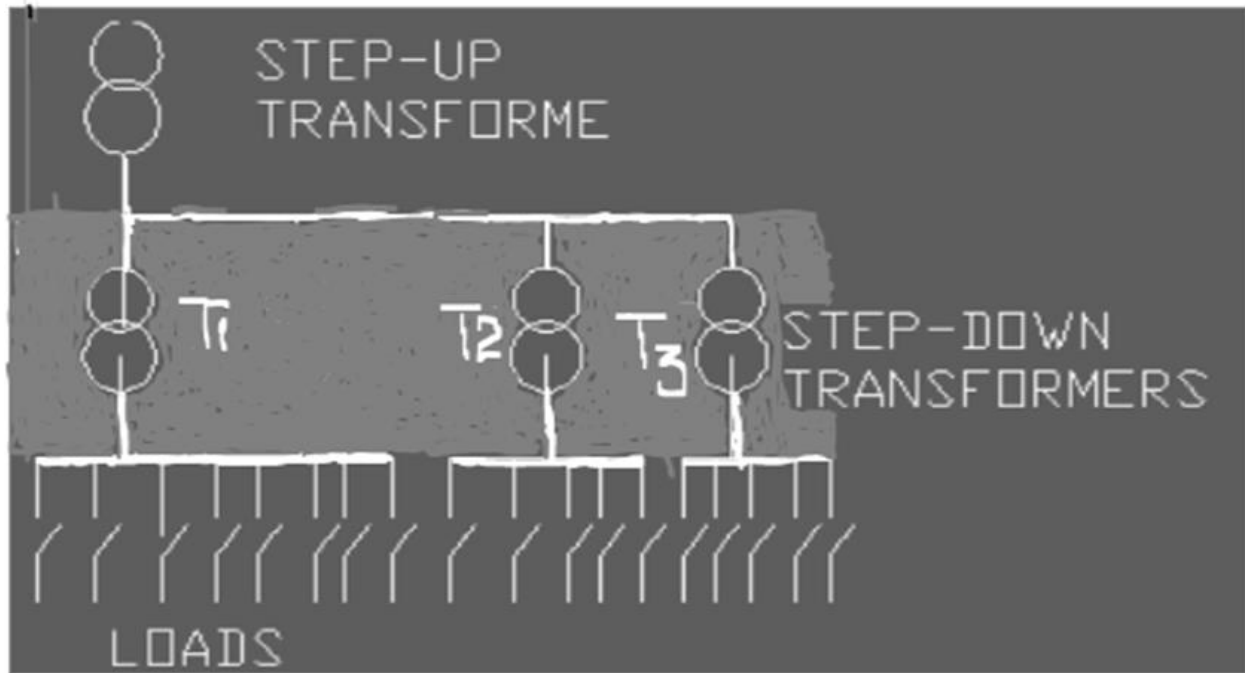

Figure 3. 1: One line diagram of power distribution system of Africa PLC

These transformers are:

1. Transformer supplying new Macaroni processing machineries (transformer 1)
2. Transformer supplying old Macaroni processing machineries (transformer 2)
3. Transformer supplying Pasta processing machineries (transformer 3)

3.2. Data Collection and Analysis

3.2.1. Sustained Interruption Data Analysis

The distribution substation has seven feeders of 15kV customer side voltage rating. This voltage is stepped down to 380V by factory service transformers. Since the industry is supplied directly from 15kV line, it is better to study the electric power interruption of the feeder from the substation.

From the monthly average interruption data shown in the Table, on appendix (B), the reliability indices are computed making use of equations (2.1) to (2.4).

Table 3.1: Reliability indices of 15 kV feeders at Adama Substation.

No	Feeders	Monthly Average No. of Interruptions	Monthly Average Interruption Duration(Hr)	SAIFI	SAIDI (Hr)	CAIDI (Hr)	ASAI
1	L1	22.25	23.96	22.25	23.96	1.07	0.96672
2	L2	20.25	20.43	20.25	20.43	1.0	0.97163
3	L3	18.25	21.5	18.25	21.5	1.18	0.97014
4	L4	25.75	22.03	25.25	22.03	0.87	0.96940
5	L5	3.25	10.28	3.25	10.28	3.16	0.98572
6	L6	11	15	11	15	1.36	0.97917
7	L7	12	13.19	12	13.19	1.1	0.98168

Table 3.2: Design target values of reliability indices on per-annum basis [17]

Design target values	
Indicator	Values
SAIFI	1
SAIDI	1-1.5Hr
CAIDI	1-1.5Hr
ASAI	0.99983

Comparing the values obtained from Table 3.1 above with the design target value tabulated in Table 3.2, the following conclusions can be drawn.

It can be observed that the system-average interruption frequency (SAIFI) of the feeders is extremely high when compared to the design target value. The target value is 1-interruption per-annum, while the monthly-average interruption frequency of the substation feeders reach 25.25. This will become 303 per annum. The minimum SAIFI is 39 which occurred on feeder L_6 . This shows even the minimum interruption frequency is much higher than the typical interruption frequency of the design target value. Therefore, the feeders are frequently interrupting.

Availability of all the feeders as observed from the ASAI values is below the typical target value, which is 0.99983. These indicate that the feeder lines get interrupted for a long duration of time.

Again from CAIDI, we can observe that all the feeders have large CAIDI value. The minimum CAIDI value is 0.87 hour per month. On yearly basis, it becomes 10.44 hour which is very high compared to the design target value (1-1.5hour). This means that the feeders require much time to restore service.

The computed values of the system average interruption duration indices (SAIDI) showed there is long duration of interruption when compared to the design target value. The minimum monthly average interruption duration is 10.28 hours. This becomes 123.36 hours of average interruption duration per annum. It shows that electric power is interrupted for a long period of time.

The results clearly show that the factory is facing serious power interruption problem. In order to alleviate the problem, the factory has been using standby generator of capacity 250KW. The thesis work did not consider a better option. It is better to use the existing generator in case of power interruption. The analysis has been done to give recommendation for the Ethiopian Electric Utility concerning the issue of frequent power interruption.

3.2.2. Voltage variation data Analysis

Figure (3.2), (3.3) and (3.4) below show RMS voltage variation of transformer supplying machineries of the new Macaroni, old Macaroni and Pasta processing section loads respectively. The data was taken during working hours of the factory. The graph shows the long duration voltage variation (under voltage) at different occasions.

Figure 3.2 shows RMS voltage variation graph taken from transformer supplying new Macaroni processing machineries. It shows single phase voltage variation along the RMS current of the system. As it can be seen from the figure, voltage variation is not significant during load variation; rather it comes from fault on the source side.

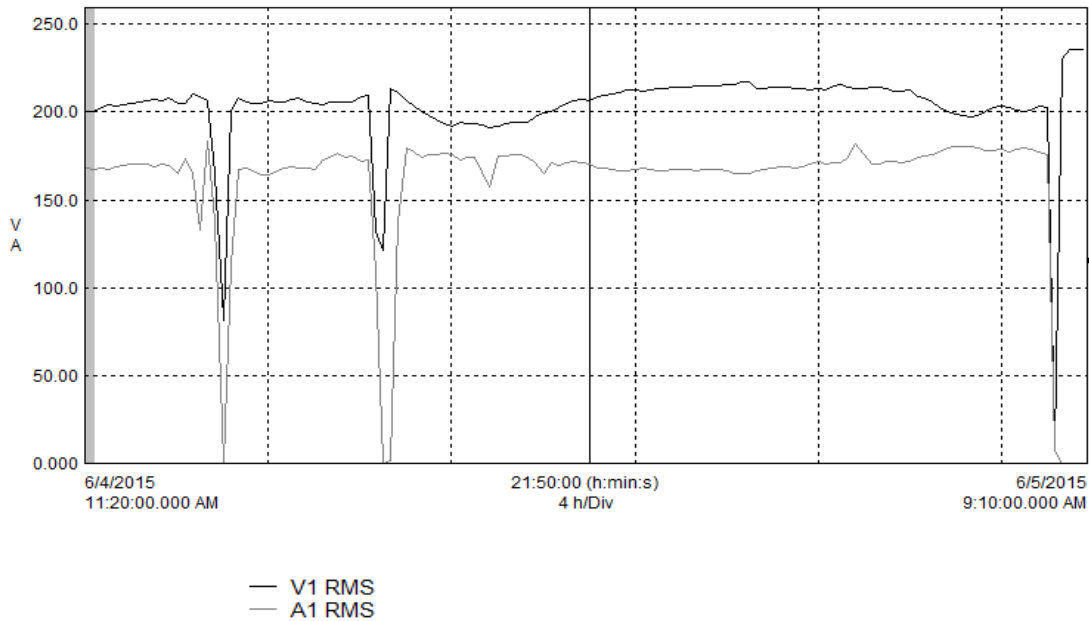

Figure 3.2: Voltage variation from transformer supplying new Macaroni processing machineries

Figure 3.3 shows RMS voltage variation graph taken from transformer supplying old macaroni processing machineries. Figure (3.3a) shows RMS three phase voltage variation while figure (3.3b) shows single phase voltage variation along the RMS current of the system. As it can be seen from figure (3.3b) voltage variation is not significant during load variation; rather it comes from source side again.

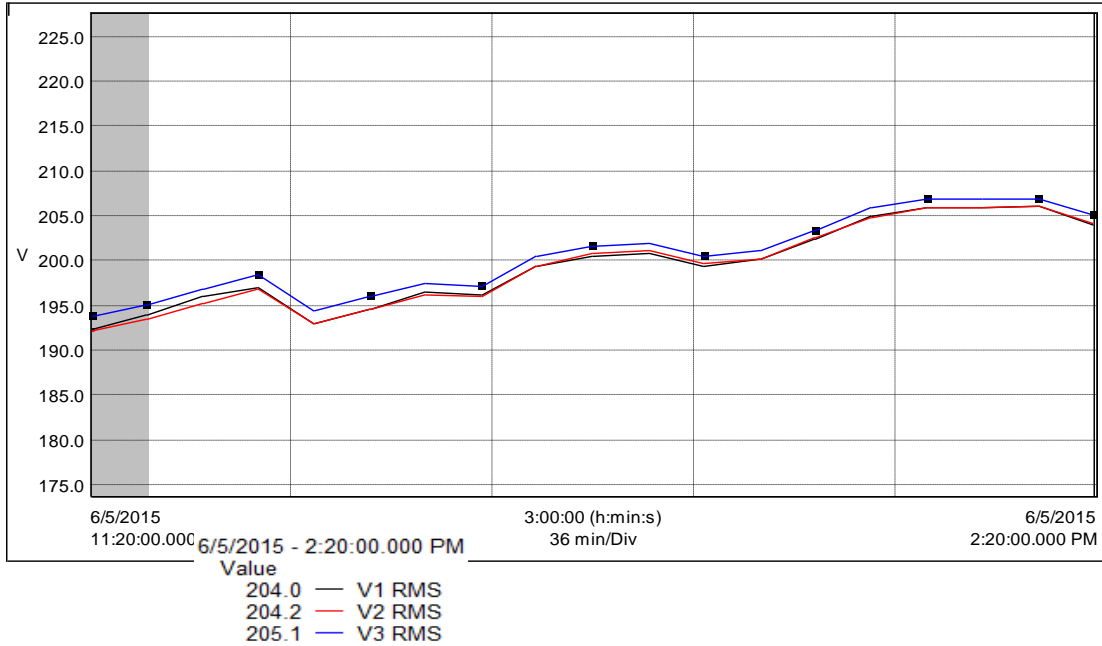

Figure 3.3a three phase voltage variation

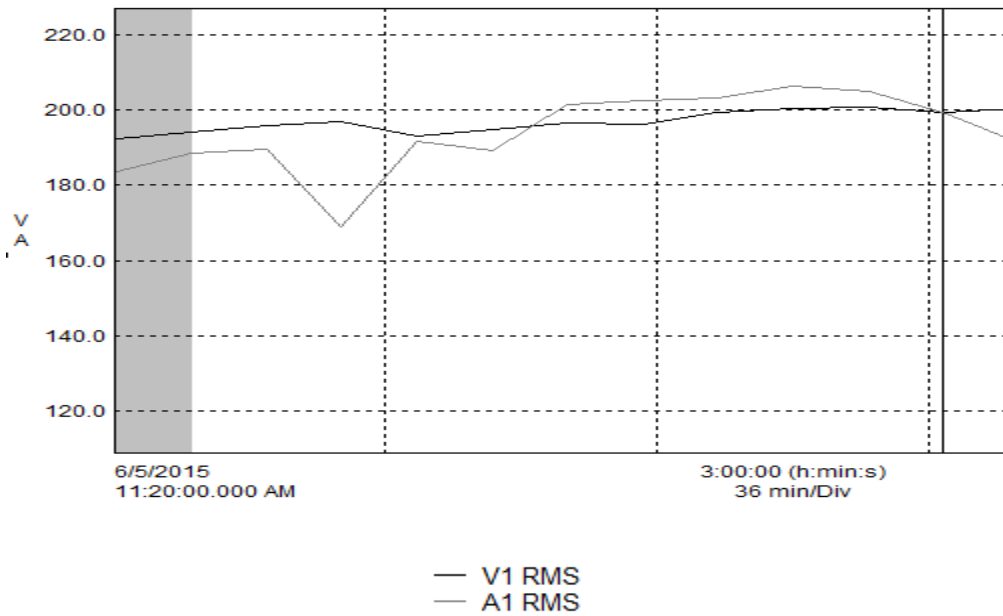

Figure 3.3b: single phase voltage and current variation

Figure 3.3: Voltage variations from transformer supplying old Macaroni processing machineries

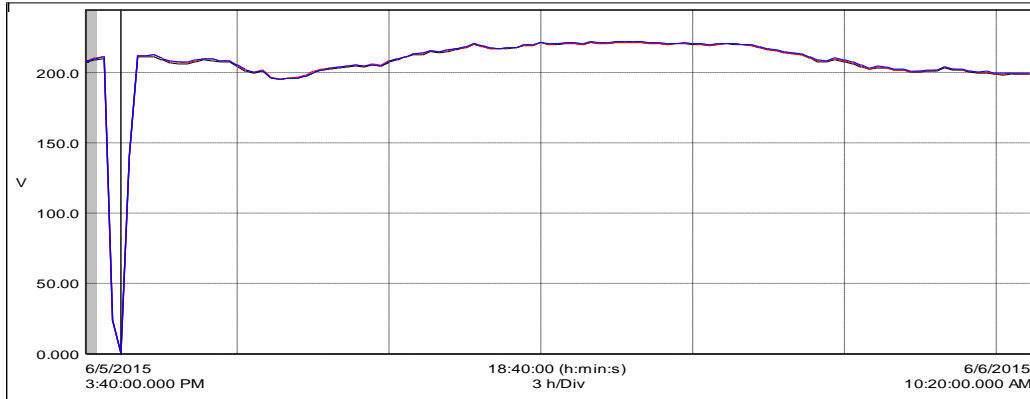

Figure 3.4a: RMS voltage variation

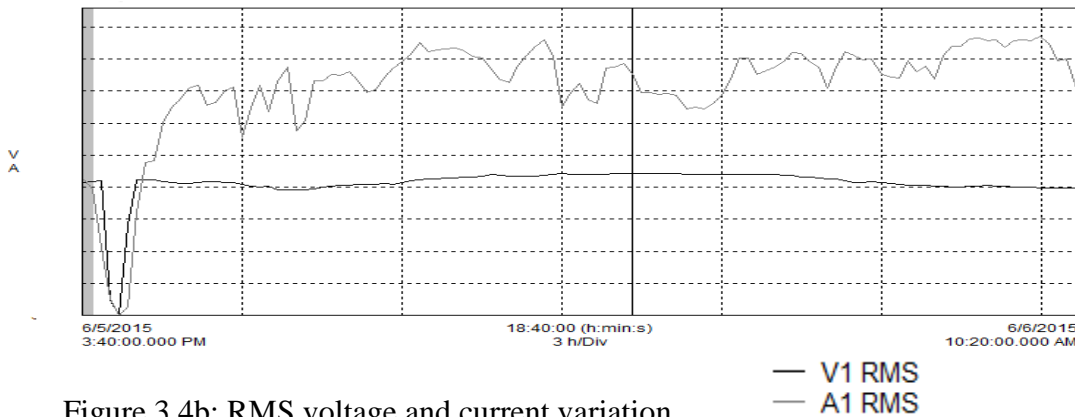

Figure 3.4b: RMS voltage and current variation

Figure 3.4: Voltage variation from transformer supplying Pasta processing machineries

The RMS voltage variation graph in figure (3.2), (3.3) and (3.4) show that under voltage found at different occasions has been not because of the load of the factory. The problem of under voltage has been not only when the factory is working at full load. This can be seen from figure 3.4b in which increment of the current did not affect RMS voltage. Therefore, the root cause of voltage variation is faults on distribution feeders and poor voltage regulation at the substation.

3.2.3. Wave form distortion data Analysis

3.2.3.1. Harmonic distortion standards

IEEE 519-1992 was developed to evaluate harmonic voltages and currents at a point of common coupling (PCC) between the end user and the utility supply system. The PCC is the location where another customer can be served from the system [5] [22]. The standard allows for the

same procedure to be applied by the customer at other locations within a facility but different current limit values could apply in these cases.

Table 3.3: Harmonic current limits for individual end users from IEEE standard 519-1992

V≤69kv						
I _{sh} /I _L	h<11	11<h<17	17<h<23	23<h<35	35<h	TDD
<20	4.0	2.0	1.5	0.6	0.3	5.0
20-50	7.0	3.5	2.5	1.0	0.5	8.0
50-100	10.0	4.5	4.0	1.5	0.7	12.0
100-1000	12.0	5.5	5.0	2.0	1.0	15.0
>1000	15.0	7.0	6.0	2.5	1.4	20.0

Whereas:

I_{SC} - Short circuit current at the point of common coupling.

I_L - Maximum demand loads current (fundamental frequency component) at the point of common coupling. It can be calculated as the average of the maximum monthly demand currents for the previous 12 months or it may have to be estimated. All power generation equipment applications are limited to these values of current distortion regardless of the actual short circuit ratio I_{SC}/I_L.

$$I_L = \frac{p}{\sqrt{3} * PF * KV} \quad (3.1)$$

$$I_{SC} = \frac{U_{20}}{\sqrt{3} * Z_T} \quad (3.2)$$

$$\text{Short circuit ratio} = \frac{I_S}{I_L} \quad (3.3)$$

Whereas:

U₂₀ - Nominal voltage with the secondary side of transformer open

I_{sc} - Short circuit current of the transformer

%Z - Percentage transformer impedance

P - Load demand

PF - Power Factor

The tables of individual harmonic component limits apply to the odd harmonic components.

Even harmonic components are limited to 25% of the limits in the tables.

Current distortion which results in a dc offset is not allowed.

The total Demand Distortion (TDD) as defined previously;

$$TDD = \frac{\sqrt{\sum_{h=2}^{h_{max}} I_h^2}}{I_L} \quad (3.4)$$

Whereas:

I_h - Magnitude of individual harmonic components (RMS, amps)

H - Harmonic order

I_L - Maximum demand load current (RMS amperes) defined above.

If the harmonic producing loads consist of power converters with pulse number (q) higher than six, the limits indicated in the table are increased by a factor equal to $\sqrt{\frac{q}{6}}$ provided that the magnitudes of the no characteristic harmonics are less than 25% of the limits specified in the table.

Table 3.4: Harmonic voltage limits, IEEE standard 519-1992

Utility bus voltage	Maximum individual harmonic component (%)	Maximum THD (%)
<69kv	3.0	5.0
39kv to 137.9kv	1.5	2.5
138 and above	1	1.5

IEEE Standard for Shunt Power Capacitors (IEEE Standard 18-1992) specifies the following continuous capacitor ratings:

- 135 percent of nameplate kVAr
- 110 percent of rated RMS voltage (including harmonics but excluding transients)
- 180 percent of rated RMS current (including fundamental and harmonic current)

- 120 percent of peak voltage (including harmonics)

3.2.3.2. Data collected from transformer 1 at full load

The graph below shows the variation of voltage and current total harmonic distortion (THD) per phases. The vertical axis shows percentage of total harmonic distortion on the fundamental component and the horizontal axis shows time duration of measurement. The upper graphs show THD for current and the lower shows THD for voltage. The value indicated under the graph is the value at the particular time.

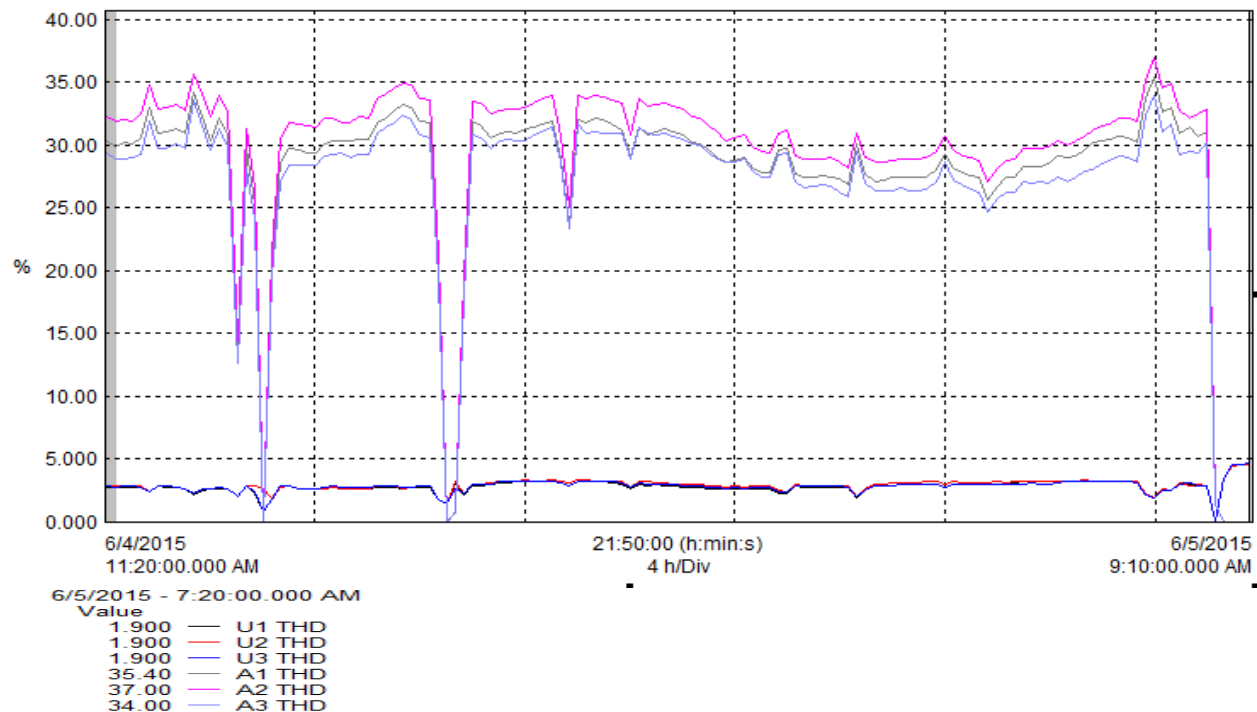

Figure 3.5: THD_v and THD_i from transformer 1 at full load

The data has been gathered for about twenty two hours during working hours of the factory. The horizontal division shows four hour per column as it can be seen from the graph. The graph trend shows harmonic distortion level during different loading condition and different voltage variation. The distortion becomes zero at some points on the graph which shows system was turned off due to under voltage condition. This can be clearly understood by comparing the distortion trend to the voltage variation trend shown on the figure 3.2. The main sources of the current harmonic distortion in the factory is Adjustable Speed Drive (ASD). The harmonic current distortion in

adjustable-speed drives is not constant [22]. The waveform changes significantly for different speed and torque values. So during full load condition also the THDI and THDV varies slightly.

Table 3.5: Voltage data from transformer supplying new Macaroni machineries at full load

No. of measurement	Frequency	V1 RMS	V2 RMS	V3 RMS	V1 THD	V2 THD	V3 THD	V Unbalance
	Hz	V	V	V	%	%	%	%
1	50.1	200	199	198.9	2.6	3	3	0.3
2	50.1	200.6	199.6	199.6	2.6	2.9	3	0.2
3	50	202.4	201.3	201.4	2.7	3	3	0.2
4	50.1	204.4	203.4	203.6	2.7	3	3	0.2
5	50.1	203.3	202.2	202.3	2.7	2.9	3	0.2
6	50.1	204.5	203.5	203.7	2.3	2.5	2.5	0.2
7	50.1	204.9	203.8	203.9	2.7	3	3	0.2
8	50.1	206.1	205	205.1	2.7	2.9	3	0.2
Average	50.1	203	202	202	2.6	2.9	2.9	0.2

The table shows the voltage distortion level and RMS value of each phase taken from the transformer of the feeder of new Macaroni processing section; the measurement on individual phases. The average full load measurement shows that the THDv is 2.6%, 2.9% and 2.9% for the respective phases. As per IEEE standard the voltage distortion should be below 3% for individual harmonic components and below 5% for total harmonic distortion. The figure in the table implies there is no sign of significant voltage distortion.

The voltage unbalance limit at the terminal of the motors in the industry should be below 1% as per IEEE standard. The unbalance greater than 1% makes motor operation difficult in which the motors are over heated and forced to function below their rated power. Again the measurement taken at the terminal of the motors indicates the voltage unbalance is not beyond the standard. The average measured supply frequency is 50.1 Hz which in is the range of acceptable limit

Table 3.6: The average RMS current, THD_I current unbalance taken from the transformer 1 at full load

No. of measurement	A1 RMS	A2 RMS	A3 RMS	A1 THD	A2 THD	A3 THD	A Unbalance
	A	A	A	%	%	%	%
1	167.5	170.6	166.4	30.1	31.9	29	0.8
2	169	171.5	167.3	30.6	32.5	29.3	0.8
3	169.4	171.7	167.8	33	34.8	31.9	0.9
4	170.1	173	168.4	31	32.9	29.7	0.9
5	170.4	172.8	169	31.1	33	29.8	0.7
6	170.5	172.6	169	31.3	33.2	30.1	0.6
7	169	171	167.4	30.9	32.8	29.8	0.7
8	170.4	170.7	170.2	34.2	35.7	33.6	0.6
Average	170	171	168	31.5	34.4	30.4	0.75

The table 3.6 shows RMS current, THD_I per phase and unbalances between the phases for different readings. The reading in the table shows average values of the parameters at the bottom. The average current unbalance value is 0.75% which is not beyond limit value given by standard, 10%. But the THD_I measured shows there is high value of distortion.

The bar graph of figure 3.5 shows the individual current harmonic components for each phase: 1, 2, and 3 with their distortion level in percentage. The horizontal line of the bar graph contains odd harmonic number from 1 to 21 and the number 123 which represents phase numbers. As it can be seen from the graph the 5th and the 7th harmonic distortions are the dominant on this transformer.

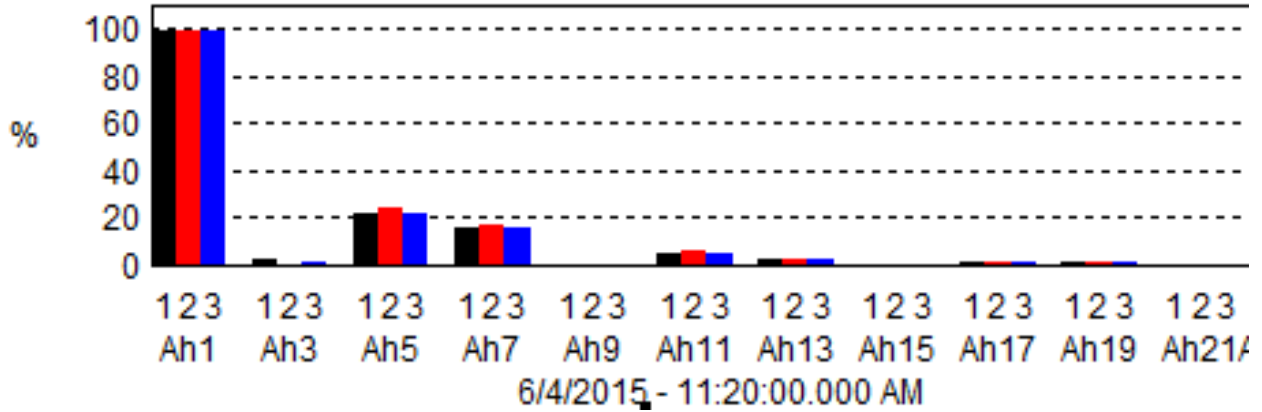

Figure 3.6: Current harmonic components measured from transformer 1

Analysis of harmonic currents and voltages data from transformer 1.

The total average current harmonic distortions for different reading are presented for each phases in Table 3.6. THD_I for phase one, phase two and phase three are 31.5%, 34.4% and 30.4% respectively and the THD_V is 2.6%, 2.9% and 2.9% for phase one , phase two and phase three respectively. RMS value of individual harmonic components for current and voltage from appendix [A] can be tabulated as follows Table (3.7).

Table 3.7: RMS value of individual harmonic currents and voltages from transformer 1

Harmonic components	h=1	h=3	h=5	h=7	h=11	h=13	h=17
RMS current(pu)	1	0.01875	0.25	0.225	0.0356	0.01863	0.01875
Voltage (pu)	1	0	0.0140	0.0170	0.0100	0.0040	0.0048

From the above table, the harmonics existing in the system can be simulated using mathematical expression of harmonics expressed in equation (2.10). The equation is rewritten again in equation (3.5).

$$f(t) = \sum_{h=1}^{h_{max}} A_h \sin(2\pi h f_o t + \varphi_h) \tag{3.5}$$

The distorted and individual harmonic spectral components wave forms have simulated on figure (3.7), (3.8), (3.9) and (3.10) below. The harmonic numbers greater than 17th are neglected since they are not significant.

Figure (3.7) shows the simulated distorted voltage wave form on the transformer supplying new Macaroni processing machineries. And figure (3.8) shows voltage spectral harmonic components on the same transformer. As it can be seen from the wave forms the voltage distortion is not significant.

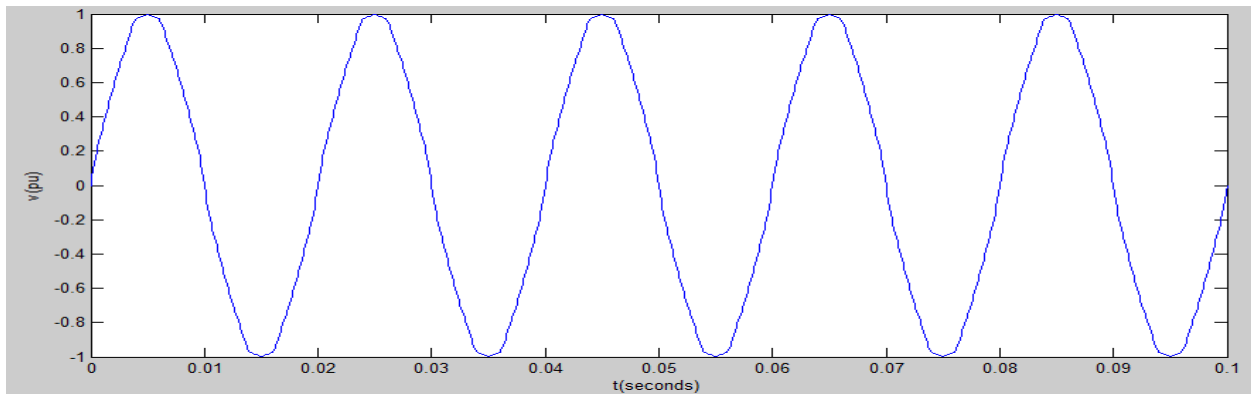

Figure 3.7: Simulation of distorted waveform of single phase voltage for transformer 1

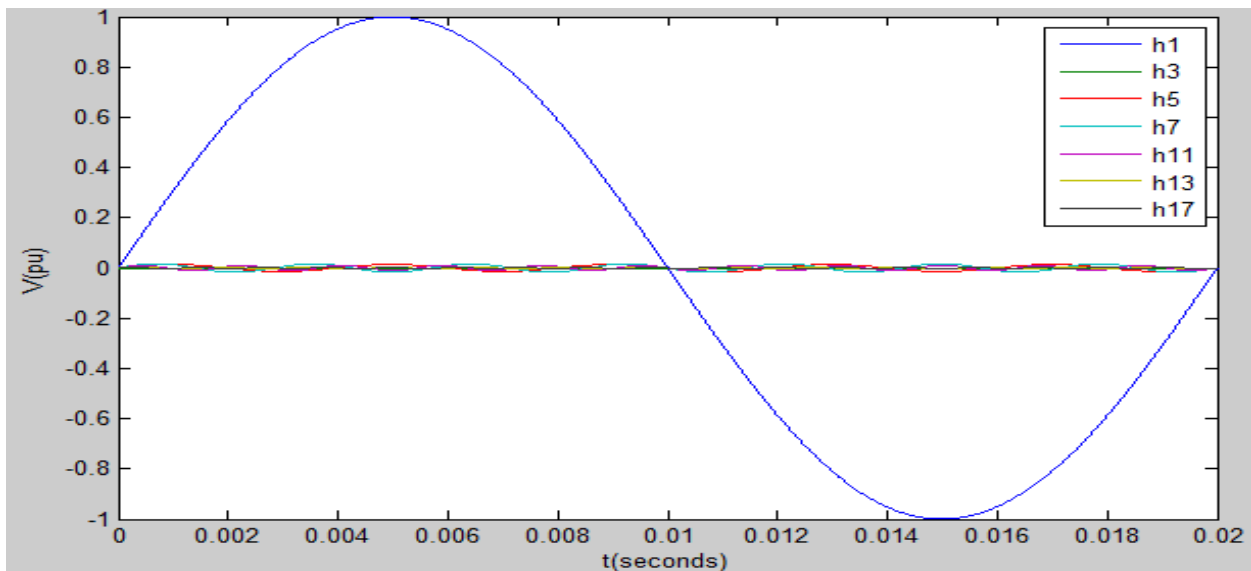

Figure 3.8: Harmonic spectral components of single phase voltage for transformer 1

Figure (3.9) shows the simulated distorted current wave form on the transformer supplying new macaroni processing machineries. And figure (3.10) shows current spectral harmonic

components on the same transformer. As it can be seen from the simulated graph the current harmonics are the main problems in the factory with the dominant 5th and 7th harmonics.

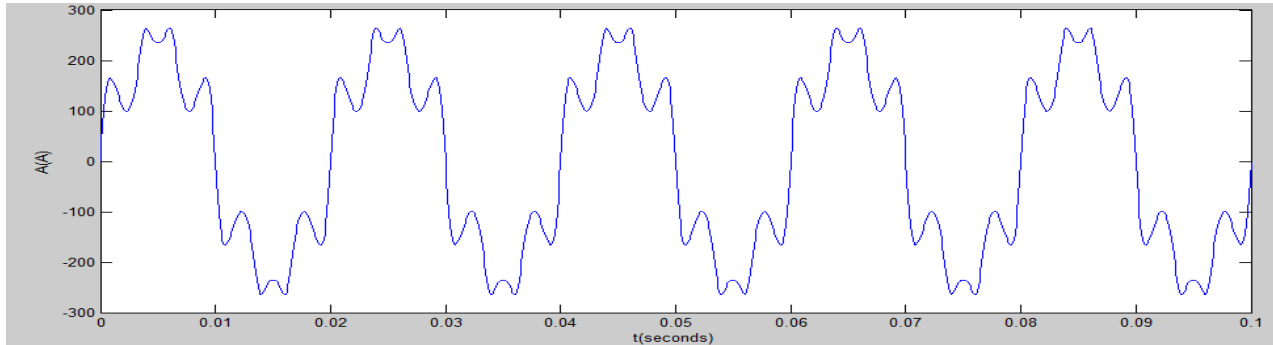

Figure 3.9: Simulation of single phase distorted current wave for transformer 1

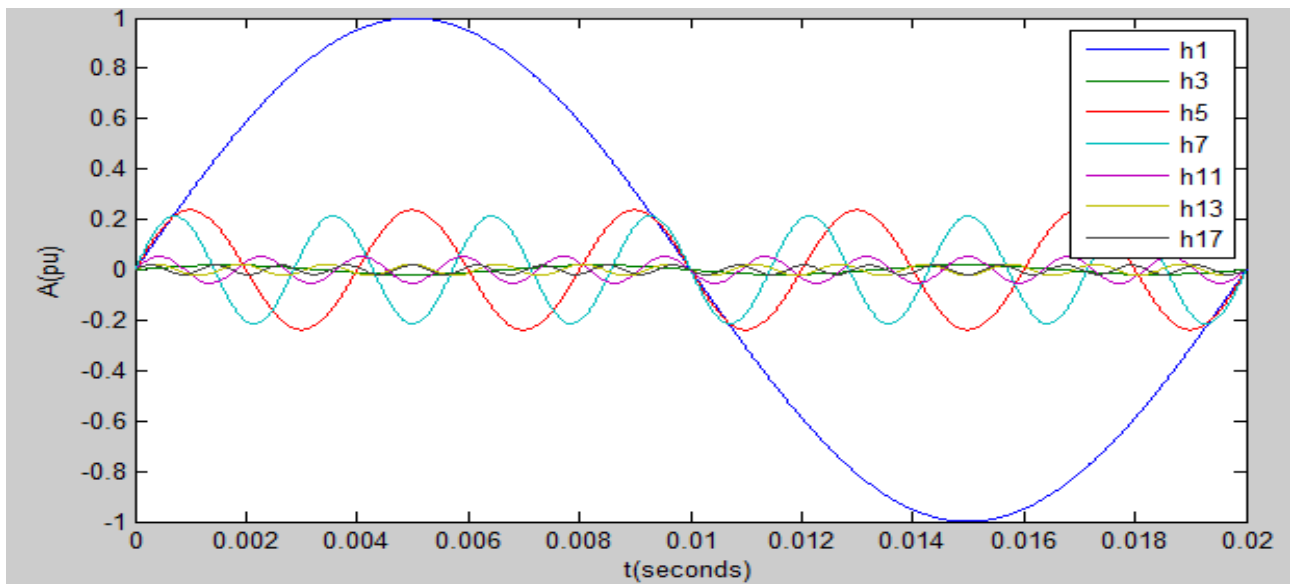

Figure 3.10: Harmonic spectral components of single phase current for transformer 1

Figure 3.10 shows simulation of RMS current harmonic spectral components tabulated in appendix A. The dominant harmonic components are 5th, 7th and harmonic orders 25% and 20% respectively.

We can take transformer impedance (6%) from its name plate, total load demand from the measured value and line to line voltage to calculate the harmonic limits. Using equation (3.1), (3.2) and (3.3) to calculate the short circuit ratio, the load current is 156A and short circuit current is 2116A. The short circuit ratio becomes 13.56 which is in the first row of IEEE harmonic current distortion standard shown in table (3.1). According to the standard, TDD_1

should be below 5% and individual current demand distortion should be below 4% (for harmonic orders less than 11th). This measured value shows the harmonic current distortion level is beyond standard and should be mitigated.

Table 3.8: Average real power and power factor data measured on transformer 1

Average Power					Average Power Factor			
W1	W2	W3	W total	VA total	PF1	PF1	PF3	PF mean
27994.45	27952	27658.85	83605.3	102709.17	0.822	0.806	0.814	0.814

Table (3.8) shows single phase and three phase average real power, apparent power and power factor reading as indicated in the table. As the data taken from the transformer implies the average power factor of the three phases is low, 0.814. The factory has been penalized by Ethiopian Electric Utility (EEU) for the low power factor. Therefore the power factor should be corrected so that the efficient use of power is ensured and also for factory to escape from penalty.

3.2.3.3. Data collection from transformer supplying old Macaroni processing machineries

The figure (3.11) shows the variations of voltage and current total harmonic distortion per phase from transformer supplying old macaroni processing machineries. The graph shows both voltage and current total harmonic distortion (THD) for phase1, phase2 and phase 3 as differentiated with the color coding.

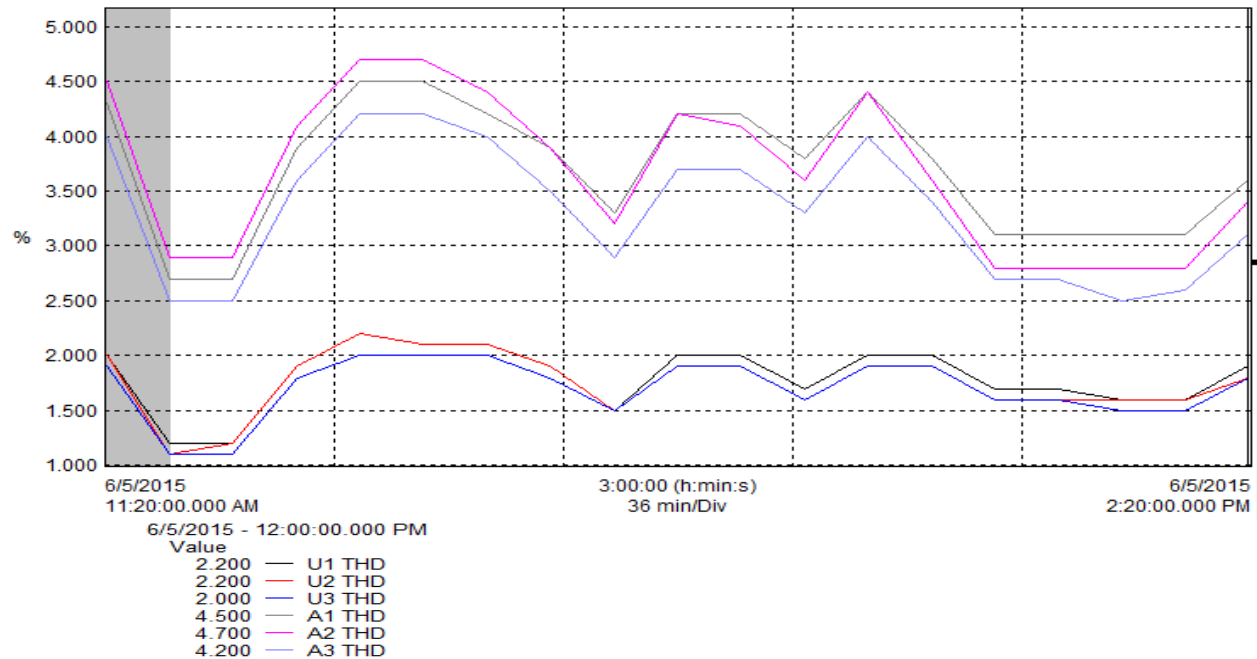

Figure 3.11: THD_v and THD_i from the transformer 2

The upper graph shows current total harmonic distortion and the lower shows the voltage total harmonic distortion. The vertical axis shows percentage of total harmonic distortion on the fundamental component and the horizontal axis shows time duration of measurement. The value under the graph shows the measured parameter at particular time. The horizontal division shows thirty six minutes per column as it can be seen from the graph. In this case the value represents the measurement made in the beginning. The main sources of the current harmonic distortion in the factory is ASD as explained already. The harmonic current distortion in adjustable-speed drives is not constant. The waveform changes significantly for different speed and torque values.

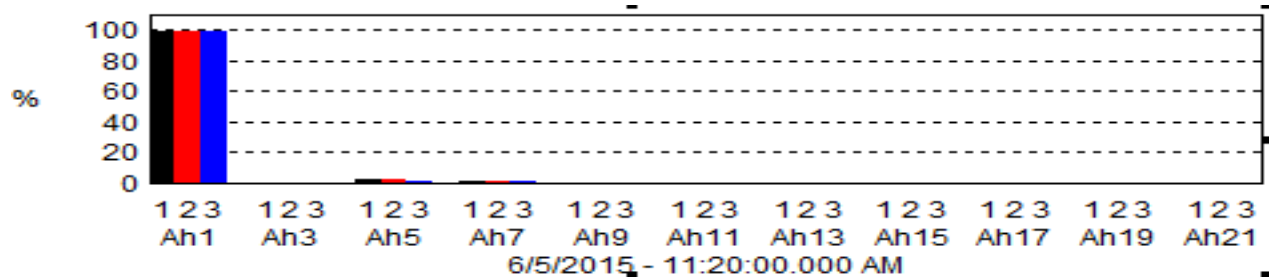

Figure 3.12: Individual current harmonic distortions from transformer 2

The graph shows the individual harmonic components for the respective phases with their distortion level in percentage to the fundamental current. The horizontal line of the bar graph contains odd harmonic number from 1 to 21 and the number 123 which represents phase numbers. As it can be seen from figure 3.12, harmonic distortions are very low. Only the 5th and 7th harmonics are visible on each phase of this figure. This is because most of the motors in this section are controlled simply by breaker. Only some motors are controlled by speed drives. These harmonics are not significant compared to the standard.

Table 3.9: RMS current, THD₁ and voltage unbalance from transformer 2

Number of measurement	A1	A2	A3	A1	A2	A3	Current Unbalance
	RMS	RMS	RMS	THD	THD	THD	
	A	A	A	%	%	%	%
1	183.7	183.7	196.4	4.3	4.5	4	4.40
2	188.4	186.1	200.1	2.7	2.9	2.5	4.16
3	189.6	185	200.3	2.7	2.9	2.5	4.30
4	168.9	168.5	179.8	3.9	4.1	3.6	4.50
5	191.6	191.6	204.2	4.5	4.7	4.2	4.18
6	189.4	188	200.5	4.5	4.7	4.2	3.90
7	201.6	199.3	210.6	4.2	4.4	4	3.70
8	202.6	201.5	211.9	3.9	3.9	3.5	3.36
Average	189	187	200	3.8	3.9	3.6	4.17%

Table 3.9 shows RMS current, THD_I per phase and unbalances between the phases for different readings. The reading in the table shows average values of the parameters at the bottom. The average current unbalance value is 4.17% which is not beyond limit value given by standard, 10%. The THD_I measured also shows there is low value of distortion compared to the standard. The standard limits the THD_I to as explained previously in Table 3.3.

Table 3.10: RMS voltage, THD_v and voltage unbalance from transformer 2

No. of measurement	V1	V2	V3	V1	V2	V3	V
	RMS	RMS	RMS	THD	THD	THD	Unbalance
	V	V	V	%	%	%	%
1	196.2	196	197.2	2	1.8	1.8	0.6
2	199.5	199.5	200.5	1.6	1.5	1.4	0.25
3	200.5	200.9	201.7	2.1	1.9	1.9	0.34
4	200.9	201.2	202	2.1	1.9	1.9	0.49
5	199.5	199.8	200.5	1.8	1.6	1.6	0.25
6	200.3	200.3	201.2	2.1	1.9	1.9	0.1
7	202.5	202.6	203.4	2.2	1.9	1.9	0.19
8	205	204.9	205.9	1.8	1.6	1.6	0.43
Average	200.5	200.6	201.5	1.9	1.7	1.8	0.33

Table 3.10 shows the voltage distortion level and RMS value measured from transformer supplying the old Macaroni processing machineries. The average measurement during full load shows the THD_v is 1.90%, 1.70% and 1.8% for phase one, phase two and phase three respectively. As per IEEE standard, the voltage distortion should be below 3% for individual harmonic components and below 5% for total harmonic distortion. The results in the table indicate that there is a voltage distortion which is in acceptable range. The voltage unbalance limit at the terminal of the motors in the industry should be below 1% as per IEEE standard. The unbalance greater than 1% makes motor operation difficult in which the motors are over heated

and forced to function below their rated power as described previously. Again the measurement taken indicates the voltage unbalance is not beyond the standard.

Analysis of harmonic current and voltage data for transformer 2

From the table below, the harmonics existing in the system can be simulated using mathematical expression of harmonics expressed in equation (2.10). The distorted and individual harmonic component wave forms have simulated as shown below figures (3.13), (3.14), and (3.15). The harmonic numbers greater than 17th are neglected since they are not significant.

Table 3.11: RMS value of individual harmonic currents and voltages from transformer 2

Harmonic components	h=1	h=3	h=5	h=7	h=11	h=13	h=17
Current (pu)	1	0	0.01	0.01	0.006	0.0026	0.0028
Voltage (pu)	1	0.003	0.03	0.02	0.008	0.004	0.002

Figure (3.13) shows the simulated distorted voltage wave form on the transformer supplying old macaroni processing machines. And figure (3.14) shows voltage spectral harmonic components on the same transformer. As it can be seen from the wave forms on the figures (3.13), (3.14), and (3.15) there is no significant current and voltage distortions on this transformer.

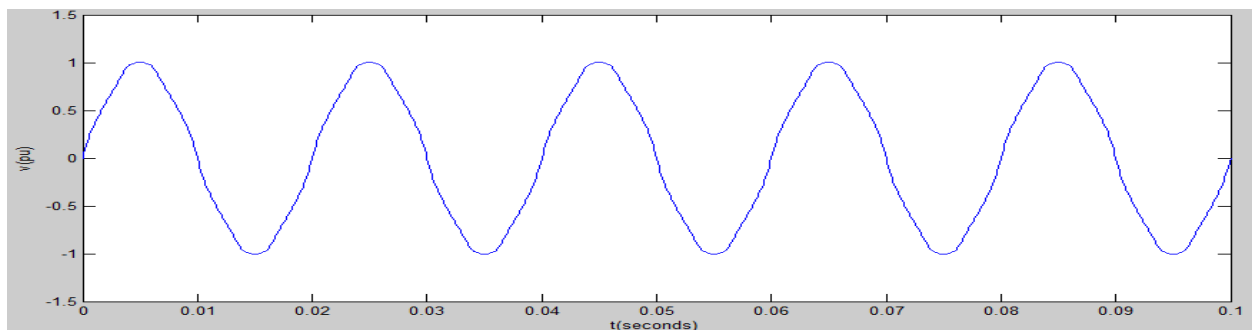

Figure 3. 13: Waveform of distorted single phase voltage for transformer 2

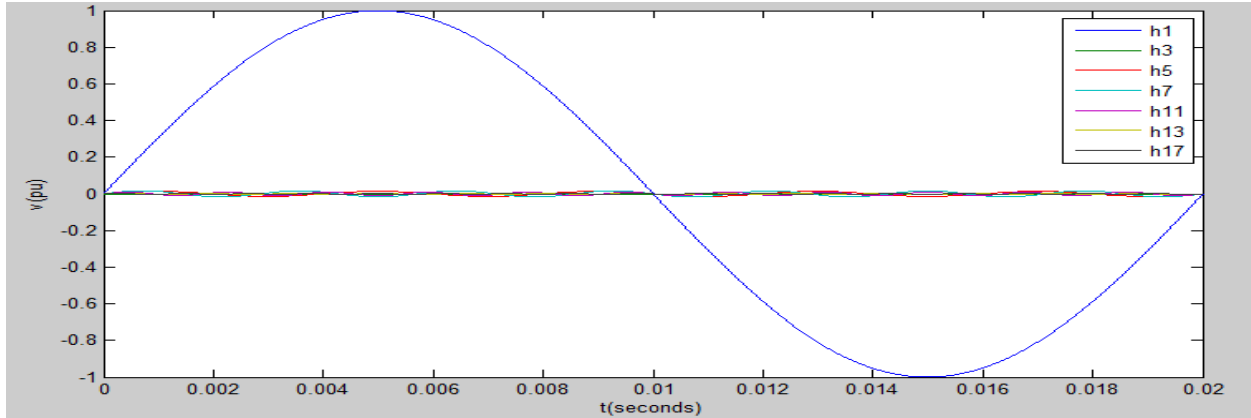

Figure 3.14: Spectral harmonic components of single phase voltage for transformer 2

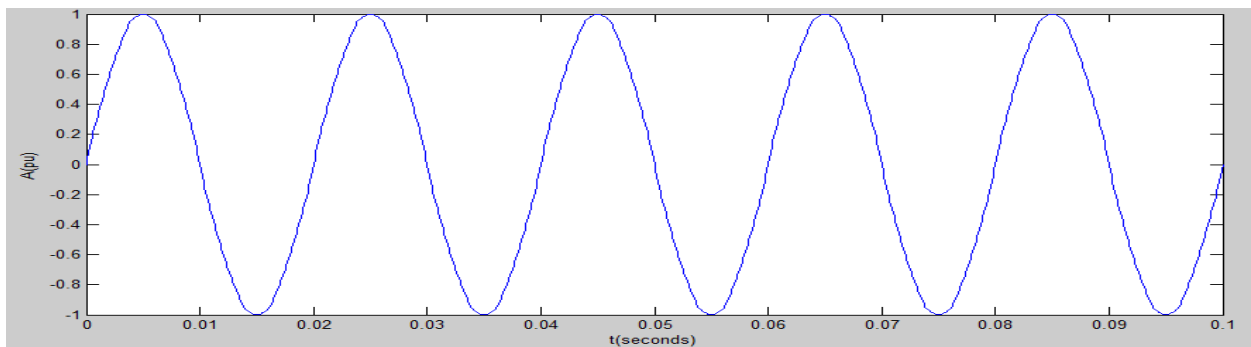

Figure 3.15: Waveform of single phase current for transformer 2

Table 3.12: Frequency, Real power and Power factor data measured from transformer 2

Frequency		Average power					Average Power factor			
Hz		W1	W2	W3	W total	VA Total	PF1	PF1	PF3	PF mean
Min	Max									
49.8	50.1									
49.9		13,506	12,853	11,958	38,317	57,673	0.82	0.749	0.74	0.768

The table3.12 shows single phase and three phase average real power, apparent power and power factor reading as indicated in the table. As the data taken from the transformer implies the average power factor value is 0.768 which is low. The Ethiopian Electric Utility has been

penalizing the factory for the low power factor which is a problem for the factory. Therefore the power factor should be corrected so that the efficient use of power is ensured and power factor penalty also reduced for the factory.

3.2.3.4. Data collection from the transformer supplying Pasta processing machineries

The graph below shows the trend of voltage and current total harmonic distortion per phase from transformer supplying Pasta processing machineries. The graph shows both voltage and current total harmonic distortion (THD) for phase1, phase2 and phase 3 as differentiated with the color coding. The upper graph shows current total harmonic distortion and the lower shows the voltage total harmonic distortion. The vertical axis shows percentage of total harmonic distortion on the fundamental component and the horizontal axis shows time duration of measurement. The horizontal division shows three hour per column as it can be seen from the graph.

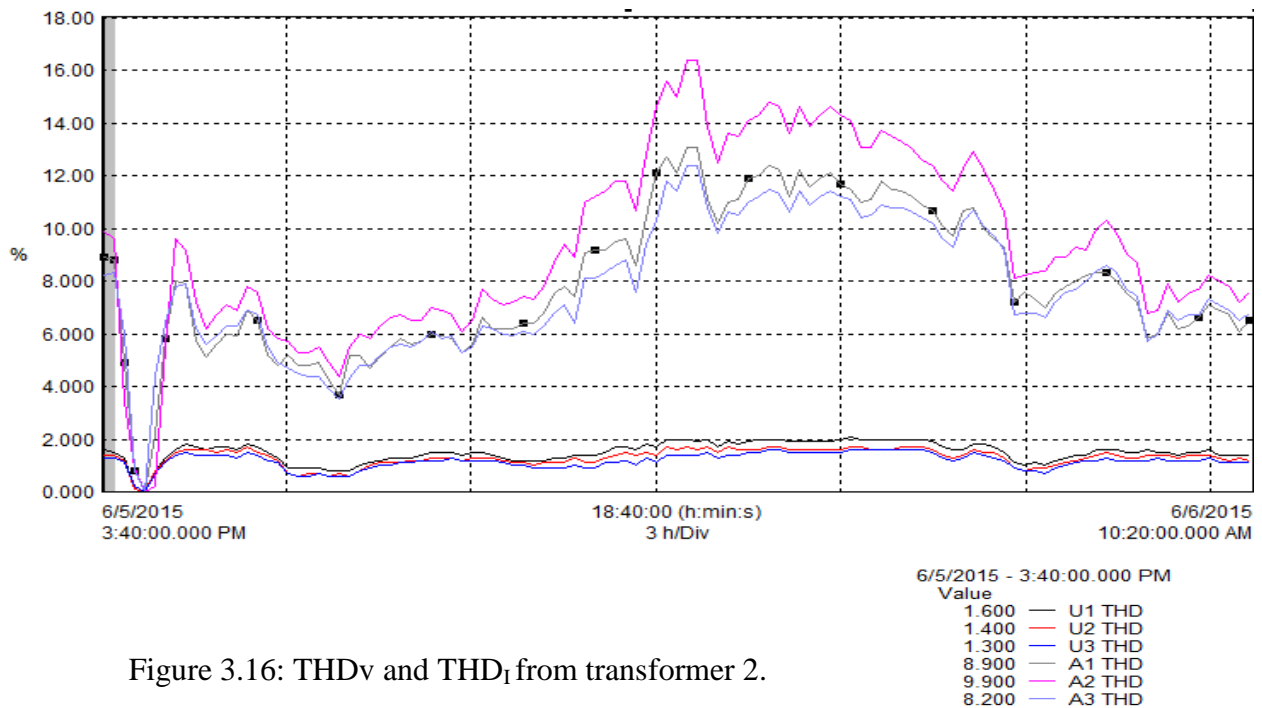

Figure 3.16: THD_v and THD_i from transformer 2.

The value under the graph shows the measured parameter at particular time. In this case the value represents the measurement made in the beginning as it can be understood from the given time above the measured value. The data has been gathered for about fourteen hours during working hours of the factory. The graph trend shows harmonic distortion level during different

loading condition and different voltage variation. The distortion becomes zero at some points on the graph which shows system was turned off due to under voltage condition and the distortion becomes very high at full load when all non linear loads are on function.

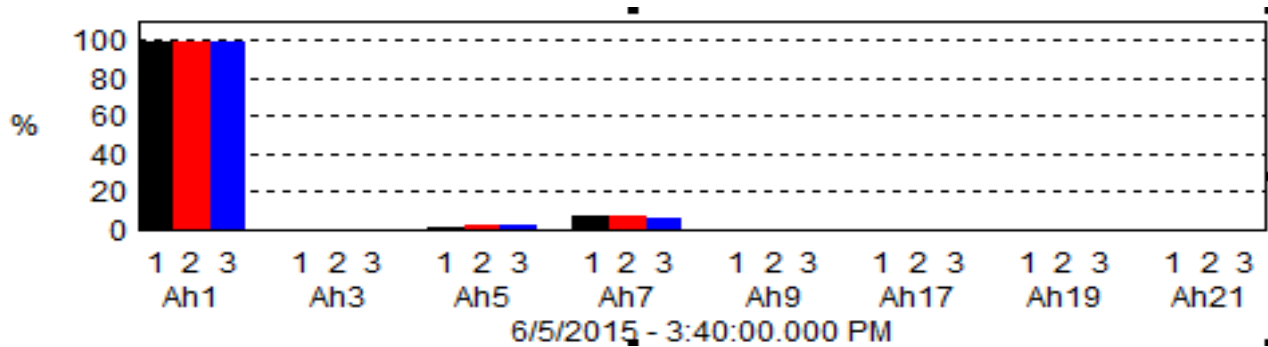

Figure 3.17: Individual current harmonic distortions from transformer 3.

The bar graph shows the individual harmonic components for each phase: 1, 2, and 3 with their distortion level in percentage on to the fundamental current. The horizontal line of the bar graph contains odd harmonic number from 1 to 21 and the number 123 which represents phase numbers. As it can be seen from the graph (3.17) the 5th and 7th harmonics are dominant harmonic components with the 7th harmonic more dominant.

Table 3.13: RMS voltage, THDv and voltage unbalance from transformer 3

No. of measurement	V1	V2	V3	V1	V2	V3	Voltage unbalance
	RMS	RMS	RMS	THD	THD	THD	
	V	V	V	%	%	%	%
1	207.5	208.5	208.3	1.4	1.5	1.3	0.2
2	209.1	210.2	210	1.4	1.5	1.3	0.2
3	210	211.1	211.2	1.2	1.3	1.1	0.3
4	139.9	140.7	140.7	0.7	0.8	0.7	0.3
5	211.2	212	212.3	1.2	1.4	1.1	0.3
6	211.2	212.2	212.3	1.5	1.7	1.4	0.3
7	211.4	212.5	212.6	1.6	1.8	1.5	0.3
8	208.8	209.7	210.1	1.5	1.8	1.5	0.3
Average	201	202	202	1.3	1.5	1.2	0.28

Table (3.13) shows the voltage distortion level and RMS value of each phase taken from the transformer supplying Pasta processing machineries. The average full load measurement shows the THD_v is 1.3%, 1.5% and 1.2% for phase one, phase two and phase three respectively. As per IEEE standard the voltage distortion should be below 3% for individual harmonic components and below 5% for total harmonic distortion. The figure in the table implies there is no sign of voltage distortion. The voltage unbalance limit at the terminal of the motors in the industry should be below 1% as per IEEE standard and the unbalance greater than 1% makes motor operation difficult in which the motors are over heated and forced to function below their rated power as explained already under transformer supplying new macaroni processing machineries. Again the measurement indicates the voltage unbalance is not beyond the standard.

Table 3.14: RMS current, THDI and voltage unbalance from transformer 2

No. of Measurement	A1 RMS	A2 RMS	A3 RMS	A1 THD	A2 THD	A3 THD	Current Unbalance
1	205.2	201.3	216.8	9.5	11.8	8.6	2.3
2	220.8	217.5	230.8	9.6	11.8	8.8	2.1
3	230.7	227	238.9	8.6	10.7	7.6	1.9
4	204.8	201.2	213.1	10.4	12.8	9.4	2.1
5	124.4	122	130.8	12.1	14.6	10.3	2.1
6	148.4	147.1	157	12.7	15.6	11.8	2.1
7	162.4	161.8	171.5	12.1	15	11.4	2
8	186.7	185.4	194.7	11.1	13.9	10.8	1.7
Average	185	183	194	10.8	13	10	2

Analysis of harmonic current and voltage data from transformer supplying Pasta processing machineries

The total average current harmonic distortions for different reading are presented for each phases in Table (3.14). THD_i for phase one, two and three are 10.8%, 13% and 10% respectively. The

RMS value of individual harmonic components for current and voltage were put on appendix [A] and can be can be tabulated as follows table (3.15).

Table 3.15: RMS value of individual harmonic currents and voltage from transformer 3

Harmonic components	h=1	h=3	h=5	h=7	h=11	h=13	h=17
RMS current (pu)	1	0.016	0.06	0.11	0.027	0.0081	0.016
Voltage (pu)	1	0	0.012	0.006	0.0003	0	0

From the above table, the harmonics existing in the system can be simulated using mathematical expression of harmonics expressed in equation (2.10).

The distorted and individual harmonic component wave forms have simulated as shown below figure (3.18), (3.19), (3.20) and (3.21). Again the harmonic numbers greater than 17th are neglected since they are not significant.

Figure (3.18) shows the simulated distorted voltage wave form on the transformer supplying Pasta processing machines. And figure (3.18) shows voltage spectral harmonic components on the same transformer. As it can be seen from the wave forms on the figures (3.18) and (3.19), there is no significant voltage distortions on this transformer.

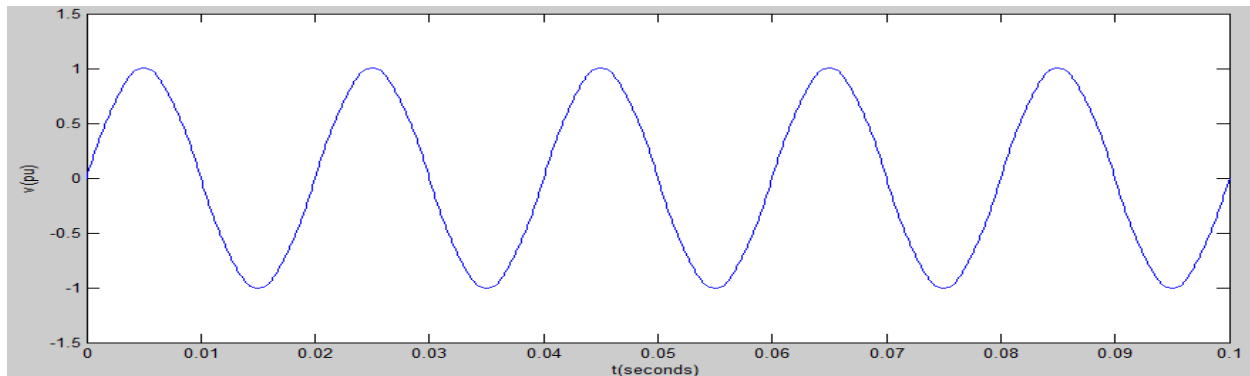

Figure 3.18: Distorted voltage wave for transformer 3.

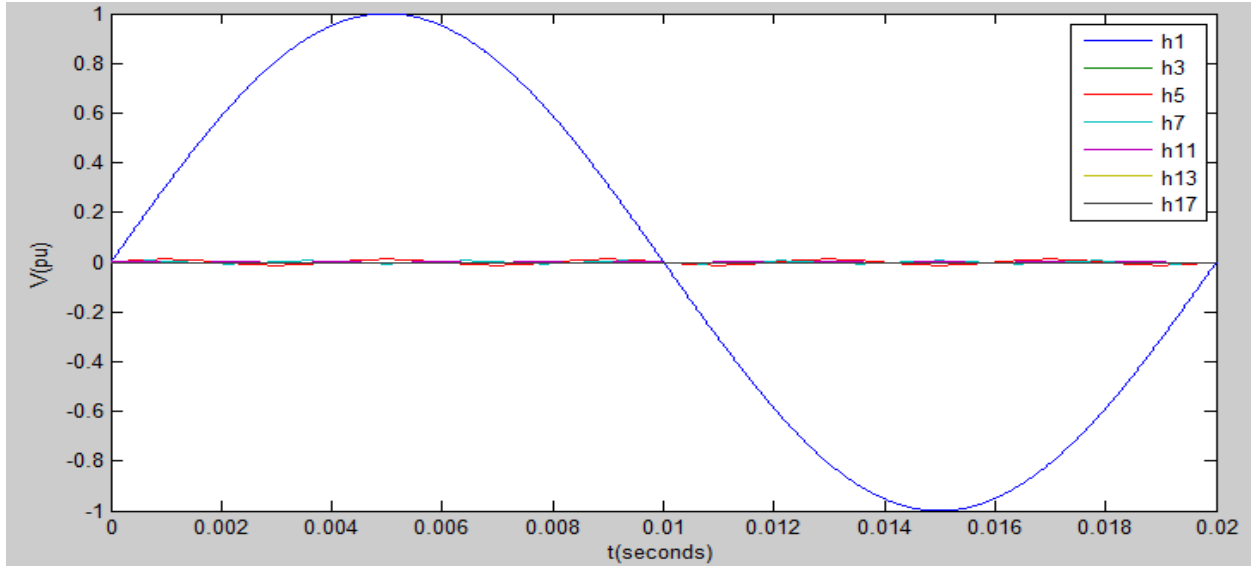

Figure 3.19: Voltage harmonic spectral components wave for transformer 3.

Figure (3.20) shows the simulated distorted current wave form on the transformer supplying pasta processing machineries. And figure (3.21) shows current spectral harmonic components on the same transformer. As it can be seen from the simulated graph, again the current harmonics are the main problems in the factory with the dominant 5th and 7th harmonics.

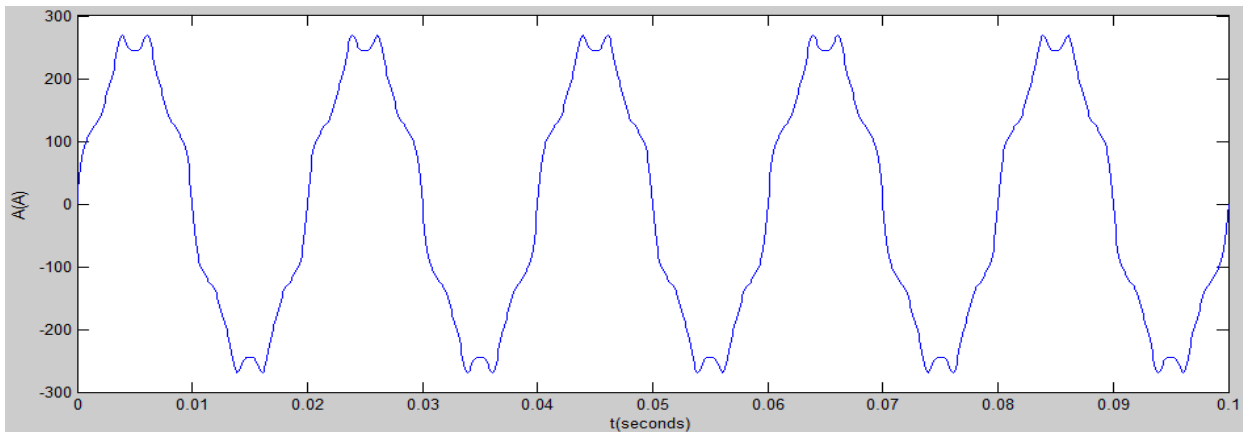

Figure 3.20: Single phase current distorted wave for transformer 3

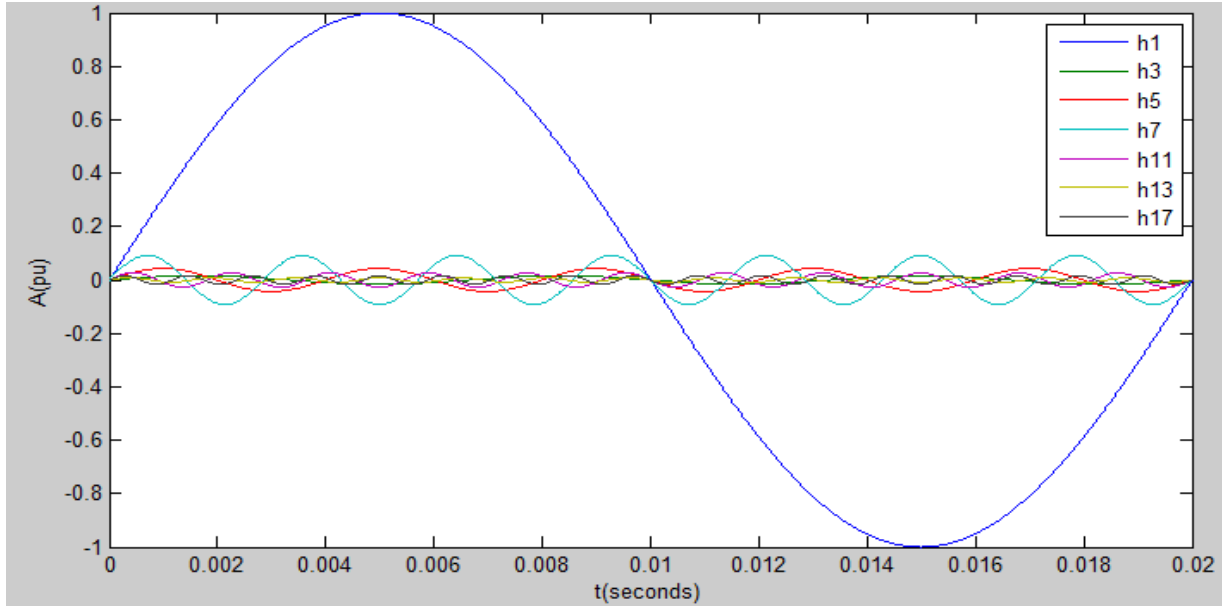

Figure 3.21: Wave forms of harmonic current spectral components for transformer 3

From Individual RMS current harmonic components on appendix [A], the dominant harmonic components are 5th (6%) and 7th (11%) harmonics. According to current harmonic standards the 5th and 7th harmonics are beyond standard. Taking transformer impedance; 0.6% from its name plate, total load demand and line to line voltage using equation (3.1), (3.2) and (3.3) to calculate the short circuit ratio, the load current is 200A and short circuit current is 2117A. The short circuit ratio becomes 10.58 which is in the first row of IEEE harmonic current distortion standard shown in table (3.1). This value shows the harmonic current distortion level is beyond the standard and should be mitigated.

Table 3.16: Average Frequency, Real power, Apparent power and Power factor data measured from transformer 3

Frequency		Average power					Average Power factor			
Hz		W1	W2	W3	W total	VA total	PF1	PF1	PF3	PF Mean
Min	Max									
59.9	50.12									
49.984		13,945	13,249	12,323	39,518	59,857	0.813	0.757	0.737	0.764

Table 3.16 shows the average real power, apparent power and power factor reading as indicated in the table. As the data taken from the transformer implies, the average power factor value is 0.764 which is low. The factory is penalized for the low power factor which is a problem for the factory. Therefore the power factor should be corrected so that the efficient use of power is ensured.

3.2.4. Summary of voltage variations

Table (3.17) shows the voltage variation measured on secondary side of the three transformers at Africa plc. These data have been summarized from figures found in Table (3.5), (3.10) and (3.13).

Table 3.17: Voltage variation from the transformers

Transformers	Nominal voltage RMS (V)	Phase No.	Minimum (V)	Maximum (V)	Average (V)
On new macaroni feeder	220	1	200	206.1	203
		2	199	205	203
		3	198.9	205.1	202
On old macaroni feeder	220	1	196.2	205	200.5
		2	196	204.9	200.6
		3	197.2	205.9	201.5
On pasta feeder	220	1	139.9	211.4	175.6
		2	140.7	212.5	176.6
		3	140.7	212.6	176.6

The summarized information contains RMS, minimum, maximum and average value of each phase on each transformer. Voltage variation standard states 10% deviation is permissible. It has been seen in figure (3.2), (3.3) and (3.4) that there are voltage variation at different occasions. The root cause of voltage variation has been faults on the utility power distribution and poor voltage regulation at the substation.

3.2.5. Summary voltage and current unbalances

The table below shows the summary of voltage and current unbalances on the whole feeders in percentage (V %) and (A %) for voltage and current respectively.

Table 3.18: Summary voltage and current unbalances for the three transformers

Transformer	Voltage unbalance V (%)	Current unbalance A (%)
New macaroni feeder	0.2%	0.75%
Old macaroni feeder	0.33%	4.37%
Pasta feeder	0.28%	2%

ANSI C84.1-1989 recommends that the maximum voltage unbalance measured at the meter under no load conditions should not exceed 3%.

For voltage imbalance greater than 1% at a Customer's motor terminals, the motor should be de-rated; ANSI Standard MG-1 provides guidelines for motor de-rating to avoid excessive motor heating. Additionally, excessive current imbalance due to supply voltage imbalance can cause nuisance tripping of motor protective devices. NEMA MG-1 states that 1% of voltage unbalance can create 6-10% current unbalance. The Customer is responsible for balancing the loads in their facility to ensure adequate levels of balance are maintained during all loading conditions. While the standards differ, motors are generally able to handle a certain amount of voltage unbalance up to 5% through derating [8]. None of the measurement taken shows condition of unbalance.

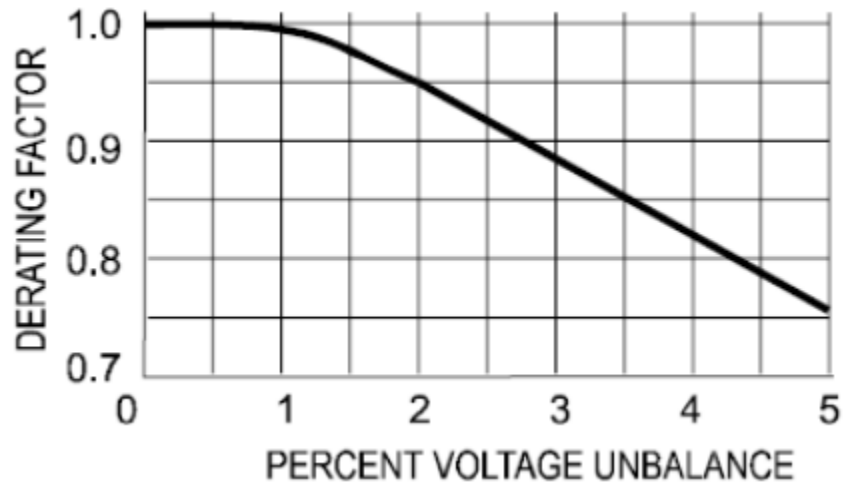

Figure 3. 22: De-rating factor for squirrel cage induction motors due to unbalanced voltage standard ANSI/NEMA MG1[8]

3.2.6. Summary of power frequency variation

Table 3.19 shows the power frequency variation measured on secondary side of the three transformers at Africa PLC. These data have been summarized from measured figure found in table (3.5), (3.12) and (3.16). The summarized information contains minimum and maximum value of frequency with maximum deviation from 50 Hz. As it can be seen from the table there is no problem of power frequency variation compared to the standard of 5% maximum deviation.

Table 3.19: Power frequency variation measured from the transformers

Transformers	Frequency		Maximum deviation(%) from 50 Hz
	Min (Hz)	Max (Hz)	
New macaroni feeder	50	50.1	0.2
Old macaroni feeder	49.8	50.1	0.4
Pasta feeder	49.9	50.12	0.24

3.3. Sources of Power Quality Problems at Africa PLC

The major power quality problems in the factory are power interruption, harmonic distortion and poor power factor. The sources of these problems should be identified to find solutions for these problems.

Causes of sustained interruption

The reliability analysis done on the distribution substation under section 3.1.1 indicates frequent sustained interruption has been a problem for the factory. According to the recorded data gathered from Adama distribution substation, the major causes of the interruptions are the following:

- Operational (maintenance, device replacement and other work on the distribution lines)
- Fault (Short circuit)
- Overload

Sources of the harmonics in the factory

Harmonics are the most serious problem among the problems identified. The sources of the harmonics are:

- Adjustable Speed Drives
- Computers
- Fluorescent lamps
- Small UPS

Most of the loads in the factory are squirrel cage induction motors. These motors are controlled by adjustable speed drive called micro master 440 to control their speed.

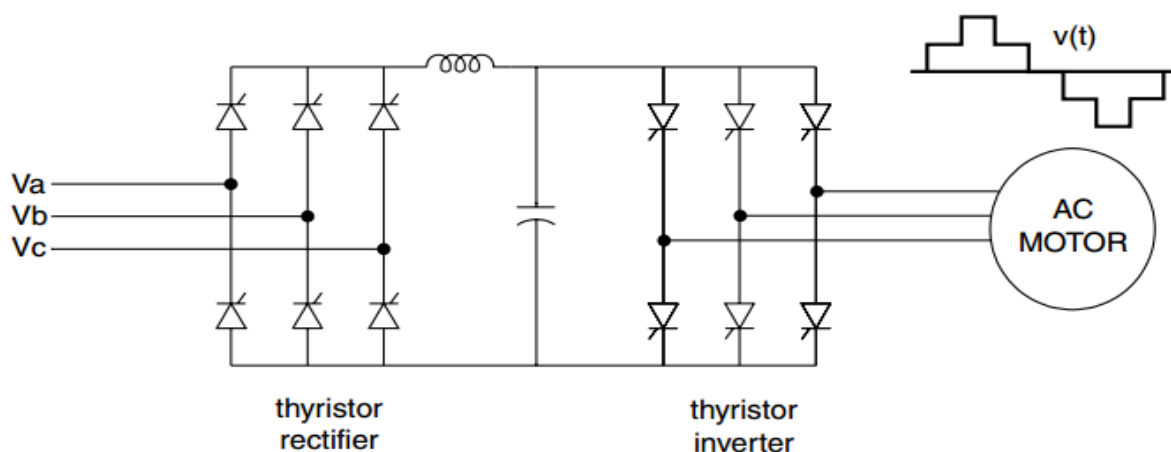

Figure 3.23: PWM ASD [17]

Variable frequency drives are representing the group of equipment that is using static converters based on a three-phase bridge. This bridge is also known as six-pulse bridge or shortly named B6-bridge. The same technology is also used in UPS units or AC/DC converters, e.g. solar inverters [17] [18]. The name B6 is derived from the six voltage pulses per cycle which result of one pulse per half cycle per phase. The harmonic current distortion in adjustable-speed drives is not constant. The waveform changes significantly for different speed and torque values. As in general the harmonic spectrum is related to the number of pulses of the non-linear load (or the paths of conduction) a B6-bridge is creating current harmonics of the orders which means 5th and 7th, 11th and 13th, 17th and 19th and so on [13], the so called pairs with one less and one more than each multiple of 6. As already mentioned, the harmonic spectrum is depending on the number of pulses, thus the harmonic spectrum will look different if a 12- or 18-pulse converter is used.

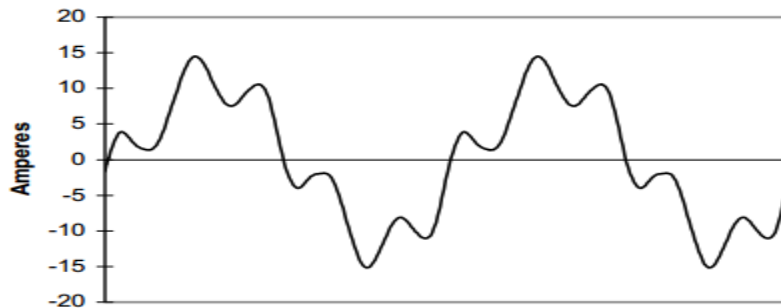

Figure 3. 24: Typical harmonic distortions from ASD [13]

3.4. Proposed Mitigation Techniques

3.4.1. Harmonics mitigation systems

There are three main techniques used to reduce or, more accurately, to control the flow of harmonic currents from nonlinear loads in industrial and commercial plants into utility power systems [8]. They are:

- Use of shunt filters
- Use of multi pulse static power converters or phase-shifting transformers

➤ Harmonic current injection.

The first one, use of shunt filters, is the best economical, technically simple and most common in industrial loads.

Design of shunt harmonic filter to reduce current harmonic distortion

The design procedure of single tuned shunt harmonic filter is:

1. Calculate the value of the capacitance needed to improve the power factor and to eliminate any penalty by the electric power company.
2. Choose a reactor to tune the series capacitor to the desired harmonic frequency
3. Calculate the peak voltage at the capacitor terminals and the RMS reactor current.
4. Choose standard components for the filter and verify filter performance to assure that capacitor components will operate within IEEE-18 recommended limits

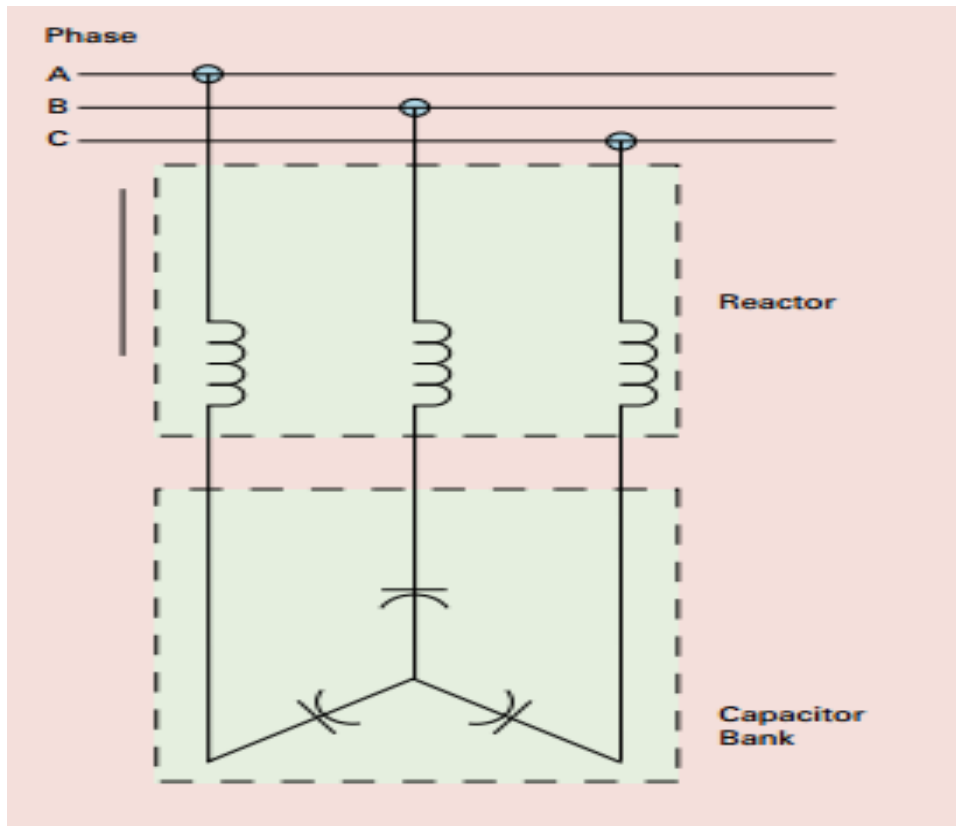

Figure 3.25: Harmonic filter and power factor correction configuration

Most harmonic flow analysis on power systems is performed using steady-state, linear circuit solution techniques. Harmonic sources, which are nonlinear elements, are generally considered to be injection current sources into the linear network models. They can be represented as current injection sources or voltage sources. For most harmonic flow studies, it is suitable to treat harmonics sources as simple sources of harmonic currents [7].

Modelling of non linear loads

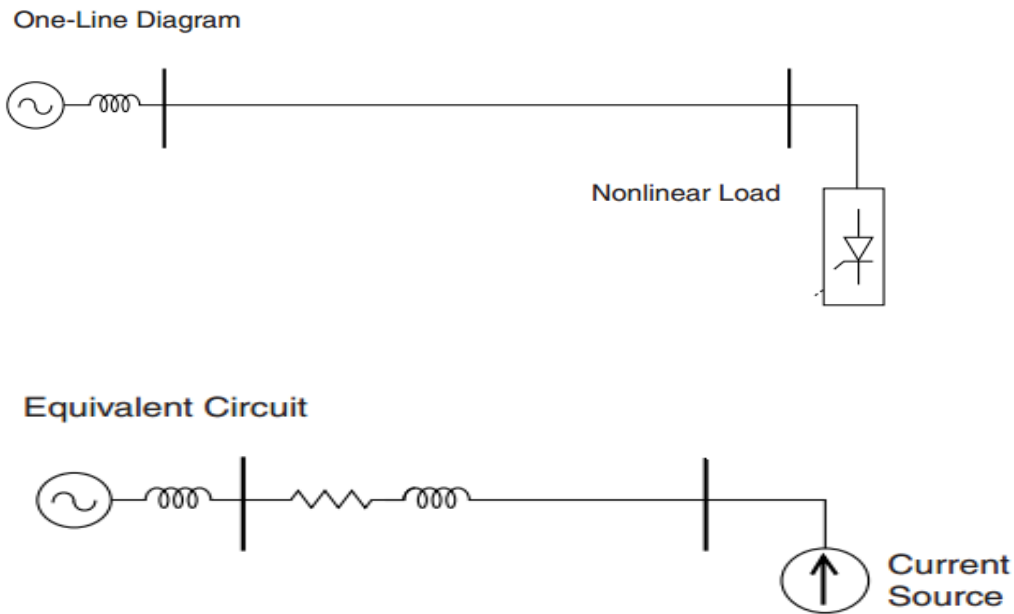

Figure 3.206: Representation of nonlinear loads as a current source for analysis [8]

3.4.2. Power factor correction

Power factor is defined as the ratio between the active component P and the total value of the apparent power S .

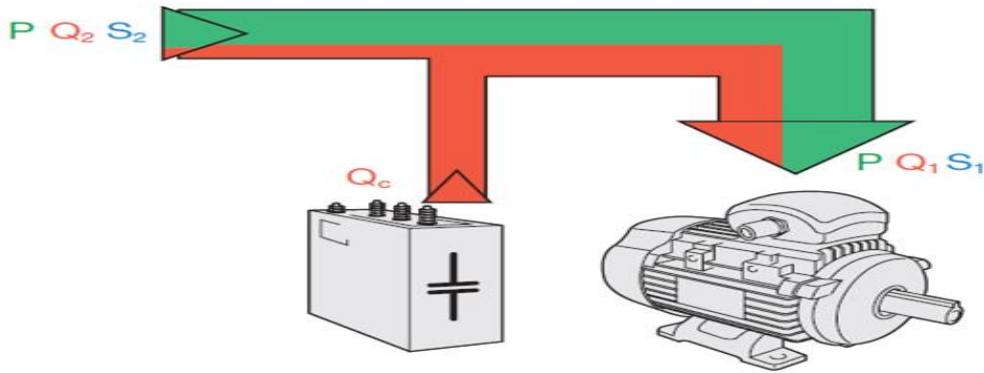
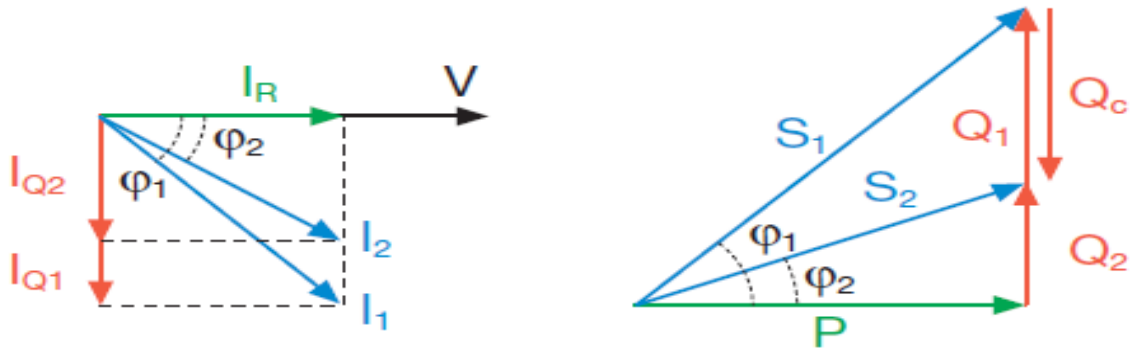

Figure 3.217: Active, reactive and apparent power diagram [19]



$$\tan(\varphi_1) = \frac{Q_1}{P} \rightarrow Q_1 = P \tan(\varphi_1)$$

$$\tan(\varphi_2) = \frac{Q_2}{P} \rightarrow Q_2 = P \tan(\varphi_2)$$

$$Q_2 = Q_1 - Q_c \rightarrow Q_c = Q_1 - Q_2$$

$$Q_c = P[\tan(\cos^{-1}(PF_1)) - \tan(\cos^{-1}(PF_2))] \quad (3.6)$$

Whereas:

P - Active power

Q_1 - Reactive power before power factor correction

φ_1 - Phase displacement angle before power factor correction

Q_2 - Reactive power after power factor correction

φ_2 - Phase displacement after power factor correction

Q_c - Reactive power for power factor correction

Q_c - Reactive power for power factor correction

Some inductive loads need much reactive power from the utility supplying electric power. But this has a limit how reactive power to be sent from the utility. The rest is to be generated near to the load requiring it. This is known as power factor improvement.

Improving the power factor means taking the necessary steps to increase the power factor in a defined section of the installation by locally delivering the necessary reactive power so that the value of the current and consequently of the power flowing through the upstream network can be reduced, at the same time required output power. In this way, the lines, the generators and the transformers can be sized for a lower apparent power. Thus, this improvement of power factor is known as power factor correction (PFC).

For what said above, the main advantages of power factor correction can be summarized as follows: For what said above, the main advantages of power factor correction can be summarized as follows:

- Better utilization of electrical machines;
- wise utilization of electrical lines;
- Reduction of losses;
- Reduction of voltage drops.

Utility companies will provide a limited amount of reactive power at no cost, however, customers with high reactive power loads are charged for the additional power. They call this additional charge a power factor penalty (or power factor surcharge PFS). The target power factor is the power factor; a consumer must obtain to avoid paying a power factor penalty. Ethiopian electric power utility set the target power factor which vary anywhere from 85% to 100%.

Voltage Rise at End User Bus

The voltage rise from placing capacitors on an inductive circuit is a two-edged sword from the power quality standpoint. If the voltage is low, then the capacitors provide an increase to bring the voltage back into tolerable limits. However, if the capacitors are left energized when the load is turned off, the voltage can rise too high, resulting in a sustained overvoltage.

The voltage rise by the end user from the installation of capacitors is approximated by the following equation [8].

$$\% \Delta V = \frac{\text{kVAR}_{\text{cap}} * Z_{T(\%)}}{\text{kVA}_T} \quad (3.7)$$

Whereas:

$\% \Delta V$ - Percentage rise in voltage

kVAR_{cap} - Capacitor bank rating

kVA_T - Step down transformer rating

$Z_{T(\%)}$ - Step down transformer impedance, %

This formula assumes that the transformer is the bulk of the total impedance of the power system up to the point at which the capacitor is applied.

CHAPTER FOUR

Simulation Studies

4.1. Introduction

African PLC takes power from medium voltage feeder which is 15 KV line. This voltage is stepped down to 380V by three transformers of each 1250kVA, 15/0.38 KV. The whole power quality data have been analyzed and are compared with different international standards in chapter three. In this chapter simulation studies with different mitigation techniques and economic analysis of these techniques are also presented.

4.2. Under Voltage

The phenomena of voltage variations do not occur periodically with the power period of the factory. The problem has been not related to full load working of the factory. Therefore we can deduce that, voltage variations at factory arise mainly from faults on the distribution system and the poor voltage regulation at the level of the substation. This thesis work does not propose solution to under voltage at the factory level since the problem originate at utility level. The solution should be at the grid level that effective voltage regulation systems should be used to avoid under voltages. Protective systems of short circuits and earth faults must also be appropriately installed to prevent voltage variations that arise from faults.

4.3. Design of Power Factor Corrector

The power data was gathered by measuring directly on terminal of the transformer on the old macaroni processing section feeder and also compared to the last twelve month record of the load. As it can be observed from the table, the average power factor of the feeder is 0.768 which is below the Ethiopian Electric Utility (EEU) standard which is 0.85. The best solution of the problem is installing capacitor bank. The average active power and apparent power of the load are 38.317 kW and 57.673 kVA respectively. The power factor should be corrected to be above 0.85. But the considered target power factor is 0.96 in this thesis work.

The additional reactive power to be generated can be calculated as follows.

Before installation of capacitor bank, $Q_1 = 38.317 \text{ kW} \cdot \tan(\cos^{-1}(0.768)) = 31.95 \text{ kVAr}$

After installation of capacitor bank, $Q_2 = 38.317 \tan(\cos^{-1}(0.96)) = 11.18 \text{ kVAr}$

Additional $Q_1 - Q_2 = 20.77 \text{ kVAr}$ should be installed. So, a capacitor bank of capacity 21 kVAr is needed to correct the power factor to 0.96.

4.4. Harmonic Distortion Mitigation

The data presented justified that harmonic distortion measured on the transformers of old Macaroni are within standards. But the harmonic distortion data on the transformer of new Macaroni and pasta machineries are beyond the standard. Data gathered from transformer of new Macaroni and Pasta sections shows 5th and 7th harmonics are significant as it can be seen from the analysis done in chapter three and also the data on the Appendix (A). So mitigation techniques should be designed for the dominant 5th and 7th harmonic components. It has been explained in chapter three that the shunt harmonic filters are both simple and economical way of mitigating harmonics.

4.4.1. Filter design and Power Factor upgrading for transformer 1

The whole filter design procedures have been discussed in chapter three. In this section the design activity is the issue to be concentrated on by considering the main steps.

Select a tuned frequency for the filter

Filtering should start at the lowest harmonic frequency generated by the load which is 5th harmonic in this case. The filter will be tuned slightly below harmonic frequency of the concern [23] (5 and 7 in this case) to allow tolerances for the filter components and variation in system impedance. This prevent the filter from acting as a direct short circuit for the offending harmonic currents, reduce duty on the filter components, and minimize the possibility of dangerous harmonic resonance should the system parameters change and cause the tuning frequency to shift. This will also overcome detuning effect of filter due to higher value of shift & allow providing low impedance path to harmonic current.

Computing capacitor bank size and the resonant frequency`

The source impedance will always have a tendency of affecting the system resonant condition[23]. This total source impedance will be so much has impact that resonant condition of system will be just before the tune frequency & operate the filter with some neighboring frequency. When there are multiple harmonic filters connected in the system, the resonant of filter circuit will affect the all harmonic filters. The filter size is based on the load reactive power requirement for the power factor correction.

The total apparent power on the feeder for new Macaroni section is 102.7kVA with the bus voltage of 380V and 0.814 power factor lagging. The dominant harmonic currents are the 5th and the 7th harmonic current as it can be seen from the analysis done in chapter three. This feeder is supplied with 1250 kVA Transformer of 6% impedance.

The filters upgrade the power factor to 0.96 in addition to filtering harmonic components. The tuned frequencies for the filters are selected to 5th and 7th harmonics. From 102.7kVA three phase capacity each phase has capacity of 34.24kVA by assuming equal sharing of the load for each phase. Adding 30% extra capacity for the design for the safety reasons each phase will have a capacity of 44.512 kVA at power factor of 0.814.

The reactive power drawn by each phase becomes:

$$Q_1 = 44.512 \text{ kVA} \sin(\cos^{-1}(0.814)) = 25.855 \text{ VAr} \quad (4.1)$$

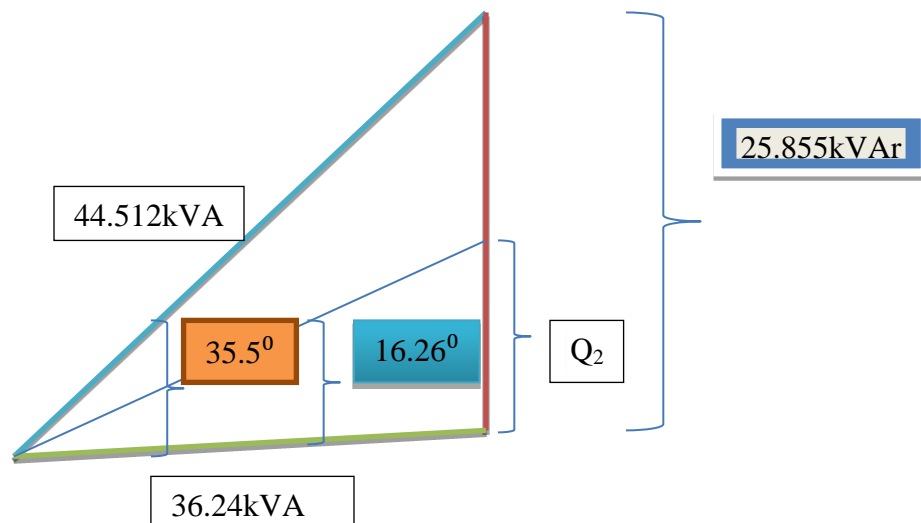

When the power factor is corrected to 0.96 the reactive power drawn from the utility becomes

$$Q_2 = 36.24\text{kW}\tan(\cos^{-1}(0.96)) = 15.285\text{kVAr} \quad (4.2)$$

The remaining 10.57 kVAr ($Q_1 - Q_2$) reactive power should be injected by filters.

To filter out the n^{th} harmonics the parameters should be calculated as in figure (4.3) below

$$X_{ch} = X_{lh} = \frac{1}{\omega C_h} = \omega L_h \quad (4.3)$$

Whereas:

X_{ch} - Capacitive reactance for the h^{th} filter

X_{lh} - Inductive reactance for the h^{th} filter

C_h - Capacitance value for the h^{th} filter

L_h - Inductance value for the h^{th} filter

The filters are required to inject 10.57 kVAr reactive powers at the fundamental frequency, neglecting other harmonics. Since the filters (5^{th} and 7^{th}) are two parallel single tuned, the capacitor corresponding to the h^{th} harmonic filter can be shared corresponding to the magnitude of the harmonic current approximately by the following equation.

$$Q_h = Q_c * \frac{I_h}{\sum_1^h I_h} \quad (4.4)$$

Whereas:

Q_n - Reactive power to be generated by the h^{th} filter

Q_c - Total reactive power needed to be generated

I_h - Magnitude of the h^{th} harmonic current

h - Harmonic number

From equation (4.4), the 5^{th} and 7^{th} harmonic share should be calculated according to equation (4.5) and (4.6).

$$Q_5 = \text{kVAr} * \frac{I_5}{I_7 + I_5} = 10.57\text{kVAr} * \frac{31.8}{31.8 + 27.9} = 6.63\text{kVAr} \quad (4.5)$$

$$Q_7 = \text{kVAr} * \frac{I_7}{I_7 + I_5} = 10.57\text{kVAr} * \frac{27.9}{31.8 + 27.9} = 4.94\text{kVAr} \quad (4.6)$$

Depending on the value above equations (4.5) and (4.6) the filters are designed as follows:

Design of fifth harmonic filter

Capacitor of 6.63kVAr reactive power is required to filter out the 5th harmonic. It should be tuned at 4.7th harmonic because of the reasons stated under filter design procedure number 1.

The net wye-equivalent filter reactance (capacitive) is determined by:

$$X_{\text{filt}} = (X_{\text{ch}} - X_{\text{lh}}) = \frac{\text{KV}^2}{\text{MVAr}} = \frac{0.38^2}{0.00663\text{MVAr}} = 21.78 \text{ Ohm} \quad (4.7)$$

$$X_{\text{Cap}} = h^2 X_L = 4.7^2 X_L \quad (4.8)$$

The desired capacitive reactance can be determined by equation (4.9)

$$X_{\text{Cap}} = \frac{h^2 X_{\text{filt}}}{h^2 - 1} = \frac{4.7^2 X_{\text{filt}}}{4.7^2 - 1} = \frac{4.7^2 * 21.78}{4.7^2 - 1} = 22.81 \text{ Ohm} \quad (4.9)$$

$$C = \frac{1}{2\pi * 50 * 22.81} = 0.0001395\text{F} \quad (4.10)$$

Computing the filter reactor size

The reactor size can be computed as in equation (4.11):

$$X_{\text{Lfund}} = \frac{X_{\text{cap}}}{h^2} = \frac{22.81}{4.7^2} = 0.986 \text{ Ohm} \quad (4.11)$$

$$L = \frac{X_{\text{Lfund}}}{2\pi * 50} = \frac{0.986 \text{ Ohm}}{2\pi * 50} = 0.0031385\text{H}$$

Quality factor of the filter (Q)

$$Q = \frac{hX_L}{R} \quad (4.12)$$

Whereas:

h is tuning harmonic

X_L is inductance of the filter

R is resistance of the inductor.

Typical value of Q for the filter that are used in industry ranges from 15 to 80 [4]

The larger the Q value the sharper the tuning of the filter. Assuming Q=50

$$R = \frac{hX_L}{Q} = 5 * \frac{0.0031385}{50} = 0.00031385 \text{ Ohm}$$

Reactance of the transformer

$$X_T = \frac{0.06 * KV^2}{MVA} = 0.007 \text{ Ohm} \quad (4.13)$$

$$L_t = \frac{0.007}{2\pi * 50} = 0.00002228H$$

Evaluation of filter duty requirements

Evaluation of filter duty requirement typically involves capacitor bank duties. IEEE -18 standards for shunt power capacitors is used as the limiting standard to evaluate these duties.

These duties are:

- Fundamental duties
- Harmonic duties and
- RMS current and peak voltage duties

Fundamental duty

In this step, the fundamental frequency operating voltage across the capacitor bank is determined as follows:

The apparent reactance of the capacitor and reactor at the fundamental frequency is

$$X_{fund} = |X_{Lfund} - X_{(cap-wye)}| = |0.986 - 21.78| = 20.794 \text{ Ohm} \quad (4.14)$$

Fundamental frequency filter current is:

$$I_{fund} = \frac{kV/\sqrt{3}}{X_{fund}} = \frac{380/\sqrt{3}}{20.794} = 10.55A \quad (4.15)$$

The fundamental frequency operation voltage across the capacitor bank is:

$$V_{(1-l)cfund} = \sqrt{3} * I_{fund} * X_c = \sqrt{3} * 10.55 * 21.78 = 398V \quad (4.16)$$

This is the nominal fundamental capacitor voltage.

Harmonic duty requirement

In this step the maximum harmonic current expected in the filter is computed. This current has two components: harmonic current produced by the non-linear load and harmonic current from the utility side.

The measured data on Appendix (A) shows the nonlinear load produces 25% fifth harmonic of the fundamental current, harmonic currents in ampere produced by the load would be as follows, equation (4.17).

$$I_h = I_h(\text{pu}) * \frac{\text{kVA}}{\sqrt{3} * \text{kV}_{\text{actual}}} = 0.25 * \frac{102.70}{\sqrt{3} * 0.38} = 39A \quad (4.17)$$

Harmonic current contributed to the filter from the source side is estimated as follows. Neglecting the utility impedances the voltage distortion on the utility system will be limited by the impedance of the service transformer and the filter only.

- Fundamental frequency impedance of the service transformer is

$$X_{Tfund} = Z_T(\%) * \frac{\text{kV}_{\text{actual}}^2}{\text{MVA}_t} = 0.06 * \frac{0.38^2}{1.25} = 0.007 \text{ Ohm} \quad (4.18)$$

The fifth harmonic impedance of the service transformer (Transformer is inductive)

$$X_{T(\text{harm})} = h * X_{T(\text{fund})} = 5 * 0.007 = 0.035 \text{ Ohm}$$

- Harmonic impedance of the capacitor bank is

$$X_{(\text{cap-wye})_{\text{harm}}} = \frac{X_{(\text{cap-wye})}}{h} = \frac{21.78}{5} = 4.356 \text{ Ohm} \quad (4.19)$$

- Harmonic impedance of the reactor using equation (4.11):

$$X_{L(\text{harm})} = 5 * X_{Lfund} = 5 * 0.986 = 4.93 \quad (4.20)$$

Utilities are expected to supply pure sine wave voltage. But this cannot be expected because of solid state protective devices and energization of transformers involved in the power system. Assuming the voltage distortion on the utility system 1%, the estimated amount of the fifth harmonic current contributed to the filter from the source side would be:

$$I_{h(\text{utility})} = \frac{V_h \text{ utility} * KV_{\text{actual}}}{\sqrt{3} * (X_{T(\text{harm})} + X_{L(\text{harm})} - X_{(\text{cap-wye})_{\text{harm}}})} \quad (4.21)$$

$$= \frac{0.01 * 380}{\sqrt{3} * (0.035 + 4.93 - 4.356)} = 3.6A$$

The sum of the harmonic current produced by the load and that contributed from the utility side will be:

$$I_{h \text{ total}} = I_5 = 39A + 3.6A = 42.6A$$

The harmonic voltage across the capacitor can be computed as follows:

$$V_{\text{cap(L-L rms)harm}} = \sqrt{3} * I_{h \text{ total}} * \frac{X_{(\text{cap-wye})}}{h} = \frac{\sqrt{3} * 42.6 * 4.356}{5} = 64V \quad (4.22)$$

Evaluation of total RMS current and peak voltage requirement

- Total current passing through the filter

$$I_{\text{rms total}} = \sqrt{I_{\text{fund}}^2 + I_h^2} = \sqrt{10.55^2 + 42.6^2} = 43.89A \quad (4.23)$$

This is the total RMS current rating required for the filter reactor.

- Assuming the harmonic and fundamental components add together, the maximum peak voltage cross the capacitor is

$$V_{(1-l)\text{cap,peak}} = V_{(1-l)\text{cfund}} + V_{\text{cap(L-L rms)harm}} = 398V + 64V = 462V \quad (4.24)$$

- RMS voltage across the capacitor is

$$V_{\text{cap(L-L rms)total}} = \sqrt{V_{(1-l)\text{cfund}}^2 + V_{\text{cap(L-L rms)harm}}^2} = \sqrt{398^2 + 64^2} = 403V \quad (4.25)$$

The total kVAr seen by the capacitor is:

$$kVAr_{cap(wye)total} = \sqrt{3} * I_{rms\ total} * V_{cap(L-L\ rms)total} = \sqrt{3} * 43.89A * 403V = 30.64kVAr$$

This is value required for compensation of 19.89kVAr total three phase

Evaluation of capacitor rating limits

IEEE Standard for Shunt Power Capacitors (IEEE 18-1992) specifies the following continuous capacitor ratings: Table 4.1 contains the comparison of the shunt capacitor to the limits.

Table 4.1: Comparison of capacitor performance to IEEE-18 recommended limits for 5th harmonic filter on transformer 1.

Duty	Definition	Limit (%)	Actual value	Actual value (%)
Peak voltage	$\frac{V_{l-lcap(max,peak)}}{V_{rated}}$	120	$\frac{458}{400}$	115
RMS voltage	$\frac{V_{l-lcap(RMS,total)}}{V_{rated}}$	110	$\frac{402}{400}$	100
RMS current	$\frac{I_{RMS,total}}{I_{cap(rated)}}$	180	$\frac{41.4}{28.9}$	140
kVAr	$\frac{kVAr_{CAP(wye,total)}}{kVAr_{rated}}$	135	$\frac{30.64kVAr}{20kVAr}$	153

Evaluate filter frequency response.

The filter frequency response is now evaluated to make sure that the filter does not create a new resonance at a frequency that could cause additional problems. The harmonic at which the parallel resonance below the notch frequency will occur is computed as follows. This assumes the service transformer reactance dominates the source impedance (line impedance and transformer impedance) [8].

$$h_o = \sqrt{\frac{X_{cap}}{X_T + X_{L\ fund}}} \quad (4.26)$$

Whereas:

h_o - Harmonic order at resonant frequency

- $X_{L\text{fund}}$ - Inductive reactance of the filter at fundamental frequency
- X_{cap} - Capacitive reactance of the filter
- X_T - Reactance of the stepdown transformer

Substituting the values of the variables in equation (4.26) from calculated values of each parameter;

$$\sqrt{\frac{22.81}{0.007+0.986}} = 4.8$$

4.7th harmonic is slightly less than fifth harmonic and the severity of parallel resonance would be less compared to if it would be at 5th harmonic.

Design of Seventh Harmonic Filter:

Capacitor of 4.94 kVAr reactive powers is required to filter out the 7th harmonic. Again It should be tuned at 6.7th harmonic because of the reasons stated under filter design procedure number 1.

$$X_{\text{filt}} = \frac{0.38^2}{0.00494\text{MVA}_r} = 29.23 \text{ Ohm} \quad (4.27)$$

$$X_{\text{Cap}} = 6.7^2 X_L \quad (4.28)$$

The desired capacitive reactance can be determined by:

$$X_{\text{Cap}} = \frac{h^2 X_{\text{filt}}}{h^2 - 1} = \frac{6.7^2 X_{\text{filt}}}{6.7^2 - 1} = \frac{6.7^2 * 29.23}{6.7^2 - 1} = 29.9 \text{ Ohm} \quad (4.29)$$

$$C = \frac{1}{2\pi * 50 * 29.9} = 0.0001065\text{F}$$

Using equation (4.11) the reactor size can be computed as:

$$X_{L\text{fund}} = \frac{X_{\text{cap}}}{6.7^2} = \frac{29.9}{6.7^2} = 0.666 \text{ Ohm}$$

Then the inductor of the filter will be,

$$L = \frac{X_{L\text{fund}}}{2\pi * 50} = \frac{0.666 \text{ Ohm}}{2\pi * 50} = 0.0021202\text{H} \quad (4.30)$$

Quality factor of the filter (Q), using equation (4.12):

$$R = \frac{hX_L}{Q} = 7 * \frac{0.0021202}{50} = 0.00029680 \text{ Ohm} \quad (4.31)$$

Reactance of the transformer is already calculated.

Evaluation of filter duty requirements

Fundamental duty

In this step, the fundamental frequency operating voltage across the capacitor bank is determined as follows:

The apparent reactance of the capacitor and reactor at the fundamental frequency is

$$X_{\text{fund}} = |X_{L\text{fund}} - X_{(\text{cap-wye})}| = |0.666 - 29.9| = 29.234 \text{ Ohm} \quad (4.32)$$

Fundamental frequency filter current is:

$$I_{\text{fund}} = \frac{KV/\sqrt{3}}{X_{\text{fund}}} = \frac{380/\sqrt{3}}{29.234} = 7.5 \text{ A} \quad (4.33)$$

The fundamental frequency operation voltage across the capacitor bank is:

$$V_{(1-l)\text{cfund}} = \sqrt{3} * I_{\text{fund}} * X_c = \sqrt{3} * 7.5 * 29.9 = 388 \text{ V} \quad (4.34)$$

Harmonic duty requirement

In this step the maximum harmonic current expected in the filter is computed. This current has two components: harmonic current produced by the non-linear load and harmonic current from the utility side.

The measured data shows the nonlinear load produces 22% seventh harmonic of the fundamental current, harmonic currents in ampere produced by the load will be:

$$I_7 = I_7(\text{pu}) * \frac{\text{kVA}}{\sqrt{3} * \text{kV}_{\text{actual}}} = 0.22 * \frac{102.709}{\sqrt{3} * 0.38} = 31 \text{ A} \quad (4.35)$$

Harmonic current contributed to the filter from the source side is estimated as follows. Neglecting the utility impedances the voltage distortion on the utility system will be limited by the impedance of the service transformer and the filter.

- Fundamental frequency impedance of the service transformer is

$$X_{T\text{fund}} = Z_T(\%) * \frac{KV^2_{\text{actual}}}{MVA_t} = 0.06 * \frac{0.38^2}{1.25} = 0.007 \text{ Ohm}$$

The seventh harmonic impedance of the service transformer (Transformer is inductive) is:

$$X_{T(\text{harm})} = h * X_{T(\text{harm})} = 7 * 0.007 = 0.049 \text{ Ohm} \quad (4.36)$$

- Harmonic impedance of the capacitor bank is:

$$X_{(\text{cap-wye})_{\text{harm}}} = \frac{X_{(\text{cap-wye})}}{h} = \frac{29.9}{7} = 4.27 \text{ Ohm} \quad (4.37)$$

- Harmonic impedance of the reactor is:

$$X_{L(\text{harm})} = 7 * X_{L(\text{fund})} = 7 * 0.666 = 4.662 \text{ Ohm} \quad (4.38)$$

Assuming the voltage distortion on the utility system 1% as described previously, the estimated amount of the seventh harmonic current contributed to the filter from the source can be calculated by using the result of equations (4.36), (4.37) and (4.38)

$$I_{7(\text{utility})} = \frac{V_h \text{ utility \%} * KV_{\text{actual}}}{\sqrt{3} * (X_{T(\text{harm})} + X_{L(\text{harm})} - X_{(\text{cap-wye})_{\text{harm}}})} \quad (4.39)$$

$$= \frac{0.01 * 380}{\sqrt{3} * (0.049 + 4.662 - 4.27)} = 5A$$

The maximum the sum of the harmonic current produced by the load and that contributed from the utility from equation (4.29) and (4.33) respectively:

$$:I_{7\text{total}} = 31A + 5A = 36A$$

The harmonic voltage across the capacitor can be computed as follows:

$$V_{\text{cap}(L-L \text{ rms})_{\text{harm}}} = \sqrt{3} * I_{h \text{ total}} * \frac{X_{(\text{cap-wye})}}{h} = \frac{\sqrt{3} * 36 * 4.27}{7} = 38V \quad (4.40)$$

Evaluate total RMS current and peak voltage requirement

- Total current passing through the filter

$$I_{\text{rms total}} = \sqrt{I_{\text{fund}}^2 + I_h^2} = \sqrt{36^2 + 5^2} = 36A \quad (4.41)$$

This is the total RMS current rating required for the filter reactor.

- Assuming the harmonic and fundamental components add together, the maximum peak voltage cross the capacitor is

$$V_{(l-l)\text{cap,peak}} = V_{(l-l)\text{cfund}} + V_{\text{cap}(L-L \text{ rms})_{\text{harm}}} = 388V + 38V = 426V \quad (4.42)$$

- RMS voltage across the capacitor is

$$V_{\text{cap(L-L rms)total}} = \sqrt{V_{(1-l)cfund}^2 + V_{\text{cap(L-L rms)harm}}^2} = \sqrt{388^2 + 38^2} = 390V$$

The total kVAR seen by the capacitor is:

$$\text{kVAR}_{\text{cap(wye)total}} = \sqrt{3} * I_{\text{rms total}} * V_{\text{cap(L-L rms)total}} = \sqrt{3} * 36A * 390V = 24.317\text{kVAR}$$

Evaluation of capacitor rating limits

IEEE Standard for Shunt Power Capacitors (IEEE 18-1992) specifies the following continuous capacitor ratings and the calculated value is compared to it. Table 4.2 contains the comparison of the shunt capacitor to the limits.

Table 4.2: Comparison of capacitor performance to IEEE-18 recommended limits for 7th harmonic filter on transformer 1.

Duty	Definition	Limit (%)	Actual value	Actual value (%)
Peak voltage	$\frac{V_{1-l\text{cap(max,peak)}}}{V_{\text{rated}}}$	120	$\frac{426}{400}$	107
RMS voltage	$\frac{V_{1-l\text{cap(RMS,total)}}}{V_{\text{rated}}}$	110	$\frac{390}{400}$	100
RMS current	$\frac{I_{\text{RMS,total}}}{I_{\text{cap(rated)}}}$	180	$\frac{31}{21.7}$	140
kVAr	$\frac{\text{kVAr}_{\text{CAP(wye,total)}}}{\text{kVAr}_{\text{rated}}}$	135	$\frac{24.317\text{kVAr}}{15\text{kVAr}}$	160

Computing Filter frequency response

Substituting the values of the variables in equation (4.26) from calculated values of each parameter;

$$\sqrt{\frac{29.9}{0.007+0.666}} = 6.7$$

6.7th harmonic is slightly less than seventh harmonic and the severity of parallel resonance would be less compared to if it would be at 7th harmonic.

4.4.2. Filter design and power factor upgrading for transformer supplying pasta processing machineries

From the total 59.857 kVA three phase capacity, each phase has a capacity of 19.952kVA by assuming equal sharing of the load for each phase. Adding 30% extra capacity for the safety reasons each phase will have a capacity of 25.937 kVA at power factor of 0.764. The target power factor is 0.96.

The reactive power drawn by each phase becomes:

$$Q_1 = 25.937 \text{ kVA} \sin(\cos^{-1}(0.764)) = 16.735 \text{ kVAr} \quad (4.41)$$

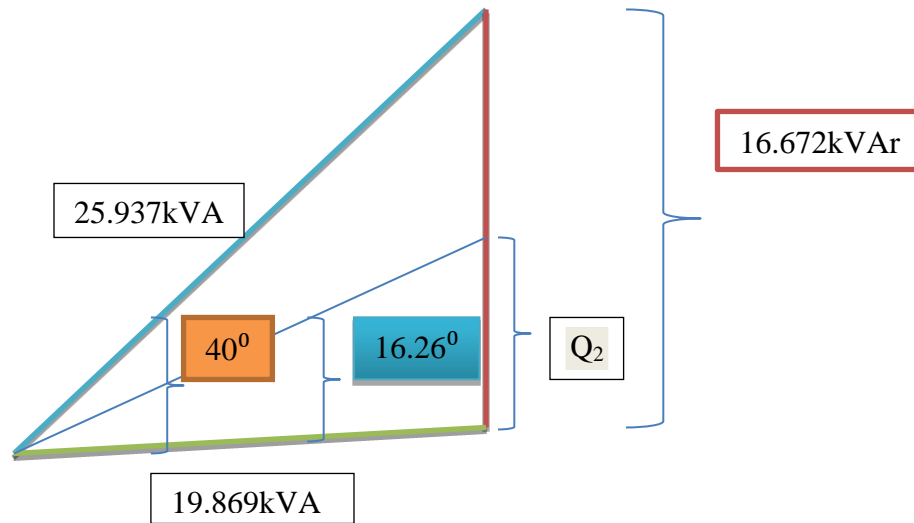

When the power factor is corrected to 0.96 the reactive power drawn from the utility becomes

$$Q_2 = 19.869 \text{ KW} \tan(\cos^{-1}(0.96)) = 5.795 \text{ kVAr} \quad (4.42)$$

The remaining 10.877 kVAr ($Q_1 - Q_2$) reactive power should be injected by filters.

To filter out the h^{th} harmonics;

$$X_{ch} = X_{lh} = \frac{1}{\omega C_h} = \omega L_h \quad (4.43)$$

10.877 kVAr reactive powers required to be injected at the fundamental frequency. Since the filter is two parallel single tuned, the capacitor corresponding to the n^{th} harmonic filter can be distributed approximately by the following equation. The dominant harmonic components are 5^{th} (6%) and the 7^{th} (11%) of the load current.

$$Q_{fh} = Q_c * \frac{I_h}{\sum I_h} \quad (4.44)$$

From this, the 5^{th} and 7^{th} harmonic share should be calculated as follows.

$$Q_{f5} = \text{kVAr} * \frac{I_5}{I_5 + I_7} = 10.877 \text{kVAr} * \frac{10.5}{19 + 10.5} = 3.9 \text{kVAr} \quad (4.45)$$

$$Q_{f7} = \text{kVAr} * \frac{I_7}{I_5 + I_7} = 10.877 \text{kVAr} * \frac{19}{19 + 10.5} = 7 \text{kVAr} \quad (4.46)$$

Depending on the value above equations (4.45) and (4.46) the filters are designed as follows:

Design of fifth harmonic filter

Capacitor of 3.9kVAr reactive power is required to filter out the 5^{th} harmonic. It should be tuned at 4.7^{th} harmonic because of the reasons stated under filter design procedure number 1.

$$X_{\text{filt}} = (X_{\text{ch}} - X_{\text{lh}}) = \frac{\text{KV}^2}{\text{MVAR}} = \frac{0.38^2}{0.0039 \text{MVAR}} = 37 \text{ Ohm}$$

The capacitive reactance $X_{\text{cap}} = h^2 X_L$ and tuning at 4.7^{th} harmonic

$$X_{\text{Cap}} = 4.7^2 X_L \quad (4.47)$$

The desired capacitive reactance can be determined by:

$$X_{\text{Cap}} = \frac{h^2 X_{\text{filt}}}{h^2 - 1} = \frac{4.7^2 X_{\text{filt}}}{4.7^2 - 1} = \frac{4.7^2 * 37}{4.7^2 - 1} = 38.75 \text{ Ohm} \quad (4.48)$$

$$C = \frac{1}{2\pi * 50 * 38.75} = 0.000082 \text{F} \quad (4.49)$$

Computing the filter reactor size:

Using equation (4.38) the reactor size can be computed as follows.

$$X_{L\text{fund}} = \frac{X_{\text{cap}}}{h^2} = \frac{38.75}{4.7^2} = 1.75 \text{ Ohm} \quad (4.50)$$

$$L = \frac{X_{Lfund}}{2\pi * 50} = \frac{1.67 \text{ Ohm}}{2\pi * 50} = 0.00558H \quad (4.51)$$

Quality factor of the filter (Q), using equation (4.12):

$$R = \frac{hX_L}{Q} = 5 * \frac{0.00558}{50} = 0.0005580 \text{ Ohm} \quad (4.52)$$

Reactance of the transformer

$$X_T = \frac{0.06 * KV^2}{MVA} = 0.007 \text{ Ohm} \quad (4.53)$$

$$L = \frac{X_T}{2\pi * 50} = \frac{0.007 \text{ Ohm}}{2\pi * 50} = 0.00002228H$$

Evaluation of filter duty requirements

Evaluation of filter duty requirement typically involves capacitor bank duties. IEEE standard 18-1992 for shunt power capacitors is used as the limiting standard to evaluate these duties. These duties are:

- Fundamental duties
- Harmonic duties and
- RMS current and peak voltage duties

Fundamental duty

In this step, the fundamental frequency operating voltage across the capacitor bank is determined as follows:

The apparent reactance of the capacitor and reactor at the fundamental frequency is

$$X_{fund} = |X_{Lfund} - X_{(cap-wye)}| = |1.75 - 38.50| = 36.75\text{Ohm} \quad (4.54)$$

Fundamental frequency filter current is

$$I_{fund} = \frac{KV/\sqrt{3}}{X_{fund}} = \frac{380/\sqrt{3}}{36.75} = 6A \quad (4.55)$$

The fundamental frequency operating voltage across the capacitor bank is:

$$V_{(l-l)c fund} = \sqrt{3} * I_{fund} * X_c = \sqrt{3} * 6 * 38.5 = 400V \quad (4.56)$$

This is the nominal fundamental capacitor voltage.

Harmonic duty requirement

In this step the maximum harmonic current expected in the filter is computed. This current has two components: harmonic current produced by the non-linear load and harmonic current from the utility side.

The measured data on Appendix (A) shows the nonlinear load produces 6% fifth harmonic of the fundamental current, harmonic currents in ampere produced by the load would be as follows, equation (4.57).

$$I_h = I_h(\text{pu}) * \frac{\text{kVA}}{\sqrt{3} * \text{kV}_{\text{actual}}} = 0.06 * \frac{59.857}{\sqrt{3} * 0.38} = 6\text{A} \quad (4.57)$$

Harmonic current contributed to the filter from the source side is estimated as follows. Neglecting the utility impedances the voltage distortion on the utility system will be limited by only the impedance the service transformer and the filter.

- Fundamental frequency impedance of the service transformer is:

$$X_{T\text{fund}} = Z_T(\%) * \frac{\text{KV}^2_{\text{actual}}}{\text{MVA}_t} = 0.06 * \frac{0.38^2}{1.25} = 0.007 \text{ Ohm}$$

The fifth harmonic impedance of the service transformer (Transformer is inductive)

$$X_{T(\text{harm})} = h * X_{T(\text{fund})} = 5 * 0.007 = 0.035 \text{ Ohm}$$

- Harmonic impedance of the capacitor bank is

$$X_{(\text{cap-wye})_{\text{harm}}} = \frac{X_{(\text{cap-wye})}}{h} = \frac{38.75}{5} = 7.75 \text{ Ohm} \quad (4.58)$$

- Harmonic impedance of the reactor is

$$X_{L(\text{harm})} = 5 * X_{L\text{fund}} = 5 * 1.75 = 8.75\text{Ohm} \quad (4.59)$$

Assuming the voltage distortion on the utility system 1%, the estimated amount of the fifth harmonic current contributed to the filter from the source side would be:

$$I_{h(\text{utility})} = \frac{V_h * \text{KV}}{\sqrt{3} * (X_{T(\text{harm})} + X_{L(\text{harm})} - X_{(\text{cap-wye})_{\text{harm}}})}$$

$$= \frac{0.01 * 380}{\sqrt{3} * (0.035 + 8.75 - 7.75)} = 2\text{A} \quad (4.60)$$

The maximum the sum of the fifth harmonic current produced by the load and that contributed from the utility side will be:

$$I_{h \text{ total}} = I_5 = 6A + 2A = 8A$$

The harmonic voltage across the capacitor can be computed as follows:

$$V_{\text{cap(L-L rms)harm}} = \sqrt{3} * I_{h \text{ total}} * \frac{X_{(\text{cap-wye})}}{h} = \frac{\sqrt{3} * 8 * 7.75}{5} = 21V \quad (4.61)$$

Evaluation of total RMS current and peak voltage requirement

- Total current passing through the filter

$$I_{\text{rms total}} = \sqrt{I_{\text{fund}}^2 + I_h^2} = \sqrt{9.97^2 + 8^2} = 12.8A$$

This is the nominal current rating required for the filter reactor.

- Assuming the harmonic and fundamental components add together, the maximum peak voltage cross the capacitor is

$$V_{(1-l)c,\text{peak}} = V_{(1-l)c,\text{fund}} + V_{\text{cap(L-L rms)harm}} = 400V + 21V = 421V \quad (4.62)$$

- RMS voltage across the capacitor is

$$V_{\text{cap(L-L rms)total}} = \sqrt{V_{(1-l)c,\text{fund}}^2 + V_{\text{cap(L-L rms)harm}}^2} = \sqrt{400^2 + 21^2} = 400V$$

The total kVAr seen by the capacitor is

$$\text{kVAr}_{\text{cap(wye)total}} = \sqrt{3} * I_{\text{rms total}} * V_{\text{cap(L-L rms)total}} = \sqrt{3} * 12.8A * 400V = 8.70\text{kVAr}$$

Evaluation of capacitor rating limits

IEEE Standard for Shunt Power Capacitors (IEEE 18-1992) specifies the following continuous capacitor ratings and the calculated value is compared to it. Table 4.3 contains the comparison of the shunt capacitor to the limits.

Table 4.3: Comparison of capacitor performance to IEEE-18 recommended limits for 5th harmonic filter on transformer 3.

Duty	Definition	Limit (%)	Actual value	Actual value (%)
Peak voltage	$\frac{V_{1-lcap(max,peak)}}{V_{rated}}$	120	$\frac{421}{400}$	105
RMS voltage	$\frac{V_{1-lcap(RMS,total)}}{V_{rated}}$	110	$\frac{400}{400}$	100
RMS current	$\frac{I_{RMS,total}}{I_{cap(rated)}}$	180	$\frac{10}{7.2}$	140
kVAr	$\frac{kVAr_{CAP(wye,total)}}{kVAr_{rated}}$	135	$\frac{8.70kVAr}{5kVAr}$	160

Computing Filter frequency response

Substituting the values of the variables in equation (4.26) from calculated values of each parameter;

$$\sqrt{\frac{38.75}{0.007+1.75}} = 4.7$$

4.7th harmonic is slightly less than fifth harmonic and the severity of parallel resonance would be less compared to if it would be at 5th harmonic.

Design of the Seventh harmonic filter

Capacitor of 7KVAR reactive power is required to filter out the 7th harmonic. It should be tuned at 6.7th harmonic because of the reasons stated under filter design procedure number 1.

$$X_{filt} = (X_{ch} - X_{lh}) = \frac{KV^2}{MVAR} = \frac{0.38^2}{0.007MVAR} = 20.630\Omega \quad (4.63)$$

The capacitive reactance $X_{cap} = h^2 X_L$ and tuning at 6.7th harmonic

$$X_{Cap} = 6.7^2 X_L \quad (4.64)$$

The desired capacitive reactance can be determined by:

$$X_{Cap} = \frac{h^2 X_{filt}}{h^2 - 1} = \frac{6.7^2 X_{filt}}{6.7^2 - 1} = \frac{6.7^2 * 20.63}{6.7^2 - 1} = 21.10\Omega \quad (4.65)$$

$$C = \frac{1}{2\pi * 50 * 21.1} = 0.00015F$$

Computing the filter reactor size

The reactor size can be computed as follows:

$$X_{Lfund} = \frac{X_{cap}}{h^2} = \frac{21.1}{6.7^2} = 0.47 \text{ Ohm} \quad (4.66)$$

$$L = \frac{X_{Lfund}}{2\pi * 50} = \frac{0.47 \text{ Ohm}}{2\pi * 50} = 0.001496H \quad (4.67)$$

Quality factor of the filter (Q), using equation (4.12):

$$R = \frac{hX_L}{Q} = 7 * \frac{0.001496}{50} = 0.00020944 \text{ Ohm}$$

Reactance of the transformer calculated already:

$$X_T = \frac{0.06 * KV^2}{MVA} = 0.007 \text{ Ohm}$$

$$L = \frac{X_T}{2\pi * 50} = \frac{0.007 \text{ Ohm}}{2\pi * 50} = 0.00002228 \text{ H}$$

Evaluation of filter duty requirements

Evaluation of filter duty requirement typically involves capacitor bank duties. IEEE standard 18-IEEE for shunt power capacitors is used as the limiting standard to evaluate these duties. These duties are:

- Fundamental duties
- Harmonic duties and
- RMS current and peak voltage duties

Fundamental duty

In this step, the fundamental frequency operating voltage across the capacitor bank is determined as follows:

The apparent reactance of the capacitor and reactor at the fundamental frequency is:

$$X_{fund} = |X_{Lfund} - X_{(cap-wye)}| = |0.47 - 21.1| = 20.630\text{ohm} \quad (4.68)$$

Fundamental frequency filter current is

$$I_{\text{fund}} = \frac{KV/\sqrt{3}}{X_{\text{fund}}} = \frac{380/\sqrt{3}}{20.63} = 10.63A \quad (4.69)$$

The fundamental frequency operation voltage across the capacitor bank is:

$$V_{(l-1)\text{cfund}} = \sqrt{3} * I_{\text{fund}} * X_c = \sqrt{3} * 10.63 * 21.1 = 388V \quad (4.70)$$

Harmonic duty requirement

In this step the maximum harmonic current expected in the filter is computed. This current has two components: harmonic current produced by the non-linear load and harmonic current from the utility side.

The measured data on Appendix (A) shows the nonlinear load produces 11% fifth harmonic of the fundamental current, harmonic currents in ampere produced by the load would be as follows, equation

$$I_h = I_h(\text{pu}) * \frac{\text{kVA}}{\sqrt{3} * \text{kv}_{\text{actual}}} = 0.11 * \frac{59.857}{\sqrt{3} * 0.38} = 10A \quad (4.71)$$

Harmonic current contributed to the filter from the source side is estimated as follows. Neglecting the utility impedances the voltage distortion on the utility system will be limited by only the impedance the service transformer and the filter.

- Fundamental frequency impedance of the service transformer is:

$$X_{T\text{fund}} = Z_T(\%) * \frac{KV^2_{\text{actual}}}{MVA_t} = 0.06 * \frac{0.38^2}{1.25} = 0.007 \text{ Ohm} \quad (4.72)$$

The seventh harmonic impedance of the service transformer (Transformer is inductive)

$$X_{T(\text{harm})} = h * X_{T(\text{fund})} = 7 * 0.007 = 0.049 \text{ Ohm} \quad (4.73)$$

- Harmonic impedance of the capacitor bank is:

$$X_{(\text{cap-wye})_{\text{harm}}} = \frac{X_{(\text{cap-wye})}}{h} = \frac{21.1}{7} = 3.0 \text{ Ohm} \quad (4.74)$$

- Harmonic impedance of the reactor is

$$X_{L(\text{harm})} = 7 * X_{L\text{fund}} = 7 * 0.47 = 3.29 \text{ Ohm} \quad (4.75)$$

Assuming the voltage distortion on the utility system 1%, the estimated amount of the seventh harmonic current contributed to the filter from the source side would be:

$$I_{h(\text{utility})} = \frac{V_h * KV_{\text{actual}}}{\sqrt{3} * (X_{T(\text{harm})} + X_{L(\text{harm})} - X_{(\text{cap-wye})_{\text{harm}}})} \quad (4.76)$$

$$= \frac{0.01 * 380}{\sqrt{3} * (0.049 + 3.29 - 3)} = 6.9A$$

The maximum sum of the harmonic current produced by the load and that contributed from the utility side will be:

$$I_{h \text{ total}} = I_7 = 10A + 6.9A = 16.9A$$

The harmonic voltage across the capacitor can be computed as follows:

$$V_{\text{cap(L-L rms)harm}} = \sqrt{3} * I_{h \text{ total}} * \frac{X_{(\text{cap-wye})}}{h} * \frac{\sqrt{3} * 16.9 * 21.1}{7} = 88V \quad (4.77)$$

Evaluation of total RMS current and peak voltage requirement

- Total current passing through the filter will be:

$$I_{\text{rms total}} = \sqrt{I_{\text{fund}}^2 + I_h^2} = \sqrt{16.9^2 + 10.63^2} = 20A \quad (4.78)$$

- Assuming the harmonic and fundamental components add together, the maximum peak voltage across the capacitor is

$$V_{(1-l)c,\text{peak}} = V_{(1-l)c,\text{fund}} + V_{\text{cap(L-L rms)harm}} = 388V + 88V = 476V \quad (4.79)$$

- RMS voltage across the capacitor is

$$V_{\text{cap(L-L rms)total}} = \sqrt{V_{(1-l)c,\text{fund}}^2 + V_{\text{cap(L-L rms)harm}}^2} = \sqrt{388^2 + 88^2} = 398V$$

The total kVAr seen by the capacitor is:

$$\text{kVAr}_{\text{cap(wye)total}} = \sqrt{3} * I_{\text{rms total}} * V_{\text{cap(L-L rms)total}} = \sqrt{3} * 20A * 398V = 13.787\text{kVAr}$$

Evaluation of capacitor rating limits

IEEE 18-1992 standard for shunt power capacitors is used as the limiting standard to evaluate these duties. The comparison between the calculated value and the standard is made below, table (4.4).

Table 4.4: Comparison of capacitor performance to IEEE-18 recommended limits for 7th harmonic filter on transformer 3.

Duty	Definition	Limit (%)	Actual value	Actual value (%)
Peak voltage	$\frac{V_{l-cap(max,peak)}}{V_{rated}}$	120	$\frac{476}{400}$	119
RMS voltage	$\frac{V_{l-cap(RMS,total)}}{V_{rated}}$	110	$\frac{398}{400}$	100
RMS current	$\frac{I_{RMS,total}}{I_{cap(rated)}}$	180	$\frac{20}{14.5}$	140
kVAr	$\frac{kVAr_{CAP(wye,total)}}{kVAr_{rated}}$	135	$\frac{13.787kVAr}{10kVAr}$	135

Computing Filter frequency response

Substituting the values of the variables in equation (4.26) from calculated values of each parameter;

$$\sqrt{\frac{21.1}{0.007+0.47}} = 6.65$$

6.65th harmonic is slightly less than fifth harmonic and the severity of parallel resonance would be less compared to if it would be at 7th harmonic.

Checking Voltage rise due to installed capacitor bank.

Voltage improvement due to shunt harmonic filter and capacitor bank installation from equation (3.7) can be rewritten as follows. The result shows during no load condition the capacitor bank cannot cause over voltage and it can be fixed capacitor bank (without switch).

$$\% \Delta V = \frac{kVAr_{cap} * Z_T(\%)}{kVA_T} \tag{4.80}$$

The voltage improvement for transformer on new macaroni processing machineries after 35 kVAr shunt capacitor bank installed could be approximated as follows:

$$\% \Delta V = \frac{35 \text{ kVAr} * 6\%}{1250 \text{ kVAr}} = 0.16\%$$

The voltage improvement for transformer supplying old macaroni processing machineries after 21kVAr capacitor bank installed could be approximated as follows:

$$\% \Delta V = \frac{21 \text{ kVAr} * 6\%}{1250 \text{ kVAr}} = 0.10\%$$

The voltage improvement for transformer supplying pasta processing machineries after 15kVAr capacitor bank installed could be approximated as follows:

$$\% \Delta V = \frac{15 \text{ kVAr} * 6\%}{1250 \text{ kVAr}} = 0.7\%$$

The calculation justifies there could not be a problem of over voltage during no load condition.

4.5. Modelling of the System Using Mat lab Simulink

A model is a representation of the construction and working of some system of interest. It similar to the system but simpler than the system it represents. The three phase model of the loads of the factory can be represented as shown in Figure (4.1). The model contains voltage source coming from the utility, impedance of the service transformer, impedance of the line and the loads. The loads are represented with the current sources. Harmonic sources, which are nonlinear elements, are generally considered to be injection of current sources into the linear network models. They can be represented as current injection sources or voltage sources [2]. For most harmonic flow studies, it is suitable to treat harmonics sources as simple sources of harmonic currents. The designed shunt harmonic filters have been integrated in to the system to improve the distorted waveforms. Simulation results have been shown and explained in accordance to the result obtained.

Three Phase Model of the Source and Current Harmonics

The Mat lab Simulink modeling is used to determine the improvement obtained; through simulation. The simulation results are shown in figure (4.2) _ (4.9). Simulation has been done for two transformers. Both current and voltage harmonics have been simulated before and after the integration of shunt harmonic filters.

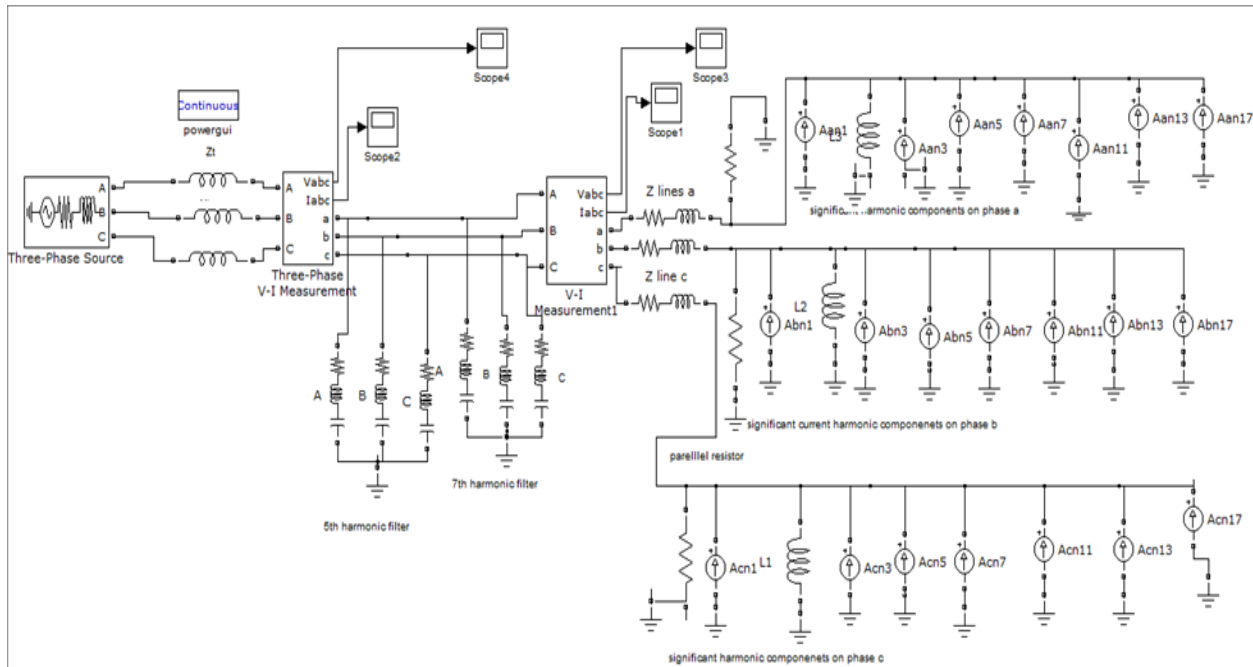

Figure 4. 1: Three phase model for simulation of the system

Figure (4.2) and (4.3) shows simulation of three phase wave forms of current on the transformer supplying new macaroni processing machineries. Figure (4.2) shows the simulated distorted wave forms of current before shunt filters are connected to the model of the system. And figure (4.3) shows the current wave forms after shunt harmonic filters connected (5th and 7th harmonics removed). As it can be seen and compared, the figures show the improvement of the wave form after the filters are connected.

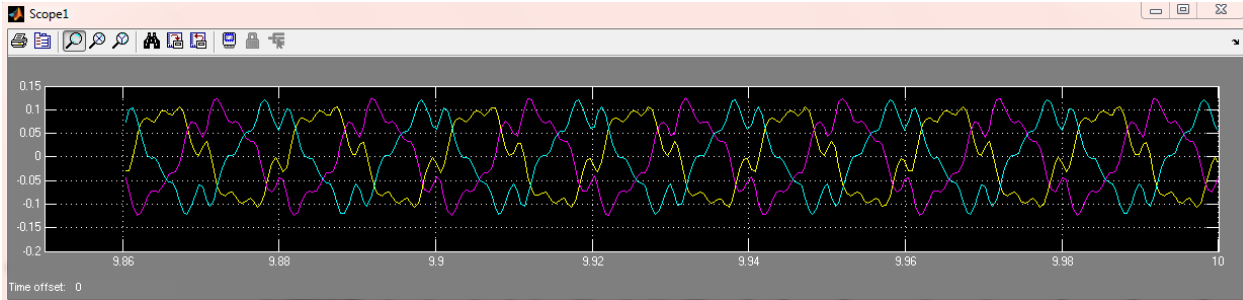

Figure 4.2: Simulation diagram of three phase current wave forms before filter is connected to transformer 1.

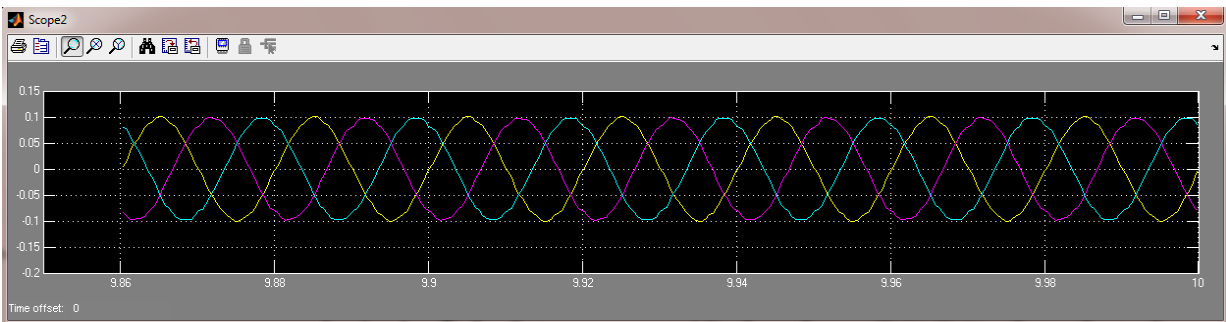

Figure 4.3: Simulation diagrams of three phase current wave forms after filter is connected to transformer 1.

Figure (4.4) and (4.5) shows simulation of wave form of voltage on the transformer supplying new macaroni processing machineries. The voltage harmonic distortion data has been analyzed in chapter three. It has been discussed that the harmonic voltages have been not significant compared to the standards. Figure (4.4) shows the simulated wave forms of voltage before shunt filters connected to model of the system. And figure (4.5) shows the voltage wave forms after shunt harmonic filters connected (5th and 7th current harmonics removed). As already explained in the analysis of data in chapter three, voltage harmonics are not beyond standard. Therefore, the two graphs in figure (4.4) and figure (4.5) look similar.

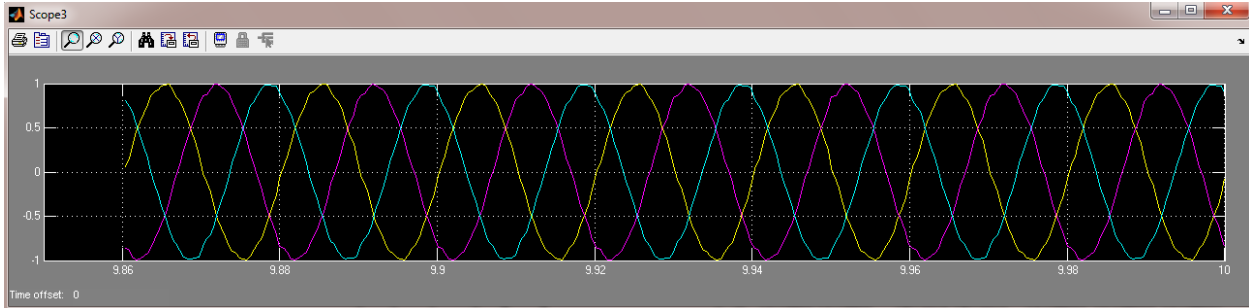

Figure 4.4: Simulation diagram of three phase voltage wave forms before filter is connected to transformer 1.

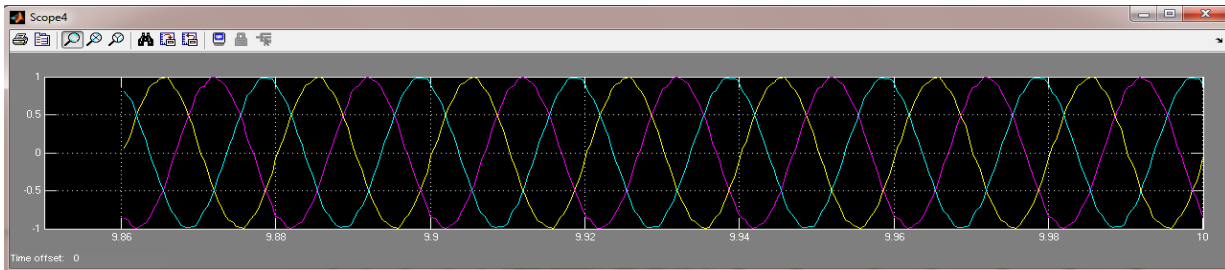

Figure 4.5: Simulation diagram of three phase voltage wave forms after filter is connected to transformer 1.

Figure (4.6) and (4.7) shows simulation of three phase wave forms of current on the transformer supplying pasta processing machineries. Figure (4.6) shows the simulated distorted wave forms of current before shunt filters connected to the model of the system. And figure (4.7) shows the current wave forms after shunt harmonic filters connected (5th and 7th current harmonics removed). As it can be seen and compared, the figures show the improvement of the wave form after the filters are connected.

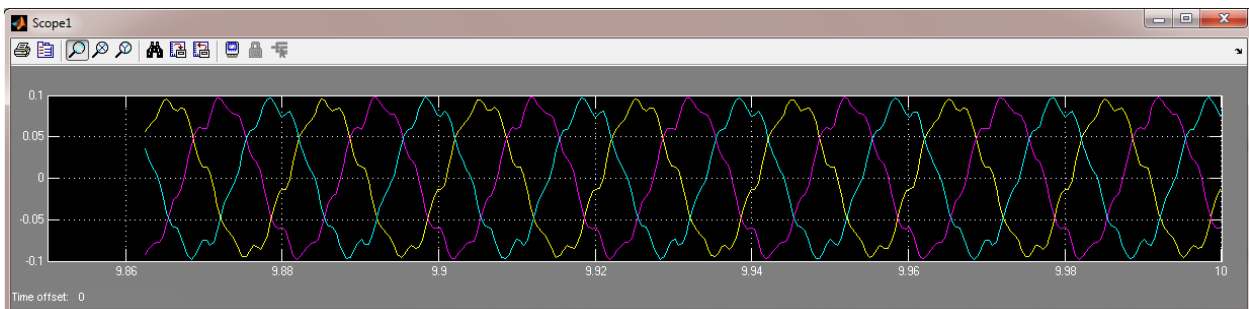

Figure 4.6: Simulation diagram of three phase currents wave form before is connected to transformer 3.

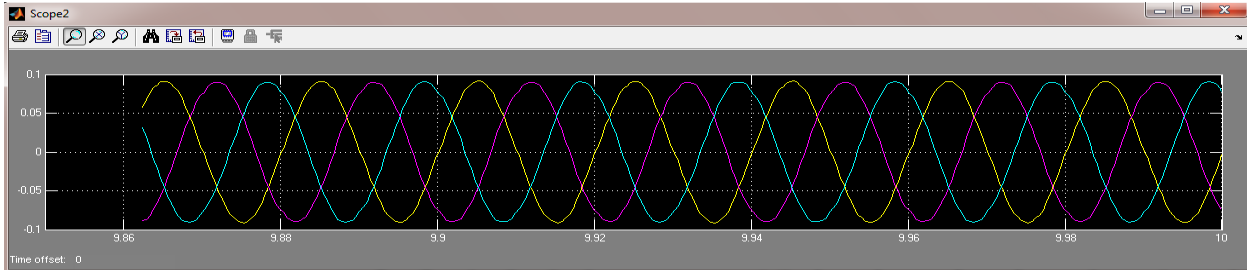

Figure 4.7: Simulation diagram of three phase currents wave form after filter is connected to transformer 3.

Figure (4.8) and (4.9) shows simulation of wave form of voltage on the transformer supplying pasta processing machineries. The voltage harmonic distortion data has been analyzed in chapter three. It has been discussed that the harmonic voltages have been not significant compared to the standards. Figure (4.8) shows the simulated wave forms of voltage before shunt filters connected to model of the system. And figure (4.9) shows the voltage wave forms after shunt harmonic filters connected (5th and 7th current harmonics removed). Again as already explained in the analysis of data in chapter three, voltage harmonics are not beyond standard. Therefore, the two graphs in figure (4.8) and figure (4.9) look similar.

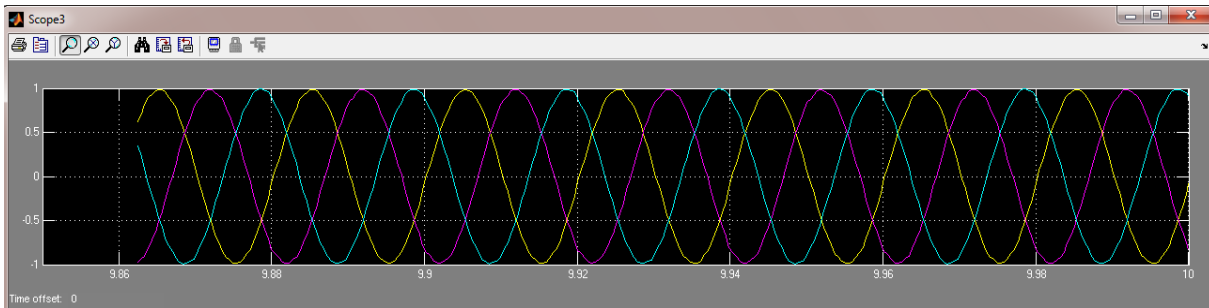

Figure 4.8: Simulation diagram of three phase voltage wave form before filter is connected to transformer 3.

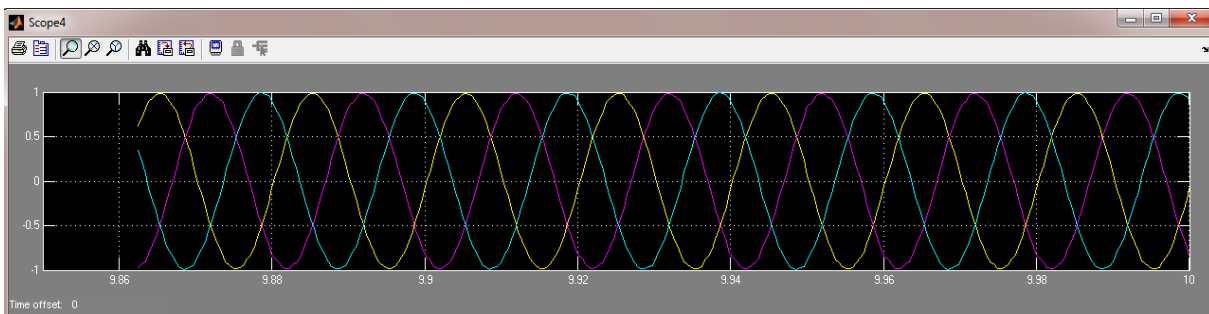

Figure 4.9: Simulation diagram of voltage wave form after filter is connected to transformer 3.

4.6. Loss reduction in the distribution networks

Single tuned shunt harmonic filters are designed for the current harmonic distortion and as a result the harmonic current components which are out of standard are removed. This reduces the losses in the distribution line in the industry.

Shunt harmonic filters reduces most prevalent individual harmonic components to less than fifteen percent (<15%) [4]. Taking the worst case which is 15%, the remaining harmonic currents on each transformer can be calculated as follows. For transformer supplying macaroni processing machines: $I_L=156A$, $I_5=42.6A$, $I_7=36A$

Individual demand distortion of the harmonic components in percent (%) before the harmonic filter connected using equation (2.7) becomes:

$$IDD_5 = \frac{42.6}{156} * 100 = 27.3\%$$

$$IDD_7 = \frac{36}{156} * 100 = 23\%$$

Individual demand distortion of the harmonic components in percent (%) after filtering the harmonic can be calculated as follows:

The remaining 5th harmonic component $\frac{15}{100} * 42.6 = 6.4A$

The remaining 7th harmonic component $= \frac{15}{100} * 36 = 5.4 A$

The individual harmonic components as before, equation (2.7)

$$IDD_5 = \frac{6.4}{156} * 100 = 4\%$$

$$IDD_7 = \frac{5.4}{156} * 100 = 3.4\%$$

The harmonic current filtered out from the system using two filters are $I_5=36A$ and $I_7= 30.6A$.

For transformer on the pasta macaroni processing section feeder:

$I_L=105A$, $I_5=8A$, $I_7=17A$

Individual demand distortion of the harmonic components in percentage (%) before harmonic filtering using equation (2.7) becomes:

$$IDD_5 = \frac{8}{105} * 100 = 7.6\%$$

$$IDD_7 = \frac{17}{105} * 100 = 16\%$$

Individual demand distortion of the harmonic components in percent (%) after the harmonic filter connected can be calculated as follows:

The remaining 5th harmonic component $\frac{15}{100} * 8 = 1.2A$

The remaining 7th harmonic component $= \frac{15}{100} * 17 = 2.55A$

The individual harmonic components will become:

$$IDD_5 = \frac{1.2}{105} * 100 = 1.14\%$$

$$IDD_7 = \frac{2.55}{105} * 100 = 2.4\%$$

The harmonic current filtered out from the system using two filters are $I_5=6.8A$ and $I_7= 14.45A$. The results can be summarized as in table (4.5) below.

Table 4.5: Summary current harmonic distortion before and after filters are connected

Transformers	Individual demand distortion (%)		
	Harmonic order	Before filters connected	After filters connected
On new macaroni	5 th	27.3	4
	7 th	23	3.4
On pasta	5 th	7.6	1.14
	7 th	16	2.4

Loss reduction due to filtered harmonic currents in the factory from loads to transformers

Power loss reduced on the line from load to the factory transformers can be calculated according to the following equation (4.81).

$$P_{loss} = 3R * \sum_{h=2} I_h^2 \tag{4.81}$$

Whereas:

h - Harmonic order

R - Resistance for AC current

Assuming balanced load, harmonic loss reduced by filtering 5th and 7th harmonic currents using equation (4.81) becomes;

For the transformer on new macaroni:

$$P_{saved} = 3 * \left[\frac{0.307hm}{km} * 0.075km * [36^2 + 30.6^2] \right] = 0.154kW$$

For the transformer pasta:

$$P_{saved} = 3 * \frac{0.307 \text{ Ohm}}{km} * 0.075km * [6.8^2 + 14.4^2] = 0.0175kW$$

Loss reduction due to power factor correction

In the three phase system, the apparent power is expressed as:

$$S = \sqrt{3} * U * I = P + JQ \quad (4.82)$$

Neglecting unbalance and distortion the losses can be expressed as:

$$P_{loss} = 3 * I^2 * R \quad (4.83)$$

Solving for I^2 from equation (4.82) power loss becomes;

$$P_{loss} = I^2 * R = R * \frac{(P^2 + Q^2)}{V^2} \quad (4.84)$$

Taking the length of the lines in factory distribution (from service transformer to the loads), 0.075km and $R_2=0.307 \text{ Ohm/km}$ in the factory the power loss can be calculated, using equation (4.83).

Total load current of factory can be calculated as follows:

$$I_1 = \frac{P}{\sqrt{3} * U_h * \cos(\varphi_1)} = \frac{161.44}{\sqrt{3} * 0.38 * 0.78} = 319A$$

$P_{loss} = 3 * R_2 * I_2^2$ for transformer secondary side of the factory

$$P_{loss} = 3 * \frac{0.307 \text{ Ohm}}{km} * 0.075km * (319^2) = 7.03kW$$

$$\Delta P_{\text{loss}} = P_1 \left[1 - \frac{(\cos\phi_1)^2}{(\cos\phi_2)^2} \right] \quad (4.85)$$

The percentage power loss will be given by [17]:

$$\% \text{ Loss reduction} = 100 * \left[1 - \frac{(\cos\phi_1)^2}{(\cos\phi_2)^2} \right] \quad (4.86)$$

Whereas:

- P_1 - Losses before power factor correction
- $\cos\phi_1$ - Power factor before power factor correction
- $\cos\phi_2$ - Power factor after power factor correction

Assuming capacitor banks are installed on the transformer, the loss reduction from utility side becomes the summation of loss reduction from the three transformers.

Transformer on the new macaroni processing section ($\cos\phi_1 = 0.814$ and $\cos\phi_2 = 0.96$)

Transformer on the old macaroni processing section ($\cos\phi_1 = 0.768$ and $\cos\phi_2 = 0.96$)

Transformer on the pasta processing section ($\cos\phi_1 = 0.764$ and $\cos\phi_2 = 0.96$)

Before installation of capacitor banks the total apparent power from the three transformers which has been transmitted from distribution substation from tables (3.8), (3.12) and (3.16) would be calculated as below:

$S_T = 161.44 + 135.217j$ kw at average power factor of 0.78 lagging

The percentage power loss reduction, after power factor corrected to 0.96 can be calculated using equation (4.86) as shown below.

$$\% \text{ loss reduction} = 100 * \left[1 - \frac{0.78^2}{0.96^2} \right] = 36\%$$

Therefore, the correction of power factor to 0.96 reduces the total loss by 36%. Even though energy saving seems small, burning of motors and malfunction of other electrical devices which were caused by harmonic currents would be reduced.

4.7. Economic Analysis of Mitigation Techniques

Power supply authorities apply a tariff system which imposes penalties on the drawing of energy with a monthly average power factor lower than 0.9. The contracts applied are different from country to country and can vary also according to the typology of customer. Generally speaking, the power supply contractual clauses require the payment of the absorbed reactive energy when the power factor is included in the range from 0.7 and 0.9, whereas nothing is due if it is higher than 0.9. For $\cos(\varphi) < 0.7$ power supply authorities can oblige consumers to carry out power factor correction (20).

Ethiopian electric utility requires payment of the absorbed reactive energy when the power factor is included in the range 0.6 and 0.85, whereas nothing due if it is higher than 0.85 but encourages the consumers, industries. If the power factor is less than 0.6 the customers are to be enforced to install capacitor bank. Africa PLC has been paying power factor penalty monthly because of poor power factor. The factory has been paying 2,824birr/ month. And the yearly payment for power factor penalty become 33,888 birr/year

Yearly Cost of energy lost

The total energy lost due to harmonic currents in the factory distribution system only per year would be $2.66 \text{ kW} * 8760 \text{ hr} = 23,302 \text{ kWhr}$

Total cost of energy lost due to I^2R in the factory = $23,302 \text{ kWhr} * 0.5778 \text{ birr/kWhr} = 13,464 \text{ birr}$.

The factory would save about 50,000birr/year.

Total cost of capacitor bank of capacity 70kVAr is about 139,680 birr [21]. The payback period in year using equation (1.1) will be;

$$\text{Payback period} = \frac{139,680 \text{ birr}}{50,000 \text{ Birr/year}} = 2 \text{ years and 9 months.}$$

4.8. Result Discussion

The results of the thesis work are presented by concentrating on the major problems identified and the solutions addressed. This thesis work has assessed the various power quality problems of the Africa plc. From this assessment, power supply interruption, the current harmonic distortion, poor power factor and RMS voltage variation (under voltage) are identified as severe power quality problems that are affecting the factory economically as well as technically. The other

power quality problems like power frequency variations, voltage unbalance, and current unbalance are insignificant compared with the IEEE standard.

Sustained power supply interruption is a common problem in Ethiopia. The factory is using 250kW diesel generator as a stand-by generator. Therefore, there is no need to propose a solution to the problem.

Current harmonic distortion is the main problems in the factory. Measurements are done on the secondary side of the transformer. Compared to the IEEE standard, the total current harmonic distortion levels measured on the new-macaroni and pasta feeders are beyond the standard with the 5th and 7th current harmonic components being significant. The individual current demand distortion for 5th and 7th are 27.3% and 23% on new macaroni section transformer and 7.6% and 16% on the pasta processing section transformer respectively as summarized in table (4.5).

The single tuned shunt harmonic filters are designed for the mitigation of the current harmonic distortion. Using the filters, the 5th and 7th individual demand distortions are reduced to 4% and 3.4% on the new macaroni processing section transformer and to 1.14 and 2.4% on the pasta processing section transformer as summarized in Table (4.5). The factory has been working with poor average power factor, $PF = 0.78$ which is less than Ethiopian electric utility standard, $PF \geq 0.85$. The factory pays about 2,824 Birr for power factor penalty monthly. Using the single tuned shunt harmonic filters installed in the motor control centers and capacitor bank on the transformer supplying old macaroni processing machines the average power factor has been upgraded to 0.96. By applying the proposed solution about 36% of the power which has been lost is now saved. Even though the reduction of loss seems small, the advantages of harmonic filters installed are more than loss reduction. Inefficiency and failure of motors, heating and burning of protective devices would be reduced. The factory has under voltage problem. Since sources of under voltage problem is at the utility level, better solution should be done at the utility level.

Cost analysis has been done for the proposed solution and it will take only two 2 years and 9 months to repay itself. So, it is cost effective.

CHAPTER FIVE

Conclusions, Recommendations and Future Work

Based on the results of the power quality assessments carried out at Africa PLC, the following major conclusions are drawn. In this chapter, useful recommendations are forwarded and the main areas of future work are suggested.

5.1. Conclusions

This thesis work sufficiently described assessment of power quality problems starting with review of literatures; previous research works and collection and analysis of data. Measurements have been conducted to assess the power quality problems at the factory. Based on the data, various analyses have been performed to identify the level of the power quality problems. Then respective solutions have been presented.

From the analysis, it is seen that current THD in the range of 34.4% and voltage THD in the range of 2.9% were measured from the system. The dominant harmonic components are identified to be 5th and 7th harmonics. The gathered data also showed that the factory has been working with poor power factor, 0.78. The Ethiopian Electric Power Corporation charges the factories and industrial customers for the reactive power consumption when the PF is less than 0.85. The factory has been paying a much amount of money for the poor power factor.

Single tuned shunt harmonic filters have been designed to limit the harmonic current injections within tolerable range and to improve power factor. Using the designed mitigation techniques the power factor is upgraded to 0.96 and the dominant harmonics (the 5th and 7th harmonic) orders are reduced to less than 4% (to the tolerable range).

From reliability analysis, it has been seen that the factory has been facing redundant power interruption problem which cause production interruptions. This affects the factory technically and economically. Ethiopian Electric Utility should work hard concerning the electrical power interruption issue.

5.2. Recommendations

The following recommendations are forwarded.

- The Ethiopian Electric power and Ethiopian electric utility should work a lot on the whole power system, from generation to distribution to reduce power quality problems and especial attention should be given to power interruption problem which has been a day to day problem for the end users.
- Factories in Ethiopia need to assess the power quality status of their supply system and sensitivity of their equipment to the power quality problems.

5.3. Suggestions for Future work

This study concentrated on the issues of power quality problems in general. The data were measured from the transformers rather than at terminal of electrical devices in the factory.

The following areas are the issues that need to be further studied.

- Impact assessment of the power quality problems on each and every electrical device
- Detail reliability problems of the factory power distribution networks.

References

- [1]. Thomas J. Dionise, P.E, Thomas M. Blooming, P.E and Daniel J. Carnovale, P.E. “Price and Performance Consideration for Harmonic Solutions”
- [2]. H. Hasanin, Shazly A. Mohammed and Abdel-Moamen M.A” Analysis, Modelling and Simulation of Dynamic Voltage Restorer (DVR) for compensation of voltage quality disturbances” International Journal of Computational Engineering Research (ijceronline.com) Vol.3, Issue 1, 2013.
- [3]. S.V Ravi Kumar and S. Siva Nagaraju, “Simulation of D-STATCOM and DVR in Power Systems” College of engineering, KAKINADA, A.P., India, June 2007.
- [4]. Prakash sundaram¹, Shimi S.L.², Dr.S.Chatterji³ published “Reduction in Harmonics in Marble Industry” International Journal of Innovative Research in Science, Engineering and Technology, Vol. 2, Issue 2, February 2013.
- [5]. Shady A. El- Kashlan and Hussein El-Desouki Saied, “power quality assessment via coordinated voltage control in distributed power generation” International Journal of Electrical and Power Engineering, vol. 3, no. 6, pp. 289-295, 2009.
- [6]. H. Davudi, S. Torabzad, B. Ojaghi, “Analysis of Harmonics and Harmonic Mitigation Methods in Distribution Systems,” Department of Electrical Engineering, Urmia Branch, Islamic Azad University, Urmia, Iran, 2011.
- [7]. Alexander Kusko, Sc.D., P.E. Marc T. Thompson, Ph.D. “Power Quality in Electrical Systems”, McGraw-Hill Companies, 2007.
- [8]. Reger C. Dugan / Mark F. McGranaghan, “Electrical power quality”, second edition, 2004.
- [9]. Mark Mc Granaghan, “Power quality standards”
- [10]. Robert G. Ellis, P.Eng.” Power System Harmonics”, Rockwell International Corporation, Canada, 2001.
- [11]. Michella Weverink, “Mitigation of Voltage Sags in Industrial Power Plants with Medium Voltage DC Distribution System” Department of Electrical Power Processing Delft University of Technology February 2009
- [12]. IEEE Std.1366-2003, “IEEE Guide for Electric Power Distribution Reliability Indices”, 2003

- [13]. ABB SACE, "Power factor correction and harmonic filtering in electrical plants" Technical application papers, July 2008.
- [14]. Robert G. Ellis, P.Eng." Power System Harmonics", Rockwell International Corporation, Canada, 2001.
- [15]. B. A Adegboye, "Power quality assessment in a distribution network", Journal of Advanced Materials Research, 2009.
- [16]. FRANCISCO C.DE LA ROSA, "Harmonics and power system", CRC press, 2006.
- [17]. P. Kundur "Power System stability and control" Tata Mc-grah Hill edition' 2006.
- [18]. Tony Hoevenaars, P. Eng. Kurt Le Doux, P.E. IEEE members and Matt Colosino "Interpreting IEEE Standard 519- and Meeting its Harmonic Limits in VFD Applications", 1995.
- [19]. Taufik, Erin Matsumoto, and Makbul Anwari "Impact of Multiple Adjustable Speed Drive System to Power System Harmonics" 2nd IEEE International Conference on Power and Energy (PECon 08), Johor Baharu, Malaysia, 2008.
- [20]. Thomas M. Blooming,P.E. and Daniel J. Carnovale, P.E." CAPACITOR APPLICATION ISSUES ", Senior Members, IEEE Eaton Corporation.
- [21]. EPCOS Product Profile 2015, [http:// www.epcos.com](http://www.epcos.com)

Appendix A

Table A.1: Spectral current and voltage harmonic components measured value

Transformer	Parameters	Harmonic components							Dominant harmonics
		h=1	h=3	h=5	h=7	h=11	h=13	h=17	
New macaroni	A(pu)	1	0.01875	0.25	0.225	0.0356	0.01865	0.01875	5 th , 7 th
	V(pu)	1	0	0.014	0.017	0.0100	0.0040	0.0048	5 th , 7 th
Old macaroni	A(pu)	1	0	0.01	0.01	0.006	0.0026	0.0028	5 th , 7 th
	V(pu)	1	0.03	0.03	0.02	0.008	0.004	0.002	5 th , 7 th
Pasta	A(pu)	1	0.016	0.06	0.11	0.027	0.0081	0.016	5 th , 7 th
	V(pu)	1	0	0.012	0.006	0.0003	0	0	5 th , 7 th

Table A.2: Ethiopian Electric Utility (EEU) Electricity tariff, Since July 8, 2006.

Tariff	Range of KWh	Multiplier	Tariff	Range of KWh	Flat rate multiplier
10	0-50	0.2730	20	0-50	0.6088
	51-100	0.3564		>50	0.6943
	101-200	0.4993			
	201-300	0.5500	41	LV industry	0.5778
	301-400	0.5666		15KV industry	0.5085
	401-500	0.5880		132KV industry	0.4736
	>500	0.6943			

Appendix B

Table B.1: Electricity interruption history of Adama substation (source: Adama substation, September, 2014 – August, 2015)

No	Feeder	Monthly Av. no. of inter- ruption	Interruption duration (hour)												
			Sept	Oct	Nov	Dec	Feb	Jun	Mar	Apr	May	June	July	Aug	Av.
1	L1	22.25	6.87	10.82	8.22	31.68	20.95	24.4	28.85	25.91	85.22	11.61	15	18	23.96
2	L2	20.25	7.85	11.5	13	24	17	15.03	11.67	19.58	89.87	10	10.38	15.27	20.43
3	L3	18.25	10.25	12.75	16.64	20.28	19.25	6.53	29.05	32.97	64.75	11.58	20.2	13.85	21.5
4	L4	25.75	15.03	6.53	15.08	23.28	12.3	15.08	31.8	44.45	73.80	8.12	10.2	8.78	22.03
5	L5	3.25	10.01	5.33	6.35	17.67	11.03	23.28	8.5	11.08	5.67	2.58	13.28	8.52	10.288
6	L6	11	4.72	5.33	5.6	14.5	11.17	12.3	31.5	14.38	51	16.83	6.78	5.98	15
7	L7	12	6.78	8.38	4.76	5.78	10.18	9.85	22.85	2.17	57.50	10.08	8.87	11.02	13.19

Appendix C

Table C.1: Measured data, harmonic current spectral components (sample data)

Date	Time	(A)A1h1	(A)A1h3	(A)A1h5	(A)A1h7	(A)A1h9	(A)A1h11	(A)A1h13	(A)A1h15	(A)A1h17
		A	A	A	A	A	A	A	A	A
6/4/2015	11:20:00 AM	161.2	5.642	37.7208	27.2428	1.9344	10.1556	5.3196	0.4836	3.8688
6/4/2015	11:30:00 AM	160.3	5.1296	37.1896	26.7701	1.9236	10.0989	5.2899	0.4809	3.8472
6/4/2015	11:40:00 AM	161.2	5.8032	37.7208	26.9204	1.9344	9.9944	5.1584	0.4836	3.8688
6/4/2015	11:50:00 AM	160.3	5.4502	37.5102	26.6098	1.9236	10.0989	5.1296	0.4809	3.8472
6/4/2015	12:00:00 PM	161.5	5.6525	38.437	27.455	1.938	10.1745	5.3295	0.4845	3.876
6/4/2015	12:10:00 PM	160.7	5.1424	40.4964	29.7295	1.9284	12.6953	6.5887	0.1607	3.214
6/4/2015	12:20:00 PM	162.4	6.0088	39.1384	27.7704	2.1112	10.3936	5.3592	0.4872	3.8976

Table C.2: Measured data, harmonic voltage spectral components (sample data)

Date	Time	(V)U1h1	(V)U1h3	(V)U1h5	(V)U1h7	(V)U1h9	(V)U1h11	(V)U1h13	(V)U1h15	(V)U1h17
		V	V	V	V	V	V	V	V	V
6/4/2015	11:20:00 AM	345.8	0	5.5328	6.2244	0	3.458	1.3832	0	1.729
6/4/2015	11:30:00 AM	346.7	0	5.2005	6.2406	0	3.467	1.3868	0	1.7335
6/4/2015	11:40:00 AM	349.8	0	5.247	6.2964	0	3.498	1.3992	0	1.749
6/4/2015	11:50:00 AM	353.3	0	5.2995	6.3594	0	3.533	1.4132	0	1.7665
6/4/2015	12:00:00 PM	351.2	0	5.268	6.3216	0	3.512	1.4048	0	1.756
6/4/2015	12:10:00 PM	353.6	0	4.5968	5.304	0	3.536	1.4144	0	1.4144
6/4/2015	12:20:00 PM	354.2	0	5.313	6.7298	0	3.542	1.4168	0	1.771

Appendix D

Table D.1: Medium line interruption sample data taken from monthly report.

(source: Adama substation)

Date	line	Type of fault	disconnection time	connection time	difference time	hr	Min
1/6/2007	total	black out	9:50	10:10	0:20	0	20
1/6/2007	L3	for work	10:00	10:30	0:30	0	30
1/6/2007	L4	short circuit	8:00	9:23	1:23	1	23
2/6/2007	L4	for work	7:15	7:40	0:25	0	25
2/6/2007	L6	over load	12:30	13:15	0:45	0	45
2/6/2007	L7	for work	15:18	15:20	0:02	0	2
2/6/2007	L2	short circuit	15:50	16:55	1:05	1	5
2/6/2007	L1	Over load	15:55	17:31	1:36	1	36
2/6/2007	L6	overload	19:00	20:50	1:50	1	50
3/6/2007	L4	short circuit	7:05	11:55	4:50	4	50
3/6/2007	L7	short circuit	8:25	13:10	4:45	4	45
3/6/2007	L3	for work	12:00	12:50	0:50	0	50
3/6/2007	L2	overload	19:20	20:10	0:50	0	50
4/6/2007	L1	short circuit	6:50	11:45	4:55	4	55
4/6/2007	L6	for work	10:05	11:35	1:30	1	30
4/6/2007	L5	short circuit	10:55	11:00	0:05	0	5
5/6/2007	L4	over current	7:05	7:20	0:15	0	15
5/6/2007	L3	Over load	7:20	8:05	0:45	0	45
5/6/2007	L2	for work	16:20	16:25	0:05	0	5
6/6/2007	L7	for work	14:00	15:30	1:30	1	30
7/6/2007	L2	overload	12:40	13:55	1:15	1	15
7/6/2007	L3	for work	14:05	14:10	0:05	0	5
7/6/2007	L4	short circuit	18:25	19:35	1:10	1	10