



ADDIS ABABA INSTITUTE OF TECHNOLOGY
SCHOOL OF CIVIL AND ENVIRONMENTAL
ENGINEERING

ASSESSMENT OF THE WATER DEMAND MANAGEMENT OF CONDOMINIUM
HOUSES CONSIDERING GREY WATER REUSE- THE CASE OF MICKEY
LELAND AND JEMO GARA ADDIS ABABA, ETHIOPIA

By

Asmamaw Mekonnen Admasie

A Thesis Submitted to School of Graduate Studies of Addis Ababa University in Partial
Fulfillment of the Requirements for the Degree of Master of Science in Hydraulic Engineering

Advisor

Dr.-Ing. Geremew Sahilu

June 2015

0

Acknowledgements

I would like to thank my supervisor, Dr.-Ing. Geremew Sahilu for his valuable help, support and follow up from the beginning of selecting the title, amending the title, and the whole individual research project period. This study would not have been accomplished without his incredible amount of support.

My greatest appreciation is the joint efforts by Addis Ababa University Institute of Technology department of civil and environmental engineering and Ethiopian Road Authority. I am also indebted special thanks to Addis Ababa Housing Construction Project Office design process experts and design processor for their substantial efforts in supporting to follow up my Msc study.

Last but not least, I would also like to thank Addis Ababa Water and Sewerage Authority Manager to permit laboratory tests, finding the appropriate documents and participating in an interview for the completion of this research, and three special individual, Eng. Ketema Mamo, Eng. Zewdu Abera and Mr. Belachew Nigussie.

ABSTRACT

Supply of adequate amount of water is one of the main challenges facing people that live in Addis Ababa in addition to water quality problems. Currently, it is becoming clear that developing new ground and surface water sources will not be enough to meet these challenges; it is therefore essential to reduce the water consumption, to substitute freshwater with alternative water resources and to optimize water use efficiency through reuse options. Among these alternatives grey water can be used to meet the anticipated deficit. In reality water demand in Addis Ababa exceeds water supply, the water demand in Addis Ababa city is about 736,816m³/day that exceeds the water supply which is about 376,186m³/day, therefore the water deficit is constantly increasing. Based on these facts, Addis Ababa Water and Sewerage Authority jointly to Addis Ababa Housing Construction Project Office need to adopt water demand management of condominium houses considering greywater reuse for efficient use of water.

This research entitle on the assessment of the water demand management of condominium houses considering grey water reuse within the general objective of developing a demonstrator of water demand management in view of grey water recycling based on appropriate piloting and decentralizing grey water treatment technology selection for existing and future construction condominium houses respectively.

Applied methodology consisted of two parts for new and existing condominium houses, in both of them collect secondary data from Addis Ababa Housing Construction Project Office, Addis Ababa Water and Sewerage Authority and reviewing literature from internet. For new condominium houses, using AutoCAD 2007 for separate system designing of grey water and black water riser diagram, laying out a water distribution network potable water and grey water recycling riser diagram; and using an open ended questionnaire surveys were conducted for interviewing professional engineers and managers with grey water recycling. On the other hand for existing condominium houses use closed ended questionnaire surveys were conducted in the cases of Mickey Leland condominium residences to identify the socio-cultural issues and using a barrel plastic piloting grey water treatment technology to know the effluent quality through laboratory test as a demonstrator.

The research result shows that the implementation of grey water reusing would save 376 m³ of potable water per day from Jemo Gara condominium houses with a 3 month payback period, 740.2 m³ of potable water per day from Mickey Leland condominium houses and 141,550.6 m³ of potable water per day from the existing and future condominium houses to flush toilets. The study also demonstrate the different possible socio-technical issues of grey water reuse as part of water demand management and the result shows 96% have a willingness to use the grey water recycling to replace potable water for toilet flushing. It was concluded that the grey water reusing has important, benefits and finding of water demand management of condominium houses to full fill the gap of the water supply and the water demand of the city and it is recommended that for implementing the grey water reuse systems Addis Ababa water and sewerage authority and Addis Ababa housing construction project office must be cooperate to ensure the success of any future water demand management program.

Contents

| | | |
|-------|---|----|
| 1. | Introduction..... | 1 |
| 1.1 | Background..... | 1 |
| 1.2 | Statement of the Problem..... | 3 |
| 1.3 | Research Question | 4 |
| 1.4 | Objectives of the Study..... | 4 |
| 1.5 | Scope of the Study | 4 |
| 1.6 | Significance of the Study..... | 4 |
| 2. | Literature Review..... | 5 |
| 2.1 | General Review on Water Demand Management..... | 5 |
| 2.2 | Socio-Technical Issues of Grey Water Reuse..... | 5 |
| 2.3 | Water Demand Management Considering Grey Water Reusing..... | 6 |
| 2.4 | Grey Water Treatment Technologies for Reusing Grey Water..... | 9 |
| 2.5 | System Description of Grey Water Treatment Technologies | 12 |
| 2.5.1 | Conventional Activated Sludge (CAS) System | 12 |
| 2.5.2 | Extended aeration activated sludge system (EAAS)..... | 14 |
| 2.5.3 | Sequential Batch Reactor System (SBR)..... | 15 |
| 2.5.4 | Trickling Filters (TF)..... | 17 |
| 2.5.5 | Rotating Biological Contactor System (RBC)..... | 19 |
| 2.5.6 | Stabilization Ponds (SPs)..... | 20 |
| 2.5.7 | Moving Bed Biological Reactor (MBBR) System..... | 23 |
| 2.5.8 | Membrane Biological Reactor (MBR) System..... | 24 |
| 2.6 | Consumer Water Demand Management with Social Awareness and Education..... | 26 |
| 2.7 | Water Demand Management with Replacement of Toilet Flushing Cistern | 27 |
| 2.8 | Barrel Plastic Grey Water Treatment Technology..... | 28 |
| 2.8.1 | Two-Barrel Plastic Grey Water Treatment System | 28 |
| 2.8.2 | Four-Barrel Plastic Grey Water Treatment System | 29 |
| 3. | Methodology | 31 |
| 3.1 | Study Area | 36 |
| 3.1.1 | Geographical Location and Area | 36 |
| 3.1.2 | Climate of Addis Ababa City..... | 36 |
| 4. | Grey Water Produced from the Existing and Future Condominium Houses..... | 39 |
| 4.1 | Population Projection in Addis Ababa City..... | 39 |
| 4.2 | Domestic Water Sources of Addis Ababa City..... | 40 |
| 4.3 | Calculating the Water Usage Per Person and Per Household..... | 41 |
| 4.4 | The Amount of Grey Water Produced and that will be Unused per Person and Per Household..... | 42 |
| 4.5 | The Amount of Grey Water Produced in Jemo Gara Condominium Houses | 43 |
| 4.6 | The Amount of Grey Water Produced in Mickey Leland Condominium Houses..... | 43 |
| 4.7 | The Amount of Grey Water Produced from the Existing and Future Condominium Houses | 44 |
| 4.8 | Cost of Water in Addis Ababa..... | 45 |

| | | |
|-----------|---|-----|
| 5. | Socio-Technical Issues of Grey Water Reuse as Part of Water Demand Management..... | 46 |
| 5.1 | Personnel Information in Mickey Leland Condominium Houses..... | 46 |
| 5.2 | Consumer Opinion about Water Services Provided by AAWSA | 50 |
| 5.3 | Consumer Opinion about Grey Water Reusing | 53 |
| 5.4 | Interview Results from Jemo Gara Supervision Professional Engineers..... | 54 |
| 5.5 | Interview Results from Addis Ababa Water and Sewerage Authority Managers..... | 55 |
| 5.6 | Piloting Treatment Technology the Case of Mickey Leland Condominium Houses..... | 58 |
| 5.6.1 | Two-Barrel Plastic Grey Water Treatment technology..... | 58 |
| 5.6.2 | Lab Test Results of Two-Barrel Plastic Grey Water Treatment Technology First Round | 68 |
| 5.6.3 | Lab Test results of Two-Barrel Plastic Grey Water Treatment Technology Second Round | 70 |
| 6. | Selection of Technologies for Grey Water Treatment and System Designs..... | 73 |
| 6.1 | Internal Sanitary Design | 73 |
| 6.1.1 | Separate design of Grey Water and Black Water Riser Diagram | 73 |
| 6.1.2 | Water Supply Riser Diagram Design and Installation | 75 |
| 6.1.3 | Cost Comparisons of Separate Design and Jointly Designing Grey Water and Black Water ... | 76 |
| 6.1.3.1 | Potable Water Saving Potential..... | 76 |
| 6.1.3.2 | Material Cost..... | 76 |
| 6.1.3.3 | Waste Water Treatment Plant Service Saving | 78 |
| 6.1.3.4 | Human Satisfaction..... | 78 |
| 6.2 | Selection of Grey Water Treatment Technologies..... | 78 |
| 6.2.1 | Comparative Analysis of Various Available Grey Water Treatment Technologies | 78 |
| 6.2.2 | Comparison of the Alternative Options | 79 |
| 6.2.2.1 | Comparison Criteria..... | 79 |
| 6.2.2.1.1 | Comparison for Quality of the Grey Water to be Treated..... | 80 |
| 6.2.2.1.2 | Comparison for Land Space Required for Construction..... | 81 |
| 6.2.2.1.3 | Comparison for Protection of the Environment and Odor Nuisance | 81 |
| 6.2.2.1.4 | Comparison for Relative Investment and Running Costs | 82 |
| 6.2.2.1.5 | Comparison for Personnel Skills Required..... | 83 |
| 6.2.2.1.6 | Comparison for familiarity of the technology in the city..... | 84 |
| 7. | Conclusion and Recommendation | 87 |
| 7.1 | Conclusions..... | 87 |
| 7.2 | Recommendations..... | 88 |
| 8. | Reference | 89 |
| | Appendix –A- Amount of Grey Water Produced | 92 |
| | Appendix –B- Laboratory Test Results | 96 |
| | Appendix –C- Questionnaire in Mickey Leland Condominium Residences | 106 |
| | Appendix –D- English Questionnaire Translation to Amharic Questionnaire | 107 |
| | Appendix –E- Questionnaire for Interview..... | 108 |
| | Appendix –F- Separate Design of Grey Water and Water Supply Riser Diagram..... | 109 |

List of Table

| | |
|---|----|
| Table 1: Distribution of Water Use in Boulder, Colorado..... | 6 |
| Table 2: Constituents of Grey Water from Various Household Sources..... | 9 |
| Table 3: Effluent Quality from 2- Barrel System (Households No 1)..... | 30 |
| Table 4: Effluent Quality from 4- Barrel System (Households No 6)..... | 30 |
| Table 5: The Costs to Incur for the System..... | 30 |
| Table 6: Population Growth of Addis Ababa City from 2008-2020..... | 39 |
| Table 7: Number of Typologies and Total Number of Houses in Ten Sub-Cities of the Metropolis..... | 40 |
| Table 8: Percentage Composition of Per-Capita Water Demand for Different Purposes..... | 41 |
| Table 9: Composition of Per-Capita Water Demand for Different Purposes..... | 41 |
| Table 10: Grey Water Usage per Person..... | 42 |
| Table 11: Number of Typologies, Houses and Hectares in Jemo Gara Condominium Houses..... | 43 |
| Table 12: The Number of Customers and the Amount of Water Delivered in Mickey Leland..... | 43 |
| Table 13: Summary of Amount of Grey Water Produced..... | 44 |
| Table 14: Cost of Water and tariff group in Addis Ababa..... | 45 |
| Table 15: Total Cost Incurred to Install the Barrel Plastic Piloting Treatment Technology..... | 59 |
| Table 16: Effluent and Influent Quality from 2- Barrel System..... | 69 |
| Table 17: The Standards Which Shall be Applied to all Effluents Discharge to Inland Waters..... | 70 |
| Table 18: The Greye Water Standards Which Shall be Reuse the Effluents to Indoor and Outdoor..... | 70 |
| Table 19: Effluent and Influent Quality from 2- Barrel System (collecting 31 Households)..... | 71 |
| Table 20: Summary of the Effluent and Influent Quality Average Result from 2- Barrel System..... | 71 |
| Table 21: Comparison of Water Supply PPR Pipes in One Block in Jemo Gara..... | 76 |
| Table 22: Comparison of Supplying PPR pipes in 46 Blocks in Jemo Gara..... | 77 |
| Table 23: Comparison of Black Water and Grey Water Riser Pipes in One Block in Jemo Gara..... | 77 |
| Table 24: Comparison of Black Water and Grey Water Riser Pipes in 46 Blocks in Jemo Gara..... | 77 |
| Table 25: Material Cost Comparison Summary of Separate Design of Grey Water and Black Water..... | 78 |
| Table 26: Comparison Matrix (Criteria and Weight factors)..... | 80 |
| Table 27: Comparison of the Alternative Process Option for Quality of the Grey Water..... | 80 |
| Table 28: Comparison of the Alternative Process Option for Land Space Required..... | 81 |
| Table 29: Comparison of the Alternative Process Option for odor nuisance..... | 81 |
| Table 30: Comparison of the Alternative Process Option for Running Costs..... | 82 |
| Table 31: Comparison of the Alternative Process Option for Personnel Skills Required..... | 83 |
| Table 32: Comparison of the Alternative Process Option for Familiarity of the Technology..... | 84 |
| Table 33: Summary of Scores from the Comparison of Different Alternative Options..... | 85 |

List of Figures

| | |
|--|----|
| Figure 1 : Water in Residences with Centralized Systems without Water Recycling | 2 |
| Figure 2 : Water in Residences with Centralized Systems with Water Recycling | 2 |
| Figure 3 : Grey Water Component Illustration | 8 |
| Figure 4 : Grey Water Treatment for Reuse in House Hold | 11 |
| Figure 5: Typical Composition of Waste Water | 12 |
| Figure 6: Conventional Activated Sludge Flow Chart..... | 13 |
| Figure 7: Extended Aeration Activated Sludge System..... | 14 |
| Figure 8: Sequential Batch Reactor System Operation Phases | 16 |
| Figure 9: Typical Configuration and Main Parts of a Trickling Filter with Rocks Medium | 18 |
| Figure 10: Rotating Disc Arrangement..... | 19 |
| Figure 11: Typical WSPs Configuration Series..... | 21 |
| Figure 12: Waste Stabilization Ponds | 22 |
| Figure 13: Typical MBBR Treatment Scheme for Pre-denitrification and Carbonation/nitrification | 23 |
| Figure 14: MBBR Bio-Carrier and Retaining Sieves | 24 |
| Figure 15: Membrane Configuration of MBR | 25 |
| Figure 16: Two-Barrel Treatments Units..... | 28 |
| Figure 17: Four-Barrel Treatment Units | 29 |
| Figure 18: Location Map of Africa, Ethiopia and Addis Ababa..... | 37 |
| Figure 19: Satellite Image Map of Mickey Leland Condominium Site within Kolfe Keraniyo Sub City.. | 37 |
| Figure 20: Location of Jemo Gara Condominium Site to be Constructed in Kolfe Keranio Sub City..... | 37 |
| Figure 21: Location Map of Existing Condominium Houses in Addis Ababa City Map | 38 |
| Figure 22: Addis Ababa City Map Including 10 Sub Cities..... | 39 |
| Figure 23: Category of Occupation..... | 47 |
| Figure 24: Category of Sex | 47 |
| Figure 25: Category of Age | 48 |
| Figure 26: Number of Family Members | 48 |
| Figure 27: Educational Level..... | 49 |
| Figure 28: Income Categories for Mickey Leland Condominium Residence..... | 49 |
| Figure 29: Monthly Water Bills in Mickey Leland Condominium Residence | 50 |
| Figure 30: Water Shortage Problems | 51 |
| Figure 31: Using Bit to Save Water | 51 |
| Figure 32: Options to Get Water during the Absence of Water..... | 52 |
| Figure 33: Description of the Community Regarding Water Use..... | 52 |
| Figure 34 : Methods Using for Washing Clothes | 53 |
| Figure 35: Spilling Out of Wastes from Cloth Washing..... | 53 |
| Figure 36: Willingness's to Reuse Grey Water Using a Piloting Treatment Technology | 54 |
| Figure 37: Existing Waste Water Design | 73 |
| Figure 38 : Separate Design of Grey Water and Black Water..... | 74 |
| Figure 39 : Existing Potable Water and Additional Grey Water Supply Design..... | 75 |

| | |
|---|----|
| Figure 40: Ranking the Alternative Technologies Based on the Quality of the Grey Water..... | 80 |
| Figure 41 : Ranking the Alternative Technologies Based on the Land Required for Construction..... | 81 |
| Figure 42 : Ranking the Alternative Technologies Based on the Odor Nuisance..... | 82 |
| Figure 43 : Ranking the Alternative Technologies Based Costs..... | 83 |
| Figure 44 : Ranking the Alternative Technologies Based on the Personnel Skills Required | 83 |
| Figure 45: Ranking the Alternative Technologies Based on the Familiarity of the Technology..... | 84 |
| Figure 46 : Summaries Scores from the Comparison of the Alternative Treatment Technologies | 85 |

Abbreviation and Acronyms

| | |
|------------|---|
| AAHCPO | Addis Ababa Housing Construction Project Office |
| AAWSA | Addis Ababa Water and Sewerage Authority |
| AWA | Australian Water Association |
| AWWA | American Water Works Association |
| BW | Black Water |
| CPUT | Cape Peninsula University of Technology |
| CSA | Central Statistical Agency |
| E.C | Ethiopian Calendar |
| EPA | Environmental Protection Agency |
| ETB | Ethiopian Birr |
| G.C | Gregorian Calendar |
| GTZ | German Technical Corporation |
| GW | Grey Water |
| HCPO | Housing Construction Project Office |
| IHDP | Integrated Housing Development Program |
| MENA | Middle East and North Africa Region |
| PSASP | Policy Study and Analysis Sub Process |
| PW | Potable Water |
| UN-HABITAT | United Nations Human Settlement Program |
| USEPA | United States Environmental protection Agency |
| WDM | Water Demand Management |

CHAPTER 1

1. Introduction

1.1 Background

Rapid urbanization, climate change and higher living standards have led to continuous growth of Addis Ababa water supply. Globally Water Demand Management (WDM) is slowly coming to be recognized as an essential complement to supply management if fresh water is to be used in a sustainable manner. WDM has been shown to yield economic benefits through increasing efficiency as well as, in many cases, greater equity, reduced environmental damage, and greater public participation. Unfortunately, lack of clarity about what constitutes water demand management – and how it can be effectively introduced in different of sectors, regions, and cultures – is blocking its ability to play as great a role as it should in water policies and programs around the world (David, 2005).

Water demand management more an issue of policy than of technology, it is about managing and moderating our demands for good quality fresh water. It is less a matter of piping and pumps and more a tool for changing the ways we use water and the rates at which we use it. In practice, WDM comes down to three key goals: efficiency, equity and sustainability. There are many ways to improve the efficiency of water use, for example by reducing losses in the distribution system, by reducing the amount or the quality of water needed to perform a task, and by changing the timing of water use. Reducing the amount of water used is an obvious benefit. Any strategy for the implementation of WDM must take into account the goal of social equity. A key element is the sensitive issue of water pricing, and ensuring that poverty is not a barrier to reasonable access to clean water. Responses to the needs of the poor will vary depending on the setting. No other region of the world has so many people striving so hard for economic growth (sustainability) with so little water than the Middle East and North Africa Region (MENA). MENA has five percent of the world's population but only one percent of its fresh water (Wadimena, 2011).

An important purpose of water management is to match or balance the demand for water with its availability, through suitable water allocation arrangements, and there is a large number of often conflicting of water uses including; domestic use in urban centers, irrigation, domestic use in rural areas, livestock, industrial use, commercial use, the environment (e.g. in stream flow requirements for aquatic life and wildlife), institutions (e.g. schools, hospitals), hydropower, cooling (e.g. for thermal power generation), waste and wastewater disposal, fisheries, recreation and navigation. In many Southern African countries there have been significant reforms in the way in which water is managed. One aspect of these water reforms in southern Africa is increased stakeholder participation in water management (CPUT, 2006).

The Integrated Housing Development Program (IHDP) currently Addis Ababa Housing Construction Project Office (AAHCPO) is a government-led and financed housing provision programmed for low-and middle-income households in Ethiopia. The program was launched in 2004 (1996 in the Ethiopian calendar). The Addis Ababa Housing Construction Project Office considers four unit typologies incorporated into each condominium block: a studio, 1-bedroom, 2-bedroom, and 3-bedroom unit types.

Each unit includes a bathroom, which includes a shower, flush-toilet, and basin, and a separate kitchen. Each unit has water, sewerage, and electricity connections. The provision of communal building to condominium sites was an attempt to respond to the cultural needs of residents. The function of the communal building is to provide a protected space for residents to perform traditional tasks such as slaughtering goats, and cooking extensive meals: activities the housing units themselves cannot accommodate (UN-HABITAT, 2011).

Addis Ababa city has very limited resources of surface and ground water which plays an important role in the support of domestic needs in mass condominium houses. Therefore WDM measures in mass condominium houses can be succeeded with grey water reuse as the system shown in figure 1 and in figure 2 below, possible socio-technical issues of grey water reuse as part of water demand management and proper selection of technologies for grey water treatment options. This is possible by investigation of the amount of grey water recycling by gathering data from Addis Ababa housing construction project office (AAHCPO), designing questioner for data collection from the consumer by considering several issues which is fully addressed in chapter three and chapter five.

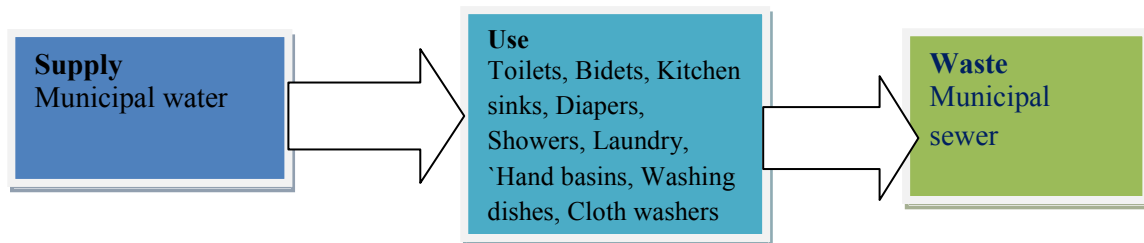

Figure 1 : Water in Residences with Centralized Systems without Water Recycling (Katie, 2010)

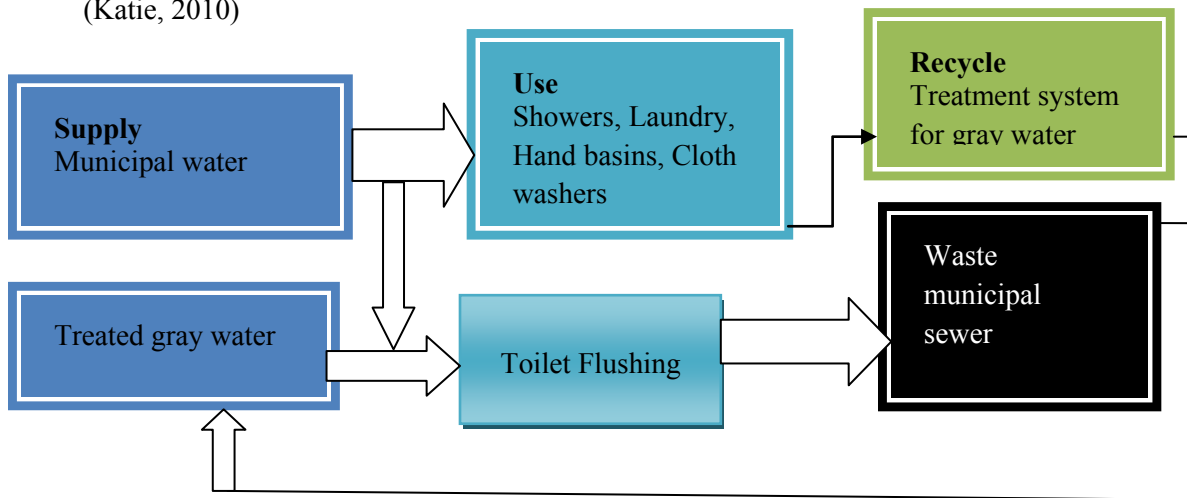

Figure 2 : Water in Residences with Centralized Systems with Water Recycling (Katie, 2010)

1.2 Statement of the Problem

The current problem for Addis Ababa Water and Sewerage Authority (AAWSA) is related to the fact that, **water demand** for Addis Ababa is now greater than **water production** capacity and on the other hand the city government of Addis Ababa Housing Construction Project Office (AAHCPO) is engaged in the construction of condominium housing apartments in ten sub-cities of the metropolis in an effort to reduce the problem of housing in the city targeting **886,978** housing unit in 2020 E.C. However, the availability of adequate and safe water supply is among the basic and essential elements in any housing development program.

The city of Addis Ababa is at present supplied from surface water from Legedadi, Dire and Gefersa dams with additional supplies from ground water pumped from Akaki well fields to the south of Addis Ababa, and other wells and springs within the city.

Surface water from Legedadi and Dire dam is treated at Legedadi water treatment plant having a production capacity of 195,000m³/day while that from Gefersa dam is treated at Gefersa water treatment works having production capacity of 30,000 m³/day. Similarly, the collective groundwater production from Akaki well fields and other boreholes within and around the city is estimated as 222,333m³/day. Therefore, the total current water production is about **447,333m³/day**. (Source: Addis Ababa Water and Sewerage Authority). However, the current estimated water demand of the city is about **736,816m³/day**. (Sources – Addis Ababa Water Supply Project – Stage IIIA). This indicates that it is very far to reach the demand of the city.

It is therefore essential to reduce the water consumption, to substitute fresh water with alternative water resources and to optimize water use efficiency through reuse options. Among these alternatives **grey water** can be used to meet the anticipated deficit. Grey water is commonly defined as wastewater generated from shower, hand basins and cloth washing which accounts **40.3 %** of the outflow from homes.

Before being reused, grey water must be treated, using a variety of treatment technologies of varying sophistication, to a quality where it can be reused for intended applications such as for toilet flushing, gardening, car washing, floor cleaning, etc. The grey water treatment processes can involve right from simple low-cost devices to highly complex and advanced biological treatment processes incorporating sedimentation tanks, bioreactors, filters, pumps and disinfection systems.

Therefore, the main purpose of this research is to demonstrate the benefits of grey water reuse; using a barrel plastic grey water treatment technology for old /existing/ condominium houses that can be tested in lab, water tests to know and to compare the influent and effluent grey water quality of the parameters BOD₅, TS, TSS, TDS, TVS, COD, DO in mg/l and PH values and for new /future construction/ condominium houses selection of decentralized grey water treatment technology is applicable to Addis Ababa condominium houses. With the increasing demand for freshwater, this strategy substitute potable water for example, toilet flushing, gardening and other water needs, increasing its availability for other primary uses.

1.3 Research Question

- How easy is greywater recycling in terms of meeting the required water particularly for toilet flushing purposes?
- What is the opinion and functionality (performance) of the residents of the condominium houses of water demand management considering with grey water reuse?
- Is there any technologies and limitations for implementing of grey water treatment options?

1.4 Objectives of the Study

General Objective

The general objective of this research is to demonstrate the water demand management in mass condominium housing development sites located in Addis Ababa city in view of grey water recycling based on appropriate grey water treatment technology.

The specific objectives of this research are:

1. To determine the amount of grey water reuse from the existing and future condominium houses.
2. Identify different possible socio-technical issues of grey water reuse as part of water demand management.
3. To select and demonstrate appropriate greywater recycling treatment technology options.

1.5 Scope of the Study

This study investigated the amount of grey water production and reuse to supplement the water supply for condominium houses. The reuse could be used for general domestic water use or mainly for flushing of toilet or gardening depending on the effluent water quality and acceptability of community. The study also investigates suitable grey water treatment technologies that are applicable to condominium housing site which will be also acceptable to AAWSA standards. In addition, the study will consider the grey water reuse system designs that will be applicable to the selected condominium housing site. Finally, both technical and financial feasibility will be shown. However, the study could not consider any other water demand management options unless listed in the objectives.

1.6 Significance of the Study

The main significance of the study is to produce good understanding for water resource planner, decision makers, stakeholders, water users and any concerned person to the significance on water demand management variables (such as grey water reusing, possible socio-technical issues of grey water reuse and proper selection of technologies for grey water treatment options) and the impact of those have on water resource system performance and provide possible assessment measures to cope up with the problems. Hence, the need to assess the importance of water demand management is more possible than supplying more water to the water users using possible utilization methods to improve water demand management and the likely possible water productivity improvement.

CHAPTER 2

2. Literature Review

2.1 General Review on Water Demand Management

Water demand management refers to the adaptation and implementation of a strategy by a water institution or consumer to influence the water demand and usage of water in order to meet any of the following objectives: Economic efficiency, Social development, Social equity, and Environmental protection, Sustainability of water supply and services, and Political acceptability. The three divisions of water demand management strategies can be categories; socio-political, economic and structural-operational.

Socio-political: since many users are not familiar with the value of water and there is no reduction of water demand in order to inform and changes the consumer behavior ; socio-political type of strategies changes the water users' behavior towards water usage and water wastage using and accomplishing the public by education programs or media for awareness on WDM.

Economic: economic measures are based on the theory that water apart from a social good is an economic good. Hence an increase in water price would theoretically result in a lower consumption of water. In addition to increasing the water price, it includes penalties for excessive water use to supplement the bill price for financial incentives for efficient use of water.

Structural-operational: Structural-operational includes engineering and technological solutions that aim to reduce water consumption without lowering the level of service to the consumer. Which includes the promotion of water efficient devices, alternatives to water supply for example, rainwater harvesting, water recycling and adoption of plants that require less water.

2.2 Socio-Technical Issues of Grey Water Reuse

The high willingness among university students to accept recycled water systems for no potable water to reveals an opportunity in Pretoria, South Africa to substitute water sources with community support. University students appear to be very supportive of using recycled water for non-potable purposes which and would produce costs and energy use through only treating water to a level appropriate for the subsequent use. The opportunity for source substitution is particularly significant with regards to water use for toilet flushing given that the survey showed 97 % of university students would approve of using recycling water for this purpose. Approximately 63% of the water used in public environments or offices is for flushing toilets. Replacing the current potable water stream with reused water would significantly reduce the demand for potable water on university campus (Alison, 2013).

The public perception on grey water recycling surveyed in England about 300 respondents which were distributed sufficiently to ensure that the findings of the survey were representative of the population. Over all the survey revealed a broad willingness to accept urban recycling as long as public health is not

compromised. The percentage of respondents willing to recycle is 88% for toilet flushing, whereas 12% of the survey revealed a willingness to accept for drinking (Jefferson, 2004).

2.3 Water Demand Management Considering Grey Water Reusing

Anthony (May 2011) quantifying the benefits of grey water systems in Georgia stated on the American water works association website (2010) the use of grey water has the ability to reduce water usage an additional 26.7% if only used for toilet flushing. Out of 100%, 34% of the fresh water used in the United States is used for irrigation. This 34% is the second largest percentage only preceded by thermoelectric at 48%. It should be noted that this 34% of water usage is used for agricultural irrigation. Reducing the amount of potable water for residential landscape irrigation should be a very high priority (Anthony, May 2011).

Replacing potable water with grey water for flushing toilets increases water efficiency in buildings. An evaluation of water savings, environmental, economic, and policy impacts of gray water reuse systems as exemplified in a campus residence hall, Williams Village North, housing 500 students at the University of Colorado Boulder. Treatment of shower and sink drainage and recirculation for toilet flushing is estimated to reduce water use in the building by 20%, an amount 3,300 m³/year. At municipal water and wastewater utility rates, the annual savings are around \$6,000 and will not provide a reasonable return on investment for the capital cost of the dual plumbing and treatment systems (Marie, 2012).

Table 1: Distribution of Water Use in Boulder, Colorado.

| Use | Gallons per Capita/day | % of Total |
|---------------------|------------------------|-------------|
| Baths | 1.4 | 2.16% |
| Clothes Washers | 14 | 21.57% |
| Dishwashers | 1.4 | 2.16% |
| faucets | 11.6 | 17.87% |
| Leaks | 3.4 | 5.24 |
| Showers | 13.1 | 20.18% |
| Toilets | 19.8 | 30.51% |
| Other domestic | 0.2 | 0.31% |
| Total Indoor | 64.9 | 100% |

N.B 1 gallon = 3785 cubic centimeters = 3.785 liter

Each of the uses shown in table 1 can be reduced through the installation of water efficient devices and fixtures (Marie, 2012).

According to Anthony (2011) stated from Ludwig (2011), Friedler (2005) and Rose (2005) grey water system comes in all shapes and sizes from an untreated bucket in a shower to commercial units housing thousands of gallons of grey water, although diverse in from the system have evolved to have just a few major components. The first consideration is that waste water piping must be separated from reasonable to very difficult to retrofit. As an example, in a typical second story residential home with basement the

grey water system can be installed in the basement. Drain lines from first floor bath room sinks and showers can be diverted from the sewer system and redirected to the grey water reservoir .The filter and treated water can then be pumped to first floor toilets. Gathering second floor grey water and pumping to second story toilets would be much more invasive and expensive project .The first floor project can happen very easily without affecting the first floor living space. After the main lines and sewer lines are separated, the grey water will go through some level of particulate filtration. This can be as simple as a residential sock with 3000 micro fibrous filter to as advanced as a multi-phased filtration system.

The water is emptied into a reservoir after particulate filtration has taken place. Residential units range from 1-5 gallon tanks to over 5000 gallon underground tanks. Some systems utilize septic tanks to hold grey water. Commercial systems start at 500 gallons up to thousands of gallons. The water is chemically treated; some commercial units are chemically treated prior to being tanked. Most is treated once tanked, the chemical treatment is typically done with a sodium hypochlorite product concentrate like chlorine or households bleach. The chemical treatment is accomplishes killing bacteria, viruses, parasites, algae, and molds. The grey water is now considered safe for reuse as toilet water. The final component is a pump; this can range from a sump pump to a pumping station (Anthony, 2011).

Two capacities are critical for a grey water system to work properly as shown in figure 3. The first is to connect a valve municipal potable water sources to the system .This will guarantee that water will always be available when needed even when grey water production is insufficiently low. The second critical consideration is for an over flow to be installed at the grey water system's reservoir tank that would be connected to the municipal sewer system. This is necessary if more grey water is produced than is needed. This second scenario is more prevalent than the first in a properly sized system (Anthony, 2011).

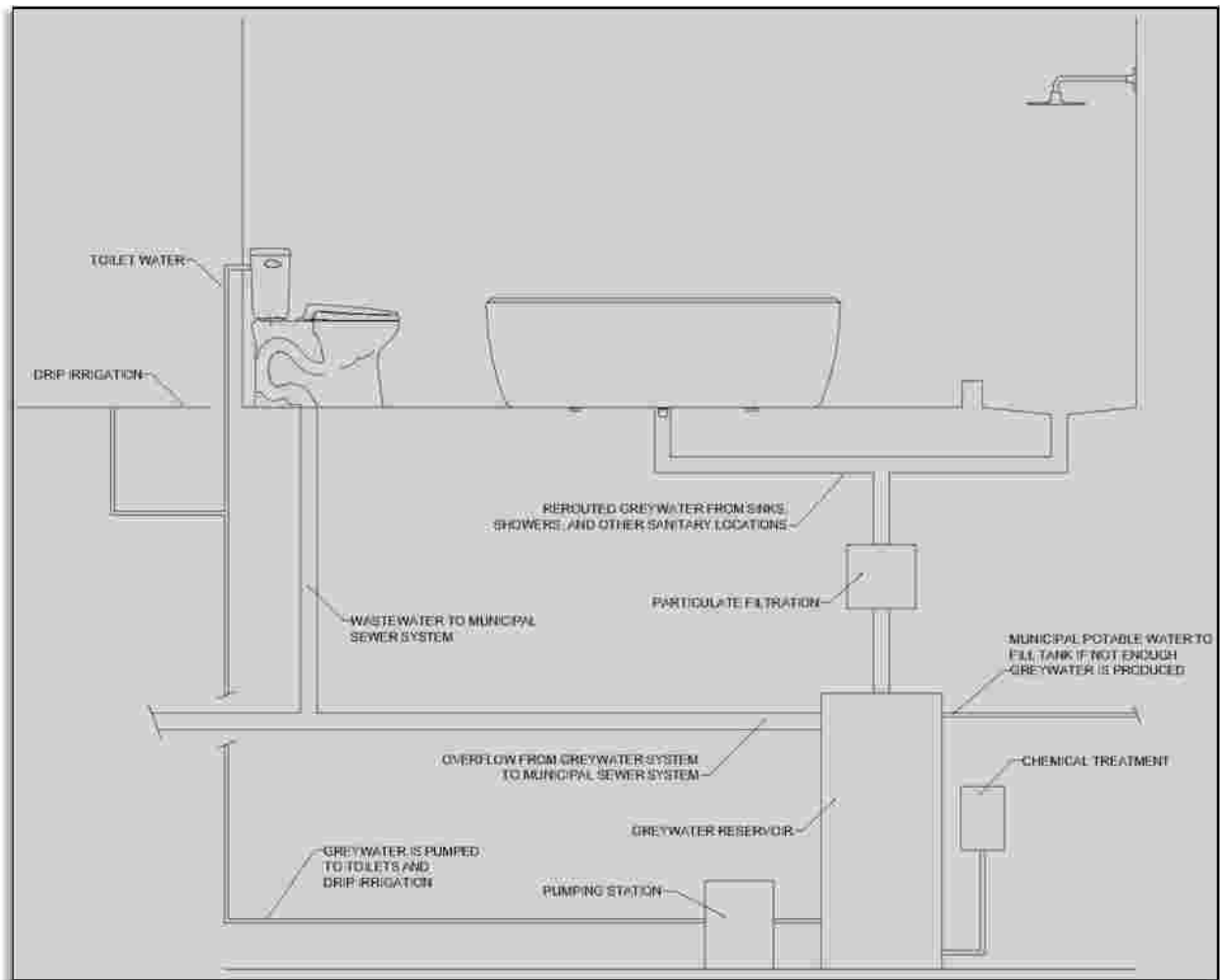

Figure 3 : Grey Water Component Illustration

The recycling of grey water involves filtering and cleaning the water to a quality that allows a second use, such as flushing toilets, irrigation, even drinking if cleaned and disinfected to an acceptable quality level.

- ☞ Strength of grey water
 - Reduces fresh water usage by large margins and simple principle and simple solution.
- ☞ Weaknesses of grey water
 - High initial cost to implement and significant and new infrastructure
- ☞ Opportunities of grey water
 - Save significant money on water bill and accolades for efforts in sustainability
- ☞ Threats of grey water
 - Feasibility exists in water /plumbing markets and government regulation, health and safety.

According to Kirsten stated from Hills et al (2002) the first reclamation for water recycling in buildings for toilet flushing in England was provided 55 % of the 131,000 m³ of water used at the site, in the form of grey water from washroom sinks in the building (10%), rain water collected from the dome roof (19%),

and ground water (71%), all treated on site. The volume of grey water produced was less than the predicted, limiting its contribution, and the amount of rainwater that could be collected was limited by storage constraints on site.

2.4 Grey Water Treatment Technologies for Reusing Grey Water

The quality of grey water between households, and even within households, varies daily depending on the activities of the house hold's occupants. In addition, the quality of grey water varies depending on the source of the water as shown in the table below. For most households grey water contains soap, shampoo, toothpaste, shaving cream, laundry detergents, hair, lint body oils, dirt, grease, fats, chemicals (from soap, shampoos, cosmetics) and urine. Grey water also contains bacteria, parasites and viruses washed from the body and clothes.

Table 2: Constituents of Grey Water from Various Household Sources

| Grey water sources | Possible contents |
|--------------------------|--|
| Automatic clothes washer | Suspended solids (dirt, lint), organic material, oil and grease, sodium, nitrates and phosphates (from detergent), increased salinity and PH, bleach |
| Automatic dishwasher | Organic material and suspended solids (from food), bacteria, increased salinity and PH , fat, oil and grease, detergent |
| Bathtub and shower | Bacteria, hair , organic material and suspended solids (skin particles ,lint), oil and grease, soap and detergent residue |
| Sinks, including kitchen | Bacteria, organic matter and suspended solids (food particles), fat, oil and grease, soap and detergent residue |

Considering the possible contents from grey water sources there are reasons why grey water may need to be treated, to remove substances that may be harmful to human health, plants and oil, to the environment and clog the irrigation system.

The choice of the grey water treatment depends on the owner's willingness to operate and maintain the facility; the source of grey water to be recycled; and the purpose of the grey water reuse whether for subsurface irrigation or sprinkler irrigation or for toilet flushing or waterfalls (WHO, 2006).

According to WHO (2006); using secondary treatment systems such as active sludge and constructed wet land; in Swedish grey water treatment plants ,a 50% -98% reduction in different microorganisms was observed in the active sludge treatment process.

Due to increasing water scarcity in many regions around the world new water sources are developed ,namely ;seawater desalination and exploitation of more distance (surface water) and deeper (ground water) sources. Not only that the cost of utilizing these sources is due to be higher than the cost ,conventional ,water sources ,but they have increasing negative environmental effects. For example: seawater desalination results in increasing CO2 and other pollutants emission to the atmosphere and causes disturbance to the adjacent marine environment. An alternative to the above is to enhance

utilization efficiency of water, to promote water saving measures and to reuse water from an alternative resource.

Domestic in-house water demand in industrialized countries consists of 30-60% of the urban water demand and ranges between 100 to 150 l/c/d (liter/capital/day), of which 60-70% is transformed into grey water, while most of the rest is consumed for toilet flushing. Grey water reuse for toilet flushing (if implemented) can reduce the in-house net water consumption by 40-60l/c/d, and urban water demand by up to 10-25%, which is a significant reduction of the urban water demand (additional reuse for garden irrigation may further reduce the overall demand (Friedler, 2005).

In Israel following the above considerations, a pilot plant treating light grey water (which incorporates biological treatment) was constructed (Friedler et al. (2005)). The overall performance of the pilot plant was excellent, producing effluent of very high quality that well meets the „excellent –quality „category set by the Israeli Ministry of Health (2003) in their urban effluent reuse regulations.

In India there is a water crisis and by 2025 it is estimated that India's population will be suffering from severe water scarcity. Although India occupies only 3.29 million km² geographically area which forms 2.4% of the world's land area, it supports over 15% of world's population with only 4% of the world's water resources. With increased population growth and development, there is a need to critically look at alternative approaches to ensure water availability. These alternative resources include rain water and grey water. At house hold level, treated grey water can be recycled for garden washing and flushing purposes (Lambe, 2008).

According to Lambe S. and Chougule S, water used in hand washing and bathing generates around 50-60% of total grey water and is considered to be the least contaminated type of grey water. Common chemical contaminants include soap, shampoo, hair dye, toothpaste and cleaning products. It also has some faecal contaminant (and the associated bacteria and viruses) through body washing. Water used in cloth washing generates around 25-35% of total grey water and kitchen grey water contributes about 10% of the total grey water volume. It is contaminated with food particles, oils, fats and other wastes. Hence from the above considerations grey water reuse treatment can range from low cost methods such as the manual bucketing of grey water from the out let of bath room, to primary treatment methods that coarsely screen oils, greases and solids from the grey water before irrigation via small trench systems, to more expensive secondary treatment systems that treat and disinfect the grey water to a high standard before using irrigation. The flow diagram below shows grey water treatment for reuse in house hold.

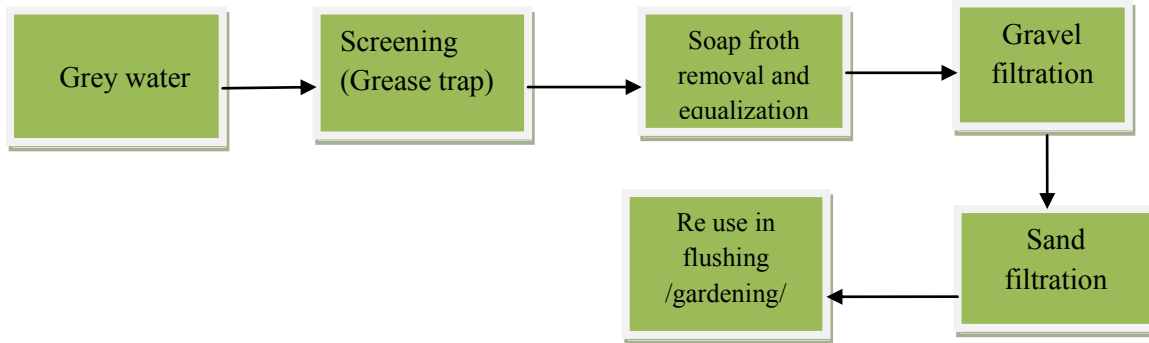

Figure 4 : Grey Water Treatment for Reuse in House Hold

Assessment of grey water recycling Memon A. et al. (2007) was used in identifying four grey water recycling technologies. The technologies Memon A. et al. (2007) investigated include reed beds, membrane bioreactors (MBR); membrane chemical reactors (MCR) and an innovative green roof water recycling system (GROW). The choice of grey water recycling technology is dependent on planned site, available space, user needs, and investment and maintenance cost, applicability in which the technology is accessible in the market and effluent reuse factors.

Characteristics of specific treatment systems that should be considered and compared during the **technology selection** process includes effectiveness of the treatment technology, all costs over time, reliability, longevity, ease or difficulty of management, space required, and ability of the technology to handle changes in amount of flow and waste water quality (Simms, 2006).

The major portion of waste water consists of grey water. Simple onsite processes for this larger portion of grey water can be practical and economic and can reduce the pressure on centralized system. Because large portion of grey water is not needed to be transported to the treatment plant due to the implementation of decentralized process. **Dual pipe** system can be used to split one significant portion of grey water and to store them separately for treatment. The remaining black water can be treated centrally. So, actually the proposed plan is to introduce decentralized recycling system for the grey water can be implemented at house hold or cluster level, so the recycling systems are needed to be healthy and simple to operate (Musfique, 2012).

Sand filters are one of the proposed waste water treatments and reuse strategy. It is the commonly used media but gravel, crushed glasses, mineral investigation; anthracite /hard coal/ and bottom ash from power plants also has been used. Sand filters can be used for a wide range of applications, including single family residences, large commercial establishments and small communities (Musfique, 2012).

According to Khume (2014) stated from EPA (1997) total waste water contains about 99.9 % of water and the rest 0.1% is total solids. Total solids are the amount of solid residue remains and it is the mixture of suspended solids, dissolved solids and the colloidal solids. The following figure shows the composition of municipal waste water.

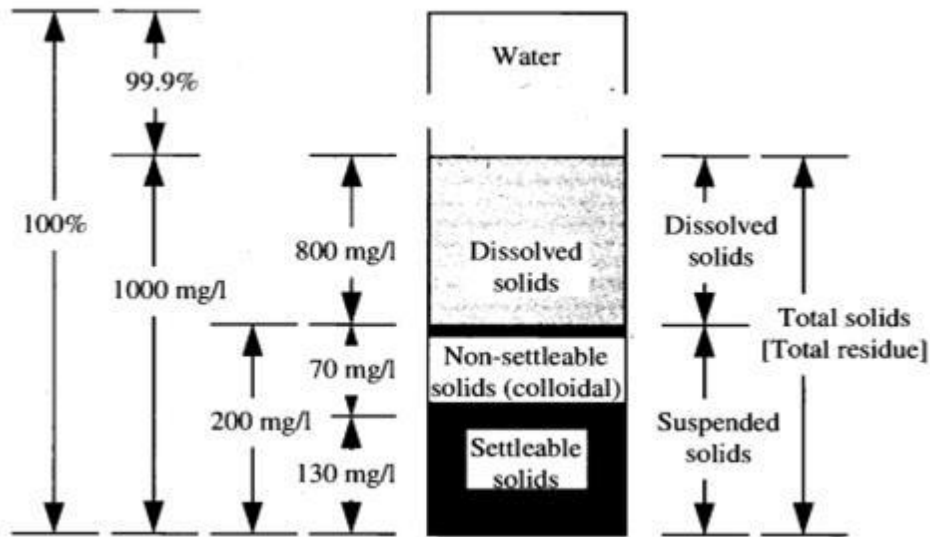

Figure 5: Typical Composition of Waste Water
(EPA, 1997)

2.5 System Description of Grey Water Treatment Technologies

Grey water treatment plant design is one of the difficult aspects of engineering and recycling grey water. There are different types of grey water treatment plants based on the quality and quantity of the liquid waste to be treated. In addition to the quality and quantity of the grey water to be treated, the selection of treatment process depends on the required land space for construction, the protection of the environment and the public health, avoid pollution of surface and ground water, and protect natural flora and fauna and the relative investment, personnel skilled required, familiarity of the technology in the city and running costs of the various treatment technologies for reusing of grey water. The most commonly grey water treatment technologies that are found from different literature are listed and described as follows;

- Conventional activated sludge system (CAS)
- Extended aeration activated sludge system (EAAS)
- Sequential batch reactor system (SBR)
- Trickling Filters (TF)
- Rotating biological contactor system (RBC)
- Stabilization ponds
- Moving bed biological reactor (MBBR)
- Membrane bio-reactors (MBR)

2.5.1 Conventional Activated Sludge (CAS) System System Description

The conventional activated sludge system is a biological treatment process that use bacteria suspended in liquid in order to remove organic matter, ammonia and nitrogen from the waste water.

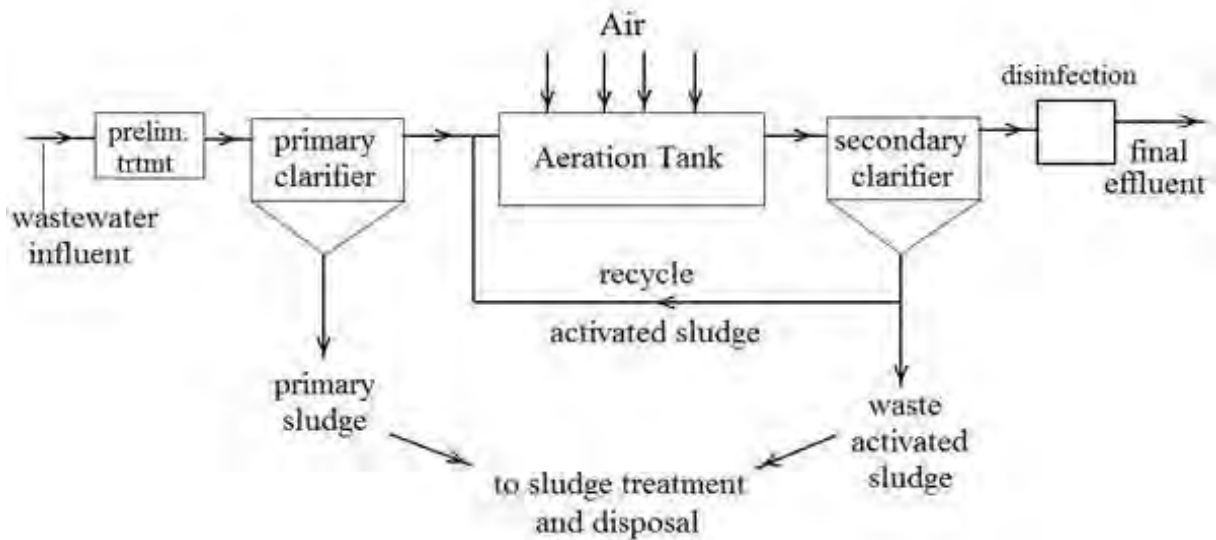

Figure 6: Conventional Activated Sludge Flow Chart
(Melvin, 2014)

A typical CAS system consists of the following units:

1. Preliminary treatment units: This unit includes the following sub units:
 - i. Screening: This unit is used for blocking coarse materials from entering the treatment plant, with the risk of destroying and blocking the downstream equipment (pumps, piping etc.). In a typical CAS system the screens have openings ranging from 50 mm down to 6 mm, in order to prevent coarse materials but in the same time not to blocking easily, requiring more frequent cleaning.
 - ii. Grit and oil removal unit: this unit is used to remove allow the lighter organic materials to flow but removes the heavier inert materials (e.g. sand, gravel etc).from the waste water.
2. Primary settling: This unit is designed to remove suspended solids from the wastewater inflow in order to reduce the volumes and the aeration requirements of the downstream bioreactors.
3. Bioreactors: the biological treatment process takes place in this unit with the aid of bacteria in suspension in the mixed liquid, which removes the organic matter from the waste water. Where oxygen is added mechanically and mixing is provided the reactions takes place in a tank known as biological tank or bioreactor. Through this process „biological flocks“ are generated.
4. Secondary (final) settling: The effluent from the bioreactors is led to the final sedimentation tanks, where the treated liquid is separated from the biomass by gravity. The biomass sludge settles to the bottom of the tank while the supernatant treated effluent overflows to the water receptor. If it is required the final effluent goes through disinfection treatment prior to its discharge to the receptor.
5. Sludge treatment unit: The sludge treatment is necessary for producing a final sludge quality that can be either disposed in landfills or to be reused in various applications (e.g. irrigation, land application rehabilitation of mines etc.) (Gamsby, 2012).

Advantages and disadvantages

The advantages of the CAS system include the following

1. Well proven process
2. Open source technology and requires less personal skills to operate and maintain a plant than other processes(e.g. MBR,SBR)
3. Relatively low odour nuisance:
4. Relatively good resistance to variations in the flows and loads
5. Potential energy recovery (biogas utilization from anaerobic sludge digestion)

Disadvantages of the CAS system include the following:

1. Land requirements for the facilities of the CAS system construction which however is much less than the land required by ponds and EAAS.
2. CAS system requires more skilled operation than other processes (i.e. Ponds).
3. CAS system requires a high proportion of electro-mechanical plant and therefore has relatively high construction and maintenance costs.
4. Operational concern regarding the wastewater biological solids separation: The most common operational problem in activated sludge processes is related to difficulties of separating biomass from the treated effluent in the final clarifiers (due to sludge bulking).
5. High sludge production (Jafrudeen, 2012)

2.5.2 Extended aeration activated sludge system (EAAS)

System description

The EAAS system is a similar biological treatment process to the CAS with a main difference in the sludge retention time (SRT) in the bioreactors. Moreover, the EAAS systems do not have primary sedimentation units.

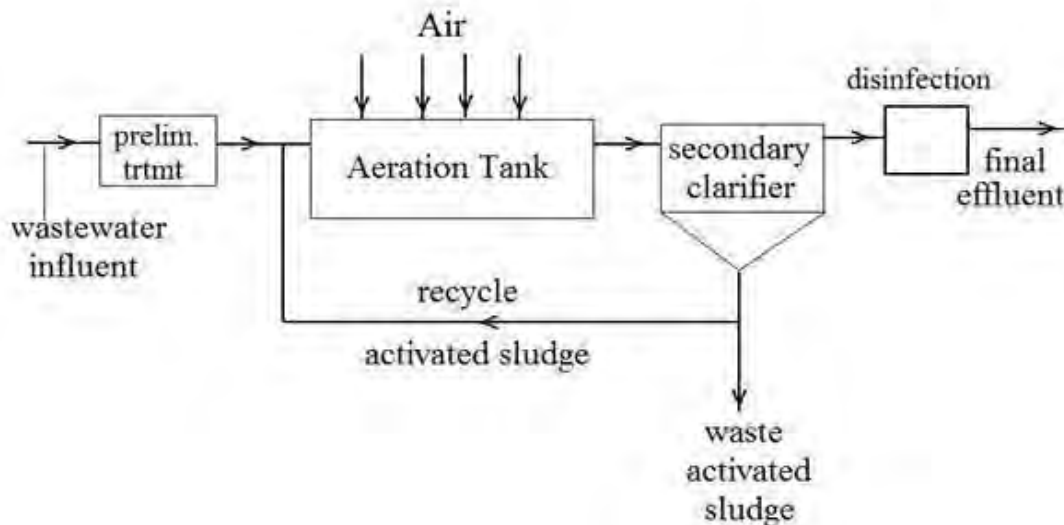

Figure 7: Extended Aeration Activated Sludge System
(Gamsby, 2012)

A typical EAAS system consists of the following units:

1. Preliminary treatment unit with same requirements as the CAS system
2. Bioreactors: the bioreactors in the EAAS system perform the same processes as in the CAS system (carbonation, nitrification and de-nitrification /phosphorus removal). However, due to the increased organic load (due to the absence of the primary settling tanks) there is need for higher sludge retention time in the bioreactors. The longer SRTs of the EAAS system require in turn much larger bioreactors volumes and much higher aeration to achieve the quality of effluent achieved by the CAS systems. Moreover, due to the longer SRT the sludge produced is less than in CAS systems and stabilized, thus further treatment with digestion is not required. However, the sludge from the EAAS system more wet and is more difficult to dewater.
3. Secondary (final) setting: The second settling tanks of the EAAS system are the same as the secondary tanks of the CAS system.
4. Sludge treatment unit: The sludge treatment unit is necessary for producing a final sludge quality that can either disposed in landfills or be reused in various applications (e.g. agriculture, land application, rehabilitation of mines etc.) (Gamsby, 2012)

Advantages and disadvantages

The advantages of the EAAS system include the following

1. Well proven process
2. Simple open source technology: this treatment technology requires less personal skills to operate and maintain a plant than other processes (e.g. MBR, SBR).
3. Low odour nuisance:
4. Good resistance to variations in the flows and load.
5. Small volumes of sludge (produced biomass) that need final disposal
6. Likely low capital costs; lower mechanical and electrical content than CAS system for achieving the limits required.

Disadvantages regarding the EAAS treatment process include the following

1. Large land foot print then the CAS system
2. High electrical operating cost of the secondary treatment plant
3. The system has increased risk of facing bulking problems.
4. The process has relatively poor resistance to toxic shocks;
5. The produced sludge is more difficult to dewater.
6. Due to high energy requirement the cost of EAAS system is increased (Jafrudeen, 2012)

2.5.3 Sequential Batch Reactor System (SBR)

System Description

The sequential batch reactor system is practically a CAS system, in which the operations of the bioreactors (carbonation, nitrification and de-nitrification/ phosphorous removal if required) and of the final settling tanks are performed in single tank.

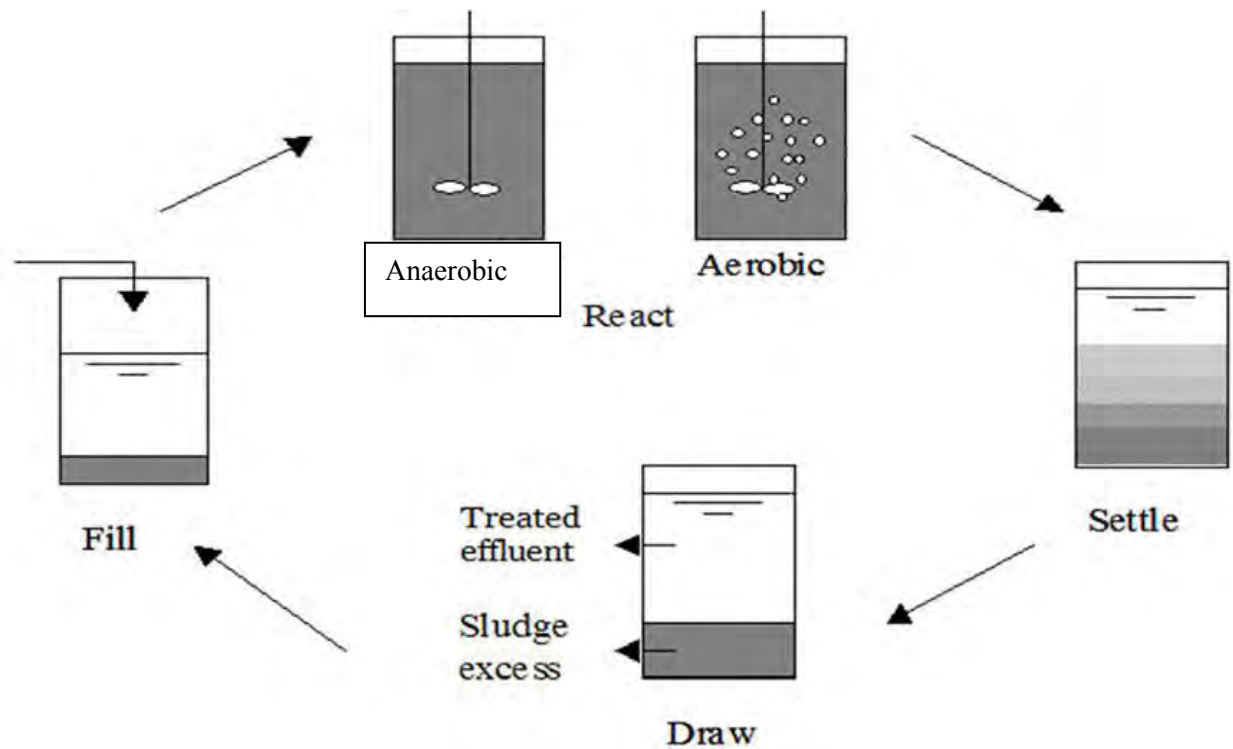

Figure 8: Sequential Batch Reactor System Operation Phases
(Mahvi, 2008)

The SBR system consists of single or multiple reactor tanks that comprises fill, react, settle, draw and idle phases. Depending on the treatment objective the fill phase may be static (no mixing or aeration) and mixed fill (mixing without aeration). Where as in the react phase influent flow is stopped and mixing and aeration continues, in the settling phase mixing and aeration are stopped and settling starts, in the draw (decant) phase clear supernatant is decanted, in the waste sludge phases and idle phases the excess sludge is removed from the tank and the basin is on standby to restart the process respectively (Gamsby, 2012).

Advantages and disadvantages

The advantages of the SBR system include the following

1. Well proven process
2. Open source technology
3. The system requires lower proportion electro-mechanical plant than the CAS system and therefore has likely low construction and maintenance costs.
4. Smaller foot print than CAS system due to the combination of the biological and clarification functions in one tank.
5. Same level of resistance to variations in the flows and loads as the biomass can adapt to these loads up to a degree.
6. Same level of resistance to variations in the flows and loads as the biomass can adapt to these loads up a degree.

7. Potential energy recovery (biogas utilization from anaerobic sludge digestion) which may increase the cost efficiency of the process

Disadvantages of the SBR system include the following:

1. The process is complex and requires very skilled personnel for its operation and maintenance (more skilled than CAS and EAAS systems) and has relatively poor resistance to toxic shocks:
2. Difficulty in decanting the treated effluent without drifting solids from the sludge blanket.
3. Same problems as CAS system as regards with the sludge settling issues (bulking)
4. High sludge production (EPA, 1999).

2.5.4 Trickling Filters (TF)

System Description

Trickling filter is another system for biological treatment of wastewater. In these plants the bacteria are not suspended in liquid, as in activated sludge plants, but the microorganisms are attached on a medium fixed in the bioreactors. As the waste drips through the medium the organic matter is absorbed by the bacteria and utilized as food (carbonation). The slime layer of bacteria is about 0.1 to 0.2mm thick.

As the waste is poured evenly at the top of the medium with the use of rotary distributor, it flows over the medium (rocks, slag or plastic elements) and microorganisms already present attach to the medium and form the slime layer. As the layer gets thicker oxygen can no longer penetrate the medium phase, anaerobic bacteria start to grow and they lose the capability to stick to the medium. So from time to time the sloughing phenomenon takes place where a large amount of slime falls off the filter. These solids are collected along with the treated water in a downstream settling tank, in which they are separated by settling as in the case of CAS and EAAS systems.

Due to the fact that biomass attached in the medium is more concentrated than in activated sludge, the organic load rate in trickling filter is much higher than in CAS systems and accordingly the required volumes of the bioreactors are significantly smaller than CAS system. Moreover, the nature of the sludge produced from trickling filters has better settling features, because the attached growth biomass does not help the development of filamentous bacteria, so the bulking problems of the activated sludge systems does not occur in attached growth systems.

A TF system requires preliminary and primary treatment units (as in CAS systems) which are necessary in order to minimize the potential of clogging of the filter. In fact the screening requirements for the TF system may need to go lower than the 6 mm screen opening of the CAS system, to openings down to 2-3mm, which may increase the cost of screening and the cleaning frequency of the screens.

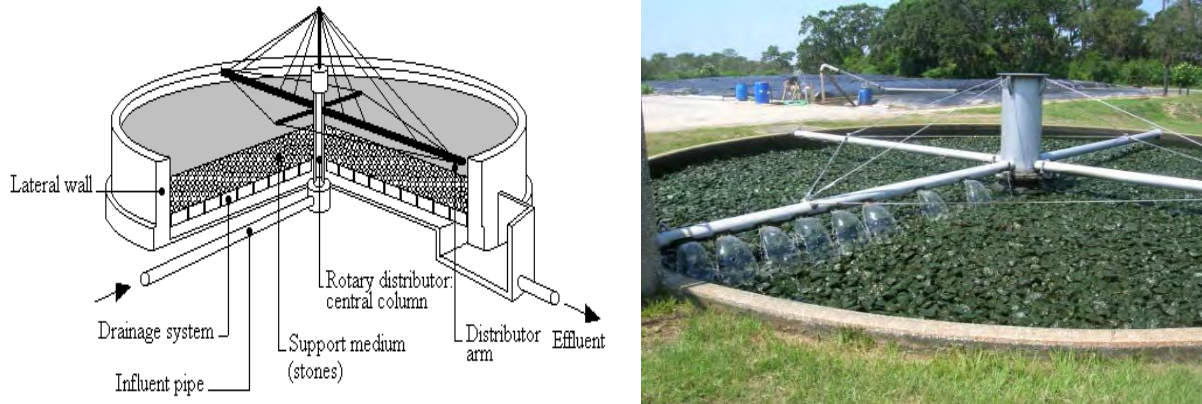

Figure 9: Typical Configuration and Main Parts of a Trickling Filter with Rocks Medium (Marcos, 2012)

Moreover, in order to increase treatment efficiency of the TF, treated effluent from the final clarifiers is re-circulated back to the top of the TF. No sludge recirculation is required in this case.

The sludge from primary settling and from the secondary clarifiers requires sludge treatment as in the case of CAS and SBR systems. However, sludge is easier to be dewatered than in the case of the other two systems.

Advantages and disadvantages

The advantages of the TF system are described below;

1. It is a simple and reliable biological process
2. It has low footprint
3. Large areas of land are not required
4. It is efficient in treating high concentration of organic material
5. It can efficiently remove ammonia
6. It is suitable for small to medium sized cities
7. They have excellent resistance from shock loads (flow and quality) and from toxic loads.
8. The operational cost of a trickling filter is much lower compared to activated sludge plants, because the aeration (major part of energy consumption in CAS system) is done by natural flow of the air.
9. They produce less surplus sludge compared to activated sludge plants, which is a characteristic of the attached growth systems.
10. The sludge has better settling characteristics because it is more dense and heavy
11. The level of skill and technical expertise needed to manage and operate such a system is moderate

Disadvantages of the TF treatment process includes the following

1. The efficiency of the TF is not as good and less stable compared to that of the activated sludge systems, so additional treatment needed to meet the required discharge standards;
2. In order to effectively remove ammonia (90%), the organic loading rates should be very low, resulting to volume of the TF comparable to the CAS bioreactors and thus cancelling the small footprint of the bioreactors;
3. The TF is not adequate to provide de-nitrification or phosphorus removal

4. Usually the incoming wastewater cannot be directly feed to the filter making the plant more complex in operation, since primary settling tank and advanced screening (2-3 mm opening) is required to avoid clogging of the medium
5. It has high rate of clogging which lowers the total effective volume and reduces its capacity
6. The necessary flow of air through the filters, for supplying oxygen to the bacteria, is driven by the pressure and temperature difference between the air inside and outside the filters. But at certain periods the meteorological conditions minimize these differences and aeration can become problematic.
7. It has high potential risk for filter and odour problems, due to the aeration problems mentioned above:
8. It has limited flexibility and control in comparison with activated sludge processes;
9. Recirculation of effluent and forced ventilation of the effluent gives some flexibility to the operator to improve operation and effluent quality, make the biomass sloughing continuous and minimize the filter files. But it also increases the operational cost and the complexity of the operation (Marcos, 2012).

2.5.5 Rotating Biological Contactor System (RBC)

System Description

The RBC is another attached growth treatment process principally composed of a complex of multiple plastic discs mounted on a horizontal shaft. The shaft is mounted at right angles to the waste water flow and approximately 40% of the total disc surface is submerged in order to achieve removal of the organic load and nitrification of the ammonia content. As the shaft rotates at a rate of between one and two revolutions per minute, the disc slowly revolves and bacteria grow on the disc plates by adsorbing organic materials from the waste water; these solids settle in the downstream settling tank. As the top 60% of the disc plate area passes through the air, oxygen is absorbed to keep the growths an aerobic state (Steven, 2011).

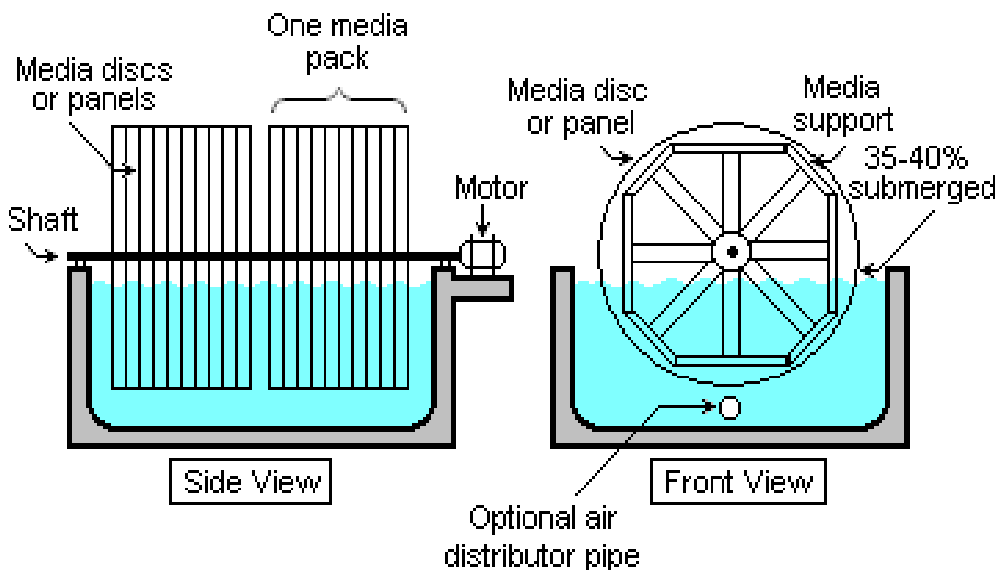

Figure 10: Rotating Disc Arrangement
(Steven, 2011)

The RBC system requires preliminary treatment (screening), de-gritting etc.) at the same levels of CAS systems; however there is no actual need for primary settling ,as EAAS systems, because the disc are not really susceptible to clogging. Accordingly, this increases the bioreactor's footprint (due to the increased incoming load) which however is much smaller than the footprint of CAS and EAAS systems.

The RBC bioreactors can be used also for de-nitrification and phosphorus removal. In these cases the rotating contactors are fully submerged in the wastewater in order to achieve anaerobic and anoxic conditions (with recirculation of mixed liquid from the nitrification bioreactor) (Steven, 2011). In some cases, there is provision for additional aeration in the waste water basin as presented in the figure above.

Advantages and disadvantages

Being an attached growth system RBC has a lot of similar advantages with the TF system as described below;

1. It is an open technology
2. It is a simple and reliable biological process; The plant operators do not require expensive training or skilled qualifications to monitor the system;
3. The operation cost of RBC system is much lower compared to activated sludge plants;
4. Short contact periods are required because of the large active surface ,which means very small footprint compared to activated sludge systems;
5. RBCs are capable of handling a wide range of flows, loads and have high resistance in toxic shocks. It can be applied for de-nitrification and phosphorus removal in order to meet strict discharge standards.
6. It has low sludge production. The sludge has better settling characteristics because it is more dense and heavy and is easier to dewater than in activated systems.
7. It is suitable for small to medium sized cities,
8. No files issues are encountered and odour nuisance is lower than in TF systems.

Disadvantages of the RBC systems include the following

1. Potential failure of mechanical components with the system, such as the shafts, disks and bearings .because of poor design regarding the weight of the attached biomass, or of poor maintenance;
2. Clogging risk is much lower than in TF system, but still remains as a potential. For this reason, primary settling tank may be required, thus making the system more complex (additional settling unit, Sludge treatment);
3. The system is commonly installed in a concrete tank, which present difficulties for plant operators to monitor the system effectively within the tank;
4. A single RBC is usually not capable of completing the breakdown of organic matter required for the effective treatment of wastewater.
5. The shaft bearings and the mechanical drive units require frequent maintenance (Prashant, 2012).

2.5.6 Stabilization Ponds (SPs)

System Description

Waste stabilization ponds (WSPs) are large, manmade water bodies. The ponds are filled with waste water that is then treated by naturally occurring processes. The ponds can be used individually, or linked in a series for improved treatment. There are three types of ponds, (1) anaerobic, (2) facultative and (3) aerobic (maturation), each with different treatment and characteristics.

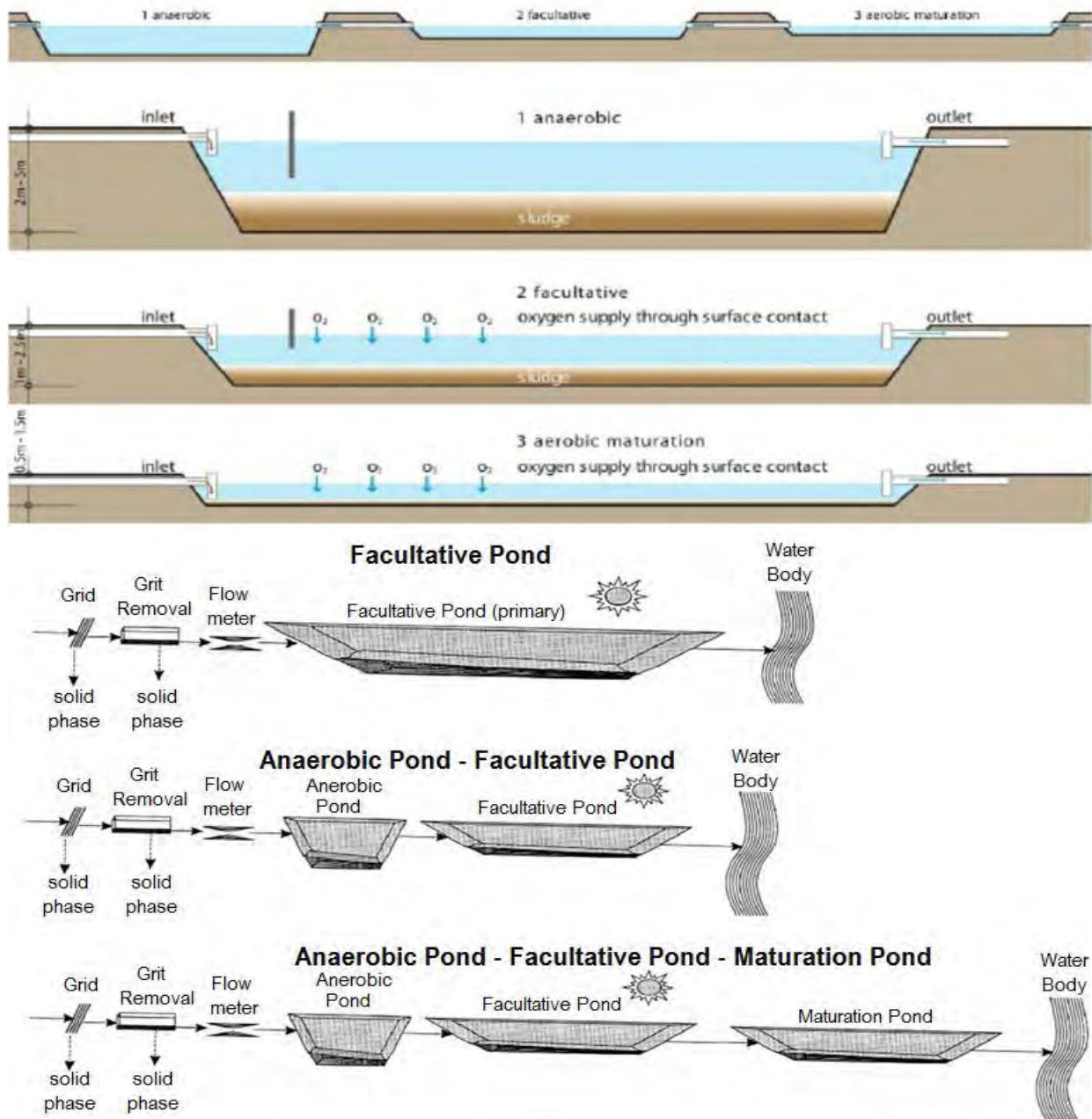

Figure 11: Typical WSPs Configuration Series
(Keller, 2012)

For the most effective treatment, WSP should be linked in a series of three or more, with effluent being transferred from the anaerobic pond to the facultative pond and finally the aerobic pond. The anaerobic pond reduces solids and BOD as a pretreatment stage. The pond is a fairly deep man-made lake where the entire depth of the pond is anaerobic. Anaerobic ponds built to a depth of 2 to 5m. Anaerobic bacteria

convert organic carbon into methane and in the process, remove up to 60% of the BOD. Anaerobic ponds are capable of treating strong waste waters.



Figure 12: Waste Stabilization Ponds
(WOC, 2013)

The effluent from the anaerobic pond is transferred to the facultative pond, where further BOD is removed. A facultative pond is shallower than an anaerobic pond and both aerobic and anaerobic processes occur within the pond. The top layer of the pond receives oxygen from natural diffusion, wind mixing and algae-driven photosynthesis. The lower layer is poor of oxygen and becomes anoxic or anaerobic. Settle able solids accumulate and are digested on the bottom of the pond. The aerobic and anaerobic organisms work together to achieve BOD reductions of up to 75%. The pond is usually constructed to a depth of 1 to 12.5m.

Following the anaerobic and the aerobic facultative ponds can be any number of aerobic (maturation) ponds to achieve a highly polished effluent. An aerobic pond is commonly referred to as a maturation, polishing, or finishing pond because it is usually the last step in a series of ponds and provides the final level of treatment. It is the shallowest of the ponds, usually constructed to a depth between 0.5-1.5m deep to ensure that the sunlight penetrates the full depth for photosynthesis. Because photosynthesis is driven by sunlight, the dissolved oxygen levels are highest during the day and drop off at night. Whereas anaerobic and facultative ponds are designed for BOD removal, maturation ponds are designed for pathogen removal. Dissolved oxygen in the lake is provided by natural wind mixing and by photosynthesis algae that release oxygen in to the water. If used in combination with algae and/or fish harvesting, this type of pond is effective at removing the majority of nitrogen and phosphorus from the effluent (WOC, 2013).

Advantages and disadvantages of WSPs

Advantages of the WWSPs include the following;

1. Well proven process
2. Open source technology
3. Simple operation ; requires very low personnel skills to operate and maintain the facilities
4. Very low operational cost due to the negligible energy consumption, the lack of chemicals usage and the minimal maintenance and personal skills requirements;
5. Good resistance to variations in the flows and load, due to the big volumes of the lagoons;
6. Reduction of organic load

7. Very small quantities of sludge (produced biomass) that need final disposal
8. High reduction of pathogens.

Disadvantages regarding the WSPs include the following:

1. Suspended solids efficiency is rather low
2. Vast land footprints; especially compared to mechanical systems as CAS, EAAS etc.
3. Settled sludge and inert material require periodic removal. Furthermore, the sludge needs further treatment as in the CAS system;
4. Sludge accumulation will be higher in cold climates due to reduced microbial activity;
5. Mosquito's and similar insect vectors can be a problem if emergent vegetation is not controlled
6. Strong odors are frequent and are significant during spring and fall lagoon turnovers (WDNR, 2013), WDNR = Wisconsin Department of Natural Resources.

2.5.7 Moving Bed Biological Reactor (MBBR) System

System Description

Moving media bio-reactors are systems that combine two existing technologies, namely the activated sludge systems (e.g. CAS, EAAS, SBR etc). The configuration of a MBBR system is similar to the CAS systems (anoxic/aeration tanks and final clarifiers), but in MBBR systems biomass grows on specific plastic media (bio carriers), instead of developing as flocs, which in turn eliminates the need for sludge recirculation. Moreover, due to the development of the biomass on the carriers in the tanks, the pollution loading rates can be much for the same level of treatment, than in a CAS system, thus allowing for much smaller volumes of anoxic/aeration tanks (smaller footprint of the treatment plant). A flow scheme of the MBBR configuration for carbon and nitrogen removal is given below

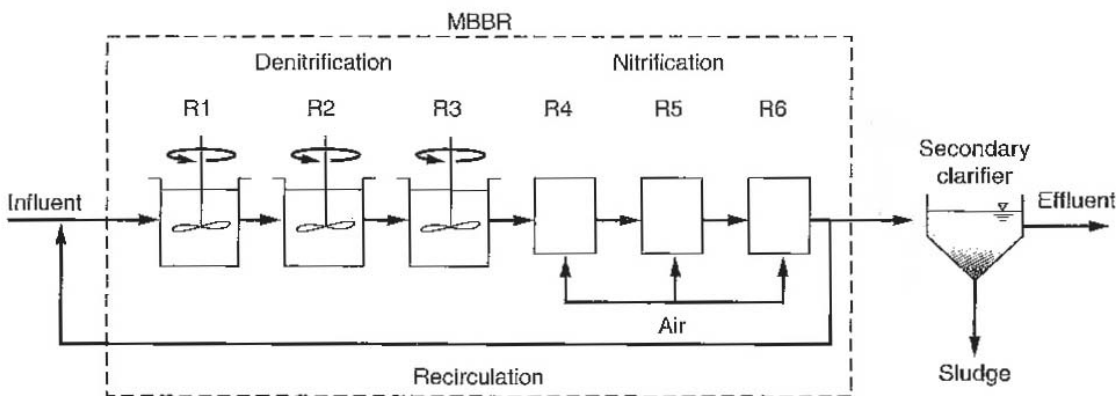

Figure 13: Typical MBBR Treatment Scheme for Pre-denitrification and Carbonation/nitrification (Igarash et al, 1999)

The MBBR system requires the level of preliminary and primary treatment applied in CAS systems. The biomass in the bioreactor tanks is attached to specially developed carriers (“bio-carriers”). The bio-carriers are plastic media lighter than water, with certain configuration that allows biomass to grow on their free surface. These carriers are retained in the bioreactors by the use of sieves that allow wastewater to flow through to the downstream settling tanks (Kermani et al, 2008)



Figure 14: MBBR Bio-Carrier and Retaining Sieves
(Daniel, 2014)

The treated wastewater is then flows to the settling tanks where it is separated from the sloughed biomass by gravity.

Advantages and disadvantages

The advantages of the MBBR system include the following:

1. Significantly small footprint of the anoxic/aeration tanks compared to the CAS system.
2. Excellent tolerance to toxic shocks and to variations in flow and loads
3. The MBBR technology is considered an open technology.
4. Eliminates sludge bulking (main operational problem of activated sludge systems)
5. It has low sludge production
6. Potential energy recovery (biogas utilization from anaerobic sludge digestion)
7. It can self-regulate the biomass, which means that few operational adjustments are required along with the equipment maintenance.

Disadvantages of the MBBR treatment process include the following:

1. MBBR has additional cost of the media
2. The aeration requirements are a bit higher than CAS systems but much lower than EAAS systems
3. Small potential for fouling of the media and of the media separation screens;
4. It can be difficult to maintain diffusers in the aeration tanks (Borkar, 2013)

2.5.8 Membrane Biological Reactor (MBR) System **System Description**

Membrane Bio-reactors systems is an evolution of the CAS system using state of the art technology for the separation of biomass from the treated effluent. The configuration of a MBR system is similar to the CAS systems (anaerobic/anoxic/aeration tanks), but in the MBR system the separation of the solids from the treated effluent is not achieved by gravity in the settling tanks but by filtration with the use of micro-porous membranes that retain the biomass and allow treated effluent to pass through.

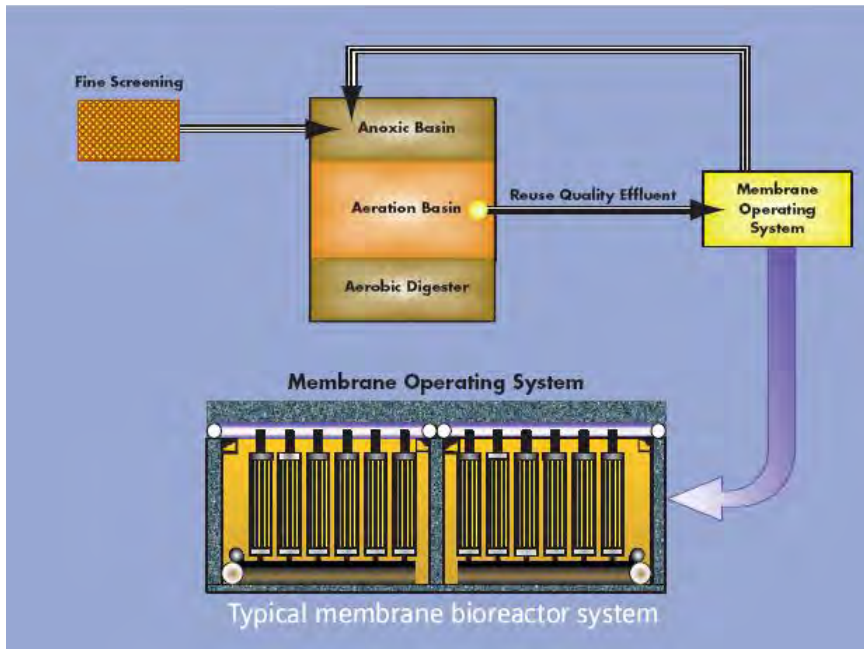

Figure 15: Membrane Configuration of MBR
(USEPA, 2007)

The MBR system requires the level of preliminary and primary treatment applied in CAS systems. It also requires additional micro-screening (0.5-2mm depending on the type of the membranes) upstream of the bioreactors in order to protect the membranes from clogging and from damage from coarse objects.

The membranes are of three types in terms of their architecture, namely the hollow fiber, the flat sheet and the wound type. Also, according to the level of filtration membranes are categorized as Micro-filtration (MF, with pore size 0.1-10 μ m) and as Ultra-Filtration (UF, with pore size 0.001-0.1 μ m). The most commonly used membranes in MBR systems are the hollow fiber and the flat sheet UF membranes.

The major problem in the operation of the MBR systems needs a regular cleaning of the membranes is required, with the use of chemicals and backwashing equipment, which increases more the operational cost of the plant.

Advantages and disadvantages

The advantages of the MBR system include the following:

1. Significantly small footprint of the anoxic/aeration tanks. Compared to the CAS system.
2. Very good tolerance to variations in flows and toxic shocks
3. MBR technology is applied in serving small to medium cities
4. Production of very high quality effluent
5. Eliminates sludge bulking issues
6. Potential energy recovery (biogas utilization from anaerobic sludge digestion of the primary sludge)
7. It has low sludge production

Disadvantages of the MBR treatment process include the following

1. The system is locked into a few suppliers
2. Very high capital cost due to the high cost of the membranes

3. High membrane replacement cost
4. Uncertainty on membrane life
5. Potential for fouling of the membranes
6. Need for very high level of operators skill and monitoring
7. High energy cost for aeration
8. High chemicals consumption for the cleaning and maintenance of the membranes
9. Need for ultra-fine pre-screening required (down to 0.8mm screening for certain membranes) (Elberti, 2012)

2.6 Consumer Water Demand Management with Social Awareness and Education

The effectiveness and rate of uptake of water efficiency measures requires consumers – residential, industrial and commercial – to be aware of the options available, how they should be used or incorporated into existing systems and their performance specifications. Significant efficiency gains can be made if consumers are merely made aware of how much water they use for particular activities and how this water use might be curbed through changes in practice. Education and community awareness are essential elements of water efficiency campaigns in time of scarcity, but even when water supplies are secure it would seem incumbent on utilities to provide advice on water efficiency so that consumers can make informed choices about the water they use. As a result of the education and awareness-raising measures employed to curb demand in areas in which water has been and may continue to be water short, Australians are among the most water-aware of the world’s citizens. This water-awareness has served the country well, and will continue to do so if reinforced delivery of cost-effective water services will be achieved more readily if the community is provided with information sufficient to ensure it does not lose its water literacy over time. Education does not end at the point at which consumers are informed of the options available. Often householders and the managers of commercial premises are unaware of the impacts of their approaches to water management, or how systems or water efficient appliances should be operated to produce maximum benefit. For example, customers may use potable water instead of recycled for outdoor water use in areas with dual reticulation systems. Such behavior can increase system costs as peak demand is transferred from the recycled system to the potable system, unnecessarily requiring more water to be supplied through the potable system, affecting pumping, storage and transport costs Australia Water Association (AWA) strongly urges that comprehensive information be provided to consumers to enable them to make effective choices and to use systems appropriately.

There is a strong argument for more consistent messages to be delivered by utilities operating in different jurisdictions and for exchange of information between utilities about the campaigns and collateral that have been most effective. AWA applauds efforts by its sister organization, the Water Services Association of Australia (WSAA) which represents the major water utilities, to facilitate exchange of information and promote consistency in messages to the community. Australians are among the most water –aware of the world’s citizens. This water -awareness has served the country well, and will continue to do so if reinforced (AWA, 2012).

Public awareness campaigns, should be made as this research concludes with strong establishment of WDM, along with following urgent related activities such as awareness and promotion ,education and

training and the formulation and application of implementation incentives to influence the demand for water. The awareness should be a regional awareness, concentrated on women, through schools and universities, continuous follow up and the feed back of each campaign recorded for the benefit from it and study its effect on consumer's behavior, suggest an installation of private water meter for each apartment by waving the application fees and or installation for new customers and suggest of continuous public awareness through mosques, houses, and schools (Tawfik, 2005).

According to Tawfik (2005) in Gaza city concerning consumer participation in lectures, seminars, or workshops concerning water consumption awareness, where about 94% of the sample didn't receive any handouts and about 90% of the sample didn't attend any meeting. Concerning who is performing houses duties as he put from the individual samples, the results showed that the women are the main component of performing houses duties such 87% of house work is done by women and 11% is done by both housewife and husband and 2% other. Regarding the fruits and vegetables that washed in houses, the results showed that the way of washing fruits even though their 66% of the samples individuals acts by washing fruits directly beneath the facets tips. On other hand 34% of the sample individuals wash fruit in to a bucket, and also it's important to mention that approximately 90% of the samples individuals didn't reuse the fruits washing while 10% of the samples individuals reuse the fruit washing. Concerning the existence of problem in internal water network, the results showed that 85% of sample individuals do repair water supplies fast while 15% does not.

Regarding weekly average number of usage of the house shower for each member of a family summer and winter times; the results showed that the average number of weekly bath equals 3 and 6 for summer and winter respectively. Regarding whether shower continuously running during the duration of bath we found that 78% of the samples individuals doesn't close the shower head while taking a shower. While 22% close the shower head. Regarding the type of washing machine in houses 57% of the individual sample a semi-automatic washer's machine, 19% of the individual sample use automatic washer's machine and 24% of the individual sample use a regular automatic washer's machine. Concerning the consumer has their garden in houses and the way of irrigations he found that 51% of the sample individuals have a house garden but 49 % do not have, 63 % some of the samples individuals do irrigations by hose, 15 % some of the samples individuals do irrigations by a bucket also 6% some of the samples individuals do irrigations by a sprinkler and 16% some of the samples individuals do irrigations by other things.

Regarding whether the consumer has private car and the way wash cars, the way of, 51% of the samples individuals don't have cars and 49% they have cars, the way of washing cars 62% of the samples individuals use a hose while washing cars, and 38% of them use a bucket (Tawfik, 2005).

2.7 Water Demand Management with Replacement of Toilet Flushing Cistern

Replacing potable water with grey water to flush toilets increases water efficiency in buildings; Spahr (2012) stated from AWWA. Mar. 2012, installing fixtures like low-flow showerheads, faucet aerators, and/or water smart dishwashers, individual residences can experience a reduction of indoor water use up to 35%. Even with these fixture changes, the distribution of water uses typically remains the same. The

highest indoor use is for toilets, which account for approximately 30% of all indoor uses. Furthermore, toilet flushing was one of the most consistent water uses, averaging 5 flushes per capita per day. In order to reduce the amount of water used to flush toilets, a couple options exist. First, a lower tank capacity toilet can be installed. National Energy Policy act of 1995 requires toilets to have lower tank capacities of 1.6 gallon/flush or less. Toilets installed before 1993 have a problem of using higher tank capacity of 4 to 5 gallons/flush, thus a switch to low flow toilets significantly reduces the water footprint of a toilet by as much as 68%. Further reduction can be achieved by changing user behavior, for example, through installation of dual flush toilets. However, installation of water-saving fixtures also is subject to economic factors.

Homes built in or prior to 1995 may contain inefficient toilets. Before the 1950s, toilets were designed to flush with 20 liters, and in the 1980s the new toilets being installed were using only 13 liters. Replacing an inefficient toilet with a low flow model will conserve water (Menigistu, 2010).

2.8 Barrel Plastic Grey Water Treatment Technology

On-site barrel grey water treatment were designed with taking in to consideration of achieving low cost and ease of construction and low operation and maintenance costs and to yield grey water of a quality suitable at least for restricted purposes.

2.8.1 Two-Barrel Plastic Grey Water Treatment System

Two plastic barrels constitute the treatment kit. The two barrels are lined up next to the other and interconnected with 50 mm PVC pipes and the volume of the first and second barrel is 160 and 220 liters respectively and has a large cover, which can be closed tightly. The first barrel or tank is fitted with pipes to allow grease, oil and solids separator and thus acts as a pretreatment or primary treatment chamber, Where the solid matter in the influent grey water settles and the floating components, such as grease and soap foam floats. When the cover is opened, the chamber can be cleared of both floating and settle material. The second barrel or tank acts as a storage tank for primarily grey water. As soon as this barrel is filled, a floating device switches on small water pump which then delivers the water through the drip irrigation network. The two barrel kit was found suitable for small families (AL-BEIRUTI, 2004).

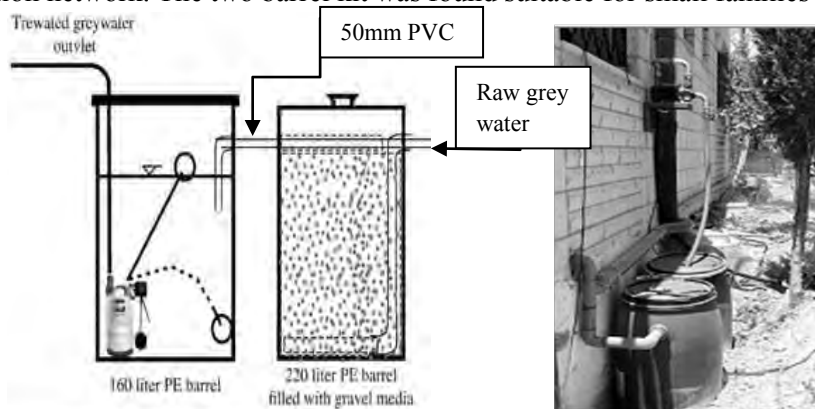

Figure 16: Two-Barrel Treatments Units
(AL-BEIRUTI, 2004)

2.8.2 Four-Barrel Plastic Grey Water Treatment System

The four barrel plastic grey water treatment system is an improvement of the two barrel plastic grey water treatment system. Two tanks each with 220 liter capacity and filled with gravel media that acts as anaerobic filters are inserted between the pretreatment tank and final storage tanks. The four barrels are lined up next to the other and interconnected with 50 mm PVC pipes as shown the figure below.

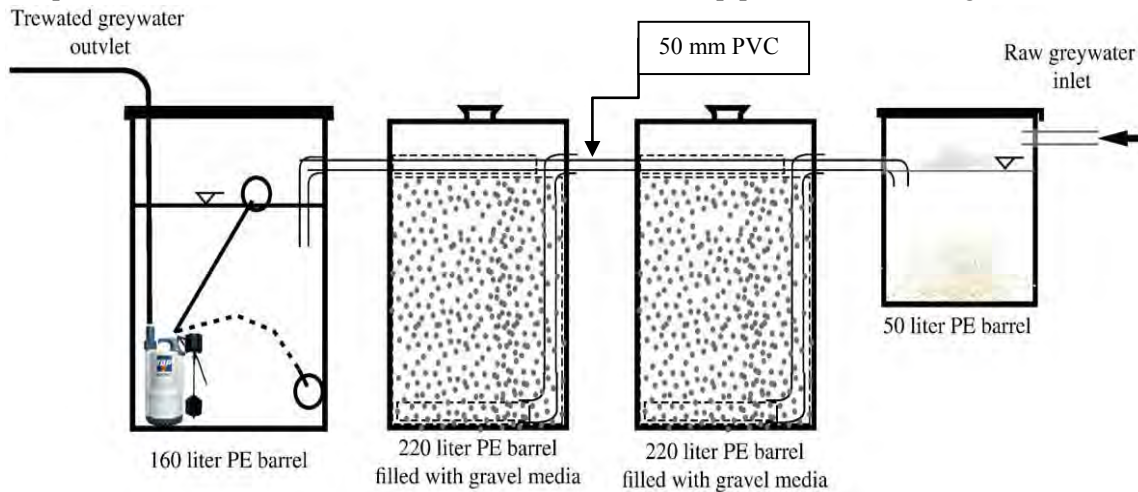

Figure 17: Four-Barrel Treatment Units
(AL-BEIRUTI, 2004)

Once solids and floating materials settle in the first barrel, the relative clear water from the first barrel enters in to the bottom of the second barrel. Next the water from the top of the second barrel enters in to the bottom of the third barrel. This water passes through the gravel lumps (2-3 cm size graded gravel) and from the top of the third barrel is taken in to the fourth. Anaerobic treatment is accomplished in the two middle barrels. Anaerobic bacteria gets established on the stone surface so that when the grey water passes through the stones, the bacteria works on breaking down components of the organic material found in the grey water. The last barrel acts as a storage tank for treated grey water. As soon as this barrel is filled, a floating device switches on a small water pump which then delivers the water through the drip irrigation net work. For an average family home, 20-30 trees (olives, fruits etc) that are planted in the domestic garden can be irrigated.

The retention time of 1 to 2 days in the 4-barrel treatment kit the influent grey water under goes treatment level equivalent to between primary and secondary treatment and meets the world health organization's guidelines for restricted irrigation (AL-BEIRUTI, 2004). The table below shows the effluent quality of treated grey water that can be used to irrigate productive home gardens and the costs to incur for the system (AL-BEIRUTI, 2004).

Table 3: Effluent Quality from 2- Barrel System (Households No 1)

| Sample type | pH | TSS | BOD5 |
|-------------|-----|-----|------|
| 11-6-02 | 6.4 | 39 | 154 |
| 21-7-02 | 6.7 | 69 | 186 |
| 14-8-02 | 7.8 | 2 | 23 |
| 05-9-02 | 8.3 | 57 | 59 |
| 20-10-02 | 6.1 | 94 | 518 |
| 13-12-02 | 8 | 19 | 12 |

Table 4: Effluent Quality from 4- Barrel System (Households No 6)

| Sample type | pH | TSS | BOD5 |
|-------------|-----|-----|------|
| 11-6-02 | 6.8 | 183 | 844 |
| 14-8-02 | 4.7 | 165 | 564 |
| 14-12-02 | 6.3 | 76 | 369 |
| 17-02-03 | 7.4 | 128 | 246 |
| 29-05-03 | 8.2 | 88 | 225 |

Table 5: The Costs to Incur for the System

| System Type | Cost * | System Capacity | Level of Treatment |
|-------------|----------|---------------------|---------------------|
| 2-Barrel | US\$ 230 | 6 persons (330 l/d) | Primary |
| 4-Barrel | US\$ 370 | 6 persons (330 l/d) | Primary & Secondary |

* Cost includes drip irrigation system

The effluent quality of the parameters from 2- barrel and 4- barrel system variation from the table above shows the degree of effectiveness of the treatment was affected by the care of family members with respect to the household prevention of pollution. The regular cleaning of the oil and grease separator /screen/ resulted in high improvement in treatment and reduction the organic and inorganic matters.

CHAPTER 3

3. Methodology

The research **materials** that were used in this study are:

AutoCAD 2007 for allocation and evaluation of condominium houses, system designing of grey water and black water riser diagram, laying out a water distribution network potable water and grey water recycling riser diagram, excel spreadsheet, internet barrel plastic, flexible steel pipe, fittings, gravel and sand.

The research **methodologies** following in this study are:-

Separation of grey and black water was achieved through separate plumbing. The water led through household in separate sewage systems making a separate treatment. For **new** condominium houses this can be easily implemented during the construction phase, but for **old** /existing/ condominium houses where a combined system is in use separation can be difficult since it requires big parts of the old plumbing to be reconstructed. To study the research the following methodology uses for old and new condominium houses.

Data collection for old and new condominium houses; collecting row data for old /existing/ condominium houses starting from the beginning 1996 E.C up to now from Addis Ababa housing construction project office and data collection from consumers to provide information on socio –cultural aspects which are important as they will determine acceptance of a system and the way it is used for a positive public opinion is the key to success for a reuse system on their current practice. So the willingness to implement such measures was assessed. Data from consumer was collected by the method of survey. The reason for this selection was; surveys can give information about the general population by examining only a small sample of it. Results obtained from a survey can be very accurate, valid, well designed and administered. Where as in new condominium houses:

- ☞ Row data was collected from Addis Ababa housing construction project office in the future planned construction condominium houses up to 2020 E.C
- ☞ Architectural typology design of Jemo Gara condominium houses from Addis Ababa housing construction project office.
- ☞ Data collection for water demand information and raw data (water consumption, production and other related data and information) from Addis Ababa water and sewerage authority (AAWSA).
 - The number of people that occupy in condominium houses
 - The water usage , the amount of grey water produced and the amount of grey water produced that will be unused per house hold
- ☞ Total population of AA from central statistical agency.

In the following sections the development of the methodology for each data collection method is described.

Survey

The questionnaire for the survey was designed and several issues were considered in order to produce a well designed questionnaire to assist in getting the correct information.

Length of the questionnaire

The length of the questionnaire was designed in one page in length. The reasons for this are that surveyed users should not be intimidated by the view of a long questionnaire. People are busy and not always willing to appoint more than 10 /ten/ minutes for answering a questioner. The response then would be low and it would be possible that a low amount of questionnaires would be answered and results would not be valid.

Layout

The layout and presentation of the questionnaire was designed in a way that it is easy to answer and friendly to the user. Issues like size of font size and the answering way was considered.

Questionnaire

The purpose of the questionnaire was to provide the necessary data for the research in this research a closed ended questionnaire was used in old condominium houses where as in new condominium houses an open ended questionnaire was used . The reason for the selection of closed ended and open ended questionnaire is to short cut a disadvantage of a survey is the possible bias and is to get more information from professional engineers and managers from old condominium houses and new condominium houses respectively.

Language

The language used to express the questions needed to be simple and concise. Questions translated from English language to Amharic language people could answer the questionnaire easily and would not misunderstand any of the questions. No matter how much effort is put in designing a questionnaire there is always the possibility that some questions are not clear or that it is not easy to be answered. For this reason a questionnaire will be designed for administering some of the questionnaires and collecting comments from the respondents and the final questionnaire had to be designed.

Sampling

Sampling is very important for getting accurate results by questionnaire surveys. Characteristics of the population that affect a research like the one in this report would be, sex, age, education, income and whether the respondent is the water bill payer or not. Ideally the above characteristics of the general population should be retrieving from records and then the respondents should be selected in such a way that the sample is representative of the general population.

Mickey Leland and Jemo Gara condominium houses selected based on stratified random sampling. Simple random sampling is taken from the residential of old condominium houses, AAWSA managers and AAHCPO consultant engineers. As part of a base line study, from old condominium housing 232 households were taken for questionnaire surveys. Ideally sampling 29% of the total household was the goal in order to get representative data for the population in the study area, but this is not possible due to financial limitations. Whereas for new condominium houses from AAWSA I have taken four managers randomly and from AAHCPO new condominium housing construction consultant engineers I have taken a total of seven professionals.

Data handling

The data from the answered questionnaires were manually transferred to an answer sheet or excel spreadsheet.

Piloting grey water treatment technology for old condominium houses

For old condominium houses a barrel plastic grey water treatment technology can be used for each house hold manually. Barrel plastic grey water treatment technology can be easily reused for toilet flushing, floor washing, outdoor plant, car washing, lawns /area of grass, e.g. schools, athletics fields and green areas/, Irrigation of gardens /flower/, machine washing /cloth washing/ and fire protection. The selection criteria of barrel plastic grey water treatment technology was selected from literature review in Jordan as shown in the figure 16 and 17 above and it is suitable for old condominium houses since barrel plastic grey water treatment technology has important on several factors listed below.

Available space

Space requirements as a selection criteria are in the process of assessing the suitability of sites for construction grey water treatment technology. A barrel plastic type grey water treatment technology is an on-site system which is used for low income households to reuse treated grey water and it is a method of technology which is the grey water treatment takes place at the point or nearest of grey water production like within individual houses without transportation for using treated grey water for different purposes. The approximate size required for the installation of this technology is 0.25m² land required inside homes, which is very small land required each house hold can be install this technology.

Plan or design

Barrel plastic grey water treatment technology can not be a need of professional engineer for designing. It can be simply designed and installed by unskilled man powers.

Construction procedure

The construction of barrel plastic grey water treatment technology is first drill the first barrel in one side and the cover at the top, and drill the second barrel in two sides at the bottom and install the two barrels consecutively and connect these two barrels with flexible steel pipe. During this in the first barrel use sieve material which is used as a screener with 1-2mm size and place the filter material sand and gravel at the bottom of the first barrel. After this treated grey water is generated or collected in to the second barrel considering the community easily use for flushing toilets, floor washing, outdoor plant and Irrigation of gardens with home owners, barrel greywater treatment technology users processes automatically self maintaining without consulting plumber consultants.

Public perception

A major difficulty for implementation of grey water treatment is public perception that is people thinking grey water recycling is unsafe or unhealthy. However using a manually barrel plastic grey water treatment technology the public acceptance of grey water reuse were assessed in the socio technical issues.

Lab Test

Collecting 25-31 house hold samples from residences of mass condominium houses. We collect grey water about one litter from each household in order to approve the quality of barrel plastic grey water treatment technology. This is done in laboratory water tests to know and to compare the influent and effluent grey water quality of the parameters BOD₅, TS, TSS, TDS, TVS, COD, DO in mg/l and PH values taking influent samples from the mixing 25-31 household samples and one sample from effluent. The value of PH and DO is directly measured where as the following formulas can be applied to calculate the values of TS, TSS, TDS, TVS and COD.

Total solids (TS)

$$\text{mg total solids /L} = \frac{(A - B) \times 1000}{\text{mL sample}} \quad (\text{TAHD, 1999}), \text{TAHD} = \text{Technical Assistance Hydrology Project}$$

Where:

A = weight of dish + residue, mg

B = weight of dish, mg

Total suspended solid (TSS)

$$\text{mg total solids /L} = \frac{(A - B) \times 1000}{\text{mL sample}} \quad (\text{TAHD, 1999})$$

Where:

A = weight of filter + dried residue, mg

B = weight of filter, mg

Total dissolved solids (TDS)

$$\text{TDS} = \text{TS} - \text{TSS} \quad (\text{TAHD, 1999})$$

Total volatile solid (TVS)

$$\text{Total Volatile Suspended Solids mg/L} = \frac{(B - C) \times 1000 \text{ mg/g} \quad (\text{Schumacher, 1989})}{\text{Sample volume}}$$

Where;

B = Weight of residues + dish, mg

C = weight ignition, mg.

Biological oxygen demand (BOD₅)

$$\text{BOD}_5, \text{ mg/L} = \frac{(\text{DO}_i - \text{DO}_f)}{P} \quad (\text{Delzer, 2003})$$

Where;

DO_i = DO of diluted sample immediately after preparation, mg/LDO_f = DO of diluted sample immediately after 5 days incubation at 20°C, mg/L

P = decimal volumetric fraction of sample used

$$\text{or } P = \frac{\text{Volume of sample}}{\text{Volume of bottle}}$$

Chemical oxygen demand (COD)

Calculation

$$\text{COD as mg O}_2/\text{L} = \frac{(A - B) \times M \times 8000}{\text{mL sample}} \quad (\text{IITD, 2013})$$

Where:

A = mL FAS used for blank

B = mL FAS used for sample

M = molarities of FAS, FAS= Standard ferrous ammonium sulfate titrant

8000 = milli-equivalent weight of oxygen X 1000 mL/L.

$$\text{Molarity (M) of FAS solution} = \frac{\text{Volume 1.5 ml K}_2\text{Cr}_2\text{O}_7 \text{ solution titrated, mL}}{\text{Volume FAS used in titration, mL}} \times 0.1$$

Grey water treatment technology selection for new condominium houses

Selection of decentralized grey water treatment technology was selected and systematic design of grey water recycling in the selected new condominium houses incorporated. The methods chosen in this thesis for grey water treatment considers different types of decentralized grey water treatment technologies that consists of a variety of approaches based on the quality and quantity of the liquid waste to be treated, the required land space required for construction, the protection of the environment and the public health (avoid pollution of surface and ground water, and protect natural flora and fauna), the relative investment and running cost, personnel skilled required and familiarity of the technologies for reusing of grey water for mass condominium houses should be assessed as a demonstrators for future plan construction condominium houses. These comparative approaches will be evaluated and compared based on literature review of selected decentralized grey water treatment technology and from the interview results that was addressed from professional engineers and AAWSA managers in the case of Mickey Leland condominium houses socio-technical issues.

3.1 Study Area

3.1.1 Geographical Location and Area

Condominium houses located inside the city map of Addis Ababa, Addis Ababa has been a center for economic, social and political affairs /activities of the country for over 100 years. Addis Ababa at the moment covers 540 square kilometer land area as obtained from city map. The city is located at the center of the country, at an altitude ranging from 2,100 meters above sea level at Akaki in the south to 3,000 meters above sea level at Entoto hill in the north (PSASP, 2013).

3.1.2 Climate of Addis Ababa City

The city has a complex mix of highland climate zones with average temperature differences of up to 12.2 °c depending on mild and warm temperature climate; and the monthly rain fall is listed in the table below.

| Month | Jan | Feb | Mar | Apr | May | Jun | Jul | Aug | Sep | Oct | Nov | Dec |
|--------------------|------|-----|------|------|-----|-------|-------|-----|-------|------|-----|------|
| Rainfall in mm | 16.5 | 36 | 68.2 | 88.8 | 76 | 123.5 | 259.4 | 278 | 174.1 | 41.1 | 8.3 | 10.2 |
| Average rainy days | 5 | 3 | 7 | 10 | 10 | 20 | 27 | 26 | 18 | 4 | 1 | 1 |

(Source: socio-economic profile of Addis Ababa; policy study and analysis sub process, 2004 E.C)

The lowest and highest annual average temperatures recorded about 10°C and 25°C respectively. Average annual rain fall is around 1250mm. Since it is establishment, the population is increasing at alarming rate. According to the central statistical agency (CSA) 1984 ,1994 and 2007 G.C population census, this gives a population of 1.423 million, 2.112 million and 2.739 million in 1984,1994 and 2007 G.C respectively and average annual growth rate of 2.1% (CSA , 2013). The city is administratively divided in to ten sub-cities and 100 kebeles (Menigisitu, 2010).

Addis Ababa Housing Construction Project Office (AAHCPO) is a public authority and organized in 19 branch offices. Out of 19 branch offices ten of them are sub cities namely: Nifas silik, Akaki, Gulele, Bole , Kolife, Yeka, Lideta, Kirikos, Addis ketema and Arada HCPO and eight branch project offices namely: project 11, project 12, project 13, project 14, project 15, project 16, project 17, project 18 and 1 Agirostone HCPO.

In this research Mickey Leland and Jemo Gara Condominium houses from old /existing/ and new condominium houses are selected respectively. Mickey Leland and Jemo Gara Condominium houses are located inside the city map of Addis Ababa located Kolfe Keranio sub-city.

Mickey Leland Condominium houses has 39.86 ha land coverage's, 27 communal, 628 studio, 698 one bed room, 2365 two bed room, 560 three bed room, 360 commercial houses , 123 blocks and a total of 4638 houses. Whereas Jemo Gara condominium houses are located on the west tip of the city in Oromya sharing property line with Kolfe Keranio sub-city and it has 32.3 ha land coverage's, 35 communal, 1044 one bed room, 563 two bed room, 570 three bed room, 1460 commercial houses , 46 blocks and a total of 2404 houses. The location map of the study area is shown in figure 19 and figure 20 below.

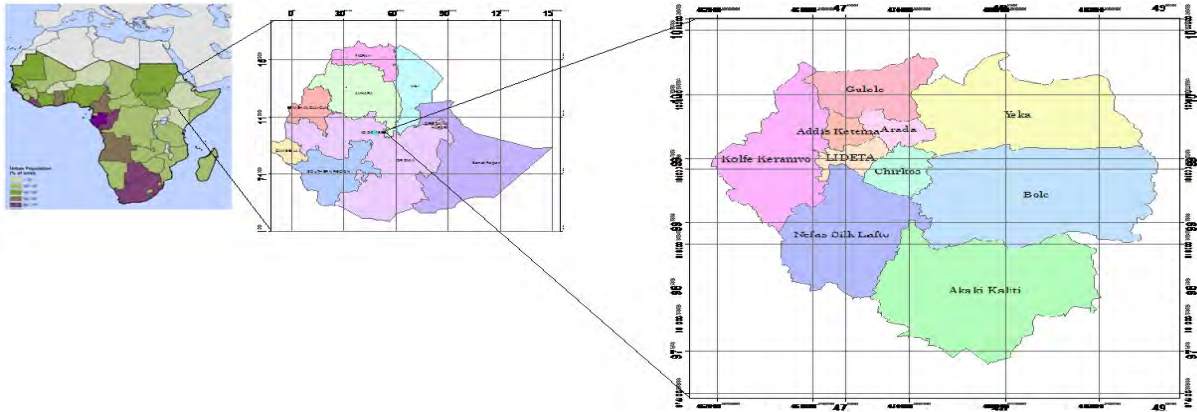

Figure 18: Location Map of Africa, Ethiopia and Addis Ababa

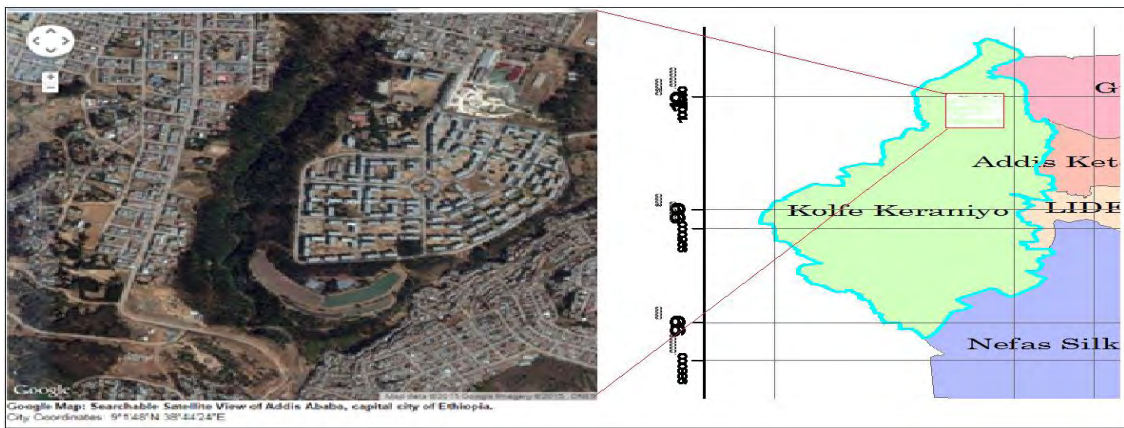

Figure 19: Satellite Image Map of Mickey Leland Condominium Site within Kolfe Keraniyo Sub City



Figure 20: Location of Jemo Gara Condominium Site to be Constructed in Kolfe Keraniyo Sub City

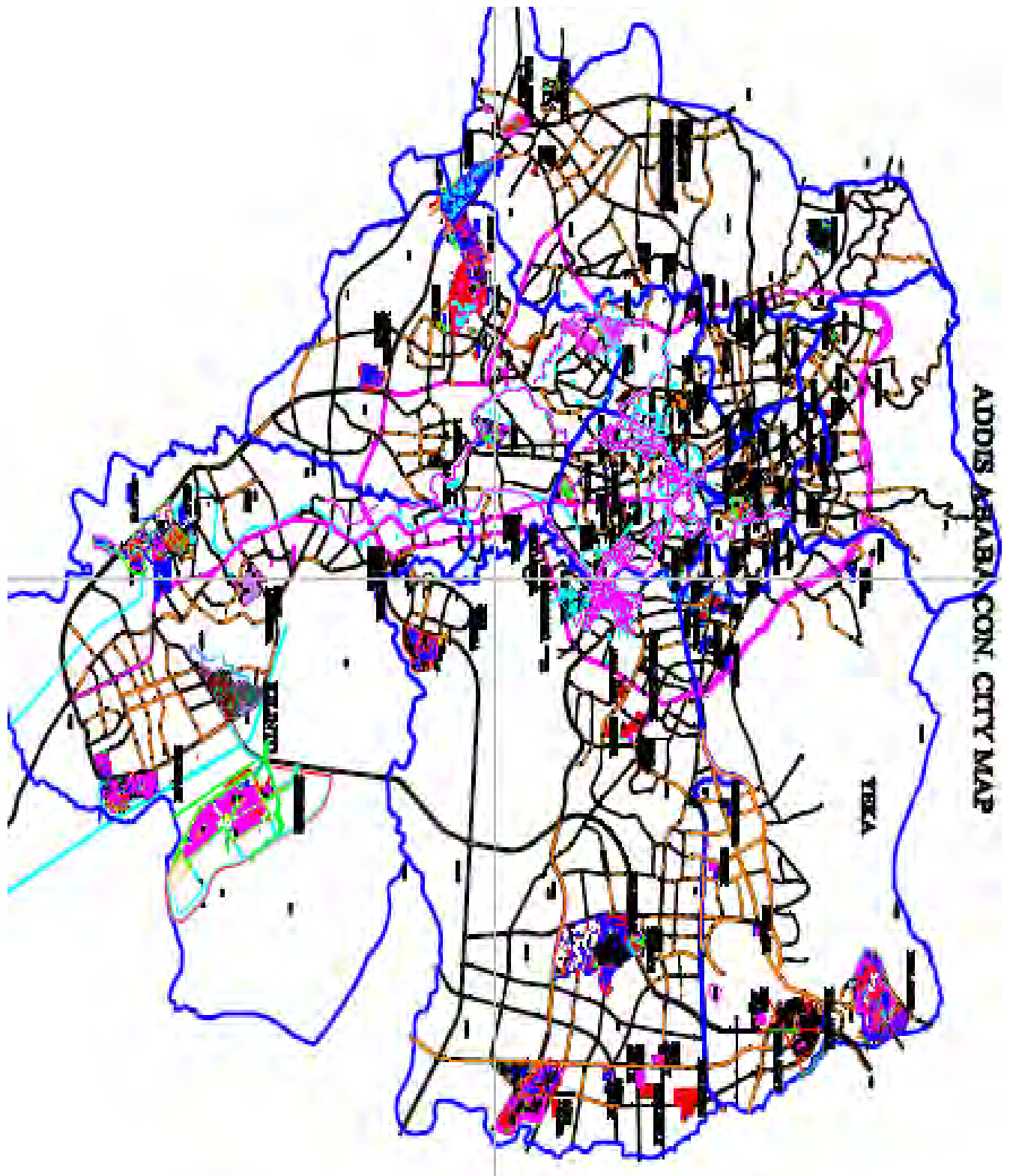

Figure 21: Location Map of Existing Condominium Houses in Addis Ababa City Map

CHAPTER FOUR

4. Grey Water Produced from the Existing and Future Condominium Houses

4.1 Population Projection in Addis Ababa City

Population growth will continue to be one of the most severe demand problems facing Addis Ababa water production. Addis Ababa city has one of the highest population densities from Ethiopian regional cities. According to the results from 2007 G.C from central statistical Agency of Ethiopia census current population is about 2.739 million people by the 2007 G.C and expected to reach 3.686 million and 5.086 people by the year 2020 and 2037 G.C respectively (source Central Statistical Agency population projections for Ethiopia 2007-2037, July 2013). So the city water domestic consumption will more than double by that time, and demand is likely to be more with expected increases in the standard of living. The overall water demand expected to increase to 932,615m³/day by 2020 G.C. (source Addis Ababa Water Supply Project – Stage IIIA, 2005 G.C).

Table 6: Population Growth of Addis Ababa City from 2008-2020

| Year | 2008 | 2009 | 2010 | 2011 | 2012 | 2013 | 2014 | 2015 | 2016 | 2017 | 2018 | 2019 | 2020 |
|--------------------------------|-------|-------|-------|-------|-------|-------|-------|-------|-------|-------|-------|------|-------|
| Population Size (in thousands) | 2,792 | 2,851 | 2,913 | 2,978 | 3,047 | 3,120 | 3,195 | 3,272 | 3,353 | 3,434 | 3,518 | 3602 | 3,686 |

(Source Central Statistical Agency population projections for Ethiopia 2007-2037, July 2013)

The Addis Ababa city consists of 10 (ten) sub cities, which are Nifas silik, Akaki, Gulele, Bole, Kolife, Yeka, Lideta, Kirikos, Addis ketema and Arada sub cities as shown in figure below.

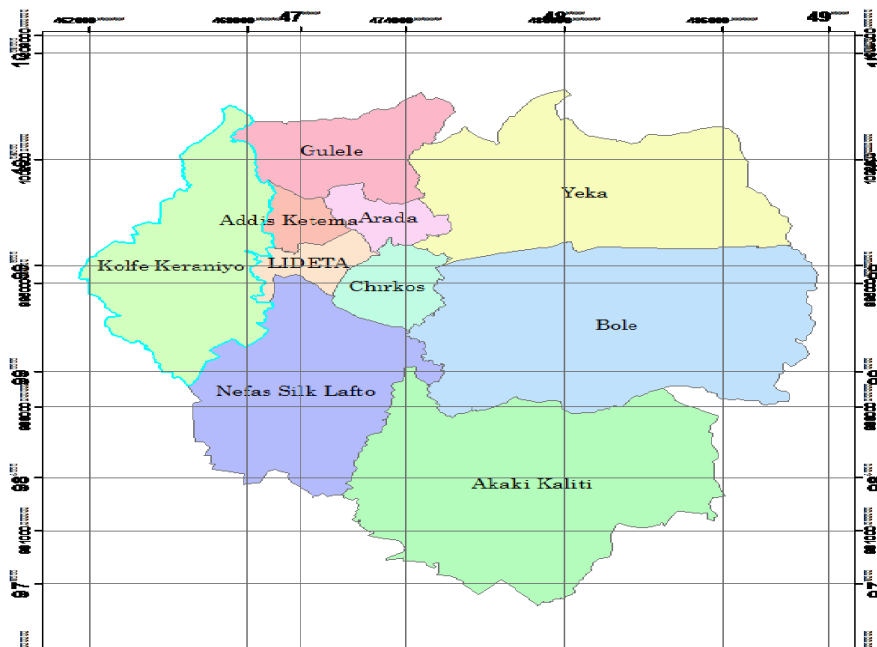

Figure 22: Addis Ababa City Map Including 10 Sub Cities

The number of households that occupy in condominium houses from the beginning of 2004 (1996 in Ethiopian calendar) up to 2006 E.C is 186,978 houses. The total number of people that exists in one house hold is five. Therefore the total number of population that exists in the existing condominium houses is about 934,890 peoples as shown in the table below. In addition to the existing 186,978 houses Addis Ababa housing construction project office planned to construct 700,000 houses up to 2020 E.C which is 3,500,000 people beneficiary.

Table 7: Number of Typologies and Total Number of Houses in Ten Sub-Cities of the Metropolis

| No | Sub city | Com munal | No. of blocks | Area ha. | studio | 1 bed room | 2 bed room | 3 bed room | comm ercial | Total No of houses |
|-------|-------------------|-----------|---------------|----------|--------|------------|------------|------------|-------------|--------------------|
| 1 | Arada | 24 | 87 | 12.29 | 670 | 889 | 1101 | 243 | 87 | 3014 |
| 2 | Yeka | 261 | 1202 | 344.2 | 4971 | 13933 | 8639 | 3533 | 1692 | 33029 |
| 3 | Bole | 260 | 1738 | 600.5 | 15865 | 15499 | 9641 | 4699 | 3764 | 49728 |
| 4 | Kirikos | 28 | 138 | 20.33 | 828 | 1584 | 1093 | 449 | 418 | 4400 |
| 5 | Akaki | 282 | 1774 | 634.5 | 20328 | 11705 | 8390 | 3480 | 1934 | 46119 |
| 6 | Nifas silik lafto | 179 | 1187 | 295.8 | 5292 | 14038 | 8254 | 3414 | 2304 | 33481 |
| 7 | Gullele | 13 | 48 | 5.16 | 307 | 398 | 571 | 14 | 35 | 1338 |
| 8 | Lideta | 12 | 104 | 18.25 | 866 | 1429 | 1048 | 430 | 191 | 3976 |
| 9 | Kolife | 75 | 326 | 74.46 | 1671 | 2719 | 4557 | 1072 | 681 | 10775 |
| 10 | Addis ketema | 13 | 33 | 4.96 | 341 | 393 | 275 | 49 | 47 | 1118 |
| Total | | 1147 | 6637 | 2010.4 | 51139 | 62587 | 43569 | 17383 | 11153 | 186978 |

Source: Addis Ababa housing construction project office 2006 E.C report

4.2 Domestic Water Sources of Addis Ababa City

Major domestic water sources of Addis Ababa city are surface water and ground water. The city of Addis Ababa is at present supplied mainly with surface water from Legedadi, Dire and Gefersa dams with additional supplies from ground water pumped from Akaki well fields to the south of Addis Ababa, and other wells and springs within the city.

Surface water from Legedadi and Dire dam is treated at Legedadi water treatment plant having a production capacity of 195,000m³/day while that from Gefersa dam is treated at Gefersa Water treatment works having production capacity of 30,000m³/day. Similarly, the collective groundwater production from Akaki well fields and other boreholes within and around the city is estimated as 222,333m³/day. Therefore, the total current water production is about 447,333m³/day. (Source: Addis Ababa Water Supply Project –Stage IIIA, 2005 G.C).

4.3 Calculating the Water Usage Per Person and Per Household

Domestic water demand is the amount of water needed for drinking, food preparation, washing, cleaning, bathing and other miscellaneous domestic purposes. The amount of water used for domestic purposes greatly depends on the lifestyle, living standard, and climate, mode of service and affordability of the users.

Each of housing development projects are mainly for residential purpose and therefore the water demand is mainly domestic demand. The following table shows the daily indoor human water requirement for different use of activities including leakage assuming there is adequate water supply coverage.

Table 8: Percentage Composition of Per-Capita Water Demand for Different Purposes

| S/N | Use | Percentage of total daily usage |
|--------------|---------------|---------------------------------|
| 1 | WC | 26.7 |
| 2 | Cloth Washing | 21.7 |
| 3 | Bath & Shower | 18.6 |
| 4 | Kitchen | 17.1 |
| 5 | Leakage | 13.7 |
| 6 | Others | 2.2 |
| Total | | 100 |

Sources: Addis Ababa Water Supply Project -Stage IIIA

Table 9: Composition of Per-Capita Water Demand for Different Purposes

| S/N | Use | Liter per capital per day |
|--------------|---------------|---------------------------|
| 1 | WC | 29.37 |
| 2 | Cloth Washing | 23.87 |
| 3 | Bath & Shower | 20.46 |
| 4 | Kitchen | 18.81 |
| 5 | Leakage | 15.07 |
| 6 | Others | 2.42 |
| Total | | 110 |

Sources: Addis Ababa Water Supply Project -Stage IIIA

The total average domestic water requirement per person has been calculated based on the Addis Ababa Water and Sewerage Authority target average per capital water consumption, **110 l/c/d**. Considering five persons living in a house hold the total average domestic water requirement per a house hold has been calculated $110 \text{ l/c/d} \times 5$ which gives 550 l/d.

The daily water demand changes with the season and days of the week. The ratio of the maximum daily consumption to the mean daily consumption is called the maximum day factor and usually varies between 1.0 and 1.3. According to the Addis Ababa Water Supply project – stage IIIA a maximum day demand of 1.1 is adopted for the city of Addis Ababa.

The peak hour demand is the maximum hourly demand in a given day. Such an event is likely to happen during morning and/or evening hours when most people use water for bathing, washing utensils and cooking. According to the Addis Ababa water supply project – stage IIIA), the hourly water usage varies according to the following pattern

- Low usage 23:00 – 05:00 Hours
- High morning 05:00 – 11:00 Hours
- Moderate 11:00 – 18:00 Hours
- High evening 18:00 – 23:00 Hours

Considering the maximum day demand factor (= 1.1) the maximum daily demand of potable water required per house hold has been calculated $0.550 \text{ m}^3/\text{day} \times 1.1 = 0.605 \text{ m}^3/\text{day}$.

4.4 The Amount of Grey Water Produced and that will be Unused per Person and Per Household

Before expressing the amount of grey water produced and that will be unused it is necessary to calculate the total amount of potable water required per person and per house hold using table 10 as a reference.

Table 10: Grey Water Usage per Person

| S/N | Use | Liter per capital per day | % of total daily use | Used as grey water? |
|-----|---------------|---------------------------|----------------------|---------------------|
| 1 | WC | 29.37 | 26.7 | no |
| 2 | Cloth washing | 23.87 | 21.7 | yes |
| 3 | Bath & shower | 20.46 | 18.6 | yes |
| 4 | Kitchen* | 18.81 | 17.1 | no |
| 5 | Leakage | 15.07 | 13.7 | no |
| 6 | Others | 2.42 | 2.2 | no |
| 7 | Total | 110 | 100 | |

Total grey water 44.33 40.3
 Total non grey water 65.7 59.7

*The reason missing to use kitchen as grey water is the water from kitchen sink have heavy organic matter and suspended solids and needs higher costs for treatment.

Based on data from table 10, the amount of grey water produced is determined. Viable grey water can be collected from cloth washing, bath and showers. The total percentage of water used for those items is 40.3%. Note that toilet water accounting 26.7% of water usage or 29.37 l/c/d meaning that potable water used as toilet flushing would be eliminated while leaving 14.96 l/c/d of grey water for floor washing, gardening and car washing. This means that 100% of the grey water produced can be used. Considering table 10 the amount of grey water produced per person and per household that will be unused is $0.032 \text{ m}^3/\text{c}/\text{day}$ and $0.16 \text{ m}^3/\text{day}$ respectively.

NB: The amount of grey water produced and that will be unused per person, per household, from Jemo Gara condominium houses, from Mickey Leland condominium houses, from existing and future condominium houses detail calculation is shown in **Appendix A**.

4.5 The Amount of Grey Water Produced in Jemo Gara Condominium Houses

Taking table 10 grey water usage per person and considering the calculated values of the total amount of potable water required per person, the total volume of grey water produced per person, the amount of grey water produced after treatment per person, the amount of grey water produced that will be unused per person, the amount of grey water produced in Jemo Gara condominium is 376 m³/day.

Table 11: Number of Typologies, Houses and Hectares in Jemo Gara Condominium Houses

| Block | Communal | 1 Bed room | 2 Bed room | 3 Bed room | Shop | Area | total | Total population |
|-------|----------|------------|------------|------------|------|------|-------|------------------|
| 46 | 35 | 1044 | 563 | 570 | 146 | 32 | 2358 | 12020 |

(Source Addis Ababa housing construction project office)

4.6 The Amount of Grey Water Produced in Mickey Leland Condominium Houses

Taking table 10 grey water usage per person and considering the calculated values of the total amount of potable water required per person, the total volume of grey water produced per person, the amount of grey water produced after treatment per person, the amount of grey water produced that will be unused per person, the amount of grey water produced in Mickey Leland condominium is 740.2 m³/day.

Table 12: The Number of Customers and the Amount of Water Delivered in Mickey Leland

| Month | Year | Customer (No) | Water delivered (m ³ /month) | Water delivered (m ³ /day) |
|-----------|------|---------------|---|---------------------------------------|
| July | 2006 | 4592 | 19,418 | 647.27 |
| August | 2006 | 4591 | 14,264 | 475.47 |
| September | 2007 | 4593 | 19,766 | 658.87 |
| October | 2007 | 4595 | 22,149 | 738.3 |
| Average | | 4593 | 18,899.25 | 629.98 |

Sources: Addis Ababa water and sewerage authority

The selection of these months were expected AAWSA to deliver a maximum efficiency of water because of these four months has a higher ground water and surface water recharge due to higher rain fall duration. The maximum daily demand of potable water required in Mickey Leland condominium houses is **2805.99m³/day**. Whereas the maximum daily amount of potable water delivered in Mickey Leland condominium houses is **629.98m³/day**. This shows that the **water demand** for Mickey Leland condominium houses is now greater than **water supply** capacity of AAWSA which is required an additional demand of **2176.01m³/day**. Table 12 above shows the number of customers the amount of water delivered in two subsequent years with in four months.

4.7 The Amount of Grey Water Produced from the Existing and Future Condominium Houses

Addis Ababa Housing Construction project office aims to construct 400,000 housing units, to create 200,000 jobs and thereby contribute significantly to the national target of reducing urban unemployment by half, to promote the development of 10,000 small enterprises on a sustainable basis in the construction industry, to enhance and build the capacity of contractors, consultants, engineers and foremen as well as suppliers of construction materials in the period of 2006-2010 G.C (UN-HABITAT, 2011). But Addis Ababa Housing construction project office has been constructed **186,978** houses in ten sub-cities of the Metropolis incorporating varies unit typologies into each condominium block such as studio, 1-bedroom, 2-bedroom, and 3-bedroom and communal unit types starting from the program launched in 2004 (1996 in the Ethiopian calendar) up to 2006 E.C as shown in table 7 above. Considering 186,978 houses the amount of grey water produced from the existing condominium houses is 29,839 m³/day.

In the next 14 years from 2006-2020 E.C Addis Ababa Housing Construction project office plan to construct 50,000 housing units yearly, to create jobs significant to the national target of reducing urban unemployment, to promote the development of small enterprises on a sustainable basis in the construction industry, to enhance and build the capacity of contractors, consultants, engineers and foremen as well as suppliers of construction materials. In order to construct 50,000 housing units yearly Addis Ababa Housing construction project office has been expanded another 8 branch project offices in addition to ten sub-cities of the metropolis (source AAHCPO). In the future 14 years AAHCPO has planned to construct a total of 700,000 houses considering varies unit typologies. Regarding 700,000 houses the amount of grey water produced from future condominium houses is 111,711.6 m³/day. The table below shows the summary of amount of grey water produced per person, per household, in Jemo Gara, in Mickey Leland condominium houses, existing condominium houses and future constructed condominium houses.

Table 13: Summary of Amount of Grey Water Produced

| No | Description | Per person | Per house hold | Jemo Gara* condominium houses | Mickey Leland condominium houses* | Existing condominium houses | Future condominium houses |
|----|---|------------|----------------|-------------------------------|-----------------------------------|-----------------------------|---------------------------|
| 1 | The total amount of potable water required (m ³ /day) | 0.11 | 0.55 | 1296.9 | 2550.9 | 102837.90 | 385000 |
| 2 | The maximum daily demand of potable water required (m ³ /day) | 0.121 | 0.605 | 1426.6 | 2805.99 | 113121.69 | 423500 |
| 3 | Total waste water produced (m ³ /day) | 0.088 | 0.44 | 1037.5 | 2041 | 82270 | 308000 |
| 4 | The total volume of grey water produced (m ³ /day) | 0.035464 | 0.17732 | 418 | 822 | 33155 | 124124 |
| 5 | The amount of grey water produced after treatment (m ³ /day) | 0.0319176 | 0.159588 | 376 | 740.2 | 29839 | 111711.6 |
| 6 | The amount of grey water produced that will be unused (m ³ /day) | 0.0319176 | 0.159588 | 376 | 740.2 | 29839 | 111711.6 |

*NB The amount of grey water produced that will be unused (m³/day) in Mickey Leland and in Jemo Gara condominium houses is incorporated in the existing and future construction condominium houses respectively.

Table 13 shows that the amount of grey water produced that will be unused is 141,550.6 m³/day from Existing condominium houses and future condominium houses 29,839 and 111,711.6 m³/day respectively. Addis Ababa water and sewerage authority saves 141,550.6 m³/day potable water using water demand management of condominium houses considering grey water reusing.

4.8 Cost of Water in Addis Ababa

Addis Ababa water and sewerage authority costs the water considering domestic use (residence), non domestic uses (commercial uses), maintenance costs and pipe diameter varying from meter cube to meter cube depending on the rate being offered from the provider in order to support low income households.

Table 14: Cost of Water and tariff group in Addis Ababa

| No | 1 | 2 | 3 | 4 | 5 | 6 | 7 |
|---------------------|------|------|-------|--------|---------|---------|-------|
| Group in meter cube | 0-7 | 8-20 | 21-40 | 41-100 | 101-300 | 301-500 | >500 |
| Cost (ETB) | 1.75 | 3.80 | 4.75 | 5.95 | 7.45 | 9.30 | 11.60 |

CHAPTER FIVE

5. Socio-Technical Issues of Grey Water Reuse as Part of Water Demand Management

Socio cultural aspects are important, as they will determine the acceptance of a system and the way it used. As always, positive public opinion is the key to success for a reuse system. According to the review related to the concern subject I carried out by interviewing experts who were dealing or having contact with the subject at different levels, a questionnaire was developed with closed –ended questions for Mickey Leland condominium residents and open –ended questions for Jemo Gara condominium house construction supervision professional engineers and Addis Ababa water and sewerage authority managers. The questionnaire was designed in Amharic language, as most of the target population in Mickey Leland condominium residents was expected unfamiliar with the English language. On the other hand in Jemo Gara condominium housing construction supervision professional engineers and AAWSA managers the questionnaire was designed in English language. Unnecessary personal data, complex and duplicated questions were avoided.

The questionnaire consisted of four sections:

1. Personnel information in Mickey Leland condominium houses
2. Consumer opinion about water services provided by AAWSA
3. Consumer opinion about grey water reusing
4. Interview results from Jemo Gara condominium housing construction supervision professional engineers and Addis Ababa water and sewerage authority managers

The net size of the study sample was 232 taking 5% of the total households which is 4638. A sample of 20 questionnaires was returned to the same households in order to check the questionnaire reliability. After data was received, it was tested and analyzed. 212 persons responded to questionnaire where as 20 persons can't be responded due to different reasons. It has to be noted that the questionnaire included of mostly qualitative questions which were answered by yes/no type answers.

5.1 Personnel Information in Mickey Leland Condominium Houses

This section was related with the personal information such as address, occupation, sex, age, number of family member, education and income. The survey result explored the following data items and with acceptable results as follows.

Question 1 your occupation?

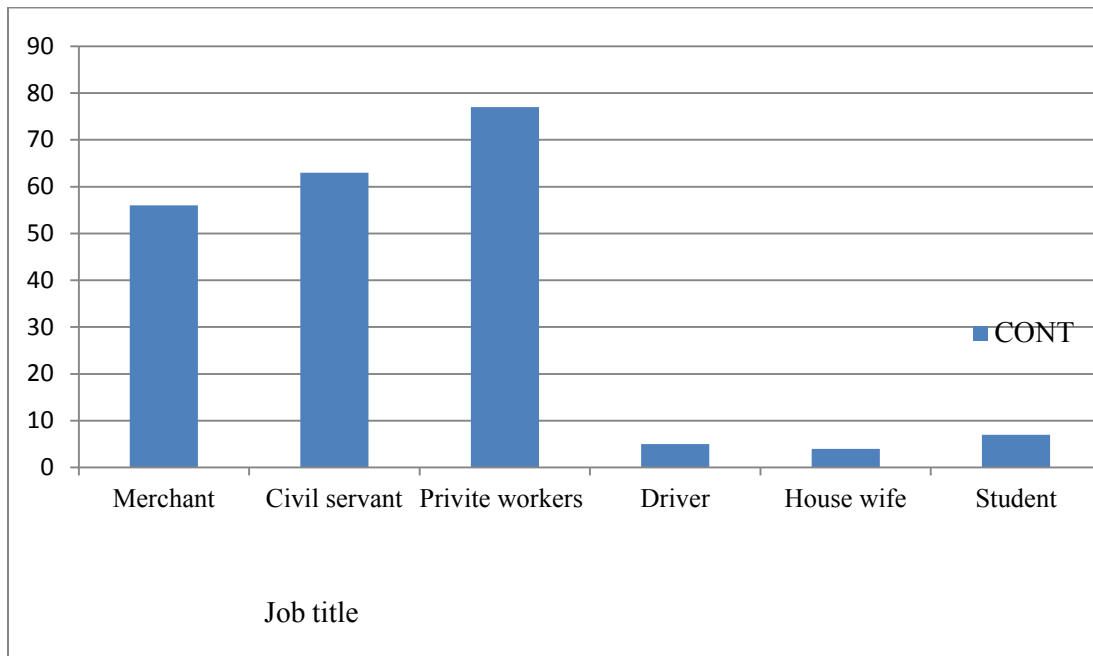

Figure 23: Category of Occupation

The distribution of the study sample by category of job title as indicated in figure 23 shows that 77 (36.32%) of the sample is private workers, 63 (29.72%) of the sample is counted civil servants, 56 (26.42%) of the sample is counted merchants, 16 of the sample is counted (29.72%) others such as drivers, house wife and students.

Question 2 your sex?

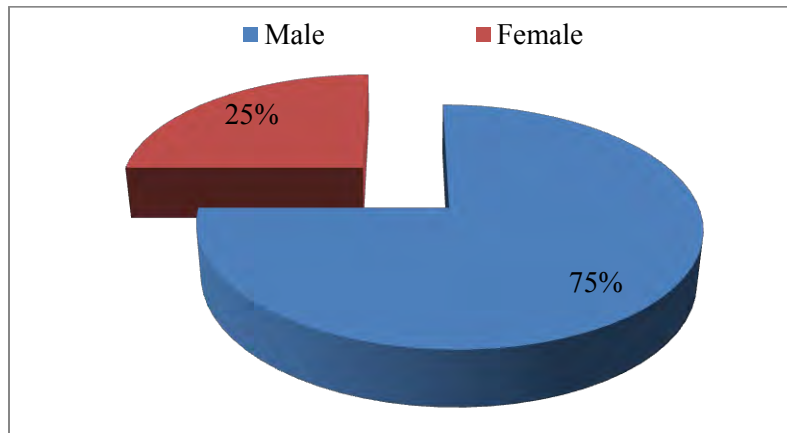

Figure 24: Category of Sex

Regarding category of sex from the study sample as indicated in figure 24 shows that 75% of the samples are males and 25% of the samples are females.

Question 3 your age?

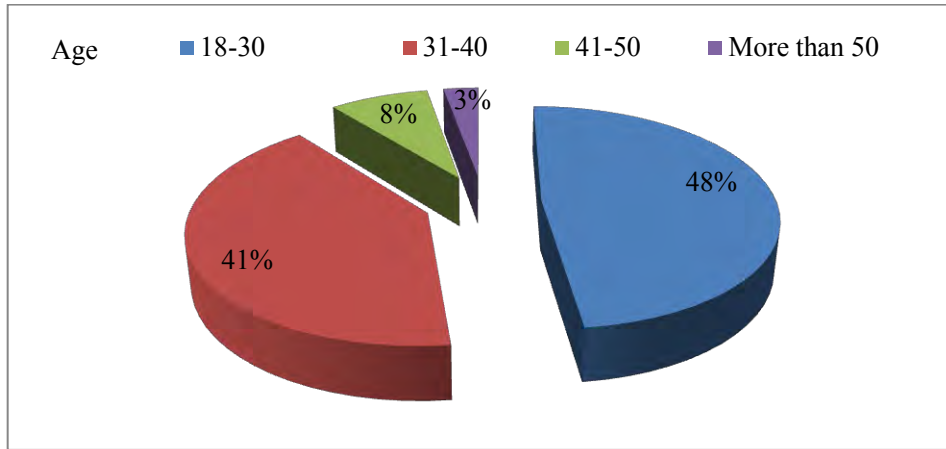

Figure 25: Category of Age

The vast majority of the study sample (75%) was from males and from 212 samples 48% were in the age category from 18-30 and 41% were in the age category from 31-40 years old, Mickey Leland residence population is considered a very young within the population.

Question 4 number of your family members?

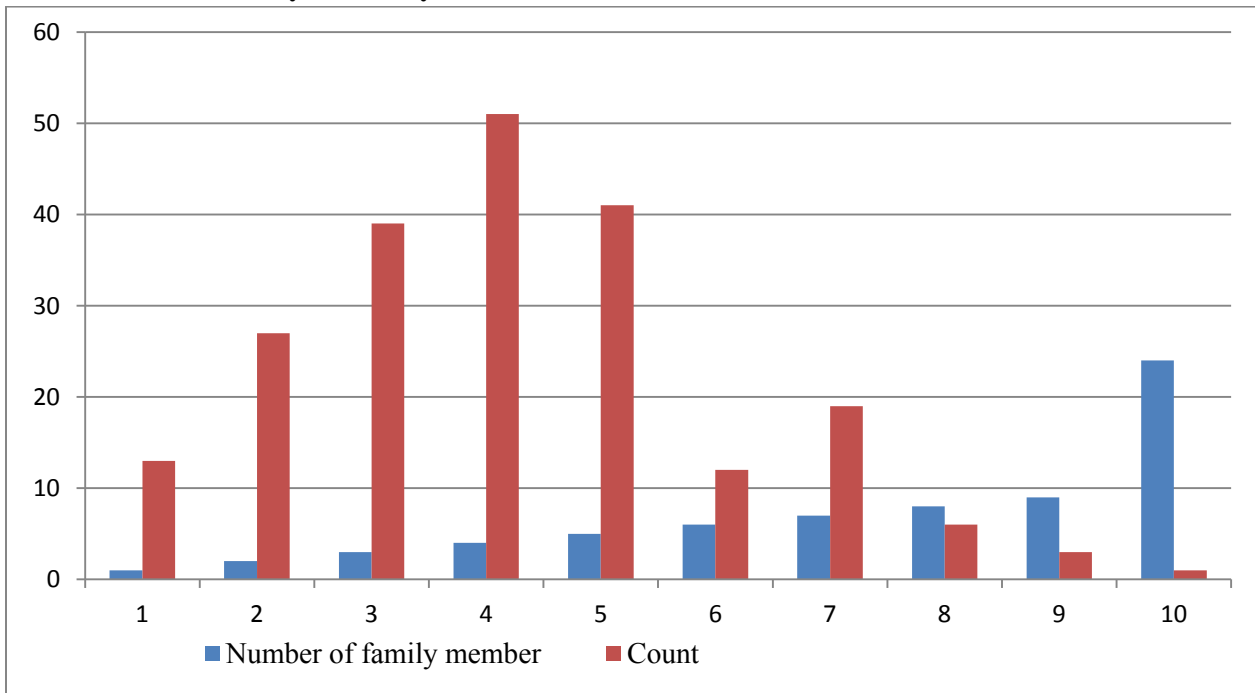

Figure 26: Number of Family Members

The sample is representative of Mickey Leland condominium residence population; also an average number of family members in the house hold is equal to 4.23, as shown in figure 26.

Question 5 educational level

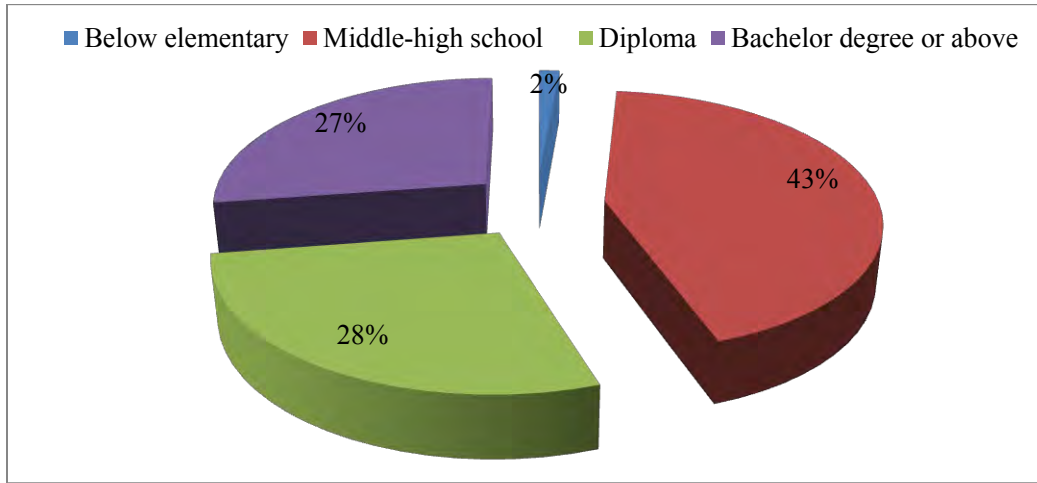

Figure 27: Educational Level

Distribution of the study sample by category of qualification as indicated in figure 27 shows that 43 % of the sample shows Mickey Leland condominium residence have middle to high school low educational community.

Question 6 what is family middle monthly income

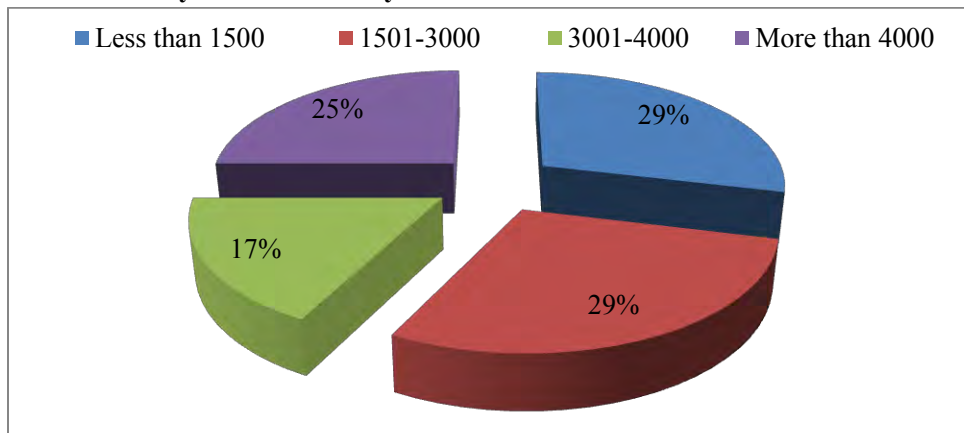

Figure 28: Income Categories for Mickey Leland Condominium Residence

The distribution of the study sample by category of monthly income as indicated in figure 28 shows that 58% of the sample is less than 3000 ETB, 25% of the sample is in between 3001-4000 ETB and 17% of the sample is above 4000 ETB.

5.2 Consumer Opinion about Water Services Provided by AAWSA

This section incorporates general information having water shortage problems, a bit for using the absence of water and the options to get water during the absence of water and bill price.

Question 7 how much for water do you pay monthly?

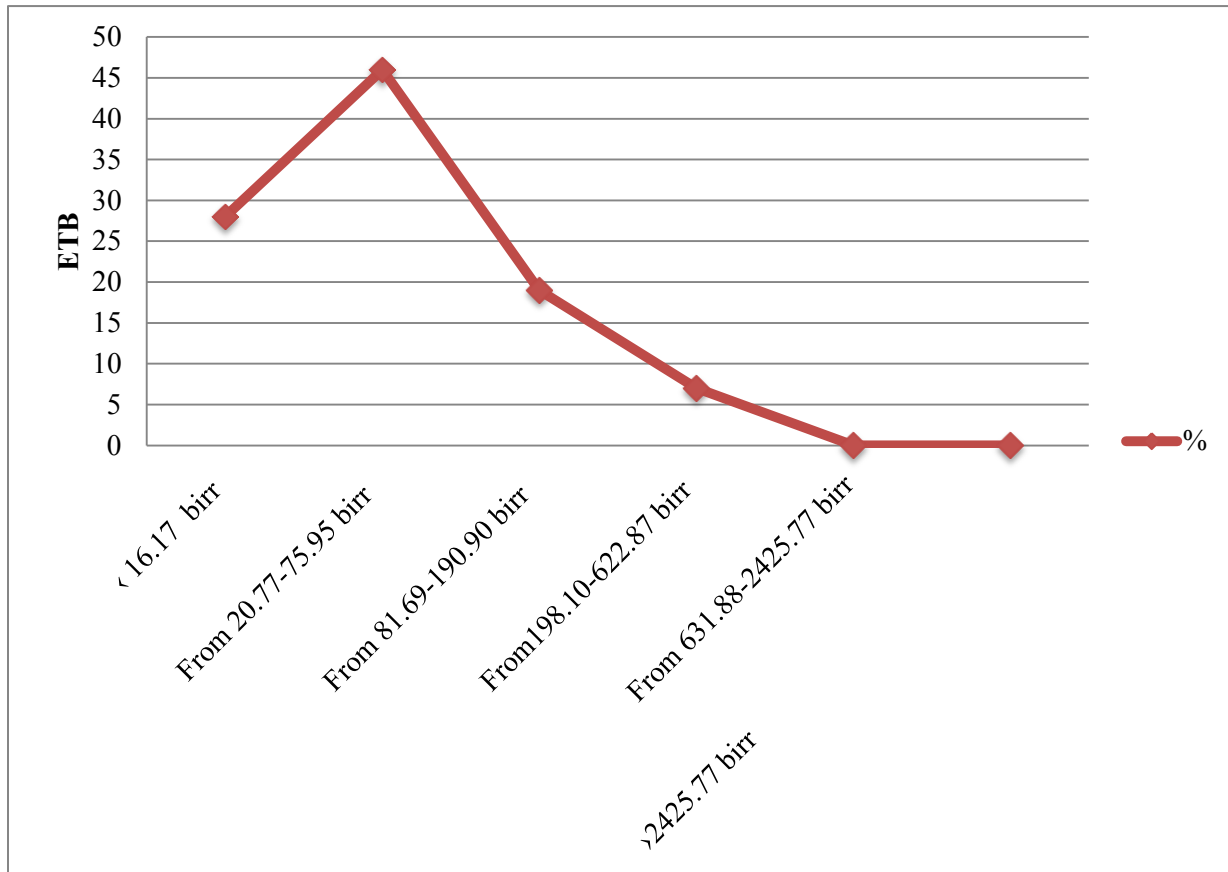

Figure 29: Monthly Water Bills in Mickey Leland Condominium Residence

It's obvious that 74% of the samples have a bill value less than 75.95 ETB per month and 26% of the sample has a bill between 81.69-622.87 ETB. The result shows there are direct relations between water tariff and water quantity consumed. Referring table 12 the water demand for Mickey Leland condominium houses is now greater than water supply capacity of AAWSA which is required an additional demand of 2176.01m³/day and the bill price shows there is shortage of water supply in Mickey Leland condominium houses (water price will include the cost, maintenance cost, expectation of houses (residential or commercial) and expectation of pipe size.

Question 8 Do you that you live in an area where water shortage is a problem?

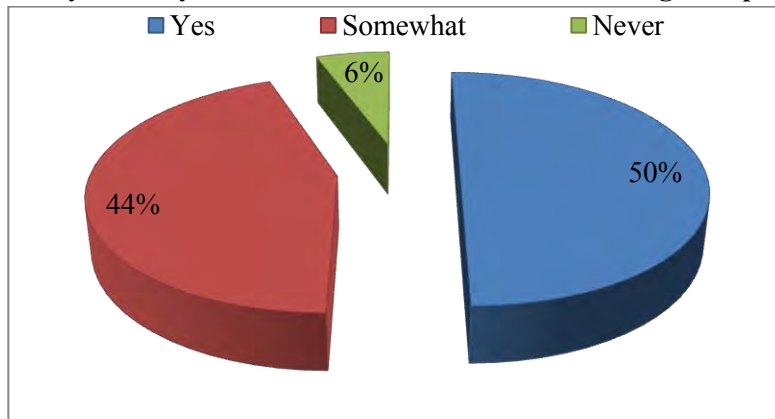

Figure 30: Water Shortage Problems

The results from question 8 shows that only 6% of them thinking that the area of Mickey Leland condominium residence has not a water shortage problems. Whereas, most people responding that 50% of them has a water shortage problems and 44% of them has a water shortage problems some times. This is reasonable because there is a water shortage problem for now. So they would be more willing to adopt water demand management considering grey water recycling.

Question 9 do you think you do your bit to save water? Bit means any material to store water

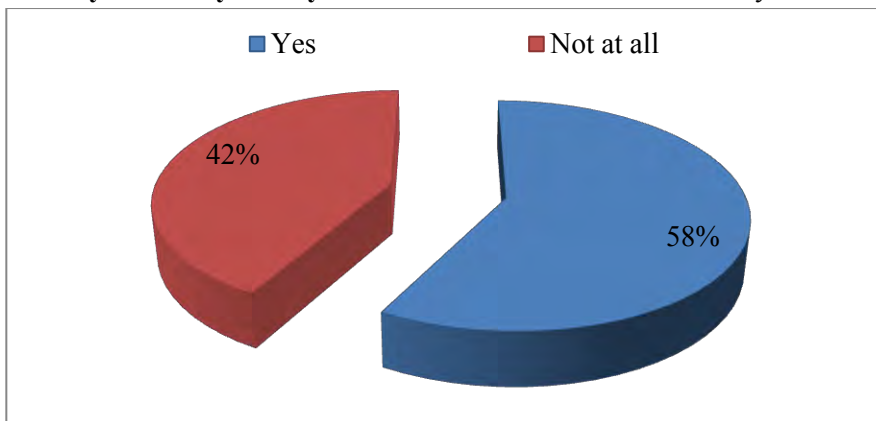

Figure 31: Using Bit to Save Water

The results from question 9 show that 58% of the survey result shows that they use a bit to use potable water during the absence of water. Whereas 42% of the survey result shows that they didn't use bit to save potable water.

Question 10 what are the options that you get water during the absence of water?

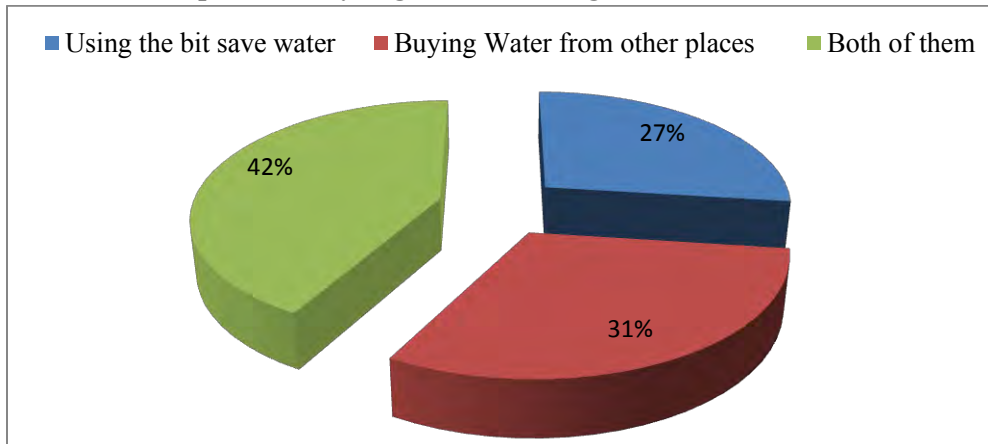

Figure 32: Options to Get Water during the Absence of Water

Regarding to the water usage during the absence of potable water 42% of the survey result shows that using either buying from other places or using a bit if it is not empty for storing an emergency periods. Whereas 31 and 27 % of the survey result shows that buying water from other places and uses bit when they are storing for emergency periods respectively.

Question 11 how you would describe yourself regarding water use

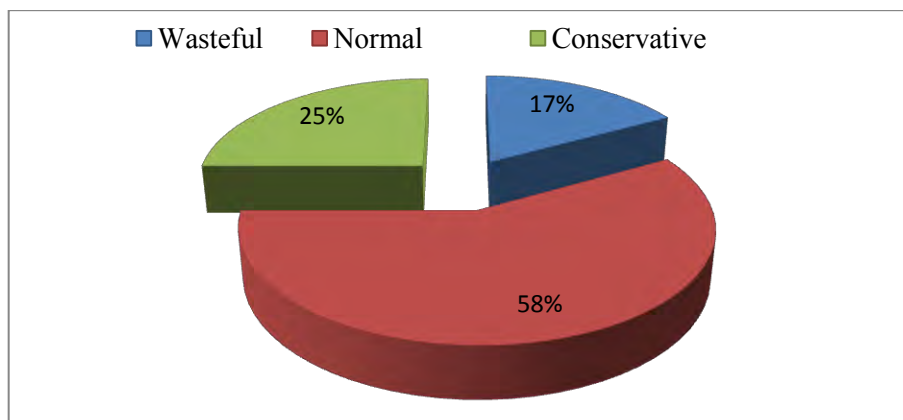

Figure 33: Description of the Community Regarding Water Use

The result from this question shows that only 25% of the respondents consider that they are conservative in water utilization. On the other hand there are 17% of the people that announce they are wasteful in water use. But the majority of the users 58% consider themselves as normal in water consumption. There is a possibility that the users consider themselves normal or waste full would be more willing to adopt any water conservation measures.

5.3 Consumer Opinion about Grey Water Reusing

This section shows about the results of consumer behavior such as the methods for washing their clothes, the places where the wastes from cloth washing spill out, using grey water, the purposes using grey water and the willingness for using grey water if a piloting treatment technology is installed in their home.

Question 12 in which methods you are washing your clothes?

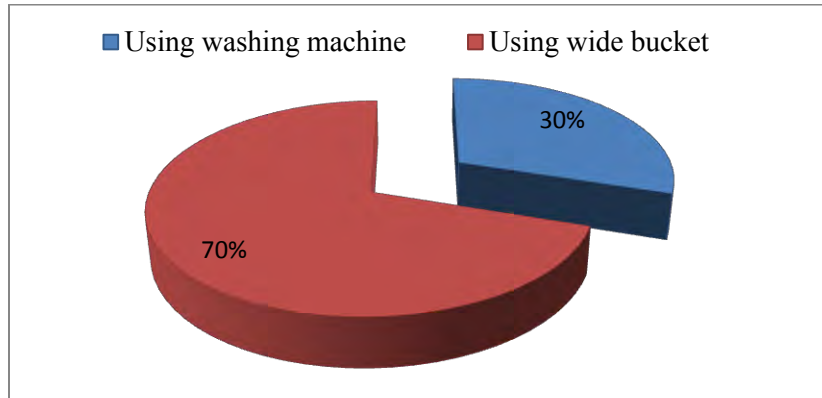

Figure 34 : Methods Using for Washing Clothes

The results from this question shows that only 30% of the users washing their clothes using washing machine where as 70% of the user washing their clothes using wide bucket(,safa"). This means that a great portion does not use a water efficient washing machine as the respondent's results are presented in figure 34.

Question 13 where are you spilling out the wastes from cloth washing?

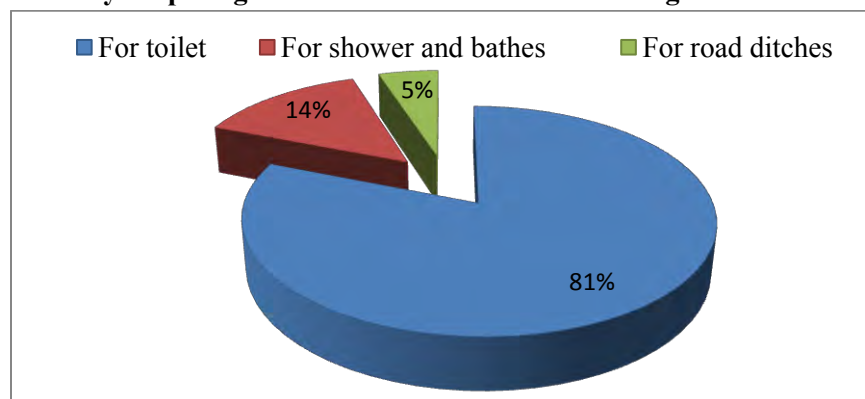

Figure 35: Spilling Out of Wastes from Cloth Washing

It is obvious that 81% of the samples spilling out the wastes from cloth washing for toilet flushing, 14 % of the samples spilling out in to shower and bathes whereas a least amount which is 5% spilling out in to road ditches.

Questions 14 are you willing to use grey water; if a piloting treatment technology is installed in your home?

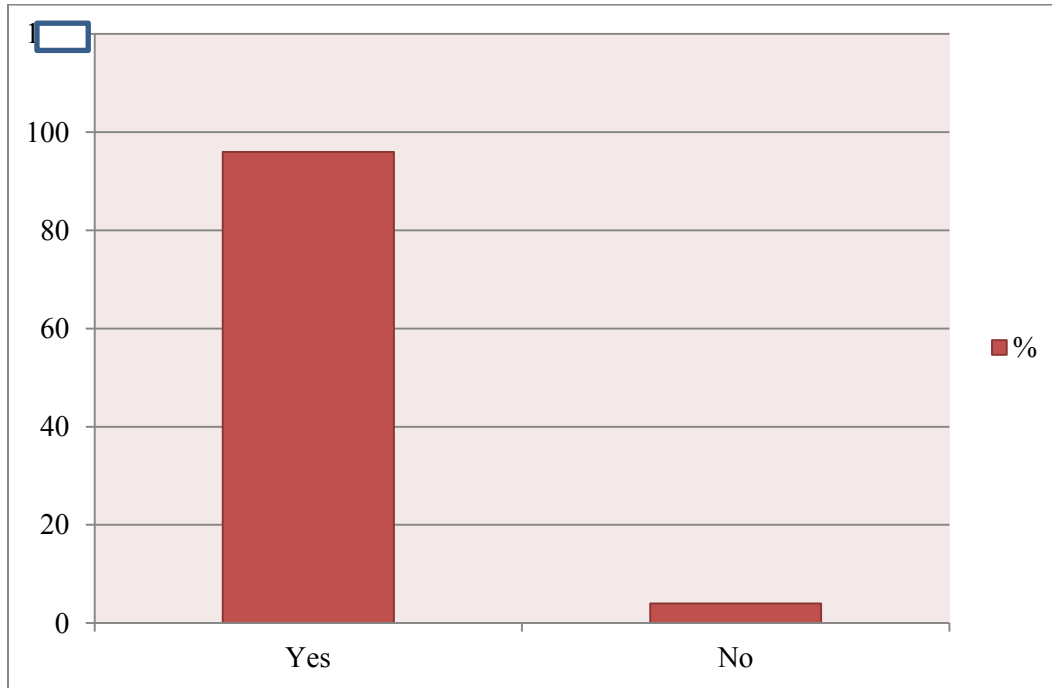

Figure 36: Willingness to Reuse Grey Water Using a Piloting Treatment Technology

The result from this question shows that only 4% of the respondents have not willingness to reusing grey water using a piloting treatment technology. Whereas a vast majority of the respondents which is 96% have willingness to reusing grey water using a piloting treatment technology for saving potable water.

5.4 Interview Results from Jemo Gara Supervision Professional Engineers

From new condominium housing construction consultant engineers the net size of the study sample was 10. Out of 10, 7 professional engineers responded to an interview where as 3 persons can't be responded due to different reasons. It has to be noted that the questionnaire includes an open ended questions which is not answered by yes/no type answers because of getting relevant data whether there is sufficient water supply for condominium houses, the advantages and disadvantages of grey water recycling, advantage and disadvantages to achieve through separate plumbing of black water and grey water, positive public opinion for the acceptance of grey water recycling, applicability of grey water recycling, existing grey water treatment technologies and the consideration to be under taken for the selection of grey water technologies.

Concerning sufficient water supply for condominium houses the interview result from this question shows that 100% of the respondents answered there is no sufficient water supply for condominium houses because of shortage of water in the town and lack of pressure to arrive. Regarding the advantages and disadvantages of grey water recycling; the advantages of grey water recycling from the interview result

shows; 71.43% has an advantage to full fill the gap between the supply and the gap where as 28.57% for environmental control. The disadvantages of grey water recycling from the interview result shows; 100% responses a disadvantage of high running costs, 28.57% land space required, 14.29 a need of treatment technology and 14.29 low social acceptability.

Considering the advantage and disadvantages to achieve through separate plumbing of black water and grey water; the interview result shows; 85.71% easy to use the grey water recycling, 14.29 easy for maintenance. The disadvantages of grey water recycling from the interview result 28.57% shows no disadvantages, 57.14% a need of additional costs and 14.29% land space required. Regarding positive public opinion for the acceptance of grey water recycling the interview result from this question shows that 57.14% of the respondents answered there is a positive public opinion for the acceptance of grey water recycling because of shortage of water in the town, where as 42.86% of the respondents answered there is a negative public opinion for the acceptance of grey water recycling because of lack of awareness.

Whereas the relevant applicable purposes for grey water recycling the respondents shows 14.29% for toilet flushing, 14.29% floor cleaning, 28.57% gardening, 28.57% for car washing and 71.43% for all. Concerning grey water treatment technologies, the interview result from this question shows that the interview result from this question shows that 85.71% of the respondents answered they didn't know grey water treatment technologies where as 14.29% of the respondents answered they know recycling industrial wastes for irrigation purposes in Ethiopia (flowering development investors).

Regarding the considerations to be under taken for the selection of grey water technologies

| Quality of the grey water to be treated | Land space required for construction | Odor nuisance | Relative investment and running costs | Personnel skills required | Familiarity of the technology in the city |
|---|--------------------------------------|---------------|---------------------------------------|---------------------------|---|
| 14.28% | 28.57% | 14.28% | 100% | 42.86% | 28.57% |

100% of the interview results shows for the consideration to be under taken for the selection of grey water technologies are investment costs, where as land requirements and the quality of treatment technology is 14.28%, the interview results on the consideration of familiarity of the technology in the city and land space required for construction is 28.58%. On the other hand the personnel skill required for the selection of grey water technologies the interview results shows 42.86%.

5.5 Interview Results from Addis Ababa Water and Sewerage Authority Managers

From new condominium housing construction Addis Ababa water and sewerage authority managers the net size of the study sample was 2. But additional two managers were responded for an interview which is a total of 4 managers responded. It has to be noted that the questionnaire included of an open ended questions which is not answered by yes/no type answers because of receiving sufficient amount of relevant data's whether there is sufficient water supply for condominium houses, the advantages and disadvantages of grey water recycling, advantage and disadvantages to achieve through separate plumbing of black water and grey water, positive public opinion for the acceptance of grey water

recycling, applicability of grey water recycling, existing grey water treatment technologies and the consideration to be under taken for the selection of grey water technologies.

Concerning sufficient water supply for condominium houses the interview result from this question shows that 100% of the respondents answered there is no sufficient water supply for condominium houses because of shortage of water in the town, increasing population, increasing economic development and way of living standards and increasing construction. Regarding the advantages and disadvantages of grey water recycling; the advantages of grey water recycling from the interview result shows 75% has an advantage to full fill the gap between the supply and the gap. The disadvantages of grey water recycling from the interview result shows; 25% humans thinking as the grey water considering as potable water and they may be used as drinking purposes and there is the effect of health problems for humans because of the grey water treatment is not the same as the required standard of potable water and all of the managers interview result shows grey water recycling takes high running costs.

Considering the advantage and disadvantages to achieve through separate plumbing of black water and grey water; the interview result shows; 100% of the respondent's says it has an advantage to use the grey water recycling easily. The disadvantages of grey water recycling from the interview result shows 100%: because of a need of additional costs whereas two of the managers says even if there is additional costs human satisfaction considered. Keep in mind that the disadvantages of grey water recycling 100% and the disadvantages of grey water recycling 100% shows that during interview all Manager explains separate plumbing of black water and grey water has their own advantage and disadvantages.

Regarding positive public opinion for the acceptance of grey water recycling the interview result from this question shows that 25% of the respondents answered there is a positive public opinion for the acceptance of grey water recycling because of shortage of water in the town, where as 75% of the respondents answered there is a negative public opinion for the acceptance of grey water recycling because of lack of awareness. Whereas the relevant applicable purposes for grey water recycling the respondents shows 25% for toilet flushing, 75% floor cleaning, 75% gardening and 50% for car washing. Concerning grey water treatment technologies the manager knows the interview result from this question shows that 50 % of the respondents answered they didn't know grey water treatment technologies where as 50% of the respondents answered they know grey water treatment technologies in Sudan, Dubai and Israel among the technologies are oxidation pond, activated sludge, MBR and MBBR. Remember that the percentage variation shows that there is a redundancy from the respondents for the relevant applicable purposes for grey water recycling.

Regarding the considerations to be under taken for the selection of grey water technologies

| Quality of the grey water to be treated | Land space required for construction | Odor nuisance | Relative investment and running costs | Personnel skills required | Familiarity of the technology in the city |
|---|--------------------------------------|---------------|---------------------------------------|---------------------------|---|
| 25% | 25% | 25% | 100% | 75% | 25% |

100% of the interview results shows for the consideration to be under taken for the selection of grey water technologies are investment costs, where as land space requirements, the quality of treatment technology, odor nuisance and familiarity of the technology in the city is 25%, the interview results on the consideration of personnel skill required for the selection of grey water technologies shows 75%.

The considerations to be under taken for the selection of grey water technologies from supervision professional engineers and Addis Ababa water and sewerage authority managers summarized as follows.

| Interview result from professionals & managers | Quality of the grey water to be treated | Land space required | Odor nuisance | investment and running costs | Personnel skills required | Familiarity of the technology in the city |
|--|---|---------------------|---------------|------------------------------|---------------------------|---|
| Sum out of 200% | 39.28% | 53.57% | 39.28% | 200% | 117.86% | 53.57% |
| Translated in to 100% | 19.64 | 26.785 | 19.64 | 100 | 58.93 | 26.785 |
| Translated in to 30 point | 5.892 | 16.071 | 5.892 | 30 | 17.679 | 16.071 |
| Take as a weight factors | 10 | 15 | 10 | 30 | 20 | 15 |

Sum out of 200% indicates the sum of total grade from professional engineers and managers interview results. For example under the considerations of selecting grey water technologies on the requirements of personnel skills required the interview result from professional engineers shows 42.86% where as from managers 75% with a grand total of 117.86% out of 200%. When it is translated in to 100%, 58.93% and gives a weighting factor 20 point. regarding the selection of grey water technologies the interview result shows relative investment and running costs is the highest score which is 100% and give a weighting factor 30 out of 30. Whereas quality of the grey water to be treated and protection of the environment (the public health) and odor nuisance is lower score give a weighting factor 10 rather using 5.892 considering the comparison matrix simple wise for calculation. Concerning the land space required and familiarity of the technology in the city the interview result shows 15% and gives a weighting factor 15 point. Remember that 30 point is selected based on the researchers feeling.

From the identification of different possible socio-technical issues of grey water reuse as part of water demand management and the findings from questionnaire survey of Mickey Leland condominium residents; it has to be noted at this stage most of the questionnaire included of mostly qualitative questions which were answered by yes/no type answers the analysis was qualitative and comments were made on its question. So the analyzing of the results was limited and it was not in the scope of this study to identify connections between variables. This would not contribute to answering the research questions. However, discussion of the findings from the questionnaire survey presented below.

- There is a difficulty in water quantity and continuity that reaches households; and these shows that there must be grey water recycling for toilet flushing to full fill the gap.
- The vast majority of the customer's bill price is very small, and it is clear that the consumer doesn't feel (complain) the bill price increases when water quantity and continuity exist throughout the day.
- Regarding grey water reuse in house hold, there is a small portion of water consumer's trends to reuse water in their daily life where as a large portion of water consumers spill out in toilet, shower and road ditches.
- Habit was the main reason for not applying grey water for non potable water. According to the surveys that considers using recycling grey water for non potable water there is a small portion of water consumer's had bad behaviors based on the religious causes. On the other hand the interesting thing is that there is an amazing connection for recycling grey water from hand washing for toilet flushing as shown in section 5.6.1 step 3.

- There is a significant positive aptitude of the water users that considers themselves waste full in water use. It is clear that there are potential savings in water by those users, if a grey water recycling program is to be implemented.
- There is a negative application concerning water efficient devices. From the answers of the customers that are using wide bucket („safa“) for washing their clothes is very high. While that the positive application using machine for efficient devices washing their clothes is very low. For recycling there is a positive application the customers that are using wide bucket to supply untreated grey water in to the barrel manually without connection of flexible pipes.
- Consumers are very positive willingness“s to reuse grey water using unfamiliar piloting treatment technology. But there is low potential of monthly income that shows a negative challenge to install grey water reusing piloting treatment technology.

In addition to the above there was an interview taken from AAWSA managers and professional engineers. Although interviewing only four managers and seven professional engineers was taken the reliability and valuable information for answering the research questions is very strong. The findings are presented below.

- Both the managers and professional engineers elaborate there is major water problem with water scarcity in the city and condominium houses. Generally there is a water supply problem in the town because of increasing population, increasing economic development and way of living standards, increasing construction and low pressure to deliver in high elevation areas.
- There is a positive opinion on the advantages of grey water recycling to full fill the gap and there is also a positive opinion on separate plumbing of black water and grey water. But there is negative opinion with additional running costs.
- Managers and professional engineers expectations is that, there is a positive public opinion for the acceptance of grey water reusing because of the existence of water shortage in the town.
- There is also great appreciation to use the grey water for toilet flushing, floor cleaning, gardening and car washing. But there is less appreciation to use the grey water for cloth washing.
- Considering the known grey water treatment technologies and the consideration to be under taken for the selection of grey water technologies the interview result shows oxidation pond, activated sludge, MBR and MBBR are some of the treatment technologies and the quality of the grey water to be treated, land space required for construction, odor nuisance, relative investment and running costs, personnel skills required and familiarity of the technology in the city are some of the criteria“s to be under taken for the selection of grey water technologies.

5.6 Piloting Treatment Technology the Case of Mickey Leland Condominium Houses

5.6.1 Two-Barrel Plastic Grey Water Treatment technology

The research materials that are used in this study will bought from „Mercato“ specifically „Shera tera“, „Minalesh“ village and „Chid tera“ the material lists are, Barrel plastic, Union, Male adapter (plug), Gate valve, Connector (nipples), Coupling, Fiber, Faucet, Flexible steel pipe, Filter material, Sand and Gravel.

The research methodologies following in this study are:-

Separation of grey and black water is achieved through separate plumbing. The water led through household in separate sewage systems making a separate treatment possible. For **new condominium**

houses this can be easily implemented during the construction phase, but for **the existing condominium** houses where a combined system is in use separation can be difficult since it requires big parts of the old plumbing to be reconstructed. Therefore to study the research in **the existing condominium** houses (in the case of Mikeley Land condominium houses) a barrel plastic piloting grey water treatment technology can be used for each house hold manually used. Barrel plastic grey water treatment technology can be easily reused for toilet flushing, floor washing, outdoor plant, car washing, lawns /area of grass, e.g. schools, athletics fields and green areas/, Irrigation of gardens /flower/, machine washing /cloth washing/ and fire protection.

The selection of barrel plastic grey water treatment technology for recycling grey water is very important using for each house hold on several factors.

❖ **Available space**

Space requirements as a selection criteria are in the process of assessing the suitability of sites for construction grey water treatment technology. A barrel plastic type grey water treatment technology is an on-site system which is used for **low income households** to reuse treated grey water and it is a method of technology which is the grey water treatment takes place at the point or nearest of grey water production like within individual houses without transportation for using treated grey water for different purposes. The approximate size required for the installation of this technology is 0.25m² land required inside homes, which is very small land required and each house hold can be install this technology.

❖ **Plan or design**

Barrel plastic grey water treatment technology can not be a need of professional engineer for designing. It is either designed or installed by unskilled man powers or simply buying the Barrel plastic grey water treatment technology from „Mercato“ specifically „Shera tera“, „Minalesh“ village and „Chid tera“.

❖ **Construction procedures and costs**

From table 15 below the total cost incurred to install the barrel plastic piloting treatment technology is **586 ETB**.

Table 15: Total Cost Incurred to Install the Barrel Plastic Piloting Treatment Technology

| No | Material | Unit | Size | Qt | Cost (ETB) | Total cost (ETB) |
|---------------------|---------------------|-------|-------|----|------------|------------------|
| 1 | Barrel plastic | liter | 40 | 2 | 110 | 240 |
| 2 | Union | inch | ½ | 2 | 60 | 120 |
| 3 | Gate valve | inch | ½ | 1 | 6 | 60 |
| 4 | Connector(nipples) | inch | ½ | 2 | 7 | 14 |
| 5 | Coupling | inch | ½ | 1 | 7 | 7 |
| 6 | Fiber | Pc | 1 | 1 | 5 | 5 |
| 7 | Faucet | inch | ½ | 1 | 30 | 30 |
| 8 | Flexible steel pipe | inch | ½ | 1 | 3 | 30 |
| 9 | Filter | no | 1 | 1 | 40 | 40 |
| 10 | Sand | no | spade | 3 | 6 | 18 |
| 11 | Gravel | no | spade | 3 | 7 | 21 |
| Total cost incurred | | | | | | 585 |

From the table above the costs to install barrel plastic grey water treatment technology for each house hold is very low and has no transportation cost for flushing toilets, floor washing, outdoor plant, Irrigation of gardens /flower/, machine washing /cloth washing/ based on residence willingness since it is

constructed at home. In addition to this there are no grey water treatment system costs for chemicals and disinfectants added.

❖ **Maintenance cost**

Home owners or barrel plastic grey water treatment technology users supervise automatically self maintaining without consulting plumber consultants. This shows that there is no maintenance cost fee for using barrel plastic grey water treatment technologies. It is maintained by washing sand and gravels once a month and the filter material a week using safe and potable water.

❖ **Public perception**

A major difficulty for implementation of grey water treatment is public perception that is people thinking as grey water recycling are unsafe or unhealthy. However identifying different possible socio-technical issues of grey water reuse as part of water demand management from question 15 the willingness's to reuse grey water using a manually barrel plastic grey water treatment technology revealed that public acceptance of grey water reuse for certain activities can be quite high. A vast majority of the respondents which is **96%** have willingness to reusing grey water using a piloting treatment technology for saving potable water.

The construction procedure of barrel plastic piloting grey water treatment technology is first install two barrels consecutively and connects these two barrels with flexible steel pipe. During this in the first barrel we have to use sieve material which is called filter as a primary treatment used as a screener to remove floating materials such as hairs, detergents and mucus. Secondly adding sand and gravel at the bottom of the first barrel from bottom to top respectively as secondary treatment and the sand and gravel materials must be washed before using as a treatment as shown the figure below step by step. During secondary treatment bacteria consume the organic parts of the grey water, bacteria and oxygen accomplished it. Secondary treatment removes settle able solids and suspended solids. After this treated grey water is generated or collected in to the second barrel we can easily use either opening the faucet or connecting flexible pipe from the second barrel for flushing toilets, floor washing, outdoor plant, Irrigation of gardens /flower/, machine washing /cloth washing/ etc. based on the community willingness.

Thirdly collect 28 liter of grey water from each house hold samples from residences of mass condominium houses. Out of 28 samples 19 liter from cloth washing, 6 liter from hand washing and 3 liter from showers and collect grey water about one litter from each household in order to approve the treatment quality of barrel plastic grey water treatment technology. Fourthly add these 28 liters in a wide bucket in order to mix the samples that collected from cloth washing, hand washing and showers and take 1 liter sample from the influent to check in the laboratory. Lastly add these 28 liters in to the first barrel from the top of the filter and staying 2 days as a detention time in order to take the effluent sample from the second barrel with same size of the influent which is 1 liter of grey water to test, know and compare the influent and effluent grey water quality of the parameters BOD₅, TS, TSS, TDS, TVS, COD, DO in mg/l and PH values.

Step 1 buying the barrel, filter and gravel from the market



Step 2 Drill the first barrel in one side and the cover at the top, and drill the second barrel in two sides at the bottom; assemble the fittings with the barrel and the filter as shown in the figure below





Step 3 Set and install the two barrel with flexible steel pipe and add the gravel and the sand at the bottom of the first barrel. The sand materials must be washed until it becomes clean before adding in to the barrel.



Set and install the two barrel with flexible steel pipe



The sand materials washed until it becomes clean before adding in to the barrel



Add the sand at the bottom of the first barrel



Add the gravel at the bottom of the first barrel



The first barrel is ready to store untreated grey water collect untreated grey water from cloth washing



Collect untreated grey water from hand washing

the collected untreated grey water



Add the collected untreated grey water until it fills the barrel



Take a sample of untreated grey water for laboratory test



After a 2-day detention time take treated grey water for laboratory test



Comparison of treated grey water and untreated grey water

Test and record the different parameters taking the influent and effluent grey water sample

5.6.2 Lab Test Results of Two-Barrel Plastic Grey Water Treatment Technology First Round

The main purpose of the present study is to demonstrate the benefits of grey water reuse using a barrel plastic grey water treatment technology for the existing condominium houses that can be tested in lab to know and to compare the influent and effluent grey water quality of the parameters BOD₅, TS, TSS, TDS, TVS, COD, DO in mg/l and PH values.

COD (Chemical Oxygen Demand) is said to be the most general parameter to measure organic pollution. COD describes how much oxygen is required to oxidize all organic and inorganic matter found in the

wastewater sample. BOD (Biological oxygen demand) describes what can be oxidized biologically, with the help of bacteria and is always a fraction of COD. Usually BOD is measured as BOD₅ meaning that it describes the amount of oxygen consumed over a five-day measurement period. It is a direct measurement of the amount of oxygen consumed by organisms removing the organic matter in the waste (Kavitha, 2012).

SS (Suspended Solids) describes how much of the organic or inorganic matter is not dissolved in water and contains settle able solids that sinks to the bottom in a short time and non-settle able suspended solids. It is an important parameter because SS causes turbidity in the water causing clogging of filters etc. Total solids are the term applied to the material residue left in the vessel after evaporation of a sample and its subsequent drying in an oven at a defined temperature. Total solids include total suspended solids (the portion of total solids retained by a filter) and total dissolved solids (the portion that passes through the filter. Dissolved oxygen (DO) is the amount of oxygen dissolved in water and most aquatic organisms need oxygen to survive and grow (Kavitha, 2012).

PH is a measure of how acidic or basic (alkaline) a solution is. In any given solution some atoms of water dissociate to form hydrogen ions (H⁺) and hydroxyl ions (OH⁻).the PH scale is a means of showing which ion has the greater concentration. At a PH of 7.0, the concentration of hydrogen ions and hydroxyl ions are equal, and the water is said to be neutral. Pure water has a PH of 7.0.When the PH is less than 7.0, the water is said to be acidic. When the PH is greater than 7.0, the water is said to be basic. PH is defined as the negative logarithm of the hydrogen ion concentration.

$$PH = -\log (H^+)$$

The PH of most raw water lies within the range 6.5–8.5. The optimum pH will vary in different supplies according to the composition of the water and the nature of the construction materials used in the distribution system, but it is often in the range 6.5–9.5 (WHO, 1996). From Kaloty treatment plant laboratory report the BOD₅, TS, TSS, TDS, TVS, COD, DO in mg/l and PH value of influent and Effluent is represented in the table below.

Table 16: Effluent and Influent Quality from 2- Barrel System
(Collecting 28 Households).

| S.No | Parameters | Unit | Influent | Effluent |
|------|--|------|----------|----------|
| 1 | Biological oxygen demand (BOD ₅) | mg/l | 419.58 | 79.35 |
| 2 | PH | mg/l | 9.7 | 7.44 |
| 3 | Total solid (TS) | mg/l | 3350 | 767 |
| 4 | Total suspended solid (TSS) | mg/l | 220* | 100 |
| 5 | Total dissolved solids (TDS) | mg/l | 3130 | 667 |
| 6 | Total volatile solid (TVS) | mg/l | 2650 | 333 |
| 7 | Chemical oxygen demand (COD) | mg/l | 780* | 522 |
| 8 | Dissolved oxygen (DO) | mg/l | 1.95* | 3.13 |

* Shows that the influent sample of dissolved oxygen is difficult to easily settle and dissolved by

H₂SO₄, the influent sample of total suspended solid is difficult to easily filter and the influent sample of chemical oxygen demand difficult to easily titrate with standard ferrous ammonium sulfate. The main reason for these difficulties is that the grey water forms a complex bond since it contains hair, fat, oil, grease, mucus, soap and detergent residue.

NB: The lab test results of two-barrel plastic grey water treatment technology calculation of influent and effluent grey water quality of the parameters BOD₅, TS, TSS, TDS, TVS, COD, DO in mg/l and PH values in the first and second round is shown in **Appendix B**.

Table 17: The Standards Which Shall be Applied to all Effluents Discharge to Inland Waters

| S.No | Parameters | Unit | Emission limit value |
|------|--|-------|----------------------|
| 1 | Biological oxygen demand (BOD ₅) | mg/l | 80 |
| 2 | PH | units | 6-9 |
| 3 | Total solid (TS) | mg/l | 3100 |
| 4 | Total suspended solid (TSS) | mg/l | 100 |
| 5 | Total dissolved solids (TDS) | mg/l | 3000 |
| 6 | Total volatile solid (TVS) | mg/l | - |
| 7 | Chemical oxygen demand (COD) | mg/l | 250 |
| 8 | Dissolved oxygen (DO) | mg/l | - |

(Source Addis Ababa water and sewerage authority)

Table 18: The Greye Water Standards Which Shall be Reuse the Effluents to Indoor and Outdoor

| S.No | Parameters | Unit | Emission limit value | Use (suitable criteria) |
|------|--|-------|--------------------------|---|
| 1 | Biological oxygen demand (BOD ₅) | mg/l | 76-200 ^A | For toilet flushing, gardening, irrigation, car washing and fire fighting |
| 2 | PH | units | 5-8.1 ^A | |
| 3 | Total solid (TS) | mg/l | 3150 ^C | |
| 4 | Total suspended solid (TSS) | mg/l | 70-150 ^C | |
| 5 | Total dissolved solids (TDS) | mg/l | 3000 ^C | |
| 6 | Total volatile solid (TVS) | mg/l | 212.4-487.5 ^D | |
| 7 | Chemical oxygen demand (COD) | mg/l | 56-890 ^B | |
| 8 | Dissolved oxygen (DO) | mg/l | 2-4 ^E | |

A = (Antoine, 2005), B = (Alvin, 2009), C = (LLDA, 2013), D = (Sans, 2013), E = (TCEQ, June 16, 2006). Where LLDA=Laguna Lake Development Authority., TCEQ = Texas Commission on Environmental Quality

5.6.3 Lab Test results of Two-Barrel Plastic Grey Water Treatment Technology Second Round

The construction procedure of barrel plastic piloting grey water treatment technology is the same as the first round test. Whereas the collection of the sample in the second round is different. That is in the second round collecting 31 liter of grey water from each household about one liter from each household in order to approve the treatment quality of two- barrel plastic grey water treatment technology. Out of 31 samples 14 liter from cloth washing, 7 liter from hand washing and 10 liter from showers. From Kality treatment plant laboratory report the BOD₅, TS, TSS, TDS, TVS, COD, DO in

mg/l and PH value of influent and Effluent is represented in the table below.

Table 19: Effluent and Influent Quality from 2- Barrel System (collecting 31 Households).

| S.No | Parameters | Unit | Influent | Effluent |
|------|--|------|----------|----------|
| 1 | Biological oxygen demand (BOD ₅) | mg/l | 200.75 | 167.83 |
| 2 | PH | - | 7.86 | 6.47 |
| 3 | Total solid (TS) | mg/l | 1150 | 650 |
| 4 | Total suspended solid (TSS) | mg/l | 330 | 150 |
| 5 | Total dissolved solids (TDS) | mg/l | 820 | 500 |
| 6 | Total volatile solid (TVS) | mg/l | 650 | 200 |
| 7 | Chemical oxygen demand (COD) | mg/l | 682 | 486 |
| 8 | Disolved oxygen (DO) | mg/l | 2.15 | 3.79 |

Table 20: Summary of the Effluent and Influent Quality Average Result from 2- Barrel System

| S. No | Parameters | Unit | Average Influent | Average Effluent | Av.Influent- Av Effluent | % decreased from influent to effluent by using 2-barrel |
|-------|--|------|------------------|------------------|--------------------------|---|
| 1 | Biological oxygen demand (BOD ₅) | mg/l | 310.165 | 123.59 | 186.575 | 60.15 |
| 2 | PH | - | 8.78 | 6.955 | 1.825 | 20.86 |
| 3 | Total solid (TS) | mg/l | 2250 | 708.5 | 1541.5 | 68.5 |
| 4 | Total suspended solid (TSS) | mg/l | 275 | 125 | 150 | 54.55 |
| 5 | Total dissolved solids (TDS) | mg/l | 1975 | 583.5 | 1391.5 | 70.45 |
| 6 | Total volatile solid (TVS) | mg/l | 1650 | 266.5 | 1383.5 | 83.85 |
| 7 | Chemical oxygen demand (COD) | mg/l | 731 | 504 | 227 | 31.05 |
| 8 | Dissolved oxygen (DO) | mg/l | 2.05 | 2.64 | 0.59 | 28.78 |

Considering from table 20 above the grey water standard for eight specific parameters the study showed that, the two-barrel plastic grey water treatment technology is effective for treating the grey water and can be used in old condominium houses as a supporting piloting technology for toilet flushing, gardening, irrigation, car washing and fire fighting . The average value of treated effluent of BOD₅ in two-barrel plastic grey water treatment technology is 123.59 mg/l that treats 60.15% , the average value of treated effluent of PH is 6.955 that treats 20.86% , the average value of treated effluent of TS is 708.5 mg/l that treats 68.5% , the average value of treated effluent of TSS is 125 mg/l

that treats 54.55% , the average value of treated effluent of TDS is 583.5 mg/l that treats 70.45%, the average value of treated effluent of TVS is 266.5 mg/l that treats 83.85 % , the average value of treated effluent of COD is 504 mg/l that treats 31.05% and the average value of treated effluent of DO 2.64 mg/l that treats 28.78. The results obtained from BOD5, TS, TSS, TDS, TVS, COD and DO analysis showed that the average reduction of 186.575 ,1541.5, 150, 1391.5, 1383.5, 227 and 0.59 mg/l respectively. Whereas the PH values is changed from basic condition which is 8.78 to neutral condition which is 6.955.

CHAPTER SIX

6. Selection of Technologies for Grey Water Treatment and System Designs

6.1 Internal Sanitary Design

6.1.1 Separate design of Grey Water and Black Water Riser Diagram

Separation of grey water and black water is achieved through separate plumbing; the grey water and black water led through the house hold in separate sewage systems making a separate treatment possible as shown in the figure below.

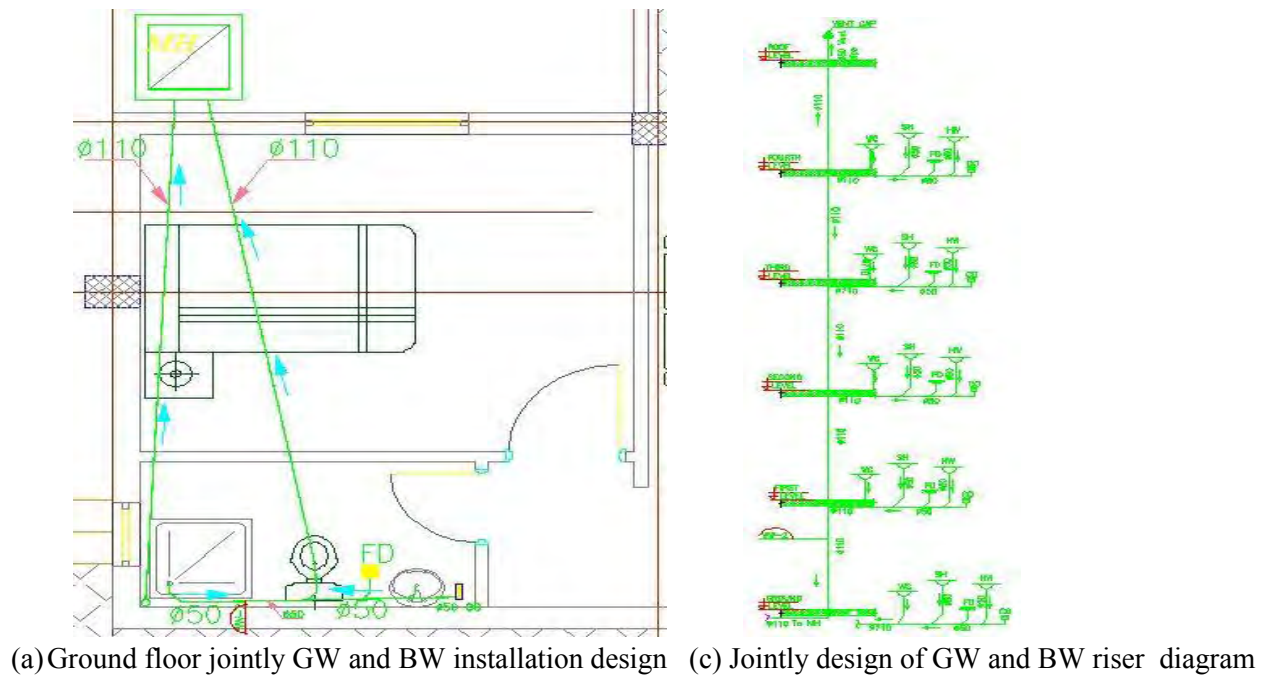
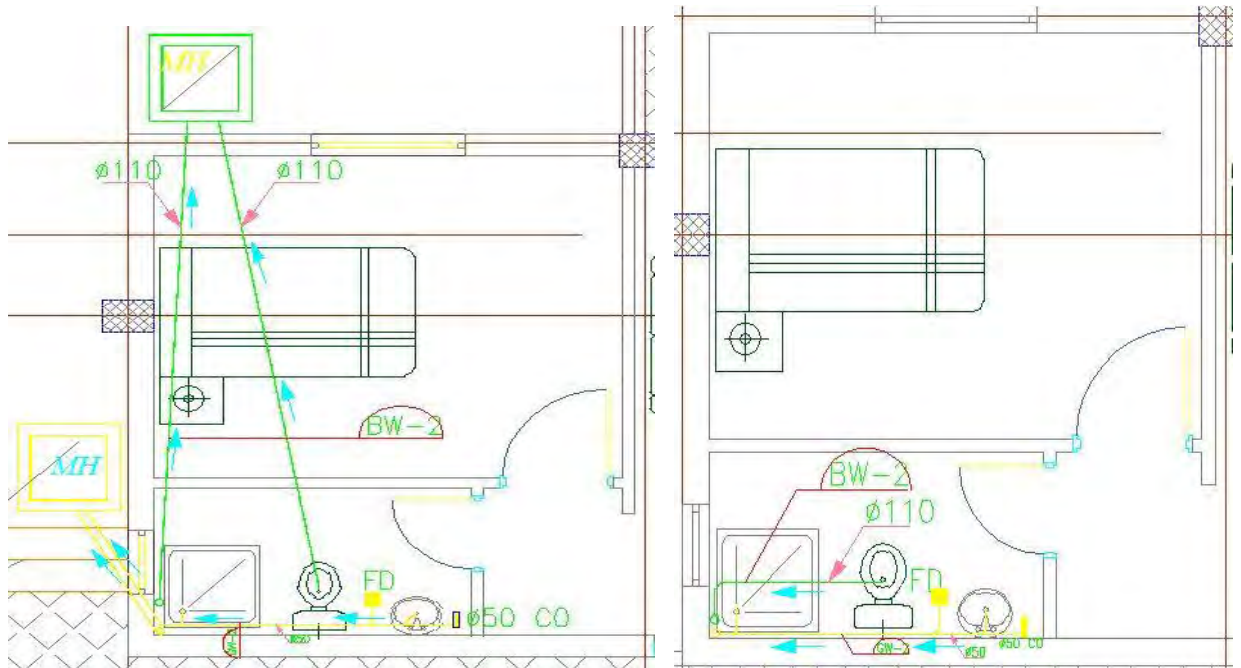

Figure 37: Existing Waste Water Design
(Refer Appendix –F- No. 1 in detail)



(a) Ground floor GW and BW separate sanitary installation design (b) Typical floor GW and BW separate sanitary installation design



(c) Black water riser diagram

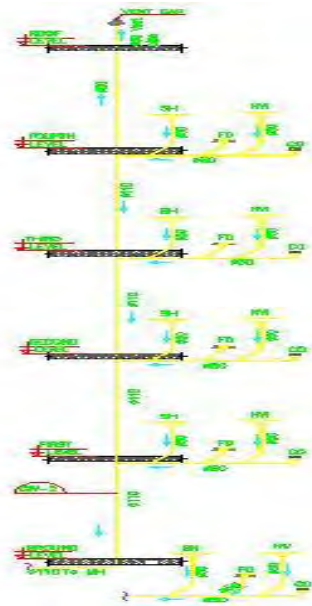

(d) Grey water riser diagram

Figure 38 : Separate Design of Grey Water and Black Water
(Refer **Appendix -F- No. 2** in detail)

6.1.2 Water Supply Riser Diagram Design and Installation

Supplying potable water for buildings is achieved through directly supplying potable water for both fixtures and additional water meter is installed to replace potable water with grey water to flush toilets to increase water efficiency. Meaning that for a grey water system to work properly first connect a valve municipal potable water sources to the system this will a guarantee that water will always be available when grey water production is insufficient as shown in the drawing below. Using this system design reduces fresh water in buildings, reduces water bills, grey water recycling is not dependent on season or variability of rain fall and as such recycling grey water for toilet flushing is a continuous and a reliable water resource.

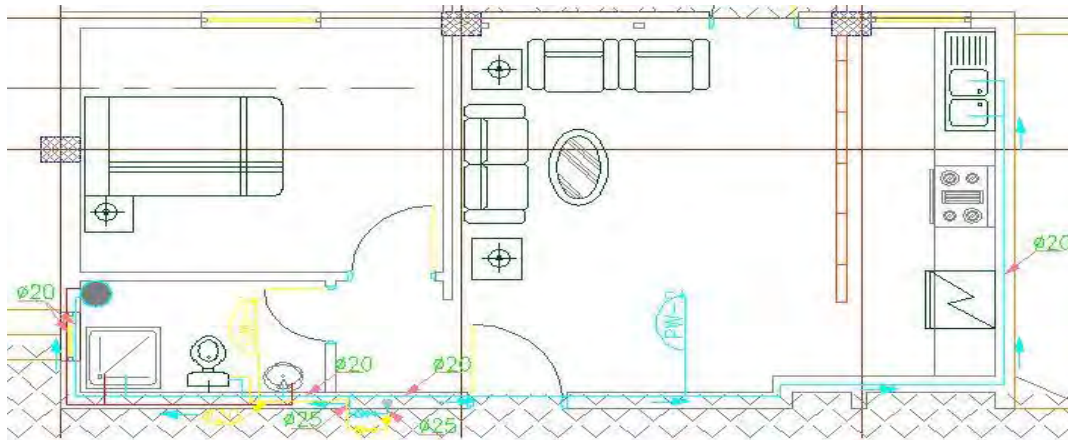

(a) Ground floor additional GW and PW supply installation

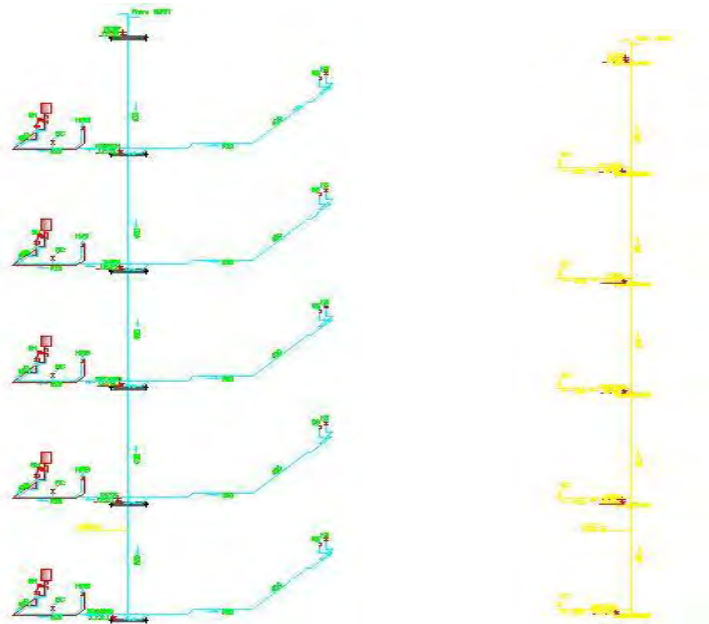

(b) Existing potable water supply riser diagram (c) Additional grey water supply riser diagram

Figure 39 : Existing Potable Water and Additional Grey Water Supply Design

(Refer **Appendix –F-** No. 3 in detail)

6.1.3 Cost Comparisons of Separate Design and Jointly Designing Grey Water and Black Water

The cost effectiveness of grey water recycling depend on the material cost, the amount of money we save (volume of potable water saved), waste water plant service saving and human satisfaction.

6.1.3.1 Potable Water Saving Potential

Grey water reuse leads to increase water use by saving money which is calculated an average saving of 376 m³/day out of the total maximum daily demand of potable water required in Jemo Gara condominium houses required (1426.59 m³/day) which is saving 26.4 % of total maximum daily demand of potable water required in Jemo Gara. Addis Ababa water and sewerage authority spends 1dollar for 1 m³ of water for treatment. Therefore in Jemogara condominium houses Addis Ababa water and sewerage authority saves 8272 ETB per day, 248160 ETB per month and 2977920 ETB per year using grey water recycling. In addition to potable water saving the community that lives in Jemo Gara condominium site saves their expenses from the water bills.

6.1.3.2 Material Cost

The study shows the comparative cost analysis of various sanitary installation fixtures (hand wash basins, water closets, showers, kitchen sink) and potable water supply pipes. The cost of fixtures for separate design of grey water and black water design is the same as the previous combined design of grey water and black water; whereas the initial cost of potable water supply and waste water (black water and grey water) riser pipes are vary. Referring figure 40, figure 41and figure 42 from the drawing above; the study design without separate plumbing (existing design) for potable water supply, the additional pipe required to supply the grey water for toilet flushing (separate design) and the separate disposal of black water and grey water is estimated in the table below.

Table 21: Comparison of Water Supply PPR Pipes in One Block in Jemo Gara

| Material | Without separate plumbing | | | | Additional pipe required to supply grey water for toilet flushing | | | | % Increment | |
|--------------------|---------------------------|--------|------------|------------------|---|--------|------------|--------------|----------------|--------------|
| | unit | Qty | Rate (ETB) | Amount (ETB) | unit | Qty | Rate (ETB) | Amount (ETB) | | |
| Supply PPR pipes | | | | | | | | | | |
| Dia 20mm | ml | 761.55 | 16 | 12184.8 | ml | 237 | 16 | 3792 | | |
| Dia 25mm | ml | 72.66 | 21 | 1525.86 | ml | 180.67 | 21 | 3794.04 | | |
| Dia 32mm | ml | 108.01 | 31.50 | 3402.315 | ml | | 31.50 | | | |
| Total (ETB) | | | | 17112.975 | | | | | 7586.04 | 44.33 |

Table 22: Comparison of Supplying PPR pipes in 46 Blocks in Jemo Gara

| Material | Without Separate Plumbing | | | | Additional Pipe Required to Supply Grey Water | | | | % Increment | AAWSA Saving Money Using Grey Water Recycling per Year (ETB) | Cost Recovery period (Yrs) | |
|--------------------|---------------------------|---------|------------|------------------|---|---------|------------|--------------|------------------|--|----------------------------|------------------|
| | unit | Qty | Rate (ETB) | Amount (ETB) | unit | Qty | Rate (ETB) | Amount (ETB) | | | | |
| Supply PPR pipes | | | | | | | | | | | | |
| Dia 20mm | ml | 35031.3 | 16 | 560500.8 | ml | 10902 | 16 | 174432 | | | | |
| Dia 25mm | ml | 3342.36 | 21 | 70189.56 | ml | 8310.82 | 21 | 174527.22 | | | | |
| Dia 32mm | ml | 4968.46 | 31.50 | 156506.49 | ml | | 31.50 | | | | | |
| Total (ETB) | | | | 787196.85 | | | | | 348959.22 | 44.33 | 2977920 | 1.4 month |

Table 23: Comparison of Black Water and Grey Water Riser Pipes in One Block in Jemo Gara

| Material | Black water | | | | Additional PVC Pipe Required for Grey Water riser | | | | % Increment | |
|--------------------|-------------|-------|------------|------------------|---|-------|------------|--------------|----------------|--------------|
| | unit | Qty | Rate (ETB) | Amount (ETB) | unit | Qty | Rate (ETB) | Amount (ETB) | | |
| Supply PVC pipes | | | | | | | | | | |
| Dia 50mm | ml | | 52.5 | | ml | 109.9 | 52.5 | 5769.75 | | |
| Dia 75mm | ml | 109.9 | 101.49 | 11153.751 | ml | | 101.49 | | | |
| Dia 110mm | ml | 109.9 | 192.50 | 21155.75 | ml | | 192.50 | | | |
| Total (ETB) | | | | 32309.501 | | | | | 5769.75 | 17.86 |

Table 24: Comparison of Black Water and Grey Water Riser Pipes in 46 Blocks in Jemo Gara

| Material | Without Separate Plumbing | | | | Additional Pipe Required to Supply Grey Water | | | | % Increment | AAWSA Saving Money Using Grey Water Recycling per Year (ETB) | Cost Recovery period (Yrs) | |
|--------------------|---------------------------|--------|------------|-------------------|---|--------|------------|--------------|-------------|--|----------------------------|-------------------|
| | unit | Qty | Rate (ETB) | Amount (ETB) | unit | Qty | Rate (ETB) | Amount (ETB) | | | | |
| Supply PVC pipes | | | | | | | | | | | | |
| Dia 50mm | ml | | 52.5 | | ml | 5055.4 | 52.5 | 265408.5 | | | | |
| Dia 75mm | ml | 5055.4 | 101.49 | 513072.55 | ml | | 101.49 | | | | | |
| Dia 110mm | ml | 5055.4 | 192.50 | 973164.5 | ml | | 192.50 | | | | | |
| Total (ETB) | | | | 1486237.05 | | | | | 265408.5 | 27.77 | 2977920 | 1.07 month |

Table 25: Material Cost Comparison Summary of Separate Design of Grey Water and Black Water

| Number of blocks | Material cost | | % Increment | AAWSA saving money using grey water recycling per year (ETB) | Cost recovery period (Yrs) |
|------------------|---------------------------|--------------------------|-------------|--|----------------------------|
| | Without separate plumbing | Additional cost required | | | |
| 46 | 2,273,433.90 | 614,367.72 | 27 | 2977920 | 2.48 month (Take 3 month) |

From the benefit cost analysis as shown in the table above Addis Ababa water and sewerage authority saves 2,977,920 ETB per year using grey water recycling in Jemo Gara condominium site and 884,755,872 ETB per year using grey water recycling from future construction condominium housing sites (111,711.6 m³/day) with a three month cost recovery period and 236,324,880 ETB per year from existing condominium sites (29,839 m³/day) without cost recovery period by using a 2-barrel piloting treatment technology.

6.1.3.3 Waste Water Treatment Plant Service Saving

Since the waste water sent to the sewer in centralized system there is a need of expansion of the capacity of the centralized waste water treatment plant. However using decentralized grey water treatment plant reduces the demands on the sewer and there is an additional benefit of reducing pipe sizes from the site to the centralized waste water treatment plant.

6.1.3.4 Human Satisfaction

The human satisfaction benefit cost ratio is very high and poverty is not a barrier to reasonable access to get clean water. In Addis Ababa city; Addis Ababa water and sewerage authority costs 1 dollar for treating 1 m³ of water. In contrast to this the authority sold 1 m³ of water with 1.75 ETB taking the human satisfaction in to consideration.

6.2 Selection of Grey Water Treatment Technologies

This study has been elaborated for the comparative analysis of various available waste water treatment technologies, for the accommodation of the population in Jemo Gara condominium houses.

6.2.1 Comparative Analysis of Various Available Grey Water Treatment Technologies

The most commonly grey water treatment technologies that are found from interview results and in different literature which were described in literature review that will be applied for Jemo Gara condominium houses as a demonstrator for future plan construction condominium houses are conventional activated sludge system (CAS), extended aeration activated sludge system (EAAS), sequential batch reactor system (SBR), trickling filters (TF), rotating biological contactor system (RBC), stabilization ponds, moving bed biological reactor (MBBR) and membrane bio-reactors (MBR).

6.2.2 Comparison of the Alternative Options

The comparison (methods chosen) of the alternative treatment processes could be incorporates a variety of approaches on the basis of quality of the grey water to be treated, land space required for construction, protection of the environment (the public health), personnel skills required, the familiarity of the technology in the city and the relative investment and running costs of the above treatment technologies for reusing of grey water for mass condominium houses. So, in this study the implementation of a Multi-Criteria Analysis (MCA) would be the appropriate method for the all-embracing comparison of the alternative treatment options.

A standard feature of MCA is the “performance or evaluation matrix” (referred to as “matrix”) in which each column describes a “treatment option” (technology) and each row describes a “criterion” against which the performance of each option is evaluated. Such a matrix is developed for the evaluation of the alternative treatment options under consideration. In order to assess “the performance of each options for the set of the developed criteria numerical scoring is applied with a scale 10 to 30, 30 being the maximum point to allow the importance of the criteria to be differentiated and it is selected based on the researchers feeling. Scores are summarized with weighting factors and summed up to give a total score. The MCA approach that applies scoring and weighing is a compensatory MCA technique since low scores on one criterion may be compensated by high scores on another.

6.2.2.1 Comparison Criteria

The comparison criteria to compare the above treatment technologies presented in the following considerations like:

1. Quality of the grey water to be treated,
2. Land space required for construction,
3. Protection of the environment (the public health) and odor nuisance
4. Relative investment and running costs
5. Personnel skills required
6. Familiarity of the technology in the city

These criteria and their weights were selected based on the result on chapter five identify different possible socio-technical issues of grey water reuse as part of water demand management in section 5.4 interview results from Jemo Gara condominium housing construction supervision professional engineers and interview results from Addis Ababa water and sewerage authority managers section 5.5 based on the considerations to be under taken for the selection of grey water technologies from supervision professional engineers and Addis Ababa water and sewerage authority managers summary table in section 5.5. For the purpose of this generic evaluation the criteria and their weights are presented in the table below.

Table 26: Comparison Matrix (Criteria and Weight factors)

| No | Criteria | Criteria weighting factor |
|-------|---|---------------------------|
| 1 | Quality of the grey water to be treated, | 10% |
| 2 | Land space required for construction | 15% |
| 3 | Protection of the environment (the public health) and odor nuisance | 10% |
| 4 | Relative investment and running costs | 30% |
| 5 | Personnel skills required | 20 |
| 6 | Familiarity of the technology in the city | 15 |
| Total | | 100% |

The comparison for the various criteria's are presented as follows.

6.2.2.1.1 Comparison for Quality of the Grey Water to be Treated

Table 27: Comparison of the Alternative Process Option for Quality of the Grey Water

| No | Criteria | Criteria weighting factor | CAS | EAAS | SBR | TF | RBC | WSP | MBBR | MBR |
|----|---|---------------------------|----------------|----------------|----------------|----------------|----------------|----------------|----------------|----------------|
| | | | Weighted score | Weighted score | Weighted score | Weighted score | Weighted score | Weighted score | Weighted score | Weighted score |
| 1 | Quality of the grey water to be treated | 10% | 6 | 5 | 9 | 4 | 3 | 7 | 8 | 10 |

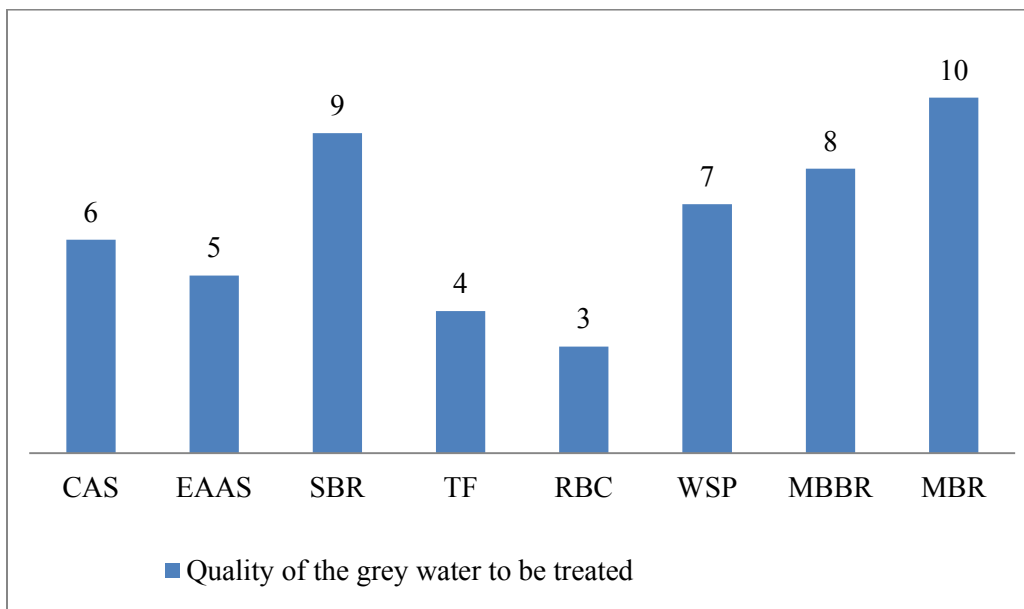

Figure 40: Ranking the Alternative Technologies Based on the Quality of the Grey Water

As presented above the most appropriate treatment method of technology considering the quality of the grey water to be treated is MBR and second in place comes SBR. Again RBC and TF systems found at the bottom of the ranking, due to low effluent quality.

6.2.2.1.2 Comparison for Land Space Required for Construction

Table 28: Comparison of the Alternative Process Option for Land Space Required

| No | Criteria | Criteria weighting factor | CAS | EAAS | SBR | TF | RBC | WSP | MBBR | MBR |
|----|--------------------------------------|---------------------------|----------------|----------------|----------------|----------------|----------------|----------------|----------------|----------------|
| | | | Weighted score | Weighted score | Weighted score | Weighted score | Weighted score | Weighted score | Weighted score | Weighted score |
| 2 | Land space required for construction | 15% | 10 | 9 | 11 | 12 | 13 | 8 | 14 | 15 |

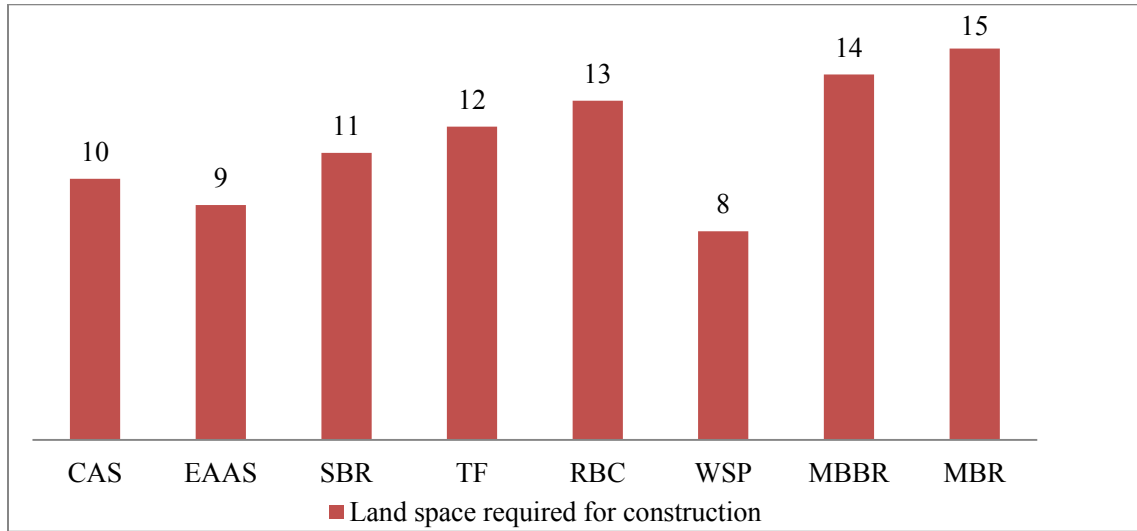

Figure 41 : Ranking the Alternative Technologies Based on the Land Required for Construction

As presented above the most appropriate treatment method of technology considering low land space required for construction is MBR which has high scores and the second higher score in place comes MBBR. Again WSP and EAAS systems found at the bottom of the ranking, due to higher land requirement.

6.2.2.1.3 Comparison for Protection of the Environment and Odor Nuisance

Table 29: Comparison of the Alternative Process Option for odor nuisance

| No | Criteria | Criteria weighting factor | CAS | EAAS | SBR | TF | RBC | WSP | MBBR | MBR |
|----|---|---------------------------|----------------|----------------|----------------|----------------|----------------|----------------|----------------|----------------|
| | | | Weighted score | Weighted score | Weighted score | Weighted score | Weighted Score | Weighted score | Weighted score | Weighted score |
| 3 | Protection of the environment (the public health) and odor nuisance | 10% | 6 | 7 | 8 | 4 | 5 | 3 | 9 | 10 |

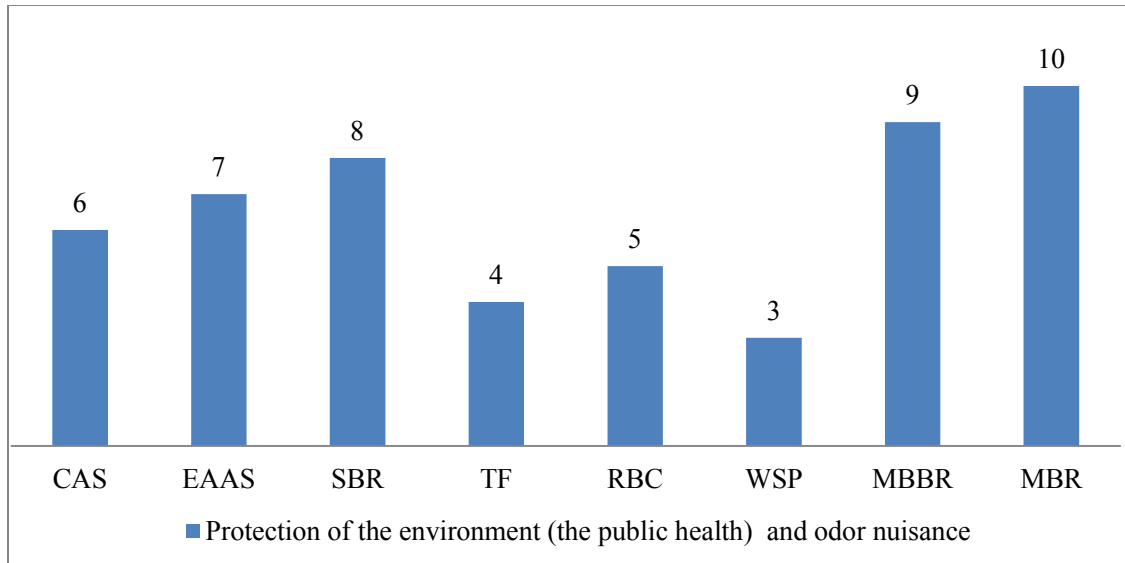

Figure 42 : Ranking the Alternative Technologies Based on the Odor Nuisance

As presented above the most appropriate treatment method of technology based on the protection of the environment (the public health) and odor nuisance is MBR and second in place comes MBBR. Again WSP and TF systems found at the bottom of the ranking, due to higher influence based on the protection of the environment (the public health) and odor nuisance.

6.2.2.1.4 Comparison for Relative Investment and Running Costs

Table 30: Comparison of the Alternative Process Option for Running Costs

| No | Criteria | Criteria weighting factor | CAS | EAAS | SBR | TF | RBC | WSP | MBBR | MBR |
|----|---------------------------------------|---------------------------|----------------|----------------|----------------|----------------|----------------|----------------|----------------|----------------|
| | | | Weighted score | Weighted score | Weighted score | Weighted score | Weighted score | Weighted score | Weighted score | Weighted score |
| 4 | Relative investment and running costs | 30% | 26 | 26 | 27 | 28 | 29 | 30 | 25 | 24 |

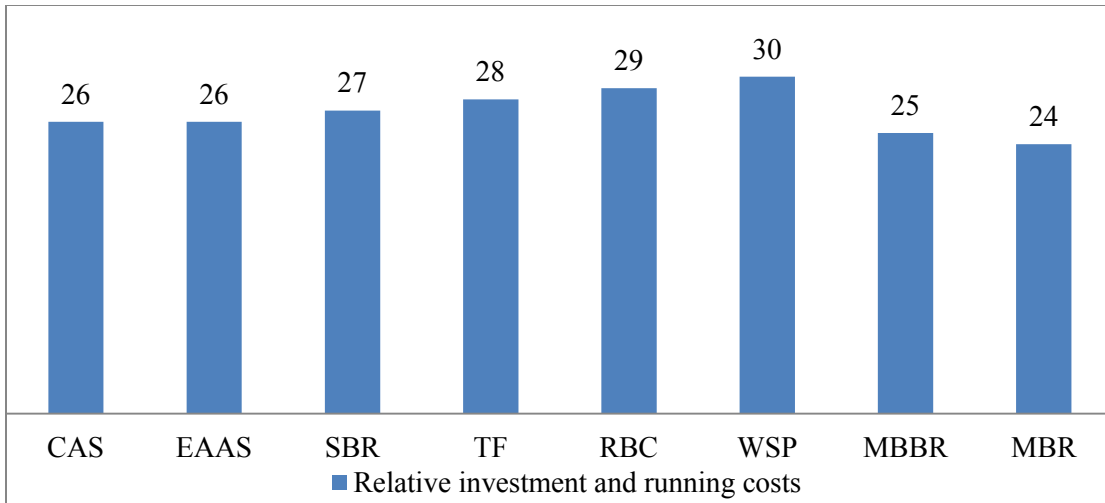

Figure 43 : Ranking the Alternative Technologies Based Costs

As presented above the most appropriate treatment method of technology based on the relative investment and running costs is WSP and second in place comes RBC. Again MBR and MBBR systems found at the bottom of the ranking, due to higher investment and running costs.

6.2.2.1.5 Comparison for Personnel Skills Required

Table 31: Comparison of the Alternative Process Option for Personnel Skills Required

| No | Criteria | Criteria weighting factor | CAS | EAAS | SBR | TF | RBC | WSP | MBBR | MBR |
|----|---------------------------|---------------------------|----------------|----------------|----------------|----------------|----------------|----------------|----------------|----------------|
| | | | Weighted score | Weighted score | Weighted score | Weighted score | Weighted score | Weighted score | Weighted score | Weighted score |
| 5 | Personnel skills required | 20% | 17 | 18 | 14 | 15 | 16 | 20 | 19 | 13 |

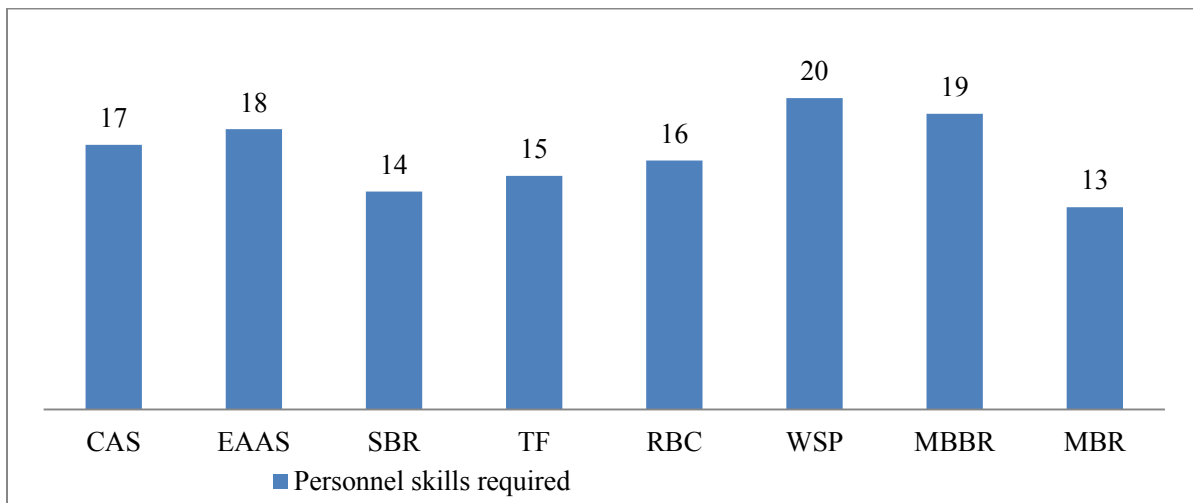

Figure 44 : Ranking the Alternative Technologies Based on the Personnel Skills Required

As presented above the most appropriate treatment method of technology based on the Personnel skills required is WSP and second in place comes MBBR. Again MBR and SBR systems found at the bottom of the ranking, due to higher personnel skills required.

6.2.2.1.6 Comparison for familiarity of the technology in the city

Table 32: Comparison of the Alternative Process Option for Familiarity of the Technology

| No | Criteria | Criteria weighting factor | CAS | EAAS | SBR | TF | RBC | WSP | MBBR | MBR |
|----|---|---------------------------|----------------|----------------|----------------|----------------|----------------|----------------|----------------|----------------|
| | | | Weighted score | Weighted score | Weighted score | Weighted score | Weighted score | Weighted score | Weighted score | Weighted score |
| 6 | Familiarity of the technology in the city | 15% | 14 | 14 | 7.5 | 8 | 7.5 | 15 | 7.5 | 14 |

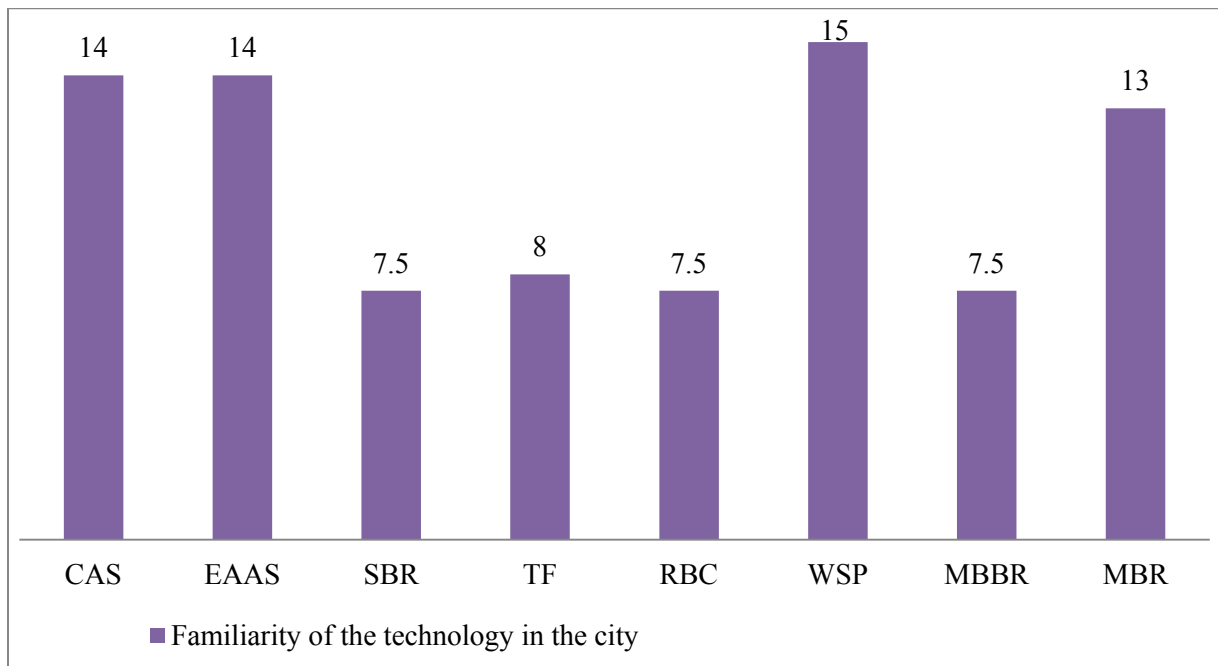

Figure 45: Ranking the Alternative Technologies Based on the Familiarity of the Technology

As presented above the most appropriate treatment method of technology based on the familiarity of the technology in the city is WSP and second in place comes CAS and EAAS. Again SBR, RBC, MBBR and MBR systems found at the bottom of the ranking, due to unfamiliarity of the technology in the city.

Table 33: Summary of Scores from the Comparison of Different Alternative Options

| No | Criteria | Criteria weighting factor | CAS | EAAS | SBR | TF | RBC | WSP | MBBR | MBR |
|-------|----------|---------------------------|----------------|----------------|----------------|----------------|----------------|----------------|----------------|----------------|
| | | | Weighted score | Weighted score | Weighted score | Weighted score | Weighted score | Weighted score | Weighted score | Weighted score |
| 1 | 1* | 10% | 6 | 5 | 9 | 4 | 3 | 7 | 8 | 10 |
| 2 | 2* | 15% | 10 | 9 | 11 | 12 | 13 | 8 | 14 | 15 |
| 3 | 3* | 10% | 6 | 7 | 8 | 4 | 5 | 3 | 9 | 10 |
| 4 | 4* | 30% | 26 | 26 | 27 | 28 | 29 | 30 | 25 | 24 |
| 5 | 5* | 20% | 17 | 18 | 14 | 15 | 16 | 20 | 19 | 13 |
| 6 | 6* | 15% | 14 | 14 | 7.5 | 8 | 7.5 | 15 | 7.5 | 13 |
| Total | | 100% | 79 | 79 | 76.5 | 71 | 73.5 | 83 | 82.5 | 79.5 |

- 1*= Quality of the grey water to be treated
- 2*= Land space required for construction
- 3*= Protection of the environment (the public health) and odor nuisance
- 4*= Relative investment and running costs
- 5*= Personnel skills required
- 6*= Familiarity of the technology in the city

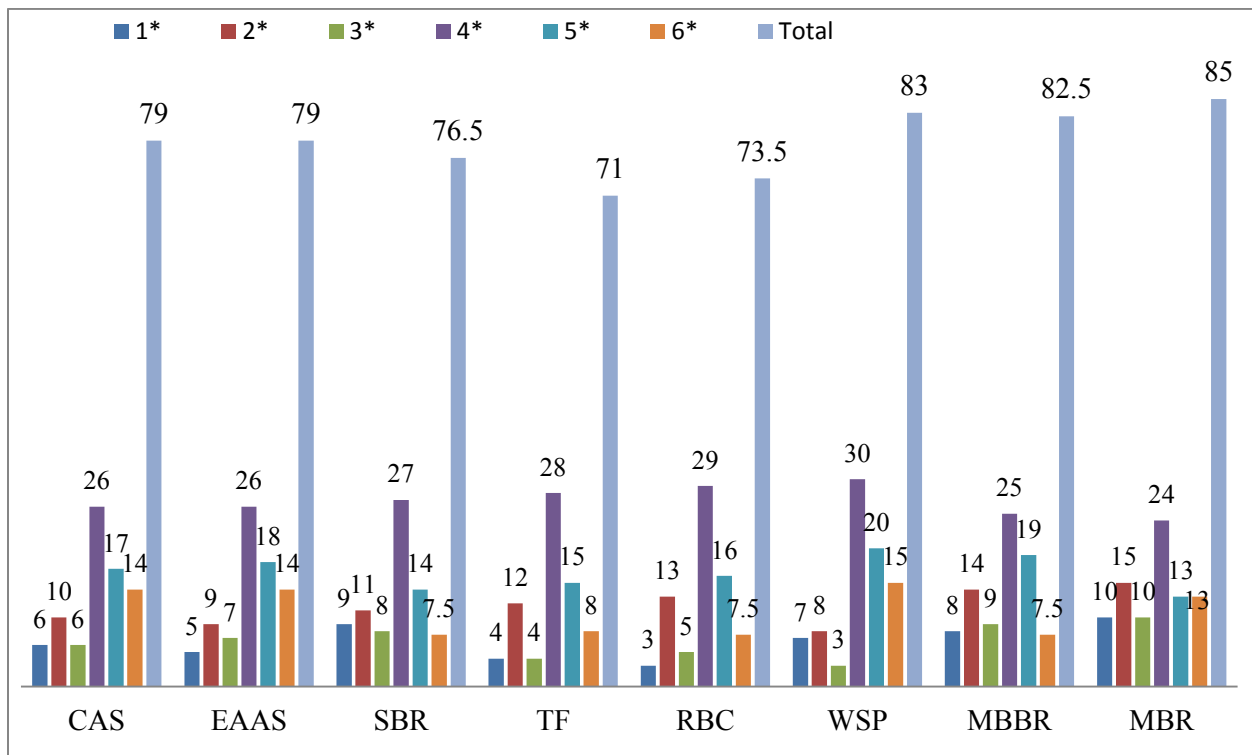

Figure 46 : Summaries Scores from the Comparison of the Alternative Treatment Technologies

Based on the six comparison criteria assumptions the study reflects the best possible treatment technology from the evaluation of the treatment option is WSP and second in place comes MBBR systems. Again TF

and RBC systems found at the bottom of the ranking, due to these six comparison criteria assumption and evaluation.

From the comparative selection of various available grey water treatment technologies above; It has to be noted that the comparative analysis of various available decentralized grey water treatment technologies were selected and compared based on an interview results and literature review as stated by the comparative criteria's and its weighting factor. Hence, the discussion of the findings from the selection of grey water treatment technologies is presented below.

- Regarding to achieve the required discharge all the selected decentralized grey water technologies are well proven.
- Concerning the availability of the technology all the selected decentralized grey water technologies are simple open source technologies which are produced by various manufacturers.
- Membrane bio-reactors has a significant positive alternative based on the protection of the environment (the public health) and odor nuisance where as waste stabilization pond has a negative significant concerning the protection of the environment (the public health) and odor nuisance.
- Regarding the quality of the grey water to be treated membrane bio-reactors has a significant positive alternative due to higher effluent quality where as rotating biological contactor system has a negative significant due to lower effluent quality.
- Concerning the space required for construction waste stabilization pond systems have a negative significant due to higher land footprint requirement where as membrane bio-reactors has a positive significant due to lower land footprint requirement.
- Regarding the investment and running cost waste stabilization pond systems has a positive significant due to lower operational cost with very small energy consumption, local material usage, lack of chemical usage and minimal maintenance where as membrane bio-reactors grey water treatment technology has a negative significant due to higher investment and running cost of the membrane for high chemical consumption for cleaning and maintenance of the membranes.
- There is a very negative significant using membrane bio-reactors grey water treatment technology concerning the personnel skills required due to a need for high level of operator skill and monitoring where as waste stabilization pond systems has positive significance that requires very low personnel skills to operate and maintain the system facilities.
- Decentralized waste stabilization pond waste water treatment has a huge positive significant application currently used and familiar in the city; Mickey Leland and Gelan condominium houses are some of the decentralized waste stabilization pond waste water treatment users.

Limitation of the selection of grey water treatment technologies

- The comparative analysis of various available decentralized grey water treatment technologies were selected and compared based on an interview results and literature review only. According to this reason the research study has a limitation and needs detailed study for prioritizing and deciding the most important decentralized grey water technologies considering additional comparative criteria's.

CHAPTER SEVEN

7. Conclusion and Recommendation

7.1 Conclusions

This thesis investigate the water demand management of condominium houses considering grey water reuse and the available options which can be applied for the existing condominium house and future construction condominium houses under the existence of water shortage. The current development in the city increases the living standards dramatically and population growth will continue to be one of the most severe demand problems facing Addis Ababa water production. As a result Addis Ababa water and sewerage authority need more water options for those and the analysis has shown that to support the current water supply and water demand of the city

Some of the important, benefits and finding of water demand management of condominium houses considering grey water reuse is both to the consumer and the utility. These important, benefits and finding are successfully in the existing and future condominium houses. Greywater and black water **separation** with Membrane bio-reactors (MBR) and **2-barrel** piloting treatment technology are successfully implemented in the future and existing condominium houses. Generally greywater recycling support and contributes the gap between the water supply for the existing and future water demand of the city.

7.2 Recommendations

All the above results and findings of the research full fill the gap in the future water demand. In addition to this some deficiencies related to water demand management related to water demand management of condominium houses considering grey water reuse in order to improve and activate the current situation the following recommendation are suggested.

For new condominium houses Addis Ababa Housing Construction Project Office implemented separation of greywater, blackwater design and construction; and Addis Ababa Water and Sewerage Authority implemented decentralized treatment technologies.

Separation of grey water and black water is implementing in new condominium houses through separate plumbing using Membrane bio-reactors (MBR) decentralized treatment technology. To full fill the gap between the current water supply and water demand Addis Ababa water and sewerage authority and Addis Ababa housing construction project office must be cooperate to ensure the success of any future water demand management program; Addis Ababa water and sewerage authority put incentives for those who are implementing piloting treatment technology, constant public monitoring, understanding and awareness creation of the community with education.

The 2-barrel piloting grey water treatment technology requires substantial case as its effectiveness is highly affected by the care of family members. Thus users should regularly clean the filter material once a week and the sand and gravel once a month.

8. Reference

- AL-Beirut. and Shihab N. October 2004. Decentralized Wastewater Use for Urban Agriculture in Peri-Urban Areas. Jordan Palestine
- Alison S. 2013. An Investigation in to Public Perceptions of Water Recycling and Alternative water Management in Pretoria, South Africa:
- Aloyce W. Mayo, Emmanuel E. Hanai 2014. Dynamics of Nitrogen Transformation and Removal in a Pilot High Rate Pond, Journal of Water Resource and Protection 6, 433-445 Dar es Salaam, Tanzania <http://ww.scrip.org/journal/jwarp>
- Alvin L. November 2009. Investigation of Anaerobic up-Flow Batch Reactor for Treatment of Grey Water in un-Sewered Settlements, Cape Peninsula.
- Anthony F. May 2011. Quantifying the Benefits of Grey Water Systems in Georgia.
- Antoine February 2005. Grey Water Treatment on Household Level in Developing Countries, Zurich
- Aravidis A. September 2007. Water Demand Management and Water Conservation Potential and Limitations in Katerini, Greece
- Bell B. et al. (November 2010). Recommendations on Grey Water Treatment, Disposal and Reuse. DEQ (Department of Environmental Quality).
- Borkar R.P, Gulhane M.L, and Kotangale A.J, Dec 2013. Journal of Environmental Science, Moving Bed Biofilm Reactor-A New Perspective in Wastewater Treatment. Volume 6, PP 15-21, India.
- Cape Peninsula University of Technology (CPUT) Cape Town, South Africa 2006. Water Conservation and Water Demand Management: www.dlist-benguela.org
- Central Statistical Agency 2007-2037, July 2013. Population Projections for Ethiopia
- Daniel Vieira, Minegatti de, Oliveira, Marcio Dias Rabelo, Yuri Nascimento Nariyoshi 2014. Evaluation of a MBBR (moving bed biofilm reactor) Pilot Plant for Treatment of Pulp and Paper Mill Wastewater, International Journal of Environmental Monitoring and Analysis Vol. 2: p.220-225
- David B. 12 September 2005. An Operational Definition of Water Demand Management. Research Friends of the Earth Canada
- Delzer G. and Mckenize S., 2003. Five Day Biochemical Oxygen Demand. United State Geological Survey Third Edition.
- Edward E. 2000. Urban Water Systems: Demand Management and Sustainable Development
- Elberti T., September 2012. Membrane Bioreactors for Wastewater Treatment.
- Eng. Dr. Erich Kellner 2012. Wastewater Treatment Plants and Management, Brazil
- Friedler E. et al, 2005. On-site Grey Water Treatment and Reuse in Multi-storey Buildings. Article, vol 51 no 10 pp 187-194
- Gamsby and Manneraw January 2012. Screening-Level Assessment of Biological Treatment Alternatives.
- Igarashi, T., Watanabe, Y., Asno, T. and Tambo N. 1999: Water Environmental Engineering and Reuse of Water, Hokkaido, p.250-305
- Indian Institute of Technology Delhi, 2013. Measuring Chemical Oxygen Demand, India.
- Jafrudeen and Ahsan N., Nov 2012. International Journal of Advances in Engineering and Technology, Study of Widely Used Treatment Technologies for Hospital Waste Water and Their Comparative Analysis, India.
- Jefferson B. et al. 2004. Grey Water Characterization and its Impact on the Selection and Operation of Technologies for Urban Reuse Vol 50 No 2 pp 157-164, Sydney.

- Jefferson B., Pidou M., Ali F., Stephenson T., and Jeffrey P. 2004. Grey Water Recycling: A Review of Treatment Options and Applications, Institute of Civil Engineers Proceedings Engineering Sustainability. Vol.160, Page 119-131.
- Prashant A. Kadu, October 2012. International Journal of Engineering, A Review of Rotating Biological Contactor System, India. Vol.2, PP.2149-2153. www.ijera.com
- Kavitha R.V, Krishna V, Asith K, 2012. International Journal of Engineering Research and Applications (IJERA). Physico- Chemical Analysis of Effluents from Pharmaceutical Industry and its Efficiency Study. Vol.2, PP: 103-110. www.ijera.com
- Khume Bahadur 2014. Feasibility Study of Submerged Membrane Bioreactor as an Alternative to Conventional Activated Sludge Process, Lappeenranta.
- Kirsten 2004. A review of Water Reuse and Recycling. Vol 39, No.1, 13-28, Canada
- Laguna Lake Development Authority 2013. Provision of the Implementing Rules and Regulation of the Philippine
- Lambe S. and Chougule S. 2008. IOSR Journal of Mechanical and Civil Engineering (IOSR-JMCE) ISSN: 2278-1684. Grey water – Treatment and Reuse. Article, pp: 20-26
- Marie K. 2012. The Challenges to Implementing Decentralized Water Reuse: A Grey water Recirculation Case Study in Boulder, Colorado
- Marcos R.Vianna, Gilberto C.B.de Melo and Marcio R.V. Neto September 18, 2012. Journal of urban and environmental engineering (JUEE), Brazil. Vol.6, n.2, PP: 57-66
- Melvin G. August 17, 2014. Journal of Environment Pollution and Human Health, 2014, Vol. 2, No.3, PP: 58-62. <http://pubs.sciepub.com/jephh/2/3/1>
- Mengistu. (2010). Assessing Water Conservation and Demand Management Option for Addis Ababa city.
- Memon A. et al. (2007). Life Cycle Impact Assessment of Grey Water Recycling Technologies for New Developments. Article, Environ Monit Assess, 129:27–35, DOI 10.1007/s10661-006-9422-3, Vol 129, pp: 27-35
- M. Kermani, B. Bina, H. Movahedian, M.M. Amin and M. Nikaein, 2008. American Journal of Environmental Sciences 4 (6): 682-689,
- Musfique A., Meenakshi A. 2012. Sustainable Grey Water Recycling as Decentralized Alternative Water Supply Option for Integrated Urban Water Management. Vol 2, PP-31-35. Victoria, Australia.
- Nweze N, D.C. Anozie and B.o. Ude 2014. Performance Evaluation of a Tropical Modern Brewery Waste Stabilization Pond IOSR Journal Of Environmental Science, Toxicology And Food Technology (IOSR-JESTFT) e-ISSN: 2319-2402, p- ISSN: 2319-2399. Volume 8, Issue 2 Ver. PP 50-54 www.iosrjournals.org Nigeria
- Policy Study and Analysis Sub Process May 2013. Socio-Economic Profile of Addis Ababa, Ethiopia
- Sans C., 2013. Volatile Fatty Acids Production by Anaerobic Fermentation of Urban Organic Wastes, Barcelona. PP: 886-892.
- Schumacher B., 1989. Methods for Chemical and Physical Analysis. Vegas
- Simms J. 2006. Local Board of Health Guide to On-site Waste Water Treatment Systems. National Association of Local Board of Health. www.nalboh.org
- Steven E. Williams, P.E., January 2011. Reconsidering Rotating Biological Contactors as an Option for Municipal Wastewater Treatment, New York.
- Tewfik R. 2005. Water Demand Management in Gaza City

Technical Assistance Hydrology Project, 1999. How to Measure Dissolved, Suspended and Total Solids. New Delhi. E-Mail:dhvdeft@del2.vsnl.net.in

Texas Commission on Environmental Quality, June 16, 2006. Domestic Waste Water Effluent Limitation and Plant Siting. PP: 1-7.

The Regional Water Demand Initiative in the Middle East and North Africa (WaDI*mena*). (2011). HTTP://WWW.IDRC.CA/WADIMENA/EV-121555-201-1-DO_TOPIC.HTML

United Nations Human Settlements Programme (UN-HABITAT). The Integrated Housing Development Programme, Condominium Housing in Ethiopia, Nairobi Kenya: www.unhabitat.org/condominium

United States Environmental Protection Agency, 1999. Waste Water Technology Fact Sheet Sequencing Fact sheet, Sequencing Batch Reactors. Washington, D.C.

United States Environmental Protection Agency, September 2007 Wastewater Management Fact Sheet Membrane Bioreactors United States.

University of Zululand May 2003. Handbook for the Assessment of Catchment Water Demand and Use. <http://www.hrwallingford.co.uk>

Wastewater Operator Certification (WOC) December 2013. Introduction to Ponds, Lagoons, and Natural Systems Study Washington, D.C.

WHO Meeting Report. 2006. Over View of Grey Water Management Health Considerations. Amman, Jordan

Wisconsin Department of Natural Resources, December 2013. Introduction to Ponds, Lagoons, and Natural systems study, Washington, D.C., <http://dnr.wi.gov/>

World Health Organization, Geneva, 1996. Guidelines for Drinking-Water Quality, 2nd ed. Vol.2

Appendix –A- Amount of Grey Water Produced

The Amount of Grey Water Produced and that Will be Unused per Person and per Household

The total amount of potable

$$\begin{aligned}\text{Water required per person} &= \text{Total daily usage of potable water X number of persons} \\ &= 110 \text{ l/c/d X1} \\ &= 110 \text{ l/c/d} \\ &= 0.110 \text{ m}^3/\text{c/day}\end{aligned}$$

The total amount of potable

$$\begin{aligned}\text{Water required per house hold} &= \text{Total daily usage of potable water X number of house holds} \\ &= 110 \text{ l/c/d *5} \\ &= 550 \text{ l/d} \\ &= 0.550 \text{ m}^3/\text{day}\end{aligned}$$

$$\begin{aligned}\text{Maximum daily demand of} &= \text{The total amount of potable water required per person x} \\ \text{potable water required per person} &\quad \text{maximum day demand factor} \\ &= 0.110 \text{ m}^3/\text{c/day x1.1} \\ &= 0.121 \text{ m}^3/\text{c/day}\end{aligned}$$

$$\begin{aligned}\text{Maximum daily demand of} &= \text{The total amount of potable water required per house hold x} \\ \text{potable water required per house hold} &\quad \text{maximum day demand factor} \\ &= 0.550 \text{ m}^3/\text{day x1.1} \\ &= 0.605 \text{ m}^3/\text{day}\end{aligned}$$

Whereas;

$$\begin{aligned}\text{Total volume of waste water} & \\ \text{produced per person} &= 80\% \text{ of the total maximum daily demand of potable water required} \\ &\quad \text{per person}\end{aligned}$$

Hence;

$$\begin{aligned}\text{Total waste water produced per person} &= 0.80 \times 0.110 \text{ m}^3/\text{c/day} \\ &= 0.088 \text{ m}^3/\text{c/day}\end{aligned}$$

The total volume of grey

$$\begin{aligned}\text{water produced per person (m}^3/\text{day)} &= \text{cloth washing usage +Bath and shower usage} \\ &= 21.7\% (0.019096 \text{ m}^3/\text{c/day}) + 18.6 \% (0.016368 \text{ m}^3/\text{c/day}) \\ &= 40.3\% \times 0.088 \text{ m}^3/\text{c/day or } 0.019096 + 0.016368 \text{ m}^3/\text{c/day} \\ &= 0.035464 \text{ m}^3/\text{c/day}\end{aligned}$$

The amount of grey water produced

$$\begin{aligned}\text{after treatment per person} &= 90 \% \text{ of the total volume of grey water produced per person (m}^3/\text{day)} \\ &= 0.90 \times 0.035464 \text{ m}^3/\text{c/day} \\ &= 0.0319176 \text{ m}^3/\text{c/day}\end{aligned}$$

The amount of grey water produced
that will be unused per person = 0.0319176 m³/ c/day
= 31.92 l/c/d

Whereas;

Total volume of waste water
produced per house hold = 80% of the total maximum daily demand of potable water required
per house hold

Hence;

Total waste water produced per house hold = 0.80x0.550 m³/day
= 0.44 m³/day

The total volume of grey water

Produced per house hold (m³/day) = cloth washing usage +Bath and shower usage
= 21.7% (0.09548 m³/day) + 18.6 % (0.08184 m³/day)
= 40.3% *0.44m³/day or 0.09548 +0.08184 m³/day
= 0.17732 m³/day

The amount of grey water produced

after treatment per house hold = 90 % of the total volume of grey water produced per house hold
(m³/day)
= 0.90 x 0.17732 m³/day
= 0.159588 m³/day

The amount of grey water produced that will be unused per house hold = 0.159588 m³/day
= 159.588 l/d

The Amount of Grey Water Produced in Jemo Gara Condominium Houses

The total amount of potable water

required in Jemo Gara condominium houses = 0.550 m³/day*2358
= 1296.9 m³/day

The maximum daily demand of potable water

required in Jemo Gara condominium houses = 0.605 m³/day*2358
= 1426.59 m³/day

Total waste water produced

in Jemo Gara condominium houses = 0.44 m³/day*2358
= 1037.5m³/day

The total volume of grey water produced

in Jemo Gara condominium houses = 0.17732 m³/day*2358
= 418 m³/day

The amount of grey water produced

after treatment in Jemo Gara condominium houses = 0.159588 m³/day*2358
= 376 m³/day

The amount of grey water produced that will be unused in Jemo Gara condominium houses = $0.159588 \text{ /day} * 2358$
= $376 \text{ m}^3/\text{day}$

The Amount of Grey Water Produced in Mickey Leland Condominium Houses

The total amount of potable water required in Mickey Leland condominium houses = $0.550 \text{ m}^3/\text{day} * 4638$
= $2550.9 \text{ m}^3/\text{day}$

The maximum daily demand of potable water required in Mickey Leland condominium houses = $0.605 \text{ m}^3/\text{day} * 4638$
= $2805.99 \text{ m}^3/\text{day}$

Total waste water produced in Mickey Leland condominium houses = $0.44 \text{ m}^3/\text{day} * 4638$
= $2041 \text{ m}^3/\text{day}$

The total volume of grey water produced in Mickey Leland condominium houses = $0.17732 \text{ m}^3/\text{day} * 4638$
= $822 \text{ m}^3/\text{day}$

The amount of grey water produced after treatment in Mickey Leland condominium houses = $0.159588 \text{ m}^3/\text{day} * 4638$
= $740.2 \text{ m}^3/\text{day}$

The amount of grey water produced that will be unused in Mickey Leland condominium houses = $0.159588 \text{ m}^3/\text{day} * 4638$
= $740.2 \text{ m}^3/\text{day}$

The amount of grey water produced from the existing condominium houses

The total amount of potable water required in 186,978 condominium houses = $0.550 \text{ m}^3/\text{day} * 186,978$
= $102,837.9 \text{ m}^3/\text{day}$

The maximum daily demand of potable water required in 186,978 condominium houses = $0.605 \text{ m}^3/\text{day} * 186,978$
= $113,121.69 \text{ m}^3/\text{day}$

Total waste water produced in 186,978 condominium houses = $0.44 \text{ m}^3/\text{day} * 186,978$
= $82,270 \text{ m}^3/\text{day}$

The total volume of grey water produced in 186,978 condominium houses = $0.17732 \text{ m}^3/\text{day} * 186,978$
= $33,155 \text{ m}^3/\text{day}$

The amount of grey water produced after treatment in 186,978 = $0.159588 \text{ m}^3/\text{day} * 186,978$
= $29,839 \text{ m}^3/\text{day}$

The amount of grey water produced that will be unused in 186,978 condominium houses $= 0.159588 \text{ m}^3/\text{day} * 186,978$
 $= 29,839 \text{ m}^3/\text{day}$

The amount of grey water produced from future condominium houses

The total amount of potable water required in **700,000** condominium houses $= 0.550 \text{ m}^3/\text{day} * 700,000$
 $= 385,000 \text{ m}^3/\text{day}$

The maximum daily demand of potable water required in **700,000** condominium houses $= 0.605 \text{ m}^3/\text{day} * 700,000$
 $= 423,500 \text{ m}^3/\text{day}$

Total waste water produced in **700,000** condominium houses $= 0.44 \text{ m}^3/\text{day} * 700,000$
 $= 308,000 \text{ m}^3/\text{day}$

The total volume of grey water produced in **700,000** condominium houses $= 0.17732 \text{ m}^3/\text{day} * 700,000$
 $= 124,124 \text{ m}^3/\text{day}$

The amount of grey water produced after treatment in **700,000** $= 0.159588 \text{ m}^3/\text{day} * 700,000$
 $= 111,711.6 \text{ m}^3/\text{day}$

The amount of grey water produced that will be unused in **700,000** condominium houses $= 0.159588 \text{ m}^3/\text{day} * 700,000$
 $= 111,711.6 \text{ m}^3/\text{day}$

Appendix –B- Laboratory Test Results

(a) Lab Test Results of Two-Barrel Plastic Grey Water Treatment Technology First Round

Dissolved oxygen (DO)

From Kality treatment plant laboratory report the amount of dissolved oxygen from the influent sample and Effluent sample the laboratory result shows that 1.95 and 3.13mg/l respectively.

PH

From Kality treatment plant laboratory report the PH value of influent and Effluent is 9.70 and 7.44 respectively.

Total solids (TS)

Calculating total solids concentration

$$\text{mg total solids /L} = \frac{(A - B) \times 1000}{\text{mL sample}} \quad (\text{TAHD, 1999}), \text{TAHD} = \text{Technical Assistance Hydrology Project}$$

Where:

A = weight of dish + residue, mg

B = weight of dish, mg

The laboratory result given as:

| | Influent | Effluent |
|---------------------------------|-------------|-----------|
| B. weight of dish, mg | = 63.408 mg | 64.127 mg |
| Volume of sample | = 20ml | 30ml |
| A. weight of dish + residue, mg | 63.475 mg | 64.150 mg |

Therefore,

$$\text{TS} = \frac{(A - B) \times 1000 \times 1000}{\text{mL sample}}$$
$$\text{TS Influent} = \frac{(63.475 - 63.408) \times 1000 \times 1000}{20}$$
$$= 3350 \text{mg/l}$$
$$\text{TS Effluent} = \frac{(64.150 - 64.127) \times 1000 \times 1000}{30}$$
$$= 767 \text{mg/l}$$

Total suspended solid (TSS)

Calculating total suspended solids (TSS) concentration:

$$\text{mg total solids /L} = \frac{(A - B) \times 1000}{\text{mL sample}} \quad (\text{TAHD, 1999})$$

Where:

A = weight of filter + dried residue, mg

B = weight of filter, mg

The laboratory result given as:

| | Effluent | Influent |
|---|------------|----------|
| B. weight of filter, mg | = 0.253 mg | 0.252 mg |
| Volume of sample | = 20ml | 20ml |
| A. weight of filter + dried residue, mg | = 0.255 mg | 0.2564 |

$$\begin{aligned} \text{TSS Influent} &= \frac{(0.2564 - 0.252) \text{ mg} \times 1000 \times 1000}{20 \text{ ml}} \\ &= 220 \text{ mg/l} \end{aligned}$$

$$\begin{aligned} \text{TSS Effluent} &= \frac{(0.255 - 0.253) \text{ mg} \times 1000 \times 1000}{20 \text{ ml}} \\ &= 100 \text{ mg/l} \end{aligned}$$

Total dissolved solids (TDS)

$$\text{TDS} = \text{TS} - \text{TSS} \quad (\text{TAHD, 1999})$$

$$\begin{aligned} \text{Therefore influent of TDS} &= (3350 - 220) \text{ mg/l} \\ &= 3130 \text{ mg/l} \end{aligned}$$

$$\begin{aligned} \text{Therefore out let of TDS} &= (767 - 100) \text{ mg/l} \\ &= 667 \text{ mg/l} \end{aligned}$$

Total volatile solid (TVS)

Calculating total volatile solid (TVS)

$$\text{Total Suspended Solids mg/L} = \frac{(B - A) \times 1000 \text{ mg/g}}{\text{Sample volume}} \quad (\text{Schumacher, 1989})$$

$$\text{Total Volatile Suspended Solids mg/L} = \frac{(B - C) \times 1000 \text{ mg/g}}{\text{Sample volume}}$$

$$\text{Total fixed Suspended Solids mg/L} = \frac{(C - A) \times 1000 \text{ mg/g}}{\text{Sample volume}}$$

Where;

A = weight of dish, mg

B = Weight of residues + dish, mg

C = weight ignition, mg.

| | | |
|------------------------------|-------------------------|-----------------------|
| Weight of ignition | Influent = 63.422 | Effluent 64.140 |
| Weight of dish, mg | = 63.408 mg | 63.408 |
| Weight of dish, mg | Influent = 63.408 mg | Effluent 64.127 mg |
| Volume of sample | = 20ml | 30ml |
| Weight of dish + residue, mg | = 63.475 mg | 64.150 mg |

For Influent

$$\text{Total Volatile Suspended Solids mg/L} = \frac{(B - C) \times 1000 \times 1000}{\text{Volume of sample}}$$

$$\text{Total Volatile Suspended Solids mg/L} = \frac{(63.475 - 63.422) \times 1000 \times 1000}{20}$$

$$= 2650 \text{ mg/l}$$

For Effluent

$$\text{Total Volatile Suspended Solids mg/L} = \frac{(B - C) \times 1000 \times 1000}{\text{Volume of sample}}$$

$$\text{Total Volatile Suspended Solids mg/L} = \frac{(64.150 - 64.140) \times 1000 \times 1000}{30}$$

$$= 333 \text{ mg/l}$$

Biological oxygen demand (BOD₅)

Calculating Biological oxygen demand (BOD₅)

For each test bottle meeting 2.0mg/l, 4.0mg/l and 6mg/l minimum DO depletion and 1.0 mg/l residual DO, BOD is calculated as follows:

$$\text{BOD}_5, \text{ mg/L} = \frac{(\text{DO}_i - \text{DO}_f)}{P} \quad (\text{Delzer, 2003})$$

When dilution water is seeded:

$$\text{BOD}_5, \text{ mg/L} = \frac{(\text{DO}_i - \text{DO}_f) - (\text{B}_i - \text{B}_f) f}{P}$$

Where;

DO_i = DO of diluted sample immediately after preparation, mg/L

DO_f = DO of diluted sample immediately after 5 days incubation at 20°C, mg/L

P = decimal volumetric fraction of sample used

$$\text{or } P = \frac{\text{Volume of sample}}{\text{Volume of bottle}}$$

B_i = DO of seed control before incubation, mg/L

B_f = DO of seed control after incubation, mg/L

f = ratio of seed in diluted after incubation, mg/L

From Kality treatment plant laboratory report the value of D_i and D_f for influent and Effluent is as:

Blank

DO_i = 7.03

DO_f = 6.88

| Volume of sample | Influent | | Effluent | |
|------------------|-----------------|-----------------|-----------------|-----------------|
| | DO _i | DO _f | DO _i | DO _f |
| 2ml | 7.20 | 3.88 | 7.37 | 6.52 |
| 4ml | 7.03 | 1.04 | 6.82 | 6.03 |
| 6ml | 6.76 | 0.53 | 6.85 | 5.82 |

For Influent

$$\text{BOD}_5, \text{ mg/L} = \frac{(7.20 - 3.88)}{2\text{ml}/300}$$

$$= 498 \text{ mg/l}$$

$$\text{BOD}_5, \text{ mg/L} = \frac{(7.03 - 1.04)}{4\text{ml}/300}$$

$$= 499.25 \text{ mg/l}$$

$$\text{BOD}_5, \text{ mg/L} = \frac{(6.76 - 0.53)}{6\text{ml}/300}$$

$$= 311.5 \text{ mg/l}$$

$$\text{Average} = \frac{498+449.25+311.5}{3}$$

$$\text{Average} = 419.58 \text{ mg/l}$$

For Effluent

$$\text{BOD}_5, \text{ mg/L} = \frac{(7.37 - 6.52)}{2\text{ml}/300}$$

$$= 127.3 \text{ mg/l}$$

$$\text{BOD}_5, \text{ mg/L} = \frac{(6.82 - 6.03)}{4\text{ml}/300}$$

$$= 59.25 \text{ mg/l}$$

$$\text{BOD}_5, \text{ mg/L} = \frac{(6.85 - 5.82)}{6\text{ml}/300}$$

$$= 51.5 \text{ mg/l}$$

$$\text{Average} = \frac{127.3+59.25+51.5}{3}$$

$$\text{Average} = 79.35 \text{ mg/l}$$

Chemical oxygen demand (COD)

Calculation

$$\text{COD as mg O}_2/\text{L} = \frac{(A - B) \times M \times 8000}{\text{mL sample}}$$

Where:

A = mL FAS used for blank

B = mL FAS used for sample

M = molarities of FAS, FAS= Standard ferrous ammonium sulfate titrant

8000 = milli-equivalent weight of oxygen X 1000 mL/L.

$$\text{Molarity (M) of FAS solution} = \frac{\text{Volume 1.5 ml K}_2\text{Cr}_2\text{O}_7 \text{ solution titrated, mL}}{\text{Volume FAS used in titration, mL}} \times 0.1$$

Taking 1.44 and 1.35 Volume FAS used in titration, mL for solution preparation

$$M1 = \frac{1.5}{1.44} \times 0.1$$

$$M1 = 0.1042$$

$$M1 = \frac{1.5}{1.35} \times 0.1$$

$$M1 = 0.1111$$

$$\text{Average M} = \frac{0.1042 + 0.1111}{2} \times 0.1 = \mathbf{0.1077}$$

Hence;

$$A = 1.11$$

$$B = 0.2$$

$$\text{Vol sample} = 1.5$$

$$M = 0.1077$$

Therefore

$$\text{COD as mg O}_2/\text{L} = \frac{(1.11 - 0.2) \times 0.1077 \times 8000}{1.5}$$

$$\text{COD as mg O}_2/\text{L} = \mathbf{522 \text{ mg/l}}$$

(b) Lab Test results of Two-Barrel Plastic Grey Water Treatment Technology Second Round

Dissolved oxygen (DO)

From Kaliti treatment plant laboratory report the amount of dissolved oxygen from the influent sample and the Effluent sample is 2.15 mg/l and 3.79 mg/l respectively.

PH

From Kaliti treatment plant laboratory report the PH value of influent and Effluent is 7.86 and 6.47 respectively.

Total solids (TS)

The laboratory result given as:

| | | |
|---------------------------------|-------------|-----------|
| | Influent | Effluent |
| B. weight of dish, mg | = 64.142 mg | 63.407 mg |
| Volume of sample | = 20ml | 20ml |
| A. weight of dish + residue, mg | = 64.165 mg | 63.420 mg |

Therefore,

$$\text{TS} = \frac{(A - B) \times 1000 \times 1000}{\text{mL sample}}$$

$$\begin{aligned} \text{TS Influent} &= \frac{(64.165 - 64.142) \times 1000 \times 1000}{20} \\ &= 1150 \text{mg/l} \end{aligned}$$

$$\begin{aligned} \text{TS Effluent} &= \frac{(63.420 - 63.407) \times 1000 \times 1000}{20} \\ &= 650 \text{mg/l} \end{aligned}$$

Total suspended solid (TSS)

The laboratory result given as:

| | Effluent | Influent (cannot filter) |
|-------------------------|------------|--------------------------|
| B. weight of filter, mg | = 0.254 mg | 0.253 |
| Volume of sample | = 20ml | 20ml |
| A. weight after drying | = 0.257 mg | 0.26 |

$$\text{mg total solids /L} = \frac{(A - B) \times 1000}{\text{mL sample}}$$

$$\begin{aligned} \text{TSS influent} &= \frac{(0.2596 - 0.253) \text{ mg} \times 1000 \times 1000}{20 \text{ ml}} \\ &= 330 \text{mg/l} \end{aligned}$$

$$\begin{aligned} \text{TSS effluent} &= \frac{(0.257 - 0.254) \text{ mg} \times 1000 \times 1000}{20 \text{ ml}} \\ &= 150 \end{aligned}$$

Total dissolved solids (TDS)

$$\text{TDS} = \text{TS} - \text{TSS}$$

Therefore the influent of TDS = (1150-330) mg/l
=820 mg/l

Therefore the effluent of TDS = (650-150) mg/l
=500 mg/l

Total volatile solid (TVS)

Calculating total volatile solid (TVS)

| | | |
|------------------------------|-------------|-----------|
| | Influent | Effluent |
| Weight of dish, mg | = 64.142 mg | 64.127 mg |
| Volume of sample | = 20ml | 20ml |
| Weight of dish + residue, mg | = 64.155 mg | 63.411 mg |

For Influent

$$\text{Total Volatile Suspended Solids mg/L} = \frac{(B - C) \times 1000 \times 1000}{\text{Volume of sample}}$$

$$\text{Total Volatile Suspended Solids mg/L} = \frac{(64.155 - 64.142) \times 1000 \times 1000}{20}$$

$$= 650 \text{ mg/l}$$

For Effluent

$$\text{Total Volatile Suspended Solids mg/L} = \frac{(B - C) \times 1000 \times 1000}{\text{Volume of sample}}$$

$$\text{Total Volatile Suspended Solids mg/L} = \frac{(63.411 - 63.407) \times 1000 \times 1000}{20}$$

$$= 200 \text{ mg/l}$$

Biological oxygen demand (BOD₅)

Calculating Biological oxygen demand (BOD₅)

From Kality treatment plant laboratory report the value of Di and Df for influent and Effluent is as:

Blank

DOi = 7.18

DOf = 6.35

| | Influent | | Effluent | |
|------------------|----------|------|----------|------|
| Volume of sample | DOi | DOf | DOi | DOf |
| 2ml | 6.66 | 5.34 | 7.14 | 5.75 |
| 4ml | 6.64 | 3.45 | 6.57 | 3.91 |
| 6ml | 6.77 | 3.47 | 6.58 | 4.67 |

For Influent

$$\begin{aligned} \text{BOD}_5, \text{ mg/L} &= \frac{(6.66 - 5.34)}{2\text{ml}/300} \\ &= 198 \text{ mg/l} \end{aligned}$$

$$\begin{aligned} \text{BOD}_5, \text{ mg/L} &= \frac{(6.64 - 3.45)}{4\text{ml}/300} \\ &= 239.25 \text{ mg/l} \end{aligned}$$

$$\begin{aligned} \text{BOD}_5, \text{ mg/L} &= \frac{(6.77-3.47)}{6\text{ml}/300} \\ &= 165.00 \text{ mg/l} \end{aligned}$$

$$\text{Average} = \frac{198+239.25+165}{3}$$

$$\text{Average} = 200.75 \text{ mg/l}$$

For Effluent

$$\begin{aligned} \text{BOD}_5, \text{ mg/L} &= \frac{(7.14 - 5.75)}{2\text{ml}/300} \\ &= 208.5 \text{ mg/ l} \end{aligned}$$

$$\begin{aligned} \text{BOD}_5, \text{ mg/L} &= \frac{(6.57- 3.91)}{4\text{ml}/300} \\ &= 199.5 \text{ mg/l} \end{aligned}$$

$$\begin{aligned} \text{BOD}_5, \text{ mg/L} &= \frac{(6.58- 4.67)}{6\text{ml}/300} \\ &= 95.5 \text{ mg/l} \end{aligned}$$

$$\text{Average} = \frac{208.5+199.5+95.5}{3}$$

$$\text{Average} = 167.83 \text{ mg/l}$$

Chemical oxygen demand (COD)

Taking 1.44 and 1.35 Volume FAS used in titration, mL for solution preparation

$$M1 = \frac{1.5}{1.44} \times 0.1$$

$$M1 = 0.1042$$

$$M1 = \frac{1.5}{1.35} \times 0.1$$

$$M1 = 0.1111$$

$$\text{Average M} = \frac{0.1042 + 0.1111}{2} \times 0.1 = 0.1077$$

Hence;

$$A = 1.0441$$

$$B = 0.198$$

$$M1 \text{ sample} = 1.5$$

$$M = 0.1077$$

Therefore

$$\text{COD as mg O}_2/\text{L} = \frac{(1.0441 - 0.198) \times 0.1077 \times 8000}{1.5}$$

$$\text{COD as mg O}_2/\text{L} = 486 \text{ mg/l}$$

Appendix –C- Questionnaire in Mickey Leland Condominium Residences

MY name is Asmamaw Mekonnen. I am a student of Addis Ababa university institute of technology department of civil engineering. As part of my MSc research project I am conducting the following survey. The purpose of this questionnaire is to assess the perception of Mickey Leland resident societies of water demand management measures, to know the community willing nesses and to follow such measures. Answering this questionnaire would help the utility to assess the perception of the residents about certain issues and the possible improvement of the services provided. All information gathered from this questionnaire will be used for academic purposes and it is free from any political issues. Furthermore, it will remain anonymous, treated confidentially and I will be destroying after the production of the final results. Thank you for taking time to answer the questionnaire.

Please read carefully the question and answer as honestly as you can on the right side of the paper by ticking the appropriate box.

1. Your address _____ Block number _____.
2. Your occupation _____.
3. Sex
A. Male B. Female
4. Age
A. 18-30 B. 31-40 C. 41-50 D. more than50
5. Number of your family members _____
6. Educational Level
A. Below elementary B. Middle-high school C. Diploma D. Bachelor degree or above
7. What is family middle monthly income
A. Less than 1500 B. 1501-3000 C. 3001-4000 D. More than 4000
8. Do you think that you live in an area where water shortage is a problem?
A. Yes B. Somewhat C. Never
9. Who is fetching water for performing house hold duties?
A. Females B. Males C. Both of them
10. Do you think you do your bit to save water?
A. Yes B. Not at all
11. What are the options that you get water during the absence of water?
A. Using the bite save water B. Buying Water from other places C. Both of them D. other
12. Do you think that your monthly water bill is costly?
A. Yes B. No
13. How much for water do you pay monthly?
A. Less than 16.17 birr B. from 20.77-75.95birr C. from 81.69-190.90 birr D. from 198.10-622.87 birr E. from631.88-2425.77 birr F. above 2425.77 birr
14. In which methods you are washing your clothes
A. Using washing machine B. using wide bucket C. Others
15. Where are you spill out the wastes from cloth washing?
A. For toilet B. for shower and bathes C. For road ditches D. Others
16. Do you own private car?
A. Yes B. No
17. Are you willing to use grey water; if a piloting treatment technology is installed in your home?
A. Yes B. No
18. Do you know grey water reusing saves money by reducing the cost expenses from billing? A. Yes B. No
19. How would you describe yourself regarding water use?
A. Wasteful B. Normal C. Conservative

Appendix –D- English Questionnaire Translation to Amharic Questionnaire

በመጀመሪያ ጊዜዎን ሰወተው መጠይቁን ለመሙላት ፈቃደኛ ስለሆኑ በጣም አመሰግናለሁኝ፡፡ ስሜ አስመዝግቦ መካካን እባላለሁኝ፡፡ በአዲስ አበባ ዩኒቨርሲቲ በሲቪል የምህንድስና ትምህርት ክፍል የሚከተሉት ተመራጭ ነኝ፡፡ ይህንን መጠይቅ ያዘጋጀሁት በሚሊ ላንድ የጋራ መኖሪያ ቤቶች የሚኖሩ ነዋሪዎችን የወላ አቅርቦትን መልሶ ከመጠቀም አኳያ ያላቸውን አመለካከት እና ግንዛቤ ምርምር ለማክሄድ እና ለማጥናት ነው፡፡ ይህንን መጠይቅ ሲገጥሙ ከማንኛውም የፖሊቲካ ጉዳዮች የፀዳ እና ለምርምር አገልግሎት ብቻ የሚወልደው መሆኑን በሚዳቅ መጠይቆችን ያለምንም ፍርሀት የራስዎን መልስ በትክክል በሚከበብ እንዲመልሱ በአኩብሮት እየጠየኩኝ የሚገባሉት መጠይቅም ከሪፖርት በኋላ የሚገኘው መሆኑን ለመገለጽ እወዳለሁኝ፡፡

1. አድራሻ _____ የብሉክ ቁጥር _____
2. የማኅዳደሩበት ስራ _____
3. ፆታ
ሀ. ወንድ ለ. ሴት
4. ዕድሜ
ሀ. 18-30 ለ. 31-40 ሐ. 41-50 መ. ከ 50 በላይ
5. የቤተሰብ ብዛት _____
6. የትምህርት ደረጃ
ሀ. ከ 6ኛ ክፍል በታች ለ. ከ6ኛ-12ኛ ክፍል ሐ. ዲፕሎማ መ. ዲግሪ እና ከዚያ በላይ
7. ወራዊ ገቢዎ ስንት ነው?
ሀ. ከ 1500 በታች ለ. ከ 1501-3000 ሐ. 3001-4000 መ. ከ 4000 በላይ
8. በሚኖሩበት አካባቢ የወላ ችግር አለ ወይ?
ሀ. አዎ ለ. አልፎ አልፎ ሐ. የለም
9. ለቤት ወስጥ አገልግሎት የሚሆን ወላ የሚቀደው ማን ነው?
ሀ. ሴቶች ለ. ወንዶች ሐ. ሁሉም
10. _____ ወላ በሚኖርበት ጊዜ ወላ የሚቆይ የወላ ማጣቀሻ አለዎት?
ሀ. አዎ ለ. የለም
11. _____ ወላ በሚኖርበት ወቅት ወላ ለማግኘት የሚጠቀሙት አሜራቶች ምን ምን ናቸው?
ሀ. ያጠረቀሙትን ወላ እጠቀማለሁኝ ለ. ወላ ካለበት አካባቢ ወላ በመገዛት እጠቀማለሁኝ ሐ. ሁለቱን ዘዴዎች እጠቀማለሁኝ መ. ሌላ ካለ ይግለጹ
12. _____ በወር የሚከፍሉት የወላ ክፍያ ወድ ነው ብለው ያምናሉ?
ሀ. አዎ ወድ ነው ለ. ርካሽ ነው
13. _____ በወር የሚከፍሉት የወላ ክፍያ ምን ያህል ነው?
ሀ. ከ16.17 ብር በታች ለ. ከ20.77-75.95 ብር ሐ. ከ81.69-190.90 ብር መ. ከ198.10-622.87 ብር ሠ. ከ631.88-2425.77 ረ. ከ2425.77 በላይ
14. _____ ልብስዎን የሚጥብባቸው ዘዴዎች ምን ምን ናቸው?
ሀ. የልብስ ማሽን በመጠቀም ለ. በሳፋ እና በሰፋፊ ባልዲ በመጠቀም ሐ. ሌሎች ካሉ ይግለጹ
15. _____ ልብስዎን ካጠቡ በኋላ ያጠብቡትን ወላ ወደ የት ያስወግዳሉ?
ሀ. ወደ ሽንት ቤት ለ. ወደ ሻወር ቤት ሐ. ወደ መንገድ ዲቻ /ዳር/ መ. ሌሎች ካሉ ይግለጹ
16. _____ የራስዎ የግል መኪና አለዎት?
ሀ. አለኝ ለ. የለኝም
17. _____ ገላዎን፣ እጅዎን እና ልብስዎን ከታጠቡ በኋላ የታጠቡትን ወላ በቤትዎ ወስጥ በአገልግሎት ቴክኖሎጂ ተጣብቆ ቢቀርብዎት ለሚፈልጉት አገልግሎት መጠቀም ይችላሉ?
ሀ. አዎ ለ. መጠቀም አልችልም
18. _____ ከገላዎ፣ ከእጅዎ እና ከልብስዎ የሚጠቀሙት ወላ መልሰው በመጠቀም የወላ ችግርዎንና ለወላ የሚጠቀሙትን ክፍያ እንደሚቀንስ ያውቃሉ?
ሀ. አወቃለሁ ለ. አላወቅም
19. _____ ከወላ አጠቃቀም አኳያ ራስዎን እንዴት ይገልጹታል?
ሀ. ወላን አባክናለሁኝ ለ. ወላን በአግባቡ እጠቀማለሁኝ ሐ. ወላን በቁጠብ እጠቀማለሁኝ

Appendix –E- Questionnaire for Interview

My name is Asmamaw Mekonnen Admasie. I am a student of Addis Ababa university institute of technology department of civil engineering. As part of my MSc research project I am conducting the following survey. The purpose of this questionnaire is to develop a demonstrator of water demand management in mass condominium housing development sites located in Addis Ababa City in view of grey water recycling based on appropriate grey water treatment technology. All information gathered from this questionnaire will be used for academic purposes. Furthermore, it will remain anonymous, treated confidentially and I will be destroying after the production of the final results. Thank you for taking time to answer the questionnaire.

Please read carefully the question and answer as honestly as you can on the right side of the paper by writing your answer in the space provided.

1. Do you think there is sufficient water supply for condominium houses? Why?
2. What are the advantages and disadvantages of grey water recycling?
3. Is there any advantage and disadvantages to achieve through separate plumbing of black water and grey water?
4. Do you think there will be a positive public opinion for the acceptance of grey water recycling
5. In which purpose do you think grey water recycling is applicable?
 - A. Toilet flushing
 - B. Floor cleaning
 - C. Gardening
 - D. Car washing
 - E. Cloth washing
 - F. For all
6. Is there any grey water treatment technologies that you know? Where?
7. Which one of the following consideration to be under taken for the selection of grey water technologies?
 - A. Quality of the grey water to be treated
 - B. Land space required for construction
 - C. Odor nuisance
 - D. Relative investment and running costs
 - E. Personnel skills required
 - F. Familiarity of the technology in the city

Appendix –F- Separate Design of Grey Water and Water Supply Riser Diagram