

**QUALITY ASSURANCE OF STRUCTURAL DESIGN CHECKING PROCESS IN
COMPUTERIZED ENVIRONMENT
(MODELING, DOCUMENTATION, PRESENTATION, VERIFICATION AND VALIDATION)**

by

Abel Bekele Assefa

**A Thesis submitted to the School of Graduate Studies
of Addis Ababa University
in partial fulfillment of the requirements for the degree of**

MASTER OF SCIENCE

in

**Civil Engineering
(Structural Stream)**

Advisor

Shifferaw Taye, Dr

March 14, 2012

Addis Ababa

Ethiopia

Copyright©2012, Abel Bekele Assefa

**ADDIS ABABA UNIVERSITY
SCHOOL OF GRADUATE STUDIES**

**ADDIS ABABA INSTITUTE OF TECHNOLOGY
DEPARTMENT OF CIVIL ENGINEERING**

**QUALITY ASSURANCE OF STRUCTURAL DESIGN CHECKING PROCESS IN
COMPUTERIZED ENVIRONMENT
(MODELING, DOCUMENTATION, PRESENTATION, VERIFICATION AND VALIDATION)**

by

Abel Bekele Assefa

APPROVED BY BOARD OF EXAMINERS

**Dr. Shifferaw Taye
Advisor**

Signature

Date

**Dr. –Ing Adil Zekaria
Internal Examiner**

Signature

Date

**Dr. –Ing Bedilu Habte
External Examiner**

Signature

Date

**W/t Meron Wondafrash
Chairman**

Signature

Date

DEDICATION

This work is dedicated to you, the reader. I greatly appreciate your interest and motive towards understanding and contributing your effort to improve the structural design checking process, so that quality structural designs are produced and implemented in town.

ACKNOWLEDGMENT

I am greatly indebted to my Advisor Shifferaw Taye (Dr) for his practice based guide during the various structural engineering courses in my stay at AAiT and also during this thesis. Without the addition of his decades experience in the structural engineering realm, this paper would be more of theoretical and impractical.

I am deeply touched by the consistent effort of Ephraim Senbetta (Dr) to send me invaluable information, despite his narrow schedule and many responsibilities, regarding the experience of United States of America in relation to my work.

My thanks go to Ato Bahiru Ahmed (Building Permit and Inspection Officer at Addis Ababa City Administration) for providing me with necessary data and sharing me his experience which constituted a lot in my work.

My sincere appreciation will also go to all professionals, authors and firms whose structural calculations, papers, books and various documents are referred and used during the study.

And what shall I more say? For the time and space would fail me to mention of all those I am indebted to.

CONTENTS

ACKNOWLEDGMENT.....	i
LIST OF FIGURES.....	iv
LIST OF TABLES	v
ABSTRACT	vi
1. INTRODUCTION.....	1
1.1 Background.....	1
1.2 Objective.....	1
1.3 Materials and Methods	2
1.4 Limitations	2
2. LITERATURE REVIEW	4
2.1 General	4
2.2 Quality Assurance and Structural Design	5
2.3 Legal Issues Concerning Structural Designs.....	9
2.4 Quality Assurance Methods.....	13
3. CASE STUDY AND FINDINGS	16
3.1 General	16
3.2 Documentation and Checking Practices in Addis Ababa	16
3.3 Checking Practice in United States of America	19
4. GUIDELINE FOR LOCAL APPLICATION.....	21
4.1 General	21
4.2 Structural Quality Assurance Checklist.....	21
5. COMPUTERIZED ENVIRONMENT IN STRUCTURAL ENGINEERING	40
5.1 General	40
5.2 Understanding the Limitations of Structural Engineering Software	41
5.3 Verification and Validation.....	44
5.3.1 General.....	44
5.3.2 Verification of Structural Design Results	45
5.3.3 Validating the Results of Structural Engineering Software	46

6. CONCLUSIONS AND RECOMMENDATIONS	52
REFERENCES	53

LIST OF FIGURES

Figure 1 Quality philosophy/Concept and control	6
Figure 2 Design project quality assurance model.	8
Figure 3 Some typical quality assurance methods	14
Figure 4 Quality assurance methods as discussed by Schwnger	14
Figure 5 Components in a typical QA program	15
Figure 6 Illustration of unrealistic computer-generated lateral load distribution to shear walls and moment frame.	42
Figure 7 Illustration showing influence of girder deflections on deflection at end of cantilevered beam.	44
Figure 8 Illustration of discrepancy between slab edge as modeled and actual slab edge location.	47
Figure 9 Illustration of a structural member (floor diaphragm) not designed by the software.	48

LIST OF TABLES

Table 1 Maximum Time Provided for Checking Structural Design (Source: Construction License Guideline 2/2001)	11
Table 2 Checklist for the Quality Assurance of Calculations, Design and Drawing Production.....	22

ABSTRACT

Researches based on past experience indicate that a considerable number of structural failures are mainly associated with human error in the design stage of structural engineering projects, and many of these problems could have been at least minimized if there had been adequate design checking. Contacts have been made with the chief engineers in Addis Ababa City Administration, Ministry of Urban Development and Construction, and design offices of selected sub cities. From them copies of structural calculation documents are collected. Results are reported herein from those data investigating and evaluating two major issues in the typical design-checking processes- (i) scientific/engineering content and (ii) consistency of the checking procedure. Following a review of current work in this area, appropriate checklist, which examines the effects different parameters, is prepared for a typical design checking process. Discussion on computerized environment in relation to structural engineering is carried out addressing points related to software limitations, verification and validation. Although a beginning work in this area, I believe the results will serve as a base for practicing professionals as well as for further study.

1. INTRODUCTION

1.1 Background

Albert Einstein once said "A clever person solves a problem. A wise person avoids it." In structural designs even if it is difficult to completely avoid we can greatly minimize problems/errors related to design.

This technologically booming era has imprinted its own impact on the construction industry. Clients, contractors as well as engineers want to complete their projects with fast schedules for their own different advantage. In relation to this the time allocated for structural design is drastically reduced. Codes are becoming complex, lengthy and too rapidly edited to follow even for the well known professionals. Graduate engineers are becoming increasingly dependent on illegal software programs to perform engineering analysis and design; this is worsened by the availability of tedious number of cracked structural software programs on the market. At country level, fresh engineers are widely involved in areas which require further education and appropriate experience. These and other scenarios added to our poor economy make quality assurance programs more important and inevitable for structural design checking process.

In recent years structural engineering consultants mushroomed across town. There are around 130 consultants currently only in the capital Addis Ababa (MWUD 2002), this doesn't include free-lance workers. Most of them use cheap cracked structural software programs and easily available fresh graduate civil engineers. To worsen the situation the city administration does not possess any quality assurance program or even it does not have the know-how about this issue. This fact shows how much it is mandatory for the checking authority either at firm level by the manager or at city level by the responsible city administration to have a comprehensive quality assurance program.

Not only from the checkers point of view but also from the engineer's perspective it is very interesting if he can assure the quality of his work in relation to the science, used software etc. before submitting the result for approval either for his boss or city administration.

1.2 Objective

The objective of this paper is to achieve three goals, basically in relation to reinforced concrete multistory buildings. These are:

- Evaluate how structural designs are checked by the responsible body in our country, taking Addis Ababa as a case study area.
- Comment how structural calculation documents need to be submitted in hard copy and how their contents can be investigated to assure the quality of the design at hand.

- Discuss the computerized environment in relation to structural software programs.

1.3 Materials and Methods

I wandered across town to visit offices related to structural design and checking which are to mention Ministry of Urban Development and Construction, Addis Ababa City Administration, and sub city centers,. In some of those areas I have observed structural designs being performed and checked by fresh and inexperienced graduates, and to the worst case by professionals with no relation to structural engineering or approved without any checking at all.

After reviewing literature concerning quality assurance in general and quality assurance in structural engineering in particular, a close examination was made on the facts and parameters related to it. Structural calculation documents of buildings constructed and being constructed in the city are collected and reviewed. The various contents in terms of scientific/engineering principles and report writing standards are commented on, appropriate conclusions and recommendations are forwarded, and standard quality assurance checklist is also prepared.

By closely scrutinizing software issues, some general points for appropriate verification and validation of computer outputs are discussed

1.4 Limitations

Even if the word structure can be defined as an organized combination of connected parts designed to carry loads and provide adequate rigidity (Euro code 0 'Basis of Structural Design', 2002) in this work when we mean structure the main focus is on multistory reinforced concrete buildings. The verb 'design' refers to defining the structural layout, defining the loads and load combinations acting on the structure, determining the forces and load effects on and in the structure and its elements, sizing the elements, and determining the details of the elements and connections. The noun 'design' refers to the process of designing, as well as the product of the process.

Implicit denial of most concerned bodies to give clear and honest information concerning their offices' checking process created difficulty to reach at a clear picture regarding the issue.

It is difficult to discuss all the quality assurance issues on this paper due to the complexity of the structural design discipline in relation to type and condition. For example the quality assurance issue for steel framed structure is not same as that of a reinforced concrete or composite structure. In addition quality assurance review for important and hazardous structures will not equal that for common buildings. In spite of this fact this paper will try to address the important areas which need consideration for quality assurance in relation to civil engineering structures in general and reinforced concrete buildings in particular. Also using this as a hint interested

professionals can develop detailed, brief and easily understandable quality assurance programs appropriate to specific structures.

2. LITERATURE REVIEW

2.1 General

The term "quality" is defined in different ways by many professionals and organizations.

According to Balci, 2003 the term "quality" gets its full definition when it is used with the words it is referred for. For example, product quality is the degree to which the product possesses a desired set of characteristics. The first product quality characteristic "product accuracy" is assessed by evaluating product verify and validity. Product verify is evaluated by conducting product verification and product validity is evaluated by conducting product validation. Process quality is the degree to which the process possesses a desired set of characteristics. The set of desired characteristics depends on the process methodologies and techniques employed. Project quality is the degree to which the project possesses a desired set of characteristics. Project quality is assessed by evaluation of a variety of characteristics including configuration management, documentation quality, human resource management, personnel capability maturity, planning quality, and quality management and so on.

International Organization for Standardization (ISO), which is the world's largest developer and publisher of International Standards, defines quality as "The totality of characteristics of an entity that bear on its ability to satisfy stated and implied needs" - ISO 8402 (ISO 2010).

For our case the ISO definition is easy to comprehend. Here the entity is "Structural design". To be said quality it must satisfy the intended needs these are related to engineering content, safety, function, economy, aesthetics and the like which are to be founded on engineering principles rather than commonsense.

Even if some people declare it is not the time to talk about quality in a poor country like ours Shifferaw Taye, 2008 argues the opposite. He emphasizes in poor economies like ours, where resource is terribly limited for maintenance and error rectification, quality is extremely desirable. According to him even after using the latest technology aids like CAD for fast and easy performance, quality assurance is mandatory. CAD is not going to create organizations where none exists, nor will it turn inferior designs into quality ones. What it will do, though, is automate the design and drafting processes and reduce the time you spend on repetitive, time-consuming tasks. It will give you more time to devote to the creative part of the civil engineering design and drafting if you avoid common mistakes during CAD selection.

When we come to "quality assurance" it was initially introduced in World War II when munitions were inspected and tested for defects after they were made. Today's quality assurance systems emphasize catching defects before they get into the final product (Anon n.d.).

According to Cai, 2008b the terms "quality control, QC" and "quality assurance, QA" are often used incorrectly. When we say quality control, it is a system of routine technical activities, to measure and control the quality of the product as it is being developed. While quality assurance activities include a planned system of review procedures conducted by personnel not directly involved in the compilation/development process.

OGCIO 2008 defines quality control as the process by which product quality is compared with applicable standards and actions taken when non-conformances are detected. Quality control is the responsibility of the worker. But quality assurance is a planned and systematic set of activities necessary to provide adequate confidence that requirements are properly established and products or services conform to specific requirements. It is sometimes called quality control over quality control because it evaluates whether quality control is working.

As can be understood from above the QC system is designed to provide routine and consistent checks to ensure data integrity, correctness, and completeness; identify and address errors and omissions; document and archive inventory material and record all QC activities. Whereas quality assurance is any systematic process of checking to see whether a product or service being developed is meeting specified requirements. It is a program for the systematic monitoring and evaluation of the various aspects of a project, service, or facility to ensure that standards of quality are being met. QA is more than just testing the quality aspects of a product, service or facility, it analyzes the quality to make sure it conforms to specific requirements and comply with established plans. Many companies have a separate department devoted to quality assurance. A quality assurance system is said to increase customer confidence and a company's credibility, improve work processes and efficiency, and enable a company to better compete with others. However it is important to realize that QA cannot absolutely guarantee the production of quality products but makes this more likely.

The quality manual of COOLTRON 2010 discusses quality philosophy and quality concept diagrammatically in a clear manner, which with slight modification is illustrated in Fig. 1.

2.2 Quality Assurance and Structural Design

Prior to 1990 the concept of formal QA programs was virtually unheard of within the profession worldwide. Quality was assured-as it is now being conducted in most local consulting firms-by relying on the experience, skill, continual oversight, and expertise of trained architects, engineers, and drafting personnel (C. Schwinger, n d).

The importance of quality assurance program in structural engineering design is unimpeachable due to various reasons. On a research entitled "Assessment of Delays in Ethiopian Public Building Construction Projects Executed by Local Contractors" (Abatemam & Dinku 2007) it is pointed out that among the top causes of delays identified by delay sub groups "Design related

delaysö has the 1st rank. Design related delays include necessary variations, changes in design, inadequate design team experience and incomplete documents. When the situation worsens the structural design problems goes beyond delay. As studied by Stewart, 1989 a large proportion of structural failures are due to human error in the design stage of structural engineering projects, and many of these failures could have been averted if there had been adequate design checking.

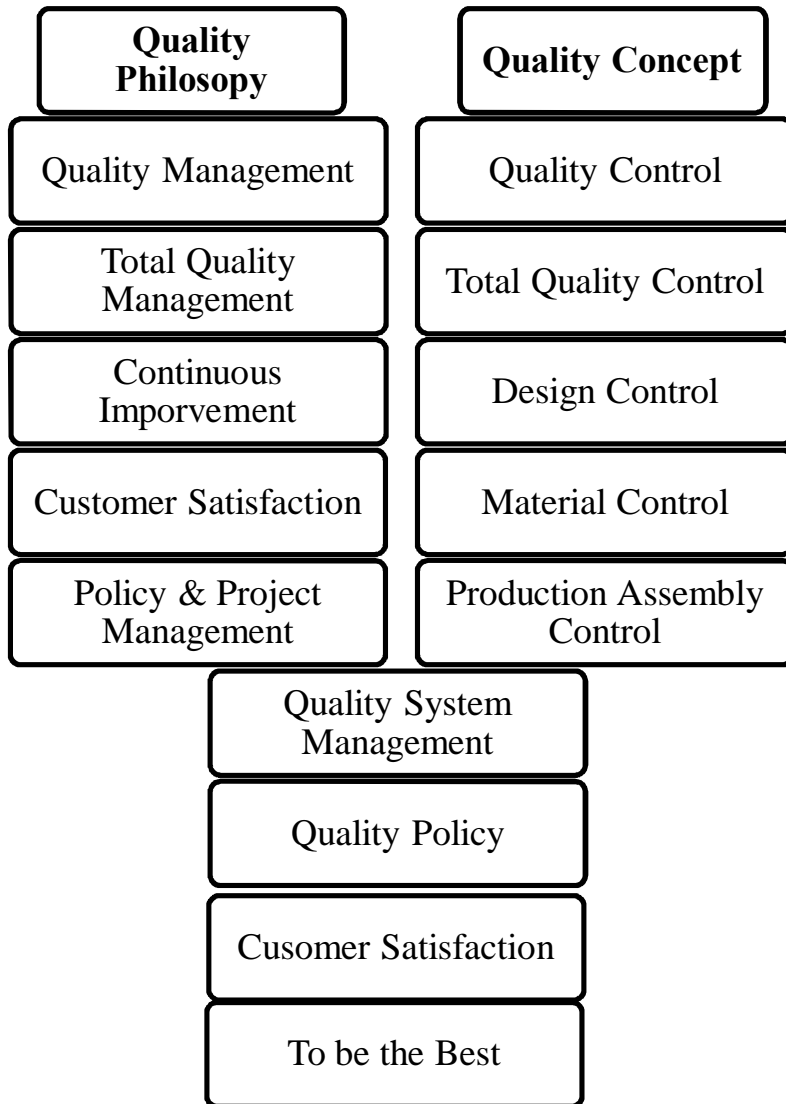

Figure 1 Quality philosophy/Concept and control

In addition to the above points, as discussed by Taye 2008, QA programs are very important to cope up with new challenges that continually occur in the field structural engineering. One challenge is that of recognizing the limitations and constraints of computer software and keeping

up with software changes and improvements, all the while keeping in mind that while computers are indispensable tools, they will never replace the judgment of experienced engineers who have mastered the art of structural engineering. Another challenge is that of training highly motivated young engineers so that they are best equipped to the skilled and productive professionals they enthusiastically strive to be. A comprehensive QA program can help them succeed and everyone benefits.

Our local code MoWUD, 1995 on Article 1.2.6 says quality assurance is important in order to provide a structure which corresponds to the requirements and to the assumptions made in the design. These measures comprise definition of the reliability requirements, organizational measures and controls at the stages of design, execution, use and maintenance.

C. Schwinger, 2010 believes there are no much relevant resources that talk about quality assurance in relation to structural engineering. He says this is a subject that unfortunately is given little attention within the profession. When we come to our country the topic is not much known among the structural community.

In relation to structural design quality assurance can be defined as a defined set of procedures and standards used to facilitate design and to facilitate documentation of that design. According to C. Schwinger, n d implementation of a QA program results in

- better design
- better drawings
- a more efficient design process
- fewer mistakes
- fewer request for information (RFIs) and change orders
- increased client satisfaction
- enhanced reputation
- increased financial returns

QA reviews are best performed by an engineer who was not involved in the project. A fresh set of eyes on a set of structural drawings will usually find more flaws than will someone who has intimate knowledge of the project (Schwinger & Meyer 2010).

According to Murphy & Wakefield n.d a core principle of most quality standards is to document. Document your requirements. Document your process. Document your results. Without documentation, it is impossible to trace what you did; it is impossible to show someone, such as a customer, that you met his needs; and it is impossible to repeat your results. Although documentation is often tedious, many tools help automate documentation activities by generating

standard reports. It is also impossible to overestimate the time savings good documentation will provide if you discover problems later or you want to reuse a design.

Schwinger n.d. emphasizes the importance for medium and large-sized engineering firms to have written formal design procedures, standards and methodologies in order to produce consistently high quality design and to minimize the risk of errors due to miscommunication. The purpose of office design standard is to keep everyone on the same page and to provide a roadmap to insure uniformity of design.

Shifferaw Taye, 2008 discusses the major shortcoming of a QC undertaking in local checking authorities. He says usually there is no uniform standard against which quality is controlled and that everyone is at the mercy of the experience of the individual working in the position, individual that can change position from time to time and/or from place to place living no trace of their documented achievements, if any at all. Besides this, it is this group of individuals that decide the fate of what "quality" may mean for any individual project without any reference to what that quality is referred to.

Fig. 2 illustrates a typical process for a quality assurance of a project accepted for construction.

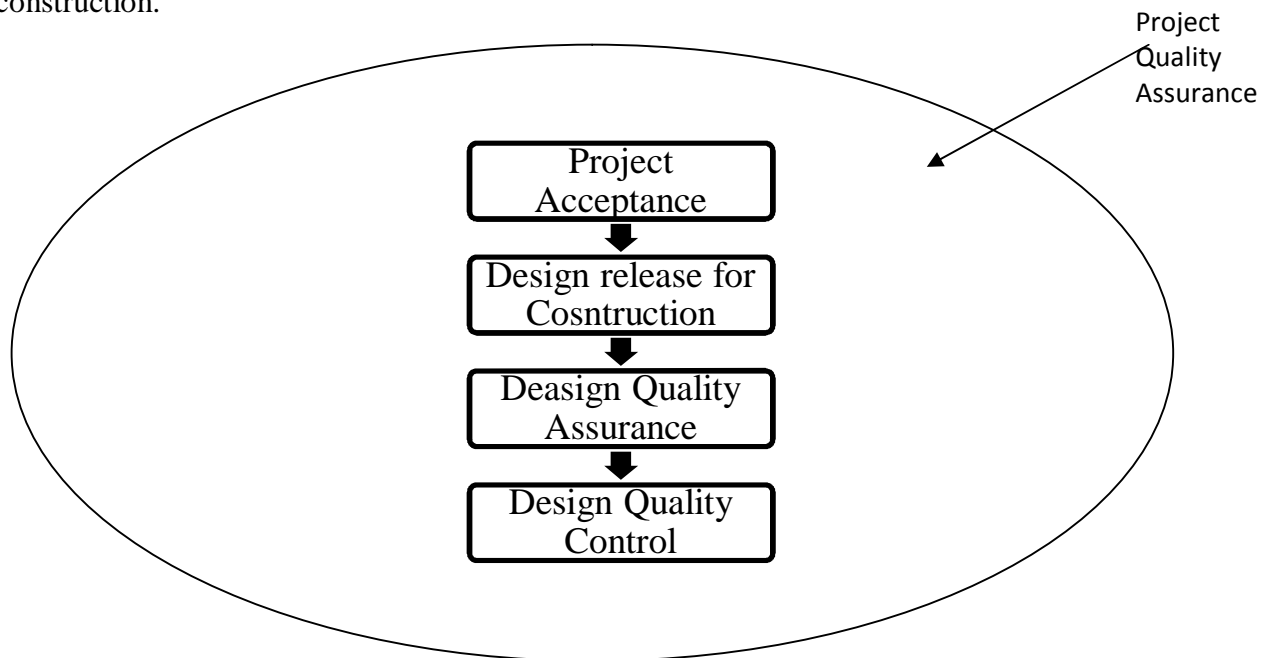

Figure 2 Design project quality assurance model

2.3 Legal Issues Concerning Structural Designs

To have quality structural designs and ethical structural community law has an important role. In this regard here we will review two locally available documents, viz. Construction License Permit Guideline 2/2001 (AAICA, 2001) & Ethiopia Building Proclamation No. 624/2009 (FDRE, 2009). Unfortunately few articles are given for this matter and even those discuss the issue in very general way. However since they are important as a starting point we will scan through them pointing out issues pertinent to our case.

Construction License Permit Guideline 2/2001

The guideline by Addis Ababa Infrastructure & Construction Authority called "Construction License Permit Guideline 2/2001", which is prepared for application to Addis Ababa region, discusses points in relation to construction. Especially chapter 3 gives emphasis to structural design.

Among different issues discussed by Construction License Permit Guideline 2/2001 the following are some to mention:

Wereda/Kebele, Sub City, and The City Administration have the responsibility to check designs for the typologies mentioned in article 1.3.1, 1.3.2, and 1.3.3 respectively.

We must have designs which do not risk the well being of the users and the society (Article 2.1.1).

Every design should satisfy the rules and regulations set by the guideline (Article 2.1.5).

Structural design is not needed for ground buildings whose roof is not slab and for fence construction (Article 2.3.1.1).

Except for the case of Article 2.3.1.1 documentation of buildings should include structural design and structural calculations (Article 2.3.1.2).

For structures supporting notice boards, structural design should be provided (Article 2.3.1.7).

Monuments, statues and similar structures need structural design (Article 2.3.1.8).

Buildings to be constructed adjacent to existing buildings need structural design which include the adjacency effect with engineering solution (Article 2.3.3, Article 2.5.1.11A).

If a design doesn't qualify the standards the reason why it is forbidden will be written in a form and submitted to the owner (Article 2.4.2).

If claim is raised against the decision in Article 2.4.2 appeal can be made to the appropriate body following the legal steps (Article 2.4.3).

If the design documentation is not presented in appealing and clear manner and if this is assured by the professional checker the design can be rejected (Article 2.4.5).

Structural design has to be submitted for retaining wall construction to prevent damage to existing adjacent buildings (Article 2.5.5).

For large projects the checker has authority to ask softcopy of the documentation if required (Article 3.1.3).

The checker has authority to select between international standards for the purpose of selecting by which standard the document has to be submitted (Article 3.1.8).

Statical calculations should include design initials and assumptions, standard code used for design, statical calculation of all structural components, the software used to prepare the design (Article 3.2.2.2).

For components that need structural design, documentation for the structural design can be asked (Article 3.2.2.4).

It is obligatory for every construction design to be carried out by the appropriate legal and licensed organization/person (Article 6.1.2 of 1/97 not 2/2001).

If appropriate and necessary temporary structures can require structural design (Article 2.6.3.1).

The other important point discussed by the Construction License Permit Guideline 2/2001 is the specific time allocated for performing different design checks (Article 2.3). As can be seen from the table under article 2.8.1 (duplicated here in Table 1 with slight modification), the maximum time allocated including electrical and sanitary checking is 10 hours for mixed purpose buildings. Therefore it will be the structural engineer's duty to perform the checking wisely within the allocated time and simultaneously catching out errors that hinder the quality of the design.

As can be seen from Table 1 there will be important duty expected both from the designer and the checker that means

- The designer must prepare and present his design documentation (structural calculations and drawings) in such a way that it is brief, precise, clear, professional, standard and readable.
- The checker must beforehand know which part to check, and which critical area to give his focus, and also how to perform the checking process with the above short time effectively and correctly in acceptable way.

Even though the points mentioned on the Guideline are important and are to be addressed, they are very general. This means additional guidelines which aid the implementation of each point raised in the guideline are needed.

Table 1 Maximum Time Provided for Checking Structural Design (Source: Construction License Guideline 2/2001)

No	Structure Type	Maximum Time Needed for Checking Structural Design (hours)
1	Residential building (≤ 2 floors)	1
2	Residential building (≥ 3 floors)	4
3	Mixed purpose building (≤ 3 floors)	6
4	Mixed purpose building (4-5 floors)	8
5	Mixed purpose building (≥ 6 floors)	10
6	Industry ($\leq 500 \text{ m}^2$ area)	5
7	Industry (500-1000 m^2 area)	8
8	Industry ($\geq 1000 \text{ m}^2$ area)	10
9	Notice	1
10	Maintenance	1
11	Demolition	2
12	Existing structure modification	6
13	Temporary structures	1

Ethiopian Building Proclamation No. 624/2009

The Ethiopian Building Proclamation No. 624/2009 is a proclamation by the federal government which as a purpose has to determine the minimum national standard for the construction or modification of buildings or alteration of their use in order to ensure public health and safety (FDRE 2009).

Here are some points of importance discussed by the latest Proclamation:

A person intending to erect a building shall employ a qualified registered professional for each type of design required for the category of the building and retains their services for the purpose of supervising the erection thereof. The details shall be determined by Regulation to be issued for the implementation of this Proclamation. The technical work of the building design shall be coordinated by the architect (Article 26).

Any registered professional who has contracted to carry out the design work of buildings shall produce guarantee for any damage resulting from any defective work due to the design (Article 26).

Any building shall have designs required for the category it belongs (Article 30).

Any building or components thereof shall be designed according to acceptable building design codes to ensure safety, comfort and unconstrained services (Article 30).

Any building shall be designed and constructed in such a way that it ensures safety for people, the construction and properties (Article 30).

Any building shall be designed and constructed in such a way that it shall not impair the safety of people moving around, other constructions and properties (Article 31)

The load from any newly constructed foundation shall not affect existing foundations, utility lines or any other structure (Article 31).

Any building and any structural element or component thereof shall be designed to provide strength, stability, serviceability and durability in accordance with accepted principles of structural design. Such buildings may not exhibit signs of structural failure during their span under normal loading (Article 34).

Any building shall be designed and constructed in such a way that it shall not impair the integrity of any other building or property (Article 34).

Any registered contractor or sub contractor who is issued with a work permit by the relevant authority: performs a construction work which causes damage as a result of his failure to rectify the errors on the design or other contract documents which were easily detectable by a professional of his kind; is punishable with rigorous

imprisonment from five years up to ten years and a fine from fifty thousand to hundred thousand birr (Article 53).

Any owner of a building who causes the drawing up of the design or the construction work of such construction by a person who is neither qualified nor authorized to perform such works; is punishable with imprisonment from five years to ten years and a fine from birr twenty thousand to fifty thousand (Article 53).

Any registered professional who is involved in a construction work as a design or construction consultant: prepares the design or other relevant documents of a construction without having due regard to the general safety regulations set forth for such specific work; or advises or permits a contractor or a supplier to procure or use a cheaper or, unwarranted quality or different material which is not acceptable by normal standards for the specific work, or relieves him of using a specific material essential thereto; or approves a construction work capable of endangering public safety or the life, health or person of other or the safety of the property of another; is punishable with rigorous imprisonment from five to fifteen years or a fine from birr thirty thousand up to fifty thousand (Article 54).

Our Building Proclamation discusses important issues which help in the development of quality work. However, additional supplementary regulations in relation to structural engineering need to be issued for the proper implementation of the Proclamation. Among those is the Structural Quality Assurance Checklist which we are going to develop in this paper.

2.4 Quality Assurance Methods

There are two primary goals of QA reviews. The first and most important goal is to review the contract documents to verify that the structure was properly designed, is efficiently framed and facilities provided, and is constructible. The second goal is to verify that the contract documents are complete, well detailed, correct, and coordinated (Taye 2008).

Some of the techniques used during Quality check process are summarized in Fig. 3 (Outsourcing Structural Design, n.d).

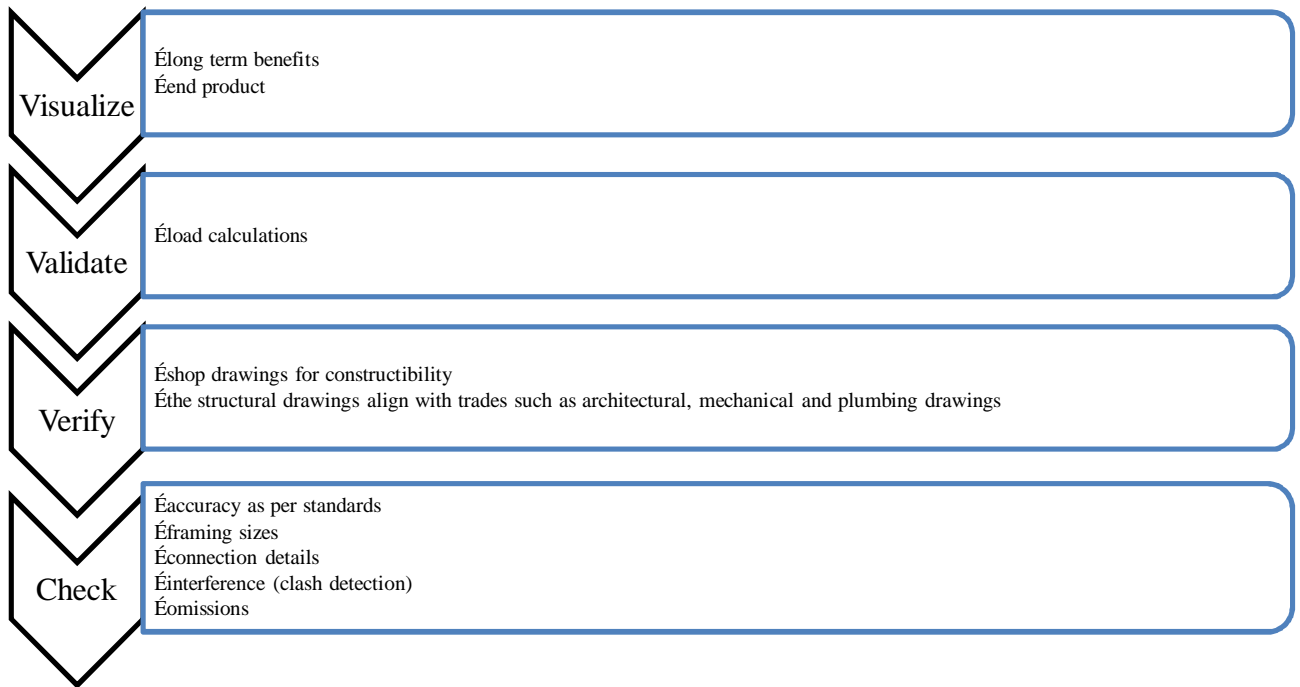

Figure 3 Some typical quality assurance methods

Schwinger, n d discusses similar techniques as shown in Fig. 4.

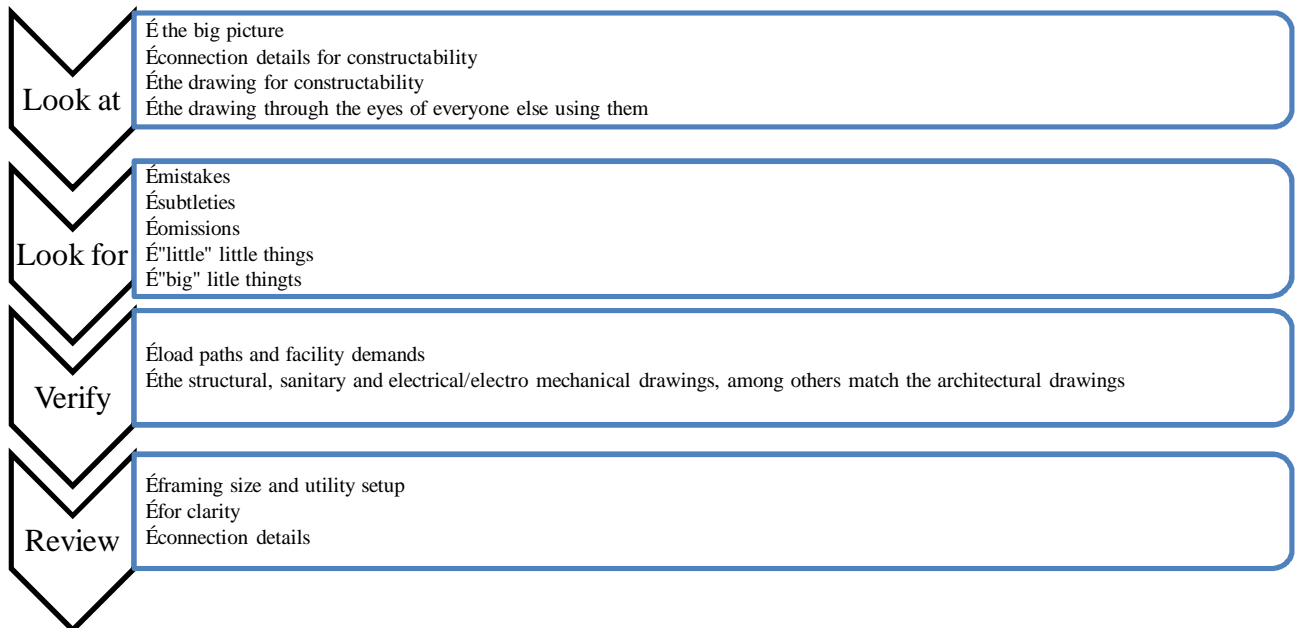

Figure 4 Quality assurance methods as discussed by Schwnger.

According to Schwinger, n d a QA program should include important components which are vital for the achievement of a quality end. These are illustrated in Fig. 5.

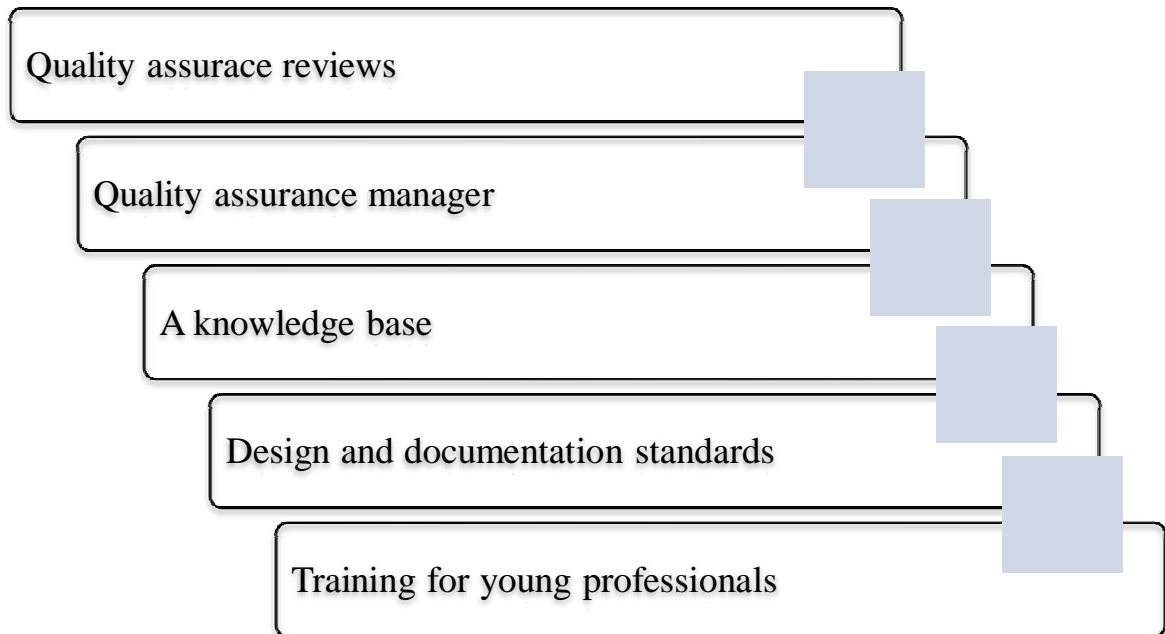

Figure 5 Components in a typical QA program

3. CASE STUDY AND FINDINGS

3.1 General

Addis Ababa is divided into 10 sub cities and 116 weredas (AACA 2010). Different constructions have been done and are being done in those different weredas.

For the case study in Addis Ababa the following offices are selected

- Ministry of Urban Development and Construction
- Addis Ababa City Administration
- Selected sub city building license offices

Those are visited to have the following information

- How do they receive design data i.e. documentation (hardware, software, etc)
- How do they evaluate the contents of the document? What is to be included and not to be included in the design document i.e. Presentation.
- How do they check accuracy of the output for those performed using computer programs
- How do they verify and validate results in the structural calculation documents.

As a research instrument I used personal interview with responsible professionals in the area, reviewing structural calculation documents of buildings constructed or under construction in Addis Ababa and my personal observation.

3.2 Documentation and Checking Practices in Addis Ababa

I have collected around 15 structural calculation documentations from various places (Addis Ababa City Administration - 6, Ministry of Works and Urban development - 2, consulting offices - 7).

Analysis of their contents based on the following criteria is carried out

- Scientific/Engineering content
- Consistence of the checking process

Scientific/Engineering content

Generally from the reviewed structural calculation documents we can easily observe that they are composed of some or all of the following parts

- ⌚ Literature containing explanations
- ⌚ Calculations illustrating analysis and design of building elements
- ⌚ Excel spreadsheet outputs for analysis and design
- ⌚ Structural software analysis and design outputs
- ⌚ Drawings

Rather than a report most documents are a collection of detached concept containing word pages, a junk of structural software outputs printed in arbitrary manner, and Excel spreadsheets printed as page increment; put under a cover page and bind together. The pages in the documents seem to have a mere purpose of increasing document size and mischief the checking authority in charge. Some repeatedly observed and important mistakes in most documents in relation to the above parts are presented below.

Literature containing explanations

- ⌚ They do not follow formal report writing procedures at ALL!! (lack coherence, no contents/poorly organized content/content that does not go up with the body, unorganized arrangement, poor sentence and grammar, unrefered tables and drawings, no references, no source cited, no pagination etc).
- ⌚ They lack similarity of truth. What is mentioned in the introduction as a code, ðused softwareö, constant, or experiment result will not be at all used or is forgotten/neglected in the body. This to some extent indicates the document is a mere collection of pages from various past documents or computer saved files in a manner to seem a real work and serve as a fulfillment for the approval required.
- ⌚ Some seem to have missing pages, others has repetitive pages either literally or in quality.
- ⌚ Incompatible content outline and body part.
- ⌚ Most of the documents use same or similar introduction parts (even in terms of words, phrases and constants); that is they lack taste of originality and trigger a sense of blind copying of others work.

Calculations illustrating analysis and design of building elements

- ⌚ Using different codes for same concept
- ⌚ The initial assumptions and what is really carried out in analysis and design are different
- ⌚ Wrong engineering concepts are used

- ⌚ On the introduction many codes are mentioned to be used, but it is not clear which code is used for which part
- ⌚ Not writing down the main assumptions and loadings
- ⌚ Not demonstrating that the validity of the computer output has been checked
- ⌚ Not showing hand calculations made to supplement computer calculations
- ⌚ Not showing how the design calculations fit together in a whole
- ⌚ Inconsistent or incorrect use of load combinations in design
- ⌚ Lateral design of structure has not been addressed or is incomplete
- ⌚ Calculations do not address all primary structural plans
- ⌚ Vertical and lateral load paths are not clearly defined on the structural drawings.

Excel spreadsheet programs for analysis and design

Spreadsheets can be a very powerful tool. Their use is becoming increasingly common in the preparation of design calculations. They can save time, money and effort. They provide the facility to optimize designs and they can help instill experiences. However, these benefits have to be weighed against the risks associated with any endeavor. These risks must be recognized and managed. In other words appropriate levels of supervision and checking, including self-checking, must as always, be exercised when using these spreadsheets.

Many of the spreadsheets I have observed tend to be error propagators, their origin is not at all known. Once a spreadsheet is prepared it is used by many offices without much questioning of its accuracy. This makes the spreadsheets famous and used by many without their errors being corrected.

- ⌚ On the Excel spreadsheets used the assumption at the beginning regarding the design philosophy and what is really used in the body is different.
- ⌚ There is no trend of revising the contents in the spreadsheet, so slight errors remain unresolved in all offices where that spreadsheet is used.
- ⌚ Some spreadsheets are difficult to comprehend easily and to spot where errors have occurred.
- ⌚ Some documents consist of more than one bundle. I obtained a huge documentation, a separate book, for the slab analysis and design only. Generally speaking this document is a collection of Excel spreadsheets prepared for slab analysis and design for each slab designation (i.e. means all were printed and documented) - with the floor plan drawings attached at the end.

Structural software analysis and design outputs

- ⌚ Hardly visible drawings and tables
- ⌚ Unlabelled tables and drawings
- ⌚ Horizontal members contour outputs printed in black (it is impossible to visualize stress variation which is indicated by different color changes in the software).
- ⌚ Bulky software output that has to be attached as an Appendix or Annex is incorporated in the body and distract reading the document
- ⌚ It is not clear about which building part the tables and figures are refereeing
- ⌚ In modeling all the structural members were considered including the stair structures
- ⌚ Using cracked software programs
- ⌚ Some tables especially those from software output and spreadsheets are hardly visible and the bulk addition of those pages seems simply to increase the document's size
- ⌚ A bulk amount of software output is printed, which makes the report cumbersome.

Drawings

- ⌚ Hardly visible drawings
- ⌚ Unlabelled drawings,
- ⌚ It is not clear about which building part the drawings are refereeing

Consistence of the checking process

Currently there is no uniform guideline used in the checking process at Addis Ababa City Administration; even if it is promised to be prepared, till now it has not been effected. This makes the engineer to fully relay on his own experience to check the designs. As it is obvious, this fact leaves the quality of the checking process at the mercy and experience of the engineer in position. And when the engineer leaves position without leaving any or little trace of his experience, the new comer will experiment his own ways for his new job.

The above facts make the checking process very inconsistent, which extremely damages the quality of structural designs.

3.3 Checking Practice in United States of America

In USA review and approval of structural designs are done relaying on the experience of the person doing the review and there are no specific methodologies, tools or checklists that are used (Senbetta, 2011). Here is a direct quote from a professor of structural engineering at Cornell University (who is not volunteer his name to be mentioned): "I do not think there is any particular protocol anywhere. Each design firm does it a different way, and each building inspector's office does it a different way, both varying from comprehensive to trivial. I tell my design students to NOT develop the expectation that their work will be routinely checked by

more senior professionals. It is often not checked, especially if the final output looks about like what the more senior supervisor would have expected."

By and large, the responsibility for the design rests with the design professional. Quality is inferred through the registration process and the engineer's seal on the design drawings. If design issues arise, he (and not the building official) is held solely responsible."

Building permits are issued by local Building Officials in cities, towns and villages. Depending on the municipality, the submission requirements for a building permit vary. At a minimum, sealed drawings are required. Some require sealed drawings and specifications, while others require sealed drawings and calculations. Typically, the calculations reside with the design engineer and the degree of review depends on the internal procedures of his firm. For the most part, most US firms require a review by another engineer in the firm and most use conventional and pretty much proven software (RISA, SAP, ABAQUS, NASTRAN, etc.). Engineering judgment is typically used to verify the computer results. In rare cases, independent analyses are performed.

Regarding the guidelines city administrations use to check structural designs in different states of America, it vary from one municipality to another. For example, the City Of Chicago has a checklist of required items (applicable codes, design loads, lap splice tables, etc.) that they use and if any standard items are missing or irregular, the permit gets bounced. More and more, municipalities are outsourcing design reviews for building permits. But, again, the quality of the review depends primarily on the engineering judgment of the reviewer.

As can be seen from the above information, the situation in US is better due to the fact that there are sufficient numbers of well trained engineers with experience who can do the work. And also the license given for the engineers and firms is very studied and given after a careful and deep scrutinization. In this regard the quality of license for professionals and firms in our country is debatable and it will need a deep study.

The doing in US implies that it is difficult for the officer in charge at City Administration to do a step by step and detailed check of all documents piled on his desk. Therefore it has to be given due emphasis to assure the quality and ethics of professionals and firms in the field.

4. GUIDELINE FOR LOCAL APPLICATION

4.1 General

In our case "documentation" refers to the complete set of design drawings, calculations, documents and electronic files used or produced by the structural designer in the process of designing a structure.

Any design should be done and documented in such a way that it will be possible for an experienced structural designer who has full access to the design documentation used or produced by the designer, to easily extract sufficient information to assess the adequacy of any member in the structure, without the assistance of the original structural designer.

A poor documentation makes it very difficult for anybody within or outside the design office to do any check of the work. And when questions arise or something goes wrong, it tends to be almost impossible to determine how it can be related back to the design calculations.

These guidelines are intended to spell out what is good practice with respect to the documentation of a typical structural design. It incorporates perspectives in relation to material, loading, modeling and the like. It is recommended that the guidelines be adopted as a minimum standard by design offices, clients or authorities.

4.2 Structural Quality Assurance Checklist

Below on Table 2 is given a checklist which can be used as a guide line for local applications in the quality assurance process. It is tried to make the checklist complete and to cover important points in the scope of our country and in relation to a typical building structural design. However by no way it is guaranteed that the checklist is full, complete, and absolute or it will produce quality designs. It is the full and sole responsibility of the engineer/firm/authority to make additions, omissions or corrections to what is mentioned based on the nature of the specific project at hand, so that he will achieve his intended purpose.

Table 2 Checklist for the Quality Assurance of Calculations, Design and Drawing Production

XYZ BUILDING DEPARTMENT QUALITY REVIEW CHECKLIST (Address)					
Date: _____					
Title: _____					
Project No: _____					
Location: _____					
Organization: _____					
Reviewed by: _____					
#	Item to be Checked	Yes	No	Yes with Condition	Not Applicable
1.	Number of deliverable copies				
2.	Document size appropriate				
3.	Cover page 3.1 Topic 3.2 Project name 3.3 Building picture 3.4 Engineer's name 3.5 Submitted to 3.6 Purpose of project 3.7 Location 3.8 Title deed number 3.9 Firms logo (if exists) 3.10 Firms full name and address 3.11 Date				
4.	License number				
5.	Calculation index				
6.	Building code used 6.1 Ethiopian building code of standards 6.2 Euro code 6.3 American concrete institute 6.4 Unified building code 6.5 International building code 6.6 Other (Specify) _____ 6.7 Other (Specify) _____				

Table 2 Checklist for the Quality Assurance of Calculations, Design and Drawing Production (cont.)

#	Item to be Checked	Yes	No	Yes with Condition	Not Applicable
7.	Selected structural system 7.1 Steel 7.2 Concrete 7.3 Timber 7.4 Composite of steel and Concrete 7.5 Other (Specify) _____ 7.6 Other (Specify) _____				
8.	Geometry 8.1 Bay Size 8.2 Story Height 8.3 Appropriate roof framing System 8.4 Floor framing system 8.5 Lateral force resisting system 8.6 Structural dimensions match architectural drawings 8.7 Member Orientation 8.8 Load path for gravity load 8.9 Load path for lateral load 8.10 Mechanical load support				
9.	Software program/s 9.1 Version specified 9.2 Catalogue attached 9.3 License from software owner 9.4 Limitations and assumptions discussed				
10.	Symbols used consistent				
11.	Unites used consistent				
12.	Design working life correct				
13.	Occupancy category correct				
14.	Roof category correct				
15.	Materials of construction specified				

Table 2 Checklist for the Quality Assurance of Calculations, Design and Drawing Production (cont.)

#	Item to be Checked	Yes	No	Yes with Condition	Not Applicable
16.	<p>Loading</p> <p>16.1 Roof load</p> <p>16.2 Floor load</p> <p>16.3 Wind load</p> <p>16.4 Seismic load</p> <p>16.5 Flood load</p> <p>16.6 Machine load</p> <p>16.7 Abnormal load</p> <p>16.8 Dynamic load</p> <p>16.9 Thermal load</p> <p>16.10 Any special load applicable to the specific building considered</p>				
17.	Correct design values are used				
18.	Serviceability limits met				
19.	Modeling concept appropriate				
20.	Consistent and correct load combination				
21.	Load cases appropriate				
22.	Analysis method appropriate				
23.	Design philosophy appropriate				
24.	<p>Drawings:</p> <p>24.1 Footing</p> <p>24.2 Foundation column</p> <p>24.3 Pile cap</p> <p>24.4 Column</p> <p>24.5 Beam</p> <p>24.6 Slab</p> <p>24.7 Floor expansion joints</p> <p>24.8 Wall</p> <p>24.9 Wall expansion joints</p> <p>24.10 Stair case</p> <p>24.11 Roof</p> <p>24.12 Roof expansion joints</p> <p>24.13 Floor and roof openings</p>				

Table 2 Checklist for the Quality Assurance of Calculations, Design and Drawing Production (cont.)

#	Item to be Checked	Yes	No	Yes with Condition	Not Applicable
24.	Drawings (cont.) 24.14 Connections 24.15 High stress elements 24.16 Fabrication drawings 24.17 Enough section drawings shown 24.18 Appropriate detail drawings 24.19 Clear and well presented drawing notes 24.20 All drawings coordinate with architectural and mechanical requirements				
25.	Concrete 25.1 Concrete cover 25.2 Tie spacing and arrangement 25.3 Development length 25.4 Reinforcement continuity for negative moment areas 25.5 Minimum compression member reinforcing 25.6 Minimum foundation pedestal reinforcing 25.7 Minimum footing thickness above bottom reinforcing on soil. 25.8 Minimum footing thickness above bottom reinforcing on piles 25.9 Retaining wall reinforcing shown in the correct locations				

Table 2 Checklist for the Quality Assurance of Calculations, Design and Drawing Production (cont.)

#	Item to be Checked	Yes	No	Yes with Condition	Not Applicable
26.	Masonry				
	26.1 Masonry dimensions appropriate				
	26.2 Control joint locations and spacing for masonry construction				
	26.3 Bond beams shown correctly				
	26.4 Masonry wall anchorage				
	26.5 Allowable number of stories above ground met				
	26.6 Seismic requirements				
27.	Steel				
	27.1 Adequate stiffeners provided				
	27.2 Complicated/unusual connections detailed				
	27.3 Reactions/loads provided for connections not detailed				
	27.4 Base plates- minimum bolt number satisfied				
	27.5 Base plate elevations for all columns				
	27.6 Bracing gusset plates do not interfere with anchor bolts				
	27.7 Minimum fillet weld size shown				
	27.8 Special loading conditions for steel bar joists shown				
	27.9 Bar joist connections at column				
	27.10 Bar joist seat depth correct				
	27.11 Bar joist bridging shown				

Table 2 Checklist for the Quality Assurance of Calculations, Design and Drawing Production (cont.)

#	Item to be Checked	Yes	No	Yes with Condition	Not Applicable
27.	<p>Steel (cont.)</p> <p>27.12 Bar joist bridging connections to wall or frame</p> <p>27.13 Weld pattern for steel decks shown</p> <p>27.14 Side lap and end lap fastening</p> <p>27.15 Steel decking continuous over three spans</p> <p>27.16 Special connection types fully detailed</p> <p>27.17 Bracing connections fully developed</p> <p>27.18 Truss connections fully developed</p> <p>27.19 Camber information is full</p> <p>27.20 Member erect ability is fully feasible</p>				
28.	<p>Timber</p> <p>28.1 Notches and holes</p> <p>28.2 Truss bottom chords braced for compression due to load reversals</p> <p>28.3 Truss profiles provided for prefab trusses</p> <p>28.4 Truss loading requirement shown</p> <p>28.5 Permanent bracing of prefab trusses shown</p> <p>28.6 Cross grain bending and tension avoided</p> <p>28.7 Nailing schedules provided</p> <p>28.8 Diaphragm and shear wall nailing shown</p>				

Table 2 Checklist for the Quality Assurance of Calculations, Design and Drawing Production (cont.)

#	Item to be Checked	Yes	No	Yes with Condition	Not Applicable
28.	Timber (cont.) 28.9 Top plate splice detail shown 28.10 Roof diaphragm shear transfer to shear walls shown				
29.	Foundation 29.1 Foundation design consistent with geotechnical report 29.2 Minimum footing depth 29.3 Minimum footing width 29.4 Footing step elevations close 29.5 Foundation wall step elevations close 29.6 Hold down locations clearly shown 29.7 Pile cups minimum thickness 29.8 Seismic requirements for pile foundations				
30.	Calculations 30.1 Live load reduction 30.2 Deflections (short & long term) 30.3 Drift 30.4 Concrete and masonry wall anchorage 30.5 Partition live load included 30.6 Folding partition accounted for 30.7 Roof dead load corrected for slope 30.8 Wind uplift addressed				

Table 2 Checklist for the Quality Assurance of Calculations, Design and Drawing Production (cont.)

#	Item to be Checked	Yes	No	Yes with Condition	Not Applicable
30.	Calculations (cont.)				
	30.9 Retaining wall (no requirement for sliding and overturning)				
	30.10 Ponding on flat roofs				
	30.11 Flexural strength reductions				
	30.12 Moment magnification considered for concrete columns				
	30.13 Crack control for reinforced concrete structures				
	30.14 Rolling forces considered for purlins				
	30.15 Second order effects considered for steel frames				
	30.16 Load duration factors applied correctly for timber design				
	30.17 Allowable stress adjustment factors applied correctly				
31	Effect on adjacent structures considered				
32	Construction/Maintenance friendly				
33.	Local regulations met				
	33.1 Construction License Permit Guideline 2/2001				
	33.2 Ethiopian Building Proclamation No. 624/2009				
34.	Geotechnical data is attached				
35.	References are attached				
36.	Appendix/annex attached				
37.	Signing and stamping				

Table 2 Checklist for the Quality Assurance of Calculations, Design and Drawing Production (cont.)

#	Item to be Checked	Yes	No	Yes with Condition	Not Applicable
38.	Electronic documents				
	38.1 Drawings				
	38.2 Software outputs				
	38.3 Different calculations				
	38.4 Other (specify) _____				
	38.5 Other (specify) _____				
THE STRUCTURAL DESIGN IS:					
Accepted		Rejected		Accepted with condition*	
This is to certify that I have examined the within detailed statement, together with a copy of the plans relating thereto, and find the same to be in accordance with the provisions of the law relating to building in the City, that the same has been approved and entered into the records of this department.					
_____		_____		_____	
Structural Engineer		Signature		Date	

It is difficult to make a hard and fast rule based on weighted values on the checklist, which defines how to handle the cases "Approved", "Rejected" and "Approved with condition". It is the judgment of the structural engineer in charge to make sensible decisions after deep scrutiny. The points in the checklist are mere guiding points, which can never substitute engineering observations made by the engineer.

Some points on and in relation to Table 2 which need explanation are briefly discussed below.

Number of deliverable copies

One copy of the document is enough for approval purpose. After a go on permission is obtained or the necessary comments and corrections are carried out all required number of copies can be requested. This makes the work more economical on the firm side and easy to handle on the checkers perspective.

Document size

The more you write probably the more you confuse your readers. Hence limiting document size is very important. All calculations and everything you did in your office is not mean it has to be attached in your documentation. The purpose of the documentation is neither illustrating a step by step example for students nor proofing your proficiency in the profession. It is a mere illustration of materials and data you have used and how you have used them with a clear explanation of assumptions and methodologies employed. These data must be enough to such an extent that other professionals can repeat your analysis and design with the indicated givens and reach at similar conclusion as your own without the assistance of your knowledge. To achieve this purpose very small number of sheets is adequate (let us say 50 page structural calculation documentation for 20 story mixed use reinforced concrete building!!). This may surprise you but I guarantee you this is more than enough.

Cover page

A cover page, containing the following information, must be provided for the document:

- ⌚ The topic: "Structural Analysis and Design Calculations" or "Structural Calculations" not "Statistical Calculations". The type of analysis (static, dynamic, linear, non-linear etc) will be mentioned in the body with engineering justification.
- ⌚ for: Project name: short name based on the projects function like "Structural Analysis and Design Calculations for Hospital Project", "Structural Analysis and Design Calculations for Mixed Use Building Project" etc. Detail explanation about geometry and location (like G + 4 etc) has to be given inside the document not in the cover page.
- ⌚ By: Designers name followed by firms name
- ⌚ Date
- ⌚ Submitted to: "XYZ City Administration Building License and Permit Office".
- ⌚ For í . Purpose. For Review Purpose or For Final Construction: depending on whether the report is submitted to be checked by the building permit office or final for construction respectively
- ⌚ Firms logo (if exists)
- ⌚ Firms full name and address

Calculation index

A full list of contents should be provided that will enable an outsider to easily locate the calculations of any structure or structural member. Correct pagination will aid this process.

Project description

At the beginning clear information about the project has to be provided. Need of this new project, story number, location, salient features of the project, estimated cost, built up area, undertaker of the project, social and economical benefit, impact on environment and all other information required for a full understanding of the project should be provided.

Design license

If the design is submitted by a freelancer, he has to show his original ID on person (no need of copy). For consulting firms since the responsibility is of the firm not the individual employed in the firm no need of attaching a specific person's license copy.

Building code used

The first step of the design procedure for a structure is to determine which design codes apply and the appropriate code date in effect. At the very beginning of the design, the structural engineer shall confirm the appropriate code, code reference standards, and the code edition.

In addition to the general design codes/standards, the specific material codes/standards shall also be followed in the structural design of various construction materials. These specific material codes/standards form the technical basis of the structural engineering design. (Examples for Aluminum, for concrete etc).

In addition to the basic design codes, thorough knowledge and the correct interpretation of specific material codes/standards are the essentials for a structural engineer to be competent and successful. And these interpretations have to be indicated clearly in the appropriate place.

Here an important emphasis is to realize that our local code "Ethiopian Building Code Standard" as its name suggest is a building code. Therefore appropriate international codes have to be used for structures other than building.

Similar to structural software programs, limitation and assumption of codes also has to be observed. Our local code for example limits conditions of structures to which it is applicable on different chapters.

Software program/s used

Brief explanation of the software used including name, producing organization, version, license obtained from the software developer/legal agent, which feature is used for the particular project etc. has to be mentioned. Many of the information can be found from the producer's website.

Important emphasis here is on the license obtained from the software developer/legal agent, because cracked illegal software programs cannot be used for real world structures.

In the name of documentation, one may end up printing thousands of pages from software output. It is important that a civil-engineering software system be customizable as to the content, document format and page layout of its output. It must further support an integrated text and graphics output. Instead of printing all or tedious number of pages from software analysis and design, it will be economically and easily checkable if important files and representative samples are printed and the remaining software file submitted by softcopy in non-editable format.

Symbols used

All symbols used in the calculations should be consistent with the symbols used in the particular structural code of practice or standard being used. If two or more codes with different symbol are used, the symbol in the code which is mostly referred has to be used.

Units used

All units used in the calculation should be consistent with the units used in the particular structural code of practice or standard being used. And they should be consistent throughout the report. If two or more codes with different unit system are used, the unit in the code which is mostly referred in the report has to be followed.

Materials

Materials (concrete, steel, masonry, wood, etc), grade of materials and stresses of materials used in design (bending, shear, compression) should be noted in the calculations.

Construction materials have to be consistent with building type identified in the code. Materials also must conform to structural standards.

Loading

The determination of loads to be applied on a structure is a critical step in the design procedure. Although most general design codes have specified load types to be applied to a structure, the quantitative determination of exact loads to be used for a structure is dependent on the structural engineer.

Since the complexity of codes in the development of wind and seismic loads on a structure can lead to engineering mistake, careful attention and due emphasis has to be given.

Consistent and correct use of load combinations

A Load Combination is a named combination of the results from Load Cases or other Load Combinations. Combo results include all displacements and forces at the joints and internal forces or stresses in the elements.

Modeling

A model is a representation or abstraction of something such as an entity, a system or an idea. The modeling of a real world structure may be a routine duty or may be a challenging task, depending on the level of complexity of the structure being considered. The basic requirement is that the structural members shall be modeled accordingly as beam/columns, truss members, or tension-only members.

The most frequently encountered problems are the modeling of the connections and supports of a "real world" structure. Because the type of connections and supports may drastically affect the stress and deformation of a structure and its individual members, the engineering principles and scientific reasoning, as well as construction feasibility, shall be considered in the modeling procedure. In most situations, the connections and supports are not pure theoretical pinned or fixed connections. Certain types of spring connections or supports should be used to better predict the real performance of the structure and its members.

If software programs are used the modeling technique used by the software has to be implied, such as center line modeling.

The lateral load resistant mechanism has also to be implied. Is the frame system fully responsible or are there additional lateral load resisting mechanisms such as shear walls have to be clearly stated.

It is to be noticed that prudent engineering judgment plays a key role in the modeling of a "real world" structure.

Load Cases

A Load Case defines how the loads are to be applied to the structure (e.g., statically or dynamically), how the structure responds (e.g., linearly or nonlinearly), and how the analysis is to be performed (e.g., modally or by direct-integration.)

Analysis method

Analysis can be linear or nonlinear. Linear analysis can be: static analysis, modal analysis for vibration modes, using eigenvectors or Ritz vectors, response-spectrum analysis for seismic response, time-history dynamic response analysis, buckling-mode analysis, moving-load analysis for bridge vehicle live loads, steady-state analysis, and power-spectral-density analysis. Nonlinear analyses can be: nonlinear static analysis, nonlinear time-history analysis.

Calculations

Comprehensive calculations, understandable to outsiders and clearly showing the conclusions reached, must be made. Calculations, including computer analysis and design results, should be presented on neat, standardized sheets containing the project details, the person and company responsible for the design, and the date.

Where structural analysis and/or design is done by computer, the calculations are intended to underpin the work performed by computer, showing how the input was derived, that the correctness of the computer work was tested, and that supplementary calculations were made where the software was not adequate. A sketch of the computer model must be included.

Each structural member should be assigned a component number, corresponding with the component number shown on a drawing or sketch included with the calculations. Wherever appropriate, drawings or sketches should also be made of each element assembly or connection, with the loads, load effects, forces and/or stresses acting on or in it, to assist understanding.

Calculation should note the final member size as shown on the plans, including the support conditions.

Calculations should contain the following information:

- ⌚ Proper identification of the structure, assembly, element and/or connection the calculations refer to
- ⌚ Clear definition of all loads, load combinations and other effects considered in the design, with clear distinction made between unfactored and factored loads and effects
- ⌚ Assumptions made with respect to the fixity of joints and continuity of members in modeling the structure
- ⌚ Analysis results, e.g. bending moment, axial load or shear force diagrams, or values
- ⌚ Clear demonstration that each member in the structure is adequately sized to ensure that all relevant load effects (e.g. bending, shear, axial load, web crippling, web bearing, deflection, etc.) can be resisted safely

- ⌚ Design calculations for a representative number of elements to demonstrate that the elements designed by computer were designed correctly, using the most adverse combination of load effects acting on an element or group of elements
- ⌚ Full calculations for all elements and/or connections for which the software used is not adequate, demonstrating compliance with the relevant code of practice

Connection design calculations

All member forces which are required for the design of end connections between steel components should be defined including:

- ⌚ The maximum design (factored) beam end shear (and axial load and moment, where applicable) indicated at each beam end.
- ⌚ All the combinations of design (factored) axial forces that must be considered in the design of connections between axially loaded members.
- ⌚ A column schedule defining the maximum design (factored) axial load (and bending moments where applicable) in each segment of a column.
- ⌚ Location of slip-resistant connections.
- ⌚ Connection design based on load path vs reported member end force: e.g. For a concentric braced frame with an in-plane offset, the connection of beam to column may need to be designed for the reported end force plus the horizontal component of the brace.

Drawings

Drawings include:

- ⌚ Drawings defining all structural elements, including plans, elevations, sections, and details, with adequate cross-referencing.
- ⌚ Define all connections by either defining specific connection details or referencing to industry standard connection details or specifying forces for a propriety connection system.
- ⌚ Construction sequences and positions or control/construction joints.
- ⌚ Include stairs/ plant platforms and facade system support.
- ⌚ Reinforcing details defined.
- ⌚ Precamber/set established for members.
- ⌚ Include seismic and gravity support of ceiling/partition systems (optional).

The final design drawings form an integral part of the design documentation. The design drawings must bear the name of the organization concerned and must be numbered, dated and signed by the registered person concerned.

For steel structures and if appropriate for the specific project, the set of design drawings should include the design of complex (moment-transmitting) connections, as well as the forces and effects to be taken into account in the design of connections by a structural detailer.

Where additional drawings or sketches have been produced in the design process, these must be included in the calculations.

Specifications

These include

- ⌚ Detailed specifications for each structural trade.
- ⌚ Performance specifications where appropriate, including performance criteria for proprietary design.
- ⌚ Method statements for critical construction processes governing design.
- ⌚ Design loadings for design of proprietary non-structural elements e.g., glazing, seismic bracing of services.
- ⌚ Define deliverables from contractor e.g., producer statements, shop drawings, and testing requirements
- ⌚ Coating requirements for structural elements that are not addressed by the architect or other disciplines.
- ⌚ Define required tolerances where different from industry standards.

Compatibility with other design outputs

It is frequently observed that, especially when the schedule for the project is tight, the architectural or mechanical plans refer to some details in the structural plans; unfortunately, the structural plans may not include such referred details if the structural engineer has not been informed by the architect or mechanical engineer. These kinds of communication problems usually arise when there is lack of efficient coordination within the project team. These things have to be scrutinized carefully before the design is approved.

Electronic documents

Electronic documents include drawings, software data files and other files which are too bulky to be printed. All computer input and output files should be included with the design documentation in soft copy. All data files and the location of all information should be clearly given in the design documentation, together with all instructions and information required for someone other

than the designer to access the information. The designer should provide access to software if he is requested to do so.

Here the important emphasis is electronic documents should be submitted in non-editable format, this protects the copyright of the producing firm and it also prevents error propagation across town using editable files whose origin is unknown. It also protects the firm from legal consequence if it might happen the softcopy is modified illegally in the checking office.

References

All codes of practice, books, publications, drawings, etc used in the design should be cited at the place where they are used or referred. And at the end all cited materials have to be listed in the appropriate reference writing format. One can use citation and referencing software programs like Mendeley or Zotero to handle large number of sources easily.

Appendix/annex

An annex is essentially part of the main text but is placed at the end separately so as to make the whole document clearer; whereas an appendix contains information not essential to understanding of the paper, but may present information that further clarifies a point without burdening the body. In a way one could say an annex can also be called an appendix but the same is not true for appendix. In general, for policy matters, the appendices are usually assumed to have been written by the original author of the document. The annexes, on the other hand, are usually assumed to have been written by an external party.

Important reports like geotechnical and the like should be attached in brief manner as annex.

Signing and stamping

Completed drawings and calculations that are submitted for building department plan review but are not final should be stamped, signed, dated and clearly identified: "For Permit Review Only, Not For Construction."

Completed drawings and calculations that have satisfied the permit review process and have had corrections made, should be stamped, signed, dated and clearly identified: "Final Construction Documents."

The quality assurance form from the firm should be signed, stamped and dated with the name of the quality assurance review manager in the firm.

Computer generated signatures and dates are not permitted. All final documents must bear original "wet" signature, stamp and date.

Archival history

Design calculations and design drawings must be retained for a minimum of ten years after the date of completion of the structure.

5. COMPUTERIZED ENVIRONMENT IN STRUCTURAL ENGINEERING

5.1 General

Software developers regularly receive demands for improvements to structural engineering analysis and design software which will not require the user to have extensive knowledge of theoretical details. For example, users of such software demand that the software developer create an environment where the user need not read the user manual. Since high quality structural engineering software includes user reference manuals consisting of numerous volumes of documentation describing the details of what the software does, what its limitations are, and the theory and assumptions upon which its calculations are based, the structural engineer is reluctant to use such software. The fact is that many structural engineers today do not want to be bothered with such details. What they want and are willing to pay for is a windows interface that permits them to cause information processing to occur, and to cause results to be displayed in full color graphics format, with animation if possible, and with pretty formatted printed display of numerical information. Concerns for whether or not duplicate eigenvalues can be detected correctly, or whether or not a sufficient number of modes are being used to obtain correct response spectrum analysis results, or whether or not the theory used to represent the behavior of nonlinear cable elements is correct, or whether or not analysis results are sensitive to the geometry of a finite element mesh or the type of element formulation incorporated into the software, or whether or not the theory for analyzing partial end moment fixity is correct, etc., etc., etc., are rarely, if ever, expressed by engineers using computers today.

Of course, computer technology itself is not inherently bad. Rather, the way in which computers are being used for structural engineering computation, and the continuing trend of growing misuse, is the problem. There is a huge ethical obligation on the part of senior engineers and engineering managers to emphasize the importance of knowledge, expertise, and experience in engineering practice. In the practice of structural engineering, it is critical to know the *why* of design, rather than only being concerned about knowing the *how* of using computers. Professional structural engineers must emphasize principles, fundamentals, modeling techniques for hand solutions, how to recognize errors in computation, alternative ways of creating solutions to structural engineering problems, validating computer produced results, respect and fear of computers, skepticism of computer produced results, respect for experience in engineering practice, the need to learn engineering by doing engineering (not by doing *finite element analyses of the world*, or by oversimplifying the world to fit within the limitations of incompetent structural engineering software), and the importance of learning structural engineering from other senior and experienced real structural engineers (i.e., the rapidly diminishing number of real engineers who still remember how to engineer without the need for computers). It is only by training professional engineers, not by training engineering technicians (i.e., computer operators), that the profession of structural engineering will fully meet its responsibilities and obligations to the public it serves.

5.2 Understanding the Limitations of Structural Engineering Software

The use of engineering software is an important tool for efficiently analyzing and designing building structures; however, in order for engineers to effectively use computer software, they must understand the limitations of their software and know how to quickly validate the results with manual calculations.

Mid to large firms should designate in house experts for each program used. These individuals are responsible for understanding of updates, training the rest of the office and answering questions.

Understanding software assumptions and limitations is crucial to avoiding problems. While computers are good at bulk analysis and design, they only are capable of accomplishing the specific tasks for which they were programmed. Knowing the limit states not considered by the software is crucial to ensuring safe and complete structural design.

Software issues typically fall into one of four categories:

- Incorrect or misunderstood default settings
- Conditions not considered by the software
- Constructability issues
- Programming errors and idiosyncrasies

Incorrect or misunderstood default settings

Misunderstanding software defaults can lead to mistakes varying from minor to catastrophic. A single set of default settings should be used office-wide, and these defaults should not be modified without consent of the engineer in charge. When software is upgraded to a newer version, default settings must be reviewed to ensure that they have been copied properly from the previous version, and that no new defaults have been added.

Conditions not considered by the software

Conditions not considered by the software include limit states or load path issues that the program does not check. Software users manuals do not dwell on software shortcomings, and lists of things not analyzed or designed are usually not provided.

Some typical examples of items not checked by most analysis and design software are:

- Column bracing requirements: Do members bracing columns have sufficient strength and stiffness?

Slab on metal deck capacity: Does the slab on metal deck have sufficient strength to span between beams?

Floor diaphragm strength and stiffness: Do floor diaphragms have sufficient strength and stiffness to transfer loads to the lateral load resisting system, and are connections between diaphragms and the lateral load resisting elements sufficient? Is the distribution of lateral loads to the lateral load resisting system resulting from a rigid diaphragm assumption a realistic one? Figure 6 illustrates how a computer analysis distributed lateral loads to the shear walls and moment frames in a precast concrete parking structure. A rigid diaphragm default setting was used in the computer analysis. While the structure did have substantial torsional stiffness, engineering judgment dictated that the computer analysis resulted in too little load going into the moment frame. The design practically requires the moment frame to carry substantially more lateral load than the computer analysis required.

Drag struts: Are drag struts required to transfer loads from floor diaphragms to lateral load resisting elements?

Wind girt design: Were wind girts designed to resist lateral wind loads?

Connection designs: Are connections designable without requiring expensive details such as web reinforcing plates, stiffeners, etc.?

Connections workpoints: Are connection workpoints assumed by the software the same as the workpoints assumed by the engineer and indicated in the details on the Contract Documents?

Concrete column load transfer through floor slabs: Where column concrete strength is higher than the floor slab compressive strength, will the slabs have sufficient strength to transfer the column loads through the floors?

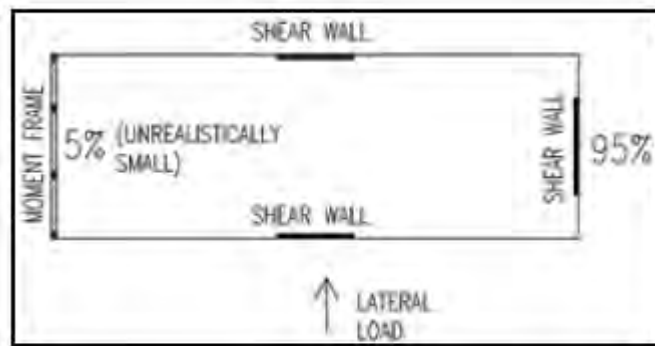

Figure 6 Illustration of unrealistic computer-generated lateral load distribution to shear walls and moment frame.

Constructibility issues

All engineers should review their designs for constructability. Computer software will generally not consider constructability issues unless those issues are addressed indirectly in the default settings.

Some typical constructability issues include:

Reinforcing steel in concrete columns: For economy and ease of construction, try to limit the percentage of steel in columns to 2 percent.

Top reinforcing steel in concrete slabs perpendicular to slab edges: Select bars such that hooked bars at slab edges can be easily installed in thin slabs. Hooks on larger bars will hinder installation of thin slabs.

Use of commonly available reinforcing steel

Review constructability of connections for steel and cast-in-place concrete construction: Constructibility of connections is a whole topic in and of itself. Suffice to say, computers are capable of designing any imaginable configuration of framing; however, a review must be performed to understand whether connections can be accomplished in an efficient and economical manner.

Standardization of reinforcing steel configurations: The optimal least-weight reinforcing steel arrangement generated by a computer analysis may not always be the least-cost configuration.

Programming errors and idiosyncrasies

Computer programs occasionally have flaws. Engineers need to be familiar with these flaws and understand how to work around them. Finding software flaws can be challenging, and when they are discovered, all engineers using the software must be alerted to them.

An example of a flaw of this type is one in which a program incorrectly computes deflections at the ends of cantilevered beams when the cantilevers are supported by transverse girders. Some programs do not consider effects of the girder deflections when computing the deflection at the tip of the cantilever and, accordingly, can substantially underestimate the cantilever deflection (Figure 7).

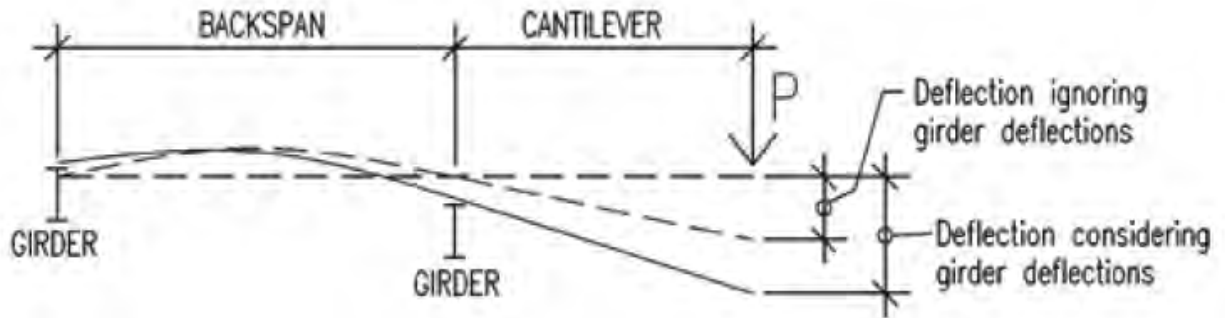

Figure 7 Illustration showing influence of girder deflections on deflection at end of cantilevered beam.

Generally speaking no structural engineering analysis and design software is perfect. Understanding the methodology and assumptions used by the software and the default settings available is crucial to efficiently and effectively use the program to design building structures. That said, manual checks of computer results are essential to verify the accuracy of the analysis.

5.3 Verification and Validation

5.3.1 General

Good engineering does not merely involve being proficient with using engineering software. Good engineering requires validation of computer analysis. Good engineering also requires designers to creatively configure efficient and constructible framing systems before they even perform their computer analysis.

Verification and validation represents a term for the complete range of checks that are performed on a system in order to increase confidence that the system is suitable for its intended purpose.

Verification is a quality control process that is used to evaluate whether or not a product, service, or system complies with regulations, specifications, or conditions imposed at the start of a development phase. Verification can be in development, scale-up, or production. This is often an internal process. Verification can be described as, “are you building the thing right?” “Building the right thing” refers back to the user’s needs, while “building it right” checks that the specification be correctly implemented by the system. Verification is a process that makes it sure that the model is developed the right way. The model should confirm to its predefined specifications, as the model development goes through different stages, and analysis is done to ensure that all required specifications are met.

Validation is defined as “answering the question whether the customer will be able to use the product in its intended manner. It is defined as something is to test it for use, not to check it for

physical properties. It is quality assurance process of establishing evidence that provides a high degree of assurance that a product, device, or system accomplishes its intended requirements. This often involves acceptance of fitness for purpose with end users. It is sometimes said that validation can be expressed by the query "Are you building the right thing?" Validation is the process of checking if something satisfies a certain criterion. For examples it refers to checking if a statement is true, if an appliance works as intended, if a computer system is secure, or if computer data are complaint with an open standard. Validation implies one is able to document that a solution or process is correct or is suited for its intended use. Validation confirms that the needs of an external customer or user of a product, service, or system are met. Validation can mean to declare or make legally valid or to prove valid or confirm the validity of data, information, or processes. Validation is defined as "Confirmation, through the provision of objective evidence, that the requirements for a specific intended use or application have been fulfilled"

The creativity and solutions to structural engineering challenges come from the mind and imagination of the structural engineer, not the computer. Manual calculations and tips and techniques for verifying the accuracy of computer analysis and design are important. Software limitations and assumptions are reviewed with continual emphasis that computers are tools to be properly used by engineers.

5.3.2 Verification of Structural Design Results

Due to the complexity of structural loads, construction materials, and analysis/design methods as well as the governing codes, structural design for certain real world structures could be very demanding and involved. The whole design procedure may last for a significant length of time. Loading conditions, structural layouts, construction materials, design assumptions, code requirements, etc. may change with the progress of the project. The analysis and design of the structure could be very lengthy and fragmented. The robustness of final results of the structural design relies on the accuracy of every step of the procedure. Therefore, for a structural engineering design firm to minimize the liability risk in design, an effective yet reliable approach to verification of the design product is a vital necessity.

Since the designer of a structure is the person directly involved in all steps and all aspects of the whole design procedure, a rigorous self-checking should be the first essential verification approach. Based on a designer's experience and the scope of the subject project, a check-list of self-checking items such as:

- design codes compliance,
- loading types,

- load combinations,
- structure types,
- member properties and connections/supports,
- computer input and structural modeling,
- analysis methods,
- design criteria and assumptions, etc.

may become a routine list for easy and effective verification of each design step. For certain hand-calculation items, double checking significant equations and where the results were used should become a fundamental customary practice. A well-organized compilation of all design references and calculations will serve as an extremely useful tool for verifying design results.

The second verification approach should be a well-organized peer-review. Guidelines for peer-review shall be established to avoid viewer's negligence or error.

5.3.3 Validating the Results of Structural Engineering Software

Engineers use computers because they can perform repetitive analysis and design calculations thousands of times faster than if performed manually with a calculator and pencil. Obviously, if the wrong data is entered into the computer, the results will be incorrect. The purpose of validating a computer generated design with manual computations is to verify that data was entered into the program correctly, and that the software is employing rational and valid methodologies for design and analysis.

The goal of performing manual calculations to verify computer generated design is not necessarily to match the precise design provided by the computer analysis, but rather to get an answer that is comfortably close to the design provided by the program. As a general rule, if quick manual computations are within approximately 10 percent of the results provided by the software, it is reasonable to assume that the computer analysis and design is correct. However, if manual computations differ from computer results by more than 20 percent, then there is a high likelihood that an error was made somewhere. Errors in computer-generated designs are usually the result of incorrect input, incorrect understanding of program default settings or lack of understanding as to how the software works.

The first thing an engineer should do when reviewing a computerized design is to step back, look at the big picture and ask, "Does this make sense?" Although this might seem so obvious as to not warrant stating, it's something that often does not happen. The engineer verifying if a computerized design "makes sense" obviously has to be an engineer with some level of experience. No structural engineering firm should ever allow a computer generated design

produced by a junior level, inexperienced engineer to leave the office without a review by a senior level engineer.

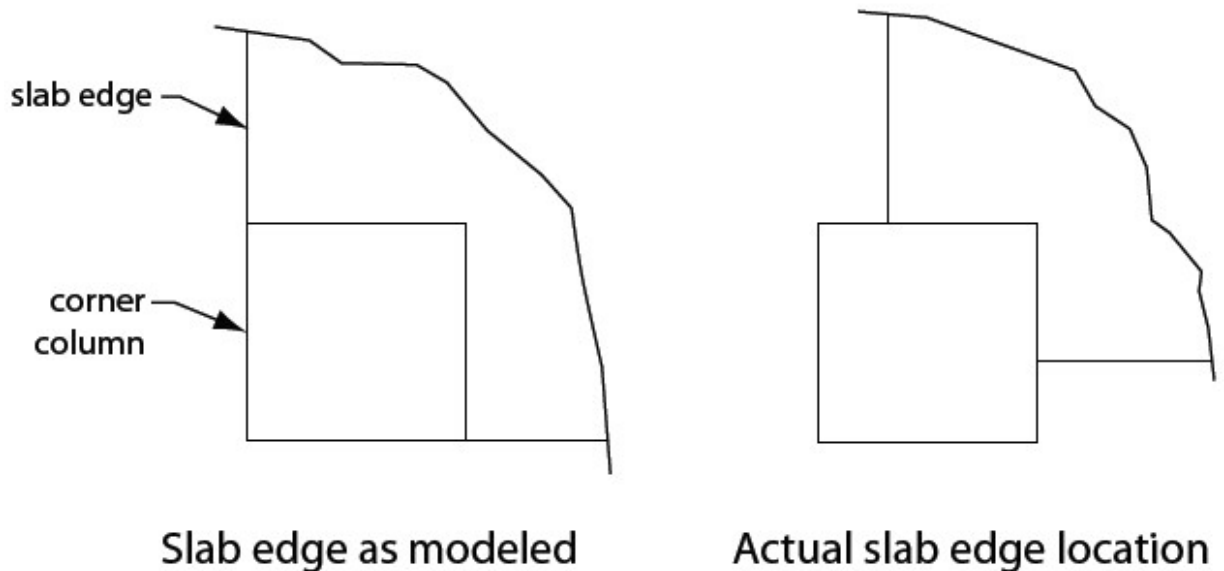

Figure 8 Illustration of discrepancy between slab edge as modeled and actual slab edge location

Validating design of gravity load framing

The strategy for validating the design of floor framing plans is to manually design one typical slab, beam, girder, column and foundation. If the manual design for these members closely matches the computer-generated design, then there is a high likelihood that the computer input, analysis and results for the other gravity framing members are correct. Manual design calculations should also be performed to review the design of critical members such as transfer girders. If the manual calculations do not closely match the computer output, then the model should be investigated for errors.

Printing reactions on structural steel floor framing plans can be extremely beneficial for verifying that the correct design loads were used. Manually computed reactions for typical beams and girders should closely match the computer generated values. Printing the reactions on steel framed floor plans allows the engineer to see the flow of the load through the structure. Mistakes that are commonly made when using a computer program to design gravity framing include not counting or double counting the structure self-weight (a software default setting) and not using or improperly using live load reductions and improperly assigning design loads. The accuracy of computer-generated designs is also highly dependent on the geometry that is defined by the user. Figure 8 shows a corner column in a concrete flat plate floor. On the left is the slab edge as

modeled. On the right is the final required slab edge location. Architectural refinements such as slab edge locations often occur when the structural design is almost complete. In the situation illustrated in Figure 8, moving the slab edge in from the faces of the column can result in significant loss of punching shear strength at the slab-to-column connection. Architectural changes such as this must be updated in the structural model to investigate what impact they have on the structure.

Validating design of the lateral force-resisting system

The multitude of building code-mandated load cases and combinations makes manual review of computer-designed lateral load resisting systems a bit more complex than manual review of gravity load framing systems.

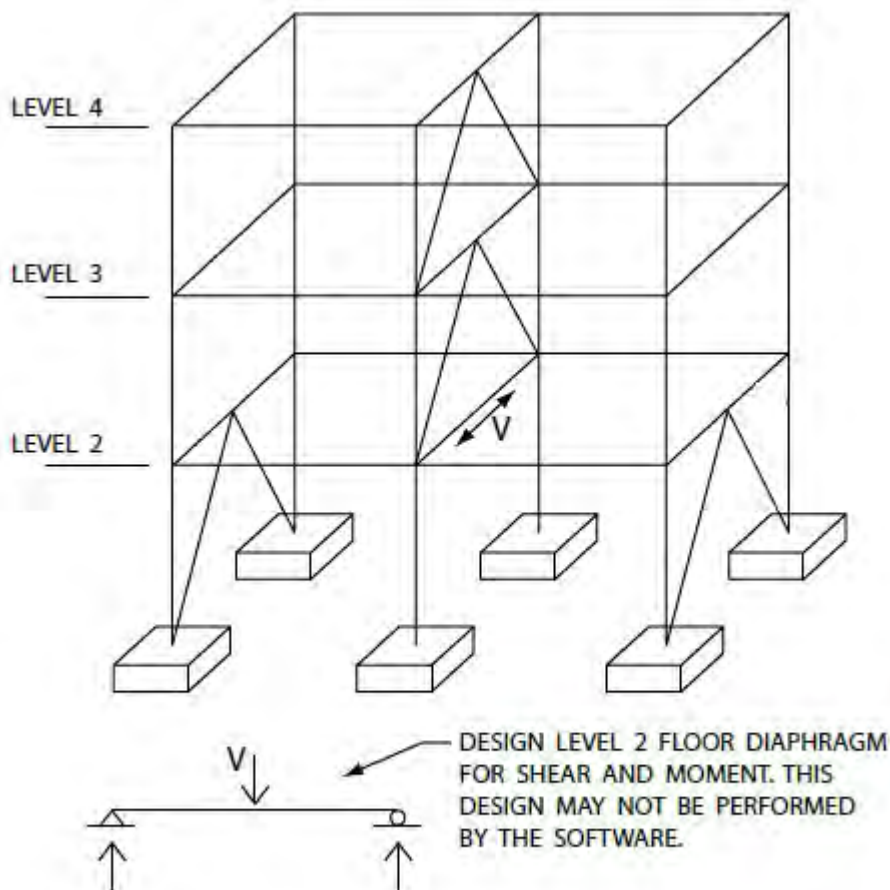

Figure 9 Illustration of a structural member (floor diaphragm) not designed by the software

While the complexity of precisely analyzing the various wind load cases and seismic load combinations is daunting, there is a way to quickly compute wind and seismic forces on regular shaped building structures to a level of accuracy sufficient for verifying designs produced by computer software.

The following procedures, while not precise enough for design, are generally accurate enough to verify that the computer results are correct for regular shaped buildings of low to moderate height. These procedures will flush out significant errors that might otherwise have slipped by had manual computations not been performed to validate the computer-generated results.

Validating the magnitude and distribution of wind loads

Investigating wind loads in each orthogonal direction. (This is the basic wind load case. Investigate other load cases if appropriate for buildings with unusual geometries or framing configurations.)

Compute wind pressure (windward and leeward) at the base of building and roof.

Interpolate linearly from ground level to roof.

Compute the average pressure.

Compute the total wind load base shear.

Distribute wind loads to the lateral force-resisting elements in proportion to their tributary area. (Modify distribution where stiffnesses of lateral force-resisting elements vary significantly.)

Analyze braced frames, moment frames or where walls using the proportioned wind load.

Validating the magnitude and distribution of seismic loads

Investigate seismic loads in each orthogonal direction.

Compute the base shear in each direction using the computer calculated building period, T .

Compare the manually calculated value to the base shear determined by the computer analysis.

Distribute the load in a triangular load pattern (centroid of loading located two thirds of the building height above the base)

Distribute loads to the lateral force-resisting elements in proportion to the tributary mass around each element.

Analyze braced frames, moment frames or shear walls using the proportioned lateral load.

The procedures above will generally be accurate enough for regular shaped buildings of moderate height in areas of low to moderate seismicity within a level of accuracy that will catch significant errors in a computer analysis.

A common mistake with computer design of lateral force-resisting systems is the failure to consider load path issues where lateral loads pass through floor diaphragms from one lateral force-resisting element to another. Figure 9 illustrates a condition where an out-of-plane offset irregularity in a braced frame transmits lateral loads into the floor diaphragm. While many software programs allow floor slabs to be assigned as diaphragms, not all programs will design the diaphragms. Validation of the computer's results in these situations requires recognition of which structural members may not have been designed by the software.

Validating computer-generated structural design with manual computation is essential and can be accomplished quickly within an acceptable level of accuracy using rudimentary calculations. While those calculations may not be to a level of precision accurate enough for design, they are usually accurate enough to help engineers spot errors in a computer model.

5.4 Minimum Requirements for Computer Related Quality

There is a clear and present danger of computer misuse which is causing serious degradations of structural engineering quality and increasing threats to the safety of the public. This state of practice demands that extreme caution be exercised when using computers as a vehicle for automated structural analysis and design, and requires increased attention on the part of professional engineering societies and government regulators in regard to the use of computers by civil engineers in general, and structural engineers in particular. Therefore, in order to assure that the environment of computer use by structural engineers has a minimum level of quality, it is critical that:

1. No Computer software product should be considered for purchase without properly qualifying and certifying the vendor of the software.
2. No computer software product should be used for structural engineering computations unless it has been fully and properly validated and certified pursuant to industry accepted standards of engineering software QA and QC.
3. The structural engineer must apply the same high degree of care and detail when validating computer software accuracy and checking actual computer results as is applied when using time tested and traditional procedures for checking hand computations (e.g., every detail, data value, assumption, and computation must be checked and rechecked prior to use).
4. The structural engineer must use his/ her best judgment and his/her full depth of knowledge and range of experience when using the computer. Persons without sufficient structural engineering knowledge and experience which would qualify them to be fully and legally responsible for structural engineering designs should not be allowed to use the

computer software without careful and complete supervision by a competent, experienced, knowledgeable, and responsible structural engineer. ***In other words, a good computer program does not make a good engineer, only a good engineer should use a good computer program!***

5. Engineering management must be more concerned about the quality of structural engineering computation than ever before when the computer is involved. Engineering managers must set examples and provide incentives and comprehensive training programs for the proper use of computers in the structural engineering design decision-making process. Those managers who trade away quality of engineering in return for assumed increases in productivity and profitability through the use of the computer are only fooling themselves, their companies, and their clients. It takes a major commitment and upfront investment of people, time, and money in order to reap the benefits of computers. There is no easy path to success and profit.
6. The engineering education community must recognize the urgent need to include in their curricula the issues of how the computer environment impacts areas of engineering liability, quality of engineering computations, procedures for assuring software quality, and qualifications of engineering computer professionals.
7. Professional engineering societies must establish and aggressively promote guidelines for the proper use of computers by structural engineers. There is a clear and present danger of computer misuse which is causing serious degradations of structural engineering quality and increasing threats to the safety of the public.
8. Government regulatory agencies that are charged with assuring the safety of the general public must develop regulations (and appropriate penalties) to protect the public from the dangers of improper use of computers in structural engineering analysis and design.

6. CONCLUSIONS AND RECOMMENDATIONS

Structural designs are given a little attention in the city to such an extent that a collection of junk files with erroneous analysis and design data are submitted for approval, merely for the simple purpose of formality and getting a go on permission.

Added to the above carelessness and blind acting, the city's administration has no any consistent quality assurance program to control and check the structural designs, which broadens and encourages the carelessness act in the design offices with a sense of "who will ask me?"

Unless a revolution is taken place in the doing as well as thinking of the structural design community, catastrophic failures and consequent damages are inevitable with the growing number of high rise buildings in the city. This situation is worsened by the fact that Addis Ababa and many important cities in the country are near the rift valley which makes them earthquake susceptible.

As it is of no use crying over spilt milk, policy makers and the city's administration has to give a due attention to the spoiled structural engineering culture before regrettable calamities befall on citizens' life and country's economy.

It is difficult for the city's administration to check all structural designs, with a detailed checklist as prepared in this paper. So the responsibility has to be given for private firms by providing them with special license given after detailed study of their proficiency for this great responsibility.

In every case specialized professionals have to be used for major, important, and postgraduate course needing works. Therefore using structural engineers is also to be emphasized for the concerned structures.

As all competent and experienced engineers are aware, no good computer program can make a competent structural engineer, only a competent engineer should use a good computer program. Although this may seem self evident, it sadly is not the reality of how computers are being used in practice today. Thus every stakeholder has to expose the dangers and to create and implement the protections in relation to computerized environment in the field.

Associations such as EACE and others one of whose aim is to strengthen the quality and reliability of the profession in the country has to work hard for their goal.

REFERENCES

- AACA. "ADDIS ABABA CITY ADMINISTRATION: WEREDAS CREATED FROM EXISTING KEBELES AS PER THEIR SUB-CITY". Addis Ababa, 2010. Addis Ababa.
- AAICA, 2001. *Construction License Permit Guideline 2/2001*. Addis Ababa: Addis Ababa City Administration.
- Abatemam, A. & Dinku, A., 2007. Assessment of Delays in Ethiopian Public Building Construction Projects Executed by Local Contractors. *EACE Journal*, 4(3), pp.1-16.
- Anon, a. Outsourcing Structural Design. Available at:
<http://outsourcingstructuraldesign.blogspot.com/2010/09/quality-assurance-for-structural-design.html> .
- Anon, b. Software Quality. Available at:
http://searchsoftwarequality.techtarget.com/sDefinition/0,,sid92_gci816126,00.html.
- Balci, O., 2003. Verification, Validation, and Certification of Modeling and Simulation Applications. In *Proceedings of the 2003 Winter Simulation Conference*. pp. 150-158.
- COOLTRON, 2010. Quality Assurance Manual. COOLTRON Industrial Supply, Inc. Walnut, USA.
- En, B.S., 2002. Euro code - Basis of structural design. *Management*, 3.
- FDRE, 2009. Ethiopian Building Proclamation 624/2009. *Federal Negarit Gazeta*, 15(31), pp.4673-4700.
- ISO, 2010. International Organization for Standardization. *International Standards for Business, Government and Society*. Available at: <http://www.iso.org/iso/about.htm>.
- MoWUD, 1995. EBCS- 1 Ethiopian Building Code Standard: BASIS OF DESIGN AND ACTIONS ON STRUCTURES. *Building*.
- Murphy, B. & Wakefield, A., Early Verification and Validation Using Model-Based Design. *The Math Works Inc*. Available at:
www.eetasia.com/STATIC/PDF/.../EEOL_2010JUN16_EDA_TA_01.pdf?
- MWUD, 2002. Total Consultants List. Ministry of Urban Development and Construction, Addis Ababa.

- OGCIO, 2008. Quality Assurance Review Procedure. *Office*.
- Schwinger, C., *Quality Assurance for Structural Engineering Firms*, Available at: www.modernsteel.com/uploads/FullFiles/Schwinger.pdf .
- Schwinger, C., 2010. Your Article is Amazing. *Email Received*. Available at: My yahoo account.
- Schwinger, C. & Meyer, A.J., 2010. Tips for Reducing RFIs. *Quality Assurance Corner*, pp.42-43. Available at: www.structuremag.org/article.aspx?articleID=1071.
- Senbetta, E., 2011. I greatly appreciate your effort and motive! Available at: My yahoo account.
- Stewart, M.G., 1989. Checking Models in Structural Design. *Journal of Structural Engineering*, 115(6). Available at: <http://cedb.asce.org/cgi/WWWdisplay.cgi?60840>.
- Taye, S., 2008. Inhouse Quality Assurance for Architectural and Engineering Consulting Firms. *EACE Bulletin*, 7(4), pp.1-7.