



**ADDIS ABABA UNIVERSITY**

**SCHOOL OF GRADUATE STUDIES**

**ADDIS ABABA INSTITUTE OF TECHNOLOGY**

**SCHOOL OF ELECTRICAL AND COMPUTER ENGINEERING**

**Deployment of Long Term Evolution (LTE) Femtocells in  
Dead Zone Areas**

**By**

**Dejene Hurissa**

**Advisor**

**Dr. Yalemzewd Negash**

**A thesis submitted to the school of Graduate studies of Addis Ababa**

**University in partial fulfillment of the requirements for the degree of**

**Masters of Science in Communication Engineering**

**December 2014**

**Addis Ababa, Ethiopia**



**AAiT**

Addis Ababa Institute of Technology  
አዲስ አበባ ቴክኖሎጂ ስኬል  
Addis Ababa University  
www.aait.edu.et

**ADDIS ABABA UNIVERSITY**

**SCHOOL OF GRADUATE STUDIES**

**ADDIS ABABA INSTITUTE OF TECHNOLOGY**

**ELECTRICAL AND COMPUTER ENGINEERING DEPARTMENT**

**Deployment of Long Term Evolution (LTE) Femtocells in  
Dead Zone Areas**

**By**

**Dejene Hurissa**

**APPROVAL BY BOARD OF EXAMINERS**

\_\_\_\_\_

*Chairman, Dept. of Graduate*

**Committee**

\_\_\_\_\_

*Advisor*

\_\_\_\_\_

*Internal Examiner*

\_\_\_\_\_

*External Examiner*

\_\_\_\_\_

*signature*

\_\_\_\_\_

*signature*

\_\_\_\_\_

*signature*

\_\_\_\_\_

*signature*



**AAiT**

Addis Ababa Institute of Technology  
ላላ ላላ ስቴሪት ላ ማይ-ቲ-ቲ  
Addis Ababa University  
ወንጌ ላላ ስቴሪት

## Declaration

I, the undersigned, declare that this thesis work is my original work, has not been presented for a degree in this or any other universities, and all sources of materials used for the thesis work have been fully acknowledged.

Dejene Hurissa Boku

\_\_\_\_\_

*Name*

*signature*

Place: Addis Ababa

\_\_\_\_\_

*Date of submission*

This thesis has been submitted for examination with my approval as a university advisor.

Dr. Yalemzewd Negash

\_\_\_\_\_

*Advisor's name*

*Signature*



# Abstract

---

The aim of this thesis is to investigate the use of femtocells deployment for indoor users under long term evolution (LTE). LTE is currently under deployment in Addis Ababa to support the high traffic demand of devices. Addis Ababa as a capital city of Ethiopia has got different big buildings, companies, hotels, hospitals, condo, and residential houses etc. Most of the calls and data services like exploring internet will take place indoors. Although LTE is the latest technology, due to different signal attenuation factors like the number of walls, the number of floors, furniture's and others, the need of subscribers are not fulfilled yet. For this reason femtocells are taken as a solution, with the aim of enhancing the capacity for indoor users. They are new technological advances, which are used to significantly boost cellular network performance especially in indoors.

Firstly, this thesis is intended to give good understanding of LTE technology and femtocells. In the second stage several femtocells deployment constraints are studied along with the proposed flow chart. These constraints are spectrum allocation, handover, interference, mobility and give some ideas for how to overcome them. Jamo condo was taken as a sample for performance analysis using Multi Wall Multi Floor (MWMF) indoor propagation model. Finally this thesis work could be investigated by comparing the performance of LTE with and without femtocells deployment using MATLAB.

The performances of femtocells are discussed based on specific key performance indicators (KPI). Accordingly path losses, received power, signal to interference plus noise ratio, data rate and power control are performance measurements used in this thesis. The results of the experiment show that femtocells are well suited for enhancing network capacity for indoor users. However, unable to be done based on real deployment due to absence of femtocells in all buildings of Addis Ababa. This thesis work recommends further study of the femtocells technology for increasing the data rate in certain dead zone areas other than indoors.

**Key words:** LTE; femtocells; deployment considerations



**AAiT**

Addis Ababa Institute of Technology  
አዲስ አበባ ቴክኖሎጂ ስራ ቤት  
Addis Ababa University  
www.aait.edu.et

# Acknowledgment

---

All praises and thanks to Almighty GOD, the most beneficent and the most merciful, who gave me abilities and helped me to complete this thesis. Next to that I would like to thank Addis Ababa University for giving me the chance of broadening my knowledge in my carrier. Moreover, the science of Electrical and Computer Engineering has given me the freedom to research issues and thus have had the possibility to finalize my thesis. I owe special heartfelt gratitude to my advisor Dr. Yalemzewd Negash who helped me throughout my work. His suggestion helped me to improve my technical and non technical skills as well. In addition several friends and colleagues have helped me in doing this thesis work through their thoughtful constructive comments and suggestions. All names are unlisted here, but registered in my memory. Thanks to all for encouragement and valuable suggestions.

My appreciation also goes to my instructors, who helped me in understanding the whole course and encouragement so that I wrote this research confidently. Ethio telecom and other companies' fruitful advice, good guidance and comments through my thesis work are unforgettable.

My last not the least thanks would also go to my beloved family for their prayer and friends for their motivation and everlasting love to achieve my goals.



# Abbreviations

---

3GPP	Third Generation Partnership Project
CSG	Closed Subscriber Group
DSL	Digital Subscriber Line
EDGE	Enhanced Data Rate for Global Evolution
EIRP	Effective Isotropic Radiated Power
EPC	Evolved Packet Core
E-UTRAN	Evolved Universal Terrestrial Radio Access Network
FDD	Frequency Division Duplexing
FEC	Forward Error Correction
FFT	Fast Fourier Transforms
GSM	Global System for Mobile Communications
HSPA	High Speed Packet Access
HSPA+	Evolved-High Speed Packet Access
IMT	International Mobile Telecommunications
ISI	Inter Symbol Interference
ITU	International Telecommunication Union
LTE	Long Term Evolution
MME	Mobility Management Entity



**AAiT**

Addis Ababa Institute of Technology  
አዲስ አበባ ቴክኖሎጂ ስራ ቤቅ  
Addis Ababa University  
www.aait.aau.edu.et

MRC	Maximum Ratio Combining
NGMN	Next Generation Mobile Networks
OSS	Operation and Support Subsystem
PAPR	Peak to Average Power Ratio
PDN	Packet Data Network
RB	Resource Block
RRM	Radio Resource Management
RSSI	Received Signal Strength Indicator
SC-FDMA	Single Carrier-Frequency Division Multiple Access
S-GW	Serving Gate Way
STC	Space Time Coding
SINR	Signal to Interference plus Noise Ratio
TDD	Time Division Multiplexing
UICC	Universal Integrated Circuit Board
UMTS	Universal Mobile Telecommunication Service
USIM	Universal Subscriber Identity Module
WCDMA	Wide-Band Code Division Multiple Access
WIMAX	Mobile Worldwide Interoperability for Microwave Access
Wi-Fi	Wireless-Fidelity



# Table of Contents

<b>Abstract</b> -----	i
<b>Acknowledgment</b> -----	ii
<b>Abbreviations</b> -----	iii
<b>Table of Contents</b> -----	v
<b>List of Tables</b> -----	viii
<b>List of Figures</b> -----	ix
<b>Chapter 1: Introduction</b> -----	1
1.1 Background -----	1
1.2 Statement of the Problem -----	2
1.3 Objective -----	4
1.3.1 General Objective -----	4
1.3.2 Specific Objectives -----	4
1.4 Methodology -----	4
1.5 Related Work -----	5
1.6 Contributions -----	6
1.7 Limitations -----	6
1.8 Thesis Layout -----	7
<b>Chapter 2: Long Term Evolution</b> -----	8
2.1 Introduction -----	8
2.2 LTE Network Architecture -----	8
2.3 LTE Frequency Bands -----	10
2.4 Orthogonal Frequency Division Multiple Access -----	13
2.4.1 Subcarriers -----	14
2.4.2 Orthogonality -----	15
2.4.3 Cyclic Prefixes -----	16



2.5 Multiple Antenna Systems-----	17
<b>Chapter 3: LTE Femtocells -----</b>	<b>21</b>
3.1 Introduction-----	21
3.2 Femtocell History-----	22
3.3 Femtocells Basic Elements and Differentiating Femtocells-----	23
3.3.1 Femtocells basic elements-----	23
3.3.2 Differentiating Femtocells-----	23
3.4 LTE Femtocells Standards & Architectures -----	25
3.4.1 Standardization -----	25
3.4.1.1 Timing and Synchronization-----	25
3.4.2 Architecture of Femtocells -----	26
3.5 Access Methods and Energy Saving of Femtocells -----	28
3.5.1 Different Access in Femtocells-----	28
3.5.2 Energy Saving -----	29
3.6 Characteristics of Femtocells -----	30
3.7 Femtocells Self-Organization Requirements -----	30
3.8 Femtocells Configuration at Start-Up -----	31
3.9 Applications and Advantage of Femtocells -----	33
<b>Chapter 4: Femtocells Deployment Considerations -----</b>	<b>35</b>
4.1 Introduction-----	35
4.2 Indoor Propagation Models-----	35
4.3 Proposed Flow Chart -----	38
4.3.1 Selecting a Place to Deploy -----	40
4.3.2 Number of Femtocells and Their Radius -----	41
4.3.3 Scan for Macro Cells Parameters -----	42
4.3.4 Scan for Neighboring Femtocells Parameters -----	42
4.3.5 Calculations -----	42
4.3.6 Mobility -----	45
4.3.7 Ranking Based on SINR -----	46



4.3.8 Handover -----	46
4.3.9 Allocation of the Channels and Threshold -----	48
4.10 Power Control -----	49
<b>Chapter 5: Result and Discussions</b> -----	<b>52</b>
5.1 Performance Evaluation -----	52
5.1.1 Propagation Models -----	52
5.1.2 Received power -----	57
5.1.3 Signal to interference plus noise ratio -----	59
5.1.4 Channel allocation -----	61
5.1.5 Data rate -----	63
5.1.6 Power Control -----	66
<b>Chapter 6: Conclusion and Recommendations</b> -----	<b>71</b>
6.1 Conclusion -----	71
6.2 Recommendations -----	72
<b>References</b> -----	<b>73</b>
<b>Appendix</b> -----	<b>76</b>



# List of Tables

---

Table 1-1: Comparison of data rate.....	2
Table 2-1: LTE frequency bands [FDD].....	11
Table 2-2: LTE frequency bands [TDD].....	12
Table 4-1: Threshold SINR values of femtocells .....	45
Table 4-2: Power control of macro cell .....	50
Table 5-1: MATLAB simulation parameters.....	69



# List of Figures

Figure 1-1: Wireless evolution [1] .....	1
Figure 1-2: Femtocells deployment [18].....	3
Figure 2-1: Evolved E-UTRAN architecture [10] .....	9
Figure 2-2: Evolved packet core architecture [10].....	10
Figure 2-3: LTE frequency band definitions [8].....	11
Figure 2-4: OFDM multiplexing using both FDD and TDD [10] .....	14
Figure 2-5: Spectral efficiency of OFDM [10] .....	15
Figure 2-6: Orthogonal OFDM sub-carriers [10] .....	16
Figure 2-7: Single input multiple outputs [10] .....	18
Figure 2-8: Multiple inputs single output [10].....	18
Figure 2-9: Multiple inputs multiple outputs [10] .....	19
Figure 3-1: Femtocells deployment route [20] .....	21
Figure 3-2: Hierarchy of heterogeneous networks [35] .....	22
Figure 3-3: HeNB gate way aggregates both the control and bearer plane traffic [18] .....	27
Figure 3-4: HeNB gate way aggregates control plane traffic only [18] .....	27
Figure 3-5: Femtocells without HeNB gate way [18].....	28
Figure 3-6: Self optimizing network .....	31



Figure 4-1: Proposed flow chart .....	39
Figure 4-2: Interference cases [36] .....	50
Figure 4-3: Power control .....	51
Figure 5-1(a): Indoor propagation models .....	53
Figure 5-1 (b): Indoor propagation models.....	54
Figure 5-1(c): Path loss of femtocell and macro cell .....	55
Figure 5-1 (d): Path loss of femtocell and macro cell.....	56
Figure 5-1 (e): Path loss of femtocell and macro cell .....	56
Figure 5-2(a): Received power of macro cell and femtocell .....	57
Figure 5-2 (b): Received power of macro cell and femtocell .....	58
Figure 5-2(c): Received power of macro cell and femto cell .....	58
Figure 5-3(a): SINR of macro cell .....	60
Figure 5-3 (b): SINR of femtocell .....	60
Figure 5-3(c): SINR of macro cell and femtocell .....	61



# Chapter 1: Introduction

## 1.1 Background

We are living in the communication generation, massive networking, and internet computing where everything is connected everywhere. Everything is developing fast, new technologies born every day as more capable smart phones and users are getting more experience. Since the introduction of the first mobile network in 1980, the development processes went through many phases and generations driving the mobile network to better performance, coverage, capacity, user throughput and simplified networks for easy deployments and cost reduction [1].

Nowadays many operators are migrating to long term evolution (LTE) to meet the following requirements.

- ✓ A massive growth in the number of connected devices
- ✓ A massive growth in traffic volume
- ✓ An increased wide range of applications with varying requirements and characteristics

Third generation partnership project(3GPP) technologies have evolved from global system for mobile communication(GSM)-Enhanced data for GSM evolution(EDGE), to universal mobile telecommunications system(UMTS)-high speed packet access(HSPA)-evolved high speed packet access(HSPA+), to LTE and finally to long term evolution advanced(LTE-A) in order to provide increased capacity [1], [2]. The figure below shows evolution of wireless networks.

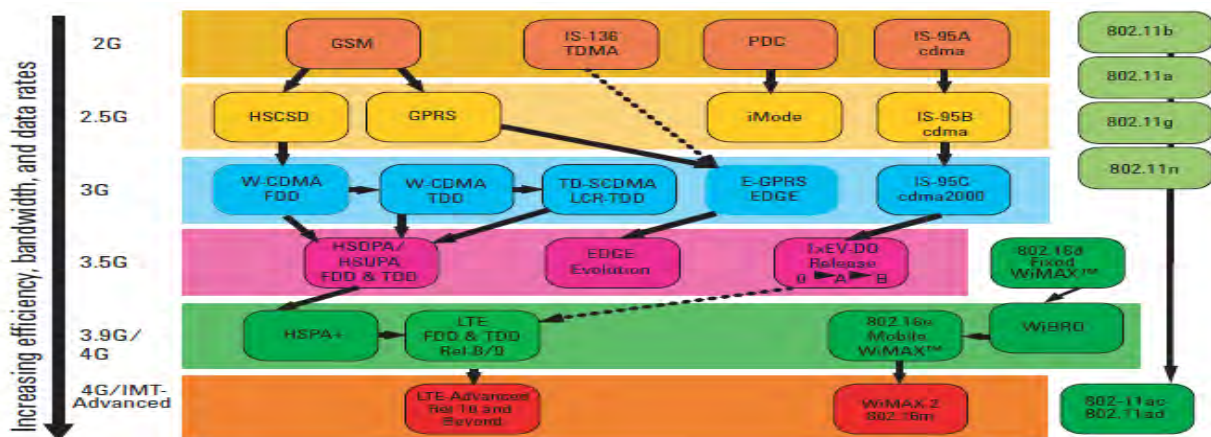

Figure 1-1: Wireless evolution [1]



LTE is being standardized by 3GPP to provide multi-megabit bandwidth, more efficient use of the radio network, latency reduction, improved mobility, and potentially lower cost per bit [3]. The following table shows a comparison of data rate both in uplink and downlink for different technologies.

Table 1-1: Comparison of data rate

Technology	Downlink	Uplink
EV-DO REV A	3.1 Mbps	1.8 Mbps
WCDMA R99	384 kbps	384 Kbps
HSPA	14.4 Mbps	5.76 Mbps
HSPA+	84 Mbps	11.5 Mbps
LTE	326 Mbps	170 Mbps

But with these technology evolutions, the exponential rate of growth in wireless data usage puts further pressure to continued driving innovations into the 3GPP family of technologies. Therefore femtocells are other options for covering certain areas where the cellular network is limited. Femtocells represent a low power, low cost and small range base stations, typically designed for home or small business environment. A femtocell in LTE environment is named as home evolved node base station (HeNB).

The support of high-data rate indoor traffic becomes fundamental. The deployment of LTE composed by femtocells represents the smartest solution for boosting cellular network services especially in indoor scenarios. The benefits expected from deployment of femtocells are increased network capacity and cost reduction. The markets of femtocells are expected to be very attractive for both mobile operators and consumers. For mobile operators they can guarantee a better coverage to those areas which are currently provided with unsatisfactory service if served by macro cells. But femtocells need careful analysis on channel assignment, interferences, handover, and placement.

## 1.2 Statement of the Problem

The recent deployment of LTE network ensures a convergence of most existing wireless mobile communication networks into a universal platform. The capacity of wireless network can be increased by two methods. The first method is by enhancing macro base station functionalities



i.e. using multi carrier aggregation, multiple input multiple output techniques and orthogonal frequency division multiple access. The second one is by using heterogeneous topology which is deployment of small cells under LTE. In addition network capacity can be increased by deploying more LTE base stations. Although the above mentioned techniques enhances data rate, there are certain problems. These problems are:-

- Increasing capacity by deploying more LTE base station is **time** and **money** consumption and in some places it is even hard to deploy.
- Indoor **coverage** and **capacity** issues: Most of the calls and data services take place indoors, but LTE coverage and capacity are insufficient for high data services especially in indoor environments. This is due to different attenuation factors. These factors are number of walls and floors between transmitter and receiver, channel assignment technique, access methods and so on. Figure 1-2 shows indicates where femtocells are deployed.

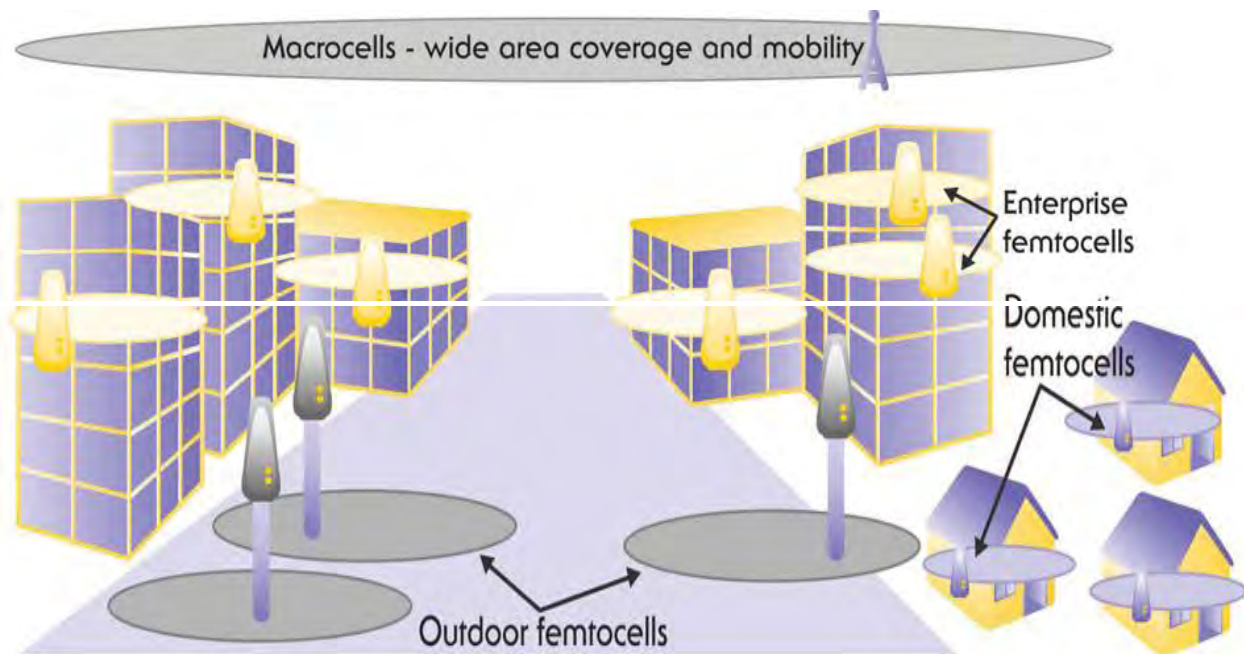

Figure 1-2: Femtocells deployment [18]



## 1.3 Objective

### 1.3.1 General Objective

The aim of this thesis work is to study problems of indoors, and analyze deployment of femtocells. In order to increase the capacity, femtocells are to be deployed and used to serve the indoor users. Furthermore this thesis work is done to indicate the possible improvement of the network performance for indoor users.

### 1.3.2 Specific Objectives

Specifically the purposes of this thesis are as shown below.

- ❖ Describing and study of network problems e.g., study of LTE, study of LTE femtocells, deployment considerations and indoor propagation models.
- ❖ Proposing flow chart for LTE femtocells is also part of this work. In addition it will compare network performance with and without femtocells deployment using MATLAB by taking Jamo condo as a sample. It is done by considering building area, number of walls and floors. Finally the effect of femtocells on the network performance can be analyzed based on results.

## 1.4 Methodology

The techniques (methods) to be used to achieve the objectives of this thesis work are:

- **Literature review:** This will lead to reading different books, different IEEE articles and journals, 3GPP standardization documents, exploring internet, studying MATLAB programming and so on. In addition data collection of LTE parameters for the case of Addis Ababa will be part of this work.
- **System design:** The working principle of LTE femtocells and all constraints to be considered during deployment will be investigated. In addition it includes putting down proposed flow chart for LTE femtocells.
- **Simulation:** It involves transforming the proposed flow chart in to MATLAB programs. This will facilitate the analysis of the KPI.
- **Performance comparison:** It involves performance analysis of LTE cellular network with and without femtocells deployment. Based on results obtained from simulation conclusion can be done.



## 1.5 Related Work

Different contributions and studies have already been done about the use of heterogeneous as a way of improving the performance in relation to homogenous networks. Moreover, several publications discussed the quality of service evaluation over HSDPA, LTE and heterogeneous networks. Many researchers have been done on femtocells as well. Among those:-

- ✓ **Mikko Jarvinen, 2009:** Femtocells Deployment in 3rd Generation Networks

This thesis studied the femtocells business model and simulated the performance and co-operation with the macro layer network. It studied the possible problems in femtocell rollouts and evaluates the status of standardization and available devices. Performance of femtocells was examined by simulations with a widely used radio network planning tool and simulator called ASSET 6. The simulations studied service coverage and throughput. It shows how the coverage is improved by femtocells and how the total network capacity gains can be up to 5 times, compared to the macro layer network only. It is achieved with femtocells implemented on a dedicated carrier.

- ✓ **Chandrasekhar, J. Andrews, and A. Gatherer, 2008:** Femtocell networks: a survey

According to the sequence of received power values from the macro cells user, femtocells user estimates the path loss between itself and the macro cells user.

- ✓ **Jeffrey G. Andrews, Holger Claussen, Mischa Dohler, Sundeep Rangan, Mark C. Reed, 2012:** Femtocells: Past, Present, and Future

This tutorial article overviews the history of femtocells, study their key aspects, and provides a preview of the next few years. The authors believe will see a rapid acceleration towards small cell technology.

- ✓ **Mardeni.R, Siva Priya.T, 2011:** Performance of Path Loss Model in 4G WiMAX  
Wireless Communication Systems in 2390 MHz

This paper outlines how an optimized model for the prediction of path loss for WiMAX signals up to 2390MHz band is developed.

In addition improving fourth generation(4G) coverage and capacity indoors and at hotspots with LTE femtocells was also studied in [26].It is based on real radio network deployment of LTE femtocells. The authors in [21] provide a high-level overview of 3GPP LTE and discusses the



need for some interference management techniques critical for heterogeneous networks. In [30], the authors describe several techniques enabling the move from macro-only to heterogeneous networks and enhanced inter-cell interference management techniques.

In general the major advantages of using heterogeneous network, their technical challenges and research problems are studied as well. This is to show only a few of them.

## 1.6 Contributions

This thesis work conducts the performance analysis of capacity and coverage improvement for indoor users using femtocells. The first contribution starts with studying LTE femtocells which are new technologies in Ethiopia. The steps for deploying femtocells are put down. This can be used as a guideline for deploying femtocells in all types of buildings. Ethio telecom uses repeaters and Wi-Fi for increasing coverage area and capacity for indoor users. But they have certain problems. Wi-Fi and repeaters use unlicensed band which increases the interferences and as a result reduces the capacity. Therefore this study shows how network performance can be improved using femtocells.

This thesis will have a significant study for future researchers of Ethio telecom. It will pave the way to study more and use for better data transfer. The other major contribution of this thesis is that, it will motivate users to use femtocells in different buildings which were not done previously in Ethiopia. The reason is that the entire city of Addis Ababa is under construction. At the time the study will have positive impact on business sectors as communication is one source. Femtocell can be used as the main communication element in all buildings.

## 1.7 Limitations

The study has its focus on the impact of femtocells on the LTE cellular networks in evaluating the network performance. There are certain limitations that inhibit the study of femtocells under LTE cellular network. These limitations are as shown below.

- ✓ The first limitation is that the study will not be taken based on real radio network in Addis Ababa. For LTE cellular network it is possible to plot the coverage area of each base station using **MapInfo professional** and **Google earth**. This can be done by taking data of network parameters from Ethio telecom including longitude and latitude. But this



this work will not compare network performance of LTE with and without femtocells using real deployment approach due to the absence of actual femtocells in all buildings of Addis Ababa.

- ✓ The second limitation of this thesis work is lack of **win prop** software. Win prop software is advantageous over any other software's to analyze the performance of mobile network for indoor users. It will accept AutoCAD file of architectural building and will show the capacity, interference, path loss, received power, signal to interference plus noise ratio, handover etc... of femtocells at each point in the given building. It clearly shows the capacity on each floor and how the signal strength decrease as the number of obstacles increases between femtocells base stations and femtocells users. The software contains different material properties and their losses in its library.

## 1.8 Thesis Layout

The flow of this thesis work is organized or distributed in to six chapters as follows:

**Chapter I** gives the overall introduction and basic concept of the thesis. **Chapter II** covers the main feature of long term evolution. LTE network architecture is included in this chapter as well. **Chapter III** of this thesis discusses femtocells networks and it architectures in detail. This chapter provides relevant background information of LTE femtocells. **Chapter IV** presents all the elements (constraints) of femtocells to be considered while deployment under LTE cellular network. In addition the proposed flow chart and the propagation models are included as well. **Chapter V** highlights the simulation results using MAT LAB programming. Lastly, conclusion and recommendations are covered in **Chapter VI**.



# Chapter 2: Long Term Evolution

## 2.1 Introduction

The technology is evolving at an enormous rate starting from 1<sup>st</sup> generation. LTE is the recent new technology which is used for increasing the data rate. Ethiopia also started using this latest technology at Addis Ababa. LTE is the name given to a project within the 3GPP to improve UMTS mobile system standard to cope with future requirements. The final outcome from this project is a new set of standards defining the functionality and requirements of an evolved, packet based and radio access network [4], [5]. The new radio access network is referred to as the „Evolved UTRAN“ (E-UTRAN). The LTE specification provides downlink peak data rates of at least 100 Mbit/s, and uplink of at least 50 Mbit/s and radio access network (RAN) round-trip times of less than 10ms. LTE supports scalable carrier bandwidths, from 1.4 MHz to 20 MHz and supports both frequency division duplexing (FDD) and time division duplexing (TDD). The main advantages within LTE are high throughput, low latency, higher spectral efficiency, plug and play, an improved end-user experience and a simple architecture resulting in low operating costs. LTE will also support seamless passing to cell towers with older network technology such as GSM, CDMA One, UMTS, and CDMA 2000.

## 2.2 LTE Network Architecture

The LTE architecture consists of the evolved NodeB (eNB), evolved packet core (EPC) and user equipment (UE). The eNB provides the E-UTRA User Plane (UP) and Control Plane (CP) protocol terminations towards the UE. The eNBs are interconnected with each other by means of the X2-interface, e.g. for support of handovers without data loss. The eNBs are connected by means of the S1-interface to the EPC. The S1-interface supports a many-to-many relation between eNBs and mobility management entity/serving-gateway (MME/SGWs) [6], [7]. The high-level network architecture of LTE is comprised of following three main components:

- I. The User Equipment:** The internal architecture of the user equipment for LTE is identical to the one used by GSM, which is called Mobile Equipment. The mobile



equipment comprised of the following important modules:-Mobile Termination which handles all the communication functions, Terminal Equipment which terminates the data streams and Universal Integrated Circuit Card (UICC) also known as the SIM card for LTE equipments.UIC runs an application known as the Universal Subscriber Identity Module (USIM). A USIM stores user-specific data very similar to third generation SIM card. This keeps information about the user's phone number, home network identity and security keys etc...

**II. The Evolved UMTS Terrestrial Radio Access Network (E-UTRAN):** The architecture of UMTS Terrestrial Radio Access Network (E-UTRAN) has been illustrated below. LTE Mobile communicates with just one base station and one cell at a time and there are following two main functions supported by eNB. The eNB sends and receives radio transmissions to all the mobiles using the analogue and digital signal processing functions of the LTE air interface. The eNB controls the low-level operation of all its mobiles, by sending them signaling messages such as handover commands.

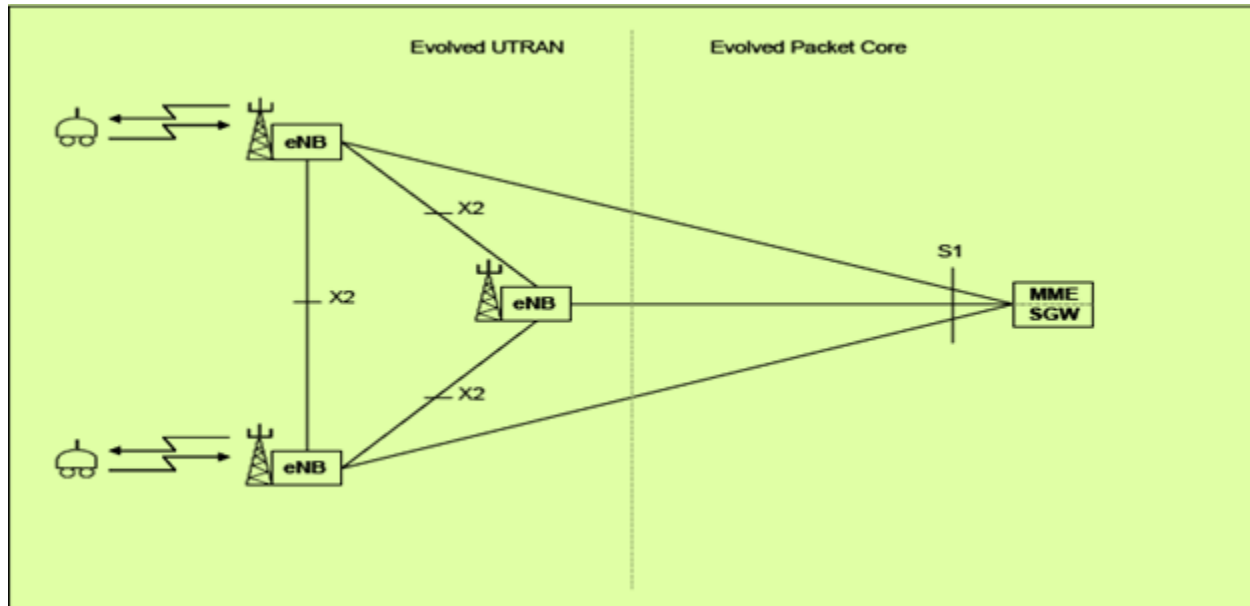
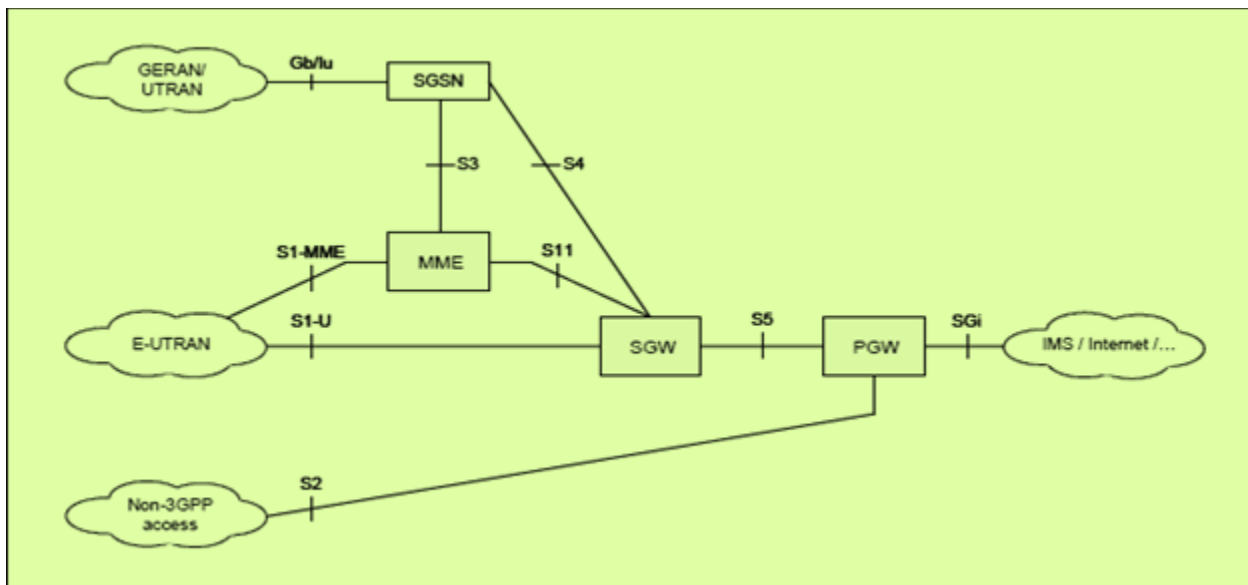

**Figure 2-1: Evolved E-UTRAN architecture [10]**

**III. The Evolved packet core (EPC):** EPC has been illustrated as shown below. The network architecture of the EPC consists of three main nodes.MME, S-GW, and packet



data network-gate way (PGW).The MME connects to the E-UTRAN via the S1-MME interface. It is responsible for handling mobility and security procedures, such as network attach, tracking area updates (similar to location/routing area updates) and authentication. The MME also connects to the serving general packet radio service support node (SGSN) via the S3-interface.The SGW connects to the E-UTRAN via the S1-U interface. Its prime responsibility is routing and forwarding of user IP-packets. P –GW communicates with the outside world i.e.,PDN, using S-Gi interface. Each packet data network is identified by an access point name (APN).

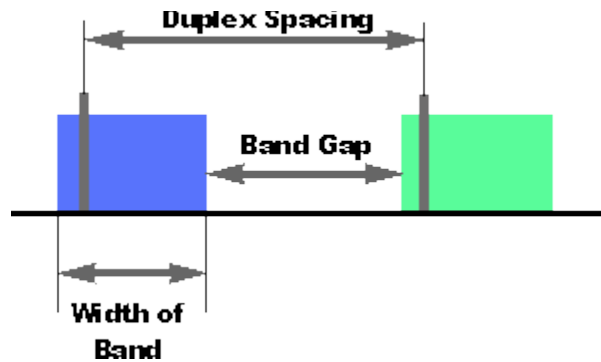

**Figure 2-2: Evolved packet core architecture [10]**

### 2.3 LTE Frequency Bands

There are a growing number of LTE frequency bands. Many of the LTE frequency bands are already in use for other cellular systems, whereas other LTE bands are new. LTE uses frequency FDD and TDD as well. FDD spectrum requires pair bands, one of the uplink and one for the downlink. The FDD LTE frequency bands are paired to allow simultaneous transmission on two frequencies [8]. The bands also have a sufficient separation to enable the transmitted signals not to unduly impair the receiver performance. If the signals are too close then the receiver may be "blocked" and the sensitivity impaired. The separation must be sufficient to enable the roll-off of

the antenna filtering to give sufficient attenuation of the transmitted signal within the receive band.



**Figure 2-3: LTE frequency band definitions [8]**

There are regular additions to the LTE frequency bands as a result of negotiations at the international telecommunication union (ITU) regulatory meetings. These LTE allocations are results from the pressure caused by the ever growing need for mobile communications. The LTE bands between 1 & 31 are for paired spectrum, i.e. FDD i.e.as shown in table 2-1.

**Table 2-1: LTE frequency bands [FDD]**

LTE Band number	Uplink (MHz)	Downlink (MHz)	Width of Band (MHz)	Duplex Spacing (MHz)	Band Gap (MHz)
1	1920 - 1980	2110 - 2170	60	190	130
2	1850 - 1910	1930 - 1990	60	80	20
3	1710 - 1785	1805 - 1880	75	95	20
4	1710 - 1755	2110 - 2155	45	400	355
5	824 - 849	869 - 894	25	45	20
6	830 - 840	875 - 885	10	35	25
7	2500 - 2570	2620 - 2690	70	120	50
8	880 - 915	925 - 960	35	45	10
9	1749.9 - 1784.9	1844.9 - 1879.9	35	95	60
10	1710 - 1770	2110 - 2170	60	400	340
11	1427.9 - 1452.9	1475.9 - 1500.9	20	48	28
12	698 - 716	728 - 746	18	30	12
13	777 - 787	746 - 756	10	-31	41



14	788 - 798	758 - 768	10	-30	40
15	1900 - 1920	2600 - 2620	20	700	680
16	2010 - 2025	2585 - 2600	15	575	560
17	704 - 716	734 - 746	12	30	18
18	815 - 830	860 - 875	15	45	30
19	830 - 845	875 - 890	15	45	30
20	832 - 862	791 - 821	30	-41	71
21	1447.9 - 1462.9	1495.5 - 1510.9	15	48	33
22	3410 - 3500	3510 - 3600	90	100	10
23	2000 - 2020	2180 - 2200	20	180	160
24	1625.5 - 1660.5	1525 - 1559	34	-101.5	135.5
25	1850 - 1915	1930 - 1995	65	80	15
26	814 - 849	859 - 894	30 / 40	-	10
27	807 - 824	852 - 869	17	45	28
28	703 - 748	758 - 803	45	55	10
29	-	717 - 728	11		
30	2305 - 2315	2350 - 2360	10	45	35
31	452.5 - 457.5	462.5 - 467.5	5	10	5

TDD requires a single unpaired frequency allocations band as uplink and downlink on the same frequency but time separated. LTE bands between 32 & 43 are for unpaired spectrum, i.e. TDD as shown in table 2-2.

Table 2-2: LTE frequency bands [TDD]

LTE band number	Allocation(MHz) TDD	Bandwidth
32	1900 - 1920	20
33	2010 - 2025	15
34	1850 - 1910	60
35	1930 - 1990	60
36	1910 - 1930	20
37	2570 - 2620	50
38	1880 - 1920	40
39	2300 - 2400	100
40	2496 - 2690	194



41	3400 - 3600	200
42	3600 - 3800	200
43	703 - 803	100

## 2.4 Orthogonal Frequency Division Multiple Access

Orthogonal Frequency Division Multiplexing (OFDM) is a digital multi-carrier modulation scheme that uses a large number of closely-spaced orthogonal sub-carriers. Each sub-carrier is modulated with a conventional modulation scheme (such as 16QAM) at a low symbol rate, maintaining data rates similar to conventional single-carrier modulation schemes in the same bandwidth[9],[10]. Low symbol rate makes the use of a guard interval between symbols affordable, making it possible to handle time-spreading and inter-symbol interference (ISI). Today, OFDM has proved itself as the preferred radio access technology in a wide variety of communication systems.

### Some advantages of OFDM:

- ✓ Allows adaptation to severe channel conditions without very complex equalization methods
- ✓ Robust against narrow-band co-channel interference
- ✓ Robust against Inter-Symbol Interference (ISI) and fading caused by multipath propagation
- ✓ High spectral efficiency
- ✓ Low sensitivity to time synchronization errors

### Some disadvantages of OFDM:

- ✓ Sensitive to Doppler shift
- ✓ Sensitive to frequency synchronization problems
- ✓ High peak-to-average power ratio (PAPR), requiring more expensive transmitter circuitry and lowering power efficiency.

### 2.4.1 Subcarriers

As it is already mentioned previously, OFDM spreads the data to be transmitted over a large number of sub-carriers- typically more than a thousand. The data rate to be conveyed by each of these sub-carriers is correspondingly reduced, thus transforming a single high bit rate channel to many low bit rate channels. It follows that OFDM symbol length is in turn extended, which dramatically reduces the system's sensitivity to inter-symbol interference due to multipath effects (i.e. different versions, or „echoes“, of the same signal travelling different paths over the radio interface and arriving at the receiver at different points in time, causing interference). This is true as long as the maximum delay of the „echoes“ is smaller than the OFDM symbol time duration. With hundreds or thousands of sub-carriers available it becomes quite straightforward how to multiplex users on the radio interface. Simply allocate different sets of sub-carriers to different users (this is the „FDM“ in OFDM). More complex multiplexing schemes can be implemented by allowing users to share the available sub-carriers both in FDM and TDM.

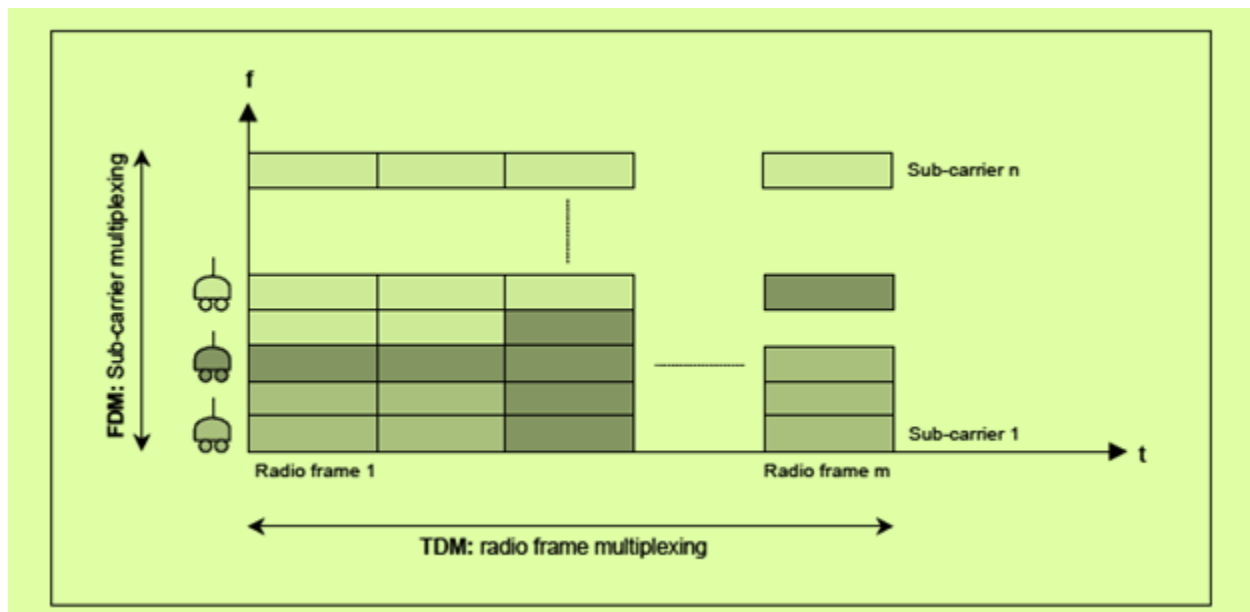

**Figure 2-4: OFDM multiplexing using both FDD and TDD [10]**

Furthermore, sub-carrier frequency hopping schemes may be applied to reduce fading effects that are frequency selective. The transmitter can also order the receivers to send feedback information in the form of channel quality reports. This allows dynamic channel dependent



scheduling in the base station, making sure that each mobile station is always allocated a subset of sub-carriers where it experiences the least amount of interference.

### 2.4.2 Orthogonality

In traditional FDM different users are allocated different frequencies, or channels, for their transmission. To avoid interference between these channels the FDM frequencies must be spaced apart. There must be a guard band between them. This leads to waste of the available frequency spectrum.

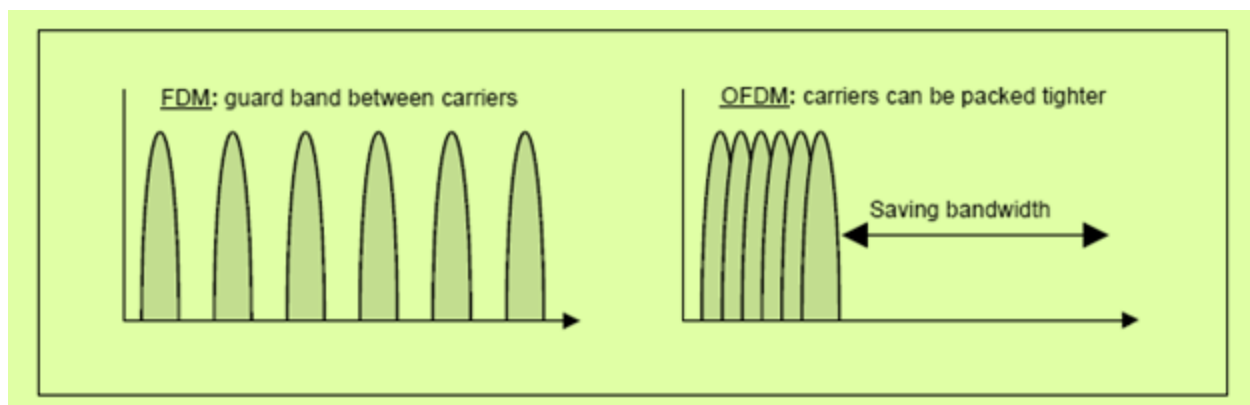
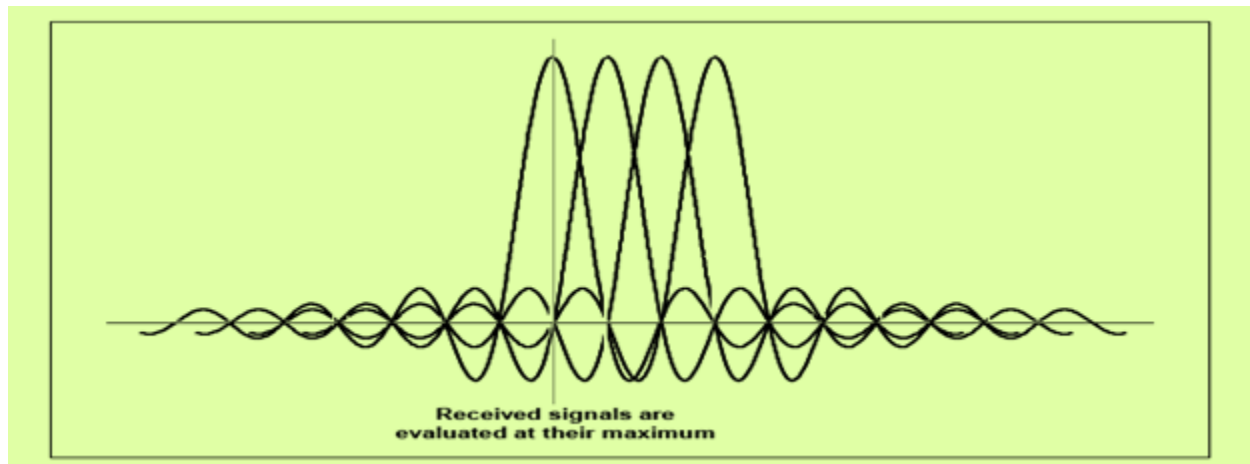

Figure 2-5: Spectral efficiency of OFDM [10]

In OFDM, the frequencies of the individual sub-carriers are chosen in such a way that they do not interfere with each other i.e. they are orthogonal. The demodulator for one sub-carrier does not see the modulation of the others, so there is no crosstalk between sub-carriers even though their spectra overlap. This allows packing the sub-carriers much more densely than in a traditional FDM system, thus increasing spectrum efficiency. All the sub-carriers allocated to a given user are transmitted in parallel. To ensure orthogonality the sub-carriers must have a common, precisely chosen frequency spacing („carrier spacing“). This frequency spacing is exactly the inverse of the OFDM symbol duration, called the active symbol period, over which the receiver will demodulate the signal. In the case of E-UTRA the carrier spacing is 15 kHz.



**Figure 2-6: Orthogonal OFDM sub-carriers [10]**

Figure 2-6 shows a few sub-carriers represented in the frequency domain. The receiver will demodulate (or sample) each sub-carrier precisely where it has its maximum value. Due to the „precisely-chosen frequency spacing“ all other sub-carriers have the value zero at this precise frequency, despite that they overlap, thus not creating any interference at all. However, this nice relationship between sub-carriers can be destroyed, resulting in loss of orthogonality and severe bit error rates as a result. The bit errors can be rectified to some extent with the use of error correcting codes, so called Forward Error Correction (FEC). A combination of FEC and OFDM is called Coded OFDM (COFDM). In E-UTRA, OFDM is combined with Turbo coding. Such loss of orthogonality can be caused by frequency synchronization errors due to slight differences in the local oscillators, used for frequency generation, in the transmitter and the receiver.

### 2.4.3 Cyclic Prefixes

As mentioned earlier, OFDM is robust against multipath fading due to the long OFDM symbol duration. However, there will always be some inter-symbol interference due to multipath echoes, even for OFDM. A further refinement therefore adds the concept of a guard interval. Each OFDM symbol is transmitted for a total symbol period that is longer than the active symbol period by a period called the guard interval or guard period.

This means that the receiver will experience neither inter-symbol nor inter-carrier interference provided that any echoes present in the signal have a delay that does not exceed the guard interval. Naturally, the addition of the guard interval reduces the data capacity by an amount dependent on its length. Different systems use different (relative) lengths of the guard interval,



common values being 5-25% of the OFDM symbol length. There are several ways to „fill“ the guard interval with information (to avoid turning the transmitter on and off abruptly). A common mechanism is the use of a so-called cyclic prefix. A cyclic prefix is created simply by selecting the last part of an OFDM symbol, make a copy of it and place the copy in front of the symbol (hence the term „prefix“). By doing so, a continuous signal is created (easier to implement) and any multipath delayed echoes will only cause interference in the cyclic prefix part of the received OFDM symbol. The receiver treats the cyclic prefix portion of the OFDM symbol as „rubbish“ and removes it prior to demodulating the information. As it is indicated under the disadvantage of OFDM, it has high peak-to-average power ratio (PAPR). This is a direct consequence of using DFT (FFT) to create the OFDM symbols. The DFT effectively stacks sine waves „on top“ of each other. It can then of course happen that a large portion of the used sub-carriers happen to have their maximum value at the same time, resulting in a dramatic peak in the total amplitude (or power) of the signal. This puts very high demands on the power amplifier in the signal processing chain and is not desirable in a small portable device, such as a mobile phone, with limited battery capacity.

The solution for this in the E-UTRA specification is to use a variant of OFDM called Single-Carrier Frequency Division Multiple Access (SC-FDMA) for uplink transmission. The input signal (modulation symbols) will be spread over the available bandwidth (the available sub-carriers) very much like in a single-carrier system.

## 2.5 Multiple Antenna Systems

Any wireless communications system with one transmit (Tx) antenna and one receive (Rx) antenna is referred to as operating in Single Input Single Output (SISO) mode. More antennas (Tx and/or Rx) can be added in order to increase either throughput or reliability. Systems with multiple Tx/Rx antennas are divided into Single Input Multiple Outputs (SIMO), Multiple Inputs Single Output (MISO) or Multiple Inputs Multiple Outputs (MIMO). Multiple inputs multiple outputs is currently used in various WLAN systems (IEEE 802.11 family) and in WiMAX (IEEE 802.16 family) to name a few. MIMO is also an integral part of the 3GPP R8 standards pertaining to E-HSPA and LTE.

### 1.0 Single input multiple output systems

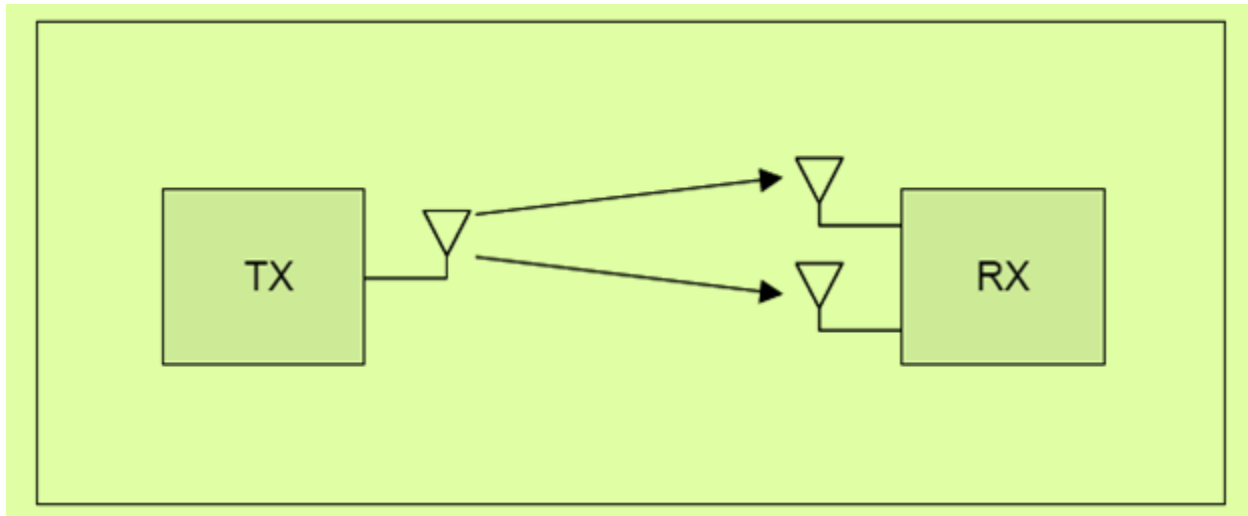

**Figure 2-7: Single input multiple outputs [10]**

In a single input multiple output system the transmitter has one antenna and the receiver has two, or more, physically separated antennas. The physical separation distance has a direct relationship with the wavelength of the carrier. This allows for receiver diversity. With Rx diversity the receiver picks up two (or more) „versions“ of the same transmitted signal. The receiver may then either select the best input from one of the antennas, for example based on signal-to-noise ratio (SNR). This is called switched diversity. Combine the input from all antennas, for example through a process called Maximum Ratio Combining (MRC).

## **2.0 Multiple inputs single output systems**

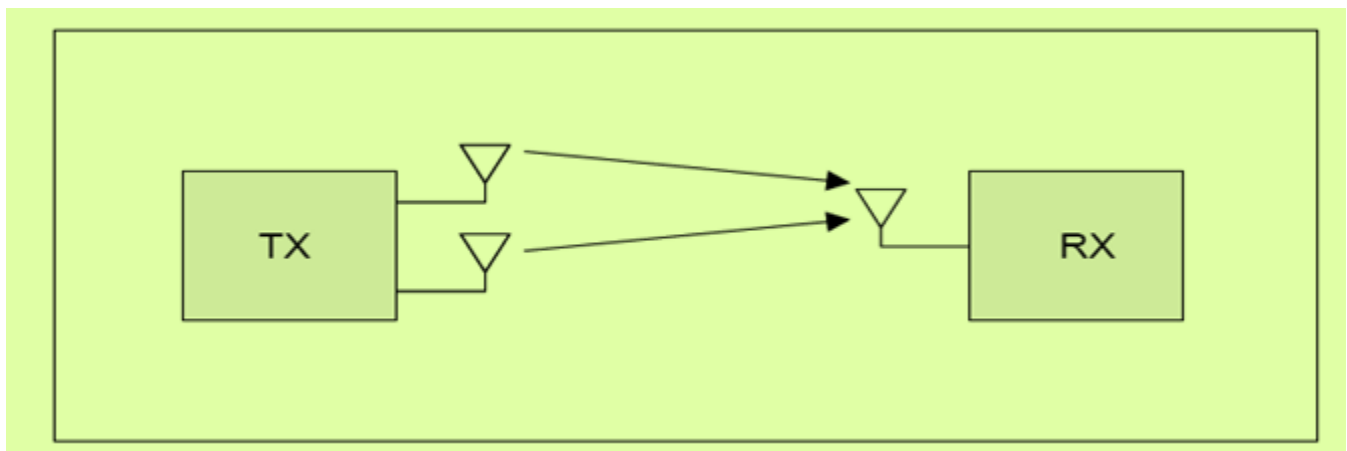

**Figure 2-8: Multiple inputs single output [10]**



In a multiple inputs single output system the transmitter has two or more physically separated antennas and the receiver has one antenna. This allows for transmit diversity (Tx diversity). With Tx diversity, the transmitter sends redundant „copies“ of a signal to the receiver. Tx diversity is based on the „hope“ that at least one of the copies will be received in a good enough state to allow reliable decoding. One way of realizing Tx diversity is to make use of Space-Time Coding (STC).

### 3.0 Multiple inputs multiple outputs systems

It uses multiple antennas at transmitter and receiver. Just like the diversity schemes mentioned above the whole point of using multiple antennas is to increase the system capacity (in terms of number of users/cell, coverage, throughput etc) without having to increase the system bandwidth.

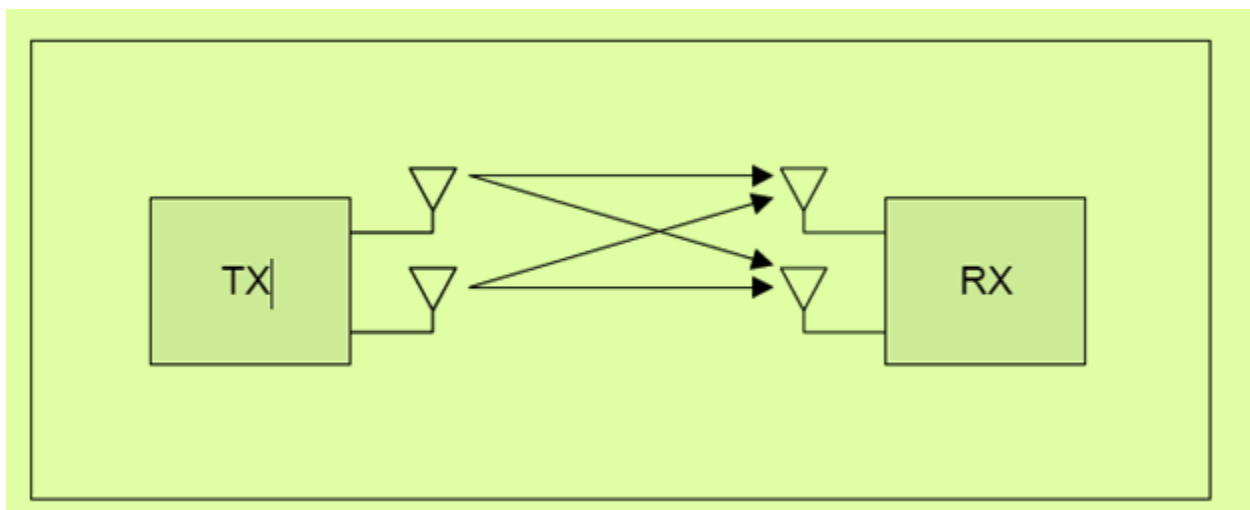

**Figure 2-9: Multiple inputs multiple outputs [10]**

Using the laws of information theory, it can be shown that the diversity schemes in single input multiple outputs and multiple inputs single output increase the system capacity logarithmically with the number of antennas. Symmetric multiple inputs multiple outputs configurations (same number of Tx and Rx antennas) on the other hand, increase the system capacity linearly with the number of antennas. Multiple inputs multiple outputs ability is to take multipath reception, which used to be an unavoidable and undesired by-product of radio propagation, and convert it into an advantage that actually multiplies transmission speed and improves throughput. A multiple inputs multiple outputs system uses the additional signal paths to transmit more information and



recombine the signals on the receiving end. For multiple inputs multiple outputs; mathematical algorithms are used in order to spread the user data across multiple transmitting antennas. The signals transmitted are defined in 3 dimensions: time, frequency and space. At the receiver, the different signals from each antenna must be identified and separately decoded during the recombination process. Hence, the (mathematical) technique of separating out different paths on the radio link is what allows a multiple inputs multiple outputs system to transmit multiple signals at the same time on the same frequency, in effect multiplying the capacity of the channel with the number of antennas.





architecture for indoor coverage and hotspot capacity enhancement [17], [31]. The smallest base station is femtocell as it is indicated in figure 3-2. The main aim of femtocells is to improve coverage and capacity of mobile network by allowing service providers to extend coverage indoors, especially where access would be limited or unavailable. The hierarchical architecture is illustrated in figure 3-2.

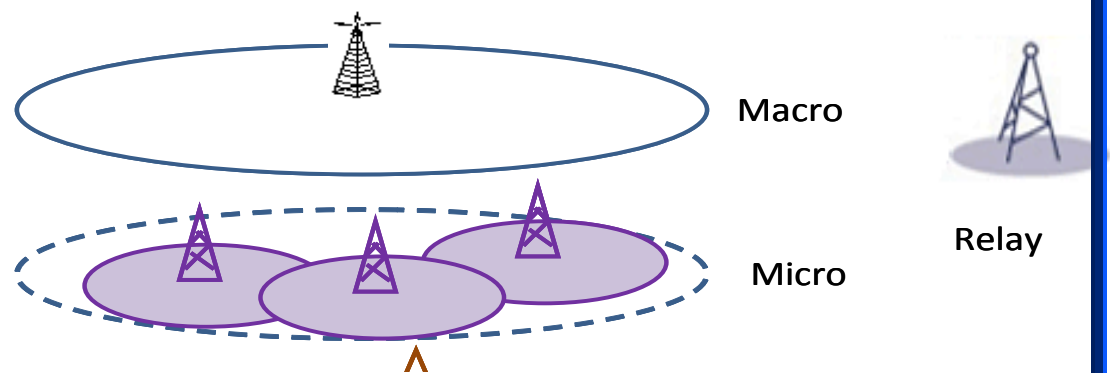

Figure 3-2: Hierarchy of heterogeneous networks [35]

### 3.2 Femtocell History

The first interest in femtocells started around 2002 when a group of engineers at Motorola were investigating possible new applications and methodologies that could be used with mobile communications. A couple of years later in 2004, the idea were beginning to gain some momentum and a variety of companies were looking into the idea. In particular two new companies, Ubiquity's and 3 Way Networks were formed in the UK to address the area of femtocells. With the idea gaining momentum, and many more companies investigating femtocells technology [14]. The Femto Forum was setup in July 2007. Its aim was to promote the wide scale adoption of femtocells. With mounting industry pressure to be able to deploy



femtocells technology, the Femto Forum also played a coordinating role in ensuring that the standards were agreed and released as fast as possible.

### 3.3 Femtocells Basic Elements and Differentiating Femtocells

#### 3.3.1 Femtocells basic elements

The femtocells provide connectivity between the local mobile phones and an internet router. However this is not only part of the overall femtocells system required [15], [16]. Several items are needed:-

- femtocells itself
- Internet router to enable the data to be passed to and from the femtocells via the internet
- Internet link

Various types of femtocells are available on the market. Although individual standards differ in their definitions, the following broad classes can be identified:-

**Class 1:** This is the class of femtocells that emerged first and is currently best known. Femto cells in this class deliver a similar transmit power and deployment view as do Wi-Fi access points (e.g. typically 20 dBm of EIRP or less) for residential or enterprise application. Each delivers typically 4-6 simultaneous voice calls per channel plus data services in an open access fashion to authorized subscribers. Typically, this class of device is installed by the end user.

**Class 2:** Somewhat higher power (typically 24 dBm of EIRP) to support longer range or more users (about 6 – 12). May need to be installed by the operator but end user can also deploy with the operator's assistance.

**Class 3:** Still higher transmit power level for longer range to provide a larger coverage foot print for more users. Typically operators might deploy these outside in an open access mode in built-up areas to deliver distributed capacity, or in rural areas to meet specific coverage needs authorized subscribers.

#### 3.3.2 Differentiating Femtocells

It is very important to differentiate femtocells from other devices. This is because femtocells deployment needs understanding of working principle that makes them unique. Therefore it is instructive to contrast femtocells behavior with several others, specifically Wi-Fi access points, repeater/signal boosters, cordless telephones and conventional cellular base station.



- **Wi-Fi Access Points:** While these also provide wireless broadband access to portable devices, there are important differences. Wi-Fi almost always operates in unlicensed spectrum. In contrast, femtocells operate in licensed spectrum and thereby ensure that an operator is in control of every transmitting device and can manage interference in order to deliver an appropriate quality of service to each user. Wi-Fi access points and client devices all transmit around 0.1W (20 dBm) of power, which does not change even when the device is close to transmitting antenna, thus increasing the chances of interference and battery drainage to the device. By contrast, in cellular technology both the mobile device and femtocells continually adjust their transmit power, a procedure called “power control,” to minimize or maximize the required transmit power.
- **Repeaters/Signal Boosters:** Repeaters are bi-directional amplifiers, used to extend the range and increase coverage area for systems including cellular networks. Repeaters operate by receiving signal from a base station cell site via an external antenna and then amplifying and retransmitting the same signal via radio frequency cables or antennas placed within the area for coverage improvement. They are useful tools in many networks and can certainly improve coverage, but there are many differences from femtocells. Repeaters require careful installation by professionals to guarantee good results. For example, the external and internal installations require proper location and configuration to deliver the appropriate coverage while being isolated from each other to avoid feedback. The gain of the amplifier in the repeater requires proper adjustments to confine it within controlled limits since too little power will fail to deliver adequate coverage improvement, or alternatively too much power will cause feedback and oscillation with the repeater amplifier; thus, degrading or denying service for all the users. By contrast, femtocells are typically “Zero-touch” devices that require no professional skills for setup. In addition, femtocells can be monitored and maintained remotely from the access for the network or by the network’s wireless Base Station Controller.
- **Cellular macro cell base Station:** Femtocells do share much in common with conventional mobile base stations, producing almost indistinguishable signals over the air. However, there are significant differences. Femtocells have limited capacity that is



suitable for a single domestic installation while conventional macro base stations must serve tens or hundreds of users. Macro base stations are therefore professional products, with costs to match, while femtocells are consumer products produced in volume to meet consumer pricing expectations. Femtocells are designed to work with Internet grand backhaul, typically DSL or cable, while macro base stations operate over dedicated backhaul, such as leased lines or microwave links. Macro base stations must be planned and optimized by professional network design engineers while femtocells employ standardized network interfaces and are relatively simple to install. Lastly, femtocells of course radiate at substantially lower levels than a macro base station, being typically around 10,000 times lower.

### **3.4 LTE Femtocells Standards & Architectures**

LTE is the first cellular technology which will be able to take full advantage of femtocells standards from the outset, as the first network deployments take place. LTE femtocells are designed to fit seamlessly into the EPC infrastructure using the same interfaces defined for the macro cells [18], [19]. The same EPC can support a combination of femtocells and macro cells. The remainder of this section provides an update on the status of LTE femtocells standards, describes the architectures available for femtocells deployment, and discusses potential service that can be deployed.

#### **3.4.1 Standardization**

The industry activity on femtocells, considered early in the standardization process of LTE, both by next generation mobile networks (NGMN) in the definition of requirements and by 3GPP in the development of standards from release 8. With the standardization of LTE, it is possible to use 3GPP release 9 for the definition of standards-compliant LTE femtocells. Many solutions defined for wideband code division multiple access (WCDMA) femtocells are being reused for LTE femtocells, such as management and security, which should result in reduced time to market and in reduced costs.

##### **3.4.1.1 Timing and Synchronization**

To keep timing and synchronization, high precision crystal oscillators are used. Zarlink semiconductor company developed IEEE 1588 or network time protocol that can be installed on



the server side(core radio network control) and femtocell access point(client side).When installed on the radio network control, it works like time server. An internal algorithm keeps track of all the access points clock and provides automatic corrections when needed. Every packet sent from the radio network control has a time stamp containing the time that the packet was launched in to the network. In addition when radio network control receives a packet from a femtocell client it automatically returns an acknowledgement message including the reception time of the packet. The femtocell client uses the acknowledgement message as a reference to adjust its own clock.

### **3.4.2 Architecture of Femtocells**

Since LTE is based on flat all-IP architecture, the architecture and interfaces are the same for femtocells as for macro cells.LTE femtocells require no new interfaces to be defined and no changes are required to EPC elements. There are multiple possible architectures for connecting femtocells to the core network. A new optional element, HeNB GW, is defined to provide aggregates S1 interfaces (S1-MME and S1-U), potentially improving the scalability of the core network in regard to femtocells. There are two variations of the HeNB GW defined, with one aggregating the control plane only while the other aggregates both the control and bearer. Figure 3-3 shows the architecture where the HeNB GW aggregates both the control and bearer plane traffic and sends the control traffic to the MME and the bearer traffic to the S-GW.

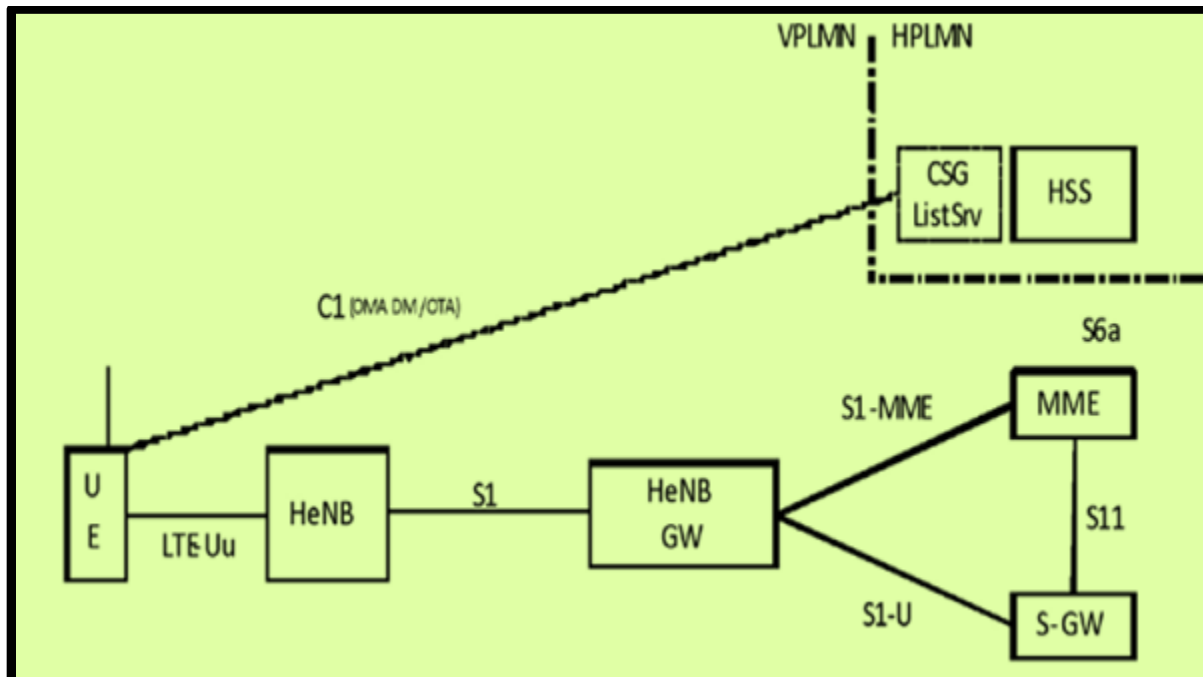

Figure 3-3: HeNB gate way aggregates both the control and bearer plane traffic [18]

Figure 3-4 shows the variant of the architecture where the HeNB GW only aggregates the control plane traffic from multiple HeNBs to the MME.

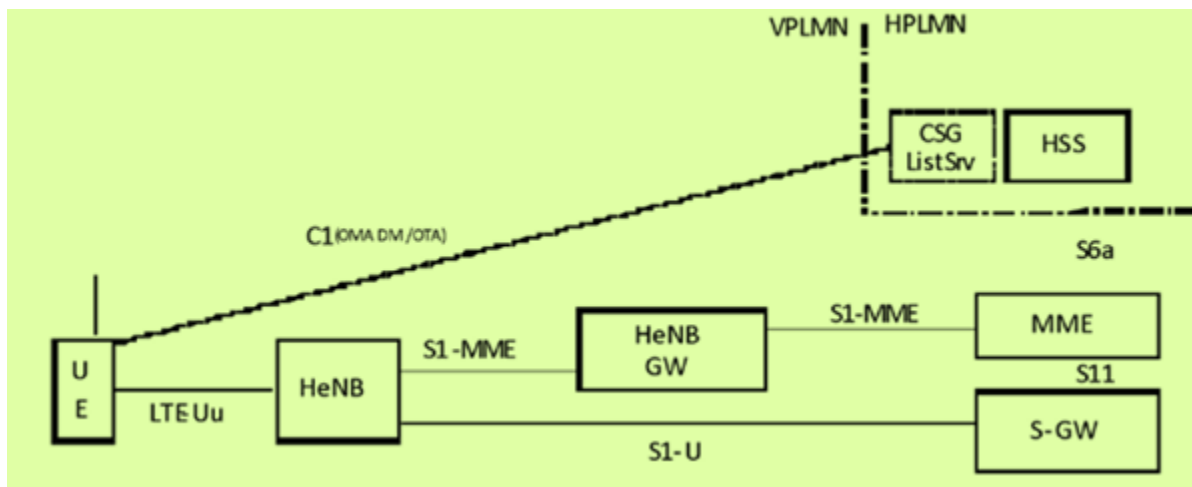

Figure 3-4: HeNB gate way aggregates control plane traffic only [18]

Finally, as stated earlier, the HeNB GW is an optional element and the HeNB can be directly connected to the MME and S-GW, assuming that the MME and S-GW have sufficient capacity to support large numbers of femtocells S1 interfaces.

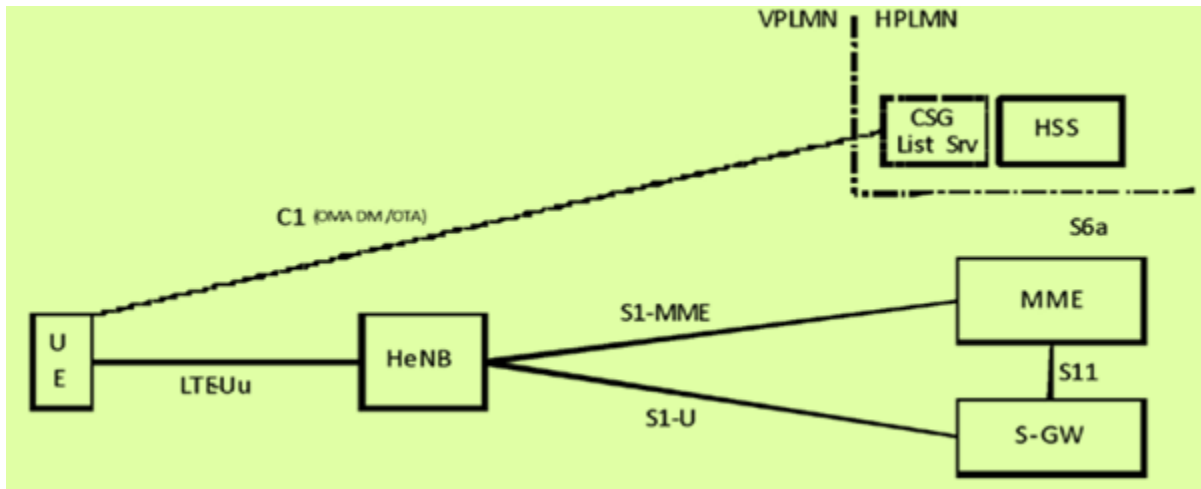

Figure 3-5: Femtocells without HeNB gate way [18]

### 3.5 Access Methods and Energy Saving of Femtocells

#### 3.5.1 Different Access in Femtocells

The interference reduction is an important issue that needs to be addressed. Also, interference generally depends on the type of access control, which controls what kind of user can or cannot connect to the femtocells [20]. The existing access methods for femtocells are:

**Closed Access:** only the users subscribed to the respective femtocells can connect to its base station. These types of base stations are mainly deployed by the private owners. This type of access method leads to a high cross – tier interference. The Third Generation partnership project (3GPP) describes this model as a closed subscriber group (CSG).

**Open Access:** If femtocells are working in the open access mode, then all the users i.e. registered plus nonregistered are able to access the femtocells resources. This makes every user connected to the femtocells at all times, getting the best quality of service. One of the major disadvantages of this type of access mode is the increased number of handovers, and associated signaling overhead.

**Hybrid Access:** A limited amount of femtocells resources are available to all users, while the rest are operated in a CSG manner.



### 3.5.2 Energy Saving

Due to increasing traffic demand, number of base stations have also increased, which is one of the biggest reasons of increase in greenhouse gases in today's time. This in turn also increases the network costs. The base stations alone contribute a carbon footprint of 11 tons of CO<sub>2</sub> [21]. With the increase in the number of base stations it becomes very important to address their energy consumption in a cellular network. Some basic methods to reduce energy consumption due to base stations are as follows:

- ✦ **Reducing base station energy usage:** Improving power amplifier design can be one major way of energy saving. One more method is cell zooming, which includes the increase or decrease of the cell size according to the traffic load. Other than hardware design improvisation, methods like fresh-air cooling can be used in the place of air conditioners, which themselves consume a lot of power.
- ✦ **BS Cooperation:** Traffic load can significantly vary depending on numerous factors like mobility and environment. Traffic load is higher in office areas during day time and in residential areas during the night. This causes cells to have uneven distribution of traffic load. Energy can be increased by shutting down base stations during night times, when the traffic load is quite low in comparison to the day time. About 20% of the energy can be saved by reducing the number of active cells having low traffic.
- ✦ **Use of Renewals Sources of Energy:** In countries like Northern Canada and Africa, cellular networks in remote areas operate on diesel operated generators, which is not only expensive, but also produces CO<sub>2</sub> gas. The consumption of one such generator is about 1500 liters of diesel/month. In places like these renewal sources of energy like solar energy, bio-fuels and, and wind energy can be more viable to reduce the network operator cost. A program called "Green Power for Mobile" has been set up by 25 telecom companies in the favor of use of renewable energy resources, joined under the Global systems for Mobile Communications Association. This program was started with the aim of deploying renewable sources of energy to power base stations.



### 3.6 Characteristics of Femtocells

A femto cell supports all major cellular standard protocols like GSM, CDMA, WCDMA, LTE, WiMAX, as well as all the protocols standardized by 3GPP, 3GPP2 and the IEEE/WiMAX forum [22]. Characteristics of femtocells are:-

- ✓ A femtocells base station works in a licensed spectrum which reserves the resources for only the subscribed users.
- ✓ The transmitting power of a HeNB is very small approximately around 0.1 Watts, thereby decreasing their coverage area as well. But due to this less coverage area, the signal quality i.e. coverage is excellent in its range.
- ✓ A HeNB is connected to the already existing cellular network via DSL lines or cables, using standard Internet protocols.
- ✓ The most significant feature of a HeNB is its plug and play feature. This feature enables the end user or home user to install and start operating just by powering it on. No technical support is required. This process is called self-organizing and self-managing technique.

### 3.7 Femtocells Self-Organization Requirements

Femtocells are required to be able to completely self organize themselves so that there is no intervention from user [22]. This can be split into three main areas:

- 1. Femtocells self organization:** This element of femtocells installation requires the femtocells to be able to select the initial parameters required for operation to commence. These will include the channel, neighbor list, power etc.
- 2. Femtocells self optimization:** once operational, the femtocells will need to monitor the environment to ensure that it takes account of any changes required including the channel and resources required.
- 3. Femtocells self healing:** as problems may occur after set-up, the femtocells will need to be able to resolve any problems that may occur.

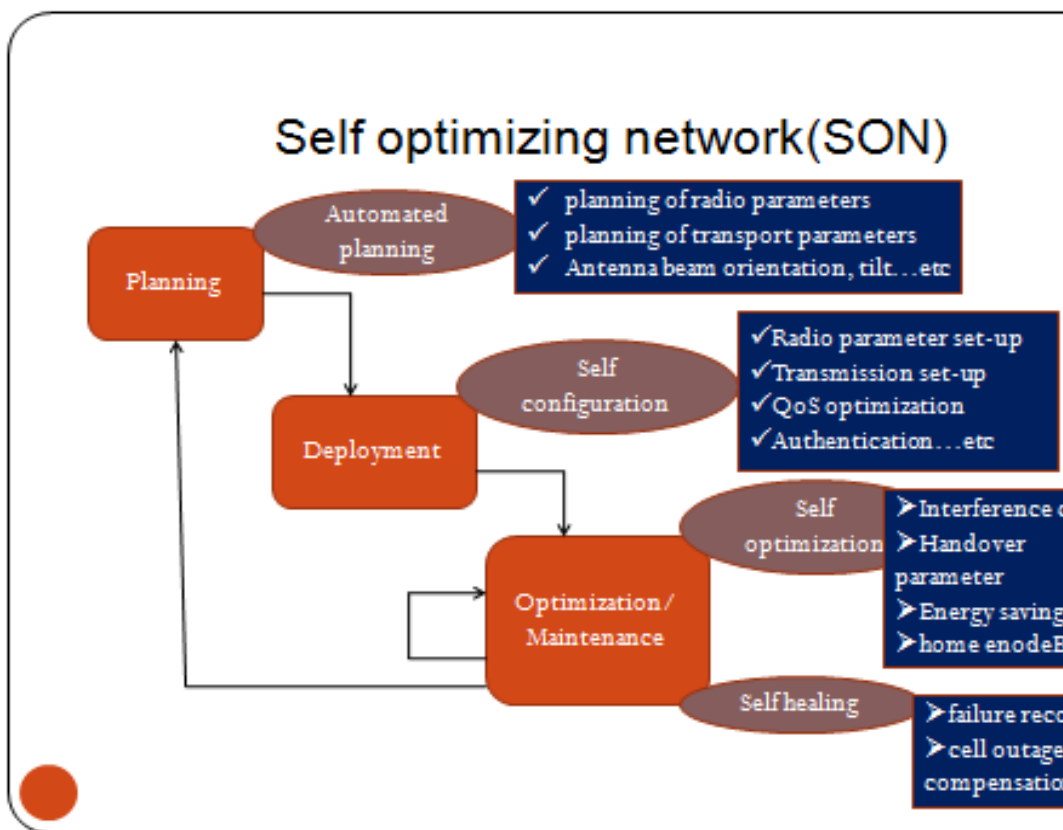

Figure 3-6: Self optimizing network

### 3.8 Femtocells Configuration at Start-Up

One of the key elements of the femtocells configuration occurs at the first start up when the femtocells equipment is being installed. After acquiring, femtocells the customer should only need to plug the femtocells into the power and connect it to the Internet connection to provide



the backhaul connection. With power applied, the first element of the processes is for the femtocells to register within the network. The femtocells will attempt to gain access to the core network via HeNB-GW. To achieve this it will utilize the femtocells ID - a unique identifier given to the each femtocell. With the femtocells successfully registered and the backhaul connection successfully operational, the next stage of the femtocells configuration is to configure the radio interface parameters [23].

There are two main elements to this:

1. **Primary femtocells configuration information:** It includes radio frequency channel information (frequencies for uplink and downlink), Scrambling codes.
2. **Network femtocells configuration information:** It includes the following points
  - ❖ Service area code and information.
  - ❖ Neighbor list.
  - ❖ Physical cell ID.
  - ❖ RF parameters including pilot, maximum radio frequency power, etc..

Generally this information is provided by the backhaul channel from the Operation Support Subsystem (OSS) of the network. If this cannot be provided by the OSS, then it is possible for the femtocells to be able to detect the conditions and configure themselves accordingly. However it is always preferable for the OSS to provide the data so that the femtocells are configured according to the requirements of the network.

3. **Sensing the radio environment:** Regardless of whether femtocells configuration information is supplied from the OSS over the backhaul network, it is necessary for the femtocells to sense the radio environment. In this way femtocells can sense the signal levels of neighboring cells. The techniques used rely heavily on cognitive radio technology. There are a number of elements to the radio sensing:

- ✚ **Listen mode:** In order that the femtocells are able to sense the surrounding radio environment it must carefully listen. Accordingly it is necessary for the femtocells to have the capability to listen on its own channels as well as other channels. In listen mode, the femtocells uses similar techniques to this of standard user equipment, listening to the broadcast and control channels of the strongest base



station in the vicinity, and synchronizes with the base station. It can then distinguish the type of cell and also the estimated signal strengths and path losses. Using the information obtained from radio environment, femtocells can adjust its settings accordingly like adjusting parameters such as power level to minimize interference. Femtocells can also record its own figures for elements such as dropped calls, failed handovers and the like. In this way it is able to adjust its performance accordingly, thereby providing part of the femtocell optimization routines.

- ✚ **Message exchange:** In some instances the femtocells may broadcast information that can be received by neighboring base stations - either femtocells or even macro cells. In this way, femtocells can cooperate more effectively and improve performance as well as reducing interference.

### 3.9 Applications and Advantage of Femtocells

Femtocells have the following advantages as compared to macro cells [22]:

- ❖ **Increased system Coverage and Capacity:** A femtocells offloads a macro cell's connections, which makes the macro cell's resources available for more users. This therefore increases the capacity as well as coverage
- ❖ **Filling Coverage Holes:** Due to the limited transmission power, some portions inside the coverage area remain deficient of the optimal signal strength to make calls. Users within this area experience very poor signal quality and frequent call drops. Femtocells can be used to solve such purpose. It fills this area providing excellent signal quality such that call never drops.
- ❖ **Less cost:** A macro cell base station's (MeNB's) cost set-up is huge in comparison to the HeNB cost set-up. So, instead of setting up a new MeNB site, several HeNB can be deployed in its place.
- ❖ **Energy Efficient:** As the distance between a femtocells user (HUE) and a femtocells base station (HeNB) is very less i.e. between 5m – 20m, the battery consumption of the devices is far less than it was when the users were connected to the MeNB.



## Applications of femtocells

- ✦ Femto-Intra-zone Services: Automatic synchronization of music collection or pictures between the user's mobile phones personal computer can be done when a user returns home.
- ✦ Home Automation Services: Mobile devices can be used to control home appliances like air conditioners, light switches, washing machines.
- ✦ Access to services available today on personal computers and other home devices.
- ✦ New services enabled by the combination of telecom and multimedia capabilities from the integration of the femtocells in the digital home.
- ✦ Mobile and interactive television services, including mobility and integration with High Definition internet protocol based television services enabled via the femtocells.
- ✦ Home multimedia networking with device continuity, e.g., between personal computers etc. these applications may include machine-to-machine services within the home or business, e.g., local appliances and web cameras.



# Chapter 4: Femtocells Deployment Considerations

## 4.1 Introduction

Deploying femtocells in an LTE environment may include, realizing the full potential of LTE like coverage, capacity and all the required parameters [22], [24]. After that the deployment considerations that can be exercised are brought forward by trying to study the constraints. Those points considered are as shown below:

- ◆ Channel allocation
- ◆ Interference management
- ◆ Handover
- ◆ Access methods
- ◆ Synchronization
- ◆ Femtocells placement
- ◆ System architecture... etc

Those elements are explained along with **Figure 4-1** taking into account different assumptions as well. First the indoor propagation models can be highlighted.

## 4.2 Indoor Propagation Models

During the signal propagation between the transmitter and the receiver, the signal strength degrades due to the interaction with the surrounding environment. Different types of propagation models were proposed. Most of the proposed models are for outdoor environment and for long rang networks like macro and microcellular networks. But these models are not accurate enough to be applied in femtocells. In short range networks it is more accurate to consider more specific details in addition to the direct path between the base station and the user equipment. In this case the number of floors, walls, furniture's and etc are curbing the signal strength. Six different models of indoor propagation are going to be studied [25].

### 4.2.1 Cost231 Models



This model was proposed based on real measurements conducted in European cities at two different frequencies 900 and 1800 MHz. After that the model were scaled for other frequencies. The Cost231 one slope model where the path loss (dB) is calculated as:-

$$PL = L_0 + 10n\log(d) \text{ --- [4.1]}$$

Where  $L_0 = 20 \log\left(\frac{4\pi}{\lambda}\right)$  which is the path loss (dB) , n is the power decay index, and d is the distance between access point and UE in meter.

The second model is Cost231 linear attenuation model which is expressed as:

$$PL = L_{FSL} + \alpha d \text{ --- [4.2]}$$

Equation 4.2 indicates that there is a linear relation between the path loss and the access point-user equipment distance.  $L_{FSL} = 32.4418 + 20 \log(d) + 20 \log\left(\frac{f}{f_0}\right)$  is the free space loss (dB),  $\alpha$  is the attenuation coefficient (dB/m), and d is the distance between the access point and UE (m). Where f the frequency in GHz and d is is the distance in meters.

The previous two models are not considering the numbers of penetrated walls and floors between the transmitter and the receiver.

Therefore the Cost231 multi walls multi floors model (Cost231 MWMF) was proposed as follows:

$$PL = L_{FSL} + L_c + \sum_{i=1}^I K_{wi} L_{wi} + K_f \left[\frac{K_f+2}{K_f+1} - b\right] L_f \text{ --- [4.3]}$$

In this model, the attenuation due to walls and floors is added to the free space loss,  $L_c$  is a constant loss which determines from measurements results and it is close to zero.  $K_{wi}$  and  $K_f$  are the number traversed walls and floors respectively and  $L_f$  and  $L_{wi}$  are the losses of penetrated walls and floors respectively, and b is an empirical parameter.

#### 4.2.2 The Multi Wall Multi Floor Model (MWMF)

The path loss is expressed as:

$$L_{MWF} = L_0 + 10n\log(d) + \sum_{i=1}^I \sum_{k=1}^{K_{wi}} L_{wik} + \sum_{j=1}^J \sum_{k=1}^{K_{fj}} L_{fjk} \text{ --- [4.4]}$$

The difference between this model and the Cost231 model is the second term in the MWMF model where n is power decay index and it is determined between 1.96 and 2.03 while it is 4 in



the Cost231 one slope model and 2 in the Cost231 MWMF model. In addition, the MWMF model shows a nonlinear relation between the traversed walls or floors and the penetration loss. Where  $L_{wik}$  and  $L_{fjk}$  are the loss of  $K^{th}$  wall and floor that has been traversed (dB) and  $K_{wi}$  and  $K_{fj}$  are number of traversed walls and floors,  $I$  is the number of wall categories, and  $J$  is the number of floor categories.

#### 4.2.3 ITUR P1238-7 Model

The ITUR P1238 model was proposed for a wide range of frequency, 900 MHz to 100 GHz. Path loss is calculated as follows:

$$PL = 20 \log(f) + N \log(d) + L_f(n) - 28 \dots \dots \dots [4.5]$$

Where  $N$  is the distance power loss coefficient,  $f$  is the frequency (MHz),  $d$  is the distance in meter between the access point and UE,  $L_f$  is the floor penetration loss factor (dB), and  $n$  is the number of floors separate between the access point and UE.

#### 4.2.4 IEEE 802.11n Model

All the previous models could be defined as one slope models since only one value for  $n$  is considered. This model defined a breakpoint ( $B_p$ ) distance where the path loss before this  $B_p$  follows the free space loss LFS (slope of 2) and after the  $B_p$  the slope is increased up to 3.5.

$$PL = L_{FSL}(B_p) + 10n \log\left(\frac{d}{d_{Bp}}\right) \dots \dots \dots [4.6]$$

The  $B_p$  for the indoor scenario is 5 m.

**4.2.5 WINNER II D112 V1.2 Model:** The WINNER II channel mode was proposed for different scenarios of radio propagation such as indoor propagation, indoor to outdoor propagation, outdoor to indoor propagation, and outdoor propagation scenarios. The model was applied at 2 and 5 GHz, and then it was extended over frequency range 2-6 GHz.

The model is divided to two parts; line of sight (LOS) part is presented as:

$$PL = 18.7 \log(d) + 46.8 + 20 \log\left(\frac{f_c}{5}\right) \dots \dots \dots [4.7]$$

The second part is non line of sight (NLOS) is expressed as:

$$PL = 20 \log(d) + 46.4 + 20 \log\left(\frac{f_c}{5}\right) + 12n_w + F_L \dots \dots \dots [4.8]$$



$$\text{Where } F_L = 17 + 4(n_f - 1) \text{ --- [4.9]}$$

Where  $f_c$  the frequency in GHz is,  $d$  is the distance between the access point and the UE in meter,  $n_w$  is number of walls,  $n_f$  is number of floors.

#### 4.2.6 ITU-R M.2135-1/ 3GPP TR 36.814 Model

WIINER II model was modified and accepted by the ITU-R M.2135 and the 3GPP for indoor femtocells scenario.

The model is proposed for LOS and NLOS.

$$PL = 16.9 \log(d) + 32.8 + 20 \log(f_c) \text{ --- [4.10]}$$

$$PL = 43.3 \log(d) + 11.5 + 20 \log(f_c) \text{ --- [4.11]}$$

All previous models could be applied for three dimensional indoor environments.

### 4.3 Proposed Flow Chart

LTE femtocells network serve the high service demand of the indoor users where it is very difficult to obtain macro cells coverage. Deployment of femtocells networks embedded into LTE service coverage improves the coverage, capacity and quality of service in indoor environments [26]. As the technology move from planned operator deployment to uncoordinated user deployment (femtocells), it needs a study of the management techniques that is used for increasing the whole throughput. The following diagram represents a proposed flowchart for femtocells.

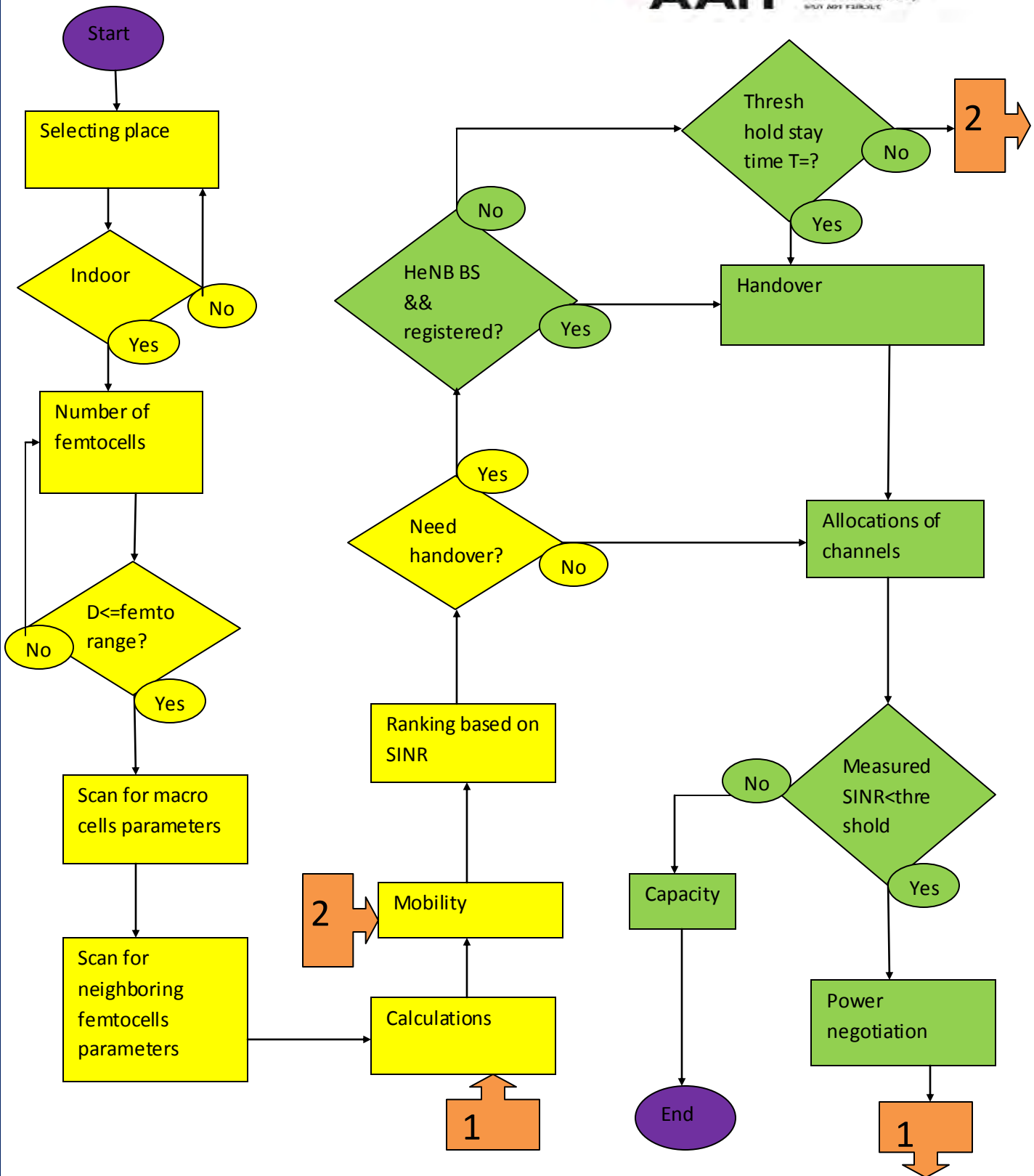

Figure 4-1: Proposed flow chart



This proposed flow chart contains major elements to be studied. Now let's explain each element of **Figure 4-1**.

### 4.3.1 Selecting a Place to Deploy

These could be categorized as home deployments or enterprise deployments. In the home deployment case, the potential scenarios could be those of dense urban deployment or spars suburban deployment. The other scenario can be a row of houses adjacent to each other having reasonable separation between each other in a sparsely populated suburban setting. Femtocells standards and economies of scale can also deliver cost-effective deployments in larger offices and in high traffic indoor and outdoor locations. Users at home may tend to use the femtocells network early in the morning before heading to work and later in the evening after returning from work. Similarly, users at work may tend to use the enterprise femtocells network during the day. On the other hand, users at home may use anything from basic voice to more diverse applications such as mobile televisions, video streaming, and peer to- peer instant messaging, online social networking web applications and etc. Depending on the application requirements, different amounts of resources may be required on different timescales. To address the above applications scenarios, femtocells are being developed for:

- ⊕ Residential
- ⊕ Enterprise use for indoor public or private deployment
- ⊕ Outdoor use for public access deployment

✚ **Residential femtocells:** They are deployed by the end user without requiring any manual configuration. The fixed broadband link may place a constraint on the maximum data rate available to the end user. Residential femtocells are typically deployed in a closed access mode supporting mobility. The number of simultaneous users supported is typically between 4 and 8 and places which are suitable for such deployments are office blocks, condo---etc.

✚ **Enterprise femtocells:** They can be deployed by the IT staffs without any additional specialist radio skills. The femtocells are connected to the mobile operator's network through the IP link already used for the data traffic of the enterprise. Femtocells for enterprise use are typically deployed in an open access (Hybrid access) mode, supporting



mobility between femtocells and the surrounding cellular network. The number of simultaneous users supported on each femtocell is typically between 8 and 32.

✚ **Outdoor femtocells:** Femtocells for outdoor use are expected to operate as public cells and are therefore likely to be deployed by the operator. They require dedicated high speed backhaul links with sufficient bandwidth to support the high throughput made possible by LTE. The number of simultaneous users supported on each femtocell is typically between 32 and 64. The main objective of these femtocells are to provide extra coverage and capacity by offloading slow moving and data intensive users from the macro.

### 4.3.2 Number of Femtocells and Their Radius

Depending on the macro RSSI, the number of femtocells needed to cover certain areas may or may not provide adequate coverage. In addition the optimum number of femtocells needed to cover a given area cannot be determined a priori as it is dependent on the location of macro cells. The number of femtocells that are required for a given coverage is decided by maximum tolerable path loss to the serving cell. Depending on the type of deployment scenarios the coverage area for a given path loss is different. Given the area of deployment scenarios and femtocell coverage area the optimum numbers of femtocells required are given as shown in equation[4.12].

$$\text{Number of femto cells} = \frac{\text{Area}}{\text{Femto coverage area}} \text{ --- [4.12]}$$

Depending on the layout of the building and building materials, femtocells coverage area may be different. Femtocells may have internal or external antenna types depending on the deployment places. As an example internal Omni-directional antenna can be used for residential houses whereas external Omni-directional antenna is used for different companies, business halls, hospital etc. The required height for transmitting antenna (ht) and maximum load (A) can be calculated as shown below. The actual radius of femtocell can vary from 10 meter to 50 meter. The maximum theoretical radius of femtocell is 100 meter.

$$Ht = \frac{Ec. \lambda. d}{Ic. 120. \pi} \text{ --- [4.13]}$$



$$A = U \cdot B \cdot \frac{T}{60} \text{ --- [4.14]}$$

Where; U=Users number, B=Call request per minute, T=average calling time, Ec=Cell voltage, λ=wavelength, Ic=cell current

### 4.3.3 Scan for Macro Cells Parameters

This is the stage where power is plugged in to femtocells. In this step femtocells can get all the required parameters of LTE base stations. It includes pilot power, maximum transmitting power rate...etc.

### 4.3.4 Scan for Neighboring Femtocells Parameters

This is the step at which all the required parameters of LTE base stations are obtained and the neighboring femtocells parameters are going to be scanned. The information can be exchanged between femtocells which are used for evaluating interference of each user of either macro or femtocells. The signaling exchange that takes places are neighbor discovery, pilot signal power which are used to determine path loss, received signal power, signal to interference plus noise ratio and finally the overall throughput on each sub channel to mention few of them.

### 4.3.5 Calculations

After all the required parameters of LTE base station and femtocells are obtained, this step involves different mathematical calculations. The mathematical equations and propagation models for LTE base stations and femtocells are included in this part as well.

#### ✓ Path loss

Path loss is the loss of power of a radio frequency signal travelling through space. It is expressed in dB. Path loss depends on:

- ◆ The distance between transmitting and receiving antennas
- ◆ The line of sight clearance between the receiving and transmitting antennas
- ◆ Antenna height

Path loss may be due to many effects, such as free-space loss, refraction, diffraction, reflection, aperture-medium coupling loss, and absorption. Path loss includes all of the loss effects associated with distance and the interaction of the propagating wave with the objects in the



environment between the antennas. The path loss model for femtocells and LTE is indicated as shown below.

⊕ **Femtocells path loss model**

The path loss of femtocells in a given condo building can be calculated by one of the indoor propagation models. MATLAB simulation for all the indoor propagation models are done. According to the results from the simulation MWMF has low path loss as compared to other models. As a result it is selected for femtocells indoor propagation analysis.

The MWMF path loss is expressed as:-

$$L_{MWF} = L_0 + 10n\log(d) + \sum_{i=1}^I \sum_{k=1}^{K_{wi}} L_{wik} + \sum_{j=1}^J \sum_{k=1}^{K_{fi}} L_{fik} \text{ --- [4.15]}$$

The explanation of the terms used in this model was done on page 36.

⊕ **LTE path loss model**

There are many models prescribed for path loss in long term evolution (LTE) environments. Among these Okumura-Hata model is the most widely used model.

The Okumura-Hata model is expressed as:-

$$L_p \text{ (dB)} = 69.55 + 26.16\log_{10}(f) + (44.9 - 6.55\log_{10}h_b)\log_{10}d - 13.82\log_{10}h_b - a(h_{mu}) \text{ --- [4.16]}$$

$$\text{Where } a(h_{mu}) = 3.2[\log_{10}(11.75h_{mu})]^2 - 4.97$$

$$a(h_{mu}) = 3.2[\log_{10}(11.75h_{mu})]^2 - 4.97 \text{ For, } (f \geq 400\text{MHz}) \text{ and}$$

$$a(h_{mu}) = [1.1\log_{10}(f) - 0.7]h_{mu} - [1.56\log_{10}(f) - 0.8] \text{ For, } (f < 400\text{MHz})$$

Where  $f$  carrier frequency (MHz),  $d$  separation between base station and user,  $h_b$  height of base station antenna,  $h_{mu}$  height of mobile unit antenna,  $a(h_{mu})$  correction factor for mobile unit antenna height. Here in this case height of base station antenna is 32m+15m=47m and user height of 1.5m from the ground.

✓ **Received power**

Once path loss for femtocells and LTE is calculated using equation [4.17] and [4.18], then calculations involving link budget analysis considers all losses and gains in the given system [27]. Many parameters related to antennas are measured in decibels; for instance, gain is often specified in decibels. The Friis Transmission Equation is used to calculate the power received



from one antenna (with gain G1), when transmitted from another antenna (with gain G2), separated by a distance R, and operating at frequency f. Noise is a common problems for any wireless communications. It is possible to remove noise from signal but impossible to make signal noise free.

The mathematical equation used to determine the received power of either femtocells or LTE is as shown below:-

$$P_{fr} = \frac{P_{ft} G_{ft} G_{fr}}{\text{path loss(HeNB)}} \text{-----[4.19]}$$

$$P_{mr} = \frac{P_{mt} G_{mt} G_{mr}}{\text{path loss(LTE)}} \text{-----[4.20]}$$

Where P<sub>t</sub> represents received power, P<sub>r</sub> ,transmitted power, G<sub>t</sub> gain of transmitting antenna, G<sub>r</sub> gain of receiving antenna. In addition f in the equation indicates femtocells parameters and m in the equation indicates long term evolutions parameters.

✓ **Signal to interference plus noise ratio (SINR)**

The fundamental interference scenarios are the same for LTE femtocells as for 3G cellular network femtocells. The followings are different interference between macro cells and femtocells as well as between femtocells.

- ✦ Macro to femto interferences(both uplink and downlink)
- ✦ Femto to macro interferences(both uplink and downlink)
- ✦ Femto to femto interferences(both uplink and downlink)

The cause of this interference might be factor like Co-channel operation versus adjacent channel operation, power difference and femtocells accesses methods.

However, it is impossible to avoid interferences but there are a lot of interference mitigation techniques that can provide acceptable and robust performance. Some of the interference mitigation techniques applicable to LTE are in line with those developed for third generation WCDMA femtocells deployments. SINR can be defined as a quality to give theoretical upper bound on channel capacity. It is defined as the power of a certain signal of interest divided by the sum of the interference power (from all other interfering signals) and the power of some background noise. The estimation of the received SINR of macro user on channel subcarrier,



when the macro user is interfered from neighboring macro cells and all the adjacent femtocells is expressed by the following equations.

$$SINR_M = P_M G_{mM} \frac{1}{N_0 f + \sum_{M'=0}^{M'=N} P_{M'} G_{M'} + \sum_{F'=0}^{F'=N} P_{F'} G_{F'}} \quad \text{--- [4.21]}$$

Where  $P_M$  transmit power of macro cell,  $P_{M'}$  transmit power of neighboring macro cell,  $G_M$  channel gain of macrocell,  $G_{M'}$  channel gain of neighboring macro cell,  $P_F$  transmit power of femtocell,  $P_{F'}$  transmit power of neighboring femtocells,  $N_0$  white noise power spectral density,  $f$  subcarrier spacing.

$$SINR_F = P_F G_{ff} \frac{1}{N_0 f + \sum_{M=0}^{M=N} P_M G_M + \sum_{F'=0}^{F'=N} P_{F'} G_{F'}} \quad \text{--- [4.22]}$$

Table 4-1 indicates the modulation technique, code rate and threshold SINR and data rate of femtocells.

Table 4-1: Threshold SINR values of femtocells

No	M	Modulation technique	Code rate	Minimum SINR(dBm)	Minimum data rate(Mbps)
1	2	Bpsk	1/2	23.83	3.125
2	2	Bpsk	3/4	25.84	4.6875
3	4	Qpsk	1/2	27.34	6.25
4	4	Qpsk	3/4	29.61	9.375
5	16	16-QAM	1/2	31.39	12.5
6	16	16-QAM	3/4	34.26	18.75
7	64	64-QAM	1/2	34.26	18.75
8	64	64-QAM	2/3	34.65	25
9	64	64-QAM	3/4	36.02	28.125
10	64	64-QAM	5/6	37.72	31.25

### 4.3.6 Mobility

This step considers the speed of user's equipment which is necessary for handover strategy to be implemented on femtocells. There are many possible target femtocells for handover as femtocells coverage area is very small. Users with a high velocity will cross the femtocells coverage area in a short time. Considering the user's quality of service high speed user may be



not necessary to execute handover. To facilitate the handoff processes the specific threshold stay time user stay in femtocells area is very important. The objective in this case is to avoid unnecessary handover request and failure. Therefore the strategy consider RSSI, the velocity of the user equipment, the signal to interference plus ratio, capacity bandwidth one femtocell can accept ,the user type and the duration UE mains the signal level above threshold level. The threshold is the minimum level required for the handover from the macro cell to femtocell [29]. The velocity of the user equipment can be categorized as follows:

- ❖ Low speed velocity between **0-15** Km/hour
- ❖ Medium speed between **15-30** Km/hour
- ❖ High speed above **30** Km/hour

Low speed velocity is recommendable for indoor scenario.

#### **4.3.7 Ranking Based on SINR**

In this step, based on the estimated SINR values, the channels are ranked in descending order. This will be used for allocating channels so that all the users can be supported.

#### **4.3.8 Handover**

Femtocell handover or femtocell handoff techniques need to ensure that seamless coverage is perceived by the user when moving. Femtocell handover is more challenging than normal macro cell cellular handover because the backhaul network is different and there is also little possibility of direct communication between the femtocells and the macro cell. Femtocells are essential that users do not see any problems with the handover process. Once the velocity of user equipment and RSSI are obtained, the handover procedures will takes place. If the speed is below 30km/hour, the handover will continue. Then femtocell with the highest available RSSI is determined based on the result from scanning and calculations that has been done. The base station which can support the bandwidth as well as having the highest SINR will be chosen. If the base station chosen is femtocell and the user equipment is registered, handover will immediately occur. The threshold time interval (T) for handover is set 0 when the registered users move from macro cell to the femtocells. If it is not registered users the threshold stay time may be 10s or 20s depending on the speed. There are a number of scenarios for femtocell handover [30]:-



- **Inbound:** This form of femtocells handover occurs when user equipment needs to transfer from a macro-cell on the standard external network to femtocells. It is quite challenging handover type because the macro cell and the femtocells will have different backhaul routes. To affect an inbound femtocells handover the same basic principles are implemented as for a macro to macro handover. However signaling for the handover needs to be undertaken via the backhaul route (S1 interface for LTE femtocells). The mobile station may have to choose between two or multiple neighboring femtocells. The node coordinates the handover by preparation, signal measurement, authentication, processing and execution. When the User Equipment is in operational it will detect local cells, including HeNB. The femtocells will have a unique ID and they will be known to the macro cell.
- **Outbound:** This is where a handover occurs from the femtocells to the macro-cell or standard cellular network. Outbound femtocells handover is somewhat similar to the standard macro-cell to macro-cell handover except that the direct interface between the base stations does not exist. In the transition process from femtocells to macro cell, the mobile station selects the appropriate **handover candidate**, **acquires authentication** and connects to the new access point. Recent handsets are configured to switch automatically to fourth generation because of the high traffic capacity but fall back to second and third generation by default when coverage is limited. Signaling must take place over the backhaul link to the core network for both the macro cell and the femtocells, although the femtocells routing will include the femtocells gateway.
- **Femtocell to femtocell:** There will be situations where handover will occur between one femtocell and another. This will be common place in offices that may have a number of femtocells to give continuous coverage within a building. For the femtocell to femtocell handover, the signaling is handled entirely within the HeNB-GW via the S1 interface for LTE. Since voice communication has some real time requirements, femtocells provides a reliable handover so that the network transmission is seamless to the user.



#### 4.3.9 Allocation of the Channels and Threshold

LTE supports many frequency bands. Femtocells can use any and all of these standardized bands. This can increase their usefulness to the operator and user. Some of the spectrum and regulatory opportunities presented by femtocells include [30]:

- **Opening up spectrum bands:** Conventional macro cell deployments exhibit very different economics at high frequencies, particularly bands above 1 GHz. Such bands are usually seen as being appropriate for delivering high capacity but not as a main means of delivering coverage. Femtocells performance, however, is almost independent of spectrum band. This enables femtocells to be used economically in higher frequencies, but also to operate efficiently in lower frequency bands.
- **Re-using existing bands:** Femtocells offer the possibility of making use of small elements of spectrum which may not be heavily used today, such as TDD sub-bands and even guard bands in some circumstances. They can also facilitate progressive migration of bands between technologies.
- **Spectrum and economic efficiencies:** The ability to deliver deep indoor coverage at much lower cost than a macro cell network enables economic efficiencies which are in the interests of the end-customer and operator.
- **Backhaul and competition:** In an LTE system the spectrum is divided into fixed sized chunks called Resource Blocks (RBs). One or more RBs can be assigned to service an application request subject to the availability of the resource and network policies. Scanning the whole spectrum is one of the techniques. If set of frequencies results in interference, then the scanning can be repeated to move to some other frequency. Another important concept is backhaul availability and bandwidth which is a critical component of femtocells deployments. The following are some considerations related to backhaul:
  - ✓ The existing classical broadband market is expected to migrate to very high data rate DSL and fiber, including:
    - ✚ Multichannel, interactive,
    - ✚ Internet television/Video
    - ✚ Home multimedia networking capabilities etc.



Channel allocation is the process of allocating Bandwidth communication channels to the base stations. There are two kinds of channel allocations that can be used in heterogeneous networks:

- ✦ **Co-channel allocation:** In this channel allocation the channels are shared among the macro users and also among the femtocells users. The channels to the femtocell and macro users are allocated based on the channel states experienced by each user for each channel. These pre-computations of channel states are done in radio resource management (RRM) and are sent to all the femtocells. The user whose channel state is more, that particular channel is allocated to the user. This method promotes frequency reuse concept but interference is high in this case. This method is used in this thesis work
- ✦ **Adjacent channel allocation:** In this channel allocation the channels are not shared among the femto and macro cells as well as among the femto and macro users. In this case interference is less but it does not promote frequency reuse concept.

Based on the ranking of the channels, the channels with more SINR value is allocated to the femtocells user. Once the channels are allocated then the users are able to communicate within the cells using the allocated channels.

#### 4.10 Power Control

In this thesis both macro cell and femtocells operate on the same frequency band. In addition to co-channel assignment if multiple units are installed in close proximity they, can cause interference on each other. Therefore these conflicting base stations may simultaneously raise transmit power in order to improve their signal quality [28]. But due to big power difference between femtocell and macro cell they have an effect on each other. When a femtocell transmits at high power, it reduces the capacity of the macro cell. As the outcome of this power problem has a direct link with interference, there are a lot of interference mitigations techniques that had been done for 2G, 3G and WCDMA. The same principle can be used for LTE as well even if the backhaul is different. Among those interference mitigation techniques, power control is one such solution. Power control is not only used to reduce interference but also minimizes power conception and achieves quality of services [29], [30]. Figure 4-2 shows an interference caused by macro cell on femtocell users for the downlink case due to power difference between macro cell and femtocell. For uplink case, interference is caused by femtocell users on macro cell and it is ignored because its effect is very low.

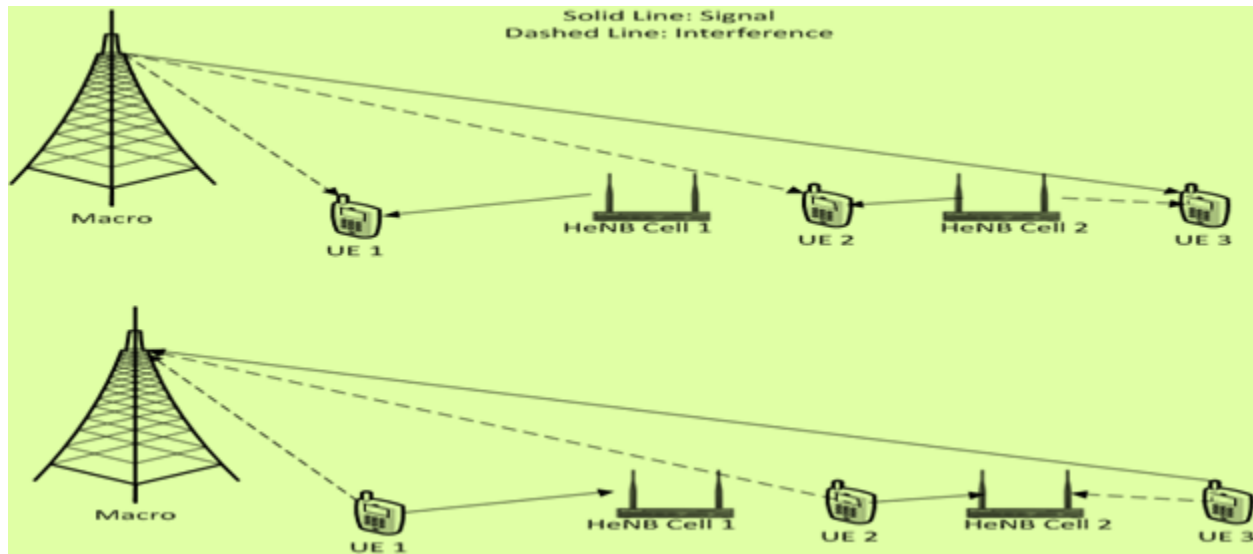

Figure 4-2: Interference cases [36]

Table 4-2: Power control of macro cell

Distance [m]	Transmit power of macro cell
$d < 100$	17dBm or 0.05
$100 \leq d < 200$	20dBm or 0.1
$200 \leq d < 300$	21.8dBm or 0.15
$300 \leq d < 400$	23dBm or 0.2
$400 \leq d < 500$	24dBm or 0.25
$500 \leq d < 600$	24.8dBm or 0.3
$600 \leq d < 700$	25.4dBm or 0.35
$700 \leq d < 800$	26dBm or 0.4
$800 \leq d < 900$	26.5dBm or 0.45
$d \geq 900$	27dBm or 0.5

Based on figure 4-3, the followings are the steps for power control:

**Step 1:** Macro cell user equipment (MUE) detects surrounding femtocells signal.

**Step 2:** Macro user equipment informs macro cell to send handover request to femtocell if the signal coming from femtocell is larger than the signal coming from macro cell.

**Step 3:** If the signal coming from macro cell is larger than the signal coming from femtocell, then femtocell increase its coverage. In order to sure that the capacity of macro cell is not reduced, the optimum distance of macro cell is taken in account as well.



**Step 4:** In this case femtocell should check its most outer placed user equipment and computes the difference between femtocell radius and the distance of most outer placed femto user equipment (FUE).

**Step 5:** The radio transmits power of femtocell is either increased or decreased according to the difference.

**Assumptions:**  $r_c$  is the coverage radius of femtocell,  is the most outer placed FUE.



Figure 4-3: Power control



# Chapter 5: Result and Discussions

## 5.1 Performance Evaluation

In this chapter femtocells impact on network performance will be evaluated. The aim is to provide a significant amount of KPIs concept which is used for performance analysis. In this thesis performance analysis is performed as a means to evaluate and compare the efficiency of LTE with and without femtocells deployment. It is based on the sample study of condo or any building having the following elements and their respective areas.

- A number of apartments
- The number of floors
- The number of walls...etc

This principle can be applicable for all types of buildings. To be able to see what is gained by adding femtocells to long term evolution, there are a set of indicators to monitor [31]. There are numerous ways to evaluate a network performance like call success, drop rate, quality...etc. Performance measures can be expressed in different ways. Accordingly the following key performance indicators are analyzed in this thesis in order to understand the improvements brought by femtocells. Those performance metrics are:

1. Propagation models
2. Received power
3. SINR
4. Channel allocation
5. Power control

### 5.1.1 Propagation Models

When moving from transmitter toward the receiver, degradation of radio signal strength will occur. This is due to the different kinds of obstacles between transmitter and receiver. The path loss for indoor users is important in femtocells deployment as these obstacles curb the signal strength. In this section around 5 indoor propagation models are analyzed and their performances are simulated using MATLAB. As shown in **Figure 5-1(a)**, the path loss for MWMF is low as compared to others considering one(1) number of wall and one(1) number of floor. Therefore the



recommended path loss model for femtocells is MWMF. In addition **Figure 5-1(b)**, indicates the same idea. It is included to show how the path loss increases as the number of walls and floors increases to three (3) and four (4) respectively. Throughout this thesis the respective loss for one wall is **5dB** and for one floor is **2dB**. The distance between femtocells and LTE base station is taken as  $\geq 500$  meter. And also the maximum theoretical femtocells radius is 100 meter and the real coverage radius is 50 meter.

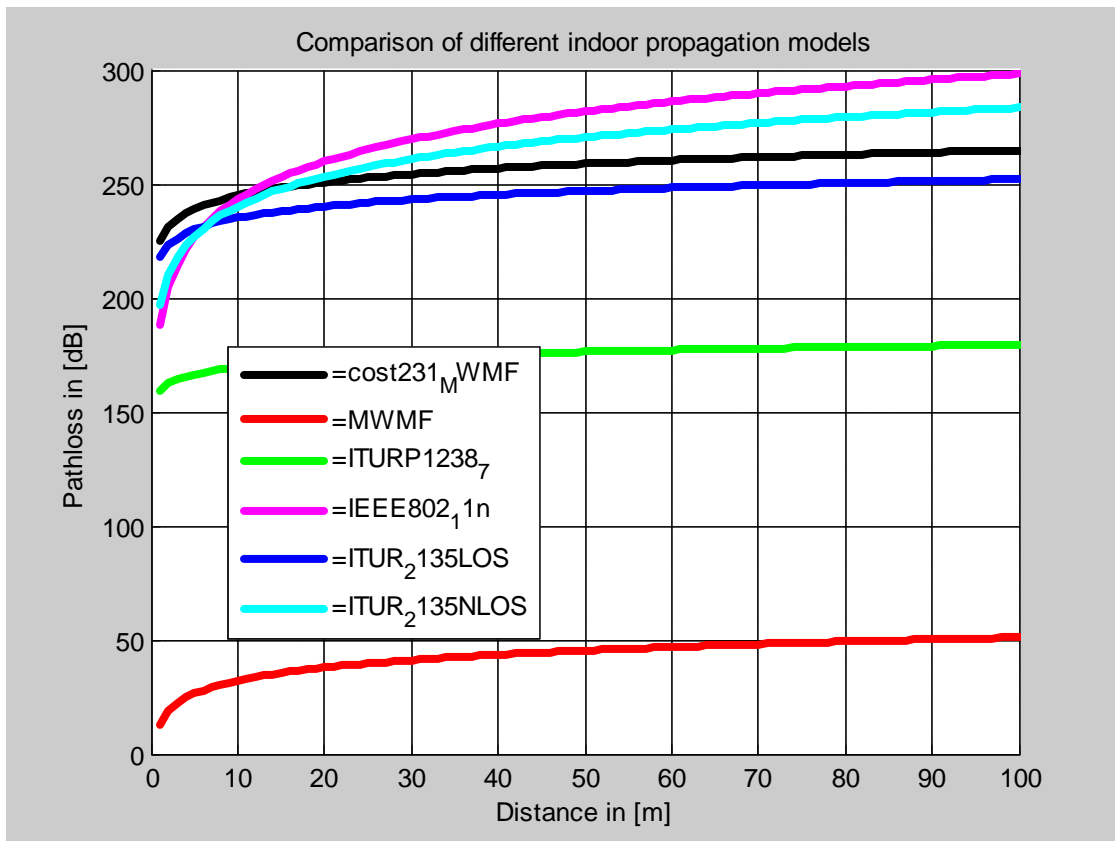

Figure 5-1(a): Indoor propagation models

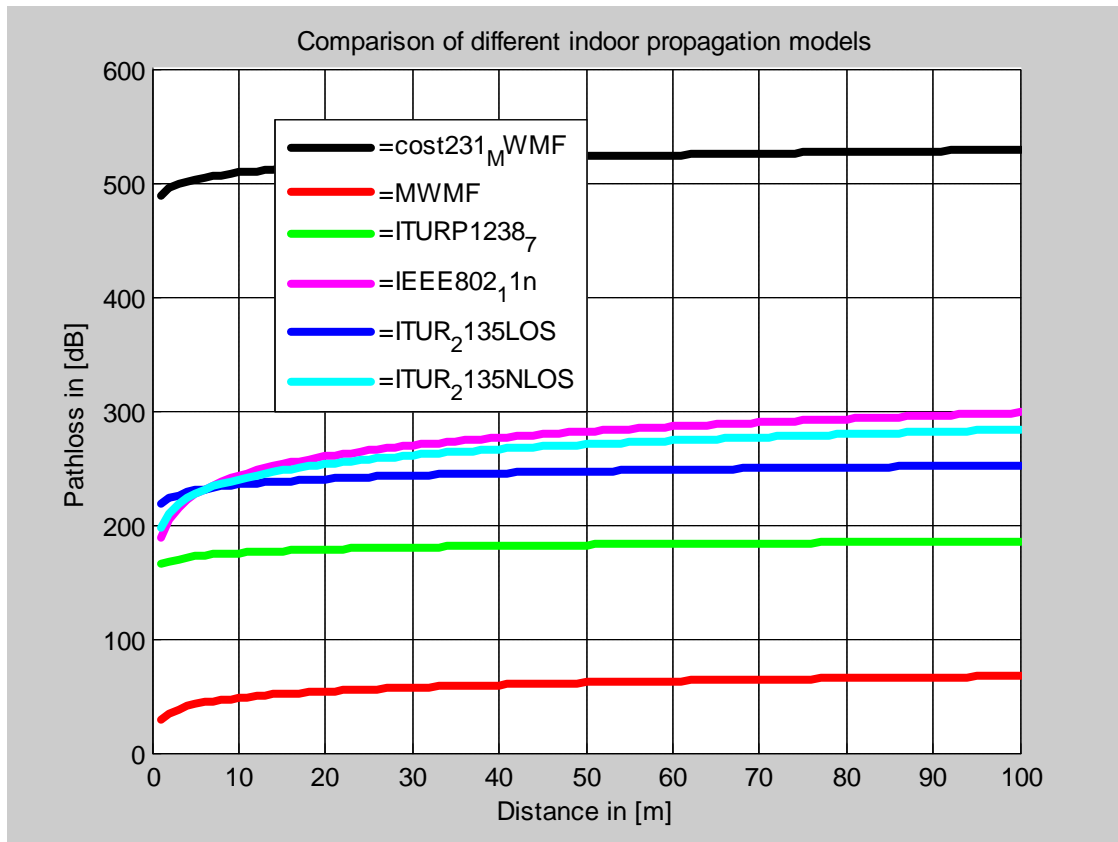

Figure 5-1 (b): Indoor propagation models

The next (3) three graphs show how the path loss is decreasing when MWMF is compared with that Okumura-Hata model of LTE for indoor users. As it is shown in these graphs the path loss of femtocell is lower than that of LTE cellular network. As the number of walls and floors are increasing, the losses are increasing as well. Assuming LTE base station is placed at certain distance from femtocell i.e. 500m. When the path loss is compared beyond femtocells place it increases as usual. But the path loss for femtocell is much lower than that of macro base station. In addition the path loss depends on LOS and NLOS of transmitter and receiver. The path loss of LOS is lower than that of NLOS as well as it is indicated in these graphs. It is clearly visible that increasing the number of walls and floors decreases the path loss. The loss corresponds to walls and floors are different. This depends on materials that are used for such building like concrete, wood, steel, bricks and etc. It also depends on individual material properties like permeability. Accordingly the loss of one wall and one floor is **5dB** and **2dB** respectively as it is previously mentioned. **Figure 5-1(c)** shows path loss comparison of macro cell and femtocell for one wall



(1) and one floor (1). **Figure 5-1(d)** and **Figure 5-1(e)** do the same but for one(1) wall, five floors(5) and five walls(5), one floor(1) respectively.

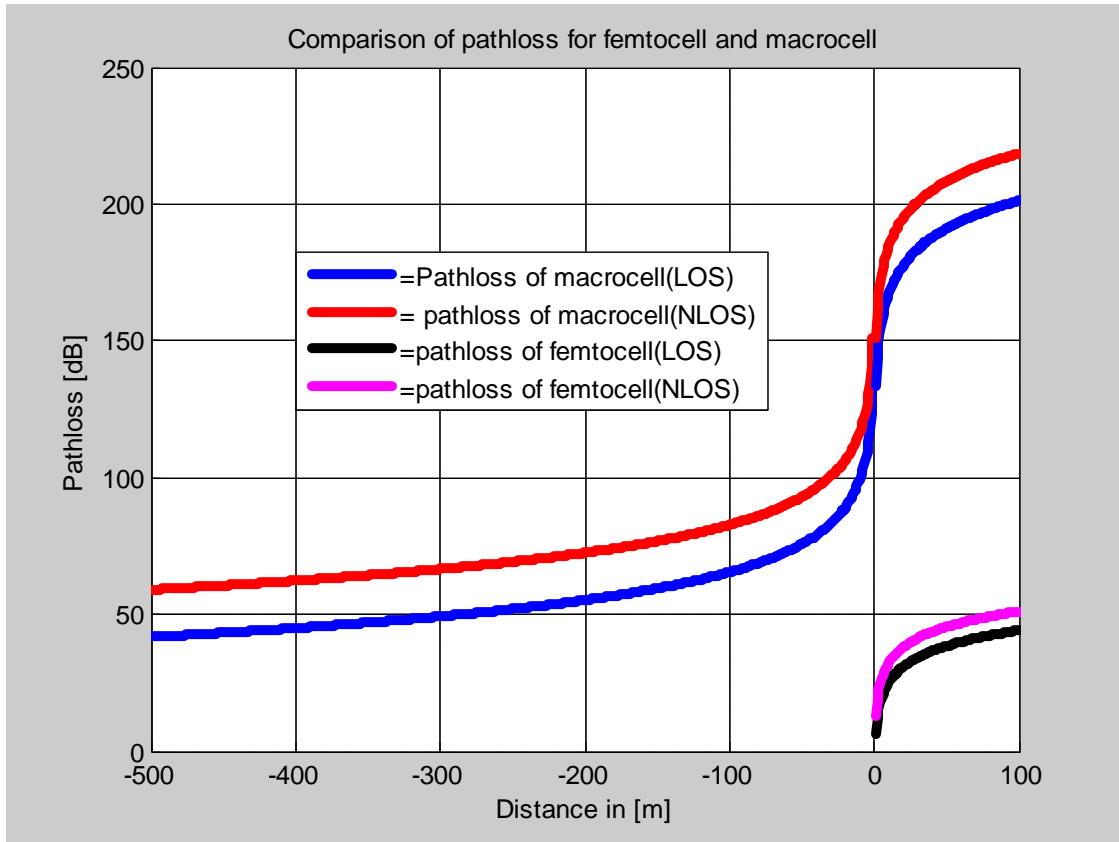

Figure 5-1(c): Path loss of femtocell and macro cell

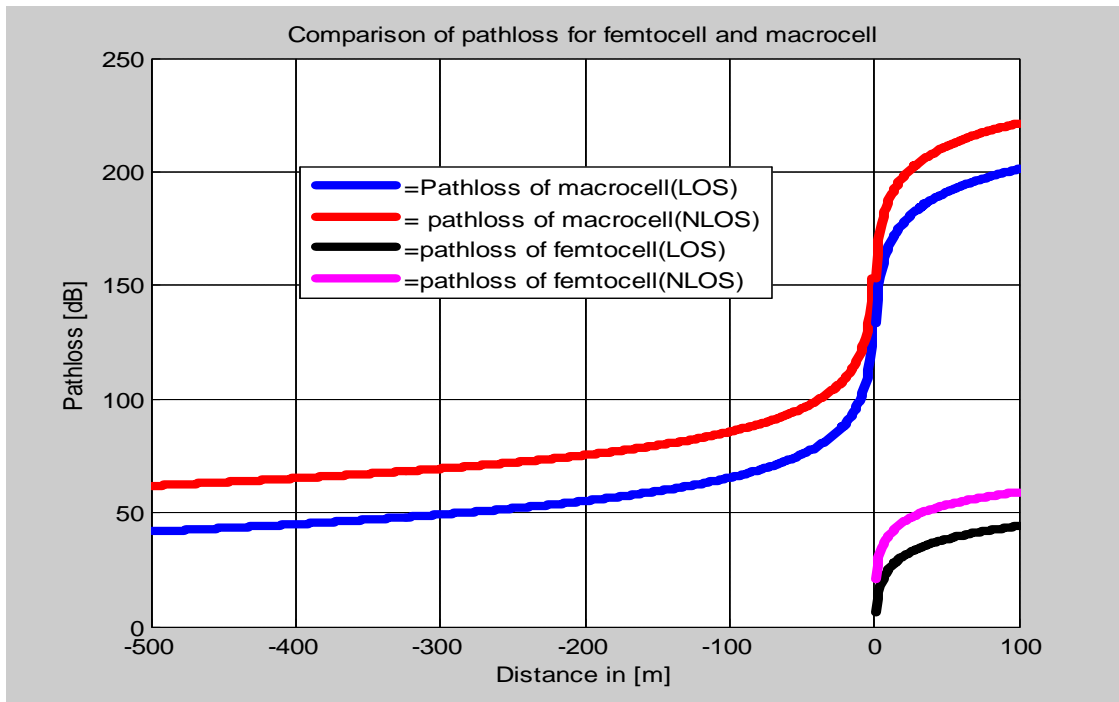

Figure 5-1 (d): Path loss of femtocell and macro cell

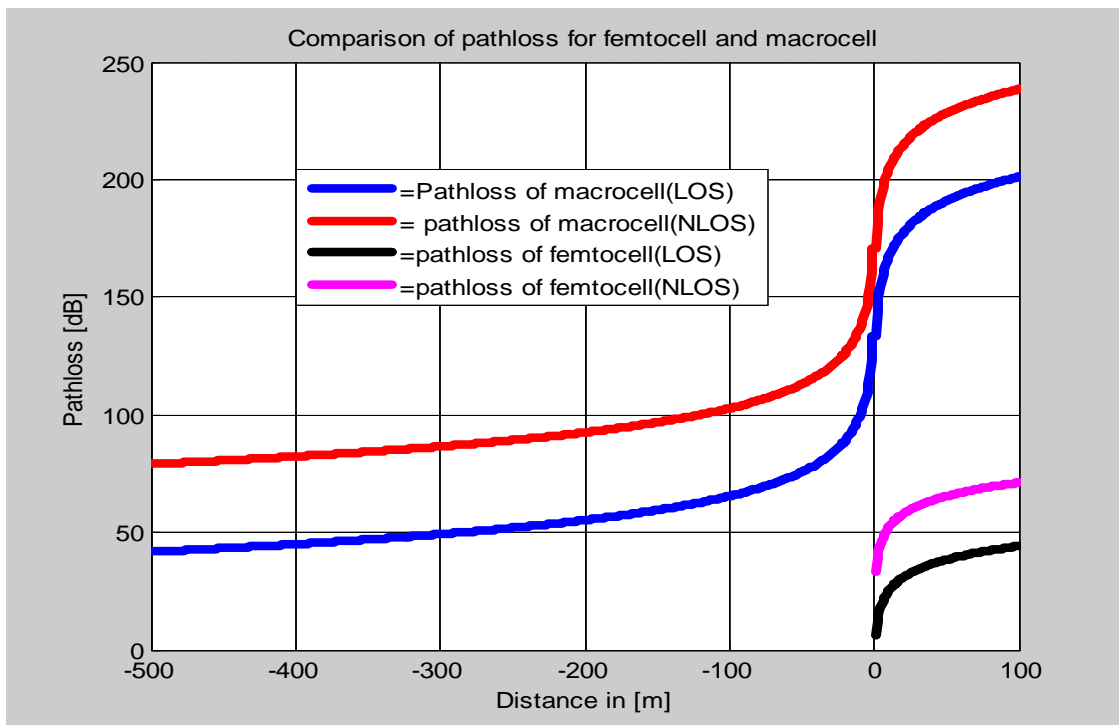

Figure 5-1 (e): Path loss of femtocell and macro cell



### 5.1.2 Received power

Based on the path loss of LTE and femtocell the corresponding received power for NLOS of femtocell and NLOS of LTE are indicated on the following graphs. As the path loss increase, the received power decreases. This is due to multiple reflection of signal with structure of the building. It depends on different antenna gains, frequency of operation, transmit power...etc. It is indicated on the graph that femtocell users have good received signal level in the part of building near around the femtocells. The results of simulations show that it is desirable to deploy femtocells in dead-zone areas under LTE. **Figure 5-2(a)** shows the received power of macro cell and femtocell for one wall (1) and one floor (1). **Figure 5-2(b)** and **Figure 5-2(c)** clearly indicates received power for three walls (3), three floors (3) and five walls (5), five floors (5) respectively. Just like path loss we can see the how the gap is large as the number of walls and floors are increasing for LOS and NLOS.

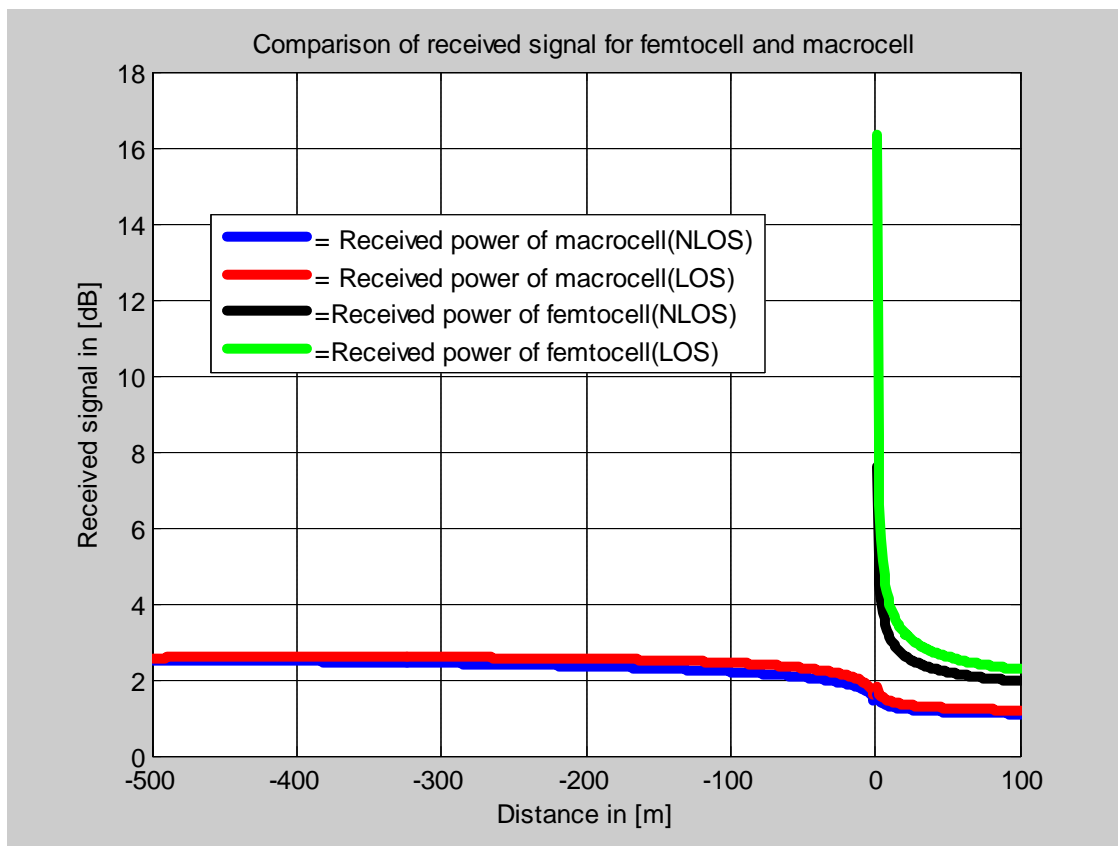

Figure 5-2(a): Received power of macro cell and femtocell

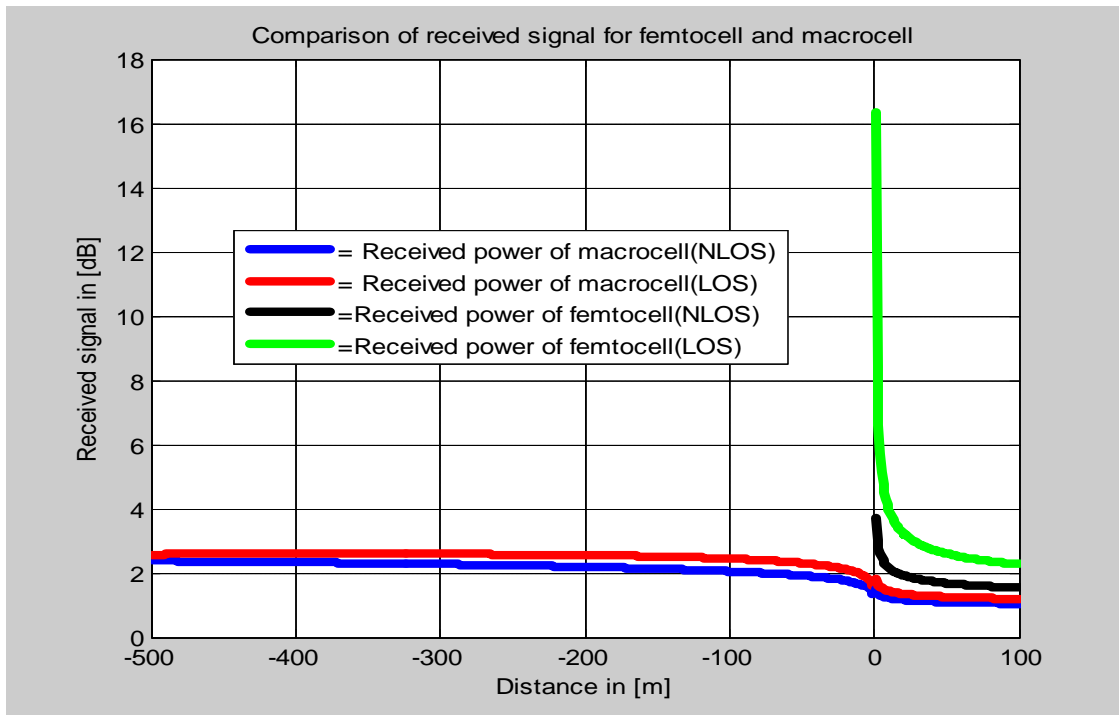

Figure 5-2 (b): Received power of macro cell and femtocell

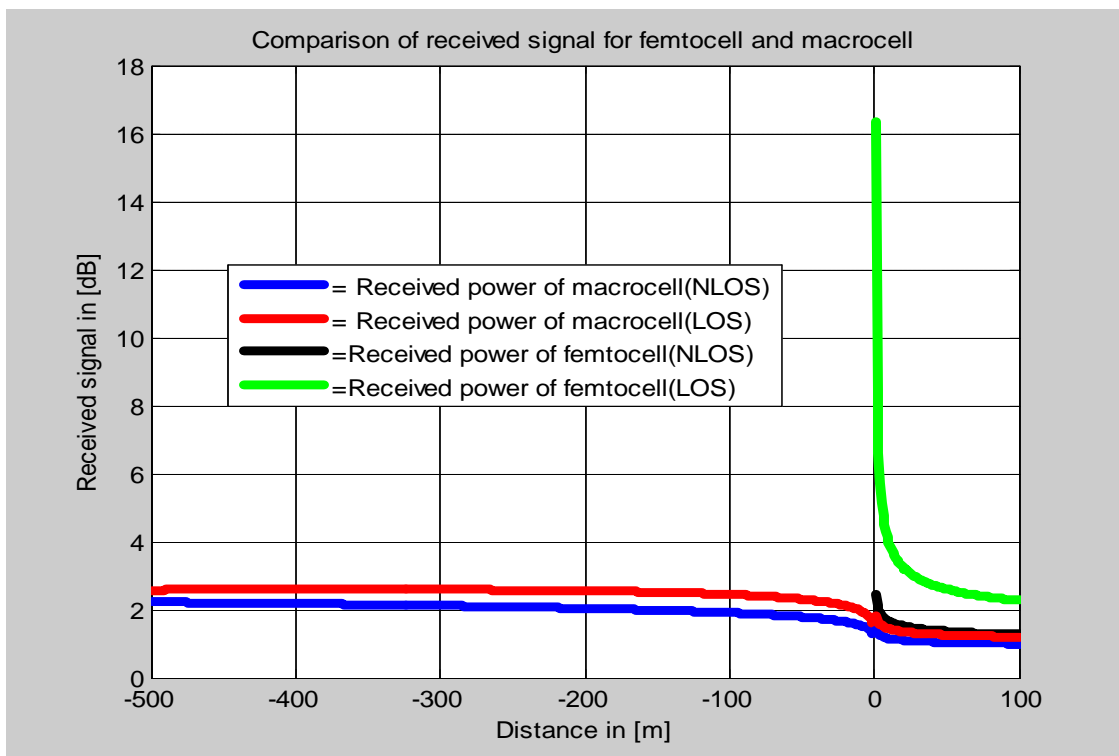

Figure 5-2(c): Received power of macro cell and femto cell



### 5.1.3 Signal to interference plus noise ratio

In this section the signal to interference plus noise ratio of LTE and femtocell is explained based on the results. The SINR of all the users are compared to the threshold value of particular base station. As a result if the SINR is less than the threshold values it raises a situation of conflict that might happen due to interference from neighboring cells. If the measured SINR is not less than the threshold value, then the overall capacity of wireless link can be obtained. Accordingly the values of SINR are shown on the graph after applying path loss models both for femtocells and LTE. As it can be seen the closer to the base station, the higher SINR and also as we move away from the base station interferences from neighboring cells increases and thus SINR value decreases. It was performed by dividing a useful signal by the interference combined with noise. In this analysis the graphs show SINR of macro cell and femtocell that are:

- Case 1: LTE interfered by neighboring LTE and femtocells
- Case 2: femtocell interfered by LTE and femtocells
- Case 3: LTE interfered by LTE only and femtocell interfered by femtocells only

**Figure 5-3(a)** shows SINR of LTE interfered by both neighboring LTE and femtocells. As it is shown on the graph SINR of LTE is plotted for the case of three(3) number of walls, three(3) number of floors, two(2) interfering LTE cells and four(4) interfering femtocells.

**Figure 5-3(b)** shows the SINR of femtocells for the case of three(3) number of walls, three(3) number of floors and interfered by four(4) LTE cells and two(2) femtocells.

And finally **Figure 5-3(c)** shows both SINR of LTE and femtocell on the same graph for the case of LTE cell interfered by LTE only and femtocell interfered by femtocells. In this part three (3) numbers of walls, three (3) numbers of floors and interfered by four (4) LTE cells and four (4) femtocells. It is impossible to perform manipulation on MAT LAB for the matrixes having different dimensions. That is why the same types of base station are considered in case 3.

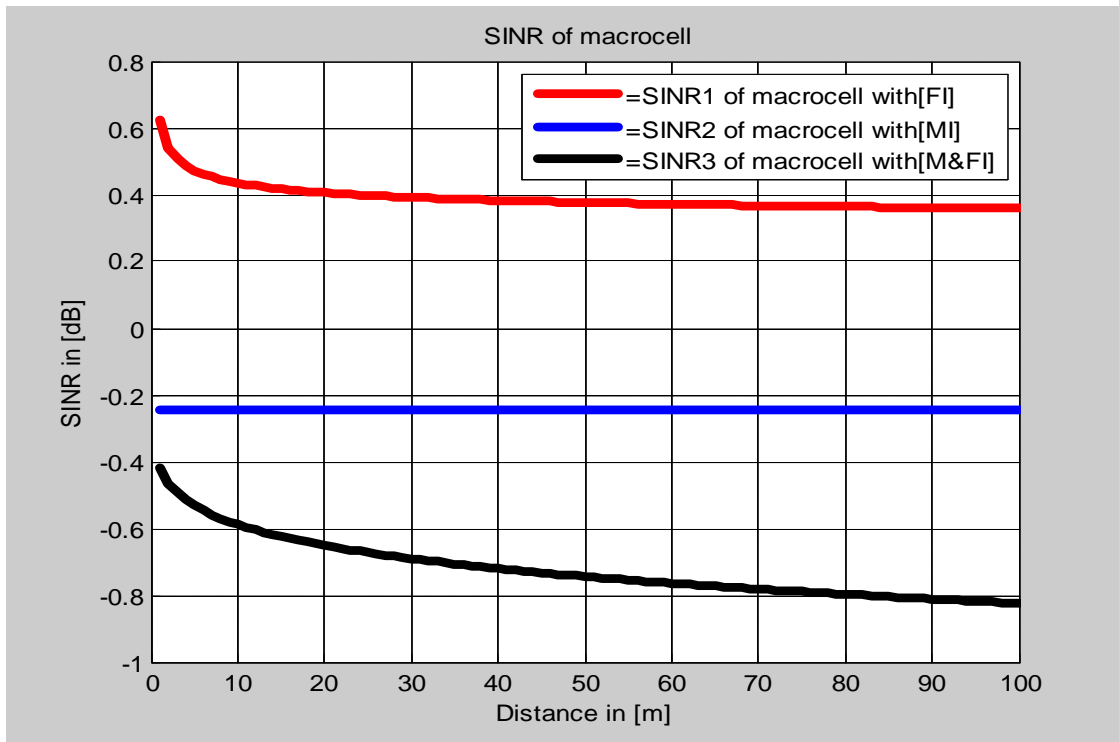

Figure 5-3(a): SINR of macro cell

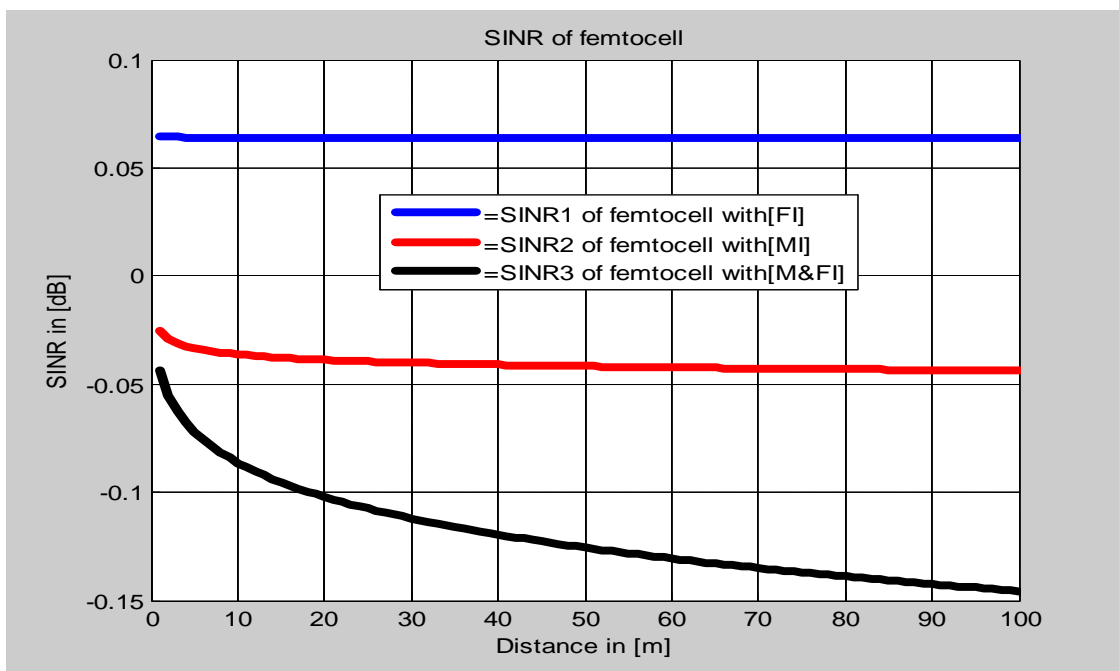

Figure 5-3 (b): SINR of femtocell

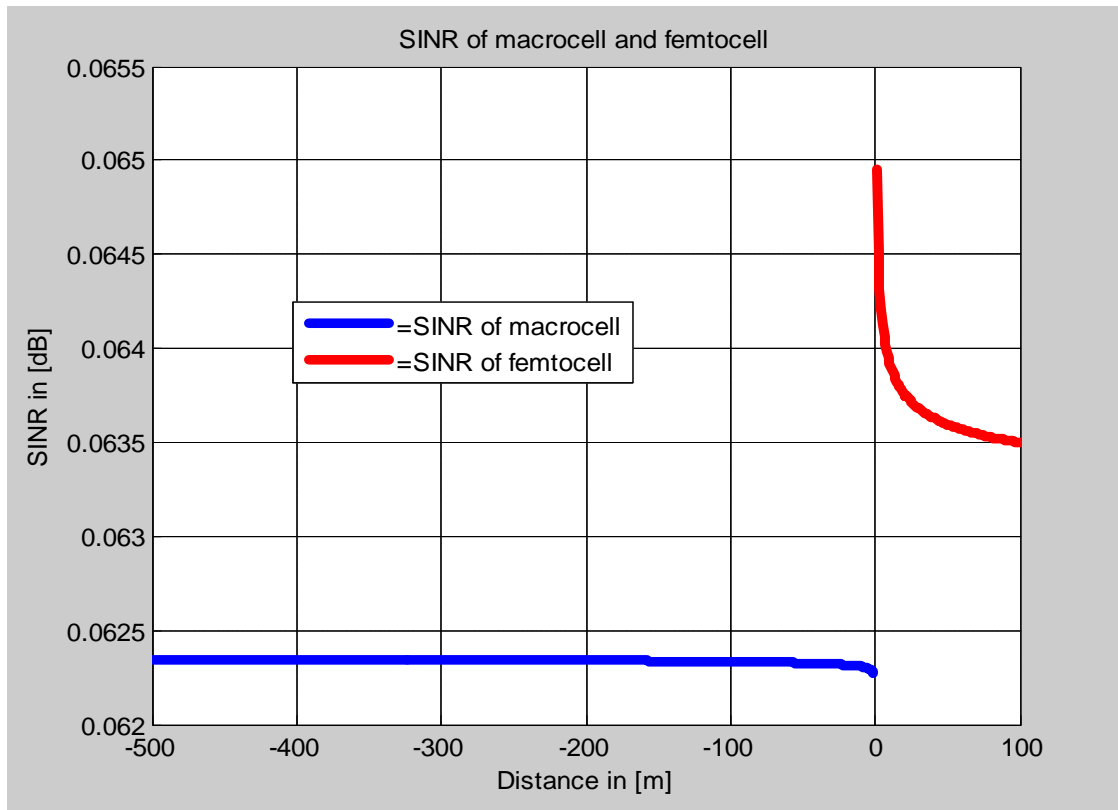

Figure 5-3(c): SINR of macro cell and femtocell

#### 5.1.4 Channel allocation

This section considers the total area of a given building, the coverage area of femtocell and then the numbers of subscribers are calculated. The random channel assignment and FFT-1024 subcarrier arrangement is used in this analysis. It will allocate sub carriers to all the users in the given femtocell coverage area. And also spectrum will be shared among 720 subcarrier based on the number of users present in the femtocell. For this study 6 numbers of users per one femtocell is used.

---

ADDIS ABABA UNIVERSITY

ADDIS ABABA INSTITUTE OF TECHNOLOGY

DEPARTMENT OF ELECTRICAL AND COMPUTER ENGINEERING



## DEPLOYMENT OF LTE FEMTOCELLS IN DEAD ZONE AREAS FOR THE CASE OF ADDIS ABABA

---

Select an option:

- 1 – Path loss
  - 2 - Received power
  - 3 - Signal to interference plus noise ratio (SINR)
  - 4 - Channel allocation
  - 5 - Data rate
  - 6 - Power control
- 

Select from the above option

4

In order to see random allocation of spectrum follow the following steps

---

Enter the total area

42000

Enter femtocell coverage area

7000

Columns 1 through 7

241    976    819    585    993    902    548

Columns 8 through 14

794    923    857    656    716    1003    180

Columns 15 through 20



599      651      403      84      674      689

### 5.1.5 Data rate

Once path loss, SINR is plotted for LTE and femtocell, the capacity can be calculated taking into account noise generated, channel type and modulation schemes. As a result the capacity is calculated by measuring the number of received bits using one sample modulation techniques schemes. The channel type that used in this study is uncorrelated Rayleigh fading channel because it considers multi-path situations such as reflection, refraction and scattering. 16 QAM modulation scheme is used as a sample for analysis. It is clearly visible that the capacity of femtocell interfered by femtocells is greater than that of interfered by macro cells and femtocells. In addition as the number of walls, floors, interfering macro cells and femtocells increases, then the capacity decreases as well. But it depends on random noise generated at different times. The result is indicated as shown below for three (3) trials each having its own number of walls, floors, interfering macro cells, interfering femtocells.

#### Trial one

=====

ADDIS ABABA UNIVERSITY  
ADDIS ABABA INSTITUTE OF TECHNOLOGY  
DEPARTMENT OF ELECTRICAL AND COMPUTER ENGINEERING  
DEPLOYMENT OF LTE FEMTOCELLS IN DEAD ZONE AREAS FOR THE CASE OF  
ADDIS ABABA

=====

Select an option:

- 1 – Path loss
- 2 - Received power
- 3 - Signal to interference plus noise ratio (SINR)
- 4 - Channel allocation
- 5 - Data rate
- 6 - Power control

=====



Select from the above option

5

In order to calculate the capacity of femtocell and macro cell using 16QAM modulation techniques follow the following steps

=====

Enter the number of walls

1

Enter the number of floors

1

Enter the number of interfering macro cells

1

Enter the number of interfering femtocells

1

Capacity of femtocell interfered by femtocells=2.5663

Capacity of femtocell interfered by macro and femtocells=2.5381

**Trial two**

=====

ADDIS ABABA UNIVERSITY

ADDIS ABABA INSTITUTE OF TECHNOLOGY

DEPARTMENT OF ELECTRICAL AND COMPUTER ENGINEERING

DEPLOYMENT OF LTE FEMTOCELLS IN DEAD ZONE AREAS FOR THE CASE OF

ADDIS ABABA

=====

Select an option:

1 – Path loss

2 - Received power

3 - Signal to interference plus noise ratio (SINR)

4 - Channel allocation

5 - Data rate



6 - Power control

---

Select from the above option

5

In order to calculate the capacity of femtocell and macro cell using 16QAM modulation techniques follow the following steps

---

Enter the number of walls

2

Enter the number of floors

3

Enter the number of interfering macro cells

3

Enter the number of interfering femtocells

3

Capacity of femtocell interfered by femtocells=2.5343

Capacity of femtocell interfered by macro and femtocells=2.5395

**Trial three**

---

ADDIS ABABA UNIVERSITY

ADDIS ABABA INSTITUTE OF TECHNOLOGY

DEPARTMENT OF ELECTRICAL AND COMPUTER ENGINEERING

DEPLOYMENT OF LTE FEMTOCELLS IN DEAD ZONE AREAS FOR THE CASE OF

ADDIS ABABA

---

Select an option:

1 – Path loss

2 - Received power

3 - Signal to interference plus noise ratio (SINR)



4 - Channel allocation

5 - Data rate

6 - Power control

---

Select from the above option

5

In order to calculate the capacity of femtocell and macro cell using 16 QAM modulation techniques follow the following steps

---

Enter the number of walls

5

Enter the number of floors

5

Enter the number of interfering macro cells

5

Enter the number of interfering femtocells

5

Capacity of femtocell interfered by femtocells=2.5532

Capacity of femtocell interfered by macro and femtocells=2.4957

### 5.1.6 Power Control

This is the final part of analysis for this study which is used to control the power of femtocells so that the overall throughput is optimum. In order to avoid femtocells performance degradation due to macro cell user uplink power, power control is the most important concept. It will take into consideration the distance of macro cell user from base stations and allocate appropriate uplink power to the user. These optimum distances for LTE are indicated in table 4-2 under power control section. Two important cases are considered:-

#### Case 1: No handover required

If the signal coming from LTE is larger than the signal coming from femtocell for macro user, then no handover is required. Therefore femtocell will increase its power iteratively to the



maximum of its coverage area until handover occurs. The sample result is indicated as shown below.

---

ADDIS ABABA INSTITUTE OF TECHNOLOGY  
DEPARTMENT OF ELECTRICAL AND COMPUTER ENGINEERING  
DEPLOYMENT OF LTE FEMTOCELLS IN DEAD ZONE AREAS FOR THE CASE OF  
ADDIS ABABA

---

Select an option:

- 1 – Path loss
  - 2 - Received power
  - 3 - Signal to interference plus noise ratio (SINR)
  - 4 - Channel allocation
  - 5 - Data rate
  - 6 - Power control
- 

Select from the above option

6

In order to analyze the power control of macro cell and femtocell follow the following steps

---

Enter the radius of femtocell

40

Enter the maximum theoretical radius of femto cell

80

Enter the radius of the outer most placed user equipment of femtocell

28

Enter handover request for no handover HO=0

0



Enter the distance of macro user equipment

500

The recommended macro power for the given distance is=

0.3000

The radius of femtocell after power adjustment is=

41

**Case 2: Handover required**

If the signal coming from femtocell is larger than the signal coming from LTE for macro user, it sends hand-over request message to the LTE and then to the femtocells to perform handover procedure. If this happen, femtocell will reduce its power iteratively until the signal coming from LTE is larger. Here is the sample result for this case.

=====

ADDIS ABABA UNIVERSITY  
ADDIS ABABA INSTITUTE OF TECHNOLOGY  
DEPARTMENT OF ELECTRICAL AND COMPUTER ENGINEERING  
DEPLOYMENT OF LTE FEMTOCELLS IN DEAD ZONE AREAS FOR THE CASE OF  
ADDIS ABABA

=====

Select an option:

- 1 – Path loss
- 2 - Received power
- 3 - Signal to interference plus noise ratio (SINR)
- 4 - Channel allocation
- 5 - Data rate
- 6 - Power control

=====

Select from the above option

6



In order to analyze the power control of macro cell and femtocell follow the following steps

Enter the radius of femtocell

40

Enter the maximum theoretical radius of femto cell

80

Enter the radius of the outer most placed user equipment of femtocell

28

Enter handover request for no handover HO=0

1

Enter the distance of macro user equipment

500

The recommended macro power for the given distance is=

0.3000

The radius of femtocell after power adjustment is=

28

In general some common MATLAB simulation parameters are included in the table 5-1.

Table 5-1: MATLAB simulation parameters

PARAMETERS	VALUES
LTE base station transmit power	46dB
LTE uplink frequency	1710-1785
LTE downlink frequency	1851.5-1871.5
LTE antenna type	2X2
Antenna gain of LTE BS	15dBm
Distance between LTE cells	> 500m
Minimum distance between MS and LTE	35m
Subcarrier spacing	15KHz
Femtocell transmit power	20dBm



Femtocell antenna type	Omni-directional
Antenna gain of femtocell	2dBm
Minimum distance between LTE BS and femtocell	500m
Minimum distance between MS and femtocell	20cm
Channel type	Uncorrelated relay fading channel
Frequency	It uses co-channel assignment with LTE
White noise spectral density	-174dBm/Hz
Placement of femtocell	Random
Building types	All
Noise	Assuming random generation
Coverage radius	Up to 50m
Recommended loss of 1 wall	5dB
Recommended loss of 1 floor	2dB
Number of users per femtocell	6



# Chapter 6: Conclusion and Recommendations

## 6.1 Conclusion

Ethiopia is implementing development and transformation strategy to be middle-income country in the next twenty five years. Ethio telecom is one part of this strategy which is used as an input for the successful accomplishment of this mission. To mention one, LTE is the recent technology currently under deployment in Addis Ababa. LTE is the new technology which is used for increasing the capacity, coverage and enhancing the overall performance of the network. But the entire city of Addis Ababa is under construction. As a result LTE alone cannot support the ever growing demand of the bandwidth hungry applications for the indoor users in Addis Ababa. Without any assistant it loses some of its actual capacity. The full advantage of LTE can be seen with support of femtocells.

Femtocells provide an attractive solution for meeting capacity requirements of the network in different buildings including residential houses. They have the potential to provide high quality network access as it is investigated in this thesis. This thesis identified the benefits of femtocells, technical challenges, propagation modes and their performance metrics as well. Accordingly MWMF indoor propagation model is chosen for femtocells. In addition the performance analysis of LTE with and without femtocells deployment is included. The key performance indicators considered are: - Received power, SINR, power control and capacity. Generally it was investigated that the number of walls, the number of floors and furniture attenuated the received signal strength of LTE. This is clearly shown in the simulation. Simulation results show femtocells restores the LTE capacity in indoors areas. From business perspective, femtocells will generate revenue growth if deployed in business places. Cost wise it is much cheaper than macro base stations.



## 6.2 Recommendations

Increasing demand for mobile data traffic is bringing new challenges on cellular networks deployment. So, in order to increase the average user capacity and coverage, the use of LTE femtocells have come up as a promising solution. In the future LTE will unable to support the high traffic demand. Therefore LTE-A or new technology may come. Surprisingly, femtocells should coexist/compatible with the former deployment and future new deployment as well. Different business activities are taking place in big buildings at Addis Ababa. And also a number of big companies were opened and this will continue in the future as well. As result this study recommends Ethio telecom:-

- ◆ Use femtocells under LTE coverage where there is a limited network capacity.
- ◆ Carry out different researches on femtocells as they are very important to increase the data rate.
- ◆ Understand the problems of indoor users for different buildings in detail.
- ◆ Know possible ways to perform different optimization activities within limited resource for femtocells.
- ◆ Know how femtocells will reduce unnecessary number of LTE base stations.



## References

---

- [1] L-F Pau, Prof. Mobile business, 2011, Summary Introduction to Wireless LTE\*4G Architecture and Key Business Implications, Page 1-78.
- [2] IEEE Communications Society DSP –J Erfanian, 2013, Evolution of Wireless Communications, Page 1-25
- [3] 4G America’s Member Company Contribution, August 2013, Mobile Broad Band Explosion: The 3GPP Wireless Evolution, Page 1-162.
- [4] Robert Nibarger and Mallorie Teubner, August 2012, an Introduction to Long Term Evolution, Page 1-8.
- [5] Ian F. Akyildiz , David M. Gutierrez-Estevez, Elias Chavarria Reyes, United States 2010, the Evolution to 4G Cellular Systems, Page 1-217.
- [6] Dahl man, Parkvall, Skold and Beming, UK 2008, 3G Evolution: HSPA and LTE for Mobile Broadband, Academic Press, Second edition.
- [7] ITU/BDT Arab Regional Workshop, Tunisia 2010, 4G Wireless Systems, Page 1-82.
- [8] Ian Poole, LTE Frequency Bands and Spectrum allocations, [posted on 5/4/2013], [accessed on 22/9/2014], <http://www.radio-electronics.com/info/cellular/telecomms/lte-longterm-evolution/lte-Frequency-Spectrum.php>
- [9] 3GPP, 2007-2012, GPRS Enhancements for E-UTRAN Access, volume 8.0
- [10] Apis Technical Training AB, 2007, LTE/SAE-Introduction, page 1-84.
- [11] Kévin Redon, 24th March 2012 Berlin, Introduction to Femtocells, Page 1-20.
- [12] Kanak Raj Chaudhary, Deepest Rawat, Eisha Madwal, 2013, Interference Aware & SINR Estimation in Femtocell Networks, p- ISSN: 2278-8727 Volume 10, Page 1-6.
- [13] Fourat Haider, Mehrdad Dianati, Rahim Tafazolli Center for Communication Systems Research University of Surrey UK, A Simulation Based Study of Mobile Femtocell Assisted LTE Networks, Page 1-6.
- [14] Seema M Hanchate, Sulakshana Borsune, Shravani Shah pure, Nov-Dec 2012, 3GPP LTE FEMTOCELL – PROS & CONS, Volume-2, Issue-6, Page 1-7.



- [15] KhaledElleithy and VarunRao, March 2011, Femto Cells: Current Status and Future Directions”, International Journal of Next-Generation Networks (IJNGN) Vol.3, No.1.
- [16] Signals Research, LLC, February 2010, Femtocell Business Case. Femto Forum White Paper.
- [17] J. Andrews et al, Feb 2010, A Tractable Framework for Coverage and Outage in Heterogeneous Cellular Networks, page 1-113.
- [18] The Femto Forum, May 2010, The Best That LTE Can Be – Why LTE Needs Femtocells. Femto Forum White Paper, page1-23.
- [19] Vikram Chandrasekhar and Jeffrey G. Andrews, the University of Texas at Austin Alan Gatherer, June 28, 2008, survey, Page1-23.
- [20] Jyri Hämäläinen, Comnet/Aalto University, Oulu, 29.7.2011, Femtocells: Technology and Developments, Page 1-73.
- [21] YuanyeWang, K.Pedersen, Beatriz Soret, and Frank Frederickson, September 2012, eICIC Functionality and Performance for LTE HetNet Co-Channel Deployments.
- [22] Kanak Raj Chaudhary, August, 2013 IJECS Volume 2 Issue 8, Page 2476-2480
- [23]Holger Claussen, Lester T. W. Ho, and Louis G. Samuel, 2008,an Overview of the Femtocell Concept, Page1-25.
- [24] Telecommunications Research Laboratory Toshiba Research Europe Ltd, January 2010 Radio Resource Management Considerations for LTE Femto Cells, volume 40, Page 1-5.
- [25] A Zyoud1, J Chebil, M H Habaebi, Md R Islam, and A K Lwas, 2013, Investigation of Three Dimensional Empirical Indoor Path Loss Models for Femtocell Networks, Page1-11.
- [26]Siemens Networks Finland, 2011, white paper: Improving 4G Coverage and Capacity Indoors and at Hotspots with LTE Femtocells, Page 1-8.
- [27] Mike Willis, Link Budgets,[posted on 5/5/2007], [accessed on 5/12/2013],<http://www.mike-willis.com/Tutorial/PF13.htm>
- [28] Christos Bouras Computer Technology Institute& Press Diaphanous University of Patras, October 21-22,2012,A Simulation Framework for LTE Systems with Femtocell Overlays,Page1-6.



- [29] Adrian Ulvan, Robert Bestak Department of Telecommunication Engineering Czech Technical University in Prague, Czech Republic,2010, Handover Scenario and Procedure in LTE-based Femtocell Networks, Page 4-6.
- [30] Sawsan A. Saad, Mohamed Ismail, and Rosdiadee Nor din National University of Malaysia, December 2013, A Survey on Power Control Techniques in Femtocell Networks, Journal of Communications Vol. 8, No. 12, Page 1-10.
- [31] Holger Claussen; Lester T. W. Ho; Louis G. Samuel, an Overview of the Femtocell Concept, Bell Labs Technical Journal, 2008, Volume 13 Issue: 1, Pages 221-245
- [32] Mikko Lauri Juhani Järvinen, 03 June 2009, Deployment of Femtocells in 3rd Generation Networks, Page 1-89.
- [33]DinoFlore, 3GPP RAN chairman, Femtocells Basic Concepts,[posted on 9/8/2012], [accessed on 3/16/2014],<http://www.3gpp.org/>.
- [34] Wikipedia the free Encyclopedia, LTE Femtocells,[posted on 1/2/2013], [accessed on 3/16/2014],<http://www.en.wikipedia.org/Wiki/femtocell>.
- [35] Keith Maccinson, Wise harbor, Heterogeneous Networks in LTE, [posted on 3/6/2013], [accessedon19/5/2014],<http://www.radio-electronics.com/info/cellulartelecomms/heterogeneous-networks-hetnet/basics-tutorial.php>.
- [36] Long Gao Wireless Systems Research Lab, Hitachi America, Ltd. Santa Clara, USA, IEEE WCNC 2013, Heterogeneous Networks – Theory and Standardization in LTE, Page 1-113.



# Appendix

## I. Indoor path loss models

```
function []=PATHLOSS_MODELS()
%|=====A program developed by Dejene H. =====|
disp ('=====')
disp ('ADDIS ABABA UNIVERSITY')
disp ('ADDIS ABABA INSTITUTE OF TECHNOLOGY')
disp ('DEPARTMENT OF ELECTRICAL AND COMPUTER ENGINEERING')
disp ('DEPLOYMENT OF LTE FEMTOCELLS IN DEAD ZONE AREAS FOR THE CASE
OF ADDIS ABABA')
disp ('=====')
disp ('Select an option:')
disp (' 1 – path loss')
disp ('=====')
disp ('Press 1 to continue.....')
itype = input("");
switch itype,
case 1
%|=====COST231_MWMMF MODEL=====|
no_walls=input ('Enter the number of walls\n');
no_floors=input ('Enter the number of floors\n');
loss_floors=2;
loss_walls=5;
d= 0:1:100;
f=1861.5*10^6;
Freespace_loss=32.4418+20*log10 (d) +20*log10 (f);
for W=1:no_walls, X=+ (W*loss_walls);end
g= ((no_floors+2/no_floors+1)-2);
```



```
Y=no_floors.^g*loss_floors;
cost231_MWMF=Freespace_loss+X+Y;
grid on
hold on
plot (d, cost231_MWMF,'k','linewidth',3,'markersize',8)
%|=====MULTI WALL MULTI FLOORS MODEL=====|
n=1.9;
pi=3.14; c=3*10^8;
lamda=(1861.5*10^6)/c;
Lo=20*log10 (4*pi/lamda);
for i=1:10, for W=1:no_walls,A+=(loss_walls*W);end,end
for j=1:10, for F=1:no_floors, B+=(loss_floors*F);end,end
MWMF=Lo+10*n*log10 (d) +A+B;
hold on
plot (d,MWMF,'r','linewidth',3,'markersize',8)
%|=====ITUR P1238-7 MODEL=====|
N=10;
for F=1:no_floors, L+=(loss_floors*F);end
ITURP1238_7=20*log10 (f) +N*log10 (d) +L-28;
hold on
plot (d,ITURP1238_7,'g','linewidth',3,'markersize',8)
%|=====IEEE802.11n MODEL=====|
N1=3.5;
dBp=7;
IEEE802_11n=Freespace_loss+10*N1*log10 (d/dBp);
hold on
plot (d, IEEE802_11n,'m','linewidth',3,'markersize',8)
%|=====ITU-R M2135-1 MODEL=====|
ITUR_2135LOS=16.9*log10 (d) +32.8+20*log10 (f);
```



```
ITUR_2135NLOS=43.3*log10 (d) +11.5+20*log10 (f);  
hold on  
plot (d,ITUR_2135LOS,'b','linewidth',3,'markersize',8)  
hold on  
plot (d,ITUR_2135NLOS,'c','linewidth',3,'markersize',8)  
title ('Comparison of different indoor propagation models')  
xlabel ('Distance in [m]')  
ylabel ('Path loss in [dB]')  
legend('=cost231_MWMMF','=MWMMF','=ITURP1238_7','=IEEE802_11n','=ITUR_2135LOS','=I  
TUR_2135NLOS')  
%|=====END=====|  
end
```

## II. Final thesis

```
function [] =finalthesis()  
%|===== [Developed by DEJENE HURISSA (GSR/0434/05)] =====|  
%|===== [Advisor: Dr.YALEMZELD NEGASH]=====|  
disp ('=====')  
disp ('ADDIS ABABA UNIVERSITY')  
disp ('ADDIS ABABA INSTITUTE OF TECHNOLOGY')  
disp ('DEPARTMENT OF ELECTRICAL AND COMPUTER ENGINEERING')  
disp ('DEPLOYMENT OF LTE FEMTOCELLS IN DEAD ZONE AREAS FOR THE CASE  
OF ADDIS ABABA')  
disp ('=====')  
disp ('Select an option:')  
disp (' 1 - Path loss')  
disp (' 2 - Received power')  
disp (' 3 - Signal to interference plus noise ratio(SINR)')  
disp (' 4 - Channel allocation')  
disp (' 5 - Capacity')
```



```
disp (' 6 - Power control')
disp ('=====')
disp ('Select from the above option')
itype = input("");
switch itype,
case 1
%|=====PATHLOSS MODELS=====|
disp ('In order to calculate the path loss of femtocell and macro cell')
disp ('follow the following steps')
disp ('=====')
no_walls=input ('Enter the number of walls\n');
no_floors=input ('Enter the number of floors\n');
loss_floor=2;
loss_wall=5;
f=1861.5*10^6;
d=-500:1:-1;
d2=1:1:100;
r=1:1:100;
n=1.9;
pi=3.14;c=3*10^8;lamda=f/c;
Lo=20*log10 (4*pi/lamda);
F1=17+4*(no_floors-1);
macro_PLOS=133.3-33.94*log10 (d);
macro_PNLOS=133.3-33.94*log10 (d) +10*log10 (F1) +no_walls*loss_wall;
macro_PLOS2=133.3+33.94*log10 (d2);
macro_PNLOS2=133.3+33.94*log10 (d2) +10*log10 (F1) +no_walls*loss_wall;
for W=1:no_walls, A+=(loss_wall*W);end
for F=1:no_floors, B+=(loss_floor*F);end
femto_PLOS=Lo+10*n*log10(r);
```



```
femto_PNLOS=Lo+10*n*log10(r) +A+B;
hold on
grid on
plot (d,macro_PLOS,'b','linewidth',4,'markersize',8)
hold on
plot (d,macro_PNLOS,'r','linewidth',4,'markersize',8)
hold on
plot(r, femto_PLOS,'k','linewidth',4,'markersize',8)
hold on
plot(r,femto_PNLOS,'m','linewidth',4,'markersize',8)
hold on
plot (d2,macro_PLOS2,'b','linewidth',4,'markersize',8)
hold on
plot (d2,macro_PNLOS2,'r','linewidth',4,'markersize',8)
title('Comparison of path loss for femtocell and macro cell')
xlabel ('Distance in [m]')
ylabel ('Path loss [dB]')
legend ('=Path loss of macro cell(LOS)', '= path loss of macro cell(NLOS)', '=path loss of femtocell(LOS)', '=path loss of femtocell(NLOS)');
case 2
%|=====RECEIVED SIGNAL POWER=====|
disp ('In order to calculate the received power of femtocell and macrocell')
disp ('follow the following steps')
disp ('=====')
no_walls=input ('Enter the number of walls\n');
no_floors=input ('Enter the number of floors\n');
loss_wall=5;
loss_floor=2;
f=1861.5*10^6;
```



```
d=-500:1:-1;
d2=1:1:100;
r=1:1:100;
TP_macroBS=16;
TP_femtoBS=-10;
G_macroBS=15;
G_femtoBS= 2;
G_femtoMS=5;
G_macroMS=1;
n=1.9;
pi=3.14; c=3*10^8;
lamda=f/c;
Lo=20*log10 (4*pi/lamda);
F1=17+4*(no_floors-1);
macro_PLOS=133.3-33.94*log10 (d);
macro_PNLOS=133.3-33.94*log10 (d) +10*log10 (F1) +no_walls*loss_wall;
macro_PLOS2=133.3+33.94*log10 (d2);
macro_PNLOS2=133.3+33.94*log10 (d2) +10*log10 (F1) +no_walls*loss_wall;
for W=1:no_walls, A=+(loss_wall*W);end
for F=1:no_floors, B=+(loss_floor*F);end
femto_PLOS=Lo+10*n*log10(r);
femto_PNLOS=Lo+10*n*log10(r)+A+B;
RP_macro= (TP_macroBS*G_macroBS*G_macroMS. /macro_PNLOS);
RPlos_macro= (TP_macroBS*G_macroBS*G_macroMS. /macro_PLOS);
RP_femto=-TP_femtoBS*G_femtoBS*G_femtoMS. /femto_PNLOS;
RPlos_femto=-TP_femtoBS*G_femtoBS*G_femtoMS. /femto_PLOS;
RP_macro2= (TP_macroBS*G_macroBS*G_macroMS. /macro_PNLOS2);
RPlos_macro2= (TP_macroBS*G_macroBS*G_macroMS. /macro_PLOS2);
plot (d, RP_macro,'b','linewidth',4,'markersize',8)
```



```
hold on
grid on
plot (d,RPlos_macro,'r','linewidth',4,'markersize',8)
hold on
Plot(r, RP_femto,'k','linewidth',4,'markersize',8)
hold on
plot(r,RPlos_femto,'g','linewidth',4,'markersize',8)
hold on
plot (d2,RP_macro2,'b','linewidth',4,'markersize',8)
hold on
plot (d2,RPlos_macro2,'r','linewidth',4,'markersize',8)
title('Comparison of received signal for femtocell and macro cell')
xlabel ('Distance in [m]')
ylabel ('Received signal in [dB]')
legend ('= Received power of macro cell(NLOS)', '= Received power of macro
cell(LOS)', '=Received power of femtocell(NLOS)', '=Received power of femtocell(LOS)');
case 3
%|-----SINR-----|
disp ('In order to calculate signal to interference plus noise ratio(SINR)')
disp ('follow the following steps')
disp ('=====')
disp ('Select an option:')
disp (' 1 - SINR of macro cell interfered by macro and femtocells')
disp (' 2 - SINR of femtocell interfered by macro and femtocells')
disp (' 3 -Comparison of SINR for macro interfered by macro cells only and femto interfered by
femtocells only ')
disp ('=====')
disp ('Select from the above options')
itype = input ('');
```



```
switch itype,
case 1
%|=====SINR of macro cell=====|
no_walls=input ('Enter the number of walls\n');
no_floors=input ('Enter the number of floors\n');
loss_wall=5;
loss_floor=2;
d=0:1:100;
r=0:1:100;
n=1.9;
pi=3.14; c=3*10^8;
NO=3.98*10^-21;
fo=10*log10 (15*1000);
f=1861.5*10^6;
TP_macroBS=16;
TP_femtoBS=-10;
spect=10*log10(NO*fo);
lamda=f/c;
Lo=20*log10 (4*pi/lamda);
F1=17+4*(no_floors-1);
macro_PNLOS=133.3+33.94*log10 (d) +10*log10 (F1) +no_walls*loss_wall;
for W=1:no_walls, A+=(loss_wall*W);end
for F=1:no_floors, B+=(loss_floor*F);end
femto_PNLOS=Lo+10*n*log10(r) +A+B;
Z=input ('Enter the number of interfering macro cells\n');
Y=input ('Enter the number of interfering femtocells\n');
for M=1: Z
G_macroBS=macro_PNLOS;
C+= ((TP_macroBS*M)*(G_macroBS*M));
```



```
end
for G=1:Y
G_femtoBS=femto_PNLOS;
D=+ ((TP_femtoBS*G)*(G_femtoBS*G));
end
macro_SINR1=-(TP_macroBS*G_macroBS)./(spect+D);
macro_SINR2=-(TP_macroBS*G_macroBS)./(spect+C);
macro_SINR3=-(TP_macroBS*G_macroBS)./(spect+C+D);
grid on
hold on
plot (d,macro_SINR1,'r','linewidth',4,'markersize',8)
hold on
plot (d,macro_SINR2,'b','linewidth',4,'markersize',8)
hold on
plot (d,macro_SINR3,'k','linewidth',4,'markersize',8)
title (' SINR of macro cell')
xlabel ('Distance in [m]')
ylabel ('SINR in [dB]')
legend ( '=SINR1 of macro cell with[FI] ','=SINR2 of macro cell with[MI]','=SINR3 of macro
cell with[M&FI]')
case 2
%|=====SINR of femtocell=====|
no_walls=input ('Enter the number of walls\n');
no_floors=input ('Enter the number of floors\n');
loss_wall=5;
loss_floor=2;
d=0:1:100;
r=0:1:100;
n=1.9;
```



```
pi=3.14;c=3*10^8;
NO=2.511*10^14;
fo=10*log10 (15*1000);
f=1861.5*10^6;
TP_macroBS=16;
TP_femtoBS=-10;
spect=10*log10 (NO*fo);
lamda=f/c;
Lo=20*log10 (4*pi/lamda);
F1=17+4*(no_floors-1);
macro_PNLOS=133.3+33.94*log10 (d) +10*log10 (F1) +no_walls*loss_wall;
for W=1:no_walls, A+=(loss_wall*W);end
for F=1:no_floors, B+=(loss_floor*F);end
femto_PNLOS=Lo+10*n*log10(r) +A+B;
Z=input ('Enter the number of interfering macro cells\n');
Y=input ('Enter the number of interfering femtocells\n');
for X=1:Y
G_macroBS=macro_PNLOS;
E+= ((TP_macroBS*X)*(G_macroBS*X));
end
for W=1: Z
G_femtoBS=femto_PNLOS;
F+= ((TP_femtoBS*W)*(G_femtoBS*W));
end
Femto_SINR1= (TP_femtoBS*G_femtoBS). / (spect+F);
Femto_SINR2= (TP_femtoBS*G_femtoBS). / (spect+E);
Femto_SINR3= (TP_femtoBS*G_femtoBS). / (spect+F+E);
grid on
hold on
```



```
plot(r, Femto_SINR1,'b','linewidth',4,'markersize',8)
hold on
plot(r, Femto_SINR2,'r','linewidth',4,'markersize',8)
hold on
plot(r,Femto_SINR3,'k','linewidth',4,'markersize',8)
hold on
title ('SINR of femtocell')
xlabel ('Distance in [m]')
ylabel ('SINR in [dB]')
legend ( '=SINR1 of femtocell with[FI] ', '=SINR2 of femtocell with[MI]', '=SINR3 of femtocell with[M&FI]')
case 3
%|=====SINR of macro and femtocell=====|
no_walls=input ('Enter the number of walls\n');
no_floors=input ('Enter the number of floors\n');
loss_wall=5;
loss_floor=2;
d=-500:1:0;
r=0:1:100;
n=1.9;
pi=3.14;c=3*10^8;
NO=2.511*10^14;
fo=10*log10 (15*1000);
f=1861.5*10^6;
TP_macroBS=16;
TP_femtoBS=-10;
spect=10*log10 (NO*fo);
lamda=f/c;
Lo=20*log10 (4*pi/lamda);
```



```
F1=17+4*(no_floors-1);
macro_PNLOS=133.3+33.94*log10 (d) +10*log10 (F1) +no_walls*loss_wall;
for W=1:no_walls, A+=(loss_wall*W);end
for F=1:no_floors, B+=(loss_floor*F);end
femto_PNLOS=Lo+10*n*log10(r) +A+B;
Z=input ('Enter the number of interfering macro cells\n');
F=input ('Enter the number of interfering femtocells\n');
for M=1: Z
G_macroBS=macro_PNLOS;
C+= ((TP_macroBS*M)*(G_macroBS*M));
end
for W=1:F
G_femtoBS=femto_PNLOS;
F+= ((TP_femtoBS*W)*(G_femtoBS*W));
end
macro_SINR= (TP_macroBS*G_macroBS). / (spect+C);
Femto_SINR= (TP_femtoBS*G_femtoBS). / (spect+F);
grid on
hold on
plot (d,macro_SINR,'b','linewidth',4,'markersize',8)
hold on
plot(r, Femto_SINR,'r','linewidth',4,'markersize',8)
title ('SINR of macro cell and femtocell')
xlabel ('Distance in [m]')
ylabel ('SINR in [dB]')
legend ( '=SINR of macro cell', '=SINR of femtocell')
end
case 4
%|=====RANDOM CHANNEL ALLOCATION=====|
```



```
disp ('In order to see channel allocation of spectrum ')
disp ('follow the following steps')
disp('=====')
Area=input ('Enter the total area\n');
F_area=input ('Enter femtocell coverage area\n');
no_femtoells=Area/F_area;
numero fusers=no_femtoells*6;
share=ceil (720/numero fusers);
h=randi(1024,1,share);
disp(„The random channel assignment is=‘)
disp (h);
case 5
%|=====CAPACIT=====|
disp ('In order to calculate the capacity of femtocell and macro cell using 16QAM modulation
technique')
disp ('follow the following steps')
disp ('=====')
Count = 1000;
%|=====PATHLOSS=====|
no_walls=input ('Enter the number of walls\n');
no_floors=input ('Enter the number of floors\n');
loss_wall=5;
loss_floor=2;
d=100;
r=100;
n=1.9;
pi=3.14;c=3*10^8;
NO=2.511*10^14;
fo=10*log10 (15*1000);
```



```
f=1861.5*10^6;
TP_macroBS=16;
TP_femtoBS=-10;
spect=10*log10 (NO*fo);
lamda=f/c;
Lo=20*log10 (4*pi/lamda);
F1=17+4*(no_floors-1);
macro_PNLOS=133.3+33.94*log10 (d) +10*log10 (F1) +no_walls*loss_wall;
for W=1:no_walls, A+=(loss_wall*W);end
for F=1:no_floors, B+=(loss_floor*F);end
femto_PNLOS=Lo+10*n*log10(r) +A+B;
Z=input ('Enter the number of interfering macro cells\n');
Y=input ('Enter the number of interfering femtocells\n');
for X=1: Y
G_macroBS=macro_PNLOS;
E+= ((TP_macroBS*X)*(G_macroBS*X));
end
for W=1:Z
G_femtoBS=femto_PNLOS;
F+= ((TP_femtoBS*W)*(G_femtoBS*W));
end
Femto_SINR1= (TP_femtoBS*G_femtoBS). / (spect+F);
Femto_SINR2= (TP_femtoBS*G_femtoBS). / (spect+F+E);
channel = sqrt(1/2)*(randn(1,Count)+1i*randn(1,Count));
FNoise_generated = 1/ (10. ^ (Femto_SINR1/10));
F2Noise_generated = 1/ (10. ^ (Femto_SINR2/10));
Fnoise = sqrt (FNoise_generated/2)*(randn (1, Count) +1i*randn (1, Count));
F2noise = sqrt (F2Noise_generated/2)*(randn (1, Count) +1i*randn (1, Count));
%|=====Capacity[16PSK] of femtocell interfered by femtocells=====|
```



```
FM_16psk = sqrt(1/10)*[-3+3*1i, -1+3*1i, +1+3*1i, +3+3*1i, -3+1*1i, -1+1*1i, +1+1*1i,  
+3+1*1i, -3-1*1i, -1-1*1i, +1-1*1i, +3-1*1i, -3-3*1i, -1-3*1i, +1-3*1i, +3-3*1i];  
Fcipher16 = ceil (length (FM_16psk)*rand (1, Count));  
FT_signal16 = FM_16psk (Fcipher16);  
FR_signal16 = FT_signal16.*channel+Fnoise;  
FP_random16 = max (exp (-(abs (ones (length (FM_16psk), 1)*FR_signal16 -  
FM_16psk.*channel). ^2)/FNoise_generated), realmin);  
FNP_random16 = FP_random16. / (ones (length (FM_16psk), 1)*sum (FP_random16));  
FData_rate16 = log2 (length (FM_16psk)) + mean (sum (FNP_random16.*log2  
(FP_random16)));  
disp (['Capacity of femtocell interfered by femtocells=', num2str(FData_rate16)]);  
%|=====Capacity[16PSK] of femtocell interfered by macro and femtocells=====|  
F2M_16psk = sqrt(1/10)*[-3+3*1i, -1+3*1i, +1+3*1i, +3+3*1i, -3+1*1i, -1+1*1i, +1+1*1i,  
+3+1*1i, -3-1*1i, -1-1*1i, +1-1*1i, +3-1*1i, -3-3*1i, -1-3*1i, +1-3*1i, +3-3*1i];  
F2cipher16 = ceil (length (F2M_16psk)*rand (1, Count));  
F2T_signal16 = F2M_16psk (F2cipher16);  
F2R_signal16 = F2T_signal16.*channel+F2noise;  
F2P_random16 = max (exp (-(abs (ones (length (F2M_16psk), 1)*F2R_signal16 -  
F2M_16psk.*channel). ^2)/F2Noise_generated), realmin);  
F2NP_random16 = F2P_random16. / (ones (length (F2M_16psk), 1)*sum (F2P_random16));  
F2Data_rate16 = log2  
(length(F2M_16psk))+mean(sum(F2NP_random16.*log2(F2P_random16)));  
disp (['Capacity of femtocell interfered by macro and femtocells=', num2str(F2Data_rate16)]);  
case 6  
%=====POWER CONTROL=====|  
disp ('In order to analyze the power control of macro cell and femtocell')  
disp ('follow the following steps')  
disp ('=====')  
rc=input('Enter the radius of femto cell\n');
```



```
rmax=input('Enter the maximum theoretical radius of femto cell \n');
rue=input ('Enter the radius of the outer most placed user equipment of femtocell \n');
HO=input('Enter handover request for no handover HO=0 \n');
if (HO==0&&rue<rc&&rc<=rmax)
    rc=rc+1;
else if(HO~=0&&rue<rc&&rc<=rmax)
    rc=rue;
else
end
d=input ('Enter the distance of macro user equipment \n');
if (d<100)
    TP_macro=0.5;
else if(d<200&&d>=100)
    TP_macro=0.1;
else if(d<300&&d>=200)
    TP_macro =0.15;
else if(d<400&&d>=300)
    TP_macro=0.2;
else if(d<500&&d>=400)
    TP_macro =0.25;
else if(d<600&&d>=500)
    TP_macro=0.3;
else if(d<700&&d>=600)
    TP_macro=0.35;
else if(d<800&&d>=700)
    TP_macro=0.4;
else if(d<900&&d>=800)
    TP_macro=0.45;
else if(d>=900)
```



```
TP_macro=0.5;  
end  
disp ('The recommended macro power for the given distance is=');  
disp (TP_macro)  
disp ('The radius of femtocell after power adjustment is=')  
disp (rc)  
%|-----END-----|  
end
```



**AAiT**

Addis Ababa Institute of Technology  
አዲስ አበባ ቴክኖሎጂ ዲፕሎማ  
Addis Ababa University  
አዲስ አበባ ዩኒቨርሲቲ