



**ADDIS ABABA UNIVERSITY
SCHOOL OF GRADUATE STUDIES
ADDIS ABABA INSTITUTE OF TECHNOLOGY
DEPARTMENT OF CIVIL ENGINEERING**

**SOAKED CBR VALUE DETERMINATION FROM
LABORATORY DCP TEST FOR ADDIS ABABA RED
CLAY SOIL**

**A Thesis Submitted to the School of Graduate Studies in Partial
Fulfillment of the Requirement for the Degree of Master of Science
in Civil Engineering**

**By
Ashenafi Mulugeta**

June, 2016

**ADDIS ABABA UNIVERSITY
SCHOOL OF GRADUATE STUDIES
ADDIS ABABA INSTITUTE OF TECHNOLOGY
DEPARTMENT OF CIVIL ENGINEERING**

**SOAKED CBR VALUE DETERMINATION FROM
LABORATORY DCP TEST FOR ADDIS ABABA RED CLAY
SOIL**

**MSc Thesis
By
Ashenafi Mulugeta**

Approved by the Board of Examiners

Dr.Ing. Samuel Tadesse
(Advisor)

(Signature)

(Date)

Prof. Alemayehu Teferra
(External Examiner)

(Signature)

(Date)

Dr. Henok Fikre
(Internal Examiner)

(Signature)

(Date)

Dr. Agizew Negussie
(Chairman)

(Signature)

(Date)

ACKNOWLEDGEMENTS

First of all I would like to praise my God, my Lord, my Savior Jesus Christ, who gave me the courage to complete this research work.

Secondly my special thanks goes to my advisor Dr.Ing. Samuel Tadesse for guiding and supervising my research work.

I would like also to thank Ethiopian Roads Authority for sponsoring my study and Best Consulting Engineers Plc and Gemta Construction and Consulting Engineers Plc for their valuable supports during my study.

Last but not least, I would like to thank my fiancé Wongel Gedeon and my friends Ermias Genye, Tewodros Gebru and Tizazu Sima for their encouragement during my study.

Abstract

The CBR test is the most widespread method of determining the bearing strength of pavement materials and is fundamental to pavement design. Almost all road construction manuals of Ethiopia recommend CBR tests for flexible pavement constructions. However, most of low volume roads such as roads built under Universal Rural Road Access Program (URRAP) have been designed, constructed and maintained without performing the required CBR tests. One of the cited reason is that CBR is an expensive test.

Hence, this thesis is aimed to introduce the simplest and cheapest way of determining the required CBR values indirectly using DCP tests. In this study DCPI values obtained from the laboratory prepared samples were correlated with soaked CBR values for Addis Ababa red clay soils. In laboratory both CBR and DCP tests were conducted on soil samples remolded in standard CBR molds. The tests were performed for both soaked and un-soaked conditions. Besides, the appropriate soil index tests were conducted for all of the samples.

The data analysis was made using a statistical software called SPSS, and a good correlation was obtained between soaked CBR and soaked DCP values and change in moisture content. Using a multiple linear regression for 21 samples, the following empirical equation was developed with 72.9% coefficient of determination.

$$S_CBR = -0.53(CH_DCP_moist) - 0.22(S_DCP) + 19.49$$

-where; S_CBR and S_DCP are to mean that Soaked CBR and Soaked DCP respectively, and CH_DCP_moist is the difference between the water contents of the sample before & after soaking the remolded sample for DCP tests.

Contents

ACKNOWLEDGEMENT

Abstract

ABBREVIATIONS, ACRONYMS AND SYMBOLS.....	i
1. Introduction:	1
1.1 General	1
1.2 Back ground of the problem	1
1.3 Objective	2
1.3.1 General Objective	2
1.3.2 Specific Objective	2
1.4 Methodology	2
1.5 Scope of the Study	3
1.6 Structure of the thesis	3
2. Literature Review	4
2.1 General	4
2.2 California Bearing Ratio (CBR)	4
2.2.1 Test Methods	5
2.2.2 Calculations	6
2.2.3 Significance and Use	7
2.2.4 Limitations	7
2.3 Laboratory Dynamic Cone Penetrometer (DCP) Test	8
2.3.1 Test Methods	9
2.3.2 Calculations	10
2.3.3 Significance and Use	11
2.3.4 Limitations	11
2.4 Correlations between DCP and CBR	12
2.4.1 General	12
2.4.2 Correlations between laboratory DCP and CBR	13
3. Sample Collection and Test Methods	15
3.1 Description of the study area	15
3.2 Test Methods	16
3.3 Test Results	17

3.4	Summary of Test Results.....	20
3.5	Discussion of Test Results	24
4.	Data Analysis	25
4.1	General	25
4.2	Scatter Diagram	25
4.3	Regression	30
4.4	Procedure of the Analysis	31
5.	Discussion of the Statistical Analysis.....	35
	Validation of the developed Equation.....	36
6.	Conclusion and Recommendation	37
6.1	Conclusion	37
6.2	Recommendation	37
	References	38
	APPENDICES	41
	APPENDIX A – SPECIFIC GRAVITY TEST RESULTS.....	42
	APPENDIX B – ATTERBERG LIMIT TEST RESULTS.....	51
	APPENDIX C – MOISTURE DENSITY RELATIONSHIP TEST RESULTS	76
	APPENDIX D – PARTICLE SIZE ANALYSIS.....	89
	APPENDIX E – DCP TEST RESULTS	114
	APPENDIX F – CBR TEST RESULTS.....	139
	APPENDIX G – SPSS REGRESSION ANALYSIS OUT PUTS	164

Lists of Tables

Table 2.1: Relationships between CBR and DCP.....	12
Table 2.2: Correlation between Laboratory DCP and Laboratory CBR.....	14
Table 2.3: Approximate relationship between laboratory DCP and CBR (2).....	14
Table 3.1: Soil Index test Results.....	20
Table 3.2: Laboratory CBR and Laboratory DCP test Results.....	22
Table 3.3 comparison of test results.....	24
Table 4-1 Correlation Matrix of Pearson Correlation Coefficient.....	32
Table 4.2: Linear Simple Empirical Equations.....	33
Table 4.3: Logarithmic Simple Empirical Equations.....	33
Table 4.4: Multiple Linear Empirical Equations.....	33
Table 4.5: Multiple Logarithmic Empirical Equations.....	34
Table 5.1: validation of the developed Empirical Equation.....	36

Lists of Figures

Fig.2.1 Typical drawings for laboratory CBR and Field tests	5
Fig 2.2 Correction of Load – Penetration Curves.....	7
Fig.2.3 DCP equipment arrangement for conducting tests on CBR mold	9
Fig. 2.4: Penetration depth vs number blows.....	10
Fig 3.1: Sample source Location map.....	15
Fig. 3.2: Typical Liquid Limit graph	17
Fig 3.3: Typical Grain Size Analysis graph.....	18
Fig 3.4: Typical Moisture Density relationship graph	18
Fig 3.5: Typical Load Vs Penetration graph for CBR (1-point) test.....	19
Fig 3.6: Typical Penetration depth Vs number of blows graph for DCP test.....	19
Fig 4.1: scatter diagram for Soaked CBR VS Soaked DCP.....	25
Fig 4.2 Scatter Diagram Soaked CBR vs Change in DCP.....	26
Fig 4.3 Scatter Diagram Soaked CBR vs Change in DCP-Moisture content.....	26
Fig 4.4 Scatter Diagram Soaked CBR vs Optimum Moisture Content.....	27
Fig 4.5 Scatter Diagram Soaked CBR vs Maximum Dry Density.....	27
Fig 4.6 Scatter Diagram Soaked CBR vs Plastic Index.....	28
Fig 4.7 Scatter Diagram Soaked DCP vs Un-soaked DCP	28
Fig 4.8 Scatter Diagram Soaked DCP vs OMC.....	29
Fig 4.9 Scatter Diagram Soaked DCP vs MDD.....	29
Fig 4.10 Scatter Diagram Soaked DCP vs PI.....	30

ABBREVIATIONS, ACRONYMS AND SYMBOLS

AASHTO	American Association of State Highway and Transportation Officials
ASTM	American Society for Testing of Materials
BC	Blow count
BS	British Standard
CBR	California Bearing Ratio
CBR _{field}	Field California Bearing Ratio
d	depth/diameter
CH_DCP	Change in DCP values (soaked DCP – Un-soaked DCP)
CH_DCP_moist	Change in moisture content of samples prepared for DCP test before and after soaking
DCP	Dynamic Cone Penetrometer
DCPI	Dynamic Cone Penetrometer Index
DD	dry density
gm	gram
gm/cm ³	gram per centimetre cube
Gs	Specific gravity
H	Penetration depth
KN	kilo Newton
KN/DIV	kilo Newton per division
kPa	kilo pascal
LI	Liquidity Index
LL	Liquid Limit
m	meter
MDD	Maximum dry density
mm	millimetre

NMC	natural moisture content
N/A	Not Available
OMC	Optimum moisture content
PI	Plasticity index/ penetration index
PL	Plastic limit
PR	Penetration rate
PR _{field}	Field penetration rate
R ²	Coefficient of determination
S_CBR	Soaked California Bearing Ratio value
S_DCP	Soaked Dynamic Cone Penetrometer value
SPSS	Statistical Package for the Social Sciences
TRRL/TRL	Transport and Road Research Laboratory/ Transport Research Laboratory
UK	United Kingdom
Un_CBR	Un-soaked California Bearing Ratio value
Un_DCP	Un-Soaked Dynamic Cone Penetrometer value
US	United States of America
USCS	Unified Soil Classification System

1. Introduction:

1.1 General

One of the key factors which can indicate whether a country is developed or not is its road density. Hence, nowadays in Ethiopia, road construction has become a highly intensified activity. This construction industry takes the lion's share of the country's economy. Large amount of investment is being placed to this industry to build different kinds of roads starting from earthen roads to express ways.

In road construction, pavement design is a crucial stage, which has to be performed carefully in order to be economical and increase the service period of the road. The most important things to be considered during pavement design, especially for the design of flexible pavements are traffic volume, subgrade strength and weather condition.

Subgrade strength is determined majorly using CBR values. It also plays a key role in fixing flexible pavement thicknesses. Furthermore, suitability of road embankment filling materials is majorly determined by their CBR values.

When compared with the road network of the country the availability of CBR machines in Ethiopia are negligible. Hence, most of low volume roads of the country, such as roads built under URRAP have been constructed without carrying out this test. This could not happen if this expensive testing method had been replaced by another simplified method.

One of the cheapest and easiest way to indirectly determine CBR values is to conduct DCP tests and derive CBR values from the already developed empirical equations. In our country, all published empirical equations with their own limitations, are applicable only for DCP tests conducted in the field. Other African countries for example Malawi and South Africa had already included laboratory DCP test procedures in their road design and construction manuals. [1,7]

Hence, this thesis introduces DCP tests conducted in laboratory and tries to find a way to determine soaked CBR values by generating an empirical equation from laboratory DCP tests.

1.2 Back ground of the problem

Due to the few number of soil laboratories and with their competency limitations in performance, for the past couple of decades our county's soil test laboratories have been overcrowded by soil samples gathered from different parts of the country travelling long distances. CBR tests could not be performed around the project area due to the expensiveness of the machine. Hence significant costs in finance and time are expended during transporting and testing. Furthermore,

due to lack of CBR machines in project areas, most of low volume roads are constructed without carrying out this test. In case of our country, no research has yet been made or published to predict soaked CBR values from laboratory DCP tests.

1.3 Objective

The objectives of the thesis are presented as follows.

1.3.1 General Objective

The general objective of this thesis is to find out a method to determine soaked CBR values using DCP tests conducted in laboratory.

1.3.2 Specific Objective

The specific objectives of this thesis are:

- To conduct CBR and DCP tests on remolded samples in standard CBR molds.
- To develop an empirical equation which correlates DCP with CBR.
- To perform soil index tests and check their relationship with DCP and CBR.

1.4 Methodology

To achieve the objective of this thesis, it is a primary task to carry out literature review regarding CBR, DCP and their relationship. Accordingly, technical papers, journals and published reports related to the subject matter are thoroughly reviewed. After the literature review, the predominant sources of red clay soil of Addis Ababa are identified based on the previous studies of red clay soil. Twenty one red clay soil samples from Shiromeda, Semen Mazegajia, Gullele Park and Asco areas are collected and basic soil index tests such as Atterberg limits, gradation, specific gravity, and proctor tests will be conducted. Then laboratory DCP and laboratory CBR tests would be performed. CBR and DCP tests will be performed for both un-soaked and soaked conditions. The DCP tests will be conducted on remolded samples in CBR molds. A similar initial conditions (the same dry density, moisture content and compaction effort) will be used to prepare a pair of remolded samples in order to conduct each DCP and CBR tests. Then, the test result analysis will be performed and an empirical equation will be developed. Lastly discussions and conclusions will be presented.

1.5 Scope of the Study

This thesis is based on the laboratory CBR and DCP tests conducted for twenty four red clay soil samples collected from North West of Addis Ababa. Statistic regression will be performed using statistic software called SPSS. Twenty one samples shall be used for the correlation and three samples for checking the developed empirical equation.

1.6 Structure of the thesis

This thesis contains six chapters. The introduction Chapter gives a general discussion about the thesis. Here objective and methodology of the thesis are also presented. In Chapter two summary of literature review on CBR and DCP is presented. Chapter three deals with data collection methods and summary of test results. In Chapter four data analysis is presented. In Chapter five discussion is made on the findings of the study. Conclusion and recommendation are presented in the last Chapter, and in final pages, references and appendixes are presented.

2. Literature Review

2.1 General

Dynamic or static penetration tests are widely used in geotechnical engineering. Various penetrometers and testing methods are utilized in soil exploration in response to different purposes and requirements. During the preliminary exploratory phase, penetration tests are employed to determine the soil conditions, such as soil type, the depth, thickness and lateral extent of the soil strata. During the detailed exploration phase, penetration tests are also important. The shear strength and stiffness of the soil can be estimated from penetration testing data, so that the ultimate bearing capacity of the soil can be assessed.

In road constructions, the most widely used laboratory test for evaluating the potential strength of subgrade, subbase, and base course materials is the California Bearing Ratio test. This test method is a simple strength test that compares the bearing capacity of a material with that of a well graded standard crushed stone base kept in California Division of Highways Laboratory.

Another penetration test which can replace CBR test is Dynamic Cone Penetrometer (DCP) test. The Dynamic Cone Penetrometer has been increasingly used for road constructions in many parts of the world due to its simplicity, and cheapness. Furthermore, a lot of empirical equations have been established to correlate the CBR values with DCPI values, which made DCP tests preferable.

2.2 California Bearing Ratio (CBR)

In pavement design, the California Bearing Ratio (CBR) is a very commonly used laboratory test for predicting the strength of a subgrade layer. This test method was first introduced into the California State Highway Department in the 1920's. The US Army Corps of Engineers then adapted the method in the 1940's for military airfields. After the Second World War, the CBR was also used in the UK and its use spread to European countries [4,6]. CBR test was standardized by American Society Of Testing Materials (ASTM) as D1883-05 for laboratory prepared samples or re-molded samples and D4429 for on field soils; and by American Association of State Highway and Transportation officials (AASHTO) T193; and by British Standard as BS 1377 part 4.

The following two typical drawings show that the apparatus and method of testing for CBR tests conducted in laboratory and field.

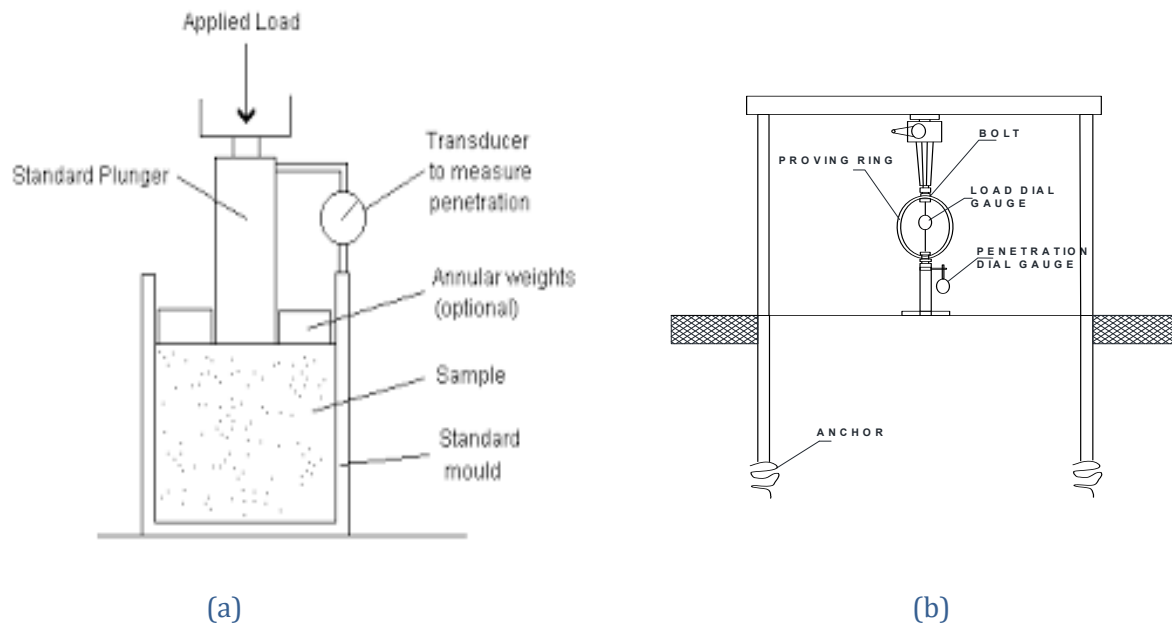

Fig.2.1 Typical drawings for (a) laboratory CBR test apparatus and (b) field CBR test apparatus

2.2.1 Test Methods

The CBR test is performed by measuring the pressure required to penetrate a soil sample with a plunger of standard area. The measured pressure is then divided by the pressure required to achieve an equal penetration on a standard crushed rock material. This test method is primarily intended for but not limited to, evaluating the strength of cohesive materials having maximum particle sizes less than 19mm. If materials having maximum particle sizes greater than 19mm are to be tested, modifying the gradation of the material is applicable so that the material used for tests all passes the 19mm sieve while the total gravel between 4.75mm and 75mm fraction remains the same [2].

CBR test can be performed in field or in laboratory. The laboratory test can be performed on re-molded sample or on undisturbed sample. Remolded samples are prepared at their maximum dry density and optimum moisture content, which are obtained from standard proctor test results.

While performing laboratory CBR test, the force or load required to cause the penetration will be recorded with respect to the standard penetration depths at each 0.5mm penetration, including the load value at 2.54 mm and 5.08 mm until the total penetration is 12.7mm. The penetration resistance load is then plotted against the penetration depth. From the curve, the bearing ratio is calculated by dividing the loads obtained at 2.54 mm and 5.08mm penetrations by their corresponding standard loads, 13.24KN and 19.96KN respectively. If the bearing ratio of 2.54 mm is greater than that of 5.08 mm, the bearing ratio that should be reported for the soil is normally the one at 2.54 mm penetration. Whereas, when the ratio at 5.08 mm penetration is greater, the test is entirely repeated on

a fresh specimen. If the repeated result of 5.08 mm is again greater, the design bearing ratio will be that of 5.08 mm penetration. The higher the bearing ratio indicates the better material strength. [2]

Laboratory CBR tests can be performed for optimum water content or for the range of water contents. The CBR is determined at optimum water content when and where the effect of compaction water content on CBR is small, such as cohesion less, coarse-grained materials, or where an allowance is made for the effect of differing compaction water contents in the design procedure. Whereas, for applications where the effect of compaction water content on CBR is unknown or where it is desired to account for its effect, the CBR is determined for a range of water contents, usually the range of water content permitted for field compaction.

Soaked CBR test is used to simulate the worst scenario that would likely happen to the sample due to wet weathers. Hence, before performing the tests, soaking the remolded samples for four days is mandatory.

2.2.2 Calculations

The following procedure is followed for the calculations of CBR values.

- Plot the load vs penetration curve in natural scale, load on Y-axis and penetration on X-axis
- Check the shape of the curve and if the curve is uniformly convex upwards although the initial portion of the curve may be concave upwards due to surface irregularities make correction by drawing a tangent to the upper curve at the point of contra flexure as shown in figure 2.3 below.
- Take the intersection point of the tangent and the X-axis as the origin.
- Corresponding to the penetration value at which CBR is to be desired, take the corrected load values from the load penetration curve and calculate the CBR from the equation.

$$\text{CBR} = \frac{P_T}{P_s} \times 100$$

Where, P_T : corrected unit test load in KN corresponding to 2.54mm or 5.08mm penetration from load penetration curve (the product of dial reading and proving ring correction factor)

P_s : 13.24KN for 2.54mm penetration depth, or
19.96KN for 5.08mm penetration depth

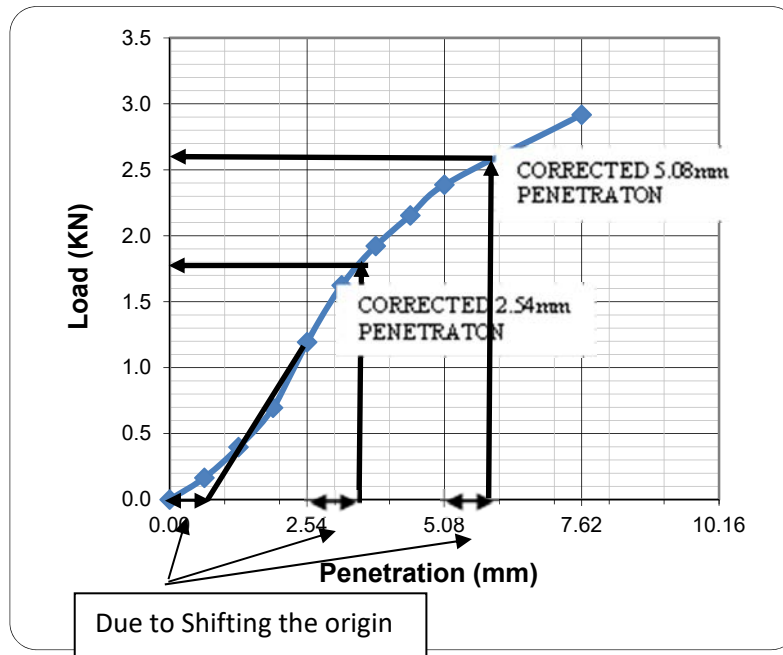

Fig 2.2 Correction of Load – Penetration Curves

2.2.3 Significance and Use

- In road constructions CBR test is used to evaluate the potential strength of subgrade, subbase, and base course materials. Using the subgrade CBR values the thickness of the proposed road layers is determined.
- Together with other soil indices, CBR values are used to check the suitability of construction materials for the road fill.
- To rate the condition of an existing pavement for maintenance or upgrading demand of the road.

2.2.4 Limitations

- The test method is primarily intended for but not limited to, evaluating the strength of cohesive materials having maximum particle sizes less than 19mm.
- When materials having maximum particle sizes greater than 19mm are to be tested, this test method provides for modifying the gradation of the material so that the material used for tests all passes the 19mm sieve while the total gravel fraction remains the same.
- Past practice has shown that CBR results for those materials having substantial percentages of particles retained on the 4.75mm sieve are more variable than for finer materials.

2.3 Laboratory Dynamic Cone Penetrometer (DCP) Test

The invention of Dynamic Cone Penetrometer (DCP) goes back to 1950s. In Australia in 1956, Scala developed DCP to evaluate the shear strength of material in a pavement. This consisted of a 9 kg mass dropping 508 mm and knocking a cone with a 30° point into the material being tested. In his study, Scala tried to find the correlations between DCP test results and CBR, and between DCP test results and the bearing capacity of soils estimated by a static cone. He also proposed a pavement design method based on the DCP/CBR relationship for broad range of subgrade soil. [18]

In 1969, Van Vuuren introduced a 10 kg falling weight through 460 mm height with 30° cone and a 16 mm diameter penetration shaft. He carried out tests for a range of soil types and showed that it was not suitable for coarse sand. Kleyn in 1975 produced a relationship between laboratory CBR and Laboratory DCP. He also discussed various factors affecting the performance of DCP and showed that variability may be occurred due to human factors, mechanical factors and material factors [13]. Then Smith in 1983, Livneh in 1987 and Harrison in 1986 presented their studies on DCP. Harrison used a 60° cone penetrometer to establish a relationship between laboratory CBR and Laboratory DCP for clay like soils, and well graded sand gravel [11]. In 1988, De Beer, Kleyn and Savage developed a universal classification system for thinly surfaced flexible pavements based on DCP test results. In 1987, Transport and Road Research Laboratory (TRRL) developed a relationship between CBR and DCP. In 2004, the American Society for Testing and Materials (ASTM) included DCP test as Standard Test Method (D6951-03) for Use of the Dynamic Cone Penetrometer in Shallow Pavement Applications.

With time a number of variants of DCP equipment were in use, all with different masses, fall-distances and even cone dimensions although the energy imparted was generally similar. The famous and currently used version consists of 8kg weight dropping through a height of 575 mm and a 60° cone having a base diameter of 20 mm as shown in Figure 2.4 below. The top rod is a 16 mm diameter of stainless steel shaft that is threaded at both ends. The stainless steel handle is screwed on one end. The top rod which is calibrated to ensure the drop of the hammer is always 575 mm. The 8-kg hammer is made up of machine steel. The bottom rod which is made of stainless steel is 915 mm in length and 16 mm in diameter. It is threaded at the end so that it can be screwed in to the anvil. The other end of the shaft is also threaded to accept a reusable hardened cone. A steel cone is attached to one end of the DCP which can be driven into the soils. The angle of the cone is 60° and the diameter of the base of the point is 20 mm. the cone is larger than that of the rod to ensure that the resistance to penetration is exerted on the cone without skin friction on the rod. [15, 5]

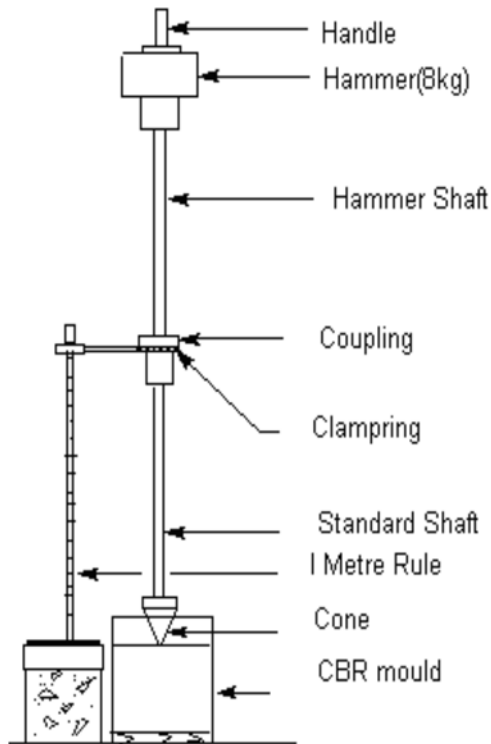

Fig.2.3 DCP equipment arrangement for conducting tests on CBR mold

2.3.1 Test Methods

To perform DCP tests, it needs three operators, one to hold the instrument, one to raise and drop the weight and another to conduct the readings. The penetration of the cone is measured using a calibrated scale and recorded with the number blows required for the penetration. For in-situ tests, it is possible to measure up to 800 mm depth without an extension rod and up to 1200 mm depth when fitted with an extension rod. [16]

Procedures for laboratory DCP tests are summarized as follows [7]:

- Remold the sample in standard CBR mold using the optimum moisture content and maximum dry density values obtained from the previously conducted modified proctor tests.
- Place the full mold on a level floor and place the annular weight on top of the mold.
- Place an empty CBR mold upside down next to the full mold or alternatively use bricks or cement blocks to provide a steady platform for the base of the DCP ruler level with or slightly higher than the top of the full mold.
- Position the tip of the DCP cone in the middle of the CBR mold, hold the DCP in a vertical position, and record the zero reading.

- Knock the cone into the sample and record the readings on the ruler after each blow.
- Continue the blow until just before the tip of the cone touches the base plate and stop there in order not to blunt the cone.
- Lastly determine the DCPI value

2.3.2 Calculations

The following procedure is pursued for the calculations of DCPI values.

- Plot the penetration depth vs number blows curve in natural scale, depth of penetration on Y-axis and number of blows on X-axis
- Calculate the DCPI by calculating the slope of the curve.

$$DCPI = \frac{H}{BC}$$

Where: H = penetration depth, CBR mold depth

BC= total number of blows to reach depth

DCPI= Dynamic Cone Penetrometer Index

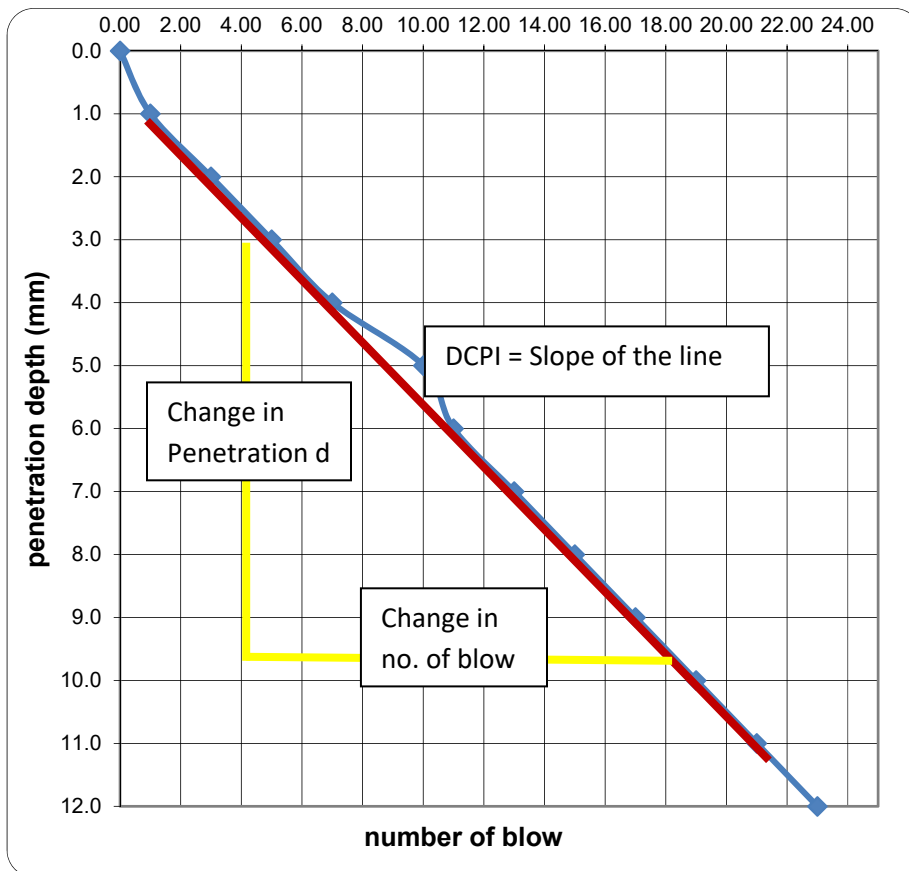

Figure 2.4: Penetration depth vs number blows

During calculating the DCPI, the first blow is usually ignored due to the fact that the imprint area of the cone tip is smaller than that of the subsequent blows.

2.3.3 Significance and Use

The significant advantages of DCP are detailed as following: [7,10]

- Relatively low cost, robust apparatus that is quick and simple to use.
- The simplicity of test allows repeated testing to minimize errors and also to account for temporal effects.
- The DCPI value is determined over a depth of 150mm and not just the top 25 to 50mm as with the CBR test.
- The method is as good as or better than any other method in taking into account variations in moisture content and provides data quickly for analysis.

2.3.4 Limitations

The main limitations that are likely to affect the results and their interpretation and that need to be considered when using laboratory DCP test include:

- Poorly executed tests (hammer not falling the full distance, non-vertical DCP, excessive movement of the depth measuring rod, etc.)
- Changes to standard specifications and the associated bidding documents.

However, the above limitations are controllable if the following measures are taken into account when using the DCP test.

- The equipment must be held vertically at all times. Any deviation from the vertical will result in difficulties in getting repeatable readings from the measuring staff. In addition, the friction effects between the falling mass and the upper rod reduce the energy imparted to the cone.
- The hammer must touch the base of the handle before being released, without jolting the equipment vertically. The hammer should be released to fall under its own mass and not thrown down.
- When testing hard materials, the hammer will often bounce a number of times on the anvil before coming to rest. It should not be lifted for the next drop before coming to total rest.
- The test should start with the upper portion of the shoulder of the cone flush with the surface of the layer being tested
- The cones will suffer from wear and deformation, particularly when testing hard materials, and need to be replaced periodically. Prior to any test, the condition of the cone should be checked to ensure that the point is sharp, the whole cone is screwed into the shaft and the lower surface is not excessively rough.

2.4 Correlations between DCP and CBR

2.4.1 General

The DCP has been successfully utilized for estimating the strength of soils. The DCP was studied mainly in relation to application in pavement structures and was primarily correlated with CBR. A number of studies and investigations such as in-situ or laboratory tests have previously been carried out to make correlations between the DCP and other soil properties. Scala was one of the first investigators who developed the correlation between the DCP and soil strength. He undertook a considerable number of tests in Australia for obtaining the CBR, using static/dynamic cone penetrometers (DCP) [18]. The correlations were presented in blows/inch-CBR curves from DCP tests, and the bearing-capacity-CBR curve from static cone penetration tests.

Other than Scala, studies regarding the CBR and DCP relationships have also been made by researchers around the globe, few of these correlations as detailed by Shin Wu and Shad Sargand [19] are presented as follows.

Empirical Equation	Researcher
$\text{Log (CBR)}=2.56 - 1.15 \text{ Log (DCPI)}$	Austrian Road Research Board/ Smith and Pratt, 1983
$\text{Log (CBR)}=2.64 - 1.08 \text{ Log (DCPI)}$	North Carolina Department of Transportation, 1987
$\text{Log (CBR)}=2.20 - 0.7 [\text{Log (DCPI)}]^{1.5}$	Southeast Asian Geotechnical Conference/ Livneh, 1987
$\text{Log (CBR)}=2.81 - 1.32 \text{ Log (DCPI)}$	Harison, 1989
$\text{Log (CBR)}=2.465 - 1.12 \text{ Log (DCPI)}$	U.S. Army Corps of Engineers/ Webster, Grau and Williams, 1992
$\text{CBR} = 1/(0.002871\text{DCPI})$...for high plasticity clay soil	Webster, Brown and Porter, 1994
$\text{CBR} = 1/(0.017019\text{DCPI})^2$...for high plasticity clay soil	Webster, Brown and Porter, 1994
$\text{Log (CBR)}=2.62 - 1.27 \text{ Log (DCPI)}$	Kleyn, 1992
$\text{Log (CBR)}=2.20 - 0.71 \text{ Log (DCPI)}$	Livneh, Ishai, and Livneh, 1992
$\text{Log (CBR)}=2.669 - 1.065 \text{ Log (DCPI)}$	Fourth International Conference on Bearing Capacity of Roads and Airfields/ Ese, Myre, Noss, and Vaemes, 1994

Table 2.1: Relationships between CBR and DCP, which were made by different researchers

The Ethiopian Roads Authority in its Pavement design manual presented a DCP correlation which is drafted from TRL [16]. Although this correlation was not developed for local soils, it has been used as the only means to estimate CBR values from the in-situ DCP tests.

$$\text{Log (CBR)} = 2.48 - 1.057 \text{ Log (DCPI)}$$

Furthermore, two researchers of Addis Ababa University, Ermias Geneye and Yitagesu Desalegn developed empirical equations for the correlation between CBR and DCP of local soils [9, 23].

Ermias Geneye developed an empirical equation based on soaked laboratory CBR and field DCP tests for Addis Ababa red clay soils. His empirical equation is

$$\text{CBR} = -0.133 * (\text{DCPI}) + 21.731 * \text{MDD} + 0.025 * (\text{DCPI} - \text{predicted DCPI}) - 21.351,$$

-where; Predicted DCPI = $-54.311 * g_{\text{bulk}} + 0.474 \text{ NMC} + 102.539$ [9]

Yitagesu Desalegn's empirical equation is based on laboratory CBR with in-situ conditions and field DCP tests conducted for soil samples obtained from Jima – Mizan road section.

$$\text{Log (CBR)} = 2.954 - 1.496 \log (\text{DCPI}) [23]$$

2.4.2 Correlations between laboratory DCP and CBR

A study, which was done in Saudi Arabia [20], has obtained a good correlation between laboratory DCP and laboratory CBR under un-soaked conditions for different soil types ranging from clay to gravely sand with a good coefficient of determination and low standard error estimate. The correlations obtained are presented as follows:

Sample	USCS	Model	R ²	Standard Error of Regression
S2	SP	log CBR = 3.16 - 1.36 log DCP	0.81	0.275
S5	SP-SM	log CBR = 3.57 - 1.86 log DCP	0.83	0.509
S2+S5		log CBR = 3.24 - 1.50 log DCP	0.71	0.503
S4	SM	log CBR = 3.05 - 1.73 log DCP	0.85	0.442
S7	SM	log CBR = 2.70 - 1.35 log DCP	0.87	0.41
S4+S7		log CBR = 2.80 - 1.46 log DCP	0.85	0.426
S3	ML	log CBR = 2.51 - 1.15 log DCP	0.93	0.226
S9	CL	log CBR = 2.55 - 1.31 log DCP	0.96	0.233
S3+S9		log CBR = 2.54 - 1.23 log DCP	0.93	0.261

Table 2.2: Correlation between Laboratory DCP and Laboratory CBR with minor modifications on naming, which is drafted from a research made in Saudi Arabia by Talal Al-Refeai and A. Al-Suhaibani [20]

Another study, which was made in Malawi, provides an approximate guide to the relationship between the laboratory DCP values and laboratory CBR values for different kinds of soils at varying moisture contents. The following table, which was drafted from the Malawi pavement design manual, shows the relation between laboratory DCP and CBR.[7].

Material Classification	CBR and DCPI values at moisture content					
	Soaked		OMC		0.75 OMC	
	CBR	DCP	CBR	DCP	CBR	DCP
NG80	80	3.7	95	3.2	150	2.2
NG65	65	4.5	90	3.8	145	2.5
NG45	45	5.7	70	4.2	110	3.0
NG30	30	8.0	60	4.7	95	3.2
NG25	25	9.1	55	5.0	85	3.5
NG15	15	14.0	50	5.4	80	3.6
NG10	10	19.0	35	7.0	60	4.6

Table 2.3: Approximate relationship between laboratory DCP and CBR values at varying moisture content

However, in Ethiopian road construction sector laboratory DCP tests have not yet been practiced, hence the author of this study couldn't find any publication which correlates laboratory CBR with laboratory DCP for both soaked and un-soaked conditions of local soils.

3. Sample Collection and Test Methods

3.1 Description of the study area

This thesis was prepared based on the Addis Ababa red clay soils. The predominant red clay sources of Addis Ababa were identified based on the previous studies conducted on the same soil type of the city. Accordingly, disturbed red clay soil samples were collected from North West parts of the city, where the red clay soil is predominant, specifically from Shiromeda, Semen Mazegajia, Gullele Park and Asco areas. Twenty four red clay soil samples were collected and twenty one of them were used for correlation, while three of them were used for checking the developed empirical equation. Their specific locations are mapped in Fig 3.1.

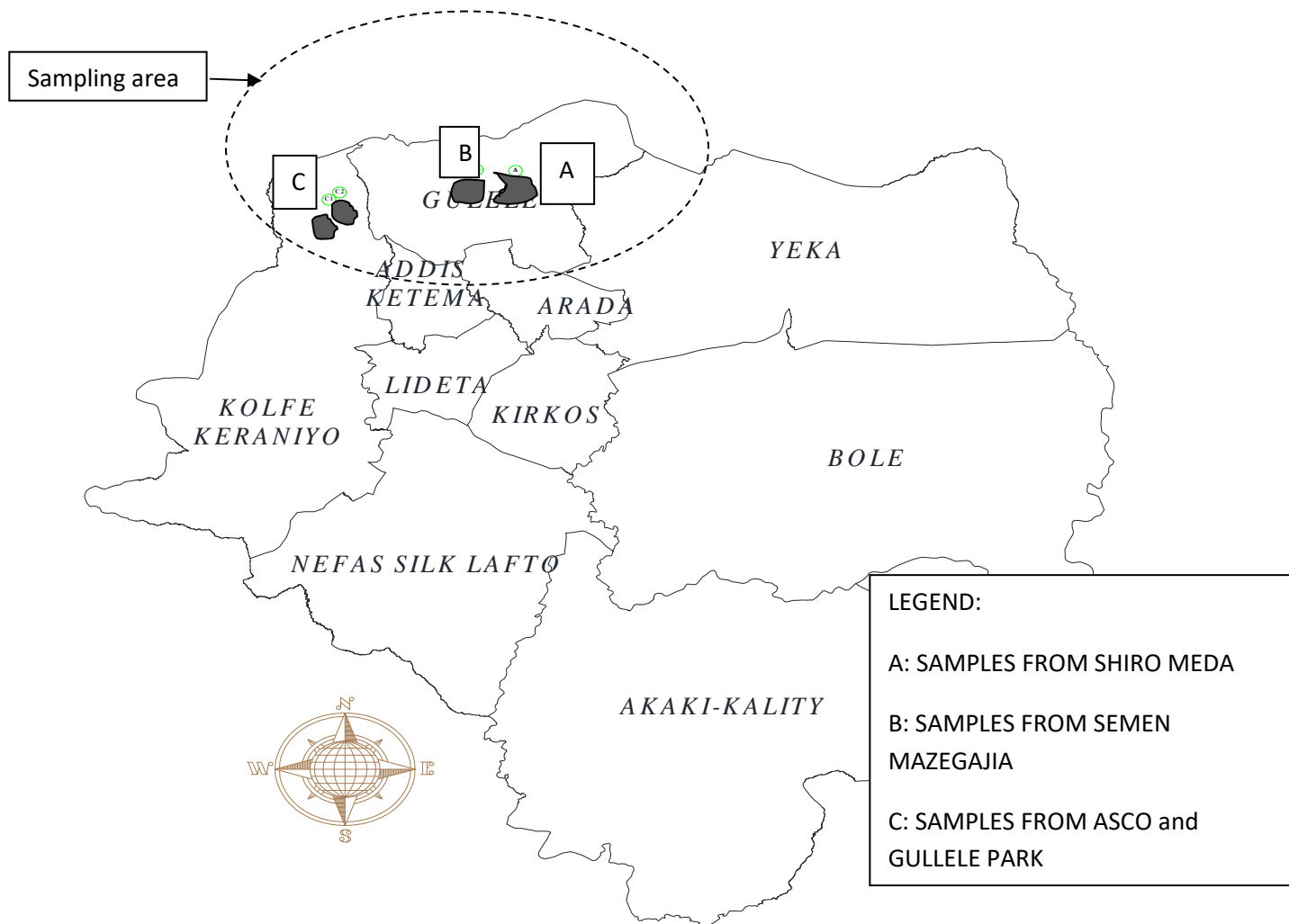

Fig 3.1: Source Location map of the samples

3.2 Test Methods

Sampling was performed by digging test pits by pickaxe and shovel. After removing the overburden soil, the representative soil samples were carefully collected in bags and transported to Addis Ababa University laboratory. For each samples visual identifications were done on site. Sample preparations for the tests to be conducted were made in the premises of the laboratory. Then laboratory tests were performed in three phases.

Primarily, soil index tests were performed to identify and classify the soil. The tests performed under this phase are presented as follows:

- Specific gravity using AASHTO T-100
- Atterberg limit using AASHTO T-89&90
- Soil gradation test using AASHTO T-88

In the second phase, the relationship between moisture content and dry density of each soil samples was determined using Modified proctor test. This test was made using the test procedure presented under AASHTO T-180 (Method B). From this test, maximum dry density and optimum moisture content were determined. These values were used as an input for preparing samples for CBR and DCP tests, which were performed in the third phase.

In the final phase, CBR and DCP tests were conducted. Both tests were performed in laboratory by remolding the samples in standard CBR molds at their optimum moisture content and maximum dry density. From a sample four remolded samples were prepared using a similar scenario in order to get a similar moisture content and dry density. From these four remolded samples two of them were soaked for four days to conduct tests under soaked condition and the remaining two samples were used to conduct un-soaked CBR test and un-soaked DCP test. One remolded sample was used to conduct one kind of test.

- CBR Test

One point CBR test was performed using the test procedure of AASHTO T-193. This test was made for both un-soaked and soaked conditions. Un-soaked CBR test was conducted on one of the pair samples immediately after remolding the samples and soaked CBR test was conducted on the remaining remolded sample after soaking it for four days. Moisture contents were determined for both the un-soaked and soaked samples.

- DCP Test

This test followed the test procedure presented under ASTM D6951-03 except here the penetration was performed on remolded samples in laboratory. Remolding the samples was performed in standard CBR molds. The DCP was directly placed at the surface in the center of the remolded sample with the same surcharge load used in CBR tests. The DCP test was then started by sliding the hammer while measuring the soil resistance to penetration in terms of mm/blow. Similar to the CBR tests, Un-soaked DCP test was conducted on one of the pair samples immediately after remolding the samples and soaked DCP test was conducted on the remaining remolded sample after soaking it for four days. Here also Moisture contents were determined for both the un-soaked and soaked samples.

3.3 Test Results

For the sake of visualizing the test results, typical test results are presented in the figures below. The details are presented in the relevant appendices.

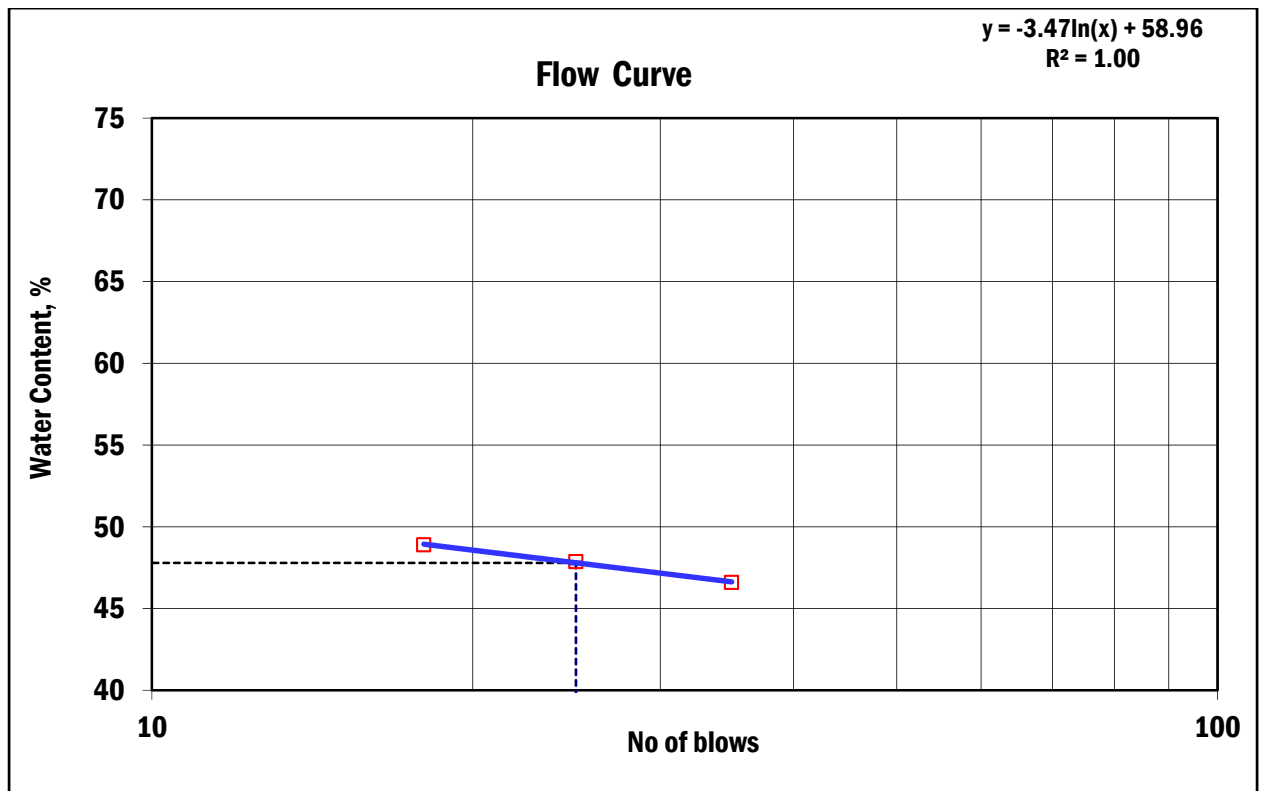

Fig. 3.2: Typical Liquid Limit graph (sample No 13)

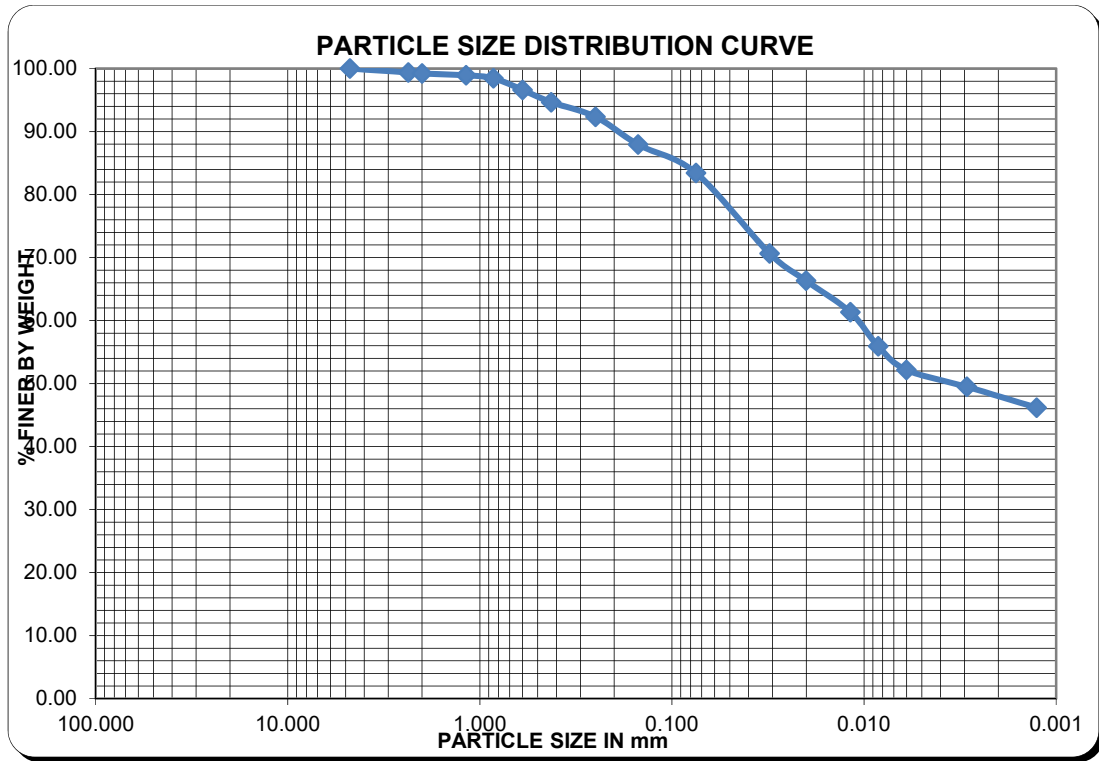

Fig 3.3: Typical Grain Size Analysis graph (sample no 13)

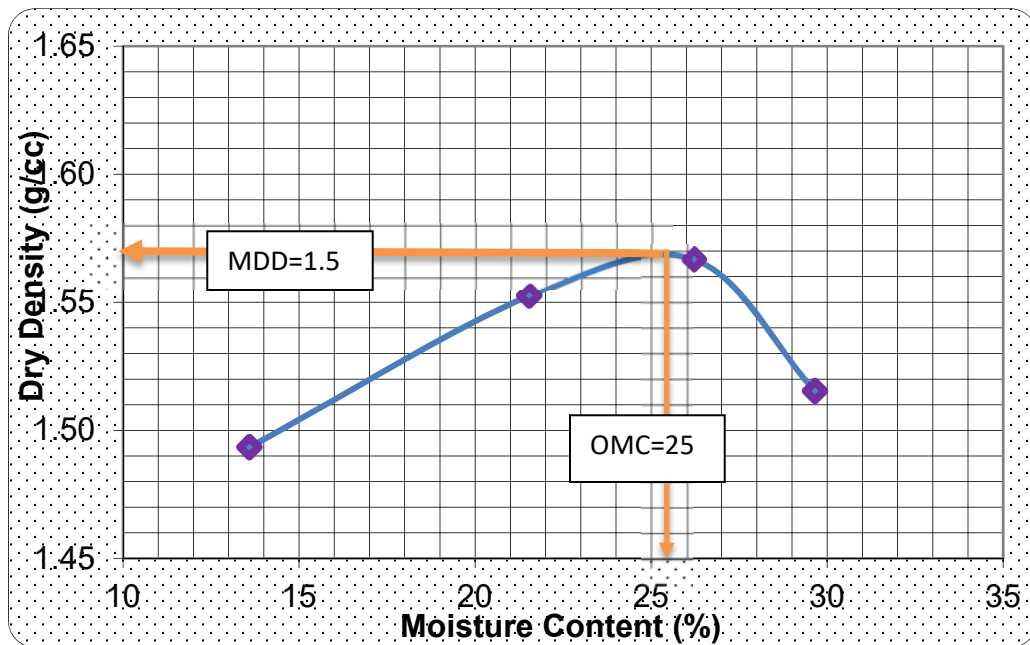

Fig 3.4: Typical Moisture Density relationship graph (sample no 13)

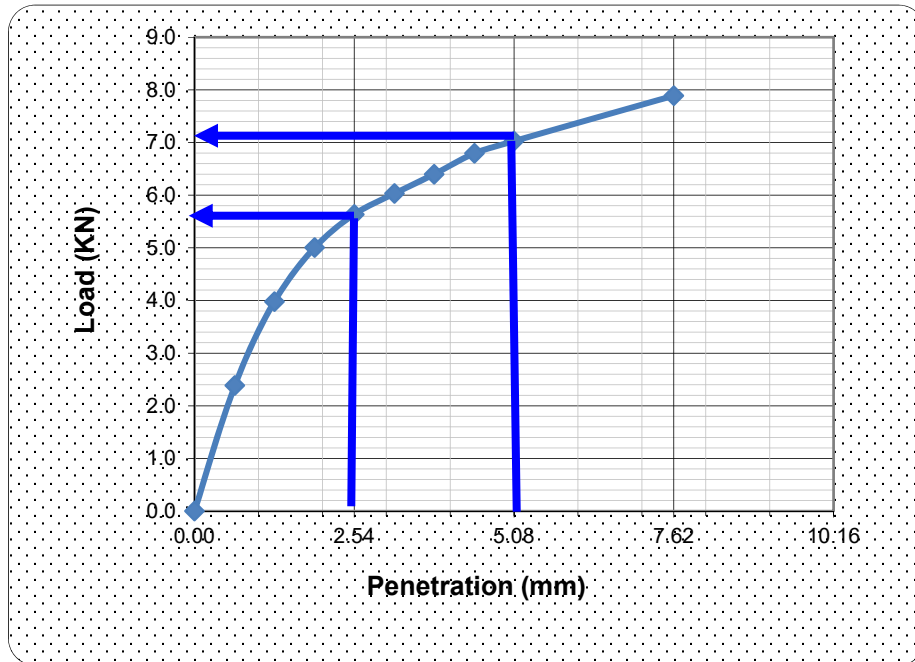

Fig 3.5: Typical Load Vs Penetration graph for CBR (1-point) test (sample no 13)

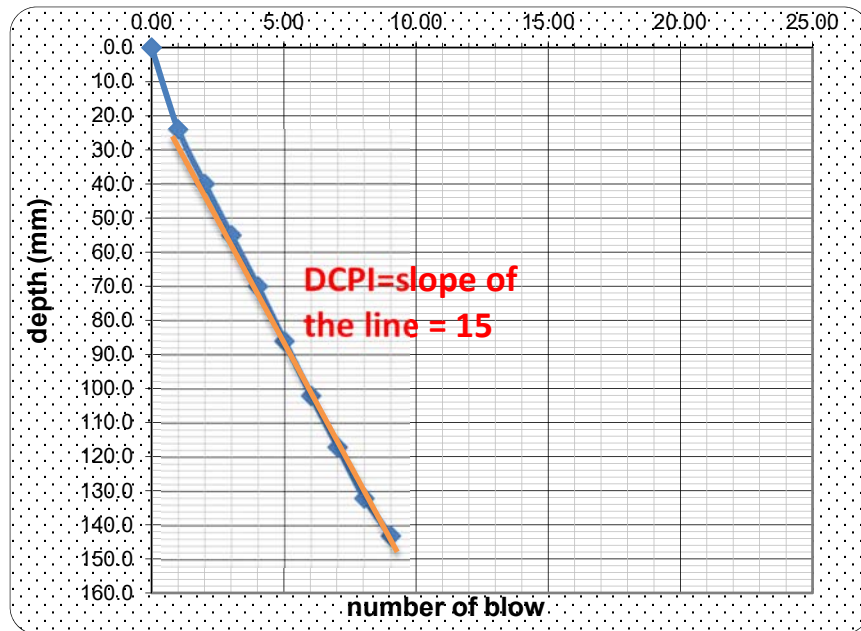

Fig 3.6: Typical Penetration depth Vs number of blows graph for DCP test (sample no 13)

3.4 Summary of Test Results

Summary of test results are tabulated in the following tables.

Table 3.1: Soil Index test Results

Site designation	sample number	Specific gravity	Liquid Limit (%)	Plastic limit (%)	Plasticity index	MDD(gm/cm ³)	OMC(%)	Grain Size Analysis				Soil Classification
								>2mm	2-0.075mm	0.075-0.002mm	<0.002mm	
Semen Mazegagia	1	2.64	58	31	27	1.52	23.50	0.49	8.51	45.67	45.33	A-7-5
Semen Mazegagia	2	2.64	63	34	29	1.53	24.64	0.76	7.12	39.97	52.15	A-7-5
Semen Mazegagia	3	2.60	66	35	31	1.51	26.73	0.84	8.24	41.06	49.86	A-7-5
Semen Mazegagia	4	2.55	59	36	23	1.53	26.50	0.91	7.62	45.60	45.87	A-7-5
Semen Mazegagia	5	2.59	61	35	26	1.54	23.03	0.37	5.60	44.48	49.55	A-7-5
Semen Mazegagia	6	2.64	63	36	27	1.58	25.80	0.81	8.60	41.24	49.35	A-7-5
Semen Mazegagia	7	2.61	61	33	28	1.59	22.90	0.53	10.19	39.08	50.20	A-7-5
Semen Mazegagia	8	2.57	60	33	27	1.46	24.72	0.74	9.31	40.97	48.98	A-7-5
Semen Mazegagia	9	2.58	60	32	28	1.55	25.00	0.61	6.39	40.19	52.81	A-7-5
Asco	11	2.60	51	35	16	1.53	19.80	2.65	9.55	41.15	46.66	A-7-5
Asco	12	2.58	54	29	25	1.63	21.00	1.46	11.48	39.86	47.21	A-7-6
Asco	13	2.58	48	28	20	1.57	25.00	0.79	15.79	37.25	46.17	A-7-6
Asco	14	2.61	48	29	19	1.57	25.00	0.74	15.34	37.00	46.92	A-7-6

SOAKED CBR VALUE DETERMINATION FROM LABORATORY DCP TEST FOR ADDIS ABABA RED CLAY SOIL

Site designation	sample number	Specific gravity	Liquid Limit (%)	Plastic limit (%)	Plasticity index	MDD(gm/cm ³)	OMC(%)	Grain Size Analysis				Soil Classification
								>2mm	2-0.075mm	0.075-0.002mm	<0.002mm	
Asco	17	2.58	47	27	20	1.62	21.50	1.37	11.70	39.39	47.54	A-7-6
Asco	18	2.60	52	30	22	1.58	21.43	0.45	14.07	37.17	48.31	A-7-5
Gulle Park	19	2.60	52	31	21	1.63	23.40	0.67	7.23	43.24	48.87	A-7-5
Gulle Park	21	2.62	49	31	18	1.64	22.20	0.32	8.56	43.58	47.55	A-7-5
Gulle Park	22	2.63	60	33	27	1.61	24.50	0.34	5.90	46.11	47.64	A-7-5
Shiromeda	29	2.63	62	37	25	1.63	27.40	0.12	3.13	40.40	56.36	A-7-5
Shiromeda	30	2.60	60	33	27	1.53	28.50	0.12	3.29	35.32	61.28	A-7-5
Shiromeda	33	2.64	65	38	27	1.58	29.00	0.11	3.31	38.58	58.01	A-7-5

SOAKED CBR VALUE DETERMINATION FROM LABORATORY DCP TEST FOR ADDIS ABABA RED CLAY SOIL

Table 3.2: Laboratory CBR and Laboratory DCP test Results

Site designation	sample number	CBR						DCP					
		Un-soaked			Soaked			Un-soaked			Soaked		
		CBR (%)	Moisture Content (%)	Dry Density (gm/cm ³)	CBR (%)	Moisture Content (%)	Dry Density (gm/cm ³)	DCPI	Moisture Content (%)	Dry Density (gm/cm ³)	DCPI	Moisture Content (%)	Dry Density (gm/cm ³)
Semen Mazegajia	1	89.14	23.71	1.51	10.13	32.40	1.51	5.00	23.71	1.52	25	32.86	1.52
Semen Mazegajia	2	79.73	24.25	1.52	10.80	28.98	1.51	5.00	24.16	1.52	14	28.50	1.52
Semen Mazegajia	3	90.39	26.75	1.51	9.02	35.63	1.49	6.00	26.75	1.51	22	35.17	1.49
Semen Mazegajia	4	77.87	26.74	1.53	11.52	32.85	1.53	6.00	26.54	1.51	18	33.63	1.51
Semen Mazegajia	5	89.14	23.79	1.54	9.02	30.11	1.55	6.00	23.58	1.55	29	30.07	1.56
Semen Mazegajia	6	82.38	25.59	1.58	8.14	31.70	1.55	6.00	25.59	1.58	22	34.69	1.56
Semen Mazegajia	7	75.15	22.84	1.60	5.65	34.28	1.59	5.00	22.97	1.61	26	34.38	1.60
Semen Mazegajia	8	77.62	24.25	1.46	4.98	37.71	1.44	6.00	24.25	1.44	40	36.33	1.43
Semen Mazegajia	9	74.62	24.94	1.55	7.64	37.94	1.53	6.00	24.68	1.55	22	37.24	1.53
Asco	11	78.88	19.63	1.53	4.48	31.38	1.52	5.00	20.17	1.53	41	32.07	1.52
Asco	12	53.08	21.16	1.62	16.03	25.60	1.61	5.00	21.16	1.63	15	28.97	1.60
Asco	13	42.57	24.97	1.57	16.03	27.80	1.58	15.00	24.97	1.57	21	30.84	1.58
Asco	14	40.53	24.67	1.56	15.78	29.60	1.54	15.00	24.47	1.58	22	26.72	1.60
Asco	17	62.60	21.45	1.62	15.52	25.70	1.63	7.00	21.22	1.61	14	27.89	1.59

SOAKED CBR VALUE DETERMINATION FROM LABORATORY DCP TEST FOR ADDIS ABABA RED CLAY SOIL

Site designation	sample number	CBR						DCP					
		Un-soaked			Soaked			Un-soaked			Soaked		
		CBR (%)	Moisture Content (%)	Dry Density (gm/cm ³)	CBR (%)	Moisture Content (%)	Dry Density (gm/cm ³)	DCPI	Moisture Content (%)	Dry Density (gm/cm ³)	DCPI	Moisture Content (%)	Dry Density (gm/cm ³)
	18	75.12	21.67	1.58	6.51	27.29	1.59	5.00	21.67	1.57	37	28.63	1.57
Gulelle Park	19	85.39	23.75	1.62	12.02	28.05	1.62	6.00	23.75	1.63	15	27.18	1.64
Gulelle Park	21	60.10	22.52	1.63	17.53	25.65	1.63	6.00	22.36	1.64	11	23.60	1.63
Gulelle Park	22	56.09	24.50	1.63	11.79	26.6	1.61	10.00	24.04	1.63	13	28.10	1.60
Shiromeda	29	76.37	27.70	1.63	12.46	31.13	1.63	7.00	27.70	1.63	16	34.67	1.61
Shiromeda	30	55.34	28.31	1.52	14.27	33.64	1.51	12.00	28.44	1.53	14	30.68	1.53
Shiromeda	33	65.11	29.64	1.58	13.03	33.33	1.58	7.00	29.73	1.57	21	33.51	1.56

3.5 Discussion of Test Results

When the soil classification is made according to AASHTO soil classification system, all of the soil samples are classified as A-7 and fifteen out of twenty-one samples are A-7-5 and the rest are A-7-6.

LL of the soil samples ranges from 43 to 66, PL from 27 to 40, and PI from 15 to 31.

The Specific gravity of the soil samples ranges from 2.55 to 2.65,

The following table compares the soil index test results of this thesis with the previous test results made on Addis Ababa red clay soils.

Table 3.3 comparison of test results

Researches	Year	Site	LL (%)	PI (%)	Gs
Samuel Tadesse [17]	1989	Kolfe and Semen Mazegajia	59 - 75	15 – 47	2.66 - 2.77
Tesfay Neare [21]	2004	Different places in AA where red clay exists	47.3 - 82	23.5 – 55.5	N/A
Merihun Lukas[14]	2010	Kolfe and Semen Mazegajia	61 - 72	34 – 39	2.71 - 2.73
Anteneh Getachew[3]	2012	Different places in AA where red clay exists	44 - 66	14 - 30	2.61 - 2.9
Ermias Geneye[9]	2014	Different places in AA where red clay exists	54-72	22-38	2.67 – 2.76
Current research	2015	Shiromeda, Semen Mazegajia, Gulelle Park and Asco	43-66	15-31	2.55-2.65

The un-soaked CBR test results range from 40 to 90 and Soaked CBR results range from 4.5 mm/blow to 17.5mm/blow.

DCP test results, which were conducted on CBR molds, confirmed that the penetration depth is not too short to conduct DCP tests on CBR molds. Especially for un-soaked samples a lot of blows were required to penetrate the 120mm mold depth; for example 25 blows were recorded to penetrate on an un-soaked sample obtained from Semen Mazegajia area. Soaked DCP test results ranges from 11mm/blow to 41mm/blow and un-soaked DCP test results ranges from 5mm/blow to 15mm/blow.

4. Data Analysis

4.1 General

As it was aforementioned, the main objective of this thesis is to check the relationship between CBR and DCP test results and to indirectly determine soaked CBR values from DCP tests conducted on re-molded samples. In addition, the relationship between DCP, CBR, OMC, MDD, and PI were checked. Accordingly, the data analysis was made using regression analysis to exploit the relationship between two or more variables so that we can get information about one of them by having the values of others. During the data analysis different kinds of models such as linear, logarithmic, and exponential models were used. However prior to carrying out the regression analysis, scatter diagrams were developed to visually assess the form of the relationship.

4.2 Scatter Diagram

A Scatter diagram is a useful tool to visually observe the relation between two variables by inspecting the pattern of points placed in the diagram. If there is a relationship between two variables, the points in the diagram randomly scattered around a straight line or some form of curve. If there is no relationship, the points are spatially dispersed. The following selected Scatter diagrams are presented to visually observe the relationship between CBR, DCP, and different other soil index parameters.

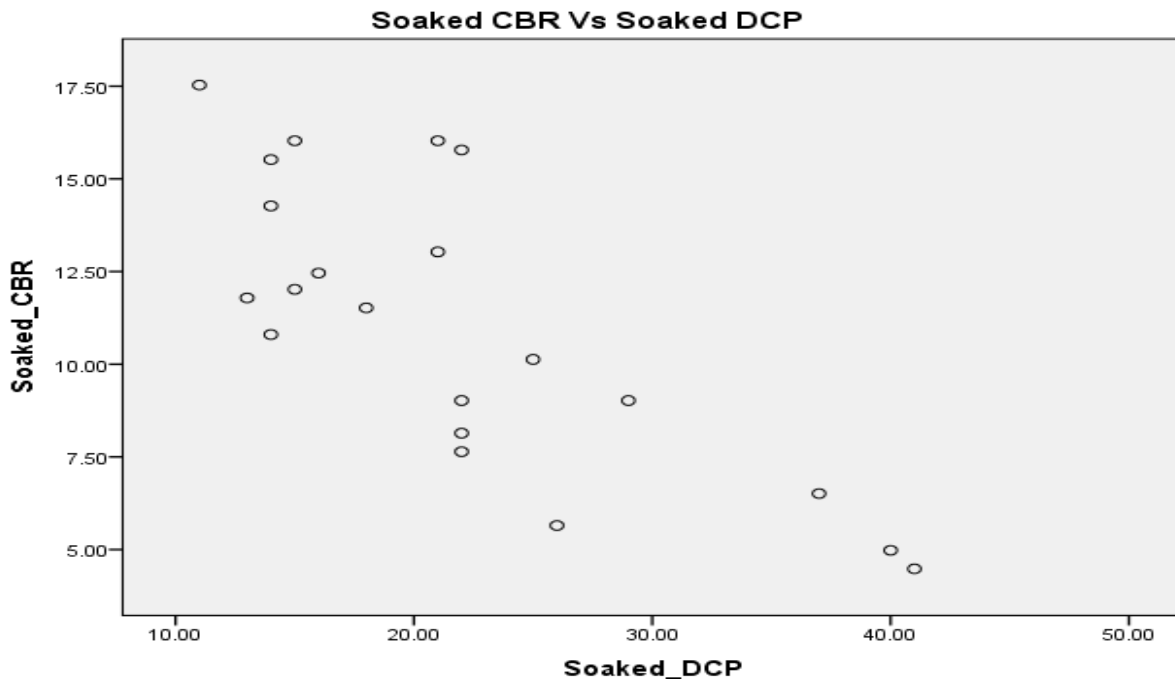

Fig 4.1 Scatter diagram for Soaked CBR VS Soaked DCP

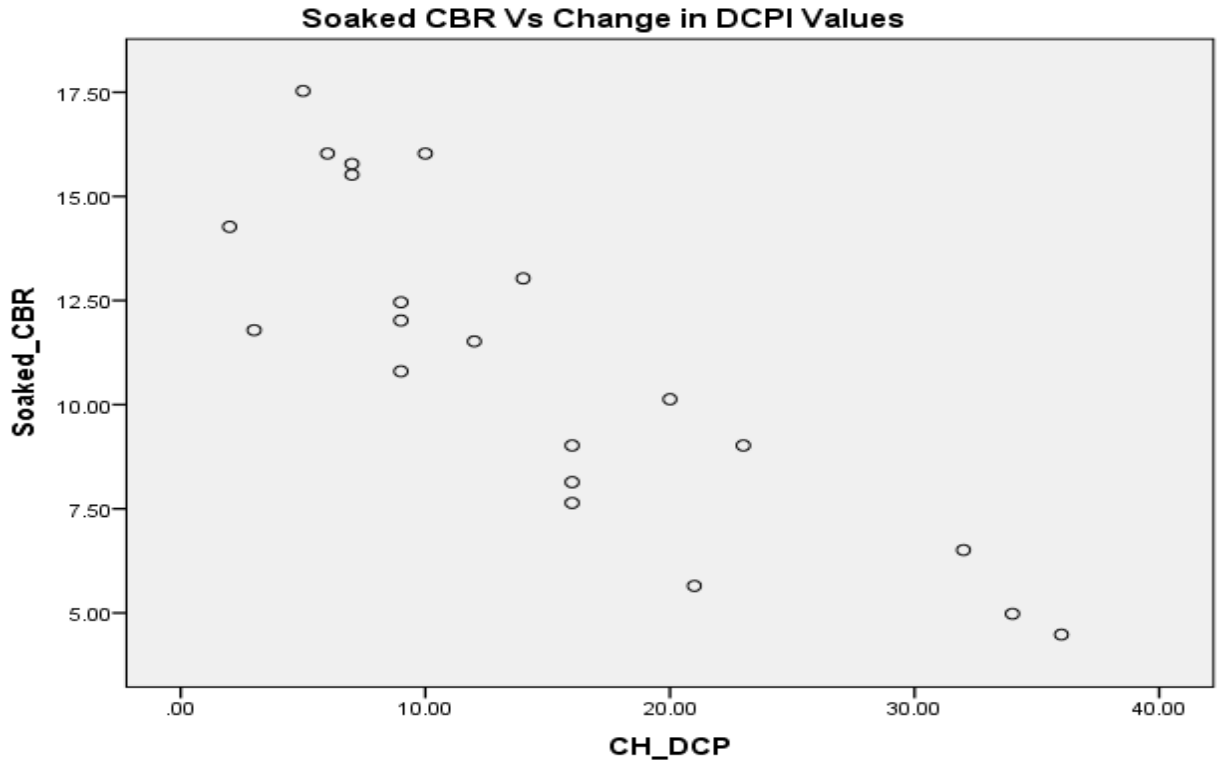

Fig 4.2 Scatter Diagram Soaked CBR vs CH_DCP, (where, CH_DCP= Soaked DCP - Un soaked DCP)

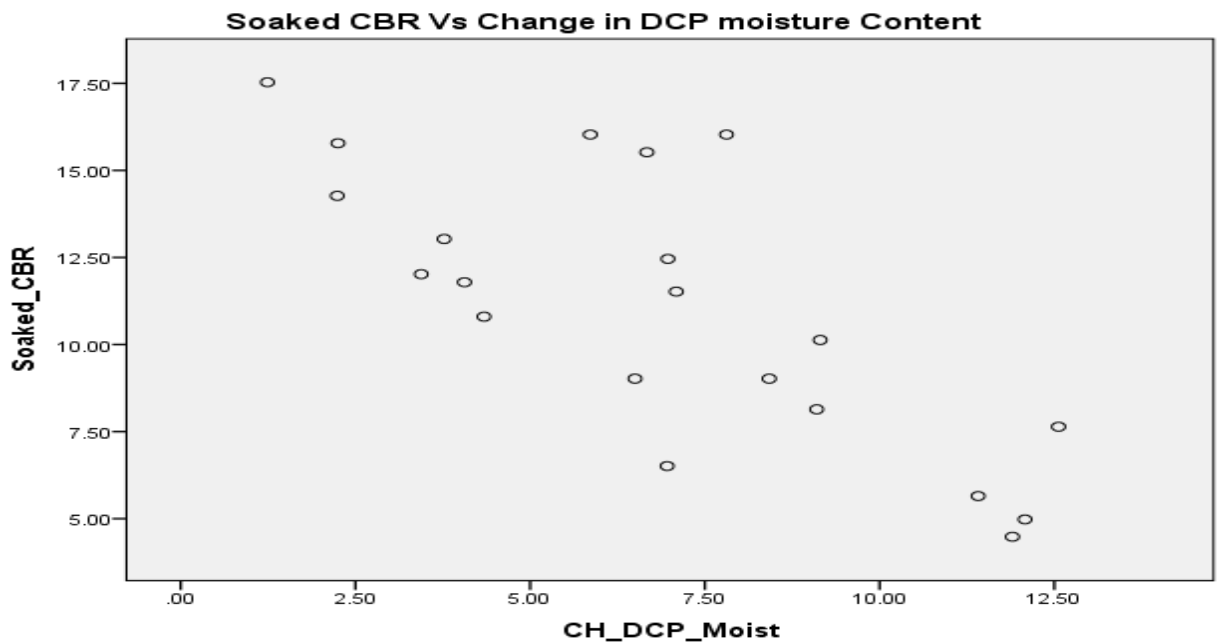

Fig 4.3 Scatter Diagram Soaked CBR vs CH_DCP_Moist (where, CH_DCP_Moist = the difference between the moisture content of the remolded sample before and after soaking the sample which is used to conduct DCP tests)

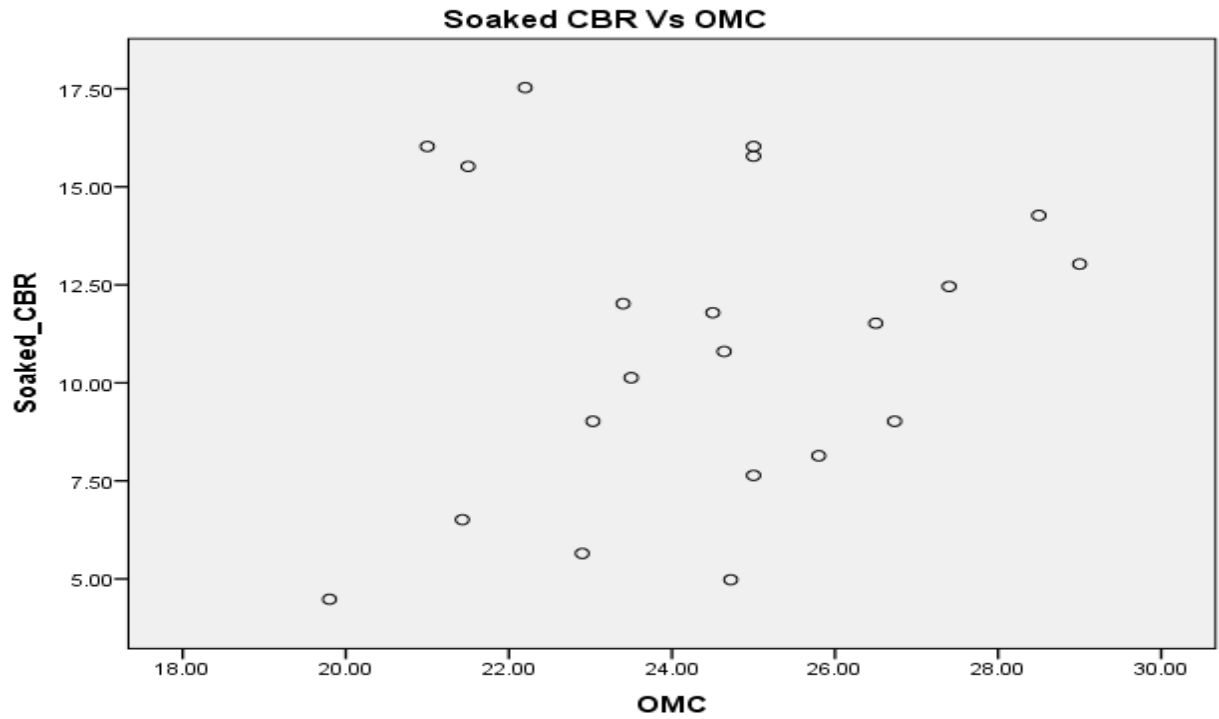

Fig 4.4 Scatter Diagram Soaked CBR vs Optimum Moisture Content

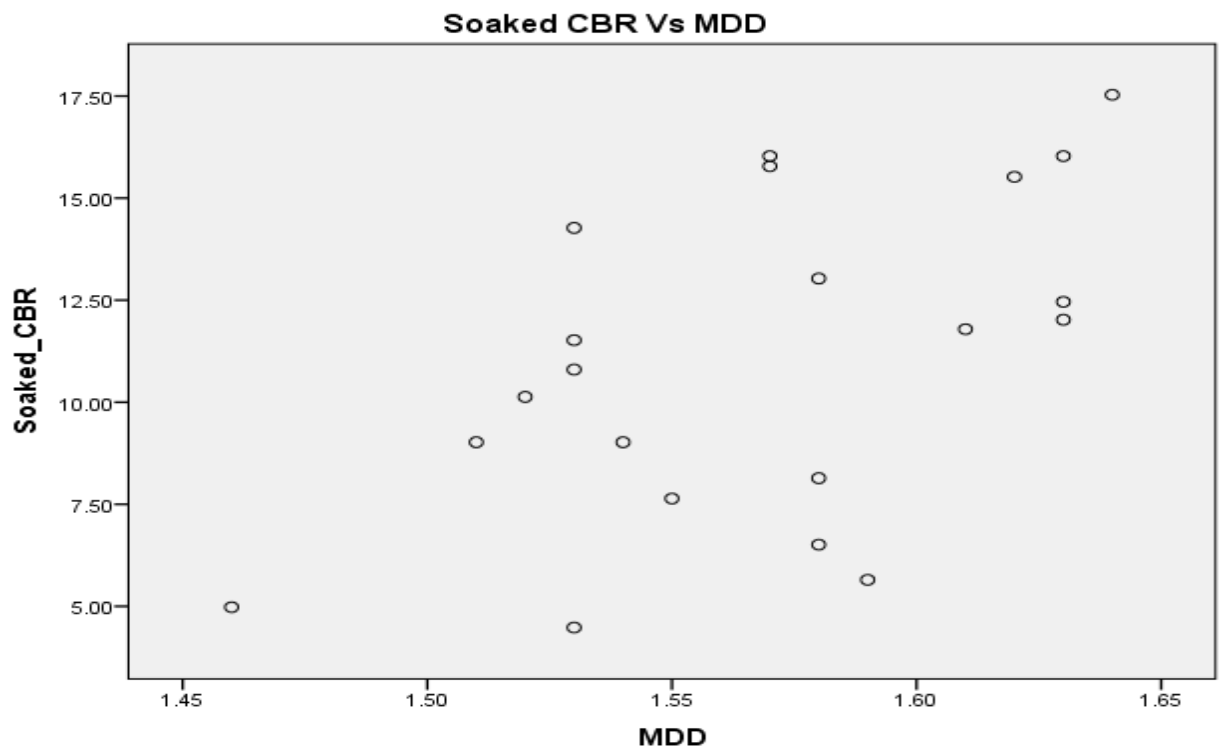

Fig 4.5 Scatter Diagram Soaked CBR vs Maximum Dry Density

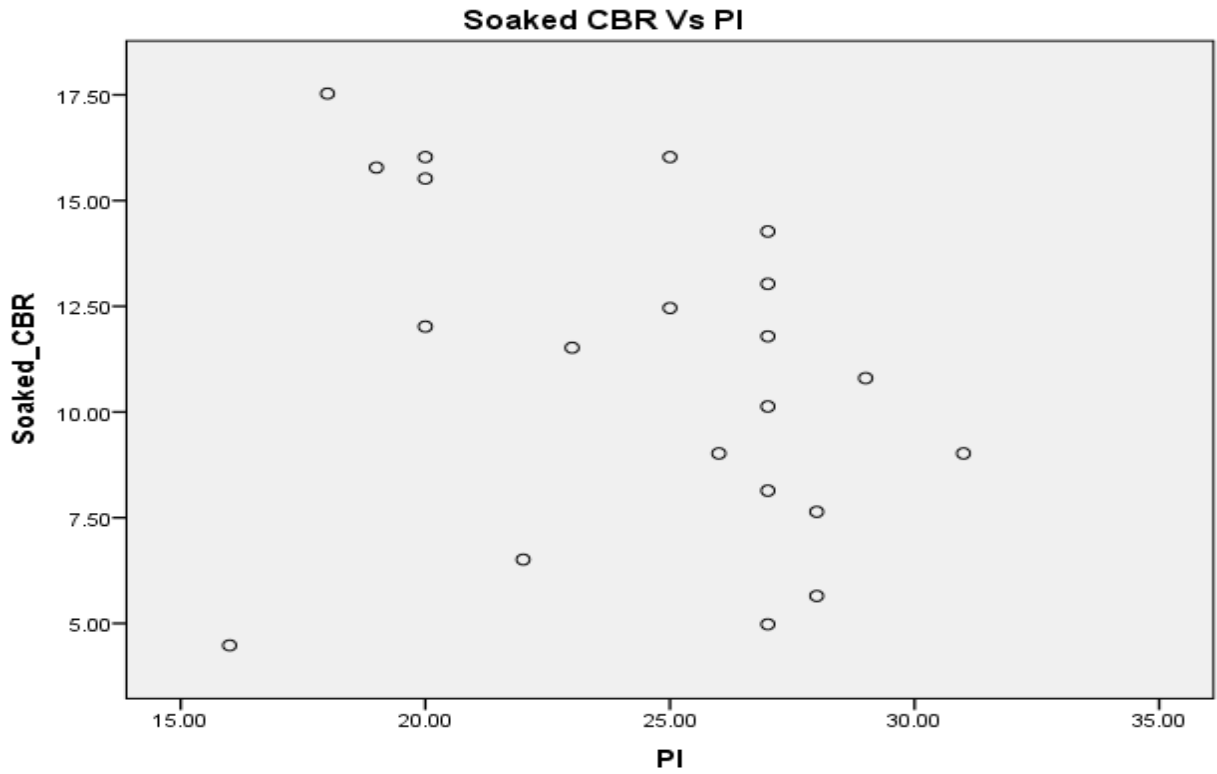

Fig 4.6 Scatter Diagram Soaked CBR vs Plastic Index

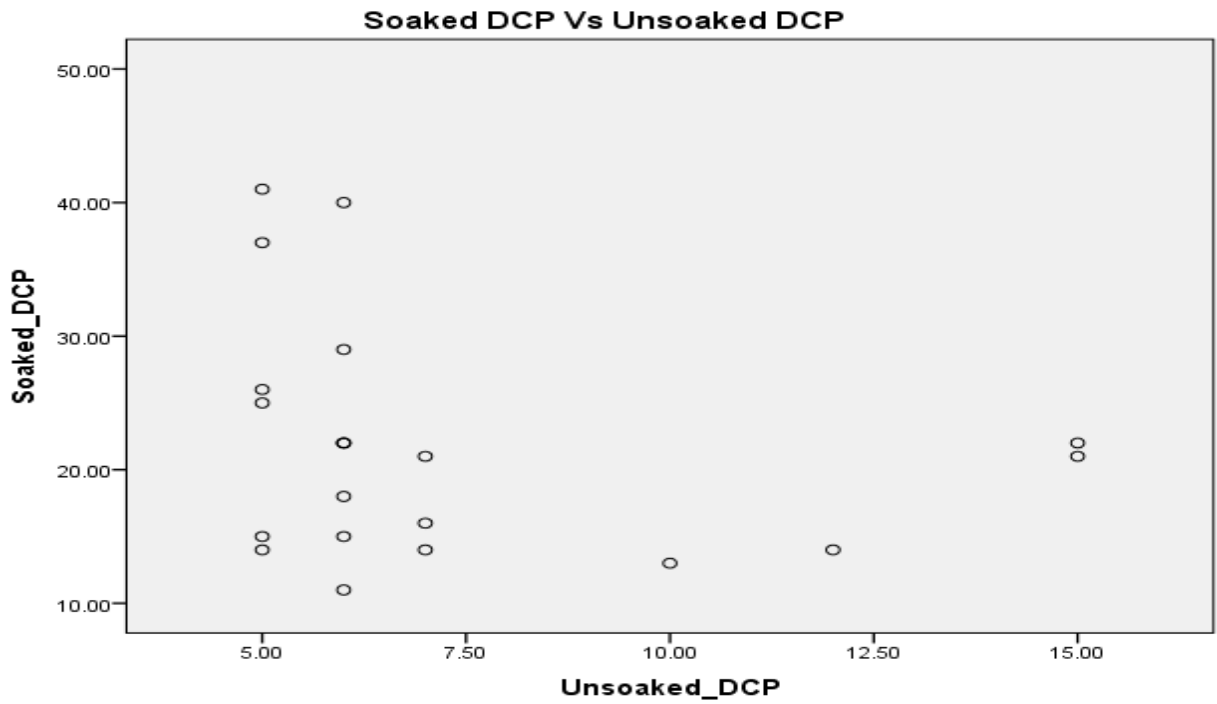

Fig 4.7 Scatter Diagram Soaked DCP vs Un-soaked DCP

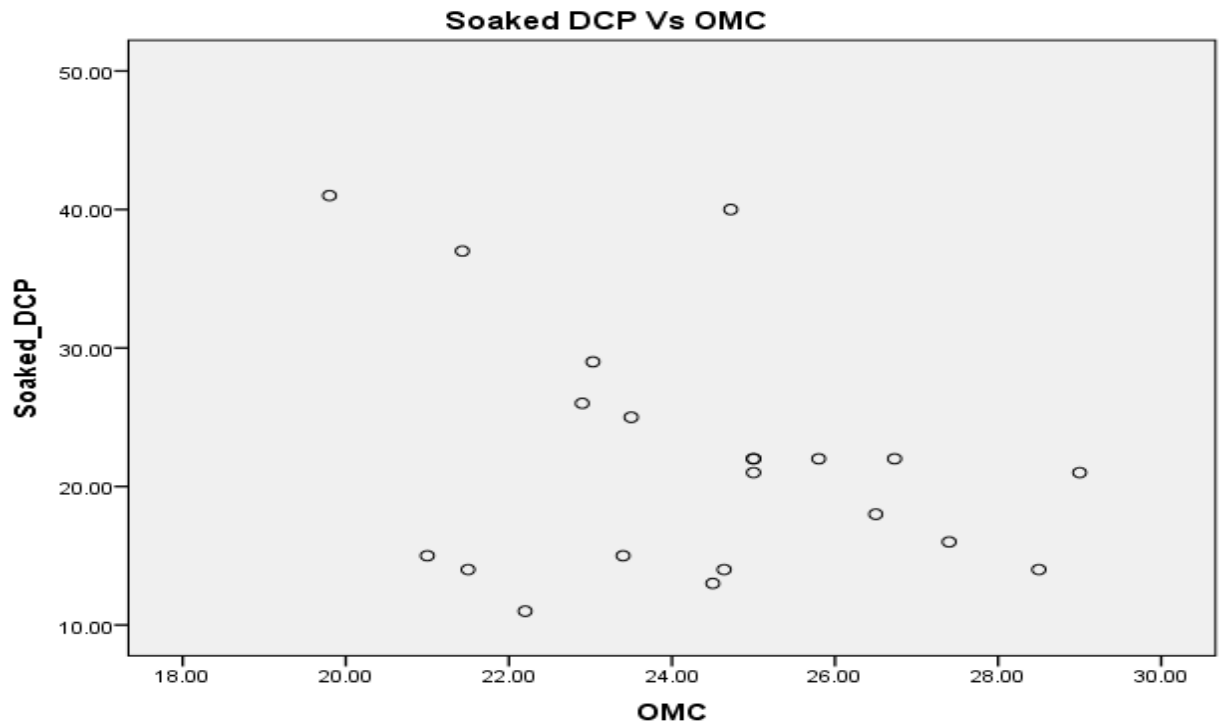

Fig 4.8 Scatter Diagram Soaked DCP vs Optimum moisture content

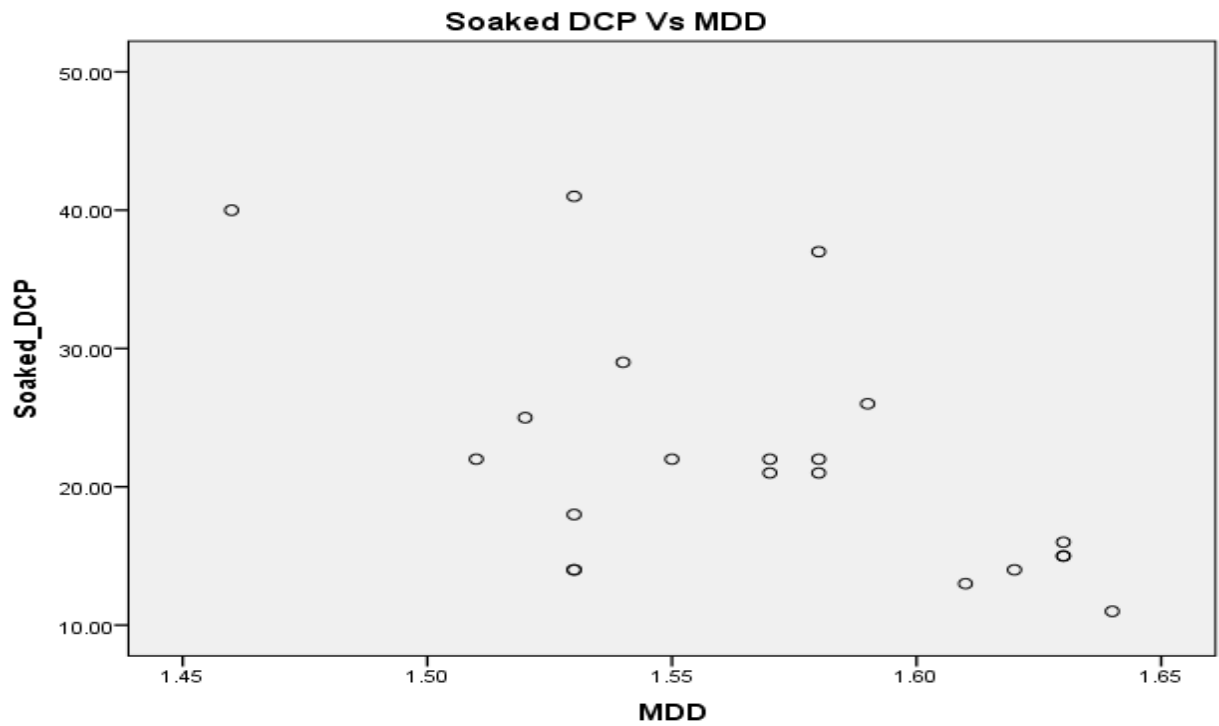

Fig 4.9 Scatter Diagram Soaked DCP vs Maximum dry density

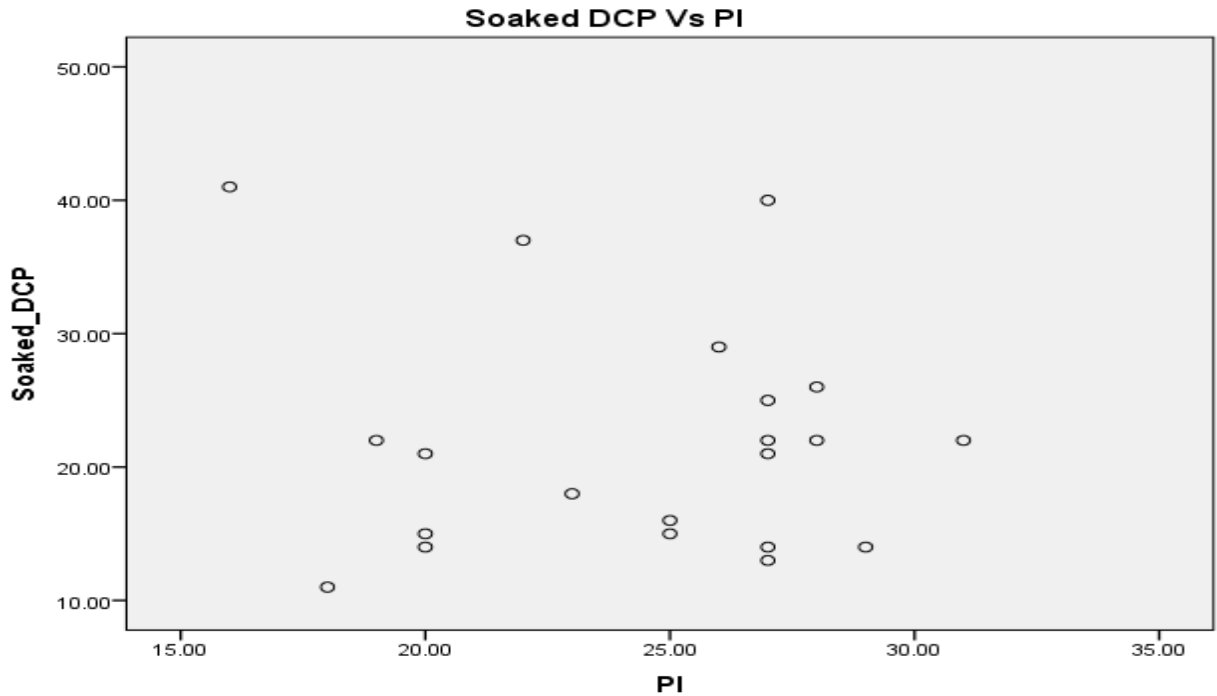

Fig 4.10 Scatter Diagram Soaked DCP vs Plastic Index

From the above scatter diagrams,

- It is clearly seen that the points of the variables randomly lie around a line for relation between Soaked CBR with Soaked DCP, Change in DCP and Change in DCP moisture content and also Soaked DCP with Change in DCP and Change in DCP moisture content.
- For the rest combinations, no relationship can be developed since the points of the variables were spatially dispersed.

4.3 Regression

Regression analysis is a statistical technique that is very useful in the field of engineering and science in modeling and investigating relationships between two or more variables. The method of regression analysis is used to develop a line or curve which provides the best fit through a set of data points. This curve can be useful to identify a trend in the data, whether it is linear, logarithmic, exponential or other form.

Regression analysis divided into either simple regression or multiple regression analysis pertinent to the number of variables involved in the system. A regression model that contains more than one independent variable is called multiple regression

model. Whereas, a regression model that contains only a single independent variable is termed as simple regression model [8].

Two of the factors among the factors that can be used to judge the adequacy of a regression model are the coefficient of determination and standard error of the regression. [12]

The coefficient of determination (R^2) is the ratio of the sample variation to the total sample variation. It shows how well the regression line fits the data. It ranges from zero to one. When the value is near or equal to 1 our regression line fits the data well. And it is presented in percentage.

The standard error of the regression is another factor, which is useful when interpreting the results of the regression. It measures how far the individual points are from the mean value. The smaller of this value means the data points are closely clustered around the mean value

4.4 Procedure of the Analysis

The analysis of this study was made by developing different kinds of models. Since the purpose of this thesis is to determine soaked CBR values from DCP tests, in all models Soaked CBR is presented as a dependent variable and other test variables together with the DCP values are presented as independent variables.

The comparison was made in three stages. In the first stage, the influence of one variable on the other was checked using Pearson correlation coefficient matrix for each test variable.

In the second stage depending on the information obtained in Pearson correlation coefficient matrix, those variables which have strong relationship with soaked CBR values were selected and simple regression analysis was made for each of them.

Lastly, in order to get a better coefficient of determination, multiple regression analysis was made and the best model was selected. All of the models were analyzed using the statistical software called SPSS.

The models are summarized in the following tables.

SOAKED CBR VALUE DETERMINATION FROM LABORATORY DCP TEST FOR ADDIS ABABA RED CLAY SOIL

Table 4-1 Correlation Matrix of Pearson Correlation Coefficient

	Soaked_CBR	Unsoaked_CBR	Unsoaked_DCP	Soaked_DCP	CH_DCP	CH_DCP_Moist	OMC	MDD	PI
Soaked_CBR	1.000	-.686	.530	-.779	-.850	-.767	.159	.547	-.318
Unsoaked_CBR	-.686	1.000	-.771	.348	.546	.478	-.043	-.365	.378
Unsoaked_DCP	.530	-.771	1.000	-.238	-.521	-.487	.358	.043	-.247
Soaked_DCP	-.779	.348	-.238	1.000	.953	.639	-.311	-.572	-.084
CH_DCP	-.850	.546	-.521	.953	1.000	.713	-.385	-.516	.004
CH_DCP_Moist	-.767	.478	-.487	.639	.713	1.000	-.261	-.424	.257
OMC	.159	-.043	.358	-.311	-.385	-.261	1.000	-.235	.513
MDD	.547	-.365	.043	-.572	-.516	-.424	-.235	1.000	-.374
PI	-.318	.378	-.247	-.084	.004	.257	.513	-.374	1.000

-where, CH_DCP = soaked DCP – Un-soaked DCP; and CH_DCP_Moist = the difference between the moisture content of the remolded sample, which was used for DCP test, before and after soaking.

SOAKED CBR VALUE DETERMINATION FROM LABORATORY DCP TEST FOR ADDIS ABABA RED CLAY SOIL

Table 4.2: Linear Simple Empirical Equations

Dependent Variable	Independent Variable	Equation	R²	Standard error of Regression
Soaked CBR	Soaked DCP	$S_CBR = -0.35(S_DCP) + 18.72$	60.70%	2.54
Soaked CBR	Change in DCP	$S_CBR = -0.34(CH_DCP) + 15.99$	72.20%	2.13
Soaked CBR	Change in DCP moisture content	$S_CBR = -0.89(CH_DCP_moist) + 17.16$	58.80%	2.60

Table 4.3: Logarithmic Simple Empirical Equations

Dependent Variable	Independent Variable	Equation	R²	Standard error of Regression
Soaked CBR	Soaked DCP	$\text{Log}(S_CBR) = -0.88\text{Log}(S_DCP) + 2.16$	66.40%	0.10
Soaked CBR	Change in DCP	$\text{Log}(S_CBR) = -0.42\text{Log}(CH_DCP) + 1.46$	62.90%	0.11
Soaked CBR	Change in DCP moisture content	$\text{Log}(S_CBR) = -0.46\text{Log}(CH_DCP_moist) + 1.37$	50.30%	0.13

Table 4.4: Multiple Linear Empirical Equations

Dependent Variable	Independent Variable	Equation	R²	Standard error of Regression
Soaked CBR	Soaked DCP, Change in DCP	$S_CBR = -0.46(CH_DCP) + 0.15(S_DCP) + 14.54$	73.30%	2.15
Soaked CBR	Soaked DCP, Change in DCP moisture content	$S_CBR = -0.53(CH_DCP_moist) - 0.22(S_DCP) + 19.49$	72.90%	2.16

SOAKED CBR VALUE DETERMINATION FROM LABORATORY DCP TEST FOR ADDIS ABABA RED CLAY SOIL

Table 4.5: Multiple Logarithmic Empirical Equations

Dependent Variable	Independent Variable	Equation	R²	Standard error of Regression
Soaked CBR	Soaked DCP, Change in DCP	$\text{Log}(S_CBR) = -0.55 \text{Log}(S_DCP) - 0.19 \text{Log}(CH_DCP) + 1.93$	70.0%	0.10
Soaked CBR	Soaked DCP, Change in DCP moisture content	$\text{Log}(S_CBR) = -0.66 \text{Log}(S_DCP) - 0.21 \text{Log}(CH_DCP_moist) + 2.03$	72.60%	0.097

5. Discussion of the Statistical Analysis

From the above scatter diagrams and regression analyses, strong relationships were obtained between Soaked CBR, Soaked DCP, Change in DCP and Change in DCP moisture contents. The values of CBR and DCP were majorly affected by the change in moisture content, this is expected because finer soils such as red clay soils are influenced by the change in moisture content.

Soaked CBR is negatively correlated with soaked DCP, Change in DCP and Change in DCP moisture. Obviously, the higher CBR values shows the stronger material which demands more blows for DCP, which in return indicates lesser DCP values. Furthermore, for finer soils such as red clay soils the increase in moisture content decrease the strength, hence it increases the Change in DCP.

Among the developed models, the highest coefficient of determinations were obtained from multiple linear empirical equations (table 4.4) and they are presented as follows:

$$S_CBR = -0.46(CH_DCP) + 0.15(S_DCP) + 14.54 \dots \dots \dots \text{Equation-1}$$

$$R^2 = 73.3\% \quad SE = 2.15$$

$$S_CBR = -0.53(CH_DCP_moist) - 0.22(S_DCP) + 19.49 \dots \dots \dots \text{Equation-2}$$

$$R^2 = 72.9\% \quad SE = 2.16$$

Equation-1 has a higher Coefficient of determination than Equation-2. However, it demands a longer test procedure than Equation-2. For Equation-1, Un-soaked DCP tests should be conducted to obtain the change in DCP variable. Whereas, Equation-2 requires only to conduct Soaked DCP tests. The change in DCP moisture content can be computed by recording the moisture content before and after soaking the sample while conducting the Soaked DCP tests.

Hence, although Equation-2 has a slightly lesser coefficient of determination than Equation-1, for the sake of simplicity of test procedure, Equation-2, with $R^2 = 72.9\%$ and standard error of regression = 2.16, is recommended as the best Empirical Equation of this thesis.

Validation of the developed Equation

The empirical equations developed here could not be compared with the previous empirical equations since none of them correlates soaked CBR with laboratory DCP.

Hence, to validate the proposed empirical equation, three additional samples were randomly taken from three sites. Like the other twenty one samples, all the required tests were performed. With these values in hand, the soaked CBR values obtained with the equation and the soaked CBR values obtained from the laboratory were compared. The comparison is presented in table 5.1.

Sample Number	Site Designation	Soaked_DCP	CH_DCP_moist	Peredicted Soaked CBR " $C = -0.53 \times b - 0.22 \times a + 19.49$ " (from the developed empirical equation)	Laboratory Soaked_CBR	Variation (%)
		"a"	"b"	"c"	"d"	"(c-d)/d"
10	Semen Mazegajja	26	7.88	9.6	8.64	-11.11%
15	Asco	23	2.36	13.18	15.78	16.48%
34	Shiromeda	19	7.51	11.33	10.8	-4.91%

Table 5.1: validation of the developed Empirical Equation

6. Conclusion and Recommendation

6.1 Conclusion

The primary objective of this thesis was to determine soaked CBR values by conducting DCP tests in laboratory since DCP tests are relative cheap, fast and easy to use. Accordingly, results of the regression analysis of this study show that satisfactory relationships of soaked CBR with soaked DCP, change in DCP and change in DCP moisture content may be established. The following empirical equation was developed with 72.9% coefficient of determination and 2.16 standard error of regression based on 21 samples;

$S_CBR = -0.53(CH_DCP_moist) - 0.22(S_DCP) + 19.49$; where; S_CBR and S_DCP are to mean that Soaked CBR and Soaked DCP respectively, and CH_DCP_moist is the difference between the water contents of the sample before & after soaking the remolded sample for DCP tests.

Hence, using the developed empirical equation, we can indirectly determine Soaked CBR values from DCP tests conducted in laboratory.

Furthermore, the developed empirical equation can be used to determine CBR values at any percentage of moisture content as far as DCP tests are also conducted at the same moisture content.

6.2 Recommendation

- Further studies for other soil types have to be carried out to check the applicability of the equations.

References

- [1] AFCAP Workshop Summaries on Rural Infrastructure and Transport Services (4th-8th Mach 2013), Africa Transportation Technology Transfer Conference, Gaborone, Botswana,
- [2] American Association of State Highway & Transportation Officials (2001), 'Standard specification for transportation materials & methods of sampling & testing', 444 North Capitol street N.W., Suite 249, Washington, D.C.
- [3] Anteneh Getachew (2012), "Correlating Dynamic Cone Penetration Index with Undrained Shear Strength for Clayey Soils" A Thesis Presented to school of Graduate studies, Addis Ababa University.
- [4] Ashworth, R. (1972) 'Highway Engineering', London, Heinemann Educational Book.
- [5] Colin Jones (May 2004), 'Dynamic Cone Penetrometer tests and analysis', Technical Information Note, Copy right TRL Limited.
- [6] Croney, D. & Croney, P. (1991) 'The Design & Performance of road pavements', London, Mc-Graw Hill Book Company.
- [7] Design Manual for Low Volume Sealed Roads Using the DCP Design Method (September 2013), Republic of Malawi, Ministry of Transport and Public Works.
- [8] Douglas C. Montgomery, and George C. Runger (2003), 'Applied Statistics & probability for Engineers'
- [9] Ermias Geneye (2014), 'Predicting the value of CBR from DCP for Addis Ababa red Clay soil ' A thesis presented to school of graduate studies, Addis Ababa University'.
- [10] Farshad Amini (2003), 'Potential Applications of Dynamic & static cone penetrometers in MDOT pavement design & construction.' Jackson state university, Jackson.
- [11] Harrison, J.A. (1986), 'Correlation of CBR & Dynamic Cone Penetrometer strength measurement of soil' Australian Road Research.
- [12] Jay L. Devore (2010), 'Probability and Statistics for Engineering and Science', California polytechnic state university, San Luis Obispo.
- [13] Kleyen, E.G. (1975), 'The use of dynamic cone penetrometer (DCP)' Report 2/74, Pretoria: Transval roads department.

- [14] Merihun Lukas (2004), "A Study on the Effect of Remolding on the Mechanical Behavior of Addis Ababa Red Clay Soils," a Thesis presented to School of Graduate Studies, Addis Ababa University.
- [15] P Paige-Green and L Du Plessis (September 2009), 'The use and interpretation of the dynamic cone penetrometer test', Pretoria.
- [16] 'Pavement Design Manual, vol-1' (2002), Ethiopian Roads Authority.
- [17] Samule Tadesse (1989), "Investigation into some of the Engineering properties of Addis Ababa Red Clay Soil," A Thesis presented to School of Graduate Studies, Addis Ababa University.
- [18] Scala, A.J. (1956) ' Simple methods of flexible pavement design using cone penetrometers' in proceedings of 2nd Australia New Zealand conference on soil mechanics & foundation Engineering, New Zealand.
- [19] Shin Wu, Shad Sargand (2007) 'Use of Dynamic Cone Penetrometer in Subgrade & base acceptance'
- [20] Talal Al-Refeai and A. Al-Suhaibani (Jan 1996), 'Prediction of CBR using Dynamic Cone Penetrometer' King Saud University.
- [21] Tesfay Neare (2004), "Determination of Parameters for the Tangent Modulus Approach," A Thesis presented to School of Graduate Studies, Addis Ababa University.
- [22] X. Luo, R. Salgado and A. Altschaeffl (September 1998), 'Dynamic Cone Penetration Test to Assess the Mechanical Properties of the Subgrade Soil'.
- [23] Yitagesu Desalegn, (2012) 'Developing correlation between DCP & CBR for locally used subgrade material' A Thesis presented to School of Graduate Studies, Addis Ababa University.

APPENDICES

APPENDIX A – SPECIFIC GRAVITY TEST RESULTS

Sample No.-1

Trial	1	2
Mass of Pycnometer	22.78	23.61
Mass of Pycnometer + Soil	32.78	33.74
Mass of Pycnometer + Water	73.88	75.05
Mass of Pycnometer + Soil + Water	80.08	81.35
Specific Gravity	2.63	2.64
Average	2.64	

Sample No.-2

Trial	1	2
Mass of Pycnometer	24.43	22.78
Mass of Pycnometer + Soil	34.43	32.78
Mass of Pycnometer + Water	75.47	73.88
Mass of Pycnometer + Soil + Water	81.70	80.08
Specific Gravity	2.65	2.63
Average	2.64	

Sample No.-3

Trial	1	2
Mass of Pycnometer	22.78	24.43
Mass of Pycnometer + Soil	32.78	34.43
Mass of Pycnometer + Water	73.88	75.47
Mass of Pycnometer + Soil + Water	80.02	81.63
Specific Gravity	2.59	2.60
Average	2.60	

SOAKED CBR VALUE DETERMINATION FROM LABORATORY DCP TEST FOR ADDIS ABABA RED CLAY SOIL

Sample No.-4

Trial	1	2
Mass of Pycnometer	23.61	22.78
Mass of Pycnometer + Soil	33.74	32.78
Mass of Pycnometer + Water	75.05	73.88
Mass of Pycnometer + Soil + Water	81.22	79.96
Specific Gravity	2.56	2.55
Average	2.55	

Sample No.-5

Trial	1	2
Mass of Pycnometer	22.78	23.61
Mass of Pycnometer + Soil	32.78	33.74
Mass of Pycnometer + Water	73.88	75.05
Mass of Pycnometer + Soil + Water	80.03	81.26
Specific Gravity	2.60	2.58
Average	2.59	

Sample No.-6

Trial	1	2
Mass of Pycnometer	24.43	22.78
Mass of Pycnometer + Soil	34.43	32.78
Mass of Pycnometer + Water	75.76	73.88
Mass of Pycnometer + Soil + Water	81.95	80.11
Specific Gravity	2.625	2.653
Average	2.64	

Sample No.-7

Trial	1	2
Mass of Pycnometer	24.43	22.78
Mass of Pycnometer + Soil	34.43	32.78
Mass of Pycnometer + Water	75.47	73.88
Mass of Pycnometer + Soil + Water	81.64	80.06
Specific Gravity	2.61	2.62
Average	2.61	

Sample No.-8

Trial	1	2
Mass of Pycnometer	24.72	22.78
Mass of Pycnometer + Soil	34.72	32.78
Mass of Pycnometer + Water	75.76	73.88
Mass of Pycnometer + Soil + Water	81.87	80.00
Specific Gravity	2.57	2.58
Average	2.57	

Sample No.-9

Trial	1	2
Mass of Pycnometer	23.61	22.78
Mass of Pycnometer + Soil	33.74	32.78
Mass of Pycnometer + Water	75.05	73.88
Mass of Pycnometer + Soil + Water	81.26	80.00
Specific Gravity	2.58	2.58
Average	2.58	

SOAKED CBR VALUE DETERMINATION FROM LABORATORY DCP TEST FOR ADDIS ABABA RED CLAY SOIL

Sample No.-
10

Trial	1	2
Mass of Pycnometer	23.61	22.78
Mass of Pycnometer + Soil	33.74	32.78
Mass of Pycnometer + Water	75.05	73.88
Mass of Pycnometer + Soil + Water	81.33	80.06
Specific Gravity	2.63	2.62
Average	2.62	

Sample No.-
11

Trial	1	2
Mass of Pycnometer	24.43	22.78
Mass of Pycnometer + Soil	34.43	32.78
Mass of Pycnometer + Water	75.47	73.88
Mass of Pycnometer + Soil + Water	81.62	80.05
Specific Gravity	2.60	2.61
Average	2.60	

Sample No.-
12

Trial	1	2
Mass of Pycnometer	22.78	23.61
Mass of Pycnometer + Soil	32.78	33.74
Mass of Pycnometer + Water	73.88	75.05
Mass of Pycnometer + Soil + Water	80.00	81.27
Specific Gravity	2.58	2.59
Average	2.58	

Sample No.-
13

Trial	1	2
Mass of Pycnometer	24.43	22.78
Mass of Pycnometer + Soil	34.43	32.78
Mass of Pycnometer + Water	75.76	73.88
Mass of Pycnometer + Soil + Water	81.89	79.99
Specific Gravity	2.58	2.57
Average	2.58	

Sample No.-
14

Trial	1	2
Mass of Pycnometer	22.78	23.61
Mass of Pycnometer + Soil	32.78	33.74
Mass of Pycnometer + Water	73.88	75.05
Mass of Pycnometer + Soil + Water	80.05	81.29
Specific Gravity	2.61	2.60
Average	2.61	

Sample No.-
15

Trial	1	2
Mass of Pycnometer	23.61	22.78
Mass of Pycnometer + Soil	33.74	32.78
Mass of Pycnometer + Water	75.05	73.88
Mass of Pycnometer + Soil + Water	81.27	80.04
Specific Gravity	2.59	2.60
Average	2.60	

Sample No.-
17

Trial	1	2
Mass of Pycnometer	22.78	24.43
Mass of Pycnometer + Soil	32.78	34.43
Mass of Pycnometer + Water	73.88	75.47
Mass of Pycnometer + Soil + Water	80.02	81.58
Specific Gravity	2.59	2.57
Average	2.58	

Sample No.-
18

Trial	1	2
Mass of Pycnometer	23.61	22.78
Mass of Pycnometer + Soil	33.74	32.78
Mass of Pycnometer + Water	75.05	73.88
Mass of Pycnometer + Soil + Water	81.28	80.03
Specific Gravity	2.60	2.60
Average	2.60	

Sample No.-
19

Trial	1	2
Mass of Pycnometer	22.78	23.61
Mass of Pycnometer + Soil	32.78	33.74
Mass of Pycnometer + Water	73.88	75.05
Mass of Pycnometer + Soil + Water	80.02	81.29
Specific Gravity	2.59	2.60
Average	2.60	

Sample No.-
21

Trial	1	2
Mass of Pycnometer	22.78	23.61
Mass of Pycnometer + Soil	32.78	33.74
Mass of Pycnometer + Water	73.88	75.05
Mass of Pycnometer + Soil + Water	80.06	81.31
Specific Gravity	2.62	2.62
Average	2.62	

Sample No.-
22

Trial	1	2
Mass of Pycnometer	23.61	22.78
Mass of Pycnometer + Soil	33.74	32.78
Mass of Pycnometer + Water	75.05	73.88
Mass of Pycnometer + Soil + Water	81.32	80.08
Specific Gravity	2.62	2.63
Average	2.63	

Sample No.-
29

Trial	1	2
Mass of Pycnometer	24.43	22.78
Mass of Pycnometer + Soil	34.43	32.78
Mass of Pycnometer + Water	75.47	73.88
Mass of Pycnometer + Soil + Water	81.67	80.07
Specific Gravity	2.63	2.62
Average	2.63	

Sample No.-
30

Trial	1	2
Mass of Pycnometer	22.78	23.61
Mass of Pycnometer + Soil	32.78	33.74
Mass of Pycnometer + Water	73.88	75.05
Mass of Pycnometer + Soil + Water	80.03	81.29
Specific Gravity	2.60	2.60
Average	2.60	

Sample No.-
33

Trial	1	2
Mass of Pycnometer	24.43	22.78
Mass of Pycnometer + Soil	34.43	32.78
Mass of Pycnometer + Water	75.47	73.88
Mass of Pycnometer + Soil + Water	81.68	80.10
Specific Gravity	2.64	2.65
Average	2.64	

Sample No.-
34

Trial	1	2
Mass of Pycnometer	24.43	22.78
Mass of Pycnometer + Soil	34.43	32.78
Mass of Pycnometer + Water	75.76	73.88
Mass of Pycnometer + Soil + Water	81.96	80.07
Specific Gravity	2.63	2.62
Average	2.63	

APPENDIX B – ATTERBERG LIMIT TEST RESULTS

SOAKED CBR VALUE DETERMINATION FROM LABORATORY DCP TEST FOR ADDIS ABABA RED CLAY SOIL

Sample No. 1

No. of blows	Liquid Limit			Plastic Limit	
	33	24	16		
Wt. of wet soil + Can (gm)	51.94	52.04	50.84	29.21	28.98
Wt. of dry soil + Can (gm)	40.40	40.47	39.29	27.04	26.82
Wt. of Water (gm)	11.54	11.57	11.55	2.17	2.16
Wt. of Can (gm)	20.00	20.41	19.84	20.07	19.89
Wt. of dry soil (gm)	20.40	20.06	19.45	6.97	6.93
Moisture Content(%)	56.57	57.68	59.38	31.13	31.17
Average PL(%)=				31.15	

Liquid Limit (%) 58

Plastic Limit (%) 31

Plasticity Index (%) 27

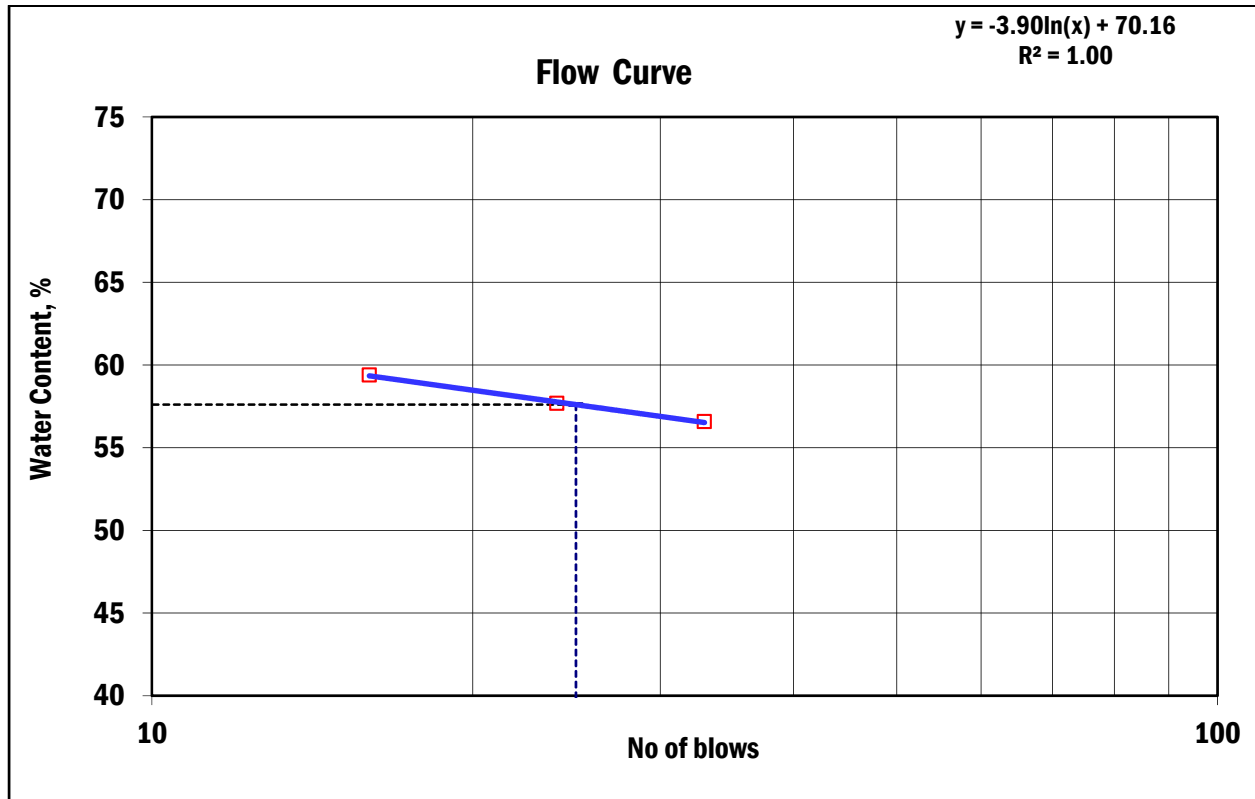

SOAKED CBR VALUE DETERMINATION FROM LABORATORY DCP TEST FOR ADDIS ABABA RED CLAY SOIL

**Sample
No. 2**

No. of blows	Liquid Limit			Plastic Limit	
	34	26	17		
Wt. of wet soil + Can (gm)	50.00	50.33	50.82	28.08	28.05
Wt. of dry soil + Can (gm)	38.70	38.80	38.99	26.08	26.06
Wt. of Water (gm)	11.30	11.53	11.83	2.00	1.99
Wt. of Can (gm)	20.24	20.47	20.75	20.20	20.21
Wt. of dry soil (gm)	18.46	18.33	18.24	5.88	5.85
Moisture Content(%)	61.21	62.90	64.86	34.01	34.02
Average PL(%)=				34.02	

Liquid Limit (%) 63

Plastic Limit (%) 34

Plasticity Index (%) 29

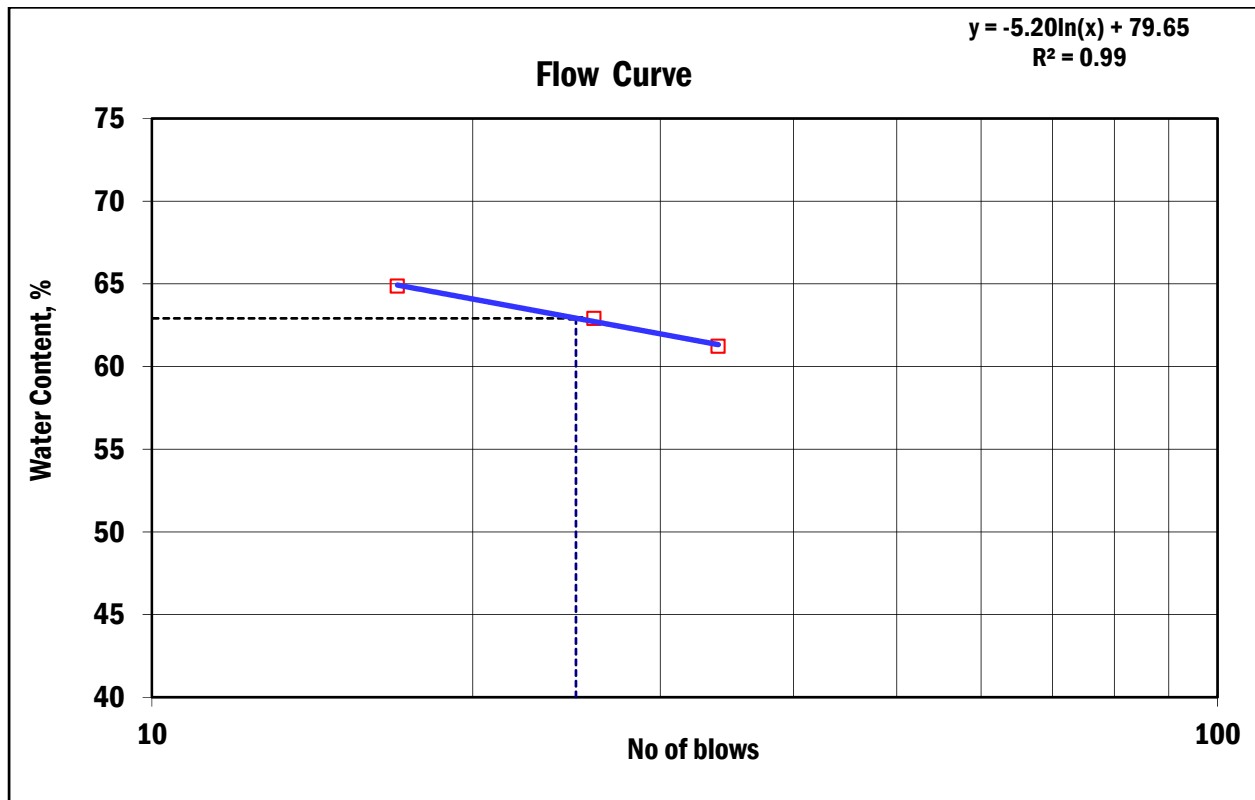

SOAKED CBR VALUE DETERMINATION FROM LABORATORY DCP TEST FOR ADDIS ABABA RED CLAY SOIL

Sample No. 3

No. of blows	Liquid Limit			Plastic Limit	
	32	24	16		
Wt. of wet soil + Can (gm)	50.14	50.99	48.96	26.91	27.23
Wt. of dry soil + Can (gm)	38.40	38.98	37.23	25.09	25.29
Wt. of Water (gm)	11.74	12.01	11.73	1.82	1.94
Wt. of Can (gm)	20.25	20.75	19.89	19.84	19.75
Wt. of dry soil (gm)	18.15	18.23	17.34	5.25	5.54
Moisture Content(%)	64.68	65.88	67.65	34.67	35.02
Average PL(%)=				34.84	

Liquid Limit (%) 66

Plastic Limit (%) 35

Plasticity Index (%) 31

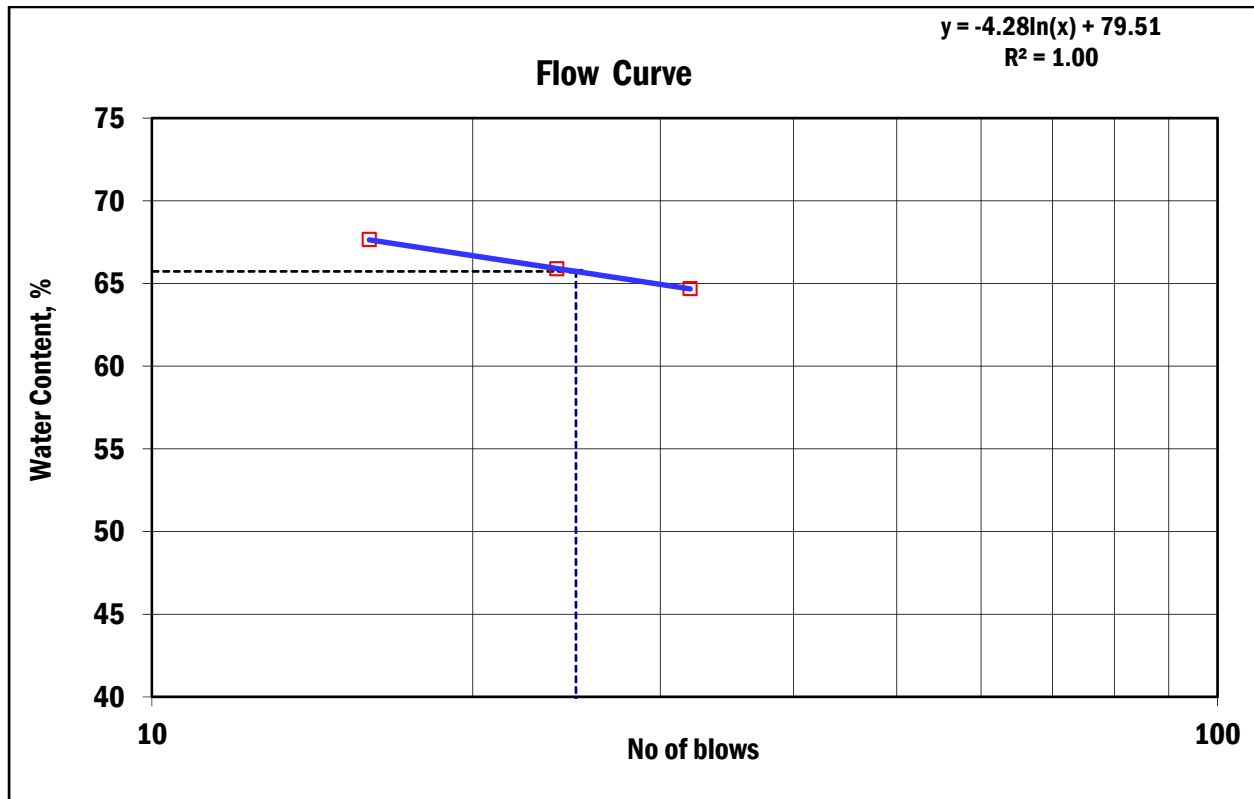

SOAKED CBR VALUE DETERMINATION FROM LABORATORY DCP TEST FOR ADDIS ABABA RED CLAY SOIL

Sample No. 4

No. of blows	Liquid Limit			Plastic Limit	
	35	24	16		
Wt. of wet soil + Can (gm)	40.63	39.58	41.95	27.31	27.18
Wt. of dry soil + Can (gm)	33.09	32.52	33.84	25.30	25.21
Wt. of Water (gm)	7.54	7.06	8.11	2.01	1.97
Wt. of Can (gm)	20.14	20.57	20.32	19.76	19.78
Wt. of dry soil (gm)	12.95	11.95	13.52	5.54	5.43
Moisture Content (%)	58.22	59.08	59.99	36.28	36.28
Average PL(%)=				36.28	

Liquid Limit (%) 59

Plastic Limit (%) 36

Plasticity Index (%) 23

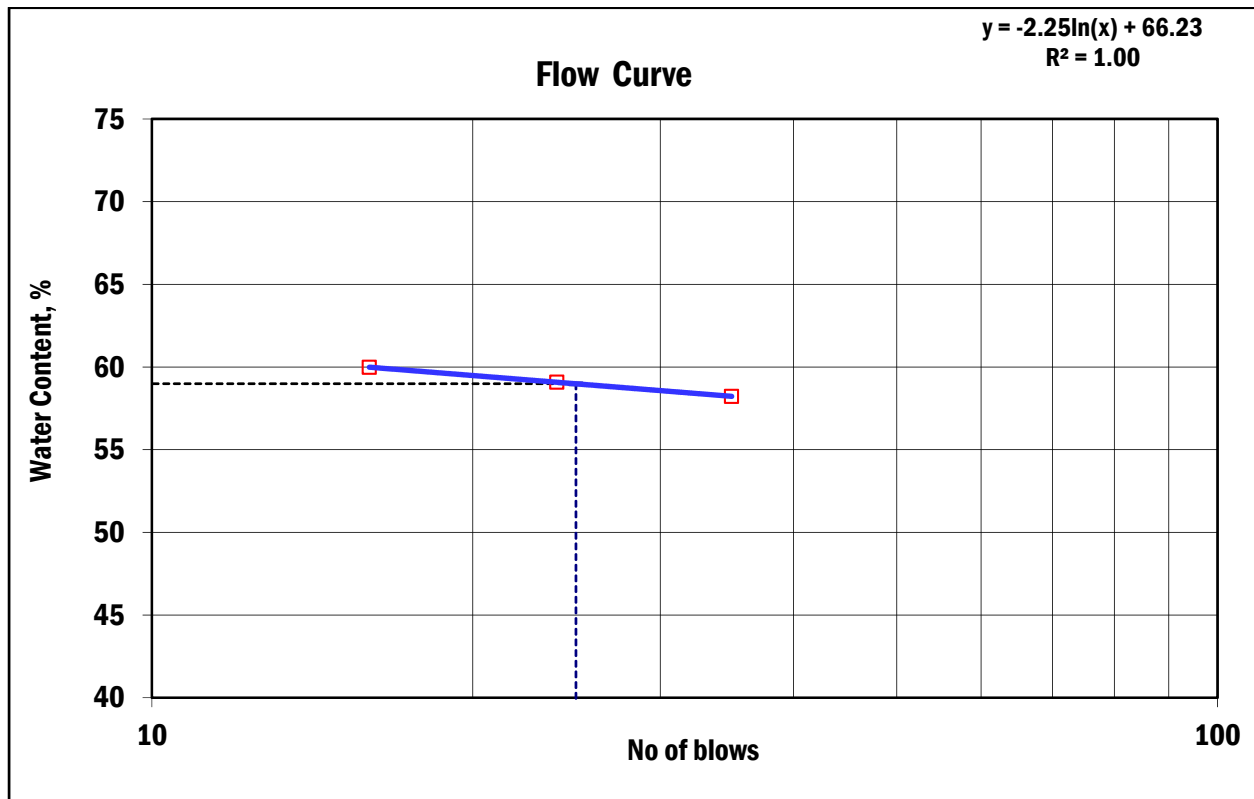

SOAKED CBR VALUE DETERMINATION FROM LABORATORY DCP TEST FOR ADDIS ABABA RED CLAY SOIL

Sample No. 5

No. of blows	Liquid Limit			Plastic Limit	
	32	26	18		
Wt. of wet soil + Can (gm)	41.14	45.75	39.78	29.41	29.35
Wt. of dry soil + Can (gm)	33.39	36.35	32.55	26.92	26.88
Wt. of Water (gm)	7.75	9.40	7.23	2.49	2.47
Wt. of Can (gm)	20.48	20.91	20.90	19.85	19.82
Wt. of dry soil (gm)	12.91	15.44	11.65	7.07	7.06
Moisture Content(%)	60.03	60.88	62.06	35.22	34.99
Average PL(%)=				35.10	

Liquid Limit (%) 61

Plastic Limit (%) 35

Plasticity Index (%) 26



SOAKED CBR VALUE DETERMINATION FROM LABORATORY DCP TEST FOR ADDIS ABABA RED CLAY SOIL

Sample No. 6

No. of blows	Liquid Limit			Plastic Limit	
	35	25	19		
Wt. of wet soil + Can (gm)	40.17	41.34	43.83	28.62	28.42
Wt. of dry soil + Can (gm)	32.65	33.18	34.82	26.28	26.17
Wt. of Water (gm)	7.52	8.16	9.01	2.34	2.25
Wt. of Can (gm)	20.53	20.23	20.75	19.80	19.86
Wt. of dry soil (gm)	12.12	12.95	14.07	6.48	6.31
Moisture Content(%)	62.05	63.01	64.04	36.11	35.66
Average PL(%)=				35.88	

Liquid Limit (%) 63

Plastic Limit (%) 36

Plasticity Index (%) 27

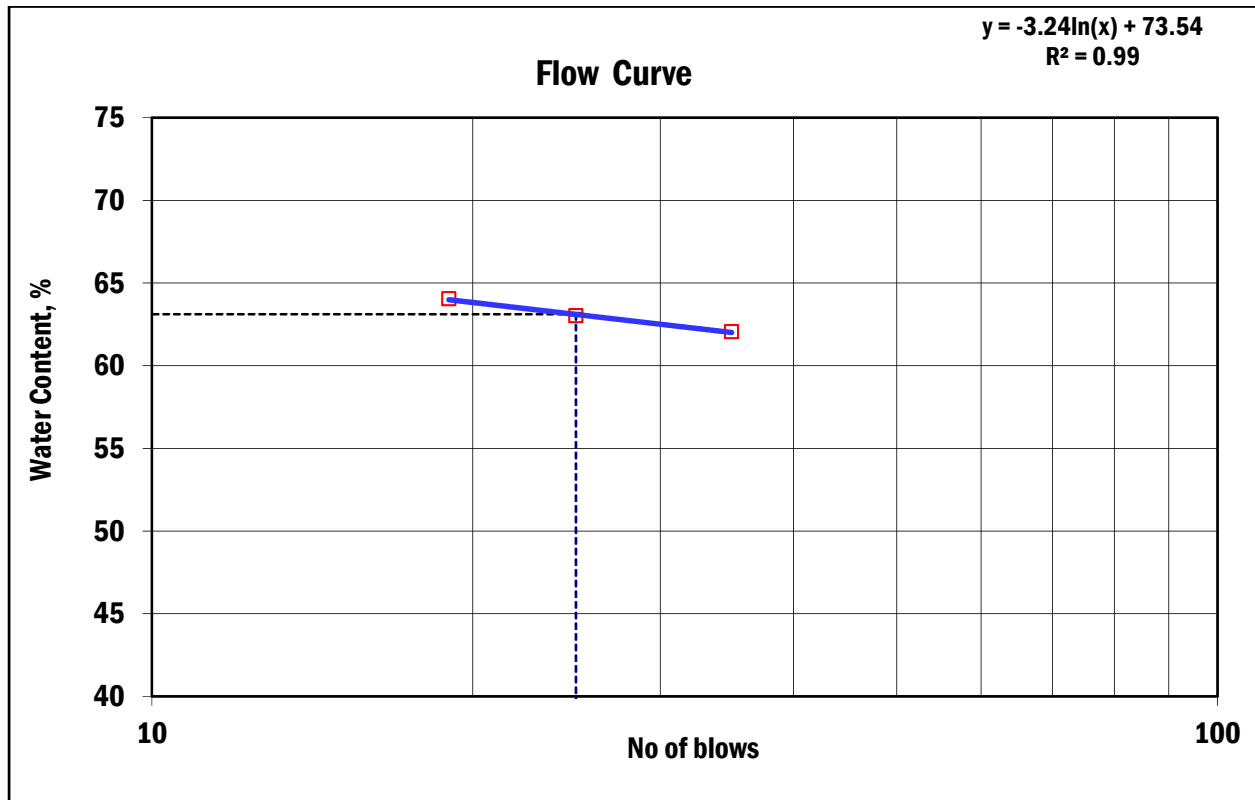

SOAKED CBR VALUE DETERMINATION FROM LABORATORY DCP TEST FOR ADDIS ABABA RED CLAY SOIL

Sample No. 7

No. of blows	Liquid Limit			Plastic Limit	
	34	27	19		
Wt. of wet soil + Can (gm)	49.86	47.84	50.98	28.51	28.97
Wt. of dry soil + Can (gm)	38.82	37.29	39.00	26.47	26.93
Wt. of Water (gm)	11.04	10.55	11.98	2.04	2.04
Wt. of Can (gm)	20.13	19.89	19.76	20.28	20.69
Wt. of dry soil (gm)	18.69	17.40	19.24	6.19	6.24
Moisture Content (%)	59.07	60.63	62.27	32.96	32.69
Average PL(%)=				32.82	

Liquid Limit (%) 61

Plastic Limit (%) 33

Plasticity Index (%) 28



SOAKED CBR VALUE DETERMINATION FROM LABORATORY DCP TEST FOR ADDIS ABABA RED CLAY SOIL

Sample No. 8

No. of blows	Liquid Limit			Plastic Limit	
	33	26	17		
Wt. of wet soil + Can (gm)	49.23	50.14	49.05	28.42	28.21
Wt. of dry soil + Can (gm)	38.45	39.03	38.19	26.50	26.29
Wt. of Water (gm)	10.78	11.11	10.86	1.92	1.92
Wt. of Can (gm)	20.28	20.59	20.63	20.69	20.50
Wt. of dry soil (gm)	18.17	18.44	17.56	5.81	5.79
Moisture Content(%)	59.33	60.25	61.85	33.05	33.16
Average PL(%)=				33.10	

Liquid Limit (%) 60

Plastic Limit (%) 33

Plasticity Index (%) 27

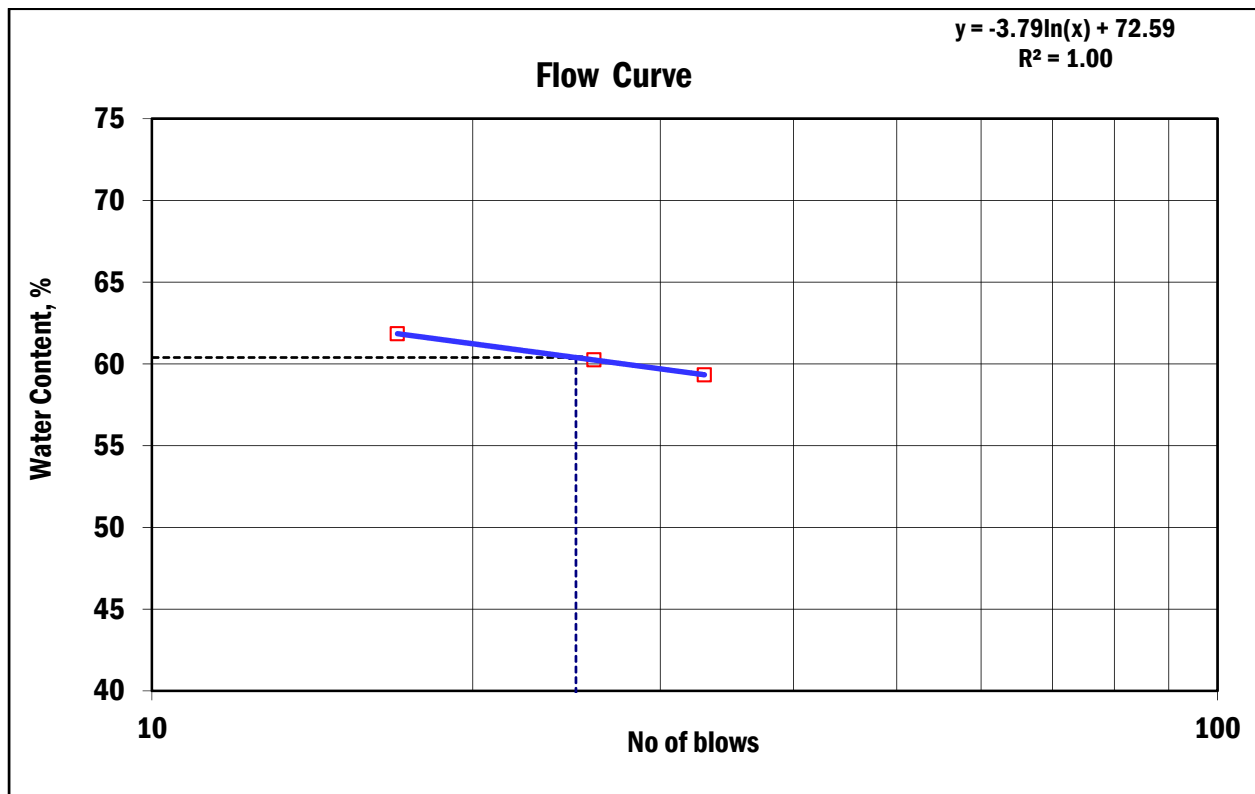

SOAKED CBR VALUE DETERMINATION FROM LABORATORY DCP TEST FOR ADDIS ABABA RED CLAY SOIL

Sample No. 9

No. of blows	Liquid Limit			Plastic Limit	
	32	23	17		
Wt. of wet soil + Can (gm)	43.29	42.78	44.65	27.78	27.61
Wt. of dry soil + Can (gm)	34.94	34.47	35.37	25.85	25.72
Wt. of Water (gm)	8.35	8.31	9.28	1.93	1.89
Wt. of Can (gm)	20.80	20.62	20.18	19.80	19.81
Wt. of dry soil (gm)	14.14	13.85	15.19	6.05	5.91
Moisture Content(%)	59.05	60.00	61.09	31.90	31.98
Average PL(%)=				31.94	

Liquid Limit (%) 60

Plastic Limit (%) 32

Plasticity Index (%) 28

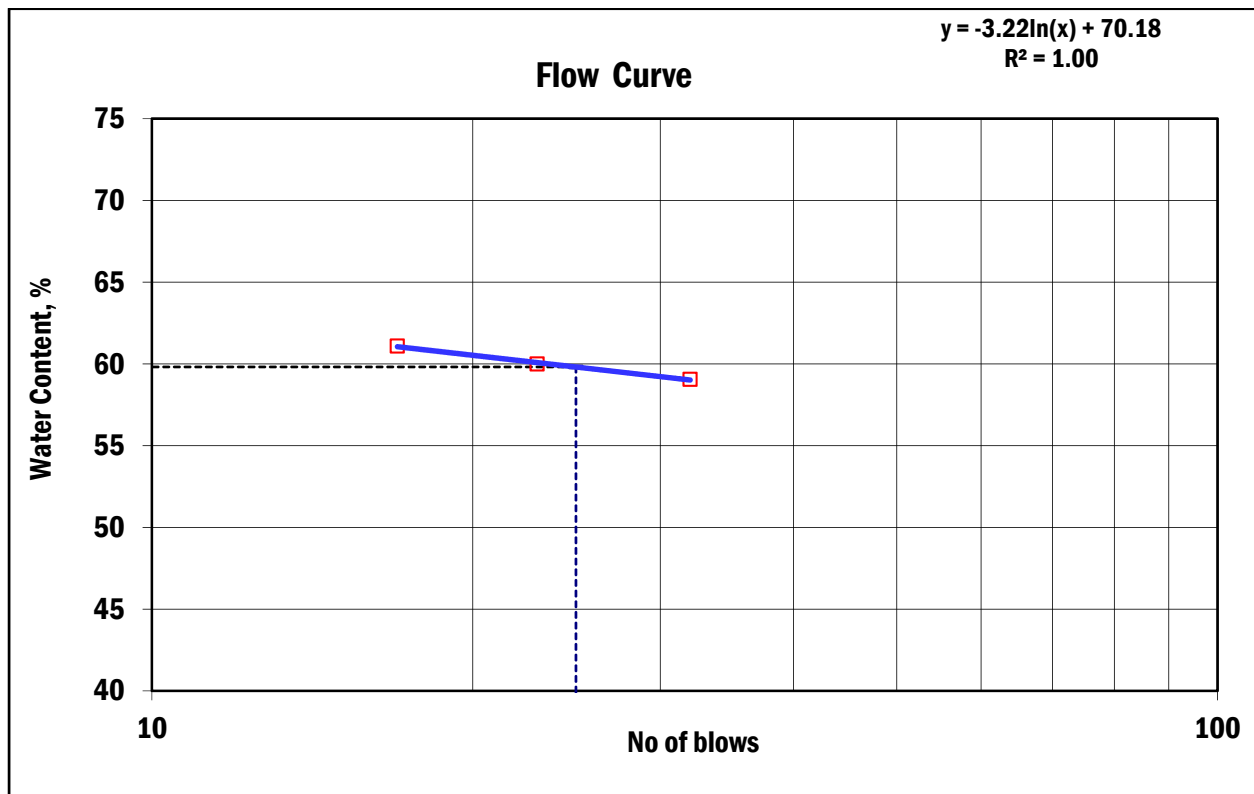

SOAKED CBR VALUE DETERMINATION FROM LABORATORY DCP TEST FOR ADDIS ABABA RED CLAY SOIL

Sample No. 10

No. of blows	Liquid Limit			Plastic Limit	
	33	25	19		
Wt. of wet soil + Can (gm)	44.17	45.31	41.14	27.23	27.12
Wt. of dry soil + Can (gm)	35.49	36.22	33.41	25.33	25.23
Wt. of Water (gm)	8.68	9.09	7.73	1.90	1.89
Wt. of Can (gm)	20.64	20.89	20.57	19.91	19.78
Wt. of dry soil (gm)	14.85	15.33	12.84	5.42	5.45
Moisture Content (%)	58.45	59.30	60.20	35.06	34.68
Average PL(%)=				34.87	

Liquid Limit (%) 59

Plastic Limit (%) 35

Plasticity Index (%) 24

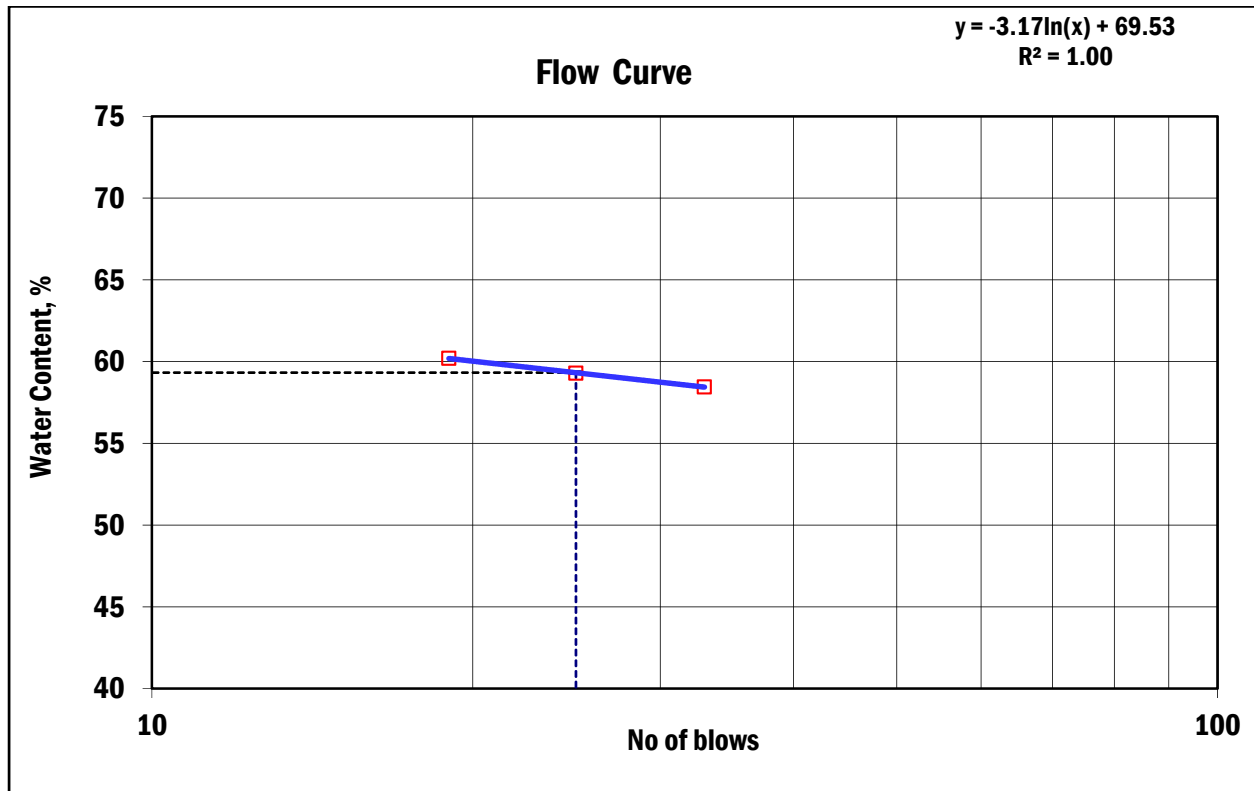

SOAKED CBR VALUE DETERMINATION FROM LABORATORY DCP TEST FOR ADDIS ABABA RED CLAY SOIL

Sample No. 11

No. of blows	Liquid Limit			Plastic Limit	
	35	25	19		
Wt. of wet soil + Can (gm)	43.98	42.84	39.53	28.19	28.10
Wt. of dry soil + Can (gm)	36.26	35.40	33.09	26.03	25.97
Wt. of Water (gm)	7.72	7.44	6.44	2.16	2.13
Wt. of Can (gm)	20.54	20.65	20.64	19.88	19.89
Wt. of dry soil (gm)	15.72	14.75	12.45	6.15	6.08
Moisture Content(%)	49.11	50.44	51.73	35.12	35.03
Average PL(%)=				35.08	

Liquid Limit (%) 51

Plastic Limit (%) 35

Plasticity Index (%) 16

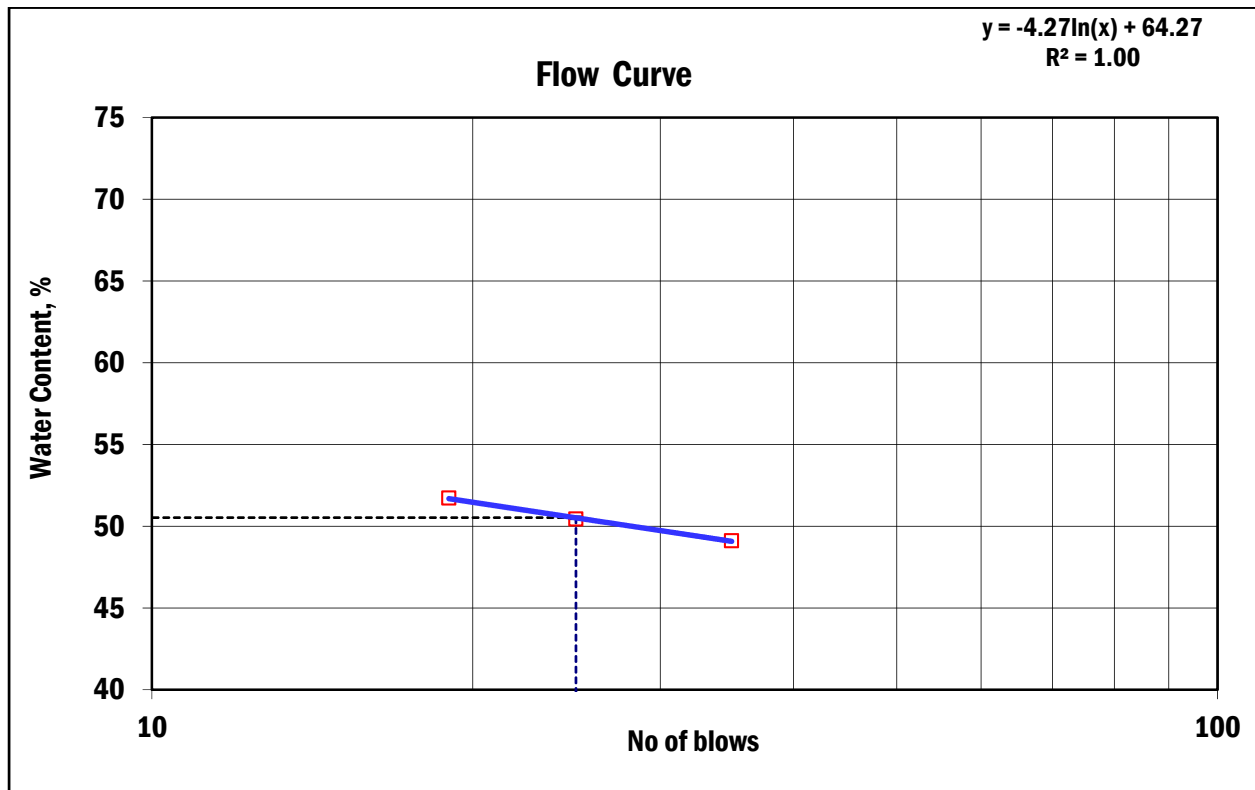

SOAKED CBR VALUE DETERMINATION FROM LABORATORY DCP TEST FOR ADDIS ABABA RED CLAY SOIL

Sample No. 12

No. of blows	Liquid Limit			Plastic Limit	
	34	25	18		
Wt. of wet soil + Can (gm)	43.13	42.77	44.35	27.37	27.21
Wt. of dry soil + Can (gm)	35.35	35.02	35.87	25.65	25.58
Wt. of Water (gm)	7.78	7.75	8.48	1.72	1.63
Wt. of Can (gm)	20.72	20.70	20.55	19.76	19.89
Wt. of dry soil (gm)	14.63	14.32	15.32	5.89	5.69
Moisture Content (%)	53.18	54.12	55.35	29.20	28.65
Average PL(%)=				28.92	

Liquid Limit (%) 54

Plastic Limit (%) 29

Plasticity Index (%) 25

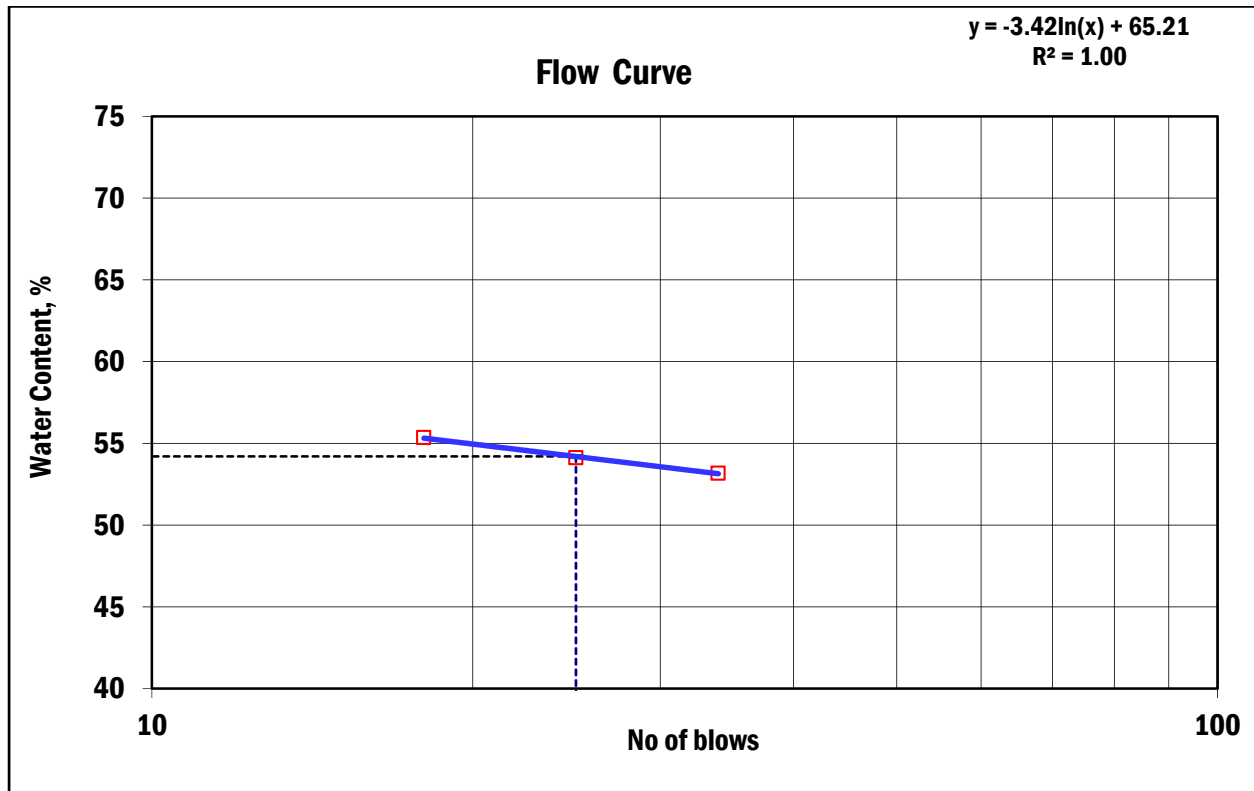

SOAKED CBR VALUE DETERMINATION FROM LABORATORY DCP TEST FOR ADDIS ABABA RED CLAY SOIL

Sample No. 13

No. of blows	Liquid Limit			Plastic Limit	
	35	25	18		
Wt. of wet soil + Can (gm)	43.01	42.51	41.70	28.71	28.57
Wt. of dry soil + Can (gm)	35.89	35.43	34.80	26.78	26.65
Wt. of Water (gm)	7.12	7.08	6.90	1.93	1.92
Wt. of Can (gm)	20.61	20.64	20.69	19.98	19.87
Wt. of dry soil (gm)	15.28	14.79	14.11	6.80	6.78
Moisture Content(%)	46.60	47.87	48.90	28.38	28.32
Average PL(%)=				28.35	

Liquid Limit (%) 48

Plastic Limit (%) 28

Plasticity Index (%) 20

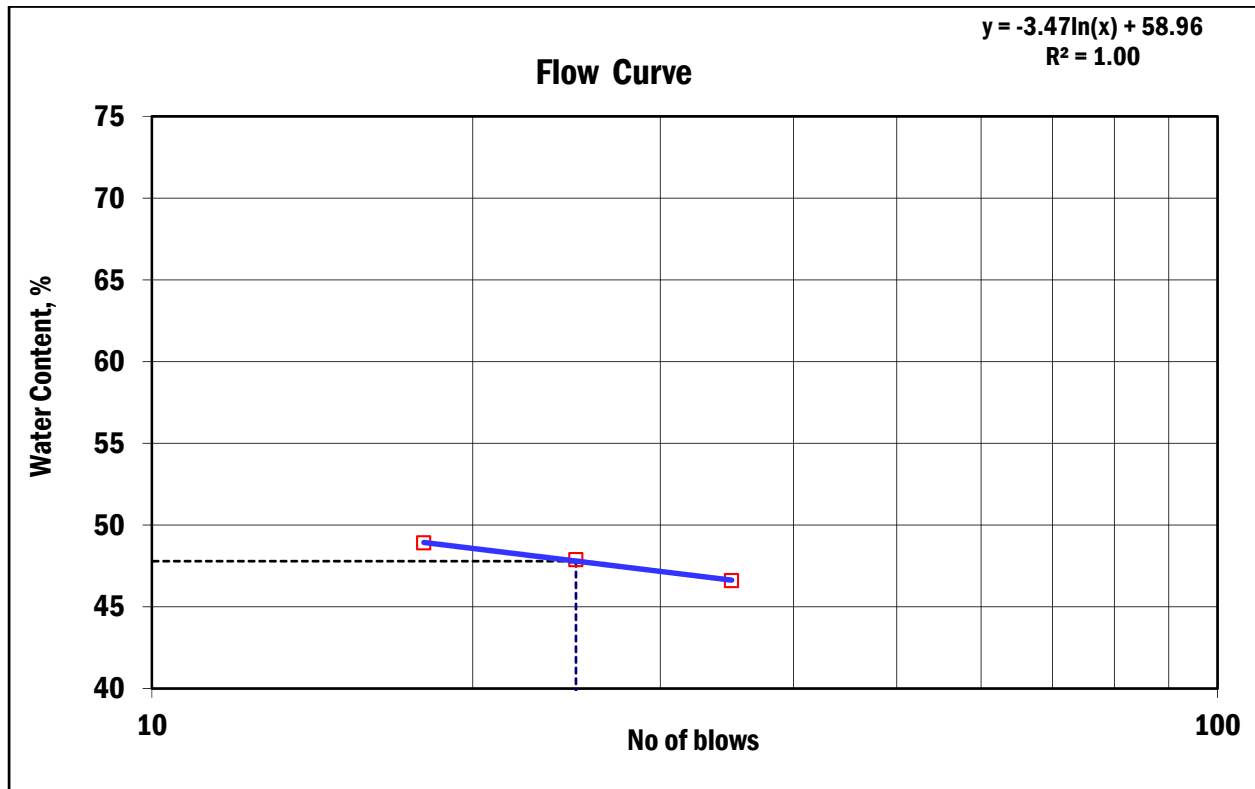

SOAKED CBR VALUE DETERMINATION FROM LABORATORY DCP TEST FOR ADDIS ABABA RED CLAY SOIL

Sample No. 14

No. of blows	Liquid Limit			Plastic Limit	
	34	26	19		
Wt. of wet soil + Can (gm)	52.37	50.20	52.17	30.03	30.48
Wt. of dry soil + Can (gm)	42.30	40.41	41.85	27.85	28.27
Wt. of Water (gm)	10.07	9.79	10.32	2.18	2.21
Wt. of Can (gm)	20.61	19.77	20.70	20.22	20.59
Wt. of dry soil (gm)	21.69	20.64	21.15	7.63	7.68
Moisture Content(%)	46.43	47.43	48.79	28.57	28.78
Average PL(%)=				28.67	

Liquid Limit (%) 48

Plastic Limit (%) 29

Plasticity Index (%) 19

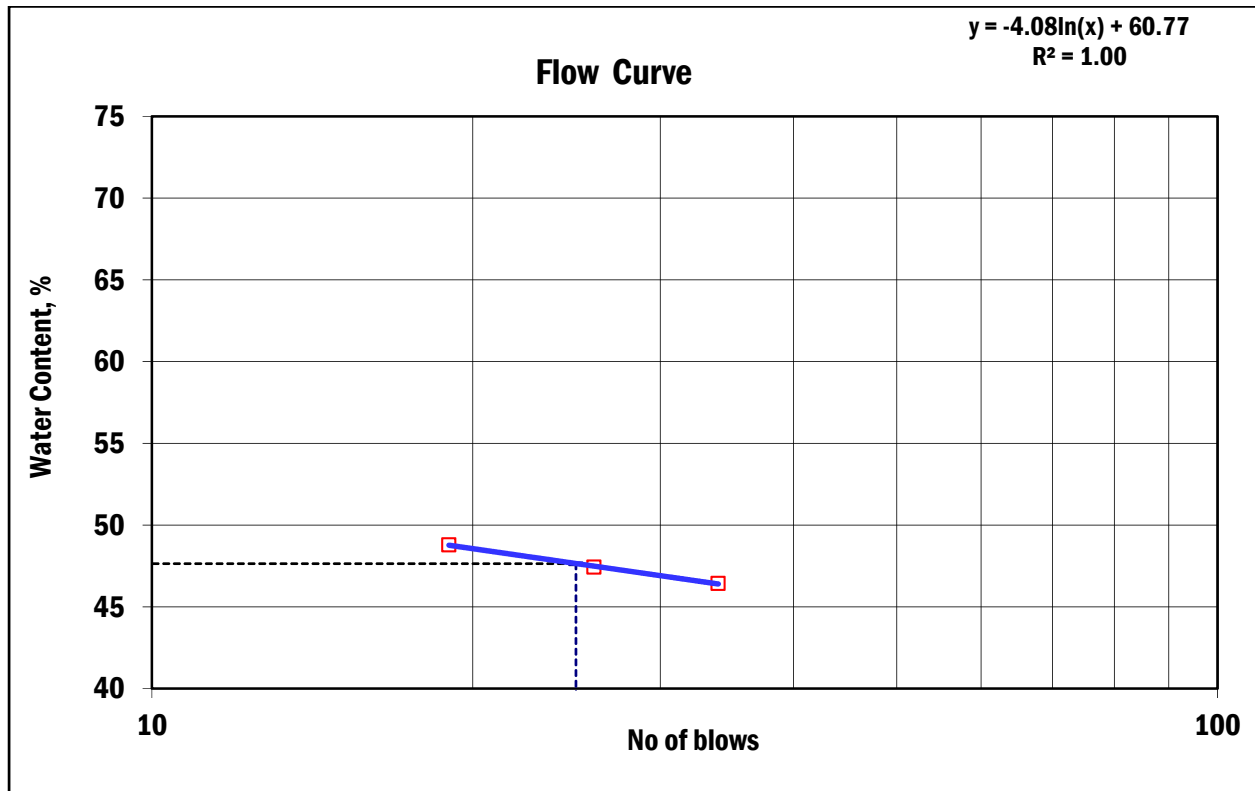

SOAKED CBR VALUE DETERMINATION FROM LABORATORY DCP TEST FOR ADDIS ABABA RED CLAY SOIL

Sample No. 15

No. of blows	Liquid Limit			Plastic Limit	
	33	24	19		
Wt. of wet soil + Can (gm)	43.08	43.45	44.75	28.65	28.55
Wt. of dry soil + Can (gm)	36.16	36.31	37.10	26.79	26.71
Wt. of Water (gm)	6.92	7.14	7.65	1.86	1.84
Wt. of Can (gm)	20.65	20.75	20.80	19.76	19.92
Wt. of dry soil (gm)	15.51	15.56	16.30	7.03	6.79
Moisture Content(%)	44.62	45.89	46.93	26.46	27.10
Average PL(%)=				26.78	

Liquid Limit (%) 46

Plastic Limit (%) 27

Plasticity Index (%) 19



SOAKED CBR VALUE DETERMINATION FROM LABORATORY DCP TEST FOR ADDIS ABABA RED CLAY SOIL

Sample No. 17

No. of blows	Liquid Limit			Plastic Limit	
	33	26	17		
Wt. of wet soil + Can (gm)	51.16	52.86	50.13	29.24	29.32
Wt. of dry soil + Can (gm)	41.34	42.47	40.29	27.42	27.50
Wt. of Water (gm)	9.82	10.39	9.84	1.82	1.82
Wt. of Can (gm)	20.00	20.59	20.41	20.59	20.66
Wt. of dry soil (gm)	21.34	21.88	19.88	6.83	6.84
Moisture Content(%)	46.02	47.49	49.50	26.65	26.61
Average PL(%)=				26.63	

Liquid Limit (%) 47

Plastic Limit (%) 27

Plasticity Index (%) 20

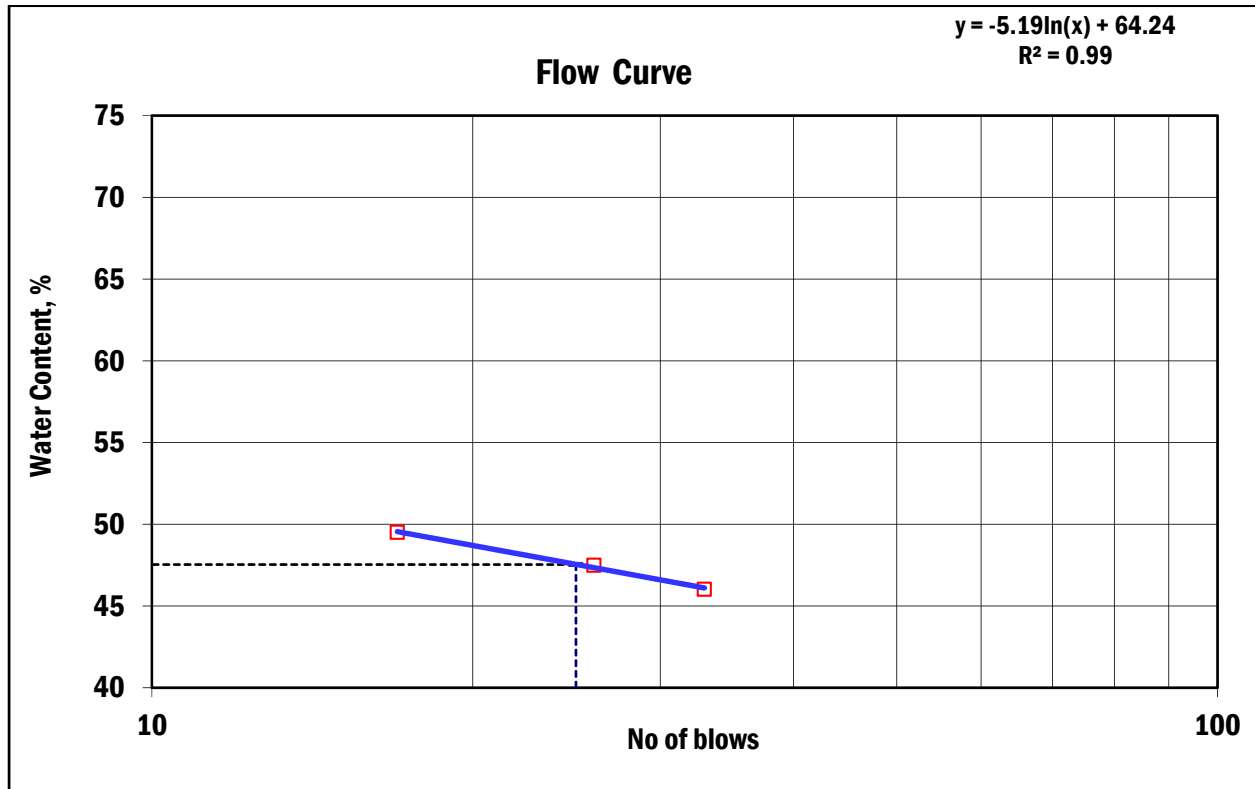

SOAKED CBR VALUE DETERMINATION FROM LABORATORY DCP TEST FOR ADDIS ABABA RED CLAY SOIL

Sample No. 18

No. of blows	Liquid Limit			Plastic Limit	
	35	27	17		
Wt. of wet soil + Can (gm)	42.80	42.20	40.39	27.28	27.21
Wt. of dry soil + Can (gm)	35.21	34.71	33.36	25.56	25.49
Wt. of Water (gm)	7.59	7.49	7.03	1.72	1.72
Wt. of Can (gm)	20.31	20.33	20.10	19.81	19.78
Wt. of dry soil (gm)	14.90	14.38	13.26	5.75	5.71
Moisture Content(%)	50.94	52.09	53.02	29.91	30.12
Average PL(%)=				30.02	

Liquid Limit (%) 52

Plastic Limit (%) 30

Plasticity Index (%) 22

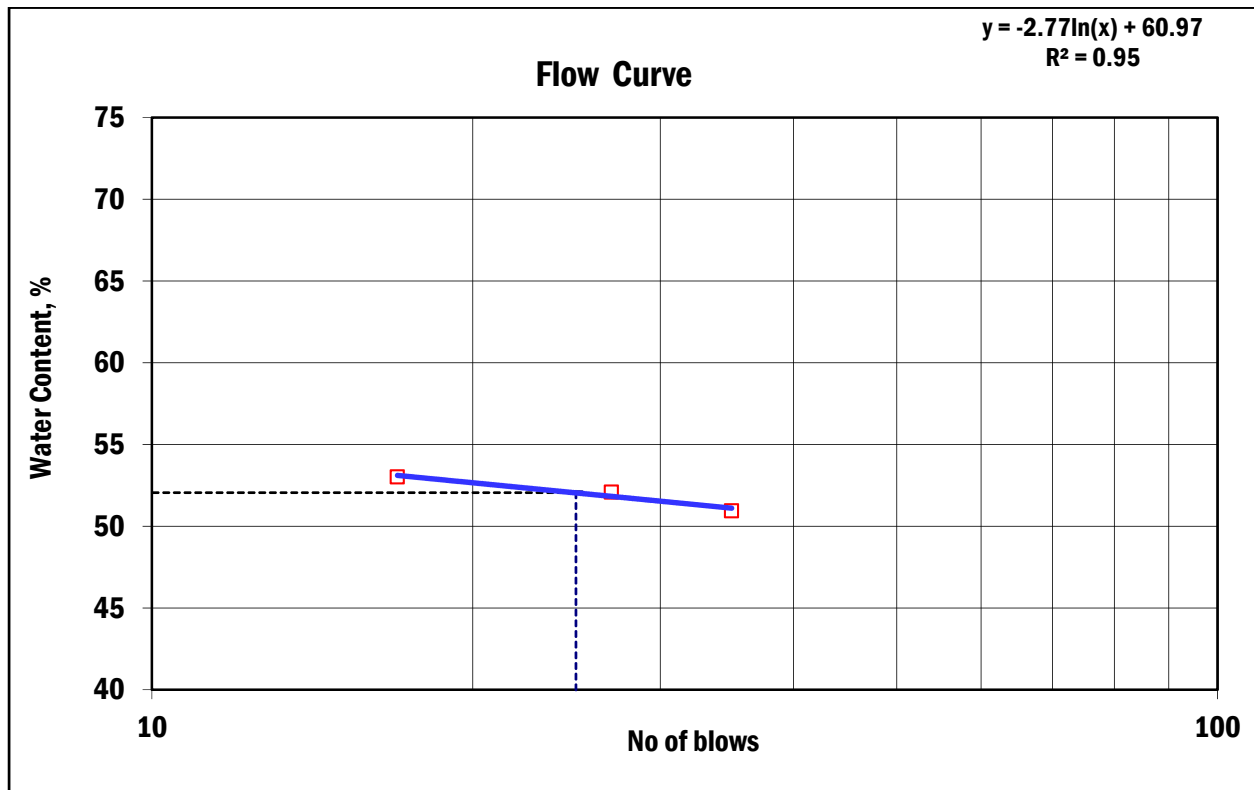

SOAKED CBR VALUE DETERMINATION FROM LABORATORY DCP TEST FOR ADDIS ABABA RED CLAY SOIL

Sample No. 19

No. of blows	Liquid Limit			Plastic Limit	
	33	26	19		
Wt. of wet soil + Can (gm)	50.48	51.89	50.38	29.34	29.11
Wt. of dry soil + Can (gm)	40.40	41.35	40.06	27.28	27.01
Wt. of Water (gm)	10.08	10.54	10.32	2.06	2.10
Wt. of Can (gm)	20.41	20.78	20.51	20.68	20.28
Wt. of dry soil (gm)	19.99	20.57	19.55	6.60	6.73
Moisture Content (%)	50.43	51.24	52.79	31.21	31.20
Average PL(%)=				31.21	

Liquid Limit (%) 52

Plastic Limit (%) 31

Plasticity Index (%) 21



SOAKED CBR VALUE DETERMINATION FROM LABORATORY DCP TEST FOR ADDIS ABABA RED CLAY SOIL

Sample No. 21

No. of blows	Liquid Limit			Plastic Limit	
	33	24	16		
Wt. of wet soil + Can (gm)	51.00	51.53	51.37	27.36	27.61
Wt. of dry soil + Can (gm)	40.95	41.10	41.09	25.80	25.83
Wt. of Water (gm)	10.05	10.43	10.28	1.56	1.78
Wt. of Can (gm)	20.04	19.91	20.88	20.69	20.11
Wt. of dry soil (gm)	20.91	21.19	20.21	5.11	5.72
Moisture Content (%)	48.06	49.22	50.87	30.53	31.12
Average PL(%)=				30.82	

Liquid Limit (%) 49

Plastic Limit (%) 31

Plasticity Index (%) 18



SOAKED CBR VALUE DETERMINATION FROM LABORATORY DCP TEST FOR ADDIS ABABA RED CLAY SOIL

Sample No. 22

No. of blows	Liquid Limit			Plastic Limit	
	32	24	18		
Wt. of wet soil + Can (gm)	42.89	40.93	41.69	28.26	27.20
Wt. of dry soil + Can (gm)	34.55	33.38	33.70	26.17	25.37
Wt. of Water (gm)	8.34	7.55	7.99	2.09	1.83
Wt. of Can (gm)	20.43	20.87	20.69	19.82	19.88
Wt. of dry soil (gm)	14.12	12.51	13.01	6.35	5.49
Moisture Content (%)	59.07	60.35	61.41	32.91	33.33
Average PL(%)=				33.12	

Liquid Limit (%) 60

Plastic Limit (%) 33

Plasticity Index (%) 27

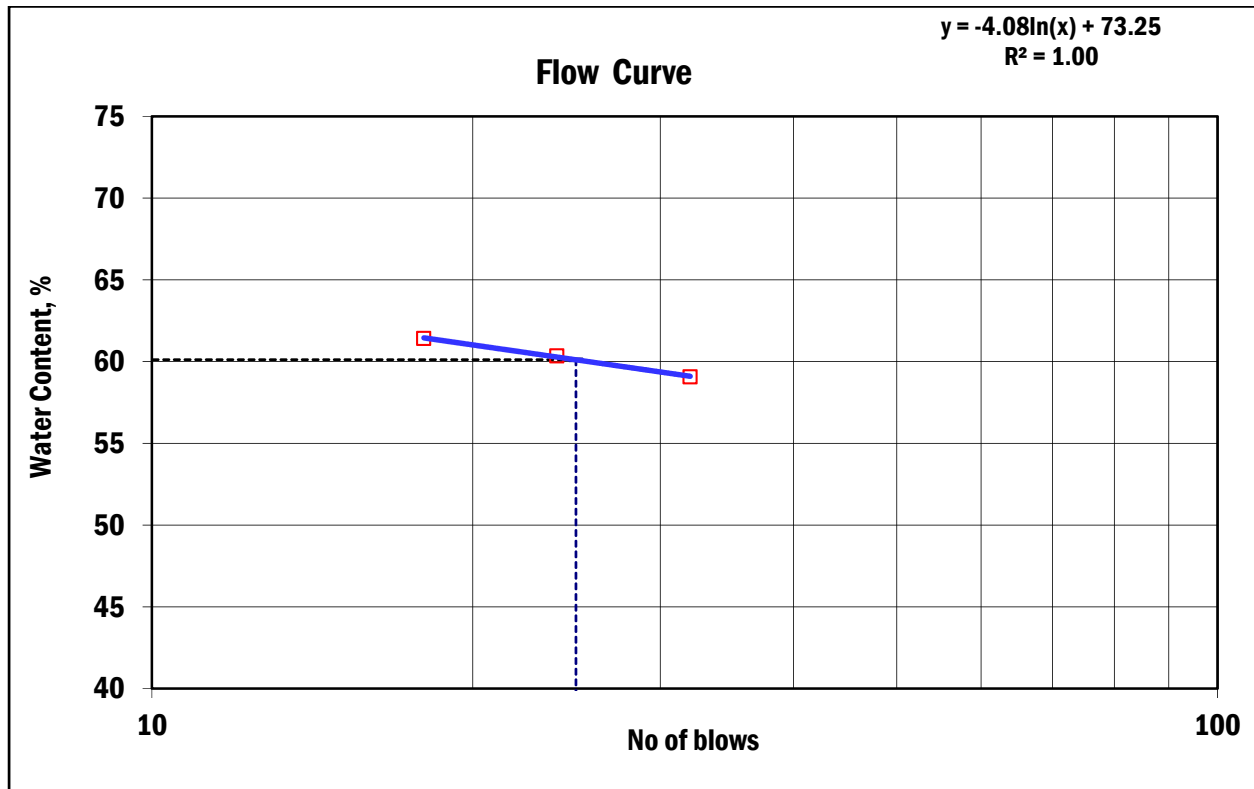

SOAKED CBR VALUE DETERMINATION FROM LABORATORY DCP TEST FOR ADDIS ABABA RED CLAY SOIL

Sample No. 29

No. of blows	Liquid Limit			Plastic Limit	
	35	25	19		
Wt. of wet soil + Can (gm)	41.29	39.75	43.40	28.22	28.08
Wt. of dry soil + Can (gm)	33.42	32.43	34.62	25.99	25.89
Wt. of Water (gm)	7.87	7.32	8.78	2.23	2.19
Wt. of Can (gm)	20.41	20.55	20.56	19.97	19.87
Wt. of dry soil (gm)	13.01	11.88	14.06	6.02	6.02
Moisture Content(%)	60.49	61.62	62.45	37.04	36.88
Average PL(%)=				36.71	

Liquid Limit (%) 62

Plastic Limit (%) 37

Plasticity Index (%) 25



SOAKED CBR VALUE DETERMINATION FROM LABORATORY DCP TEST FOR ADDIS ABABA RED CLAY SOIL

Sample No. 30

No. of blows	Liquid Limit			Plastic Limit	
	32	25	19		
Wt. of wet soil + Can (gm)	40.80	39.13	41.34	28.44	28.32
Wt. of dry soil + Can (gm)	33.22	32.23	33.47	26.29	26.20
Wt. of Water (gm)	7.58	6.90	7.87	2.15	2.12
Wt. of Can (gm)	20.38	20.74	20.63	19.79	19.76
Wt. of dry soil (gm)	12.84	11.49	12.84	6.50	6.44
Moisture Content (%)	59.03	60.05	61.29	33.08	32.92
Average PL(%)=				33.00	

Liquid Limit (%) 60

Plastic Limit (%) 33

Plasticity Index (%) 27

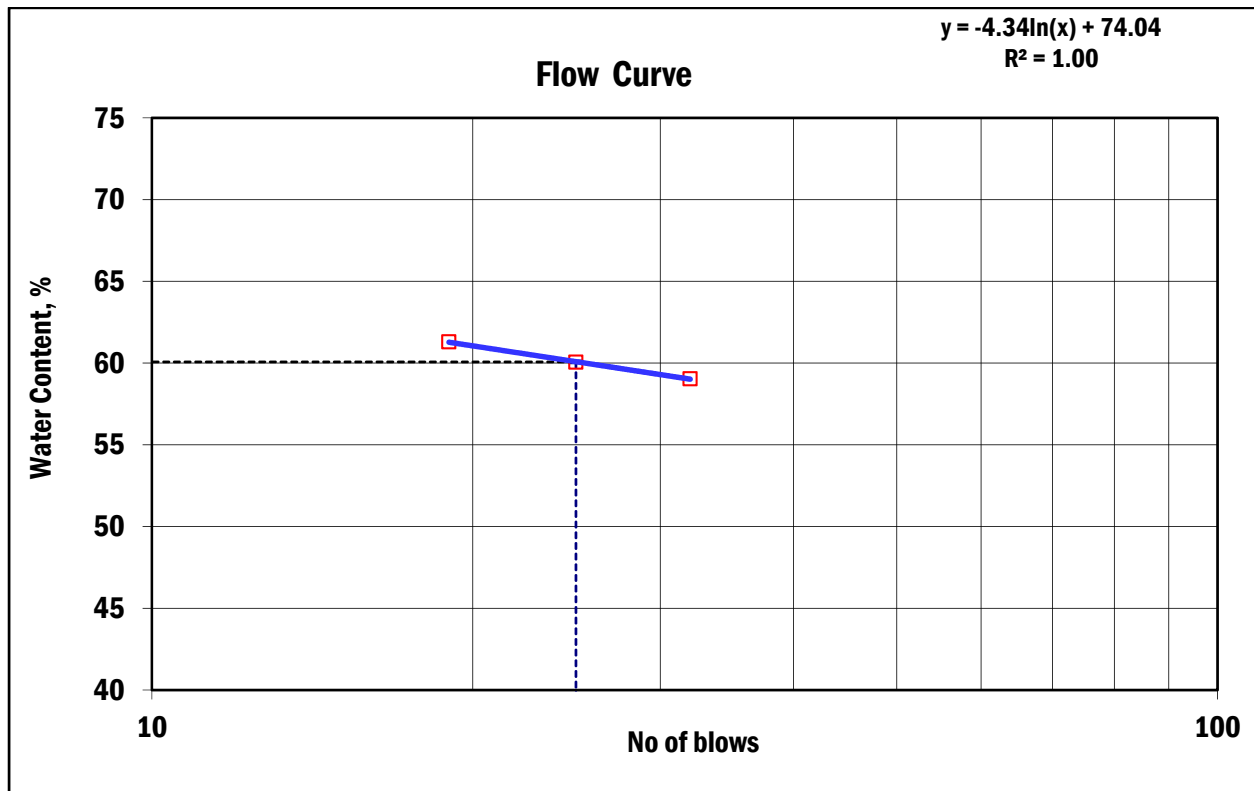

SOAKED CBR VALUE DETERMINATION FROM LABORATORY DCP TEST FOR ADDIS ABABA RED CLAY SOIL

Sample No. 33

No. of blows	Liquid Limit			Plastic Limit	
	32	24	18		
Wt. of wet soil + Can (gm)	44.98	43.44	41.97	27.31	27.19
Wt. of dry soil + Can (gm)	35.49	34.31	33.39	25.19	25.16
Wt. of Water (gm)	9.49	9.13	8.58	2.12	2.03
Wt. of Can (gm)	20.57	20.28	20.50	19.65	19.81
Wt. of dry soil (gm)	14.92	14.03	12.89	5.54	5.35
Moisture Content (%)	63.61	65.07	66.56	38.27	37.94
Average PL(%)=				38.11	

Liquid Limit (%) 65

Plastic Limit (%) 38

Plasticity Index (%) 27

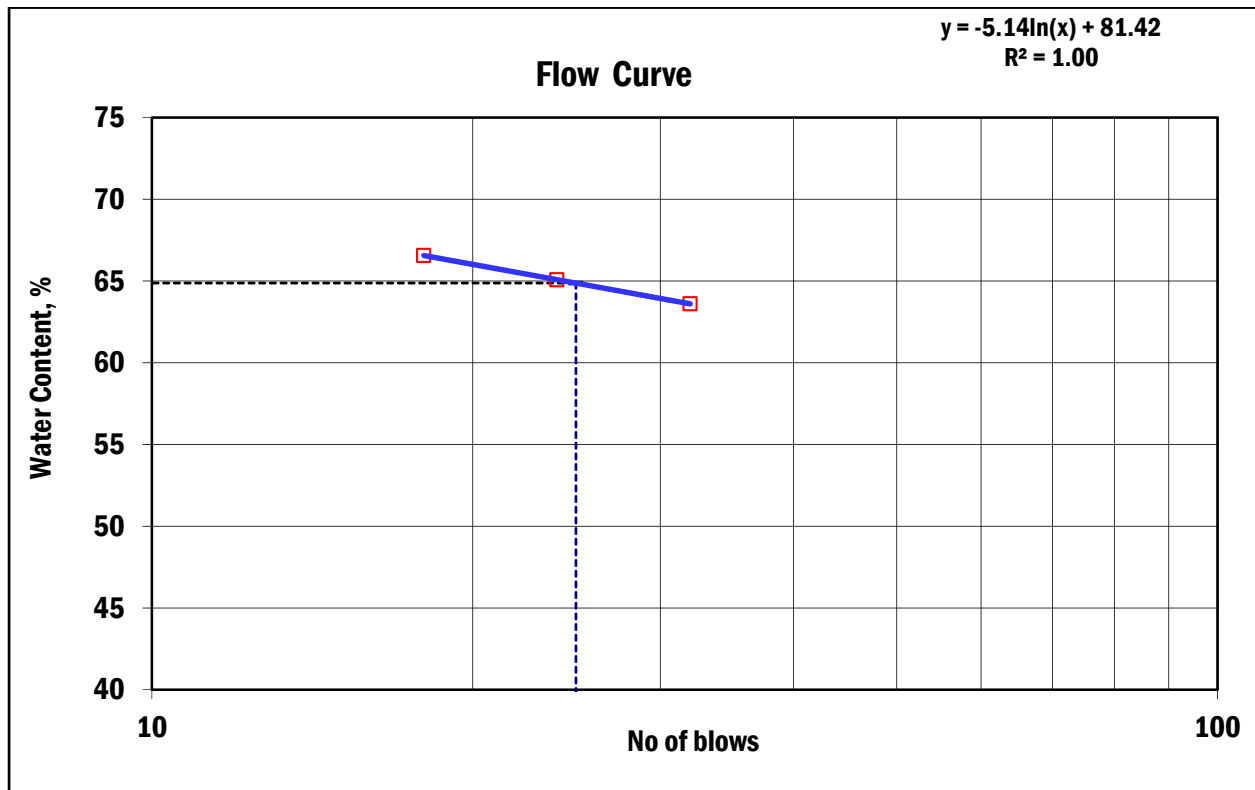

SOAKED CBR VALUE DETERMINATION FROM LABORATORY DCP TEST FOR ADDIS ABABA RED CLAY SOIL

Sample No. 34

No. of blows	Liquid Limit			Plastic Limit	
	34	26	17		
Wt. of wet soil + Can (gm)	44.84	47.89	45.44	28.39	28.13
Wt. of dry soil + Can (gm)	35.49	37.31	35.59	26.17	25.90
Wt. of Water (gm)	9.35	10.58	9.85	2.22	2.23
Wt. of Can (gm)	20.23	20.23	19.97	20.40	20.10
Wt. of dry soil (gm)	15.26	17.08	15.62	5.77	5.80
Moisture Content (%)	61.27	61.94	63.06	38.47	38.45
Average PL(%)=				38.46	

Liquid Limit (%) 62

Plastic Limit (%) 38

Plasticity Index (%) 24



**APPENDIX C – MOISTURE DENSITY RELATIONSHIP TEST
RESULTS**

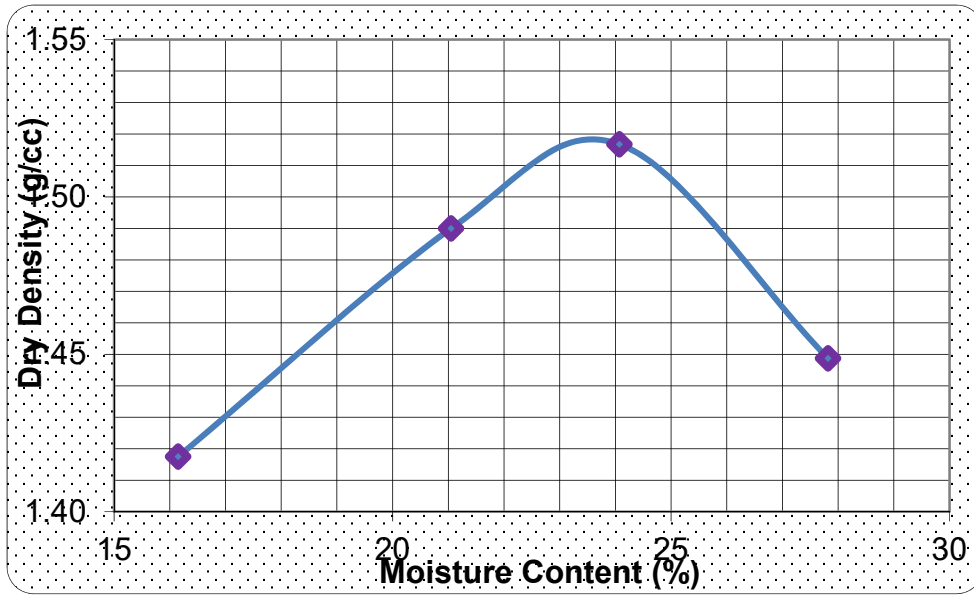

MDD (g/cc) 1.52

OMC (%) 23.5

Sample No. 1

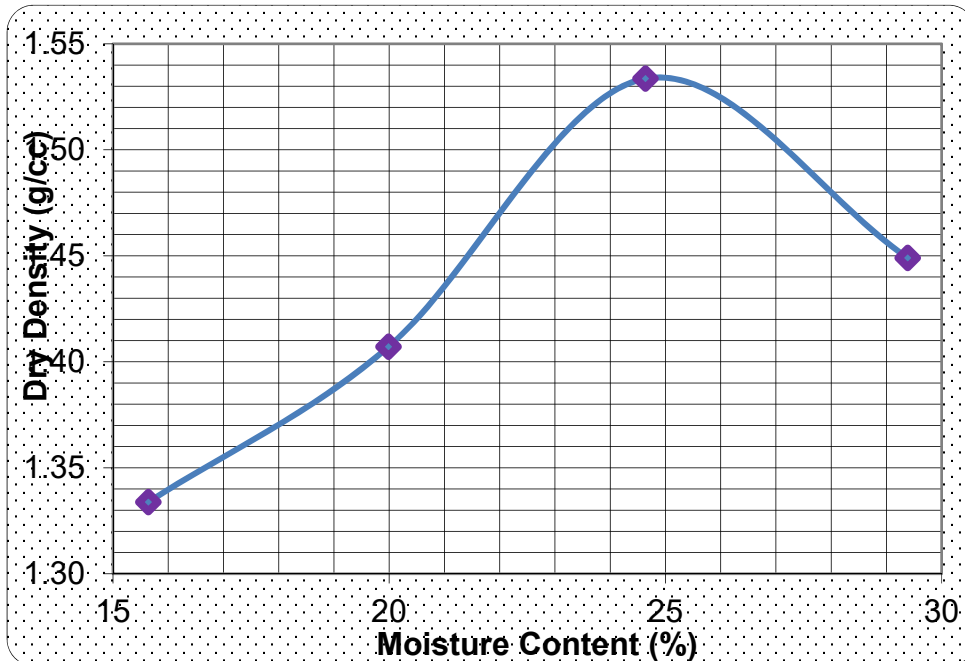

MDD (g/cc) 1.53

OMC (%) 24.6

Sample No. 2

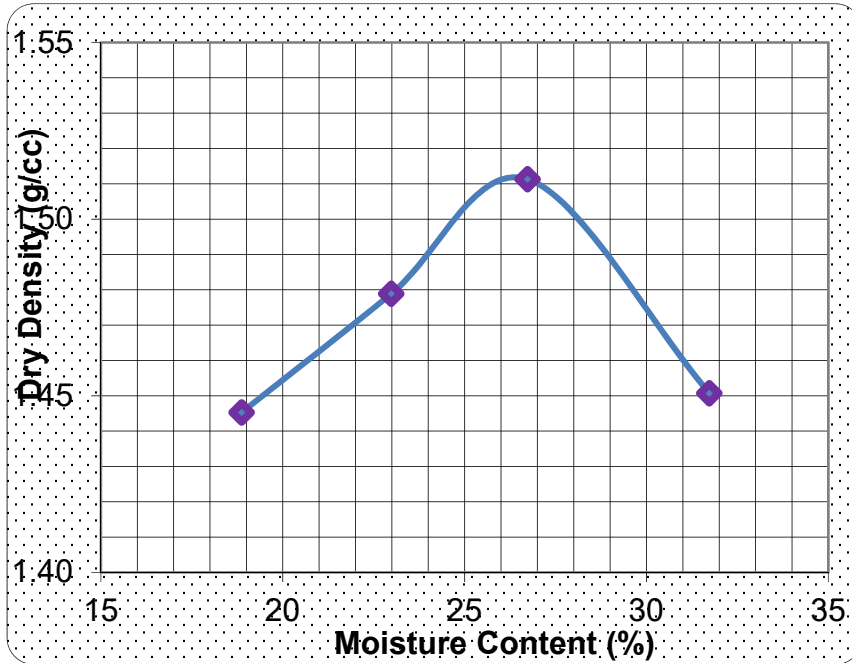

MDD(g/cc) 1.51

OMC (%) 26.7

Sample No. 3

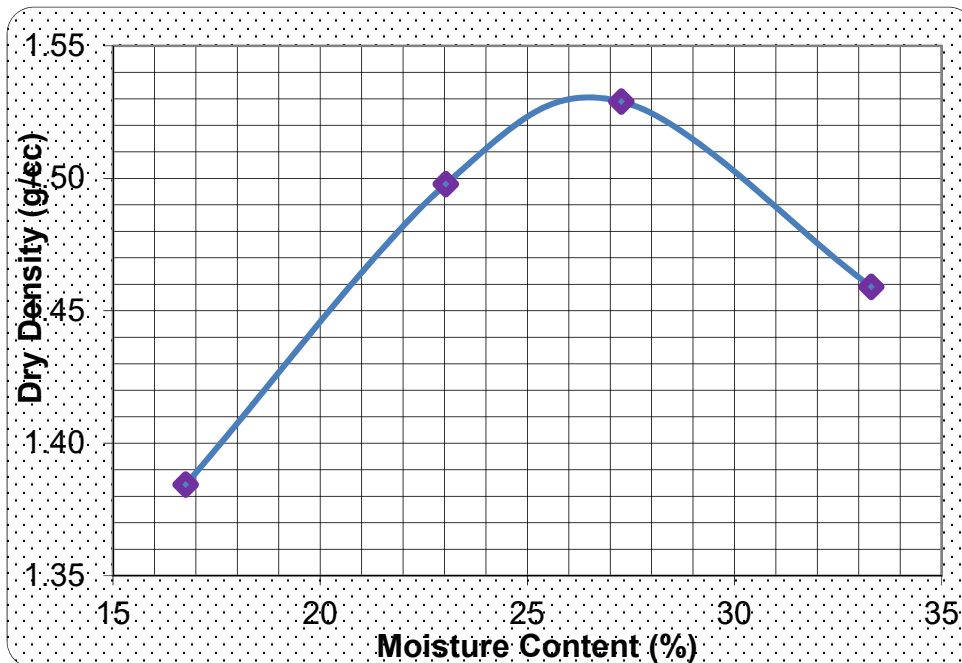

MDD (g/cc) 1.53

OMC (%) 26.5

Sample No. 4

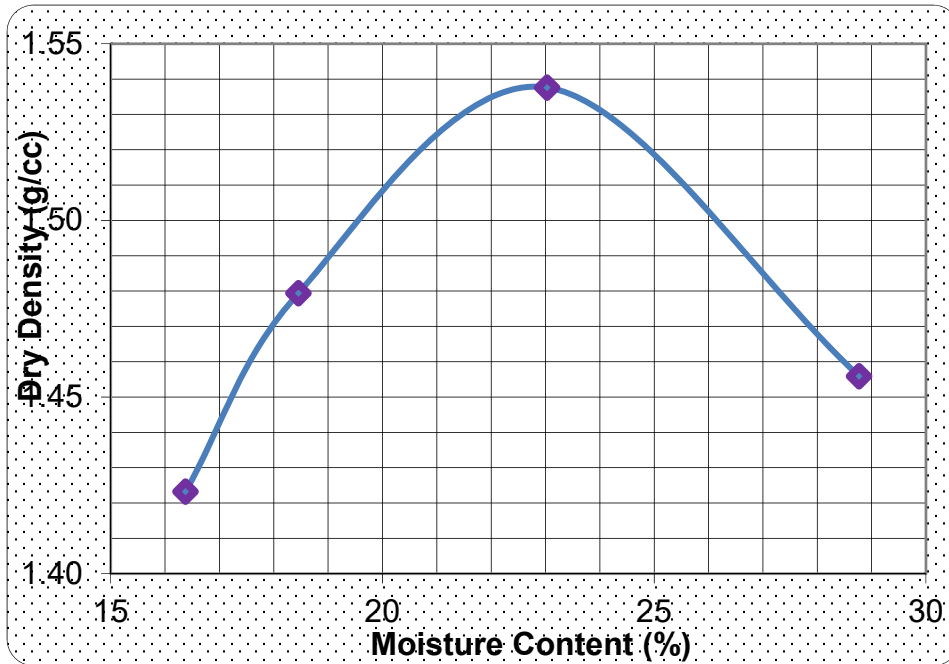

MDD (g/cc) 1.54

OMC (%) 23.0

Sample No. 5

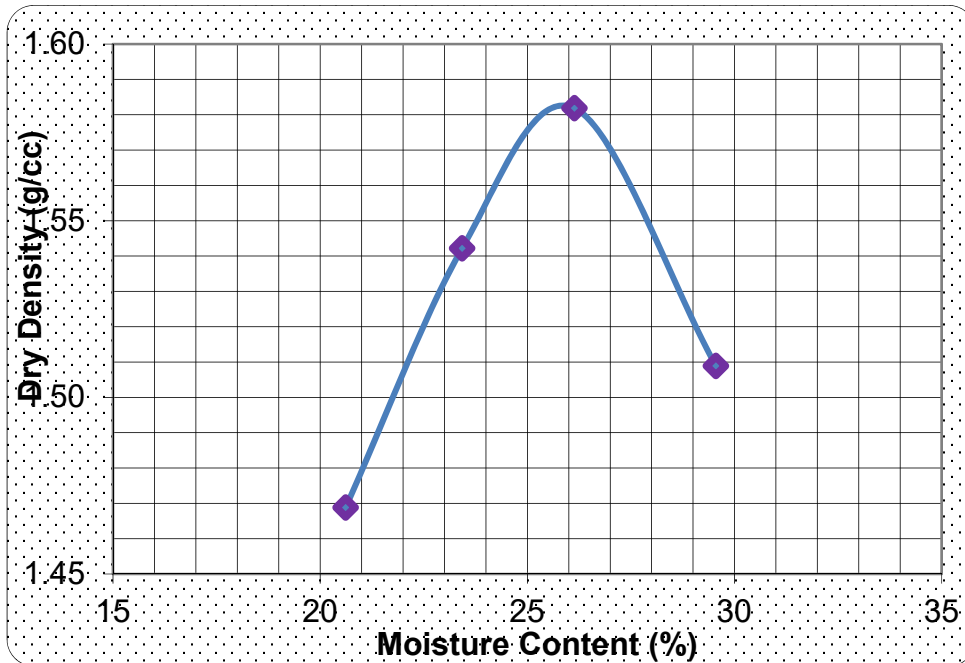

MDD (g/cc) 1.58

OMC (%) 25.8

Sample No. 6

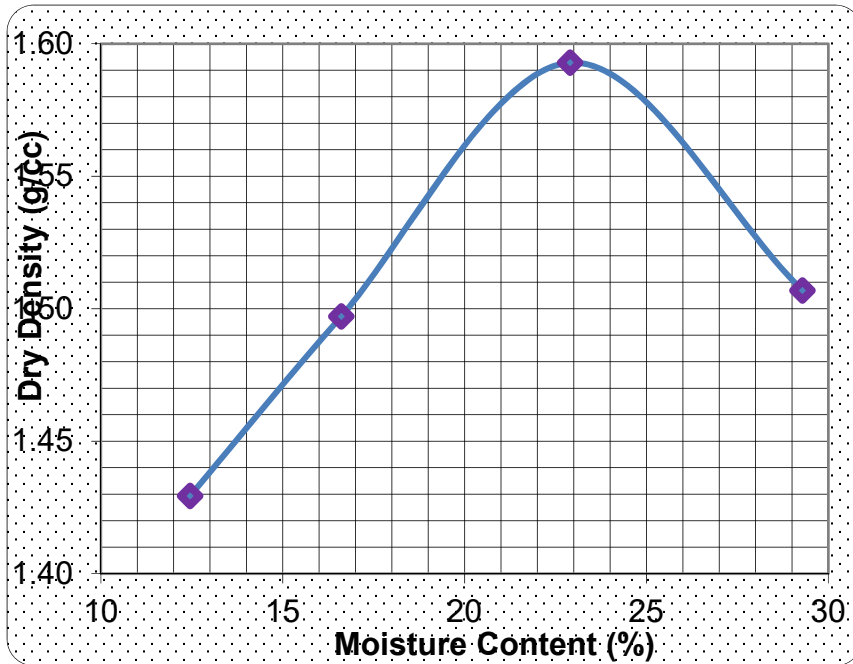

MDD (g/cc) 1.59

OMC (%) 22.9

Sample No. 7

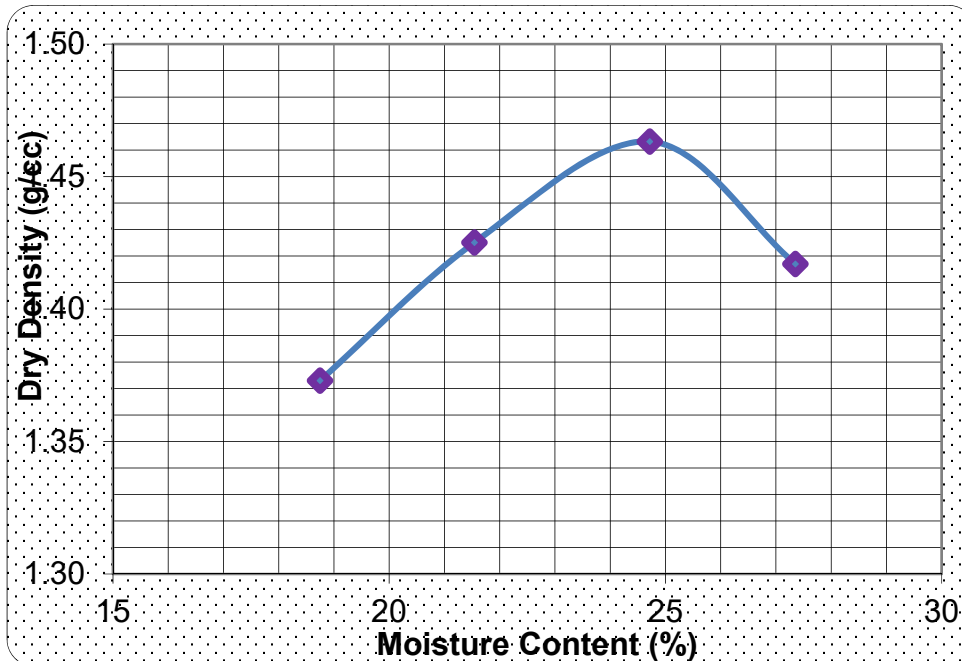

MDD (g/cc) 1.46

OMC (%) 24.7

Sample No. 8

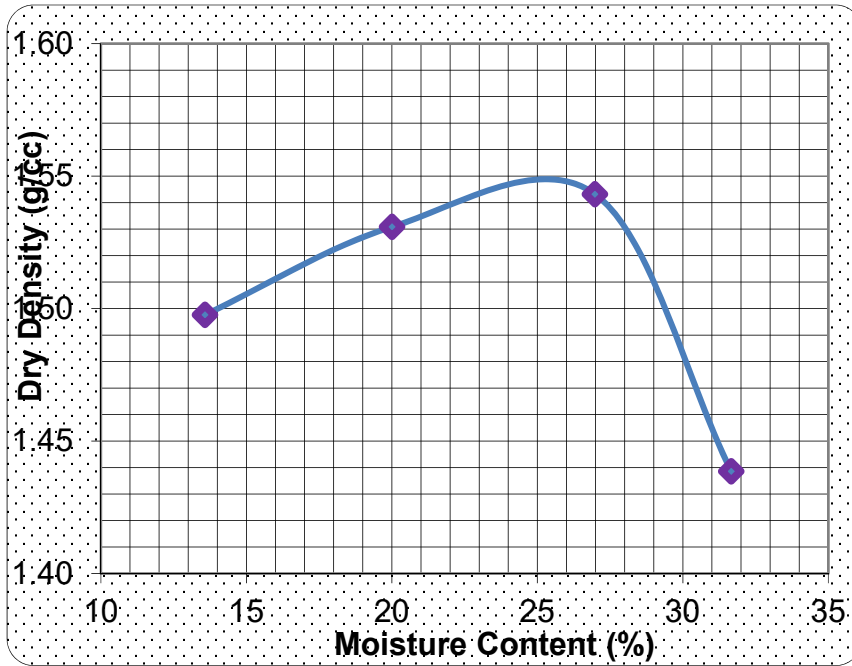

MDD (g/cc) 1.55

OMC (%) 25.0

Sample No. 9

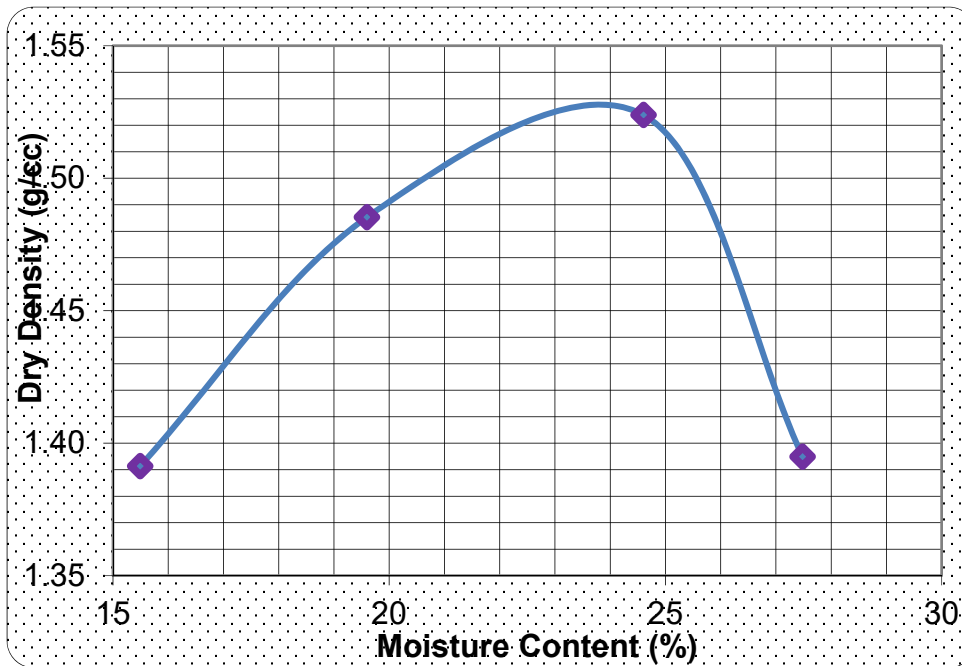

MDD (g/cc) 1.53

OMC (%) 24.0

Sample No. 10

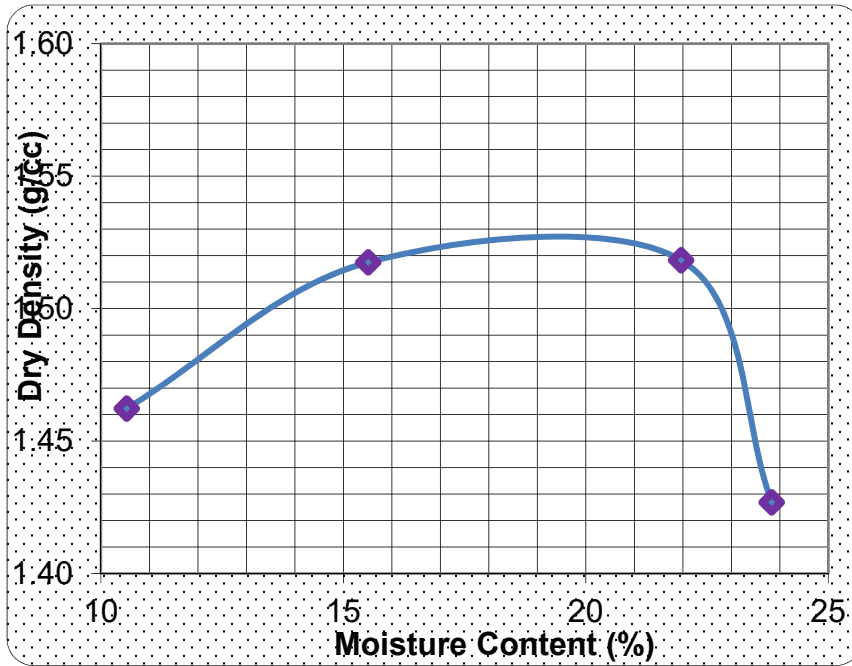

MDD (g/cc) 1.53

OMC (%) 19.8

Sample No. 11

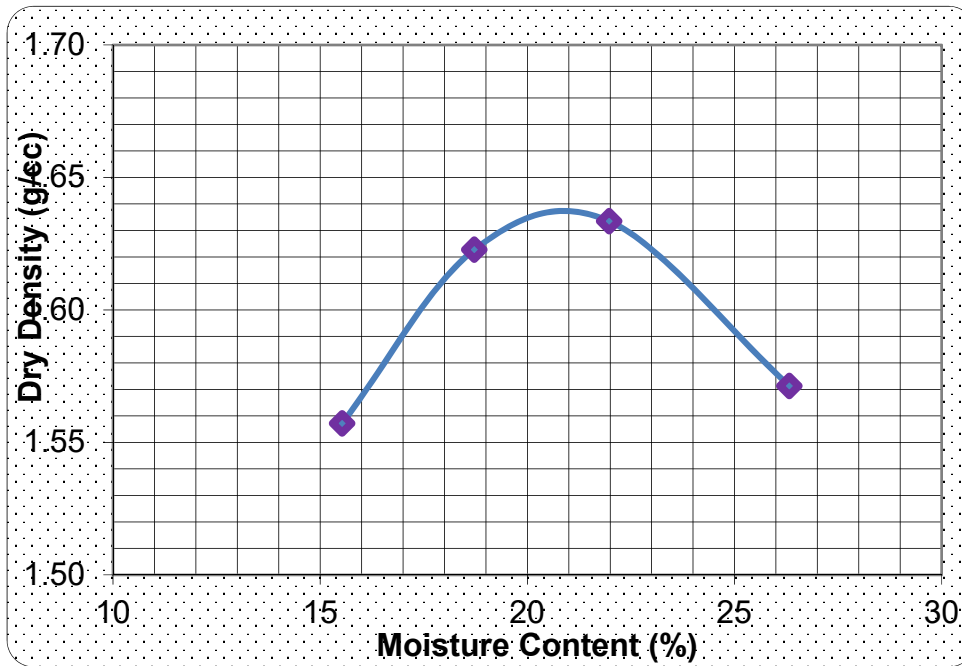

MDD (g/cc) 1.63

OMC (%) 21.0

Sample No. 12

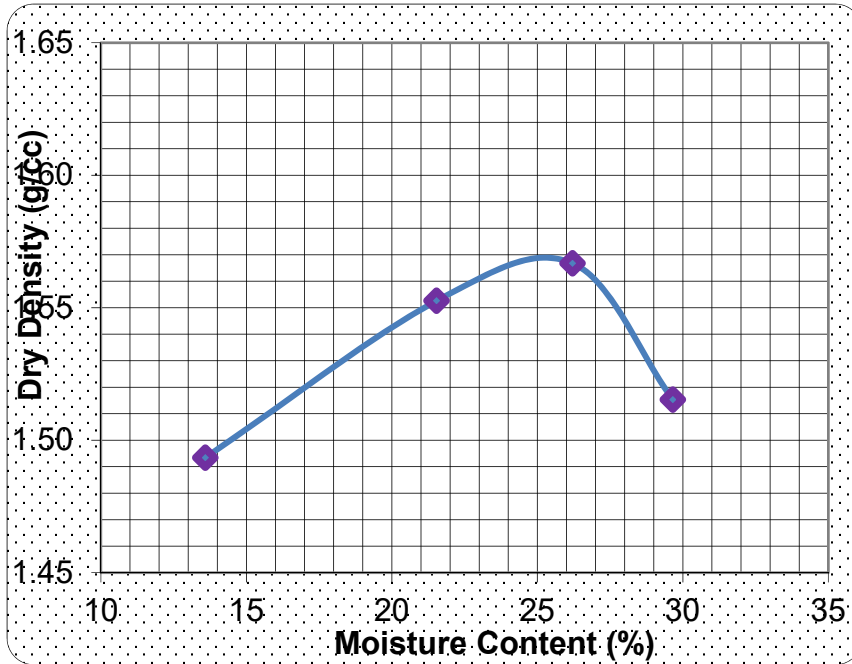

MDD (g/cc) 1.57

OMC (%) 25.0

Sample No. 13

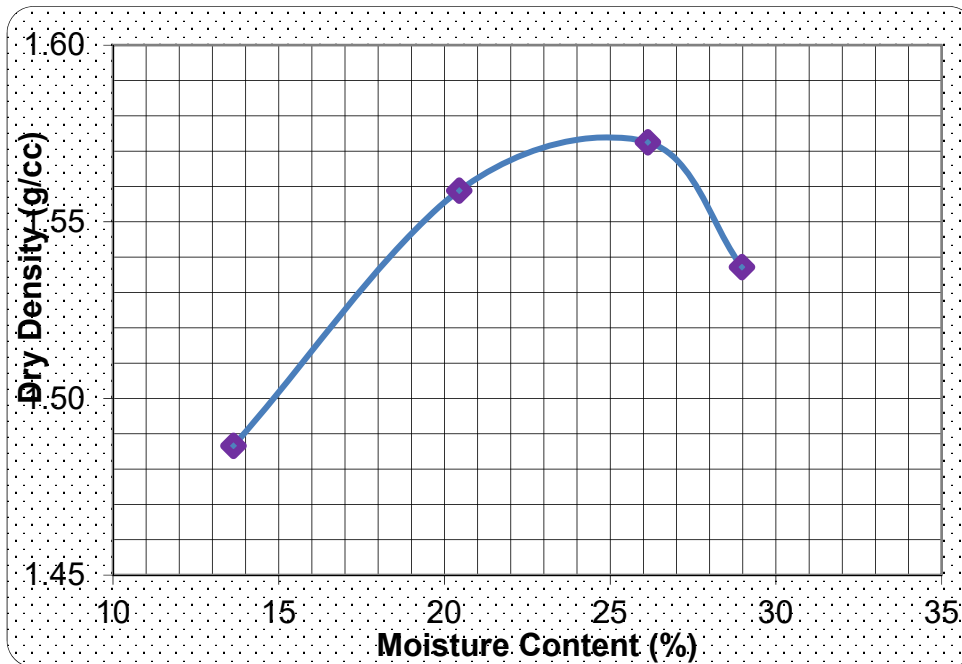

MDD (g/cc) 1.57

OMC (%) 25.0

Sample No. 14

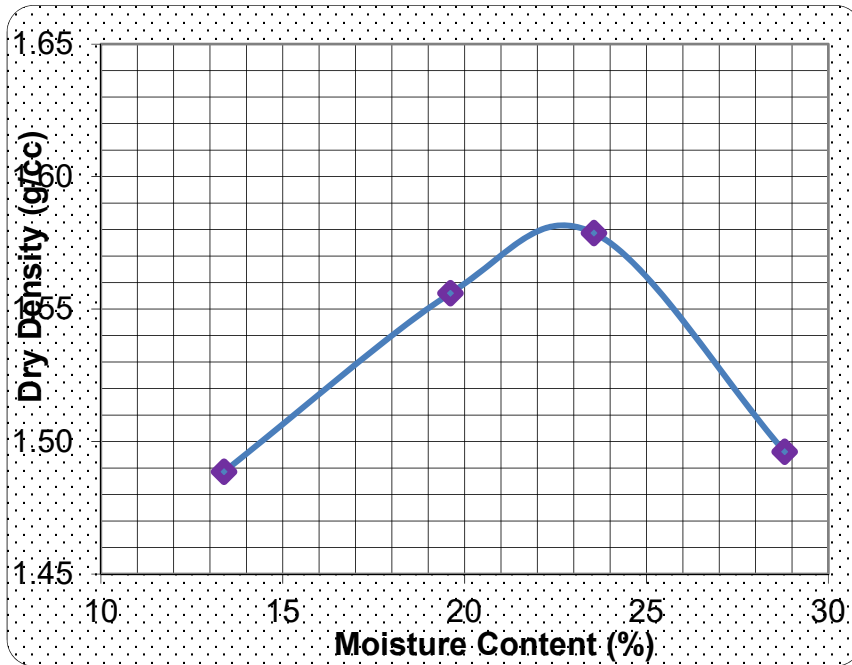

MDD(g/cc) 1.58

OMC (%) 23.0

Sample No. 15

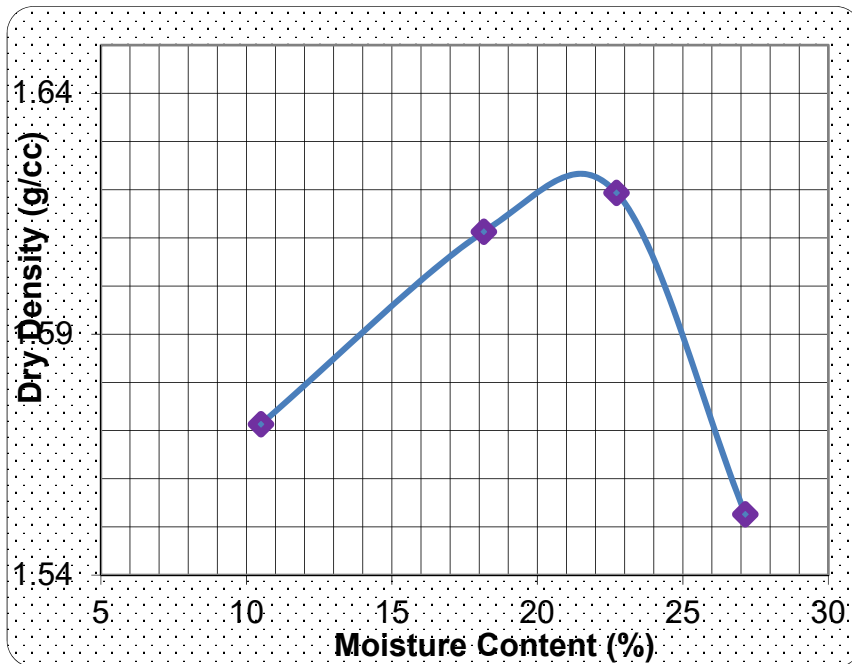

MDD (g/cc) 1.62

OMC (%) 21.5

Sample No. 17

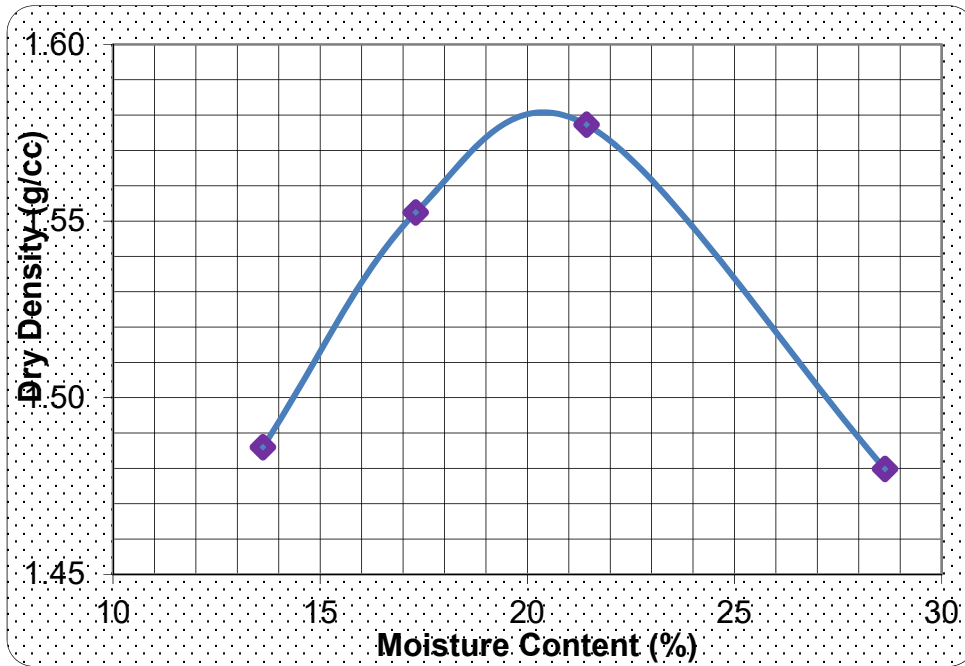

MDD (g/cc) 1.58

OMC (%) 21.4

Sample No. 18

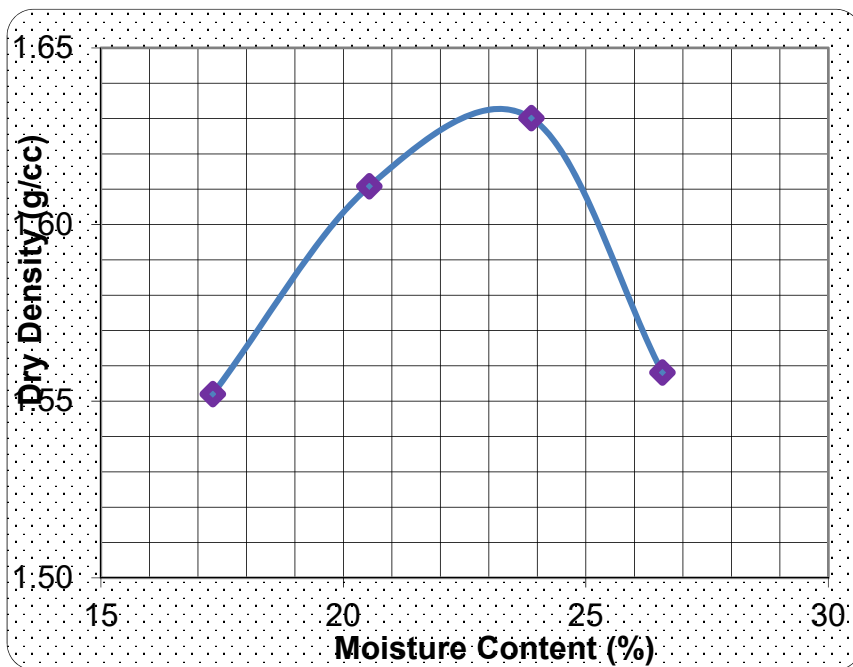

MDD (g/cc) 1.63

OMC (%) 23.4

Sample No. 19

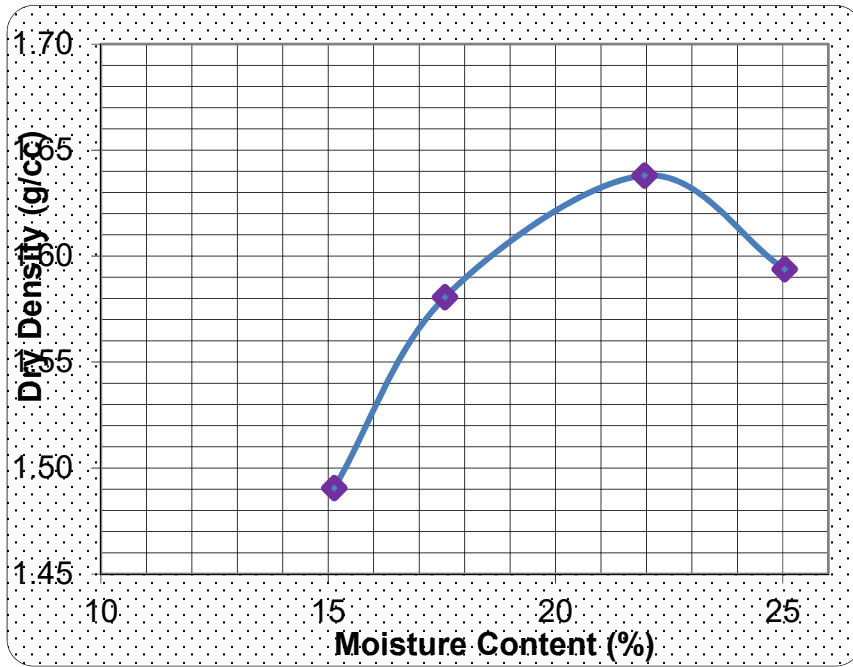

MDD (g/cc) 1.64

OMC (%) 22.2

Sample No. 21

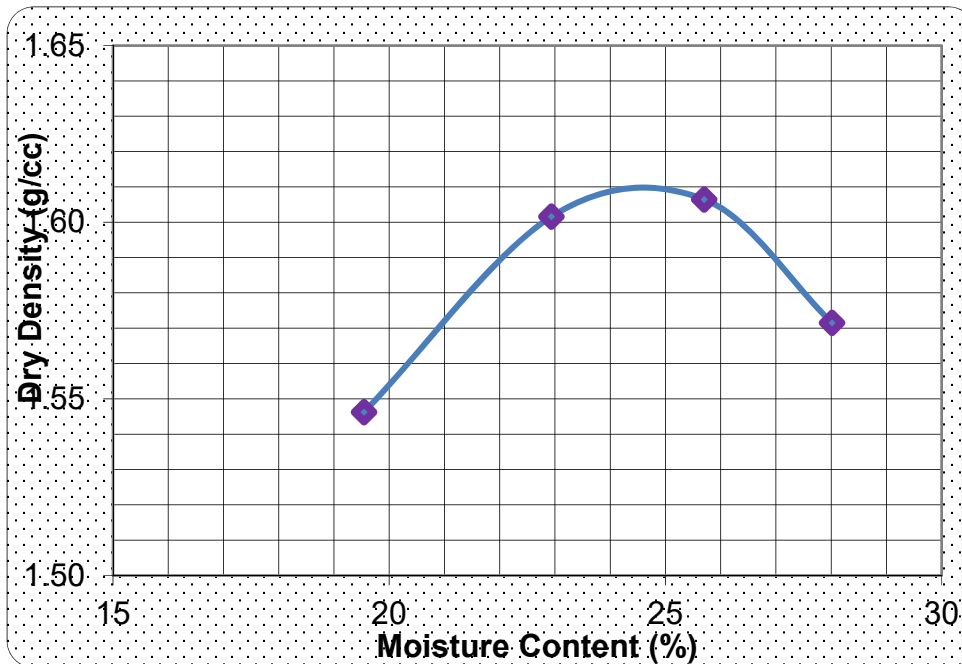

MDD (g/cc) 1.61

OMC (%) 24.5

Sample No. 22

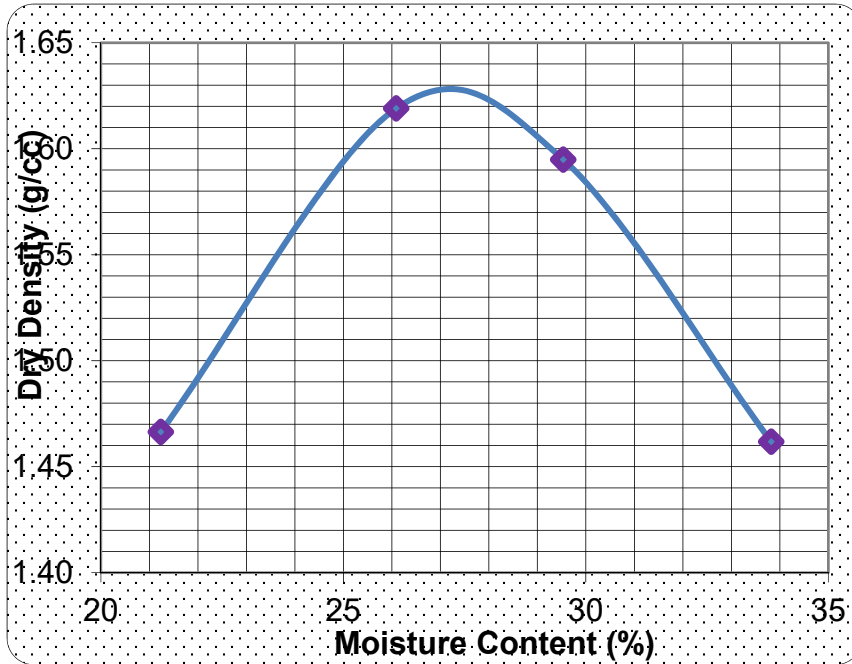

MDD (g/cc) 1.63

OMC (%) 27.4

Sample No. 29

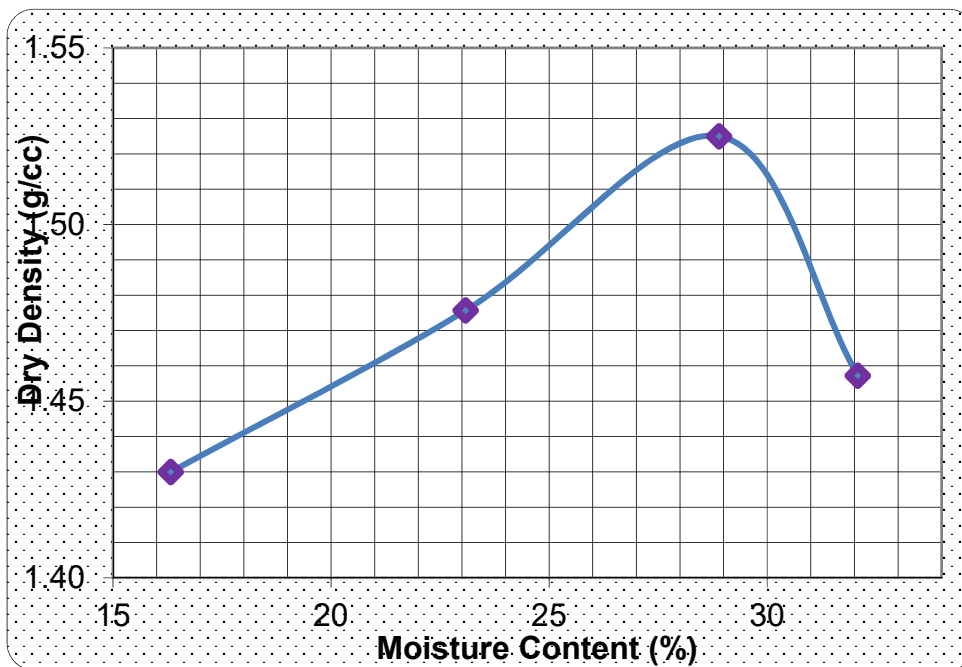

MDD (g/cc) 1.53

OMC (%) 28.5

Sample No. 30

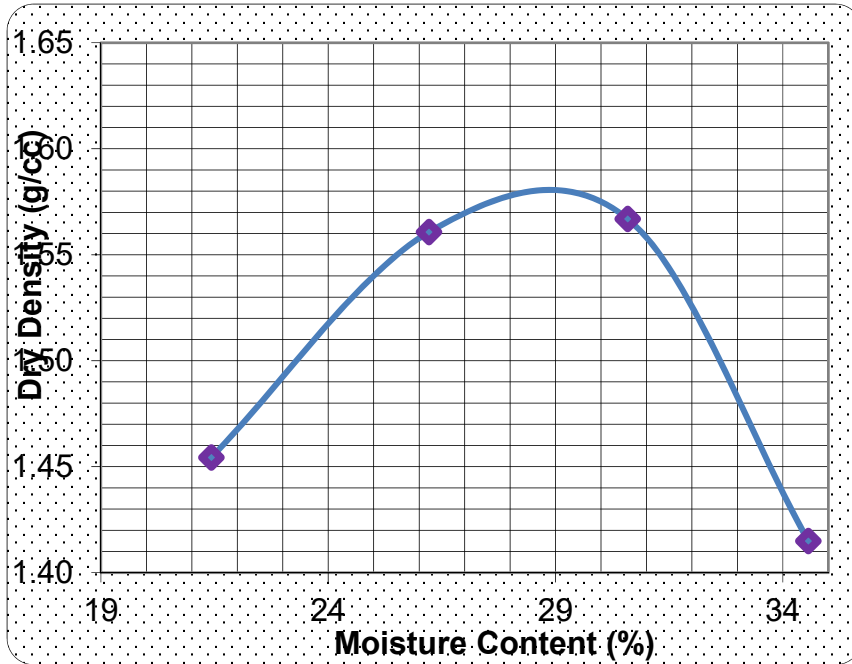

Sample No. 33

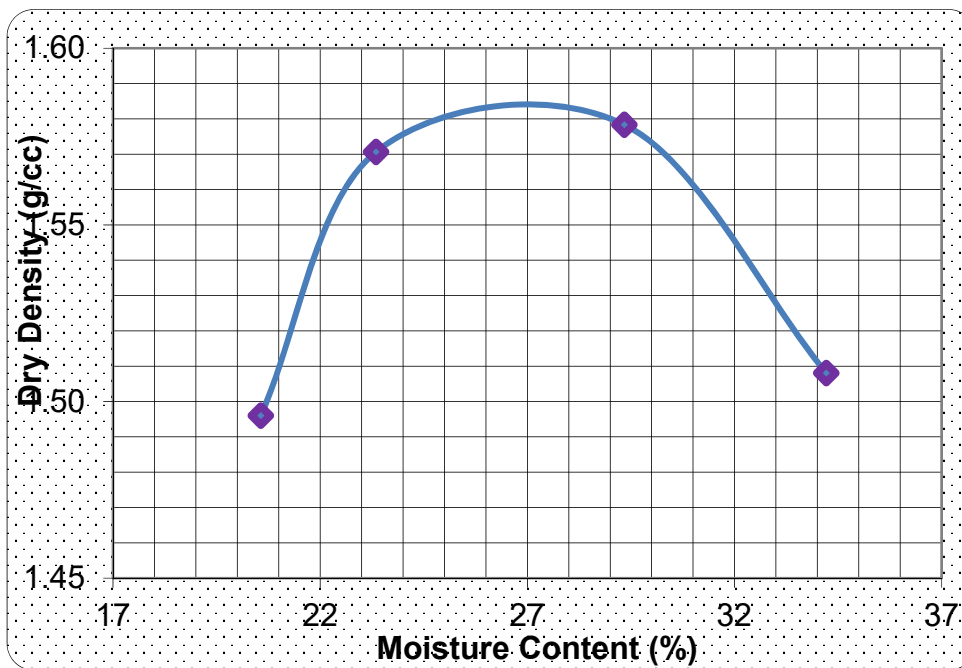

Sample No. 34

APPENDIX D – PARTICLE SIZE ANALYSIS

Sample No. 1

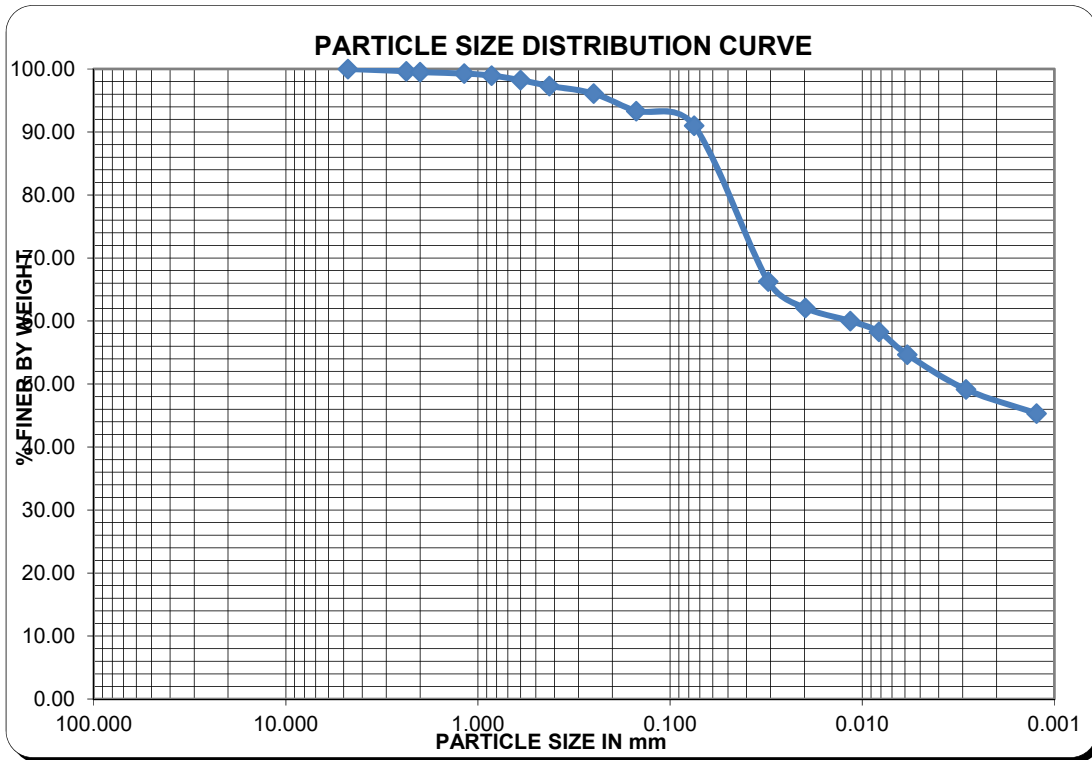

SIZE PROPORTIONS

Particle larger than 2.00 mm, % 0.5

Sand (2.00mm-0.075mm), % 8.5

Silt (0.075mm-0.002mm), % 45.7

Clay (less than 0.002), % 45.3

Sample No. 2

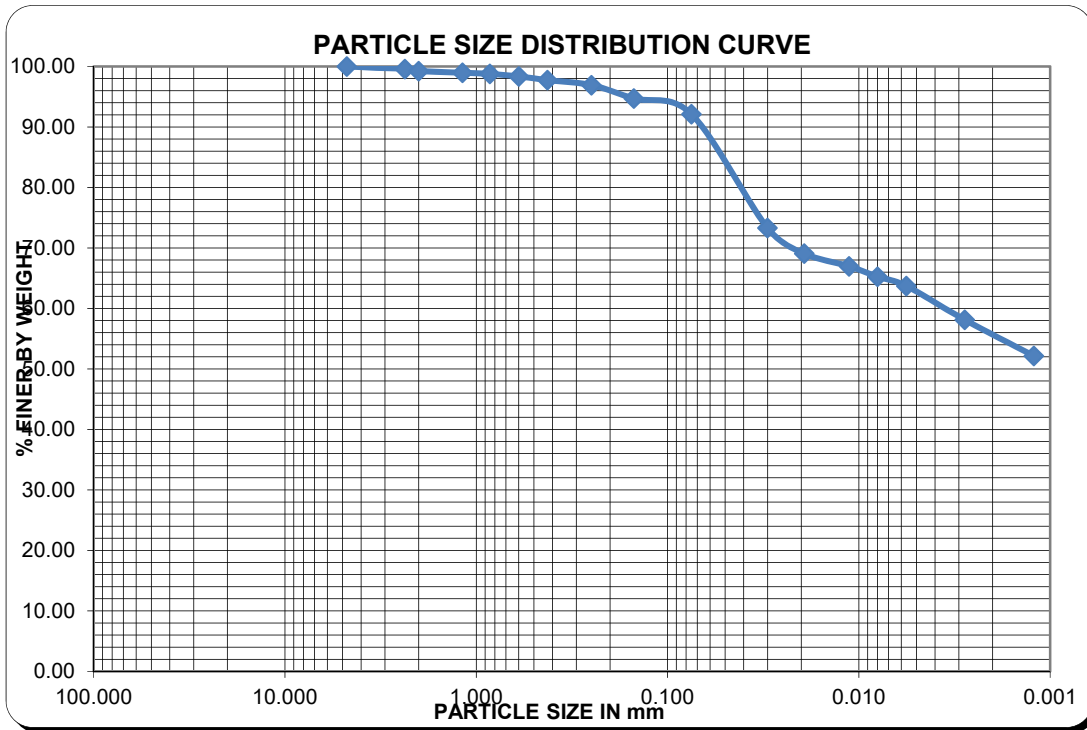

SIZE PROPORTIONS

Particle larger than 2.00 mm, %	<u>0.8</u>
Sand (2.00mm-0.075mm), %	<u>7.1</u>
Silt (0.075mm-0.002mm), %	<u>40.0</u>
Clay (less than 0.002), %	<u>52.2</u>

Sample No. 3

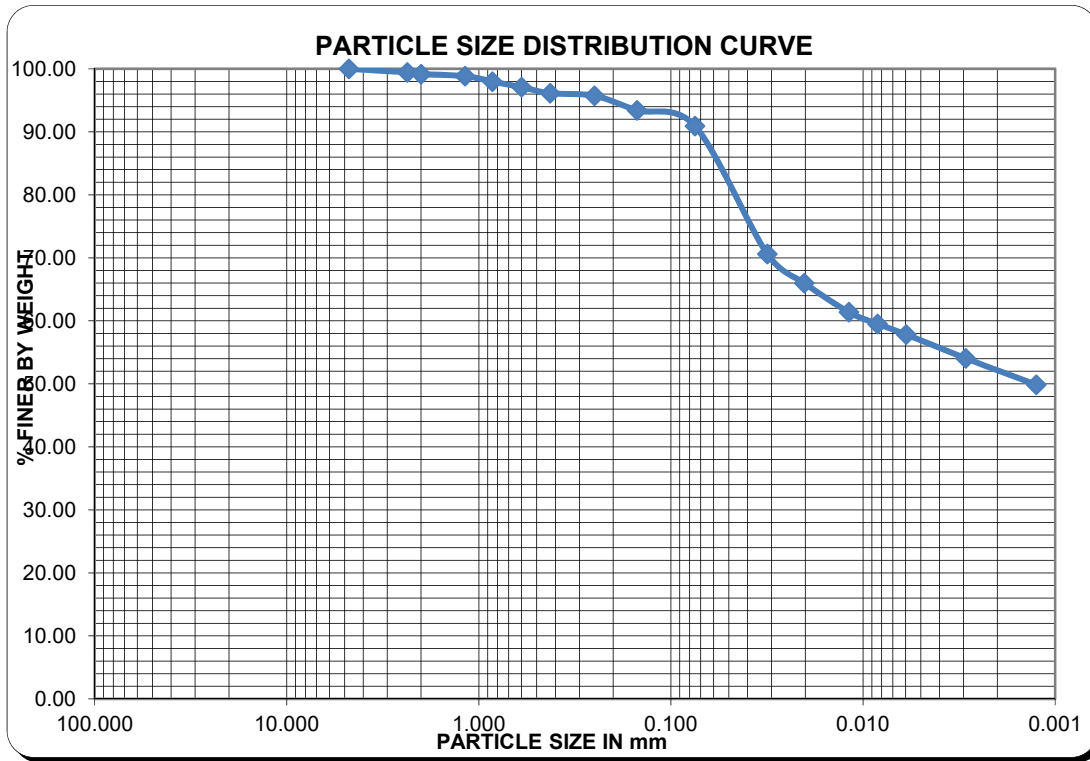

SIZE PROPORTIONS

Particle larger than 2.00 mm, % 0.8

Sand (2.00mm-0.075mm), % 8.2

Silt (0.075mm-0.002mm), % 41.1

Clay (less than 0.002), % 49.9

Sample No. 4

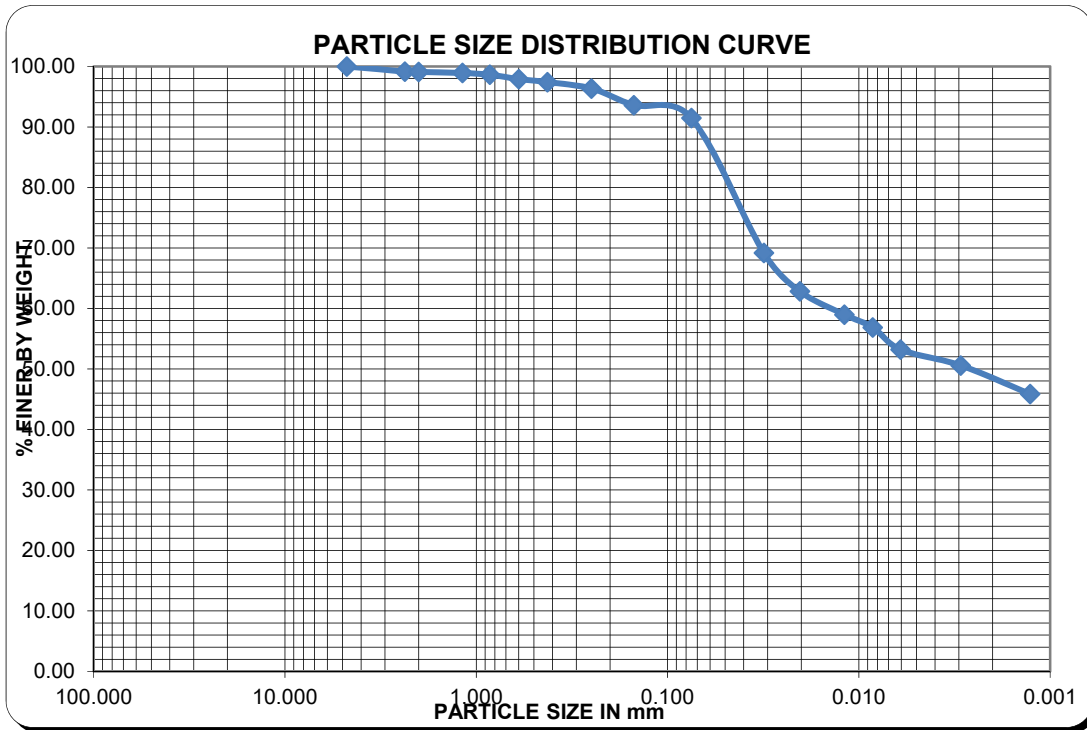

SIZE PROPORTIONS

Particle larger than 2.00 mm, %	<u>0.9</u>
Sand (2.00mm-0.075mm), %	<u>7.6</u>
Silt (0.075mm-0.002mm), %	<u>45.6</u>
Clay (less than 0.002), %	<u>45.9</u>

Sample No. 5

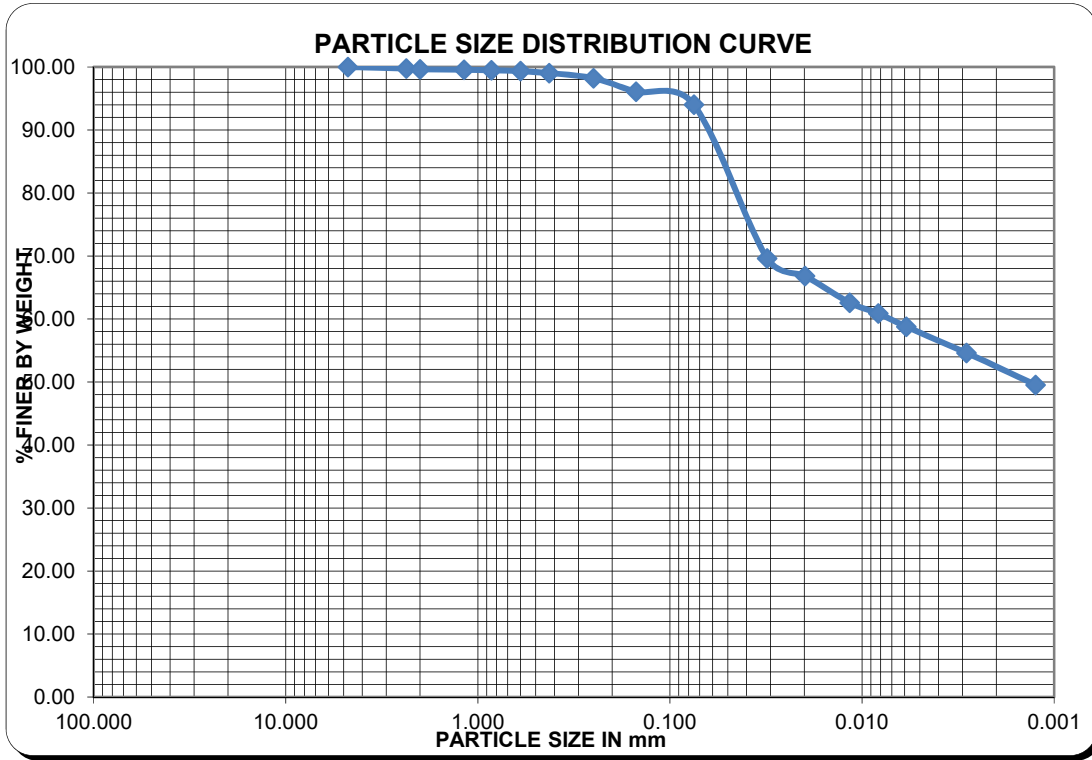

SIZE PROPORTIONS

Particle larger than 2.00 mm, % 0.4

Sand (2.00mm-0.075mm), % 5.6

Silt (0.075mm-0.002mm), % 44.5

Clay (less than 0.002), % 49.5

Sample No. 6

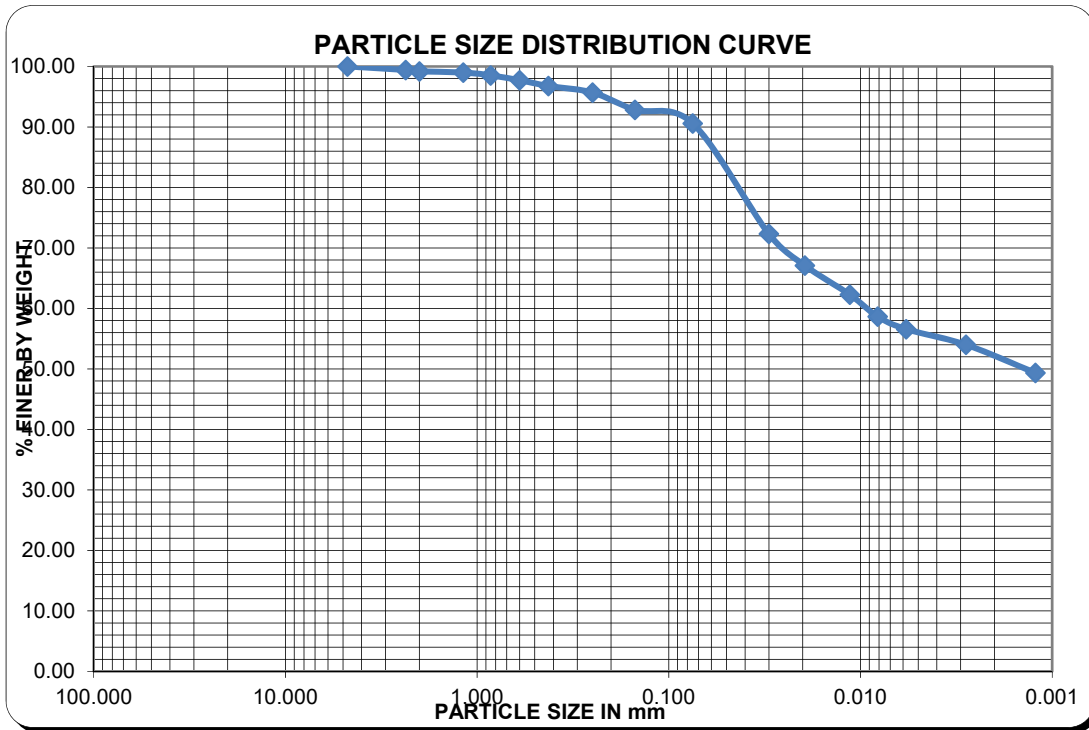

SIZE PROPORTIONS

Particle larger than 2.00 mm, % 0.8

Sand (2.00mm-0.075mm), % 8.6

Silt (0.075mm-0.002mm), % 41.2

Clay (less than 0.002), % 49.4

Sample No. 7

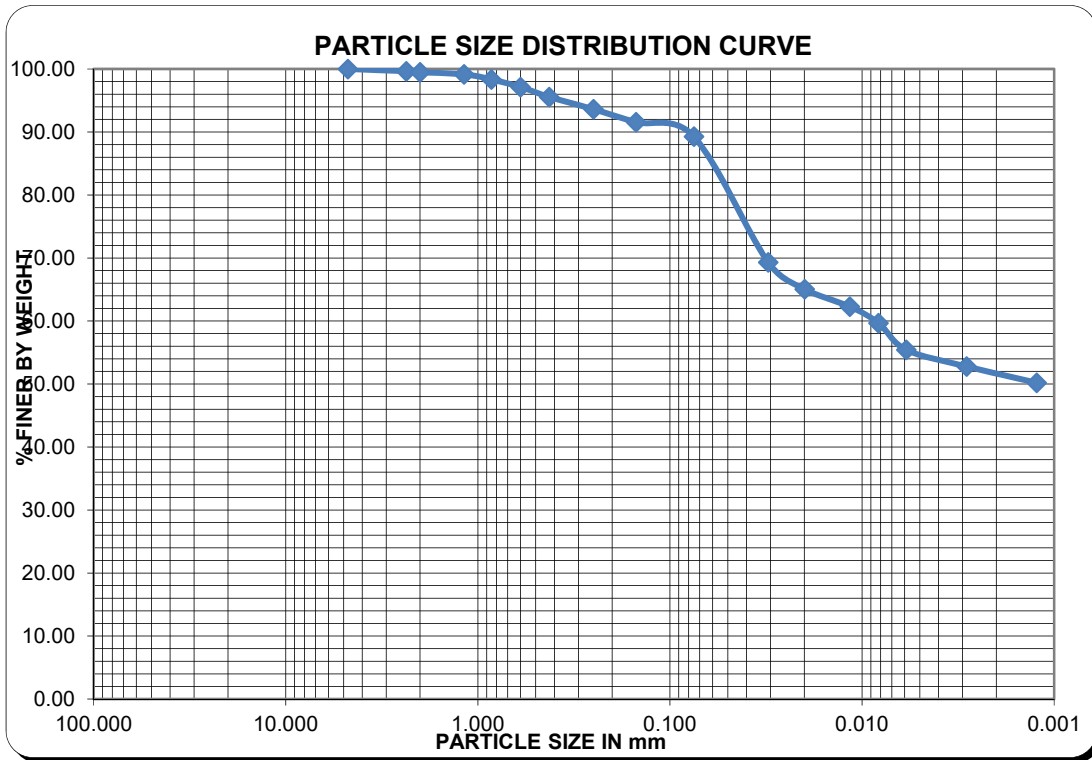

SIZE PROPORTIONS

Particle larger than 2.00 mm, % 0.5

Sand (2.00mm-0.075mm), % 10.2

Silt (0.075mm-0.002mm), % 39.1

Clay (less than 0.002), % 50.2

Sample No. 8

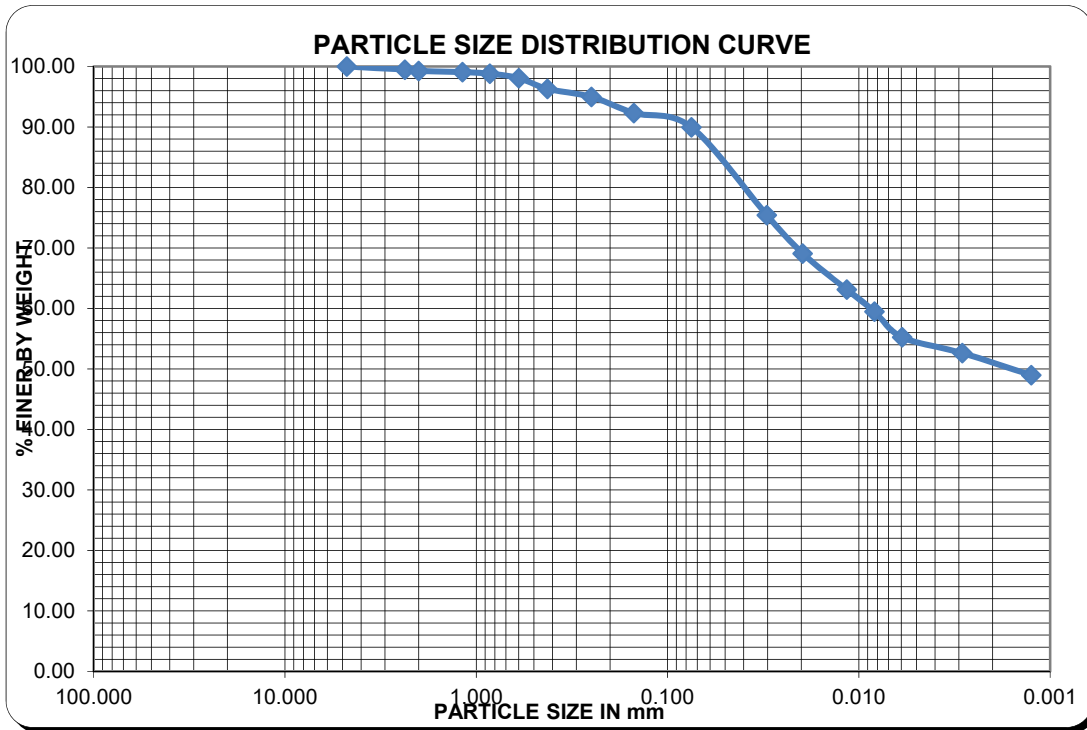

SIZE PROPORTIONS

Particle larger than 2.00 mm, %	<u>0.7</u>
Sand (2.00mm-0.075mm), %	<u>9.3</u>
Silt (0.075mm-0.002mm), %	<u>41.0</u>
Clay (less than 0.002), %	<u>49.0</u>

Sample No. 10

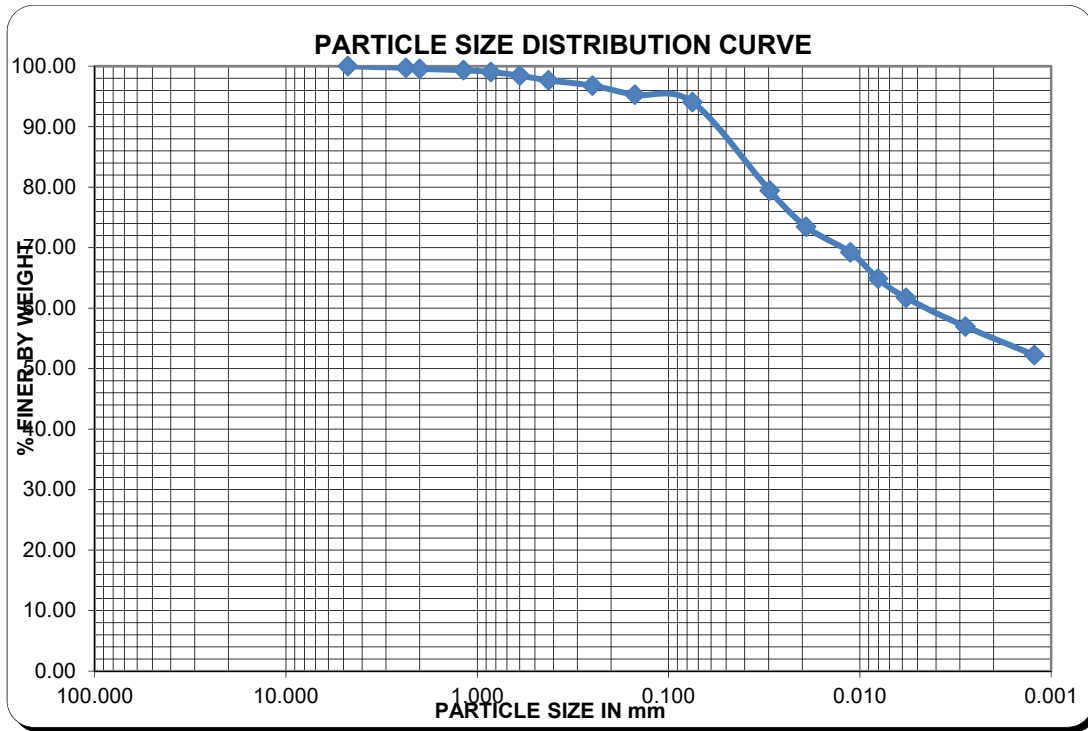

SIZE PROPORTIONS

Particle larger than 2.00 mm, % 0.4

Sand (2.00mm-0.075mm), % 5.5

Silt (0.075mm-0.002mm), % 41.8

Clay (less than 0.002), % 52.3

Sample No. 11

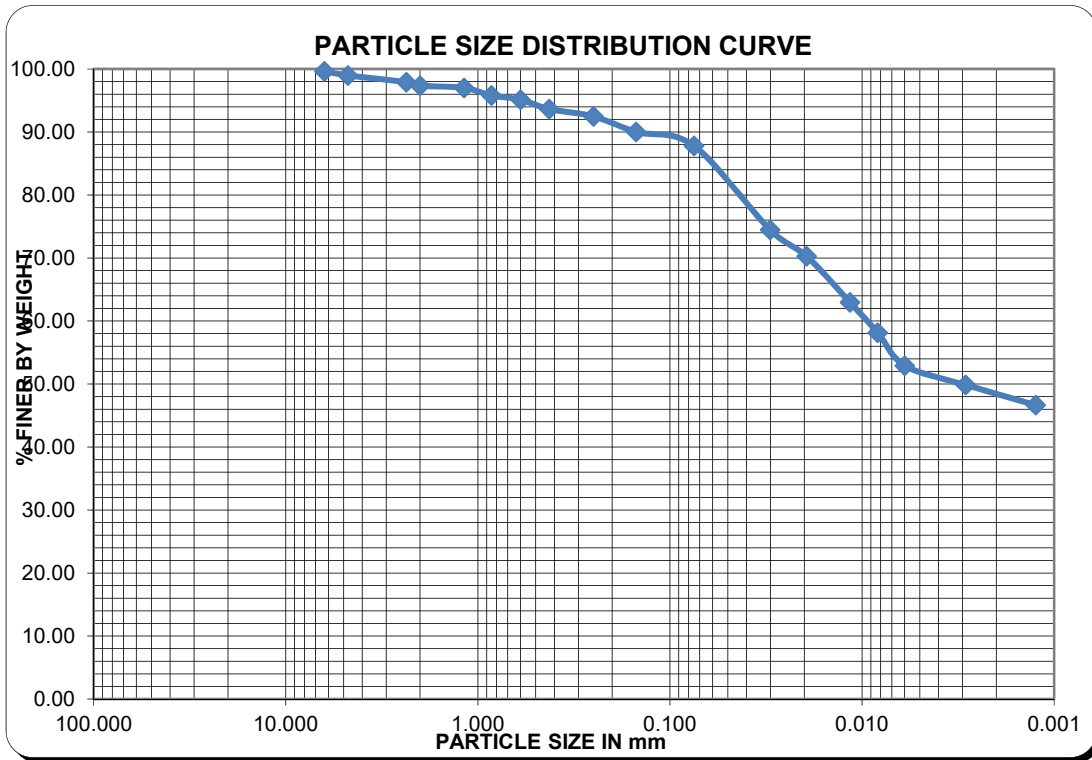

SIZE PROPORTIONS

Particle larger than 2.00 mm, % 2.6

Sand (2.00mm-0.075mm), % 9.5

Silt (0.075mm-0.002mm), % 41.1

Clay (less than 0.002), % 46.7

Sample No. 12

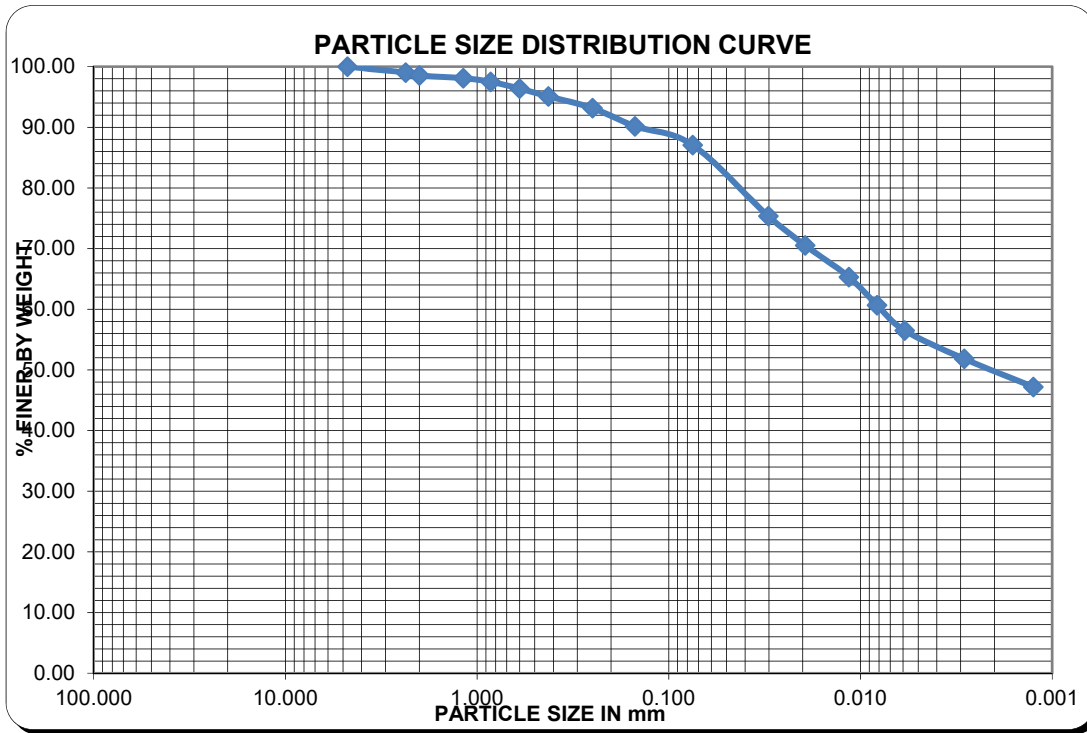

SIZE PROPORTIONS

Particle larger than 2.00 mm, % 1.5

Sand (2.00mm-0.075mm), % 11.5

Silt (0.075mm-0.002mm), % 39.9

Clay (less than 0.002), % 47.2

Sample No. 13

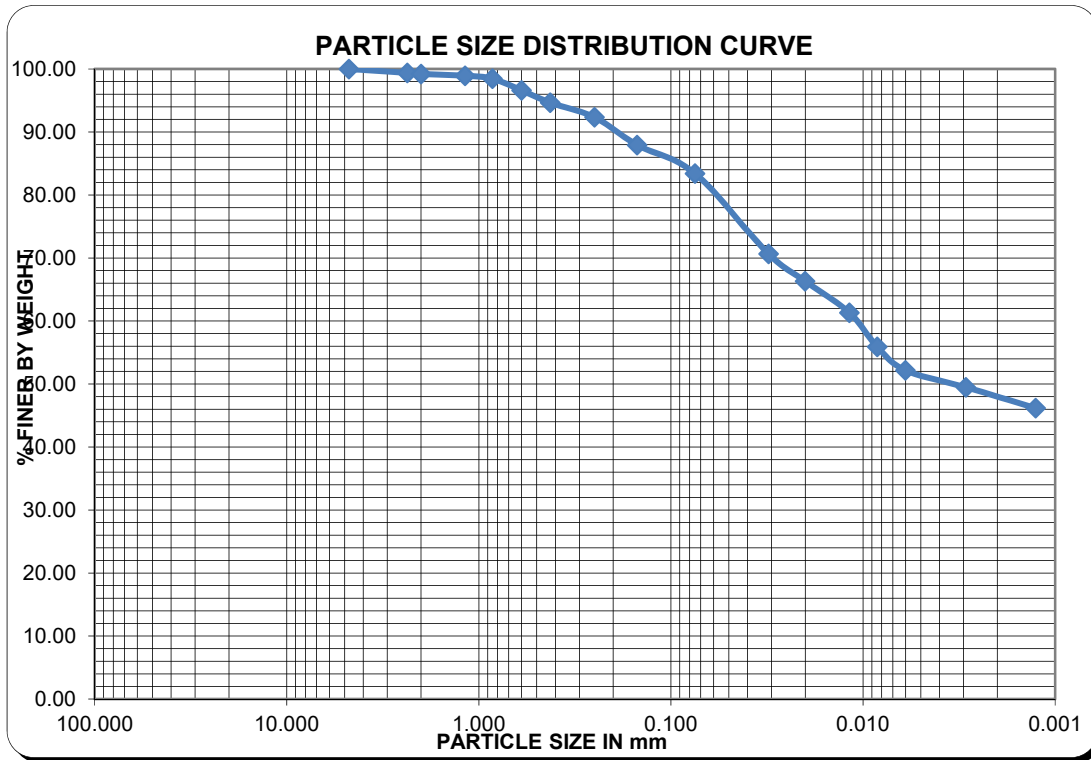

SIZE PROPORTIONS

Particle larger than 2.00 mm, % 0.8

Sand (2.00mm-0.075mm), % 15.8

Silt (0.075mm-0.002mm), % 37.2

Clay (less than 0.002), % 46.2

Sample No. 14

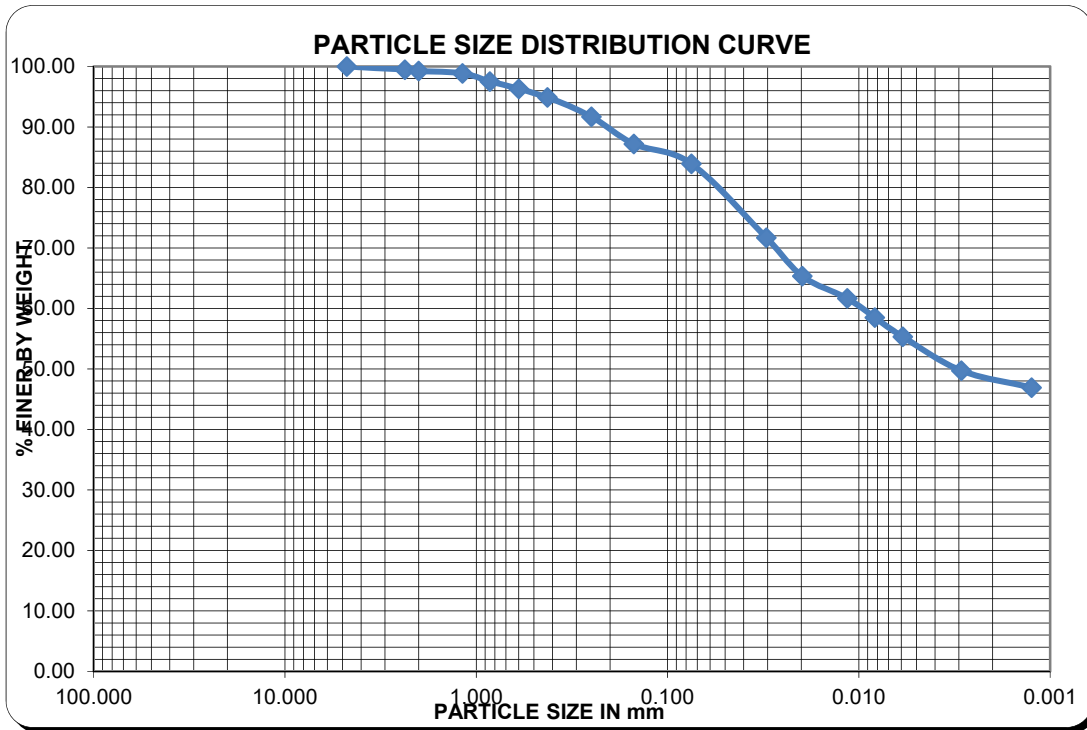

SIZE PROPORTIONS

Particle larger than 2.00 mm, %	<u>0.7</u>
Sand (2.00mm-0.075mm), %	<u>15.3</u>
Silt (0.075mm-0.002mm), %	<u>37.0</u>
Clay (less than 0.002), %	<u>46.9</u>

Sample No. 17

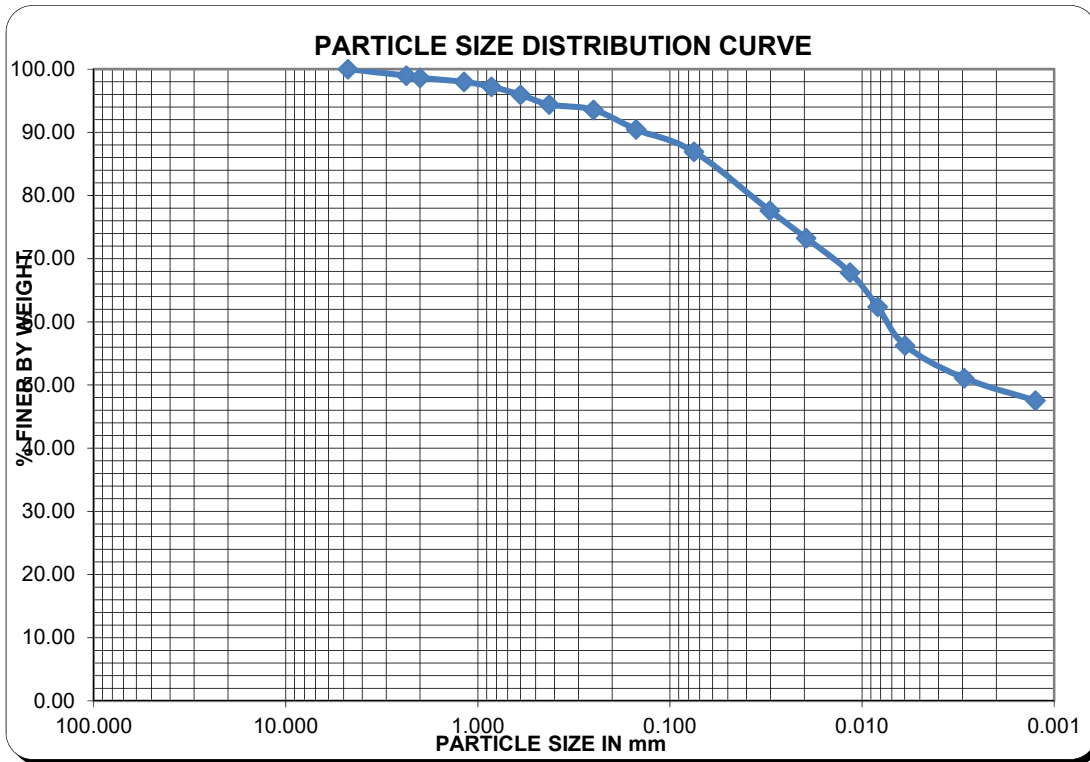

SIZE PROPORTIONS

Particle larger than 2.00 mm, % 1.4

Sand (2.00mm-0.075mm), % 11.7

Silt (0.075mm-0.002mm), % 39.4

Clay (less than 0.002), % 47.5

Sample No. 18

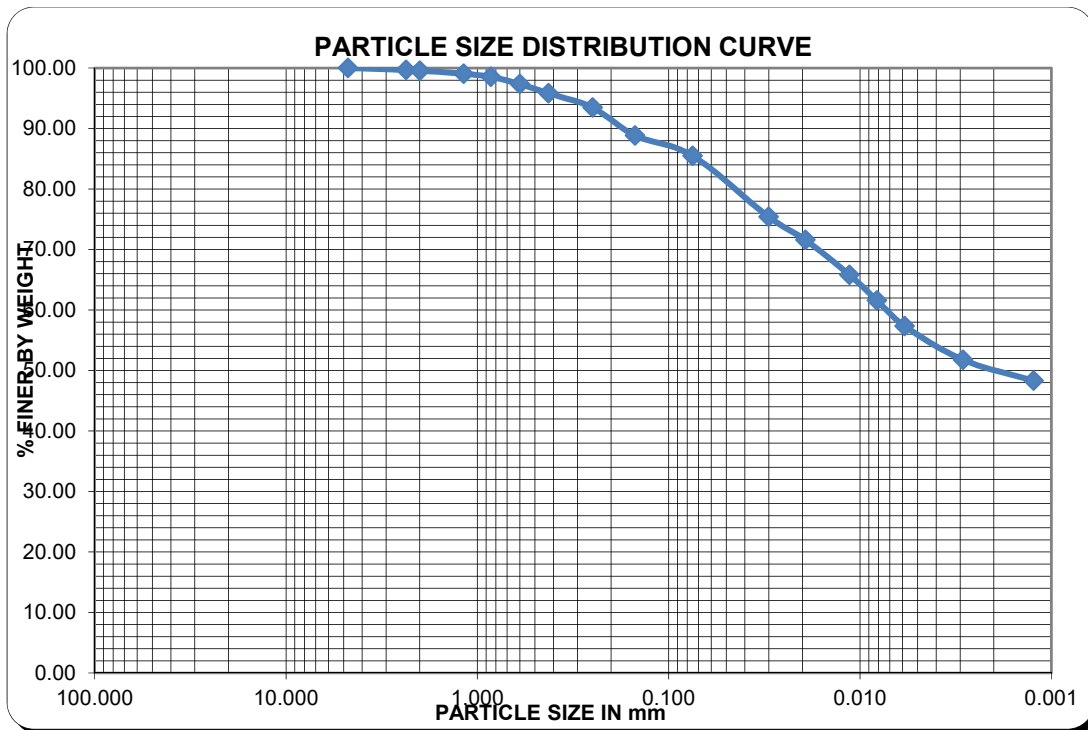

SIZE PROPORTIONS

Particle larger than 2.00 mm, % 0.4

Sand (2.00mm-0.075mm), % 14.1

Silt (0.075mm-0.002mm), % 37.2

Clay (less than 0.002), % 48.3

Sample No. 19

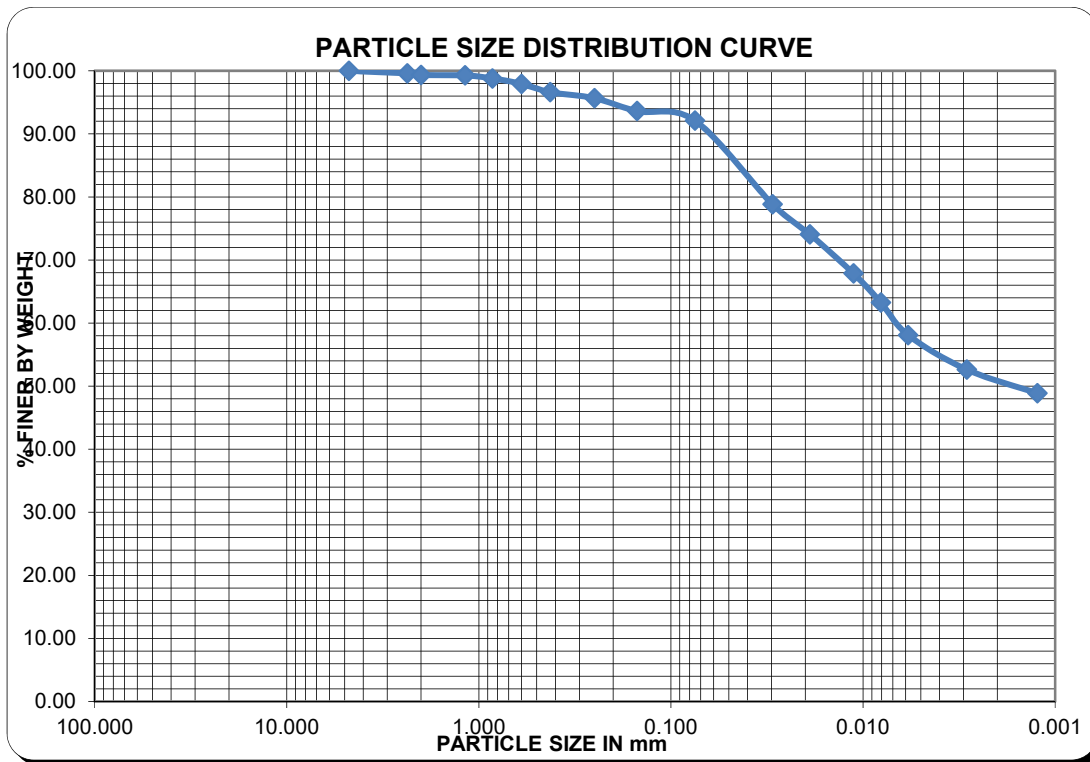

SIZE PROPORTIONS

Particle larger than 2.00 mm, % 0.7

Sand (2.00mm-0.075mm), % 7.2

Silt (0.075mm-0.002mm), % 43.2

Clay (less than 0.002), % 48.9

Sample No. 21

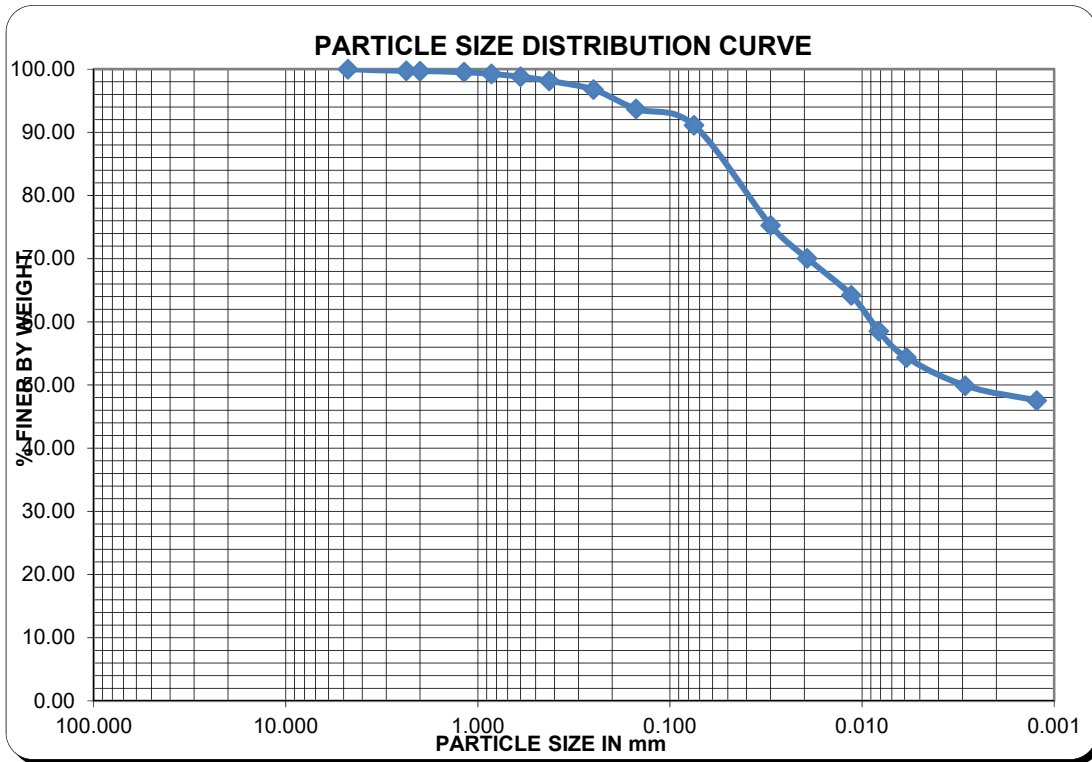

SIZE PROPORTIONS

Particle larger than 2.00 mm, % 0.3

Sand (2.00mm-0.075mm), % 8.6

Silt (0.075mm-0.002mm), % 43.6

Clay (less than 0.002), % 47.6

Sample No. 22

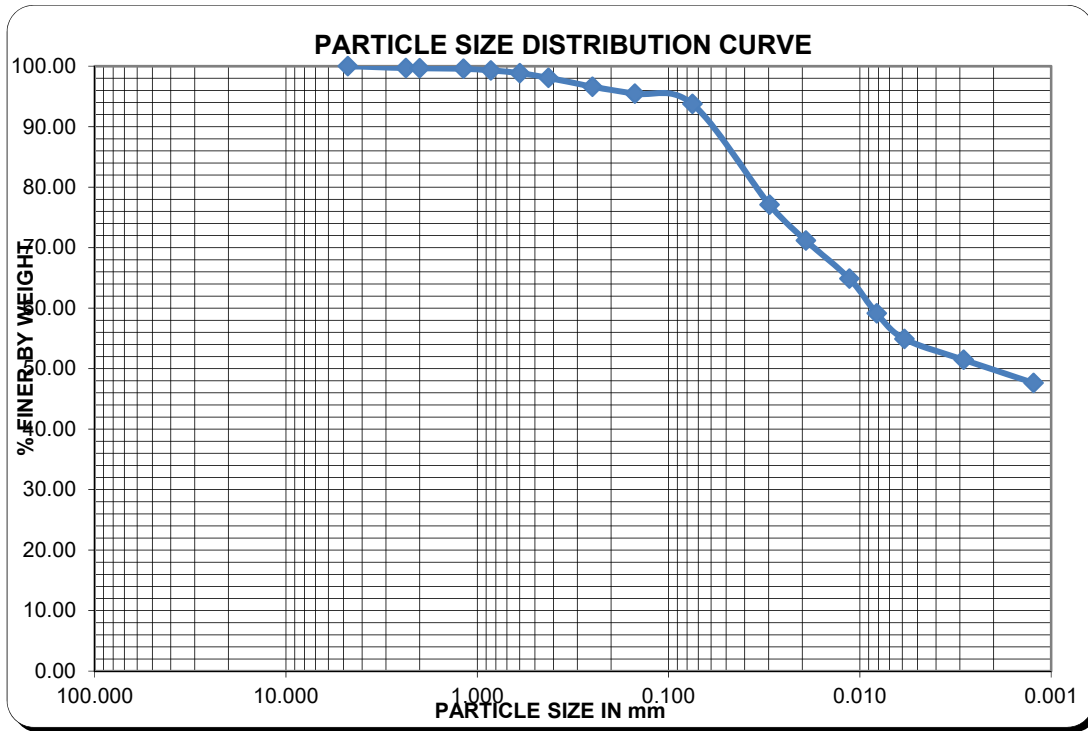

SIZE PROPORTIONS

Particle larger than 2.00 mm, % 0.3

Sand (2.00mm-0.075mm), % 5.9

Silt (0.075mm-0.002mm), % 46.1

Clay (less than 0.002), % 47.6

Sample No. 30

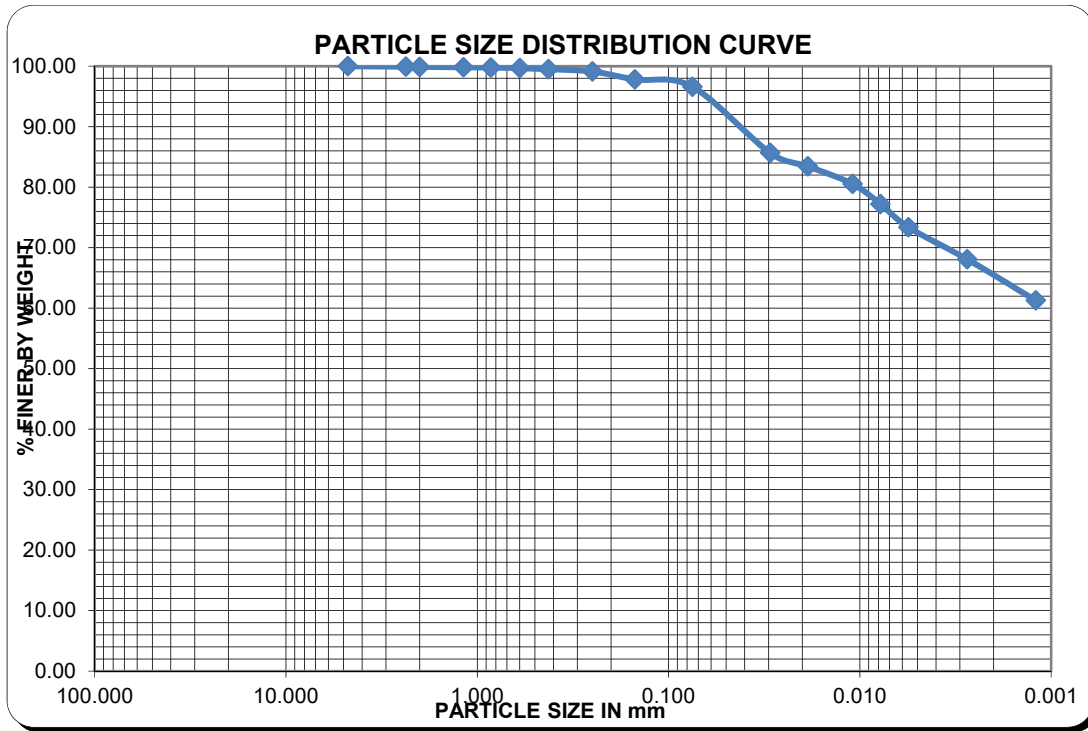

SIZE PROPORTIONS

Particle larger than 2.00 mm, % 0.1

Sand (2.00mm-0.075mm), % 3.3

Silt (0.075mm-0.002mm), % 35.3

Clay (less than 0.002), % 61.3

Sample No. 33

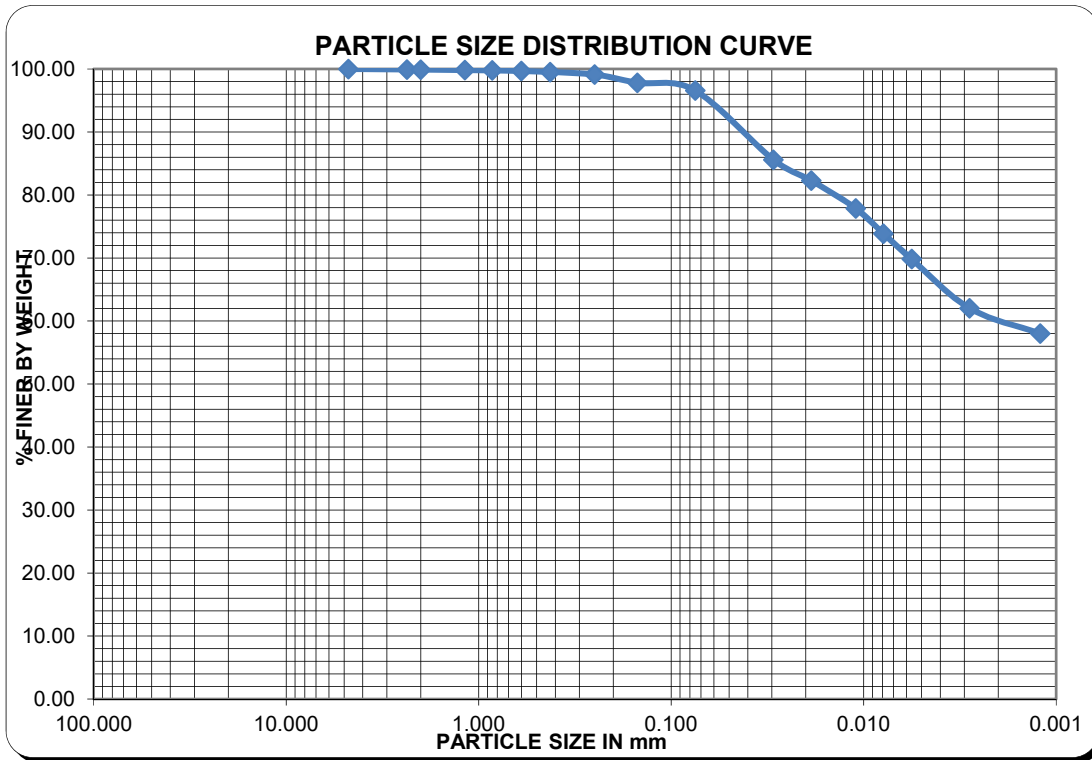

SIZE PROPORTIONS

Particle larger than 2.00 mm, % 0.1

Sand (2.00mm-0.075mm), % 3.3

Silt (0.075mm-0.002mm), % 38.6

Clay (less than 0.002), % 58.0

Sample No. 34

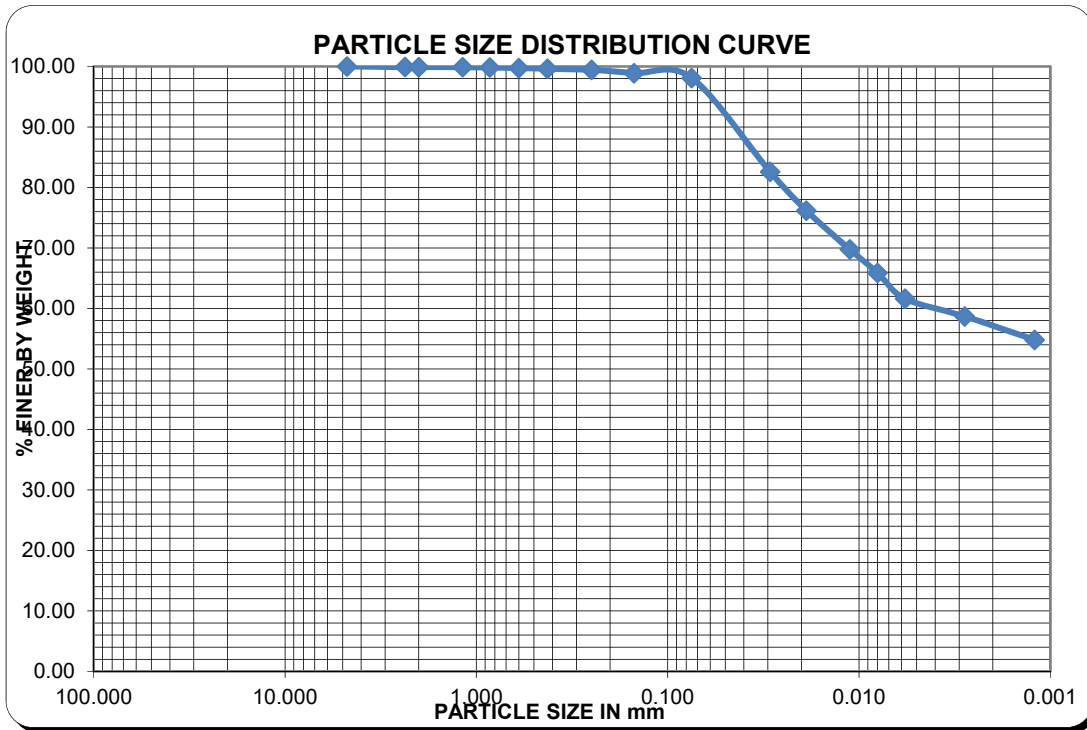

SIZE PROPORTIONS

Particle larger than 2.00 mm, %	<u>0.1</u>
Sand (2.00mm-0.075mm), %	<u>1.8</u>
Silt (0.075mm-0.002mm), %	<u>43.3</u>
Clay (less than 0.002), %	<u>54.8</u>

APPENDIX E – DCP TEST RESULTS

SOAKED CBR VALUE DETERMINATION FROM LABORATORY DCP TEST FOR ADDIS ABABA RED CLAY SOIL

Sample No.	1	Dry	Soaked
mold No	25	25	
Weight of wet soil + mold (gm)	12700	12995	
Weight of mold (gm)	8699	8699	
Weight of wet soil (gm)	4001	4296	
Volume of mold (cm ³)	2123	2123	
Wet density of soil (gm/cm ³)	1.88	2.02	
Dry density of soil (gm/cm ³)	1.52	1.52	
Moisture Content			
Can No	1	6	
Weight of wet soil + container (gm)	187.50	242.10	
Weight of dry soil + container (gm)	159.00	191.60	
Weight of container (gm)	38.80	37.90	
Weight of moisture (gm)	28.50	50.50	
Weight of dry soil (gm)	120.20	153.70	
Moisture Content, % (m)	23.71	32.86	

DCP depth vs Number of Blows for Un-soaked Condition

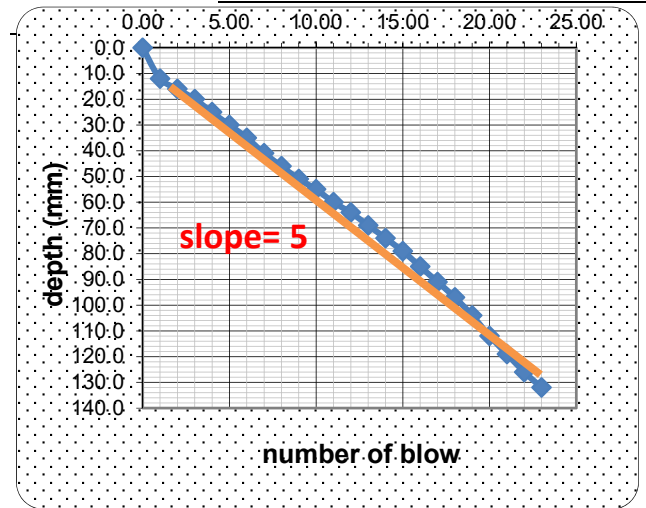

DCP depth vs Number of Blows for Soaked Condition

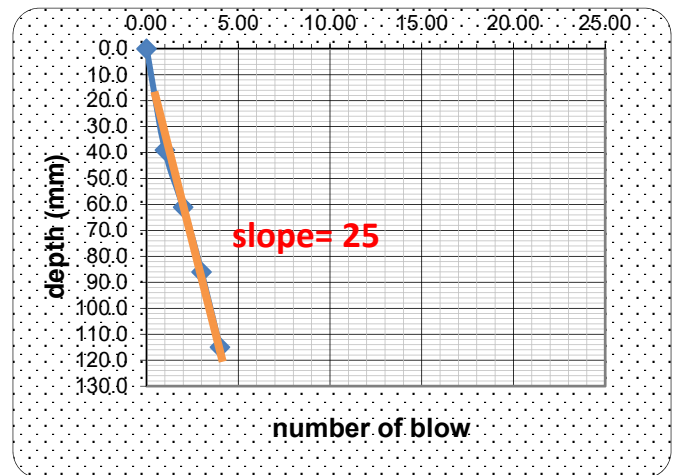

SOAKED CBR VALUE DETERMINATION FROM LABORATORY DCP TEST FOR ADDIS ABABA RED CLAY SOIL

Sample No.	2	Dry	Soaked
mold No	2	8	
Weight of wet soil + mold (gm)	12656	12800	
Weight of mold (gm)	8642	8644	
Weight of wet soil (gm)	4014	4156	
Volume of mold (cm ³)	2123	2123	
Wet density of soil (gm/cm ³)	1.89	1.96	
Dry density of soil (gm/cm ³)	1.52	1.52	
Moisture Content			
Can No	16	20	
Weight of wet soil + container (gm)	161.80	164.20	
Weight of dry soil + container (gm)	137.30	135.50	
Weight of container (gm)	35.90	34.80	
Weight of moisture (gm)	24.50	28.70	
Weight of dry soil (gm)	101.40	100.70	
Moisture Content, % (m)	24.16	28.50	

DCP depth vs Number of Blows for Un-soaked Condition

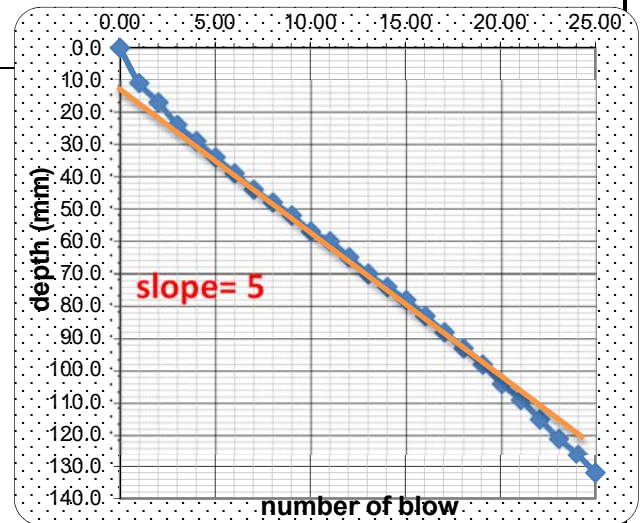

DCP depth vs Number of Blows for Soaked Condition

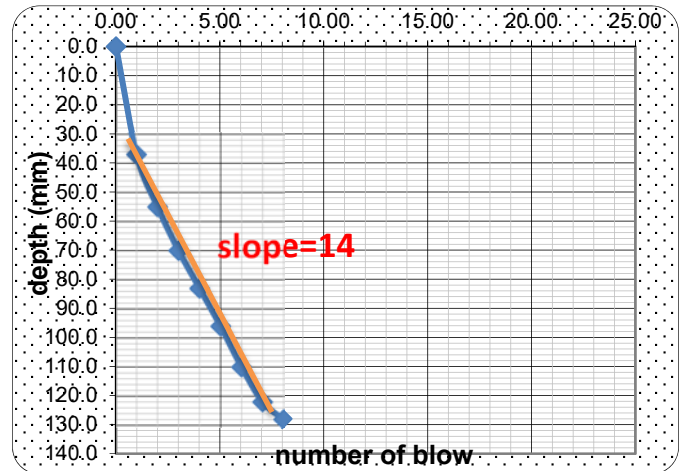

SOAKED CBR VALUE DETERMINATION FROM LABORATORY DCP TEST FOR ADDIS ABABA RED CLAY SOIL

Sample No.	3	Dry	Soaked
mold No	10	10	10
Weight of wet soil + mold (gm)	12885	13102	
Weight of mold (gm)	8815	8815	
Weight of wet soil (gm)	4070	4287	
Volume of mold (cm ³)	2123	2123	
Wet density of soil (gm/cm ³)	1.92	2.02	
Dry density of soil (gm/cm ³)	1.51	1.49	
Moisture Content			
Can No	3	2	
Weight of wet soil + container (gm)	170.00	191.00	
Weight of dry soil + container (gm)	141.70	151.40	
Weight of container (gm)	35.90	38.80	
Weight of moisture (gm)	28.30	39.60	
Weight of dry soil (gm)	105.80	112.60	
Moisture Content, % (m)	26.75	35.17	

DCP depth vs Number of Blows for Un-soaked Condition

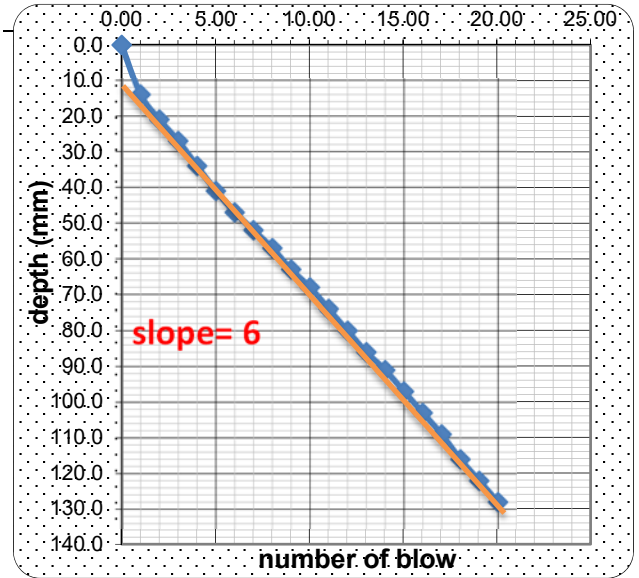

DCP depth vs Number of Blows for Soaked Condition

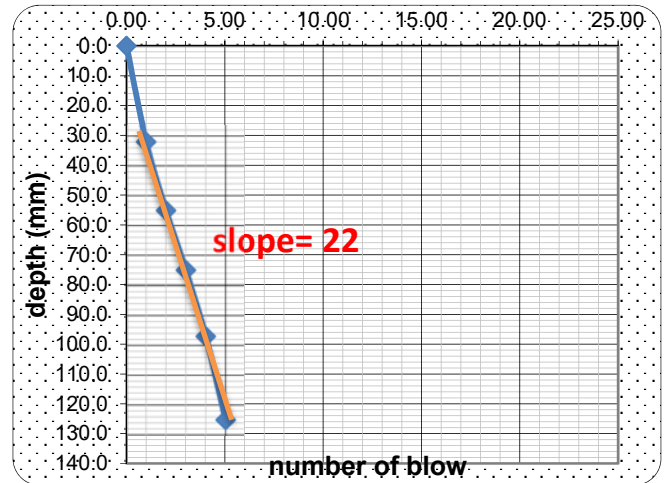

SOAKED CBR VALUE DETERMINATION FROM LABORATORY DCP TEST FOR ADDIS ABABA RED CLAY SOIL

Sample No.	4	Dry	Soaked
mold No	1	15	
Weight of wet soil + mold (gm)	12886	10836	
Weight of mold (gm)	8824	6540	
Weight of wet soil (gm)	4062	4296	
Volume of mold (cm ³)	2123	2123	
Wet density of soil (gm/cm ³)	1.91	2.02	
Dry density of soil (gm/cm ³)	1.51	1.51	
Moisture Content			
Can No	K	27	
Weight of wet soil + container (gm)	165.20	159.10	
Weight of dry soil + container (gm)	138.50	128.80	
Weight of container (gm)	37.90	38.70	
Weight of moisture (gm)	26.70	30.30	
Weight of dry soil (gm)	100.60	90.10	
Moisture Content, % (m)	26.54	33.63	

DCP depth vs Number of Blows for Un-soaked Condition

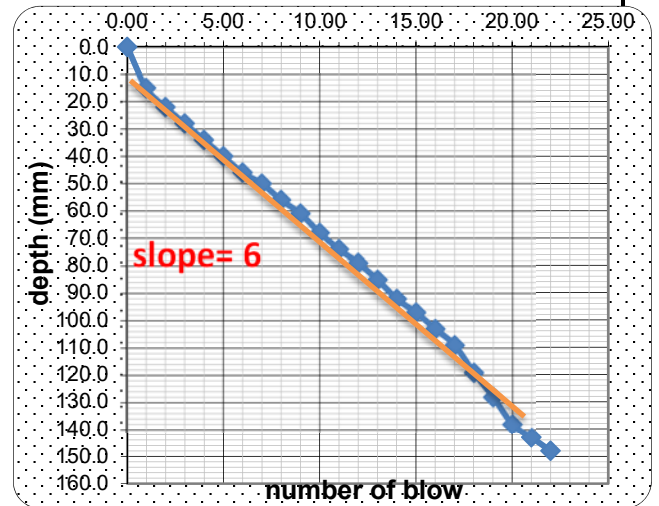

DCP depth vs Number of Blows for Soaked

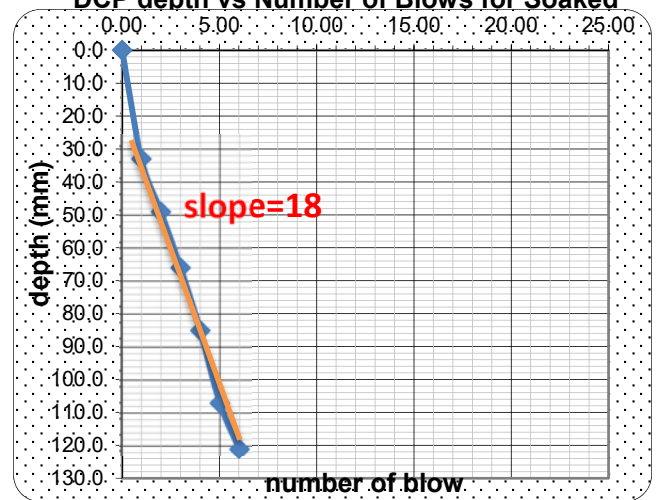

SOAKED CBR VALUE DETERMINATION FROM LABORATORY DCP TEST FOR ADDIS ABABA RED CLAY SOIL

Sample No.	5	Dry	Soaked
mold No	25	25	25
Weight of wet soil + mold (gm)	12758	13017	
Weight of mold (gm)	8699	8699	
Weight of wet soil (gm)	4059	4318	
Volume of mold (cm ³)	2123	2123	
Wet density of soil (gm/cm ³)	1.91	2.03	
Dry density of soil (gm/cm ³)	1.55	1.56	
Moisture Content			
Can No	22	8	
Weight of wet soil + container (gm)	188.00	180.50	
Weight of dry soil + container (gm)	159.40	147.60	
Weight of container (gm)	38.10	38.20	
Weight of moisture (gm)	28.60	32.90	
Weight of dry soil (gm)	121.30	109.40	
Moisture Content, % (m)	23.58	30.07	

DCP depth vs Number of Blows for Un-soaked Condition

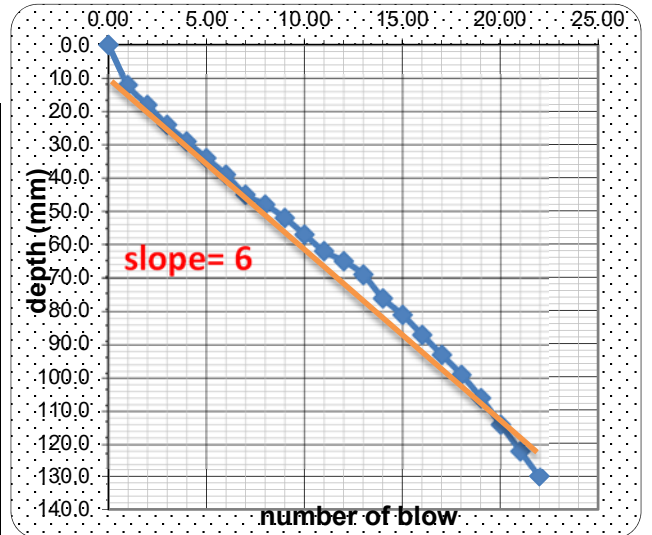

DCP depth vs Number of Blows for Soaked

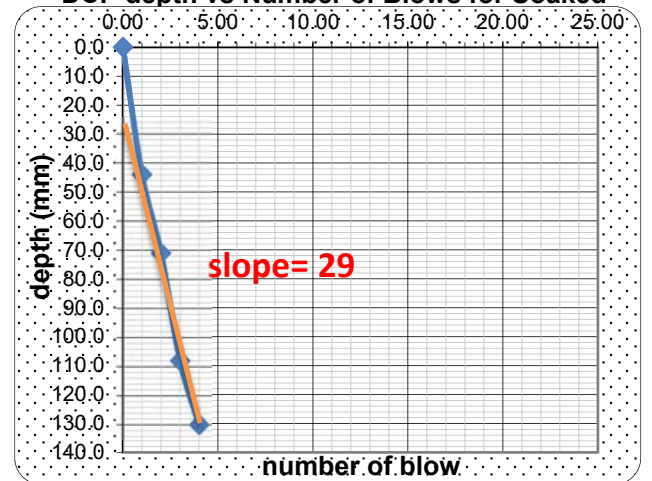

SOAKED CBR VALUE DETERMINATION FROM LABORATORY DCP TEST FOR ADDIS ABABA RED CLAY SOIL

Sample No.	6	Dry	Soaked
mold No			14
Weight of wet soil + mold (gm)	11056		11170
Weight of mold (gm)	6853		6717
Weight of wet soil (gm)	4203		4453
Volume of mold (cm ³)	2123		2123
Wet density of soil (gm/cm ³)	1.98		2.10
Dry density of soil (gm/cm ³)	1.58		1.56
Moisture Content			
Can No	17		AA
Weight of wet soil + container (gm)	239.30		204.10
Weight of dry soil + container (gm)	198.00		161.50
Weight of container (gm)	36.60		38.70
Weight of moisture (gm)	41.30		42.60
Weight of dry soil (gm)	161.40		122.80
Moisture Content, % (m)	25.59		34.69

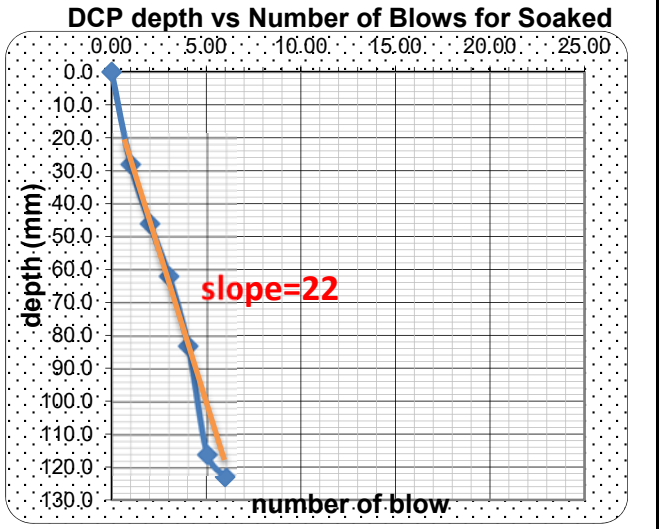
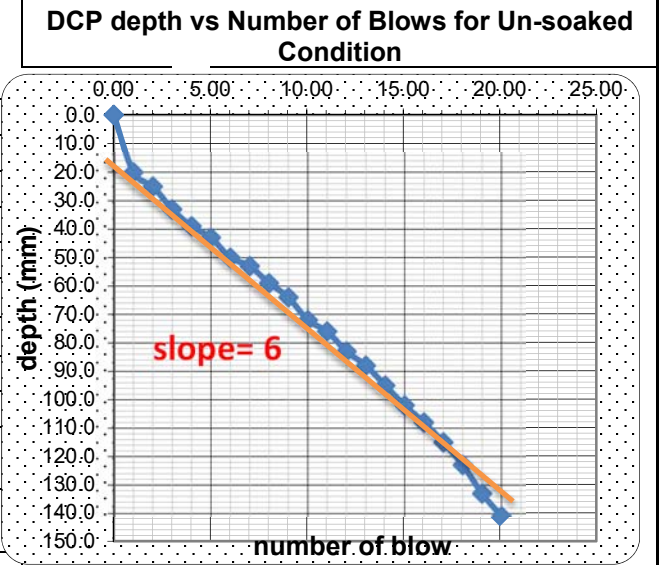

SOAKED CBR VALUE DETERMINATION FROM LABORATORY DCP TEST FOR ADDIS ABABA RED CLAY SOIL

Sample No.	7	Dry	Soaked
mold No	26	3	
Weight of wet soil + mold (gm)	13115	13115	
Weight of mold (gm)	8907	8553	
Weight of wet soil (gm)	4208	4562	
Volume of mold (cm ³)	2123	2123	
Wet density of soil (gm/cm ³)	1.98	2.15	
Dry density of soil (gm/cm ³)	1.61	1.60	
Moisture Content			
Can No	J	14	
Weight of wet soil + container (gm)	176.80	171.30	
Weight of dry soil + container (gm)	150.50	137.20	
Weight of container (gm)	36.00	38.00	
Weight of moisture (gm)	26.30	34.10	
Weight of dry soil (gm)	114.50	99.20	
Moisture Content, % (m)	22.97	34.38	

DCP depth vs Number of Blows for Un-soaked Condition

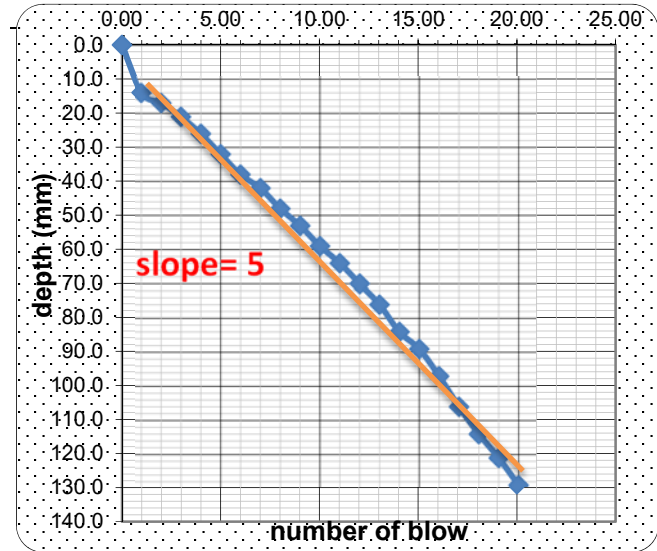

DCP depth vs Number of Blows for Soaked Condition

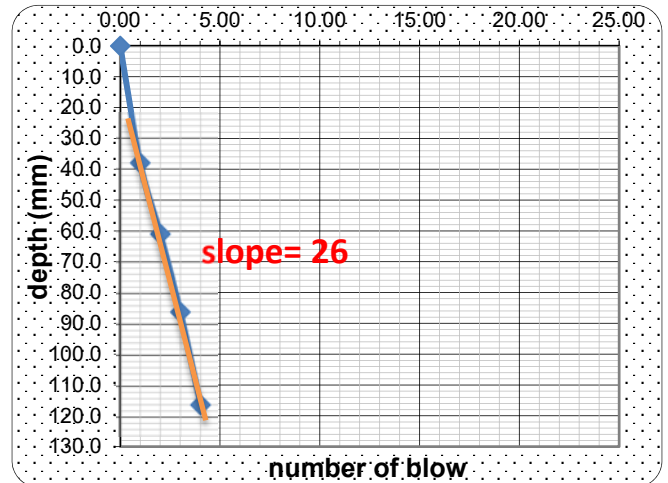

SOAKED CBR VALUE DETERMINATION FROM LABORATORY DCP TEST FOR ADDIS ABABA RED CLAY SOIL

Sample No.	8	Dry	Soaked
mold No			13
Weight of wet soil + mold (gm)	10040	10511	
Weight of mold (gm)	6232	6375	
Weight of wet soil (gm)	3808	4136	
Volume of mold (cm ³)	2123	2123	
Wet density of soil (gm/cm ³)	1.79	1.95	
Dry density of soil (gm/cm ³)	1.44	1.43	
Moisture Content			
Can No	13	28	
Weight of wet soil + container (gm)	140.70	231.80	
Weight of dry soil + container (gm)	120.40	179.30	
Weight of container (gm)	36.70	34.80	
Weight of moisture (gm)	20.30	52.50	
Weight of dry soil (gm)	83.70	144.50	
Moisture Content, % (m)	24.25	36.33	

DCP depth vs Number of Blows for Un-soaked Condition

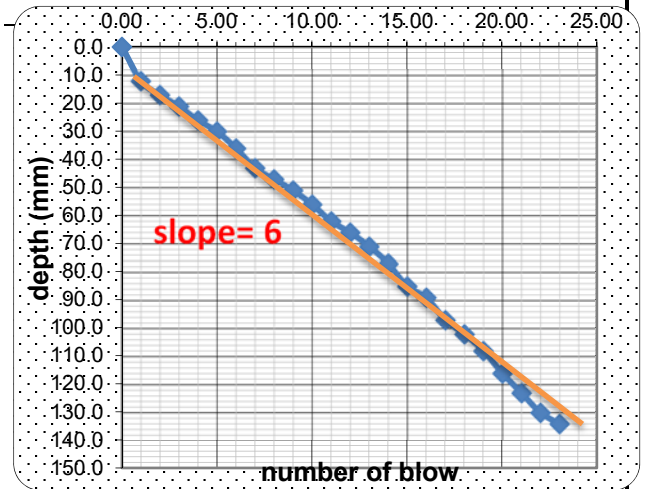

DCP depth vs Number of Blows for Soaked Condition

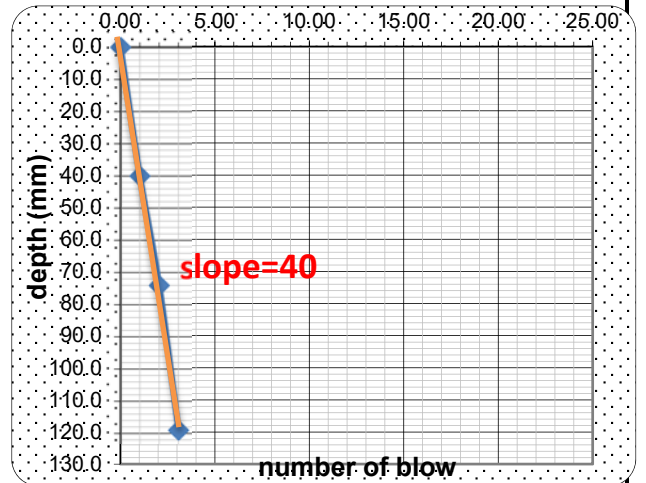

SOAKED CBR VALUE DETERMINATION FROM LABORATORY DCP TEST FOR ADDIS ABABA RED CLAY SOIL

Sample No.	9	Dry	Soaked
mold No	11	23	
Weight of wet soil + mold (gm)	10495	13279	
Weight of mold (gm)	6393	8814	
Weight of wet soil (gm)	4102	4465	
Volume of mold (cm ³)	2123	2123	
Wet density of soil (gm/cm ³)	1.93	2.10	
Dry density of soil (gm/cm ³)	1.55	1.53	
Moisture Content			
Can No	P	CC	
Weight of wet soil + container (gm)	182.20	190.90	
Weight of dry soil + container (gm)	153.60	149.90	
Weight of container (gm)	37.70	39.80	
Weight of moisture (gm)	28.60	41.00	
Weight of dry soil (gm)	115.90	110.10	
Moisture Content, % (m)	24.68	37.24	

DCP depth vs Number of Blows for Un-soaked Condition

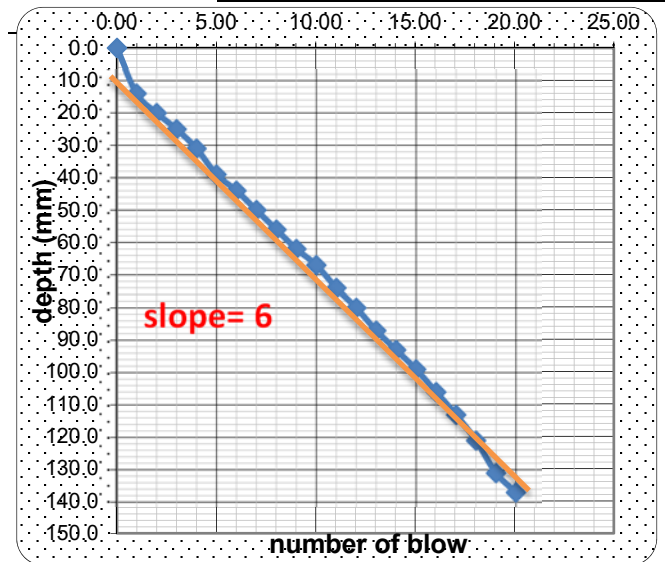

DCP depth vs Number of Blows for Soaked Condition

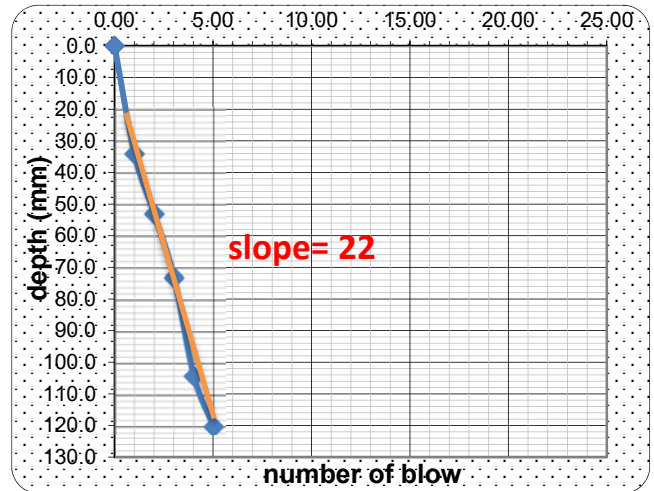

SOAKED CBR VALUE DETERMINATION FROM LABORATORY DCP TEST FOR ADDIS ABABA RED CLAY SOIL

Sample No.	10	Dry	Soaked
mold No	27	20	
Weight of wet soil + mold (gm)	12856	12939	
Weight of mold (gm)	8811	8619	
Weight of wet soil (gm)	4045	4320	
Volume of mold (cm ³)	2123	2123	
Wet density of soil (gm/cm ³)	1.91	2.03	
Dry density of soil (gm/cm ³)	1.54	1.54	
Moisture Content			
Can No	V	J	
Weight of wet soil + container (gm)	217.30	187.80	
Weight of dry soil + container (gm)	182.20	151.00	
Weight of container (gm)	36.70	36.00	
Weight of moisture (gm)	35.10	36.80	
Weight of dry soil (gm)	145.50	115.00	
Moisture Content, % (m)	24.12	32.00	

DCP depth vs Number of Blows for Un-soaked Condition

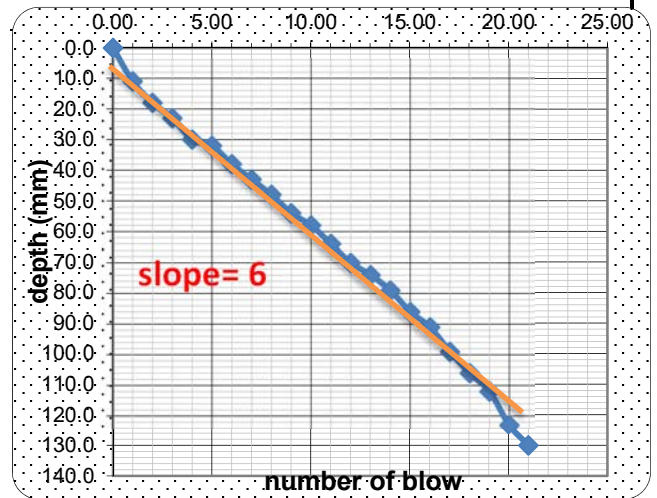

DCP depth vs Number of Blows for Soaked Condition

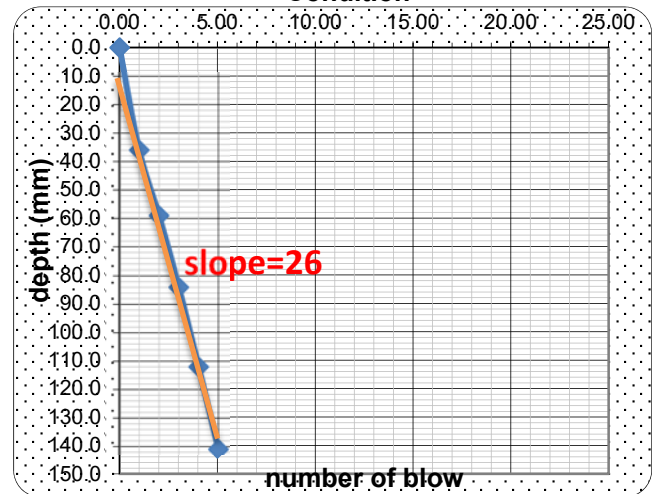

SOAKED CBR VALUE DETERMINATION FROM LABORATORY DCP TEST FOR ADDIS ABABA RED CLAY SOIL

Sample No.	11	Dry	Soaked
mold No	24	19	
Weight of wet soil + mold (gm)	12530	13105	
Weight of mold (gm)	8616	8846	
Weight of wet soil (gm)	3914	4259	
Volume of mold (cm ³)	2123	2123	
Wet density of soil (gm/cm ³)	1.84	2.01	
Dry density of soil (gm/cm ³)	1.53	1.52	
Moisture Content			
Can No	17	Y	
Weight of wet soil + container (gm)	162.90	211.50	
Weight of dry soil + container (gm)	141.70	169.30	
Weight of container (gm)	36.60	37.70	
Weight of moisture (gm)	21.20	42.20	
Weight of dry soil (gm)	105.10	131.60	
Moisture Content, % (m)	20.17	32.07	

DCP depth vs Number of Blows for Un-soaked Condition

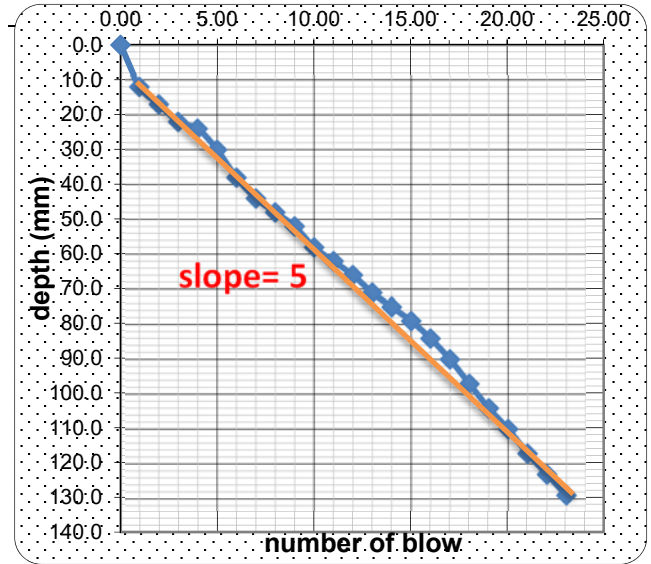

DCP depth vs Number of Blows for Soaked

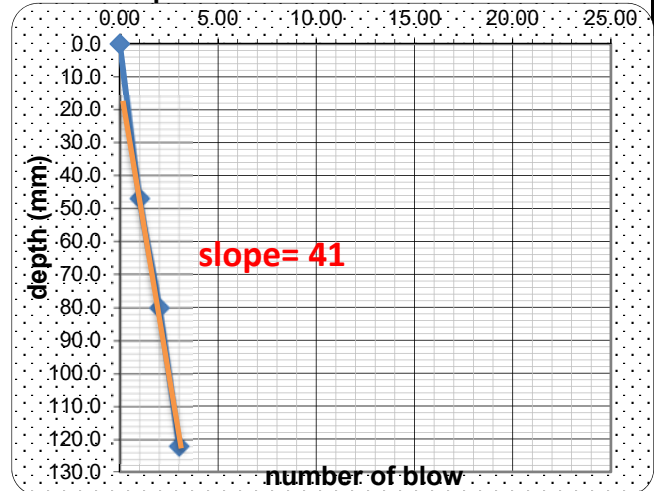

SOAKED CBR VALUE DETERMINATION FROM LABORATORY DCP TEST FOR ADDIS ABABA RED CLAY SOIL

Sample No.	12	Dry	Soaked
mold No	8	8	8
Weight of wet soil + mold (gm)	12842	13016	
Weight of mold (gm)	8644	8644	
Weight of wet soil (gm)	4198	4372	
Volume of mold (cm ³)	2123	2123	
Wet density of soil (gm/cm ³)	1.98	2.06	
Dry density of soil (gm/cm ³)	1.63	1.60	
Moisture Content			
Can No	9	15	
Weight of wet soil + container (gm)	175.40	184.80	
Weight of dry soil + container (gm)	151.40	151.60	
Weight of container (gm)	38.00	37.00	
Weight of moisture (gm)	24.00	33.20	
Weight of dry soil (gm)	113.40	114.60	
Moisture Content, % (m)	21.16	28.97	

DCP depth vs Number of Blows for Un-soaked Condition

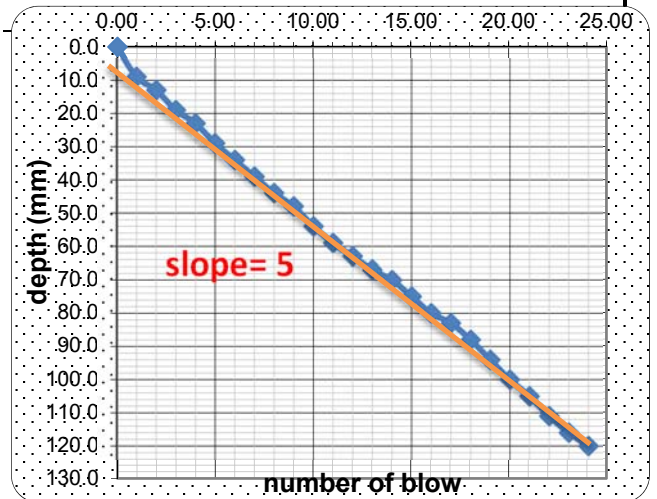

DCP depth vs Number of Blows for Soaked

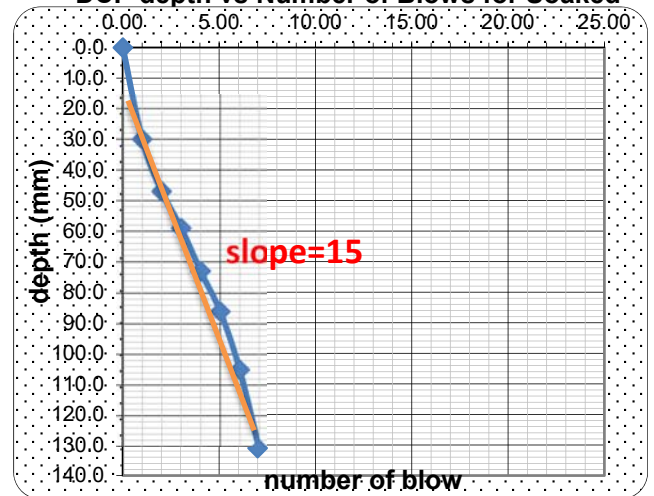

SOAKED CBR VALUE DETERMINATION FROM LABORATORY DCP TEST FOR ADDIS ABABA RED CLAY SOIL

Sample No.	13	Dry	Soaked
mold No	26	26	
Weight of wet soil + mold (gm)	13070	13303	
Weight of mold (gm)	8907	8907	
Weight of wet soil (gm)	4163	4396	
Volume of mold (cm ³)	2123	2123	
Wet density of soil (gm/cm ³)	1.96	2.07	
Dry density of soil (gm/cm ³)	1.57	1.58	
Moisture Content			
Can No	AA	S	
Weight of wet soil + container (gm)	162.80	223.70	
Weight of dry soil + container (gm)	138.00	179.60	
Weight of container (gm)	38.70	36.60	
Weight of moisture (gm)	24.80	44.10	
Weight of dry soil (gm)	99.30	143.00	
Moisture Content, % (m)	24.97	30.84	

DCP depth vs Number of Blows for Un-soaked Condition

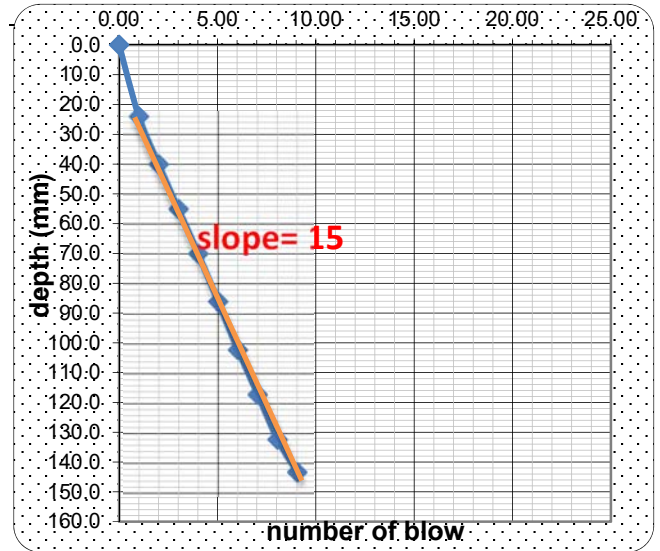

DCP depth vs Number of Blows for Soaked Condition

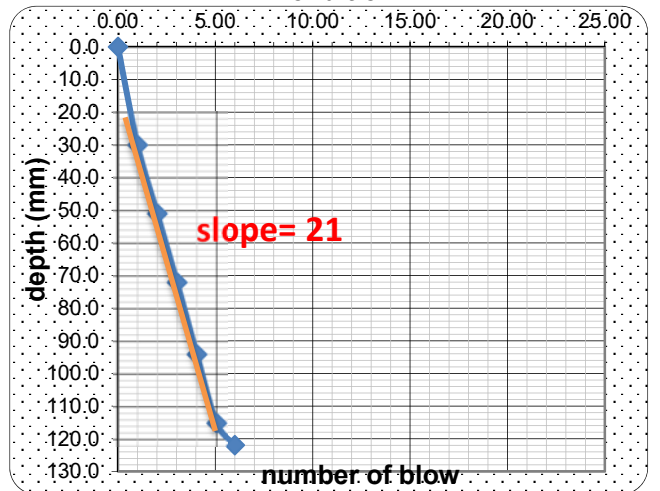

SOAKED CBR VALUE DETERMINATION FROM LABORATORY DCP TEST FOR ADDIS ABABA RED CLAY SOIL

Sample No.	14	Dry	Soaked
mold No	1	1	1
Weight of wet soil + mold (gm)	13012	13116	
Weight of mold (gm)	8824	8824	
Weight of wet soil (gm)	4188	4292	
Volume of mold (cm ³)	2123	2123	
Wet density of soil (gm/cm ³)	1.97	2.02	
Dry density of soil (gm/cm ³)	1.58	1.60	
Moisture Content			
Can No	D	10	
Weight of wet soil + container (gm)	189.20	189.70	
Weight of dry soil + container (gm)	159.40	157.10	
Weight of container (gm)	37.60	35.10	
Weight of moisture (gm)	29.80	32.60	
Weight of dry soil (gm)	121.80	122.00	
Moisture Content, % (m)	24.47	26.72	

DCP depth vs Number of Blows for Un-soaked Condition

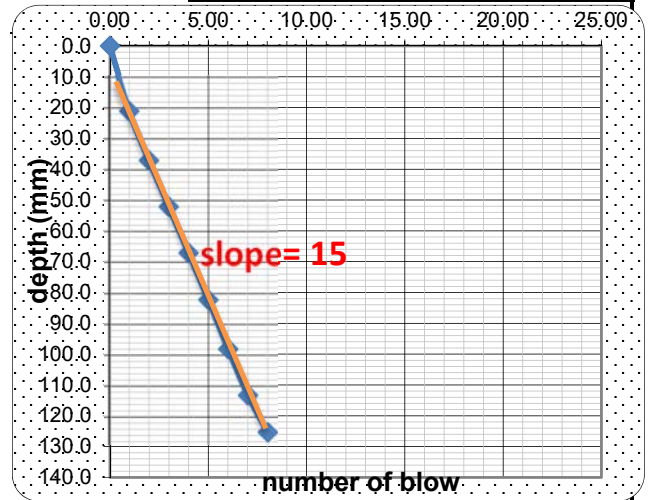

DCP depth vs Number of Blows for Soaked Condition

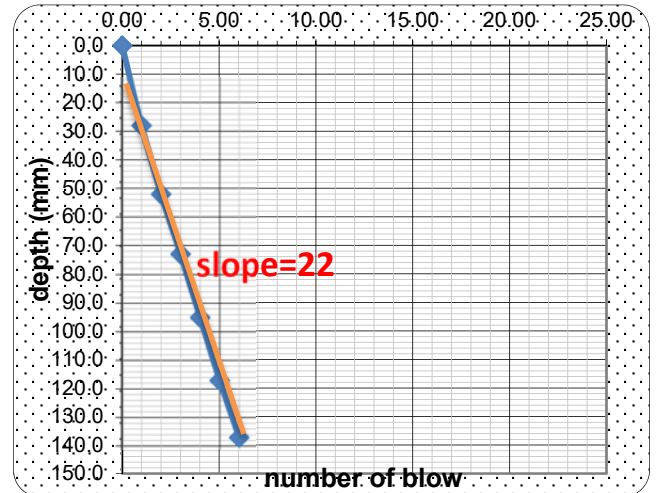

SOAKED CBR VALUE DETERMINATION FROM LABORATORY DCP TEST FOR ADDIS ABABA RED CLAY SOIL

Sample No.	15	Dry	Soaked
mold No	14	15	
Weight of wet soil + mold (gm)	10881	10792	
Weight of mold (gm)	6717	6540	
Weight of wet soil (gm)	4164	4252	
Volume of mold (cm ³)	2123	2123	
Wet density of soil (gm/cm ³)	1.96	2.00	
Dry density of soil (gm/cm ³)	1.58	1.59	
Moisture Content			
Can No	15	18	
Weight of wet soil + container (gm)	181.40	168.00	
Weight of dry soil + container (gm)	153.50	140.30	
Weight of container (gm)	37.00	35.00	
Weight of moisture (gm)	27.90	27.70	
Weight of dry soil (gm)	116.50	105.30	
Moisture Content, % (m)	23.95	26.31	

DCP depth vs Number of Blows for Un-soaked Condition

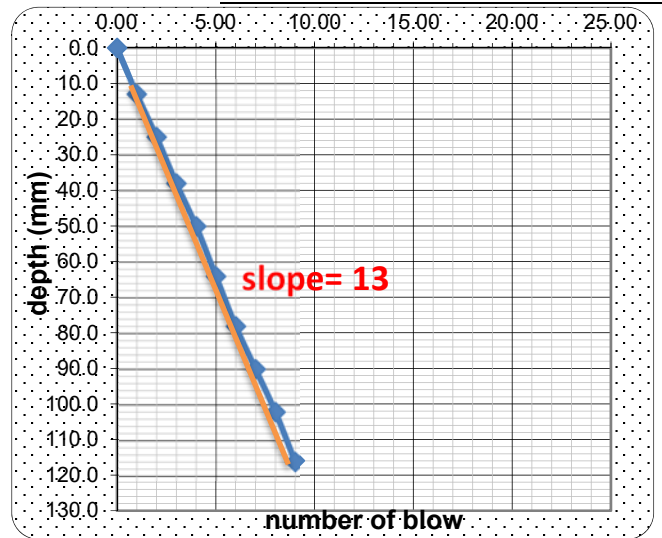

DCP depth vs Number of Blows for Soaked Condition

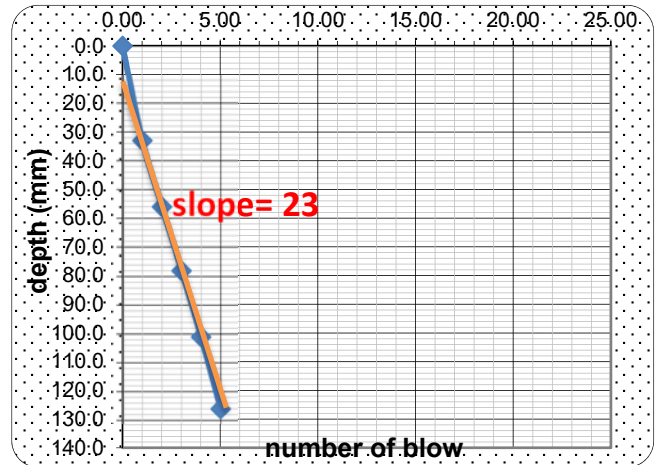

SOAKED CBR VALUE DETERMINATION FROM LABORATORY DCP TEST FOR ADDIS ABABA RED CLAY SOIL

Sample No.	17	Dry	Soaked
mold No	6	14	
Weight of wet soil + mold (gm)	13054	11029	
Weight of mold (gm)	8917	6717	
Weight of wet soil (gm)	4137	4312	
Volume of mold (cm ³)	2123	2123	
Wet density of soil (gm/cm ³)	1.95	2.03	
Dry density of soil (gm/cm ³)	1.61	1.59	
Moisture Content			
Can No	N	29	
Weight of wet soil + container (gm)	192.70	177.60	
Weight of dry soil + container (gm)	165.30	147.00	
Weight of container (gm)	36.20	37.30	
Weight of moisture (gm)	27.40	30.60	
Weight of dry soil (gm)	129.10	109.70	
Moisture Content, % (m)	21.22	27.89	

DCP depth vs Number of Blows for Un-soaked Condition

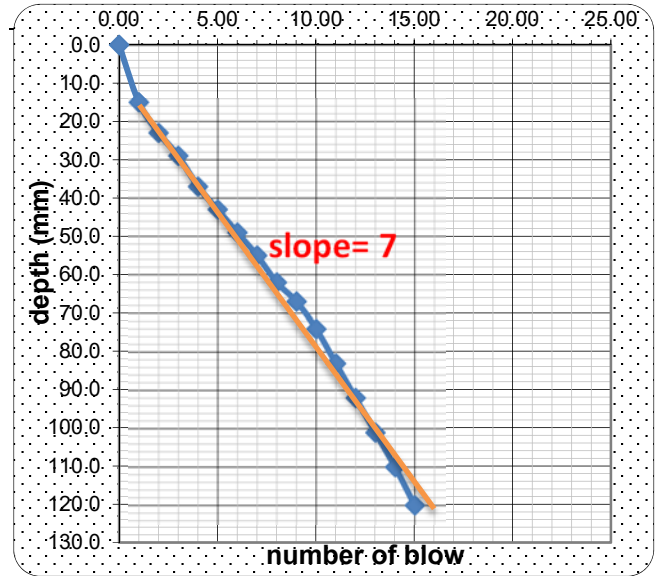

DCP depth vs Number of Blows for Soaked Condition

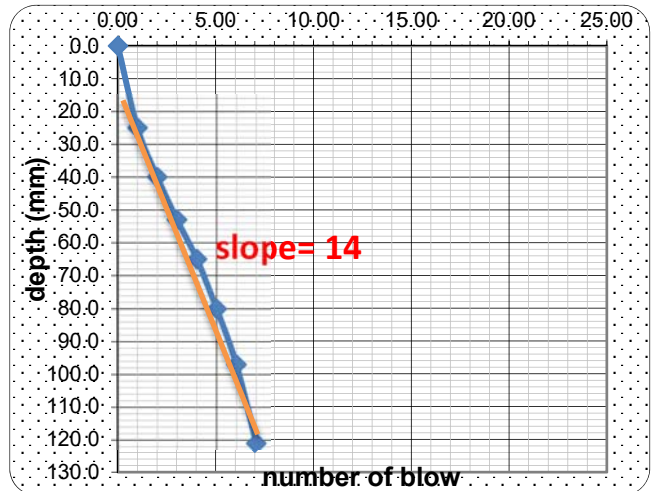

SOAKED CBR VALUE DETERMINATION FROM LABORATORY DCP TEST FOR ADDIS ABABA RED CLAY SOIL

Sample No.	18	Dry	Soaked
mold No	27	21	
Weight of wet soil + mold (gm)	12868	10628	
Weight of mold (gm)	8811	6337	
Weight of wet soil (gm)	4057	4291	
Volume of mold (cm ³)	2123	2123	
Wet density of soil (gm/cm ³)	1.91	2.02	
Dry density of soil (gm/cm ³)	1.57	1.57	
Moisture Content			
Can No	14	S	
Weight of wet soil + container (gm)	204.20	232.00	
Weight of dry soil + container (gm)	174.60	188.60	
Weight of container (gm)	38.00	37.00	
Weight of moisture (gm)	29.60	43.40	
Weight of dry soil (gm)	136.60	151.60	
Moisture Content, % (m)	21.67	28.63	

DCP depth vs Number of Blows for Un-soaked Condition

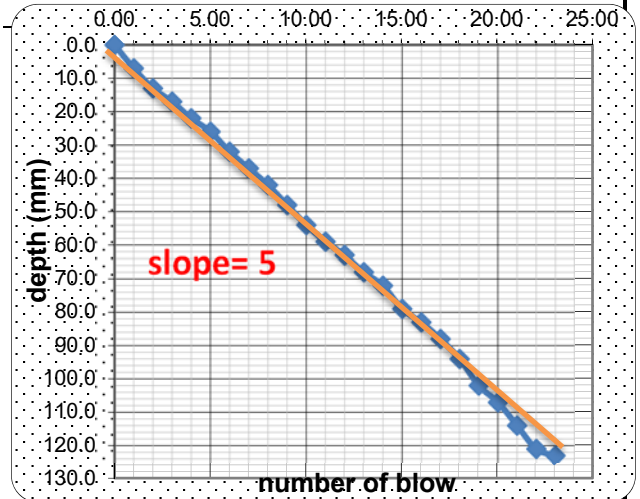

DCP depth vs Number of Blows for Soaked Condition

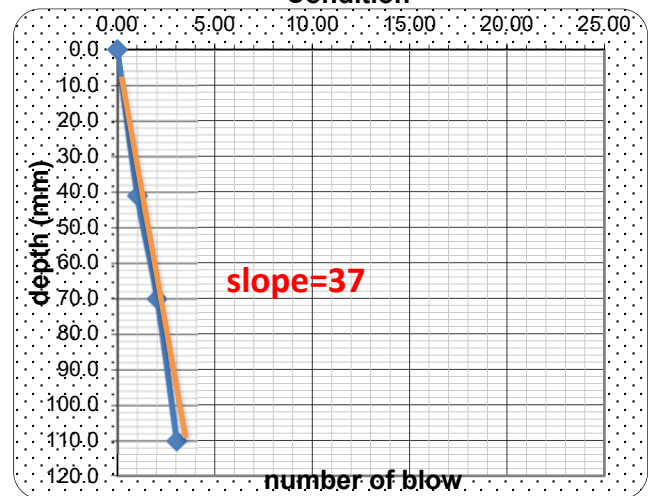

SOAKED CBR VALUE DETERMINATION FROM LABORATORY DCP TEST FOR ADDIS ABABA RED CLAY SOIL

Sample No.	19	Dry	Soaked
mold No	19	19	19
Weight of wet soil + mold (gm)	13141	13270	
Weight of mold (gm)	8846	8846	
Weight of wet soil (gm)	4295	4424	
Volume of mold (cm ³)	2123	2123	
Wet density of soil (gm/cm ³)	2.02	2.08	
Dry density of soil (gm/cm ³)	1.63	1.64	
Moisture Content			
Can No	x	DD	
Weight of wet soil + container (gm)	229.60	182.70	
Weight of dry soil + container (gm)	192.70	151.90	
Weight of container (gm)	37.30	38.60	
Weight of moisture (gm)	36.90	30.80	
Weight of dry soil (gm)	155.40	113.30	
Moisture Content, % (m)	23.75	27.18	

DCP depth vs Number of Blows for Un-soaked Condition

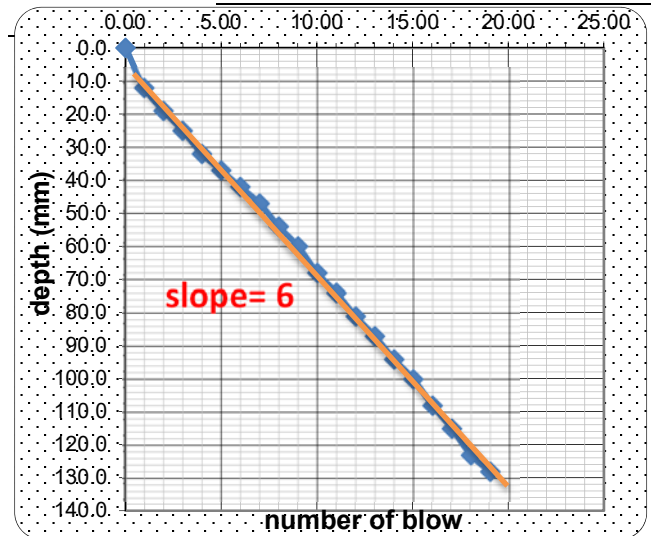

DCP depth vs Number of Blows for Soaked Condition

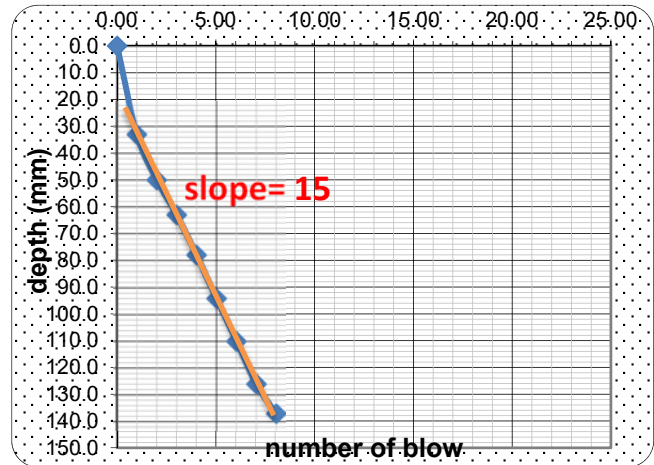

SOAKED CBR VALUE DETERMINATION FROM LABORATORY DCP TEST FOR ADDIS ABABA RED CLAY SOIL

Sample No.	21	Dry	Soaked
mold No	22	3	
Weight of wet soil + mold (gm)	10534	12820	
Weight of mold (gm)	6279	8553	
Weight of wet soil (gm)	4255	4267	
Volume of mold (cm ³)	2123	2123	
Wet density of soil (gm/cm ³)	2.00	2.01	
Dry density of soil (gm/cm ³)	1.64	1.63	
Moisture Content			
Can No	8	G	
Weight of wet soil + container (gm)	159.70	188.90	
Weight of dry soil + container (gm)	137.50	159.90	
Weight of container (gm)	38.20	37.00	
Weight of moisture (gm)	22.20	29.00	
Weight of dry soil (gm)	99.30	122.90	
Moisture Content, % (m)	22.36	23.60	

DCP depth vs Number of Blows for Un-soaked Condition

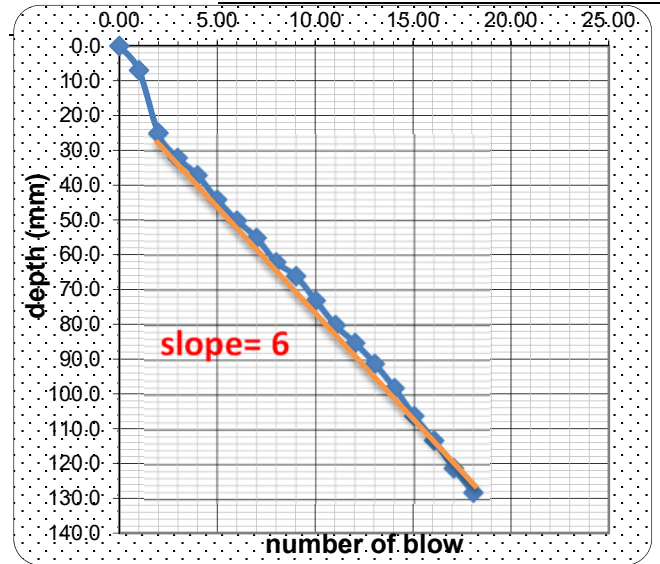

DCP depth vs Number of Blows for Soaked Condition

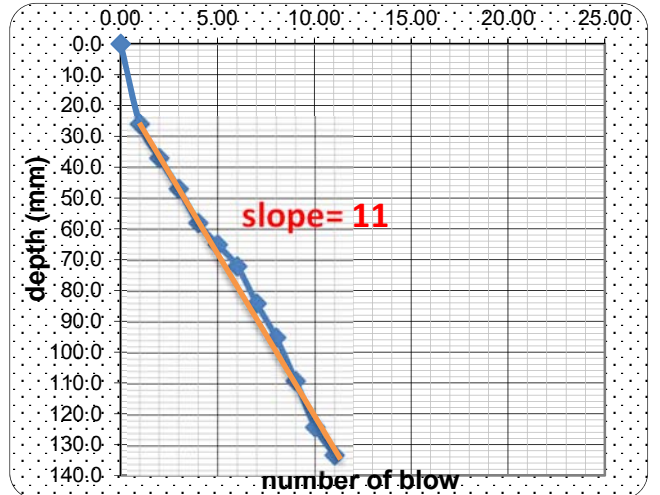

SOAKED CBR VALUE DETERMINATION FROM LABORATORY DCP TEST FOR ADDIS ABABA RED CLAY SOIL

Sample No.	22	Dry	Soaked
mold No	7	7	7
Weight of wet soil + mold (gm)	12930	12999	12999
Weight of mold (gm)	8644	8644	8644
Weight of wet soil (gm)	4286	4355	4355
Volume of mold (cm ³)	2123	2123	2123
Wet density of soil (gm/cm ³)	2.02	2.05	2.05
Dry density of soil (gm/cm ³)	1.63	1.60	1.60
Moisture Content			
Can No	E	R	R
Weight of wet soil + container (gm)	176.20	172.90	172.90
Weight of dry soil + container (gm)	149.20	142.80	142.80
Weight of container (gm)	36.90	35.70	35.70
Weight of moisture (gm)	27.00	30.10	30.10
Weight of dry soil (gm)	112.30	107.10	107.10
Moisture Content, % (m)	24.04	28.10	28.10

DCP depth vs Number of Blows for Un-soaked Condition

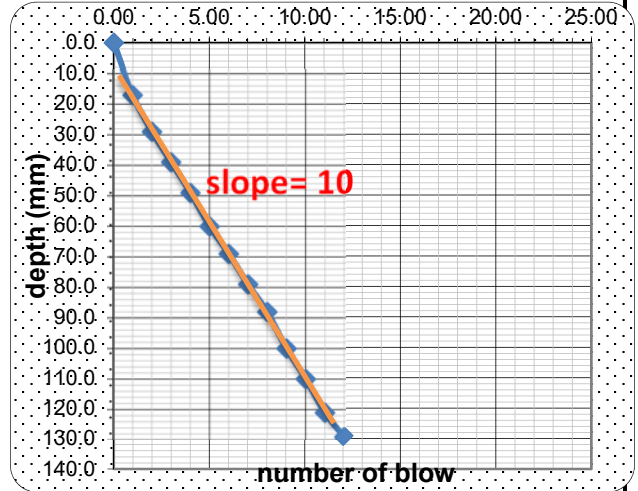

DCP depth vs Number of Blows for Soaked Condition

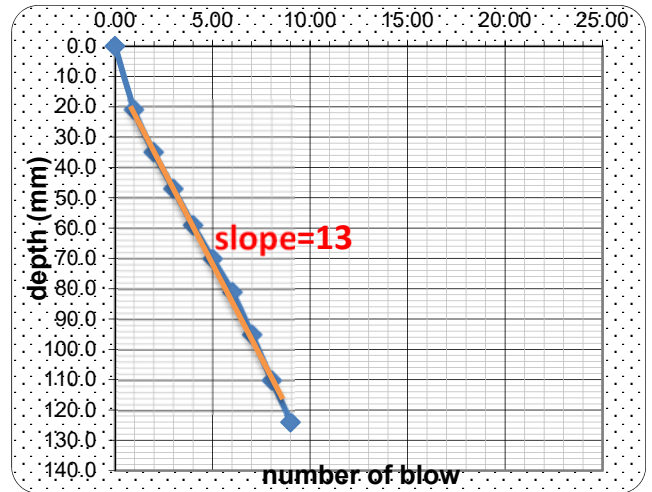

SOAKED CBR VALUE DETERMINATION FROM LABORATORY DCP TEST FOR ADDIS ABABA RED CLAY SOIL

Sample No.	29	Dry	Soaked
mold No	21	6	
Weight of wet soil + mold (gm)	10743	13027	
Weight of mold (gm)	6337	0	
Weight of wet soil (gm)	4406	13027	
Volume of mold (cm ³)	2123	2124	
Wet density of soil (gm/cm ³)	2.08	6.13	
Dry density of soil (gm/cm ³)	1.63	4.82	
Moisture Content			
Can No	20	u	
Weight of wet soil + container (gm)	268.50	158.50	
Weight of dry soil + container (gm)	217.80	132.20	
Weight of container (gm)	34.80	35.90	
Weight of moisture (gm)	50.70	26.30	
Weight of dry soil (gm)	183.00	96.30	
Moisture Content, % (m)	27.70	27.31	

DCP depth vs Number of Blows for Un-soaked Condition

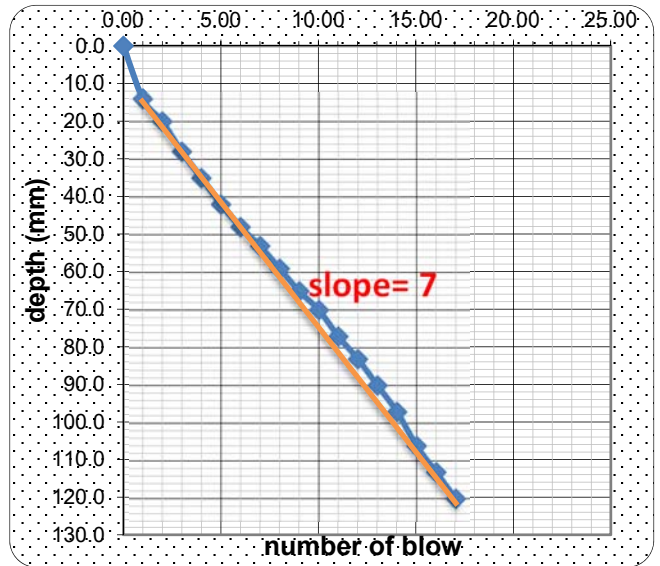

DCP depth vs Number of Blows for Soaked Condition

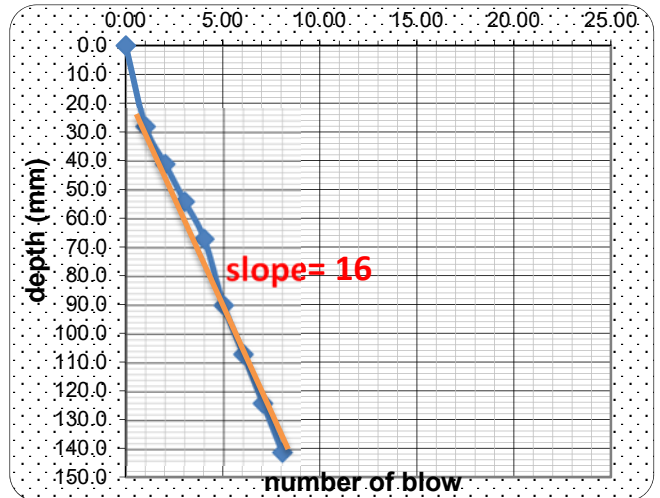

SOAKED CBR VALUE DETERMINATION FROM LABORATORY DCP TEST FOR ADDIS ABABA RED CLAY SOIL

Sample No.	30	Dry	Soaked
mold No	15	13	
Weight of wet soil + mold (gm)	10714	10633	
Weight of mold (gm)	6540	6375	
Weight of wet soil (gm)	4174	4258	
Volume of mold (cm ³)	2123	2123	
Wet density of soil (gm/cm ³)	1.97	2.01	
Dry density of soil (gm/cm ³)	1.53	1.53	
Moisture Content			
Can No	Y	12	
Weight of wet soil + container (gm)	150.60	233.40	
Weight of dry soil + container (gm)	125.60	187.50	
Weight of container (gm)	37.70	37.90	
Weight of moisture (gm)	25.00	45.90	
Weight of dry soil (gm)	87.90	149.60	
Moisture Content, % (m)	28.44	30.68	

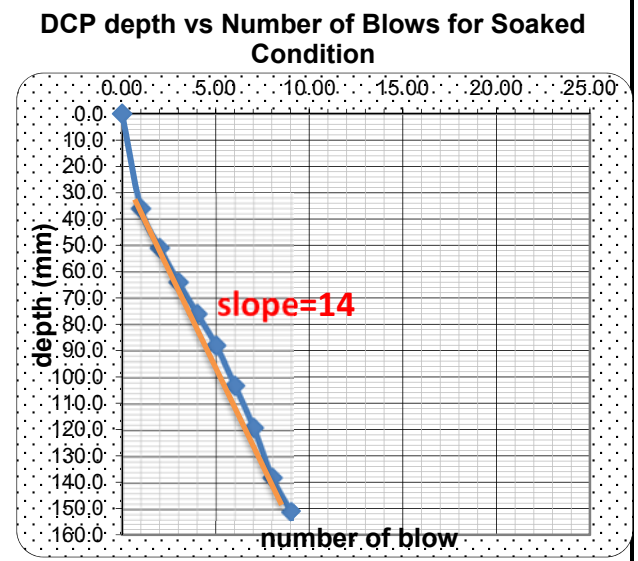
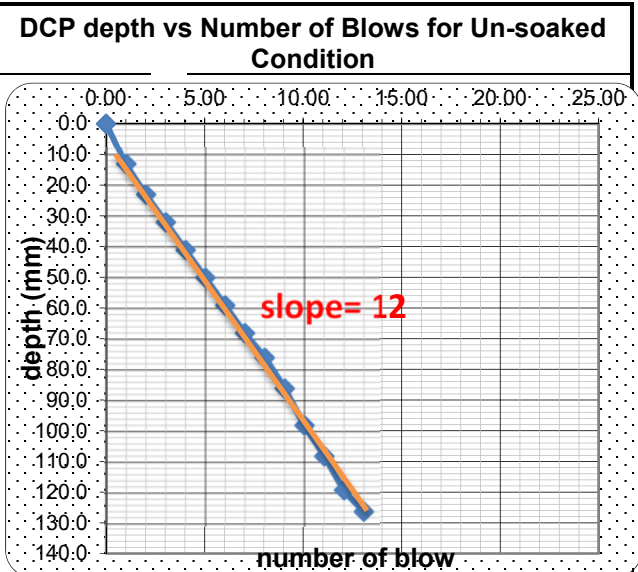

SOAKED CBR VALUE DETERMINATION FROM LABORATORY DCP TEST FOR ADDIS ABABA RED CLAY SOIL

Sample No.	33	Dry	Soaked
mold No	9	5	
Weight of wet soil + mold (gm)	10674	13204	
Weight of mold (gm)	6342	8793	
Weight of wet soil (gm)	4332	4411	
Volume of mold (cm ³)	2123	2123	
Wet density of soil (gm/cm ³)	2.04	2.08	
Dry density of soil (gm/cm ³)	1.57	1.56	
Moisture Content			
Can No	I	22	
Weight of wet soil + container (gm)	233.10	191.10	
Weight of dry soil + container (gm)	188.50	152.70	
Weight of container (gm)	38.50	38.10	
Weight of moisture (gm)	44.60	38.40	
Weight of dry soil (gm)	150.00	114.60	
Moisture Content, % (m)	29.73	33.51	

DCP depth vs Number of Blows for Un-soaked Condition

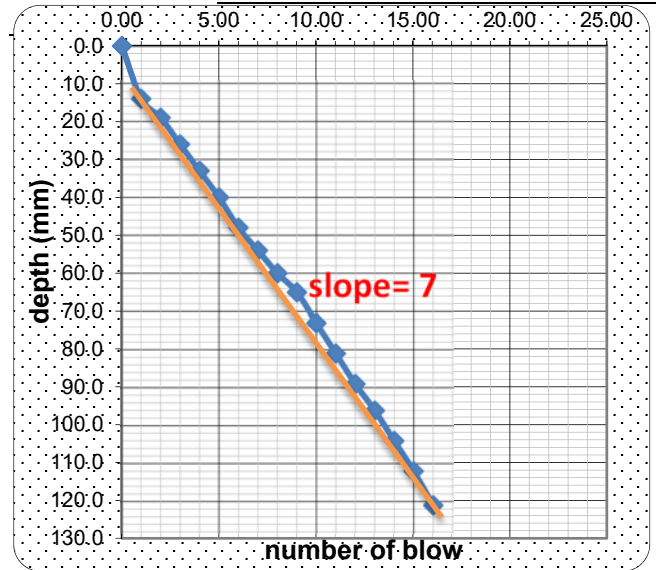

DCP depth vs Number of Blows for Soaked Condition

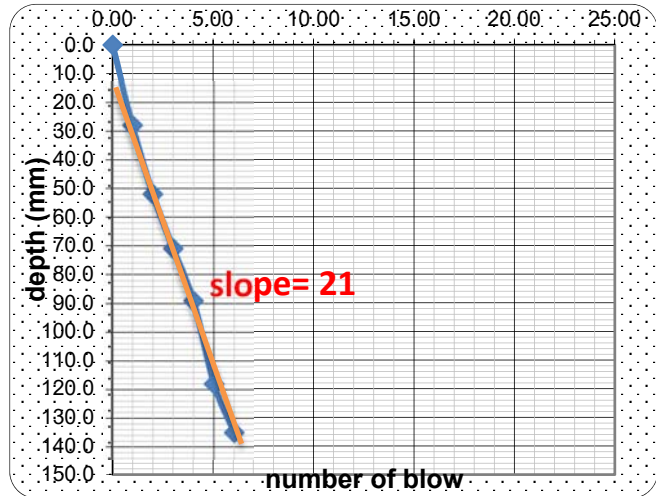

SOAKED CBR VALUE DETERMINATION FROM LABORATORY DCP TEST FOR ADDIS ABABA RED CLAY SOIL

Sample No.	34	Dry	Soaked
mold No	10	10	10
Weight of wet soil + mold (gm)	13109	13381	
Weight of mold (gm)	8815	8815	
Weight of wet soil (gm)	4294	4566	
Volume of mold (cm ³)	2123	2123	
Wet density of soil (gm/cm ³)	2.02	2.15	
Dry density of soil (gm/cm ³)	1.59	1.59	
Moisture Content			
Can No	16	M	
Weight of wet soil + container (gm)	243.90	170.70	
Weight of dry soil + container (gm)	199.20	136.20	
Weight of container (gm)	35.90	37.30	
Weight of moisture (gm)	44.70	34.50	
Weight of dry soil (gm)	163.30	98.90	
Moisture Content, % (m)	27.37	34.88	

DCP depth vs Number of Blows for Un-soaked Condition

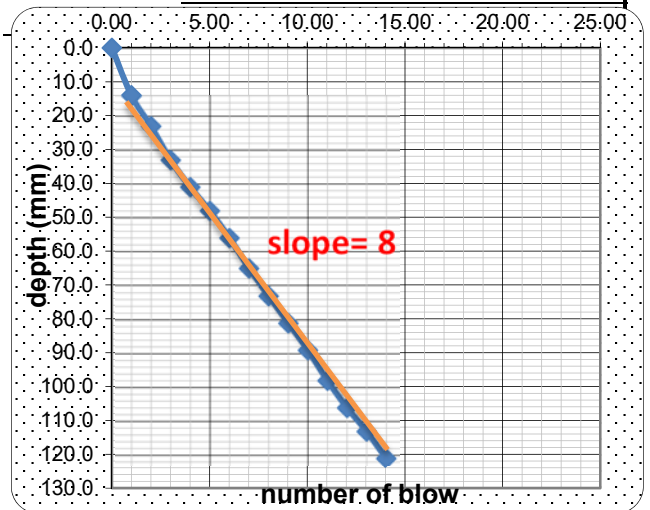

DCP depth vs Number of Blows for Soaked Condition

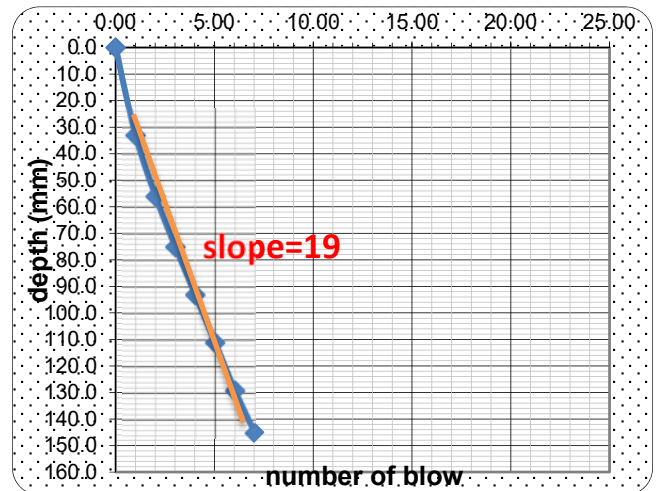

APPENDIX F – CBR TEST RESULTS

SOAKED CBR VALUE DETERMINATION FROM LABORATORY DCP TEST FOR ADDIS ABABA RED CLAY SOIL

Sample No.	:1	Dry	Soaked
Mold No		16	16
Weight of wet soil + Mold (gm)		12609	12889
Weight of Mold (gm)		8645	8645
Weight of wet soil (gm)		3964	4244
Volume of Mold (cm ³)		2123	2123
Wet density of soil (gm/cm ³)		1.87	2.00
Dry density of soil (gm/cm ³)		1.51	1.51
Moisture Content			
Can No		I	L
Weight of wet soil + container (gm)		187.50	192.60
Weight of dry soil + container (gm)		159.00	154.60
Weight of container (gm)		38.80	37.30
Weight of moisture (gm)		28.50	38.00
Weight of dry soil (gm)		120.20	117.30
Moisture Content, % (m)		23.71	32.40

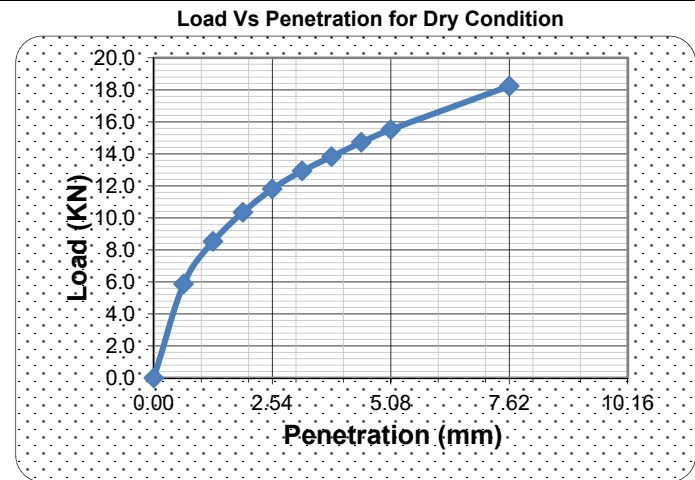

PENETRATION DATA					
				Ring Factor (KN/DIV)	0.033153
Dry			Soaked		
Pen.(mm)	Dial Reading	Load (KN)	Pen.(mm)	Dial Reading	Load (KN)
0.0		0.0	0.0		0.0
0.64	177.0	5.9	0.64	6.0	0.2
1.27	257.0	8.5	1.27	12.0	0.4
1.91	312.0	10.3	1.91	24.0	0.8
2.54	356.0	11.8	2.54	35.0	1.2
3.18	390.0	12.9	3.18	40.0	1.3
3.81	417.0	13.8	3.81	47.0	1.6
4.45	444.0	14.7	4.45	55.0	1.8
5.08	468.0	15.5	5.08	61.0	2.0
7.62	550.0	18.2	7.62	74.0	2.5
10.16		0.0	10.16		0.0
Dry CBR %			Soaked CBR %		
2.54mm	5.08mm	Corrected	2.54mm	5.08mm	Corrected
89.1	77.7	89.1	8.8	10.1	10.1

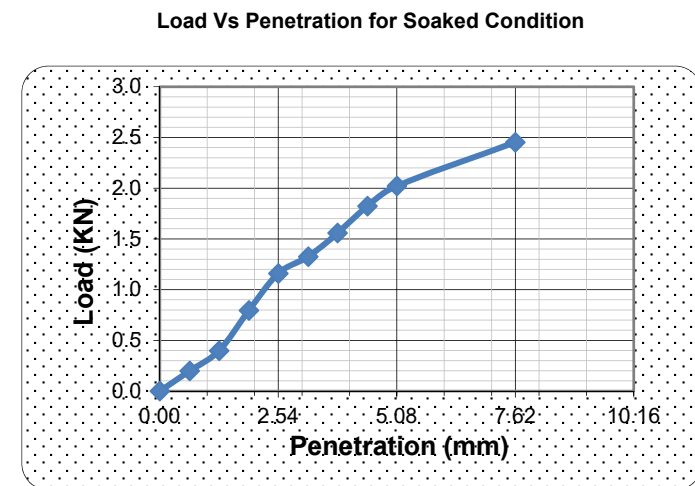

Swell Data		
Initial R.	Final R.	Swell (%)
7.61	13.51	5.07

SOAKED CBR VALUE DETERMINATION FROM LABORATORY DCP TEST FOR ADDIS ABABA RED CLAY SOIL

Sample No.	:2	Dry	Soaked
Mold No		24	21
Weight of wet soil + Mold (gm)		12627	10476
Weight of Mold (gm)		8616	6337
Weight of wet soil (gm)		4011	4139
Volume of Mold (cm ³)		2123	2123
Wet density of soil (gm/cm ³)		1.89	1.95
Dry density of soil (gm/cm ³)		1.52	1.51
Moisture Content			
Can No		1	16
Weight of wet soil + container (gm)		183.00	189.00
Weight of dry soil + container (gm)		154.80	154.60
Weight of container (gm)		38.50	35.90
Weight of moisture (gm)		28.20	34.40
Weight of dry soil (gm)		116.30	118.70
Moisture Content, % (m)		24.25	28.98

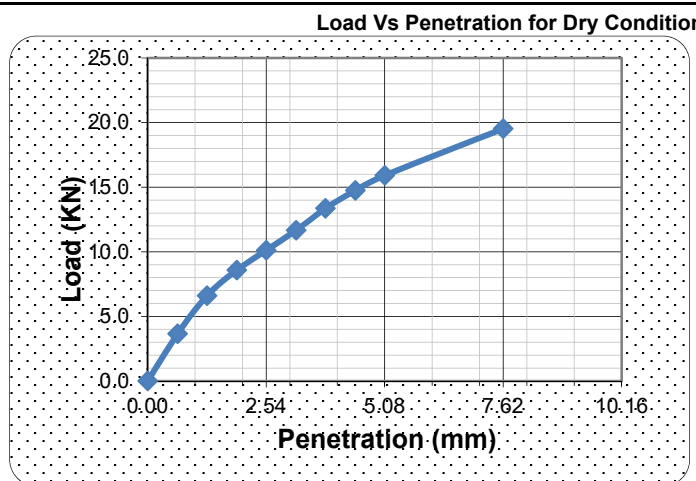

PENETRATION DATA

		Ring Factor (KN/DIV)	0.033153
--	--	----------------------	----------

Pen.(mm)	Dry		Soaked		
	Dial	Load	Pen.(mm)	Dial	Load
	Reading	(KN)		Reading	(KN)
0.0		0.0	0.0		0.0
0.64	110.0	3.6	0.64	6.0	0.2
1.27	199.0	6.6	1.27	14.0	0.5
1.91	259.0	8.6	1.91	23.0	0.8
2.54	305.0	10.1	2.54	33.0	1.1
3.18	352.0	11.7	3.18	46.0	1.5
3.81	403.0	13.4	3.81	53.0	1.8
4.45	445.0	14.8	4.45	59.0	2.0
5.08	480.0	15.9	5.08	65.0	2.2
7.62	589.0	19.5	7.62	83.0	2.8
10.16		0.0	10.16		0.0

Load Vs Penetration for Soaked Condition

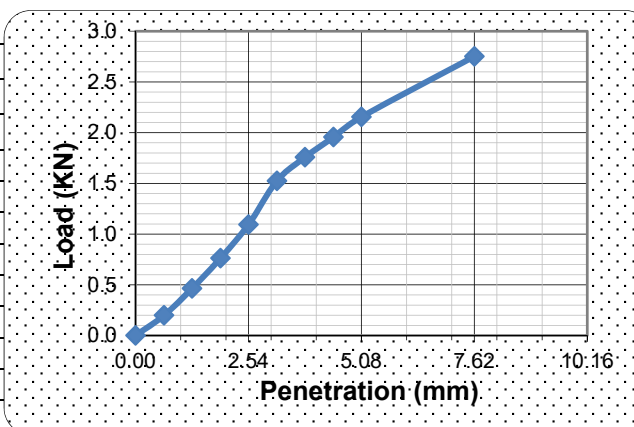

Dry CBR %			Soaked CBR %		
2.54mm	5.08mm	Corrected	2.54mm	5.08mm	Corrected
76.4	79.7	79.7	8.3	10.8	10.8

Swell Data		
Initial R.	Final R.	Swell (%)
10.79	16.92	5.27

SOAKED CBR VALUE DETERMINATION FROM LABORATORY DCP TEST FOR ADDIS ABABA RED CLAY SOIL

Sample No.	:3	Dry	Soaked
Mold No		26	26
Weight of wet soil + Mold (gm)		12974	13205
Weight of Mold (gm)		8907	8907
Weight of wet soil (gm)		4067	4298
Volume of Mold (cm ³)		2123	2123
Wet density of soil (gm/cm ³)		1.92	2.02
Dry density of soil (gm/cm ³)		1.51	1.49
Moisture Content			
Can No		3	3
Weight of wet soil + container (gm)		170.00	224.70
Weight of dry soil + container (gm)		141.70	175.10
Weight of container (gm)		35.90	35.90
Weight of moisture (gm)		28.30	49.60
Weight of dry soil (gm)		105.80	139.20
Moisture Content, % (m)		26.75	35.63

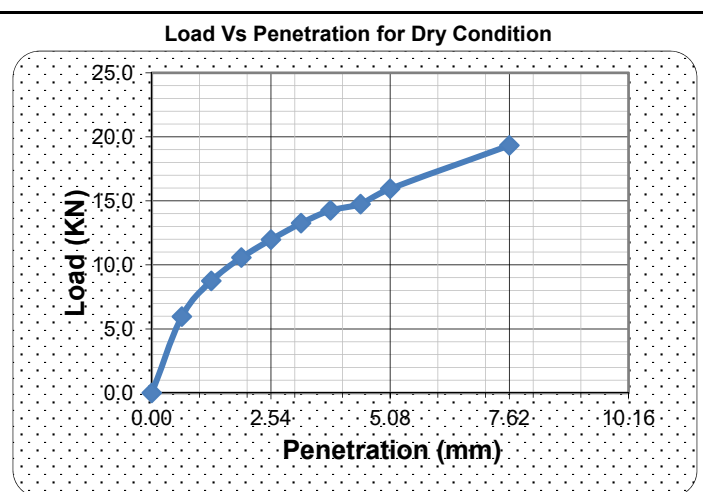

PENETRATION DATA					
					Ring Factor (KN/DIV)
					0.033153
Pen.(mm)	Dry		Soaked		
	Dial Reading	Load (KN)	Pen.(mm)	Dial Reading	Load (KN)
0.0		0.0	0.0		0.0
0.64	180.0	6.0	0.64	4.0	0.1
1.27	264.0	8.8	1.27	11.0	0.4
1.91	319.0	10.6	1.91	26.0	0.9
2.54	361.0	12.0	2.54	34.0	1.1
3.18	400.0	13.3	3.18	40.0	1.3
3.81	430.0	14.3	3.81	45.0	1.5
4.45	445.0	14.8	4.45	48.0	1.6
5.08	481.0	15.9	5.08	51.0	1.7
7.62	583.0	19.3	7.62	60.0	2.0
10.16		0.0	10.16		0.0

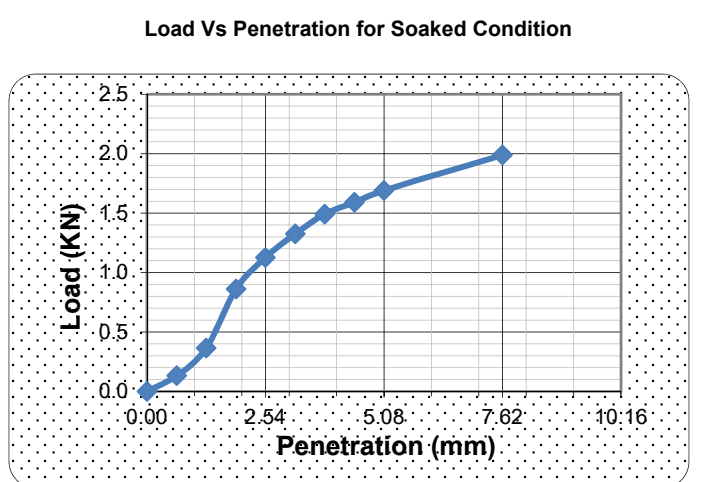

Dry CBR %			Soaked CBR %		
2.54mm	5.08mm	Corrected	2.54mm	5.08mm	Corrected
90.4	79.9	90.4	8.5	8.5	9.0

Swell Data		
Initial R.	Final R.	Swell (%)
2.69	7.79	4.38

SOAKED CBR VALUE DETERMINATION FROM LABORATORY DCP TEST FOR ADDIS ABABA RED CLAY SOIL

Sample No. :4		Dry		Soaked	
Mold No		22	20		
Weight of wet soil + Mold (gm)		12741	12946		
Weight of Mold (gm)		8619	8619		
Weight of wet soil (gm)		4122	4327		
Volume of Mold (cm ³)		2123	2123		
Wet density of soil (gm/cm ³)		1.94	2.04		
Dry density of soil (gm/cm ³)		1.53	1.53		
Moisture Content					
Can No		K	2		
Weight of wet soil + container (gm)		167.30	194.50		
Weight of dry soil + container (gm)		140.00	156.00		
Weight of container (gm)		37.90	38.80		
Weight of moisture (gm)		27.30	38.50		
Weight of dry soil (gm)		102.10	117.20		
Moisture Content, % (m)		26.74	32.85		
PENETRATION DATA					
		Ring Factor (KN/DIV)		0.033153	
Dry			Soaked		
Pen.(mm)	Dial Reading	Load (KN)	Pen.(mm)	Dial Reading	Load (KN)
0.0		0.0	0.0		0.0
0.64	59.0	2.0	0.64	5.0	0.2
1.27	158.0	5.2	1.27	10.0	0.3
1.91	249.0	8.3	1.91	20.0	0.7
2.54	311.0	10.3	2.54	34.0	1.1
3.18	363.0	12.0	3.18	44.0	1.5
3.81	407.0	13.5	3.81	53.0	1.8
4.45	442.0	14.7	4.45	57.0	1.9
5.08	466.0	15.4	5.08	63.0	2.1
7.62	543.0	18.0	7.62	76.0	2.5
10.16		0.0	10.16		0.0
Dry CBR %			Soaked CBR %		
2.54mm	5.08mm	Corrected	2.54mm	5.08mm	Corrected
77.9	77.4	77.9	8.5	10.5	11.5
Swell Data					
Initial R.		Final R.		Swell (%)	
16.28		21.89		4.82	

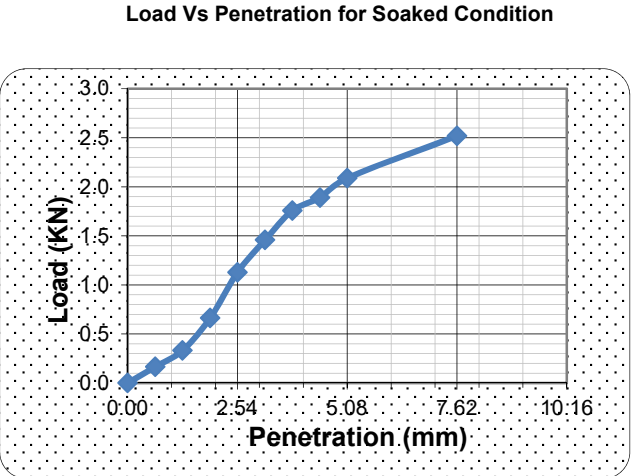
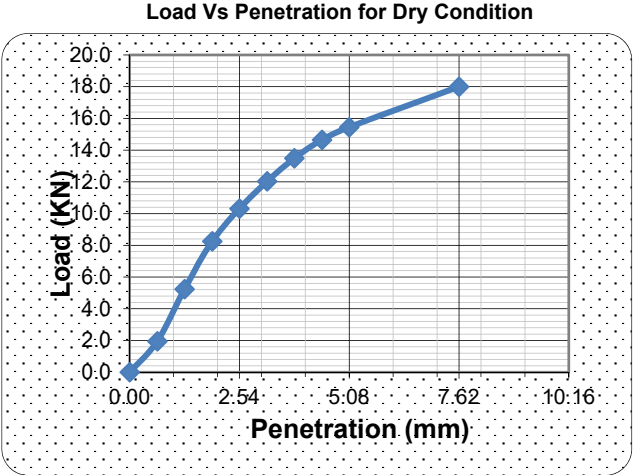

SOAKED CBR VALUE DETERMINATION FROM LABORATORY DCP TEST FOR ADDIS ABABA RED CLAY SOIL

Sample No.	:5	Dry	Soaked
Mold No	7	7	7
Weight of wet soil + Mold (gm)	12689	12934	12934
Weight of Mold (gm)	8644	8644	8644
Weight of wet soil (gm)	4045	4290	4290
Volume of Mold (cm ³)	2123	2123	2123
Wet density of soil (gm/cm ³)	1.91	2.02	2.02
Dry density of soil (gm/cm ³)	1.54	1.55	1.55
Moisture Content			
Can No	21	J	J
Weight of wet soil + container (gm)	186.00	206.70	206.70
Weight of dry soil + container (gm)	157.60	167.20	167.20
Weight of container (gm)	38.20	36.00	36.00
Weight of moisture (gm)	28.40	39.50	39.50
Weight of dry soil (gm)	119.40	131.20	131.20
Moisture Content, % (m)	23.79	30.11	30.11

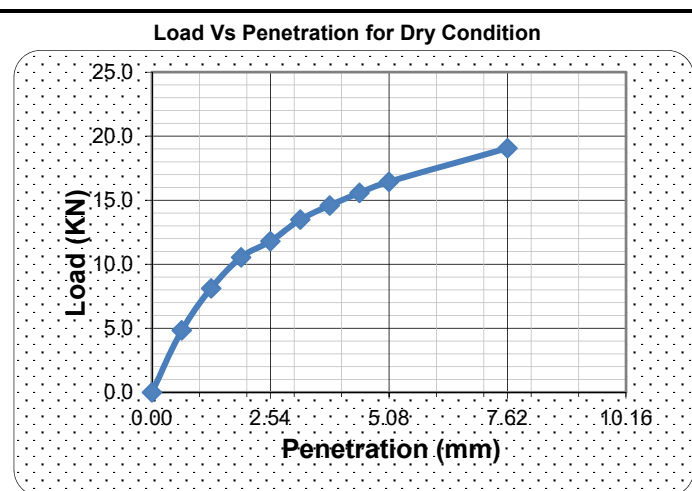

PENETRATION DATA			
		Ring Factor (KN/DIV)	0.033153

Pen.(mm)	Dry		Soaked		
	Dial	Load	Pen.(mm)	Dial	Load
	Reading	(KN)		Reading	(KN)
0.0		0.0	0.0		0.0
0.64	146.0	4.8	0.64	1.0	0.0
1.27	245.0	8.1	1.27	4.0	0.1
1.91	318.0	10.5	1.91	8.0	0.3
2.54	356.0	11.8	2.54	12.0	0.4
3.18	407.0	13.5	3.18	21.0	0.7
3.81	440.0	14.6	3.81	30.0	1.0
4.45	470.0	15.6	4.45	36.0	1.2
5.08	496.0	16.4	5.08	43.0	1.4
7.62	575.0	19.1	7.62	58.0	1.9
10.16		0.0	10.16		0.0

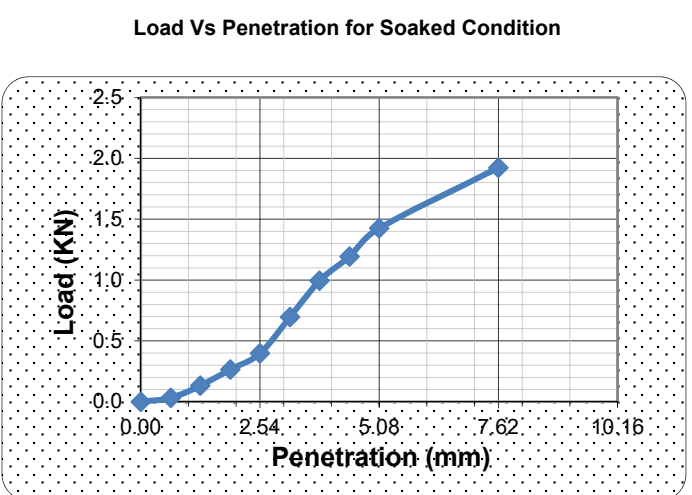

Dry CBR %			Soaked CBR %		
2.54mm	5.08mm	Corrected	2.54mm	5.08mm	Corrected
89.1	82.4	89.1	3.0	7.1	9.0

Swell Data		
Initial R.	Final R.	Swell (%)
7.68	15.68	6.87

SOAKED CBR VALUE DETERMINATION FROM LABORATORY DCP TEST FOR ADDIS ABABA RED CLAY SOIL

Sample No.	:6		Dry	Soaked		
Mold No			27	23		
Weight of wet soil + Mold (gm)			13023	13148		
Weight of Mold (gm)			8814	8814		
Weight of wet soil (gm)			4209	4334		
Volume of Mold (cm ³)			2123	2123		
Wet density of soil (gm/cm ³)			1.98	2.04		
Dry density of soil (gm/cm ³)			1.58	1.55		
Moisture Content						
Can No			17	K		
Weight of wet soil + container (gm)			239.30	196.20		
Weight of dry soil + container (gm)			198.00	158.10		
Weight of container (gm)			36.60	37.90		
Weight of moisture (gm)			41.30	38.10		
Weight of dry soil (gm)			161.40	120.20		
Moisture Content, % (m)			25.59	31.70		
PENETRATION DATA						
			Ring Factor (KN/DIV)		0.033153	
	Dry		Soaked			
Pen.(mm)	Dial	Load	Pen.(mm)	Dial	Load	
	Reading	(KN)		Reading	(KN)	
0.0		0.0	0.0		0.0	
0.64	122.0	4.0	0.64	6.0	0.2	
1.27	206.0	6.8	1.27	16.0	0.5	
1.91	280.0	9.3	1.91	25.0	0.8	
2.54	329.0	10.9	2.54	32.0	1.1	
3.18	378.0	12.5	3.18	38.0	1.3	
3.81	425.0	14.1	3.81	42.0	1.4	
4.45	460.0	15.3	4.45	45.0	1.5	
5.08	495.0	16.4	5.08	49.0	1.6	
7.62	577.0	19.1	7.62	59.0	2.0	
10.16		0.0	10.16		0.0	
Dry CBR %			Soaked CBR %			
2.54mm	5.08mm	Corrected	2.54mm	5.08mm	Corrected	
82.4	82.2	82.4	8.0	8.1	8.1	
Swell Data						
Initial R.		Final R.		Swell (%)		
1.7		8.92		6.20		

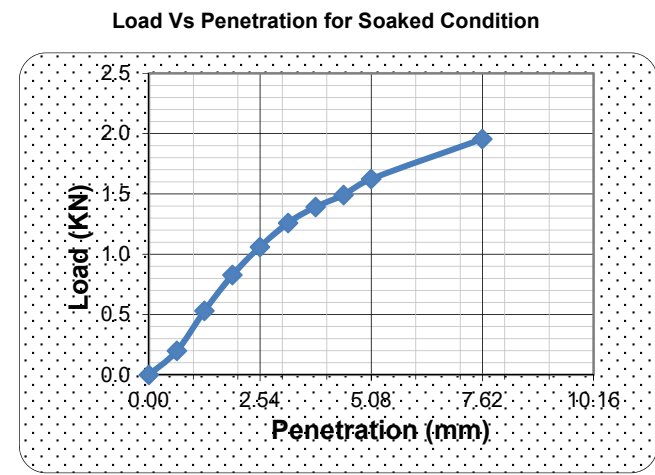
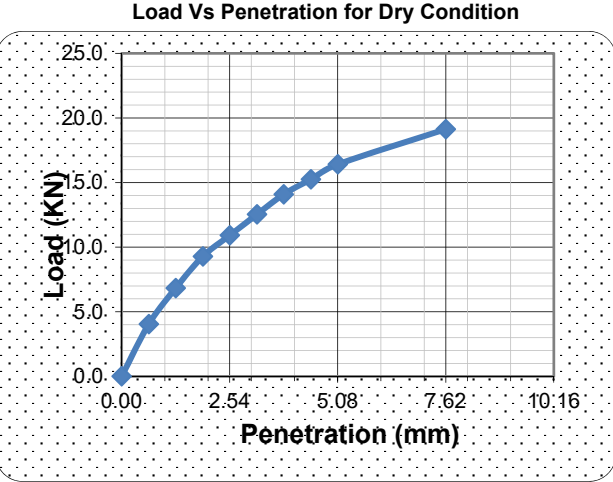

SOAKED CBR VALUE DETERMINATION FROM LABORATORY DCP TEST FOR ADDIS ABABA RED CLAY SOIL

Sample No.	:7	Dry	Soaked		
Mould No		17	17		
Weight of wet soil + mould (gm)		10551	10911		
Weight of mould (gm)		6369	6369		
Weight of wet soil (gm)		4182	4542		
Volume of mould (cm ³)		2123	2123		
Wet density of soil (gm/cm ³)		1.97	2.14		
Dry density of soil (gm/cm ³)		1.60	1.59		
Moisture Content					
Can No		BE	C		
Weight of wet soil + container (gm)		198.60	206.90		
Weight of dry soil + container (gm)		168.50	163.40		
Weight of container (gm)		36.70	36.50		
Weight of moisture (gm)		30.10	43.50		
Weight of dry soil (gm)		131.80	126.90		
Moisture Content, % (m)		22.84	34.28		
PENETRATION DATA					
		Ring Factor (KN/DIV)	0.033153		
		Dry	Soaked		
Pen.(mm)	Dial Reading	Load (KN)	Pen.(mm)	Dial Reading	Load (KN)
0.0		0.0	0.0		0.0
0.64	41.0	1.4	0.64	4.0	0.1
1.27	134.0	4.4	1.27	9.0	0.3
1.91	220.0	7.3	1.91	15.0	0.5
2.54	282.0	9.3	2.54	21.0	0.7
3.18	330.0	10.9	3.18	26.0	0.9
3.81	370.0	12.3	3.81	28.0	0.9
4.45	400.0	13.3	4.45	31.0	1.0
5.08	432.0	14.3	5.08	34.0	1.1
7.62	512.0	17.0	7.62	42.0	1.4
10.16		0.0	10.16		0.0
Dry CBR %			Soaked CBR %		
2.54mm	5.08mm	Corrected	2.54mm	5.08mm	Corrected
70.6	71.8	75.2	5.3	5.6	5.6

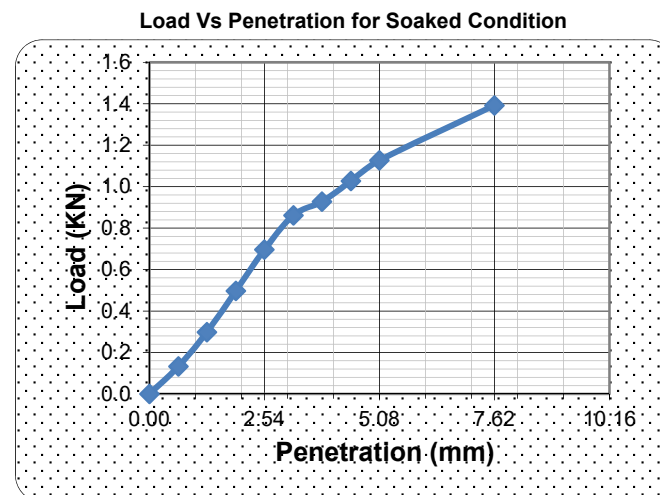
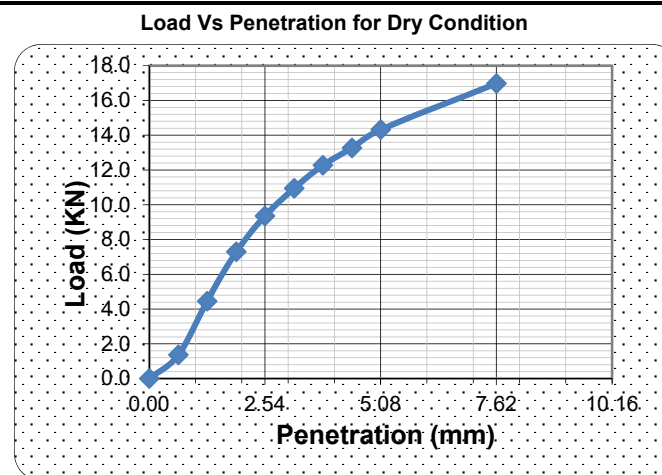

Swell Data		
Initial R.	Final R.	Swell (%)
17.74	23.26	4.74

SOAKED CBR VALUE DETERMINATION FROM LABORATORY DCP TEST FOR ADDIS ABABA RED CLAY SOIL

Sample No. :8	Dry	Soaked
Mold No	24	2
Weight of wet soil + Mold (gm)	12469	12846
Weight of Mold (gm)	8616	8642
Weight of wet soil (gm)	3853	4204
Volume of Mold (cm ³)	2123	2123
Wet density of soil (gm/cm ³)	1.81	1.98
Dry density of soil (gm/cm ³)	1.46	1.44
Moisture Content		
Can No	13	25
Weight of wet soil + container (gm)	140.70	207.60
Weight of dry soil + container (gm)	120.40	160.80
Weight of container (gm)	36.70	36.70
Weight of moisture (gm)	20.30	46.80
Weight of dry soil (gm)	83.70	124.10
Moisture Content, % (m)	24.25	37.71

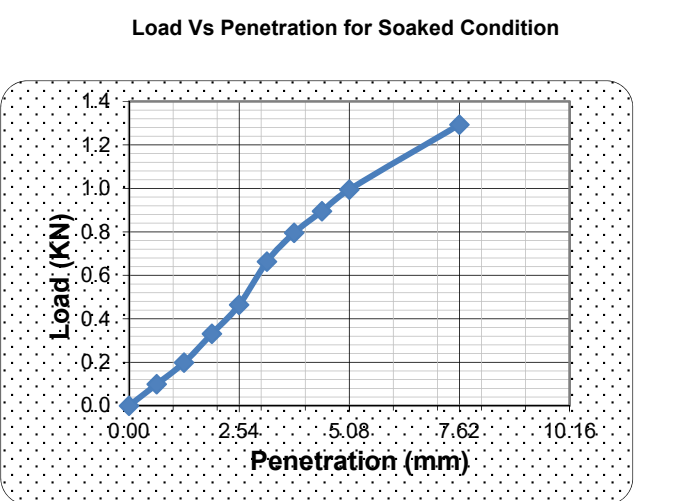
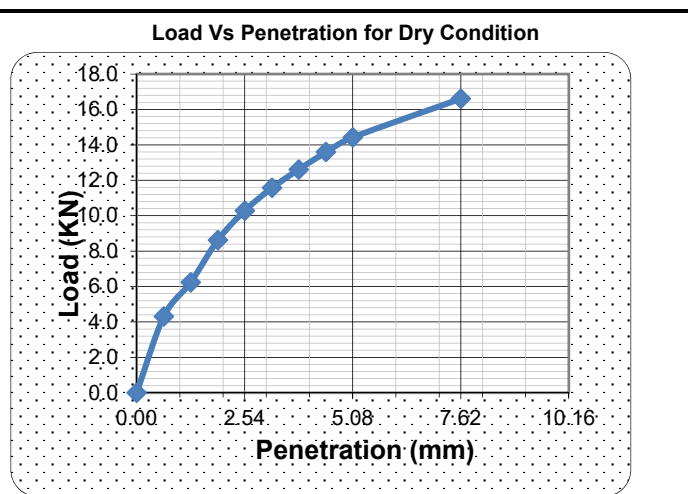

PENETRATION DATA	
Ring Factor (KN/DIV)	0.033153

Pen.(mm)	Dry		Soaked		
	Dial	Load	Pen.(mm)	Dial	Load
	Reading	(KN)		Reading	(KN)
0.0		0.0	0.0		0.0
0.64	130.0	4.3	0.64	3.0	0.1
1.27	188.0	6.2	1.27	6.0	0.2
1.91	260.0	8.6	1.91	10.0	0.3
2.54	310.0	10.3	2.54	14.0	0.5
3.18	349.0	11.6	3.18	20.0	0.7
3.81	380.0	12.6	3.81	24.0	0.8
4.45	410.0	13.6	4.45	27.0	0.9
5.08	435.0	14.4	5.08	30.0	1.0
7.62	501.0	16.6	7.62	39.0	1.3
10.16		0.0	10.16		0.0

Dry CBR %			Soaked CBR %		
2.54mm	5.08mm	Corrected	2.54mm	5.08mm	Corrected
77.6	72.3	77.6	3.5	5.0	5.0

Swell Data		
Initial R.	Final R.	Swell (%)
0.27	7.25	6.00

SOAKED CBR VALUE DETERMINATION FROM LABORATORY DCP TEST FOR ADDIS ABABA RED CLAY SOIL

Sample No.	:9	Dry	Soaked
Mold No		29	6
Weight of wet soil + Mold (gm)		10926	13395
Weight of Mold (gm)		6813	8917
Weight of wet soil (gm)		4113	4478
Volume of Mold (cm ³)		2123	2123
Wet density of soil (gm/cm ³)		1.94	2.11
Dry density of soil (gm/cm ³)		1.55	1.53
Moisture Content			
Can No		P	4
Weight of wet soil + container (gm)		182.50	193.50
Weight of dry soil + container (gm)		153.60	150.10
Weight of container (gm)		37.70	35.70
Weight of moisture (gm)		28.90	43.40
Weight of dry soil (gm)		115.90	114.40
Moisture Content, % (m)		24.94	37.94

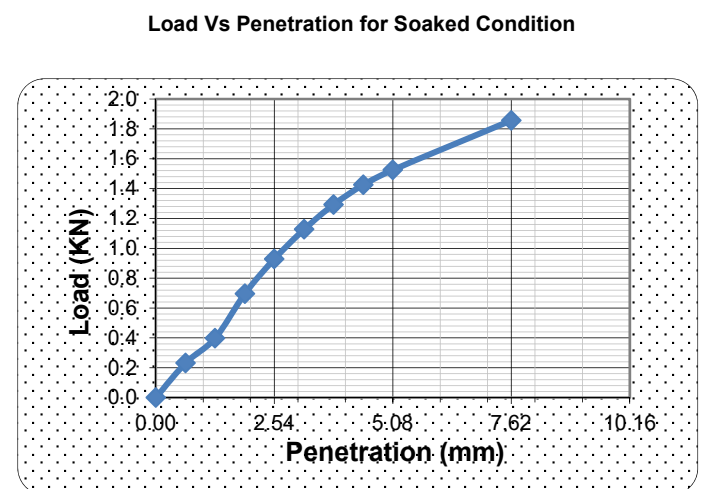
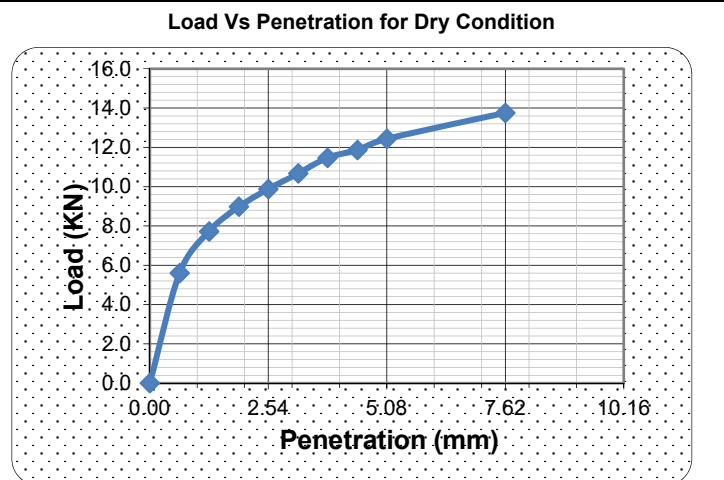

PENETRATION DATA					
			Ring Factor (KN/DIV)	0.033153	
Pen.(mm)	Dry		Soaked		
	Dial Reading	Load (KN)	Pen.(mm)	Dial Reading	Load (KN)
0.0		0.0	0.0		0.0
0.64	169.0	5.6	0.64	7.0	0.2
1.27	233.0	7.7	1.27	12.0	0.4
1.91	271.0	9.0	1.91	21.0	0.7
2.54	298.0	9.9	2.54	28.0	0.9
3.18	322.0	10.7	3.18	34.0	1.1
3.81	346.0	11.5	3.81	39.0	1.3
4.45	358.0	11.9	4.45	43.0	1.4
5.08	375.0	12.4	5.08	46.0	1.5
7.62	415.0	13.8	7.62	56.0	1.9
10.16		0.0	10.16		0.0
Dry CBR %			Soaked CBR %		
2.54mm	5.08mm	Corrected	2.54mm	5.08mm	Corrected
74.6	62.3	74.6	7.0	7.6	7.6

Swell Data		
Initial R.	Final R.	Swell (%)
5.06	12.09	6.04

SOAKED CBR VALUE DETERMINATION FROM LABORATORY DCP TEST FOR ADDIS ABABA RED CLAY SOIL

Sample No.	:10		Dry	Soaked
Mold No	19		1	
Weight of wet soil + Mold (gm)	12845	13145		
Weight of Mold (gm)	8846	8824		
Weight of wet soil (gm)	3999	4321		
Volume of Mold (cm ³)	2123	2123		
Wet density of soil (gm/cm ³)	1.88	2.04		
Dry density of soil (gm/cm ³)	1.52	1.50		
Moisture Content				
Can No	v	30		
Weight of wet soil + container (gm)	217.30	212.10		
Weight of dry soil + container (gm)	182.20	166.20		
Weight of container (gm)	36.70	36.60		
Weight of moisture (gm)	35.10	45.90		
Weight of dry soil (gm)	145.50	129.60		
Moisture Content, % (m)	24.12	35.42		

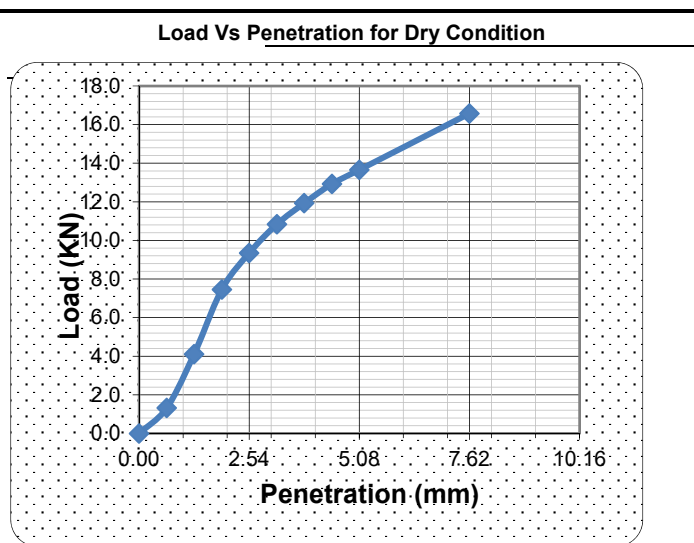

PENETRATION DATA

			Ring Factor (KN/DIV)	0.033153	
	Dry		Soaked		
Pen.(mm)	Dial	Load (KN)	Pen.(mm)	Dial	Load (KN)
	Reading			Reading	
0.0		0.0	0.0		0.0
0.64	40.0	1.3	0.64	5.0	0.2
1.27	124.0	4.1	1.27	13.0	0.4
1.91	225.0	7.5	1.91	21.0	0.7
2.54	282.0	9.3	2.54	30.0	1.0
3.18	327.0	10.8	3.18	39.0	1.3
3.81	360.0	11.9	3.81	44.0	1.5
4.45	390.0	12.9	4.45	49.0	1.6
5.08	412.0	13.7	5.08	52.0	1.7
7.62	500.0	16.6	7.62	62.0	2.1
10.16		0.0	10.16		0.0

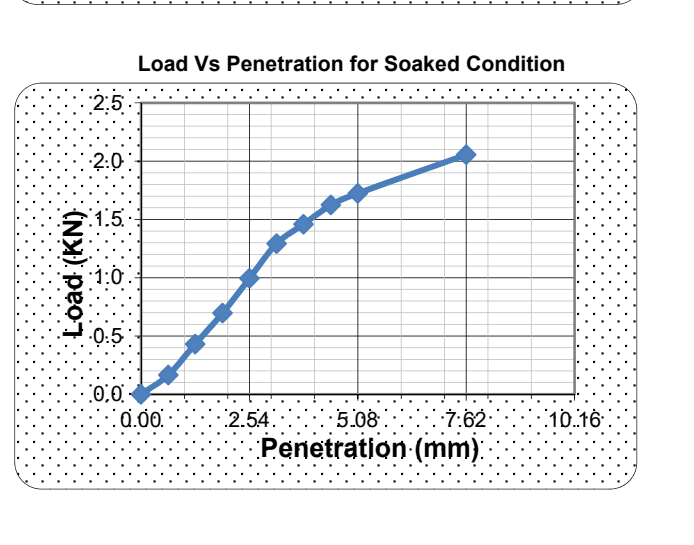

Dry CBR %			Soaked CBR %		
2.54mm	5.08mm	Corrected	2.54mm	5.08mm	Corrected
70.6	68.4	78.5	7.5	8.6	8.6

Swell Data		
Initial R.	Final R.	Swell (%)
9.6	15.33	4.92

SOAKED CBR VALUE DETERMINATION FROM LABORATORY DCP TEST FOR ADDIS ABABA RED CLAY SOIL

Sample No.	:11	Dry	Soaked		
Mold No		5	5		
Weight of wet soil + Mold (gm)		12687	13042		
Weight of Mold (gm)		8793	8793		
Weight of wet soil (gm)		3894	4249		
Volume of Mold (cm ³)		2123	2123		
Wet density of soil (gm/cm ³)		1.83	2.00		
Dry density of soil (gm/cm ³)		1.53	1.52		
Moisture Content					
Can No		26	5		
Weight of wet soil + container (gm)		170.70	220.40		
Weight of dry soil + container (gm)		148.50	176.50		
Weight of container (gm)		35.40	36.60		
Weight of moisture (gm)		22.20	43.90		
Weight of dry soil (gm)		113.10	139.90		
Moisture Content, % (m)		19.63	31.38		
PENETRATION DATA					
			Ring Factor (KN/DIV)		0.033153
Dry			Soaked		
Pen.(mm)	Dial Reading	Load (KN)	Pen.(mm)	Dial Reading	Load (KN)
0.0		0.0	0.0		0.0
0.64	130.0	4.3	0.64	5.0	0.2
1.27	204.0	6.8	1.27	10.0	0.3
1.91	267.0	8.9	1.91	14.0	0.5
2.54	315.0	10.4	2.54	17.0	0.6
3.18	357.0	11.8	3.18	20.0	0.7
3.81	390.0	12.9	3.81	24.0	0.8
4.45	420.0	13.9	4.45	26.0	0.9
5.08	444.0	14.7	5.08	27.0	0.9
7.62	509.0	16.9	7.62	36.0	1.2
10.16		0.0	10.16		0.0
Dry CBR %			Soaked CBR %		
2.54mm	5.08mm	Corrected	2.54mm	5.08mm	Corrected
78.9	73.7	78.9	4.3	4.5	4.5

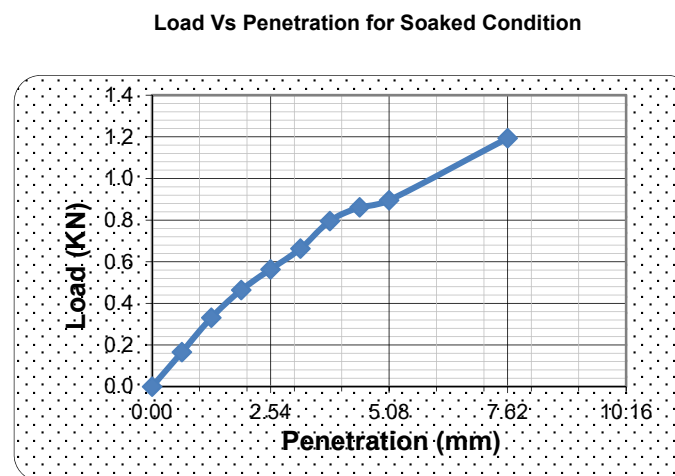
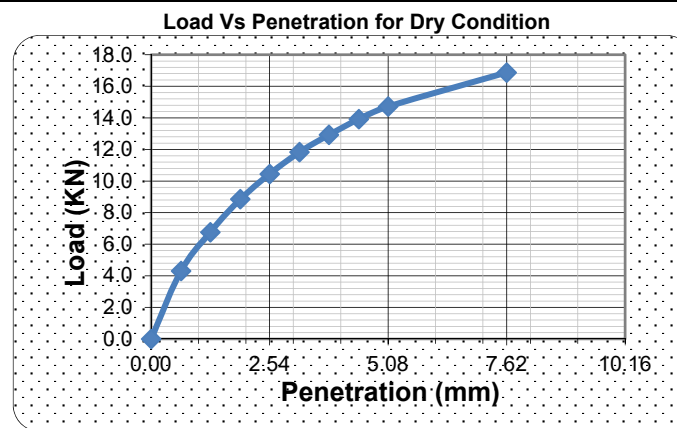

Swell Data		
Initial R.	Final R.	Swell (%)
16.96	19.97	2.59

SOAKED CBR VALUE DETERMINATION FROM LABORATORY DCP TEST FOR ADDIS ABABA RED CLAY SOIL

Sample No.	:12	Dry	Soaked		
mold No	31	4			
Weight of wet soil + mold (gm)	10598	10743			
Weight of mold (gm)	6438	6449			
Weight of wet soil (gm)	4160	4294			
Volume of mold (cm ³)	2123	2123			
Wet density of soil (gm/cm ³)	1.96	2.02			
Dry density of soil (gm/cm ³)	1.62	1.61			
Moisture Content					
Can No	9	7			
Weight of wet soil + container (gm)	175.40	200.10			
Weight of dry soil + container (gm)	151.40	166.80			
Weight of container (gm)	38.00	36.70			
Weight of moisture (gm)	24.00	33.30			
Weight of dry soil (gm)	113.40	130.10			
Moisture Content, % (m)	21.16	25.60			
PENETRATION DATA					
			Ring Factor (KN/DIV)	0.033153	
Dry			Soaked		
Pen.(mm)	Dial	Load (KN)	Pen.(mm)	Dial	Load (KN)
	Reading	(KN)		Reading	(KN)
	Reading	Reading	Reading	(KN)	(KN)
0.0		0.0	0.0		0.0
0.64	93.0	3.1	0.64	16.0	0.5
1.27	143.0	4.7	1.27	34.0	1.1
1.91	179.0	5.9	1.91	49.0	1.6
2.54	212.0	7.0	2.54	64.0	2.1
3.18	243.0	8.1	3.18	74.0	2.5
3.81	270.0	9.0	3.81	82.0	2.7
4.45	294.0	9.7	4.45	87.0	2.9
5.08	312.0	10.3	5.08	90.0	3.0
7.62	398.0	13.2	7.62	95.0	3.1
Dry CBR %			Soaked CBR %		
2.54mm	5.08mm	Corrected	2.54mm	5.08mm	Corrected
53.1	51.8	53.1	16.0	14.9	16.0

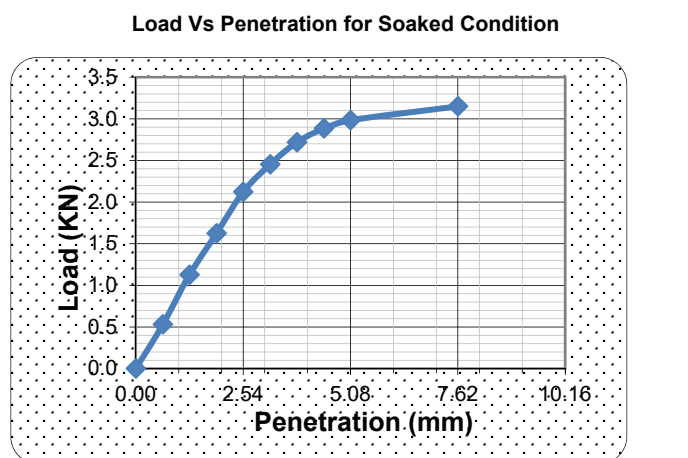
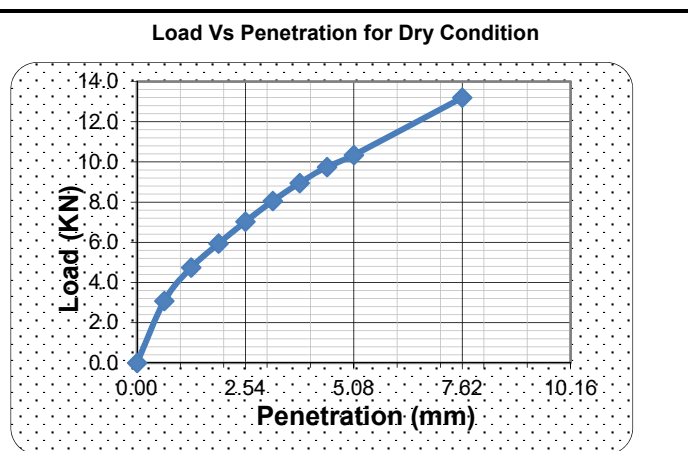

SOAKED CBR VALUE DETERMINATION FROM LABORATORY DCP TEST FOR ADDIS ABABA RED CLAY SOIL

Sample No.	:13		Dry	Soaked	
	mold No		14	24	
	Weight of wet soil + mold (gm)		10883	12912	
	Weight of mold (gm)		6717	8616	
	Weight of wet soil (gm)		4166	4296	
	Volume of mold (cm ³)		2123	2123	
	Wet density of soil (gm/cm ³)		1.96	2.02	
	Dry density of soil (gm/cm ³)		1.57	1.58	
	Moisture Content				
	Can No		AA	O	
	Weight of wet soil + container (gm)		162.80	227.20	
	Weight of dry soil + container (gm)		138.00	186.00	
	Weight of container (gm)		38.70	37.80	
	Weight of moisture (gm)		24.80	41.20	
	Weight of dry soil (gm)		99.30	148.20	
	Moisture Content, % (m)		24.97	27.80	
PENETRATION DATA					
			Ring Factor (KN/DIV)		0.033153
Dry			Soaked		
Pen.(mm)	Dial	Load	Pen.(mm)	Dial	Load
	Reading	(KN)		Reading	(KN)
0.0		0.0	0.0		0.0
0.64	72.0	2.4	0.64	18.0	0.6
1.27	120.0	4.0	1.27	34.0	1.1
1.91	151.0	5.0	1.91	50.0	1.7
2.54	170.0	5.6	2.54	64.0	2.1
3.18	182.0	6.0	3.18	76.0	2.5
3.81	193.0	6.4	3.81	82.0	2.7
4.45	205.0	6.8	4.45	88.0	2.9
5.08	212.0	7.0	5.08	92.0	3.1
7.62	238.0	7.9	7.62	100.0	3.3
Dry CBR %			Soaked CBR %		
2.54mm	5.08mm	Corrected	2.54mm	5.08mm	Corrected
42.6	35.2	42.6	16.0	15.3	16.0

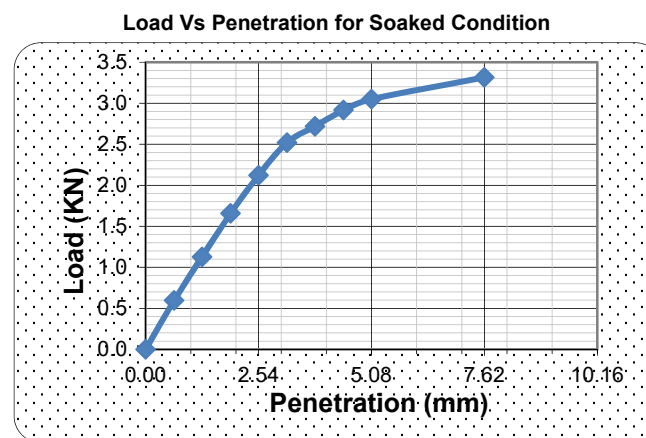
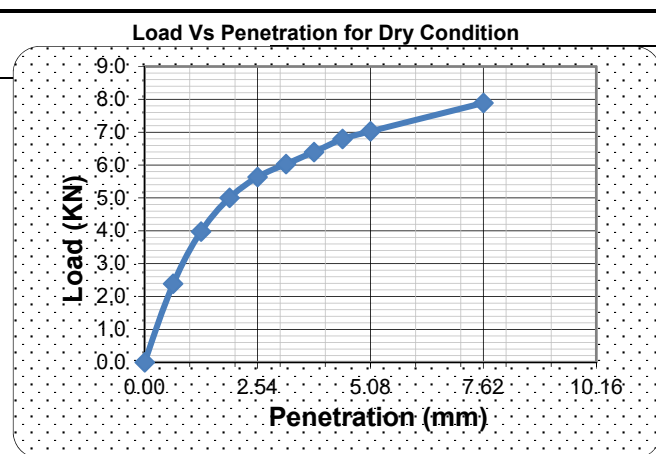

Swell Data		
Initial R.	Final R.	Swell (%)
1.19	2.84	1.42

SOAKED CBR VALUE DETERMINATION FROM LABORATORY DCP TEST FOR ADDIS ABABA RED CLAY SOIL

Sample No.	:14	Dry	Soaked		
mold No		22	2		
Weight of wet soil + mold (gm)		10396	12879		
Weight of mold (gm)		6279	8642		
Weight of wet soil (gm)		4117	4237		
Volume of mold (cm ³)		2123	2123		
Wet density of soil (gm/cm ³)		1.94	2.00		
Dry density of soil (gm/cm ³)		1.56	1.54		
Moisture Content					
Can No		R	8		
Weight of wet soil + container (gm)		207.50	275.10		
Weight of dry soil + container (gm)		173.70	221.00		
Weight of container (gm)		36.70	38.20		
Weight of moisture (gm)		33.80	54.10		
Weight of dry soil (gm)		137.00	182.80		
Moisture Content, % (m)		24.67	29.60		
PENETRATION DATA					
			Ring Factor (KN/DIV)	0.033153	
Dry			Soaked		
Pen.(mm)	Dial	Load	Pen.(mm)	Dial	Load
	Reading	(KN)		Reading	(KN)
	Reading	Reading	Reading	(KN)	(KN)
0.0		0.0	0.0		0.0
0.64	40.0	1.3	0.64	14.0	0.5
1.27	80.0	2.7	1.27	34.0	1.1
1.91	120.0	4.0	1.91	50.0	1.7
2.54	150.0	5.0	2.54	63.0	2.1
3.18	175.0	5.8	3.18	75.0	2.5
3.81	200.0	6.6	3.81	80.0	2.7
4.45	220.0	7.3	4.45	88.0	2.9
5.08	244.0	8.1	5.08	94.0	3.1
7.62	300.0	9.9	7.62	110.0	3.6
Dry CBR %			Soaked CBR %		
2.54mm	5.08mm	Corrected	2.54mm	5.08mm	Corrected
37.6	40.5	40.5	15.8	15.6	15.8

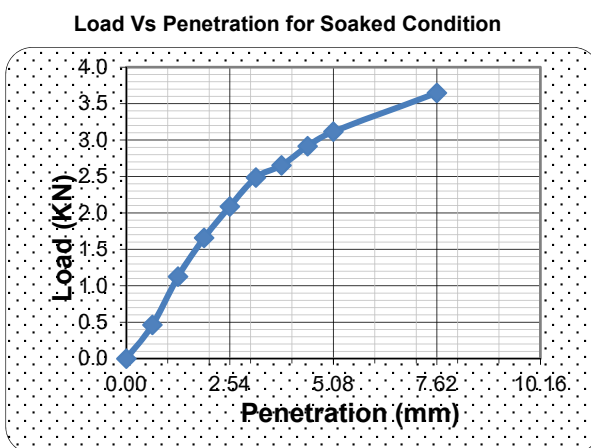
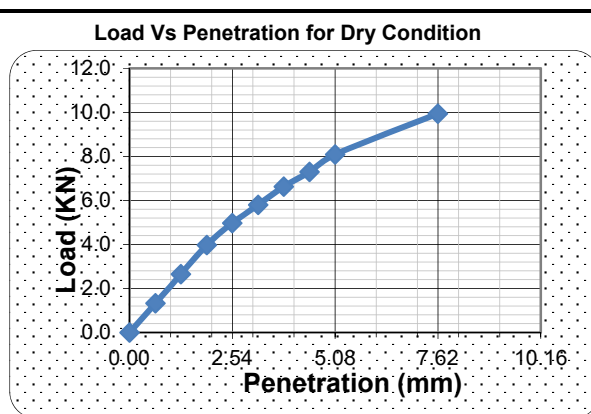

Swell Data		
Initial R.	Final R.	Swell (%)
5.96	5.47	-0.42

SOAKED CBR VALUE DETERMINATION FROM LABORATORY DCP TEST FOR ADDIS ABABA RED CLAY SOIL

Sample No.	:15	Dry	Soaked		
mold No		9	9		
Weight of wet soil + mold (gm)		10503	10572		
Weight of mold (gm)		6342	6342		
Weight of wet soil (gm)		4161	4230		
Volume of mold (cm ³)		2123	2123		
Wet density of soil (gm/cm ³)		1.96	1.99		
Dry density of soil (gm/cm ³)		1.58	1.58		
Moisture Content					
Can No		15	19		
Weight of wet soil + container (gm)		181.40	185.20		
Weight of dry soil + container (gm)		153.50	154.60		
Weight of container (gm)		37.00	35.60		
Weight of moisture (gm)		27.90	30.60		
Weight of dry soil (gm)		116.50	119.00		
Moisture Content, % (m)		23.95	25.71		
PENETRATION DATA					
			Ring Factor (KN/DIV)		0.033153
Dry			Soaked		
Pen.(mm)	Dial	Load	Pen.(mm)	Dial	Load
	Reading	(KN)		Reading	(KN)
0.0		0.0	0.0		0.0
0.64	51.0	1.7	0.64	19.0	0.6
1.27	101.0	3.3	1.27	40.0	1.3
1.91	150.0	5.0	1.91	52.0	1.7
2.54	198.0	6.6	2.54	63.0	2.1
3.18	230.0	7.6	3.18	69.0	2.3
3.81	245.0	8.1	3.81	76.0	2.5
4.45	255.0	8.5	4.45	81.0	2.7
5.08	264.0	8.8	5.08	85.0	2.8
7.62	285.0	9.4	7.62	100.0	3.3
Dry CBR %			Soaked CBR %		
2.54mm	5.08mm	Corrected	2.54mm	5.08mm	Corrected
49.6	43.8	49.6	15.8	14.1	15.8

Penetration (mm)	Load (KN)
0.00	0.0
0.64	1.7
1.27	3.3
1.91	5.0
2.54	6.6
3.18	7.6
3.81	8.1
4.45	8.5
5.08	8.8
7.62	9.4

Penetration (mm)	Load (KN)
0.00	0.0
0.64	0.6
1.27	1.3
1.91	1.7
2.54	2.1
3.18	2.3
3.81	2.5
4.45	2.7
5.08	2.8
7.62	3.3

Swell Data		
Initial R.	Final R.	Swell (%)
6.74	7.16	0.36

SOAKED CBR VALUE DETERMINATION FROM LABORATORY DCP TEST FOR ADDIS ABABA RED CLAY SOIL

Sample No.	:17		Dry	Soaked	
	mold No		9	28	
	Weight of wet soil + mold (gm)		10516	13218	
	Weight of mold (gm)		6342	8858	
	Weight of wet soil (gm)		4174	4360	
	Volume of mold (cm ³)		2123	2123	
	Wet density of soil (gm/cm ³)		1.97	2.05	
	Dry density of soil (gm/cm ³)		1.62	1.63	
	Moisture Content				
	Can No		N	9	
	Weight of wet soil + container (gm)		198.70	190.10	
	Weight of dry soil + container (gm)		170.00	159.00	
	Weight of container (gm)		36.20	38.00	
	Weight of moisture (gm)		28.70	31.10	
	Weight of dry soil (gm)		133.80	121.00	
	Moisture Content, % (m)		21.45	25.70	
PENETRATION DATA					
			Ring Factor (KN/DIV)		0.033153
Dry			Soaked		
Pen.(mm)	Dial	Load	Pen.(mm)	Dial	Load
	Reading	(KN)		Reading	(KN)
0.0		0.0	0.0		0.0
0.64	76.0	2.5	0.64	18.0	0.6
1.27	150.0	5.0	1.27	33.0	1.1
1.91	203.0	6.7	1.91	48.0	1.6
2.54	250.0	8.3	2.54	62.0	2.1
3.18	284.0	9.4	3.18	74.0	2.5
3.81	316.0	10.5	3.81	82.0	2.7
4.45	340.0	11.3	4.45	89.0	3.0
5.08	360.0	11.9	5.08	92.0	3.1
7.62	435.0	14.4	7.62	102.0	3.4
Dry CBR %			Soaked CBR %		
2.54mm	5.08mm	Corrected	2.54mm	5.08mm	Corrected
62.6	59.8	62.6	15.5	15.3	15.5

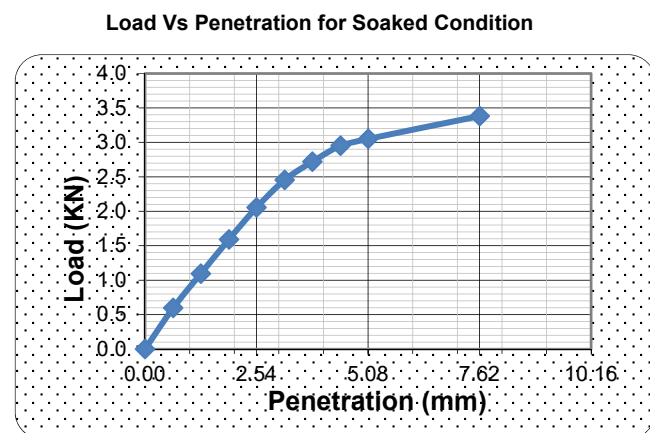
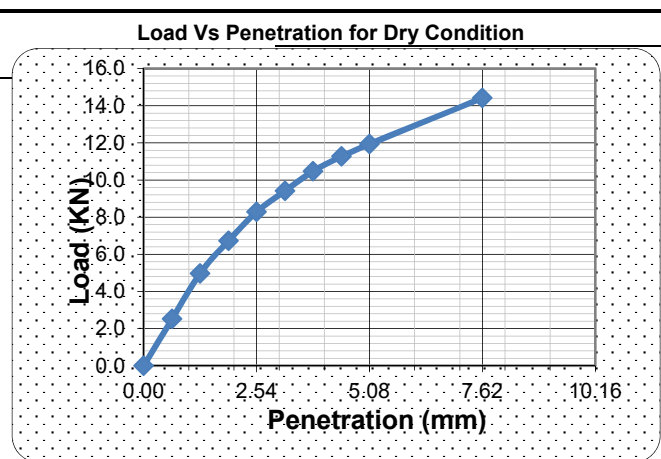

Swell Data		
Initial R.	Final R.	Swell (%)
3.92	5.48	1.34

SOAKED CBR VALUE DETERMINATION FROM LABORATORY DCP TEST FOR ADDIS ABABA RED CLAY SOIL

Sample No.	:18	Dry	Soaked
mold No		24	18
Weight of wet soil + mold (gm)		12708	12922
Weight of mold (gm)		8616	8636
Weight of wet soil (gm)		4092	4286
Volume of mold (cm ³)		2123	2123
Wet density of soil (gm/cm ³)		1.93	2.02
Dry density of soil (gm/cm ³)		1.58	1.59
Moisture Content			
Can No		14	E
Weight of wet soil + container (gm)		204.20	220.20
Weight of dry soil + container (gm)		174.60	180.90
Weight of container (gm)		38.00	36.90
Weight of moisture (gm)		29.60	39.30
Weight of dry soil (gm)		136.60	144.00
Moisture Content, % (m)		21.67	27.29

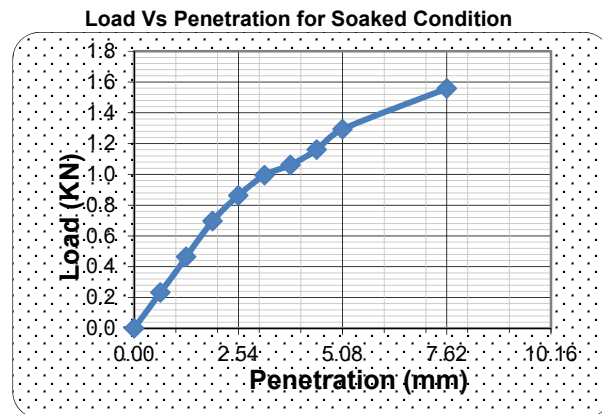
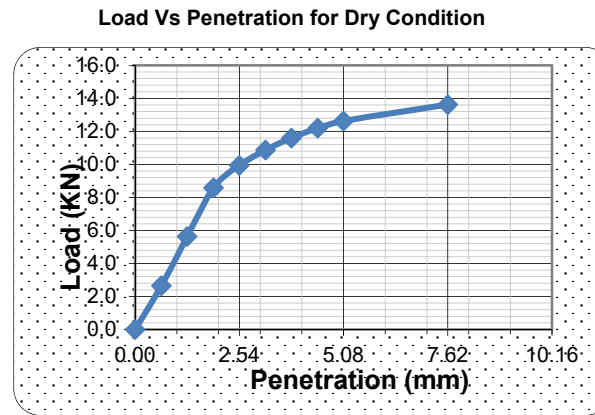

PENETRATION DATA					
			Ring Factor (KN/DIV)	0.033153	
Dry			Soaked		
Pen.(mm)	Dial Reading	Load (KN)	Pen.(mm)	Dial Reading	Load (KN)
0.0		0.0	0.0		0.0
0.64	80.0	2.7	0.64	7.0	0.2
1.27	170.0	5.6	1.27	14.0	0.5
1.91	259.0	8.6	1.91	21.0	0.7
2.54	300.0	9.9	2.54	26.0	0.9
3.18	328.0	10.9	3.18	30.0	1.0
3.81	350.0	11.6	3.81	32.0	1.1
4.45	368.0	12.2	4.45	35.0	1.2
5.08	381.0	12.6	5.08	39.0	1.3
7.62	411.0	13.6	7.62	47.0	1.6
Dry CBR %			Soaked CBR %		
2.54mm	5.08mm	Corrected	2.54mm	5.08mm	Corrected
75.1	63.3	75.1	6.5	6.5	6.5

Swell Data		
Initial R.	Final R.	Swell (%)
7.86	14.2	5.45

SOAKED CBR VALUE DETERMINATION FROM LABORATORY DCP TEST FOR ADDIS ABABA RED CLAY SOIL

Sample No. :19		Dry	Soaked			
mold No		28	28			
Weight of wet soil + mold (gm)		13106	13275			
Weight of mold (gm)		8858	8858			
Weight of wet soil (gm)		4248	4417			
Volume of mold (cm ³)		2123	2123			
Wet density of soil (gm/cm ³)		2.00	2.08			
Dry density of soil (gm/cm ³)		1.62	1.62			
Moisture Content						
Can No		x	L			
Weight of wet soil + container (gm)		229.60	195.70			
Weight of dry soil + container (gm)		192.70	161.00			
Weight of container (gm)		37.30	37.30			
Weight of moisture (gm)		36.90	34.70			
Weight of dry soil (gm)		155.40	123.70			
Moisture Content, % (m)		23.75	28.05			
PENETRATION DATA						
					Ring Factor (KN/DIV)	0.033153
Dry			Soaked			
Pen.(mm)	Dial Reading	Load (KN)	Pen.(mm)	Dial Reading	Load (KN)	
0.0		0.0	0.0		0.0	
0.64	192.0	6.4	0.64	15.0	0.5	
1.27	256.0	8.5	1.27	30.0	1.0	
1.91	302.0	10.0	1.91	41.0	1.4	
2.54	341.0	11.3	2.54	48.0	1.6	
3.18	376.0	12.5	3.18	54.0	1.8	
3.81	403.0	13.4	3.81	58.0	1.9	
4.45	432.0	14.3	4.45	61.0	2.0	
5.08	464.0	15.4	5.08	66.0	2.2	
7.62	529.0	17.5	7.62	81.0	2.7	
Dry CBR %			Soaked CBR %			
2.54mm	5.08mm	Corrected	2.54mm	5.08mm	Corrected	
85.4	77.1	85.4	12.0	11.0	12.0	
Swell Data						
		Initial R.	Final R.	Swell (%)		
		2.42	4.74	1.99		

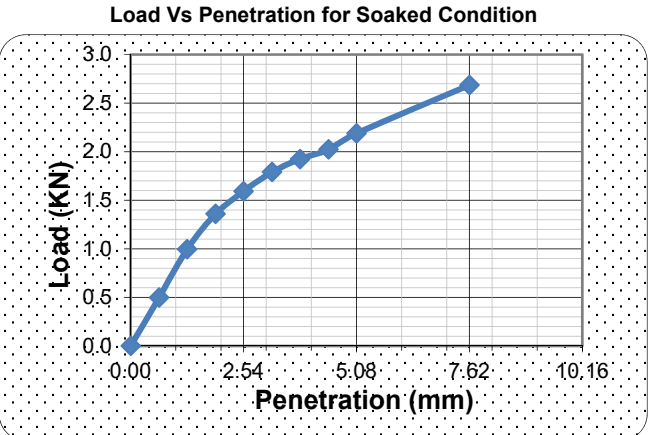
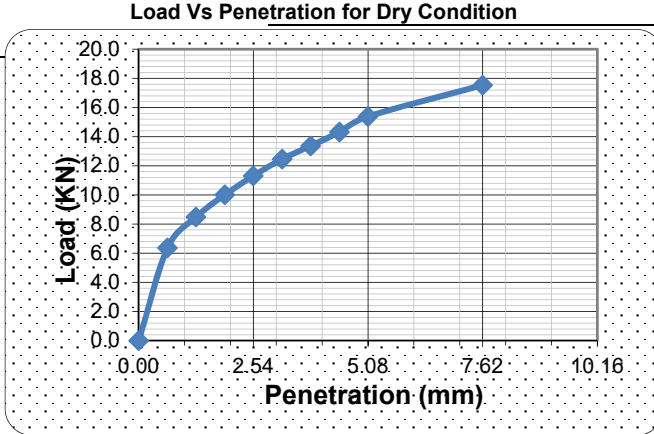

SOAKED CBR VALUE DETERMINATION FROM LABORATORY DCP TEST FOR ADDIS ABABA RED CLAY SOIL

Sample No.	:21	Dry	Soaked		
mold No		27	27		
Weight of wet soil + mold (gm)		13062	13158		
Weight of mold (gm)		8811	8811		
Weight of wet soil (gm)		4251	4347		
Volume of mold (cm ³)		2123	2123		
Wet density of soil (gm/cm ³)		2.00	2.05		
Dry density of soil (gm/cm ³)		1.63	1.63		
Moisture Content					
Can No		30	20		
Weight of wet soil + container (gm)		208.50	179.30		
Weight of dry soil + container (gm)		176.90	149.80		
Weight of container (gm)		36.60	34.80		
Weight of moisture (gm)		31.60	29.50		
Weight of dry soil (gm)		140.30	115.00		
Moisture Content, % (m)		22.52	25.65		
PENETRATION DATA					
			Ring Factor (KN/DIV)	0.033153	
Dry			Soaked		
Pen.(mm)	Dial Reading	Load (KN)	Pen.(mm)	Dial Reading	Load (KN)
0.0		0.0	0.0		0.0
0.64	73.0	2.4	0.64	19.0	0.6
1.27	136.0	4.5	1.27	35.0	1.2
1.91	190.0	6.3	1.91	55.0	1.8
2.54	240.0	8.0	2.54	70.0	2.3
3.18	290.0	9.6	3.18	84.0	2.8
3.81	320.0	10.6	3.81	90.0	3.0
4.45	340.0	11.3	4.45	96.0	3.2
5.08	360.0	11.9	5.08	102.0	3.4
7.62	390.0	12.9	7.62	116.0	3.8
Dry CBR %			Soaked CBR %		
2.54mm	5.08mm	Corrected	2.54mm	5.08mm	Corrected
60.1	59.8	60.1	17.5	16.9	17.5

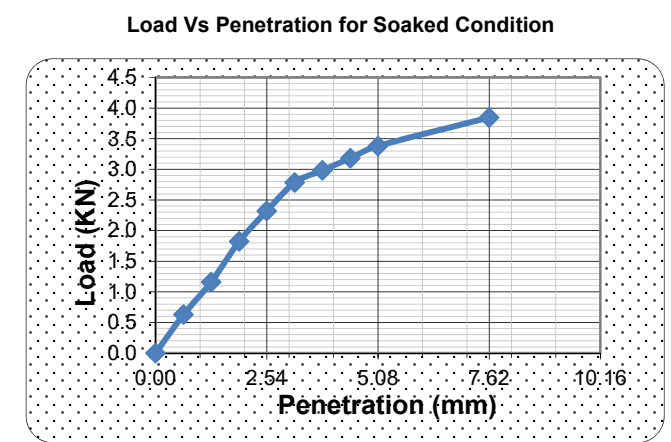
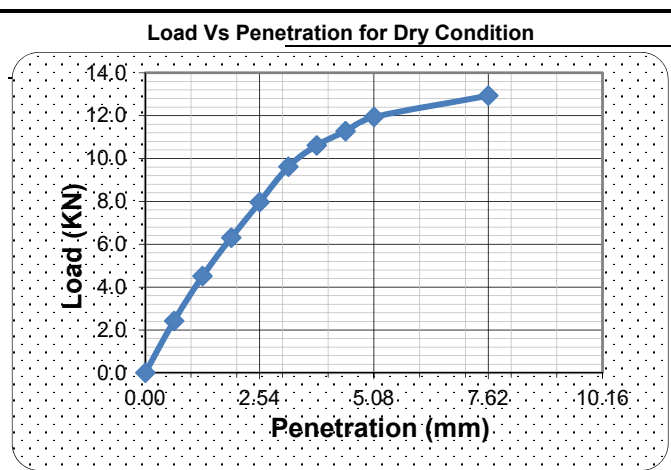

Swell Data		
Initial R.	Final R.	Swell (%)
14.84	15.05	0.18

SOAKED CBR VALUE DETERMINATION FROM LABORATORY DCP TEST FOR ADDIS ABABA RED CLAY SOIL

Sample No.	:22	Dry	Soaked
mold No		11	22
Weight of wet soil + mold (gm)		10706	10599
Weight of mold (gm)		6393	6279
Weight of wet soil (gm)		4313	4320
Volume of mold (cm ³)		2123	2123
Wet density of soil (gm/cm ³)		2.03	2.03
Dry density of soil (gm/cm ³)		1.63	1.61
Moisture Content			
Can No		23	27
Weight of wet soil + container (gm)		178.50	238.70
Weight of dry soil + container (gm)		151.30	195.90
Weight of container (gm)		40.30	35.00
Weight of moisture (gm)		27.20	42.80
Weight of dry soil (gm)		111.00	160.90
Moisture Content, % (m)		24.50	26.60

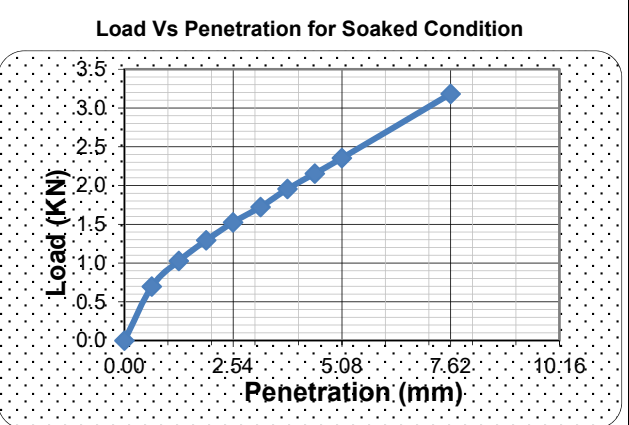
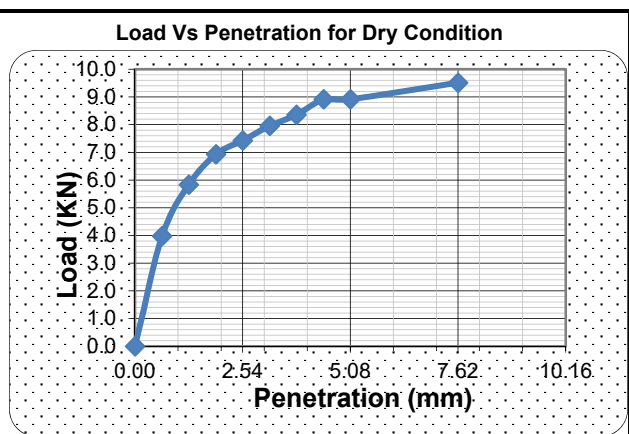

PENETRATION DATA					
			Ring Factor (KN/DIV)	0.033153	
Dry			Soaked		
Pen.(mm)	Dial Reading	Load (KN)	Pen.(mm)	Dial Reading	Load (KN)
0.0		0.0	0.0		0.0
0.64	120.0	4.0	0.64	21.0	0.7
1.27	176.0	5.8	1.27	31.0	1.0
1.91	209.0	6.9	1.91	39.0	1.3
2.54	224.0	7.4	2.54	46.0	1.5
3.18	240.0	8.0	3.18	52.0	1.7
3.81	252.0	8.4	3.81	59.0	2.0
4.45	269.0	8.9	4.45	65.0	2.2
5.08	269.0	8.9	5.08	71.0	2.4
7.62	287.0	9.5	7.62	96.0	3.2
Dry CBR %			Soaked CBR %		
2.54mm	5.08mm	Corrected	2.54mm	5.08mm	Corrected
56.1	44.7	56.1	11.5	11.8	11.8

Swell Data		
Initial R.	Final R.	Swell (%)
8.31	10.48	1.86

SOAKED CBR VALUE DETERMINATION FROM LABORATORY DCP TEST FOR ADDIS ABABA RED CLAY SOIL

Sample No.	:29	Dry	Soaked			
mold No		12	12			
Weight of wet soil + mold (gm)		12976	12696			
Weight of mold (gm)		8558	8558			
Weight of wet soil (gm)		4418	4138			
Volume of mold (cm ³)		2123	2124			
Wet density of soil (gm/cm ³)		2.08	1.95			
Dry density of soil (gm/cm ³)		1.63	1.53			
Moisture Content						
Can No		20	20			
Weight of wet soil + container (gm)		268.50	268.50			
Weight of dry soil + container (gm)		217.80	217.80			
Weight of container (gm)		34.80	34.80			
Weight of moisture (gm)		50.70	50.70			
Weight of dry soil (gm)		183.00	183.00			
Moisture Content, % (m)		27.70	27.70			
PENETRATION DATA						
					Ring Factor (KN/DIV)	0.033153
Dry			Soaked			
Pen.(mm)	Dial	Load	Pen.(mm)	Dial	Load	
	Reading	(KN)		Reading	(KN)	
0.0		0.0	0.0		0.0	
0.64	145.0	4.8	0.64	9.0	0.3	
1.27	215.0	7.1	1.27	19.0	0.6	
1.91	260.0	8.6	1.91	30.0	1.0	
2.54	305.0	10.1	2.54	43.0	1.4	
3.18	331.0	11.0	3.18	54.0	1.8	
3.81	360.0	11.9	3.81	61.0	2.0	
4.45	384.0	12.7	4.45	70.0	2.3	
5.08	405.0	13.4	5.08	75.0	2.5	
7.62	461.0	15.3	7.62	87.0	2.9	
Dry CBR %			Soaked CBR %			
2.54mm	5.08mm	Corrected	2.54mm	5.08mm	Corrected	
76.4	67.3	76.4	10.8	12.5	12.5	

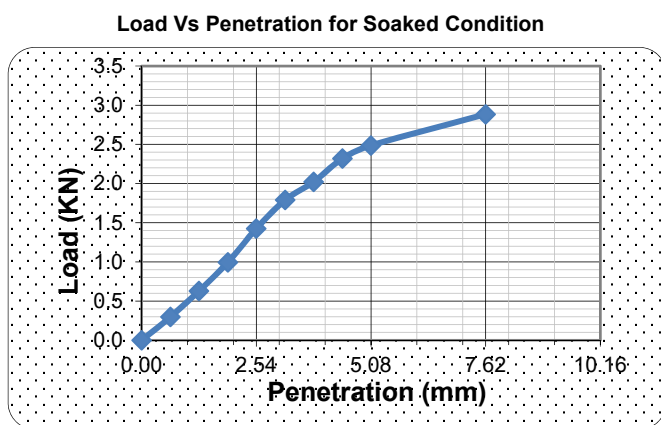
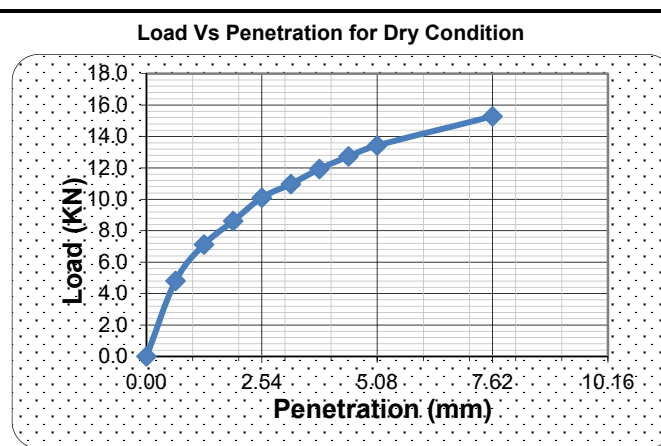

Swell Data		
Initial R.	Final R.	Swell (%)
7.68	10.69	2.59

SOAKED CBR VALUE DETERMINATION FROM LABORATORY DCP TEST FOR ADDIS ABABA RED CLAY SOIL

Sample No.	:30	Dry	Soaked		
mold No		16	16		
Weight of wet soil + mold (gm)		12776	12929		
Weight of mold (gm)		8645	8645		
Weight of wet soil (gm)		4131	4284		
Volume of mold (cm ³)		2123	2123		
Wet density of soil (gm/cm ³)		1.95	2.02		
Dry density of soil (gm/cm ³)		1.52	1.51		
Moisture Content					
Can No		W	AA		
Weight of wet soil + container (gm)		223.60	185.70		
Weight of dry soil + container (gm)		182.50	148.70		
Weight of container (gm)		37.30	38.70		
Weight of moisture (gm)		41.10	37.00		
Weight of dry soil (gm)		145.20	110.00		
Moisture Content, % (m)		28.31	33.64		
PENETRATION DATA					
			Ring Factor (KN/DIV)	0.033153	
Dry			Soaked		
Pen.(mm)	Dial	Load	Pen.(mm)	Dial	Load
	Reading	(KN)		Reading	(KN)
0.0		0.0	0.0		0.0
0.64	120.0	4.0	0.64	10.0	0.3
1.27	181.0	6.0	1.27	24.0	0.8
1.91	203.0	6.7	1.91	42.0	1.4
2.54	221.0	7.3	2.54	57.0	1.9
3.18	236.0	7.8	3.18	68.0	2.3
3.81	250.0	8.3	3.81	75.0	2.5
4.45	261.0	8.7	4.45	80.0	2.7
5.08	277.0	9.2	5.08	85.0	2.8
7.62	302.0		7.62	101.0	3.3
Dry CBR %			Soaked CBR %		
2.54mm	5.08mm	Corrected	2.54mm	5.08mm	Corrected
55.3	46.0	55.3	14.3	14.1	14.3

Load Vs Penetration for Dry Condition

Load Vs Penetration for Soaked Condition

Swell Data		
Initial R.	Final R.	Swell (%)
9.41	11.41	1.72

SOAKED CBR VALUE DETERMINATION FROM LABORATORY DCP TEST FOR ADDIS ABABA RED CLAY SOIL

Sample No.	:33	Dry	Soaked
mold No		25	25
Weight of wet soil + mold (gm)		13034	13173
Weight of mold (gm)		8699	8699
Weight of wet soil (gm)		4335	4474
Volume of mold (cm ³)		2123	2123
Wet density of soil (gm/cm ³)		2.04	2.11
Dry density of soil (gm/cm ³)		1.58	1.58
Moisture Content			
Can No		CC	K
Weight of wet soil + container (gm)		241.00	237.50
Weight of dry soil + container (gm)		195.00	187.60
Weight of container (gm)		39.80	37.90
Weight of moisture (gm)		46.00	49.90
Weight of dry soil (gm)		155.20	149.70
Moisture Content, % (m)		29.64	33.33

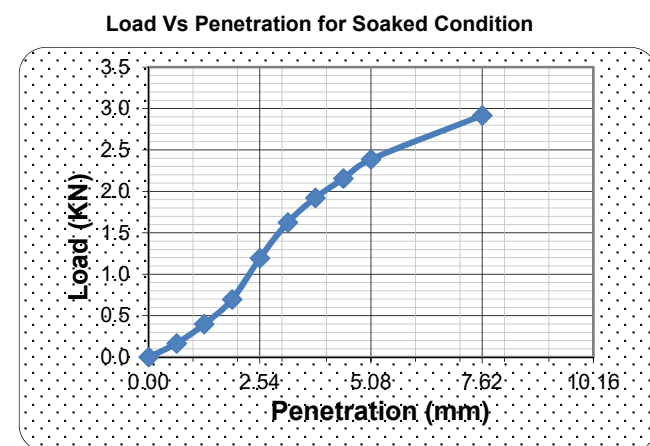
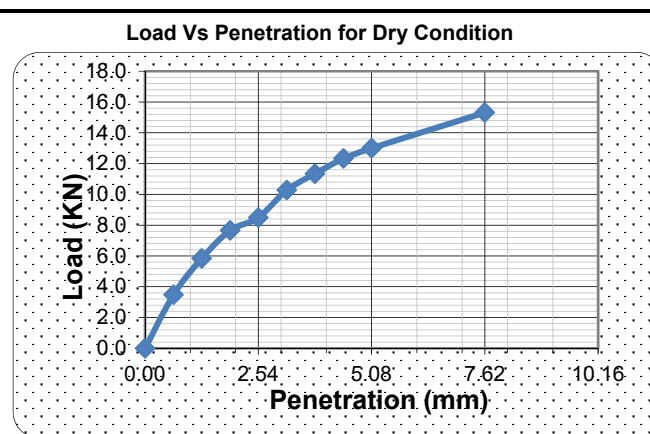

PENETRATION DATA

PENETRATION DATA					
Ring Factor (KN/DIV)					0.033153
Dry			Soaked		
Pen.(mm)	Dial Reading	Load (KN)	Pen.(mm)	Dial Reading	Load (KN)
0.0	105.0	0.0	0.0		0.0
0.64	176.0	3.5	0.64	5.0	0.2
1.27	231.0	5.8	1.27	12.0	0.4
1.91	256.0	7.7	1.91	21.0	0.7
2.54	310.0	8.5	2.54	36.0	1.2
3.18	342.0	10.3	3.18	49.0	1.6
3.81	372.0	11.3	3.81	58.0	1.9
4.45	392.0	12.3	4.45	65.0	2.2
5.08	462.0	13.0	5.08	72.0	2.4
7.62		15.3	7.62	88.0	2.9
Dry CBR %			Soaked CBR %		
2.54mm	5.08mm	Corrected	2.54mm	5.08mm	Corrected
64.1	65.1	65.1	9.0	12.0	13.0
			0.0	13.0	

Swell Data		
Initial R.	Final R.	Swell (%)
18.78	23.89	4.39

SOAKED CBR VALUE DETERMINATION FROM LABORATORY DCP TEST FOR ADDIS ABABA RED CLAY SOIL

Sample No.	:34		Dry	Soaked	
mold No			18	17	
Weight of wet soil + mold (gm)			12894	10805	
Weight of mold (gm)			8636	6369	
Weight of wet soil (gm)			4258	4436	
Volume of mold (cm ³)			2123	2123	
Wet density of soil (gm/cm ³)			2.01	2.09	
Dry density of soil (gm/cm ³)			1.58	1.57	
Moisture Content					
Can No			K	16	
Weight of wet soil + container (gm)			140.50	220.80	
Weight of dry soil + container (gm)			118.60	174.60	
Weight of container (gm)			37.90	35.90	
Weight of moisture (gm)			21.90	46.20	
Weight of dry soil (gm)			80.70	138.70	
Moisture Content, % (m)			27.14	33.31	
PENETRATION DATA					
				Ring Factor (KN/DIV)	0.033153
Dry			Soaked		
Pen.(mm)	Dial	Load	Pen.(mm)	Dial	Load
	Reading	(KN)		Reading	(KN)
0.0		0.0	0.0		0.0
0.64	66.0	2.2	0.64	10.0	0.3
1.27	160.0	5.3	1.27	21.0	0.7
1.91	230.0	7.6	1.91	32.0	1.1
2.54	260.0	8.6	2.54	42.0	1.4
3.18	288.0	9.5	3.18	50.0	1.7
3.81	309.0	10.2	3.81	55.0	1.8
4.45	330.0	10.9	4.45	60.0	2.0
5.08	346.0	11.5	5.08	65.0	2.2
7.62	400.0	13.3	7.62	79.0	2.6
Dry CBR %			Soaked CBR %		
2.54mm	5.08mm	Corrected	2.54mm	5.08mm	Corrected
65.1	57.5	65.1	10.5	10.8	10.8

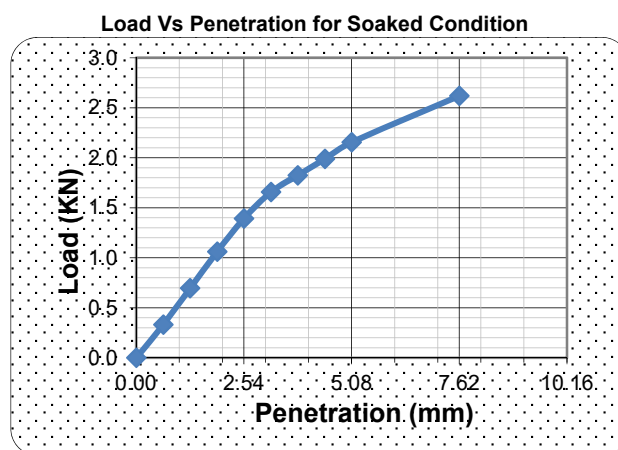
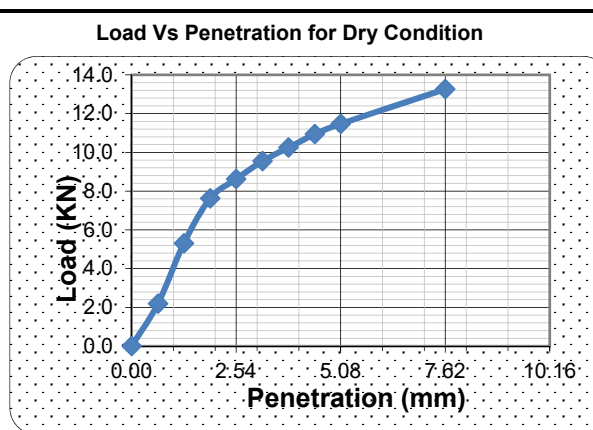

Swell Data		
Initial R.	Final R.	Swell (%)
1.84	5.52	3.16

APPENDIX G – SPSS REGRESSION ANALYSIS OUT PUTS

1. Simple linear regression analysis output (Soaked CBR with Soaked DCP)

Model Summary

Model	R	R Square	Adjusted R Square	Std. Error of the Estimate
1	.779 ^a	.607	.586	2.53715

a. Predictors: (Constant), Soaked_DCP

ANOVA^a

Model		Sum of Squares	df	Mean Square	F	Sig.
1	Regression	188.650	1	188.650	29.306	.000 ^b
	Residual	122.306	19	6.437		
	Total	310.955	20			

a. Dependent Variable: Soaked_CBR

b. Predictors: (Constant), Soaked_DCP

Coefficients^a

Model		Unstandardized Coefficients		Standardized Coefficients	t	Sig.
		B	Std. Error	Beta		
1	(Constant)	18.724	1.519		12.323	.000
	Soaked_DCP	-.351	.065	-.779	-5.414	.000

a. Dependent Variable: Soaked_CBR

2. Simple linear regression analysis output (Soaked CBR with Change in DCP)

Model Summary

Model	R	R Square	Adjusted R Square	Std. Error of the Estimate
1	.850 ^a	.722	.708	2.13223

a. Predictors: (Constant), CH_DCP

ANOVA^a

Model		Sum of Squares	df	Mean Square	F	Sig.
1	Regression	224.574	1	224.574	49.396	.000 ^b
	Residual	86.382	19	4.546		
	Total	310.955	20			

a. Dependent Variable: Soaked_CBR

b. Predictors: (Constant), CH_DCP

Coefficients^a

Model		Unstandardized Coefficients		Standardized Coefficients	t	Sig.
		B	Std. Error	Beta		
1	(Constant)	15.987	.841		19.013	.000
	CH_DCP	-.337	.048	-.850	-7.028	.000

a. Dependent Variable: Soaked_CBR

3. Simple linear regression analysis output (Soaked CBR with Change in DCP moisture content)

Model Summary

Model	R	R Square	Adjusted R Square	Std. Error of the Estimate
1	.767 ^a	.588	.566	2.59799

a. Predictors: (Constant), CH_DCP_Moist

ANOVA^a

Model		Sum of Squares	df	Mean Square	F	Sig.
1	Regression	182.714	1	182.714	27.070	.000 ^b
	Residual	128.242	19	6.750		
	Total	310.955	20			

a. Dependent Variable: Soaked_CBR

b. Predictors: (Constant), CH_DCP_Moist

Coefficients^a

Model		Unstandardized Coefficients		Standardized Coefficients	t	Sig.
		B	Std. Error	Beta		
1	(Constant)	17.164	1.302		13.180	.000
	CH_DCP_Moist	-.891	.171	-.767	-5.203	.000

a. Dependent Variable: Soaked_CBR

4. Simple linear regression analysis output (Soaked CBR with OMC)

Model Summary

Model	R	R Square	Adjusted R Square	Std. Error of the Estimate
1	.159 ^a	.025	-.026	3.99378

a. Predictors: (Constant), OMC

ANOVA^a

Model		Sum of Squares	df	Mean Square	F	Sig.
1	Regression	7.900	1	7.900	.495	.490 ^b
	Residual	303.055	19	15.950		
	Total	310.955	20			

a. Dependent Variable: Soaked_CBR

b. Predictors: (Constant), OMC

Coefficients^a

Model		Unstandardized Coefficients		Standardized Coefficients	t	Sig.
		B	Std. Error	Beta		
1	(Constant)	4.833	8.898		.543	.593
	OMC	.256	.364	.159	.704	.490

a. Dependent Variable: Soaked_CBR

5. Simple linear regression analysis output (Soaked CBR with MDD)

Model Summary

Model	R	R Square	Adjusted R Square	Std. Error of the Estimate
1	.547 ^a	.299	.262	3.38668

a. Predictors: (Constant), MDD

ANOVA^a

Model		Sum of Squares	df	Mean Square	F	Sig.
1	Regression	93.033	1	93.033	8.111	.010 ^b
	Residual	217.922	19	11.470		
	Total	310.955	20			

a. Dependent Variable: Soaked_CBR

b. Predictors: (Constant), MDD

Coefficients^a

Model		Unstandardized Coefficients		Standardized Coefficients	t	Sig.
		B	Std. Error	Beta		
1	(Constant)	-59.209	24.685		-2.399	.027
	MDD	44.814	15.735	.547	2.848	.010

a. Dependent Variable: Soaked_CBR

6. Simple linear regression analysis output (Soaked CBR with PI)

Model Summary

Model	R	R Square	Adjusted R Square	Std. Error of the Estimate
1	.318 ^a	.101	.054	3.83608

a. Predictors: (Constant), PI

ANOVA^a

Model	Sum of Squares	df	Mean Square	F	Sig.
1 Regression	31.361	1	31.361	2.131	.161 ^b
1 Residual	279.595	19	14.716		
Total	310.955	20			

a. Dependent Variable: Soaked_CBR

b. Predictors: (Constant), PI

Coefficients^a

Model		Unstandardized Coefficients		Standardized Coefficients	t	Sig.
		B	Std. Error	Beta		
1	(Constant)	18.459	5.134		3.595	.002
	PI	-.303	.208	-.318	-1.460	.161

a. Dependent Variable: Soaked_CBR



7. Simple linear regression analysis output (Soaked DCP with Un-soaked_DCP)

Model Summary

Model	R	R Square	Adjusted R Square	Std. Error of the Estimate
1	.238 ^a	.057	.007	8.71418

a. Predictors: (Constant), Unsoaked_DCP

ANOVA^a

Model		Sum of Squares	df	Mean Square	F	Sig.
1	Regression	86.435	1	86.435	1.138	.299 ^b
	Residual	1442.803	19	75.937		
	Total	1529.238	20			

a. Dependent Variable: Soaked_DCP

b. Predictors: (Constant), Unsoaked_DCP

Coefficients^a

Model		Unstandardized Coefficients		Standardized Coefficients	t	Sig.
		B	Std. Error	Beta		
1	(Constant)	26.619	4.892		5.441	.000
	Unsoaked_DCP	-.669	.627	-.238	-1.067	.299

a. Dependent Variable: Soaked_DCP

8. Simple linear regression analysis output (Soaked DCP with Change in DCP)

Model Summary

Model	R	R Square	Adjusted R Square	Std. Error of the Estimate
1	.953 ^a	.908	.903	2.72167

a. Predictors: (Constant), CH_DCP

ANOVA^a

Model		Sum of Squares	df	Mean Square	F	Sig.
1	Regression	1388.495	1	1388.495	187.444	.000 ^b
	Residual	140.743	19	7.408		
	Total	1529.238	20			

a. Dependent Variable: Soaked_DCP

b. Predictors: (Constant), CH_DCP

Coefficients^a

Model		Unstandardized Coefficients		Standardized Coefficients	t	Sig.
		B	Std. Error	Beta		
1	(Constant)	9.570	1.073		8.917	.000
	CH_DCP	.837	.061	.953	13.691	.000

a. Dependent Variable: Soaked_DCP

9. Simple linear regression analysis output (Soaked DCP with Change in DCP moisture)

Model Summary

Model	R	R Square	Adjusted R Square	Std. Error of the Estimate
1	.639 ^a	.408	.377	6.90119

a. Predictors: (Constant), CH_DCP_Moist

Coefficients^a

Model		Unstandardized Coefficients		Standardized Coefficients	t	Sig.
		B	Std. Error	Beta		
1	(Constant)	10.533	3.459		3.045	.007
	CH_DCP_Moist	1.647	.455	.639	3.621	.002

a. Dependent Variable: Soaked_DCP

ANOVA^a

Model		Sum of Squares	df	Mean Square	F	Sig.
1	Regression	624.335	1	624.335	13.109	.002 ^b
	Residual	904.903	19	47.626		
	Total	1529.238	20			

a. Dependent Variable: Soaked_DCP

b. Predictors: (Constant), CH_DCP_Moist

10. Multiple linear regression analysis output (Soaked CBR with Soaked DCP and Change in DCP)

Model Summary

Model	R	R Square	Adjusted R Square	Std. Error of the Estimate
1	.856 ^a	.733	.703	2.14941

a. Predictors: (Constant), CH_DCP, Soaked_DCP

ANOVA^a

Model		Sum of Squares	df	Mean Square	F	Sig.
1	Regression	227.796	2	113.898	24.653	.000 ^b
	Residual	83.159	18	4.620		
	Total	310.955	20			

a. Dependent Variable: Soaked_CBR

b. Predictors: (Constant), CH_DCP, Soaked_DCP

Coefficients^a

Model		Unstandardized Coefficients		Standardized Coefficients	t	Sig.
		B	Std. Error	Beta		
1	(Constant)	14.538	1.930		7.533	.000
	Soaked_DCP	.151	.181	.336	.835	.415
	CH_DCP	-.463	.159	-1.170	-2.911	.009

a. Dependent Variable: Soaked_CBR

11. Multiple linear regression analysis output (Soaked CBR with Soaked DCP and Change in DCP moisture)

Model Summary

Model	R	R Square	Adjusted R Square	Std. Error of the Estimate
1	.854 ^a	.729	.699	2.16434

a. Predictors: (Constant), CH_DCP_Moist, Soaked_DCP

ANOVA^a

Model		Sum of Squares	df	Mean Square	F	Sig.
1	Regression	226.636	2	113.318	24.191	.000 ^b
	Residual	84.319	18	4.684		
	Total	310.955	20			

a. Dependent Variable: Soaked_CBR

b. Predictors: (Constant), CH_DCP_Moist, Soaked_DCP

Coefficients^a

Model		Unstandardized Coefficients		Standardized Coefficients	t	Sig.
		B	Std. Error	Beta		
1	(Constant)	19.485	1.323		14.723	.000
	Soaked_DCP	-.220	.072	-.489	-3.062	.007
	CH_DCP_Moist	-.528	.185	-.454	-2.848	.011

a. Dependent Variable: Soaked_CBR

12. Simple logarithmic regression analysis output (Soaked CBR with soaked DCP)

Model Summary

Model	R	R Square	Adjusted R Square	Std. Error of the Estimate
1	.815 ^a	.664	.646	.10415

a. Predictors: (Constant), Log_Soaked_DCP

Coefficients^a

Model		Unstandardized Coefficients		Standardized Coefficients	t	Sig.
		B	Std. Error	Beta		
1	(Constant)	2.159	.188		11.461	.000
	Log_Soaked_DCP	-.875	.143	-.815	-6.126	.000

a. Dependent Variable: Log_Soaked_CBR

ANOVA^a

Model		Sum of Squares	df	Mean Square	F	Sig.
1	Regression	.407	1	.407	37.529	.000 ^b
	Residual	.206	19	.011		
	Total	.613	20			

a. Dependent Variable: Log_Soaked_CBR

b. Predictors: (Constant), Log_Soaked_DCP

13. Simple logarithmic regression analysis output (Soaked CBR with Change in DCP)

Model Summary

Model	R	R Square	Adjusted R Square	Std. Error of the Estimate
1	.793 ^a	.629	.610	.10942

a. Predictors: (Constant), Log_CH_DCP

ANOVA^a

Model		Sum of Squares	df	Mean Square	F	Sig.
1	Regression	.386	1	.386	32.218	.000 ^b
	Residual	.227	19	.012		
	Total	.613	20			

a. Dependent Variable: Log_Soaked_CBR

b. Predictors: (Constant), Log_CH_DCP

Coefficients^a

Model		Unstandardized Coefficients		Standardized Coefficients	t	Sig.
		B	Std. Error	Beta		
1	(Constant)	1.455	.081		17.863	.000
	Log_CH_DCP	-.418	.074	-.793	-5.676	.000

a. Dependent Variable: Log_Soaked_CBR

14. Simple logarithmic regression analysis output (Soaked CBR with Change in DCP moisture)

Model Summary

Model	R	R Square	Adjusted R Square	Std. Error of the Estimate
1	.709 ^a	.503	.477	.12660

a. Predictors: (Constant), Log_CH_DCP_moist

ANOVA^a

Model		Sum of Squares	df	Mean Square	F	Sig.
1	Regression	.309	1	.309	19.258	.000 ^b
	Residual	.305	19	.016		
	Total	.613	20			

a. Dependent Variable: Log_Soaked_CBR

b. Predictors: (Constant), Log_CH_DCP_moist

Coefficients^a

Model		Unstandardized Coefficients		Standardized Coefficients	t	Sig.
		B	Std. Error	Beta		
1	(Constant)	1.367	.085		16.044	.000
	Log_CH_DCP_moist	-.460	.105	-.709	-4.388	.000

a. Dependent Variable: Log_Soaked_CBR

15. Simple logarithmic regression analysis output (Soaked DCP with Change in DCP)

Model Summary

Model	R	R Square	Adjusted R Square	Std. Error of the Estimate
1	.852 ^a	.725	.711	.08766

a. Predictors: (Constant), Log_CH_DCP

ANOVA^a

Model		Sum of Squares	df	Mean Square	F	Sig.
1	Regression	.385	1	.385	50.146	.000 ^b
	Residual	.146	19	.008		
	Total	.531	20			

a. Dependent Variable: Log_Soaked_DCP

b. Predictors: (Constant), Log_CH_DCP

Coefficients^a

Model		Unstandardized Coefficients		Standardized Coefficients	t	Sig.
		B	Std. Error	Beta		
1	(Constant)	.867	.065		13.277	.000
	Log_CH_DCP	.418	.059	.852	7.081	.000

a. Dependent Variable: Log_Soaked_DCP

16. Simple logarithmic regression analysis output (Soaked DCP with Change in DCP moisture)

Model Summary

Model	R	R Square	Adjusted R Square	Std. Error of the Estimate
1	.635 ^a	.404	.372	.12912

a. Predictors: (Constant), Log_CH_DCP_moist

ANOVA^a

Model		Sum of Squares	df	Mean Square	F	Sig.
1	Regression	.215	1	.215	12.868	.002 ^b
	Residual	.317	19	.017		
	Total	.531	20			

a. Dependent Variable: Log_Soaked_DCP

b. Predictors: (Constant), Log_CH_DCP_moist

Coefficients^a

Model		Unstandardized Coefficients		Standardized Coefficients	t	Sig.
		B	Std. Error	Beta		
1	(Constant)	1.014	.087		11.665	.000
	Log_CH_DCP_moist	.383	.107	.635	3.587	.002

a. Dependent Variable: Log_Soaked_DCP

17. Multiple logarithmic regression analysis output (Soaked CBR with Soaked DCP and Change in DCP)

Model Summary

Model	R	R Square	Adjusted R Square	Std. Error of the Estimate
1	.837 ^a	.700	.666	.10114

a. Predictors: (Constant), Log_CH_DCP, Log_Soaked_DCP

ANOVA^a

Model		Sum of Squares	df	Mean Square	F	Sig.
1	Regression	.429	2	.215	20.973	.000 ^b
	Residual	.184	18	.010		
	Total	.613	20			

a. Dependent Variable: Log_Soaked_CBR

b. Predictors: (Constant), Log_CH_DCP, Log_Soaked_DCP

Coefficients^a

Model		Unstandardized Coefficients		Standardized Coefficients	t	Sig.
		B	Std. Error	Beta		
1	(Constant)	1.928	.241		7.984	.000
	Log_Soaked_DCP	-.545	.265	-.507	-2.059	.054
	Log_CH_DCP	-.190	.130	-.361	-1.466	.160

a. Dependent Variable: Log_Soaked_CBR

18. Multiple logarithmic regression analysis output (Soaked CBR with Soaked DCP and Change in DCP moisture)

Model Summary

Model	R	R Square	Adjusted R Square	Std. Error of the Estimate
1	.852 ^a	.726	.695	.09670

a. Predictors: (Constant), Log_CH_DCP_moist, Log_Soaked_DCP

ANOVA^a

Model	Sum of Squares	df	Mean Square	F	Sig.
1 Regression	.445	2	.222	23.793	.000 ^b
Residual	.168	18	.009		
Total	.613	20			

a. Dependent Variable: Log_Soaked_CBR

b. Predictors: (Constant), Log_CH_DCP_moist, Log_Soaked_DCP

Coefficients^a

Model	Unstandardized Coefficients		Standardized Coefficients	t	Sig.
	B	Std. Error	Beta		
1 (Constant)	2.032	.186		10.929	.000
Log_Soaked_DCP	-.656	.172	-.610	-3.817	.001
Log_CH_DCP_moist	-.208	.104	-.322	-2.011	.060

a. Dependent Variable: Log_Soaked_CBR

DECLARATION

I, the undersigned, declare that this thesis is my original work performed under the supervision of my research advisor Dr. Ing Samuel Tadesse and has not been presented as a thesis for a degree in any other university. All sources of materials used for this thesis have also been duly acknowledged.

Name: Ashenafi Mulugeta Regassa

Signature: _____

Place: Addis Ababa University, Institute of Technology

School of Graduate Studies, Addis Ababa Institute of Technology

Department of Civil Engineering,

Addis Ababa.

Date: June 2016