

APPLICATION OF MODERN FORMWORK SYSTEMS IN ETHIOPIA

**BY
ARGAW TAREKEGN**

**ADVISORS: Prof. Dr. -Ing. Abebe Dinku
Prof. Dr. -Ing. Christoph Motzko**



A thesis submitted to the School of Graduate Studies of
Addis Ababa University in partial fulfillment of the requirements for
the Degree of Master of Science in Civil Engineering
(Construction Technology and Management)



ADDIS ABABA UNIVERSITY
SCHOOL OF GRADUATE STUDIES

FACULTY OF TECHNOLOGY
DEPARTMENT OF CIVIL ENGINEERING

APPLICATION OF MODERN FORMWORK SYSTEMS IN ETHIOPIA

By

Argaw Tarekegn

Approved by Board of Examiners

Prof.Dr-Ing Abebe Dinku
Advisor

Signature

Date

Dr.Ing Woubishet Jekale
Internal Examiner

Signature

Date

Eng. Yibeltal Zewdu
External Examiner

Signature

Date

Eng.Nasir Bedwi
Chairman

Signature

Date

ACKNOWLEDGEMENTS

First and foremost, I would like to express my sincere gratitude to my advisor Prof. Dr.-Ing. Abebe Dinku, for his patience, motivation, enthusiasm, and immense knowledge. His guidance and support both during lectures and research is very crucial for me in mastering the subject.

I owe my deepest gratitude to Professor Dr.-Ing. Christoph Motzko for his valuable comments, encouragements and also for providing me with working space and other facilities to conduct part of my thesis carried out at the Technical University of Darmstadt, Germany.

I would also like to use this opportunity to convey my gratitude to DAAD for offering me short term scholarship to stay and conduct part of my research in Germany at the Technical University of Darmstadt.

I am indebted to many of my colleagues who supported me in distributing and collecting research questionnaires. It is also my pleasure to thank those who made this thesis possible by responding to questionnaires and interviews.

Finally, I would like to thank my family members for their unconditional support, encouragement and love.

Argaw Tarekegn

Addis Ababa, November 2010

TABLE OF CONTENTS

ACKNOWLEDGEMENTS	II
TABLE OF CONTENTS	III
LIST OF TABLES	VI
LIST OF FIGURES	VI
ABSTRACT	VIII
CHAPTER ONE	
INTRODUCTION	1
1.1 Background	1
1.2 Objectives of the Research	2
1.3 Scope and limitation of the Study	3
1.4 Significance of the Study	3
1.5 Research Methodology	4
1.5.1 Study Strategy	4
1.5.2 Research Instruments	4
1.5.3 Data and Information Sources	5
1.5.4 Data Collection and Analysis	5
CHAPTER TWO	
LITERATURE REVIEW	6
2.1 Definition of Formwork	6
2.2 Requirements for Formworks	6
2.2.1 Economy	7
2.2.2 Speed	9
2.2.3 Quality	10
2.2.3a Strength	10
2.2.3b Stiffness, Accuracy and Water Tightness	10
2.2.4 Safety and Health	11
2.2.4a Causes of Formwork Failure	13
2.3 Ethiopian Formwork Construction Systems	15
2.3.1 Introduction	15
2.3.2 Footing Pad and Foundation Column Construction Systems	15
2.3.3 Slab and Beam Formwork Construction Systems	17
2.3.4 Advantages and Disadvantages of Traditional Formwork Systems	18
2.4 Classification of Formworks	19
2.4.1 Classification According to Size	20
2.4.2 Classification According to Location of Use	20
2.4.3 Classification According to Nature of Operation	20
2.4.4 Classification According to Brand Name of the Product	20
2.4.4a MIVAN Formwork Systems	21
2.4.4b PERI Formwork Systems	21
2.4.4c Doka Formwork Systems	22
2.4.4d Other International Formwork Systems	22
2.4.5 Classification According to Materials of Formwork	22
2.4.5a Steel Formwork	23

2.4.5b Aluminum Formwork.....	24
2.4.5c Glass-Reinforced Plastic.....	25
2.4.5d Concrete as Formwork	25
2.4.5e Stremaform Formwork	26
2.4.5f Cardboard Formwork.....	27
2.4.5g Plastic Formwork	28
2.4.5h Timber Formwork.....	29
2.4.5i Plywood Formwork	31
2.4.5j Wood particleboard and Hardboard.....	32
2.4.5k Insulated Concrete Formworks	33
2.4.5l Permeable Formwork.....	35
2.4.5m Permanent Formworks	36
2.5 Special Formwork Systems.....	37
2.5.1 Flying Formwork Systems	37
2.5.2 Tunnel Formwork System.....	38
2.5.3 Ganged Formworks.....	39
2.5.4 Jump Formworks	40
2.5.5 Slip Formworks	40
2.6 Formwork Hardware.....	41
2.6.1 Form Ties	41
2.6.2 Form Anchors.....	42
2.7 Form Release Agents.....	43
2.8 Stripping of Formwork	45
2.8.1 ACI Recommendation.....	45
2.8.2 British Standards Recommendations	46
2.8.3 German Recommendations	48
2.8.4 Ethiopian Standards Recommendations.....	48
2.8.5 Comparison of Recommendations for Formwork Stripping Times.....	49
2.9 Selection of Formworks.....	49
2.9.1 Building Design and Shape	49
2.9.2 Job Specification.....	50
2.9.3 Local Conditions.....	51
2.9.3a Area Practice.....	51
2.9.3b Site Characteristics.....	51
2.9.4 Supporting Organization	51
2.9.4a Available Capital.....	52
2.9.4b Supporting Yard Facility	53
CHAPTER THREE	
CASE STUDY.....	54
3.1 Introduction	54
3.2 Formwork Girders	55
3.2.1 GT 24	56
3.2.2 VT 20k	57
3.3 Wall Formworks.....	58
3.3.1 MAXIMO Panel	58
3.3.2 TRIO Panel.....	60

3.3.3 DOMINO Panel.....	61
3.3.4 RUNDIFLEX Circular Formwork.....	62
3.3.5 HANDSET Formwork.....	63
3.3.6 VARIO GT24 Girder Formwork.....	64
3.4 Column Formwork.....	65
3.4.1 RAPID Formwork.....	65
3.4.2 QUATTRO Formwork.....	66
3.4.3 SRS Steel Circular Formwork.....	67
3.5 Slab Formworks.....	69
3.5.1 SKYDECK Aluminum Formwork.....	69
3.5.2 GRID FLEX Aluminum Formwork.....	70
3.5.3 MULTIFLEX Girder Formwork.....	71
3.5.4 PERI Slab Tables.....	72
3.6 Beam Formwork.....	74
3.6.1 UZ Beam Formwork.....	74
3.7 Climbing Systems.....	75
3.7.1 CB Climbing Systems.....	75
3.7.2 RCS Rail Climbing Systems.....	76
3.7.3 ACS Self Climbing System.....	78
3.8 Plywood Form Lining and System Independent Accessories.....	79
3.8.1 Plywood.....	79
3.8.2 Peridrain Fabric.....	81
3.8.3 PERI BIO Clean.....	82
CHAPTER FOUR	
ANALYSIS AND DISCUSSION.....	83
4.1 General.....	83
4.2 Formwork Materials and Costs in Addis Ababa.....	84
4.3 Formwork Construction Practices in Ethiopia.....	88
4.4 Safety and Environment Issues in Formwork Construction.....	95
4.5 Suitable Wall Formwork System for Ethiopia.....	100
4.6 Suitable Slab Formwork System for Ethiopia.....	104
4.7 Suitable Column and Beam Formwork Systems for Ethiopia.....	106
4.8 Special Formworks for Developing Country.....	108
4.9 Transportation of Formwork on Site.....	109
4.10 Rental Formwork.....	110
4.10.1 Price Structure for Rental Formwork.....	110
4.10.1a Formwork Material Rental Charges.....	110
4.10.1b Non-recurring (One-Off) Costs.....	111
4.10.1c Additional (special) Services.....	111
CHAPTER FIVE	
CONCLUSION AND RECOMMENDATIONS.....	113
5.1 Conclusion.....	113
5.2 Recommendations.....	115
BIBLIOGRAPHY.....	117
APPENDIX ONE.....	121
QUESTIONNAIRES.....	121

LIST OF TABLES

Table 2.1 ACI General Guidelines for Form Stripping Times	46
Table 2.2 Minimum Period before Striking Formwork as Per BS.....	47
Table 2.3 Guideline for Formwork Stripping Times as per German Standards.....	48
Table 2.4 EBCS 2 Recommendation for Formwork Stripping Times	48
Table 2.5 Effect of Concrete Formwork Cost Based on one use equal to 1.00.....	52
Table 3.1 Comparison of VT 20K and GT 24	58
Table 4.1 Questionnaires Response Rate.....	84
Table 4.2 Productivity of Formwork Construction in Addis Ababa.....	90
Table 4.3 Test Results of Concrete Cubes Casted with PPC	93
Table 4.4 Test Results of Concrete Cubes Casted with OPC	94
Table 4.5 Recommended times for shuttering and stripping of wall formworks.....	102
Table 4.6 Material Costs of PERI products.....	105
Table 4.7 Weight of PERI formwork elements without accessories	109

LIST OF FIGURES

Figure 1.1 Flow chart of Research Methodology.....	4
Figure 2.1 Distribution of costs for cast-in-place concrete (a) slab, (b) wall	7
Figure 2.2 Formwork Life Cycle	9
Figure 2.3 lateral Pressure Distributions of Concrete	14
Figure 2.4 Footing pad formwork construction system in Addis Ababa.....	16
Figure 2.5 Column formwork construction systems in Addis Ababa.	16
Figure 2.6 Slab formwork construction systems in Addis Ababa.....	17
Figure 2.7 Beam Formwork Construction Systems in Addis Ababa.	18
Figure 2.8 Concrete as formwork material	26
Figure 2.9 Stremaform	27
Figure 2.10 Cardboard formwork	28
Figure 2.11 Geoplast Plastic formworks	29
Figure 2.8 Embodied energy in building materials	30
Figure 2.12 Embodied energy in building materials	30
Figure 2.13 Plywood orientation	31
Figure 2.14 Manufacture and Standard Types of Wood Particleboard	32
Figure 2.15 ICF Block System	34
Figure 2.16 Separate planks tied together and a range of tie sizes.....	34
Figure 2.17 Action of Permeable Formwork	35
Figure 2.18 Through Tie System	42
Figure 2.19 Typical lost tie assembly.....	42
Figure 2.20 Uni -Sleeve anchor System	43
Figure 3.1 GT 24 Girder.....	56
Figure 3.2 Girder extension	57
Figure 3.3 VT 20K Girder	57
Figure 3.4 PERI MAXIMO Panel.....	59

Figure 3.5 Uniform arrangements of MAXIMO tie points	59
Figure 3.6 TRIO panel.....	60
Figure 3.7 Alignment coupler.....	60
Figure 3.8 DOMINO panel as foundation shuttering.....	62
Figure 3.9 Adjustment of RUNDIFLEX	63
Figure 3.10 HANDSET wall formwork and its clip	63
Figure 3.11 PERI VARIO wall formwork.....	64
Figure 3.12 PERI RAPID clamping principle	65
Figure 3.13 RAPID column formwork with ladder and concreting platform.....	66
Figure 3.14 Complete PERI QUATTRO unit with its eye bolts.....	67
Figure 3.15 the four elements of PERI SRS	68
Figure 3.16 Lifting eyes and stacking aids on the column elements.....	68
Figure 3.17 large prop spacing (left).....	69
Figure 3.18 Erection of GRIDIFLEX.....	70
Figure 3.19 PERI MULTIFLEX.....	72
Figure 3.20 PERI Table Module VT	73
Figure 3.21 PERI SKYTABLE.....	74
Figure 3.22 UZ beam formwork with its bracket and perforated rail.....	75
Figure 3.23 CB Climbing System	76
Figure 3.24 RCS shuttering and protection panels.....	77
Figure 3.25 RCS Climbing rail: 4° forward angle position	78
Figure 3.26 PERI ACS climbing Mechanism.....	79
Figure 3.27 Fin-ply	79
Figure 3.28 FinNa-ply	80
Figure 3.29 Peridrian Fabric	81
Figure 4.1 Formwork Materials Used by Contractors in Ethiopia.....	84
Figure 4.2 Sources of Local Formworks	86
Figure 4.3 Distribution of costs for cast-in-place concrete for slab construction in Addis Ababa	87
Figure 4.4 Transportation of Formworks in Addis Ababa.....	89
Figure 4.5 Formwork stripping times in Addis Ababa.....	91
Figure 4.6 Safe Material Handling and Transportation.....	96
Figure 4.7 Safety Guard Rails and Platform, Darmstadt.....	96
Figure 4.8 Formwork Release Agents Used in Addis Ababa	97
Figure 4.9 Concrete surface casted using TRIO panel, Darmstadt	101
Figure 4.10 Concrete column formwork casted using PERI formwork, Darmstadt	107
Figure 4.11 Self Climbing Systems at Tower 185, Frankfurt.....	108

ABSTRACT

The quality of resulting concrete can be dictated by the quality of formwork materials and workmanship. Many concrete related problems such as discoloration, stains, and dusting are attributed to concrete formwork. Formwork operations are also risky and workers are exposed to unsafe working conditions. Moreover traditional formwork construction has negative impact on the environment. The objectives of this research are to assess the current practices of formwork construction in Ethiopia and identify problems such as loss of productivity, delay of projects, safety problems and environmental effects. Recommendations of modern formwork systems which alleviate such problems are also the objective of this thesis.

The study was conducted by taking formwork systems of the famous formwork producing and renting company, PERI Germany, as the case study. Almost all the products of the company were studied through desk study. Questionnaires and interviews were conducted among contractors in Addis Ababa to get relevant data which helps to achieve the objectives of this thesis. Formwork rental companies and regulatory bodies in Addis Ababa were also interviewed.

The results of the research show that alternative formwork materials are not well known and used in Ethiopian construction industry. Steel panels and timber are the prominent formwork materials. The use of modern formwork systems will increase the local labor productivity to ten times the traditional one. About 60% of the total time will be saved if new construction systems are adopted by construction firms in Ethiopia. Formwork construction practice in Ethiopia is not safe and environmentally friendly. Seventy nine percent of the respondents have recent record of injury and death which emanates from formwork construction. Finally, modern formworks such as MULTIFLEX, TRIO, QUATTRO and UZ are assessed and recommended for major construction projects in Ethiopia.

CHAPTER ONE

INTRODUCTION

1.1 Background

Forms are extremely important in concrete construction. They mold the concrete to the required size and shape while controlling its position and alignment. They are self-supporting structures that are also sufficient to hold the dead load of the reinforcement and fresh concrete and the live load of equipment, workers, and miscellaneous materials.

In building and designing formwork, three major objectives must be considered:

1. *Quality*—Forms must be designed and built with sufficient stiffness and accuracy so the size, shape, position, and finish of the cast concrete are attained within the required tolerances.
2. *Safety*—Forms must be built with sufficient strength and factors of safety so they are capable of supporting all dead and live loads without collapse or danger to workers and to the concrete structure.
3. *Economy*—Forms must be built efficiently, minimizing time and cost in the construction process and schedule for the benefit of both the contractor and the owner [30].

Formwork is the largest cost component for a reinforced concrete structures. Its cost accounts for 40 to 60 percent of the cost of the concrete frame in developed country. A large proportion of the cost of conventional formwork is related to formwork labor costs. Significant cost saving could be achieved by reducing labor costs. Formwork costs can also be reduced by carefully considering the materials and equipment to be used; the fabrication, erection, and stripping procedures; and the reuse of forms [11].

Speed, safety and quality are also other important aspects in the formwork operation. Faster formwork cycle from erection to stripping would allow for faster removal of shoring and reshoring and faster overall project progress.

Formwork operations are also risky, and workers are typically exposed to unsafe working conditions. Partial or total failure of concrete formwork is a major contributor to deaths, injuries, and property damages within the construction industry. Another common hazard occurs during stripping of formwork in which loose formwork elements fall on workers under the concrete slab being stripped.

The quality of the resulting concrete is affected by the quality of formwork materials and workmanship. Many concrete-related problems such as discoloration, stains, and dusting are attributed to concrete formwork. Also, some deformed concrete surfaces are due to deformed formwork systems caused by repetitive reuse and inadequate support of formwork [11].

Conventional formwork construction system in Ethiopia takes relatively longer time to strip and erect. The labor time for production and erecting of formworks is relatively longer. This will also add costs to the project as the contractor's productivity will be reduced. The quality of concrete surfaces is mostly not good as proper formworks are not designed and constructed accordingly. The concrete surfaces are either chiseled or additional plastering is applied to rectify the poor appearance. Hence, the use of modern formworks which solves the above problems in Ethiopia is very mandatory to have better concrete fulfilling the requirements. Therefore, this is to study and recommend suitable modern formwork systems which will alleviate the major problems of traditional formwork construction in Ethiopia.

1.2 Objectives of the Research

The main objective of this thesis is to introduce modern formwork systems which fulfill the quality, safety, environment and economic requirements to the construction industry of Ethiopia. The specific objectives are:

- To investigate the materials of the formwork and methods used in erecting the modern formwork systems in developed country.

- To recommend the best formwork system that fulfills the cost, quality and safety requirements to the Ethiopian construction industry.
- To identify the threat that the use of local traditional formwork systems has on the environment.
- To investigate the delay of the local construction practices in not using modern formwork systems.
- To propose the mechanism of reducing cost by using modern formwork systems in local construction practices.
- To identify the current costs of local forms and analyze the percentage of the labor and material costs of formworks for cast in situ concrete.

1.3 Scope and limitation of the Study

The research focuses on the formwork systems for building projects. Formworks for precast concrete elements are out of the scope of this thesis. Only cast in situ concrete formworks are investigated. Different types of Wall, column, beam, slab and special formwork systems such as self-climbing are investigated.

1.4 Significance of the Study

The research is believed to initiate the local contractors in using standard formwork systems. Local professionals can appreciate the modern formwork systems in this thesis and be motivated to design and construct safe and economical formwork systems. The environmental effects of construction of formwork are also revealed through this research. Regulatory body such as Ministry of Works and Urban Development will be benefited in modifying the regulation of licensing of contractors or introducing methods of use of formworks for high rise buildings.

1.5 Research Methodology

The methods of research which is applied to achieve the objectives of this research are described in the following sub sections.

1.5.1 Study Strategy

The study is carried out in four major phases, following the identification of the problem from observation of local construction projects. At first phase, detailed literature review on formworks was conducted. Formworks were investigated from different point of view such as material, construction methods, safety, health and environment. During Second phase, data were collected through questionnaires, interview and desk study. The third phase of the study was analyzing the collected data and discussion on the results obtained. The last phase was to draw conclusions and forward recommendations to improve the current practice of formwork construction systems in Ethiopia (see fig 1.1).



Figure 1.1 Flow chart of Research Methodology

1.5.2 Research Instruments

Questionnaires, interview and desk study were the three major instruments used in this thesis. Questionnaires were distributed to randomly selected contractors whose grade ranges from one to six. Interview was conducted among stakeholders of formwork construction such as formwork renting individuals and regulatory bodies. Case company was selected based on its adaptability to developing country in terms of methods of construction, availability of materials and versatility of its sizes. After conducting literature review on various international formwork products, PERI Germany's formworks were selected for further study and the result will be presented in chapter three.

1.5.3 Data and Information Sources

Major sources for data and information were local contractors, international and local key professionals, regulatory body and international formwork producing and renting company (PERI). Many documents such as DVD's, product manuals and brochures were obtained from PERI, case company. An attempt was made for questionnaires to be filled by relevant experts on formwork construction in the company. Moreover, major information was collected from grade one to three of local contractors.

1.5.4 Data Collection and Analysis

The data which are used in this research are both primary and secondary. The primary sources are interviews and questionnaires. The information gathered through these two methods was supplemented by discussions based on literature review. Secondary data were obtained from company documents. The results obtained were also discussed based on literature review and actual observations made from local practice.

CHAPTER TWO

LITERATURE REVIEW

2.1 Definition of Formwork

A form is defined as a temporary structure or mold for the support of concrete while it is setting and gaining sufficient strength to be self-supporting. Formwork has a broader definition: it is the total system of support for freshly placed concrete including the mold or sheathing which contacts the concrete, as well as all supporting members, hardware, and necessary bracing. Forms are essential to concrete construction. They mold concrete to the desired size and shape and control its position, alignment, and surface contour. Formwork is more than a mold. It is a temporary structure that supports its own weight, the weight of the freshly placed concrete, construction loads such as materials, equipment, and workers, and other possible live loads during construction [7].

Different authors give definitions of formwork differently. For instance according to Hanna (1999) form and formwork have the same meaning. It is defined as a temporary structure whose purpose is to provide support and containment for fresh concrete until it can support itself. Other authors define formwork in relation to falsework as temporary or permanent molds into which concrete or similar materials are poured. And falsework as the structural supports and bracing used to support all or part of the formwork or structure [65]. In this thesis the definition made by ACI will be used. That is formwork includes all supports and face materials and form as face material only.

2.2 Requirements for Formworks

Economy, safety, speed and quality are some of the requirements to be fulfilled by formworks. These requirements will be described in the following sub-sections.

2.2.1 Economy

Formwork is the largest cost component for a typical multistory reinforced concrete building. Formwork cost accounts for 40 to 60 percent of the cost of the concrete frame and for approximately 10 percent of the total building cost in developed country. Figure 3.1a, b presents a breakdown of different cost categories for conventional concrete slab and wall formwork. A large proportion of the cost of conventional formwork is related to formwork labor costs in developed country. Significant cost saving could be achieved by reducing labor costs [30].

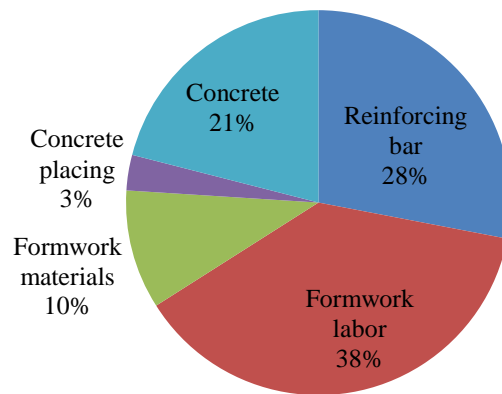

(a)

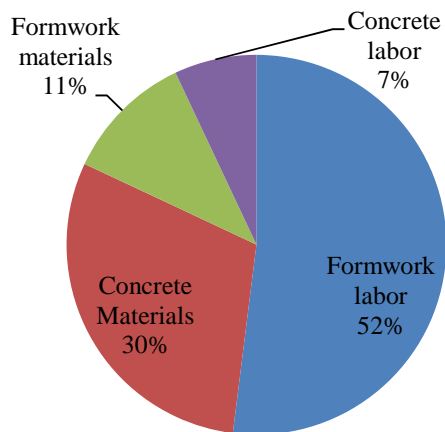

(b)

Figure 2.1 Distribution of costs for cast-in-place concrete (a) slab, (b) wall [11].

The proportion of cost of formwork varies from country to country. The percentages stated above are valid for developed countries like Germany. The situation for developing country, Ethiopia, might be totally different. The actual current proportion of the formwork cost in Ethiopia is established through this research and discussed in chapter four.

Formwork economy is achieved by considering four important factors:

- i. Cost of form materials
- ii. Ease of form fabrication
- iii. Efficient use of forms — erecting and stripping
- iv. Planning for maximum reuse to lower per use cost [7].

Formworks which are easy to erect and strip will reduce the overall completion of the project which leads to early collection of revenues to be generated from the building or other structure. Such economic benefits are obtained if the formworks are modern and efficient. Maximum reuse is obtained if the formworks materials are durable and handled well. The traditional formworks which need many blows of hammer to strike will not be durable as the material is threatened. Hence innovative formworks which can be easily striped, more durable and reusable should be used to ensure formwork economy.

Many scenarios should be considered in achieving cost effective formworks. These include:

- ✓ Cost and feasibility of adapting materials on hand versus cost of buying or renting new materials
- ✓ Cost of a higher grade of material versus cost of lower grade of material plus labor to improve for required quality and use
- ✓ Selection of more expensive materials that provide greater durability and capability for reuse vs. less expensive materials that have a shorter use-life.
- ✓ Building on-site versus building in a central shop and shipping to site (this depends on the site itself and space available, the size of project, the distance of shipping, etc.) [7].

The physical activities in the formwork life cycle are represented by these steps: (i) fabricate formwork; (ii) erect formwork; and (iii) remove formwork. First appropriate formwork material is chosen and fabricated to get the desired shape and size. After that the elements will be erected, concrete will be casted and forms will be stripped. By providing additional shores (reshore) it is possible to remove forms as early as possible. Finally, reshores will be removed after concrete supports its weight and additional live loads.

2.2.3 Quality

Many concrete-related problems such as discoloration, stains, and dusting are attributed to concrete formwork. Also, some deformed concrete surfaces are due to deformed formwork systems caused by repetitive reuse and inadequate support of formwork [30]. If the surface of the concrete is good, the cost of finishing to be applied on the surface will also be less. On the other hand if concrete surfaces are of less quality, which results from poor quality of formworks, cost of grinding and plastering will be higher. Therefore, formworks should fulfill the following quality requirements.

2.2.3a Strength

All components should be designed to cater for the most severe loads that are likely to be imposed on the formwork. To achieve this, the design should be done by a person competent in formwork design. Care should be taken to ensure that the design details are met and that the construction loads imposed on the formwork are within the limits designated by the designer. Sound materials should always be used. Reused material may be satisfactory, but should be checked regularly to ensure it is adequate for the job in the hand. The strength of each item of formwork material contributes to the overall safety of the temporary structure [16].

2.2.3b Stiffness, Accuracy and Water Tightness

Formwork should not bow, bulge, sag or otherwise move in such a way that the completed concrete element is outside the tolerances imposed for the work. The formwork designers should detail the units to have adequate stiffness, but site personnel are responsible for

ensuring that the correct, good quality materials are used in the proper manner. For example, plywood sheeting for general formwork use has a greater capacity in one direction than in the other. It should always be used in correct orientation.

In general, formwork should be built to accuracy greater than that desired in the finished concrete structure or element. All support structures should ensure that this accuracy is maintained until the concrete has hardened. The accuracy required may affect the selection of the material from which formwork is to be built as some materials may be finished to tighter tolerances than others. All joints should be sealed to stop grout leaking from the formwork. Grout loss causes ragged edges, hydration staining and honey combing, which in turn can affect strength, durability and appearance [16]. Formwork materials which have well defined engineering properties such flexural, compressive strength are believed to fulfill the above requirements. Therefore, standard and modern systems of the formworks are preferred to fulfill those quality requirements.

2.2.4 Safety and Health

Formwork operations are risky, and workers are typically exposed to unsafe working conditions. Partial or total failure of concrete formwork is a major contributor to deaths, injuries, and property damages within the construction industry. Structural collapses and failures involving concrete structures account for 25 percent of all construction failures. More than 50 percent of concrete structure failure during construction is attributed to formwork failure [30]. Though there is no proper documentation of the construction failure in Ethiopia, the percentage of collapses which are caused by defects in formwork construction is not less than the above figure. The possible health hazards related to formwork assembly, preparation and stripping are described in subsequent sections.

i. Sawdust: respiratory hazards

When plywood and other form materials are cut, there is exposure to wood dust. Cutting plywood containing laminates of hardwoods and softwoods generates particulate that, when

inhaled, can cause asthma and bronchitis. Formaldehyde containing adhesives can become airborne and be inhaled, causing irritation [19].

ii. Form oil: respiratory and other Health hazards

Workers will be exposed to form release oil sprayed on the formwork before concrete is placed. A variety of form oils can be used and the chemical content varies widely. Chemicals can include fuel oil, vegetable oil, water-based or oil-based solvents, or naphtha. Even though the material safety data sheet (MSDS) may say that the oil is “low VOC” (low in volatile organic compounds) or vegetable-based, workers may become sick or suffer adverse health effects if over-exposed. Direct contact can cause dermatitis [19]. Method of spraying formwork oils, especially in developing countries like Ethiopia, should be given attention to enhance safety of workers.

iii. Physical and other hazards

- *Falls* – They are the major hazard because they are potentially fatal. Cramped work areas, inadequate access, failure to install guardrails, failure to use fall arrest systems, tools or material left underfoot, and surfaces slippery from form oil can all lead to falls. Ladders are also frequently involved in falls. Workers must have fall protection whenever they are exposed to the risk of falling more than 3metres, or falling from any height into dangerous machinery, substances, or objects such as rebar. In some circumstances, you must use fall protection when the height is 2.4metres or more.
- *Struck by* – is common cause of injury. Rebar, formwork panels, concrete buckets, and other material hoisted overhead can strike workers. Struck-by injuries can also be caused by hammers, stakes, wedges, and material such as joists and panels during stripping. Another common hazard occurs during stripping of formwork in which loose formwork elements fall on workers under the concrete slab being stripped.
- *Collapses* – Even with advanced methods of design and installation, there is always the risk that slab forms, wall forms, and other large components can be loose, slip out

of place, or fall over, striking or crushing workers underneath. Refer the discussions under section 2.2.4a.

- *Environmental conditions* – Wind can be a major hazard. It makes handling sheets of forms more difficult, formwork panels may require more bracing, and hoisting gets harder, especially with large panels or tables [20].

2.2.4a Causes of Formwork Failure

Formwork failures are the cause of many accidents and building failures that occur during concrete construction, usually when fresh concrete is being placed. Generally some unexpected event causes one member to fail, then others become overloaded or misaligned and the entire formwork structure collapses [43].

The main causes of formwork failure are:

- *Faulty formwork structural design*
- *Improper stripping and shore removal:* Premature stripping of forms, premature removal of shores, and careless practices in reshoring can produce catastrophic results.
- *Inadequate bracing:* Inadequate cross bracing and horizontal bracing of shores is one of the factors most frequently involved in formwork accidents.
- *Vibration:* This occurs when shores are displaced by the vibration caused by passing traffic, movement of workers & equipment and vibrating concrete.
- *Unstable soil under mudsills* (A plank, frame, or small footing on the ground used as a base for a shore or post in formwork). Site drainage must be adequate to prevent a washout of soil supporting the mudsills.
- *Inadequate control of concrete placement:* The temperature and rate of vertical placement of concrete are factors influencing the development of lateral pressures that act on the forms; figure 2.3 shows the pressure distributions of concrete assuming it as fluid. If temperature drops in during construction operations, rate of concreting often has to be slowed down to prevent a buildup of lateral pressure overloading the forms. If this is not done, formwork failure may result. Temperature drop is major problem in

developed country and may not be applicable to Ethiopian case. Failure to regulate properly the rate and order of placing concrete on horizontal surfaces or curved roofs may also produce unbalanced loadings and consequent failures of formwork.

- *Lack of attention to formwork details:* Even when the basic formwork design is soundly conceived, small differences in assembly details may cause local weakness or overstress loading to form failure. This may be as simple as insufficient nailing, or failure to tighten the locking devices on metal shoring.

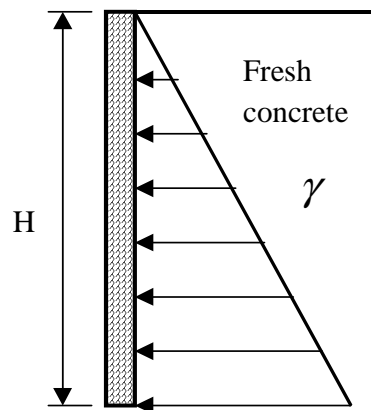

Figure 2.3 lateral Pressure Distributions of Concrete [43].

Contractors are generally responsible for stability and safety of concrete formwork. Contractors need to be guided by codes and regulations that regulate formwork safety. Contractors typically are trying to achieve fast removal of formwork elements without compromising the safety and integrity of structures. Proper planning of formworks will minimize the hazards associated with formwork preparation, assembly and removal [30].

Planning is the first and most important step in reducing hazards and preventing injuries. Because formwork operations must often be carried out in congested areas where other trades are also working, planning is essential in making the most of the time and space available to improve safety and efficiency. Planning is a must for fall protection, work platforms, material staging areas, and material handling and movement. It should take place at every level from

manager through supervisor to worker. Planning labor, materials equipment, and work schedules to meet design requirements is the responsibility of management and supervision. Workers must plan the details of their assigned tasks based on the most effective work methods and safety measures to follow in each case. Such practices need to be implemented in Ethiopia so as to avoid failures of the formworks. Besides planning, designing of formworks is crucial to alleviate problems in formwork construction.

2.3 Ethiopian Formwork Construction Systems

2.3.1 Introduction

The technology of formworks in Ethiopia is at an infant stage. This situation is attested through reviewing the construction practices of sites in all sub cities of Addis Ababa. Since the construction methods and materials used in all sub cities in particular and country in general is similar, representative sites in Addis Ababa are selected for review. As there are few literatures written on the formwork construction practices in our country, investigations from sites are considered as a review and presented in subsequent sections. Formwork construction practices for footing, column, slab and beam will be reviewed from quality, safety and environment aspect.

2.3.2 Footing Pad and Foundation Column Construction Systems

Formworks for footing pads can be either timber or steel panel. The steel panels are joined using black wire and supported from back by timber (see figure 2.4). In case of timber boards, the members are nailed together and supported from back in the same manner as that of steel panels. Formwork release agents, mainly burnt oil is usually applied on the panels and boards before placing of the formworks. Lean concrete is casted to form hard surface beneath the formworks which minimizes the settlement of the forms.

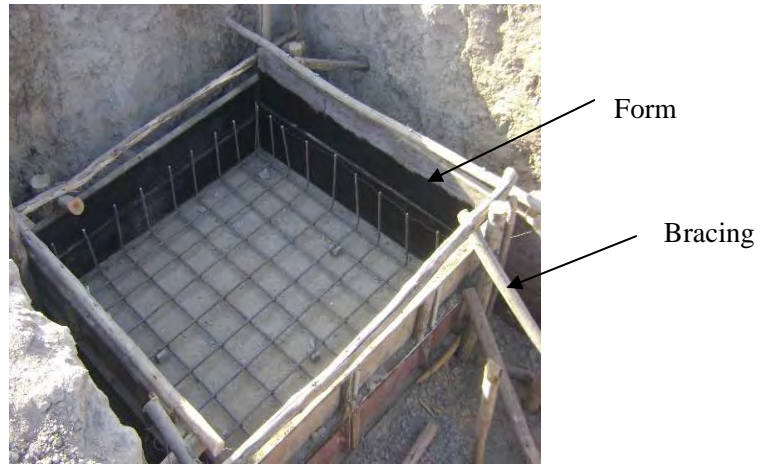

Figure 2.4 Footing pad formwork construction system in Addis Ababa

Column forms can be either timber or steel like that of footings'. The members are oiled and tied together using timber yokes supported by diagonal props. Wooden ladder is provided as an access for concreting. The following picture is taken from one of the high rise buildings in Addis Ababa which is constructed by local grade one contractor.

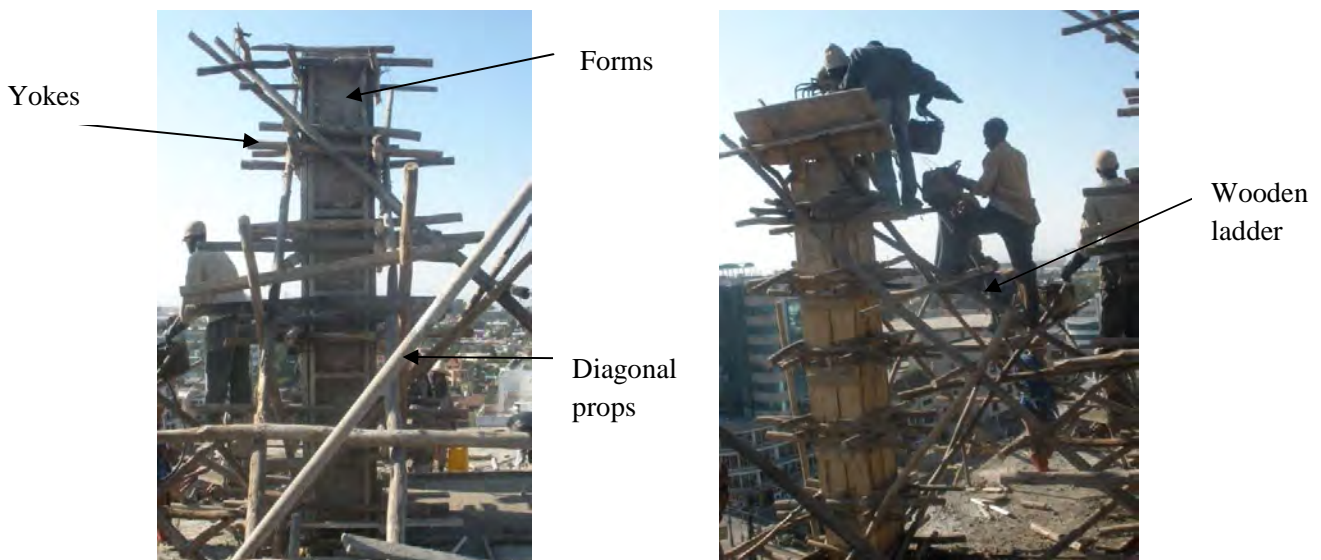

Figure 2.5 Column formwork construction systems in Addis Ababa.

Spacing of yokes differs from contractor to contractor. Some provide very closely which is not economical while others provide at relatively larger spacing which is not safe. This might be due to the lack of guidelines for the formwork design. As the timber is used intensively for yokes, ladder and props, the construction system is not environmentally friendly unless rapid replacement of trees are made. The platform system for concreting is not suitable to properly consolidate concrete. Vibrators are sometimes inserted diagonally as the working condition is not suitable for labor. This will result in segregation of concrete. Moreover, failure of the ladder may occur while concreting which make unsafe working conditions for the workmen.

2.3.3 Slab and Beam Formwork Construction Systems

Steel panels of different sizes such as 0.9m*2m, 1m*1m etc are used as forms for slab construction. Almost all contractors use wooden shores (see figure 2.6). A few contractors use steel in combination with wooden props. Some start to modify wooden props by providing metal shoes in which the props are inserted. This system will help them to easily remove the props. Few contractors in Addis Ababa have started to use modern formwork, Doka systems, for slab construction. It is possible to say that the current construction systems in Ethiopia are threatening the environment as mainly timber is deployed for slab and beam props. In most sites the props are very closely spaced and make the circulation underneath difficult.



Figure 2.6 Slab formwork construction systems in Addis Ababa.

Concerning beam formwork, the construction system is not different from others members. Timber boards and/or steel panels are used as sheeting material. Timber, mainly eucalyptus tree, props are used in Addis Ababa in particular and Ethiopia in general (see figure 2.7). The quality of concrete for beam and slab might be affected unless very experienced man power is employed in construction of beams and slab. The depth of the beam will be different at different points if all props for beam and slab are not precisely cut and placed. This problem is recurrent in most construction sites in Addis Ababa. More over the width of a particular beam might be different owing to the bulging of forms. Bulging may occur if the form ties are not properly designed. This phenomenon is also observed in most of our construction sites.



Figure 2.7 Beam Formwork Construction Systems in Addis Ababa.

2.3.4 Advantages and Disadvantages of Traditional Formwork Systems

Conventional formwork systems especially wooden formworks have the following merits and demerits [11].

Some of the advantages such systems are:

1. *Flexibility.* Because the system is built piece by piece, it is virtually capable of forming any concrete shape. A complicated architectural design can be formed by this system.
2. *Economy.* This system is not economical in terms of labor productivity and material waste. However, the system may be economical for small projects with limited potential reuses. The system has the advantage of low makeup cost or initial cost.

Also, for restricted site conditions, where storage areas are not available and the use of cranes is difficult, the conventional wood system might be the only feasible alternative.

3. *Availability.* Wood is a construction material that is available virtually anywhere. In areas where formwork suppliers are not available, a conventional wood system may be the only feasible alternative.

The major problems associated with conventional formwork systems are:

1. *Labor Intensive.* The conventional formwork system is a labor-intensive system and considered as demerit for developed country.
2. *High waste.* Erecting and dismantling conventional formwork is conducted piece by piece. This causes breaking of edges and deformation of wood. It is estimated that 5 percent waste is generated from a single use of formwork.
3. *Limited number of reuses.* Number of reuses is the key to an economical formwork construction. A limited number of reuses force the contractor to use several sets of formwork; this adds to the expense of formwork construction.
4. *Higher quality of labor force and supervision.* Conventional formwork systems work best with a high-quality labor force and adequate supervision. In areas with an unskilled or semiskilled labor force and minimal supervision, more sophisticated formwork systems are more appropriate.
5. *Limited spans.* Since dimension wood is low strength compared to that of aluminum and steel sections, it has limited use in applications where long spans are desired [11].

Since formwork systems in our country have the above limitations, it is the duty of stake holders in the construction industry to overcome the problems.

2.4 Classification of Formworks

Formwork can be classified according to a variety of categories; relating to the differences in sizes, the location of use, construction materials, nature of operation, or simply by the brand name of the products [18].

2.4.1 Classification According to Size

In practice, there are only two sizes for formwork; small-sized and large-sized. Any size which is designed for operation by workers manually is small-sized. The most common small sized systems are made of timber and aluminum, and are usually in the form of small panels. There is seldom medium-sized formwork. In cases where large-sized formwork is used, the size of the form can be designed as large as practicable to reduce the amount of jointing and to minimize the amount of lift.

2.4.2 Classification According to Location of Use

Different elements in the structure of building have different design and performance requirements in the use of formwork. Accordingly, classification can be made as wall formwork, column formwork, beam formwork and slab formwork [18].

2.4.3 Classification According to Nature of Operation

Formwork can be operated manually or by other power-lifted methods. Some systems are equipped with a certain degree of mobility to ease the erection and striking processes, or to allow horizontal movement using rollers, rails or tracks. Timber and aluminum forms are among the *manually-operable* types of formwork. They are designed and constructed in ways that they can be completely handled independently without the aid of any lifting appliances. However, it is labor intensive and is more appropriate to be used in simpler jobs. *Power-lifted* formwork can be of the self-climbing and crane-lifted types. Crane-lifted systems are usually in the form of large panels[18].

2.4.4 Classification According to Brand Name of the Product

Several patented or branded formwork systems have successfully entered the local construction market in the past decade. Some firms can even provide a very wide range of services including design support or tender estimating advice. As the use of innovative building methods gains more attention from various sectors in the community, advanced formwork systems will become more widely adopted [18].As there are numerous international

companies which produce patented formworks, only leading firms are discussed in the following sections. Appropriate company for the case study is selected after conducting the review of their products. The products are evaluated in terms of its adaptability and applications to developing countries. And the results are presented in chapter three.

2.4.4a MIVAN Formwork Systems

MIVAN is basically an aluminum formwork system developed by one of the construction company from Europe. In 1990, the MIVAN Company Ltd from Malaysia started the manufacturing of such formwork systems. Now a days more than 30,000 sq m of formwork used in the world are under their operation. MIVAN technology is suitable for constructing large number of houses within short time using room size forms to construct walls and slabs in one continuous pour on concrete. In this system of formwork construction, cast – in – situ concrete wall and floor slabs cast monolithic provides the structural system in one continuous pour. Large room sized forms for walls and floors slabs are erected at site. These forms are made strong and sturdy, fabricated with accuracy and easy to handle. They afford large number of repetitions, around 250[62]. Since such formwork systems are relatively costly and a few elements are available it is not chosen for the further investigation.

2.4.4b PERI Formwork Systems

PERI is one of the famous companies which produce modern formworks and scaffolds for the world construction industry. The company was found in 1969 at Weissenhorn southern Germany. Since 1974, PERI has expanded to new countries and markets. Currently there are about 48 international subsidiaries with numerous branch offices and over 100 logistic sites. PERI has established numerous products and system equipment on the market. The main products are Formwork Girders, different types of wall, column and beam formworks, patented concrete release agent, special formwork systems and others [49]. As compared to other formwork manufacturing firms, PERI has varieties of formwork systems. The material can be timber, steel and aluminum depending on need of clients. PERI is currently leading the world market in innovation as well as selling of formworks[49]. Therefore PERI is selected

among other companies for further investigation of its product. Case of PERI is presented in chapter three.

Moreover, sponsoring organization, DAAD, helped me a lot in studying the detail products of PERI which is found in Germany. On top of this, my advisor prof.christoph Motzko is a senior technical manager of PERI and access for information was very easy. Because of the above reasons, PERI was chosen as a case for study in this thesis.

2.4.4c Doka Formwork Systems

Doka is an Austrian company which has similar products as PERI. Doka Timber-beam floor formwork, Doka climbing systems, Doka formwork release agents and varieties of wall and column formworks are some of its products. Method of construction of Doka products is almost similar to that of PERI. Therefore, investigation of PERI's product will represent Doka's as the former is relatively more advanced.

2.4.4d Other International Formwork Systems

Other leading international formwork producing companies having patented trade name are TITAN (American system), WACO (Australian system) and FASI (Philippines systems). They produce varieties of timber, steel, aluminum and fiber glass formwork systems. Assembly mechanisms of such formwork systems are basically similar to PERI. Hence investigation of PERI system may represent world's modern formwork systems.

2.4.5 Classification According to Materials of Formwork

Before the final selection of the formwork material is made for a particular job, a number of factors should be considered, including:

- ✓ The size of the forms
- ✓ The shape of the forms
- ✓ The surface finish required
- ✓ The accuracy required
- ✓ The number of re-uses required
- ✓ The handling methods proposed

- ✓ The methods of compaction proposed
- ✓ The method of curing proposed
- ✓ Safety
- ✓ Speed of the project and the capital available.

The weighting given to each factor will vary from project to project. Thus on small projects where multiple uses of formwork elements are unlikely and a great deal of cutting and fitting may be required, timber sections may well be indicated. On major projects, where standardized components can be employed, and multiple re-use achieved, heavier steel sections may well be warranted. Modular units may be viable in such circumstances. The quality of the finish required and the overall cost of the formwork are likely to be the principal determinants [16].

Contractors in our country need to consider the above factors so as to have safe, quality and economical formworks. Moreover knowledge of all formwork materials is mandatory for the selection of best formwork system.

Many materials may be used for formwork. Plywood, steel, glass reinforced plastic, aluminum alloys, earth, precast concrete, particle board, hard board, gypsum board (for left-in-place sub grade forms), lumber, cardboard, rubber, polyvinyl chloride, and polystyrene are all used for forms and supporting formwork[7].Description of these materials is made in the following sections.

2.4.5a Steel Formwork

Steel is very strong and can be used repetitively without much damage done to the form. Steel forms are also in use in combination with timber. Steel sections are used in the fabrication of different formwork components, namely: steel panel forms, horizontal and vertical shores, steel pan and dome components used for joist and waffle slabs, and steel pipes for formwork bracing[30].Steel formwork has the following advantages and disadvantages.

- Advantages
 - Has very high reuse rates

- Very smooth surfaces are possible
- Strong and fast to install in simple walls.
- Disadvantages
 - Costs are 6-10 times plywood form.
 - Thicker the surface of the steel sheet, the greater the weight.
 - Steel dents easily
 - Release agents are demanded as, if not used, cleaning labor will quickly overcome any economy gained by durable surfaces.
 - Low versatility.

2.4.5b Aluminum Formwork

Aluminum has become an increasingly popular material for many formwork applications such as lightweight panels, joists, horizontal and vertical shoring, and aluminum trusses for flying forms. The popularity of aluminum stems from its light weight which reduces handling costs and offsets its higher initial material cost. When compared to steel panels, aluminum panels used for ganged forms weigh approximately 50 percent less. The major problem with aluminum forms is corrosion: Pure aluminum is attacked chemically by wet concrete. When aluminum is in contact with fresh concrete, a surface reaction does occur between the aluminum and the alkaline constituents of the concrete resulting in a slight superficial attack on the metal. Aluminum alloys have proven to be very successful in resisting corrosion [11].

Merits of aluminum formwork:

- I. In contrast to most of the modern construction systems, which are machine and equipment oriented, the formwork does not depend upon heavy lifting equipment and can be handled by unskilled labors.
- II. Fast construction is assured and is particularly suitable for large magnitude construction of respective nature at one project site.
- III. Construction carried out by this system has exceptionally good quality with accurate dimensions for all openings to receive windows and doors, right angles at meeting

points of wall to wall, wall to floor, wall to ceiling, etc., concrete surface finishes are good to receive painting directly without plaster.

- IV. System components are durable and can be used several times without sacrificing the quality or correctness of dimensions and surface [62].

2.4.5c Glass-Reinforced Plastic

Glass-reinforced plastic (GRP), also known as glass fiber-reinforced plastic (GFRP), is a composite material made of a plastic matrix reinforced by fine fibers made of glass. It is also known as GFK (Glasfaserverstärkter Kunststoff), or simply by the name of the reinforcing fibers themselves: fiberglass [65].

In recent years, forms fabricated from glass-reinforced plastic have found increasing use because of their strength, light weight, and high number of reuses. Glass-reinforced plastic also produces high-quality concrete finishes. They are very flexible and can form complex or nonstandard shapes with little capital investment. To fabricate glass-reinforced plastic forms, models of plaster, wood, or steel are prepared to the exact desired dimensions. The model is then waxed, polished, and sprayed with a parting agent to prevent sticking of the resin to the master pattern. Glass mat is then fitted over the model and thoroughly saturated with a brush coat of polyester resin. When the resin has set and the heat dissipated, another layer of glass mat and polyester resin is added, and this process is repeated until the desired thickness of the fiberglass sheet is achieved. The major problems associated with glass-reinforced plastic forms are attack by alkalis in the concrete and form expansion because of exposure to hot sun or heat from hydration of cement [11].

2.4.5d Concrete as Formwork

It is commonly called "pre-cast" concrete. Shapes that are built in such a way that when concrete is added it will build the final structural shape and are never "stripped"(permanent formwork).



Figure 2.8 Concrete as formwork material [43].

The main disadvantage of this system is that concrete is heavy and must be built strong enough to resist normal loads plus handling loads. Hence, there is increased re-bar in design of precast formworks to sustain the loads [62].

2.4.5e Stremaform Formwork

The fabrication and construction of joints/ stop-ends in reinforced concrete structures are often very difficult to construct on-site. The need for continuous reinforcement hinders access for formwork erection and for watertight structures the need for a metal, expanding or rubber bar water stops is an added complication. A stop end constructed using traditional timber or steel formwork is often difficult to fix. Stremaform can be used for all sizes of joint. The surface produced by Stremaform is equivalent to or better than one produced by conventional scabbling. The subsequent concrete pour binds to the rough face produced to provide a shear key. Independent testing confirms the very high shear transfer loads achieved. Stremaform is an expanded metal mesh embedded in reinforcing steel on both sides. It is prefabricated and supplied to the construction site ready for installation. It is the ideal lost formwork for producing quality joints in reinforced concrete. The main application of Stremaform is for concrete construction joints and for expansion joints [32].



Figure 2.9 Stremaform [32]

2.4.5f Cardboard Formwork

Cardboard tubes are the ideal solution for the creation of perfect circular columns. Circular columns are the preferred choice in modern public offices and buildings such as hospitals, educational facilities, airports, shopping malls and multi storey car parks, primarily for their aesthetics, safety and low maintenance requirements. FORM-A-ROUND circular cardboard tubes provide construction companies with:

- A fast, cost efficient and reliable method to create perfect round columns.
- Superior finish from fair face and standard versions.
- Left in place they protect new concrete from fast drying, frost and impact damage or staining.
- Pouring multiple columns together ensures color match and save time.
- No oiling is required and light in weight.

FORM-A-ROUND works on the same principle as plywood which has strength about 300% greater than traditional board of the same thickness. Thin reinforced cardboard strips are laminated together with special adhesives around a forming mandrel, producing a circular shape which does not bend under pressure. The circular shape ensures equal distribution of internal pressure as concrete is poured and sets.



Figure 2.10 Cardboard formwork [38]

Pouring of concrete should be done with a drop of less than 2metres at slow rate with poker vibrator working 0.5m below the pour level. The vibrator should not touch the sidewall. The formwork has coating on the inside to prevent concrete from sticking. Stripping is recommended in 48 to 72 hours after pouring, as the card board will still be soft and concrete will not have bonded to it. This retards loss of moisture and achieves excellent curing [38].

2.4.5g Plastic Formwork

Different companies innovate range of formwork products which is aimed at completely revolutionizing the concreting procedure by saving time and resources, while providing a smooth finish that is nothing short of excellent. Geoplast is one of such innovations. The products come in the form of Plastic panels that can be efficiently assembled into an airtight and minutely precise mould .Once the concrete is set, Geopanel are effortlessly removed to reveal the finished structure. All Geopanel pieces can be comfortably assembled by just one person this enables concrete structures to be erected with minimal manpower & tools. Needless to say, the necessity of cranes or other heavy lifting machinery is also eliminated. Furthermore since all moulds are produced from ABS (acrylonitrile, butadiene, and styrene)

Plastic they can be easily cleaned after use with just water and can be stored even in humid conditions. The following are some of the plastic column formworks [35].



Figure 2.11 Geoplast Plastic formworks [35]

2.4.5h Timber Formwork

Timber, arguably the original building material, retains its prime importance within the construction industry because of its versatility, diversity and aesthetic properties. About 20% of the earth's land mass is covered by forests, divided roughly two-thirds as hardwoods in temperate and tropical climates and one third as softwoods within temperate and colder regions. Approximately a third of the annual worldwide timber harvest is used in construction, and the rest is consumed for paper production, as a fuel, or wasted during the logging process.

In Ethiopia more than the figure stated for developed country is expected to be utilized for construction of structures. Almost all contractors use timber as false works and others which indicates that the construction industry of Ethiopia highly utilizes timber.

Environmental issues, raised by the need to meet the current and future demands for timber, can only be resolved by sustainable forest developments. In temperate climate forests, clear cutting, in which an area is totally stripped, followed by replanting, is the most economical, but the shelter wood method, involving a staged harvest over several years, ensures that replacement young trees become established as the mature ones are felled. The deforestation

of certain tropical regions has allowed wind and rain to erode the thin topsoil, leaving in hospitable or desert conditions; furthermore, the overall reduction in world rain forest areas is contributing significantly to the greenhouse effect by reducing the rate of extraction of carbon dioxide from the atmosphere.

Compared to the other major construction materials, timber as a renewable resource is environmentally acceptable. As illustrated in Figure 2.12 brick, steel, plastics and particularly aluminum all use more energy in their production, thus contributing considerably to carbon dioxide emissions. Trees require little energy for their conversion into usable timber, and young replacement trees are particularly efficient at absorbing carbon dioxide and releasing oxygen into the atmosphere. Temperate and tropical hardwoods, suitably managed, can be brought to maturity within a human lifespan; softwoods within half that period [9].

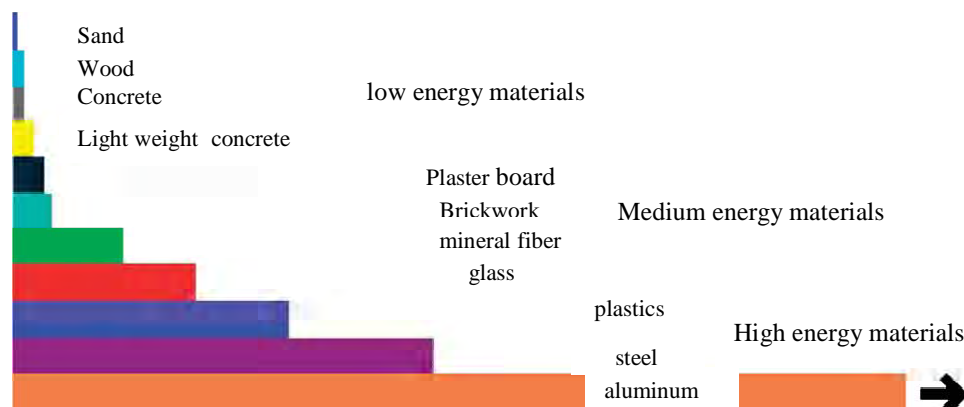

Figure 2.12 Embodied energy in building materials [9]

Timber can be best used for formwork if their replacement is promised. Otherwise it is a threat to Ethiopia's environment in particular and global environment in general.

The advantages of timber formwork are:

- a) Easy handling because it is light in weight

- b) Easy to disassemble
- c) Damaged parts can be replaced with new one
- d) Very flexible

The disadvantages of timber formwork are:

- a) Cannot be used for long period of time. They have limited re-use and can only be re-used 5 or 6 times
- b) If the timber is dry, it will absorb moisture from wet concrete which could weaken the resultant concrete member.
- c) Timber with high moisture content (more than 20 % moisture content) will shrink & cup, leading to open joints & leakage of grout.

2.4.5i Plywood Formwork

Plywood is used as sheathing that contacts concrete for job-built forms and prefabricated form panels. Since plywood comes in large sizes, it saves forming time. Plywood is made by gluing together thin layers of wood, called veneer, under intense heat and pressure. The grain of each ply is laid at a right angle to the adjacent pieces. This process gives plywood extra strength and reduces shrinkage and swelling. Plywood has particular orientations that affect their strength. A weak position can be achieved when the grain (face grain) is parallel to the span of support. A stronger orientation is seen when the grain (face grain) is perpendicular to the span of support see figure below [11].

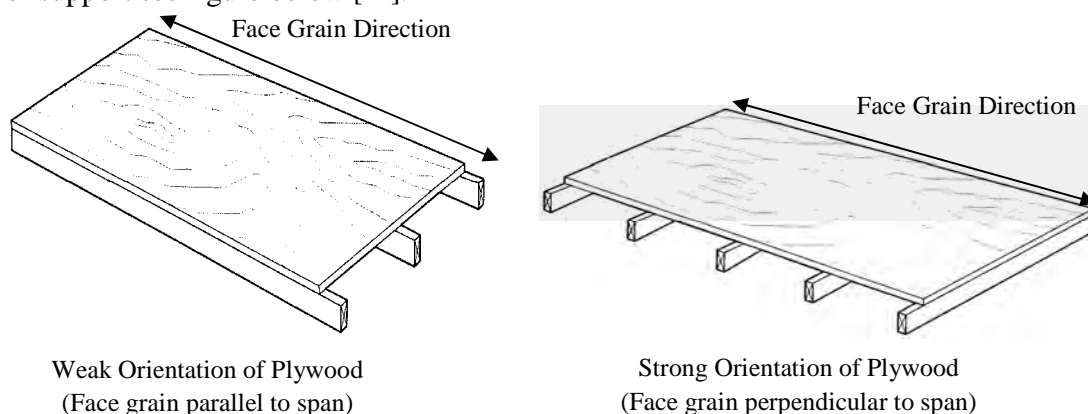

Figure 2.13 Plywood orientation [11]

2.4.5j Wood particleboard and Hardboard

Wood particleboard (chipboard) is manufactured from wood waste or forest thinnings, which are converted into wood chips, dried and graded according to size. The chips are coated with adhesive to approximately 8% by weight and then formed into boards (figure 2.14). The woods chips are either formed randomly into boards giving a uniform cross-section or distributed with the coarse material in the center and the finer chips at the surface to produce a smoother product. The boards are then compressed and cured between the plates of a platen press at 200°C [9]. Particle board is available with a plain sanded surface or covered with wood veneer, vinyl or melamine plastic. Building industry use particle board for concrete formwork, wall paneling, shelving and waterproof varieties are available for sheet flooring.

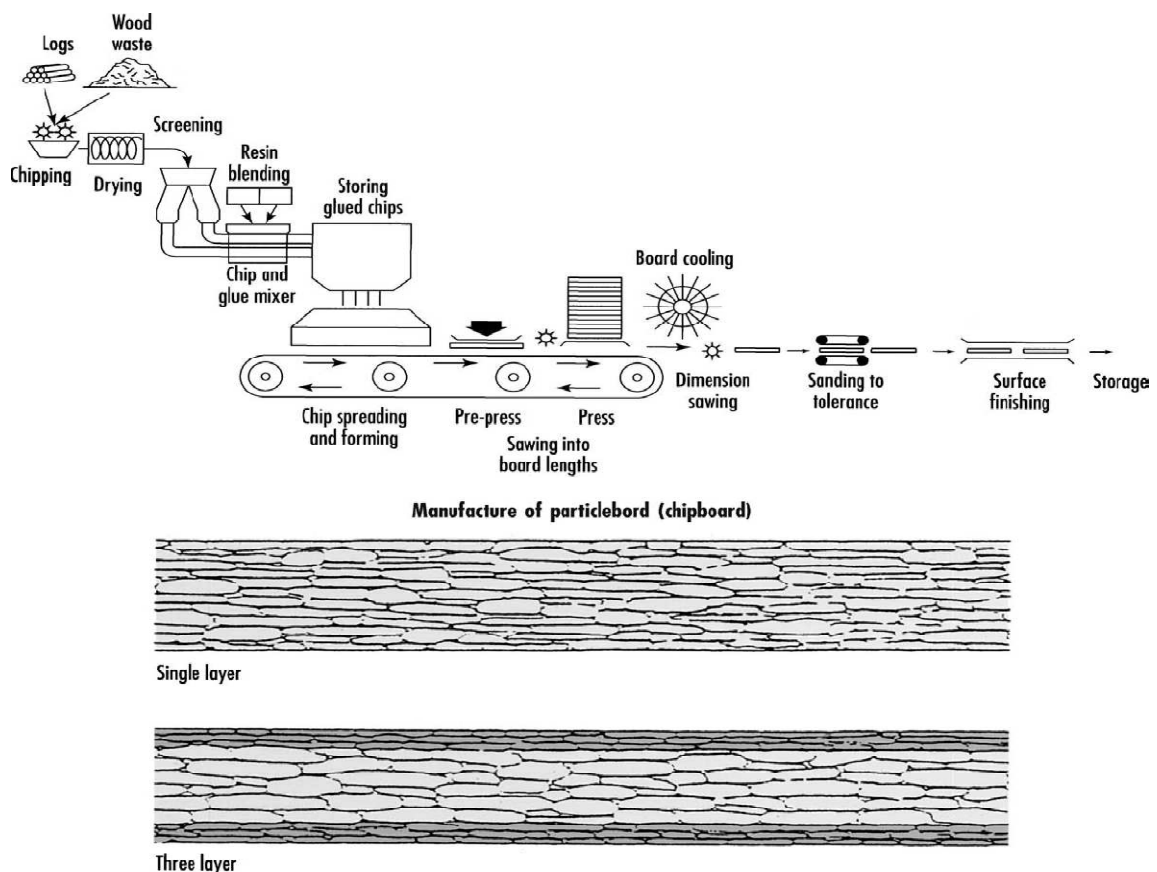

Figure 2.14 Manufacture and Standard Types of Wood Particleboard [9]

Hardboards are the densest fiber boards, with a minimum density of 900 kg/m^3 . Fibreboards are manufactured from wood or other plant fibers by the application of heat and/or pressure. Hardboards are bonded by the inherent adhesive properties and felting of the fibers. The boards range in color from light to dark brown, usually with one smooth surface and a mesh-textured surface on the underside, although duo-faced hardboard, smooth on two faces are available. Unlike particle board, hardboard is a fiber board which depends on the natural bonding of the fibers without added adhesive. High pressure is used to achieve a high density material.

2.4.5k Insulated Concrete Formworks

Insulating concrete formwork (ICF) is an innovative modern method of construction, which combines the inherent strength of concrete with the excellent thermal insulation properties of polystyrene to produce cost-effective and durable structures. The polystyrene is used as permanent formwork for the concrete and is available as either expanded or extruded polystyrene, in a variety of configurations and a number of proprietary systems. The basic structure is typically erected by a team of three or four site operatives and filled by pumping a very workable concrete in storey-height lifts. In addition to providing a strong structure, the concrete provides excellent sound and thermal insulation. There are four main systems: blocks, planks, panels and composites [5].

- i. Block Systems ICF:** Block types consist of a range of different sized and shaped components catering for commonly encountered building situations. The components fit tightly together to create a stable form, which contains the fluid concrete. The basic module consists of parallel sheets of Polystyrene, joined by cavity bridges acting as ties, forming a hollow block, which is filled with concrete (Figure 2.15).



Figure 2.15 ICF Block System [5]

ii. Plank Systems ICF: ICF plank systems share many of the characteristics of conventional formwork construction. These systems are inherently simple as there are only three basic components: the insulation planks, cavity ties and the rails or fixing channels, which locate the planks. The ties and rails are each available in a variety of sizes, which allow for different core and insulation thicknesses (see Figure 3.13).

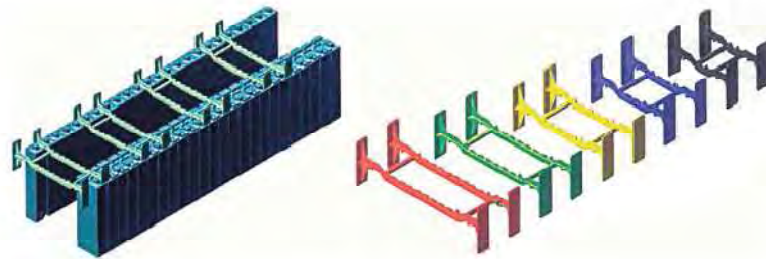

Figure 2.16 Separate planks tied together and a range of tie sizes [5].

iii. Panel Systems: The larger panel systems usually employ tongued and grooved Polystyrene sheets to adequately contain the fluid concrete without distortion at the panel edges. The panels are typically 1200mm long and 600mm high, tied together with galvanized steel mesh. The panels are pre-assembled and delivered to site ready to erect in accordance with the design.

iv. Composite wall systems: Some ICF systems are available as a composite system where one insulation face is replaced by a hard cement particle board to enable the full benefits of thermal mass to be utilized.

2.4.51 Permeable Formwork

Permeable formwork is a special class of lined formwork intended to produce improvements in the strength and durability of the surface of concrete. The bracing and the liner in the formwork are engineered to resist the pressure of plastic (or fresh) concrete, but to allow trapped air and excess water to pass through and be removed during concrete placement and consolidation (figure 2.17). The objective in using permeable formwork is to eliminate voids (bug holes) on the surface of the concrete and to increase the strength and durability of the concrete surface immediately behind the formwork [53].

The concrete cast against wood or steel has a reduced cement content and increased water/cement ratio (i.e. less dense and more porous) as compared to concrete located beyond the cover zone. During compaction process, excess mix water and air move outwards towards the formed surface and increase w/c ratio. As conventional wood and steel formwork is impermeable, the migration within the mix ceases as the concrete/formwork interface is reached [24].

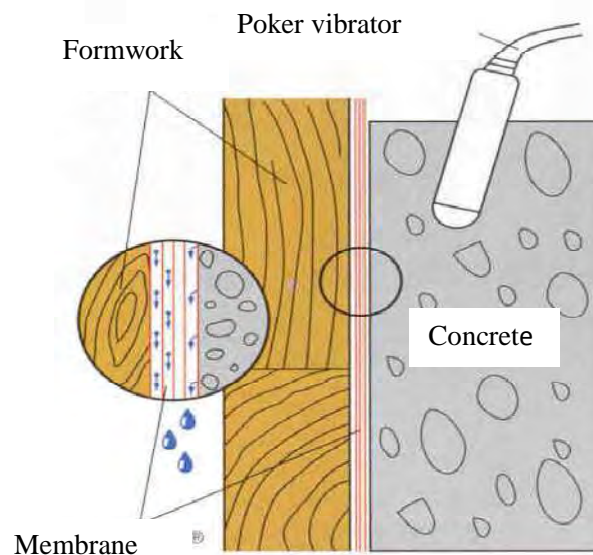

Figure 2.17 Action of Permeable Formwork [24].

In short permeable formwork has the following benefits:

- Reduction in Bug Holes and Surface Defects
- Improved Resistance to Freezing and Thawing
- Reduced Rate of Surface Carbonation
- Reduced Rate of Chloride-Ion Infiltration
- Increased Surface Strength
- Reduced Form Coating Requirements
- Reduced Efforts in Curing
- Reduced Surface Preparation for Coating

The goal in developing a liner is to have a material that will pass water and air without allowing the fine cement particles to escape. The filter material typically must be stiff enough to lay flat over a form or must be furnished with backing materials that prevent the fabric from wrinkling and provide a path for the water to move out of the form. Additionally, the filter unit must retain some water to keep the surface of the concrete moist as it cures. The filter must also be manufactured with a surface that will minimize the tendency of the filter material to adhere to the concrete. The ideal filter materials are those that can be reused several times before they wear out [53].

Pressed fiberboards (absorptive boards), Fabric-Covered Absorptive Form Liners and Woven Fabric Form Liners are some of the materials which are used as permeable formworks. Since such formworks are important for durability of concrete structures, local contractors are advised to use them.

2.4.5m Permanent Formworks

Permanent formwork, unlike traditional formwork, is left in place for the life of the element it is supporting. Insulated Concrete Forms and precast concrete are typical examples. There are two types of permanent formwork used:

- *Structurally participating*, which is designed to provide the temporary support for the wet concrete and construction loads and then become part of the permanent works

contributing to the strength of the completed element. This system consists of precast concrete units laid in rows. The space between the units are sealed using either mortar or other sealants.

- *Structurally non-participating*, which is designed solely to support the wet concrete and the construction loads. Glass fiber reinforced plastic (GRP) and glass fiber reinforced cement (GRC) are some of the materials used for such purpose.

Structurally participating formworks are nowadays common in Ethiopian construction industry. Condominium buildings consist of precast beams which act as formworks and finally became part of slab. Such systems, with better quality control, need to be encouraged so as to reduce the cost of formworks. Moreover slab concrete blocks are used as fillers between the precast systems and used as formwork too.

The use of permanent formwork has the following benefits:

- Eliminates the need for falsework
- Reduces the need for site skill levels
- Speeds up fixing time and eliminates stripping
- Allows early access for following operations [24].

2.5 Special Formwork Systems

2.5.1 Flying Formwork Systems

Flying (table) formwork is a relatively new formwork system that was developed to reduce labor cost associated with erecting and dismantling formwork. The name “flying formwork” is used because forms are flown from story to story by a crane. Flying form systems are best utilized for high-rise multistory buildings such as hotels and apartment buildings, where many reuses are needed. The basic construction sequence using this formwork is as follows:

- The assembled table formwork units are rolled in to position and sealed along the joints to form the floor to be cast.
- Steel reinforcement is fixed in place.
- Concrete is placed.

- Once struck, the formwork units are lowered and rolled out from underneath the newly formed slab.
- They are then taken by crane and placed at the next position or level.

Advantages of flying formwork systems are:

- Speedy construction for large floor layouts.
- Fully assembled units can be maneuvered quickly into place, rather than transporting individual components from one location to another and reassembling.
- High quality surface finishes can be achieved when appropriate quality control is used.
- The individual components of the formwork system are highly engineered and can be precisely adjusted.
- As the tables create large bay sizes the need for infill areas and decking joints is minimized. The high degree of repetition simplifies work practices.
- Reduced workforce requirement on site. However, the initial assembly of the formwork can be labor intensive depending on the size of the table unit [56].

2.5.2 Tunnel Formwork System

Tunnel form is used to form repetitive cellular structures, and is widely recognized as a modern innovation that enables the construction of horizontal and vertical elements (walls and floors) together. Significant productivity benefits have been achieved by using tunnel form to construct cellular buildings such as hotels, low- and high-rise housing, hostels, student accommodation, prison and barracks accommodation [56]. The tunnel formwork system consists of:

1. Deck panel: The thick steel skin used to form the ceiling and floor of each module
2. Wall panel: Also made of a thick steel skin, used to form the walls between two adjacent modules
3. Waler and waler splices: Stiffer deck and wall panels to minimize deflection due to concrete lateral pressure
4. Diagonal strut assembly: Used to provide additional support for the floor slab and keep walls and floors perpendicular.

2.5.3 Ganged Formworks

Ganged forms are large wall form units that are made of panels joined together with special hardware and braced with strong backs or special steel or aluminum frames. Gang forms can be made on the site, rented, or purchased from formwork manufacturers. The advantages of manufactured forms over site made is that they are precise in dimension and can be reused a larger number of times.

Sizes of gang forms vary substantially from smaller units that are handled manually to much larger units that are handled and raised by cranes. Smaller gang forms are typically 0.61 * 2.44m to 1.22 *2.44 m, and weigh between 23 and 45 kg. Larger gang forms are limited by crane carrying capacity and can reach 9.1 *15.2 m. smaller gang units are sometimes referred as “modular forms,” and larger units as “gang forms. ”Gang forms can be made of aluminum (all-aluminum), plywood face and aluminum frame, plywood face and steel frame, and steel. All-aluminum gang forms consist of aluminum sheathing supported by an aluminum frame along with intermediate stiffeners [11].

Advantages of Gang Formwork:

- Productivity of gang forms is higher than traditional forms because they are assembled on the ground and stripped as one unit.
- Gang forms produce high-quality smooth concrete with fewer joints. Also, form liners can be attached on the plywood to produce architectural concrete.
- Gang forms have higher reuse value than traditional all wood formwork systems. Also, plywood can be replaced without any need to replace the supporting frame.

Limitations of Gang Formwork:

- The major limitation of gang formwork is that before moving gang forms vertically or horizontally to the next pouring position, they have to be brought down to the ground for cleaning and oiling. This process substantially increases the cycle time between two lifts.
- Gang forms are not suitable for small walls or walls interrupted by pilasters.
- Because of their large sizes, safety is a major concern when moving ganged forms.

2.5.4 Jump Formworks

Jump form systems are used where no floor is available on which to support the wall formwork, or the wall and column proceed ahead of the floor. Jump forms consist of a framed panel attached to two or more strong backs. Generally, jump form systems comprise the formwork and working platforms for cleaning/fixing of the formwork, steel fixing and concreting. The formwork supports itself on the concrete cast earlier, so does not rely on support or access from other parts of the building or permanent works. Jump form, here taken to include systems often described as climbing form [56].

Three types of jump form are in general use:

- i. Normal jump/climbing form – units are individually lifted off the structure and relocated at the next construction level using a crane.
- ii. Guided-climbing jump form – also uses a crane but offers greater safety and control during lifting as units remain anchored/guided by the structure.
- iii. Self-climbing jump form – does not require a crane as it climbs on rails up the building by means of hydraulic jacks, or by jacking the platforms off internal recesses in the structure. It is possible to link the hydraulic jacks and lift multiple units in a single operation.

2.5 .5 Slip Formworks

Slip form is similar in nature and application to jump form, but the formwork is raised vertically in a continuous process. It is a method of vertically extruding a reinforced concrete section and is suitable for construction of core walls in high-rise structures, lift shafts, stair shafts, towers, etc. Fresh concrete is placed or pumped into the forms. After two to three hours, the concrete reaches the initial set and loses its plasticity and starts supporting the newly fresh concrete above. The rate of movement of the forms is controlled and matches the initial setting of concrete so that the forms leave the concrete after it is strong enough to retain its shape while supporting its own weight. The forms move upward by mean of jacks climbing on smooth steel rods embedded in the hardened concrete and anchored at the concrete foundation base [56].

Ethiopian cities, especially Addis Ababa, are growing very fast. High rise buildings and other structures are being constructed to fulfill the needs of the growing population. To make the construction of such structures safe, quality and achieve early completion time; the use of special formwork systems plays an important role.

2.6 Formwork Hardware

2.6.1 Form Ties

Ties are devices used to hold the sides of concrete forms together against the fluid pressure of fresh concrete. Ties are loaded in tension and have an end connector that attaches them to the sides of the form. In order to maintain the correct form width, some ties are designed to spread the forms and hold them at a set spacing before the concrete is placed. Some ties are also designed to be removed from the concrete after it sets and after the forms have been removed. These ties take the form of tapered steel rods that are oiled or greased so they can be extracted from one side of the wall. They usually have high strength and are used in heavier panel systems, where it is desirable to minimize the total number of ties. Another type of tie is designed to be partially removed by either unscrewing the tie ends from a threaded connector that stays in the concrete or by breaking the tie ends back to a point weakened by crimping. Some ties have waterstops attached. These would be used if ordinary grout patching will not provide a watertight seal. Nonmetallic ties have recently been introduced. They are produced of materials such as a resin-fiber composite and are intended to reduce tie-removal and concrete-patching costs. Because they are made of nonmetallic materials, they do not rust or stain concrete. The rated strength of ties should include a factor of safety of 2.0. ACI Committee 347 revised previous recommendations that called for a factor of safety of 1.5 for ties. When specifying ties, the manufacturer's data should be carefully checked to ensure that the required factor of safety is incorporated within the rated capacity [64].

The most common type of tie rod is the *through tie* (Figure 2.18). It comprises a threaded bar, generally of 15 mm diameter, passed through an expendable plastic tube. Simple plastic cones are fitted at the ends of the tube. After use, the bar is removed and re-used. The load taken by

the bar can be large and waler plates of sufficient size will be required to spread the load into the backing formwork members. The expendable tube not only acts as a spacer ensuring the correct width of wall required, but allows easy removal of the tie bar after pouring. The plastic tube should be accurately cut to length to reduce grout loss on the surface of the concrete. The tube will leave a hole through the wall and will generally need to be plugged after striking the forms [47].

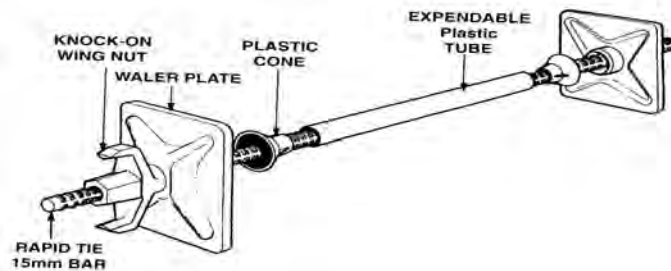

Figure 2.18 Through Tie System [47]

The *lost tie* system leaves the tie rod in the wall (Figure 2.19). The threaded ends of the tie rod are screwed into tapered ends of the 'she bolt'. This allows the entire assembly to be placed through the wall from one side during form erection, and permits the she bolts to be removed. The length of the lost tie rod is specified to suit the cover to the reinforcement. They are a quick and high-capacity tie system, but the tie rods have to be procured to the right length. As the tie is only loaded once, a typical factor of safety of 1.5 is used on these high tensile steel 'lost' ties [47].

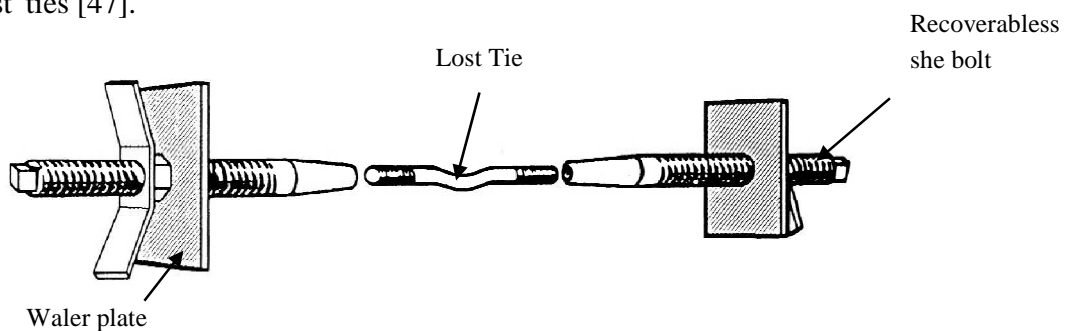

Figure 2.19 Typical lost tie assembly [47]

2.6.2 Form Anchors

Form anchors are devices embedded in previously placed concrete, or occasionally in rock, that may be used to attach or support concrete formwork. There are two basic parts to the

anchors. One part is the embedded device, which stays in the concrete and receives and holds the second part. The second part is the external fastener, which is removed after use. The external fastener may be a bolt or other type of threaded device, or it may have an expanding section that wedges into the embedded part. Figure 2.20 shows the typical anchor system.

For anchors supporting only concrete and dead loads of the forms, a factor of safety of 2 is used. When the anchor also supports construction live loads and impact loads, a factor of safety of 3 should be used. The rated capacity of various anchors is often given by the manufacturers. Their holding power depends not only on the anchor strength but on the strength of the concrete in which they are embedded. The depth of embedment and the area of contact between the anchor and concrete are also important in determining capacity. It is necessary to use the data provided by the manufacturers, which are based on actual load tests for various concrete strengths, to determine the safe anchor working load for job conditions. This will require an accurate prediction of the concrete strength at the time the anchor is loaded. Estimated concrete strengths at the age when anchor loads will be applied should be used to select the type and size of anchor required [47].



Figure 2.20 Uni -Sleeve anchor System [33]

2.7 Form Release Agents

Release agents are essential in the production of satisfactory concrete work, their prime function being to effect release of the form from the concrete surface and reduce the likelihood of surface damage to concrete and formwork. If painting or other treatment is to be carried out on the surface subsequently, then information should be sought from manufacturer

of the release agent to ensure that there will be no contamination of concrete surface. However, if applied excessively they can induce such undesirable features as staining, poor surface durability, efflorescence and color variation [25].

A good release agent should:

- Provide a clean and easy strike without damage to either the concrete face or form
- Contribute to the production of blemish free concrete surface.
- Have no adverse effect on either the form or concrete.
- Assist in obtaining maximum reuse of forms.
- Not inhibit adhesion or penetration of any subsequent finish applied to the formed concrete surface.
- Be inoffensive to the operative with regard to odor, skin staining, etc.
- Be suitable for use in the anticipated weather conditions.

Release agents are classified in many ways by different standards and authors. In this chapter the classification made by concrete society of UK will be used. Accordingly, the following are some of the form release agents:

- i. Neat oils:** They are usually mineral oils, which tend to produce blowholes and are not recommended for use for the production of high quality concrete surfaces. They are used for concrete which will be hidden below ground.
- ii. Neat oils with Surfactant:** Mineral oils or synthetics with the addition of small amount of surface activating or wetting agent minimize blowholes and have good form penetration and resistance to climatic conditions.
- iii. Mould Cream Emulsions:** emulsions of water in oil normally tend to be removed by rain from sealed form faces, but minimize blowholes and are good general purpose release agents.
- iv. Water-soluble Emulsions:** Most emulsions of oil in water produce a dark porous skin on the concrete which is not durable. They are not recommended for good class work and are seldom used. But water soluble emulsions show much improved properties, and

are environmentally more friendly. As these products are water based they require protection from frost.

- v. **Chemical Release Agents:** These are small amounts of chemical suspended in a low viscosity oil distillate. The chemical reacts with cement to produce a form of soap at the interface. Recommended for all high quality work, they should be applied lightly by spray to avoid excessive concrete surface dusting. Increased cost is compensated for by better coverage compared with the oil based materials. They generally have good weathering resistance.
- vi. **Paints, lacquers, waxes and other surface Coatings:** These are not strictly release agents but sealers which prevent release agents being absorbed into the form face. They are useful where it is necessary to avoid uneven porosity with consequent color variations in the concrete; particularly useful are the wax treatments. They can also increase the number of uses obtained from the formwork [25].

2.8 Stripping of Formwork

The designer and contractor can have conflicting goals over when to remove forms. The designer wants the maximum strength gain, while the contractor wants to strip and reset (cycle) forms as soon as possible to improve the schedule and maximize form reuse. Forms can usually be removed when the concrete is strong enough to carry its own weight and any construction loads it will have to support without deflection beyond specified limits. The engineer should specify the minimum concrete strength to be attained before removal of forms or shores [7]. American Concrete Institute (ACI), British Standard, German Standard and Ethiopian standards recommendations for formwork removal is reviewed in this chapter.

2.8.1 ACI Recommendation

ACI's "Guide to Formwork for Concrete" (ACI 347R) recommends that engineer specified criteria based on strength gain is used to determine form removal time. In the absence of such criteria, the guide contains recommendations for the length of time that formwork should remain in place when the air temperature is above 10°C (Table 2.1). The time need not be

consecutive, but it is the total time during which the temperature is above 10°C. When high-early-strength cement is used, these times can be shortened. When air temperatures remain below 10°C or retarding admixtures are used, these times should be lengthened. Unusually heavy construction loads may require longer times before form removal.

Table 2.1 ACI General Guidelines for Form Stripping Times [7]

Member	Time	
Walls	12hrs	
Columns	12hrs	
Sides of beams or Girders	12hrs	
<i>Joist ,beam, or girder bottoms</i>	Where design live loads are:	
	< dead load	>Dead load
	7days	4days
	14days	7days
Under 10ft(3m) clear span		
10 to 20ft clear span	21 days	14days
<i>One way floor slabs</i>		
Under 10ft clear span	4 days	3 days
10 to 20ft clear span	7 days	4 days
Over 20ft clear span	10 days	7 days
<i>Two way floor slabs</i>	Contingent on reshores being placed immediately after stripping.	

2.8.2 British Standards Recommendations

The time at which the forms can safely be removed is related to the material of the form and the gain in strength of the concrete. This strength gain is governed by the mean concrete temperature, the mix design, method of curing etc. When finish and uniform color are important, a consistent timing regime of striking and curing will be critical.

A minimum value of in-situ concrete cube strength of 2 N/mm² is generally recommended to reduce the risk of mechanical and frost damage to finishes while striking vertical formwork. A minimum period of 8 hours at 20°C for unsealed plywood or 6 hours at 20°C for impermeable formwork such as overlaid or film coated plywood, steel forms etc. The temperature is concrete temperature. In practice if the temperature of concrete is above 10°C overnight the vertical formwork can be struck next morning. Summary of the BS recommendation for concrete made with Portland cement 42.5 and sulfate resisting Portland cement 42.5 are shown in table below.

Table 2.2 Minimum Period before Striking Formwork as Per BS [14]

Type of Formwork	Minimum Period Before Striking	
	Surface temperature of concrete	
	16°C and above	t°C (any temperature between 0 and 16°C)
Vertical formwork to columns, walls and large beams	12h	300/(t+10) h
Soffit formwork to slabs	4 days	100/(t+10) days
Soffit formwork to beams and props to slabs	10 days	250/(t+10) days
Props to beams	14 days	360/(t+10) days

British Cement Association, the required strength of a concrete slab for striking depends on:

- Characteristic design service load.
- Construction load
- Characteristic concrete design strength
- Actual concrete characteristic strength at the time of striking.

The formula for calculating the required early striking strength as per the association's recommendation is determined as follow:

Determination 1: $W/W_{ser} \leq 1.0$ (*)

Determination 2: $f_c \geq f_{cu} (W/W_{ser})^{1.67}$ (**)

Where: W_{ser} is the total unfactored design service load, kN/m^2 ; W is the total unfactored construction load on the slab considered, kN/m^2 ; f_c is the required characteristic concrete strength to be able to strike the flat slab, N/mm^2 ; f_{cu} is the characteristic strength of the concrete, N/mm^2 .

2.8.3 German Recommendations

Hoffmann in his book provides recent guide line for formwork stripping times for elements casted with different Portland cements (table 2.3).

Table 2.3 Guideline for Formwork Stripping Times as per German Standards [46]

Formwork Type	Cement Type		
	32.5	32.5R, 42.5	42.5R,52.5, 52.5R
	period before striking ,in days		
Vertical formwork to columns and walls ;side formwork for beams	3	2	1
Soffit formwork to slabs	8	5	3
Props to beams and slabs	20	10	6

2.8.4 Ethiopian Standards Recommendations

The time between casting and removal of the formwork depends mainly on the strength development of the concrete and on the function of the formwork. In the absence of more accurate data, the following minimum periods are recommended:

Table 2.4 EBCS 2 Recommendation for Formwork Stripping Times [31]

Form Work Type	Duration
non-load bearing parts of formwork (vertical formwork of beam; formwork for columns and walls)	18 hours
soffit form work to slabs	7 days
props to slabs	14 days
soffit formwork to beams	14 days
props to beams	21 days

2.8.5 Comparison of Recommendations for Formwork Stripping Times

From the reviews made in the previous sections the following summary is made.

- ACI and BS specify similar stripping time, 12hrs, for formworks of vertical members. While EBCS and German standards recommend relatively longer time.
- The type of cement is not clearly specified for EBCS.
- German standards provide stripping times for relatively different cement types than others.
- BS sets two determinations which helps to compute the strength of concrete before removal of formwork. While other standards did not provide guideline for computation of the required characteristic strength. Hence British standard outweighs the others in this aspect. Analysis of required strength and/or time for concrete casted with different cement in Ethiopia is made in chapter four of this thesis.

2.9 Selection of Formworks

Selecting the formwork system for cast in place reinforced concrete is a critical decision that can affect cost, safety, quality, and speed of construction. Many factors must be considered for the proper selection of the formwork system. Among these are:

1. Factors related to building architectural and structural design, which include slab type and building shape and size.
2. Factors related to project (job) specification, and schedule, which includes the speed of construction.
3. Factors related to local conditions, which include area practices, weather conditions, and site characteristics.
4. Factors related to the supporting organizations, which include available capital, hoisting equipment and availability of local or regional yard supporting facilities [11].

2.9.1 Building Design and Shape

The construction cost of slabs is often more than half the cost of structural framing systems, except in extremely tall buildings. Therefore, selection of the slab formwork system deserves considerable attention to minimize cost. The selection of a formwork system should be made

on the basis of the selected floor system that satisfies the structural loading conditions. Selection of the types of slab has an impact on the cost of formworks. For instance construction of two way slabs supported by the drop beams is relatively complex and more costly.

Concerning building shape for instance special buildings such as industrial buildings and power plants usually have extensive electrical and mechanical requirements which do not lend themselves to any sophisticated formwork system. As a result, they should be constructed using the traditional formwork method. Some of the shape factors that enable the contractor to decide whether to use a formwork system or a traditional forming method are:

- Variation of column and wall location
- Variation of beam depth and location
- Variation of story height
- Existence of openings for windows and doors
- Extensive HVAC requirements [11].

Designers play great role in minimizing the cost of formwork. Ease of construction should be considered besides safety, aesthetics and other design requirements.

2.9.2 Job Specification

The most important advantage of using a modern formwork system is the speed of construction. The speed of construction affects cost because it determines the time when the building will be available for use and also reduces the financial charges. The major factor that determines the speed of construction is the floor cycle time. In recent years, casting two floors or more per week in high-rise buildings has been achieved, especially in metropolitan areas. This fast floor cycle can only be achieved by using sophisticated formwork techniques such as flying forms and tunnel formwork which are capable of forming one story every two days.

2.9.3 Local Conditions

The nature of the job, including local conditions, is one of the primary factors in formwork selection. Some of the factors that should be considered are explained below.

2.9.3a Area Practice

In geographic areas where the labor force is expensive and unskilled, the use of formwork “systems” can substantially reduce the cost. In areas where the labor force is inexpensive and skilled, a conventional formwork system is an economical alternative even if the building features are compatible with a sophisticated formwork system. As a result, some geographic areas use preassembled formwork systems because of the lack of inexpensive skilled labor force.

2.9.3b Site Characteristics

The building site itself may influence the selection of a suitable forming system, because of site limitations and accessibility for construction operations. The feasibility of using flying forms, for instance, is influenced by site characteristics, which include:

- Accessibility to the site.
- Availability of a fabrication area.
- Surrounding area restrictions such as property lines, adjacent buildings, power lines, and busy streets. In open and unrestricted suburban sites, all forming systems are practical and some other considerations should be evaluated to determine the most efficient and cost-effective system. In downtown restricted sites, the only possible system may be ganged units that can be transferred from floor to floor.

2.9.4 Supporting Organization

Most of the crane-set formwork systems (i.e. flying form, and tunnel), require high initial investment and intensive crane involvement. The major resource requirements that should be carefully evaluated when deciding upon a forming system are discussed below.

2.9.4a Available Capital

The cost of concrete formwork is influenced by three factors:

1. Initial cost or fabrication cost, which includes the cost of transportation, materials, assembly, and erection.
2. Potential reuse, which decreases the final total cost per meter of contact area. The data in Table 2.5 indicates that the maximum economy that can be achieved by maximizing the number of reuses.
3. Stripping cost, which also includes the cost of cleaning and repair. This item tends to remain constant for each reuse up to a certain point, at which the total cost of repairing and cleaning start rising rapidly.

Table 2.5 Effect of Concrete Formwork Cost Based on one use equal to 1.00[11]

Number of uses	Cost per square foot of contact area	Cost per square meter of contact area
One	1.00	10.76
Two	0.62	6.67
Three	0.50	5.38
Four	0.44	4.74
Five	0.40	4.31
Six	0.37	3.98
Seven	0.36	3.88
Eight	0.35	3.77
Nine	0.33	3.55
Ten	0.32	3.44

In deciding to use a specific formwork system, the initial cost should be evaluated versus the available capital allocated for formwork cost. Some formwork systems tend to have a high initial cost, but through repetitive reuse, they become economical. For example, slip forms have a high initial cost, but the average potential reuse (usually over 100) reduces the final cost per square meter of contact area of this alternative. In the case of rented formwork systems, the period of time in which the formwork is in use has a great effect on the cost of formwork [11].

2.9.4b Supporting Yard Facility

The feasibility of using prefabricated forms such as flying formwork is largely influenced by the availability of a local or central (regional) yard facility. When a local or central yard facility is available, the standard formwork elements can be manufactured and assembled under efficient working conditions. However, the cost of transporting form sections to the site may influence the economy of the selected system [11].

Some formwork systems require special handling techniques, which can include a good crane service. The flying truss system is a good example of crane influence on the selected system. The size of the flying modules may be limited by the crane carrying capacity and its maximum and minimum lift radii.

CHAPTER THREE

CASE STUDY

3.1 Introduction

In previous chapter review of the international formwork producing companies were made and PERI was selected for further investigation of its product. The detailed description of the products and discussion on suitability for Ethiopian construction industry will be made in subsequent sections of this chapter.

It is known that the costs of formworks are shaped by the working methods, the features of the structure and the wage levels of the market. This clearly shows where the success of promising rationalization potential is in order to lower the costs for the realization of concrete structures. It is for this reason that PERI has successfully established numerous products and system equipment on the market. The following are some of the products of PERI which will be further discussed in this chapter:

- Formwork Girders
 - ✓ GT 24 formwork Girder
 - ✓ VT 20k form work Girder
- Wall Formworks
 - ✓ MAXIMO panel formwork
 - ✓ TRIO panel formwork
 - ✓ DOMINO panel formwork
 - ✓ RUNDFLEX circular formwork
 - ✓ HAND SET panel formwork
 - ✓ VARIO GT 24 Girder Wall Formwork
- Column Formwork
 - ✓ RAPID column formwork
 - ✓ QUATTRO column formwork

- ✓ SRS circular formwork
- Slab Formworks
 - ✓ SKYDECK panel slab formwork
 - ✓ GRID FLEX Grid “
 - ✓ MULTIFLEX Girder “
 - ✓ Slab Tables
 - ✓ SKYTABLE Slab formwork
- Beam Formwork
 - ✓ UZ Beam formwork
- Climbing Systems
 - ✓ CB240 and CB160 climbing systems
 - ✓ RCS Rail Climbing Systems
 - ✓ ACS Self climbing systems
- Plywood Form lining and system independent Accessories
 - ✓ Plywood form lining
 - ✓ Peridian Fabric
 - ✓ Concrete Release Agent

Many aspects of PERI activities promote the economic and ecological sustainability of its products and solutions. Procurement takes place in accordance with the ecological sustainability, for instance timber from certified growing regions is used. The certificate confirms that harvested forest areas are constantly reforested. New technologies and efficient processes in the production ensure resource saving manufacturing. More over economically optimized formwork and scaffolding solutions minimize the use of materials on construction sites and make a valuable contribution in avoiding waste.

3.2 Formwork Girders

Formwork girders are versatile materials which can be used for walls and slabs. The two main products are GT 24 and VT 20k.

3.2.1 GT 24

This girder is a central component for slab and wall formwork systems and choosing the right one is crucial in achieving the highest possible level of cost effectiveness. Through the high load bearing capacity and rigidity fewer girders and or props are required for both wall and slab formwork. It also reduces labor costs as fewer girders are required. As it is shown in the following picture, codes like year of manufacture, day of production and length in centimeters are written on the girders. Moreover string impact protection is provided by the steel end caps and side to side rivets.



Figure 3.1 GT 24 Girder

This girder offers a number of advantages to the customers:

- Light and manageable for slabs: The use of the universal, rigid and durable GT 24 lattice formwork girder allows large spans which then reduces the number of components required for shuttering and striking.
- Strong enough for walls: Regardless whether it is industrial or housing construction, bridge abutments or retaining walls, any ground plan and all heights up to 18 m can be shuttered with one panel using the GT 24.
- Other advantages like long service life due to the robust design with 80 x 60 mm thick chords, patented girder nodes with mini dovetail jointing, steel end caps and side to side steel rivets.

These girders are available in lengths from 90 cm to 17.80 m, in 30 cm increments. The elements can be extended by means of the extension splice up to 8.10m. Mounting the splice takes place without drilling holes in the girder (figure 3.2) parts are simply joined through the lattice work.

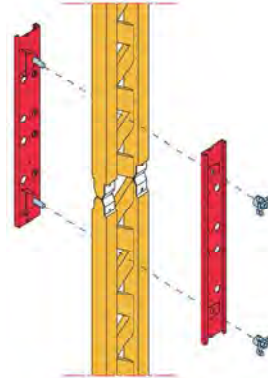

Figure 3.2 Girder extension

3.2.2 VT 20k

The PERI VT 20K is the 200 mm solid web girder complete with optimal protection at the girder ends (figure 3.3). The robust steel cap which surrounds the end of the girder, as well as the concave web end, reliably prevent damage to the girder ends in demanding and tough conditions on the construction site. Here, the natural elasticity of the timber is used to absorb the impact energy if the girder falls to the ground. The highly compressed web board has a high proportion of synthetic resin which ensures high dimensional stability. These improvements in the details, in connection with chords made of high quality Nordic softwood, greatly extend the service life of the girder



Figure 3.3 VT 20K Girder

The properties of GT 24 and VT 20 K are summarized in the following table.

Table 3.1 Comparison of VT 20K and GT 24

Properties	VT 20K	GT 24	Difference (%)
Permissible reaction	22 kN	28 kN	+27%
Permissible bending moment	5 kNm	7 kNm	+40%
Weight	5.9 kg/m	5.9 kg/m	0%

Both girders are versatile formwork elements for concrete construction, mainly for slab and circular walls (water reservoirs), in our country. To minimize the cost, similar girders which are made of local materials can be manufactured to substitute the functions of GT24 and VT20K girders. Mechanical properties of such members need to be determined so as to know the permissible loads. This can be an area of research for the future.

3.3 Wall Formworks

3.3.1 MAXIMO Panel

The MAXIMO panel formwork succeeds in minimizing imperfections in the concrete finish and creates a neat joint and ties arrangement. By means of a newly developed conical tie system, the wall formwork system does not require any spacer tubes and work takes place from only one side (figure 3.4). That is there is no need to have worker on the opposite side of the wall. This means maximum reductions in expense and considerable savings of time and resources.

Apart from the advantages of a panel formwork regarding flexibility and fast shuttering times, MAXIMO opens up new possibilities of fashioning visible concrete surfaces through a particular arrangement of individual elements. The uniform tie arrangement continues to underline the very achievable results even more.



Figure 3.4 PERI MAXIMO Panel

As shown in the following picture, through the defined arrangement of the individual elements, the required visible concrete surfaces are produced. The uniform arrangement of the tie points, which are positioned throughout in the center of the panels, underline the achievable results even more.

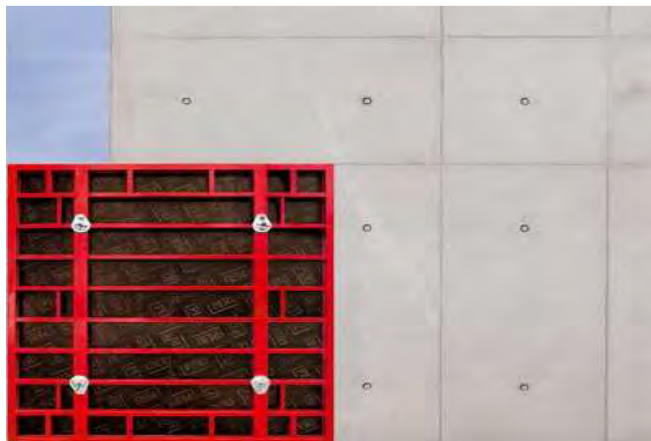

Figure 3.5 Uniform arrangements of MAXIMO tie points

MAXIMO panels are available in various sizes starting from 60 cm (height) and 30 cm (width) increasing by 30 cm in both dimensions till 270 cm (height) and 240cm (width).The two lower edges of the frames are chamfered for levering purpose.

MAXIMO panels are relatively recent innovation made to reduce labor requirement by half. Since labor cost in Ethiopia is not as expensive as in developed country, Germany, it is better

to opt for other wall formwork systems which are relatively cheaper and satisfy quality, safety and environmental requirements.

3.3.2 TRIO Panel

PERI TRIO panel formwork is a universal and versatile formwork system, and with its 2.70 m and 3.30 m system heights, as well as a sensible range of widths, can be used on small and large construction sites. PERI TRIO requires only 6 different panel widths. With clearly arranged and practical increments in panel size of 30 cm along with one 72 cm wide panel, on-site material requirements are reduced whilst utilization rates increase. The available dimensions are widths are 2.4m, 1.2m, 0.9m, 0.72m, 0.6m and 0.3m.

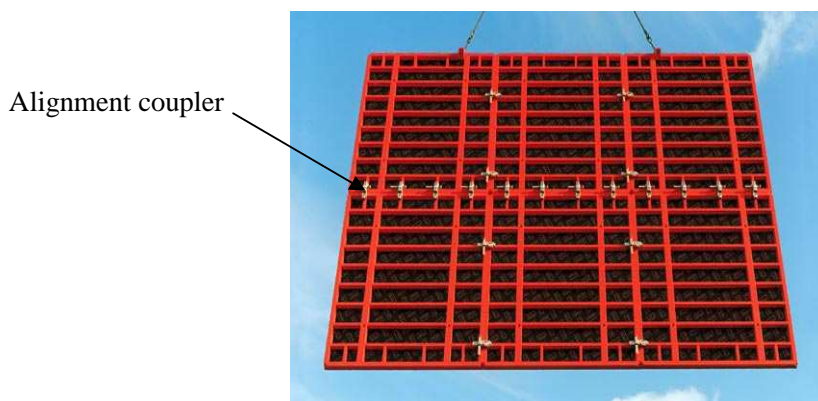

Figure 3.6 TRIO panel

TRIO and other panels are firmly connected using BFD alignment couplers. Hence the connections of the panels are simple and no part of them will be liable to damage.



Figure 3.7 Alignment coupler

There are many versions of TRIO's:

Trio -H: It is used for housing construction. The typical advantages of this formwork are:

- Extremely short form working times as:
 - All formwork activities, such as element connections, crane lifts and ties are carried out on the ground.
 - Only one tie is required up to 3.00 m concreting height (2.70 m² wall area per tie)
 - They are large sized elements , maximum (5.40 m wide, 2.70 m high)
 - Are securely mounted; foldable concreting platforms with integrated guardrails and access ladder.
- High grade surface quality as:
 - Only one tie required up to 3.00 m concreting height.
 - Large-sized elements for an architectural concrete finish which is ready for wallpapering.
 - Plywood is screwed on from the rear that leaves no unsightly screw or nail impressions.

TRIO-L Alu: Due to the low weight of its individual components, it is the ideal formwork to complement TRIO steel if working without a crane is necessary. This panel is fully compatible with steel TRIO hence all accessories for the former can be used for the later too.

Trio panels have many applications in the construction industry of Ethiopia. It can be used to produce quality concrete surfaces. It is also safe to work with such system as the adjacent panels are firmly joined using the alignment coupler. Moreover, it is relatively labor intensive as compared to Maximo or other wall formwork systems. Hence it is suitable for most of the construction projects in Ethiopia.

3.3.3 DOMINO Panel

It is a lightweight panelized formwork system with elements made of steel or aluminum for housing and civil engineering projects. It is specially developed for shuttering cellar walls up

to 2.50m high, foundations and shafts. DOMINO has four panel widths: 1m, 0,75m, 0.50m & 0.25m. These panels have high Permissible fresh concrete pressure. DOMINO elements are also extremely suitable for forming foundations. The 1.25 m high panels with inset tie points have proven to be particularly beneficial.

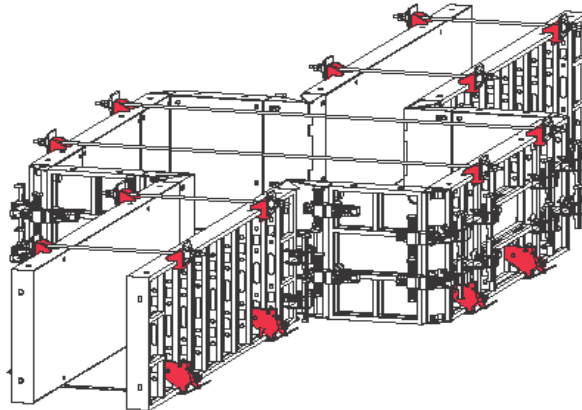

Figure 3.8 DOMINO panel as foundation shuttering

DOMINO panel are ideal for footing pad and strip foundation formworks in Ethiopia. But as the foundation works are concealed from view, traditional formwork systems are sufficient provided that they are designed well.

3.3.4 RUNDFLEX Circular Formwork

Many different curvatures are required in the construction of sewage treatment plants, access ramps for multi-story car parks, silos and other circular structures. The traditional construction is characterized by the low amount of use per formwork element. This means that assembly, modifications or re-assembly involve a lot of material and labor costs. PERI RUNDFLEX solves this problem with standard components which are also rentable. PERI RUNDFLEX is a formwork system whose elements can be continuously adjusted to form any radius beginning with an internal wall radius of 1.00 m. Radii adjustment basically begins on the spindles in the center of the element and then continued evenly outwards. Checking of the required curvature is carried out by placing the radius template on the formwork girders. The adjustment needs two personnel, see picture below.



Figure 3.9 Adjustment of RUNDIFLEX

3.3.5 HANDSET Formwork

It is a formwork system specially developed for work on a small scale, and cuts the high costs of shuttering with the old system of timbers, boards and nails. Few panel sizes ensure a high level for utilization for each element. All components are light enough to be handled by just one person. The HANDSET clip connects all elements and fixes the accessories. Whether inserted from the right or left, the clip will always resist vibration as it can be clamped downwards in both cases.



Figure 3.10 HANDSET wall formwork and its clip

HANDSET formworks are designed to be handled by fewer workmen and relatively more expensive than Trio panels. Therefore such formworks are not suitable for most construction projects in Ethiopia.

3.3.6 VARIO GT24 Girder Formwork

It is the wall formwork with continuously adjustable element connections for all designs and applications. Regardless whether it is industrial or housing construction, bridge abutments or retaining walls, any ground plan and all heights can be formed using PERI VARIO. Using VARIO GT 24 as project formwork, elements are optimized accordingly. Hence the following points can be freely selected:

- type and size of plywood as well as the fixings
- element widths and heights
- vertical or horizontal tie arrangement
- permissible fresh concrete pressure

The formwork is extended by means of the VARIO extension splice 24 in 30 cm increments up to a maximum of 8.10m quickly and easily fitted through the latticework of the GT 24, without having to drill the girders.

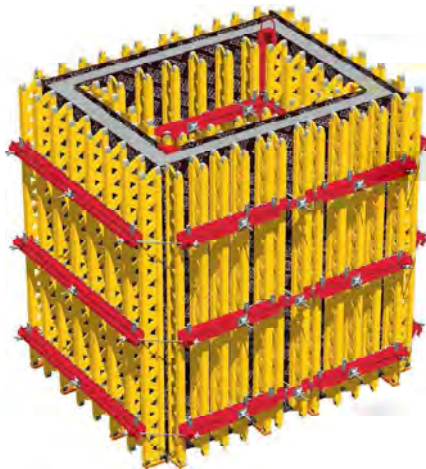

Figure 3.11 PERI VARIO wall formwork

Transferring the technology of PERI formworks especially VARIO formworks is crucial for our industry as it is possible to produce from local materials and versatile system. Timber can be cultivated for girders and metal walers can be manufactured from recycled metal by local industries.

3.4 Column Formwork

3.4.1 RAPID Formwork

Perfect concrete surfaces can be achieved using RAPID column formwork. Through the unique, patented clamping principle, the plywood is simply clamped to the frame. This results in high quality concrete surfaces without any unsightly nail or screw indentations. The chamfer strips effectively seal the corner areas. Using the RAPID system, rectangular or square column cross-sections up to 60 x 60 cm can be continuously constructed without requiring any additional anchors in the concrete. Columns with sharp edges are also possible.



Figure 3.12 PERI RAPID clamping principle

RAPID form works has the following advantages:

- *Fast assembly:* The plywood is cut to size and clamped between clamping profiles. Screws and nails are things of the past. The three frame heights of 3.00 m, 2.10 m and 60 cm provide ideal height adjustments.
- *Crane-free basic assembly:* The lightweight aluminum elements allow basic assembly to be done manually.
- *Strong frame construction:* The robust, practical closed construction of the column frames allows the PERI RAPID column formwork to withstand rough handling. The ECC powder coating guarantees that cleaning is kept to a minimum.
- *High fresh concrete pressure:* The RAPID column has been designed for a very high fresh concrete pressure of 120kN/m², which allows fast concreting. The usually very high pouring speeds for columns can easily be withstood.

For the purpose of safety, ladder access and aluminum concreting platform is delivered to the site ready for use.



Figure 3.13, RAPID column formwork with ladder and concreting platform.

Rapid column formworks are ideal system for concrete column construction in Ethiopia for safety and quality of the work. But cost wise its initial investment is too high as all sheets are made of aluminum. Hence it might have applications for limited projects in developing country.

3.4.2 QUATTRO Formwork

PERI QUATTRO columns can be moved as complete units i.e. four column elements together. Lifting the column form together with its push-pull props and concreting platform saves the site an enormous amount of crane time. Column cross-sections from 20 x 20 cm up to 60 x 60 cm can be concreted in 5 cm increments, square shaped or rectangular. It is has been designed for a fresh concrete pressure of 80kN/m². Numerous combinations are achieved by connecting just three different panel heights (0.50, 1.25 and 2.75 m) with the eye bolts, which can also be used as lifting points.

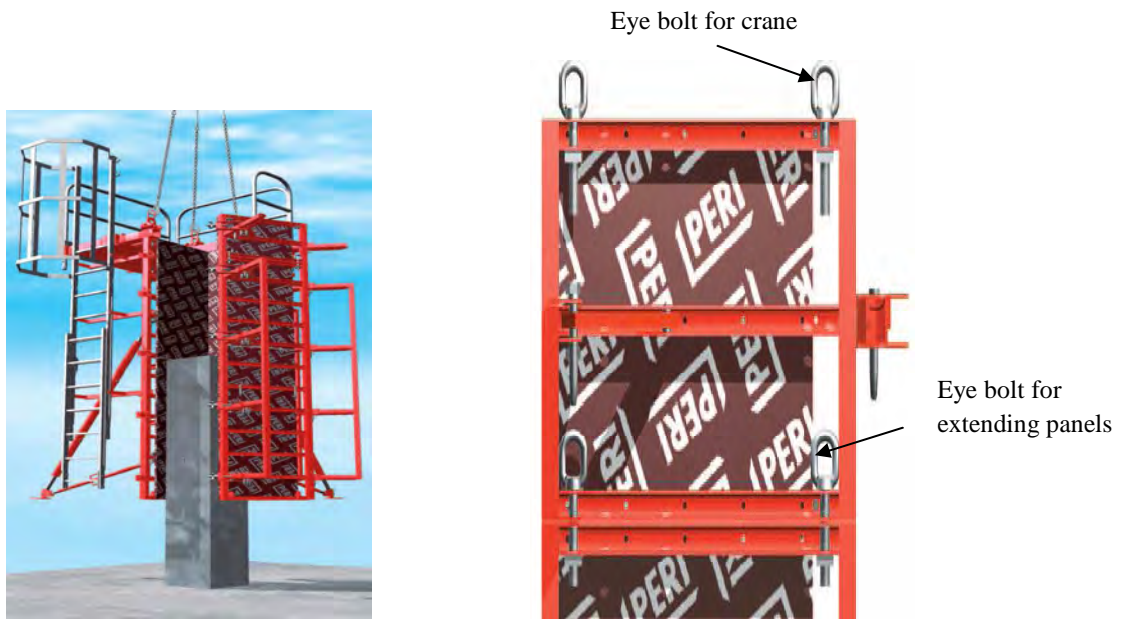

Figure 3.14 Complete PERI QUATTRO unit with its eye bolts

Through the use of transportation wheels, the PERI QUATTRO column formwork becomes even more cost-effective. Formwork crews are thus in a position to carry out shuttering and striking manually and without requiring a crane. Complete formwork units can also be moved from column to column by hand.

Quattro formwork systems are environmentally friendly as push pull props are steel as opposed to Ethiopian case where all props are made of timber. Quality of concrete surface is also much better. The requirements for plastering may decrease if such formworks are used. Hence cost for plastering work will be saved.

3.4.3 SRS Steel Circular Formwork

Manufactured according to the highest quality standards, the SRS circular column formwork guarantees a perfect concrete surface finish. It is designed for a fresh concrete pressure of 150KN/m^2 for fast and efficient concreting. The column diameters exist in 50mm increments from 250 to 700mm. The elements are extended and connected with eyebolts. The formwork is

easy to assemble; a hammer is all that is needed, the bolts also serve as the lifting point for cranes. The advantages of this column formwork are:

- *Fast assembly:* Only two column halves with integrated column bolt. The captive column bolts have self-cleaning hexagonal threads and are mounted to the column formwork halves.
- *Practical extension process:* The PERI SRS circular column formwork has four element heights (3.00 m, 2.40 m, 1.20 m and 30 cm) which allows shuttering in 30 cm increments see figure below.

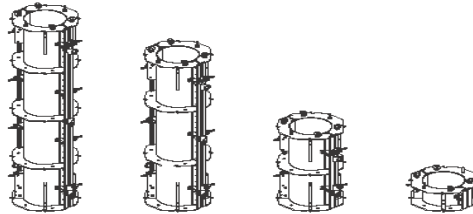

Figure 3.15 the four elements of PERI SRS

- *Easy and simple element stacking:* Integrated stacking aids ensure that the column elements are safely stacked and cannot slip. Costly site storage space can therefore be more efficiently utilized.



Figure 3.16; Lifting eyes and stacking aids on the column elements

Circular steel elements are available in Addis Ababa but the quality of the formwork is not good. Since handling, storing and cleaning of the forms are not properly done, the quality and

durability of the forms decreases. Existing circular steel formwork systems in Addis Ababa can be used if they are provided with eye bolts and proper cleaning method is used.

3.5 Slab Formworks

3.5.1 SKYDECK Aluminum Formwork

It consists of aluminum panels and main beams to make them very light .No part weighs more than 15kg.This enables easy and tireless erection and striking. With the SKYDECK drop head system, striking can be carried out after only one day (depending on the slab thickness and strength of the concrete). The drop head is released with a hammer blow which causes the formwork to drop 60 mm (panels and main beams). The panels can be separated easily from the concrete and immediately used for the next cycle. The props with the drop head and the cover strip remain; the panel and the main beam can be used for the next cycle. Furthermore, on-site material requirements are reduced. The SKYDECK main beam reduces the number of props needed. Only one prop is required per slab area of 3.45 m² for thicknesses up to 40 cm. This saves time and simplifies the transportation of formwork materials across the site. Moreover materials will be store under the spaces created by the props (figure 3.18). Such type of formwork is generally the most cost-effective where labor is expensive as an industrialized countries.

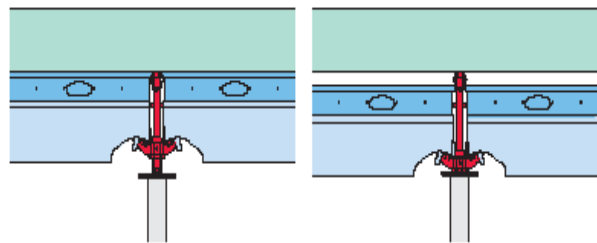

Figure 3.17 large prop spacing (left) and erection and lowering of drop head (right)

Since Skydeck formwork system is very expensive as compared to other systems, it has applications for special projects which are intended to be completed in very short period of time. Projects which give emphasis for time than cost can use such formwork systems.

3.5.2 GRID FLEX Aluminum Formwork

PERI GRIDFLEX is the flexible slab formwork system complete with accessible girder grids. Due to the lightweight aluminum components and pre-determined assembly sequence, very short shuttering times are achieved. Telescopic filler elements ensure maximum flexibility. The panel grid system allows safe access for laying the free choice of form lining. This formwork system has the following advantages:

- *Safe assembly at all times:* With the systematic assembly sequence, elements are simply hooked in at one end from below and swiveled upwards at the other by means of shuttering aid. Subsequently the slab prop complete with prop head is attached to the element and positioned vertically. The girder grid design of the GRIDFLEX automatically forms an accessible working area which provides a high level of safety when laying the plywood sheets.

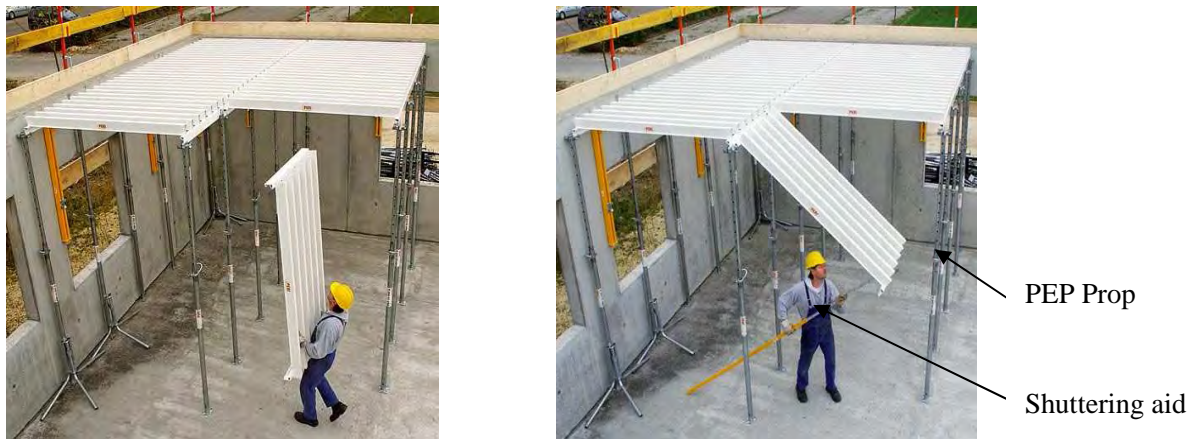

Figure 3.18 Erection of GRIDFLEX

- *Only Three Main Components are required:* The standard field is formed using only three system parts: elements, plywood and prop. The easy to handle parts and an element weight of approximately 10 kg/m² simplify the forming process.
- *Flexibility:* With the GRIDFLEX, simple labor saving filler areas can be realized for any building shape. The telescopic function provides a flexible two-dimensional adaptability in both transverse and longitudinal directions with the elements. The third dimension is aligned via the props. Thus the GRIDFLEX is, in effect, a real 3D element slab formwork system, for slab thicknesses up to 67 cm.
- *Free choice of plywood sheeting:* GRIDFLEX provides flexibility regarding the choice of form lining, depending on the project requirements.

Even though gridflex satisfies the requirements of quality, safety and environment, it has less application for most of the projects in Ethiopia as its initial investment is too high. But it might have applications for special projects.

3.5.3 MULTIFLEX Girder Formwork

PERI MULTIFLEX is flexible and versatile. It can be used for any slab thickness, floor plan and all heights. With this system, only the statically required components and the associated weight have to be moved. The GT 24 girder allows large spans and thus reduces the number of components required. The high load-bearing capacity increases the cost-effectiveness. The VT 20K girder can be used for smaller slab thicknesses. It is the most economical solution for supporting thinner slabs. With PERI MULTIPROPS, the high permissible GT 24 support reaction of 28kN can also be used with maximum extension lengths.



Figure 3.19 PERI MULTIFLEX

MULTIFLEX girder slab keeps the cost of materials down. It is therefore particularly cost effective where labor is relatively cheap. Such system can be adapted to Ethiopian construction industry as labor cost is cheap. It is a system which satisfies all the requirements of formwork construction for developing country. Besides its less material cost the construction technique is also simple which makes the system preferable.

3.5.4 PERI Slab Tables

For projects with a large number of similar applications and open facades, slab tables are the right solution. There are two types of slab tables which are produced by PERI: Module VT and UNIPORTAL, the customized slab table. Given crane capacity, slab tables are the most cost-effective solution where there is a high degree of repetition.

3.5.4a PERI Table Module VT

As rentable standard material, PERI modular tables are pre-assembled and ready for immediate use. Fall protection on cantilevered slab edges is already mounted on to the table. Especially for projects with a small number of applications, using modular tables is very cost-effective. There are four standard sizes which allow optimal adjustment to the building:

- ✓ Table Module VT 200/215 x 400
- ✓ Table Module VT 250/265 x 400

- ✓ Table Module VT 200/215 x 500
- ✓ Table Module VT 250/265 x 500

With a low stacking height of 43 cm and widths of 2.15 m and 2.65 m, the modular tables are extremely compact to transport and store.



Figure 3.20 PERI Table Module VT

3.5.5 SKYTABLE Slab Formwork

The SKYTABLE can be used for the complete width of the building. It can be assembled up to a size of 24.4 m x 6.10 m. That means large units of up to 150 m² can be assembled and moved with a single crane lift. In doing so the SKYTABLE is connected to the trusses. With one crane lift, using a special chain block system, the SKYTABLE is pulled carefully and effortlessly out of the building hence the moving process is safe. During the entire moving process, workers do not have to stand on the SKYTABLE itself. A quick release device is mounted to each MULTIPROP slab prop. Through a simple lever movement, the SKYTABLE can be effortlessly detached from the slab and lowered by approximately 2 cm. The following picture shows the SKYTABLE with truss.



Figure 3.21 PERI SKYTABLE

Local contractors who have cranes with higher capacity can use such construction system. Such system also needs sufficient space for maneuvering of cranes. Hence the availability of working spaces should be considered while selecting skytable formwork systems.

3.6 Beam Formwork

3.6.1 UZ Beam Formwork

It is continuously adjustable to suit the beam cross-section. No formwork ties are needed for beams up to 800 mm deep. Moreover the UZ width adjustment bars and UZ perforated rails can be connected together for wide beams. The main advantage of UZ beam formwork is that only two system components are necessary and beam cross-sections are continuously formed by means of these parts: UZ Beam Bracket 40 and UZ perforated rail see the following picture. The rigid connection with the UZ perforated rail allows larger spacings.

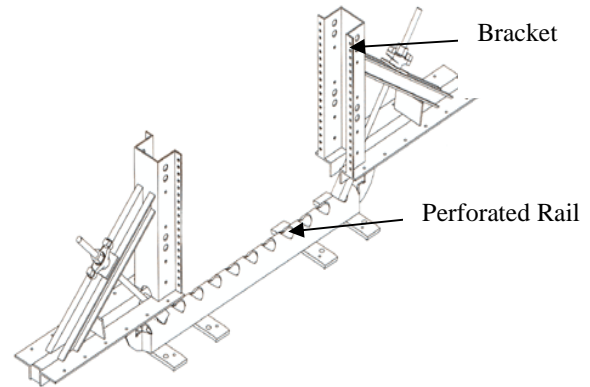

Figure 3.22 UZ beam formwork with its bracket and perforated rail

UZ beam waler can be best used in construction industry of Ethiopia. This formwork system resists concrete pressure and no bulging of beams occurs, which is recurrent problem in beam construction in Ethiopia.

3.7 Climbing Systems

PERI has many versions of climbing systems: CB climbing systems, RCS Rail Climbing Systems and ACS Self climbing systems. Special formwork systems have many applications in construction of high concrete walls (water reservoirs, dams, high rise buildings etc) which are planned to be constructed in our country. It is safe construction system for workmen and third party.

3.7.1 CB Climbing Systems

The CB 240 and CB 160 climbing scaffold systems are framework brackets for supporting large area wall formwork. They guarantee simple handling, fast concreting cycles and problem free adjustment to different wall configurations. The high bearing capacity of the brackets allows large bracket spacings (and thus large scaffold units) whilst at the same time ensuring very high load assumptions. The climbing formwork is formed by connecting the formwork and climbing scaffold by means of strong backs which is moved as a complete unit by crane.

This means valuable time can be saved. With the CB 240 system, strong backs are connected to the brackets by means of a carriage complete with rack and adjustable brace.

The 2.40 m wide decking is positioned on the brackets and level with the carriage which means the area is free of tipping hazards. Thus working safety levels in front of the formwork as well as behind are increased. The decking can be pre-fabricated and used again on the next construction site. For the CB 160, strong backs are attached by using an adjusting unit and adjustable brace.

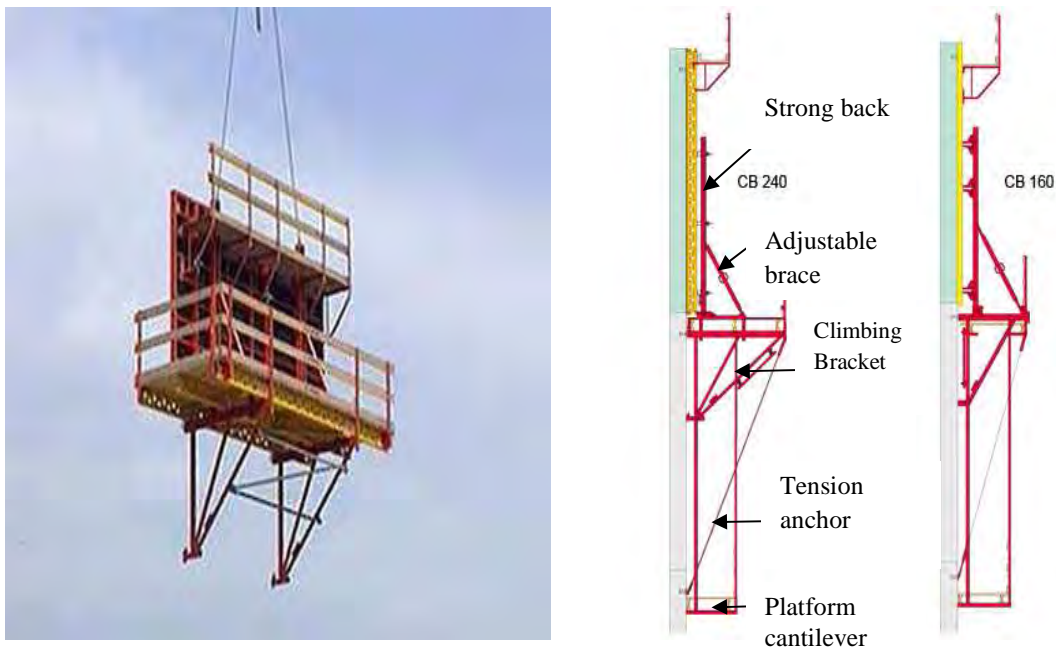

Figure 3.23 CB Climbing System

3.7.2 RCS Rail Climbing Systems

The new PERI RCS climbing system combines the advantages of various available climbing systems to form a new construction kit system. Two climbing options are available either by crane or crane independently using the mobile hydraulic climbing device. For the type of utilization, a distinction is made between the following RCS systems:

- *RCS Shuttering Scaffold*: Climbing formwork scaffolding complete with carriage for wall formwork support. It can be used for formwork scaffold, with the floor heights ranging from 2.70 to 4.50 m.
- *RCS Climbing Protection Panel*: The climbing protection panel which completely encloses floors under construction particularly on high rise structures. With the RCS climbing protection panel, the slab edges on the upper floors is completely enclosed. Site personnel are secure against falling at all times and protected against strong winds at great heights. Anchoring to the building is carried out by means of slab shoes together with climbing shoes of the system which guide the panel up the building during the climbing process. A fast and safe moving procedure is ensured through the rail-guided climbing in any weather. A further positive side effect is the advertising area available on the outer surface.

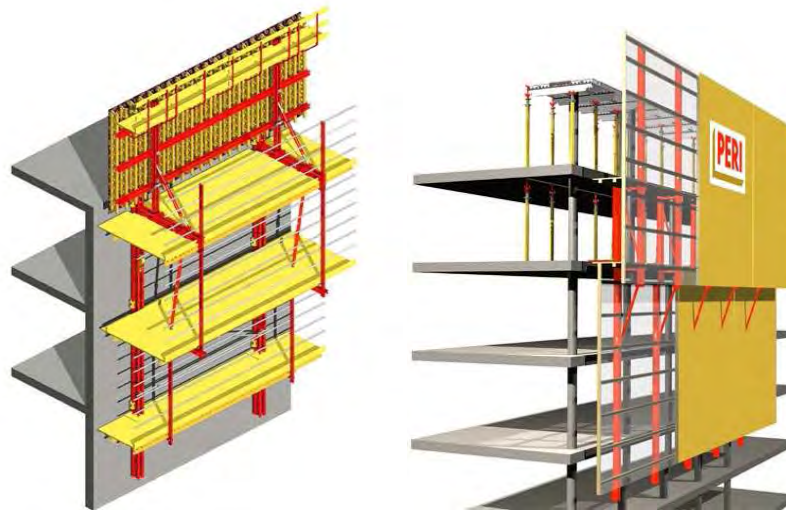

Figure 3.24 RCS shuttering and protection panels

- *Climbing Shoe RCS*: The climbing shoe RCS guides the climbing rail during the moving process to the next concreting section. For wall offsets, vertical climbing rail inclinations of up to 4° can be compensated through the hinged bearing.

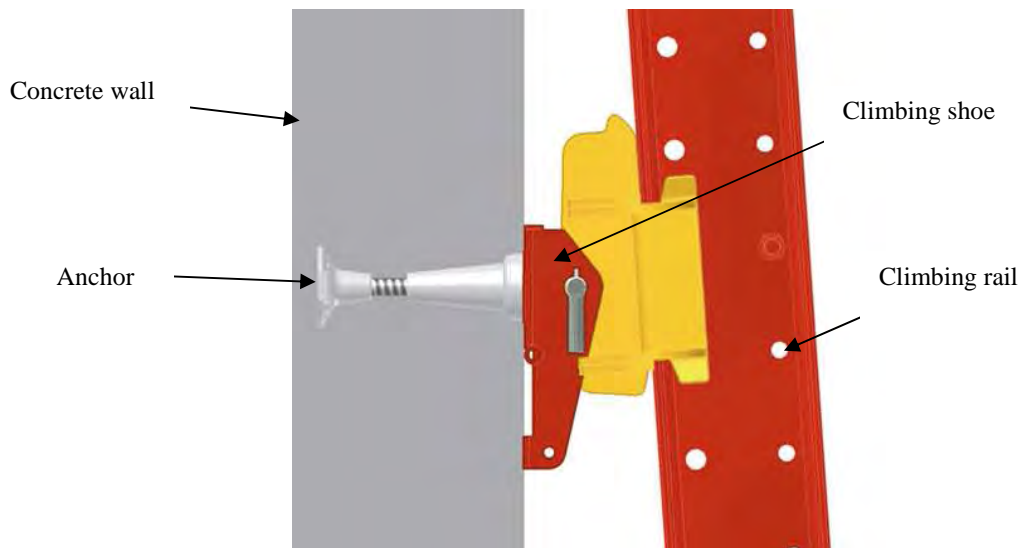

Figure 3.25 RCS Climbing rail: 4° forward angle position

3.7.3 ACS Self Climbing System

This system is crane independent climbing in all weather conditions. The ACS bracket climbs smoothly and evenly on climbing rails using hydraulic pumps. The patented ACS 100 climbing mechanism has a lifting power of 100kN and raises the unit to the next pour without the need of an intermediate anchor. Crane-independent forming, striking and climbing, accelerates work procedures on the construction site and makes them independent from each other. This allows operational speeds to be effectively maintained. PERI ACS can be climbed during all weather conditions.

Site personnel are provided with comfortable platforms which ensure safe and efficient working routines as on the ground. The working platforms can be enclosed to provide ideal protection from the weather. Working platforms can also carry high loads, For example, the storage of reinforcing steel for the next climbing lift. Even the placing boom for the concrete pump can be climbed on the ACS units, if required.

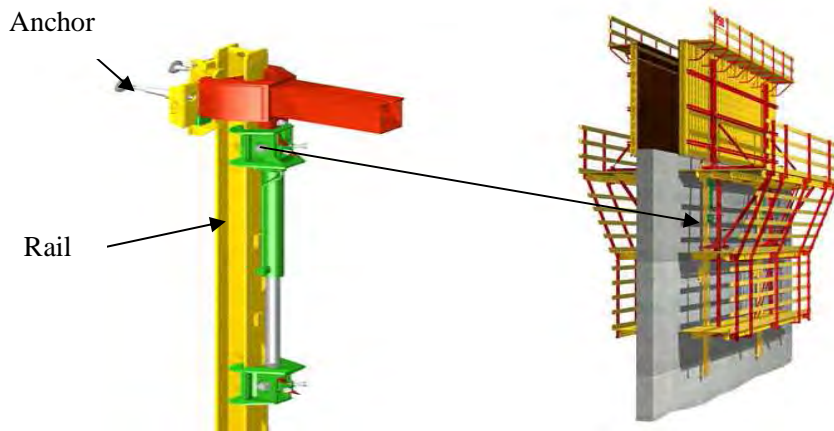

Figure 3.26 PERI ACS climbing Mechanism

3.8 Plywood Form Lining and System Independent Accessories

3.8.1 Plywood

PERI plywood has different sizes, thickness and grades to ensure the most suitable form lining for any job. There are numerous types of plywood. Fin-ply, Fin-ply Maxi, PERI Birch, PERI Spruce and FinNa-Ply are some of the products of PERI to be discussed in this chapter.

Fin-ply: This is the plywood for highest specifications. Cross-bonded birch veneers coated with 220 g/m² reinforced phenolic resin both sides, edges sealed all round. The plywood is available in thickness of: 9, 12, 15, 18, 21 mm. The approximate weight of the plywood is about 680 kg/m³. Such type of plywood is used for walls and slabs, concrete surfaces to the highest specifications, smooth and flat concrete finish. If this plywood is carefully treated it can approximately used up to 70 times.

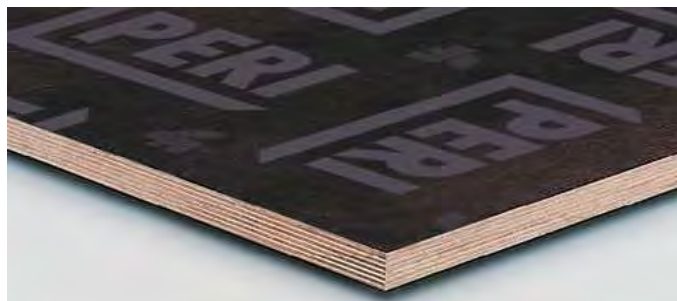

Figure 3.27 Fin-ply

Fin-ply Maxi: It is the proven fair-faced concrete plywood for high quality concrete surfaces free of joints. Fifteen cross bonded birch veneers coated with reinforced phenolic resin both sides, the face veneer with 540 g/m² and the back veneer with 220 g/m². The edges of the Fin-Ply Maxi are sealed all round with acrylic resin to reduce the absorption of water. It is applied for walls and slabs, concrete surfaces to the highest specifications to get smooth and flat concrete finish. Even though the number of times the plywood can be used depends on the conditions under which it is used and the way it is handled, PERI specified the number of use as guide for all plywood. Hence the specified number of uses for Fin-ply Maxi is between 30-70times.

PERI Spruce: It is light panel with high technical load capability. Eleven veneers of softwood plywood (21mm) with edges sealed all round, coated both sides with 120 g/m² phenolic resin. It is mainly used for slab formwork and has approximate reuse of 10-25times.

FinNa-Ply: Crude and shuttering plywood for normal requirements. It is conifer plywood, smooth face on one side and sanded surface. It has thickness of 21 mm, Size of 2500 x 1250 mm, Weight 485 kg/m³ and comprises of seven veneers. FinNa-Ply is used for general purpose concrete surfaces of normal surface finish requirements.



Figure 3.28 FinNa-ply

As PERI's formwork sheeting materials are mostly plywood, regular maintenance is mandatory. However maintenance of the plywood has an effect on the appearance of the resulting concrete surfaces.

3.8.2 Peridrain Fabric

Peridrain-Fabric is 100% polyester drainage fabric for concrete finishes with special requirements. It is attached to the form lining and concreting is carried out as usual. Eight to ten uses of one peridian fabric is possible, if it is handled and cleaned properly. The fabric drains the water from the surface zone of the concrete to reduce the water-cement ratio. This greatly improves the resistance of the surface to chemical attack. The result is a dense, highly wear-resistant finish virtually free from bug holes and voids. This fabric is used wherever the concrete finish has to meet special requirements, for example for: Water tanks, Sewage works, Sewers, Bridges, Dams, etc.

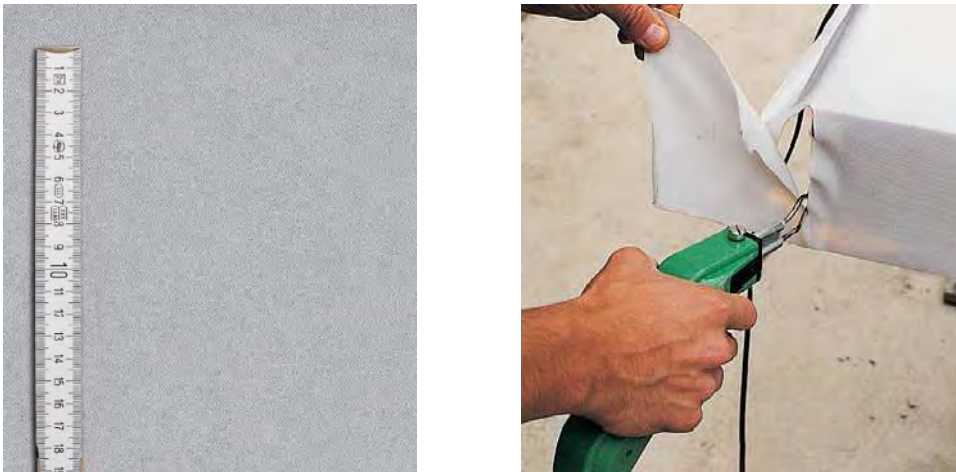

Figure 3.29 Peridrain Fabric

Peridrain-Fabric adheres much more strongly than normal form lining. Hence the striking time will be delayed. Depending on the concrete it therefore has to be struck within 72 hours.

The use of fabrics for infrastructure projects such as water reservoir, bridges etc and other structures in Ethiopia is essential for the sake of durability. Other fabrics than PERI's can be used to line the current formwork systems in Addis Ababa in particular or country in general to improve the long term properties of concrete. Therefore our contractors are advised to use such linings.

3.8.3 PERI BIO Clean

PERI Clean is liquid, chemically and physically effective concrete release agents for all commercially available formworks and construction equipment. The release effect through:

Chemical: Additives that react with the alkaline components of concrete.

Physical: Reduction of the interfacial tension between the formwork and the concrete surfaces.

That is, it has water repellent effect. It can be used for both absorbent as well as non-absorbent formwork linings. The Creeping oil characteristics regenerate resinous formwork surfaces.

PERI bio clean protects timber parts from rotting, fungus etc. and prevents rust on construction plant and machinery. It can also make threads on props and spindles easily movable. Depending on the porosity of formworks one liter of Bio clean is applied for approximately 50 to 90m² of formwork area.

Application:

- ✓ Spray the sides of the units in the stack before the first use.
- ✓ Spray the reverse side of the formwork after the first erection and repeat about every 4 weeks.
- ✓ Spray immediately after striking because Bio Clean loosens adhesive concrete and thus reduces the cleaning work.

Cleaning of formworks using Bio clean or other chemicals are essential to maintain their function and make them durable. Hence cleaning mechanisms which PERI and other international firms are using should be adapted to Ethiopia too.

CHAPTER FOUR

ANALYSIS AND DISCUSSION

4.1 General

As described in the methodology part, the approaches adopted in this research were the use of questionnaires, interviews, desk study and observations. Desk study was conducted in Germany. PERI's formwork elements and their construction methods were thoroughly studied from company's handbooks, brochures and DVDs. Moreover, formwork elements were observed on construction sites while assembling and dismantling. Many construction sites were also investigated where PERI and other companies' formwork systems were used. The results show that the system is similar to that of PERI. Therefore, PERI was taken as case study to represent international modern formwork producing companies for the purpose of this research.

Construction sites were observed in Addis Ababa to assess the quality of concrete structures casted using traditional formworks and to supplement the questionnaires distributed to contractors. Since the construction practice in other parts of Ethiopia is similar, observations were made in Addis Ababa to represent the cases in Ethiopia. Interview was made in Germany among professionals to assess the formwork hiring mechanisms. Formwork renting individuals and companies were interviewed to assess the renting system in Ethiopia.

Questionnaires were distributed to twenty-five contractors of grade one to six to assess issues such as formwork materials, costs, safety, environment, design and specifications. A total nineteen questionnaires were returned and the response rate is about 71 % (table 4.1). The detail of the survey questions are attached as appendix to this thesis. Finally, discussion and analysis on the results obtained through the above methods will be made in subsequent sections of this chapter.

Table 4.1 Questionnaires Response Rate

Respondents	Questionnaires distributed	Questionnaires Returned	Return Rate
Grade 1 Contractors	11	10	90.91%
Grade 2 Contractors	2	-	0%
Grade 3 Contractors	5	4	80%
Grade 4 Contractors	3	2	66.67%
Grade 5 Contractors	3	1	33.33%
Grade 6 Contractors	3	2	66.67%
Total	27	19	70.37%

4.2 Formwork Materials and Costs in Addis Ababa

According to the survey made in Addis Ababa, 100% of the respondents use steel panels and timber boards as formwork materials. These materials are used for casting concrete of almost all structural members such as footing pad, column, beam, slab and wall. About 79% of the respondents use plywood, 16% use precast concrete and wood particle boards and 11% use hardboard as formwork material. The summary of the results is shown in the following diagram.

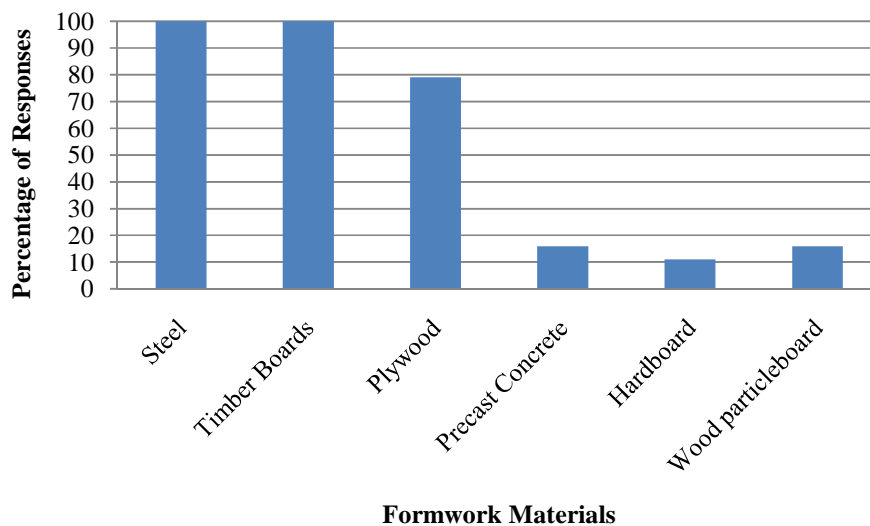

Figure 4.1 Formwork Materials Used by Contractors in Ethiopia

Alternative formwork materials such as plastic, cardboards, aluminum, glass reinforced plastic and fabric are not practiced in the construction industry of Ethiopia. Eventhough all contactors use both Steel panels and timber boards, the former are relatively more used than the later. Despite its high rate of use, the quality of the steel panels used by local contractors is not satisfactory. The panels are not maintained well and the concrete surfaces casted using such formworks are not good. From the survey made, steel panels are used a number of times without caring for its maintenance and cleaning. No concrete release agents are used during cleaning of steel panels. Most of the contractors clean the panels after the concrete was set on them. Cleaning method is done by adding water on set concrete and using sharp metals to release it. Such cleaning procedure affects the quality of panels and subsequently quality of concrete surfaces. Improper storage of steel panels has also resulted in bending and rusting of the elements.

Concerning the reusability of steel formworks in Ethiopian construction industry, 47 % of respondents use steel panels for many times, 32 % for 10-20times and 21% do not have data on the reusability. Plywood is used on average for about four times and timber boards on average for about six times. The qualities of concrete surfaces decrease as the number of uses of timber boards and plywood increase. This is mainly attributed to absorption of moisture by timber formwork from wet concrete. After stripping of the formwork, the moisture absorbed by timber will be lost to the external environment and make it shrink. Application of fabric or similar form lining will increase the number of reuses of timber formwork and local contractors are recommended to use such materials.

The source of the formwork materials in Ethiopia is through owning (purchase from both local and international markets), rental and production by the firm itself. The result of the survey is depicted in figure 4.2. All contactors purchase formworks from local market. This is mainly due to lack of adequate awareness on the modern formwork systems, which are internationally used. Moreover, shortage of foreign currency may limit the contractors to local markets only. However higher grade contractors import formwork from international markets. Plywood and

steel panels are mainly imported by contractors and only 10% of the respondents import the modern formwork elements such as formwork girders, steel props and plywood, which are used as slab formwork components. This shows that if higher grade contractors are supported by government, they have the capacity and interest to use modern formwork systems.

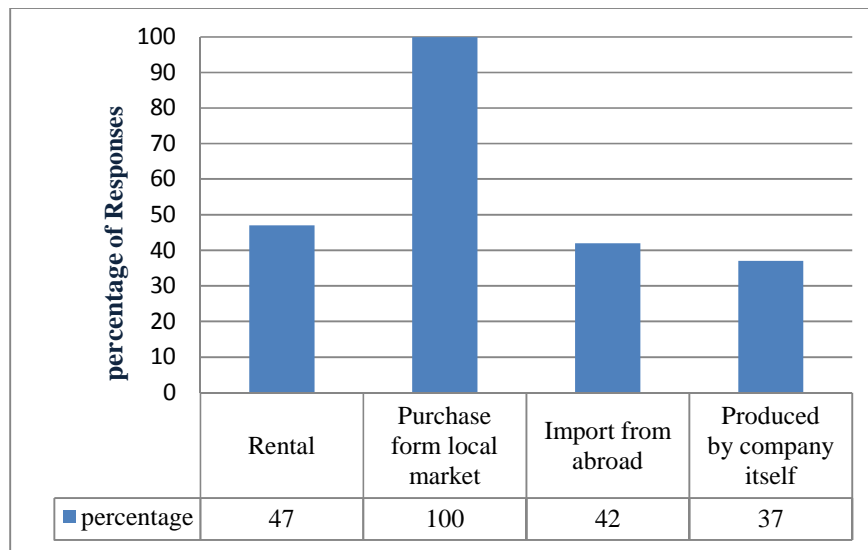

Figure 4.2 Sources of Local Formworks

About 47% of the respondents use rental formwork which is mainly steel panels. These contractors are of lower grade which are in category of grade 4 to 6. Higher grade contractors rarely use rental formwork. They have their own formwork elements. This is due to the relatively higher financial capacity of grade one to three contractors.

The average current cost of 2mm thick steel panels at local market is between 450 to 500 birr per square meter. The costs of timber boards vary between 100 to 200 Birr per square meter. Contractors offer relatively higher unit price while using timber than steel formwork due to the fact that steel has high reusability. Therefore, the cost per use for steel will be less even though its initial cost is relatively high. Similar logic applies to modern and standard

formworks. Their initial investment is high but the life cycle cost is less. They need less maintenance and once purchased less cost is incurred during the lifetime of such formworks.

The current average direct unit price for steel when used as slab and column formwork is 81Birr/m² and 79Birr/m² respectively. For timber, its direct cost when used as slab and column formworks is 113Birr/m² and 112Birr/m² respectively. The proportion of the cost of formwork for C-25 concrete casted in Addis Ababa is shown in figure 4.3. The average cost for steel and timber formworks were used in the computation of the proportions. Accordingly, the material cost for slab will be 61Birr/m² and labor cost for slab will be 28Birr/m². Moreover solid slab having depth of 15cm was assumed. The current average direct costs for in-situ concrete were surveyed as 1418Br/m³, 114Br/m³ and 123Br/m³ for materials, labor and equipments respectively.

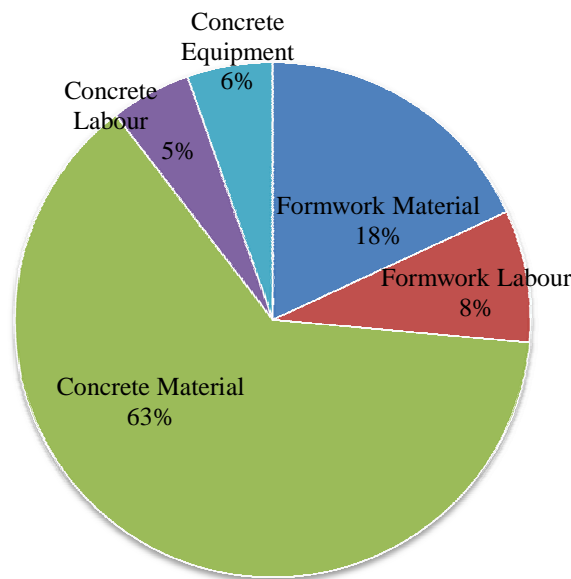

Figure 4.3 Distribution of costs for cast-in-place concrete for slab construction in Addis Ababa

As opposed to German experience, concrete material has the major cost share in Ethiopia. The formwork costs about twenty six percent of the cost of in-situ concrete, concrete labor and

material cost comprises about 11% of the total cost in the construction industry of Ethiopia. Concrete material is the major cost component in construction projects in Ethiopia but the trend in developed country is that the formwork labor cost is relatively higher. It is clear that besides workmanship and concrete mix, formworks have an effect on final quality of concrete. Hence, the use of safe and quality formwork system is mandatory so as to produce concrete with better surface quality, strength and durability.

Through the use of modern formworks the cost of plastering and chiseling of concrete, which is traditionally done to rectify construction faults in most construction projects, will be minimized and in some cases avoided. The purchase price or rental rate of the modern formwork systems can be decreased by the amount of saving from not applying plastering to concrete surfaces. For instance, the cost per square meter of PERI multi flex is about 100euros and the average current cost for two coats of plastering is about 82 birr per square meter. Cost saving of about 5euros will be obtained from using such modern system as plastering is avoided. Consequently, the new price of PERI multiflex will cost 95euros per square meter. Similar reduction in costs, though it is not significant, for beam, column and wall formworks will be obtained provided that contractors use modern systems. There are other international companies, which offer formwork systems at lesser price than PERI, and local contractors can get alternative modern formworks at lower price than stated above.

4.3 Formwork Construction Practices in Ethiopia

Survey was made to assess the practice of formwork construction systems such as climbing, flying, tunnel and gang systems. From the result it is concluded that such systems are new to the construction industry of Ethiopia. Some contractors have planned to use such systems in the future. All contractors follow the conventional wood, timber and combination of metal and timber construction systems.

According to the survey conducted 32% of contractors use labor only in transporting, erecting and stripping of formworks. Of those contractors 50% of them are less than grade 3 and 50%

are grade three contractors. About 42% of the total contractors use crane and labor and 26% use labor and hoists for the construction and dismantling of formworks, see fig 4.4. The result indicates that all contractors in the category of one to three use cranes in formwork construction. Hence, such contractors will face no problem in handling and transporting of modern formwork systems, which is relatively heavy to handle using labor only. No additional cost incurs for transportation of the new formwork systems.

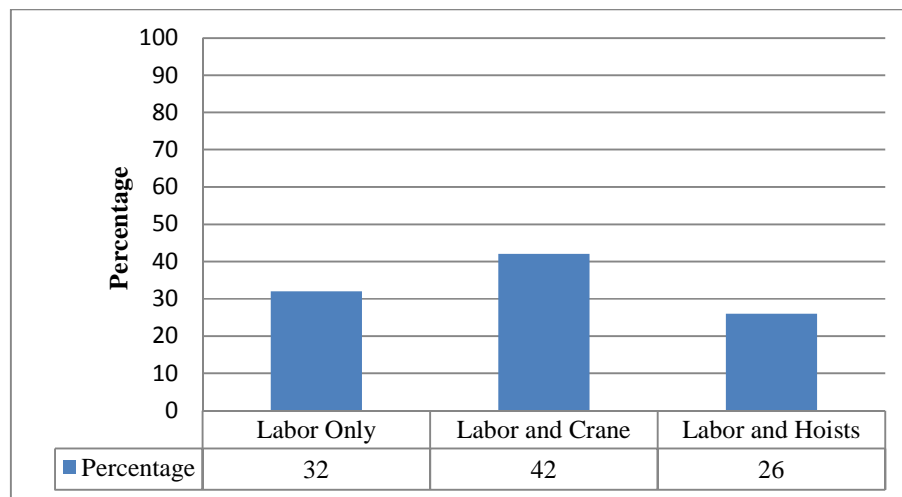

Figure 4.4; Transportation of Formworks in Addis Ababa

Productivity data for formwork construction is not well-recorded by Ethiopian contractors. From the assessment made some of the contractors do not have the data for erecting and stripping of formworks even if they worked for many years on different projects. Some of them offer data, which is ideal to achieve using traditional construction system. Majority of the respondents, 63%, offer similar data for productivity of formwork construction and the average result is presented in the following table.

Table 4.2 Productivity of Formwork Construction in Addis Ababa

Formwork systems	Member							
	Column		Beam		Slab		Wall	
	Erecting (m ² /hr)	Stripping (m ² /hr)	Erecting (m ² /hr)	Stripping (m ² /hr)	Erecting (m ² /hr)	Stripping (m ² /hr)	Erecting (m ² /hr)	Stripping (m ² /hr)
Conventional wood formwork	0.80	2.81	0.58	2.43	0.68	2.73	0.85	2.88
Conventional steel formwork	1.58	3.69	1.39	3.38	1.48	3.60	1.73	3.72

As shown in the table above, choice of formwork material has an effect on the productivity. The construction of steel panel with wooden props is relatively easier than using traditional timber boards with wooden props and yokes. The use of steel props instead of wooden for any formwork sheets yields more productivity. According to the interview made, it is about four times as productive as traditional wooden props. Contractors in Ethiopia are not productive enough and one of the methods to enhance their productivity is to replace the traditional formwork construction with modern system. The productivity of PERI formwork systems depend on type and size of elements and different productivity values can be obtained depending on the choice of elements. For comparison purpose, consider the least productivity value of about 3.76m²/hr for erecting wall formwork. When compared to local case it is about five times. The difference in productivity is up to ten times of the local one when relatively larger elements are considered.

Standardization of formwork should be made to avoid or minimize the productivity variations in Ethiopian construction industry. If the formworks are standardized, the productivity data for erecting and stripping of formworks will be easily established for the country as well as for individual contractors. Higher variations in the unit price offered by contractors will be minimized as labor productivity has effect on cost.

The stripping time of soffit formworks for slab and beam varies from 10 to 28 days depending on cement type. Summary of the results of formwork stripping times is shown in figure below. Most contractors wait for 14days before removing soffit formworks of concrete slabs and beams casted with OPC cement. For concrete casted with PPC, minimum of 21 days are elapsed before removal of the soffit formworks. Expected stripping time using OPC cement, $E(t) = 0.11*10+0.33*14+0.17*18+0.28*21+0.11*28 = 18$ days. For PPC cement the expected stripping time, $E(t) = 0.05*14+0.05*18+0.43*21+0.42*28+0.05*45 = 25$ days.

Consultants in Ethiopia do not provide design information such as design live and dead loads to contractors. There is also no standard guideline set by regulatory body for computation of the minimum strength of concrete before stripping of formworks. According to British standards, the minimum strength to be attained before removal of soffit formwork for slab is computed below.

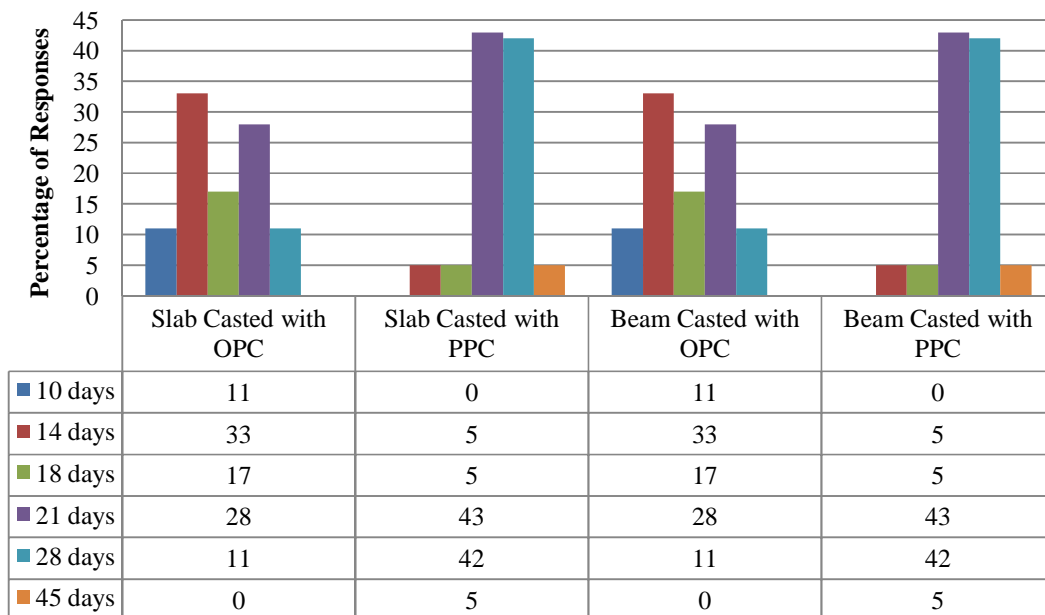

Figure 4.5 Formwork stripping times in Addis Ababa

Consider an office building to be constructed in Addis Ababa. Let the slab thickness be 15cm and design live load as per EBCS 1, 1995 is 3KN/m². Dead load for the slab is computed by assuming 2mm thick PVC, 48mm thick cement screed, 15cm thick concrete and 2cm thick ceiling plaster. Accordingly, the design dead load will be 5.35KN/m². Therefore; the total unfactored design load is 8.35KN/m². The load on the structure at the time of striking of the formwork will include the formwork self-weight, the mass of the concrete, plus construction operations load. As per British standard, the minimum self weight of formwork is taken as 0.5KN/m² and construction operation load of 0.75KN/m² is considered for calculation of the desired strength. Total unfactored loads during construction will be 5KN/m². Therefore the minimum strength to be achieved before formwork removal, f_c , will be:

$$f_c \geq f_{cu} (W/W_{ser})^{1.67} \quad \text{where } W=5\text{KN/m}^2, W_{ser}=8.35\text{KN/m}^2 \text{ and } f_{cu} =25\text{MPa}$$
$$f_c \geq 10.62\text{MPa}.$$

Therefore the minimum strength of 11MPa is required before stripping of formwork for the given office building. The time required to attain such strength can be obtained from laboratory and duration will be fixed. Refer table 4.3 and 4.4 for the test results of concrete cubes taken from construction sites in and around Addis Ababa. Tests were made to assess whether the concrete satisfies grade of C-25.

From laboratory data, the average strength of concrete casted with PPC is 11.6MPa and 22.8MPa at seventh and twenty eighth day respectively. Where as the result for OPC is 23MPa and 34MPa at seventh and twenty eighth day respectively. Since the minimum strength required for the office building with the previous assumption is 11MPa, ten to fourteen days is sufficient to strip soffit formworks supporting concrete casted with Portland Pozzolana Cements. And the waiting period of seven days is sufficient for OPC before removing of the formworks. Contractors incur the minimum delay of eleven days due to not designing the formworks and not using modern formwork systems which are easy to erect and dismantle.

Table 4.3 Test Results of Concrete Cubes Casted with PPC (Source: AAU, EiABC laboratory)

Sample	Age in days	Cement Type	Average Strength (MPa)
A	14	Muger PPC	10.1
	28	“	13.9
B	14	Muger PPC	28.4
	28	“	29.9
C	7	Mosobo PPC	17.6
	28	“	25.1
D	7	Muger PPC	12.9
	28	“	22.9
E	7	“	13.8
	28	“	21.7
F	7	“	13.3
	28	“	26.2
G	7	Mosobo PPC	11.3
	28	“	21.2
H	7	Muger PPC	16.3
	28	“	29.6
I	7	“	17.8
	28	“	25.6
J	7	Mosobo PPC	9.5
	28	“	17.4
K	7	“	7.7
	28	“	16
L	7	Muger PPC	13.3
	28	“	23.7

To justify the time to be saved in using modern systems, consider slab formwork construction of G+6 building. Say only one crew and one formwork systems are involved .The area of each floor slab is about 100m² and is to be casted with PPC. The average duration until stripping of the last floor soffit formwork using traditional construction system will be:

- Erecting time = $100\text{m}^2 / (0.68\text{m}^2/\text{hr}) = 147\text{hrs}$ which is approximately 18days.
- Stripping time= $100\text{m}^2 / (1.48\text{m}^2/\text{hr}) = 68\text{hrs}$ which is approximately 8days.
- Expected waiting time =25days
- Total duration for formwork construction process of one slab =51days.
- Total for six floors=306days

For modern formwork systems, considering the productivity as five times that of local practice

- Erecting time = $100\text{m}^2 / (3.4\text{m}^2/\text{hr}) = 30\text{hrs}$ which is approximately 4days.
- Stripping time = $100\text{m}^2 / (7.4\text{m}^2/\text{hr}) = 14\text{hrs}$ which is approximately 2days.
- Waiting time = 14days
- Total duration for formwork construction process of one slab = 20days.
- Total for six floors = 120days

From the above analysis minimum of 186 days will be saved if modern formwork systems are used. Hence formwork systems have great contribution for improving productivity and avoiding delays of projects.

Table 4.4 Test Results of Concrete Cubes Casted with OPC (Source: AAU, EiABC laboratory)

Sample	Age in days	Cement Type	Average Strength (MPa)
A	7	Pakistan OPC	17.8
	28	“	22.6
B	7	“	17.0
	28	“	26.4
C	7	“	26.1
	28	“	40.3
D	7	“	26.1
	28	“	39.3
E	7	Mosobo OPC	28.8
	28	“	42.0
F	7	Pakistan OPC	15.9
	28	“	28.9
G	7	Yemen OPC	23.7
	28	“	36.3
H	7	Pakistan OPC	32.4
	28	“	45.0
I	7	“	24.7
	28	“	28.1
J	7	“	14.5
	28	“	21.2
K	7	“	28.9
	28	“	44.4

As per the survey conducted, all contractors use cement paper bags to control the loss of mortar or cement slurry at the junction of formwork elements. This phenomenon occurs due to lack of well designed formwork. The use of sealing materials such as paper bags may not totally hinder the loss of paste and the actual in -situ strength of the concrete will be less than the strength for which the structure is designed for. Therefore, contractors should adopt new formwork systems to alleviate such problems.

All contractors do not design the formwork for the applied load and consultants provide little assistance to them. This practice is not economical and safe. Hence designing of formwork should be practiced in Ethiopian construction industry.

4.4 Safety and Environment Issues in Formwork Construction

Construction activities should not threat the environment. The use of timber props and forms without guaranteeing their replacement is one of the threats to the environment. PERI formwork systems do not use timber props and are environmentally friendly in this aspect. Even though the sheeting material of the formwork systems is timber, the supplier of the timber guarantees the replacement of trees. Therefore it is possible to say that construction using modern formwork systems is sustainable. The same situation should occur in the construction industry of Ethiopia.

It is clear that handling construction equipment is very expensive. Loading and unloading, moving and temporary storage on site can expose the workforce to various dangers. Using the latest containers and pallets rather than making do as usual cuts costs while enhancing safety. Refer the pictures below for PERI pallets and containers.



Figure 4.6 Safe Material Handling and Transportation

For the sake of safety on site; orderly storage of equipment; compact stacking; easy access and safer shifting with forklift truck and/or crane is crucial. These can be achieved through the use of modern site equipments like PERI site accessories. Safety guard rails systems and working platforms are also provided at all working levels (figure 4.7). Some formwork systems are totally enclosed to obscure workers from looking down and provide protection against wind.



Figure 4.7 Safety Guard Rails and Platform, Darmstadt

The practice of safety and environment issues during formwork construction in Ethiopia was assessed and discussed in subsequent paragraphs.

From the survey results, there is no officially published health, safety and environment for construction industry in general and formwork construction in particular by regulatory bodies in Ethiopia. Seventy nine percent of the respondents have the record of injuries or death during formwork construction. This indicates that Construction of formwork in Ethiopia is not safe. About 47% of the respondents do not provide safety clothes to their workmen at construction sites and 53% have safety clothes but do not always provide to their workmen.

Concerning the use of formwork release agent most of the contractors, 84%, use burnt oil and could not control the dosage of the release agent. Other form release agents are also used but rarely, see figure 4.8.

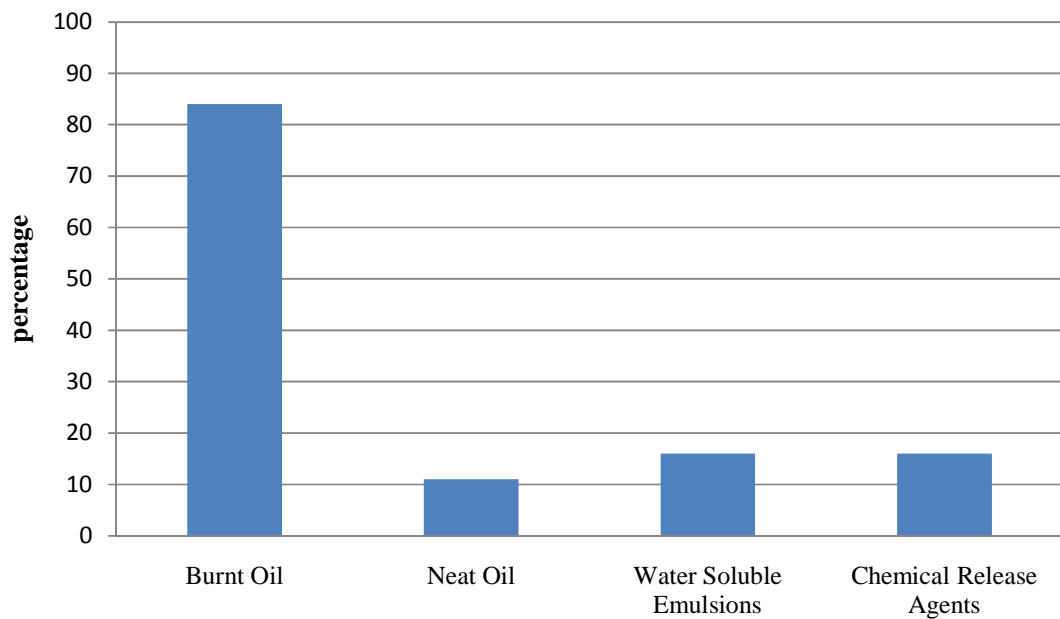

Figure 4.8 Formwork Release Agents Used in Addis Ababa

All respondents are aware of the side effects of using burnt oil but still use it as release agent. The main effects of this oil are:

- Creation of unclean environment.

- Create poor bondage between re-bar and concrete if applied excessively.
- Change the color of concrete to black and architectural concrete cannot be attained.
- Curing will not be effective if excessive oil is applied as it prevents the sprinkled water from penetration.

The construction industry is the major contributor for the deforestation of trees. Many trees have been cut to be used as formwork, scaffolding and other construction activities. For instance to cast concrete slab having area of 100m^2 and $10\text{m} \times 10\text{m} \times 0.15\text{m}$ dimension; computation for quantity of timber supports is made as follow:

- Average spacing in both sides of the props is 60cm.
- Average diameter of timber props varies from 8cm to 12cm.
- Average height of props is taken as 3.0m
- Props are reused for maximum of three times.

Accordingly, minimum of 324 props and minimum length of 540m horizontal members are required. Total length of timber is about 1512m. Assuming the length of tree as five meters, minimum of 302 trees are cut to cast concrete for 100m^2 slab. To complete slab concrete work of one G+6 building at least 604 trees are required. The quantity of trees to be cleared increases as the area of the slab increases. Moreover the deforestation rate depends on the rate of construction. It is clear that the current construction rate in Addis Ababa is high and many trees are being cleared. Therefore the current 3% coverage of forest is expected to decrease in near future if deforestation for construction and other industries continue as it is being done now.

All respondents agree on the issue of prohibiting contractors from using timber for formwork construction. Policy such as prohibiting contractors of grade 1 to 3 from using timber as formwork material should be enacted by regulatory body to reduce the deforestation contributed by construction industry. The policy will also apply to other grades of contractors gradually. As higher grade contractors are in better financial capacity, the policy can be

implemented easily. The implementation of the policy helps not only to safeguard the environment but also enhances safety and quality of the country's construction.

Eighty two percent of the contractors recommend alternative formwork materials such as steel, plastic, glass reinforced fiber and use of precast concrete instead of cast in situ. Only 18% of the respondents want to continue using timber as construction material. These are lower class contractors who argue that the initial cost of new material might be higher than the one they are using now. Therefore it is possible to say that contractors will accept policy change provided it is enacted.

In general time, safety and environmental issues discussed in previous sections are some of the factors which oblige the construction industry of Ethiopia to use modern formwork systems. Formworks are left for longer period of time before striking and delays in construction industry of Ethiopia are common. Construction safety in Addis Ababa in particular and Ethiopia in general is given less emphasis which is threat to the construction industry. Failure of formworks or associated false works is expected to occur as there is no focus on the design and construction of proper formwork systems. Concerning environment, many trees are cut without promising their replacements. The construction industry is the major contributor for the deforestation of trees.

Therefore the use of modern formwork systems is mandatory to alleviate the above problems. In an attempt to solve the problems there is no need to start from scratch, the systems which developed countries such as Germany or others followed will make things easy. Hence the modern formwork systems of PERI, Germany, are investigated from this perspective.

It is obvious that the labor cost in developed countries is much higher than that of developing countries like Ethiopia. Hence the criteria to select the formwork systems for developing country should be based on the use of both labor and equipment by the system. Currently equipment intensive formworks are not preferred in Ethiopia as there are many labors in

country in general and in Addis Ababa in particular as compared to developed country like Germany.

Traditional formworks in Ethiopia which are labor intensive need to be partly or totally replaced by modern formwork system which balances the use of both labor and machinery. Accordingly PERI products are assessed for the material and labor costs, quality of the concrete surface and durability of the product. The assessment was also made through construction site visit on top of company's document review.

4.5 Suitable Wall Formwork System for Ethiopia

This formwork system has many applications in construction industry of Ethiopia. For instance, in building projects for lift shafts and concrete walls; in other civil engineering projects for water reservoirs, retaining walls etc. As construction of such structures is booming, selection of appropriate formwork system is mandatory. Modern wall formwork systems are believed to alleviate many problems associated with current concreting practices of walls in Ethiopia. Among the problems, formation of cold joint in concrete structures and loss of plumbness of walls are the common ones. Cold joints occur as the walls are not casted monolithically and loss of plumbness is the result of bulging of formworks due to concrete pressure. Since the modern formwork systems are designed for the required concrete pressure and are available in different heights, the defects in current concreting practice do not occur. Discussions on relatively more suitable formwork systems are made in subsequent section.

TRIO Panel and VARIO GT 24 can be used to solve the problems in the construction industry of Ethiopia. Other wall formwork systems can also be used but they are equipment intensive and costly. TRIO panels are easy to assemble and labors can get job opportunity which is the main issue besides quality of concrete in Ethiopian context. If such formwork systems are used, extra cost from plastering will be avoided and the structure's level and plumbness will be as per the design. The dispute between contractor and designer or client due to defect in concrete quality will also be minimized. From the site visit made in the selected site in

Darmstadt, such wall formworks and concrete surfaces were observed. The surface of concrete wall is good in both faces. The thickness of the wall is also as per the design and no bulging occurs. It is perfectly aligned vertically and horizontally. The following picture shows the partial view of concrete basement wall casted using TRIO panels.



Figure 4.9 Concrete surface casted using TRIO panel, Darmstadt

In selection of standard wall formwork pieces, the geometry of the building or structure should be taken in to consideration. Complex design may need new formworks which are not in the standard and contractor is obliged to purchase or produce the formworks for the particular project. Consequently the cost of the project will increase. Another factor which affects the cost of formwork especially the labor cost is size. Small size panels require many joints and more labor time as compared to the larger one. Since labors are paid on hourly base, longer working time implies higher cost. Hence the labor cost for wall formwork is variable. It depends on the design and choice of elements by the contractor. In general larger formworks are preferred if the shuttering area is large. The optimum formwork elements combination is chosen by patented software developed by PERI for the desired project.

Manufacturers have their own recommendation on the shuttering and removal time of the single as well as combination of the elements with different widths. Table 4.5 shows the typical PERI wall formworks and their operation times. The time given in the table is for one person with the aid of crane. From the table it is possible to analyze the labor time for larger and smaller element. Single element with area of 0.828m^2 requires about 0.22hour and

combined element with area of 13.25m^2 requires about 1.54 hours. For the single element to shutter the same area as the larger element about 16 pieces are required and the time will be about 3.52hr. Hence it will take more time to shutter the same area. In general as the formwork size increases, the aggregate time required to shutter decreases and the number of joints between the members decrease which implies that better concrete surface will be obtained.

The labor cost computation in Germany includes many factors such as overtime, holiday, hardship supplement, bonus for permanent staff, insurance, travel allowances etc. on top of basic payment. The average wage to be paid for one person including the above factors is about 34euro per hour. So the labor cost of using smaller panels to shutter 13.25m^2 of wall is $3.52\text{hours} \times 34\text{euro per hour}$ which is about 119.68euros. For larger one the labor cost is 1.54×34 which is about 52.36euros. Therefore labor cost increment of more than hundred percent is observed between the two formwork elements. The working time for the labor can be reduced if more labors are employed. For instance the time required to shutter single element with height 2.65m and area 0.828m^2 will be reduced by half if two labors are used to erect it. Such advantages can be used in Ethiopia as the labor cost is not as much expensive as in Germany.

Table 4.5 Recommended times for shuttering and stripping of wall formworks

Formwork system	Weight (kg)	Area (m ²)	Width (mm)	Time (hr.)	
				<i>Shuttering</i>	<i>Stripping</i>
Single element with height of 2.65m	55	0.828	312.5	0.22	0.16
	81	1.656	625.0	0.31	0.20
	84	1.921	725.0	0.34	0.22
	112	2.677	1010	0.42	0.25
	140	3.313	1250	0.49	0.28
Combination of elements with height of 2.65m	168	3.975	1500	0.55	0.31
	224	5.300	2000	0.69	0.36
	280	6.625	2500	0.83	0.40
	336	7.950	3000	0.98	0.45
	392	9.275	3500	1.12	0.49

Table 4.5 Recommended times for shuttering and stripping of wall formworks Continued

Formwork system	Weight (kg)	Area (m ²)	Width (mm)	Time (hr.)	
				Shuttering	Stripping
Combination of elements with height of 2.65m	448	10.600	4000	1.26	0.54
	504	11.925	4500	1.40	0.58
	560	13.250	5000	1.54	0.62
Single element with height of 1.25m	28	0.391	312.5	0.19	0.15
	43	0.781	625	0.23	0.17
	44	0.906	725	0.24	0.18
	53	1.263	1010	0.27	0.20
	61	1.563	1250	0.30	0.21
Single element with height of 0.25m	7.7	0.156	625	0.11	0.10
	8.4	0.181	725	0.11	0.10
	9.4	0.208	830	0.12	0.10
	11.2	0.253	1010	0.12	0.10
	13	0.313	1250	0.12	0.10
	27	0.625	2500	0.21	0.17

By considering the average labor rate for skilled manpower in Addis Ababa as 12.5birr per hour, the labor cost for shuttering 13.25m² using small panels and single person will be 12.5birr per hour *3.52hours which is about 44 birr or less than 3 Euros. This indicates that the labor cost in construction industry of Ethiopia is insignificant as compared to developed country. Hence training and employing of local manpower in assembling and erecting modern formwork system is crucial for the improvement of quality of concrete. This mechanism will help in decreasing the labor cost for formwork construction locally.

The material cost of wall panels varies depending on the size of element. The average costs of some of the wall, slab, column and other accessories are summarized in table 4.6. The cost of small size TRIO panel is about 577euros per square meter. And cost for larger TRIO element

it is about 263€/m². This indicates that local contractors are benefited if they own larger elements.

4.6 Suitable Slab Formwork System for Ethiopia

Depending on the project types and availability of finance, aluminum slab formworks of PERI such as Sky deck and Grid flex can be used for construction in Ethiopia. Such formworks are very easy to handle and the labor cost is low. But the material cost is too high and usually recommended for projects which are intended to be completed in short period of time. For instance, investors who want their projects completed early can use such system. PERI MULTI flex is more suitable for the construction industry of Ethiopia. Local contractors will get the following benefits from such formwork:

- Better concrete surfaces are obtained than the conventional formwork system.
- Its Assembly is easy.
- It creates job opportunity for labor as relatively more labors participate than other formwork systems.
- It is not as costly as other formwork types.
- It is relatively easy to transfer the technology of MULTI flex. That is local material can be used for the production of girders.

Improving the competence of local labor in using such system is an important issue in construction industry of Ethiopia. One means of doing it is to train, identify and manage the factors which affect their productivity.

The labor cost for laying one square meter of MULTI flex ranges from 52.3 to 75.6euros. If the labor is productive, the cost decreases accordingly. If the technical capacity of local labor is built, the cost will be reduced in case of construction projects in Ethiopia. The material cost of MULTI flex is less than 100€/m². As shown in table 4.6 the cost of table module which is assembled by PERI is about 104€/m² and MULTI flex are assembled on site by contractor which costs less than the pre-assembled modules. Hence MULTI flex is suitable for the

construction industry of Ethiopia as it fulfills the cost, quality and safety requirements in formwork construction.

The durability of the formwork in general depends on how it is treated during construction. If proper care is not given to forms, their number of uses will decrease. Hence care during transportation, storage, assembly and stripping need to be made so that the formworks will be durable. Durability may also depend on the choice of form lining material or Ply wood. Hardwood ply wood such as Fin-ply can be used for more than 70 times and softwood ply wood such as FinNa-ply can be used on average 25 times. Therefore both plywoods can be used based on the financial capacity of the contractor. It is also possible to produce plywood locally and replace the old form lining.

Table 4.6 Material Costs of PERI products

No.	Element	Price
1	TRIO270/240 steel panel	1708euro/pc or 263.58euro/m ²
3.	TRIO270/90 Aluminum panel	808 euro/pc or 332.51euro/m ²
5	Table ModuleVT200/215*400	944euro/pc or 118euro/m ²
6	Table ModuleVT250/265*500	1302euro/pc or 104euro/m ²
7	Circular Column panel diam.25cm h=3m	264euro/pc or 111.86euro/m ²
8	TRIO column panel TRS270*90	958.50euro/pc or 394.4euro/m ²
10	VARIO panel 250*240	1026.00euro/pc or 171.0euro/m ²
11	DOMINO panel 250*100	485euro/pc or 194euro/m ²
12	Steel Prop PEP20-300	63.70euro/pc
13	PERI Girder VT 20 145cm long	9.45euro/pc
14	PERI Girder GT 24 90cm long	14.9euro/pc
15	Fin ply 21mm 1500*2500mm	22.0euro/pc
16	Peridian Fabric 2.8*25m	2110.0euro/pc

4.7 Suitable Column and Beam Formwork Systems for Ethiopia

In some construction projects in Ethiopia, many quality problems were observed on beams and columns construction which has to be rectified through the use of modern and standard formworks systems. Among the problems, the following are the major ones:

- The column cross sections are not the same at top, middle and bottom, the cross section at the bottom is larger due to the increase in the pressure of concrete on the formworks. This is attributed to the improper design and construction of formworks. The change in cross section has influence on wall to be constructed between the columns. Blocks are cut to compensate for the decrease in space at the bottom owing to bulging of columns. Therefore blocks are being wasted due to change in dimension between columns.
- Extension of column formwork is not properly done in case where it is required to cast relatively high column concrete. The lower and top cross sections of column are completely different. As there is weak joint between lower and extended formwork, the upper section is thicker than the lower. The situation is also true for beams. Chiseling of concrete surface is made to rectify such errors. Besides adding cost to contractor, over chiseling may affect the structure. Over chiseling can affect the durability of concrete as new concrete which is not well compacted is applied to the affected area. Such problems can easily be alleviated by the standardization of formworks. Moreover design of temporary works need to be submitted by contractor and approved by the competent consultant.
- In some circumstances, the cross section of beam is not uniform due to the fact that formwork tie materials and methods are inappropriate. Black wire is mostly used to tie side formworks of the beam. The wire may not sustain the concrete pressure and the beam bulges. More over the spacing and the strength of the ties need to be designed properly to avoid such problems. But most local contractors lack the practice of designing formwork ties. Not only bulging out of beams occurs but also over tying and reduction of cross-section is common. The latter is made in anticipation that the

dimension of will be adjusted after casting concrete and vibrating. This is sheer trial and error as the dimension may return through pressure or not. Therefore UZ beam formwork will solve such problems.

All the above factors enforces the contractors to look for modern formwork systems such as PERI Trio, QUATTRO and Vario which are easy to assemble and not as costly as aluminum forms. Good surface finish is obtained with these formworks. This was confirmed through construction site visits made in Germany. See figure below.



Figure 4.10; Concrete column formwork casted using PERI formwork, Darmstadt

The edges of columns can be chamfered or sharp as shown in the above figure. No cement sand plastering is required to form the edges of column and beams as it is usually done in the traditional construction in Ethiopia. With regard to labor productivity for column formwork; it is between $0.9\text{m}^2/\text{hr}$ and $1.4\text{m}^2/\text{hr}$. For beams it is between $0.9\text{m}^2/\text{hr}$ and $1.3\text{m}^2/\text{hr}$. The approximate labor costs per square meter for columns and beams are 30.6-47.6euros and 30.6-44.2euros respectively.

Staircase formworks were assessed but the trend in Germany or other developed country is to use precast elements for such members. This is done because the construction of stairs takes

much time and need precision. Steel formwork elements are used in case where stairs are casted on site.

4.8 Special Formworks for Developing Country

For special projects such as high rise buildings and other civil structures with high walls, PERI climbing systems are also recommended in developing countries like Ethiopia. Since high rise buildings are expected to be constructed in Addis Ababa in the near future, special formwork systems might have great applications by then. Therefore knowledge of such formwork system by local professionals is mandatory.

PERI ACS self-climbing systems is recent invention which can be operated without the use of crane. Projects which give priority for time than cost can use ACS climbing systems. As compared to other formwork systems, the cost of self-climbing system is high and it is recommended for the construction industry of Ethiopia for special projects only. Site visit was also made to special projects such as Tower 185 building construction project in Germany, see figure below. It is a project with height of 185m which is about 60 floors. Its construction is being conducted safely with climbing systems. Since the side of climbing system is high, workers on top floor do not feel discomfort and their productivity will not be affected.



Figure 4.11 Self Climbing Systems at Tower 185, Frankfurt

4.9 Transportation of Formwork on Site

The availability of the modern formwork systems in gang forms compels the use of cranes in their transportation on site. Therefore local contractors who decide to use modern formwork systems are recommended to have crane. PERI formworks are available in different weights and sizes. The quantities of elements to be lifted depend on the capacity of the available crane and the allowable stacking height specified by manufacturer.

Table 4.7 Weight of PERI formwork elements without accessories

Formwork Type	Size Range (L*H) or L*B	Weight Range
<i>Wall formworks</i>		
TRIO (normal)	30*60cm -330*240cm	15.6-398kg
TRIO (housing)	180*264cm-540*348cm	479-1680kg
MAXIMO	30*60cm -330*270cm	16.2-444kg
HANDSET	15*120cm-90*150cm	9.62-39.6kg
DOMINO	25*125cm-100*250cm	18.6-87.7kg
VARIO GT	100*240cm-250*600cm	137-791kg
RUNDFLEX	128*60cm-250*360cm	71-508kg
<i>Column formworks</i>		
RAPID	79*60cm-79*30cm	16.7-61.4kg
QUATTRO	73*50cm-73*350cm	32.3-206kg
LICO	70*50cm-70*30cm	16.8-72.6kg
SRS	Diam. 25cm*ht. 300cm -Diam.50cm*ht.300cm	23.2-171kg
<i>Slab formworks</i>		
SKYDECK	75*37.5cm-150*75cm	5.25-15.5kg
GRIDFLEX	20*183cm-200*100cm	5.8-20.3kg
MULTIFLEX	GT girder l=90 -600cm	5.3-35.4kg
TABLE MODULES	VT girder l=145-590cm 200*400cm-200*500cm	8.56-34.81kg 397-697kg
<i>Climbing systems</i>		
	FB 180/300 platform	318kg
	CB climbing bracket 240cm wide	112kg

As it is shown in table above the minimum weight of all elements is about 16kg and maximum is about 1700kg. The smaller element alone cannot cover much area and hence has to be transported in bulk which demands hoisting equipment or crane. For the large elements such as sky table, Trio H and other tall and wide elements, the requirement of crane is mandatory. Therefore contractors in Addis Ababa in particular and Ethiopia in general should have cranes so as to lift or lower the bulk formworks to the desired pace.

4.10 Rental Formwork

The renting of formwork materials has become the most important area of business for formwork manufacturers and companies selling construction equipment and materials. All businesses working in these fields have appropriate rental equipment inventories which are offered and utilized in the market. PERI has its method of computing rental rates and clauses related to acceptance tolerances of defects of formworks upon return. The rental company provides information about handling of formworks on site and repairs and cleaning before return.

4.10.1 Price Structure for Rental Formwork

The price of rental formwork comprises of the following:

- Formwork material rental charges e.g. per month,
- Non-recurring costs,
- Additional services (special services).

Any other services between the hirer and Rental Company are to be agreed upon in advance.

4.10.1a Formwork Material Rental Charges

It includes the following:

- Depreciation in value of the rented formwork as a result of use on the construction site.
- Standard repair of the materials outside of the equipment utilization period
- Interest charges for the capital employed
- Risk and profit

The maximum value of monthly rental rate considering the above factors is about 4.25% of value of formwork.

4.10.1b Non-recurring (One-Off) Costs

Non-recurring costs, which are incurred with every rental contract, include the following:

- ❖ Storage and handling costs
- ❖ Order processing
- ❖ Consultation and sales

The average value for one-off cost is 4.6% of the value of formwork.

4.10.1c Additional (special) Services

The hirer can request additional services from the rental company which are not specified above. These include, for example:

- Engineering services in the form of static calculations or formwork utilization planning
- Transportation
- Repair of damage resulting from inappropriate handling of the formwork materials
- Cleaning of the formwork materials after being returned to the rental company.

Cleaning cost is approximately 2% of the value of material and planning services can be up to 1%. Transportation cost depends on distance of site from the main store of the company to construction site.

Formwork renting practice in Addis Ababa was assessed by conducting interviews with formwork renting individuals and using questionnaires for contractors. The result shows that rental rate computation is not professionally done. No well organized company which rents formwork exists in Ethiopia. Most individuals who did this job are not professional and do not know scientific method of computing rental rates. All formworks whether it is new or depreciated have similar rates. The obligations of parties are not clearly stated. The conditions

of rent include only the collateral value, rental rate and the compensation for the lost and damaged formworks. The extent of damage is not stated well.

Steel panels are the only material available for rent and the current rate of 25Birr per m² per month or 3- 4Birr per m² per day for all rectangular sections and heights. Rental rate for circular steel panels of diameter 40cm and diameter 20 to 30 cm is 40Birr per m² per day and 30Birr per m² day respectively. Higher grade contractors do not usually rent formworks while lower class contractors and individuals are the majors parties involved in renting of formworks.

As renting of modern formwork system is new to Ethiopian construction industry, investors are welcomed to start the business. The start of renting system has an advantage in solving the liquidity problems of contractors. They will get the rental formwork systems without expending much money. Purchasing of new formwork systems might be difficult for some local contractors hence rental system is better option. To make the renting system formal, renting guidelines need to be prepared on national base, as in Germany. This will help in minimizing the dispute between the contractor and formwork investors.

CHAPTER FIVE

CONCLUSION AND RECOMMENDATIONS

5.1 Conclusion

From the study conducted the following conclusions are drawn.

- ❖ Alternative formwork materials such as plastic, glass reinforced plastic, fabric, etc are not well known and used by local construction companies. Steel panels and timber boards are the most commonly used formwork materials in Ethiopia. Some contractors start to use form lining with clothes to improve the surface quality of concrete. But the quality of surfaces is not as satisfactory as fabric form lining which has controlled rate of permeability.
- ❖ The cost of formwork is about 26% of the total cost of in-situ concrete in Addis Ababa. Formwork material costs more than form work labor costs in Ethiopia. But formwork labor cost is much more than material cost in developed countries such as Germany. Use of modern formwork can avoid the requirement for plastering and rectification work such as chiseling. Reduction in cost of about 5% of the new cost of modern formwork system, PERI MULTIFLEX, is obtained if plastering work is avoided or minimized.
- ❖ Productivity data are not well recorded by most of the contractors in Ethiopia. The use of modern formwork systems increases the current labor productivity of the formwork construction up to ten times. About 60% of the total time will be saved if new construction systems are adopted by construction firms in Ethiopia.
- ❖ All contractors use cement paper or other bags to avoid the loss of mortar from concrete during casting of concrete. As it is impossible to avoid the loss of paste using paper, the strength and durability of concrete is at risk. The strength of concrete if checked using non destructive tests is expected to be less than the result obtained from concrete samples taken during casting. Even though there are many factors which may contribute for the decrease in result, the loss of binding materials can be the major one.

- ❖ Health, safety and environmental regulations are not implemented in construction industry of Ethiopia. The form release agent that is currently used by contractors is not safe both for the workers and the structure. In general the current formwork construction practice in Ethiopia is not safe.
- ❖ Local consultants are not specifying the formworks to international standards. Detailed finishing requirements, design loads and releasing agents are not clearly specified and provided to contractors. Mainly steel panels and zigba or timber formworks are specified in most construction projects in Ethiopia.
- ❖ Formwork construction activity in Addis Ababa is seriously threatening the environment. More than three hundreds trees are cleared to cast about 100m² of slab. More trees will be cleared if other activities which need timber are considered.
- ❖ Formwork renting system is not well organized in Ethiopia. No scientific method of computing rental rates and no clearly stated conditions of rent is prepared by the renting individuals.
- ❖ TRIO Panel and VARIO GT 24 wall formwork systems are appropriate formwork systems for construction projects in Ethiopia. These formwork systems are easy to assemble, safe and relatively less costly.
- ❖ Among variety of slab formworks PERI MULTI FLEX is more suitable for the construction industry of Ethiopia. It is safe, provide good surface finish, environmentally friendly and relatively cheaper than other slab formwork systems.
- ❖ UZ beam formwork is best suited for beam construction. And PERI Trio, QUATTRO and VARIO which are easy to assemble and not as costly as aluminum forms are appropriate column formwork systems.
- ❖ Transportation as well as storage of formworks by some local contractors is not safe.

5.2 Recommendations

The following recommendations are given so that the problems in the formwork construction in Ethiopia are minimized:

- The government of Ethiopia should support local contractors in importing modern formwork systems free of duty and provide loans to contractors so that they can purchase the desired formworks. Long term loan with fair interest rate from both government and private banks will alleviate the liquidity problems of most contractors in owning new formwork systems.
- Regulatory bodies such as Ministry of Works and Urban Development should prepare standard specification which incorporates details of materials of formwork, appropriate release agents, stripping time, strength requirements for different structures etc. Minimum requirements which suits to Ethiopian case should be set by such bodies.
- Design tables which guide contractors in designing their formworks should be prepared on national level by regulatory bodies.
- Regulatory body should include the use of standard/modern formworks as the requirement for licensing of at least higher grade contractors.
- Consultants should prepare detailed specification either by stating the required performance such as level of finishing needed and let the contractor choose appropriate formworks or provide the detail for the formwork materials and construction methods so as to help contractors. Therefore consultants should not specify only steel or timber as it is used to be. Specifications should vary from project to project depending on its complexity and level of finishing required.
- Contractors should be able to design their formwork systems for the sake of safety of their workmen and third party. The design will also help them in achieving economy in formwork construction. For instance very closely spaced props in Ethiopian construction projects should be improved through designing of the formworks. This can be done by implementing new systems such as metal props whose properties are well known and easy to design.

- As construction industry has role in deforestation of trees, policy which prohibits contractors from using timber should be enacted. The policy should consider contractors grade and type of construction projects. Contractors of grade one to three should be prohibited first and the policy will gradually apply to other grade of contractors too. All contractors which are involved in construction of high rise buildings should not use timber formwork and scaffolding system. Approval for construction should not be given unless the client or contractors agree to use alternative materials instead of timber.
- Plantation of trees which grows and harvested in short period of time should be made by all individuals and concerned bodies in the country.
- Regulatory body should enact and follow the implementation of regulation on safety, health and environment in construction. International or local consultants should extensively participate in preparation of regulations.
- Local contractors need to be aware of the current technology on formwork construction either through joining university or studying by themselves. Many modern formwork systems other than PERI are available internationally and contractors are advised to compare and choose formwork systems which are not addressed by this study.
- Universities should incorporate courses on formwork construction in their bachelor and masters programs. Graduates from the bachelor programs are directly involved in construction of formwork without given sufficient knowledge on issue. Hence universities should revise their curriculum so that well qualified professionals who get awareness on safety, quality, economic and environmental requirements in construction of formwork will be graduated.
- Associations such as Civil Engineering, Contractors and Construction Management should prepare guidelines on rental systems in Ethiopia. They should also encourage professionals to conduct further research on formworks and scaffolds systems in Ethiopia so that the problems in the construction industry will be alleviated.

BIBLIOGRAPHY

1. Abu Dhabi Sewerage Services Company (2008), *General Specification for Civil Works , division 3 concrete*, UAE.
2. ACI 117-90, *Standard Specifications for Tolerances for concrete Construction Materials*, Farmington Hills.
3. ACI 318-05, *Building code requirement for Structural Concrete*.
4. ACI committee E-701, *Aggregates for Concrete*, ACI Education Bulletin E1-07, USA
5. Andre Tovey etal. (2007), *Design and Construction using Insulating Concrete Formwork*, Cromwell Press, Trowbridge, UK.
6. Alibala Group, *Formwork Ties*, <http://www.alibaba.com/showroom/formwork-tie.html>
7. American Society of Concrete Contractors ASCC (2008), *The Contractor's Guide to Quality Concrete Construction*, USA
8. Neville, A.M (1994), *Properties of Concrete third edition*, Longman Group UK.
9. Arthur Lyons (2007), *Materials for Architects and Builders*, Elsevier's Science & Technology Rights Department, Oxford, UK.
10. Australian National Training Authority ANTA (1997), *Formwork*, Victoria, Australia.
11. Awad Hanna (1999), *Concrete Formwork Systems*, University of Wisconsin-Madison, USA.
12. Boral Company, Formwork hardware brochure, 5 Mackie Way,rendale,Australia
13. Bluebay, *Formwork Products brochures*, <http://www.bluebaybp.co.uk>.
14. British Standards BS8110-1997 part 1, *Structural Use Concrete*.
15. Bomac Engineering Pvt ltd, *How to Select the Right Crane for your Business*, a guide to Workstation cranes, Victoria, Australia.
16. Cement and Concrete Association of New Zealand, *Formwork for Concrete*, <http://www.cca.org.nz/shop/downloads/chapter%2014.pdf>.

17. Cimenterie Nationale, *Cement production*, <http://www.cimnat.com.lb>, Lebanon.
18. City University of Hong Kong, *Conditions and Constraints in the Formwork Systems for Complex High-rise Building*, Hong Kong, China.
19. Construction Safety Association of Ontario (2008), *Formwork health and Safety*, Canada.
20. Construction Safety Association of Ontario (2008), *Safety Manual*, <http://www.csao.org>
21. Motzko, c. (1989), *Ein verfahren Zur Ganzheitlichen Erfassung und Rechnergestützten Einsatzplanung Moderner Schalungssysteme*, TU Darmstadt.
22. Motzko, c. (2009), *Vorlesungsunterlagen Baubetrieb A1*, Institute für Baubetrieb, Technische Universität Darmstadt.
23. Christine Beall (2004), *Masonry and Concrete for Residential Construction*, the McGraw-Hill Companies, <http://www.digitalengineeringlibrary.com>
24. Concrete and Bridge Development Group, *Controlled Permeability and Permanent Formworks*, Current Practice Sheet number 10 and 12, UK.
25. Concrete Society (1995), *Formwork a guide to Good Practice*, UK.
26. CONSTRUCT Concrete Structures Group (2010), *Best Practice Guides For In-Situ Concrete Frame Buildings*, Camberley, England.
27. Dextra Group ,*Formwork ties and Accessories*, Brickfields Business Park, Gillingham, Dorset SP8 4PX, UK
28. DIY, *Formworks*, <http://www.builderbill-diy-help.com/formwork-materials.html>.
29. Douglas ,D. et al (2006), *Construction Equipment Management for Engineers, Estimators, and Owners*, Boca Raton, USA
30. Edward, G. (2008), *Concrete Construction Engineering Hand Book*, Second Edition, New Brunswick, New Jersey.
31. Ethiopian Building Codes Standard, EBCS2 (1995), *Structural Use of Concrete*, Addis Ababa.
32. Frank International Technologies for the Construction Industry, *Stremaform formwork Hand Book*.

33. Formwork Direct International LTD, *Formwork Systems and Concrete Accessories*, UK.
34. Fraser Brown & Stratmore ltd, *BIO-R Release Agent for concrete Formwork*, Lower Hutt, New Zealand.
35. GEOPLAGEOPLAST S.p.A, *Geoplast Brochure*, Grantorto(PD) – Italy
36. Handbuch Arbeitsorganisatio Bau (1986), *Richtzeiten Schalarbeiten Rahmenschalung Wände*, Neu-Isenburg, Germany.
37. Hong Kong Institute of Construction Managers (2006), *Timber Formwork*, Practice Notes for construction Managers, Hong Kong China.
38. Industrial Packaging ltd, *Form-A round-Column*, Killarney Road, ray, Wicklow Ireland.
39. JMC ltd (2006), *Formwork manual*, Ahmedabad, India.
40. J.M.Dinwoodie (1999), *Timber Its nature and behavior*, University of Wales, UK.
41. John Richardson (2006), *Supervision of Concrete Construction*, London, England.
42. Keerthi Bharathi (2008), *Formwork in Construction*, Bangalore Region LuLu, Kochi.
43. Kamran M. Nemati (2007), *Formwork for Concrete*, University of Washington, Department of Construction Management.
44. Lanotec Australia Pty Ltd, *Release Agent Product Data Sheet*, www.lanotec.com.au
45. Liebherr Group (2010), *Mobile Cranes brochures*, Ehingen, Germany.
46. Manfred Hoffmann (2006), *Zahlentafeln für den Baubetrieb*, weisbaden, Germany.
47. Newman et al (2003), *Advanced Concrete Technology*, Butterworth-Heinemann, UK.
48. Paul Jaquin (2008), *Rammed Earth Formwork*, university of Durham, <http://www.historicrammedearth.co.uk>.
49. PERI (2009), *Formwork Scaffolding Engineering Hand book*, weissenhorn Germany.
50. PERI GmbH (2003), *Tie Systems Handbook*, Wiessenhorn, Germany.
51. PERI GmbH(2005), *Climbing Formwork Hand book* ,Wiessenhorn, Germany
52. PERI GmbH(2003), *Site Equipments Hand Book* ,Wiessenhorn, Germany

53. Philip Malone (1999), *Use of Permeable Formwork in Placing and Curing Concrete*, U.S. Army Engineer Research and Development Center, Washington, DC.
54. RMD New Zealand Pvt Ltd, *Formwork Tie Systems*, New Zealand
55. Roberto Torrent, *Evaluating the Long-Term Effectiveness of a Permeable Formwork Liner*, <http://www.zemadrain.com>.
56. Rohan Rupasinghe and Éanna Nolan (2007), *Formwork for modern, efficient concrete construction*, BRE, Garston, Watford.
57. Robert Linberg, *Aluminum in Concrete*, Reynolds Metals Company, Richmond, Virginia.
58. Semtra Kosmatka et al. (2003), *Design and Control of Concrete Mixtures 14th Edition*, Portland cement Association, Skokie, Illinois, USA.
59. Sidney Freedman, *Composition of form release Agents*, Precast Concrete Institute Chicago, Illinois.
60. Sidney Ray (1995), *Analysis and Design of reinforced concrete Structures*, Glasgow, Great Britain.
61. Theodor Hugues et al (2004), *Timber Construction*, Faculty of Building Construction and Materials, Technical University of Munich, Germany.
62. Tilak Bhattacharya, *Mivan formworks*, http://www.architectjaved.com/mivan-formwork/aluminium_formwork.html
63. Tool base company, *Concrete Admixtures*, <http://www.toolbase.org/Technology-Inventory/Foundations/concrete-admixtures>.
64. Wanfred Chen et al (2003), *Civil Engineering Handbook Second Edition*, CRC Press LLC, United States of America.
65. Wikipedia free encyclopedia, *Formwork and False work*, [http:// en. Wikipedia. Org /wiki/formwork](http://en.Wikipedia.Org/wiki/formwork).
66. Wikipedia free encyclopedia, *Crane (machine)*, [http://en.Wikipedia.org/ wiki/ Crane](http://en.Wikipedia.org/wiki/ Crane)
67. Zentralverband der Deutschen Baugewerbes (1982), *Arbeitszeit Richtwerte Hochbau*, Bonn, Germany.

APPENDIX ONE
QUESTIONNAIRES

A .General Information

1. Name of your Company _____
2. Grade of the company (please specify as BC 1, 2...or GC1, 2...) _____
3. Your position in the firm _____
4. The largest concrete structure that your company had constructed (please specify in terms of storeys for building) _____

B. Formwork Materials and Costs

1. Which formwork materials does your company use? (Please tick the box under column 2).
Please rank the materials in order of usage (1 for mostly used, 2 for less used etc.)
under column 3.

Material	use (x) sign for the material you used	Rank for material
Timber boards		
Plywood		
Steel		
Aluminum		
Precast Concrete		
Plastic		
Hardboard		
Glass Reinforced Plastic (GRP)		
Wood particleboard		
Cardboard		
Fabric		

Other materials, please specify, _____

2. Please match the formwork material with the structural elements in table below. (tick the box under the member)

<i>Material</i>	<i>Structural Member</i>				
	<i>Footing pad</i>	<i>Column</i>	<i>Beam</i>	<i>Slab</i>	<i>Wall</i>
Timber boards					
Plywood					
Wood particleboard					
Hardboard					
Steel					
Aluminum					
Plastic					
Cardboard					
Precast Concrete					
Glass Reinforced Plastic(GRP)					
Fabric					

Other, please specify _____

3. Please specify the reusability of your formwork. Describe the number of times you use before disposing of the form material. **(Please fill the number in the table)**

<i>No.</i>	<i>Form Material</i>	<i>No of reuses</i>
1	Steel	
2	Timber board	
3	plywood	
4	Aluminum	
5		
6		

4. What is the source of your formwork materials? **(Please circle on the letters of your choices) you can choose more than one item.**

- a. Rental
- b. Owning(purchase from local market)
- c. Owning(Import from abroad)
- d. Produce by company itself

5. If you produce timber formworks by yourself; is the supplier of the wood certified?
 Certification is usually issued if the supplier guarantees the replacement of trees.

Yes No

If yes, please specify certifying Authority in Ethiopia _____

6. If you import formworks; please describe the product types _____

7. Is there any support made by government in importing such formworks? Yes No
8. From which formwork rental companies do you hire formworks? (please circle on the letter of your choice)
- a. Local Companies
 - b. International Companies(imported)
 - c. Both
9. Is there any contract document for the rental formwork? For instance, clauses related to damaged formwork, cleaning, maintenance during return, rental rate computation etc.(please tick in the boxes)
- Yes No

Please, describe if you have different rental system_____

10. Please fill the current rental rate and purchase price (of new element) for the following formwork materials.

<i>No.</i>	<i>Formwork Material</i>	<i>Formwork sizes</i>	<i>Rental rate Per m² per day</i>	<i>Purchase price per m²</i>
1	Steel			
2	Timber boards			
3	Aluminium			
4	Plywood			

11. Please fill the average direct cost components for the slab and column formwork construction in the following table?

No.	Formwork Material	Material cost for slab (Birr/m ²)	Labor cost for slab (Birr/m ²)	Equipment Cost for slab (Birr/m ²)	Material cost for column (Birr/m ²)	Labor cost for column (Birr/m ²)	Equipment cost for column (Birr/m ²)
1	Timber						
2	Steel						
3	Aluminium						
4	Plywood						
5							
6							

12. What is the current direct cost of concrete work?(please use birr per m³)

Concrete materials cost = _____

Concrete labor cost = _____

Concrete equipment cost = _____

13. Please would you quote the average unit price for two coats of cement sand plastering?
_____ Br/m²

C. Formwork Construction Systems

1. Please choose the formwork systems that your company is using or specify other methods if any. (please write yes or no in the space provided)

i. Modern formwork Systems

• Climbing systems _____ other system, specify _____

• Gang systems _____

- Flying systems _____

- Tunnel systems _____

ii. *Conventional formwork systems*

- Conventional wood formworks _____ other system , specify _____

- Conventional steel formworks _____

2. Please explain your reason, if you are not using modern formwork systems.

3. Which method of erecting and stripping formwork is used in your company?(tick in the box)

Using labor only in transporting, erecting and stripping

Using labor and Cranes in transporting, erecting and stripping

Using labor and other hoisting equipments in transporting, erecting and stripping

Please describe if there are other methods _____

4. Would you please describe the average productivity of labor in erecting and stripping of formworks?(describe in terms of m²/hr)

<i>Formwork systems</i>	<i>Member</i>							
	<i>column</i>		<i>Beam</i>		<i>Slab</i>		<i>Wall</i>	
	<i>erecting</i>	<i>stripping</i>	<i>Erecting</i>	<i>stripping</i>	<i>erecting</i>	<i>stripping</i>	<i>erecting</i>	<i>stripping</i>
Conventional wood formworks								
Conventional steel formwork								

5. How long do you wait before stripping slab and beam soffit formworks? (please fill the average number in the space provided)

- a. Slab (steel formwork casted with OPC cement) _____ days
- b. Slab (steel formwork casted with PPC cement) _____ days
- c. Slab (timber formwork casted with OPC cement) _____ days
- d. Slab (timber formwork casted with PPC cement) _____ days
- e. beam (steel formwork casted with OPC cement) _____ days
- f. beam (steel formwork casted with PPC cement) _____ days
- g. Beam (timber formwork casted with OPC cement) _____ days
- h. Beam (timber formwork casted with PPC cement) _____ days

6. Did you attempt to re-shore the slab and remove the formwork sheets early? Yes No
If yes, in how many days did you remove the soffit formwork? _____

7. Are you well satisfied with the quality of concrete surfaces after stripping of formwork?
 Yes No. If No, what is your opinion in achieving good quality concrete surfaces

8. Is the grout (cement slurry) loss from column formwork, beam formwork or other members controlled? Yes No

Do you use cement paper bag or other material in controlling the loss of grout at the junction of formwork elements? Yes No

Please describe your mechanisms _____

D. Design and Specification of Formworks

1. Have you ever designed the formworks for the applied loads? (please tick in the box)

Yes No

If yes, which design codes (standards) do you use? EBCS, ACI, BS, DIN, specify if other_____.

What is your opinion (if any) on the significance of formwork design? _____

2. Which type of props for slab and beam do you often use? Please rank in order of usage, if you use more than one material. That is (1 for highly used, 2 for less used etc.)

Wooden Steel Aluminum other, specify_____

3. What is the *average* spacing and height of wooden props for slabs? (Please refer the following sketch and write the unit in meter)

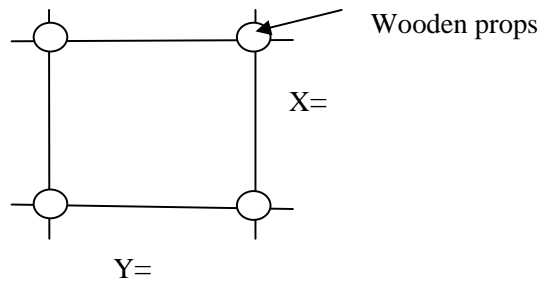

X=_____

Y=_____

Avg.Diameter = _____

Avg.Height = _____

Please sketch or describe if you have different bracing systems for props;

4. How many times do you reuse the timber props? On average, _____ times.

5. Which formwork materials are commonly specified by local consultants? Please rank the materials in order of specification (1 for most specified, 2 for less specified etc.)

1. _____ 2. _____ 3. _____

4. _____

6. Are you satisfied with current formwork specifications by local consultants? Yes No
If No ,what do you propose to improve it, _____

7. Do consultants provide the design loads to the contractor? Yes No

8. Do consultants provide the minimum strength of concrete, for beams and slabs in particular, before removal of formworks? Yes No

9. Is there any general specification of formworks made by the regulatory body (MWUD) which serves as guide? Yes No; if there are others, please list them

E. Safety and Environmental Issues during Formwork Construction

1. Is there any regulations concerning health, safety and environment for construction industry in Ethiopia? Yes No

2. Please describe if there are regulations specific to formwork construction. _____

3. Do you have any record of injuries, deaths or other health problems to your workmen during formwork production and construction? Yes No

If yes, Please choose one or more of the following risks.

- a. Respiratory hazards from sawdust during production of timber formworks
- b. Respiratory and other hazards from form oils
- c. Physical hazards due to fall from ladder, from slippery surfaces of oiled forms etc.
- d. Physical hazards due to strike by formwork panels or hammer during formwork construction or handling.
- e. Injury due to collapse of formwork.

Please describe if there are others _____

4. Do you provide safety clothes such as gloves, goggles, helmets etc. to your workmen?

Yes No

Please describe if you have other safety measures: _____

5. Which type of form release agent does your company use? (please circle on the letter/s of your choice/s)
- a. Burnt oil
 - b. Neat oil
 - c. Neat oil with surfactant
 - d. Water soluble emulsions
 - e. Chemical release agents

Please describe if you use other form release agents; _____

6. Please describe the effect of burnt oil, if any, on environment and structure; _____

7. Do you have mechanisms of controlling dosage of formwork release agents? Yes No
If yes, please describe the mechanisms; _____

_____.
8. It is known that currently Ethiopia has only 3% of the land covered by the forest and still use timber as formwork material. Do you have recommendation for policy change regarding the use of timber in construction? Please describe: _____

_____.
9. Do you agree if contractors of class 1 -3 are prohibited from using timber formwork?
 Yes No. What would be the consequence, if such policy is enacted?

_____.
10. Do you have other option (say all contractors or greater than class 5 contractor etc) than specified in Q.9 regarding prohibition of timber formwork? _____

_____.
11. Is there alternative formwork which you recommend to safeguard our environment?
Please describe _____

_____.

Thank you!

DECLARATION

I, the undersigned, declare that this thesis is my original work and has not been presented for a degree in any other university and that all sources of materials used for the thesis have been duly acknowledged.

Name: Argaw Tarekegn

Place: Addis Ababa, Ethiopia

Date of Submission: _____

Signature: _____

Title of the Thesis:

“Application of Modern Formwork Systems in Ethiopia”

This thesis has been submitted for examination with my approval as university advisor.

Name: Professor Abebe Dinku (Dr.-Ing)

Signature: _____

Date: _____