

Addis Ababa Institute of Technology

School of Graduate Studies

Energy Center

**Adopting Building Integrated Photovoltaics (BIPV) for
Harnessing Green Economy in Ethiopia: A Study on the
Design, Modeling and Economic Analysis of Grid-Tied BIPV**

A Thesis submitted to the School of Graduate Studies of Addis
Ababa Institute of Technology in partial fulfillment of the Degree
of Master of Science in Energy Technology

By: Tsion Berhanu

Advisor: Dr.-Ing. Ababayehu Assefa

January 2015

Adopting Building Integrated Photovoltaics (BIPV) for Harnessing Green Economy in Ethiopia: A Study on the Design, Modeling and Economic Analysis of Grid-Tied BIPV

By: Tsion Berhanu Dibeya

APPROVED BY BOARD OF EXAMINERS

Dr. Solomon Abebe	_____	_____
Head, Energy Center	Signature	Date
Dr.-Ing. Ababayehu Assefa	_____	_____
Advisor	Signature	Date
Dr.-Ing. Edessa Dribsa	_____	_____
Internal Examiner	Signature	Date
Dr. Tesfaye Dama	_____	_____
External Examiner	Signature	Date

DECLARATION

The work in this thesis is based on the study carried out at the Addis Ababa University, Addis Ababa Institute of Technology, Energy Center. This thesis is a presentation of my original work and has not been presented for a degree in any other university. Wherever contributions of others are involved, every effort has been made to indicate clearly with due reference to the literature.

Abstract

Contrary to add-on Photovoltaics (PV), Building-integrated PV (BIPV) refers to the application of PV arrays where they are integral parts of the building envelope having the function of producing electricity as well. Ethiopia, as a country having average daily solar radiation of 5.2kWh/m², can make use of this technology as a means of achieving the country's goal of expanding electric power generation and green growth strategy. In addition, by producing power close to the point of use, the technology shall contribute to the reduction of the current 23% transmission and distribution losses encountered in the power system of the country. To this end, the opportunities of meeting some of the country's electricity demand by introducing grid-tied BIPV in commercial and residential buildings of urban Ethiopia were investigated by taking the new Zemen Bank Headquarter 30-storey Building as a case study. A detailed design, simulation and economic analysis of a grid-tied BIPV system were conducted for four different scenarios of the building using PVsyst software. The results of the simulation showed that with an optimal design a significant amount of energy, 897,000kWh/year, which covers 69.54% of the estimated demand of the building can be generated. This can save up to 26,910USD per year based on the current electricity tariff of Ethiopia. The simulations of the four scenarios revealed that best results can be achieved by considering the system starting from the initial architectural design of the building rather than retrofitting an existing one. On the other hand, the economic evaluation resulted in an energy cost of US\$0.11/kWh for the optimal design which is much higher than the prevailing electricity retail price of Ethiopia, US\$0.03/kWh. From this it was concluded that grid-parity shall be achieved in the long run since the costs of PV modules is dropping while their efficiency is rising.

Acknowledgement

Above all, I would like to thank the Almighty God for helping me with all my endeavors to complete my studies.

I would like to express my special appreciation and thanks to my advisor Dr.-Ing. Abebayehu Assefa, for his patience, guidance, support, encouragement and insightful comments not only during my thesis work but throughout my entire studies at the Energy Center.

My special thanks also go to Daniel Assefa, the Director of JDAW Consulting Architects and Engineers, and Dagim Terefe, an architect in the same firm, for providing me with all the data needed for my research and for all their support.

My sincere gratitude goes to my mother for raising me and helping me to be the person that I am today and my sister and brother for their support and care since my childhood.

I would like to express my heartfelt thanks to my husband for all the support and encouragement he gave me during my graduate studies.

Last but not least, I would also like to thank Tesfaye Wubishet for believing in me and supporting me during my studies.

Table of Contents

<i>Abstract</i>	iii
Acknowledgement	iv
Table of Contents	v
List of Tables	viii
List of Figures	ix
Introduction	1
1.1 Background	1
1.2 Problem Statement	2
1.3 General and Specific Objectives	3
1.3.1 General Objective.....	3
1.3.2 Specific Objectives.....	3
1.4 Materials and Methods	3
1.5 Significance of the Research	4
1.6 Limitations	4
1.7 Organization of the Research Report	4
Chapter 2	5
Literature Review	5
2.1 Photovoltaics (PV) Technologies Basics	5
2.1.1 The Photoelectric Process	5
2.1.2 Types of Photovoltaic Technologies	6
2.1.2.1 Monocrystalline Silicon	6
2.1.2.2 Polycrystalline Silicon	6
2.1.2.3 Thin-Film Technologies.....	6
2.2 Building Integrated Photovoltaics (BIPV)	7
2.2.1 Types of Building Integrated Photovoltaic Technologies	8
2.2.1.1 Grid-Tied Systems	8
2.2.1.2 Stand-Alone Systems	9
2.2.2 Components of Grid-Tied BIPV Systems	10
2.2.2.1 PV Modules	10
2.2.2.2 Inverters	11
2.2.3 Types of BIPV Products and Integration Techniques	14
2.2.3.1 BIPV Foil Products	14

2.2.3.2 BIPV Tile Products	14
2.2.3.3 BIPV Module Products	15
2.2.3.4 Solar Cell Glazing Products	15
2.2.4 Global Trend in BIPV Technologies	16
2.3 PVsyst Software Overview	17
2.3.1 PV Module Model Implemented in PVsyst	18
2.3.2 Array and Inverter Sizing in PVsyst	19
2.3.3 System Losses in PVsyst	21
Chapter 3.....	22
Materials and Methods	22
3.1 Design Steps of Building Integrated Photovoltaic (BIPV) System	22
3.1.1 Screening the Application Site and the Building	23
3.1.2 Tilt and Orientation of Building Surfaces	24
3.1.3 Overshadowing	25
3.1.4 Partial Shading	26
3.1.5 Zoning a PV Array	26
3.1.6 Temperature Effect.....	26
3.1.7 Daily Insolation	27
3.2 Load Analysis.....	28
3.3 Input Data Used for Simulation by PVsyst Software	35
3.3.1 Project Designation	36
3.3.1.1 Definition of Geographic Site	37
3.3.1.2 Meteorological Data.....	38
3.3.1.3 Albedo Settings	39
3.3.2 Input Parameters for the Four Scenarios	43
3.3.2.1 Orientation	43
3.3.2.2 System Definition	46
3.3.2.3 Detailed Losses	53
3.4 Economic Evaluation.....	54
Chapter 4.....	58
Results and Discussion	58
4.1 Energy Production.....	58
4.2 Results of Economic Evaluation.....	64

Chapter 5	66
Conclusion and Recommendation	66
5.1 Conclusion.....	66
5.2 Recommendation.....	68
Bibliography	69
Appendix	71

List of Tables

Table 2.1: PV Cell Technologies and Efficiencies	7
Table 3.1 Solar Access of Parts of the Building	24
Table 3.2 Orientation and Tilt of Parts of the Building Suitable for PV Integration	25
Table 3.3 Power Reduction for Crystalline Silicon Modules for Various Mounting Types	27
Table 3.4 Load Estimation of Office Appliances [18].....	33
Table 3.5 Estimated Yearly Load Requirement.....	35
Table 3.6 Daily Minimum and Maximum Mean Temperatures of Addis Ababa	41
Table 3.7 Orientations Implemented for Each Scenario	44
Table 3.8 Available Area for PV Integration.....	47
Table 3.9 Specifications of PV Modules Used for Each Scenario.....	48
Table 3.10 Inverter Specifications Selected for Each Scenario	52
Table 3.11 Input Values for Detailed Losses	54
Table 3.12 Input Data Used for Economic Evaluation	56
Table 4.1 Results of Array Sizing for Each Scenario	58
Table 4.2 Percentage Difference of Each Scenario from the Optimum.....	59
Table 4.3 Results of Economic Evaluation of Each Scenario.....	64
Table 4.4 Energy and Financial Saving of Each Scenario	65

List of Figures

Fig. 2.1 PV Cell, Module and Panel	5
Fig. 2.2: Schematic Diagram of a Grid-Tied PV Power System	9
Fig. 2.3: Schematic Diagram of a Stand-Alone PV System	10
Fig. 2.4 Example of BIPV Foil Product	14
Fig. 2.5 Example of BIPV Tile Product	15
Fig. 2.6 Example of BIPV Module Product	15
Fig. 2.7 Example of BIPV Solar Cell Glazing Product	16
Fig. 2.8 BIPV Market Revenue	17
Fig. 2.9 BIPV Demand Estimates in Ethiopia	17
Fig. 2.10 Equivalent Circuit for One Diode Model of a PV cell	18
Fig. 2.11 I-V Characteristic of PV Module	19
Fig. 3.1 Design Process of a BIPV System	22
Fig.3.2 Zemen Bank Headquarter Building.....	23
Fig. 3.3 Annual average of daily insolation on a horizontal plane (tilt=0°) across the world	28
Fig. 3.4 Energy Consumption of Various Elevator Technologies	34
Fig 3.5 First User-Interface of PVsyst Software.....	36
Fig 3.6 Project's Designation Dialog Box	37
Fig.3.7 Project Location and Geographical Coordinates	38
Fig.3.8 Map Showing the Place of Construction	38
Fig 3.9 Monthly Meteorological Data of Addis Ababa	39
Fig 3.10 Albedo Monthly Values	40
Fig 3.11 Average Maximum and Minimum Temperatures of Addis Ababa (Source: World Weather and Climate Information)	40
Fig. 3.12 Definition of Design Parameters	43
Fig 3.13 Orientation of Façade Surface	44
Fig. 3.14 Orientation of Rooftop and Podium	45
Fig. 3.15 Modified Orientation of Facade Surface for the Second Scenario	45
Fig. 3.16 I-V Curve of the MegaSlate II Module for Different Irrandiance Levels.....	49
Fig. 3.17 Power Curve of MegaSlate II Module for Different Irrandiance Levels.....	49
Fig. 3.18 I-V Curve of the Schott Solar AG, PROTECT ASI CLIME1 12 Module for Different Irrandiance Levels	50
Fig. 3.19 Power Curve of the Schott Solar AG, PROTECT ASI CLIME112 Module for Different Irrandiance Levels	50
Fig. 3.20 I-V Curve of 3S Swiss Solar Systems Façade Module for Different Irrandiance Levels	51
Fig. 3.21 Power Curve of 3S Swiss Solar Systems Façade Module for Different Irrandiance Levels	51
Fig 3.22 System Definition Dialog Box	53
Fig. 3.23 Benchmark 2010 Commercial PV System Price: Breakdown by Element	55

Fig 3.24 PVsyst Dialog Box used for Input Data of Economic Evaluation.....	57
Fig 4.1 Normalized Productions (per installed kW _p): Nominal Power 326kW _p (First Scenario).....	60
Fig 4.2 Normalized Productions (per installed kW _p): Nominal Power 553kW _p (Second Scenario)	61
Fig 4.3 Normalized Productions (per installed kW _p): Nominal Power 587kW _p (Third Scenario)	61
Fig 4.4 Normalized Productions (per installed kW _p): Nominal Power 235kW _p (Fourth Scenario).....	62
Fig.4.5 Loss Diagram of the BIPV System (First Scenario).....	62
Fig. 4.6 Loss Diagram of the BIPV System (Second Scenario)	63
Fig.4.7 Loss Diagram of the BIPV System (Third Scenario)	63
Fig.4.8 Loss Diagram of the BIPV System (Fourth Scenario)	64

Chapter 1

Introduction

1.1 Background

Electric power based on renewable energy sources is among the fundamental drivers of green growth enabling opportunities for green cities, industries and technologies. For Ethiopia, it is believed that green growth is a necessity to tackle poverty as well as an opportunity to realize the country's potential of renewable resources [1].

Considering this fact, the Ethiopian government has come up with Scaling-Up Renewable Energy Program (SREP) one of whose objectives is the development of alternative energy from renewable sources such as wind, geothermal, solar and biomass. Accordingly, the country is expected to be transformed into Climate Resilient Green Economy by 2025 [2].

To achieve this, EEP (former EEPCo), the state owned power utility of Ethiopia, has been aggressively investing in the hydroelectricity sector and implementing few wind energy projects while less focus has been given to solar energy. Nevertheless, photovoltaic technology (PV) which is the direct generation of electricity from sunlight could be one way of achieving the SREP's goal. The use of PV technology for rural electrification where the national grids do not reach has started to flourish in recent years. This application of the technology can also be extended to urban areas by being imbedded into the fabrics of large commercial as well as residential buildings.

In a lay-on or additive solution, PV arrays are mounted on special support structures, the PV system being an additional structural element with the sole function of generating electricity. In contrast, building-integrated PV (BIPV), the subject of this study, refers to the application of PV arrays where they are integral parts of the building envelope having the function of producing electricity as well. Hence, the PV arrays can be regarded as multifunctional building elements that provide both shelter and power [3].

BIPV shifts power generation away from being large scale and produces electricity close to the point of use and hence provides the additional benefit of reducing transmission and distribution losses.

Thus, with the current boom in construction of commercial and residential buildings in Ethiopia, adopting grid-tied building integrated photovoltaic technology could be one step for turning buildings green while playing a partial role in achieving the green growth strategy of the country which aims to attain zero net carbon emission by 2025.

1.2 Problem Statement

Ethiopia generates about 93% of its electricity from renewable energy sources mainly from hydropower [2]. However, this hydro dominated power system has risks associated with it including vulnerability to climatic shocks. On the other hand, the accelerating socio - economic growth and development of Ethiopia has caused increased energy consumption and unmet demand for the last 7 years [2].

The construction boom in the country has caused the rising of tall buildings for luxury hotels, shopping malls, apartment blocks, etc., particularly in Addis Ababa. The commercial and residential sectors already consume about 60% of the total generated electricity and with the continual growth of the sector the figure is expected to increase significantly [3].

The average daily solar radiation of Ethiopia is 5.2 kWh/m^2 which is among the highest solar radiation category of the world. The total BIPV technical potential for Addis Ababa at annual average daily radiation of $3.0 \text{ kWh/m}^2/\text{day}$ is about 2.8 TWh per year which almost equals the existing power plants firm energy generation capacity [3].

To this end, this study shall investigate the opportunities of meeting some of the country's electricity demand by introducing grid-tied BIPV in commercial and residential buildings of urban Ethiopia while contributing to the reduction of the current 23% transmission and distribution losses [2] encountered in the power supply system of the country.

1.3 General and Specific Objectives

1.3.1 General Objective

The general objective of this study is to contribute for the Ethiopian government's Green Growth Strategy and to forward relevant inputs to energy policy and regulation makers.

1.3.2 Specific Objectives

This study investigates the potential of adopting grid-tied BIPV projects for commercial and residential buildings of the cities of Ethiopia by taking Zemen Bank Headquarter Building as a case study. The specific objectives of the study are the following:

1. Preliminary design of the BIPV system which includes searching for insight on possibilities of integration approaches and selection of appropriate solar technologies;
2. Detailed technical design and modeling of the grid-tied BIPV system;
3. Simulating the designed model;
4. Economic analysis of the project

1.4 Materials and Methods

The design, modeling and simulation of the BIPV system are done using PVsyst software. These incorporate the full featured study and analyses of the project including the economic analysis. PVsyst is a software for the study, sizing, simulation and data analysis of complete PV systems and is suitable for grid-connected, stand-alone and DC-grid systems. It offers an extensive meteorological and photovoltaic components database and includes a Computer Aided Optimization tool for detailed shading analysis [4].

For this study, general site data, electricity demand of the building under consideration and meteorological data of Addis Ababa were required. These data were obtained by undertaking site investigation, visiting the Consulting Architects' Office, studying the electricity demand of large commercial buildings and by importing the meteorological data of Addis Ababa from NASA's website.

1.5 Significance of the Research

The study shall contribute for the Ethiopian government's ambitious plan of developing alternative renewable energy sources and the Green Growth Strategy of attaining zero net carbon emission by 2025. The results of the study are expected to change the perspectives of architects and engineers of the country towards considering solar buildings as a sustainable means of producing electricity in the urban environment of Ethiopia.

1.6 Limitations

Conventional energy production in Ethiopia is based on centralized power stations composed of many hydro and few wind power stations. Despite the recent use of photovoltaic technology for rural electrification, large scale solar electricity production got less focus in the country until the recent phenomenon of a contract signing between EEP (former EEPCo) and two US based companies (Global Trade and Development Consulting together with its Project Development Partner, Energy Ventures) for a solar energy project. Having three one hundred megawatt (100MW) solar power stations in Eastern Ethiopia, the project is believed to be the first of its kind and big in terms of the amount of power generated from the sector in the country [5].

On the contrary, PV systems integrated into buildings have not been implemented yet and the country's utility company is not currently focusing on such kind of decentralized energy production form. Therefore, the absence of regulations for utility interconnection issues puts a limitation on this study.

1.7 Organization of the Research Report

The research report has five chapters. An overview of the general and specific objectives, problem statement, methodology and limitations of the research are given in chapter one of the report.

The second chapter provides a review of literatures for theoretical background of PV technologies and the software used for the simulation. The third chapter discusses about the materials and methods used for the research while chapter four summarizes the results. Finally, the conclusion and recommendation of the study are presented in chapter five.

Chapter 2

Literature Review

2.1 Photovoltaics (PV) Technologies Basics

PV systems work by converting sunlight directly into DC (direct current) electricity. The conversion process takes place in solar or PV cells which are usually made of silicon. PV cells are connected electrically in series and/or parallel to produce higher voltages, currents and power levels. Photovoltaic modules, which are the basic building blocks of PV systems, consist of PV cell circuits sealed in an environmentally protective laminate. PV arrays are the complete power generating unit, consisting of any number of modules. Figure 2.1 below shows a simple diagram of PV cell, module and array [2].

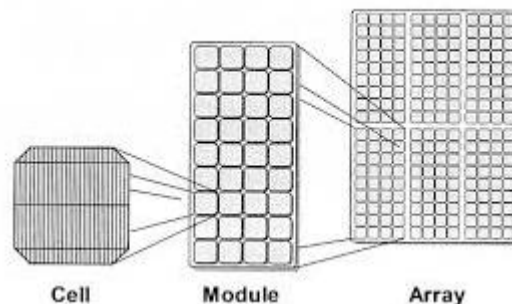

Fig. 2.1 PV Cell, Module and Panel

(Source: DFW Green Building and Renewable Energy Website)

2.1.1 The Photoelectric Process

PV cells work by the photovoltaic effect, the effect that causes voltage to be developed across the junction of two different semiconductor materials when they are exposed to light. When light strikes a PV cell, a portion of it is absorbed within the semiconductor material and knocks electrons loose. This enables an electrical charge to flow freely within the material. The electrons freed by light absorption are forced to flow in a certain direction due to an in-built electric field in PV cells.

By placing metal contacts on the top and bottom of the PV cell, the current generated can be put to work by passing through an external circuit. The current is generated silently with no moving parts and emissions. The cells need no maintenance, apart from keeping the top surface of the module clean for the passage of light [6].

2.1.2 Types of Photovoltaic Technologies

Today various PV technologies exist. The major technologies shall be discussed briefly in the following sections.

2.1.2.1 Monocrystalline Silicon

Monocrystalline silicon cells are usually manufactured from a single crystal ingot of high purity which is usually grown by the Czochralski method. The ingot is cut into thin slices which are then processed to make PV cells. Monocrystalline silicon can also be made by other methods namely edge-defined film-fed growth (EFG) and string ribbon processes. To increase the amount of light absorbed into the cell, which will result in higher currents, a thin anti-reflection (AR) coating is applied as either silicon nitride or titanium oxide [6].

2.1.2.2 Polycrystalline Silicon

The starting material for manufacturing polycrystalline silicon (multi-crystalline silicon) is melted and cast in a cuboid form. As the silicon solidifies, large crystals are formed with grain sizes from a few millimeters to a few centimeters. The ingot is cut into bars and then sliced into thin wafers that are used to make PV cells. Polycrystalline silicon is slightly less expensive and less efficient than mono-crystalline silicon [6].

2.1.2.3 Thin-Film Technologies

Thin-film cells are constructed by depositing extremely thin layers of PV materials onto a superstrate (the front glass) or onto a substrate (the module backside). Connections between the cells are an integral part of the cell fabrication so the PV module is made at the same time. Amorphous Silicon, Copper Indium Diselenide (CIS) and Cadmium Telluride (CdTe) are used as active semiconductor materials.

Compared to silicon based PV cells, thin film cells require less material and energy for their production. Moreover, the module production is highly automated. These factors contribute for considerable cost savings. However, their efficiency is lower than that of crystalline silicon technology. Table 2.1 lists the established PV cell technologies in order of decreasing efficiency [6].

Table 2.1: PV Cell Technologies and Efficiencies

Type	Typical Module Efficiency	Area Requirement
High-performance hybrid silicon (HIT)	17-18%	6-7m ² /kW _p
Monocrystalline silicon	12-15%	7-9m ² /kW _p
Polycrystalline silicon	11-14%	7-10m ² /kW _p
Thin-film CIS	9-11%	9-11m ² /kW _p
Thin-film CdTe	6-8%	12-17m ² /kW _p
Thin-film amorphous silicon	5-7%	14-20m ² /kW _p

2.2 Building Integrated Photovoltaics (BIPV)

In the past few decades, it was learned that the goal of good design should go beyond creating a building that is only aesthetically pleasing and that buildings should be environmentally responsive as well. Rather than merely using less non-renewable fuels and creating less pollution, sustainable buildings that rely on renewable resources to produce some or all of their own energy and create no pollution must be designed. And for this, it is a necessity for buildings to harvest energy from their surroundings. In this regard, one of the most promising renewable energy technologies is Photovoltaics which is a truly elegant means of producing electricity on site directly from the sun without concern for energy supply or environmental harm. These solid-state devices simply make electricity out of sunlight silently with no maintenance, no pollution and no depletion of materials [7].

In building integrated photovoltaic (BIPV) systems, PV modules are architecturally integrated into the building's design and replace parts of the conventional building materials. Hence, BIPV system serves as a building envelope material and power generator simultaneously. Building integration of photovoltaic (PV) cells may be carried out on roofs, facades and shading systems.

Several aspects have to be considered and evaluated related to the integration of the PV cells into the outer building envelope skin. These include location constraints, tilt and orientation, overshadowing, partial Shading, temperature effect, etc. [6].

2.2.1 Types of Building Integrated Photovoltaic Technologies

A wide variety of BIPV systems are available in today's markets including roofing systems and façade systems. Examples of roofing systems are tiles, shingles and skylight and those of façade systems are curtain wall, spandrel and glazing [8]. BIPV systems are basically classified into two namely grid-tied and stand-alone systems [9]. A brief explanation of each system is presented in the following sub-sections.

2.2.1.1 Grid-Tied Systems

These are BIPV systems connected to the public grid. Such systems require an inverter for converting the PV-generated DC electricity to AC electricity at the level of the grid voltage. In such systems, excess electricity generated by the PV system will be fed to the grid and in case of electricity deficit electricity will be drawn from the grid. Policies related to interconnection requirements and reimbursement for PV-generated electricity fed into the grid (feed-in tariff) differs throughout the various nations and regions. There are three types of tariffs currently in practice. The first one supports the production of PV generated power by offering a better price for each kWh fed into the grid as compared with the charge for each kWh drawn from the grid. The second type is a tariff where the same price per kWh is applied for both flow directions. The third one, however, pays less for each kWh of PV power fed into the grid than that of the grid sold to the consumer. Depending on the kind of tariffs, one or two electricity meters have to be used at the point of utility connection. Figure 2.2 shows a simple block diagram of a grid-tied PV system suitable for building integration [9].

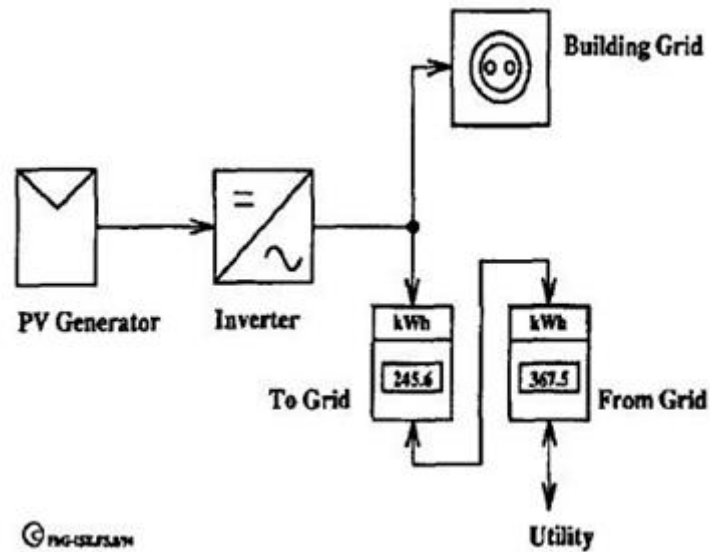

Fig. 2.2: Schematic Diagram of a Grid-Tied PV Power System

(Source: Photovoltaics in Buildings; A Design Handbook for Architects and Engineers)

For grid-connected applications to be feasible, the cost of the photovoltaic systems must compete against the cost of the conventional energy source used to supply the grid. Moreover, PV systems are particularly cost-effective when the utility load and solar resource profiles are well matched. The case in areas with peak electricity loads during the peak sunshine hours of the summer day can be taken as a good example for this [9].

2.2.1.2 Stand-Alone Systems

Stand-alone systems are those systems not connected to the grid system. In such PV systems, a storage battery is needed for use at times of sunshine unavailability. When there are no or low loads, the surplus energy produced charges the battery for use during times of no or low solar radiation. A charge controller, as part of the stand-alone system, plays the role of supervising the charge/discharge process in order to ensure a long battery lifetime. Moreover, an inverter may be used for transforming the DC electricity generated by the PV system to AC for loads with such requirement [9]. A schematic diagram of such a system is shown in Figure 2.3 below.

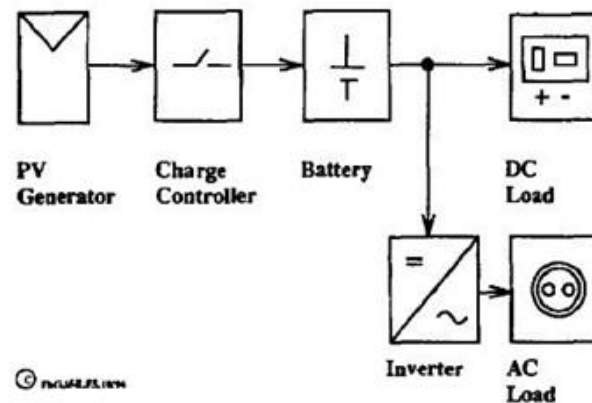

Fig. 2.3: Schematic Diagram of a Stand-Alone PV System

(Source: Photovoltaics in Buildings; A Design Handbook for Architects and Engineers)

PV systems are most effective as stand-alone systems for remote sites off the electrical grid due to their high reliability and low servicing requirements. In such cases, the costs of PV systems compete with that of electricity from the grid or other means of remote electricity supply [9].

2.2.2 Components of Grid-Tied BIPV Systems

The major components of a grid-tied BIPV system are PV modules, Maximum Power Point Tracking (MPPT) systems and inverters. A brief description of each component shall be presented in the following sub-sections.

2.2.2.1 PV Modules

As discussed briefly in sub-section 2.1, a PV module, which is the connection of many cells in series and/or parallel, is the basic unit of any photovoltaic system. The PV module produces DC electricity which needs to be converted to AC for grid-tied applications. Moreover, a module plays a vital role of encapsulation and protection of PV cells from mechanical stress, weathering and humidity. It is only with such lamination that the usual guarantee period of PV cells for 20-25 years can be achieved even in harsh environments.

2.2.2.2 Inverters

A solar (PV) inverter, one of the key components of grid-tied solar PV/BIPV systems, is used to change the DC electricity generated by solar panels into AC electricity which can be utilized by a utility grid. Moreover, solar array inverters are equipped with special components namely maximum power point tracker (MPPT). This feature of inverters automatically adjusts the voltage of PV modules for varying irradiance levels, so that the maximum power output of a PV module can be exploited. Different types of MPPT algorithms are implemented, and three of the main types are perturb-and-observe, incremental conductance and constant voltage. Solar inverters may be classified into three based on their type of application. A brief explanation of each inverter type is presented below.

a) Stand-Alone Inverters

Such inverters are used in isolated/stand-alone systems where the inverter draws DC energy from batteries charged by photovoltaic arrays. Many stand-alone inverters also incorporate integral battery chargers to replenish the battery from an AC source, when available. Normally these do not interface in any way with the utility grid, and as such, are not required to have anti-islanding protection [10].

b) Grid-Tie Inverters

Grid-tie inverters are those types of inverters designed to match phase with a utility-supplied sine wave. Moreover, grid-tie inverters should have an anti-islanding function. This is used to stop the inverter from feeding power to small sections of the grid known as islands in the event of a power failure on the grid. Otherwise, the powered islands may put utility workers at risk. Such inverters do not provide backup power during utility outages [10].

c) Battery Backup Inverters

Battery backup inverters are special inverters which are designed to draw energy from a battery, manage the battery charge via an onboard charger, and export excess energy to the utility grid. These inverters are capable of supplying AC energy to selected loads during a utility outage and are required to have anti-islanding protection [10].

Inverters may also be classified into module/micro, string and solar inverters. A short explanation of each inverter type is shown as follows [11].

a) Module/Micro Inverters

These types of inverters consist of a small box located on the back or very close to each solar panel and are attached directly to individual photovoltaic modules. Module/Micro inverters are exceptionally reliable and highly efficient. However, they can add a substantial cost to a solar project. Micro inverters have the under-listed advantages [11].

- Panel level MPPT
- Increases system availability since a single malfunctioning panel will not have an impact on the entire array
- Panel level monitoring
- Lower DC voltage and hence increased safety
- Allows for increased design flexibility (modules can be oriented in different directions)
- Increased yield from sites that suffer from overshadowing, as one shadowed module doesn't drag down a whole string
- Simpler to design systems
- Ability to use different models of modules in one system, particularly when repairing or updating older systems

On the other hand, micro inverters have the following disadvantages.

- Higher costs
- Increased complexity in installation
- Given their positioning in an installation, some micro-inverters may have issues in extreme heat
- Increased maintenance costs due to there being multiple units in an array

b) String Inverters

String inverters are currently the most widely used inverter types. They are designed to be wired to a single series string of solar modules and are currently the most widely used inverter type. It is a large box and is often situated some distance away from the solar array. Depending on the size of the installation, there may be more than one string inverter present. String inverters have the following advantages [11].

- Allow high design flexibility
- Highly efficient and robust
- Low cost
- Remote system monitoring capabilities

On the other hand, string inverters have the following disadvantages.

- No panel level MPPT
- No panel level monitoring
- Have high voltage levels which may lead to a potential safety hazard

c) Central Inverters

Central inverters can be considered as very large string inverters. Such types of inverters are used in large scale applications such as large arrays installed on buildings, industrial facilities as well as field installations. Central inverters have the under-listed advantages [11].

- Low capital price per watt
- High efficiency
- Comparative ease of installation

On the other hand, central inverters have the following disadvantages.

- Large size
- Have noise
- A single potential point of entire system failure

2.2.3 Types of BIPV Products and Integration Techniques

BIPV products have a wide range of varieties which lead to different ways of categorization. Based on the product descriptions from the manufacturers and the types of material the products are customized to be combined with, BIPV products may be classified as BIPV foil products, BIPV tile products, BIPV module products and Solar cell glazing products[7]. A brief explanation of each product type is given in the following sub-sections.

2.2.3.1 BIPV Foil Products

BIPV foil products are often made from thin-film cells and hence are lightweight and flexible. This makes them beneficial with respect to easy installation and prevailing weight constraints for roofs. Moreover, they have increased efficiency during high temperatures so that they can be used on non-ventilated roof solutions. Though PV foil products have a low fill factor due to both the low efficiency and the large solar cell resistances of thin-film cells, it is possible to vary the degree of inclination of the product to a great extent providing flexible solutions [7]. An example of BIPV foil product is shown in Figure 2.4.



Fig. 2.4 Example of BIPV Foil Product

(Source: Building Integrated Photovoltaics-A State of the Art Review)

2.2.3.2 BIPV Tile Products

BIPV tile products are normally arranged in modules with the appearance and properties of standard roof tiles. With varying cell types and tile shapes, they can substitute a certain number of traditional roof tiles and also enable easy retrofitting of roofs [7]. Figure 2.5 shows an example of a BIPV tile product.

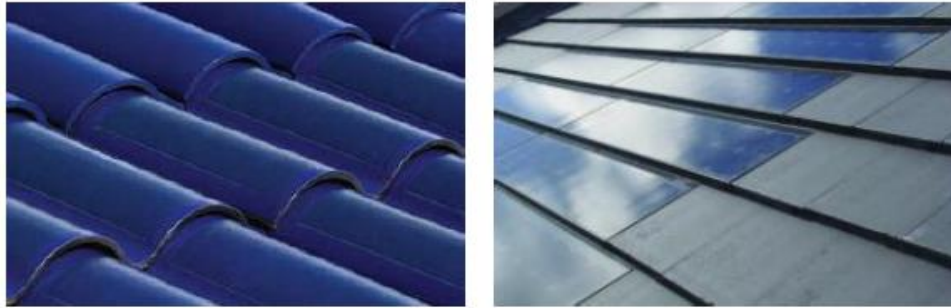

Fig. 2.5 Example of BIPV Tile Product

(Source: Building Integrated Photovoltaics-A State of the Art Review)

2.2.3.3 BIPV Module Products

The BIPV module products are modules which are similar to conventional PV modules but are made with weather skin solutions. Some of the BIPV module products may be used to replace various types of roofing [7]. An example of BIPV module is displayed in Figure 2.6 below.



Fig. 2.6 Example of BIPV Module Product

(Source: Building Integrated Photovoltaics-A State of the Art Review)

2.2.3.4 Solar Cell Glazing Products

Solar cell glazing products, having a variety of colors and transparency levels, make different aesthetically pleasing solutions for windows, glassed or tiled facades and roofs. Such modules transmit daylight and serve as water and sun protection. The transparency level can be adjusted by varying the distance between the solar cells. Moreover, customized products in terms shape, color, cell material, and transparency level are usually offered by different solar cell glazing manufacturers [7]. Figure 2.7 below shows an example of solar cell glazing products.

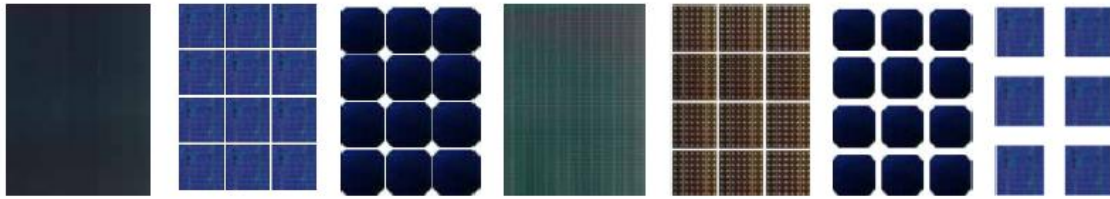

Fig. 2.7 Example of BIPV Solar Cell Glazing Product
(Source: Building Integrated Photovoltaics-A State of the Art Review)

2.2.4 Global Trend in BIPV Technologies

BIPV technology is expected to find tremendous growth opportunities in the construction industry due to the growth of support from government in the form of incentives. In terms of installation, Europe is leading with a growing number of legislations and incentives in favor of BIPV. This is followed by North America and Asia. There is also great opportunity observed in Middle East region for this market. The revenue generated in the overall BIPV market is highest for commercial building while it is the least for industrial buildings. This lesser level of adoption in industrial buildings is gradually growing with increasing number of awareness campaigns and showcase of developments by the market players. On the other hand, the growth of BIPV is still very limited in Africa including Ethiopia [12].

Numerous companies are evolving that support BIPV solutions. Some of the key companies involved in the design, development and supply of BIPV based solutions are Scheuten Solar (The Netherlands), Würth Solar (Germany), Dow Solar (U.S.), and Suntech Power (China).

The global BIPV market is expected to grow from \$4.33 billion in 2009 to \$12.73 billion in 2016 at a CAGR (Compound Annual Growth Rate) of 16.9% from 2011 to 2016. The companies in China and Japan largely adopt strategies such as expansion of production facilities, R&D agreement with universities, undertaking of installation projects and acquisition of certifications in order to achieve tremendous growth in this competitive market. Figure 2.8 below shows the BIPV market revenue from 2010 up to 2016 [12].

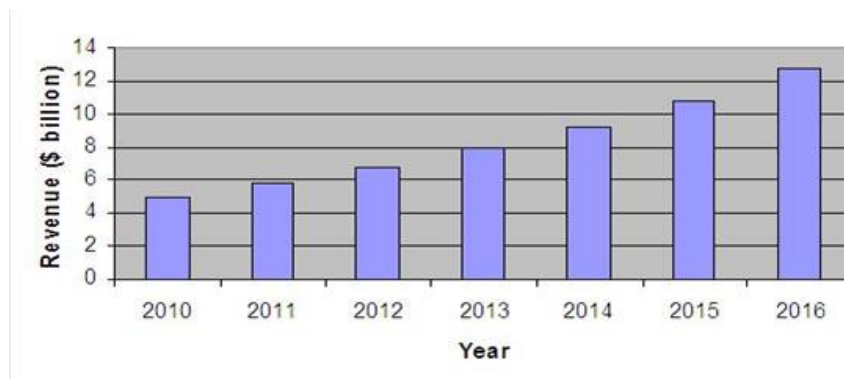

Fig. 2.8 BIPV Market Revenue

Source: Global Building Integrated Photovoltaics (BIPV) Market, By Products, Technologies & Applications (2011 - 2016) By: marketsandmarkets.com, Publishing Date: November 2011, Report Code: SE 1720

The first PV systems were installed in Ethiopia in the mid 1980s for rural home and school lighting. It is estimated that a total of some 5.3MWp of PV is now in use in Ethiopia, the main area of application for PV being off-grid telecom systems (particularly for mobile and landline network stations) which account for 87% of total installations. PV systems are also used in social institutions including health stations, schools and for water pumping. Figure 2.9 shows PV demand estimates in Ethiopia till 2025 [13].

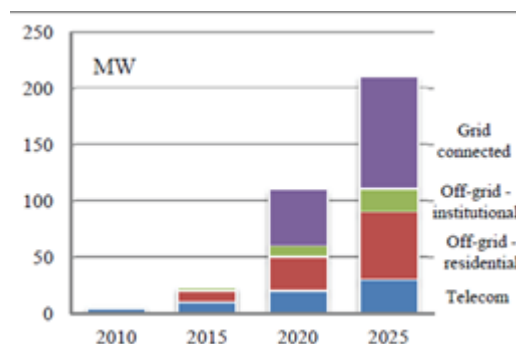

Fig. 2.9 BIPV Demand Estimates in Ethiopia

(Source: Solar Energy Vision for Ethiopia)

2.3 PVsyst Software Overview

PVsyst is a software package developed at the University of Geneva by Andre Meroud. It can be used for the study, sizing and data analysis of complete PV systems including grid-connected, stand-alone, pumping and DC-grid PV systems. It incorporates a database of

meteorological data from various pre-defined stations of Meteonorm and PV systems components. The software currently has reached version 6.2.4 starting from version 2.21 with many improvements at each version [14]. For this study, PVsyst software version 6.2.4 is used. The model implemented by the software and sizing principles will be discussed briefly in the following sub-sections.

2.3.1 PV Module Model Implemented in PVsyst

For the purpose of describing the operation of a PV module, Shockley's simple one diode model primarily developed for a single cell is used. Its generalization to the whole module implies that all cells are considered rigorously identical. The equivalent circuit of the model is as displayed in Figure 2.10 [14].

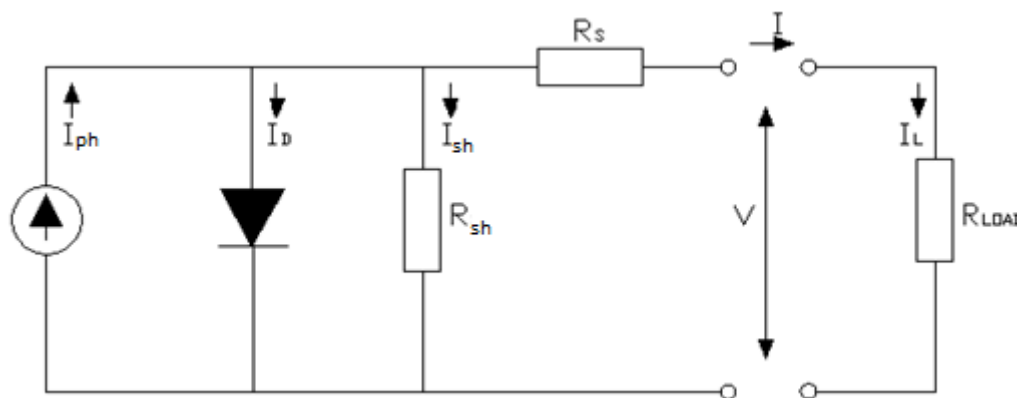

Fig. 2.10 Equivalent Circuit for One Diode Model of a PV cell
(Source: PVsyst Software's User Manual)

The main expression describing the general one-diode model is written as Equation 2.1.

$$I = I_{ph} - I_o [\exp(q(V + IR_s)/(N_{cs} \cdot \gamma \cdot k \cdot T_c)) - 1] - (V + IR_s)/R_{sh} \quad (2.1)$$

where:

I = Current supplied by the module [A]

V = Voltage at the terminals of the module [V]

I_{ph} = Photocurrent [A], proportional to the irradiance G , with a correction as function of T_c (T_c = Effective temperature of the cells [K])

I_D = Diode current ($I_o \cdot [\exp(q(V+IR_s) / (N_{cs} \cdot \text{Gamma} \cdot k \cdot T_c)) - 1]$)

I_0 = Inverse saturation current, depending on the temperature [A]

R_s = Series resistance [Ohm]

R_{sh} = Shunt resistance [Ohm]

q = Charge of the electron = $1.602 \cdot 10^{-19}$ Coulomb

k = Boltzmann's constant = $1.381 \cdot 10^{-23}$ J/K

γ = Diode quality factor, normally between 1 and 2

N_{cs} = Number of cells in series

The IV characteristic of the model is shown in Figure 2.11.

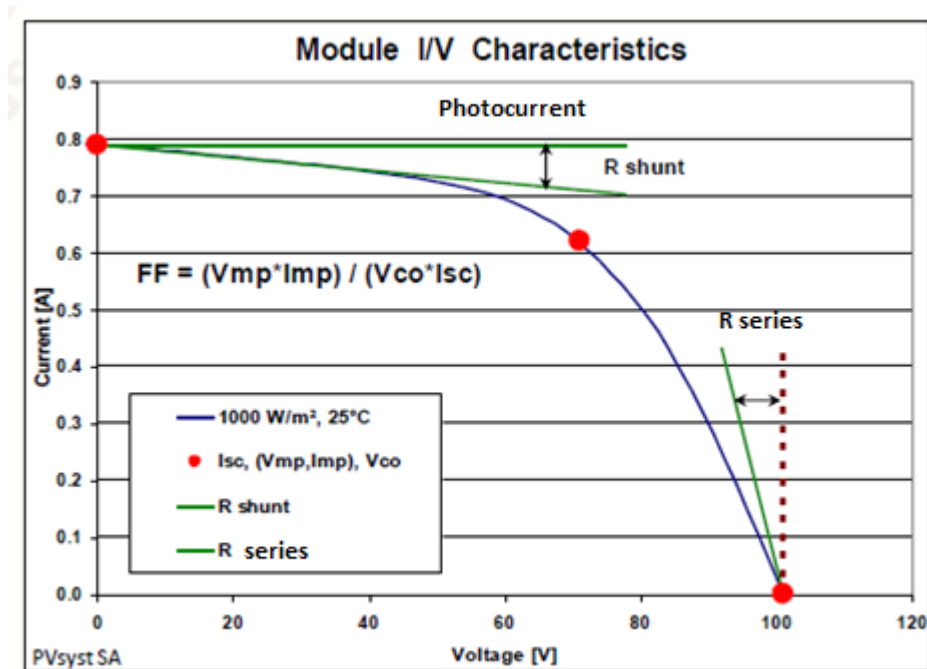

Fig. 2.11 I-V Characteristic of PV Module

(Source: PVsyst Software's User Manual)

2.3.2 Array and Inverter Sizing in PVsyst

Inverter sizing in PVsyst has the following considerations:

1. The nominal power (P_{nom}) of the inverter is defined as the output AC power. The corresponding input power is $P_{nomDC} = P_{nomAC} / \text{Efficiency}$

2. The P_{nom} of the array is defined for Standard Test Conditions (an irradiance of 1000 W/m^2 and temperature of 25°C) which is very rarely or never attained in real conditions.
3. The power distribution is dependent on the plane orientation. For example, a façade will never receive more than $700\text{-}800 \text{ W/m}^2$ depending on latitude.
4. The maximum power is not significantly dependent on latitude but rather on altitude. On clear days and perpendicular to the sun's rays, it is only dependent on the air mass.
5. Many inverters accept a part of overload specified by a P_{max} parameter, during short times (dependent on the temperature of the device). This is not taken into account in the simulation which may reduce the calculated overload loss.
6. When over-sized, the inverter will operate more often in its low power range, with decreased efficiency.

In PVsyst, the inverter sizing is based on an acceptable overload loss during operation, and therefore involves estimations or simulations in the real conditions of the system (meteorological data, orientation and losses) taking the following into account [14].

A. Overload Behavior: With all modern inverters, when the P_{mpp} of the array overcomes its P_{nom} DC limit, the inverter will stay at its safe nominal power by displacing the operating point in the I-V curve of the PV array (towards higher voltages). Therefore, it will not undertake any overpower and there will not be power dissipation, overheating and supplementary aging. But the potential power of the array will not be produced.

B. Loss Evaluation: The energy loss is the difference between the P_{mpp} potential power and the P_{nomDC} limit effectively drawn. The PVsyst criteria for an acceptable sizing are as follows:

- $3\% > \text{Overload Loss} > 0.2\%$ - inverter slightly undersized, warning
- $\text{Overload loss} > 3\%$ - inverter strongly undersized, prevents the simulation

These criteria lead to P_{nom} Ratio (P_{nom} (Array)/ P_{nom} (Inv)) of the order of 1.25 to 1.3 for most well-oriented systems (P_{nom} ratio > 2 for façades). PVsyst also allows modifying these design parameters in order to consider strongly oversized PV arrays.

The next step is the determination of a number of modules in series and a number of strings in order to approach the desired power or available area based on the following requirements [14].

- *The minimum array operating voltage (at maximum module operating temperature, 60°C by default) should be above the minimum inverter's operating voltage (V_{min} of MPPT range).*
- *The maximum array operating voltage (at minimum module operating temperature, 20°C by default) has to stay below the maximum inverter's operating voltage (V_{max} of MPPT range).*
- *The maximum array absolute voltage (V_{oc} at minimum temperature, -10°C by default) has to stay below the absolute maximum inverter's input voltage.*
- *The maximum array absolute voltage (V_{oc} at minimum temperature, -10°C by default) should not overcome the maximum system voltage specified for the PV module.*

2.3.3 System Losses in PVsyst

System losses can be defined as all events which reduce the energy output of a PV array as compared to nominal power stated by the manufacturer for Standard Test Conditions (STC). Several of these loss sources are not directly measurable. In PVsyst, array loss parameters are initially set to reasonable default values, and these values can be defined depending on the PV system to be designed. The factors that diminish the energy output include thermal losses, ohmic losses, module quality losses, light induced degradation losses, array mismatch losses, soiling loss, array incidence loss and unavailability loss [14].

Chapter 3

Materials and Methods

3.1 Design Steps of Building Integrated Photovoltaic (BIPV) System

The design process of a Building Integrated Photovoltaic System starts by assessing the applicability of PV for electricity production. This involves screening the site and the building in question in order to evaluate solar availability of the region and the building. Following this, load analysis shall be made in order to improve the electricity utilization efficiency of the building and to get the basis for the PV system sizing. Finally, selection of components and detailed system sizing can be performed. General matters including utility interface and interconnection issues, land use and construction regulations, safety, etc. that affect the PV system should also be considered during the system design. The diagrammatic description of the design process is shown in Figure 3.1 [9].

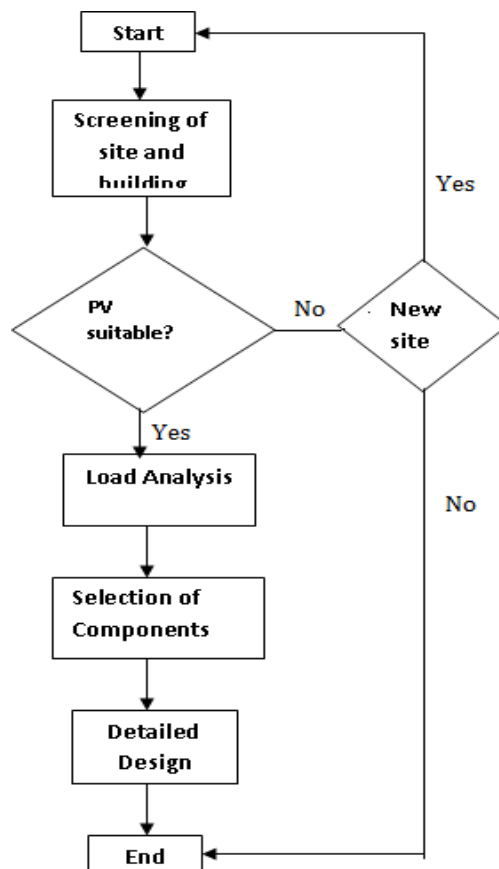

Fig. 3.1 Design Process of a BIPV System

(Source: Photovoltaics in Buildings; A Design Handbook for Architects and Engineers)

The details of each design step and the various considerations and assumptions made for the BIPV system of Zemen Bank Headquarter Building are described in the following sub-sections.

3.1.1 Screening the Application Site and the Building

Zemen Bank Headquarter is a thirty storey building having five basements. It is going to be constructed around Sengatera area of Addis Ababa at $9^{\circ}2'N$ latitude and $38^{\circ}45'E$ longitude. The building is designed by Jdaw Consulting Architects. The 3D design of the building is as displayed in Figure 3.2 and see Appendix for the detailed drawings.



Fig.3.2 Zemen Bank Headquarter Building

The general site aspects affecting the system design and the amount and value of the energy to be produced are the actual location of the system, available array area, solar access to the considered PV array surface and the energy efficiency of the building.

Accordingly, the corresponding data were obtained after investigation of the site area and the design of the building under consideration. The levels of solar access of the various parts of the building throughout the year were carefully examined in order to identify those parts with high solar radiation. The observations made after the examination are shown in Table 3.1.

Table 3.1 Solar Access of Parts of the Building

Season	Sun's Position	Front Facade	Back Facade	Rooftop of Building	Podium of Building¹
Summer (June 21- Sept. 22)	23.5°N (Cancer)	Morning & afternoon	Afternoon	Morning & afternoon	Morning & afternoon
Fall (Sep. 22-Dec. 21)	Equator	Morning	Morning & afternoon	Morning & afternoon	Morning & afternoon
Winter (Dec. 21-Mar. 20)	23.5°S (Capricorn)	Morning	Morning & afternoon	Morning & afternoon	Morning & afternoon
Spring (Mar. 20-June 21)	Equator	Morning	Morning & afternoon	Morning & afternoon	Morning & afternoon

As can be seen from Table 3.1, parts of the building with high solar access are the back facade facing south east, the rooftop and the podium of the building.

3.1.2 Tilt and Orientation of Building Surfaces

The amount of light reaching the surfaces that will incorporate PV arrays is significantly affected by tilt and orientation of the surfaces. Irradiance which is the amount of light incident on a surface at one point in time is a combination of direct and diffuse irradiance. Direct irradiance is dependent on the sun's position and the sun's path tracing a range of angles throughout the day and year. Diffuse irradiance arrives at a surface from clouds. Insolation is the total amount of light energy received at a particular angle over a period of time. For the northern hemisphere, the maximum annual PV output corresponds to a south orientation and a tilt from the horizontal equal to the latitude of the site. [6]

As explained in sub-section 3.1.1, the possible areas for PV integration into Zemen Bank HQ Building are the south east facing façade, the rooftop and the podium.

¹ Only 50% of the total available podium area has access to solar radiation. The rest will be shaded by the building itself.

The corresponding azimuth (the angle between south and collector plane) and tilt are as shown in Table 3.2.

Table 3.2 Orientation and Tilt of Parts of the Building Suitable for PV Integration

Description	Façade	Rooftop	Podium
Plane tilt	It is a curved façade with variable tilt angles ranging from 67° to 90°	10°	10°
Azimuth	-68° ²	-68°	-68°

As can be seen from Table 3.2, the value of the minimum tilt angle of the façade is 67° which is much higher than the latitude of Addis Ababa. And this is believed to significantly reduce the annual energy output of the BIPV system. On the other hand, the rooftop and the podium surfaces have tilt angles almost equivalent to the latitude of Addis Ababa. This shows that the podium and the rooftop surfaces are the best options for PV integration. However, in order to have understanding of all the possibilities of PV integration and the differences of each scenario from the optimum, different scenarios of PV integration including the façade surface shall be considered.

3.1.3 Overshadowing

One of the most important factors which influence the efficiency of PV systems is overshadowing. Hence, it is a necessity to examine a particular building for overshadowing due to neighboring buildings, trees and distant tall buildings. Shading which may occur due to the growth of trees over the years should also be taken into consideration [6].

Currently, there are no shadings near Zemen Bank Headquarter Building which can affect the performance of the building. There might be a possibility of construction of condominiums in the vicinity of the building in the future. However, for this particular study, it is assumed that there will not be shadings in the future.

² In the Northern hemisphere, the plane azimuth is defined as the angle between South and collector plane. This angle is taken as negative toward east, i.e. goes in the anti-trigonometric direction. Example: south plane, azimuth = 0, east plane, azimuth = -90°.

3.1.4 Partial Shading

The uniform illumination of solar cells is a necessity for high energy output. As stated in sub-section 3.1.3, it is clear that overshadowing reduces PV output. However, even partial shading from a tree branch, overhead cables running over the building or other things which might appear quite minor can reduce the electricity output significantly.

The charge carriers which enable PV material to conduct electricity are only present in PV material when it is illuminated. Hence, the shading of one cell stops current generation causing the cell to become an electrical resistor [6]. In this study, an assumption was made that there would be no partial shading of PV modules [6].

3.1.5 Zoning a PV Array

The integration of PV modules may sometimes be done on surfaces with different tilt and orientation which leads to the receipt of different levels of irradiance. Connecting modules of such surfaces in one series string would hold back the full generating potential of the modules that are receiving a higher irradiance since the resulting current would be determined by the minimum, this being from the modules receiving least irradiance. In such cases, it would be a necessity to divide arrays into different zones, each zone composing arrays with the same tilt and orientation [6].

As stated in sub-section 3.1.1, parts of Zemen Bank Headquarter Building suitable for PV integration are the south east facing façade, the rooftop and the podium. The podium and rooftop have the same tilt and orientation while the façade has a different tilt. Hence, it is decided to divide the PV arrays into two zones, one for the façade and the other for the rooftop and podium.

3.1.6 Temperature Effect

The efficiency of PV technologies is significantly dependent on temperature. As module temperature increases, the efficiency of PV cells decreases. PV modules convert only 10-15% of the solar energy into electricity and hence the vast majority of the incident energy is converted into heat. The efficiency of crystalline silicon cells decreases by 0.4% for every degree rise in temperature. For amorphous silicon cells, the effect is dependent on specific production process and is estimated to be half this amount.

The temperature difference between PV and ambient depends on irradiation intensity and can climb up to 40°C [6]. In summer, the average daily high temperature of Addis Ababa may reach up to 28°C. Hence, the PV temperature can rise to a temperature of about 60°C.

To avoid this rise of temperature, the integration of PV arrays should be performed in such a way that heat can be well dissipated. In order to allow cooling of PV laminate by natural convection, it is recommended to create an air gap between the PV and the building structure behind.

Table 3.3 shows some indicative values of power reduction for crystalline silicon modules in various roof mountings, as compared to the power output of a completely freestanding array which would be just 22°C warmer than ambient:

Table 3.3 Power Reduction for Crystalline Silicon Modules for Various Mounting Types

(Source: Building Integrated Photovoltaics/A Handbook)

Roof Mounting		Vertical Façade	
Type	Power Reduction (%)	Type	Power Reduction (%)
With a large gap	1.8(28°C warmer)	With good ventilation	3.9(35°C warmer)
With good ventilation	2.1(29°C warmer)	With poor ventilation	4.8(39°C warmer)
With poor ventilation	2.6(32°C warmer)	With no ventilation	8.9(55°C warmer)
With no ventilation	5.4(43°C warmer)		

Therefore, it can be deduced that large air gaps or good ventilation systems are a necessity for a good power output of the BIPV. In this design, it is assumed that ventilated roof, podium and façade systems with natural ventilation are used.

3.1.7 Daily Insolation

The electrical output of a PV system depends on the amount of solar energy received at the location. Daily insolation varies throughout the year, increasing with day length and altitude of the sun. Insolation also depends on weather conditions and cloud pattern of the area. Figure 3.3 shows a map of annual average daily insolation on a horizontal plane for all parts of the world.

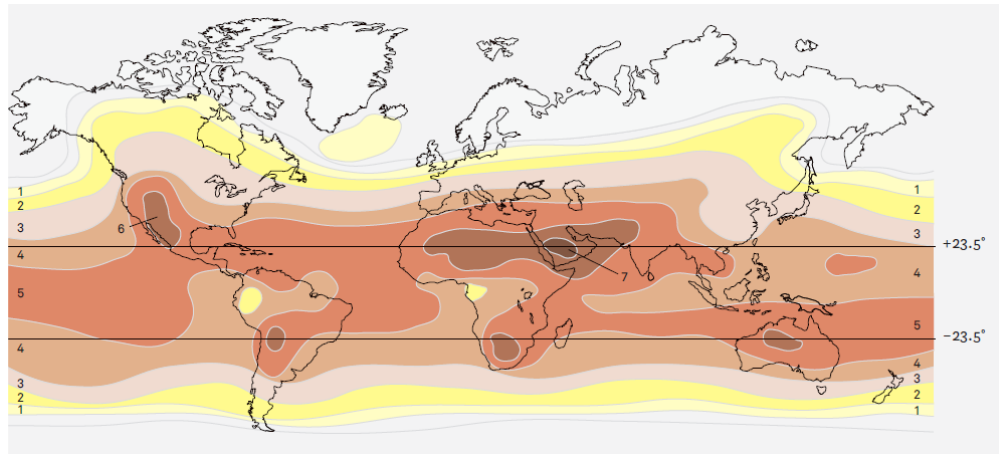

Fig. 3.3 Annual average of daily insolation on a horizontal plane (tilt=0°) across the world³

	kWh/m ² .y	MJ/m ² .y
kWh/m ² .day		
1	365	1.3
2	730	2.6
3	1095	3.9
4	1460	5.3
5	1825	6.6
6	2190	7.9
7	2555	9.2

(Source: Building Integrated Photovoltaics/A Handbook)

It can easily be observed that Ethiopia is one of the countries with high average daily global horizontal solar radiation (5.2 kWh/m²) making it a suitable area for BIPV applications.

Based on the facts stated in the above sub-sections, it can be concluded that the building is suitable for BIPV application. The rest of the design steps are explained in the following sub-sections.

3.2 Load Analysis

After verifying the suitability of the building for PV integration, the next step was estimation of electrical load. Load analysis is an important step since the sizing of the BIPV system components is dependent on electricity demand. Hence, it helps to avoid increased system costs due to oversized systems.

³ This data is taken from many years of climatic data and represent a typical year.

In order to estimate the annual energy consumption of Zemen Bank Headquarter Building, the following relevant data were collected from the Architectural Design Office.

- All floors are dedicated to offices with the exception of the 29th and 30th floors which are going to be used for cafeterias.
- The shape of the façade of the building is curved and hence every floor has variable surface area. The 16th floor is 939.5m² wide and has the largest surface area. The 29th and 30th floors have the least area of 410m². All the floors have a circulation area of 251 m². The area of the basement floors (parking lots) is 1800 m².
- The numbers of desks which can be placed are 74 and 28 for the maximum and minimum floor areas, respectively.

The energy consumers which have been considered for the load analysis of the building are the following:

- Light bulbs
- Computers, printers and scanners
- Photocopy and fax machines
- Server computers, telecom and computer network equipment
- Stove, blenders, dish washer and all other possible kitchen appliances
- Boiler
- Booster pump
- Elevator

The calculations and assumptions made in order to estimate the electricity consumption of the building are described below.

Lighting

The lumen method calculation (Equation 3.1) is used for estimating the number of lumps needed for the building.

$$N = \frac{E \times A}{F \times UF \times MF} \quad (3.1)$$

where:

N = Number of lamps required

E = Illuminance Level Required (lux)

A = Area at working plane height

F = Average luminous flux from each lump

UF = Utilization factor, an allowance for the light distribution of luminaries and the room surfaces

MF = Maintenance factor, an allowance for light output because of deterioration and dirt

Separate calculations were made for indoor lighting (offices and cafeterias) and outdoor lightings considering the different illuminance level requirements. For indoor lighting, the area used in the calculation is the average of the maximum and minimum floor areas. This gives an area of approximately 674.75m^2 . An energy efficient T5 PHILIPS fluorescent lamp with a power of 21W and a flux of 1925 lum was selected [15]. The illuminance level was taken to be 400 lux which is the usual requirement for office areas. Both utilization and maintenance factors (UF and MF) were assumed to be 0.8. Substituting all the relevant values in Equation 3.1 gives the following:

$$N = \frac{400 \times 674.75}{1925 \times 0.8 \times 0.8} = 219$$

Hence, the total number of lumps for the thirty floors will be as follows. In order to take into consideration the circulation areas which have less illuminance level requirement, the total number is multiplied by 0.8.

$$N = 219 \times 30 \times 0.8 = 5256$$

The total power consumption of the lumps in the office areas is as follows:

$$P_{\text{tot}} = N \times P \quad (3.2)$$

where: P = Power of each lump

$$P_{\text{tot}} = 5256 \times 21\text{W} = 110,376\text{W}$$

The energy consumption per year (E) assuming four hours operation per day is calculated from Equation 3.3 as follows:

$$\mathbf{E = P \times \text{hours/day} \times \text{days/year} \quad (3.3)}$$

$$\mathbf{E = 110.376kW \times 4\text{hrs/day} \times 365\text{days/year}}$$

$$\mathbf{E = 161,148.96 \text{ kWh/year}}$$

For the parking lot, the area was taken to be 1800 m². A T5 PHILIPS fluorescent lamp with a power of 35W and a flux of 3325 lum was selected. The illuminance level was assumed to be 100 lux which is the usual requirement for parking areas [15]. In this case also, a value of 0.8 was taken for both utilization and maintenance factors (UF and MF). Hence, the number of lumps for one basement was found to be:

$$\mathbf{N = \frac{100 \times 1800}{3325 \times 0.8 \times 0.8} \cong 85}$$

For the five basements dedicated for parking, the total number of lumps will be as follows:

$$\mathbf{N = 85 \times 5 = 425}$$

The total power consumption is, therefore, the total number of lumps multiplied by the power of each lump and is calculated as follows:

$$\mathbf{P_{\text{tot}} = 425 \times 35W = 14,875W}$$

The energy consumption, per year assuming sixteen hours operation is as follows:

$$\mathbf{E = 14.875kW \times 16\text{hrs/day} \times 365\text{days/year}}$$

$$\mathbf{E = 86,870 \text{ kWh/year}}$$

The building has no compound. Hence, two outdoor lighting points were considered. For this, standard metal halide lamp with a power of 150W and luminous flux of 8413 was selected [16]. The total power consumption is, therefore, the total number of lumps multiplied by the power of each lump and is calculated as follows:

$$\mathbf{P_{\text{tot}} = 2 \times 150W = 300W}$$

The energy consumption per year assuming sixteen hours operation is as follows:

$$E = 0.3\text{kW} \times 16\text{hrs/day} \times 365\text{days/year}$$

$$E = 1,752\text{kWh/year}$$

Hence, the total yearly load for lighting will be:

$$E_{\text{tot}} = E_{\text{off}} + E_{\text{par}} + E_{\text{outdoor}}$$

$$E_{\text{tot}} = 161,148.96 + 86,870 + 1,752 = 249,770.96\text{kWh/year}$$

Cafeteria Appliances

For the cafeteria, an energy consumption of 0.4725 kWh/m²/year was taken in order to calculate the yearly load of the two cafeterias. This value is the energy consumption of NREL's state-of-the-art cafeteria which is certified to the U.S. Green Building Council's Leadership in Energy and Environmental Design (LEED) Platinum-level rating, and uses about 25% less energy than a cafeteria built to current commercial code [17].

The total area of the two cafeterias on the 29th and 30th floors of the building is 820 m². Hence, the total estimated value of the cafeterias is calculated as follows by considering an error factor of 0.7:

$$E_{\text{caf}} = \frac{0.4725\text{kWh}}{\text{m}^2} / \text{year} \times 820\text{m}^2 \times 0.7$$

$$E_{\text{caf}} = 271.2\text{kWh/year}$$

Office Appliances

Based on the floor data of the building, the maximum numbers of desks that the floors with the largest and smallest area can accommodate are 75 and 25 office desks, respectively. Hence, an average of 50 desks was assumed on each floor of the building. Since two of the floors are dedicated for cafeteria and one floor for conference rooms, it is assumed that 50 computers are available on 27 floors. The load estimation of office appliances is shown in Table 3.4.

Table 3.4 Load Estimation of Office Appliances [18]

Appliance	Equipment Typical Power Requirements [W]	No.	Duty Cycle [Hrs per day]	Duty Cycle [Hrs per year]	Energy Consumption [kWh/year]
Computer	55	1350	12	4380	325,215.00
Monitor (15")	35	1350	12	4380	206,955.00
Laser Printer	60	135	5	1825	14,782.50
Fax Machine	35	135	2	730	3,449.25
Copier (Small)	115	130	0.5	182.5	2,728.38
Copier (Large)	310	5	0.5	182.5	282.88
Scanner	36	30	0.25	91.25	98550
Server Computers, Telecom & Computer Network Equipment	-	-	-	-	115,052.3 ⁴
Total	646	3109	32.25	11,771.25	767,015.31

Booster Pumping System

For the booster pumping system, the yearly energy consumption of a twenty six floor high rise residential building located in the city of Toronto as reported by Minto Energy Management in cooperation with city of Toronto and Canada Mortgage and Housing Corporation (CMHC) was taken as a reference [19]. According to the documents, the daily energy consumption is 108 kWh. Hence, by multiplying it with the number of days per year (365) a total energy consumption of 39,420 kWh/year was estimated.

Closed-Circuit Television (CCTV)

The energy consumption of the Closed-Circuit Television (CCTV) cameras was taken from Connexed Surveillance Service (CSS) website [20] which offers energy efficient CCTV cameras. According to the website, the total yearly energy consumption for ten cameras is 6500 kWh/year. Assuming thirty five cameras for Zemen Bank Headquarter Building yields a total energy consumption of 227,500 kWh/year.

⁴ It is taken to be 15% of the total electricity consumption of the office equipment [32]

Elevator

For the elevator, the energy consumption of MiniSpace elevator manufactured by KONE is used. KONE is one of the largest manufacturers of elevators and escalators worldwide [21]. The calculation for the energy estimation was done based on an elevator speed of 2.5 m/s, a load of 1000 kg, 400,000 starts/year, 1000 running hours, a travel height of 99 m and 33 floors [22]. The graphical representation of the various technologies is displayed below in Figure 3.4. Hence, the energy consumption of the new KONE MiniSpace with energy saving options which is approximately 6000 kWh/year was taken for the load analysis of Zemen Bank Headquarter Building.

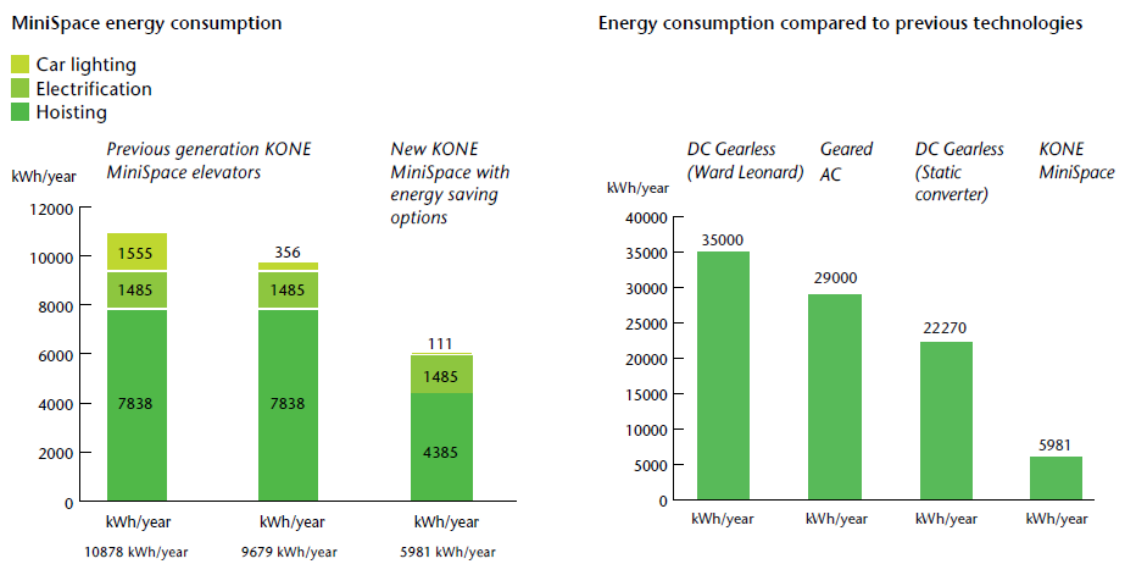

Fig. 3.4 Energy Consumption of Various Elevator Technologies

Based on the above calculations, the total yearly load of Zemen Bank HQ Building is summarized as shown in Table 3.5.

Table 3.5 Estimated Yearly Load Requirement

No.	Load Description	Yearly Load [kWh/year]
1	Light Bulbs	249,770.96
2	Office Appliances	767,015.31
3	Cafeteria	271.22
4	Closed-Circuit Television (CCTV) cameras	227,500
5	Elevator	6,000
6	Booster Pump	39,420
Total Yearly Load of the Building		1,289,977.49

3.3 Input Data Used for Simulation by PVsyst Software

PVsyst software offers two levels of PV system study, namely preliminary design and project design. The preliminary design is a pre-sizing step by performing system yield evaluation using monthly meteorological data and few general system parameters without specifying actual system components. In this study, only the project design step is used since the preliminary design provides a rough estimation of the system yield and cost.

In the design process, the following four scenarios were considered and the percentage difference from the optimum was analyzed:

- Using the actual data of the façade, the rooftop and the podium surfaces of the building;
- Using the same surfaces but assuming a constant tilt angle of 60° throughout the façade rather than the actual curved shape with varying tilt angles;
- Assuming a tilt angle of 10° but having the same total area (façade, rooftop and podium) as the first and second scenarios so that it can be used as a reference for comparison with the first two scenarios; and
- Using only the rooftop and the podium surface areas which are already designed to be at the optimum tilt angle of 10°.

The first user interface which appears when opening PVsyst software is shown in Figure 3.5. From the various options available, project design of grid-connected system was selected for the study.



Fig 3.5 First User-Interface of PVsyst Software

3.3.1 Project Designation

The first step of the project design is the project designation which includes the definition of geographic site, the associated meteorological hourly data and the albedo settings. The dialog box used for specifying the project designation is shown in Figure 3.6.

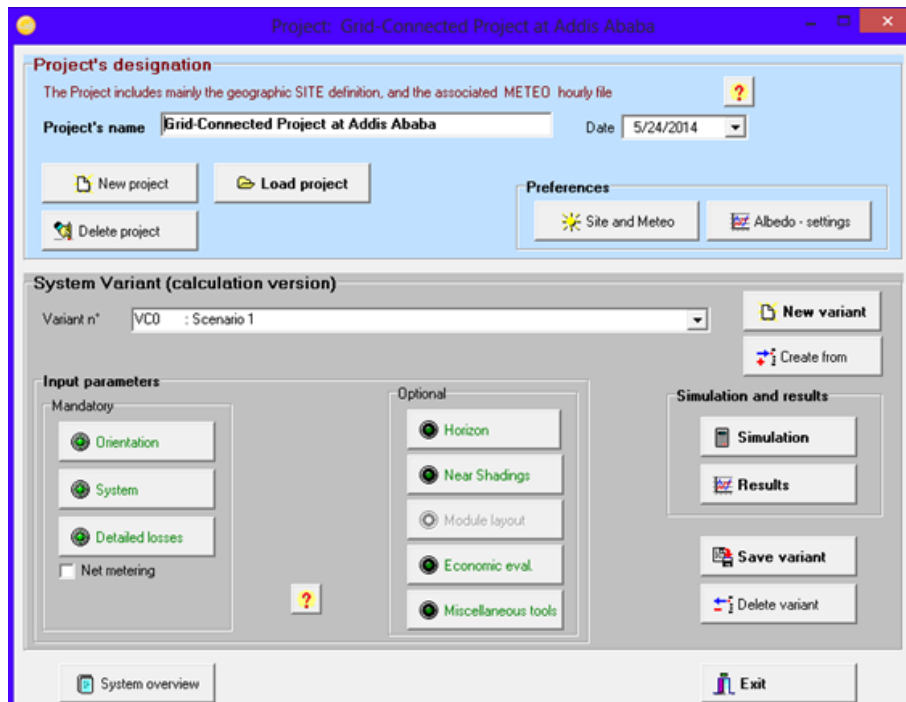

Fig 3.6 Project's Designation Dialog Box

3.3.1.1 Definition of Geographic Site

The regional location and geographical coordinates of the project site were entered as shown in Figure 3.7. The project site is located at Addis Ababa 9°2' latitude and 38°45'

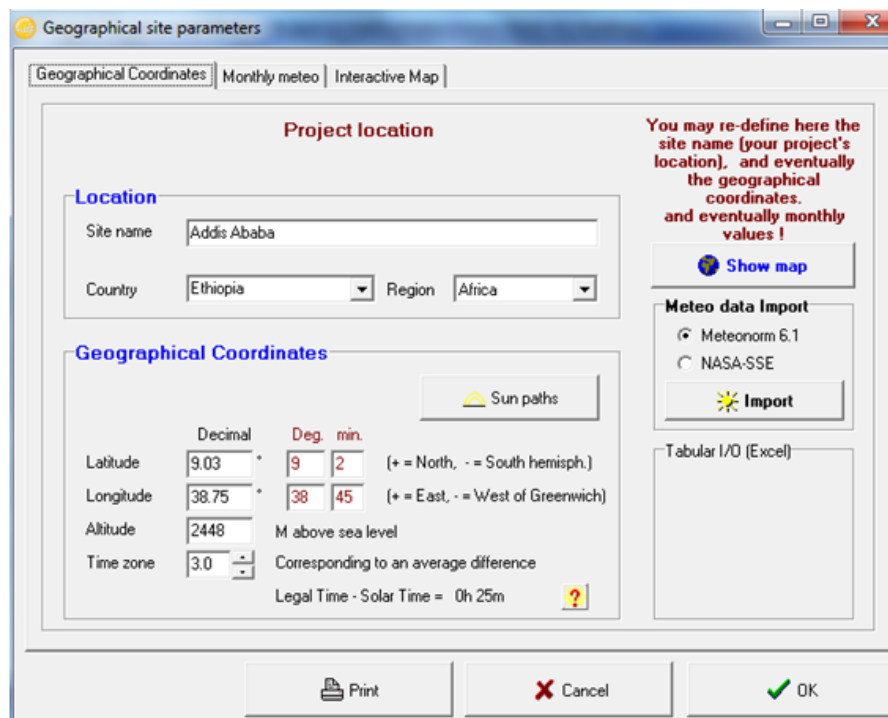
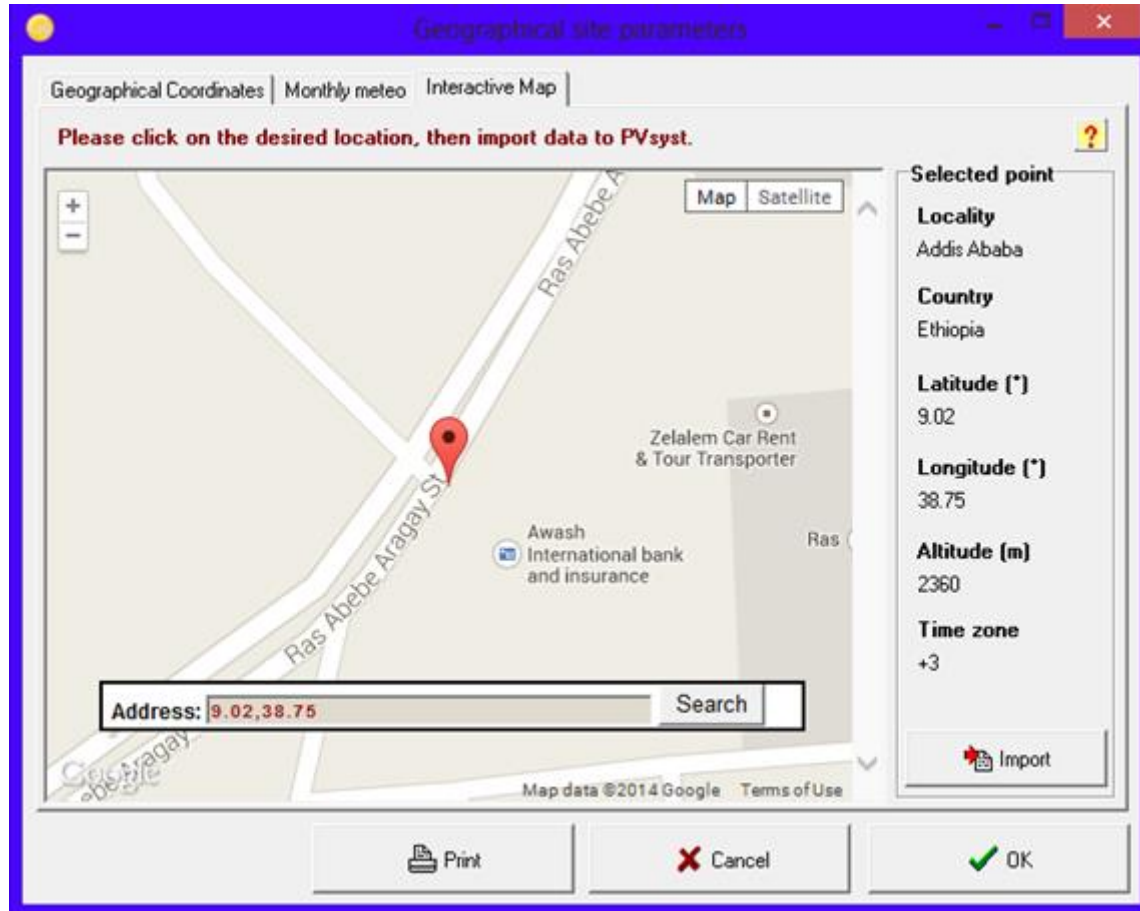

Fig.3.7 Project Location and Geographical Coordinates

Figure 3.8 shows a map of the place where the building is going to be constructed.

**Fig.3.8 Map Showing the Place of Construction**

3.3.1.2 Meteorological Data

The detailed simulation process requires meteorological hourly data of horizontal global irradiance and ambient temperature. It is possible to get meteorological data using the Meteonorm database in the "Geographical Site Parameters" dialog box, import data from meteorological data sources or create files from measured data. PVsyst also offers a feature for generating synthetic hourly meteorological data from monthly data of the project's site. For this study, monthly data of global irradiance, diffuse irradiance and ambient temperature were imported from NASA-SEE. Then, a synthetic hourly file was generated by PVsyst software from the imported data. The monthly data of the software is as shown in Figure 3.9.

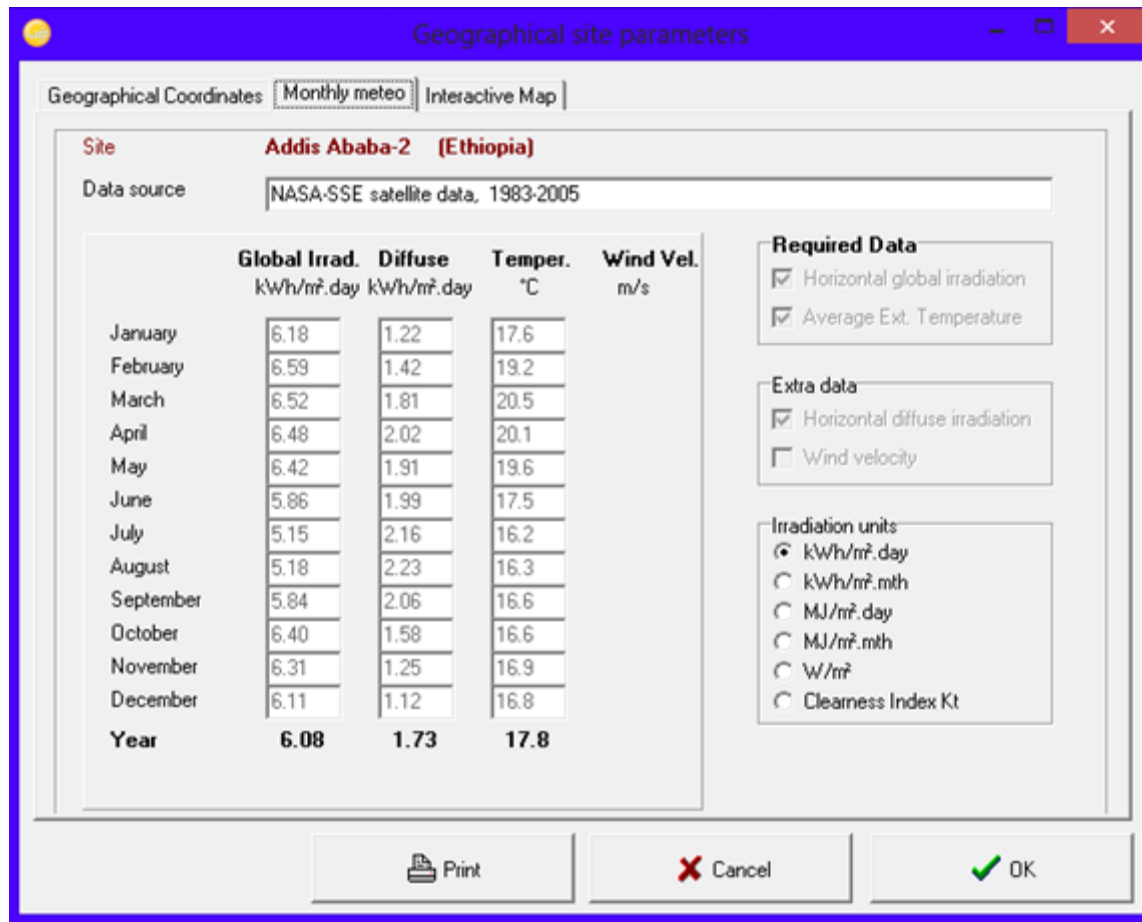

Fig 3.9 Monthly Meteorological Data of Addis Ababa

3.3.1.3 Albedo Settings

The definition of the albedo settings includes specifying albedo coefficient, design conditions and other limitations. Each parameter is discussed briefly as follows.

Albedo Coefficient: is the fraction of global incident irradiation reflected by the ground in front of a tilted plane. This effect takes place during the transposition computation of the horizontal irradiation onto a tilted plane. The albedo seen by the plane is null for a horizontal plane and increases with tilt. Its contribution is proportional to $(1 - \cos i) / 2$, where i = plane tilt. The best value for a given situation may also be obtained by a direct measurement on the site [14].

The albedo coefficient can be adjusted for each month in order to take in to consideration the changes of weather conditions throughout the year. The value usually taken for urban areas is of the order of 0.14 to 0.22. For this particular study, the default value of the software (0.2) is taken throughout the year as shown in Figure 3.10.

Project's parameter: Albedo for the project's situation

Albedo | Design conditions | Other limitations

Albedo values ?

Monthly values

Jan.	0.20	July	0.20
Feb.	0.20	Aug.	0.20
Mar.	0.20	Sep.	0.20
Apr.	0.20	Oct.	0.20
May	0.20	Nov.	0.20
June	0.20	Dec.	0.20

Set a common value

Common value

(Default: albedo = 0.2)

Set

Usual values for albedo

Urban situation	0.14 - 0.22
Grass	0.15 - 0.25
Fresh Grass	0.26
Fresh snow	0.82
Wet snow	0.55 - 0.75
Dry asphalt	0.09 - 0.15
Wet asphalt	0.18
Concrete	0.25 - 0.35
Red tiles	0.33
Aluminium	0.85
New galvanised steel	0.35
Very dirty galvanised steel	0.08

Cancel OK

Fig 3.10 Albedo Monthly Values

Design Conditions: The definition of design conditions refers to the specification of design temperatures. In order to give a reasonable value for each temperature, the average maximum and minimum temperatures of Addis Ababa were used. These values were taken after comparing the data obtained from two different sources. The first data was obtained from World Weather and Climate Information and is shown in Figure 3.11.

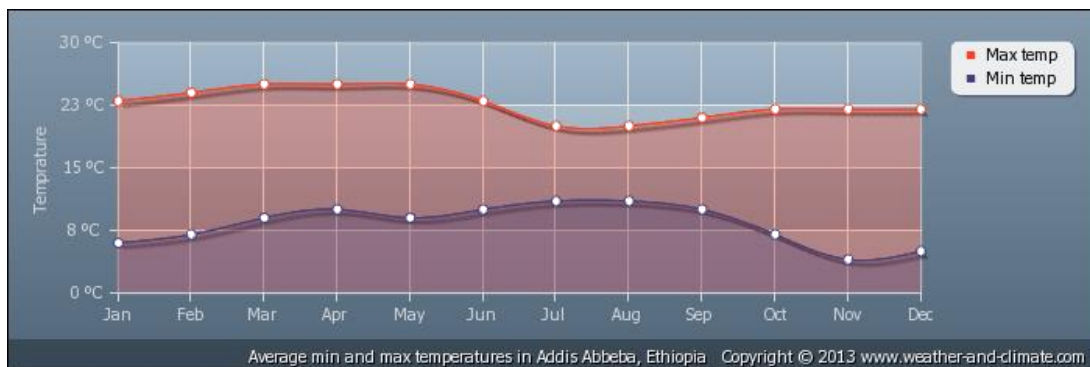

Fig 3.11 Average Maximum and Minimum Temperatures of Addis Ababa (Source: World Weather and Climate Information)

The second data was obtained from World Weather Information Service and the daily minimum and maximum values for each month of the year are shown in Table 3.6.

Table 3.6 Daily Minimum and Maximum Mean Temperatures of Addis Ababa

Month	Mean Temperature	
	Daily Minimum	Daily Maximum
January	8	24
February	9	24
March	10	25
April	11	24
May	11	25
June	10	23
July	10	21
August	10	21
September	10	22
October	9	23
November	7	23
December	7	23
Average	9	23

Climatological information is based on monthly averages for the 30-year period 1981-2010

(Source: World Weather Information Service)

Using the above data, the following design temperatures were defined.

Lower temperature for absolute voltage limit: This is the absolute cell lower temperature for determining the maximum possible voltage of the array. Ideally, it should be the minimum temperature ever measured during daylight at the site under consideration. The default value is -10°C [14]. For this study a value of 7°C was taken considering the lowest mean temperature of Addis Ababa.

Winter operating temperature for V_{mpp} design: This is defined as the winter minimum cell temperature in operating conditions. The default value is 20°C [14]. In operating conditions the temperature of building integrated PV modules may

rise by 20-40°C than the ambient temperature. For this study, a value of 35°C was taken considering the average winter temperature of Addis Ababa which is 15 °C and a rise of 20 °C during operation.

Usual operating temperature: This is defined as the summer usual operating conditions. The average daily temperature of Addis Ababa is 16°C. In operating conditions the temperature of building integrated PV modules may rise by 20-40°C than the ambient temperature. Hence, a value of 50°C was taken for this study.

Summer operating temperature for V_{mppmin} design: This is the maximum cell temperature in operating conditions [14]. The maximum average temperature of Addis Ababa is 25°C. By considering a 35°C rise in temperature of PV cells, a value of 60°C was taken for the study.

The other parameters defined in the albedo setting are as follows.

Array maximum voltage: It is defined as the maximum admissible array voltage (V_{oc} at minimum temperature) specified with PV modules. It is 1000V as per IEC standard.

Temperature coefficient of the open circuit voltage (μV_{oc}): It is calculated by the one-diode model which allows the use of a derate factor μV_{oc} specified by the manufacturer.

Limit overload loss for design: This parameter is used to limit the loss due to oversized PV array with respect to the inverter. For this study, the minimum value of 3% was used [14].

All the aforementioned parameters were defined in the dialog box shown in Figure 3.12.

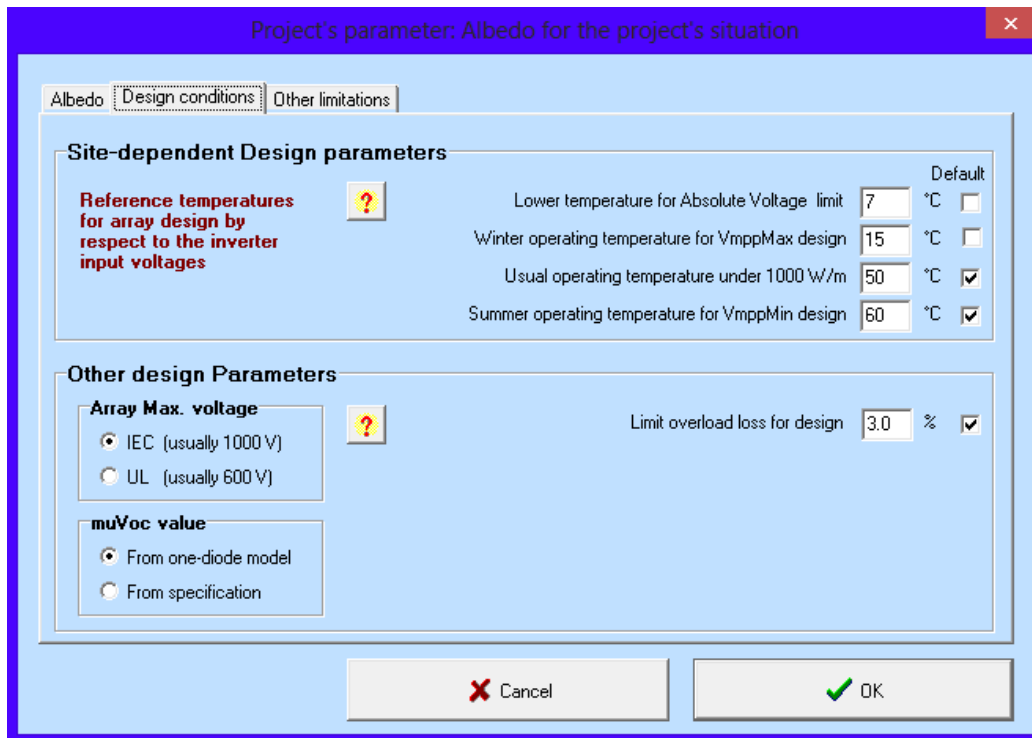

Fig. 3.12 Definition of Design Parameters

Other Limitations: This option is used for 3D shading analysis. Since the 3D shading analysis is not part of this study, the definition of these parameters was not performed.

3.3.2 Input Parameters for the Four Scenarios

As stated in sub-section 3.3, the simulation was done for four different scenarios and hence four different system variants/calculation versions were performed.

3.3.2.1 Orientation

This refers to the orientation of parts of the building to be used for PV integration and includes the definition of the plane tilt and azimuth. PVSyst supports simulations with many plane orientation modes including fixed tilted plane, several orientations, tracking two axes, seasonal tilt adjustment, tracking horizontal axis N-S, etc. The orientations used for each scenario is displayed in Table 3.7. Several orientations were used for the first two scenarios since the BIPV system has two separate zones, one for the rooftop and podium and the other for the façade.

Table 3.7 Orientations Implemented for Each Scenario

Scenario	Orientation Mode of PVsyst	Azimuth	Tilt Angle
First	Several Orientations	79°	-68°
		10°	-68°
Second	Several Orientations	60°	-68°
		10°	-68°
Third	Fixed	10°	-68°
Fourth	Fixed	10°	-68°

The plane tilt is the angle between the horizontal and the collector plane. Azimuth is defined as the angle between south and collector plane in the northern hemisphere. The angle is taken as negative towards east. The input data for scenario one .i.e. using the actual data is as shown in Figures 3.13 and 3.14.

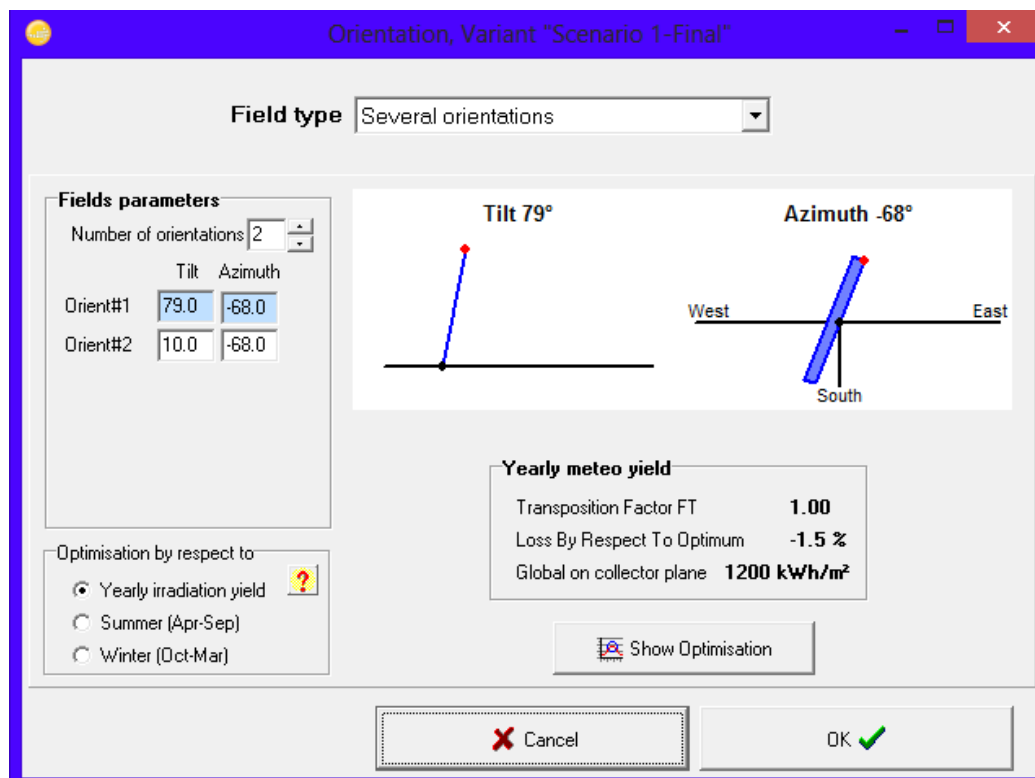
**Fig 3.13 Orientation of Façade Surface**

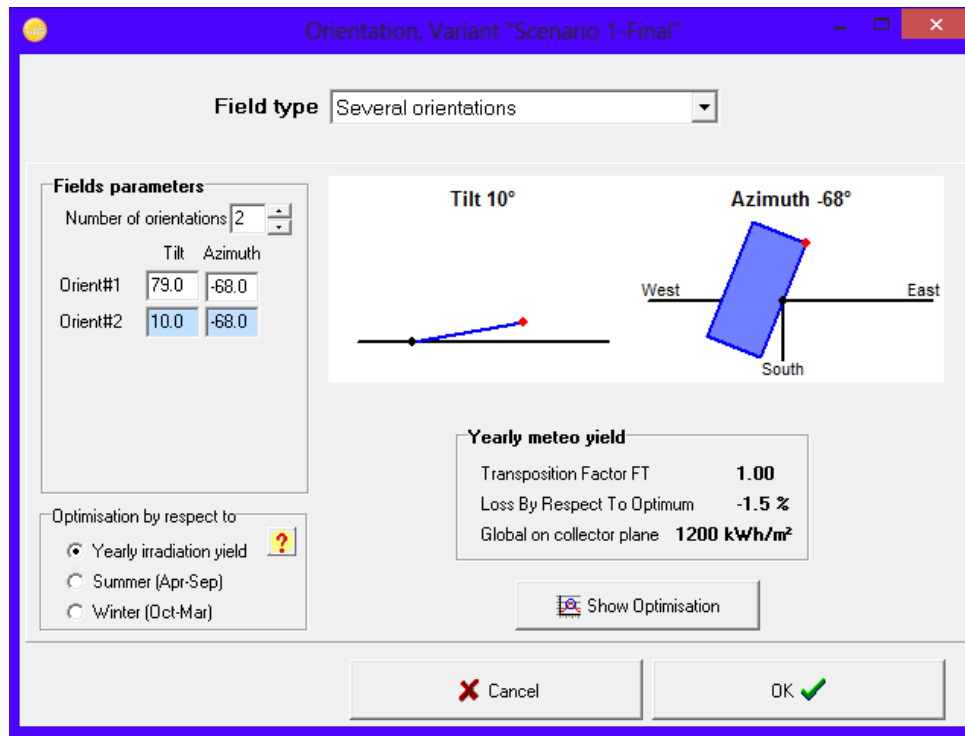

Fig. 3.14 Orientation of Rooftop and Podium

For the second scenario the tilt angle of the façade surface was modified to 60°.The orientation of the façade surface modified for the second scenario is as shown in Figure 3.15.

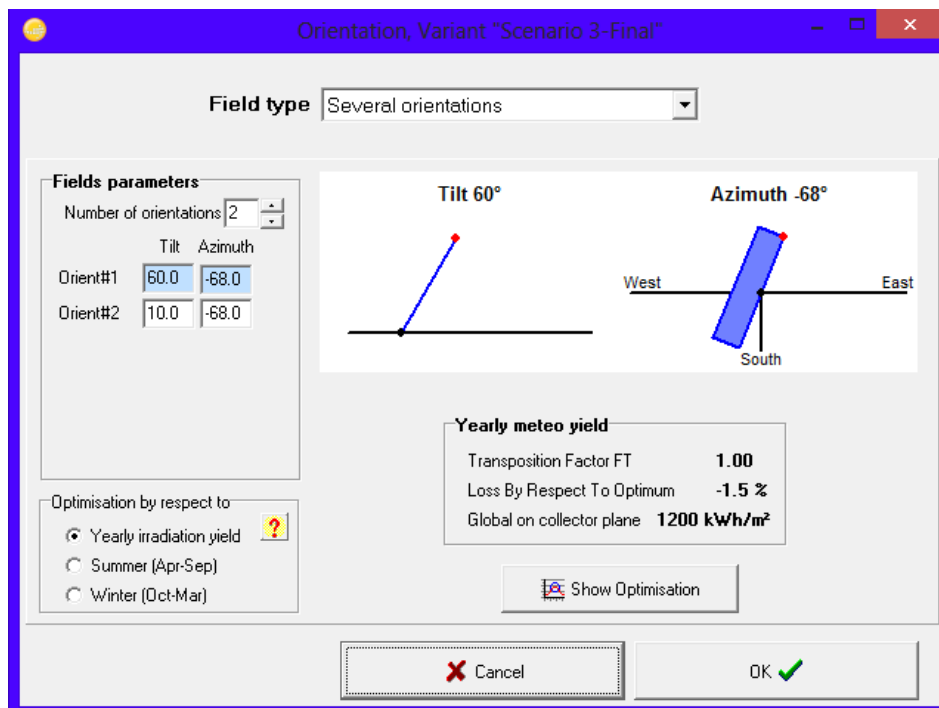

Fig. 3.15 Modified Orientation of Facade Surface for the Second Scenario

The third and fourth scenarios were simulated considering the optimum tilt angle which is 10° (almost equivalent to the latitude of the site under consideration) as displayed in Figure 3.16.

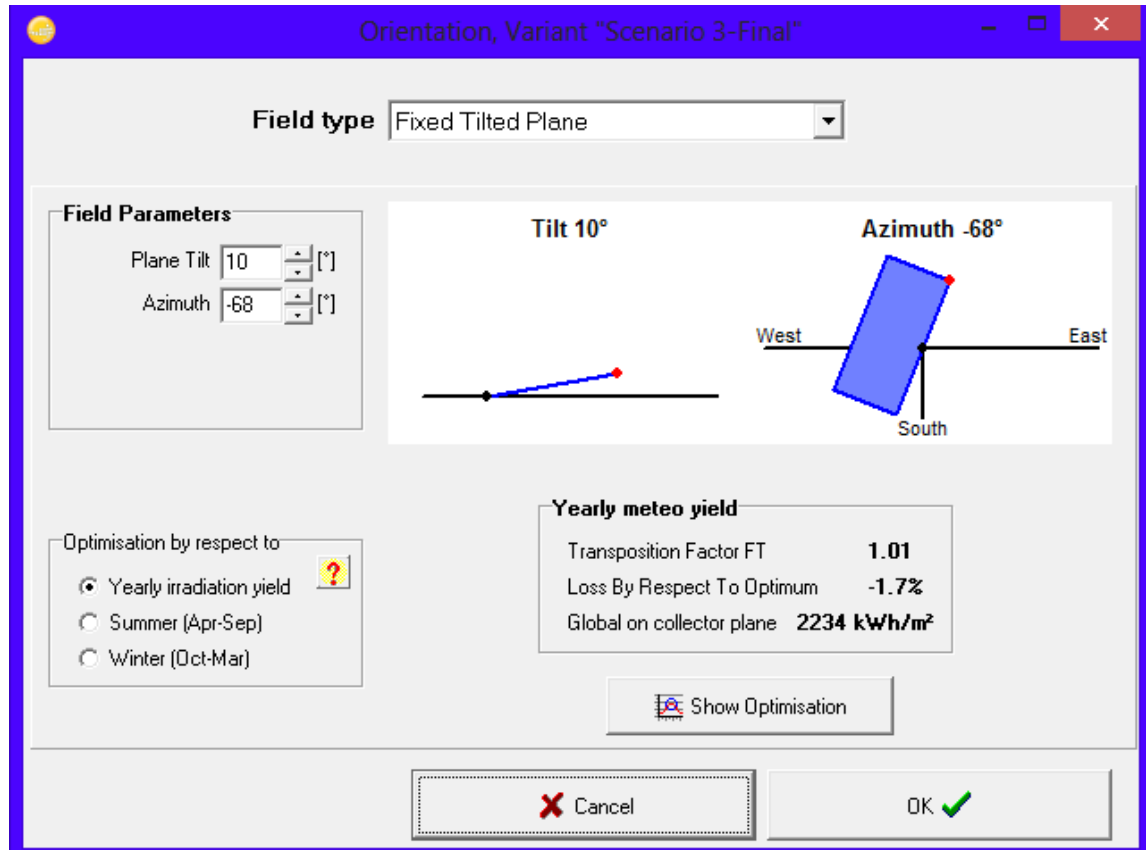

Figure 3.16 Modified Orientation of Facade Surface for the Third and Fourth Scenarios

3.3.2.2 System Definition

The system definition includes the details of the PV array and the inverter to be used. By defining the under listed requirements, PVsyst will automatically propose a suited arrangement.

- The desired nominal power or the available area for installing modules
- The inverter model
- The photovoltaic module model

Accordingly, the available roof, podium and facade areas suitable for PV integration for each scenario are summarized as shown in Table 3.8.

Table 3.8 Available Area for PV Integration

Part of the Building	Available Area for PV Integration (m ²)			
	First Scenario	Second Scenario	Third Scenario	Fourth Scenario
Façade	1178 ⁵	2356 ⁶	3934 ⁷	-
Rooftop	188 ⁸	188		188
Podium	1390	1390		1390

The modules were selected from the list of products already available in the software's database. For the rooftop and podium of all the four scenarios, a module named MegaSlate II manufactured by 3S Swiss Solar Systems was used. It is a mono-crystalline BIPV module specifically designed for roofing systems [24]. For the façade system of the first scenario, thin-film solar module manufactured by Schott Solar AG was selected. This type of module was selected mainly due to the curved architectural shape of the building and since flexible PV modules can only be manufactured from thin film PV cells. For the façade of the second scenario, a mono-crystalline façade module manufactured by 3S Swiss Solar Systems was selected since the façade was assumed to have a constant tilt angle of 60° rather than a curved shape with variable tilt angle. The specifications of the modules used for each scenario are summarized in Table 3.9.

⁵ It can easily be observed from Figure 3.2 that only part of the façade above the fifteenth floor has a good solar access due to the curved shape of the building.

⁶ Since a constant tilt angle of 60° is used all the façade area of the thirty floors can be used for PV integration.

⁷ All the available area is assumed to be tilted at 10°.

⁸ The total rooftop area is 268.71m². The suitable area for PV integration is reduced by 30% for access road.

Table 3.9 Specifications of PV Modules Used for Each Scenario

Properties	All Scenarios- Rooftop & Podium	1 st Scenario-Façade	2 nd Scenario- Façade
Manufacturer	3S Swiss Solar Systems	Schott Solar AG	3S Swiss Solar Systems
Dimensions	1200x875x6.5 mm ³	1308x1108x35 mm ³	1331x1319x42 mm ³
Weight	17 kg	20.8 kg	40 kg
Module Area	1.137 m ²	1.449 m ²	1.756 m ²
Cell Type	Mono-crystalline Silicon	a-Si-H (Hydrogenated Amorphous Silicon) Tandem	Mono-crystalline Silicon
Cell Connection	40 cells in series	24 cells in series and 3 cells in parallel	64 cells in series
Total Number of Cells	40	72	64
Module Area	1.137 m ²	1.449 m ²	1.756 m ²
Short Circuit Current (I_{sc})	8.57 A	4.2 A	8 A
I_{mpp} (Current at Maximum Power Point)	8.09 A	3.64 A	7.4 A
V_{oc} (Open Circuit Voltage)	24.64 V	41.70 V	39.10 V
V_{mpp} (Voltage at Maximum Power Point)	19.79 V	30.70 V	32.10 V
Temperature Coefficient	1.7mA/°C	3.4 mA/°C	3.7 mA/°C
Nominal Power at STC	160 Wp	112 Wp	237 Wp

The behavior of MegaSlate II module for different irradiance levels is displayed in Figures 3.16 and 3.17 below.

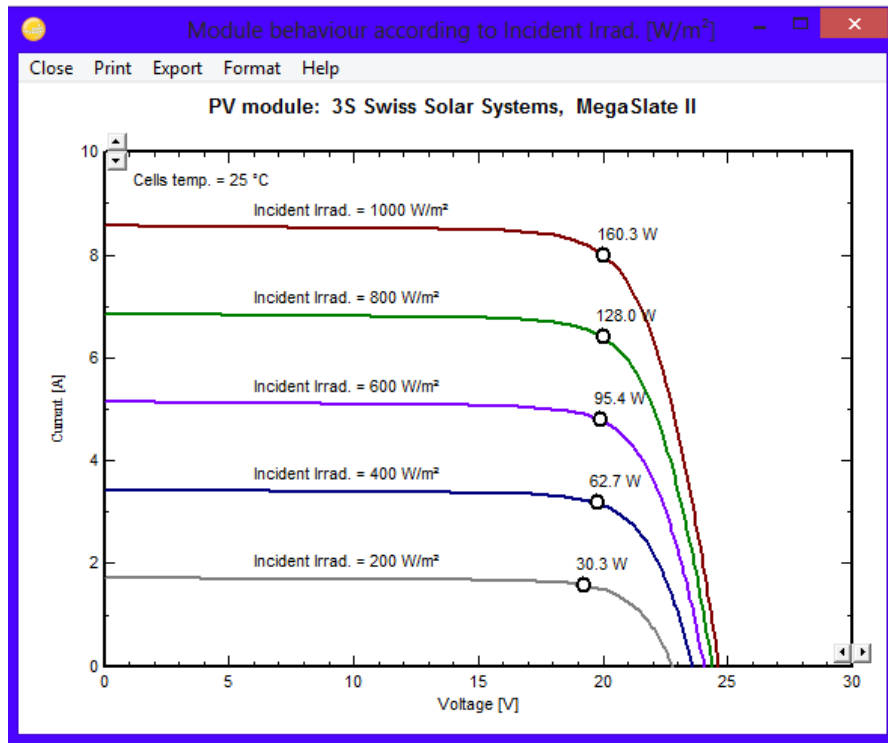

Fig. 3.16 I-V Curve of the MegaSlate II Module for Different Irradiance Levels

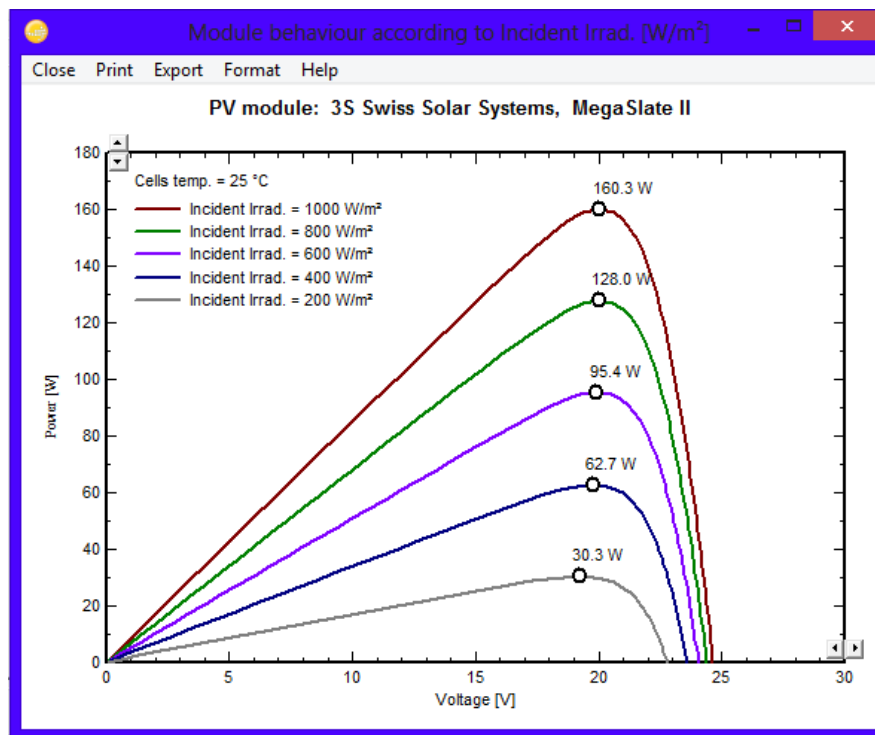

Fig. 3.17 Power Curve of MegaSlate II Module for Different Irradiance Levels

The behavior for different irradiance levels of Schott Solar AG, PROTECT ASI CLIME112 Module is displayed in Figures 3.18 and 3.19 below.

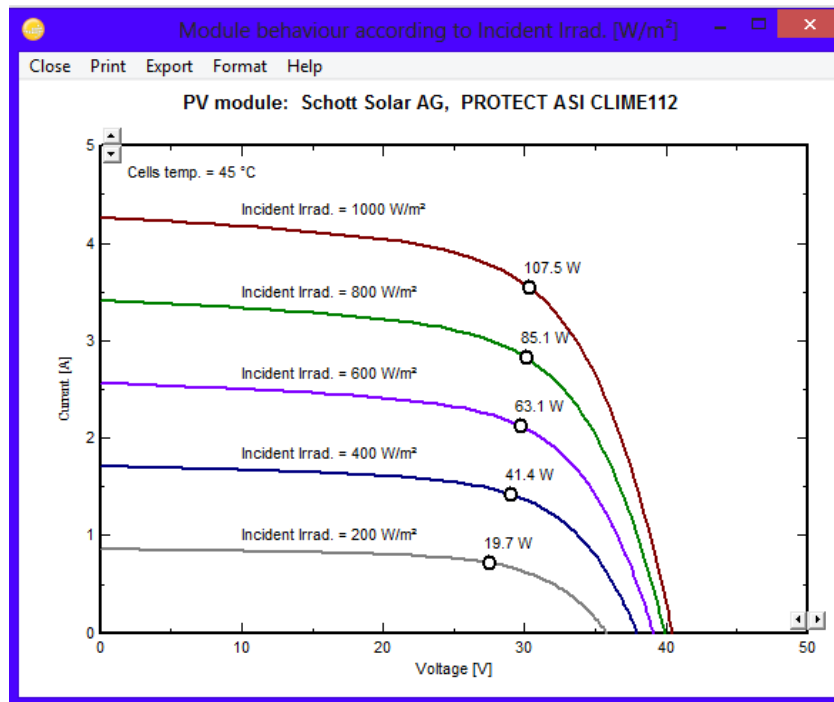

Fig. 3.18 I-V Curve of the Schott Solar AG, PROTECT ASI CLIME112 Module for Different Irradiance Levels

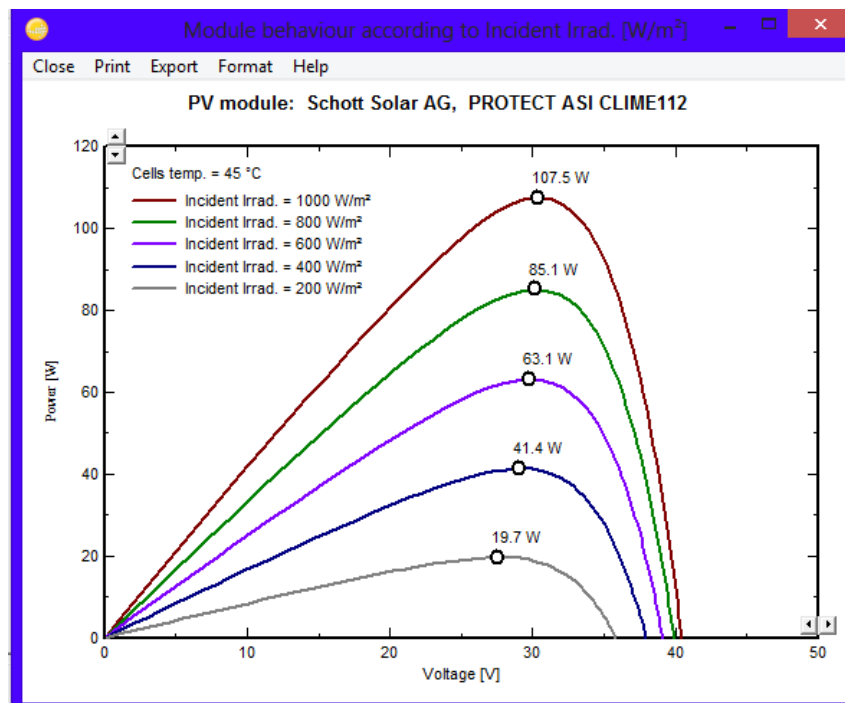

Fig. 3.19 Power Curve of the Schott Solar AG, PROTECT ASI CLIME112 Module for Different Irradiance Levels

The corresponding module behavior of 3S Swiss Solar Systems Facade Module for different irradiance levels is displayed in Figures 3.20 and 3.21 below.

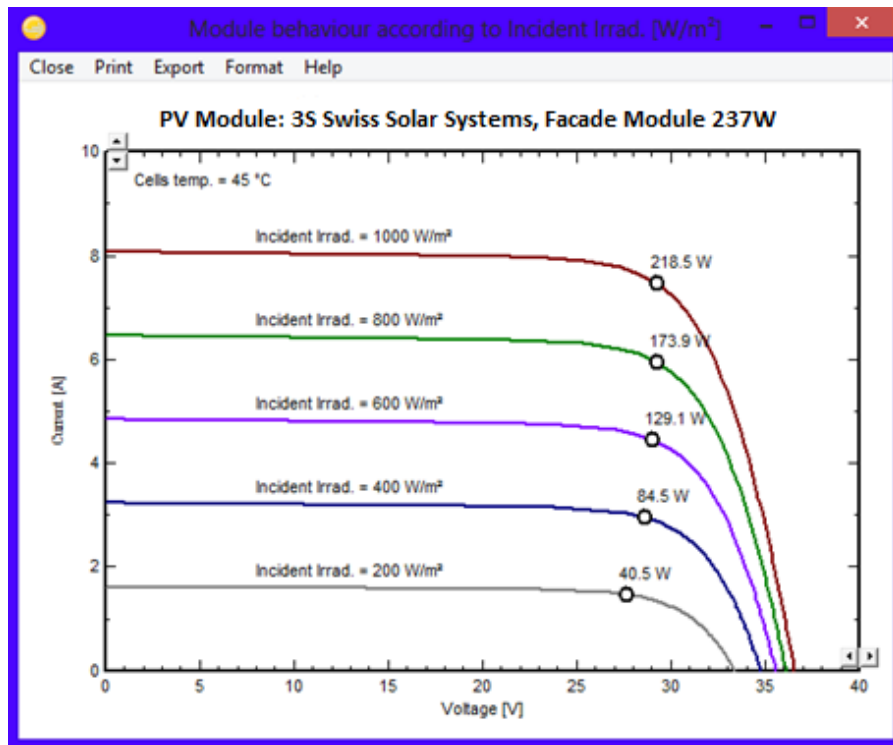

Fig. 3.20 I-V Curve of 3S Swiss Solar Systems Facade Module for Different Irradiance Levels

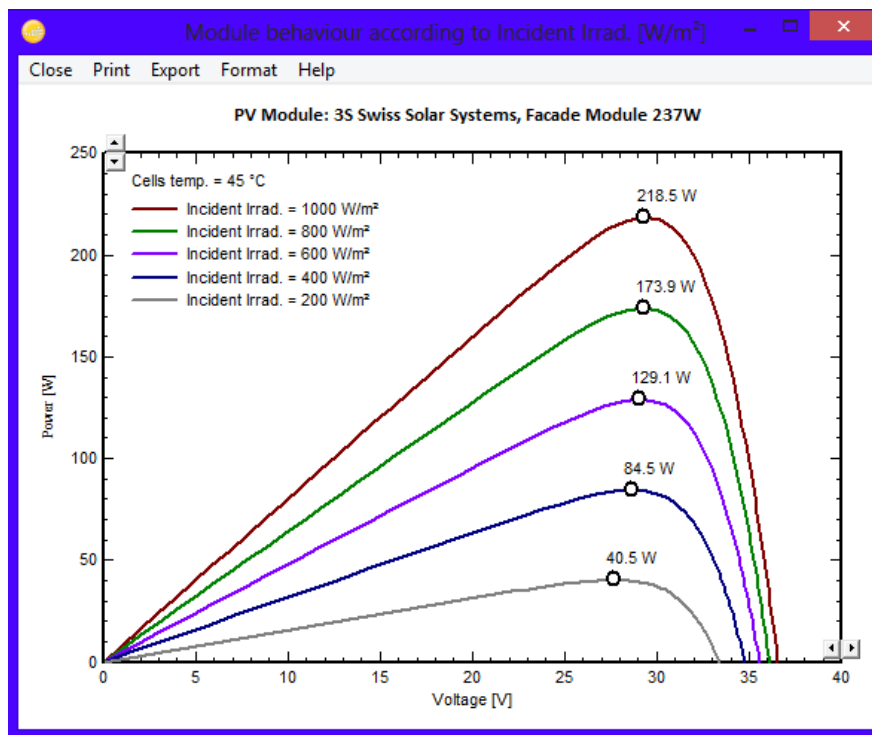

Fig. 3.21 Power Curve of 3S Swiss Solar Systems Facade Module for Different Irradiance Levels

On the other hand, grid-tie solar inverters with the specifications shown in Table 3.10 were selected from the PVsyst database for the four scenarios.

Table 3.10 Inverter Specifications Selected for Each Scenario

Properties	Values					
	1 st Scenario		2 nd Scenario		3 rd Scenario	4 th Scenario
	Rooftop & Podium	Façade	Rooftop & Podium	Façade	Rooftop, Podium & Façade	Rooftop & Façade
Manufacturer	Dasstech	Hyundai	Dasstech	Dasstech	Dasstech	Dasstech
Dimensions	1650x1000x850 mm ³	1794x700x700 mm ³	1650x1000x850 mm ³	1650x1000x850 mm ³	1650x1000x850 mm ³	1650x1000x850 mm ³
Weight	400 kg	530 kg	400 kg	420 kg	420 kg	400 kg
Minimum MPP Voltage	200 V	300 V	200 V	200 V	200 V	200 V
Maximum MPP Voltage	820V	600 V	820 V	820 V	820 V	820 V
Grid Voltage	380 V	380 V	380 V	380 V	380 V	380 V
Nominal AC Power	75 kW	30 kW	75 kW	100 kW	100 kW	75 kW
Type	Three Phase, Transformerless	Three Phase, with Transformer	Three Phase, Transformerless	Three Phase, Transformerless	Three Phase, Transformerless	Three Phase, Transformerless
Frequency	50/60 Hz	50/60 Hz	50/60 Hz	50/60 Hz	50/60 Hz	50/60 Hz
Efficiency	96.6%	95.6%	96.6%	96.5%	96.5%	96.6%

All the above explained parameters are defined in the dialog box shown in Figure 3.22.

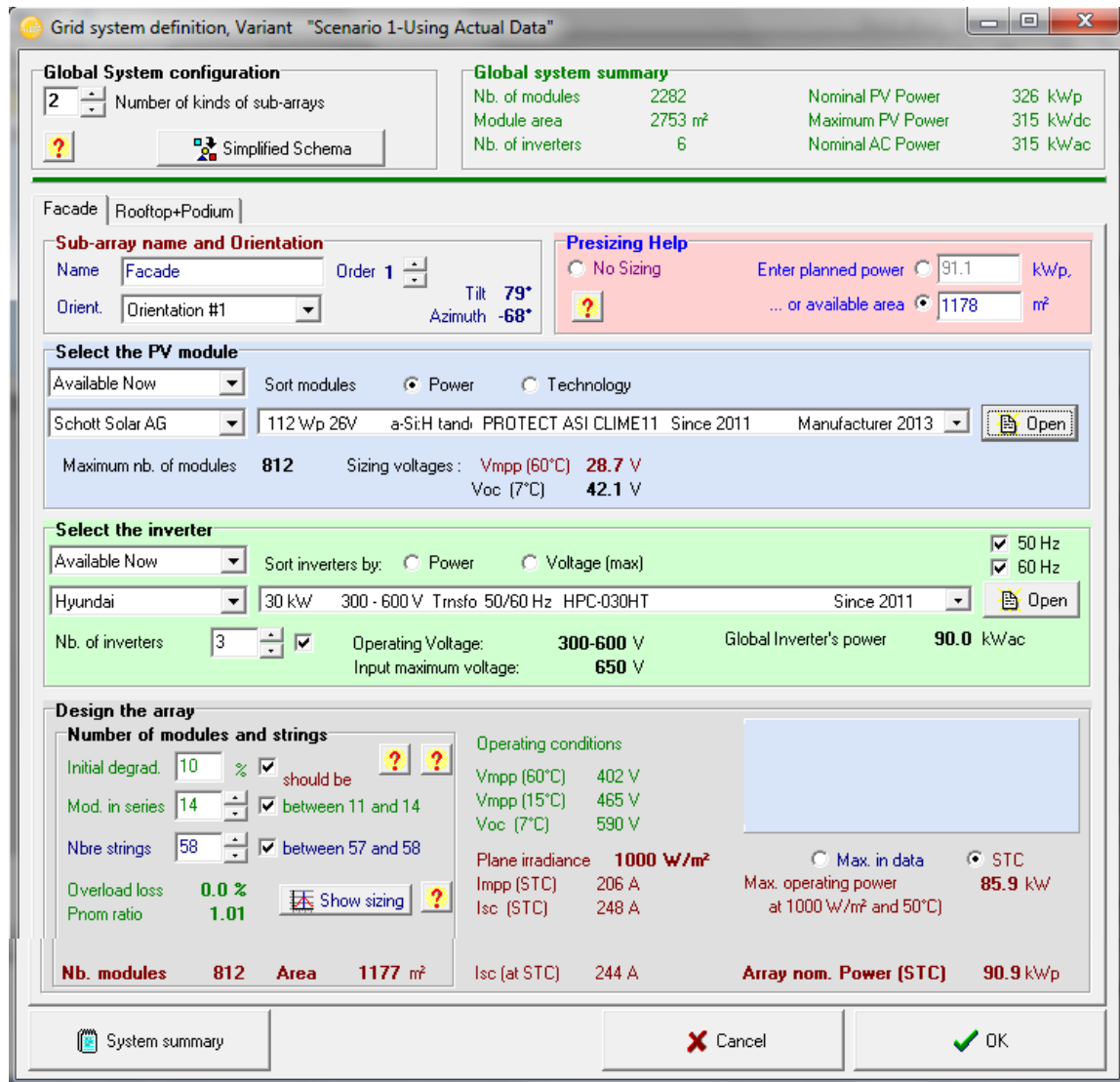

Fig 3.22 System Definition Dialog Box

3.3.2.3 Detailed Losses

For the detailed losses, the values shown in Table 3.11 were taken as input for all scenarios.

Table 3.11 Input Values for Detailed Losses

No.	Loss Type		Value	
1	Thermal loss			
1.1	Constant loss factor		15 W/m ² ·k	
1.2	Wind loss factor		0	
2	Ohmic loss		1.5% (Loss fraction at STC)	
3	Module quality loss		For a-Si module-0.8% For mono-crystalline Si-1.5%	
4	LID (Light Induced Degradation) Loss		For a-Si PV-0 For mono-crystalline Si-2%	
5	Array Mismatch Loss			
5.1	Power loss at MPP		1%	
5.2	Loss when running at fixed voltage		0%	
6	Soiling loss			
	January	July	2	0.5
	February	August	2	0.5
	March	September	1.5	1.5
	April	October	1.5	2.0
	May	November	2	2.0
	June	December	1	2.0
7	Array Incidence Loss (IAM)		b ₀ = 0.05	
8	Unavailability Loss		2%	

3.4 Economic Evaluation

PVsyst software offers a tool used for economic evaluation of the system on the basis of the defined parameters and the simulation results. The procedure for the economic evaluation of all the four scenarios is described below.

The first step was calculation of the investment. The number and type of system components (PV modules, inverters, etc.) were automatically updated from the simulation

parameters. Prices were then defined for each component. Costs can be defined globally, per pieces, installed W_p or area (m^2). For this study, price per W_p was used.

The prices used for the economic evaluation of the BIPV system were estimated using the estimated costs for different types of PV systems in South Africa. Accordingly, the total installation cost for commercial/industrial scale PV system is R20.00/ W_p . PV modules make up approximately 50% of the cost of grid connected PV systems. The other cost is attributable to the balance of system components, labor cost, etc.

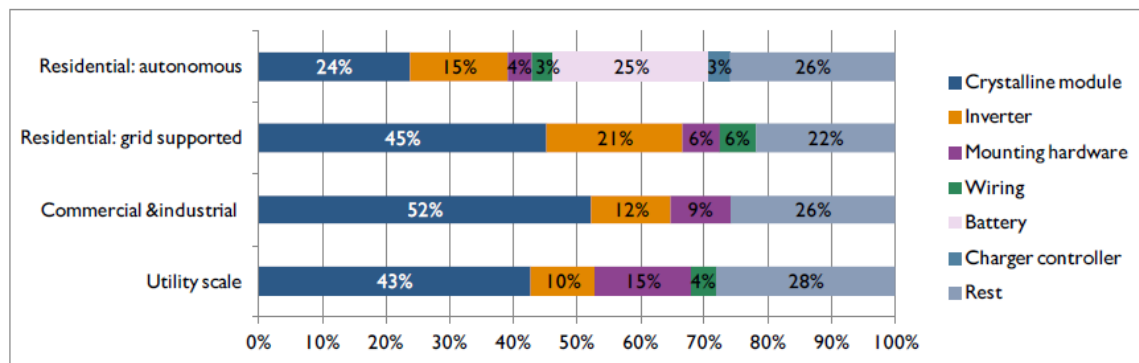

Fig. 3.23 Percentage Cost Breakdown of PV Systems (Source: EScience et al, 2013)

After defining the component prices, PVsyst calculated the gross investment excluding taxes. The net investment, for the owner is the gross investment plus a tax percentage (VAT). However, for this study, the VAT was assumed to be zero.

Following that, values for loan duration and interest rate were chosen and the software computed the annual financial cost, assuming the loan pay back as constant annuities. PVsyst takes the loan duration to be the expected lifetime of the system. This procedure is justified by the fact that, when purchasing a solar equipment the customer buys at a time the value of the whole energy consumed during the exploitation. The expected lifetime of the system was taken as 25 years and the interest rate as 0.5%.

The next step was determination of the running costs. For grid-connected systems, such costs are limited to annual inspection and cleaning of the collectors and insurance fees. The total annual cost was then determined as the sum of the annuities and running costs. This total annual cost divided by the effectively produced and used energy gave the energy cost (price per used kWh). Table 3.12 summarizes the input data used for the economic evaluation of the BIPV system.

Table 3.12 Input Data Used for Economic Evaluation

Investment		
No.	Component	Cost (US\$/W_p)
1	PV Module	0.89
2	Inverter	0.27
3	Integration	0.16
4	The rest of the investment cost (Supply chain cost, labor cost, installer profit, sales tax, etc)	0.46
Gross Investment		1.78
Financing		
1	Taxes	0
2	Subsidies	0
Net Investment		1.78
Annuities		0.08
Running and Maintenance cost		0.1
Total Yearly Cost		0.18

The software's dialog box used for entering the data displayed in Table 3.12 is shown in Figure 3.24.

Economic evaluation

Project and Simulation variant
 Project: Grid-Connected BIPV Project at Addis Ababa (Zemen Bank HQ Building)
 Simulation: Revision scenario 1 Variant
 PV Array, Pnom = 326 kWp System: Grid-Connected System
 System with 2 different sub-fields defined

Values:
 Global By Wp
 By piece By m²

Investment

PV modules	2282 units	0.89	US\$ / Wp
Supports / Integration		0.16	US\$ / Wp
Inverters	6 units	0.27	US\$ / Wp
Settings, wiring, ...		0.46	US\$ / Wp
Others, miscellaneous...	<input type="button" value="Details"/>	0.00	US\$ / Wp
Substitution underworth		0.00	US\$ / Wp
Gross investment, (excl. taxes)		1.78	US\$ / Wp

Sub-field's components

Sub-field:

PV module: MegaSlate II
 1470 units 0.00 US\$ / Wp

Inverter: Soleaf DSP-3375K
 3 units 0.00 US\$ / Wp

Loan
 Duration: 25 Years
 Rate: 0.5 %
 Ann. factor 4.27 %cap./yr

Currency
 United State

Energy cost

Produced Energy	456	MWh / year
Yearly cost	57361	US\$ / year
Energy cost	0.13	US\$ / kWh

Financing

Taxes	0.00 %	0.00	US\$ / Wp
Subsidies	- 0.00	0.00	US\$ / Wp
Net investment		1.78	US\$ / Wp
Annuities		0.08	US\$ / Wp
Running Costs, Maintenance, insur.		0.10	US\$ / Wp
Total yearly cost		0.18	US\$ / Wp

Fig 3.24 PVsyst Dialog Box used for Input Data of Economic Evaluation

PVsyst also provides a means of estimating the long term profitability of grid-connected systems according to different feed-in tariff conditions. For grid-connected systems, the produced electricity may be either consumed by the owner or sold to the grid utility. In both cases, the produced electricity has a financial value to be compared to the annual costs in order to evaluate the system profitability. This part performs an annual balance between costs and revenues according to several possible feed-in tariffs. Feed-in tariffs are policy mechanisms designed to accelerate investment in renewable energy technologies by providing investors with a fee (tariff) above the retail rate of electricity. However, there are no such tariffs in Ethiopia currently and hence such analysis is not done for this study.

Chapter 4

Results and Discussion

4.1 Energy Production

As stated in chapter three, four different types of scenarios were considered in this study. The first scenario was simulated using an average tilt angle of 79° for the façade and 10° for the rooftop and the upper surface of the podium which is based on the actual data obtained from the Architectural Design Office of Zemen Bank Headquarter Building. The second was considering a modified average tilt angle of 60° for the façade keeping the other conditions the same. The third scenario was simulated by assuming all the available areas (the rooftop, podium and façade) to be tilted at the optimum angle of 10° to find the maximum energy yield and the result was used as a reference. The last scenario was simulated by using only the rooftop and the podium surfaces having a tilt angle of 10°. For the first two scenarios, two types of array fields (zones) were defined, one for the rooftop and the podium and the other for the façade of the BIPV system of the building. For the last two scenarios, a single array field (zone) was used since all the PV modules were assumed to be tilted at an angle of 10°. The results of PV array sizing and major outputs for each scenario are summarized in Table 4.1 below.

Table 4.1 Results of Array Sizing for Each Scenario

Description	1 st Scenario		2 nd Scenario		3 rd Scenario	4 th Scenario
	Rooftop & Podium	Façade	Rooftop & Podium	Façade	Rooftop	Rooftop & Podium
<i>No. of Modules in Series</i>	21	14	21	13	28	21
<i>No. of Strings</i>	70	58	70	103	131	70
<i>Total No. of Modules</i>	1470	812	1470	1339	3668	1470
<i>Module Area</i>	1578	1177	1578	2356	3934	1578
<i>No. of Inverters</i>	3	3	3	6	5	3

	1 st Scenario	2 nd Scenario	3 rd Scenario	4 th Scenario
<i>System Production</i> [MWh/year]	456	749	897	359
<i>Specific Production</i> [kWh/kW _p /year]	1399	1355	1528	1527
<i>Performance Ratio</i>	0.791	0.778	0.782	0.781
<i>Normalized Production</i> [kWh/kW _p /day]	3.83	3.71	4.19	4.18
<i>Array Losses</i> [kWh/kW _p /day]	0.74	0.8	0.9	0.9
<i>System Losses</i> [kWh/kW _p /day]	0.28	0.26	0.27	0.27

As can be observed from Table 4.1, the system production of the first scenario using an average tilt angle of 79° and half of the façade area plus the rooftop and podium areas is very low as compared with that of the second scenario. For the second scenario, a constant tilt angle of 60° was assumed for the whole facade. Hence, it was possible to use all the façade area for PV integration instead of starting from the 15th floor. Moreover, assuming a constant tilt angle made possible the use of crystalline silicon based PV modules instead of thin-film PV modules since the shape of the façade is not curved and flexibility is not an issue. All these factors have contributed for the significant increment in system production.

The percentage difference of the three scenarios from the optimum is displayed in Table 4.2 below.

Table 4.2 Percentage Difference of Each Scenario from the Optimum

Description	Array Field Area	Energy Yield	Percentage Difference from the Optimum
Scenario 1	2754	456	49.16%
Scenario 2	3934	749	16.5%
Scenario 3	3934	897	0
Scenario 4	1577	359	59.97%

As can be observed from Table 4.2, the percentage difference of the energy output of the first scenario is 49.16%. However, the second scenario (tilt angles of 10° and 60° for rooftop & podium and façade, respectively) is only less than the optimum by 16.5%. Hence, this shows that a significant amount of energy can be generated from the façade with a tilt angle of 60° . On the other hand, the fourth scenario demonstrates that considerable amount of energy can be generated from small PV array field area at optimum orientation of PV arrays.

Performance Ratio (PR) is a quality factor calculated as the ratio of actual energy produced and the energy which would be produced by a system continuously operating at Standard Test Conditions (STC). It is used to measure the quality of the product independent of irradiance. Depending on various factors, PR values may range from 0.2 to 0.8. As can be seen from Table 4.1, all the PR values for all the scenarios is approximately 0.8.

Specific energy production or the final yield is another performance indicator of a PV system which is expressed in kWh/kWp/year. It is the ratio of the produced energy and the nominal power of the array (P_{nom} at STC). Figures 4.1 to 4.4 show the daily final yield per each month of the year for every scenario.

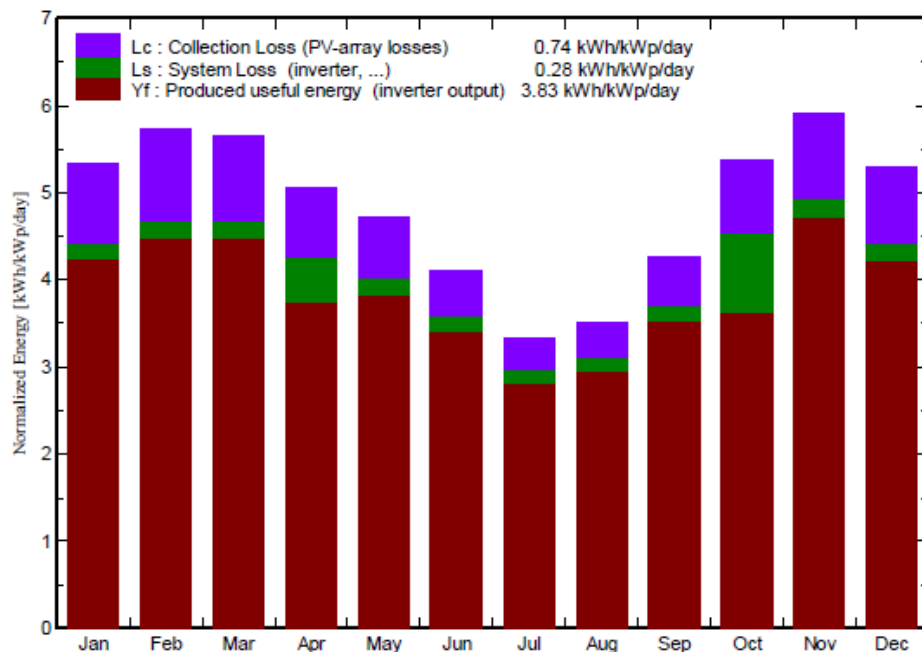

Fig 4.1 Normalized Productions (per installed kW_p): Nominal Power 326kW_p (First Scenario)

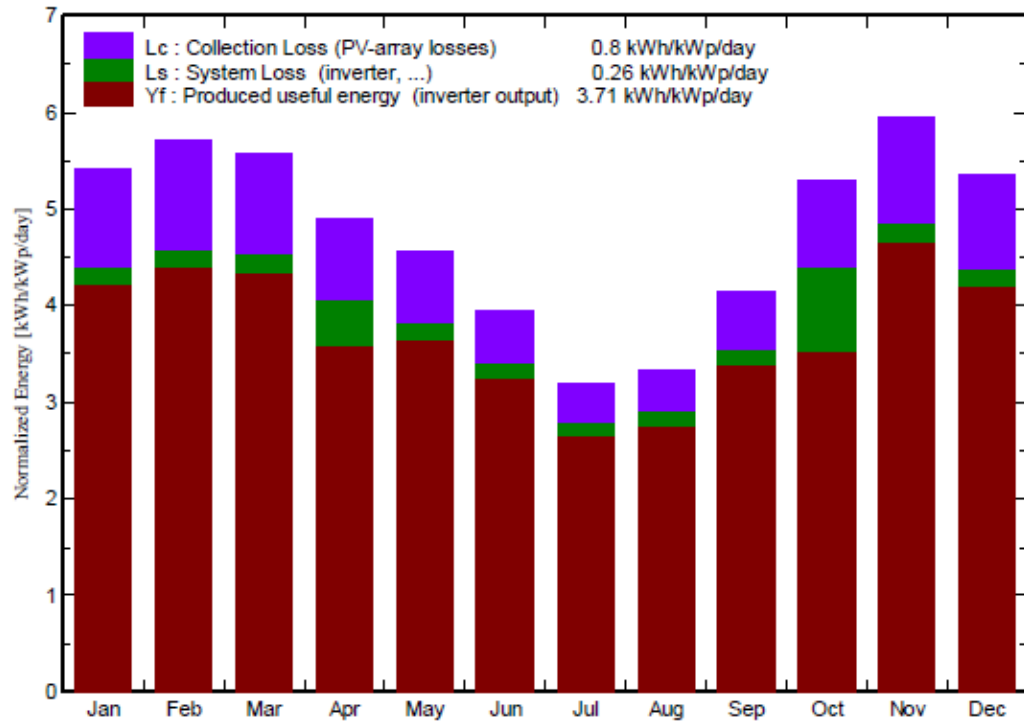

Fig 4.2 Normalized Productions (per installed kW_p): Nominal Power 553kW_p (Second Scenario)

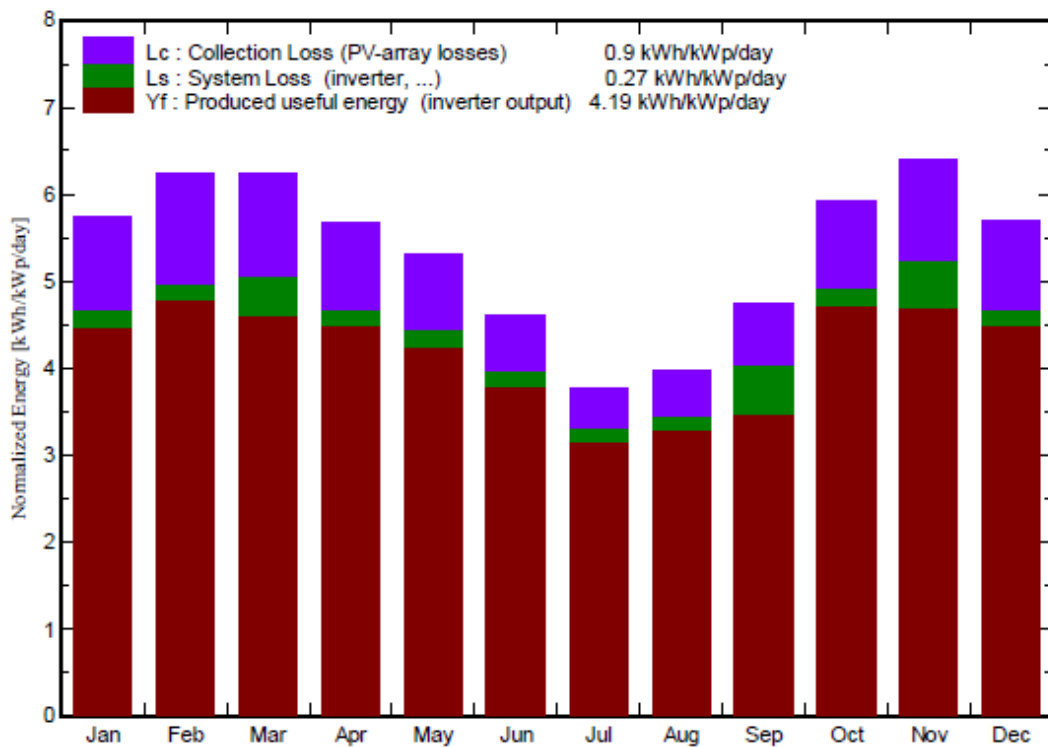

Fig 4.3 Normalized Productions (per installed kW_p): Nominal Power 587kW_p (Third Scenario)

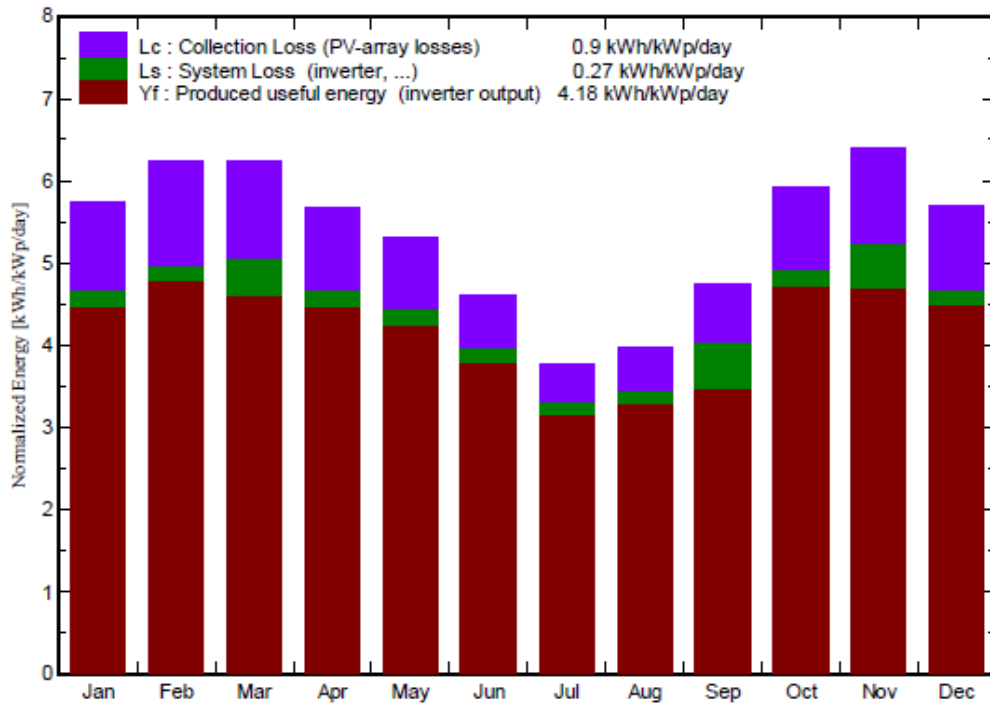

Fig 4.4 Normalized Productions (per installed kW_p): Nominal Power 235kW_p (Fourth Scenario)

The loss diagrams showing all the losses that reduce the energy yield are shown in Figures 4.5 and 4.8.

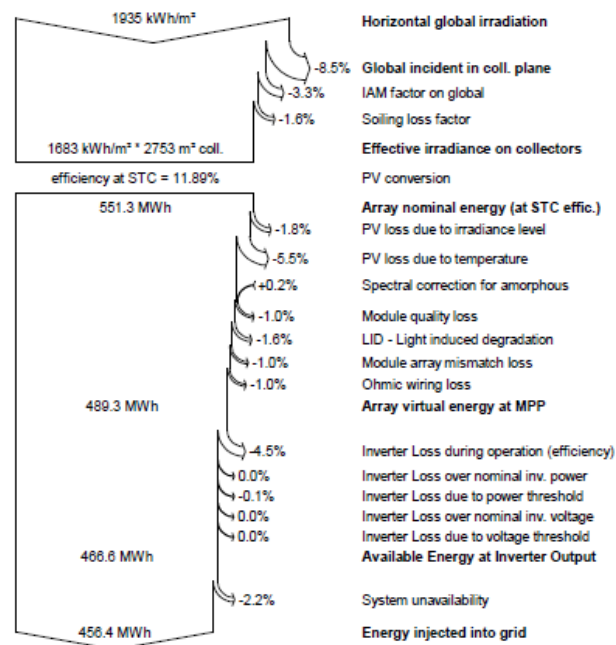

Fig.4.5 Loss Diagram of the BIPV System (First Scenario)

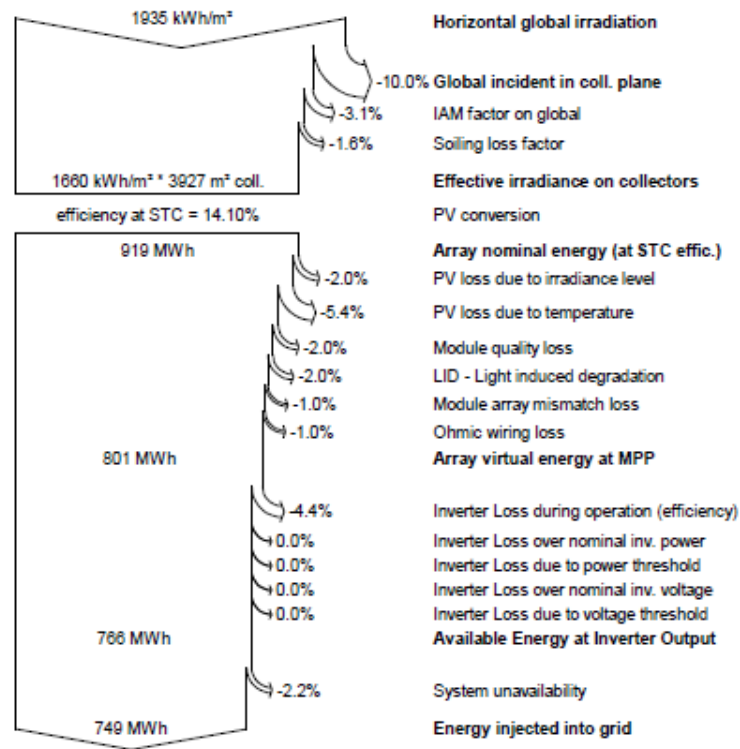

Fig. 4.6 Loss Diagram of the BIPV System (Second Scenario)

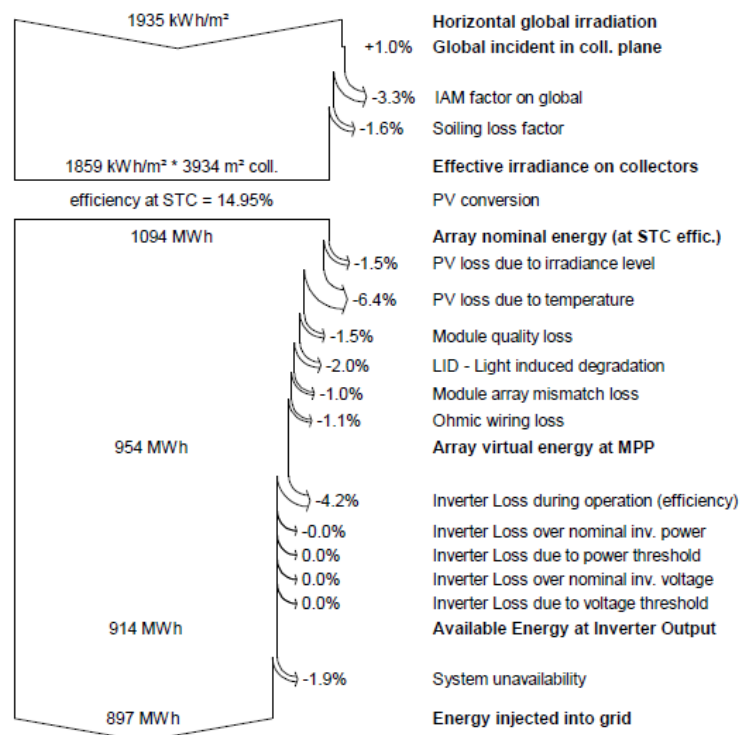

Fig.4.7 Loss Diagram of the BIPV System (Third Scenario)

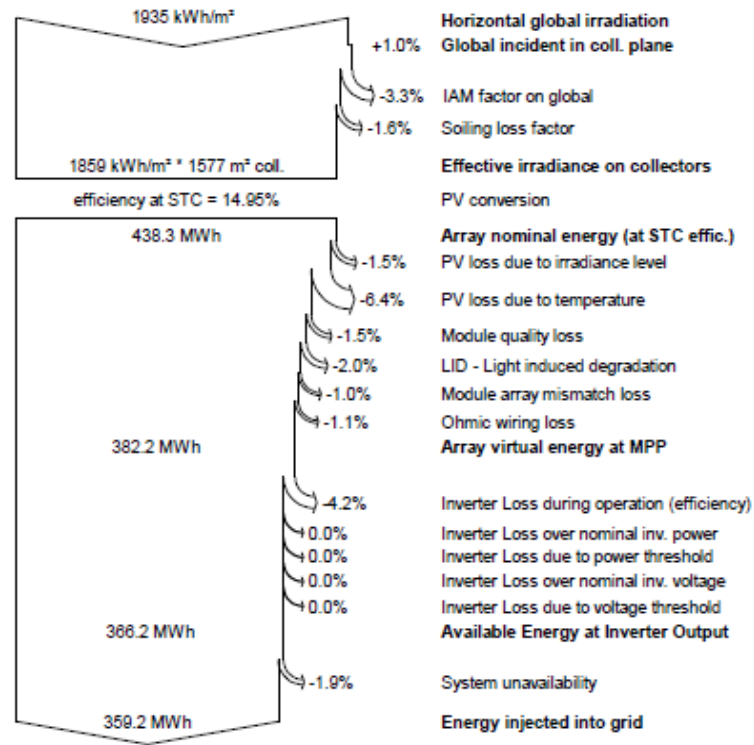

Fig.4.8 Loss Diagram of the BIPV System (Fourth Scenario)

4.2 Results of Economic Evaluation

The results of economic evaluation for the four scenarios are displayed in Table 4.3. It can be observed that the last two scenarios have lowest energy cost as compared with the others.

Table 4.3 Results of Economic Evaluation of Each Scenario

Description	First Scenario	Second Scenario	Third Scenario	Fourth Scenario
Investment(US \$)	580,210	981,979	1,042,886	417,950
Specific Investment (US \$/W _p)	1.78	1.78	1.78	1.78
Energy Cost (US \$/kWh)	0.13	0.13	0.11	0.12

The amount of energy that can be saved from the BIPV system of each scenario and the corresponding financial saving are displayed in Table 4.4.

Table 4.4 Energy and Financial Saving of Each Scenario

Scenario	Energy Yield [kWh/year]	Energy Demand of the Building [kWh/year]	Percentage of Energy Covered by BIPV System [%]	Amount Saved [USD per year]
First	456,000	1,289,977.49	35.35	13,680.00
Second	749,000		58.06	22,470.00
Third	897,000		69.54	26,910.00
Fourth	359,000		27.83	10,770.00

Chapter 5

Conclusion and Recommendation

5.1 Conclusion

As a country striving to become a middle income country in the coming ten years, Ethiopia's electricity demand and consumption is believed to increase significantly. More industries, commercial buildings and residential apartments shall be constructed in the near future which demand high electric power. The current strategy to achieve this increasing demand is more focused on the construction of hydro-electric power plants which are dependent on the uniformity of rainfall pattern.

On the other hand, Ethiopia is a country rich not only with large rivers but with high level of solar radiation almost throughout the year. Therefore, a comprehensive study was made to reveal the opportunities of meeting the electricity demand of residential or commercial buildings in Ethiopia using BIPV technologies taking Zemen Bank Headquarter Building as a case study.

Preliminary design of the BIPV system was done in order to identify parts of the building with good solar access, orientation and tilt angle and to select appropriate solar technologies. Following that, detailed technical design and modeling of the grid-tied BIPV system was performed. The simulation of the modeled system was performed considering four different scenarios in order to get an optimum energy output. The first scenario was using an average tilt angle of 79° for the façade and 10° tilt for the rooftop and podium based on the actual data obtained from the Architectural Design Office of Zemen Bank Headquarter Building. Simulating this scenario gave an annual energy yield of 456 MWh/year.

In the second scenario, a fixed tilt angle of 60° was assumed for the façade instead of having a curved shape with varying tilt angle at each point while that of the rooftop and the podium was still kept to be 10° . This has significantly improved the energy yield to 749 MWh/year.

For the third scenario, an optimum tilt angle of 10° which is equivalent to the latitude of the site was considered for all the available PV area including façade, rooftop and podium. The simulation gave an annual energy yield of 897 MWh/year. Such a tilt angle is possible only for a rooftop application or ground installation. However, in most cases, buildings with large compound and rooftop areas are not built. Instead, large surface areas are available on the facades of high rise buildings. Hence, this scenario was simulated only to be used as a reference for comparison with the rest of the scenarios.

The fourth scenario considered only the rooftop and the podium which are already designed to be at the optimum tilt angle of 10° based on the actual data. This gave 359 MWh/year energy yield annually. This shows that a significant amount of energy can be generated even from a small array field area if the PV arrays are at the optimum orientation.

The comparison of the energy yield from the first scenario (456 MWh/year) with the optimum (third scenario-897MWh/year) resulted in a percentage difference of 49.16% which is a significant amount. However, the energy yield from the second scenario (tilt angles of 10° and 60° for rooftop & podium and façade, respectively) was less than the optimum only by 16.5% showing that a considerable amount of energy can be generated with a tilt angle of 60° which is much higher than the latitude of the site.

Finally, the amount of energy that can be saved from the BIPV system of each scenario and the corresponding financial savings were analyzed. This revealed that, with an optimum design, a significant amount of energy and financial saving can be achieved.

From the above analysis, it can be deduced that rather than retrofitting an existing building, BIPV system should be considered starting from the initial architectural design of the building so that suitable orientations for PV integration can be achieved.

On the other hand, the economic evaluation showed that the energy cost of Photovoltaic technology is not competitive with the prevailing electricity retail price of Ethiopia. Currently the average tariff of electricity in Ethiopia is 0.03 USD/kWh which is much lower than the energy cost of the BIPV system for all scenarios as estimated by PVsyst

software. Grid-parity is not achieved because of generally lower generation and transmission costs for the grid. However, cost of power generation on the grid is rising while PV prices are dropping closing the cost gap. Hence, it can be concluded that PV technology will achieve grid-parity and become a feasible alternative green energy resource in the long run.

5.2 Recommendation

Based on the study made, the following recommendations are forwarded.

- Policies that support the grid connection of PV systems should be formulated.
- The government should subsidies such investments in the energy sector.
- Policies that support the use of feed-in-tariff should be formulated.
- A comparative advantage can be gained by manufacturing PV modules locally.
- Tax incentives should be provided to encourage the involvement of the private sector in PV technology investments.
- Further researches shall be made in order to fully understand the significance and strategic value of solar PV power generation in the overall planning of national energy economy.

Bibliography

1. **Federal Democratic Republic of Ethiopia, Environmental Protection Authority.** [Online] 2011.
2. [book auth.] Ministry of Water and Energy. *Scaling-Up Renewable Energy Program*. Addis Ababa : s.n., 2012.
3. Diversity and Security for the Ethiopian Power System. [book auth.] Ethio Resource Group (ERG) for Heinrich Boll Found. 2009.
4. *Photovoltaic Software*. [Online] 2012.
<http://www.pvresources.com/SiteAnalysis/Software.aspx>.
5. **Agency, Ethiopian News.** [Online]
http://213.55.98.22/enaef/index.php?option=com_k2&view=item&id=1685:ethiopia-approves-3-new-solar-projects&Itemid=205#.U_SQRvldUTo.
6. **Roberts, Nicolo Guariento and Simon.** *Building Integrated Photovoltaics/ A Handbook*. Basel, Boston, Berlin : German National Library, 2009.
7. **Breivik, Christer.** *Building Integrated Photovoltaics - A State of the Art Review* . 2012.
8. **J.Kiss, Patrina Eiffert and Gregory.** *Building Integrated Photovoltaic Designs for Commercial and Institutional Structures, A Source Book for Architects*. Newyork : s.n., 200.
9. **Erge, Friedrich Sick and Thomas.** *Photovoltaics in Buildings, A Design Handbook for Architects and Engineers*.
10. Solar inverter-Wikipedia, the free encyclopedia. [Online]
http://en.wikipedia.org/wiki/Solar_inverter.
11. *Micro, String and Central Solar Inverters-Energy Matters*. [Online]
<http://www.energymatters.com.au/renewable-energy/inverters/micro-string-central-inverters.php>.
12. *Building Integrated Photovoltaics (BIPV) Market By Products, Technologies & Applications (2011-2016)*. [Online] <http://www.marketsandmarkets.com/Market-Reports/bipv-market-509.html>.
13. **Group, Ethio Resource.** *Solar Energy Vision for Ethiopia*. Freiburg, Addis Ababa : s.n.
14. **Meoud, Andre.** PVsyst Help. Geneva : s.n., 2014.
15. **PHILIPS.** *PHILIPS Lamps & Lighting Electronics Catalogue* . 2013.
16. *Outdoor lighting-Efficiency and Cost Data*. [Online] 2014.
http://www.nofs.navy.mil/about_NOFS/staff/cbl/lumentab.html.
17. **NREL.** NREL:Sustainable NREL-Cafeteria. [Online] January 09, 2014.
http://www.nrel.gov/sustainable_nrel/buildings_cafe.html.
18. aps-solutions for buisness.com. [Online] <http://www.aps-solutionsforbusiness.com/ProjectCenter/Portals/54/OfficeEquipment.pdf>.

-
19. **(CMHC), Minto Energy Management in cooperation with city of Toronto and Canada Mortgage and Housing Corporation.** *Dmestic Cold Water Booster Pump Control Monitoring Pilot Program, 2001.* Totonto : s.n., 2001.
 20. *Connexed Technologies Inc.* [Online] www.connexed.com.
 21. *Kone.* [Online] 2014. <http://en.wikipedia.org/wiki/Kone>.
 22. *cdn.kone.com.* [Online] 2010.
http://cdn.kone.com/www.kone.co.uk/Images/KONE_MiniSpace.pdf?v=1.
 23. *PVsysT Tutorial.* [Online] January 2014. <http://www.scribd.com/doc/225368087/PVsysT-Tutorial>.
 24. *MegaSlate|Meyer Burger PV System.* [Online] 2013.
<http://pvsystems.meyerburger.com/en/products/in-roof/megaslate/>.
 25. **Alan Goodrich, Ted James and Michael Woodhouse.** *Residential, Commercial and Utility Scale Photovoltaic (PV) System in the United States: Current Drivers and Cost Reduction Opportunities.* s.l. : NREL, 2012.
 26. [book auth.] *Ethiopian Rural Energy Development and Promotion C. Solar and Wind Energy Utilization and Project Development Scenarios.s.l.* 2007.
 27. **Sushil Adhikanri, S.Kumar adn Pinij Sinpue Kpong.** *Technical Digest of the International PVSEC-14.* Bangkok : s.n., 2004.
 28. **Cristian P.Chioncel, Ladislau Augustinov, Petru Chioncel, Nicoleta Hillihc, Gelu OVIDIU Tirian.** *Performance Ratio of Photovoltaic Plant.* 2009.
 29. **Snow, Deo Parsad and Mark.** *Designing with Solar Power/ A Source Book for Building Integrated Photovoltaics(BIPV).* 2005.
 30. *Solectria Renewables.* [Online] <http://www.solren.com/>.
 31. **Nordahl, Siv Helene.** *Design of Roof PV Installation in Oslo.* 2012.
 32. **J.Kleinman, K.W Roth. F.Goldstein and.** *Energy Consumption by Commercial Office and Telecommunication Equipment.* 2004.

Appendix

Site plan, Sections and Front Elevations of Zemen Bank Headquarter Building