

**ADDIS ABABA UNIVERSITY
SCHOOL OF GRADUATE STUDIES**



**FACULTY OF TECHNOLOGY
DEPARTMENT OF CIVIL ENGINEERING**

**Analysis, Design and Cost Effectiveness of
Precast Beam-Slab System**

By
MATHEAS KEBEDE

Advisor: - Dr-Ing. GIRMA ZERAYOHANNES

A thesis submitted to the school of graduate studies of Addis Ababa University, in partial fulfillment of the requirements for the degree of Master of Science in Civil Engineering.

JULY 2009

ADDIS ABABA UNIVERSITY
SCHOOL OF GRADUATE STUDIES

Analysis Design and Cost Effectiveness of
Precast Beam-Slab System

BY: - MATHEAS KEBEDE

APPROVED BY BOARD OF EXAMINERS

Dr-Ing Girma Zerayohannes
(ADVISOR)

DATE

Dr. Isayas Gebreyohannes
(EXTERNAL EXIMINER)

DATE

Dr. Asnake Adamu
(INTERNAL EXIMINER)

DATE

Mr. Karsten Schlesier
(CHAIRPERSON)

ACKNOWLEDGMENT

“The almighty GOD shields me from the spears of my enemies, praise God”

First of all I would like to thank “Addis Ababa Administration Office of Works and Urban Development” for sponsoring my post graduate study.

This study was conducted under the supervision of my advisor Dr. Girma Z. Yohannes. I would like to express my deepest gratitude to Dr. Girma Z. Yohannes for his valuable Guidance.

I am also indebted to Ato Admassu Semeles’s thesis work which gave me some valuable ideas.

My heartfelt thanks are extended to Ato Daniel Kifle who assisted me in conducting the laboratory tests.

Finally I would like to thank my family and friends for their love and encouragement throughout the study period.

ABSTRACT

Pre-cast beam-slab is made of pre-cast reinforced concrete beam together with hollow blocks. The pre-cast beams are spaced at certain intervals and the hollow blocks are placed on them to form a working platform with out the use of formwork. The slab HCB, hanging between the pre cast beams are functioning like a formwork. They give only a temporary support during the installation phase. Only the pre-cast beams and the slab concrete are load bearing parts of the slab.

In our country pre-cast beam-slab system is not widely used for construction of most buildings. The conventional cast in situ constructions require lots of formwork and construction time, which increase the total cost of a project. When pre-cast beam slab systems are introduced in the construction of buildings, an economical construction could be achieved.

In the present study, two types of pre-cast beam elements are chosen. Experimental studies are made on these beam elements by casting them in the laboratory condition. From experimental observation, there tried to come up with a new theoretical model. Load-deflection data was taken from the experiment and compared with the theoretical output. Furthermore cost comparison is made between the two systems of slab construction. **For the arrangement of panels used to compare cost**, the pre-cast beam-slab system of construction is more economical than the conventional system. Finally, the model gives a hint for future study in trying to simulate the actual pre-cast beam slab system.

LIST OF TABLES**PAGE**

1.1.	Average Values of ' ΔM ' and ' C_s '	11
2.1.	Yield strength of main reinforcement bars	19
2.2.	Compressive strength test results of concrete cubes	22
2.3.	Slab- Design Template	27
2.4.	Slab- Design Template	28
2.5.	Gradation test results of fine aggregate	40
2.6.	Gradation test results of coarse aggregate	40
2.7.	Measured readings of load deflection test	41
2.8.	Experimental and Theoretical mid span deflection of PCB- Elements	42
3.1.	Cost calculation using solid slab system	37
3.2.	Cost calculation using pre-cast beam slab system	37
3.3.	Analysis sheet for total cost of concrete	54
3.4.	Analysis sheet for total cost of form work	55
3.5.	Analysis sheet for total cost of reinforcement	56
3.6.	Analysis sheet for total cost of ribbed slab concrete	57
3.7.	Analysis sheet for total cost of pre-cast beam (6m)	58
3.8.	Analysis sheet for total cost of pre-cast beam (2m)	59

<u>LIST OF FIGURE</u>	<u>PAGE</u>
1.1. Section and Elevation of pre-cast beam	3
1.2. Section of Slab at initial condition before concreting	4
1.3. Section of slab at final condition	4
1.4. Model for analysis and design	7
1.5. Stress and strain profile for pre-cast concrete block	8
1.6. Strain profile	10
1.7. Two point Loading	11
1.8. Moment capacity of upper part of the pre-cast beam	14
1.9. Reinforcement welded at all nodes	43
1.10. Pre-cast beam- slab prior to concreting	43
2.1. Bending Test set up	30
2.2. Uncracked section of the pre-cast beam	32
2.3. Cracked section of the pre-cast beam	33
2.4. Bending of the main reinforcement	44
2.5. Concrete mixing using mechanical mixer	44
2.6. Reinforcement welded and put in the mould	45
2.7. Concrete placing	45
2.8. Vibrating table	46
2.9. Transporting the pre-cast beam using manual cranes	46
2.10. Buckled stirrups	47
2.11. Experimental Load- Deflection Graph (PCB-1)	48
2.12. Experimental load Deflection Graph (PCB-2)	48
2.13. Experimental Load Deflection Graph (PCB-3)	49
2.14. Experimental Load Deflection Graph (PCB-4)	49
2.15. Experimental Load Deflection Graph (PCB-5)	50
2.16. Experimental Load Deflection Graph (PCB-6)	50
2.17. Experimental and Theoretical Load-Deflection Graph (PCB-1)	51
2.18. Experimental and Theoretical Load-Deflection Graph (PCB-4)	51
2.19. Typical 1 st , 2 nd ,3 rd & 4 th Floor Pre-cast Beam-Slab	25
2.20. Typical 1 st ,2 nd ,3 rd & 4 th Floor Solid Slab	26

NOTATIONS

Φ	Diameter of reinforcement bars
f_{yk}	The characteristic strength of reinforcement of steel
f_{ck}	The characteristic cylinder compressive strength of concrete
f_{ctk}	The characteristic cylinder tensile strength of concrete
f_{cd}	The design strength of concrete
f_{yd}	The design strength of steel in tension and compression
f_{ctm}	The mean cylinder tensile strength of concrete
f_{ctd}	The design strength of concrete in tension
h_s	Height of PCB above the pre-cast block
$Y_c Y_s$	Partial safety factors for concrete and steel, responsibility
H	Depth of pre-cast block
PCB	Pre-cast beam
HCB-	Hollow concrete block
Y_{HCB}	Unit weight of hollow concrete blocks
C_c	Compressive force in the concrete
C_s	Compressive force in the reinforcement
τ_s	Longitudinal shear force in the legs of the stirrups
d	effective depth for be pre-cast concrete block
d^1	Concrete cover to the center of the reinforcement bars
C	Neutral axis depth of the pre-cast block from the top fiber
ϵ_s	strain is the steel reinforcement
ϵ_{cu}	Maximum compressive strain in the concrete
T_s	Tensile force in the reinforcement bars
τ_s	Longitudnal shear in the legs of the shear reinforcement
A_s	Area of tensile reinforcement bars

A_s^1	Area of compression reinforcement bars
e_{yd}	Design yield strain of the reinforcement bar
$M_{U,T}$	Theoretical moment capacity of the PCB
E_s, E_C	Modulus of Elastic ties of steel and concrete respectively
ΔM	Moment capacity of the part of the PCB above the pre-cast block
$M_{u,exp}$	Experimental moment capacity of the PCB.
N_{co}, R_d	Compression resistance of axially loaded compression members
N_b, R_d	Buckling resistance of axially loaded compression members
X	Reduction factor for the relevant lucking made
X	Slenderness ratio
L_e	Effective length
R	Radius of gyration
R_{agg}	Unit weight of aggregates
$r_{f,agg}$	Unit weight of fine aggregates
$V_{wate}, V_{cem}, V_{agg}, V_{arr}$	Volume of water, cement, aggregate and air respectively
W_{agg}	Weight of aggregate
$W_{F,agg}, W_{c,agg}$	Weight of fine and coarse aggregate
M_{cr}	Cracking moment
n	Modular ratio
Δ_{ic}	Deflection of the cracked section
Δ_{it}	Deflection of the untracked section
\bar{x}	Neutral axis depth
I	Moment of ine

TABLE OF CONTENTS

PAGE

Acknowledgement	I
Abstract	II
List of tables	III
List of figures	IV
Notations	VI
Table of contents	VIII
1.0. Introduction	1
1.1. General	1
1.2. Objective of the study	2
1.3. The pre-cast beam slab	2
1.4. Theoretical investigations	3
1.4.1. General	3
1.4.2. Design constants	5
1.4.3. Modeling and Analysis	6
1.4.3.1. Analysis of pre-cast concrete block	7
1.4.3.2. Prediction of Buckling Resistance of Stirrups	14
2.0. Materials and their Quality	16
2.1. Materials	16
2.2. Material Quality Test	16
2.2.1. Test to determine the specific gravity of coarse aggregate	17
2.2.2. Test to determine the specific gravity of Fine aggregate	18
2.2.3. Test for sieve analysis of Fine and Coarse aggregate	18
2.2.4. Test to determine Tensile Strength of Reinforcement bars	19
2.3. Consistency and Compressive Strength of concrete	20
2.3.1. Consistency of concrete	20

2.3.2. Compressive strength of concrete	20
2.4. Solid Slab Design	22
2.4.1. Guide for reading analysis and design template	23
2.5. Pre-cast beam production and bending test	29
2.5.1. Pre-cast beam production	29
2.5.2. Bending Test	29
2.6. Computation of Deflections	30
2.6.1. Theoretical deflection of pre-cast concrete block	31
3.0. Cost comparison	35
3.1. Calculation of Quantities of materials	35
3.1.1. Quantities for pre-cast beam slab system	35
3.1.2. Quantities for solid slab system	35
3.2. Cost calculation	37
4.0. Conclusions and Recommendations	38
4.1. Conclusion	38
4.2. Recommendation	38
5.0. References	52
6.0 Appendix-A	53
Appendix-A Sampels on Loading for Critical condition	53

1.0 INTRODUCTION

1.1 GENERAL

Housing is a basic human need. It concerns almost every citizen of the world. There is acute shortage of housing of adequate quality in Ethiopia. The shortage of housing is increasing every year as the house building activity can not cope with the rate of increase in population. If the present housing conditions are not to be allowed to deteriorate further, it is necessary to keep on for a large scale mass housing program without any delay. How can this be done under the present economic conditions when there is an acute shortage of the required resources like finance and building materials? The only way to maximize production of housing would be by making optimum use of the available resources and stretch them to the maximum extent possible, through adoption of a technology appropriate to the present circumstances.

Appropriate cost-effective technology should make most effective use of available resources and result in the maximum overall benefits to the society at minimum costs. Cost-efficiency is one of the most crucial points of low-cost housing. It can mainly be achieved by standardization of building elements and reducing the number of different items needed. Pre-fabrication and the use of special tools to produce these standardized elements maximize productivity, resulting in lower cost per unit.

Through intelligent dual-usage of building elements as building part and as formwork the construction costs are reduced. In the construction process, the amount of wasted materials for formwork can be reduced as well the time for building and dismantling formwork.

1.2 OBJECTIVE OF THE STUDY

The main objective of the present study is to carry out experiments to investigate the response of pre-cast beams commonly used in construction and come up with a theoretical model that can predict the behavior in the ultimate limit for initial loading condition.

In addition to the above, cost comparison of floor slabs, analyzed and designed by the normal solid slab system and the pre-cast beam-slab system (designed not by the current model) is made for a four story building.

1.3 PRE-CAST BEAM-SLAB

Pre-cast beam-slab is made of pre-cast reinforced concrete beam together with hollow blocks. Pre-cast beams, together with slab hollow blocks, are laid between supports and used as permanent formwork for an insitu concrete topping. Steel bars, placed in the pre-cast unit, acts as flexural sagging reinforcement, and the bar at the top in the insitu concrete, acts as hogging reinforcement. The triangulated lattices are manufactured from drawn wire spot welded at the top and bottom reinforcement as shown in Fig.1.90. The primary tasks of these triangulated lattices are to carry the vertical shear or as dowel. During erection the pre-cast beam elements are placed at certain intervals on already casted girder beams. After the hollow concrete blocks are laid across the span of the beam elements, concrete will be casted above. Fig.1.10 shows the photograph for construction of pre-cast beam-slab prior to casting of concrete.

In the present study, two types of beam elements, which vary in their spans, are used. The beams were produced under laboratory conditions and bending test was conducted.

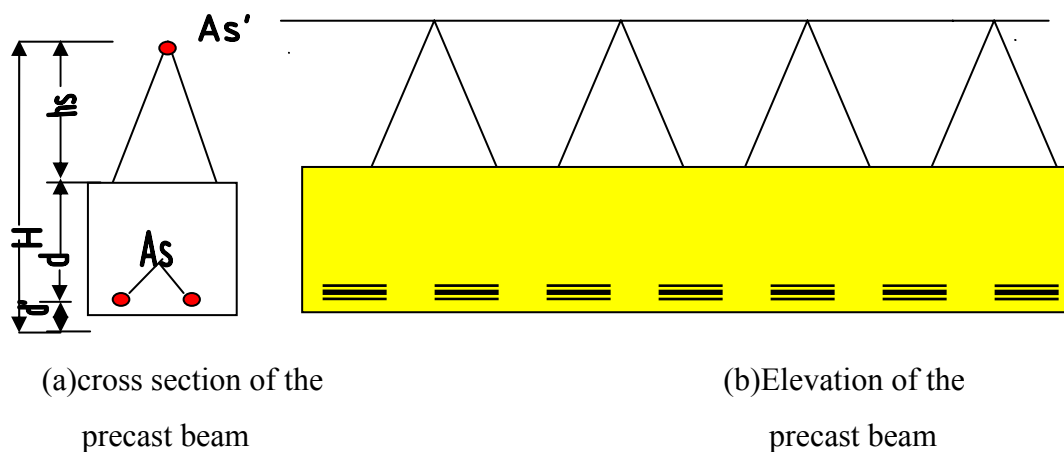

Fig 1.1 Section and Elevation of precast beam

1.4 THEORETICAL INVESTIGATION

1.4.1 GENERAL

Fully cast in place concrete slabs not only require extensive use of soffit formwork and props for casting, but also longer period of time for the removal of the formwork. Thus avoiding the use of formwork in slabs will have the advantage of faster construction with subsequent reduction in the cost of production, reducing the adverse effects associated with deforestation.

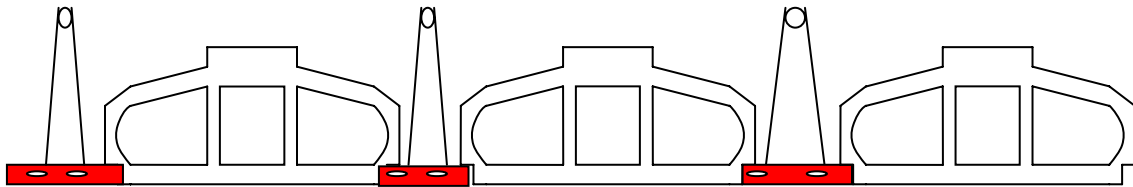

Fig.1.2 Section of slab at initial condition before concreting

One of the most efficient solutions, that have found wide application in many countries, is the use of partially pre-cast beam with shear connectors, as formwork in lieu of timber or steel formwork. In such type of construction, the fresh concrete can be directly poured on the pre-cast beam elements and hollow concrete beam tiles, which bridge the space between them.

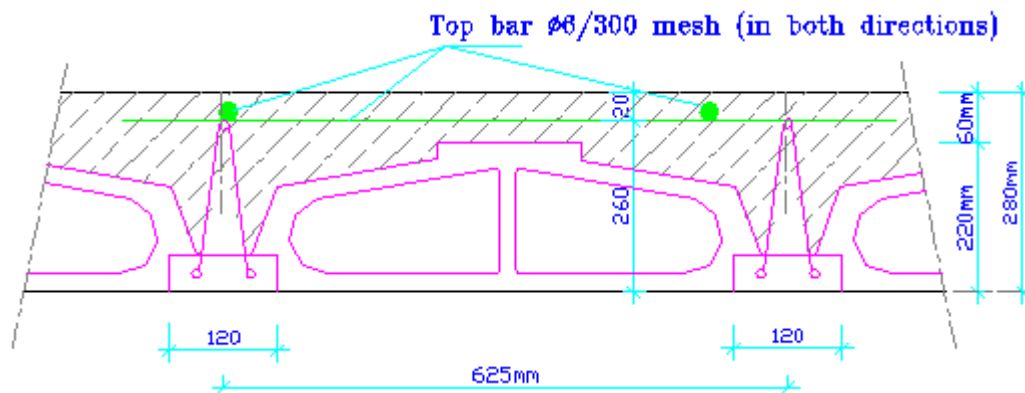

Fig.1.3 Section of slab at final condition

The pre-cast beams must provide adequate strength during all phases of construction. The unit is most critical when the self weight of the wet insitu concrete is added to the self weight

of the pre-cast plank and the slab hollow concrete block as shown in Appendix-A(for a sample of precast beam).

The strength of the pre-cast beam-slab system depends on the strength of the individual pre-cast units and cast insitu concrete.

Failure of a pre-cast beam might occur due to;

1. Yielding of the tensile (bottom) reinforcements in the pre-cast concrete block.
2. Crushing of the pre-cast concrete block under compression.
3. Failure of triangulated stirrups (buckling failure).
4. Buckling of the Compression (top) reinforcement.
5. Shear Buckling

Depending on the grade of concrete, grade and diameter of reinforcement, dimension of the precast beam used to produce the precast beam.

To avoid brittle, potential catastrophic failures, ductile yielding of the bottom reinforcement is the preferred failure mechanism for the final phase of the precast beam.

The effect of buckling of the triangulated stirrups in the capacity of the pre-cast beam is not insignificant not to be considered. In fact, the diameter and clear height of the shear reinforcement limits the strength against buckling failure.

The experimental results have shown that near to the ultimate loading the stirrups buckle pronouncedly thereby undermining the role as shear connectors as shown in Fig2.10 . The result is the loss of (full) interaction between the pre-cast concrete block and the top reinforcement of the pre-cast beam element at loads near to its ultimate.

1.4.2 DESIGN CONSTANTS

MATERIALS

●Concrete C-25

According to EBCS-2, 1995, Eqs. 3.4 and 3.5, the design strength of concrete is given as,

$$f_{cd} = 0.85 \frac{f_{ck}}{\gamma_c} \quad \text{and} \quad (1.1)$$

$$f_{ctd} = \frac{f_{ctk}}{\gamma_c} \quad (1.2)$$

Where:

f_{ck} , f_{ctk} – are the characteristic cylinder compressive and characteristic tensile strength of concrete respectively.

For C – 25, $f_{ck} = 20\text{MPa}$

$$f_{ctk} = 1.5 \text{ MPa}$$

γ_c – partial safety factor for concrete

(for class – I works, $\gamma_c = 1.5$. . . Table 3.1 EBCS2, 1995)

Hence,

$$f_{cd} = \frac{0.85 * 20}{1.5} = 11.33\text{MPa}$$

$$f_{ctd} = \frac{1.5}{1.5} = 1.0\text{MPa}$$

● Steel S.400

According to Eq 3.6 of EBCS 2,1995

$$f_{yd} = \frac{f_{yk}}{\gamma_s} \tag{1.3}$$

Where:

f_{yk} – the characteristic yield strength of reinforcing steel

(For S-400, $f_{yk} = 400 \text{ Mpa}$)

γ_s – Partial safety factor for reinforcing steel

(for class I works, $\gamma_s = 1.15$. . . Table 3.1 EBCS2- 1995)

Hence

$$f_{yd} = \frac{400}{1.15} = 347.83\text{MPa}$$

The modules of Elasticity of the reinforcing steel and concrete are taken as 200 GPa and 29 GPa, respectively, according to articles 2.9.4 and 2.5.2 of EBCS – 2 – 1995.

1.4.3 MODELING AND ANALYSIS

The moment capacity of pre-cast beam consists of two parts,

- I. Moment from couple, which consists of compression from the upper fibers of pre-cast concrete block stressed under compression together with tension from the tensile reinforcement at the bottom.
- II. Moment from the couple, which consists of compression from the top reinforcement and tension from the longitudinal shear that arises in the legs of shear reinforcements just above the pre-cast concrete block.

as shown below

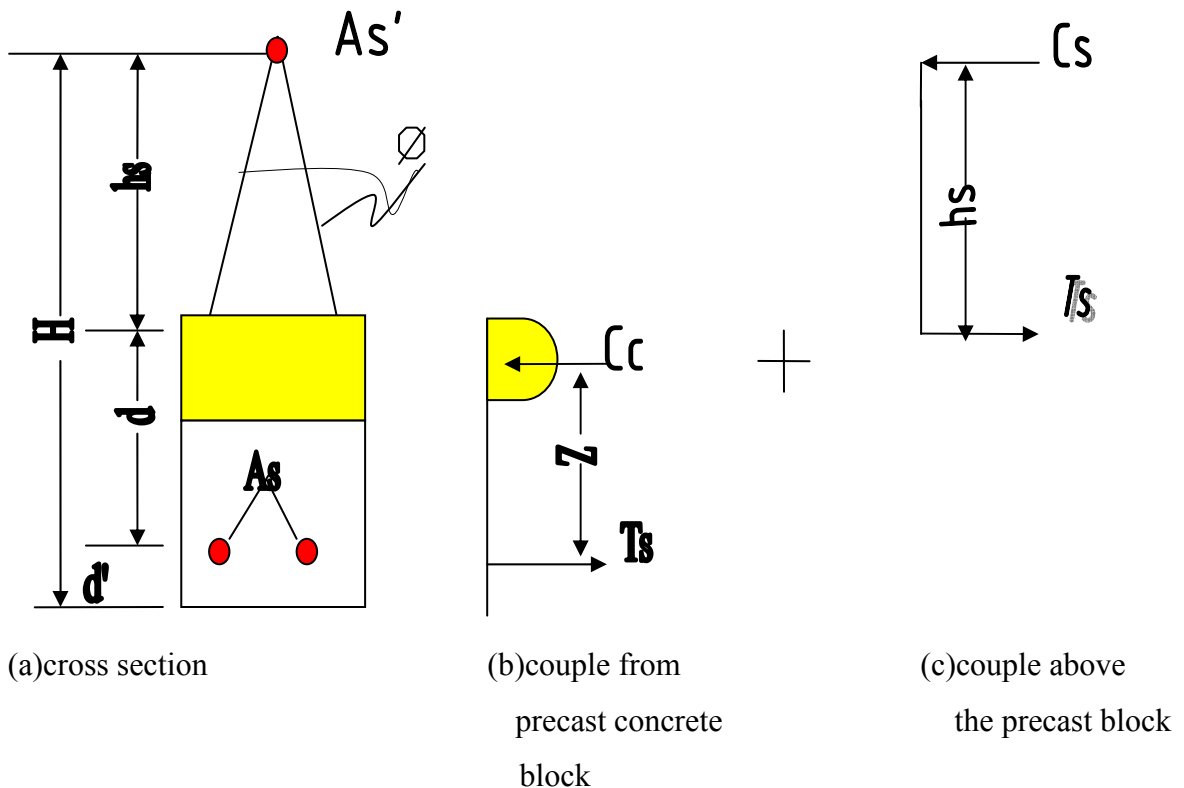

Fig 1.4 Model for Analysis and Design

1.4.3.1 ANALYSIS OF PRE-CAST CONCRETE BLOCK

From experimental observation, failure of the pre-cast block occurs (after pronounced buckling of stirrups) by crushing of the top fibers of concrete. For compression failure, the criterion is that the compression strain in the concrete becomes $\epsilon_{cu}=0.0035$. The steel stress f_s , not having reached the yield point, is proportional to the steel strain ϵ_s ,

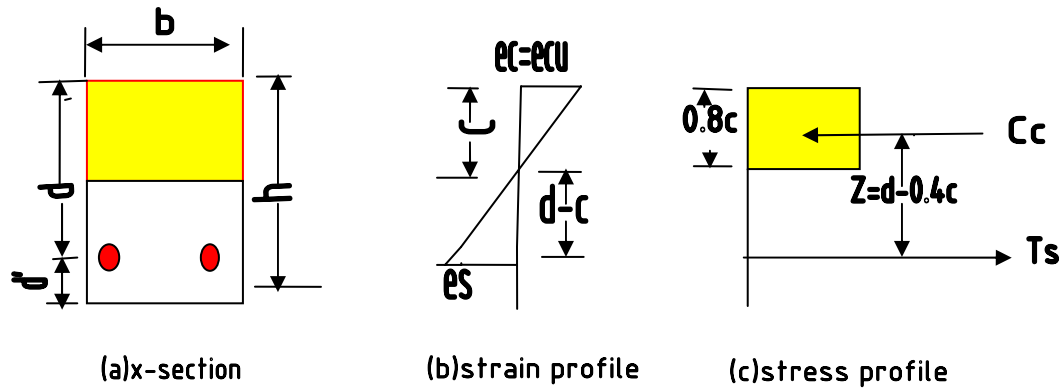

Fig 1.5 Stress and Strain Profile for Precast Concrete Block.

i.e., according to Hooke's Law (1.4)

$$f_s = \epsilon_s \cdot E_s$$

From the strain distribution, by evaluating similar triangles,

$$\epsilon_s = \epsilon_{cu} \frac{d - c}{c} \quad (1.5)$$

Equilibrium requires that

$$C_c = T_s \quad \text{or}$$

$$0.8C \cdot b \cdot f_{ck} = A_s f_s \quad (1.6)$$

Since, $f_s = \epsilon_{cu} \cdot E_s \cdot (d - c / c)$ from (1.4) and (1.5).

Substitution in (1.6) for ' f_s '

$$0.8 \cdot C \cdot b \cdot f_{ck} = A_s \cdot [\epsilon_{cu} \cdot E_s \cdot (d - c / c)] \quad (1.7)$$

and the quadratic may be solved for 'C'.

Finally, check whether $\epsilon_s < \epsilon_y$

The ultimate moment of the precast block that failure occurs by crushing of concrete, may be found

$$M_{u,T} = Cc * Z \text{ or}$$

$$M_{u,T} = T_s * Z \tag{1.8}$$

Where, $M_{u,T}$ – ultimate moment for the pre-cast block found theoretically.

If we designate ‘ $M_{u, exp}$ ’, the capacity of the pre-cast beam determined experimentally.

$$\Delta M = M_{u,exp} - M_{u,T} \tag{1.9}$$

Where, ‘ ΔM ’ is nothing but couple generated from compression from top reinforcement and tension from the longitudinal shear that occurs in the legs of the shear reinforcement just above the pre-cast block.

From Fig. 1.4

$$\Delta M = C_s * h_s \text{ or} \tag{1.10}$$

$$\Delta M = \tau_s * h_s$$

whichever is smaller (since failure may be initiated by either the stirrup or the top reinforcement)

$$c_s = \Delta M / h_s \tag{1.11}$$

According to EBCS 3,1995 Eq. (4.33),

The value found for ‘ C_s ’ should be checked against

- (i) Compression resistance and
- (ii) Bulking resistance

For the cross – section to be analyzed,

$$b = 120\text{mm} \qquad h = 80\text{mm}$$

$$d = 60\text{mm} \qquad d_1^1 = 20\text{mm}$$

$$A_s = 226\text{mm}^2 \qquad A_s^1 = 113\text{mm}^2$$

Substituting in eq (1.7)

$$0.8 * C * 120 * 20 = 226 * [0.0035 * 200,000 * 60 - c/c]$$

$$\Rightarrow C = 40.29\text{mm}$$

Check the strain in the reinforcement from similarity of triangles,

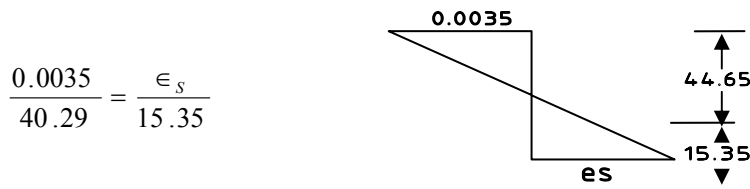

Fig1.6 Strain Profile

$$\epsilon_s = 0.0013 < 0.0017 = \epsilon_y$$

Therefore failure is initiated by compression failure of concrete.

From Eq. 1.6,

$$C_c = 0.8cbf_{ck}$$

Note: The unfactored material strengths are used in order to the values to be compared with the experimental values.

$$\begin{aligned} &= 0.8 * 40.29 * 120 * 20 \\ &= 77.36\text{kN} \end{aligned}$$

and from Fig 1.4

$$\begin{aligned} z &= d - 0.4c \\ &= 60 - 0.4 * 40.29 \\ &= 43.88\text{mm} \end{aligned}$$

The moment capacity, $M_{u,T}$,

$$\begin{aligned} M_{u,T} &= C_c * Z \\ &= 77.36 * 0.044 \\ &= 3.39\text{kN-m} \end{aligned}$$

The capacity of the pre-cast beam found experimentally,

$$M_{u, \text{exp}} = \frac{\left(\frac{p}{2}\right)L}{3} \quad (1.11)$$

$M_{u, \text{exp}}$, “ ΔM ” and “ C_s ” are determined for each beam in Table 1.1 below.

Note that from eq1.9,

$$\Delta M = M_{u, \text{exp}} - M_{u,T}$$

and from eq1.11,

$$C_s = \frac{\Delta M}{hs}$$

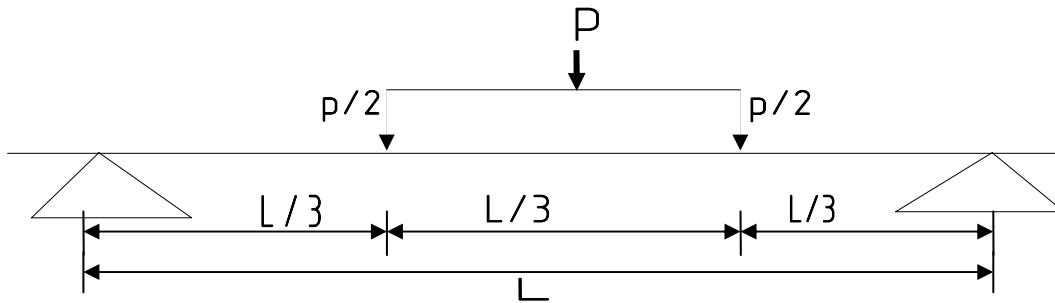

Fig1.7 Two Point Loading

Table 1.1 Average Values of “ΔM” and “Cs”

Pre-cast Beam	Span- L (m)	Pmax (KN)	Mu,exp (KN-m)	ΔM (KN-m)	Cs (KN)	ΔMave (KN-m)	Cs,ave (KN)
PCB1	3.60	6.5	7.8	4.41	24.45	4.55	25.26
PCB2	3.60	6.6	7.92	4.53	25.17		
PCB3	3.60	6.75	8.1	4.71	26.17		
PCB4	3.00	6.7	6.75	3.36	18.67	3.76	20.89
PCB5	3.00	7.35	7.35	3.96	22.00		
PCB6	3.00	7.35	7.35	3.96	22.00		

Check ‘Cs’ against

(I)compression resistance

$$N_{com,Rd} = A_s \cdot f_y$$

$$= 113 \cdot 400$$

$$= 45.20 \text{ KN} > N_{com, Sdmax} = 26.17 \text{ KN (OK)}$$

(II)Buckling Resistance, Nb, Rd

$$N_{b,Rd} = \chi \beta_A A f_y$$

$\beta_A = 1$ for class-1 cross section

$$A_s^1 = \pi \cdot (12)^2 / 4 = 113 \text{ mm}^2$$

and,

$$x = \frac{1}{\phi + (\phi^2 - \bar{\lambda}^2)^{0.5}} \quad \text{but } x \leq 1$$

$$\bar{\lambda} = \left(\frac{\lambda}{\lambda_1} \right) (\beta_A)^{0.5}$$

$$\begin{aligned} \varepsilon &= (235/f_y)^{0.5} \\ &= (235/400)^{0.5} = 0.77 \end{aligned}$$

$$\begin{aligned} \lambda_1 &= 93 * \varepsilon = 93 * (0.77) \\ &= 71.28 \end{aligned}$$

$$\lambda = Le/i$$

$$i = \sqrt{I/Le}, I = \pi * r^4 / 4 = \pi * (12)^4 / 4 = 16286.02 \text{ mm}^4$$

$$i = \sqrt{16286.02/150} = 10.42$$

$$\lambda = 150/10.42 = 14.40$$

$$\bar{\lambda} = (14.40/71.28) * (1)^{0.5} = 0.20$$

$$\begin{aligned} \phi &= 0.5 \left[1 + \alpha (\bar{\lambda} - 0.2) + \bar{\lambda}^2 \right] \\ &= 0.5 * [1 + 0.49(0.2 - 0.2) + 0.2^2] = 0.53 \end{aligned}$$

$$x = \frac{1}{\phi + (\phi^2 - \bar{\lambda}^2)^{0.5}} \quad \text{but } x \leq 1$$

$$= 1 / [0.53 + (0.53^2 - 0.20^2)^{0.5}]$$

$$= 0.98$$

Therefore,

$$N_{b,rd} = X \beta_a A_s^1 f_y$$

$$= 0.98 * 1 * 113 * 400 = 38.52 \text{ KN} \geq C_s, \text{ max} = 33.33 \text{ KN [OK]}$$

Note that “ΔM” varies with the depth of the upper part of the pre-cast beam, span of the pre-cast beam, grade and diameters of reinforcement.

The experiment was conducted for two types of pre-cast beam which varies only with their span (other variables constant).

From Table 1.1, it can be seen that,

$$\left. \begin{array}{l} \Delta M_{ave}=4.55\text{KN-m} \\ C_{s,ave}=25.26\text{KN-m} \\ \text{and,} \end{array} \right\} \text{ For span of 3.00m}$$

$$\left. \begin{array}{l} \Delta M_{ave}=3.76\text{KN-m} \\ C_{s,ave}=20.89\text{KN-m} \end{array} \right\} \text{ For span of 3.60m}$$

Note that ΔM does not vary with span length, but an experimental result makes it to vary. As can be seen from Fig 1.4, " ΔM " is limited by the smaller of " C_s " or " τ_s " which in turn " τ_s " is limited by the buckling resistance of the legs of the stirrup. The longitudinal shear " τ_s " which is the horizontal component of the maximum axial load that the legs of the stirrup can withstand, may be taken as the buckling resistance of the legs of the triangulated stirrups. In fact it is difficult to determine analytically the load at which buckling failure of the stirrups occur, structural software like SAP 2000 can be used to analyze the truss **3D-frame** by loading successively with higher loads until buckling failure of the legs of the stirrups occur. In analyzing the truss the actual uniformly distributed load on the pre-cast beam element is converted into equivalent concentrated loads at the joints.

1.4.3.2 PREDICTION OF THE BUCKLING RESISTANCE OF STIRRUPS.

Using SAP 2000, loading the frame (by successively increasing the diameter of the part of the stirrups embedded in the precast block) with successively higher loads until the mode of failure changed from failure of stirrup to failure of top reinforcement and found to be, $d_{st}=4x d_o$.

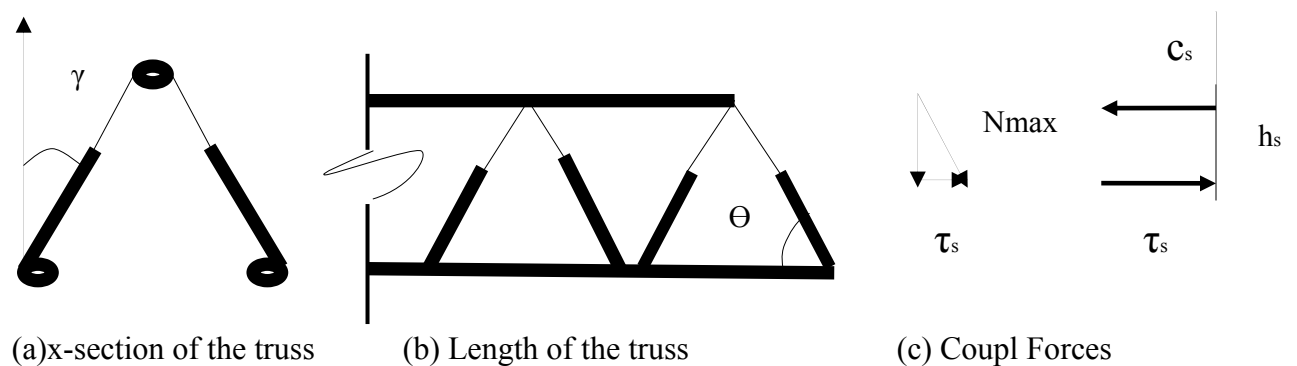

Fig1.9 Moment Capacity of upper part of the pre-cast beam

Note that the depth of the precast concrete which is effective while the beam is loaded is lower than the actual depth due to tension stiffening effect. However, in this analysis the full depth is taken for simplicity.

The maximum axial forces that the legs can withstand were recorded as;

For L = 3.00m, $N_{1max} = 1.097\text{kN}$

For L = 3.60m, $N_{2max} = 1.305\text{kN}$

As can be seen from Fig1.9, the horizontal component of the axial load contributes to the limitations for the moment capacity of the upper part of the pre-cast beam “ ΔM ” and is found to be,

$$\tau_s = 2 * \{N_{max} * \cos\gamma\} \cos\Theta$$

$$\text{where } \Theta = \tan^{-1}(240/75) = 72.64^\circ \text{ and } \gamma = \tan^{-1}(40/240) = 9.46^\circ$$

$$\text{For } L = 3.00\text{m, } \tau_{s1} = 0.650\text{kN}$$

$$\text{For } L = 3.60\text{m, } \tau_{s2} = 0.768\text{kN}$$

Since $\tau_s < CS$ for both spans, the moment capacity of the upper part of the pre-cast beam is governed by the buckling resistance of the triangulated stirrups.

$$\Delta M = \tau_s \times h_s \quad \text{where } h_s = 180\text{mm}$$

$$\text{For } L = 3.00\text{m,}$$

$$\Delta M = \tau_{s1} \times h_s = 0.12\text{KN-m}$$

$$\text{For } L = 3.60\text{m}$$

$$\Delta M = \tau_{s2} \times h_s = 0.14\text{KN-m}$$

From the results found for ΔM from Table 1.1 (based on cs) and above (based on τ_s), ΔM is governed by τ_s . Therefore, the capacity of the precast beam can be taken as the superposition of the capacities of the precast block and the part above it.

$$\begin{array}{l} \text{Moment capacity} \\ \text{of} \\ \text{the pre-cast beam} \end{array} = \begin{array}{l} \text{Capacity of} \\ \text{the} \\ \text{pre-cast block} \end{array} + \Delta M$$

2.0 MATERIALS AND THEIR QUALITY

2.1. MATERIALS

Pre-cast beam is a reinforced concrete member made up of steel and concrete. The qualities of steel and concrete should comply with the standard set in Ethiopian Building Code of Practice. Hence, laboratory material tests such as material quality tests for the composition of concrete, tensile strength tests for the steel reinforcement and compressive strength and consistency tests for the mixed concrete must be conducted in order the pre-cast beam to have a desired quality.

2.2. MATERIAL QUALITY TESTS

Four types of tests have been conducted to determine the quality of the constituent materials of concrete and steel. These are specific gravity of coarse aggregate, specific gravity of fine aggregate, sieve analysis for coarse and fine aggregate, silt content of sand and tensile strength of reinforcement bars. Note that the sand and gravel have been thoroughly washed before the test. Test procedures and results of each tests are reported as follows.

2.2.1. EXIPERIMENT TO DETERMINE SPECIFIC GRAVITY OF COARSE AGGREGATE.

- 6kgs of aggregate was selected by quartering from the sample. Materials passing No. 4 (4.75mm) sieve was rejected.
- To remove dust from the surface the sample was troughly washed and dried at a temperature of 110⁰c. Then allowed to cool in air for 2 hrs.
- The sample has been immersed in water for a period of 24hrs.
- The sample was removed from the water and has been rolled in a large absorbent cloth until all visible films of water removed. Then weighed to be 5.6kgs.
- The saturated-surface dried samples was immediately placed in a container and weighed in water. It was recorded to be 3.53kgs

- Bulk specific gravity (SSD) = $\frac{B}{B - C}$

Where,

B = weight of S.S.D. sample in air [g]

C = weight of saturated sample in water [g]

$$= 5.6 / (5.6 - 3.53)$$

$$= 2.70$$

2.2.2. EXPERIMENT TO DETERMINE SPECIFIC GRAVITY OF FINE AGGREGATE.

- 1kg of aggregate was selected from the sample by quartering and dried in a pan at a temperature of 110⁰c. Then, it is allowed to cool and covered with water, and permitted to stand for 18hrs.
- The excess water has been decanted and sample was spread on a flat non absorbent surface to expose to a moving current of air. Then it has been stirred frequently to secure homogeneous drying.
- 500gms of saturated surface dried fine aggregate, which was prepared before, has been introduced into the pycnometer and the pycnometer was filled with water to its 90% of the capacity.
- The pycnometer has been rolled, inserted and agitated to eliminate all air bubbles. The temperature was adjusted by immersing in circulating water, the water level in the pycnometer was brought to its calibrated capacity.
- The total weight of the pycnometer, specimen and water was recorded as 929.70 gms.
- The weight of the pycnometer, filled to its calibration capacity with water, was recorded as 651.90 gms.

$$\text{Bulk specific gravity (S.S.D)} = \frac{500}{B + 500 - C}$$

Where: B = weight of pycnometer filled with water

C = weight of pycnometer with sample and water to calibrated mark [g]

$$= 500 / (651.9 + 500 - 929.7)$$

=2.25

2.2.3 EXPERIMENT FOR SIEVE ANALYSIS OF FINE AND COARSE AGGREGATE.

- 20kg of sample was taken from the pile.
- A representative sample was selected by quartering.
- 5kg was taken from the quartered sample
- The empty sieves have been weighed and the data recorded.
- The 5kg sample was placed on the top sieve (large opening size)
- The sample has been shaken for about 2minutes in a sieve shaker.
- Each sieve with the aggregate retained on it has been weighed and recorded.
- The weight retained on each sieve was recorded.
- The results of the sieve analysis are summarized in Table 2.5 and Table 2.6
- The maximum size of aggregate is the largest size through which at least 90% of the aggregate passes and is recorded as 19mm.

2.2.4. EXPERIMENT TO DETERMINE SILT CONTENT OF SAND AND THE RESULT.

- In a graduated cylinder 30ml of sand was poured.
- 3/4 of the cylinder was filled with water.
- For about a minute the cylinder has been shaken vigorously.
- The cylinder was left for about an hour to allow the silt to settle on the layer of sand.
- Measurement was taken for the amount of fines forming a separate layer on the top of the washed sand to be 6mm.

$$\text{Silt content (\%)} = \frac{\text{amount of silt deposited above the sand}}{\text{amount of clean sand}} \times 100$$

$$=(6.6/30)*100$$

$$=2\% < 6\%$$

2.2.5 EXPERIMENT TO DETERMINE, TENSILE STRENGTH OF REINFORCEMENT BARS.

- The diameter of the three sample test bars (60cm length) was measured using calipers and recorded as in Table 2.4.
- The ends of the test bars were fitted into the grips of the testing machine.
- An increasing axial tensile force was gradually applied on the bar. (The loading and the corresponding elongation at different instants were recorded by the machine).
- The yield strength of each bar was recorded as in Table 2.4 below.

Table 2.1. Yield Strength of main reinforcement bars.

Specimen	Length (cm)	Internal Diameter (mm)	Projected Diameter (mm)	Yield Strength (Mpa)
1	60	11.4	13.6	430.28
2	60	11.4	13.6	435.35
3	60	11.4	13.6	428.56

The average of the three records is taken as,

$$\begin{aligned}f_{y,ave} &= \frac{f_{y1} + f_{y2} + f_{y3}}{3} \\ &= \frac{430.28 + 435.35 + 428.56}{3} \\ &= 431.40 > 400 \text{ MPa}\end{aligned}$$

2.3. CONSISTENCY AND COMPRESSIVE STRENGTH OF CONCRETE

2.3.1. CONSISTENCY OF CONCRETE

Concrete consistency is most frequently measured by the slump test. The test was conducted in the following procedures,

- From concrete mixed for the preparation of test cubes, the cone was filled to about one third of its height and tamped 25 times using tamping rod.
- Two additional layers of equal height (100mm deep) were added and tamped 25 times.

- The surplus concrete, which stuck out of the top, was struck off using steel float.
- The cone was lifted straight up carefully and was turned over and put down next to the mound of concrete. As soon as the cone was lifted the concrete has slumped.
- By resting the tamping rod across the top of the empty inverted cone so that it reached over the slumped concrete, measurement was taken using the ruler from the underside of the rod to the highest point of concrete to be 35mm. That is with in the range 20-100mm,EBCS 2,1995,Table 8.1.

2.3.2. COMPRESSIVE STRENGTH OF CONCRETE

The main measure of the structural quality of concrete is its compressive strength. Tests for this property is made on cube specimens of 150mmx150mx150mm. Impervious molds of this shape were filled with concrete during the operation of placement and vibrated for about 30 seconds to remove air bubbles. After 24 hours the concrete have been removed from the mould and the cubes were moist cured, generally for 28days, and then tested in the laboratory at a specified rate of loading. The compressive strength obtained from such tests is known as the cube strength f_{cu} and is the main property specified for design purpose.

The properties of freshly mixed as well as the resulting hardened concrete are closely associated with the characteristics and relative proportions of component materials. It is therefore obvious that by determining the relative quantities of materials prior to mixing, we can produce concrete of desired properties. This process is known as mix-design. The mix-design for the test cubes were as follows,

According to Table 8.1 of EBCS 2-1995, the quantity of materials used for $1m^3$ of concrete, for nominal maximum size of aggregate (20mm) and medium workability, are given as;

Cement = 365kg

Water cement ratio = 0.50

Fine Aggregate (%) = 30-40, by weight.

The cement used is Ordinary Portland Cement and the material proportions are as follows.

- Cement = 380kg
- Water = 190kg
- Fine Aggregate =35%(by weight)

- Coarse Aggregate = 65%
- Volume occupied by air = 2%

$$\begin{aligned}\gamma_{agg} &= 0.35 \times \gamma_{F,agg} + 0.65 \times \gamma_{C,agg} \\ &= 0.35 \times 1600 + 0.65 \times 1480 \\ &= 1522 \text{kg/m}^3\end{aligned}\tag{2.1}$$

$$1 \text{m}^3 = V_{wat} + V_{cem} + V_{agg} + V_{air}\tag{2.2}$$

$$\begin{aligned}V_{agg} &= 1 - \left(\frac{190}{1000} + \frac{380}{3000} + \frac{2}{100} \right) \\ &= 0.663 \text{m}^3\end{aligned}$$

$$\begin{aligned}W_{agg} &= \gamma_{agg} \times V_{agg} \\ &= 1522 \times 0.663 \\ &= 1009 \text{kg}\end{aligned}\tag{2.3}$$

$$\begin{aligned}W_{F,agg} &= 0.35 \times 1009 \\ &= 353 \text{kg}\end{aligned}$$

$$\begin{aligned}W_{C,agg} &= 0.65 \times 1725 \\ &= 656 \text{kg}\end{aligned}$$

Using the above relative quantities of materials, three test cubes of concrete are casted, moist-cured for 28 days, and then tested at a specified rate of loading. The compressive strengths obtained from the tests are recorded on Table 2.3 below. The mix design proportion used for the production of pre-cast beams are that of the test cubes.

Table 2.2 Compressive strength test results of concrete cubes

Sample No.	Failure Load (KN)	Compressive Stress (Mpa)
1	587.50	26.11
2	643.50	28.60
3	645.50	<u>28.69</u>
Average.		27.80

2.4 SOLID SLAB DESIGN

This section describes about the analysis and design of floor slabs of the solid slab system which were designed for pre-cast beam-slab system. The analysis and design is carried out using Microsoft Excel slab templates as shown in Table 2.3 and 2.4. Note that the analysis and design of the pre-cast system was carried out not by the current model.

2.4.1. GUIDE FOR READING THE ANALYSIS AND DESIGN TEMPLATE

- Panel type case No-refers to the type of panel according to support condition as in Table A-1 of EBCS 2-1995.
- β_a =a Constant from Table 5.1, EBCS2-1995.
- L_x and L_y are the shorter and longer spans of a panel, respectively.
- D and d are the overall and effective depth of a panel, respectively.

$$d = \left\{ 0.4 + 0.6 \times \frac{F_{yk}}{400} \right\} \times \frac{L_x}{\beta_a} \quad (2.4)$$

(Eq. 5.3, EBCS2-1995, part 1)

- D-load refers to the dead load.
- Live load is according to EBCS 1-1995 Table 2.10,
$$q_k = 3.0kN / m^2$$
- Design load = 1.3× D-load +1.6×live load.
- r values are the ratios of negative moment capacity at edges 1 to 4, to the span moment capacity in the same direction. (4/3 for continuous edges and 0 for discontinuous edges.)
- Alpha values
- α_x and α_y are the negative moment coefficients and are taken as 4/3 times the positive moment coefficients for the same direction. The positive moment coefficients are given as:

$$\alpha_{yf} = \frac{24 + 2 \times n_d + 1.5 \times n_d^2}{1000} \quad (2.5)$$

$$\alpha_{xf} = \frac{\beta}{(\sqrt{1+r_3} + \sqrt{1+r_4})^2} \quad (2.6)$$

$$\beta = \frac{2}{3} \left\{ 1 - \frac{L_y}{L_x} \sqrt{2\alpha_{yf}} (\sqrt{1+r_1} + \sqrt{1+r_2}) \right\} \quad (2.7)$$

- n_d is the number of discontinuous edges. ($0 < n_d < 4$)

- Moment

$$M_i = \alpha_i \times q_d \times L_x^2$$

$$K_{mi} = \frac{\sqrt{\frac{M_i}{b}}}{d} \quad (2.8)$$

K_{si} - a coefficient for a value of K_{mi} read from the General Table No. 1a, EBCS 2-1995 part two.

A_{smin} - is the minimum reinforcement area, in mm^2 , given by

$$A_{smin} = \frac{0.5 \times b \times d}{F_{yk}} \quad (2.9)$$

$$A_{scal} = \frac{K_{si} \times M_i}{d} \quad (2.10)$$

A_{sfinal} - the maximum of A_{smin} and A_{scal}

S_{max} - the maximum spacing, in mm, between reinforcing bars, given by

$$S_{max} \leq \begin{cases} 2 \times D \\ 350 \end{cases} \quad (2.11)$$

$$S_{calc} = \frac{b \times a_s}{A_{sfinal}} \quad (2.12)$$

a_s - is the area of one reinforcement bar.

S_{final} - is the minimum of S_{max} and S_{calc}

Assumption

A uniform load q of $q=2.00kN/m^2$ is assumed from partitions, for both systems.

FLOOR- PLAN-RIBBED

FLOORPLAN-

SOLIDPLANS

OLID

Slab-template

Slab-template

2.5 PRE-CAST BEAM PRODUCTION AND BENDING TEST

2.5.1 PRE-CAST BEAM PRODUCTION

Taking the mix design proportion in section 2.3.2, six samples (three for each type) of the pre-cast beam elements are casted in the production center. The steel reinforcement used are that tested in the laboratory (section 2.2.5) for tensile strength and their sizes are, 12mm diameter deformed bars for top and bottom reinforcement and 6mm plain bar for the stirrups as shown in Fig.1.4.

In the pre-cast beam production, the reinforcements were properly bent. The stirrups were welded with the main reinforcement at all nodes. The pre-cast beams were then casted by using a mould and a vibration table (as shown in Figs 2.7 and 2.9) so that the concrete was well compacted. The mould was used to cast four beams at once. The beams produced were transported to the place where they are cured by manual cranes as shown in Fig. 2.10.

2.5.2 BENDING TEST

The test program was intended to study the behavior of pre-cast beam elements in order to investigate the response under load of the pre-cast slab system while the cast insitu concrete is still in its plastic state.

The pre-cast beams were cured three times per day under shade for 14 days and tested for strength after 28 days. The test was conducted with a two point loading system on simple supports. The loading is gradually increased until the pre-cast beam elements reach their ultimate capacity. Fig 2.1 shows a photograph of the test set up.

Six pre-cast beams were tested and for each beam the mid-span deflection and failure load were recorded in Table 2.7. The measurements were taken at intervals of loads increment of 0.05 tons. The results of the experiment showed that the mode of failure for most of the pre-cast beams was the buckling of the triangulated stirrups.



Fig.2.1 Bending Test Setup

2.6. COMPUTATION OF DEFLECTION.

The theoretical computation of deflection have been performed by considering only the precast concrete block (without considering the part above the precast block since I could not quantify the contribution of the upper part in the computation of deflection). Deflections have been found and recorded in Table 2.8.

2.6.1 THEORETICAL DEFLECTION OF PRE-CAST CONCRETE BLOCK.

If the maximum moment in the pre-cast concrete block is so small that the tension stress in the concrete does not exceed the modulus of rupture, f_r , no flexural tension cracks will occur. The full, uncracked section is then available for providing rigidity. The effective moment of inertia for this low range of loads is that of the uncracked transformed section I_{ut} , and E is the modulus of elasticity of concrete $E_c=29\text{GPa}$. Therefore deflection Δ_{iu} is,

$$\Delta_{iu} = -\frac{23PL^3}{648EI_{ut}} \quad (2.13)$$

At higher loads, flexural tension cracks are formed. Flexural tension cracking causes the effective moment of inertia to be that of the cracked transformed section. Thus the deflection Δ_{ic} occurring in the pre-cast beam after cracking moment, M_{cr} , is exceeded can be calculated by using effective moment of Inertia, I_e that is,

$$\Delta_{ic} = -\frac{23PL^3}{648E, I_e} \quad (2.14)$$

Where,

$$I_e = \left(\frac{M_{cr}}{M_{ax}}\right)^3 I_{ut} + \left[1 - \left(\frac{M_{cr}}{M_a}\right)^3\right] I_{cr} \text{ and } \leq I_{ut} \quad (2.15)$$

Where $M_a = \frac{(P/2)L}{3}$, the maximum moment in the beam

I_{cr} = moment of inertia of the cracked transformed section

$$M_{cr} = \frac{f_r I_{ut}}{y_t}, \text{ cracking moment of the section}$$

f_r = modulus of rupture

y_t = the distance from the neutral axis to the tension face

For the cross section to be analyzed,

$$n = \frac{E_s}{E_c} = \frac{200}{29} = 6.9 \quad (2.16)$$

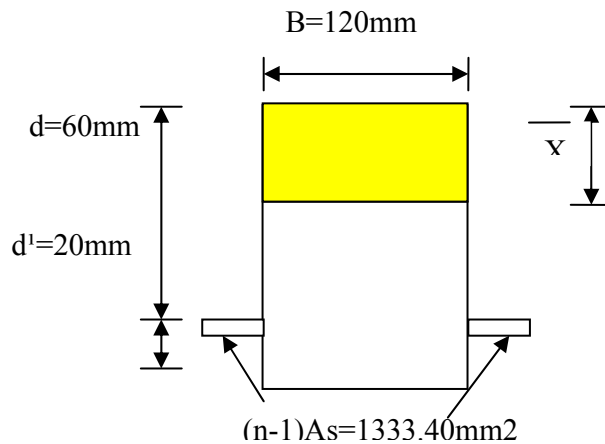

Fig.2.2 Uncracked Section of the pre-cast beam

Depth of neutral axis(uncracked), \bar{x}_u

$$\bar{x}_u = \frac{A_c \left(\frac{H}{2}\right) + [(n-1)A_s]d}{A_c + (n-1)A_s} \quad (2.17)$$

$$\bar{x}_u = \frac{(120 \times 80) \left(\frac{80}{2}\right) + [(6.9-1)226] \times (60)}{(120 \times 80) + [(6.9-1) \times 226]}$$

$$\bar{x}_u = 42.44 \text{mm}$$

$$I_{ur} = \left(\frac{1}{12} \times 120 \times 80^3 \right) + (120 \times 80) \times (42.44 - 40)^2 + \left(\frac{1}{12} \times 111.17 \times 12^3 \right) + (1333.4)(60 - 42.44)^2$$

$$= 5.60 \times 10^6 \text{mm}^4$$

Similarly, the cracked moment of Inertia I_{cr} , be found,

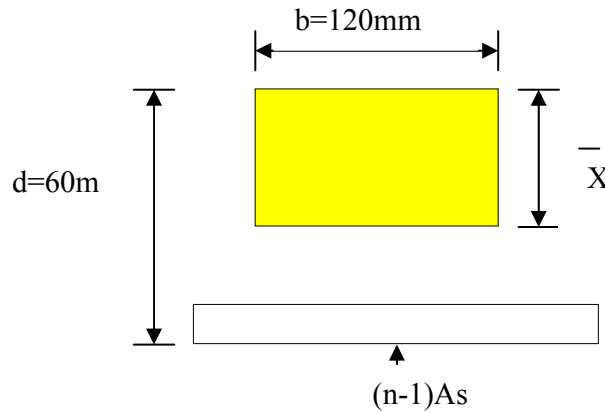

Fig.2.3 Cracked Section of the pre-cast beam

$$(\bar{x}.cb) \left(\frac{\bar{x}}{2}\right) = [(n-1)A_s] \times [d - \bar{x}] \quad (2.18)$$

$$(120\bar{x}c) \left(\frac{\bar{x}}{2}\right) = [(6.9-1)(226)] [60 - \bar{x}]$$

$$\bar{x}_c = 27.06 \text{mm}$$

The cracked moment of Inertia, I_{cr}

$$I_{cr} = \left(\frac{1}{12} \times 120 \times 27.06^3 \right) + (120 \times 27.06) \left(\frac{27.06}{2} \right)^2 + \left(\frac{1}{12} \times 111.12 \times 12^3 \right) + 1333.4 \times (60 - 27.06)^2$$

$$= 2.26 \times 10^6 \text{mm}^4$$

$$\text{The cracking moment } M_{cr} = \frac{f_r I_{ut}}{y_t} \quad (2.19)$$

$$f_{ctk} = 0.7 f_{ctm} \text{ and}$$

According to EBCS2, 1995, Eq 2.1

$$f_{ctm} = 0.3 \cdot f_{ck}^{2/3}$$

For C-28 concrete, $f_{ck}=22.4\text{MPa}$

$$f_{ctm} = 0.3 \times (22.4)^{2/3}$$

$$=2.38\text{MPa}$$

$$f_{ctk} = 0.7 \times 2.38$$

$$=1.67\text{MPa}$$

The modulus of rupture, $f_r=f_{ctd}$,

$$M_{cr} = \frac{(1.11) \times (2.35 \times 10^6)}{37.56}$$

$$=0.17\text{KN-m}$$

The maximum moment 'Ma' for any 'P' is

$$M_a = \frac{(P/2)L}{3}$$

The equivalent cracking Load. P_{cr} is,

$$P_{cr} = 6M_{cr}/L$$

For span $L=3.00\text{m}$

$$P_{cr} = 60.17/3 = 0.34\text{kN}$$

Since "Pcr" is very small for the interval of loading of 0.5kN, take $I_e=I_{cr}$.

and the deflection, Δ_{ic}

$$\Delta_{ic} = -\frac{23 PL^3}{648 E I_e}$$

For $L=3.60\text{m}$,

$$\Delta_{ic} = 25.27P$$

For $L=3.00\text{m}$

$$\Delta_{ic} = 14.62P$$

Where 'Ma' is in N-mm

Having I_{ut} and I_e , the theoretical deflections both prior to crack and after formation of crack were determined and recorded in Table 2.7.

3.0 COST COMPARISON

In this section, the cost of construction, using the two systems, of the four-story building is calculated and comparison of costs is made by calculating the quantities and the current cost of materials.

3.1 CALCULATION OF QUANTITIES OF MATERIALS

Calculation of quantities of materials is done by referring to the floor plans on Fig2.20and2.21.

3.1.1 QUANTITIES FOR PRECAST BEAM-SLAB SYSTEM

- Concrete

- Floor slab: $40[(5.80*3.80)+(1.80*3.80)]*0.094\text{m}^3/\text{m}^2$

- Total volume = 108.59m^3

- Reinforcement

- φ6:

- Floor slab: $0.222*9241.60$

- Total weight= 2051.64kg

- HCB

- Floor slab:

- $9\text{pcs}/\text{m}^2*1155.20\text{m}^2$

- Total: $10,3969.80\text{pcs}$.

Note:The cost of HCB, is taken from the current cost of the suppliers in the market.

3.1.2 QUANTITIES FOR SOLID SLAB SYSTEM

- Concrete

- Floor slab : $40[(3.75*1.75)+(3.75*5.75)]*0.10$

- Total volume = 112.50m^3

- Beams : $4[11*(8.20)+3(40.20)](0.25)*(0.35)$

Total volume =72.76m³

- Formwork

- Floor slab: $40[(3.75*1.75)+(3.75*5.75)]$

- Total area = 1125m²

- Beam

- =4[11(8.20)+3(40.20) +(3.75*5.75)]

- Total area =800.85m²

- Reinforcement

- φ8:

- Beams: (0.395*4992)1.05

- Sub total =2070.43kg

- φ10:

- Floor slab: (0.617*8167.35)(1.05)

- Sub total =5291.22kg

- φ12:

- Beams: (0.888*3589.92)(1.05)

- Sub total =3347.24kg

- φ14:

- Beams: (1.208*3099.36)(1.05)

- Sub total =3931.23kg

- Total weight: Beams =13837.63kg

Note that the unit rate for the reinforcement is determined based on the cost analysis sheet on Table3.5.

3.2 COST CALCULATION

Table 3.1 Cost calculation using solid slab system

Material	Unit	Quantity	Cost per unit	Cost
Concrete	m3	185.26	991.44	183674.17
Formwork	m2	1925.85	66.70	128454.20
Reinforcement	kg	17516.61	13.86	242780.21
Total cost = 554908.58Birr				

Table 3.2. Cost calculation pre-cast beam - slab system

Material	Unit	Quantity	Cost per unit	Cost
HCB	Pcs	10396.80	7.00	72777.60
Concrete	m3	181.35	991.44	117324.38
Formwork(for beams)	m2	800.85	66.70	53416.70
Reinforcement	kg	9291.85	13.86	128785.08
PCB(6m)	pcs	260	416.43	108271.80
PCB(2m)	pcs	260	161.88	42088.80
Support	pcs	780	18.50	13057.20
Total cost = 535721.56Birr				

The difference in the total cost between the two system is

$$554908.58 - 535721.56 = 19187.02 \text{ Birr}$$

Total area of floors = $4 \times 40 \times 8 = 1280 \text{ m}^2$

Hence the saving per floor area, from construction cost is,

$$= \frac{19187.02}{1280} \cong 14.98 \text{ Birr} / \text{m}^2$$

4.0. CONCLUSION AND RECOMMENDATIONS

4.1. CONCLUSIONS

1. For a country like Ethiopia, where timber resource is limited the application of this system of construction not only has economical benefits but also contributes its own in the battle against deforestation by avoiding excessive use of wooden formwork.
2. As can be seen from the cost comparison the saving in construction cost is 3.46%, which is significant when looked at large scale construction at the country level.
3. From the experiment it has been observed that failure is initiated by buckling of stirrups around the supports where maximum shear and maximum moment acts simultaneously and the mode of failure is shear buckling failure.
4. As can be seen from Fig. 2.17 and Fig. 2.18, the experimental mid-span deflection of pre-cast beam elements obtained from load-deflection test were found to be lower than the theoretically computed values (except for very large loadings after the stirrups fails by shear buckling) for both types of pre-cast beam elements. The discrepancy between the theoretical and experimental values could have been arisen due to the assumption that part of the PCB above the pre-cast concrete block is neglected for the theoretical computation of deflection (since I could not quantify the contribution of the upper part due to shortage of time).
4. As has been seen in section 1.4.3.2, part of the PCB above the pre-cast block is sensitive due to the low buckling resistance of the stirrups. Therefore, the moment capacity of the pre-cast beam (as a whole) is highly influenced by the contribution of part of the PCB above the pre-cast block for the critical loading stage (when wet concrete poured on the pre-cast beams and slab hollow blocks)

4.2. RECOMMENDATION

1. Since failure occurs around the supports where maximum shear and maximum moment simultaneously acts, the capacity of the precast beam can be improved by
 - (i) decreasing the space between the nodes of the stirrups around the support
 - (ii) decreasing the height of the part of the precast above the precast block
 - (iii) increase the diameter of the reinforcement used for the stirrup

2. This study is made mostly on the theoretical or analytical bases with most of the variables are made to be constant, further studies should be done in the laboratory to come to a general relation which can be used for any type of section regardless of any variables.
3. The design of PCB is made under great mathematical precision however during construction (in the production center) there are so many compromises related to quality of ingredients, mix-ratio, etc. These should be amended in order for the building to serve the design purpose.
4. Finally, similar works and extensions of this thesis work can be done in the future for the immense application of partially pre-cast beam slab system in the private sector.
5. These include:-
 - ➔ Preparation of Charts and Tables for analysis and design of partially pre-cast beams.
(In addition to the one published by GTZ in collaboration with MH-engineering)
 - ➔ Provisions for design and construction practice of pre-cast concrete in our codes of practice or prepare code of practice for pre-cast concrete construction.
 - ➔ Detailing of reinforcements around connections between pre-cast elements or between pre-cast elements and cast in place reinforced concrete members.

Table 2.5 Gradation test results of fine aggregate

Sieve size (mm)	Wt. of sieve (gm)	Wt. sieve+Wt. Retained (gm)	Wt. retained (gm)	Percent Retained (%)	Percent coarser (%)	Percent Passing (%)	Grading requirement Percent passing (%)
9.5	597.0	597.0	0	0	0	100	100
4.75	578.2	611.1	32.9	5	5	95	95-100
2.36	531.8	637.6	105.8	15	20	80	80-100
1.18	538.4	670.3	131.9	19	39	61	50-85
0.6	518.3	730.5	212.6	31	70	30	25-60
0.3	488.2	630.5	142.3	20	90	10	10-30
0.15	482.0	527.8	45.8	7	97	3	2-10
Pan	420.0	439.8	19.8	3	100	0	-
Total			691.1				

Table 2.6 Gradation test results of coarse aggregate

Sieve size (mm)	Wt. of sieve (gm)	Wt. sieve+Wt. Retained (gm)	Wt. retained (gm)	Percent Retained (%)	Percent coarser (%)	Percent Passing (%)	Grading requirement Percent passing (%)
25	1190.8	0	0	0	100	-	
19	1426.9	166.9	5	5	95	95-100	
12.5	1193.4	1257.2	41	46	54	-	
9.5	1198.0	412.6	13	59	41	25-55	
4.75	1202.1	1157.1	38	97	3	0-10	
Pan	1064.9	80.3	3	100	0	-	
Total		3083.1					

Note: The grading requirements of fine and coarse aggregate are according to Ethiopian standard, ES C.D3.201, Art. 5.1, Table 3 and ES C.D3.201, Art. 4.1, Table 1, respectively.

Table 2.7 Measured readings of load-deflection tests.

Load (KN)	Deflection Type-1(L=3.60m)			Deflection Type-2(L=3.00m)		
	PCB-1	PCB-2	PCB-3	PCB-4	PCB-5	PCB-6
	(cm)	(cm)	(cm)	(cm)	(cm)	(cm)
0.00	0.00	0.00	0.00	0.00	0.00	0.00
0.50	0.12	0.18	0.12	0.09	0.05	0.10
1.00	0.24	0.23	0.23	0.16	0.13	0.21
1.50	0.35	0.32	0.32	0.21	0.19	0.32
2.00	0.45	0.41	0.41	0.26	0.24	0.42
2.50	0.62	0.50	0.51	0.33	0.30	0.48
3.00	0.69	0.60	0.61	0.39	0.37	0.58
3.50	0.78	0.71	0.70	0.47	0.42	0.68
4.00	0.88	0.80	0.80	0.54	0.47	0.78
4.50	1.01	0.92	0.91	0.60	0.55	0.91
5.00	1.13	1.05	1.01	0.70	0.61	1.08
5.50	1.26	1.21	1.13	0.79	0.69	1.21
6.00	1.38	1.31	1.24	0.88	0.79	1.36
6.50	1.53	1.46	1.38	0.99	0.86	1.53
7.00	1.68	1.61	1.52	1.11	0.96	1.73
7.50	1.85	1.78	1.66	1.23	1.05	1.96
8.00	2.01	1.95	1.83	1.35	1.17	2.21
8.50	2.24	2.14	2.01	1.52	1.28	2.45
9.00	2.65	2.66	2.25	1.68	1.40	2.70
9.50	3.10	2.75	2.39	1.92	1.54	3.20
10.00	3.60	3.20	2.80	2.16	1.69	3.60
10.50	3.90	4.00	3.20	2.54	1.83	4.00
11.00	4.40	5.00	3.60	3.00	2.01	4.30
11.50	5.00	5.60	4.30	3.25	2.18	4.80
12.00	5.70	6.35	5.30	3.70	2.36	5.60
12.50	6.50	7.80	6.10	4.30	2.60	6.00
13.00	7.60	9.30	6.75	5.00	2.90	6.40
13.50		(13.2)10	7.00	8.50	3.10	6.90
14.00					4.00	7.50
14.70					5.00	8.50

Table 2.8 Experimental and theoretical mid span deflection of PCB elements.

Load (KN)	Experimental Deflection (cm)		Theoretical Deflection (cm)	
	PCB-1	PCB-4	PCB-1	PCB-4
0	0.000	0.000	0.000	0.000
0.5	0.120	0.090	0.725	0.101
1.0	0.240	0.160	0.559	0.334
1.5	0.350	0.210	0.767	0.464
2.0	0.450	0.260	0.944	0.577
2.5	0.620	0.330	1.095	0.675
3.0	0.690	0.390	1.225	0.762
3.5	0.780	0.470	1.340	0.838
4.0	0.880	0.540	1.440	0.907
4.5	1.010	0.600	1.530	0.968
5.0	1.130	0.700	1.610	1.023
5.5	1.260	0.790	1.682	1.074
6.0	1.380	0.880	1.747	1.120
6.5	1.530	0.990	1.806	1.162
7.0	1.680	1.110	1.860	1.200
7.5	1.850	1.230	1.909	1.236
8.0	2.010	1.350	1.954	1.269
8.5	2.240	1.520	1.996	1.300
9.0	2.650	1.680	2.035	1.328
9.5	3.100	1.920	2.071	1.355
10.0	3.600	2.160	2.105	1.379
10.5	3.900	2.540	2.136	1.403
11.0	4.400	3.000	2.165	1.424
11.5	5.000	3.250	2.193	1.445
12.0	5.700	3.700	2.218	1.464
12.5	6.500	4.300	2.243	1.482
13.0	7.600	5.000	2.266	1.500
13.5		8.500		1.516



Fig1.9 Reinforcement welded at all nodes.



Fig1.10 Pre-cast Beam-Slab prior to concreting.



Fig.2.4 Bending of the main reinforcement.



Fig. 2.5 Concrete mixing .



Fig. 2.6 Reinforcements welded and put in the mould.



Fig. 2.7 Concrete Placing.



Fig. 2.8 Vibrating Table.



Fig. 2.9 Transporting using manual cranes.

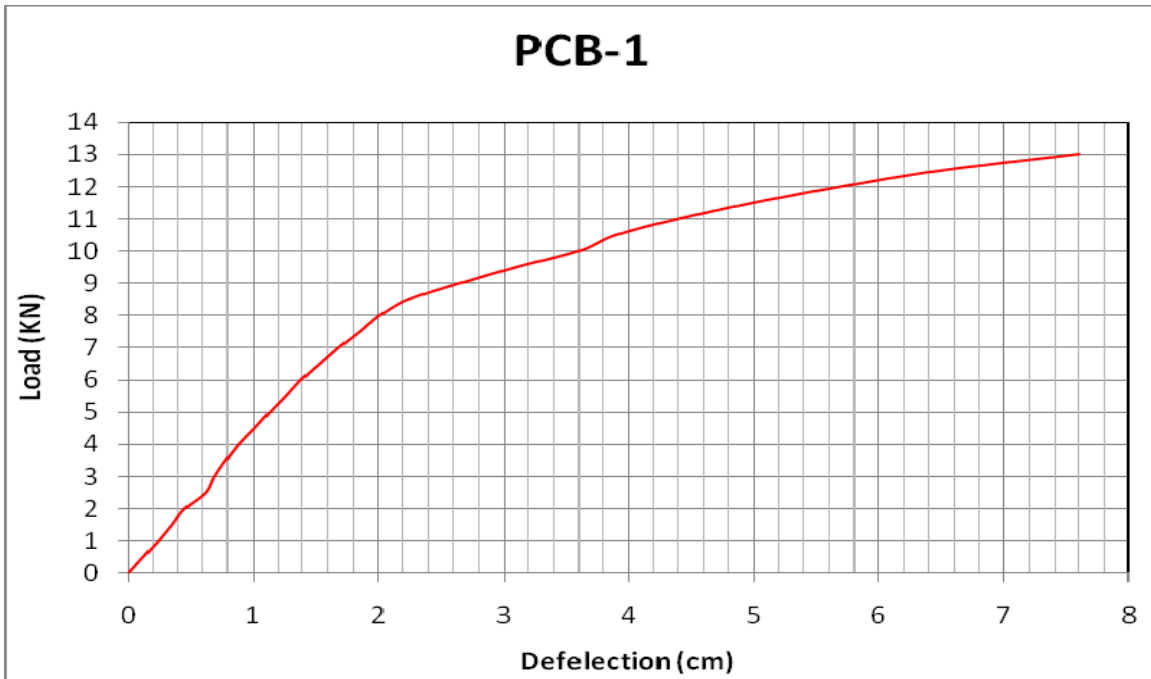

Fig 2.11 Experimental Load-Deflection Graph(PCB-1)

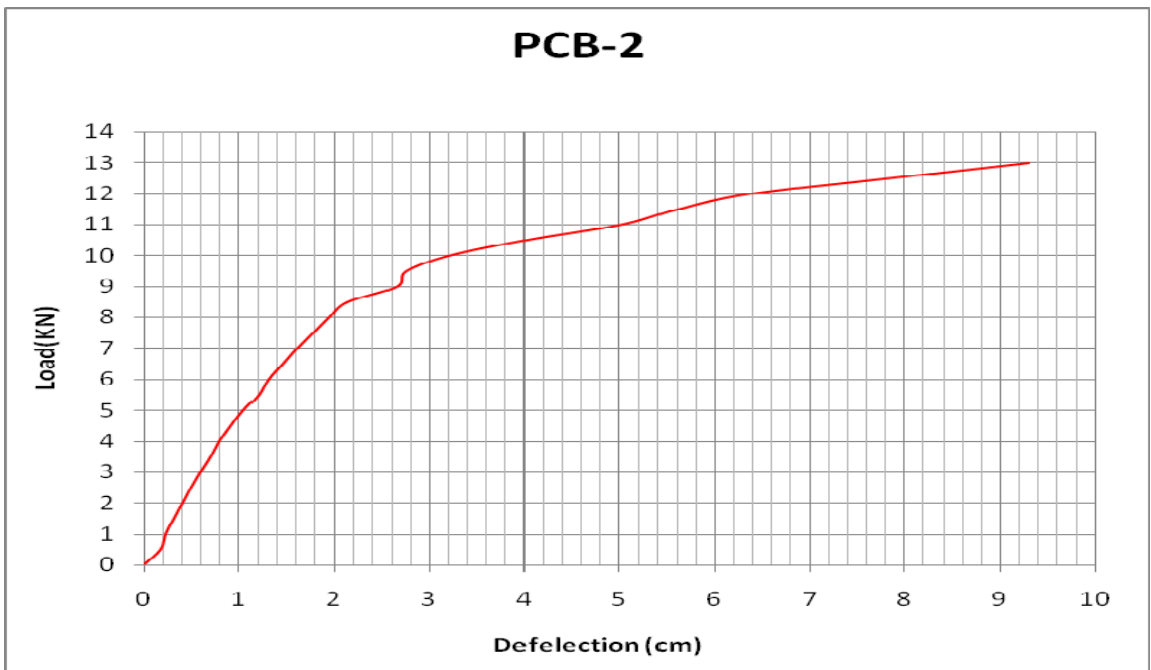

Fig 2.12 Experimental Load-Deflection Graph(PCB-2)

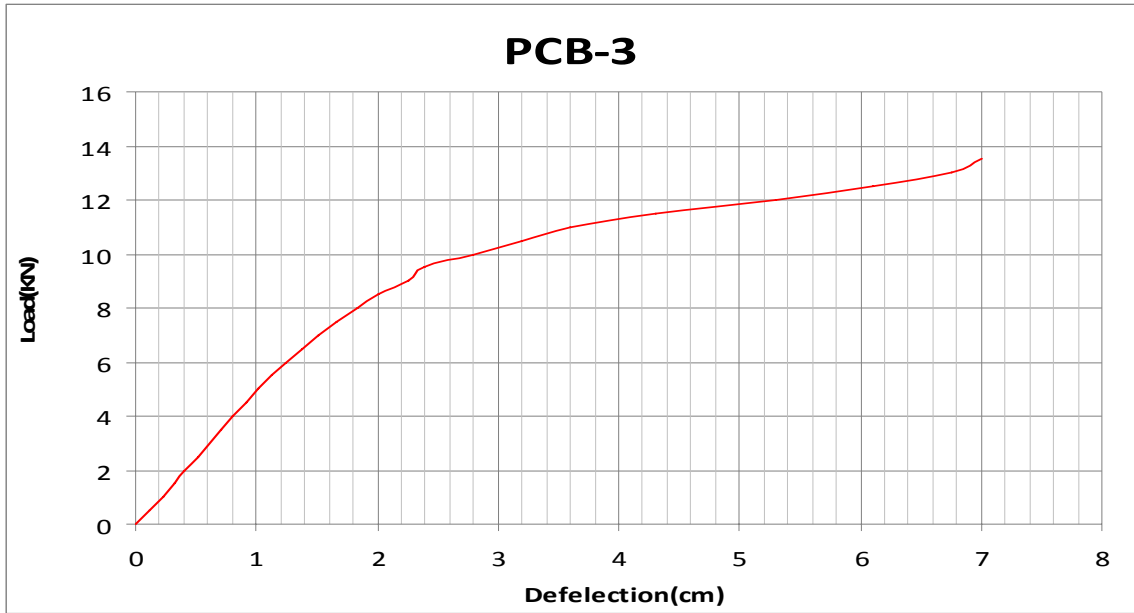

Fig 2.13 Experimental Load-Deflection Graph(PCB-3)

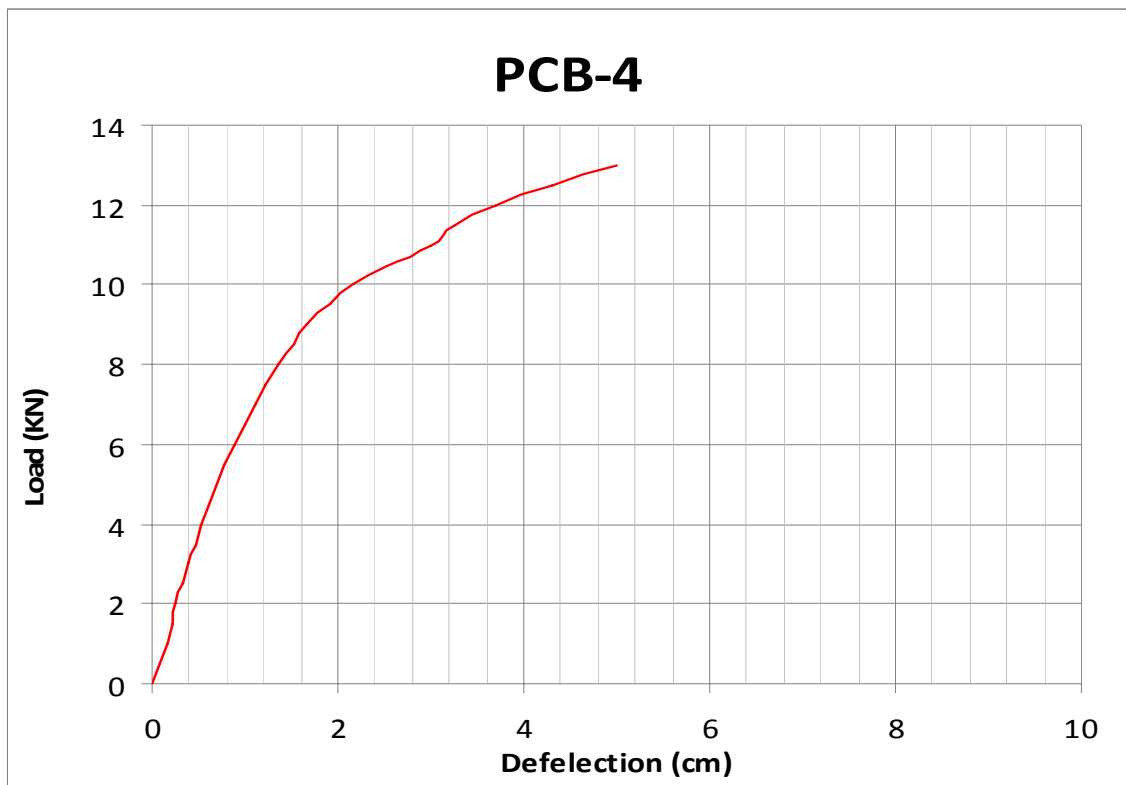

Fig 2.14 Experimental Load-Deflection Graph(PCB-4)

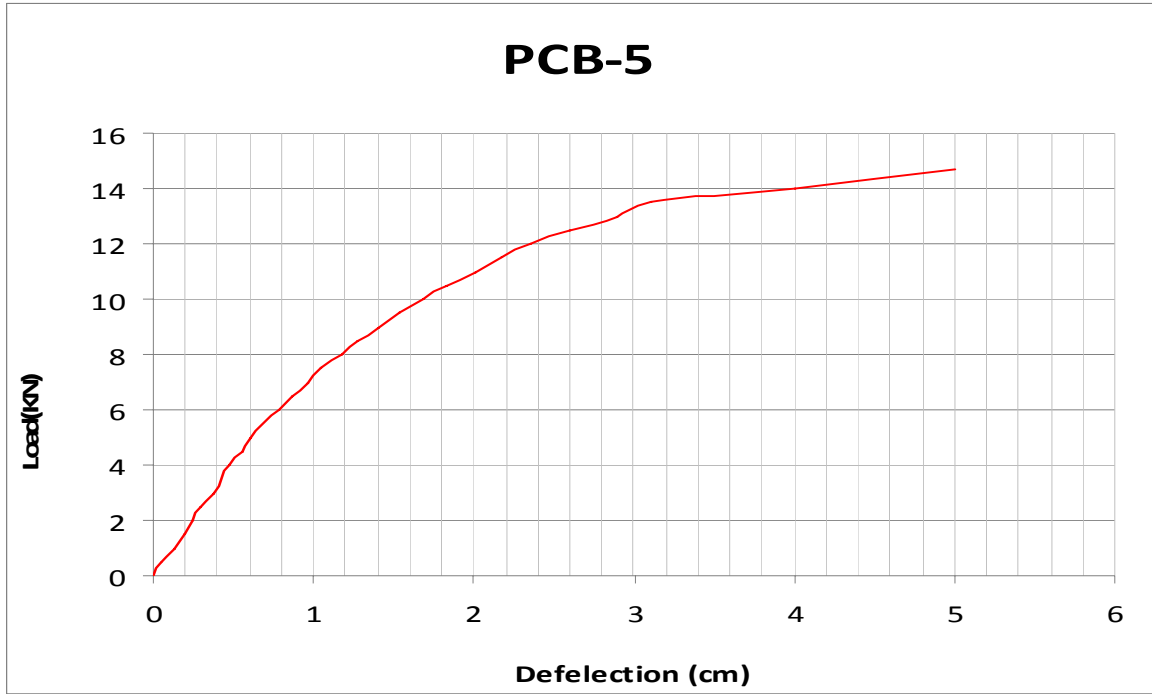

Fig 2.15 Experimental Load-Deflection Graph(PCB-5)

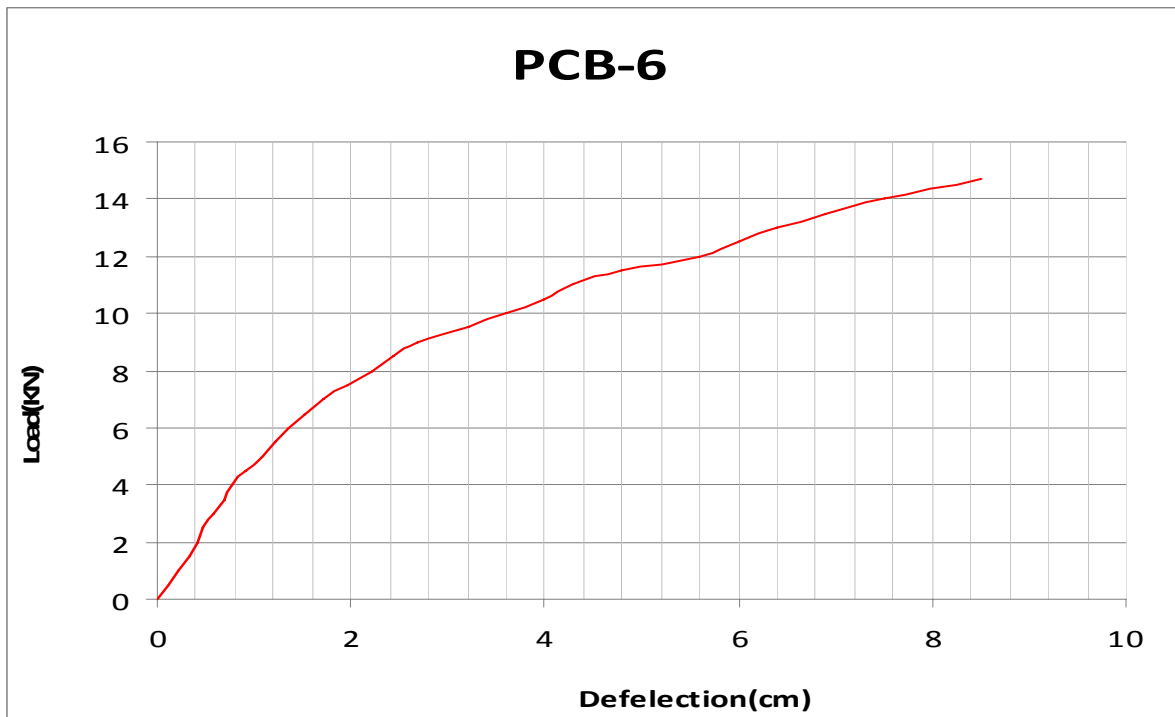

Fig 2.16 Experimental Load-Deflection Graph(PCB-6)

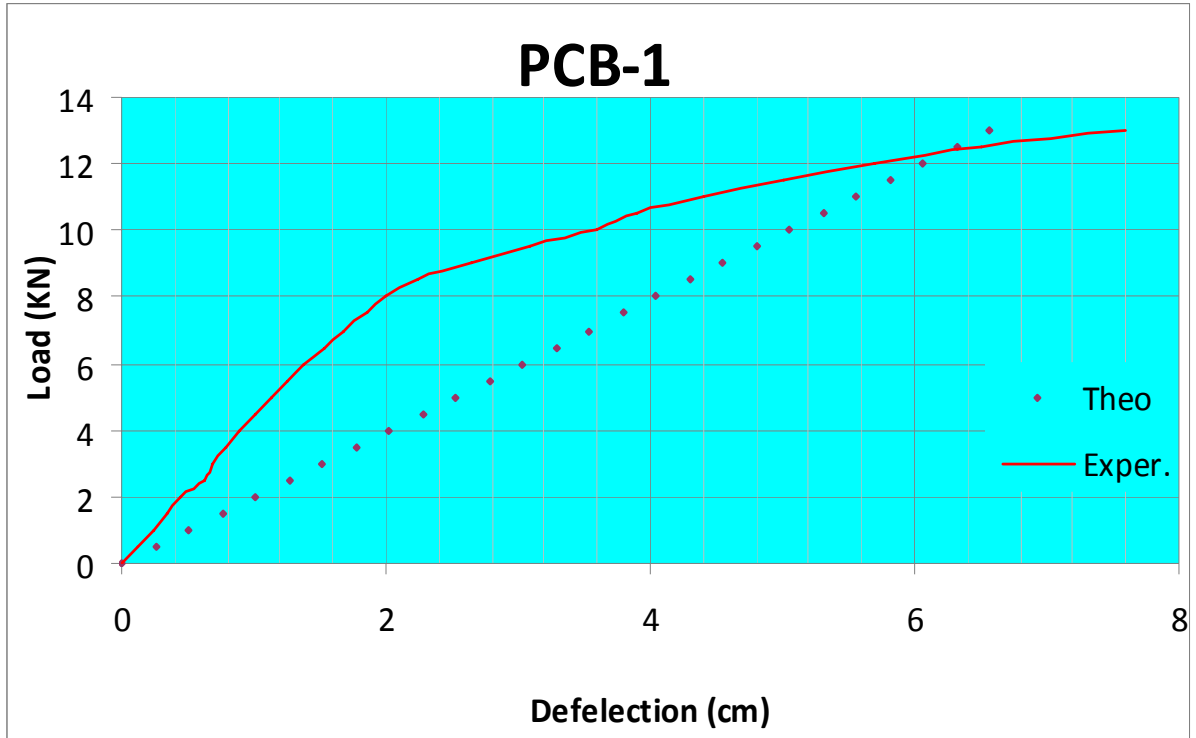

Fig 2.17 Experimental and Theoretical Load-Deflect(PCB-1)

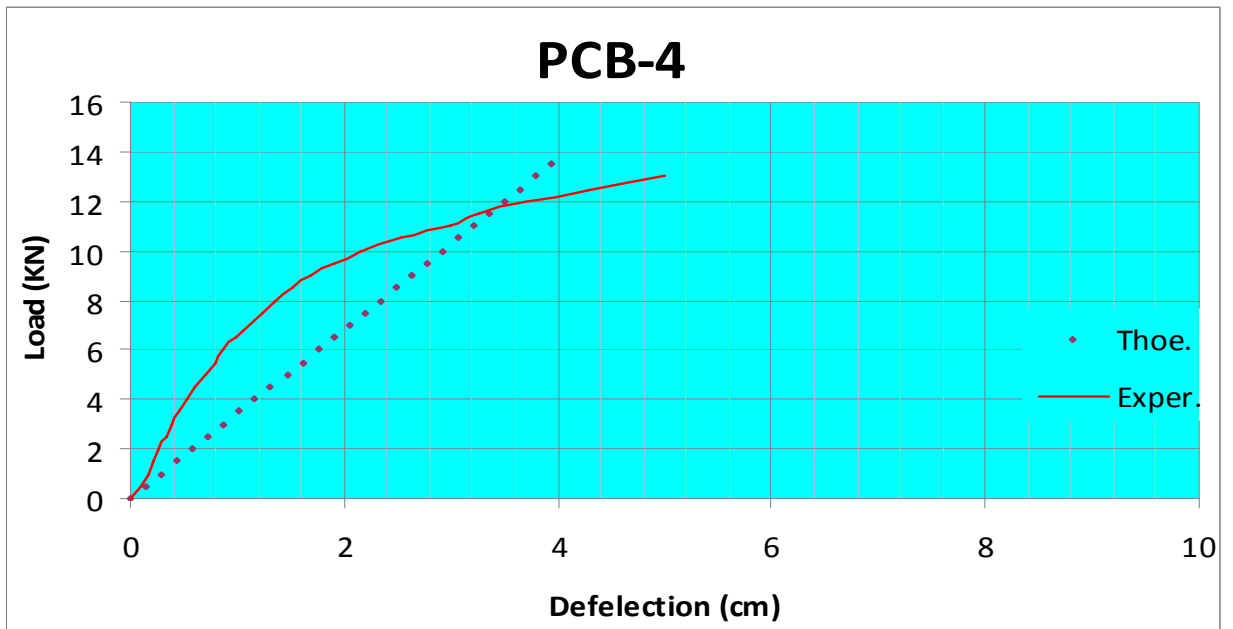

Fig 2.18 Experimental and Theoretical Load-Deflect(PCB-4)

4.0 REFERENCES

1. Abebe Dinku (Dr.Ing), Adil Zekaria (Dr. Ing), Asnake Adamu(Dr),Girma Zereyohanes(Dr.Ing),Final Reaserch Report on Pre-cast Beam-Slab System.
2. Admasu shimiles, “Precast Beam Elements for construction of reinforced concrete slabs”, Masters Thesis, June 2002.
3. EBCS-1, Basis of Deign and actions and structures, Minstry of Works and Urban Development, Addis Ababa, 1995.
4. EBCS – 2: part1, Structural use of concrete, Minstry of Works and Urban Development, Addis Ababa, 1995.
5. G. Zerayohannes, EBCS- 2: part 2, Design aids for Reinforced concrete sections on the basis of EBCS-1: part I, Ministry of works and urban Development, Addis Ababa, 1997.
6. EBCS-3, Design of Steel Structure, Ministry of Works and Urban Development, Addis Ababa, 1995.
7. SAP 2000 Manual
8. A.H. Nilson, G. Winter, Design of concrete structures, Mc Graw- Hill, Inc., New York, Eleventh edition, 1999.
9. A.M.Neville, Properties of concrete, Longman Scientific and Technical series, Third edition, 1986.
10. James G. Mac Gregor, “reinforced concrete mechanics and Design” Prentice Hall, Upper saddler River, New Jersey, 4th edition 1997.
12. M. Abaynesh, Construction materials, Addis Ababa, 1986.
13. K.A. Holes, Experimental strength of materials, The English Universities Press LTD, London, First edition, 1962.
14. Neguse Tebedge, Statically indeterminate structural analysis, AAU Press, 1984.
15. Technical Manual for Low Cost Housing,GTZ&MH Engineering.
16. W.E. Gessesse, A. Mohammed, G. Debissa, A. Anbessie, EBCS- 14, Building construction output standards I n Ethiopia, Ministry of Works and Urban Development, Addis Ababa, Unpublished.

APPENDIX-A

SAMPLES ON LOADING FOR CRITICAL CONDITION

1. INITIAL CONDITION

a. Geometrical property

$$b, \text{width} = 0.12\text{m}$$

$$D = \text{depth of slab} = 0.28\text{m}$$

$$\text{span, } l = 4.81\text{m}$$

$$\text{effective depth, } d = 0.24\text{m}$$

$$\text{Center to center distance b/n ribs} = 0.60\text{m}$$

b. material property

$$\text{concrete, C-25 } f_{cd} = 11.33\text{N/mm}^2$$

$$\text{steel, S-400 } f_{yk} = 400\text{N/mm}^2$$

$$f_{yd} = 347.83\text{N/mm}^2$$

$$f_{tcd} = 1.00\text{N/mm}^2$$

LOADING: Case 1

(when only LL no fresh concrete)

$$\text{- precast beam : } 1.3 * 0.12 * 0.08 * 25 = 0.31\text{kN/m}$$

$$\text{- hollow concrete block : } 1.3 * 17 * 0.0511 = 1.29\text{kN/m}$$

$$g_k = 1.60\text{kN/m}$$

Live load (q_k)

$$\text{- load during erection (assumption): } 1.6 * 1 * 0.6 = 0.6$$

$$\text{depending on structure } q_k = 0.6\text{kN/m}$$

design load :

$$p_d = g_k + q_k = 2.20\text{kN/m}$$

LOADING: Case 2

(when min. LL& fresh concrete pored)

Dead load (g_k)

$$\text{- precast beam : } 1.3 * 0.12 * 0.08 * 25 = 0.31\text{kN/m}$$

$$\text{- hollow concrete block: } 1.3 * 17 * 0.0511 = 1.29\text{kN/m}$$

$$g_k = 1.60\text{kN/m}$$

Live load (q_k)

$$\text{- load during erection (assumption): } = 0.5 * 0.6 = 0.30\text{kN/m}$$

$$\text{- fresh concrete } = 1.3 * ((.6 * .28) - (.105 + .12 * .08)) * 25 = 1.82\text{kN/m}$$

$$q_k = 2.12\text{kN/m}$$

(Fresh concrete is considered as live load b/c of it's dynamic action during pouring)

design load :

$$p_d = g_k + q_k = 3.717\text{KN/m} \quad (\text{factored})$$

Case 2 governs

COST

ANALYSIS

SHEET-1

COST

ANALYSIS

SHEET-2

COST

ANALYSIS

SHEET-3

COST

ANALYSIS

SHEET-4

COST

ANALYSIS

SHEET-5

COST

ANALYSIS

SHEET-6

Declaration

I, the undersigned, declare that the thesis is my original work, has not been presented for a degree in any other University and that all sources of materials used for the thesis have been duly acknowledged.

Name MATHEAS KEBEDE

Signature _____

Place Faculty of Technology,
Addis Ababa University

Date of Submission June, 2009