



ADDIS ABABA UNIVERSITY  
FACULTY OF TECHNOLOGY  
SCHOOL OF GRADUATE STUDIES  
DEPARTMENT OF MECHANICAL ENGINEERING

***TECHNICAL ASSESSMENT OF HYDRAULIC  
SYSTEMS USED IN Mi-24 and Mi-35 HELICOPTERS***

*A THESIS SUBMITTED TO SCHOOL OF GRADUATE STUDIES OF  
ADDIS ABABA UNIVERSITY IN PARTIAL FULFILLMENT FOR  
DEGREE OF MASTERS OF SCIENCE IN APPLIED MECHANICS  
(MECHANICAL ENGINEERING)*

*BY*  
ENDALKACHEW KEBEDE

*ADVISOR*  
Dr.-Ing. TAMRAT TESFAYE

March, 2008



ADDIS ABABA UNIVERSITY  
FACULTY OF TECHNOLOGY  
SCHOOL OF GRADUATE STUDIES  
DEPARTMENT OF MECHANICAL ENGINEERING

***TECHNICAL ASSESSMENT OF HYDRAULIC  
SYSTEMS USED IN Mi-24 and Mi-35 HELICOPTERS***

*A THESIS SUBMITTED TO SCHOOL OF GRADUATE STUDIES OF  
ADDIS ABABA UNIVERSITY IN PARTIAL FULFILLMENT FOR  
DEGREE OF MASTERS OF SCIENCE IN APPLIED MECHANICS  
(MECHANICAL ENGINEERING)*

*BY*  
ENDALKACHEW KEBEDE

*ADVISOR*  
Dr.-Ing. TAMRAT TESFAYE

March, 2008

## ACKNOWLEDGMENT

During the course of my thesis work, there were many people who were instrumental and morally helping me. Without their guidance, help and patience, I would have never been able to accomplish the work of this thesis. I would like to take this opportunity to acknowledge some of them.

I would like to express my gratitude to my thesis advisor Dr.- Ing. Tamrat Tesfaye, for exposing me to such kind of explorative and investigative thesis work. His encouragement, excellent guidance, creative suggestions and critical comments have greatly contributed to this thesis work. By letting me to work on such interesting topic of my choice, he enabled me to broaden my thought through reading lots of available materials. I believe that what I have learnt during the last two-year M.Sc study period will have an infinite profit for further analysis of this broad thesis in my future life.

Special thanks go out to Master Wolde Tsigu, who is the flight technician of Mi-helicopters in Ethiopian airforce, without his help and encouragement I would not have proceeded to complete this thesis work. He provided me different manuals and suggestion from his past experience. I would also like to thank all the Dejen Aviation Maintenance and Engineering Complex hydraulic shop technicians for their special cooperation and continual support they provided at all levels of the hydraulic assessment.

Finally, I must give immense thanks to my brother Ermias Kebede, my sister Haregewoin Kebede, and my friend Kidst Seyoum for their encouragement, continual support and love at all time in my life.

**Endalkachew Kebede**

**March, 2008**

**Addis Ababa**

## TABLE OF CONTENTS

|  |     |
|--|-----|
| ACKNOWLEDGMENT .....   | i   |
| TABLE OF CONTENT .....   | ii  |
| LIST OF FIGURES .....  | vii |
| ABSTRACT .....   | ix  |
| <b>CHAPTER ONE: Introduction</b> .....                                   | 1   |
| 1.1 Background .....   | 1   |
| 1.2 Objective of the study .....   | 2   |
| 1.3 Scope and Limitation .....   | 2   |
| 1.4 Organization of the thesis .....                                     | 3   |
| <b>CHAPTER TWO: General theory of helicopters</b> .....                  | 4   |
| 2.1 Introduction .....   | 4   |
| 2.2 Helicopter configuration .....                                       | 4   |
| 2.3 Helicopter operation .....   | 5   |
| 2.4 History of helicopters .....   | 7   |
| 2.5 Helicopter development .....   | 7   |
| 2.6 Development of Mi-helicopters .....                                  | 8   |
| 2.7 Some specifications on Mi-24 and Mi-35 helicopters .....             | 9   |
| <b>CHAPTER THREE: Aircraft hydraulic system theory</b> .....             | 11  |
| 3.1 Introduction .....   | 11  |
| 3.2 Purpose of hydraulic system in aircrafts .....                       | 11  |
| 3.3 Advantages of hydraulic system over other systems for aircraft ..... | 12  |

|  |           |
|--|-----------|
| 3.4 Hydraulic Fluid used in aircrafts . . . . .                                      | 13        |
| 3.5 Pascal’s theory and Bernoulli’s effect . . . . .                                 | 16        |
| 3.6 Flow conditions . . . . .  | 18        |
| 3.7 Aircraft hydraulic system main components . . . . .                              | 19        |
| 3.7.1 Hydraulic actuators . . . . .  | 19        |
| 3.7.2 Hydraulic system accumulators . . . . .  | 20        |
| 3.7.3 Distribution devices and reducers . . . . .                                    | 21        |
| 3.7.4 Pressure boosters and de-boosters . . . . .                                    | 22        |
| 3.8 Basic operations in hydraulic controls . . . . .                                 | 23        |
| 3.8.1 Pressure control (Pressure Limiting devices/relief valves) . . . . .           | 23        |
| 3.8.2 Flow control . . . . .   | 24        |
| 3.8.3 Flow restrictors . . . . .   | 26        |
| 3.8.4 Pressure regulation in hydraulic systems. . . . .                              | 28        |
| 3.9 Principles of hydraulic circuits . . . . .                                       | 29        |
| 3.9.1 Synchronizing circuits . . . . .   | 29        |
| 3.9.2 Sequencing circuits. . . . .   | 30        |
| 3.10 Hydraulic system circuit category. . . . .                                      | 31        |
| 3.10.1 Hydraulic system supply circuit . . . . .                                     | 31        |
| 3.10.2 Hydraulic system consumer circuit . . . . .                                   | 33        |
| <b>CHAPTER FOUR: Existing Mi-24 and Mi-35 helicopters hydraulic system . . . . .</b> | <b>35</b> |
| 4.1 General system category . . . . .  | 35        |
| 4.1.1 Main and auxiliary sub-systems . . . . .                                       | 35        |

|  |           |
|--|-----------|
| 4.1.2 Utility hydraulic sub-system . . . . .   | 35        |
| 4.2 Hydraulic system units and components in Mi-24 and Mi-35. . . . .                      | 44        |
| 4.2.1 АГC-60A hydraulic unit . . . . .   | 44        |
| 4.2.2 БГ-13-1 hydraulic unit . . . . .   | 46        |
| 4.2.3 KAY-110/115 booster . . . . .  | 48        |
| 4.2.4 HP92A-4 Plunger Pump . . . . .   | 48        |
| 4.2.5 ГA142/2 Three-position Solenoid operated valve . . . . .                             | 49        |
| 4.2.6 ГA165 Two-position Solenoid operated valve . . . . .                                 | 49        |
| 4.2.7 ГA165 Solenoid operated valves . . . . .   | 50        |
| 4.3 Basic steps in operation of hydraulic system in the helicopters . . . . .              | 50        |
| 4.3.1 Main and auxiliary hydraulic system operation principle . . . . .                    | 50        |
| 4.3.2 Utility hydraulic system operation principles . . . . .                              | 52        |
| 4.3.3 LG extension and retraction operation principles using utility sub-system . . . . .  | 53        |
| 4.3.4 Operation principles for emergency extension of LG using main hydraulic system . . . | 54        |
| <b>CHAPTER FIVE: Problem Identification . . . . .</b>                                      | <b>56</b> |
| 5.1 Requirement specification of the problem . . . . .                                     | 56        |
| 5.2 Background of the problem . . . . .  | 56        |
| 5.3 Category of hydraulic failure the may occur . . . . .                                  | 57        |
| 5.4 Causes for the specified Mi-helicopters hydraulic system failure . . . . .             | 59        |
| 5.4.1 Damage of fluid flow lines . . . . .   | 59        |
| 5.4.2 Electrical and mechanical systems failure . . . . .                                  | 61        |

|   |           |
|---|-----------|
| 5.4.3 Schedule on maintenance . . . . .   | 62        |
| 5.4.4 Pilot or technician’s skill and experience . . . . .  | 62        |
| 5.4.5 Hydraulic fluid contamination . . . . .   | 63        |
| 5.4.6 Environmental and altitude effects . . . . .  | 63        |
| 5.4.7 Effect of safety circuit system in case of other sub-systems failure . . . . .                              | 64        |
| 5.4.8 Lack of sufficient safety circuit (Alternative standby system) . . . . .                                    | 64        |
| <b>CHAPTER SIX: Solution Proposal and Evaluation of Concept Variants . . . . .</b>                                | <b>66</b> |
| 6.1 Introduction . . . . .  | 66        |
| 6.2 Avoiding hydraulic fluid contamination . . . . .  | 66        |
| 6.3 Solutions Proposed to upgrade the overall hydraulic circuit . . . . .   | 68        |
| 6.3.1 Solution Proposed to avoid complete drain of fluid from the tanks . . . . .                                 | 68        |
| 6.3.2 Solution proposed to get a stand by system for directional control damper and<br>guiding device . . . . .   | 71        |
| 6.3.3 Different solutions proposed to avoid the effect of failure on landing gear emer-<br>gency system . . . . . | 73        |
| 6.4 Evaluating the concept variants against different criteria for LG emergency system . . . . .                  | 74        |
| 6.4.1 Clarification of the concept variants for concept scoring decision . . . . .                                | 75        |
| 6.4.2 Concept scoring . . . . .   | 79        |
| 6.5 Concept review and technical detail of the selected solution . . . . .  | 81        |
| 6.5.1 Concept review on selected solution . . . . .   | 81        |
| 6.5.2 Technical detail of the new installed components . . . . .  | 82        |
| 6.6 Technical analysis on the upgraded overall hydraulic circuit . . . . .  | 84        |

|   |    |
|---|----|
| <b>CHAPTER SEVEN Conclusion and Recommendations</b> ..... | 87 |
| 7.1 Conclusion .....                                      | 87 |
| 7.2 Recommendation for further analysis .....             | 88 |
| REFERENCES .....  | 89 |

## LIST OF FIGURES

|  | <b>Page</b> |
|--|-------------|
| <i>Fig 3.1 Bernoulli's effect on a wing span</i> . . . . .   | 17          |
| <i>Fig 3.2 Turbulent Vs Laminar flow in a pipe</i> . . . . .   | 18          |
| <i>Fig 3.3 Pressure booster's operation</i> . . . . .  | 22          |
| <i>Fig 3.4 Pressure de-booster's operation</i> . . . . .   | 23          |
| <i>Fig 3.5 Pressure limiting device operating principle</i> . . . . .  | 24          |
| <i>Fig 3.6 Rotary type selector valve</i> . . . . .  | 25          |
| <i>Fig 3.7 Piston type selector valves operating principle</i> . . . . .   | 25          |
| <i>Fig 3.8 Stacked poppet type selector valves operating principle</i> . . . . .   | 26          |
| <i>Fig 3.9(a) One way fixed restrictor</i> . . . . .   | 27          |
| <i>Fig 3.9(b) Two way fixed restrictor</i> . . . . .   | 27          |
| <i>Fig 3.9(c) One way adjustable restrictor</i> . . . . .  | 27          |
| <i>Fig 3.9(d) Two way adjustable restrictor</i> . . . . .  | 28          |
| <i>Fig.3.10 Douglass pressure regulator</i> . . . . .  | 28          |
| <i>Fig.3.11 Synchronized circuit diagram</i> . . . . .   | 29          |
| <i>Fig.3.12 Hydraulic circuit sequence diagram</i> . . . . .   | 30          |
| <i>Fig.3.13 Sequencing valve operation diagram</i> . . . . .   | 30          |
| <i>Fig. 3.14 Schematic diagram of supply circuit with constant displacement pump and<br/>automatic relief unit</i> . . . . . | 32          |

|  |           |
|--|-----------|
| <i>Fig 4.1(a) Overall hydraulic system block diagram for Mi-24 helicopters . . . . .</i>                   | <i>36</i> |
| <i>Fig 4.1(b) Overall hydraulic system block diagram for Mi-35 helicopters . . . . .</i>                   | <i>38</i> |
| <i>Fig 4.2 Arrangement of hydraulic units in the helicopter configuration . . . . .</i>                    | <i>43</i> |
| <i>Fig 4.3 Main and auxiliary hydraulic sub-systems distribution block diagram. . . . .</i>                | <i>45</i> |
| <i>Fig 4.4 Utility sub-system hydraulic distribution block diagram . . . . .</i>                           | <i>47</i> |
| <i>Fig.6.1(a) Ground hydraulic power circuit line of Mi-24 helicopter . . . . .</i>                        | <i>69</i> |
| <i>Fig.6.1(b) Ground hydraulic power circuit line of Mi-35 helicopter . . . . .</i>                        | <i>69</i> |
| <i>Fig.6.1(c) The new modified ground power circuit line of both helicopters . . . . .</i>                 | <i>70</i> |
| <i>Fig.6.2(a) The present existing directional control damper circuit of both helicopters. . . . .</i>     | <i>71</i> |
| <i>Fig.6.2(b) The new modified directional control damper circuit . . . . .</i>                            | <i>72</i> |
| <i>Fig.6.3(a) Existing circuit for operation of guiding device . . . . .</i>                               | <i>72</i> |
| <i>Fig.6.3(b) The new modified circuit for operation of guiding device . . . . .</i>                       | <i>73</i> |
| <i>Fig.6.4 Options for showing direct connection of auxiliary line to LG emergency release . . . . .</i>   | <i>75</i> |
| <i>Fig.6.5 Options showing installation of manual LG emergency lever on auxiliary line . . . . .</i>       | <i>76</i> |
| <i>Fig.6.6 Connection of both the auxiliary and utility lines for input to manual lever . . . . .</i>      | <i>76</i> |
| <i>Fig.6.7 Options showing upgrading the main hydraulic sub-system . . . . .</i>                           | <i>77</i> |
| <i>Fig.6.8(a, b) Present LG emergency extension distribution line in the existing helicopters. . . . .</i> | <i>81</i> |
| <i>Fig.6.8(c) Modified LG emergency distribution line for both helicopters . . . . .</i>                   | <i>82</i> |
| <i>Fig.6.9 Landing gear emergency extension manual valve . . . . .</i>                                     | <i>83</i> |
| <i>Fig.6.10 Internal flow diagram of shuttle valve(61b) . . . . .</i>                                      | <i>83</i> |
| <i>Fig 6.11(a) The new modified overall hydraulic system block diagram for Mi-24 helicopter . . . . .</i>  | <i>85</i> |
| <i>Fig 6.11(b) The new modified overall hydraulic system block diagram for Mi-35 helicopter . . . . .</i>  | <i>87</i> |

## **ABSTRACT**

Helicopter is known as a rotating wing aircraft that consists of different subsystems in it. These subsystems are very closely interlinked to each other that make the helicopters a typical example of mechatronic system. One of these subsystems is a hydraulic subsystem, which is usually used for actuating landing gears, flight control boosters, weapon system and other purposes. Thus, hydraulic system can be the main core of helicopter movement that needs a special consideration to assess.

Currently, almost all Mi-24 helicopters in Ethiopian airforce are grounded or inoperative because of hydraulic related problems. The main problems include lack of reliable safety system for landing gear emergency extension, guidance device operation and directional control damper pressure loss. There are also other problems that led these helicopters to crash as shown from some safety records. Because of such problems, these helicopters couldn't function their expected mission. Whereas Mi-35 helicopters are in a better performance of flight evenif some improvements and modifications are still required. Moreover this, difficulty of life-saving by parachute from the helicopter in flight lowers the confidence of pilots and flight technicians.

This thesis work is mainly focused on how this problem or loss can be avoided by identifying the problems and proposing the possible solutions and remedies to be taken. Based on the two specified helicopters, a case study has been implemented from the available documents and past experience. And finally, different solutions are proposed and selected to upgrade the existing hydraulic system of both Mi-24 and Mi-35 helicopters.

# Chapter One

---

## INTRODUCTION

### 1.1 Background

Helicopters are known as rotary-wing aircrafts, as opposed to fixed-wing aircraft such as airplanes. The helicopter's ability to maneuver in and out of hard-to-reach areas and to hover efficiently for long periods of time makes it valuable for operating in places where airplanes cannot land. These helicopters can perform important military tasks such as ferrying troops directly into combat areas or quickly transporting wounded soldiers to hospitals. The helicopter can not fly as fast as the airplanes and has a poor cruising performance, but it is the obvious choice for tasks where vertical flight is necessary.

In case of an airplane, the wings create lift and the engine produces thrust. While a helicopter produces thrust by means of the blades of a main rotor as it rotates above the fuselage of the aircraft. As the blades rotate, airflow is created over the surface, resulting in lift, which raises the helicopter upward. The same rotor blades can be controlled to make the helicopter travel forward, backward, or sideways. Because of this; rotating wing aircrafts or helicopters have the capability of sustaining lift and control after a loss of power by autorotation process. This process of sustaining the lift and control after power loss becomes effective if the pre-condition in the hydraulic safety system works.

Safe operation after loss of power is required of any successful aircraft. As experience shows that next to engine failure, hydraulic failure is probably the most serious problem a pilot can encounter in a rotary wing aircrafts<sup>[1]</sup>. Hydraulic failure in a flying helicopter means a loss of flight control function. This is because of hydraulic effect on most of the helicopter mechanisms including the lift and thrust. Because of the load and its wide application; the requirement for hydraulic power is so critical on rotor wing aircraft that a great attention has become a significant engineering concern. And yet while it is clear that hydraulic systems are a major concern to the pilot, very few pilots know much about how the system works<sup>[1]</sup>.

Hydraulic circuit in the existing Mi-24 and Mi-35 helicopters consist of electro-mechanical sub-systems working together to meet the required purpose. Due to such interdependencies, failure on either of the sub-system affects the other. To avoid such conditions there has to be a reliable and efficient hydraulic system circuit to get a confidence in flight of these helicopters. Nowadays, the existing Mi-24 helicopters in Ethiopian Airforce are almost grounded due to the main reason related to its hydraulic system safety condition. But, most of Mi-35 helicopters are in flight operation due to their improved and upgraded performance in the hydraulic circuit.

## 1.2 Objective of the Study

The main objective of this thesis is concentrated on **assessment of the observed drawbacks in the existing hydraulic system of Mi-24 & Mi-35 helicopters so as to protect from failure**. And the specific objectives in this study are used:

- to identify the existing problems of the specified helicopters
- to create awareness on the problems during maintenance
- to look for different alternative solutions to the problems
- to select for appropriate solutions
- to suggest and provide data for further study, overall performance analysis and upgrade of the specified helicopters in the Ethiopian Airforce.

## 1.3 Scope and Limitation

The scope of this thesis work is to focus on the present hydraulic system of Mi-24 and Mi-35 helicopters so that overall performance of these helicopters in Ethiopian Airforce can be under control. Furthermore, giving a comment on the existing helicopters has a positive impact for further development of the thesis work in that area. Therefore, in the study, in addition to the main problems, some important factors affecting the system are also considered.

Because of limitations on the availability of resources from the manufacturer, this proposed assessment will only serve as a starting point for those who try to implement it. Thus, it requires a permission from the manufacturer so as to get sufficient data for

regular updating and further analysis based upon the current performance of the specified helicopters. Moreover; getting a proper and detail documented report about the crashed helicopters because of hydraulic failure, and lack of time and manpower due to its complexity was another limitation occurred during this paper work.

### **1.4 Organization of the Thesis**

The thesis is organized in seven chapters. Chapter one begins with background, objective, limitations and organization of the thesis. Chapter two discusses about general theory and specification of helicopters. Chapter three discusses about general theory of aircraft hydraulic system, and this chapter gives theoretical background for the thesis work. It also includes analysis of different hydraulic circuits and components. The fourth chapter concentrates on technical analysis of the existing Mi-24 and Mi-35 helicopters hydraulic system. This chapter gives a detail information about what the hydraulic system inside the specified helicopters look like and how it works.

Problem identification is the fifth chapter in which major problems and causes in hydraulic circuit of the specified helicopters are identified. Then, identified problems are categorized into groups, and main causes for the hydraulic failure of each helicopter are also specified in this chapter. The sixth chapter deals about proposed solutions to avoid the risk due to hydraulic failure. Different solutions are collected and evaluated to select the best method for upgrading the circuits. Also some corrections and comments for improvement are discussed, and an attempt is made on analysis of the selected solutions. This improvement is based on the selected solution in this chapter. Finally; existing hydraulic circuits have been modified to improve performance of the specified helicopters in case of emergency landing. Conclusion and recommendations have been presented in the last chapter.

## Chapter Two

---

### 2. GENERAL THEORY OF HELICOPTERS

#### 2.1 Introduction

Helicopter is an aircraft that uses rotating wings to provide lift, propulsion, and control. The rotor blades rotate about a vertical axis, describing a disk in a horizontal plane. Aerodynamic forces are generated by the relative motion of a wing surface with respect to the air. The helicopter with its rotary wings can generate these forces even when the velocity of the vehicle itself is zero, in contrast to fixed wing aircraft, which require a translational velocity to sustain flight. The helicopter therefore has the capability of vertical flight, including vertical take-off, landing and hovering.

The rotor must efficiently supply a thrust force to support the helicopter weight. Efficient vertical flight means a low power loading (ratio of rotor power required to rotor thrust), because the installed power and fuel consumption of the aircraft are proportional to the power required. Conservation of momentum requires that the rotor lift be obtained by accelerating air downward, because corresponding to the lift is an equal and opposite reaction of the rotating wings against the air.

Since the helicopter must also be capable of translational flight, a means is required to produce a propulsive force to oppose the aircraft and rotor drag in forward flight. This propulsive force is obtained from the rotor, by tilting the thrust vector forward. The rotor is also the source of the forces and moments on the aircraft that control its position, attitude and velocity. In a fixed wing aircraft; the lift, propulsion and control forces are provided by largely separate aerodynamic surfaces. In the helicopter; all the three forces are provided by the rotor which in-turn controlled by different systems together.

#### 2.2 Helicopter Configuration

The arrangement of the rotor or rotors on a helicopter is perhaps its most distinctive external feature and is an important factor in its behavior, notably its stability and control characteristics. Usually the power is delivered to the rotor through the shaft, accompanied by a torque. The aircraft in steady flight can have no net force or moment acting on it,

and therefore the torque reaction of the rotor on the helicopter must be balanced in some manner. The method chosen to accomplish this torque balance is the primary determinant of the helicopter configuration. Two methods are in general use; a configuration with a single main rotor and a tail rotor, and configurations with twin contra-rotating rotors.

The single main rotor and tail rotor configuration uses a small auxiliary rotor to provide the torque balance (and yaw control). This rotor is on the tail boom, typically slightly beyond the edge of the main rotor disk. The tail rotor is normally vertical, with its shaft horizontal and parallel to the helicopter lateral axis. The torque balance is produced by the tail rotor thrust acting on an arm about the main rotor shaft. The main rotor provides lift, propulsive force, and roll, pitch, and vertical control for this configuration.

A twin main rotor configuration uses two contra-rotating rotors, of equal size and loading, so that the torques of the rotors are equal and opposing. There is then no net yaw moment on the helicopter due to the main rotors. This configuration automatically balances the main rotor torque without requiring a power-absorbing auxiliary rotor.

## 2.3 Helicopter Operation

Operation in vertical flight, with no translational velocity, is the particular role for which the helicopter is designed. Operation with no velocity at all relative to the air, either vertical or translational, is called hover. Lift and control in hovering flight are maintained by rotation of the wings to provide aerodynamic forces on the rotor blades. General vertical flight involves climb or descent with the rotor horizontal, and hence with purely axial flow through the rotor disk. A useful aircraft must be capable of translational flight as well. The helicopter accomplishes forward flight by keeping the rotor nearly horizontal. The rotor continues to provide lift and control for the aircraft. It also provides the propulsive force to sustain forward flight, by means of a small forward tilt of the rotor thrust.

Safe operation after loss of power is required of any successful aircraft. The fixed wing aircraft can maintain lift and control in power-off flight, descending in a glide at a shallow angle. Rotating wing aircraft also have the capability of sustaining lift and

control after a loss of power. Power-off descent of the helicopter is called *autorotation*. The rotor continues to turn and provide lift and control. The power required by the rotor is taken from the air flow provided by the aircraft descent. The procedure upon recognition of loss of power is to set the controls as required for autorotative descent, and establish equilibrium flight at the minimum descent rate. Then near the ground the helicopter is flared, using the rotor-stored kinetic energy of rotation to eliminate the vertical and translational velocity just before touchdown. The helicopter rotor in vertical power-off descent has been found to be nearly as effective as a parachute of the same diameter as the rotor disk; about half that descent rate is achievable in forward flight.

A rotary wing aircraft called the autogiro uses autorotation as the normal working state of the rotor. In the helicopter, power is supplied directly to the rotor, and the rotor provides propulsive force as well as lift. In the autogiro, no power or shaft torque is supplied to the rotor. The power and propulsive force required to sustain level forward flight are supplied by a propeller or other propulsion device. Hence the autogiro is like a fixed wing aircraft, since the rotor takes the role of the wing in providing only lift for the vehicle, not propulsion. Sometimes the aircraft control forces and moments are supplied by fixed aerodynamic surfaces in the airplane, but it is better to obtain the control from the rotor using hydraulic system controllers. The rotor performs much like a wing, and has a fairly good lift-to-drag ratio. Although rotor performance is not as good as that of a fixed wing, the rotor is capable of providing lift and control at much lower speeds. Hence the autogiro is capable of flight speeds much slower than fixed-wing aircraft. Without power to the rotor itself, however, it is not capable of actual hover or vertical flight. Because autogiro performance is not that much better than the performance of an airplane with a low wing loading, it has usually been found that the requirement of actual VTOL capability is necessary to justify the purpose of a rotor on an aircraft.

## 2.4 History of Helicopters

The word 'helicopter' is adapted from the French hélicoptère, coined by Gustave de Ponton d'Amecourt in 1861. It is linked to the Greek words “helik” (spiral or turning) and “pteron” (wing). The initial development of rotating-wing aircraft faced three major

problems that had to be overcome to achieve a successful vehicle. The first problem was to understand and develop means of controlling the helicopter, including balancing the rotor torque. The second problem was to find a light and reliable engine. The reciprocating internal combustion engine was the first to fulfill the requirements, and much later the adoption of the turbo-shaft engine for the helicopter was a significant advance. The final problem was to develop a light and strong structure for the rotor, hub, and blades while maintaining good aerodynamic efficiency. These problems were essentially the same as those that faced the development of the airplane and were solved eventually by the Wright brothers. The development of the helicopters in many ways paralleled that of the airplane. That helicopter development took longer may be attributed to the cost of vertical flight, which required a higher development of aeronautical technology before the problems could be satisfactorily overcome.

## 2.5 Helicopter Development

Inventors and engineers perfected the design of the helicopter gradually, over many years. A history of helicopter development is usually begun with mention of the Chinese top and Leonardo da Vinci. The Chinese flying top (c.400B.C) was a stick with feathers mounted on top, which was spun by the hands and released to propel like the blades of a modern propeller. Among da Vinci's work (late 15<sup>th</sup> century) were sketches of a machine for vertical flight utilizing a screw type propeller. In the 18<sup>th</sup> century there was some work with models that had little impact on helicopter development.

Around 1900 the internal combustion reciprocating gasoline engines became available. It made possible airplane flight and eventually helicopter flight as well. Also the development of better engines during and after World War I solved the problem of an adequate power source, at least enough to allow experimenters to face the task of finding a satisfactory solution for helicopter control.

An important development was the application of turbo-shaft engine to helicopters, replacing the reciprocating engine. A substantial performance improvement was realized because of the lower specific weight of the turbo-shaft engine.

The invention of the helicopter may be considered complete by the early 1950's, and so we conclude this history at that point. In years that followed, several helicopter designs achieved extremely successful production records, and some very large helicopters were constructed. The operational use of the helicopter has grown to a major factor in the air transportation system. Helicopter engineering is thus now involved more with research and with development than with invention.

## 2.6 Development of Mi-Helicopters

The **Mi** helicopters are designed by Mikhail Leontyevich Mil that is why they are called as Mi helicopters. And the plant that manufactures those helicopters is a Mil helicopter plant. While a student Mil was interested in rotary-wing airborne vehicles. And during his industrial practice in summer of 1929 he took part in building the first Russian autogyro. By early 40s, Mikhail Mil became one of the leading home experts in autogyro and helicopter theory.

After successfully completing the tests of the first light GM-1 (Mi-1) helicopter, the design bureau was granted new convenient premises. State support to the experimental helicopter plant increased considerably after the plant had received the order for building Mi-4 multipurpose helicopter, and Mi-6 heavy transport. By early 60s the creation of Mi-4 multi-purpose helicopter and then the creation of Mi-6 and Mi-10 helicopters strengthened the reputation of plant and its manager in national aviation industry. It was possible to build small Mi-2 helicopter but larger prototypes of the Mi-8 had to be built, in compliance with the agreements and afterwards new Mi helicopter designs appeared such as Mi-17, Mi-18, Mi-24, Mi-26, Mi-35, and other versions.

## 2.7 Some Specifications on Mi-24 and Mi-35 Helicopters

Both Mi-24 and Mi-35 helicopters are intended for air support of the ground force units by firing at enemy combat equipment (including armor material) and manpower,

heliborne assault party landing as well as for evacuation of the wounded person from a battlefield. These helicopters are designed to have a single main rotor and tail rotor configuration with retractable tricycle nose wheel type landing gear. The main rotor provides lift, propulsive force, roll, pitch, and vertical control for the helicopter configuration. The tail rotor is normally vertical, with its shaft horizontal and parallel to the helicopter lateral axis that uses a small auxiliary rotor to provide the torque balance (and yaw control). The torque balance is produced by the tail rotor thrust acting on an arm about the main rotor shaft.

The pilot and weapon operator are seated in tandem cockpits under individual canopies. The Mi-24's distinguishing feature is its cabin which can accommodate eight airlanding troopers. The helicopter is powered by two TV3-117VMA turboshaft engines with air intakes equipped with dustproof devices to protect the powerplant from erosive wear when operating from unprepared sites. The helicopter is furnished with an auxiliary power unit for autonomous operation. Since the beginning of the Mi-24's full-scale production (1970), the following modifications have been manufactured:

- Mi-24P, equipped with a 30mm built-in fixed gun mount
- Mi-24D (its export version Mi-25), equipped with the Falanga ATGM system and other electrical equipment modifications.
- Mi-35, export version of the hind E.
- Mi-35M that has a twin barrel 23-mm gun.
- Mi-35P: Export version of the hind F

To enhance the helicopter combat survivability, provision is made for:

- crew cockpit armoring
- porous fuel tank filler
- fuel tank self-sealing covers
- fire fighting equipment
- infrared suppression exhaust mixer boxes over engine exhaust ducts

Mi-35 helicopters have more or less similar features except some modifications made to minimize the power required to take off. Some of the similarities and differences between the two helicopters is described in table 2.1 as follows.

*Table 2.1 Some useful specifications of Mi-24 and Mi-35 helicopters (Source<sup>[2, 3, 4, 5 & 6]</sup>)*

| <b>Description</b>   | <b>Mi-24</b>                         | <b>Mi-35</b>   |
|--|--------------------------------------|--|
| Flight speed   | (0 – 350)km/hr                       | (0 – 350)km/hr   |
| Flight altitude  | up to 5000m                          | up to 5000m  |
| Take off power   | 2200 hp                              | 2100 hp  |
| Compressor   | Axial type                           | Axial type   |
| Minimum permissible main rotor speeds: <ul style="list-style-type: none"> <li>• In transient conditions of flight (during 30 sec)</li> <li>• In auto rotation with engine running (no time limitations)</li> <li>• At landing with ballooning (free fall)</li> <li>• At failure of one engine</li> </ul> | 88%<br><br>88%<br><br>75%<br><br>75% | 88%<br><br>88%<br><br>75%<br><br>80% (in very rare case) |
| Hydraulic pump   | Axial plunger type                   | Axial plunger type                                       |
| Hydraulic fuel used  | AMГ-100 fluid                        | AMГ-100 fluid  |

## Chapter Three

---

### AIRCRAFT HYDRAULIC SYSTEM THEORY

#### 3.1 Introduction

Hydraulic systems are not new to aviation. As aircraft became more sophisticated newer systems with hydraulic power were developed. Modern aircrafts include many different types of subsystems. These subsystems are very closely interlinked to each other that makes an aircraft a typical example of mechatronic system. One of these subsystems is a hydraulic subsystem, which is usually used for actuating most of the mechanical subsystems, such as landing gear, flight control surfaces, weapons system etc. Thus the hydraulic system is a very essential part of the aircraft, and its reliability and functionality are very essential to the flight worthiness of the whole aircraft.

Hydraulic systems take engine power and convert it to hydraulic power by means of a hydraulic pump. This power can be distributed throughout the airplane by means of tubing that runs through the aircraft. Hydraulic power may be reconverted to mechanical power by means of an actuating cylinder, or turbine. The hydraulic system used for generating the actuating force needed and actual flight controls are either mechanical or electronic. It is thus an inseparable link between aircraft control system and mechanical system to be actuated. Therefore, its both design and research can not completely be separated from other subsystems and the aircraft in whole, but the interactions must always be taken into account.

#### 3.2 Purpose of Hydraulic System in Aircrafts

Although some aircraft manufactures make greater use of hydraulic systems than others, the hydraulic system of average modern aircraft performs many functions. The purpose of this hydraulic system is to assist the operator in accomplishing a mechanical task that would otherwise be impractical or impossible because of the amount of work required. On some light aircraft, for instance, flaps are directly connected to a flap handle that the pilot pulls. The pressure felt by the pilot when deploying the flaps is the weight of the control surface combined with the air load on the surface, plus any constraints inherent

to the mechanism. On the ground, there is little resistance and the flaps are very light. In the air, the faster the aircraft is moving, the greater the strength required to extend the flaps. In a large or fast-moving aircraft, the air load can easily be too great for the pilot to physically deploy the flaps.

In systems that require very high force to be exerted with movement over short distances, the natural choice of mechanism is a hydraulic cylinder. Some of the principal features of hydraulic systems relevant to such applications are; high specific force, energy storage possibility, positive displacement, low velocity and transmission over short distance. To solve that problem, the necessary work is done by moving a fluid in such a manner that it gives the pilot mechanical advantages. Such a system is called *fluid power*. To get a maximum mechanical benefit, fluid power should be in a *closed system* to get more work that is accomplished with a fixed amount of fluid. Common examples of such systems include brakes, automotive and construction jacks, gas station lifts, and bearing presses. With limited exceptions, pneumatics are typically limited to aircraft pressurization and instrumentation usage.

Some devices operated by hydraulic systems in aircraft are:

- ◆ retraction and extension of landing gears
- ◆ primary control boosters
- ◆ sweep back and forth of wing flaps, and other flight control surfaces
- ◆ opening and closing of doors and hatchways
- ◆ auto-pilot and gun turrets
- ◆ shock absorption systems and valve lifter systems
- ◆ dive, landing, speed and flap brakes
- ◆ pitch changing mechanism, spoilers on flaps
- ◆ bomb bay doors and bomb displacement gears.

### 3.3 Advantages of Hydraulic System over Other Systems for Aircraft

(which is a forerunner for helicopter use)

- ◆ It is lighter in weight than alternate existing systems.

- ◆ It is dead beat, i.e. there is an absence of sloppiness in its response to demands placed on the system.
- ◆ It is reliable; either it works or doesn't.
- ◆ It can be easily maintained.
- ◆ It is not a shock hazard; it is not much of a fire hazard.
- ◆ It can develop practically unlimited force or torque.

For example: A gun turret must be able to change direction almost instantaneously. This is accomplished by this hydraulic system. In an electrical system, the rotating armature must come to full stop and then reverse direction or else the armature will burn out. This doesn't happen with a hydraulic system because there is no need for a motor in the hydraulic system. Also in a landing gear the hydraulic motor can produce enough power to pull up the landing gear system without trouble even though air loads act on the system and the slip stream air is impinging against it.

The actuating cylinder can change hydraulic power to linear or rotational motion. It has a reduction gear in it to reduce rotating motion to that amount which is needed. Previously, systems used to control motion by using steel cables connected by pulleys between the controlling mechanism (such as the pedals) and the controlled surface (such as the rudder). The cables were affected by expansion rates of the cables due to temperature changes. Hydraulic systems can control motion without worrying about the effect of temperature since it is a closed system (not open to the atmosphere) compared to a cable system. This means better control of the plane and less lag time between the pilot's movement to control the plane and the response by control surfaces.

### 3.4 Hydraulic Fluid used in Aircrafts

Fluid is often a misunderstood term; there are many forms of fluid. The word fluid often makes one think of water, which is probably the best-known fluid. (The word hydraulic is based upon the Greek word '*hydros*', which means water.) There are, however, numerous examples of fluids besides water. Any gas or liquid is a fluid, including air, nitrogen, gasoline and even a soft drink. Fluid power, therefore, takes one of two forms;

*pneumatics* that are made up of compressible gases and *hydraulics* that are incompressible liquids.

The primary purpose of hydraulic fluid is to transmit force from one place, through nonmoving hydraulic tubes, to another location. The advantage of using a liquid is its incompressibility. Except for minor friction losses as the fluid passes through the tubing, all applied force is transmitted throughout the system, according to Pascal. Thus, if a number of passages exist in a system, pressure can be distributed through all of them by means of the liquid.

Hydraulic fluids are different and generally speaking they cannot be mixed. Manufacturers of hydraulic devices usually specify the type of liquid best suited for use with their equipment, in view of the working conditions, the service required, temperatures expected inside and outside the systems, pressures the liquid must withstand, the possibilities of corrosion, and other conditions that must be considered.

If incompressibility and fluidity were the only qualities required, any liquid not too thick might be used in a hydraulic system. But a satisfactory liquid for a particular installation must possess a number of other properties. Some of the properties and characteristics that must be considered when selecting a satisfactory liquid for a particular system are discussed based upon four primary considerations:

- Viscosity
- Chemical stability
- Flash point
- Fire point

### **Viscosity**

One of the most important properties of any hydraulic fluid is its viscosity. Viscosity is internal resistance to flow. A liquid such as gasoline flows easily (has a low viscosity) while a liquid such as tar flows slowly (has a high viscosity). Viscosity increases with temperature decrease.

A satisfactory liquid for given hydraulic system must have enough body to give a good seal at pumps, valves, and pistons; but it must not be so thick that it offers resistance to

flow, leading to power loss and higher operating temperatures. These factors will add to the load and to excessive wear of parts. A fluid that is too thin will also lead to rapid wear of moving parts, or of parts which have heavy loads.

There are several types of *viscometers* that are used as an instrument to measure the viscosity of a hydraulic fluid used on aircraft systems. Such instruments measure the number of seconds it takes for a fixed quantity of liquid to flow through a small orifice of standard length and diameter at a specific temperature.

### **Chemical Stability**

Chemical stability is another property which is exceedingly important in selecting a hydraulic liquid. It is the liquid's ability to resist oxidation and deterioration for long periods. All liquids tend to undergo unfavorable chemical changes under severe operating conditions. This is the case, for example, when a system operates for a considerable period of time at high temperatures.

Excessive temperatures have a great effect on the life of a liquid. It should be noted that the temperature of the liquid in the reservoir of an operating hydraulic system does not always represent a true state of operating conditions. Localized hot spots occur on bearings, gear teeth, or at the point where liquid under pressure is forced through a small orifice. Continuous passage of a liquid through these points may produce local temperatures high enough to carbonize or sludge the liquid, yet the liquid in the reservoir may not indicate an excessively high temperature. Liquids with a high viscosity have a greater resistance to heat than light or low viscosity liquids which have been derived from the same source. The average hydraulic liquid has a low viscosity. Fortunately, there is a wide choice of liquids available for use within the viscosity range required of hydraulic liquids.

Liquids may break down if exposed to air, water, salt, or other impurities, especially if they are in constant motion or subject to heat. Some metals, such as zinc, lead, brass, and copper, have an undesirable chemical reaction on certain liquids.

These chemical processes result in the formation of sludge, gums, and carbon or other deposits which clog openings, cause valves and pistons to stick or leak, and give poor lubrication to moving parts. As soon as small amounts of sludge or other deposits are formed, the rate of formation generally increases more rapidly. As they are formed, certain changes in the physical and chemical properties of the liquid take place. The liquid usually becomes darker in color, higher in viscosity, and acids are formed.

### **Flash point**

Flash point is the temperature at which the fluid produces enough combustible vapor that it will ignite momentarily or flash when a flame is applied. A fluid with a high flash point can get very hot before it becomes susceptible to flashing. Looking at it from another perspective, a fluid with a high flash point has minimal evaporation under normal operating conditions; therefore, a high flash point is a desirable characteristic of hydraulic fluids.

### **Fire Point**

This is the next step up the temperature spectrum from flash point. A hydraulic fluid's fire point is the temperature at which a substance gives off vapor in sufficient quantity to ignite and continue to burn when exposed to a spark or flame. Like flash point, a high fire point is required for desirable hydraulic liquid's operating condition.

## **3.5 Pascal's Theory and Bernoulli's Effect**

As stated before, a hydraulic system transmits power by means of fluid flow under pressure. The rate of flow of oil through the system into the actuating cylinder will determine the speed with which the piston rod in the actuating cylinder extends or retracts. When the cylinder is installed on the aircraft, it is already filled with oil. This insures that no air bubbles are introduced into the hydraulic system, which can adversely affect the operation of the system.

### **Pascal's Theory**

The method by which fluid is used to create force was explained by Pascal. In a confined stationary liquid, neglecting the effect of gravity, pressure is distributed equally and undiminished in all directions; it acts perpendicular to the surface it touches. Because

the actuating cylinder is not vented, the force delivered through the piston to the surface of the fluid is translated into a pressure on the surface of the fluid.

The pressure ( $p$ ) acting on the incompressible oil does work  $[(\text{pressure}) \times (\text{Area of piston}) \times (\text{piston's stroke}) = \text{Work}]$ .

### **Bernoulli's Effect**

Daniel Bernoulli was the man who discovered GRAVITY and LIFT, and without him we wouldn't have airplanes. Bernoulli said that we live at the bottom of an ocean, but this ocean is not of water but of air. Air pressure is like the weight of the air, on earth the air pressure is strong enough to keep us from floating around but light enough so that we don't have much trouble walking. On some planets, we would be able to bounce up and down easily, and feel very light.

When air is going faster it has less air pressure than slow moving air. An airplane flies because, the air underneath is pushing upwards, this is *lift*. The air under the wing which is going slow, creates more pressure than the air going over the top, because the air at the top is going faster therefore creating less pressure pushing it down.

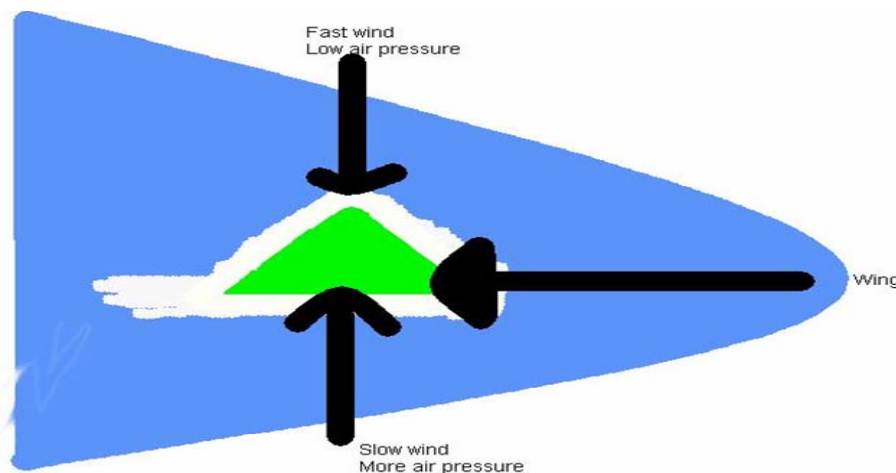

*Fig 3.1 Bernoulli's effect on a wing cross-section*

The proof of Bernoulli's principle is shown in the figure above to show how a lift is created on a wing of an aircraft moving in the air. Hence, the most basic fluid dynamics principle involved is Bernoulli's principle, which states that if the speed is high, the pressure is low, and vice versa.

### 3.6 Flow conditions

Flow conditions can be of several types. Flows may be steady (meaning not time varying) or unsteady (meaning that the flow is time varying). An example of unsteady flow is when actuation starts or stops, the flow becomes dependent upon the motion of the actuating piston. A steady flow example is when the piston has reached its operating speed in a very long pipe; the flow in the pipe will no longer vary as a function of time.



*Fig 3.2 Turbulent Vs Laminar flow in a pipe*

Flows may be one-dimensional where the flow parameters (for example: density, velocity, temperature, pressure) vary as a function of one spatial variable (for example,  $x$ ) and variations in the other two spatial dimensions (i.e.,  $y$  and  $z$ ) are negligible by comparison. Flows may be two-dimensional where the flow parameters vary as functions of  $x$  and  $y$ , for example, while variations in  $z$  are small and can be neglected. Flows may be three dimensional where the flow parameters depend upon all three spatial dimensions.

Flows may be incompressible, i.e., the flow density does not change with position or time. Flows may be compressible, such as in the case of a gas at high speeds. Also flows may be described as creep, laminar or turbulent. Creep flow occurs in highly viscous fluids at very low speeds (fluids that exhibit a high resistance to motion; for example, molasses). For flow speeds that are higher than in creep flow, whether the flow is laminar or turbulent depends upon the Reynolds number. Flows that start as laminar flows may transit to turbulent flows, (for example flows around spheres or over wings).

#### **Laminar Flow**

Laminar flows occur when fluid particles move along straight, parallel layers. These layers are called laminae, from which laminar flow gets its name. Laminar flows normally occur during steady state conditions. The velocity of each layer may be the same or may change slightly from layer to layer. The fluid particles of each layer do not mix with the fluid particles of other layers. In steady situations, the energy of the fluid is conserved.

### **Turbulent Flow**

Turbulent flow occurs when the particles of fluid move in all directions and fluid mixing occurs. This may occur when the flow becomes unsteady. Turbulent flows can also occur during steady conditions when there are small velocity and pressure variations compared to the mean (or average) flow velocity and pressure, but the mean flow velocity and pressure do not vary with time. Mean flow velocity and pressure represent the average velocity and pressure of all the fluid particles in the flow. In unsteady situations, the energy of the fluid is not conserved. Turbulent flow will cause a pressure drop, and this type of flow is sometimes called particle flow.

### **Causes for Transition**

Flows may transfer from laminar to turbulent due to the following reasons:

- ◆ Roughness on the inner surface of the pipe
- ◆ Abrupt changes in pipe directions – e.g., 90 degree bends
- ◆ Pipe size changes – a velocity increase in the fluid due to a decrease in cross-sectional area in the pipe that can cause the flow to change from laminar to turbulent.

The type of flow (whether laminar or turbulent) depends upon the Reynolds number,  $R_N$ ,

$$R_N = \frac{\rho v d}{\mu}$$

where,  $\rho$  represents the density  
 $V$  is velocity of the flow  
 $d$  is the hydraulic pipe diameter, and  
 $\mu$  represents the fluid viscosity.

## **3.7 Aircraft Hydraulic System Main Components**

### **3.7.1 Hydraulic Actuators**

Hydraulic actuators are devices for converting hydraulic pressure to mechanical motion (work). The most commonly utilized actuator is actuating cylinder; however, servo actuators and hydraulic motors are also employed for special applications where modified motion is required. *Actuating cylinders are used for direct and positive movement such as retracting and extending of landing gear, wing flaps, spoilers and slats.*

Design of actuating cylinders is determined by the functions that they are to perform. Actuating cylinders can be a single-acting or a double-acting cylinder types. In case of a single-acting cylinder, hydraulic pressure is applied to one side of the piston to provide force in one direction only. When hydraulic pressure is removed from the piston, a return spring moves the piston to its start position. Where as a double acting cylinder is designed so that hydraulic pressure can be applied to both sides of the piston. Thus, the cylinder can provide force in either direction. So, double acting cylinders are widely used for the operation of retractable landing gear, wing flaps, spoilers, bus doors and other similar applications.

Servo actuators are designed to provide hydraulic power to aid the pilot in the movement of various aircraft controls. Such actuators usually include an actuating cylinder, a multi-port flow control valve, check valves, and relief valves together with connecting linkages. Servo actuators are employed in situations where accurately controlled intermediate positions of units are required. The servo unit feeds back position information to the pilot's control, thus making it possible for the pilot to select any control position required. Such actuators are used to move large control surfaces such as aircraft rudder, elevator, and ailerons. For example, servo units are used to aid the pilot in the operation of collective pitch and throttle control lever in Mi-24/35 helicopter's friction clutch.

### 3.7.2 Hydraulic System Accumulators

#### **Purpose of Accumulators in the System:**

1. Absorbs the shock due to rapid pressure variations in a hydraulic system
2. Helps to maintain a constant pressure within the hydraulic system
3. Helps the hydraulic pump under peak pressure loads
4. It is an emergency source of power (the braking system has its own accumulator)

#### **Principle of Operation**

At the bottom of the accumulator is a gas valve. Compressed gas at about one half the system pressure is let into the accumulator through the gas valve. This forces the diaphragm that separates the oil side from the gas side to "pop" up towards the oil side.

Then oil is sent through the system. When the system pressure reaches a point when it is greater than the pressure of the accumulator, the diaphragm will deploy (inflate). Using Boyle's Law, the compressed gas will increase in pressure as its volume decreases. The diaphragm will move up or down, depending on system pressure.

When the diaphragm is at half way, the gas volume will be  $\frac{1}{2}$  as much as it was initially, while the accumulator pressure will be twice as much as its pre-load pressure (i.e.,  $\frac{1}{2}$  system pressure). Therefore when the accumulator is at half volume of gas, it will be charged at full system pressure.

### **Accumulator Shapes**

Accumulator can have different shapes according to its purpose. The shape can be; spherical or cylindrical or bottle type.

The spherical shape is the strongest and effective single shell body used to withstand high pressure before failing. The bottle type accumulator is not widely used on most aircrafts because of the effect on bladder used to expand and contract. Also the cylindrical type is not used very often because the friction will cause wearing of the body and piston, thereby allowing the gas pressure to escape.

### 3.7.3 Distribution Devices and Reducers

Distribution devices (valves) are the main part of hydraulic system to control a flow of fluid to the actuating mechanisms in aircraft control system. These hydraulic valves may be classified according to the following features:

- ▶ *Drive type*: manual or electrically (solenoid) controlled
- ▶ *Number of fixed positions of the wing*: two or three-position valves
- ▶ *Type of distribution device*: slide valve or plug type
- ▶ *Control method*: direct control or servo control method

Hydraulic reducers are intended to decrease the fluid pressure on separate portions of the system to the required value. They are necessitated owing to the fact that aircraft hydraulic systems use a number of actuating devices which are operable according to the

specifications on lower pressure than the working pressure in the supply line. The hydraulic reducers can be of a constant-pressure reducer which maintains a definite fluid pressure or variable-pressure reducers in which the pressure is set in the course of control.

### 3.7.4 Pressure Boosters, and De-boosters

#### Pressure Boosters

Pressure boosters are rarely used in aircraft (almost all planes use de-boosters). If we need higher pressure, we must change the entire power and actuating system. This adds weight that is not needed. In general, we cannot put-in larger pistons and piston cylinders to increase the power, because, normally we don't have the room for it. A simple solution is to raise the pressure in a localized area.

The function of a pressure booster is to act like a transformer; i.e, it raises the pressure of a small circuit connected to the power system. The booster is a cylinder made up of two pistons of different surface areas that are connected. The larger surface area ( $A_1$ ) is connected to the inlet side of the hydraulic system, and, the smaller surface area ( $A_2$ ) is connected to the outlet side of the hydraulic system as shown in the figure below.

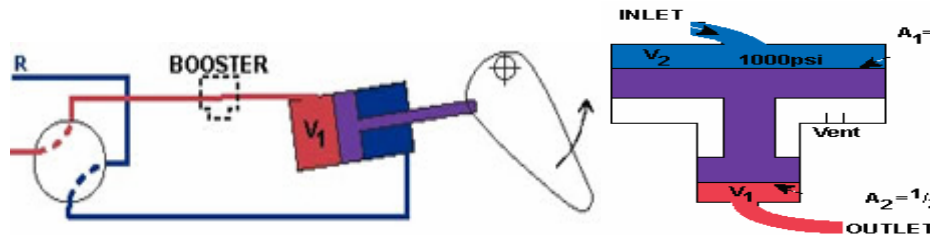

*Fig 3.3 Pressure booster's operation*

#### Disadvantages of a Pressure Booster

- ◆ Weight of the pressure booster is high if it is put into the aircraft, thereby reducing payload that the aircraft can carry.
- ◆ It requires a very large booster stroke to meet the requirement
- ◆ Pressure boosters must be built into the aircraft during the aircraft's construction, if high pressure is needed in the hydraulic system.
- ◆ Leakage from the pressure booster is an important factor and will increase possibility of fire hazards.

### Pressure De-Boosters

Pressure de-boosters are used to reduce the pressure in the system to a level that can be used by certain devices. Pressure de-boosters are pressure boosters turned upside down (that is, the inlet side of the booster has the smaller area piston and the outlet side has the larger area piston). They are employed in power brake systems, using engine power to help apply the brakes. Since aircraft wheels are made of magnesium, any high pressure on the wheels will cause them to split. That is why they must de-boost the pressure gotten from engine.

The inlet line to the de-booster comes from the power brake control valve. The outlet line goes to the brake system. This valve meters hydraulic fluid and hydraulic pressure directly. The force applied to the wheels to make them stop is proportional to how hard you push on the rudder pedal. It is normally used for a 1 or 2 cubic inch application.

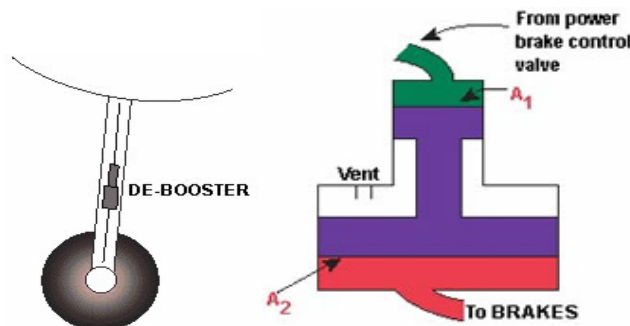

Fig 3.4 Pressure de-booster's operation

## 3.8 Basic Operations in Hydraulic Controls

### 3.8.1 Pressure Control (Pressure limiting devices/relief valves)

#### Function

Pressure limiting device or relief valves are required to limit the pressure in some section of the hydraulic system to a predetermined level. That pressure level may be considered dangerous and, therefore, must be limited in such a case.

#### Principle of Operation

The adjustment screw at the top of the pressure relief valve is set for a certain pressure value, let us call it  $P_2$ . In general, even with a pressure of  $P_1$ , the poppet would lift up, except that the spring is strong and has downward force forcing the poppet closed. Poppet

will not move until a pressure greater than that required is felt by the system (i.e.,  $P_1 > P_2$ ).

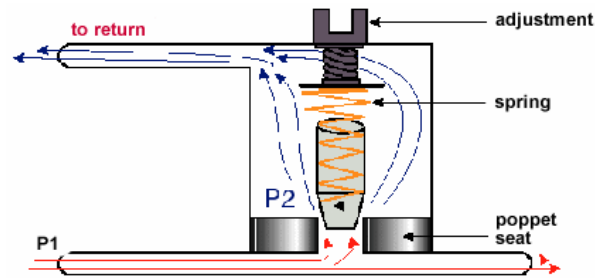

Fig 3.5 Pressure limiting device operating principle

When the pressure increases, the poppet will move up, forcing the excess liquid to move through opening at high velocity. On other side of seat, pressure is zero because the back side of the relief valve is connected to the return line. When the pressure in the system decreases below maximum, poppet will return to its seated position, sealing the orifice and allowing the fluid to follow its normal path. These type of pressure relief valves are only made to be used intermittently.

### 3.8.2 Flow Control

#### Selector Valves

Selector valves are used as (1) directional control devices to insure the movement of hydraulic fluid flow in the proper direction, and (2) as stop-locks to lock the selector switch in a certain position.

#### Types

There are three types of selector valves used in aircraft hydraulic system namely; rotary type, piston type and poppet type.

#### Rotary types

Rotary type selector valves are plugs within which are passage ways for the fluid to move through. Tubing from the hydraulic pump or return line are connected to the rest of the hydraulic system by movement of the plug. You cannot use high pressure oil because of leakage around the plug. To reduce leakage, you might want to make the plug fit more tightly into the selector valve body. However, the better you make the fit, the more friction will exist between the plug and the selector valve body, making it difficult to operate.

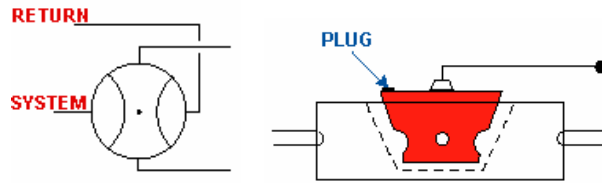

Fig 3.6 Rotary type selector valve

### Piston Type

Positions 1, 2 and 3 (shown in fig.--) are representative positions for the piston-type selector valve. Position (1) is the position of the selector valve, for example, upon the extension of landing gear or the lowering of flaps. Position (2) is the position of the selector valve upon retraction of the landing gear or the raising of the flaps. Position (3) is the stop-locking position of this type of valve. This piston type valve uses the Vickers spool mechanism in which the piston "lands" isolate the high pressure oil (red area) from the low pressure oil (blue area).

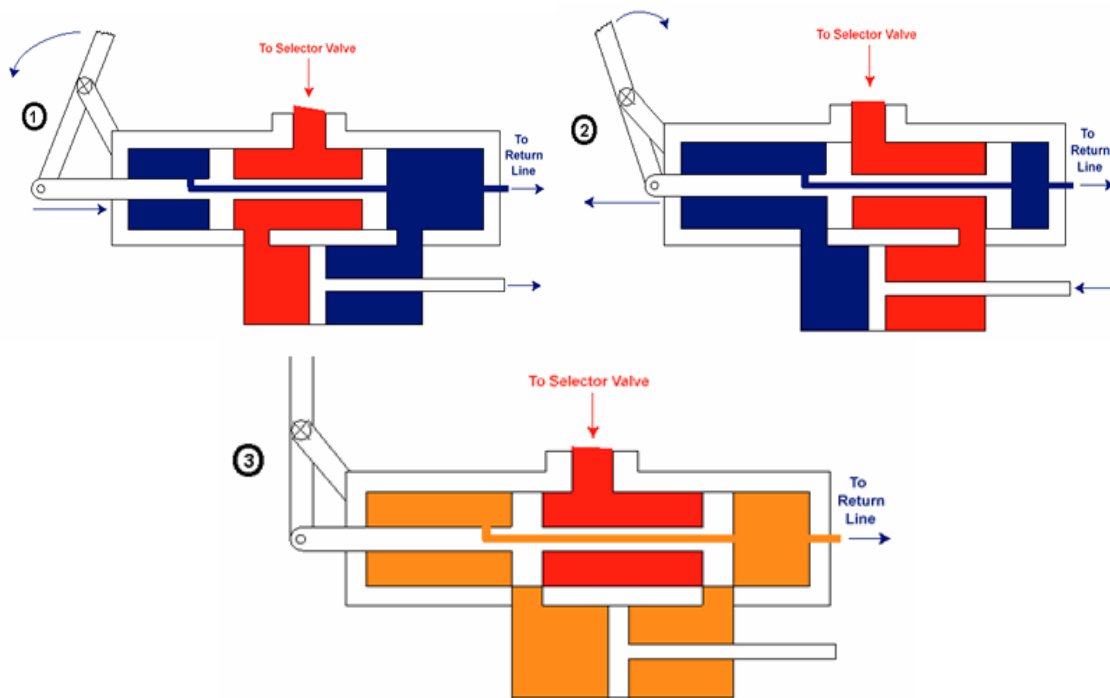

Fig 3.7 Piston type selector valves operating principle

### Poppet Type – Stacked Poppet

In this type of valve, any movement of the handle (at the lower right of the diagram) changes the camshaft and cam settings, thereby opening and closing the poppet valves

and letting high and low pressure oil to the proper sides of the actuating cylinder and return line, respectively.

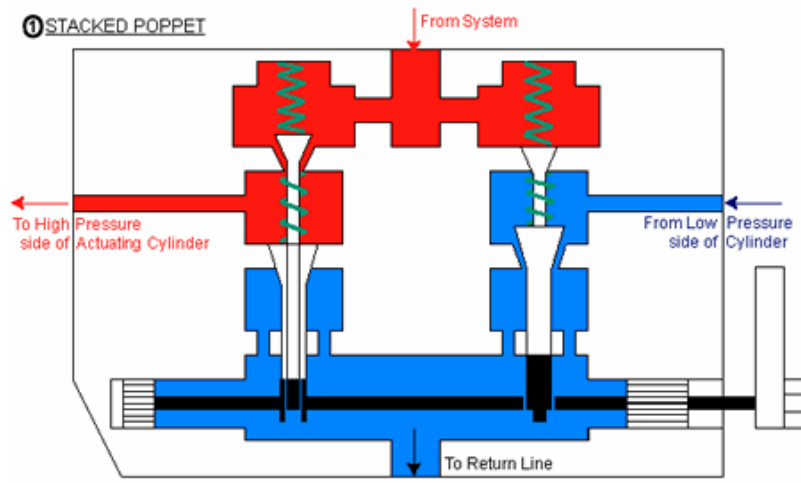

Fig 3.8 Stacked poppet type selector valves operating principle

These mechanical type selector valves require a fair amount of tubing. In order to reduce the amount of tubing, electric switches have been used to operate solenoids which operate the selector valves. This has the added advantage of reducing the wasteful motions of pilot. This type of combined electronic circuits and hydraulic system is called *electro-hydraulics*.

### 3.8.3 Flow Restrictors

Since the speed of the actuating cylinder is determined by the rate of flow of the hydraulic fluid, we may need a device to control the rate of flow. This device is called a flow restrictor. Since none of the selector valves meter the flow, we must use the restrictor.

There are four types of restrictors used in aircrafts hydraulic system:

1. one way fixed restrictor
2. one way variable restrictor
3. two way fixed restrictor
4. two way variable restrictor

### One Way Fixed Restrictor

The One Way Fixed Restrictor is not used all the time, but, it is being used more than the other types of restrictors. It is a check valve type restrictor with a drilled hole through the seat to the other side of the check valve. When the flow pressure seats the check valve ball (i.e., flow moving from right to left), some of the fluid can still reach the other side through the drilled hole in the seat. However, since the hole size is fixed, the amount of fluid passing through the passage to the other side is also fixed.

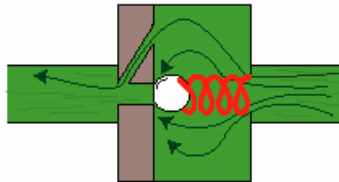

*Fig 3.9(a) One way fixed restrictor*

### Two Way Fixed Restrictor

The Two Way Fixed Restrictor is not used because it restricts the flow on the side of the restrictor where we want the flow to occur normally. Because the passage size is fixed, the amount of fluid moving from right to left, or vice versa, is fixed, as well.

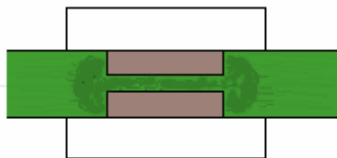

*Fig 3.9(b) Two way fixed restrictor*

### One Way Adjustable Restrictor

The One Way Adjustable Restrictor is being used nowadays. It is the same as the One Way Fixed Restrictor but the amount of fluid passed through the drilled opening in the seat is regulated by means of an adjustment screw.

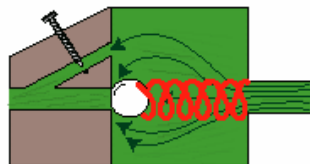

*Fig 3.9(c) One way adjustable restrictor*

### Two-way Adjustable Restrictor

The Two Way Adjustable Restrictor is the same as the Two Way Fixed Restrictor, but it also has an adjustable screw that can be used to further restrict the amount of hydraulic fluid passing through the opening.

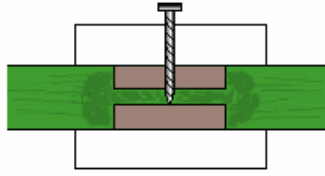

Fig 3.9(d) Two way adjustable restrictor

### 3.8.4 Pressure Regulation in Hydraulic Systems

If a system relief valve (SRV) were used to regulate pressure, it would have to be replaced in a very short time. This would be due to the overuse of the SRV and the failure of the spring's elasticity. If the SRV were used, the oil pushing on the spring-ball combination would cause tremendous vibrations and heat would be dissipated by the oil under high pressure attempting to push the ball away from the seat to get to the low pressure side. The range of operation of pressure regulator is defined by the difference in force required for bypass and the force required at actuation. And the dual purpose of this pressure regulator is to reduce the load on the hydraulic pump when not needed and to keep the hydraulic pressure within the operating range of the hydraulic system.

#### Douglass Pressure Regulator

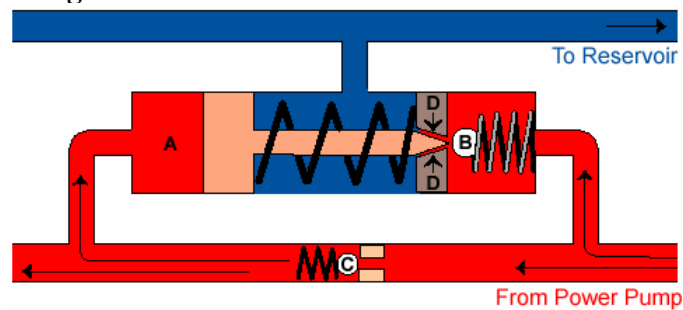

Fig.3.10 Douglass pressure regulator

When an actuating cylinder finishes its motion and stops, a high pressure will be felt through the system. If so, this high pressure oil coming from the power pump (right side of diagram) will keep check valve C open and also act on piston A. In its movement, piston A pushes Ball B off seat D. The oil, taking the passage of least resistance, goes through passage D into the center chamber (colored blue) back to the reservoir. The pressure on the right side of check valve C will drop and will be less than the pressure on the left side of C, therefore, causing the ball to seat itself in check valve C. When the hydraulic system pressure drops, the pressure on piston A decreases, causing a decrease

in pressure on B as well. The path of least resistance through D will close and the oil will move in the direction towards check valve C. Now, because the pressure on the right side of C is greater than on the left of C, the check valve will be forced to open and the oil will move toward the selector valve side of the system (left side of diagram).

## 3.9 Principles of Hydraulic Circuits

### 3.9.1 Synchronizing circuits

#### **Introduction**

During aircraft turns or manoeuvres, if wing air loads on one wing are greater than loads on the other wing, and, we attempt to sweep the wings back or sweep them forward, these motions will occur so unevenly that probable loss of aircraft and pilot will result. Therefore, if we want to synchronize our sweepback motion, we must use devices called flow equalizers.

Another example where flow equalizers are needed is in case of air-to-air missile attack. Suppose our selector valve is set to neutral and we try to get away from a rocket missile by turning right or left. The pressure forces on the wings would be so unequal that the wing actuating cylinder (of the wing undergoing the smaller turn radius) would act as a pump, since its greater pressure loading would cause wing sweepback. The hydraulic fluid would be pushed out of one cylinder and the only path that it could take would be to the other wing's actuating cylinder, causing that cylinder's wing to go in the opposite direction to that of the first wing. This would be catastrophic.

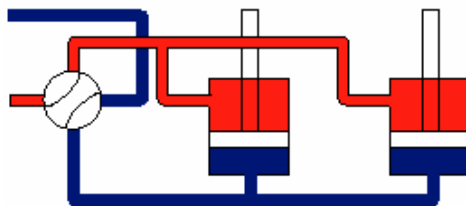

*Fig.3.11 Synchronized circuit diagram*

*If a downward force is applied to the left piston and the selector valve is closed, the oil is forced into the right cylinder causing the right piston to move up--a motion opposite to what is needed.*

If a downward force is applied to the left piston and the selector valve is closed, the oil is forced into the right cylinder causing the right piston to move up--a motion opposite to what is needed.

### 3.9.2 Sequencing Circuits

These circuits are used to cause certain operations to occur in a particular sequence. Sequencing circuits have been used, for example, for the complete ejection of a pilot from the plane. The sequencing valve is such that it sends hydraulic fluid through the valve to the other sequencing valves and actuating cylinders. As the piston rod (of the extreme left cylinder) moves upward, it activates the sequencing valve releasing hydraulic fluid to the next cylinder.

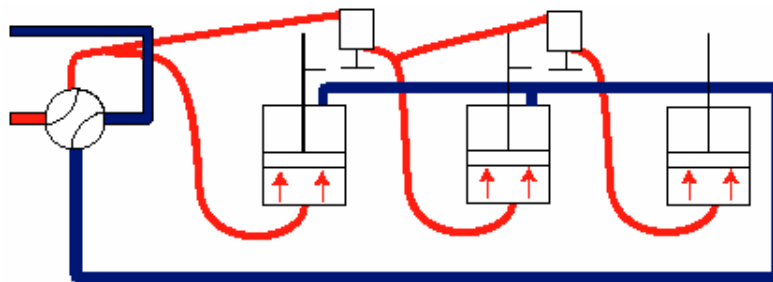

*Fig.3.12 Hydraulic circuit sequence diagram*

#### **Sequencing Valve Operation**

As the piston in actuating cylinder moves upward from the bottom stroke, it hits the rod of the sequencing valve as shown in the figure below. The rod, in turn, moves up into the sequencing valve pushing the poppet up and releases the hydraulic fluid from the holding side (upper chamber) to the releasing side (middle chamber), permitting it to go to the next cylinder and sequencing valve.

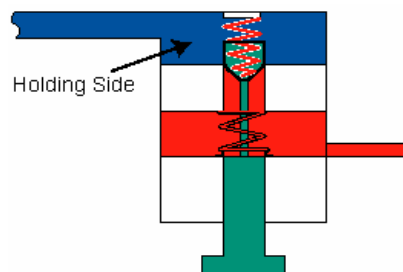

*Fig.3.13 Sequencing valve operation diagram*

## 3.10 Aircraft Hydraulic System Circuit Category

Every aircraft hydraulic system circuit has two major subsystems; the *power section or supply circuit*, and *actuating section or consumer circuit*. The power section provides for fluid flow, regulates and limits pressure, and carries fluid to various selector valves in the system. The actuating subsystems are those sections containing various operating units, such as wing flaps, landing gear, brake, boost system and steering mechanisms.

### 3.10.1 Hydraulic System Supply Circuit

#### **Purpose of Supply Circuit and Requirements to be met**

Supply circuit is intended to feed the required amount of working fluid at the desired pressure to the consumers. It should meet the following specific requirements:

- sufficient power and energy capacity of the sources which ensure required rate of operation in controlled mechanisms;
- filtration of the working fluid;
- limitation of working fluid pressure in the system by a preset level;
- unloading of pump when the consumers are not engaged.

Meant by *unloading of pumps* is the change-over to minimum power mode when the consumers do not operate. The purpose of unloading hydraulic pump is to preclude premature wear owing to prolonged operation at maximum power as to considerably reduce irrational consumption of energy for driving the pump. As transpires from equation

$N = P \cdot Q$ , unloading may be controlled in three ways:

- Without changing the pump delivery rate ( $Q = \text{const.}$ ), decrease the pressure at its outlet to minimum ( $P \approx 0$ ) i.e. make it operate idle.
- While maintaining the pressure behind the pump constant and equal to the working pressure in the system ( $P = \text{const.}$ ), decrease the delivery rate of the pump to minimum ( $Q \approx 0$ ).
- While cutting out the pump, reduce simultaneously the pressure and delivery rate to zero ( $Q \approx P \approx 0$ ).

## Schematic Patterns of Supply Circuits

Depending on the pump unloading method, the following supply circuit patterns are used:

- with a constant pump delivery rate and unloading automatic unit;
- with a variable pump delivery;
- with a constant pump delivery rate and pump engagement/disengagement switch.

### Example of Supply Circuit with Constant Pump Delivery and Automatic Relief Unit

To ensure operation of the hydraulic pump irrespective of flight altitude and to improve its cavitation characteristics, the hydraulic tank is pressurized. For this purpose, use is made of gas (air) bled from the engine compressor or neutral gas fed to the hydraulic tank from special bottles. The neutral gas used is usually *nitrogen* which, owing to its inert properties, increases fire resistance of the system and precludes oxidation of the fluid. This hydraulic line pressurization line includes gas filter [GF] for cleaning the gas, gas reducer [GR] to reduce the pressure, and non-return valve [NRV] which prevents release of air from the hydraulic tank at stoppage of the engine.

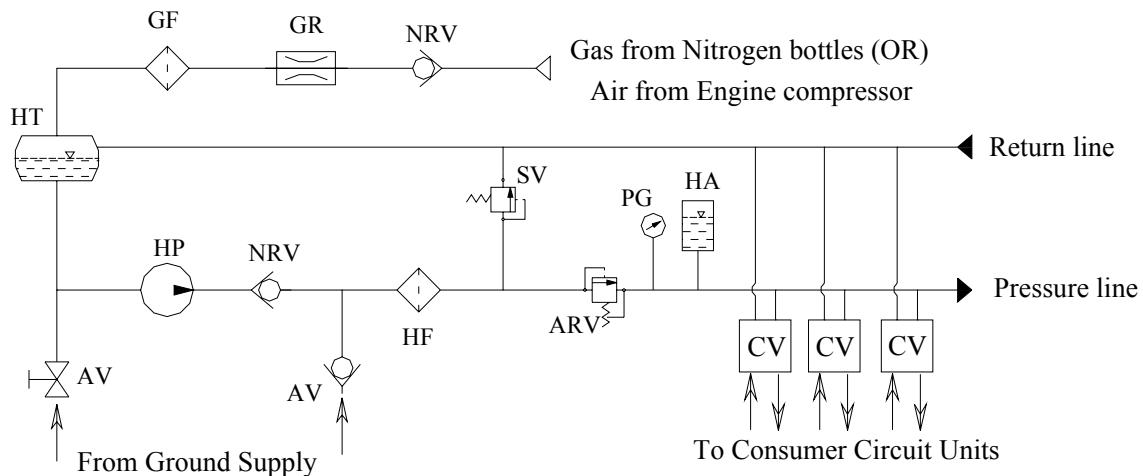

Fig. 3.14 Schematic diagram of supply circuit with constant displacement pump and automatic relief unit

As shown in Fig. 3.1, hydraulic fluid is fed from hydraulic tank to the input cavity of hydraulic pump [HP]. The fluid from hydraulic pump is supplied under pressure through hydraulic filter, where it is cleaned, then to control valves [CV] of the consumer circuit. To check operation of the system on the ground with the engine dead, the circuit includes aircraft valves [AV] for ground supply of fluid. Connected in parallel to the hydraulic pump in the circuit is hydraulic accumulator [HA] which is a bottle. When the aircraft

valve is open, the fluid is pushed by the compressed nitrogen energy from the hydraulic accumulator in to the system to boost the hydraulic pump supply. Thus, the hydraulic accumulator in this case increases the power of hydraulic system. Also in case of failure of the hydraulic pump, HA is used as an emergency energy source.

The hydraulic pump HP is unloaded in this circuit by means of automatic unloading unit. When a maximum pressure is reached in the circuit, the automatic relief valve [ARV] connects the pressure line upstream of the unit to the hydraulic tank. In this case, the fluid delivered by the pump is returned to the tank. A non-return valve is installed in this automatic relief unit to preclude a pressure drop in the idle duty of pump.

When the pressure in HA drops below the minimum required pressure amount, the unloading unit disconnects supply line of the pump from hydraulic tank and the pump again starts to deliver fluid in to HA increasing the pressure up to maximum. The pressure range is selected to preclude frequent change-over of the pump idle to working duty in case of internal leakage of the system. But frequent change-over leads to drastic oscillations of pressure in the system, and hence, to fatigue destruction of pipelines and units. Also to preclude overpressure in the system in case of failure of the ARV, safety valve [SV] is installed in the circuit. This safety valve connects high pressure line to the return line to cutoff further increase in the exceeding pressure. Fluid pressure in the hydraulic system line is measured by a pressure gauge [PG]. Also to check other operations of the system, flow rate transmitters, temperature pickups, etc., can be connected to the aircraft hydraulic systems.

### 3.10.2 Hydraulic System Consumer Circuit

#### **Purpose of Consumer Circuits**

Consumer circuits are used to feed hydraulic energy from the supply circuit through control and actuating devices to convert it into mechanical energy of different controls. Consumer circuit comprises a control device (valve), actuating device (actuating cylinder, hydromotor) and pipelines. In addition to these obligatory devices, consumer drive circuits comprise various additional units. They are installed in order to:

- ➡ increase reliability and survivability of the system;

- adjust the movement of actuating devices and pressure in front of them;
- fix, synchronize and ensure a required sequence of operation of the actuating devices.

Depending on the controlled object operating principle, consumer circuits are divided into:

**discrete control systems** which include landing gear retraction/extension control systems, flap, cargo hatch door, air brake control systems, etc., i.e., the systems featuring two or several fixed displacements, for instance, from the extended to the retracted position and vice versa;

**continuous action systems** which include systems for controlling hydraulic booster, variable sweep wing, nose wheels steering, system for adjusting air intakes, etc., i.e., systems which fix the controlled object at any required position (the variable sweep wing control system may be of the discrete type also).

## Chapter Four

---

### 4. EXISTING Mi-24 and Mi-35 HELICOPTERS HYDRAULIC SYSTEM

#### 4.1 General System Category

Generally Mi-24 and Mi-35 helicopter's hydraulic system consist of main, auxiliary and utility hydraulic sub-systems.

##### 4.1.1 Main and Auxiliary Hydraulic Sub-System

The main and auxiliary hydraulic sub-system is intended for powering the hydraulic boosters operation in the longitudinal, lateral, directional and collective pitch linkages. Additionally, the main hydraulic system is also used for unlocking the hydraulic cylinder of collective pitch and throttle-control friction clutch and *EMERGENCY EXTENSION OF THE LANDING GEAR*. But this main hydraulic sub-system is designed for a stand-by system in the extension of landing gear.

The system uses the principle of duplicating the units and pipes of the main hydraulic sub-system by those of the auxiliary hydraulic sub-system, except for the pipes and solenoid operated valves selecting the KAY-110/115 boosters to the combined control mode in conjunction with the autopilot, as well as for the collective pitch and throttle control unlocking cylinder and the landing gear emergency extension two-position solenoid-operated valve (ГA-165). These units are installed only in the main hydraulic sub-system.

The auxiliary hydraulic system additionally incorporates two duplicated auxiliary system selection valves connected in series to each other. These valves select the *stand-by auxiliary system operation* during the main system pressure-drop.

##### 4.1.2 Utility Hydraulic Sub-System

The utility Hydraulic sub-system is intended for powering of:-

- a. landing gear retraction and extension
- b. the main landing gear door locks operating cylinders
- c. directional control damper

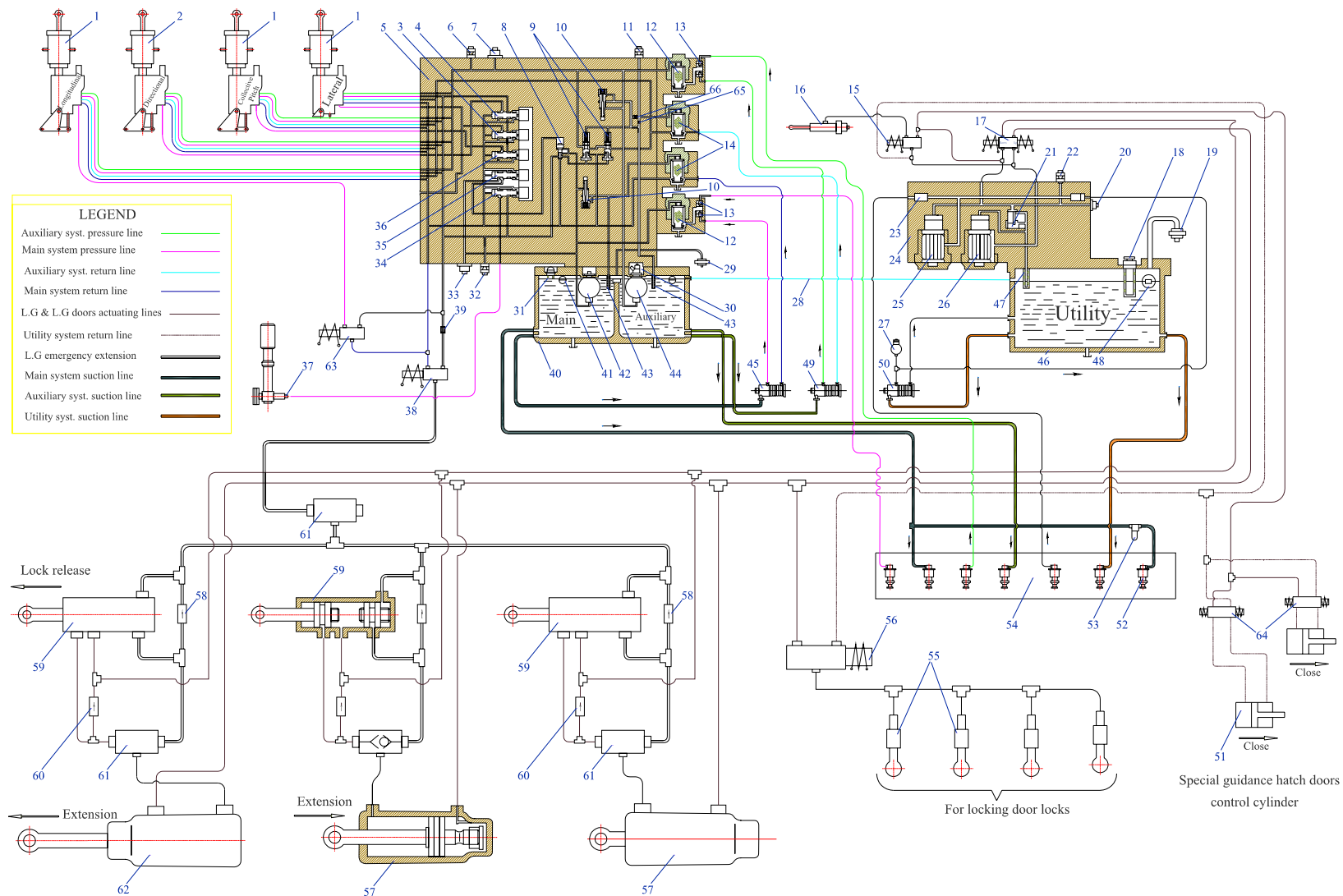

Fig 4.1(a) Overall hydraulic system block diagram for Mi-24 helicopters

**Fig. 4.1(a)**

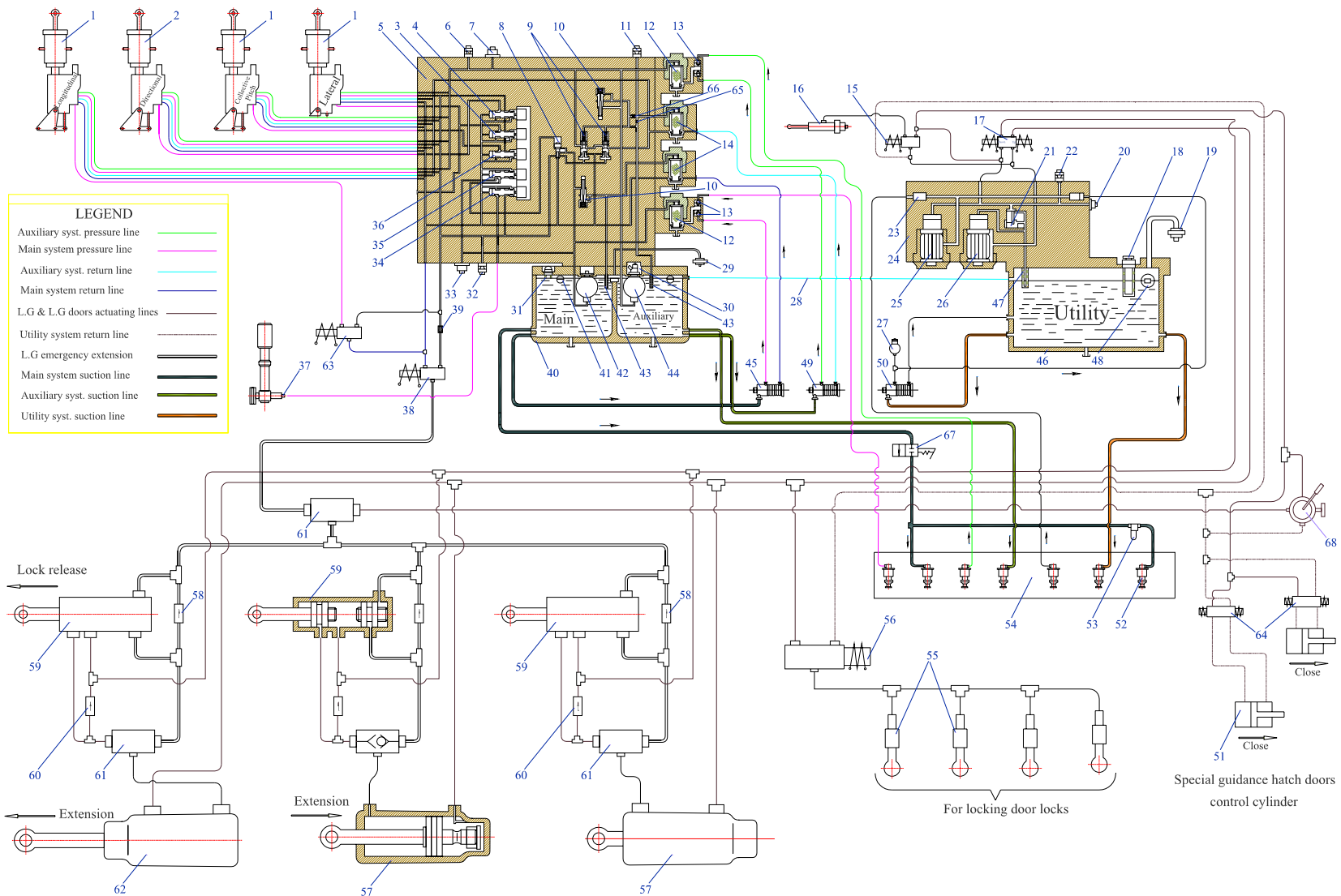

Fig 4.1(b) Overall hydraulic system block diagram for Mi-35 helicopters

**Fig. 4.1(b)**

Table 4.1 Description to drawing numbers in the circuit diagrams of chapter 4 and 6

| Drwg. №. | Description                                      | Remark   |
|----------|--|--|
| 1        | Hydraulic boosters/Amplifiers (KAY-110/115)      | Used for longitudinal, collective pitch and lateral control              |
| 2        | Hydraulic booster/Amplifier (KAY-110/115)        | With spring act. shifting mechanism                                      |
| 3        | Solenoid operated valve                          | Governs changing of lateral control booster to combined control mode     |
| 4        | Solenoid operated valve                          | Governs changing of directional control booster to combined control mode |
| 5        | Hydraulic distribution unit (АГС-60А)            |  |
| 6        | Pressure indicator (MCT-55AC)                    |  |
| 7        | Auxiliary system pressure transmitter (ИДТ-100)  |  |
| 8        | Main system cut-off valve                        |  |
| 9        | Auxiliary system selection valves                |  |
| 10       | Pressure relief valves                           |  |
| 11       | Pressure indicator (MCTB-0.4C)                   | To warn if the auxiliary system is not ready or functional               |
| 12       | Filters  | For main and auxiliary systems   |
| 13       | One way check valves                             |  |
| 14       | Filters  | On drain lines   |
| 15       | Solenoid operated valve (ГА-192)                 | Governs the hydraulic damper (16)  |
| 16       | Hydraulic damper (СДВ-5000-ОА)                   | Used for damping directional control pedal's displacement                |
| 17       | Three position solenoid operated valve (ГА142/2) | Governs landing gear extension and retraction                            |
| 18       | Filler neck                                      |  |
| 19       | Tank drain filter (31ВФ3А)                       |  |
| 20       | Inductive pressure transmitter (ИДТ-100)         | For utility system operation   |
| 21       | Pressure relief valve                            |  |

|    |  |  |
|----|--|--|
| 22 | Pressure warning unit (MCT-55AC)             |  |
| 23 | Check valves                                 |  |
| 24 | Hydraulic distribution unit (БГ-13-1)        | Mainly for utility system  |
| 25 | Filter                                       |  |
| 26 | Filter                                       |  |
| 27 | Hydraulic accumulator (15-5303-10/1)         |  |
| 28 | Hydraulic tanks interconnecting pipeline     |  |
| 29 | Tank drain filter (31BF3A)                   |  |
| 30 | Pressure warning unit (MCT-28AC)             | To give signal when nitrogen pressure is less than 28 kg/cm <sup>2</sup>                         |
| 31 | Filler neck                                  |  |
| 32 | Pressure indicator (MCT-55AC)                |  |
| 33 | Inductive pressure transmitter (ИДТ-100)     | For main system operation  |
| 34 | Solenoid operated valve                      | To govern unlocking of collective pitch and throttle control lever                               |
| 35 | Solenoid operated valve                      | For governing main system cutoff valve (8)   |
| 36 | Solenoid operated valve                      | For setting main rotor collective pitch control lever hydraulic booster to combined control mode |
| 37 | Friction clutch                              | For unlocking cylinder of collective pitch and throttle control lever                            |
| 38 | Two position solenoid operated valve (ГА165) |  |
| 39 | Flow restrictor                              |  |
| 40 | Hydraulic tank                               | For main and auxiliary system  |
| 41 | Fluid level indicator (gauge glass)          |  |
| 42 | Hydraulic accumulator                        |  |
| 43 | Foam suppressor                              |  |
| 44 | Hydraulic accumulator                        |  |
| 45 | Main hydraulic system pump (НП92А-4)         | Variable output pump   |

|         |  |  |
|---------|--|--|
| 46      | Hydraulic tank   | For utility system   |
| 47      | Foam suppressor  |  |
| 48      | Fluid level indicator (gauge glass)                                  |  |
| 49      | Auxiliary hydr. system pump (HII92A-4)                               | Variable output pump   |
| 50      | Utility hydr. system pump (HII92A-4)                                 | Variable output pump   |
| 51      | Special hatch doors control cylinder                                 |  |
| 52      | External connection for hydraulic pressure filling unit              |  |
| 53      | Filter (8Д2.966.015-2)   | To filter the fluid filling directly from external unit to the main tank |
| 54      | Ext. panel with valves for connection of ground hydraulic power unit |  |
| 55      | Door locks operating cylinder  | For locking released cylinders   |
| 56      | Solenoid operated valve (ГA192)                                      | To govern the main L.G door locks operating cylinder                     |
| 57      | Main L.G legs actuating cylinder                                     |  |
| 58      | Check valves (OK6A)  |  |
| 59      | L.G up-lock hydraulic cylinder                                       |  |
| 60      | Check valves (OK8A)  |  |
| 61a,b,c | Shuttle valves (YГ97-7)  | To be installed (Easily available spare)                                 |
| 62      | Nose L.G leg actuating cylinder                                      |  |
| 63      | Solenoid operated valve (ГA192)                                      | Governs changing of longit. control booster to combined control mode     |
| 64      | Two position solenoid operated valve (ГA185Y)                        |  |
| 65      | Chock  |  |
| 66      | Permissive valve   |  |
| 67a,b,c | Cutoff valve   | To be installed near the tank outlet                                     |
| 68      | Manual L.G emergency lever   | Only installed on Mi-35 helicopters                                      |
| 69      | Three position sol. op. valve (ГA163Y/16)                            | Only installed on Mi-35 helicopters                                      |
| 70      | Operator's control stick expandable rods                             | Only installed on Mi-35 helicopters                                      |

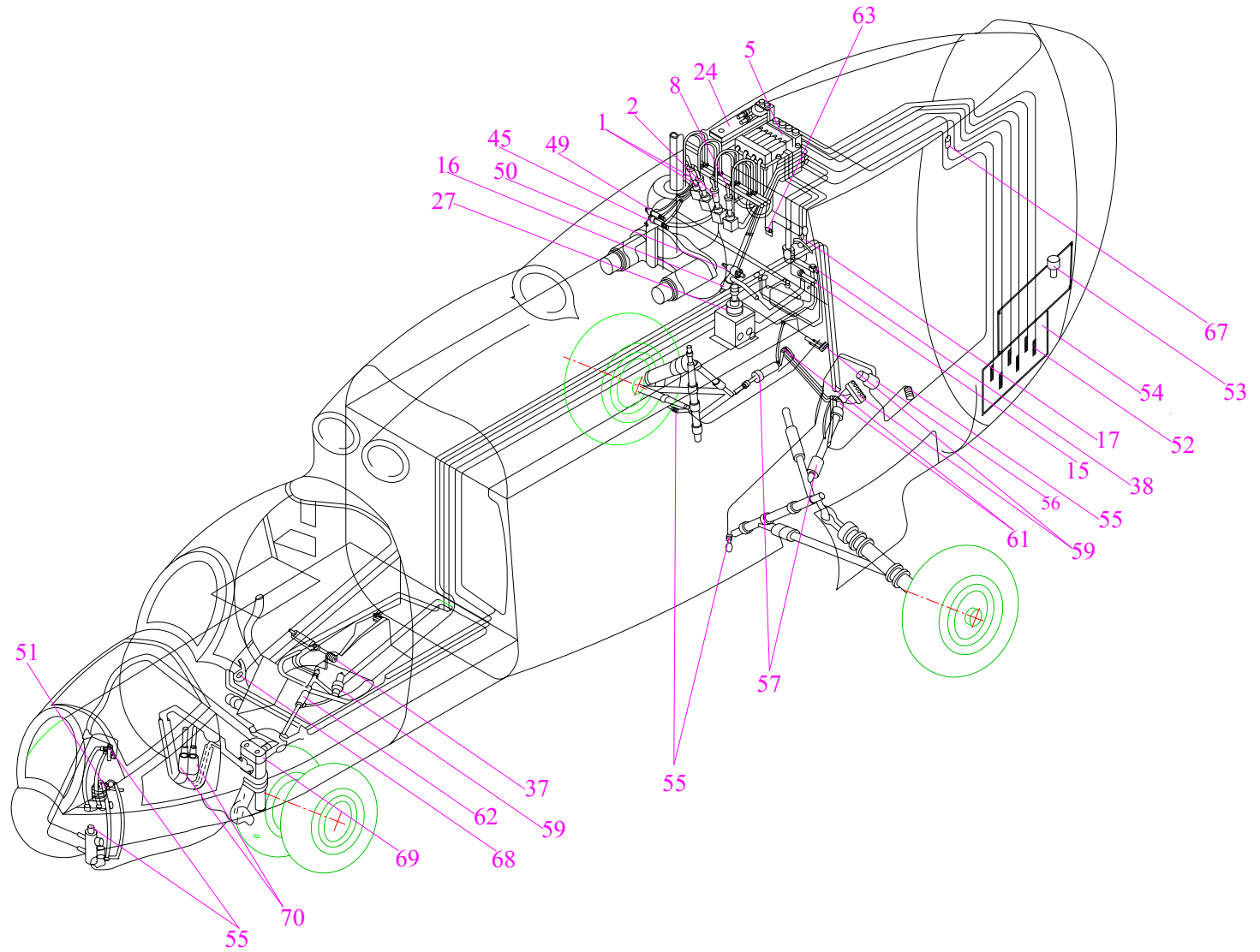

Fig 4.2 Arrangement of hydraulic units in the helicopter configuration

- d. expandable hydraulically operated rods engaging the operators cyclic pitch control stick with main control linkage, and
- e. the guidance device fairing doors cylinder operation.

Among the stated purpose of this utility sub-system, the main operation used on both Mi-24 and Mi-35 helicopters is for landing gear extension and retraction system. When this utility hydraulic system failed to extend the landing gear, another stand-by system is used to extend the landing gear. This stand-by system is the main hydraulic system, the main function of which is to power the flight controlling system of the helicopter.

## 4.2 Hydraulic System Units and Components in Mi-24 and Mi-35

The helicopters are equipped with a closed-center hydraulic power system that has two hydraulic packages, three pumps, different valves, ground connectors, and associated electrical and mechanical components. The system supplies hydraulic power to the hydraulic actuators that control the motion to operate the guidance device and landing gear. To do this; different components or units are incorporated in the system.

### 4.2.1 AFC-60A Hydraulic Distribution Unit

The AFC-60A hydraulic unit (Fig.4.3) is intended for storage, filtration and distribution of the main and auxiliary hydraulic systems fluid to the KAY-110/115 flight control boosters and the solenoid-operated valves governing the collective pitch and throttle control lever lock, and landing gear emergency extension from the main hydraulic system. It is installed in the main gearbox compartment adjacent to the pumps and boosters.

This hydraulic unit mainly consists of a tank, distribution unit, a block of solenoid-operated valves and filters. The tank (40) ensures the storage and distribution of fluid in the main and auxiliary system. The tank internal space is separated by a partition into two similar sections one of which contains hydraulic fluid for the main and the second for the auxiliary hydraulic systems. The distribution unit contains two safety valves (9) for detaching the auxiliary system, valve (8) for detaching the main system, pressure relief valves (10a, 10b) of the main and auxiliary system, the permissive valve (66), the pipe

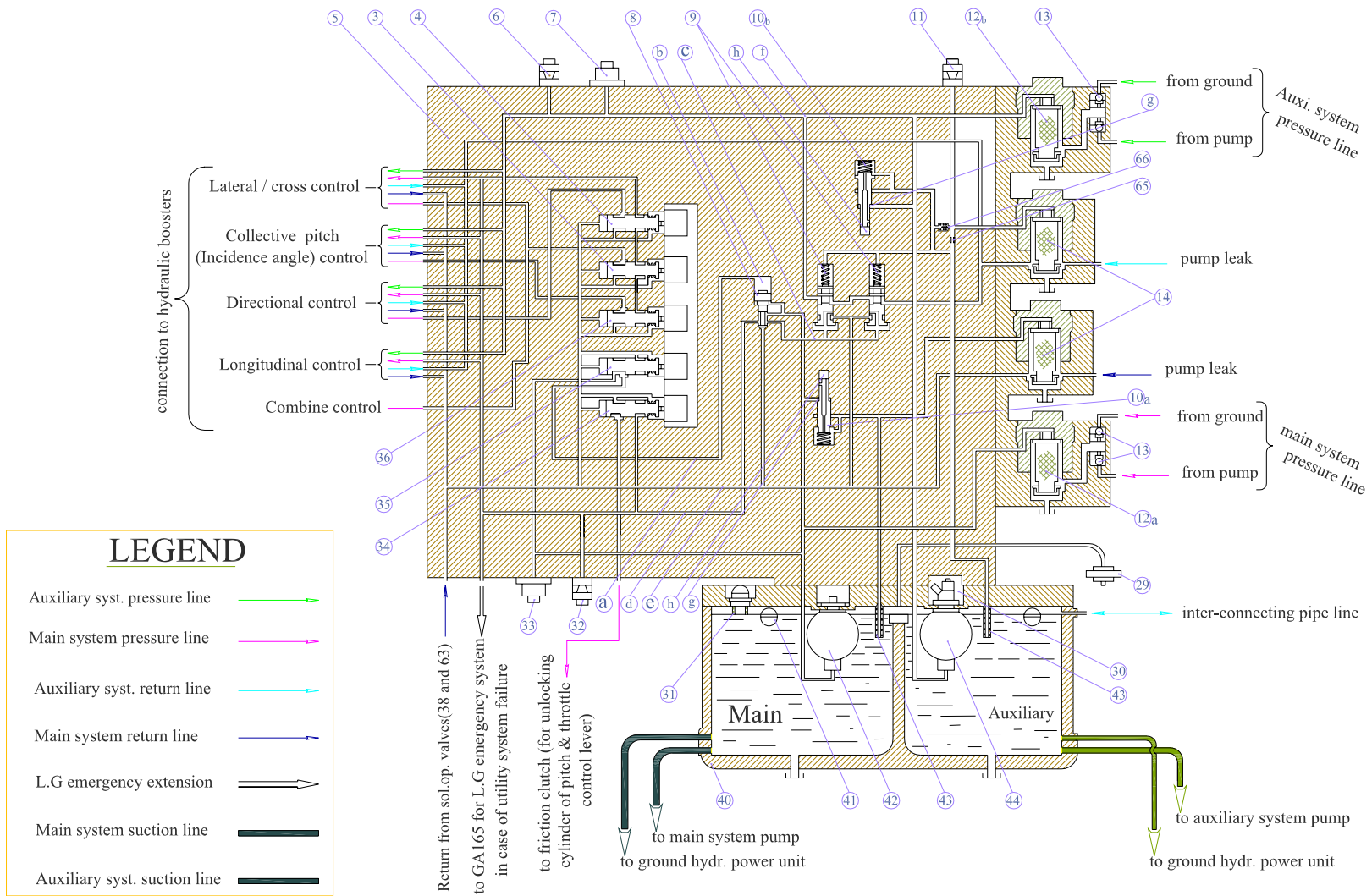

Fig 4.3 Main and auxiliary hydraulic sub-systems distribution block diagram

union connected to the foam suppressor (43), the chock (65) insertion, pressure indicator, and pieces of studs to fasten the blocks of the solenoid-operated valves and filters.

The block of solenoid-operated valve incorporates five solenoid-operated valves. Each valve has its own function in the main system. Valves (3), (4) and (36) serve for setting the lateral, directional and pitch control of the KAY-110/115 boosters to the combined control mode respectively. Valve (35) serves to cutoff the main hydraulic system. The other solenoid valve (34) serves to unlock the collective pitch and throttle control lever friction clutch, two small sized pressure warning switches (6, 32), two inductive pressure transmitters (7, 33) and connections. Also the filter unit incorporates four filters (two in the pressure lines and two in the return lines) and connections. In connection to each filter; four pressure connections are provided with check valves (13) consisting of bushing and balls.

#### **4.2.2 БГ-13-1 Hydraulic Distribution Unit**

The БГ-13-1 Hydraulic Unit is installed in the main gearbox compartment adjacent to the АГC-60А hydraulic unit. This unit is intended for storage, filtration and supply of hydraulic fluid to the control units governing the landing gear operating cylinders, the directional control hydraulic damper, the longitudinal and lateral control rods and the operating cylinders of guidance device. As shown in Fig.4.4; the БГ-13-1 hydraulic unit comprises the following main components: hydraulic tank (46), two fine filters (25,26), pressure relief valve (21), check valves (23), pressure transmitter (20) and pressure switch (22).

The tanks of both hydraulic units (АГC-60А and БГ-13-1) are interconnected by a pipe at the upper level of hydraulic fluid.

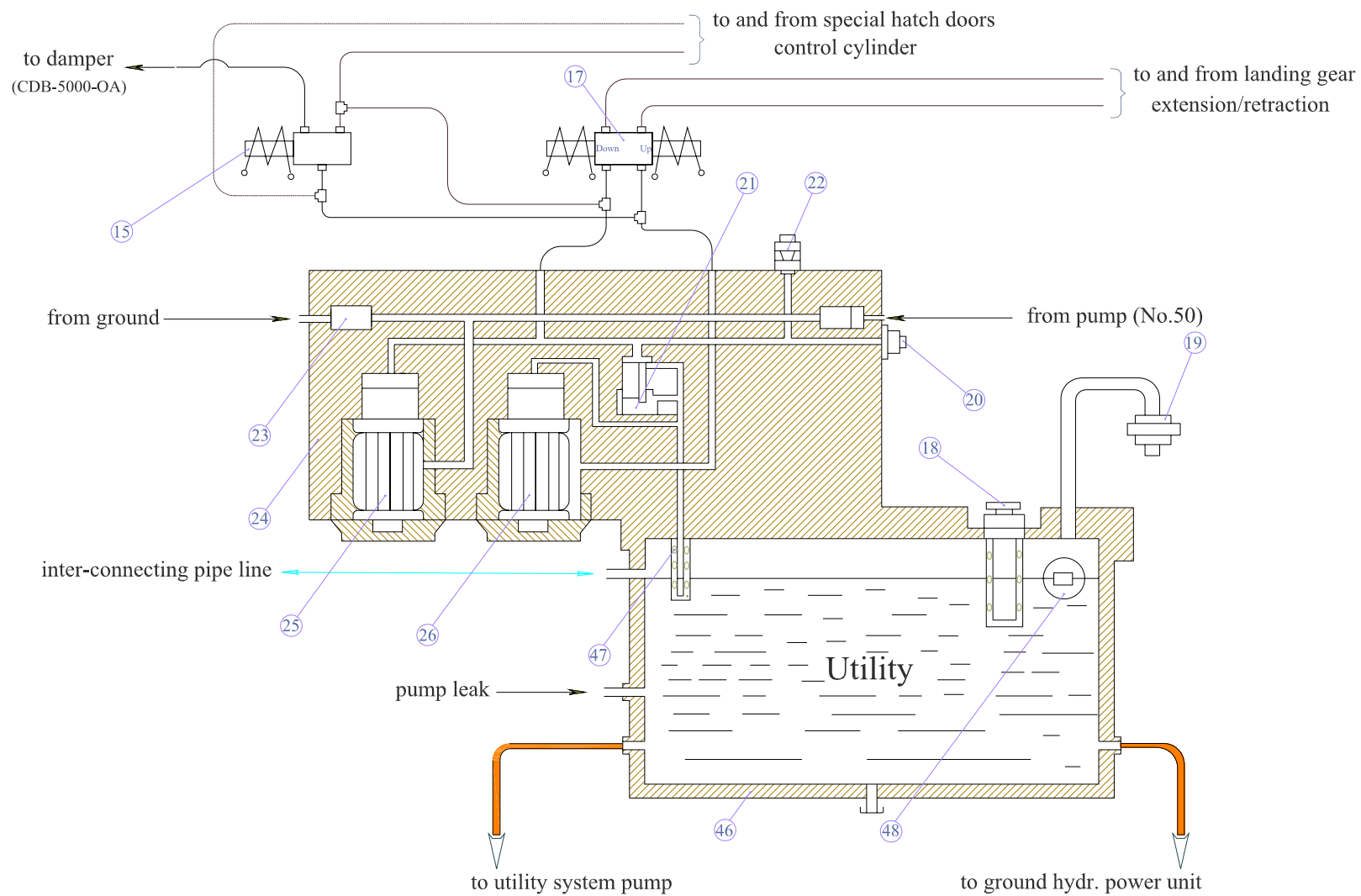

Fig 4.4 Utility sub-system hydraulic distribution block diagram

### 4.2.3 KAY-110/115 Booster

The KAY-110/115 booster is a hydraulic actuator with both mechanical and electrical controls intended for off-loading the manual controls. It employs a two-way operating circuit with the follow-up control. In the manual control mode the booster is hydraulically operated and governed by the mechanical control. But, in the case of a combined control mode; the booster remains hydraulically operated but governed by both the mechanical and electrical controls.

Changing-over to the combined control mode is carried out by the virtue of command pressure supplied from solenoid-operated valves of the helicopter hydraulic system. After this, the autopilot is automatically engaged and supplies holding signals to the KAY-110/115 booster signal converter. Each hydraulic actuator is connected by hoses to the main and auxiliary systems pressure and return line to operate successfully.

### 4.2.4 HP92A-4 Plunger Pump

Both Mi-24 and Mi-35 helicopters are equipped with three axial plunger type HPI92A-4 pumps installed at the main gearbox casing. It is a variable output pump with valve distribution intended for supplying pressurized hydraulic fluid to the helicopter hydraulic system.

*Table 4.1 Pump specification of Mi-24 and Mi-35 helicopters (Source<sup>[1, 4 & 11]</sup>)*

| <i>Description</i>   | <i>Specifications</i>        |                              |
|--|------------------------------|------------------------------|
|  | <i>Mi-24</i>                 | <i>Mi-35</i>                 |
| Power drive  | From main gearbox            | From main gearbox            |
| Driving shaft rotational speed:  |                              |                              |
| Maximum  | 2600 rpm                     | 2600 rpm                     |
| Rated  | 2500 rpm                     | 2500 rpm                     |
| Minimum  | 1200 rpm                     | 1200 rpm                     |
| Output (at output pressure of 65kgf/cm <sup>2</sup> , input pressure of 700 mm Hg and fluid temperature of 20±10 <sup>0</sup> c) | 30 ℓ/min                     | 30 ℓ/min                     |
| Output pressure at zero output flow  | (80 ± 5) kgf/cm <sup>2</sup> | (80 ± 5) kgf/cm <sup>2</sup> |
| Dry mass   | 10 kg                        | 10 kg                        |

#### 4.2.5 ГA142/2 Three-Position Solenoid- Operated Valve

The ГA142/2 three-position solenoid- operated valve (17) ensures supply of pressurized hydraulic fluid *to retract or extend the landing gear* with the help of utility hydraulic system (normal LG extension/retraction). The valve is remotely controlled using electric signals by the landing gear control lever at the pilot’s left hand front control console.

Table 4.2 ГA142/2 Solenoid-operated valve specification of both helicopters (Source<sup>[1, 4 & 11]</sup>)

| <b>Description</b>                   | <b>Specifications</b>         |                               |
|--------------------------------------|-------------------------------|-------------------------------|
|                                      | <b>Mi-24</b>                  | <b>Mi-35</b>                  |
| Rated operating pressure             | 220 kgf/cm <sup>2</sup>       | 220 kgf/cm <sup>2</sup>       |
| Minimum operating pressure           | 20 kgf/cm <sup>2</sup>        | 20 kgf/cm <sup>2</sup>        |
| Return line allowed counter pressure | 30 kgf/cm <sup>2</sup> , max. | 30 kgf/cm <sup>2</sup> , max. |
| Solenoid operating duty              | Continuous                    | Continuous                    |
| Power supply                         | DC                            | DC                            |
| Power voltage                        | (27± 2.7) v                   | (27± 2.7) v                   |

#### 4.2.6 ГA165 Two-Position Solenoid-Operated Valve

The ГA165 two-position solenoid-operated valve is intended for supplying pressurized hydraulic fluid into the landing gear extension line from the main hydraulic system distribution block incase of standby LG extension. This valve is remotely controlled by electric signals in both Mi-24 and Mi-35 helicopters.

Table 4.3 ГA165 solenoid operated valve specification of both helicopters (Source<sup>[1, 4 & 11]</sup>)

| <b>Description</b>                | <b>Specifications</b>   |                         |
|-----------------------------------|-------------------------|-------------------------|
|                                   | <b>Mi-24</b>            | <b>Mi-35</b>            |
| Rated operating pressure          | 210 kgf/cm <sup>2</sup> | 210 kgf/cm <sup>2</sup> |
| Power supply                      | DC                      | DC                      |
| Solenoid operating supply voltage | (27± 2.7) v             | (27± 2.7) v             |
| Current consumed                  | 15 A, max.              | 15 A, max.              |
| Operating time                    | 0.5 s, max.             | 0.5 s, max.             |
| Mass                              | 1.15 kg                 | 1.15 kg                 |

#### **4.2.7 ГA192 Solenoid Operated Valves**

The helicopters hydraulic system incorporates three-ГA192 solenoid operated valves. The first valve (63) is used to cut-in the longitudinal control KAY-110/115 booster in the combined control mode, the second valve (56) is intended for supplying pressurized hydraulic fluid to the main landing gear door locks operating cylinders, and the third valve (15) is used to cut in the CДB-5000-0A hydraulic damper.

### **4.3 Basic Steps in Operation of Hydraulic System in the Helicopters**

#### **4.3.1 Main and Auxiliary Hydraulic System Operation Principle**

Pump (45) (Ref. Fig. 4.1) sucks hydraulic fluid from hydraulic tank (40) of the main system and delivers it to АГC-60A hydraulic unit (5). Through the one way check valve (13) and filter (12) hydraulic fluid is simultaneously delivered to hydraulic accumulator (42), pressure-relief valve (10), main system cutoff valve (8), pressure transmitter (33) and main system cutoff solenoid-operated valve (35).

The working fluid from the annular groove of the de-energized solenoid operated valve flows through channel ‘‘a’’ to room ‘‘b’’ of the main system detaching valve (8) and moves the piston of the valve to the lower end position. The working fluid of the discharge tube flows from the annular groove of this main system detaching valve’s piston through channel ‘‘c’’ to the two parallel working safety system detaching valves (9) and moves the pistons against the spring to the upper position. At the same time, the working fluid flows through channel ‘‘d’’ to the solenoid operated valve (34), pressure indicator (32) and to the solenoid operated valves (4, 3, 36), and to the four hydraulic boosters. Simultaneously, hydraulic fluid comes to the two-position solenoid-operated valve (38) that opens for emergency extension of landing gear by the main system in case of a utility system failure.

After doing the work the fluid flows through channel ‘‘e’’ to filter (14), and through the foam suppressor diving tube (43) in to the tank (40). As the operating pressure in the main system holds the piston of the valve detaching the safety system (9) in the upper position, the working fluid coming from the pump of this auxiliary system flows through the one way

valve (13) and filter (12<sub>b</sub>) to the hydraulic accumulator (44) and to the annular groove of the valve detaching the auxiliary system, where it flows free through the filter (14), chock (65) and diving tube (43) into tank (40). In this way, when the main system is in operation, the auxiliary system functions in '*stand-by*' mode. Effect on operation of the controls may cause smooth variation of the system pressure within the range of  $(80 \pm 5)$  to  $(65 \pm 1)$  kgf/cm<sup>2</sup>. Checking the readiness of the auxiliary system is done by pressure indicators (11, 6) and inductive pressure transmitter (7). During the ground test of the changeover from the main system to the auxiliary system, the main system can be detached by solenoid-operated valve (35).

As shown in fig.4.3; when turning on solenoid operated valve (35), the piston of this valve moves to the left position, closes the discharge tube of the main system, and channel "a" gets connected with the recirculatory tube's channel "e" through the annular groove of the solenoid operated valve's piston. Thereby, the pressure in space "b" above the piston of the valve detaching the main system (8) reduces, and pressure from the discharge tube affects the piston only from the bottom. Thus, the piston moves to the upper position, closing the discharge tube from the channels "d" and "c". The channels "d" and "c" get in connection with the channel "e" and hence pressure reduces. Spring force affects the valve's detaching the auxiliary system (9), which moves the valve body to the bottom position, detaching this safety system's discharge tube from the recirculatory tube. The pressure of the discharge tube increases in channel "f" until it reaches operation pressure and hydraulic boosters changeover to the auxiliary system, working on normally. Changing over to the auxiliary system can be checked by the pressure indicators (6, 11, 32) and pressure transmitters (7, 33).

The degree of the pressure increase in the auxiliary system during the changeover is determined by permissive valve (66). The solenoid-operated valves (3, 4, 34, 36) are built in the main hydraulic system. Turning on the solenoid-operated valve (34) provides the friction clutch of the joint gas-lever with working fluid. When turning on the solenoid operated valves (3, 4, 36), the hydraulic amplifiers/boosters change over to combined control operation. The solenoid operated valve (4) changes the route or direction control system's

built-in hydraulic booster over to combined control operation. The solenoid-operated valve (3) changes the cross and longitudinal control system's built-in hydraulic booster over to combined control operation and the solenoid operated valve (36) changes the incidence angle control system's built-in hydraulic booster over to combined-control operation. If pressure of the operation fluid exceeds operation pressure in the main or auxiliary system, the system safety valve (10<sub>a</sub>) in the main system and the system safety valve (10<sub>b</sub>) in the auxiliary system become activated. The piston of the safety valve moves against the spring when the pressure increases as the pressure in room "g" is greater than spring force of the safety valve.

The piston moves against the spring as far as the orifice gets connected with the discharge tube. At this time, the fluid with high pressure gets into room "h" as well through the orifice and the main caliber of the piston and hence it pushes the piston on due to increase of the effective area. As the piston moves on, the discharge tube gets connected with recirculatory tube via the room "g" and it recycles the high-pressure fluid into the tank. Tank (40) is filled with the working fluid through filler hole (31). The fluid level in the tank can be seen on the glass gage (41). Hydraulic accumulators (42, 44) eliminate the pressure fluctuation caused by pulsation of the consumption peak and the pump.

#### **4.3.2 Utility Hydraulic System Operation Principle**

Pump (50) sucks hydraulic fluid from hydraulic tank (46) and simultaneously delivers it into hydraulic accumulator (27) and БГ-13-1 hydraulic unit (24). Hydraulic accumulator (27) installed downstream of pump (50) stores hydraulic energy to ensure accelerated retraction or extension of the landing gear. In addition, this hydraulic accumulator damps pressure oscillations produced by the pump.

Through check valve (23) and the filter, hydraulic fluid comes to three-position solenoid-operated valve (17) governing the landing gear extension and retraction, solenoid operated valve (15) governing directional control hydraulic damper (16) and solenoid-operated valve (64) governing the guidance device fairing doors. The *manual landing gear emergency*

*extension lever (68) is specially attached to this utility line for Mi-35 helicopters only.* Simultaneously hydraulic fluid comes to pressure-relief valve (21), inductive pressure transmitter (20) and pressure switch (22). Hydraulic fluid is returned from the units into tank (46) via filter (26) and foam suppressor (47). Tank (46) is linked to the auxiliary system tank by interconnecting pipe-line (28).

The system operating pressure is maintained within the limits of  $(80 \pm 5)$  to  $(65 \pm 1)$  kgf/cm<sup>2</sup>. The red annunciator comes on when the system pressure drops down to  $(55 \pm 3)$  kgf/cm<sup>2</sup>.

### **4.3.3 LG Extension and Retraction Operation Principle using Utility Sub-system**

Landing gear extension and retraction are operated by the use of a lever installed at the pilot's LH front control console. With the lever set to retraction and the LG selector switch to the MAIN (OCHOBH) position, hydraulic fluid comes from the utility system through three-position solenoid-operated valve (17) into one of the chambers of operating cylinders (57) and (62) to retract the landing gear. The piston in the cylinder forces hydraulic fluid through shuttle valves (61) and check valves (60) into tank (46). When the leg is retracted, the landing gear units are locked by the uplocks.

After the landing gear units are locked by the uplocks, the limit switches close the electric circuit to energize solenoid-operated valve (56) that operates to feed hydraulic fluid from the pressure line to main landing gear door locks operating cylinders (55).

With the lever set to extension, hydraulic fluid comes through three-position solenoid-operated valve (17) to the landing gear operating units. First, it comes to landing gear uplock hydraulic cylinders (59). After releasing the up locks, fluid comes through shuttle valves (61) into one of the chambers of operating cylinders (57, 62) to extend the landing gear. From the other chambers of these cylinders fluid is returned in to tank (46) via filter (26) and foam suppressor (47). Simultaneously the limit switch opens the circuit of solenoid-operated valve (56) upon releasing of the uplocks.

Being acted upon by the spring, the pilot valve of (56) shifts and communicates the chambers of main LG door locks operating cylinders (55) with the return line.

The landing gear can also be extended by the utility system with the use of the operator's controls. For this purpose, it is necessary to set the *LG DOWN* (ББИЦУСК) selector switch to the lower position.

#### **4.3.4 Operation Principle for Emergency Extension of L.G using Main Hydraulic System**

*In case of failure of the utility system, the landing gear is extended by the main system,* for which, the 'LG selector switch' on the pilot instrument board should be set to the "STANDBY (PE3EPB)" position. When such condition happens, the three-position solenoid-operated valve (17) is de-energized and in its turn communicates the landing gear operating lines with the return line. With the LG lever set to extension side, the two-position solenoid operated valve (38) operates to feed the main system hydraulic fluid to the landing gear operating units. To extend the landing gear; first, hydraulic fluid comes from the main system through ГA-165 valve and pipe to LG up-lock hydraulic cylinders to release the up-locks. After the up-locks are released, hydraulic fluid comes through shuttle valve (61) to one of the chambers of actuating cylinders (57) (62) to extend the landing gear, and further on in a way similar to that used in extension from the utility system.

From the other chambers of these cylinders, fluid is returned in to the utility tank via filter (26) and foam suppressor (47). Since the utility hydraulic unit (БГ-13-1) is located near АГC-60A main and auxiliary hydraulic unit, it is inter-connected by over flowing pipeline (28). The purpose of this inter-connecting pipe is to transfer fluid from the utility to auxiliary system tank.

The fluid, which is used to extend the landing gear from the main hydraulic system, is returned in to the main system tank via utility tank and auxiliary system tank. To do this, first of all the utility system tank which has got the volume capacity of about 12 to14 liters, should be full enough to allow the fluid flow via the interconnecting pipeline to auxiliary system tank.

## Chapter Five

---

### PROBLEM IDENTIFICATION

#### 5.1 Requirement Specification of the Problem

The need for this thesis is generated from the existing situation in flight performance characteristic of Mi-24 helicopters in Ethiopian Airforce. Also from the point of hydraulic system similarity in between Mi-24 and Mi-35 helicopters, additional assessment on Mi-35 helicopter is also required for generating the need of this thesis. The main step in this need analysis starts from the definition of problem statement. And this definition of the problem includes writing down a detailed problem statement which should express as specifically as possible what the technical assessment is intended to accomplish. To collect the required specifications and details of the helicopters, different manuals and prepared questionnaires are collected and presented in the previous three chapters to have a clear information about general helicopter theories and what the hydraulic system inside Mi-24 and Mi-35 helicopters look like. This chapter concentrates on the real and expected causes for problems to happen on Mi-24 and Mi-35 helicopters hydraulic system.

#### 5.2 Background of the Problem

As experience shows that next to engine failure, hydraulic failure is probably the most serious problem a pilot can encounter in helicopter flight. Hydraulic failure in a flying helicopter means loss of flight control function. On rotor wing aircrafts, hydraulic power is the most critical energy source and hence assessment on this system becomes a significant engineering concern. And also; due to the interdependencies on the electro-mechanical hydraulic system in Mi-24 and Mi-35 helicopters, failure on either of the sub-system affects the other.

Among the three hydraulic sub-systems in Mi-24 and Mi-35; the main hydraulic sub-system is used to power the main controlling system of the helicopter's movement, whereas utility hydraulic system is intended for powering of landing-gear retraction and extension, operating door lock cylinders and other directional control damping and

guiding devices. When this utility system failed, the main hydraulic system is used as a stand-by system to extend the landing gear. But directional control damping and guiding devices do not function at all if the utility system fails. Even if the purpose of emergency supply is to ensure that any single failure which can occur should not result in loss of control of the helicopter in flight or landing, some of the operations doesn't work effectively.

On the existing Mi-24 & Mi-35 helicopters flight operation it is observed that when the utility system failed, the landing gear is extended by selecting the '**L.G selector**' switch on pilot instrument board from 'MAIN SYSTEM' to the 'STANDBY' position.<sup>[2]</sup> At this time of emergency in flight, the pilot tries to extend landing gear by the main system. As described above while using this main hydraulic system for emergency landing, the helicopter loses its control and hence disturbance on the pilot and as a result crash occurs. To overcome this main system malfunction, the auxiliary system starts to operate. But this auxiliary hydraulic system can't extend the retracted landing gear for emergency landing using autorotation principle. In addition to this; if such a failure on the main and utility sub-system occurs in the enemy zone, the gunners in the cockpit can't counter-attack the enemies behind them because of guidance device malfunctioning. The other impact is on the pilot to control the directional movement of the helicopter due to the loss in pressure on hydraulic pedal. As shown practically on the existing in-hand Mi-24 and Mi-35 helicopters, there are also other problems that may lead the whole hydraulic system to fail. The other thing that should be considered is that, unlike other fighter airplanes there is no method of ejecting the chair while such failure happens to save pilot's life. Due to related conditions on the hydraulic failure, almost all of Mi-24 and some of Mi-35 helicopters in Ethiopian Airforce are grounded rather than flying until their expected life time.

### **5.3 Category of Hydraulic Failure that may occur**

There are different modes of hydraulic failures that lead the helicopters to crash. This is because; most helicopters use hydraulics to reduce the force required to move different mechanisms or controls in flight. Usually there is still a mechanical connection. In some

helicopters there might not be a mechanical connection, or the control forces may simply be too high for the pilot to overcome with muscle. Generally those sorts of helicopters will have redundant hydraulic systems. There are multiple causes for such hydraulic systems to fail. Because of different causes, the failures can be categorized in to:

- total hydraulic failure,
- partial hydraulic failure, and
- handover failure.

### **a) Total Hydraulic Failure**

Total hydraulic failure occurs when the main hydraulic controls in flight are not operational. When this failure occurs, the pilot will notice that the control boost has gone. For example; In the case of the cyclic and collective pitch control in helicopters, the pilot will also usually notice that they are connected, i.e. when the pilot moves one control, the feedback from the rotor system will also cause the corresponding control to move.

In some cases, the stick forces are low enough that the pilot can fly the helicopter with little difficulty. If the pilot has to fly for a significant amount of time before landing, he will probably be fatigued and it may be difficult to avoid over-controlling the helicopter while attempting to hover. The impact of such a failure is more on hovering flights than a running landing flights.

### **b) Partial Hydraulic Failure**

This type of hydraulic failure happens when one hydraulic servo fails, but the others continue to work. This means that the pilot controls are boosted in some parts of their movement, but not in others. Such a failure could easily result in an aircraft that is not flyable by the average pilot. This happens on the helicopters that are not provided with sufficient standby switches to allow the pilot to disable the failed hydraulic system. Such a failure also happens due to lack of a “failsafe” override system. In such a partial hydraulic failure, loss of the aircraft electrical system also causes a hydraulic system’s failure.

### **c) Handover Failure**

Another failure mode of a hydraulically boosted control system is that one of the servos could be driven to one extreme position or the other by a failure within the servo. This would result in an unflyable aircraft like Mi-24 helicopters at the present existing condition.

## **5.4 Causes for the Helicopters Hydraulic System Failure**

There are so many causes for the hydraulic system of the helicopters to fail. Among many of the causes regardless of the short-comings of the components are due to:

- damage of fluid flow line ( hose, pipe)
- electrical system failure that affects the solenoid-operated valves
- mechanical system failure and effect of other helicopter parts
- schedule on maintenance
- pilot or technician's skill and experience
- hydraulic fluid contamination
- environmental and altitude effects
- effect of failure in one sub-system on the other in the hydraulic circuit
- lack of sufficient alternative standby safety system, (or) improper design of hydraulic circuit.

### **5.4.1 Damage of Fluid Flow Lines**

Because of damage on fluid lines in the helicopter hydraulic system, as experience has shown that almost all the fluid flows out of the system, and as a result, the tank becomes empty. Hence, the whole operations in that circuit couldn't function as a result of the pressure lose due to lack of hydraulic fluid. Such a damage on the pipes and hoses may happen due to; cavitation, fluid hammer in pipes, internal surface corrosion and other effects.

### **Cavitation in the Hydraulic Lines**

Cavitation occurs when the hydraulic fluid moves within tubing or pipes at very fast speeds causing the absolute pressure of the liquid to drop drastically. This process occurs with little loss of heat. If the absolute pressure drops below the vapour pressure of the liquid, cavitation will form. This phenomenon is more serious in viscous liquids than in thin liquids. Cavitation causes separation of gases that are within the liquid (such as air or water vapour) from the hydraulic liquid itself. Bubbles would form and collapse. This cavitation could occur in the system in case of a liquid entering the suction side of a pump, the pressure would be low. For the liquid to move from one place to another, it would have to expend energy, thus causing a further decrease in pressure.

Formation of cavitation in the hydraulic system line has different effects. Among the main effects are:

- ◆ it can cause wearing out of parts in the system,
- ◆ it will be heard as noise (sometimes you hear it in your pipes...it's called line or water hammering),
- ◆ it will cause vibrations in the system,
- ◆ it will cause losses in efficiency of the hydraulic system,
- ◆ it can cause erratic motor operations,
- ◆ it will require replacement of parts much sooner than designed for.

### **Fluid Hammer in Hydraulic Lines**

In a long hydraulic pipe, when the flowing liquid is suddenly brought to rest by closing the valve or by any similar cause, there will be a sudden rise in pressure due to the momentum of fluid being inside. A pressure wave is transmitted along the pipe. A sudden rise in pressure has the effect of hammering action on the walls of the pipe. This phenomenon of sudden rise in pressure is known as *fluid hammer* or *hammer blow*. The magnitude of this pressure rise on the hydraulic line depends on:

- i) the speed at which the valves are closed by the operator
- ii) the velocity of flow in the system
- iii) the length of pipe in the helicopter hydraulic circuit, and
- iv) the elastic properties of the pipe material as well as that of the flowing fluid.

#### 5.4.2 Electrical and Mechanical Systems Failure

Both the utility and main sub-systems that are used for landing gear extension and retraction comprise solenoid operated valves. When the electrical system fails; the auxiliary system overtakes the function of the main system *except the landing gear, directional control damper and guidance device operations*. So failure of electrical system affects the proper operation on landing gear extension of Mi-24 helicopters. However, in case of Mi-35 helicopters utility system failure due to solenoid operated valves malfunctioning, the landing gear can be extended by the help of using *manual landing gear emergency extension system taking the fluid from the same utility line*. If there is a leakage or damage on the utility line, this manual landing gear extension lever does not function on Mi-35 also.

Mechanical failures of some adjacent components near the hydraulic line might have a cause for failure on the hydraulic system. For example; *as seen from Mi-24 hydraulic system, many hoses from AГC-60A and БГ-13-1 hydraulic units are interlinked and connected to the boosters, but these hoses are exposed to fluid leakage from the main rotor hub and blades*. After some time, the fluid that leaks on these hoses may affect performance and strength of the hose to resist the pressure inside.

In addition to the effect of external leakage from hub, *the effect of friction due to reciprocation of hydraulic boosters affect the improperly interlinked hoses connected to it*. As shown practically on Mi-24 helicopters; these hoses are not in a good position to protect from the effect of wear that leads to friction exposure. Also *on some Mi-24 helicopters, the pipeline that connects the hydraulic unit of AГC-60A to the friction clutch is exposed to mechanical damage during checkup and inspection of the system*. As we know, even scratches may become an initiation for pipe leakage. Therefore, such joints that are exposed to dents, scratches and other external loading could be one of the causes for the whole hydraulic system to fail.

### 5.4.3 Schedule on Maintenance

An improperly maintained hydraulic system can lead to component failures. But accident investigations have revealed that some operators are not testing the helicopter hydraulic systems in accordance with the rotorcraft flight manual (RFM) or published and approved guidelines <sup>[3]</sup>. Tests on some accident helicopters would have shown that the systems were malfunctioning or inoperative before flight.

There should be a periodical check for oil leaks and worn hoses even if the helicopter doesn't fly. But due to some inconvenience and complexity in maintenance on some lines there may not be a continuous checkup. For example; *in case of Mi-35 helicopter, the cutoff valve (67) is installed in the area that is not comfortable for ease of maintenance. Moreover, this unit is installed far away from the tank block without any valve in-between.* Probably if this line leaks due to internal damage or an attack from enemy, a complete hydraulic fluid leakage from the tank occurs.

### 5.4.4 Pilot or Technician's Skill and Experience

Checking all the hydraulic system performance before, during and after flight must be a major concern for a helicopter pilot. As experience shows, less experience or disturbance of the crew-person leads to unwanted failure of the helicopters. *For example; because of failure in the utility system, if the pilot selects the main switch to the auxiliary system due to the effect of lose in pressure of directional control damper in Mi-24 and Mi-35, it is not possible to extend the landing gear.* The other problem a pilot has to experience is on checking the pressure indicators before total sub-system failure occurs. Applying unnecessary sudden and impact loading also has a great impact on the system.

Improper fit at the adjacent joints during assembly is another cause of hydraulic system failure during flight. Carelessness on scheduled maintenance and inspection of the parts and fluid contamination during maintenance is the other effect on the hydraulic system failure during flight.

### **5.4.5 Hydraulic Fluid Contamination**

Experience has shown that trouble in a hydraulic system is inevitable whenever the liquid is allowed to become contaminated. The nature of the trouble, whether a simple malfunction or the complete destruction of a component, depends to some extent on the type of contaminant.

Two general contaminants that leads to trouble can be categorized in to:

- (1) *Abrasives*; including particles such as core sand, weld spatter, machining chips, and rust due to inner-surface corrosion.
- (2) *Nonabrasives*; including those resulting from oil oxidation, and soft particles worn or shredded from seals and other organic components.

### **5.4.6 Environmental and Altitude Effects**

Up, down and cross wind conditions have a great effect on controllability of the helicopter and hence the hydraulic power is affected. In the air, the faster the helicopter is moving, the greater the strength required to control the main rotor blades using swash plates. In such cases, the air load can easily be too great for the pilot to physically deploy it. Hence, higher loading due to environmental effect needs a higher pressure. This excessive pressure may lead the hydraulic system to fail.

Thinking of Bernoulli's principle; in the case of aircraft at altitude, the drop in pressure would cause separation of gas from liquid introducing bubbles of gas into the hydraulic system. Once bubbles are formed, they can remain stationary and act as a restriction to the flow, taking up space normally occupied by the liquid. This causes a resistance to the flow and increases the pressure inside the system. If the bubbles are moving, they will move into a higher pressure region (again Bernoulli's principle but in reverse). When the pressure increases, the bubbles are acted upon by this high external pressure which causes the bubbles to implode. This implosion generates pressure waves in all directions. Bubble collapse is not the problem but these high pressure waves can act like a small explosion. The other expected impact is temperature and different dynamic loads around the system units.

#### **5.4.7 Effect of Safety Circuit System incase of Other Sub-systems Failure**

As has already been described on the circuit diagram of Mi-24 and Mi-35; the purpose of the main hydraulic sub-system is to power the helicopter controls. But, on the process of landing gear extension using this main sub-system, the hydraulic fluid in the real failure does not return back to the system tank. It will rather flow to fill the utility system tank and then to the auxiliary tank, or flow out of the system through the open/damaged line. When this problem happens in flight, and the pilot used this main system to extend the landing gear for emergency purpose, he also *losses the main helicopter controls because of insufficient fluid in the main line*. During this event; the automatic selector valve is switched very fast to the auxiliary hydraulic sub-system to take over the helicopters control, but the *auxiliary sub-system doesn't operate the landing gear mechanism*. At this time of disturbance, the effect on the pilot's confidence on decision should be taken in to account. This is one of the main effects of one hydraulic sub-systems failure on the other sub-system in the circuit that leads these helicopters to crash. The effect of such a failure on landing gear extension leads to more surface deformation of the helicopter body even if it lands with autorotative vertical power-off descent that has been found to be nearly as effective as a parachute of the same diameter as the rotor disk.

#### **5.4.8 Lack of Sufficient Safety Circuit (Alternative Standby System for all)**

In both Mi-24 and Mi-35 helicopters, absence of any other standby safety system for directional control damper and guidance device mechanism is observed. *When the utility system fails, these two mechanisms couldn't operate to fulfill the required purpose*. That means; controlling the directional movement of the helicopter becomes more difficult for the pilot to complete the mission successfully. And also loosing the guidance device with out any other standby safety system has a great impact on the gunners in the cockpit.

Specially on Mi-24 helicopters hydraulic circuit, the *absence of any cutoff valve in between the main tank (40) and external panel* for ground hydraulic power unit (54) also leads to a complete outflow or leakage of fluid from the main tank. This leakage or

complete outflow of hydraulic fluid from the main tank through damaged pipeline happens due to *the inconvenience of the pipeline position for ease of maintenance and other exposure for damage due to an external attack from enemy*. Such a similar problem is also observed on the utility line with the ground supply unit. In case of Mi-35 helicopters, this problem is solved to some extent by placing a spring operated cutoff valve between the main tank and ground supply end. But as shown practically on the existing inhand helicopters, this intermediate spring operated valve is installed very far away from the main tank.

## Chapter Six

---

### SOLUTION PROPOSAL AND EVALUATION OF CONCEPT VARIANTS

#### 6.1 Introduction

As explained earlier in chapter five, there are different causes for the hydraulic system in the specified helicopters to fail. If this problem continues without solving it, a crash or other difficulties on flight occurs. Depending up on the type of problem happened, general solutions to the specific problems have to be taken in to account. For example; to avoid or reduce the effect of fluid hammering, a special consideration is required in reducing the speed at which the valves are closed during flight and ground hydraulic testing operations. Controlling the temperature around the hydraulic line can avoid formation of cavitation in the system. This implies the impact or dependency of other systems on it. So giving attention on the other system also improves the performance and efficiency of the hydraulic system to work effectively.

The hoses that are interlinked between the hydraulic units and boosters are properly arranged to reduce friction, effect of cavitation due to sharp bends and internal pressure rise in Mi-35 helicopters. This new proper modification of the hoses arrangement has to be installed on Mi-24 helicopters too. The other solution to keep these hoses in safe condition is putting a simple cover shield to protect the hoses from external leakage of oil from the main rotor hub joints. Putting a cover at the joint of friction clutch together with the hoses is an additional prevention of damage in that area.

Even if many considerations have been taken into account in the design of each component, we need to give special attention on proper maintenance of the overall system. For example; in the process of maintenance of the hydraulic system, the utmost attention should be paid to air tightness of system piping and continuous checkup.

#### 6.2 Hydraulic fluid control

Choosing the best hydraulic fluid for a given system can be a major task. So to assure proper system operation and to avoid damage to non-metallic components of the

hydraulic system, a great attention on fluid must be considered. Aircraft hydraulic system's fluid designed is virtually trouble-free if properly serviced. Proper fluids must not appreciably affect common aircraft metals (such as: aluminum, silver, zinc, magnesium, cadmium, iron, stainless steel, bronze, chromium, and others) as long as the fluids are kept free of contamination.

### **Contamination Check**

Whenever it is suspected that a hydraulic system has become contaminated, or the system has been operated at temperatures in excess of the specified maximum, a check of the system should be made. The filters in most hydraulic systems are designed to remove most foreign particles that are visible to the naked eye. Hydraulic liquid which appears clean to the naked eye may be contaminated to the point that it is unfit for use. Thus, visual inspection of the hydraulic liquid does not determine the total amount of contamination in the system. Large particles of impurities in the hydraulic system are indications that one or more components in the system are being subjected to excessive wear. Isolating the defective component requires a systematic process of elimination. Fluid returned to the reservoir may contain impurities from any part of the system. To determine which component is defective, liquid samples should be taken from the reservoir and various other locations in the system.

### **Contamination Control**

Filters provide adequate control of the contamination problem during all normal hydraulic system operations. Control of the size and amount of contamination entering the system from any other source is the responsibility of the people who service and maintain the equipment. Therefore, precautions should be taken to minimize contamination during maintenance, repair, and service operations. During operation of helicopter; care should be taken to avoid charging of hydraulic systems with polluted fluid. This can be controlled by cleaning and washing hydraulic system filters regularly. As an aid in controlling contamination, the following maintenance and servicing procedures should be followed at all times:

- Maintain all tools and the work area (workbenches and test equipment) in a clean, dirt-free condition.

- A suitable container should always be provided to receive the hydraulic liquid that is spilled during component removal or disassembly procedures.
- Before disconnecting hydraulic lines or fittings, clean the affected area with dry cleaning solvent.
- All hydraulic lines and fittings should be capped or plugged immediately after disconnecting.
- Before assembly of any hydraulic components, wash all parts in an approved dry cleaning solvent.
- After cleaning the parts in the dry cleaning solution dry the parts thoroughly and lubricate them with the recommended preservative or hydraulic liquid before assembly. Use only clean, lint- free cloths to wipe or dry the component parts.
- All seals and gaskets should be replaced during the re-assembly procedure. Use only those seals and gaskets recommended by the manufacturer.
- All parts should be connected with care to avoid stripping metal slivers from threaded areas. All fittings and lines should be installed and torqued in accordance with applicable technical instructions.
- All hydraulic servicing equipment should be kept clean and in good operating condition.

### **6.3 Solutions Proposed to Upgrade the Overall Hydraulic Circuit**

#### **(Regardless of avoiding the sources)**

As shown in the circuit diagram of fig.4.1(a) and 4.1(b); different sub-systems are used so as to fulfill the overall function of the existing hydraulic system to the specified helicopters. Now different intuitive and discursive solutions or ideas are presented on each sub-system so as to avoid or improve the defect shown on the circuit diagram of both Mi-24 and Mi-35 helicopters together.

#### **6.3.1 Solution Proposed to Avoid Probability of Complete Drain from the Tanks**

The external panel for ground hydraulic power unit is used for pressure filling and ground hydraulic testing before the engine starts to operate the pump. The line that connects this

pressure filling unit with the three tanks should be in a position to keep the fluid drain from main, auxiliary and utility tanks. To reduce the effect of complete drain from the main tank, a spring operated cutoff valve (67) is installed on Mi-35 helicopters. **Re-installing this valve nearby the tank outlet** is a better way for avoiding the drain due to damage on that pipeline. Since the pipeline from the auxiliary and utility tank to the ground supply unit is placed in the same area with the line from the main tank; installing another spring operated cutoff valve at the outlet of the two tanks can also avoid the probability of complete outflow of hydraulic fluid from both tanks.

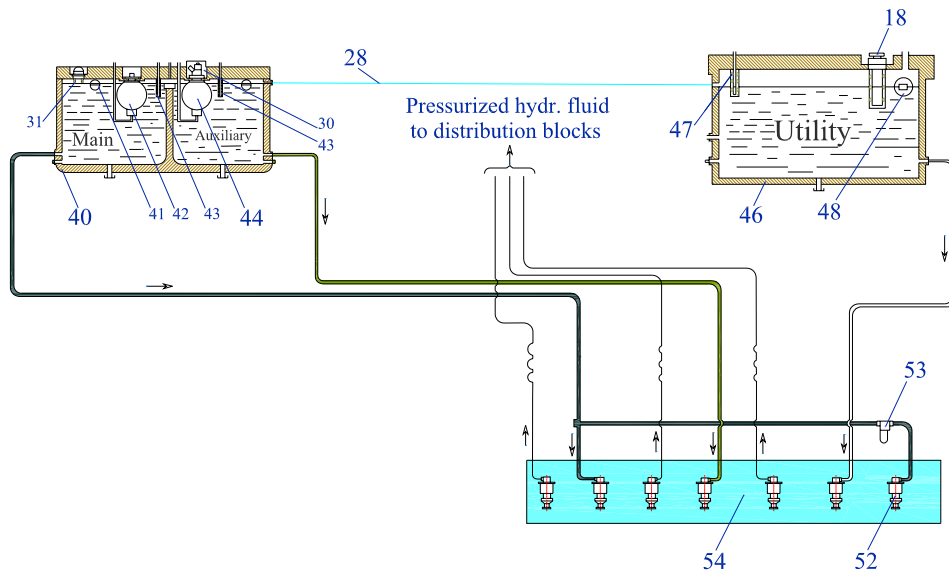

Fig.6.1(a) Existing Ground hydraulic power circuit line of Mi-24 helicopter

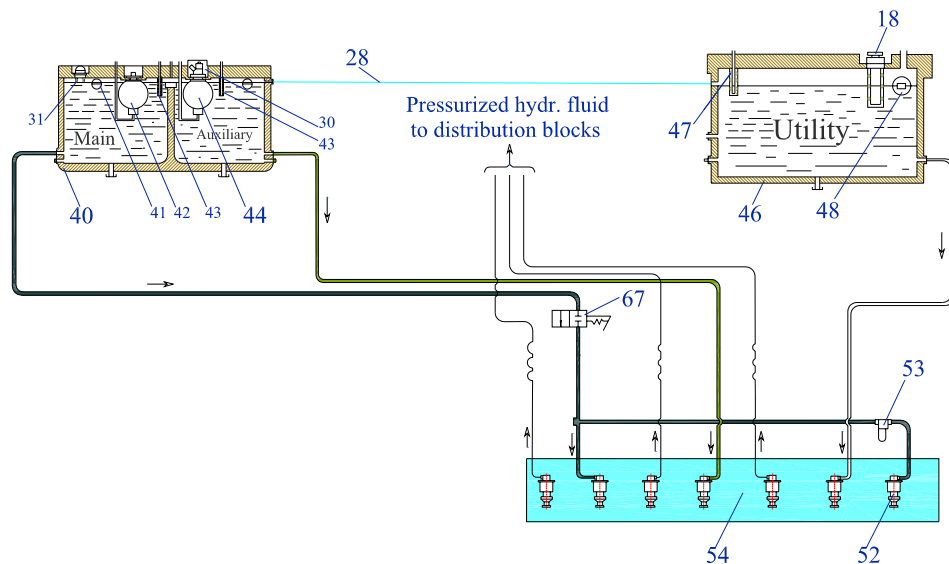
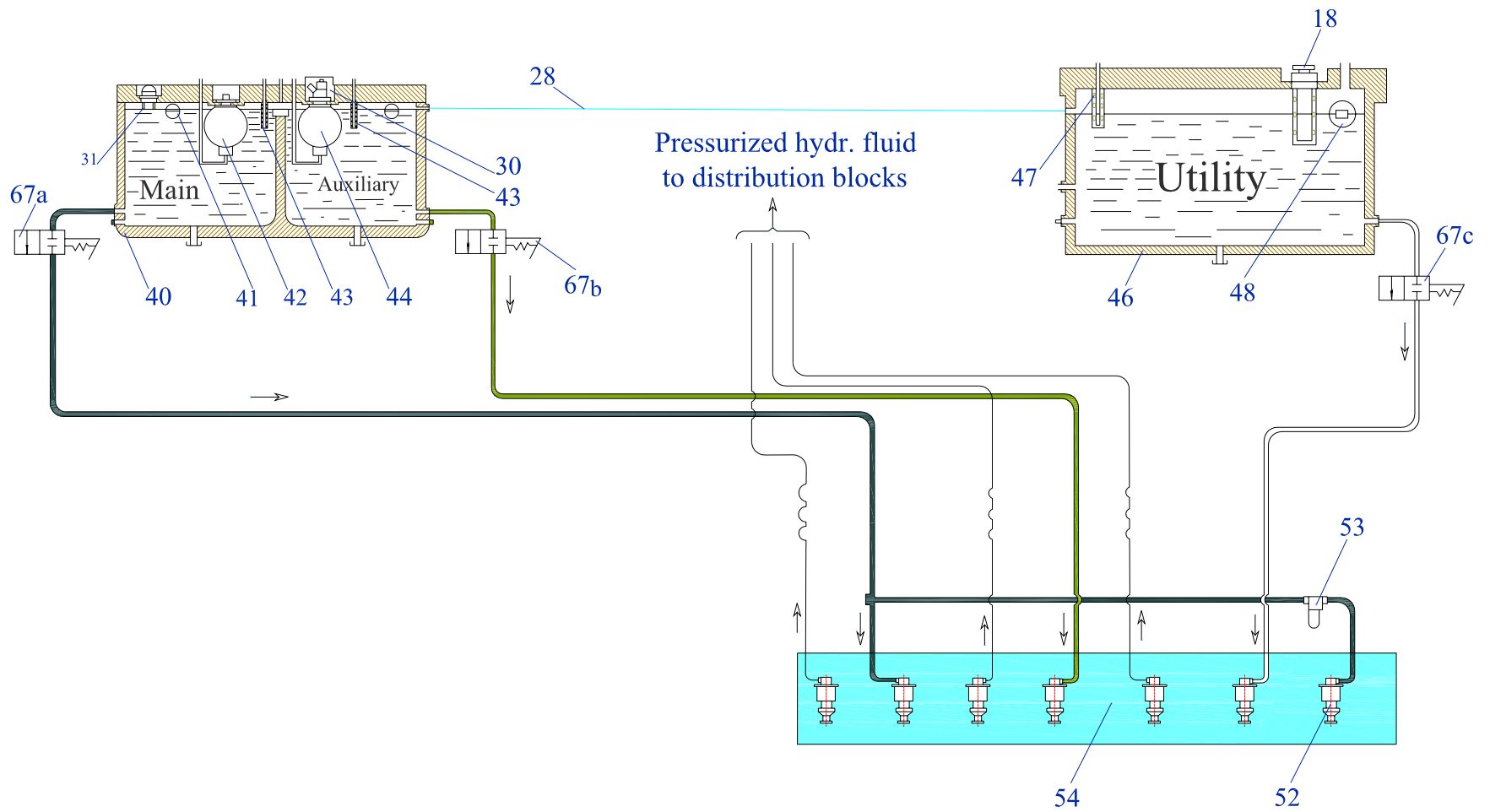

Fig.6.1(b) Existing ground hydraulic power circuit line of Mi-35 helicopter



*Fig.6.1(c) The new modified ground power circuit line of both helicopters*

To install these interchangeable and easily available spring operated cutoff valves, there is a sufficient free space at the bottom of the tanks outlet. And after installing the valves as shown in fig.6.1(c), the operation of checking a ground hydraulic test is done on a jacked helicopter selecting each sub-system separately and giving a pressurized fluid to the inlet of distribution blocks (*AFC-60A and BT-13-1*).

### 6.3.2 Solution Proposed to Get a Standby System for Directional Control Damper and Guiding Device

There has to be another alternative choice to overtake the drop in pressure inside directional control damper so as to control directional motion of the helicopters easily. This can be done by keeping the performance of utility line as much as possible. But, bearing this in mind, another alternative stand-by system is required to satisfy the ‘make-no-mistake principle in flight’. Instead of using or installing another stand alone additional system, it is more preferable to use a simple selector valve to take the required fluid in case of utility line pressure drop. This can be done by taking a fluid from the auxiliary or the main sub-system and connecting it to utility line with the help of simple and interchangeable shuttle valve.

It is more preferable to connect the new installed shuttle valve with the main sub-system rather than the auxiliary line. This is because; as shown from the data collected on crashed helicopters, the impact of loosing directional damping due to utility sub-system failure leads to great disturbance on the pilot to control the helicopter.

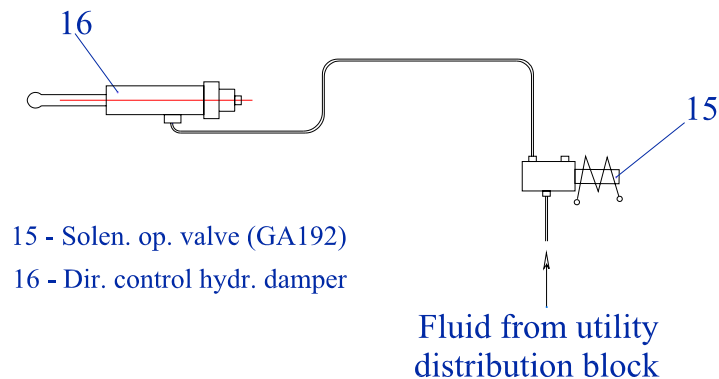

Fig.6.2(a) The present existing directional control damper circuit of both helicopters

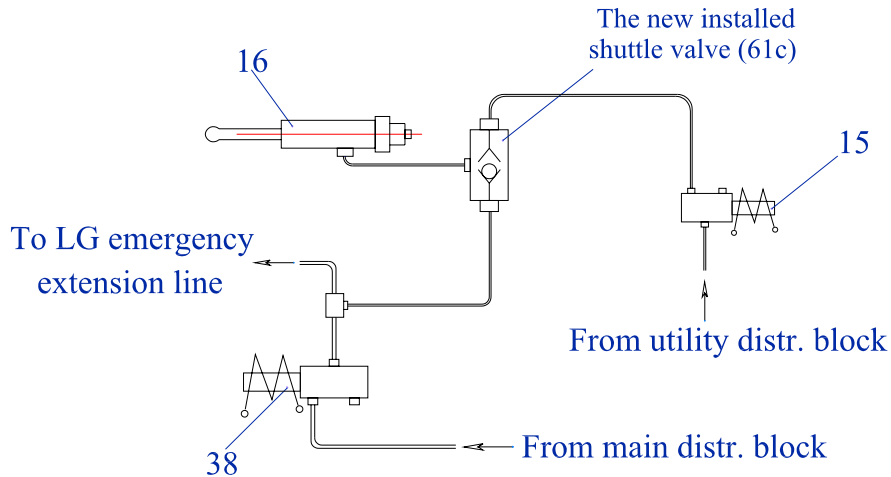

Fig.6.2(b) The new modified directional control damper circuit

During this time, most pilots set the lever arm from the 'MAIN' to 'AUXILIARY' system and try to land the helicopters. If this line is connected to the main system for emergency case, the impact on the pilot will automatically be avoided. As a result of using such connection shown in fig.6.2(b), we can get a safe and easily controlled directional flight.

Also for the guiding device failure due to utility system pressure drop in flight, a fluid supply from either of the main or auxiliary system is required. Since this device is used in some special cases where the helicopter is inside the territory of enemy; using the auxiliary line is more preferable than the main line to connect with the utility system. As can be shown in figure 4.1; when the utility system is operational, the shuttle valve closes the fluid intake from the auxiliary system because of the effect of auxiliary system selection valve(9).

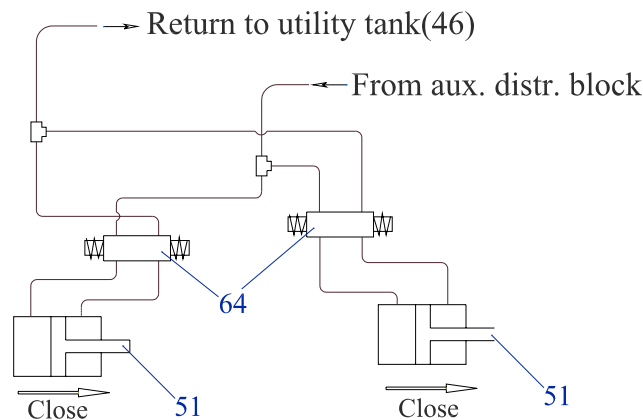
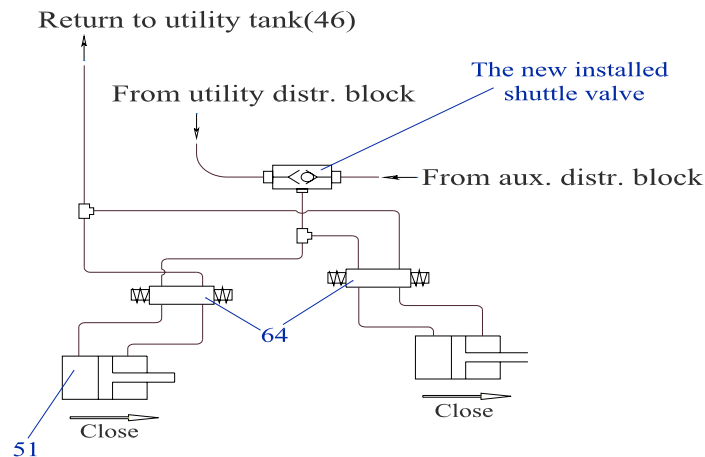

Fig.6.3(a) Existing circuit for operation of guiding device

The new modification on the guiding device operation line that can easily be connected to the auxiliary line to get a backup fluid in case of utility system pressure drop is shown in fig.6.3(b) as follows:



*Fig.6.3(b) The new modified circuit for operation of guiding device*

### **6.3.3 Different Solutions Proposed to Avoid the Effect of Failure on Landing Gear Emergency System**

Numerous methods are employed by designers to extend landing gear in an emergency for different aircraft types. Some systems are as simple as pulling an emergency release handle on the flight deck that disconnects the gear up-locks and allows the gear to literally fall under their own weight to the down-lock position. Other manufacturers of the aircraft hydraulic system prefer to use compressed air to release the up-lock release cylinders. Some aircrafts are so designed that gravity alone will not extend the landing gear. Manufacturers of those aircraft must install a more positive method of landing gear extension using hydraulic fluid or compressed air to provide the required pressure. Probably the most positive method employed utilizes a mechanical hand crank system or a backup hydraulic system with either an auxiliary hand pump or an electrically powered backup hydraulic pump. In this case, different solutions or ideas are presented to improve the safety system in extending the landing gear in case of emergency landing of Mi-24 and Mi-35 helicopters.

In this case; to overtake the pressure drop due to utility sub-system malfunctioning and get a standby safety system, different methods or solutions are proposed and the best among them will later be selected to upgrade the overall hydraulic system of the specified helicopters. Among many alternative solutions, some of the methods primarily proposed as a choice are categorized as follows:

- Using the auxiliary hydraulic sub-system for emergency release;
  - Direct connection to the landing gear system line just as the main hydraulic sub-system works
  - Installing the manual landing gear emergency lever on the auxiliary line
  - Connecting the auxiliary sub-system inline with the utility line at the intake of manual landing gear emergency lever(a modified Mi-35 case).
- Upgrading the main hydraulic sub-system;
  - Connecting the main sub-system inline with the utility line at the intake of manual landing gear emergency lever(again a modified Mi-35 case).
- Installing another alternative systems;
  - Mechanical chain, gear or crank system, etc
  - Pneumatic system, Electrical system (with the help of motor)
  - With the help of gravity
- Direct return of fluid from the landing gear extension line;
  - Direct return of fluid to the main tank through filter (14a) instead of allowing it to return back to the utility tank
  - Direct return of fluid to the auxiliary tank through filter (14b) instead of allowing it to return back to the utility tank
  - Direct return of fluid to the utility tank (in a short way without flowing through the valves, filters, and other parts).

#### **6.4 Evaluation of the concept variants against different criteria for LG Emergency System**

The solution proposals explained before are now firmed up into concept variants that must be evaluated so as to provide the objective of getting a qualified improvement in emergency extension of the specified helicopters.

## Clarification of the Concept Variants for Concept Scoring Decision

### a) Using the Auxiliary Hydraulic Sub-system for Emergency Release

#### *Direct Connection of Auxiliary Line for LG Emergency*

Direct connection of auxiliary sub-system for landing gear emergency release is mainly useful in case of main and utility hydraulic sub-systems failure. In order to use this, we need to install another solenoid operated or selector valve to change from utility operated to the auxiliary operated extension line as the main sub-system does. Due to direct connection with the emergency LG extension line, there will be no access of using the fluid in the utility line and hence efficient utilization of using the whole fluid in the hydraulic system becomes reduced. Because of the absence of manual landing gear emergency lever, this method is more useful for Mi-24 helicopters. But a similar problem faced during emergency landing using the main sub-system may probably happen again.

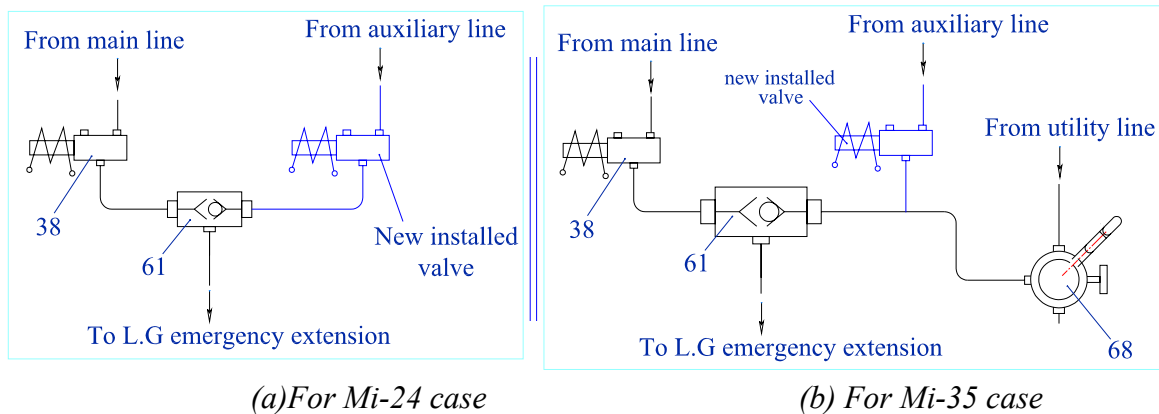
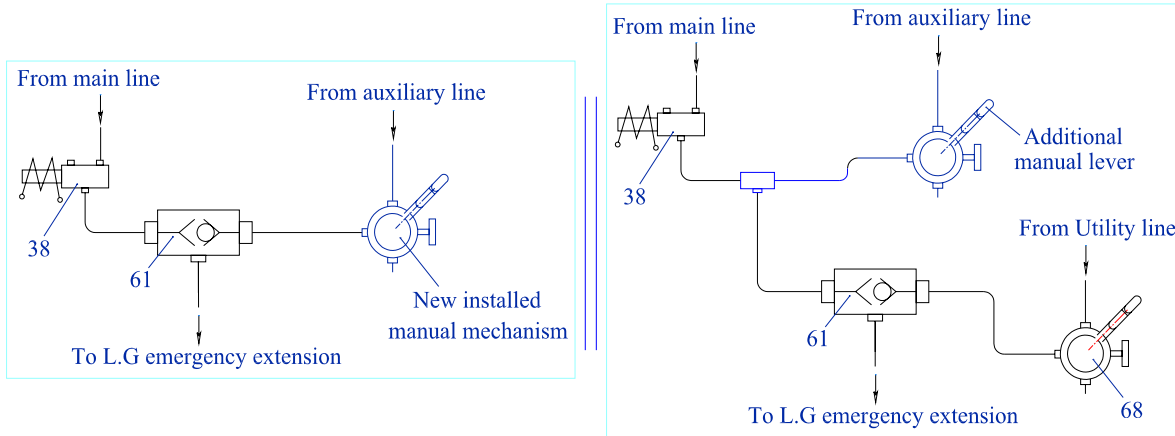

Fig.6.4 Options for showing direct connection of auxiliary line to LG emergency release

#### *Installing Manual LG Emergency Lever on the Auxiliary Line*

The auxiliary hydraulic sub-system totally uses mechanically operated valves and components. Hence this line can work effectively without any impact due to electrical failures. Installing this manually operated emergency release mechanism is also useful in case of pump or engine failure. Due to some modifications on Mi-35 helicopters, the manual landing gear emergency extension lever is installed on the utility line. Hence installing another stand alone installation takes more space or redundancy and unwanted

cost occurs. In addition to this; if the fluid in the auxiliary line drains due to joint disconnection or pipeline damages, we can't efficiently use this manually operated mechanism. This is shown in the figure below.



(a) For Mi-24 case

(b) For Mi-35 case

Fig.6.5 Options showing installation of manual LG emergency lever on auxiliary line

### Connecting both the Auxiliary and Utility Lines for Input to Manual Lever

In rationalizing the improved landing gear emergency system of Mi-35 helicopters, when the manual emergency extension lever uses a fluid either from the utility or auxiliary line, we can extend the leg in case of a failure or drain on either of the two sub-systems. Hence, feeding the hydraulic input to the manually operated valve with both the utility and auxiliary line makes it a sustainable standby alternative system for the problem explained above. Since the manual emergency extension mechanism is already installed on the utility line of Mi-35 helicopters, connecting this line with fluid from the auxiliary sub-system reduces the cost of installation. Also to get an ease and successful installation of this manual system on Mi-24 helicopters, it is preferable to analyze and use the already

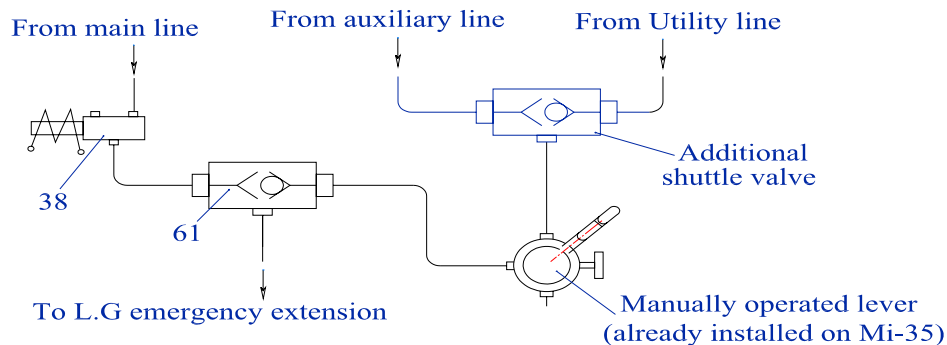

Fig.6.6 Connection of both the auxiliary and utility lines for input to manual lever

installed modular components of Mi-35 helicopters. Keeping every advantage of using this method in mind, we can compare it with the next solution proposals in the concept scoring evaluation method. And this way of connecting the auxiliary sub-system in conjunction with the utility line is explained in Fig.6.6 above.

### b) Upgrading the main hydraulic sub-system

The main sub-system can also be used as a standby system of landing gear extension incase of utility system failure. This process is performed by activating the solenoid operated  $\Gamma$ A-165 valve. If this  $\Gamma$ A-165 valve doesn't function because of electrical system failure, the pilot couldn't control or extend the leg to land the helicopter without damage. When both the main and utility sub-system couldn't function incase of electrically operated solenoid valves failure, we need to have a manual operated system. To avoid the risk of this; the manual landing gear emergency extension mechanism is already installed on Mi-35 helicopters utility line. If we connect the input fluid to this manual mechanism additionally with the main line, the landing gear can be extended taking the fluid from the main line even if the fluid in the utility line drains or flow out of the sub-system. But, having an emergency landing gear line on this main sub-system can be a redundancy and increase in function performed by the main movement of the helicopter in flight control.

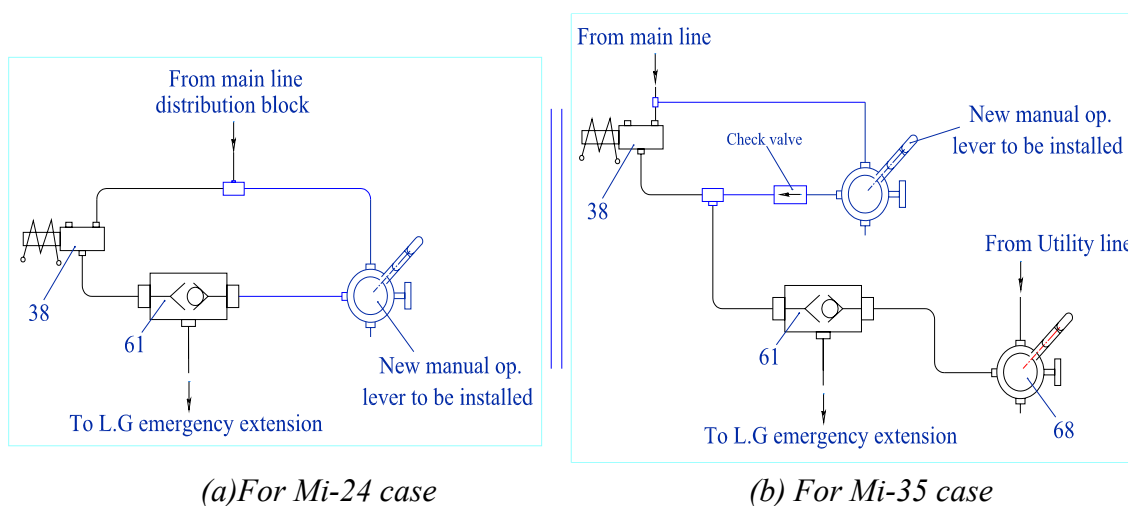

Fig.6.7 Options showing upgrading the main hydraulic sub-system

### **c) Installing Different Alternative Systems**

#### ***Pneumatic System***

With the help of pneumatic system, we can use a compressed air from the brake system line to release the uplock release cylinders. But we also need to release actuating cylinder of the landing gear and then lock after full extension of the leg. To do this; additional pneumatic power source (nitrogen bottle) is required to use the existing pneumatic system for emergency release of landing gear in the specified helicopters. In addition to this, the other pneumatic pipe line fitting in the existing helicopters has to be analyzed to check whether it can withstand (overcome) the added pressure or not.

#### ***Electrical System (with the help of motor)***

We can use this means of mechanism efficiently incase of hydraulic system failure on utility and main lines. In using this method, there is no need of requiring a hydraulic fluid which inturn free from fluid contamination, pressure drop, leakage and other related problems. The other advantage of using electrical means could give a very fast action incase of fast emergency requirement for the pilots action or decision. But in using this method, there is no enough or sufficient space in the helicopters configuration to install a motor, and also it requires additional chain or mechanism to change from hydraulic operated system to the new required extending means of the landing gear.

#### ***Mechanical chain, gear or crank system***

In using a gear and other mechanical linkage, there is no need of requiring a hydraulic fluid that makes this method to be of trouble free from hydraulic related problems. Also this method is more economical when we use modular and simple mechanisms for releasing and locking the uplocks rather than for releasing the extension legs in the existing helicopters configuration. But it is comparatively less reliable and takes more lag time between the pilot's action to control the helicopter and the response from the components in the mechanism than using a hydraulic means.

#### ***With the help of gravity***

In using the help of gravity there is no additional power requirement to release the landing gear. Because of this advantage such a means of extending the landing gear is

more economical. Also the lower the speed of the helicopters has another advantage on the impact of inertia applied on the leg to be released down. But in case of Mi-24 and Mi-35 helicopters design, the door locks should be released first before the leg is extended by its own weight. Moreover, if something locks at the linkage where the leg is jointed to the lower main frame of the helicopter, effectiveness of using self release by its own weight becomes less.

#### **d) Direct Return of Fluid from the Landing Gear Extension Line**

Direct return of fluid back to the hydraulic tank can reduce the probability of complete outflow of fluid in case of damage on the landing gear return line. According to the hydraulic related accident investigation data collected on some crushed helicopters, the utility tank had been empty because of failure on the return line of landing gear extension line. Such a condition can be reduced by direct shortway return of fluid back to the tank, but the returned fluid requires filtration before it enters the utility tank. A better way for improving this problem can be made by attaining a proper maintenance and improvements in the overall circuit line.

### **6.4.1 Concept Scoring**

Now the basic evaluation of three best selected solutions are firmed up considering ease of maintenance and installation, material availability, economic consideration, effectiveness, use value analysis, fail-safe analysis and other technical criteria.

To evaluate the corresponding weight and relative ratings; different questionnaires have been given to some selected technicians from the hydraulic shop in Dejen Aviation Maintenance and Engineering Complex, and Ethiopian Airforce helicopter maintenance center. A combined method of brain storming and delphi method has also been collected at different sites. Finally all the concepts of evaluation for different proposed solutions are reviewed and presented in the form of the next concept scoring table as follows:

*Meaning of relative rating was as follows:*

- 4 = Very good/ High*
- 3 = Good / Moderate*
- 2 = Fair*
- 1 = Lower*

Table 6.1 Concept scoring table

| Selected criteria  | Weight | Solutions (Concept variant)    |                |  |                |  |                |
|--|--------|--------------------------------|----------------|--|----------------|--|----------------|
|  |        | Using the auxiliary sub-system |                | Upgrading the main sub-system            |                | Different alternative systems (Mech. chain and Motor,... ) |                |
|  |        | Relative rating                | Weighted score | Relative rating                          | Weighted score | Relative rating  | Weighted score |
| Ease of maintenance  | 20%    | 4                              | 0.80           | 4  | 0.80           | 2  | 0.40           |
| Material availability  | 15%    | 3                              | 0.45           | 3  | 0.45           | 4  | 0.60           |
| Cost of materials required (pipes, valves, ...)  | 10%    | 3                              | 0.30           | 3  | 0.30           | 3  | 0.30           |
| Space availability for ease of installation  | 20%    | 4                              | 0.80           | 3  | 0.60           | 2  | 0.40           |
| Effectiveness (Utilization incase of fail-safe & damage tolerance considering distance, complexities, ...) | 30%    | 3                              | 0.90           | 2  | 0.60           | 1  | 0.30           |
| Others (Backup response to failures, modularity of components, ...)  | 10%    | 4                              | 0.40           | 2  | 0.20           | 1  | 0.10           |
| Total Score  |        | 3.65                           |                | 2.85                                     |                | 2.10   |                |
| Rank   |        | 1                              |                | 2  |                | 3  |                |
| Decision to continue or not  |        | Develop                        |                | No                                       |                | No   |                |
| Remark   |        | Reference for further analysis |                | Can be taken as a 2 <sup>nd</sup> choice |                | Low in effectiveness and others                            |                |

## 6.5 Concept Review and Technical Detail of the Selected Solution

### 6.5.1 Concept Review on Selected Solution

In section 6.4, various proposed solutions are evaluated from the point of their own advantages and disadvantages. Among these concept variants the main three best concept variants are selected and ranked using the concept scoring method. The first selected method for extending the landing gear extension method is to use the auxiliary sub-system by taking a fluid for standby alternative backup to the manually operated mechanism already installed on Mi-35 helicopters utility line. Using this selected proposal, any interested researcher can go for further detail analysis after getting sufficient input datas from the manufacturing company.

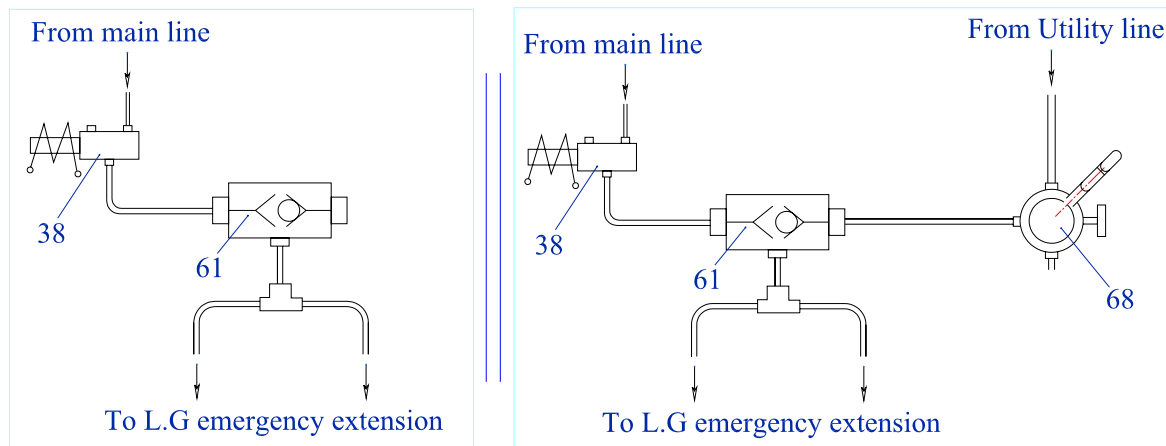

(a) Distribution line for Mi-24

(b) Distribution line for Mi-35

Fig.6.8(a, b) Present LG emergency extension distribution line in the existing helicopters

As shown in fig. 6.8(a); for landing gear emergency extension system a fluid entered in to the shuttle valve (61) from the main line only. This is modified in fig. 6.8(b) to avoid lack of fluid entering to the shuttle valve for the case of solenoid operated  $\Gamma$ A-165 valve malfunction or main sub-system failure to feed the fluid.

Now for more effective and reliable feeding of fluid to the common manually operated valve, we can use the auxiliary line by installing only a single additional shuttle valve (61b) and pipeline with minimum cost of installation as shown in fig. 6.8(c) as follows:

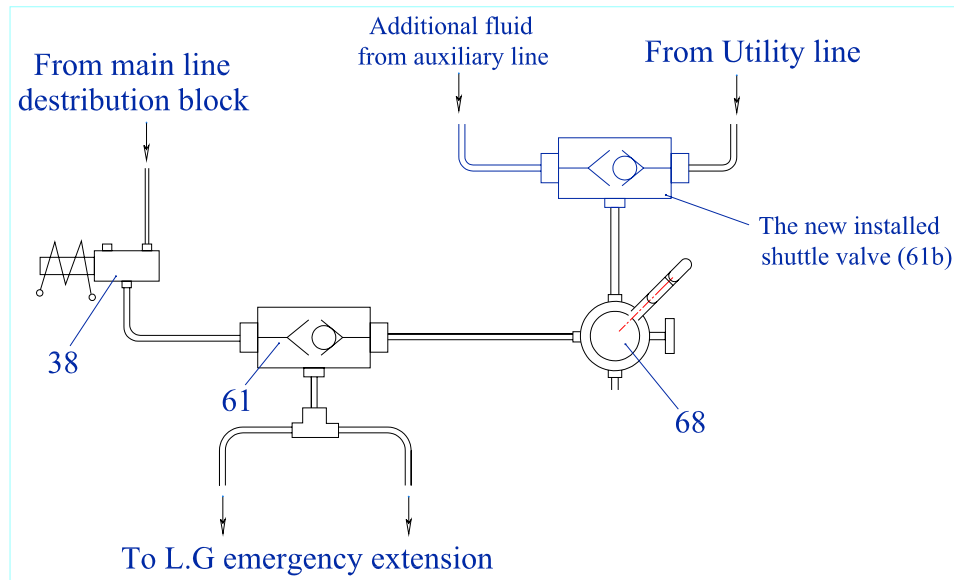

*Fig.6.8(c) Modified LG emergency distribution line for both helicopters*

Availability of these added valves for Mi-35 spare part reduces the cost of installation. Also the space provided for installation of these added parts is shown on Mi-35 helicopters near the cabin/crew in a safe position for easy operation and maintenance control.

## 6.5.2 Technical Detail of the New Installed Components

### Landing Gear Emergency Extension Manual Valve

This mechanism mainly consists of a two position control steel valve without the neutral position. As shown in Fig 6.9; connection (I) communicates with the pressure line from either of the utility or auxiliary sub-system through the new installed shuttle valve (61b), while connection (II) communicates with the landing gear emergency extension shuttle valve (61) through a pipe, and connection (III) communicates with the return line.

In the initial position, connection (I) is closed and connection (II) communicates with connection (III). With handle (1) set to DOWN (ВБИЦУСК) position, control valve (4) turns to communicate connection (I) chamber with that of connection (II). In this position, pressurized hydraulic fluid comes from connection (I), through connection (II) to the shuttle valve (61) and further to the landing gear extension line. And ball (2) with spring (3) serve for locking the handle.

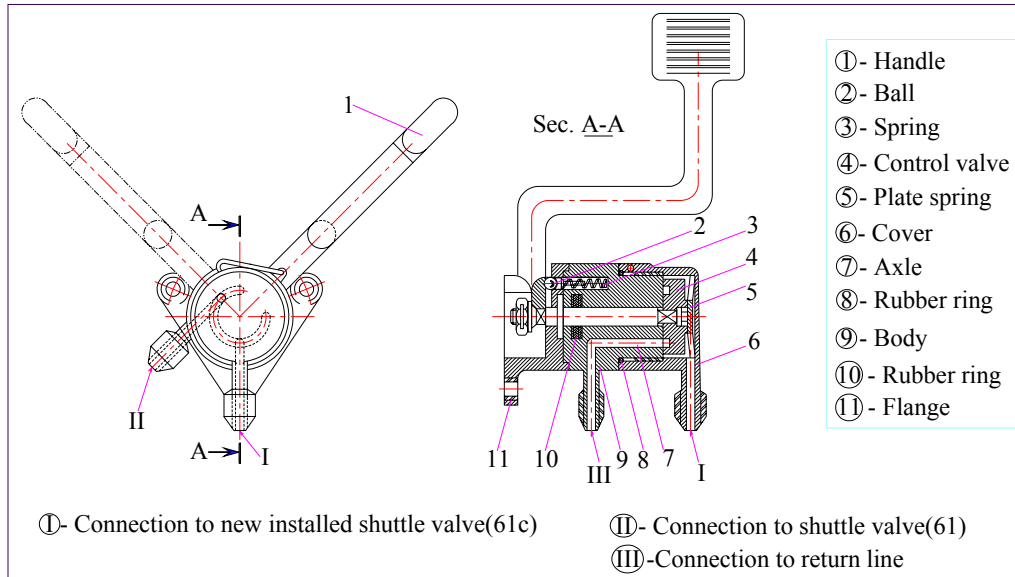

Fig.6.9 Landing gear emergency extension manual valve

### YF97-7 Shuttle Valve

The new installed shuttle valve (61b) serves for automatic selection of the manual landing gear emergency lever and guidance device operating cylinders from either of the utility or auxiliary hydraulic sub-system depending on the system in operation at a certain moment. Similarly shuttle valve (61c) serves for selecting a pressurized fluid from either of the utility or main sub-system for directional damping control pedal in case of utility line pressure drop. And, detail operation's flow diagram of these automatic self controlled shuttle valves is shown in Fig.6.10 below.

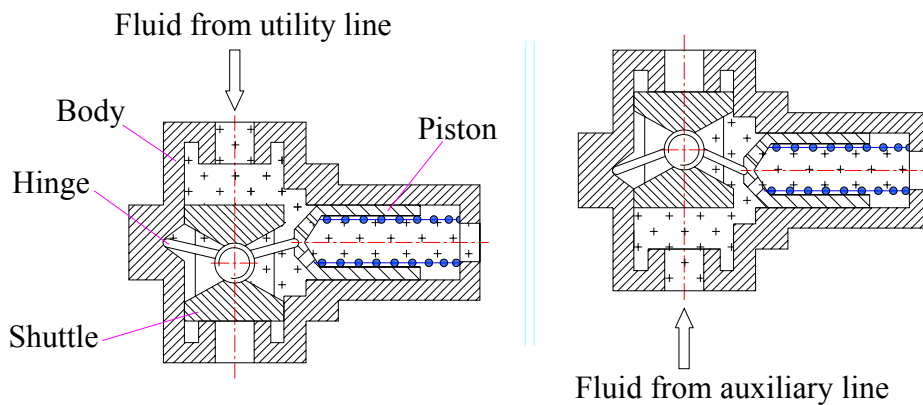

Fig.6.10 Internal flow diagram of shuttle valve(61b)

The hinge abuts the piston to a body sealing bead by shuttle and a spring to cutoff one of the pressure lines. As this takes place, hydraulic fluid from the second pressure line passes freely through the valve. When the pressure is fed from the pressure line having been cutoff, the shuttle shifts to set at the other limit position by the hinge and spring.

## **6.6 Technical Analysis on the Upgraded Overall Hydraulic Circuit**

Now the overall hydraulic circuit shown in fig.4.1(a) and 4.1(b) is revised and improved to avoid the probability of failure due to either of the sub-systems malfunctioning. Keeping the probable causes and suggested solutions in mind, we can also upgrade this existing hydraulic circuit of the specified helicopters as shown in fig.6.11(a) and 6.11(b). In this modified overall hydraulic circuit diagram; the new modified lines are shown in green colored bold lines and cyan shades. Here, the operating principle is similar to the flow procedures explained in section 4.3 except for the new added circuit lines.

For reducing the probability of flow of fluid from the tanks, a spring operated solenoid operated valve can be installed nearby each tank outlet in the space provided besides АГC-60А and БГ-13-1 hydraulic distribution blocks. For safety of the directional control damper, we can use a simple and easily available shuttle valve to use the fluid in the main line for better directional control of the helicopters. In getting this advantage during utility sub-system pressure drop, the pilot can fly and complete the mission in confidence.

The other improvement is taken on the landing gear emergency extension line. This modification is already installed on Mi-35 helicopters except the pressure line of fluid feeding from the auxiliary line. From the past experience in flight of Mi-35 helicopters, this manually operated mechanism is successful in case of utility and main pressure loss due to electrical and other related failures. In conjunction with this line, we can use the fluid coming for landing gear emergency release to operate the guidance device doors for easy self defending process during flight in the enemy territory. The added components are selected from the easily available spares in the overhaul center. Finally, testing of the new installed components can be checked on a jacked-up helicopters and test benches.

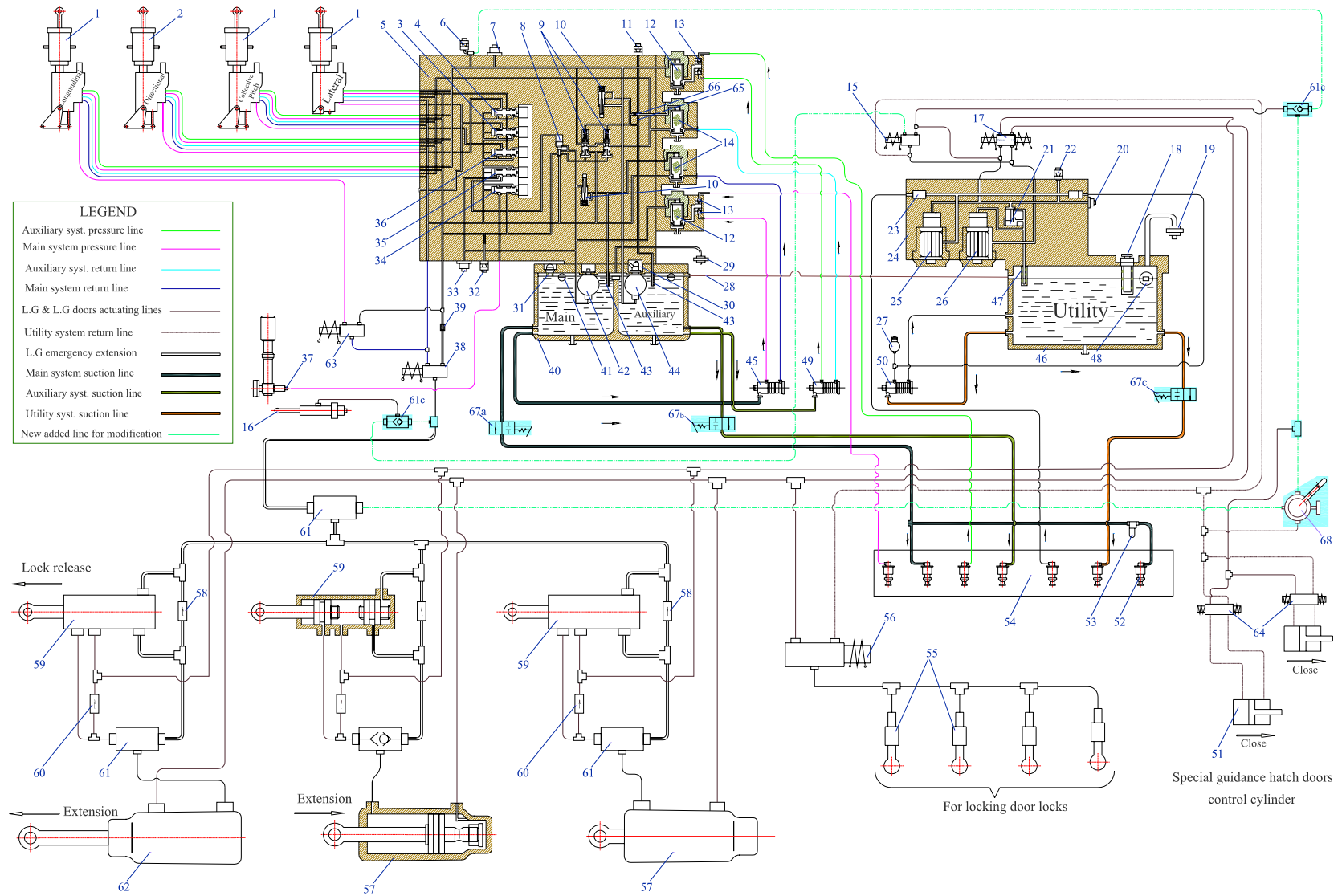

Fig 6.11(a) The new modified overall hydraulic system block diagram for Mi-24 helicopter

**Fig. 6.11(a)**

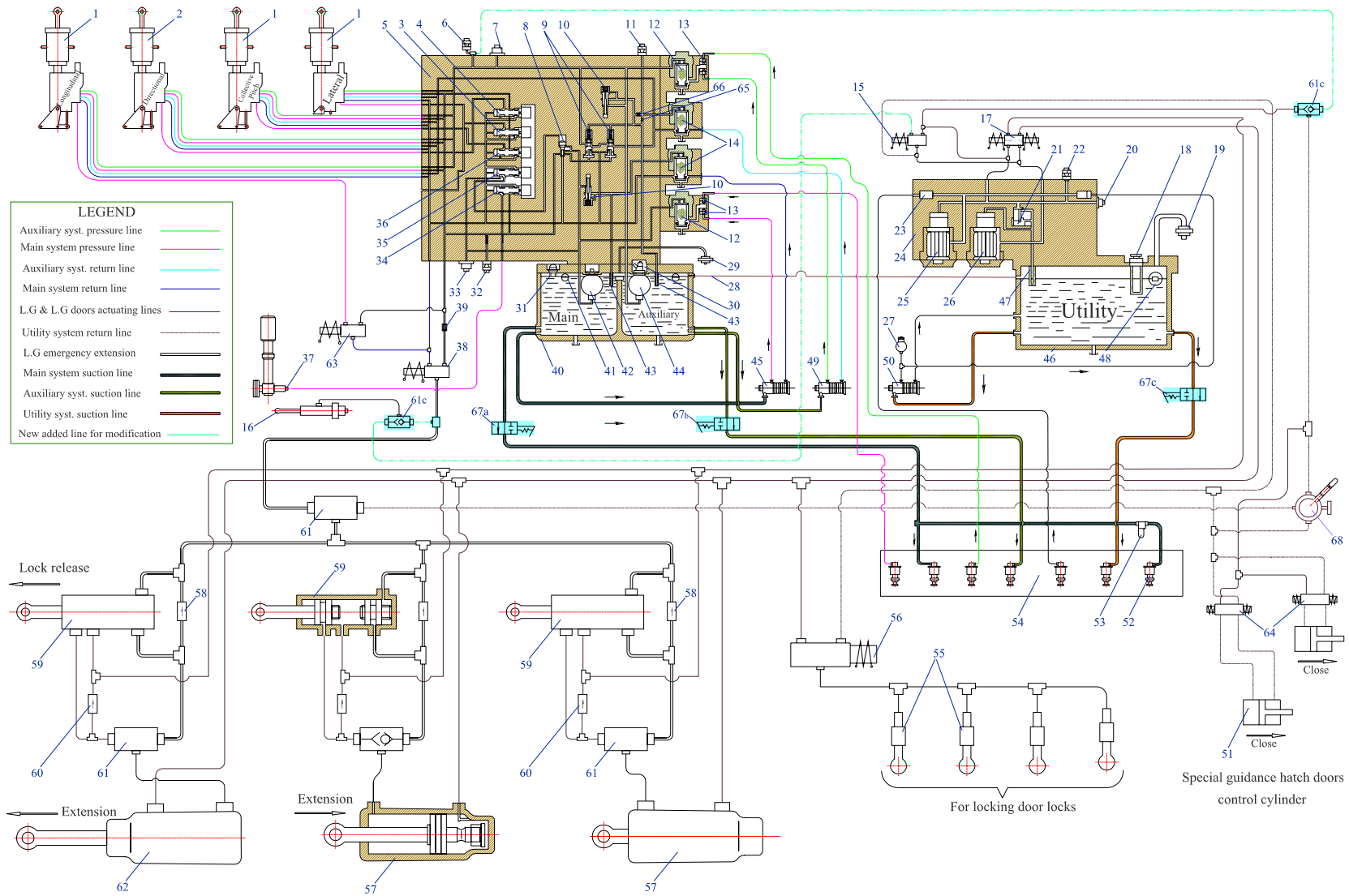

Fig 6.11(b) The new modified overall hydraulic system block diagram for Mi-35 helicopter

**Fig. 6.11(b)**

## Chapter Seven

---

### CONCLUSION AND RECOMMENDATION

#### 7.1 Conclusion

Based on the technical assessment provided, the thesis addresses the current situation of Mi-24 and Mi-35 helicopters hydraulic system. The overall performance of these helicopters indicted that hydraulic related problems are a serious deal to the survival of present technological competition in warfare. And rationalizing the current inhand technology has become the order of the day that defence organizations or countries have to live with. Upgrading the old technology has demanded a detail assessment to go for further analysis. Overall hydraulic circuit of these helicopters has to be improved for avoiding hydraulic related problems.

Currently, Mi-24 helicopters in Ethiopian airforce are almost inoperational or grounded mainly because of hydraulic related problems. Evenif the Mi-35 helicopters are in a good condition to fly, further modification on their overall hydraulic circuit has to be implemented for attaining sustainable safety. The hydraulic power source for both Mi-24 and Mi-35 helicopters are almost similar except some modification added on Mi-35 helicopters. Whereas hydraulic failure documentation of crushed helicopters and lack of further modification on some parts have a great impact on pilots and flight technicians to fly with Mi-24 helicopters.

It has been indicated that some of the main causes for the hydraulic system failure are because of damage on either of the components or pipelines. To overcome such failures on either of the sub-systems, different remedies and modifications have to be considered. Moreover, standby safety circuits are very essential to overtake ones subsystem failure by another.

With continuous follow up on maintenance and inspection on every hydraulic component within the circuit, a better utilization of the helicopters can be achieved. And regardless of the causes for failure; implementing the suggested modifications on the circuit is required for both helicopters.

## **7.2 Recommendation for Further Analysis**

Hydraulic system of both the specified helicopters consists of many components within the three sub-system categories (main, auxiliary and utility). It requires intensive training of technicians, intouched involvement of supervisors and professionals from different field of the helicopter system. A controlled feedback mechanism from the pilots and flight technicians ensure the effective implementation for improving performance of the overall system. Better achievement can also be attained by continuous effort and improvement on the area where repeated failures had been occurred.

Through the establishment of regular repair and maintenance on ground testing machines we can increase the reliability of each component in the overhaul process. Also filling the hydraulic tank must be a primary job of the technician to avoid pressure drop due to hydraulic fluid insufficiency in the system. The other point the technician should consider is that; hydraulic fluid leakage around the engine hot bay may become a fire risk, since AMF-100 oil has a low flashpoint.

In order to protect the hydraulic system piping on the new installed lines against vibration and wear by friction, the way of installation must have provisions for attachment of pipes to the helicopter hull with the aid of special rubberized clothes. Even if the weight of added components is negligible as compared to the payload of helicopters, attention shall be considered for precise and careful weight and balance.

For the next research of detail analysis on each sub-system, we need to have an access to get a detail specification of input parameters to the required circuit line. This can be obtained by developing a means of communication between the specified helicopters manufacturing company and Ethaf., (OR) we need to go for further testing of required samples on test benches and other laboratory test equipment. This study can give a suggestion on the drawbacks of current hydraulic circuit along with some obtained specifications of Mi-24 and Mi-35 helicopters. Hence any interested researcher or the manufacturing company itself can go for further study on the improved or upgraded suggestions and inturn will communicate with customers who owned such helicopters.

## REFERENCES

- [1] W. L. Green, **Aircraft Hydraulic Systems**, A. Wiley Interscience Publication, New York, 1985
- [2] MI-35 Helicopter description, Book II, Airframe and Power plant, Apr.30, 1987
- [3] Lt. Col. Asegid Atnafu, **Hydraulic System modification of Mi-24 Helicopters**, DAMEC, Debrezeit, 2004
- [4] H. G. Conway, **Fluid Pressure Mechanisms**, 2<sup>nd</sup> ed., Sir Isaac Pitman and Son's Ltd., London, 1958
- [5] **MI-24P (MI-25 AND MI-35) Hind Attack / Transport Helicopter:**  
[www.airforce-technology.com/projects/hind/](http://www.airforce-technology.com/projects/hind/)
- [6] Mil **Mi-24** - Wikipedia, the free encyclopedia,  
[www.en.wikipedia.org/wiki/Mil\\_Mi-24](http://www.en.wikipedia.org/wiki/Mil_Mi-24)
- [7] MI-35 Helicopter flight manual, Book I, Apr.30, 1987
- [8] D. S. Kumar, **Fluid mechanics and Fluid Power Engineering**, 6<sup>th</sup> ed., Nai-Sarak, New Delhi: S.K Kataria and Sons, 1998
- [9] Harry L. Stewart, **Practical guide to fluid power**, 1<sup>st</sup> ed., Bombay: D.B. Taraporevala, 1976
- [10] Ernest C. F. JR., **Fluid Power and Control Systems**, Mc Graw-Hill, New York, 1966
- [11] Franklin D. Yeaple, **Hydraulic and Pneumatic Power and Control**, Mc Graw-Hill, New York, 1966
- [12] R. H. Warring, , **Hydraulic Fluids and Engineering Applications**, 1<sup>st</sup> ed., Trade and Tech. Press, 1961

- [13] Vijay Gupta, **Fluid Mechanics and Its Applications**, H.S. Poplai Wiley Eastern Ltd., New Delhi, 1984
- [14] Wayne Johnson , **Helicopter Theory**, Princeton University Press, New York, 1994
- [15] R.W. Prouty, **Helicopter Performance, Stability, and Control**, PWS Publishers, 1995
- [16] Stanley J. Dzik, **Helicopter Design and Data Manual**, J. American Helicopter Society, 1984
- [17] U.S Department of Transportation, **Airframe and Powerplant Mechanics-Airframe Hand Book**, 1<sup>st</sup> ed., Oklahoma, 1976
- [18] R.K Rajput, **Fluid Mechanics and Hydraulic Machines**, 2<sup>nd</sup> ed., S. Chand and Company Ltd., Ram Nagar, New Delhi, 1998