

Addis Ababa
University
(Since 1950)



DESIGN AND ANALYSIS OF THICK PARTITION WALL FOR BUILDING FROM LOCAL COMPOSITE “ENSET” FIBER

By

Ermiyas Sisay

A Thesis Submitted to the School of Graduate Studies of Addis Ababa University in Partial
Fulfillment of the Requirements for the Degree of Masters of Science in Mechanical Engineering
(With Specialization in Applied Mechanics)

Advisor: Prof.Dr.Eyassu Woldesenbet

December 2011

ACKNOWLEDGMENT

First, I would like to express my heartfelt appreciation and gratitude to my thesis advisor Prof. Dr. Eyassu Woldesenbet for his continual encouragement and patient guidance throughout the course of this work. His deep insight into the subject of composite materials and its many applications, his infectious enthusiasm, his patience in helping me learn the basics, and his inexhaustible supply of interesting ideas and materials, have all greatly enriched my experience as a graduate student.

Many thanks are also extended to all my colleagues and friends especially Ato Addis Tesfaye, Gashaw Getenet, Jemal Yesuf, and Yesuf Detemo for their helpful comments and assistance during the research.

At last, but not least, I would like to take this opportunity to thank my father and my mother for all their help and understanding. Without my family's encouragement, love and support, this work would never have been accomplished.

ABSTRACT

Lack of resources and increasing environmental pollution has resulted in great interest of research in materials that are friendly to our health and environment. Polymer composites produced from natural fibers is currently one of the most promising areas in polymer industry. Keeping in view the various advantages of natural fibers, in current series of green composites a study on natural fiber reinforced polymer composites has been made.

This paper presents the results of an experimental series designed to assess the possibility of local “Enset” fiber as reinforcing material for non-load bearing partition wall. First , optimized epoxy resin was reinforced with employing “Enset” fiber of different forms such as traditional woven mat, and long woven fiber form of reinforcement. Second, the new non-load bearing partition wall was designed and manufactured using hand lay-up and vacuum bagging techniques. Then, experiment was conducted on the new proposed composite material. Experimental results of; three point bending test, compressive test and impact test is demonstrated and discussed in this thesis. The experimental results focused on the mechanical properties such as the bending strength, compressive strength and impact resistance of epoxy resin reinforced with “Enset” fiber.

These results suggest that local “Enset” fiber can be potential candidates for use in natural fiber reinforced polymer composites for non-load bearing partition wall.

TABLE OF CONTENT

ACKNOWLEDGMENT	i
ABSTRACT	ii
TABLE OF CONTENT	iii
LIST OF FIGURES	v
LIST OF TABLES	vii
CHAPTER ONE	1
INTRODUCTION	1
1.1 Objective	2
1.2 Research methodology	2
1.3 Thesis organization.....	3
CHAPTER TWO	4
LITRETURE REVIEW	4
2.1 Definition.....	4
2.1.1 Definition of partition wall	4
2.1.2 Definition of composite material	6
2.2 Basic Constituents of Composites.....	7
2.2.1 Matrix.....	7
2.2.2 Reinforcement.....	8
2.3 Mechanical adhesion of reinforcing fiber.....	10
2.3.1 Single fiber Pull-Out test	10
2.3.2 Microbond test	12
2.4 Fire resistant	15
2.5 Sound resistance	16
CHAPTER THREE.....	18
MATERIALS AND FABRICATION	18
3.1 Materials	18
3.1.1 Enset fiber	18
3.1.2 Polyesters Resin.....	22

3.1.3 Hardener (catalyst).....	24
3.1.4 Vacuum bagging material.....	25
3.2 Fabrication.....	35
3.2.1 Hand lay-up technique.....	35
3.2.2 Vacuum bagging technique.....	38
CHAPTER FOUR.....	41
EXPERMENT SET UP.....	41
4.1 Experimental set up for three point bending tests.....	41
4.2 Expermental set up for flat-wise compression test.....	43
4.3 Impact test setup.....	44
CHAPER FIVE.....	46
RESULTS AND DISCUSSION.....	46
5.1 Three point bending.....	46
5.2 Compression test.....	51
5.3 Impact test.....	55
CHAPTER SIX.....	59
CONCLUSIONS AND RECOMMENDATION.....	59
6.1 Conclusions.....	59
6.2 Recommendation.....	59
REFERENCE.....	60

LIST OF FIGURES

Figure 2.1: Two-dimensional drawing for stud framework.....	5
Figure 2.2: Formation of a composite material using fibers and resin [24].....	6
Figure 2.3: Single fiber pull out test [19].....	11
Figure 2.4: Schematic illustration of microbond test [7]	12
Figure 2.5: The modified test rig [7].....	13
Figure 2.6: Wool	17
Figure 3.1: Enset plant	18
Figure 3.2: Enset fiber (kancha).....	19
Figure 3.3: Tradition woven mat (a) Unfinished processing mat (b) Trimmed piece of mat prepared for laminating process	19
Figure 3.4: Special woven mat from bundles of fiber.....	20
Figure 3.5: Enset plant (a) Cross section of Enset plant, (b) Slice of the layer and (c) Extraction of the food and the fiber	21
Figure 3.6: Vacuum bagging system [31].....	25
Figure 3.7: Vacuum pump	26
Figure 3.8: Release fabrics a) Shows the fabric, b) Shows the fabric attachment on the laminate, c) The fabric during the process and d) Shows the fabric when it was removed from the laminate.	27
Figure 3.9: (a) shows the perforated film alone and (b) the perforated film during the attachment over the release fabric.	28
Figure 3.10: Vacuum bag (a) Before, and (b) During the process	29
Figure 3.11: (a) Mastic roll, (b) Mastic attached to the mold and (c) mastic sealant during the process.....	30
Figure 3.12: Vacuum port a) port 1, b) port 2.....	31
Figure 3.13: The vacuum system and the release agent.....	32
Figure 3.14: Glass mold	34
Figure 3.15: A typical schematic diagram for hand lay-up.....	35

Figure 3.16: Sample partition wall, a) Lateral surface, b) Longitudinal cross section	37
Figure 3.17: A typical vacuum bagging lay-up before and after vacuum is applied	38
Figure 3.18: Sample partition walls made using vacuum bagging technique a) product A, b) product B	40
Figure 4.1: Bending specimen.....	41
Figure 4.2: Three point bending set up	42
Figure 4.3: Two dimensional drawing of three point bending.....	43
Figure 4.4: Compression test setup	44
Figure 4.5: 3D view of impact test setup	45
Figure 5.1: Illustration of the tension and compression side of the specimen	46
Figure 5.2: Stress vs. Displacement graph for specimen (NFC01).....	48
Figure 5.3: Stress vs. Displacement graph for specimen (NFC02).....	49
Figure 5.4: Stress vs. Strain graph of specimen (NFC03).....	50
Figure 5.5: Stress vs. Strain graph of specimen (NFC-1)	52
Figure 5.6: Stress vs. Strain graph of specimen (NFC-2)	53
Figure 5.7: Compressive failure (a) specimen (NFC-1), (b) specimen (NFC-2)	54
Figure 5.8: Gypsum board impact damage (a) sample specimen-1, (b) sample specimen-2 and (c) sample specimen-3	55
Figure 5.9: Impact damage (a) sample specimen-11, (b) sample specimen-12, (c) sample specimen-13 And (d) sample specimen-14	56

LIST OF TABLES

Table 3.1: Chemical and Mechanical Properties of resin	22
Table 3.2: Mass of materials used for laminate	23
Table 5.1: Three point bending test result of specimen (NFC01).....	47
Table 5.2: Three point bending test result of specimen (NFC02).....	48
Table 5.3: Three point bending result for a specimen (NFC03)	50
Table 5.4: Average result of the three point bending test	51
Table 5.5: Compression test results of specimen (NFC1).....	51
Table 5.6: Compression test result of specimen (NFC-2).....	53
Table 5.7: Average compression test result of specimen (NFC-2)	53

CHAPTER ONE

INTRODUCTION

The gradual improvement in the standard of living in Ethiopia is leading to the construction of taller buildings. Constructing apartments to replace traditional terraced houses has become a trend. This trend has required a reduction in the construction period, lessening of structural loading, and a reduction in the waste of space and the adoption of lightweight walls. Comparing to either a conventionally reinforced concrete or brick construction, the lightweight walls of high-rise apartments are thinner and lighter.

Lightweight non-load bearing partitions are used in all types of buildings. The actual form of construction will be determined by the specified performance criteria and desired appearance. Fixed stud and panel partitions are normally used in housing, schools and industrial buildings, whereas re-locatable frame and sheet systems are more appropriate for offices and other commercial buildings. Twin-framed constructions of various types are also available, which are used to sub-divide multi-screen cinema complexes and other applications requiring high sound insulation. Therefore light weight non-load bearing partition wall can be potentially made from composite materials.

Composite materials are the most promising materials nowadays. A lot of research has been made all over the world due to composites remarkable mechanical properties. These materials can be used for variety of application. The way composite materials are designed and manufactured, especially their tailor ability, creates advantages in their use. It is therefore possible to design and produce partition wall from composite materials, so that construction materials can be improved through the development and application of composite.

Composite materials are great candidates to replace the tradition materials like mud, wood, metal and concrete which have their own drawbacks such as heavy weight, chemical attack and poor durability. In addition, costly imported partition walls are out of the reach of most people. So the need for another high quality local made material has become an urgent. Therefore a new composite wall made from local natural fiber is proposed in this research.

These composite walls offer advantages in terms of short production time, extended life time, local accessibility of required raw materials and low cost. The proposed material also posses

better mechanical properties such as their high -toughness, superior impact property and ease of reshaping . These proposed composite materials are made from natural fiber.

Natural fiber reinforced composites have advantage over common reinforcing composites such as those using glass and carbon fibers, as they provide low cost, low density, high toughness, acceptable specific strength, enhanced energy recovery, recyclability and biodegradability . They also minimize the adverse impact on the environment.

1.1 Objective

The main objective of the research is:

- To design a wall partition from natural and local fiber materials.

The research has also the following specific objectives, and these are

- To find and develop an appropriate local partition wall material from natural Enset fiber.
- To search and develop effective resin material for Enset natural fiber.
- To develop a material that will resist impact, shear, compressive and bending loads.
- To develop durable, quality and economical product that satisfy the customer interest and needs.
- To add some cultural value on the product
- To make the product lightweight and easy to handle
- To increase load sharing ability of the product

1.2 Research methodology

This study is an experimental investigation of mechanical property of the proposed material for wall partitioning in a building. Some simple numerical analysis is performed. The experiment is conducted based on the set up available in the laboratory and some modifications were made.

Experiment

In this research, experiment is carried out to measure the stability and integrity of the proposed material by the following test:

- Impact test,
- Bending test, and
- Compressive test

Some of the results are compared with gypsum board which is imported from abroad.

1.3 Thesis organization

This paper is organized in-to six chapters. The first chapter contains introduction, objective and research methodology. The second chapter is literature review. In this part a lot of topics are raised related to this study such as definitions, natural fiber- , synthetic fiber, testing fiber and resin adhesion and other related topics. The third chapter discusses the fabrication techniques used for the production of the wall partition, hand lay-up and vacuum bagging. In the fourth chapter, experimental set up for three point bending, flat wise compression and impact tests are described. The fifth chapter provides experimental results and discussion. Finally in the sixth chapter conclusions and recommendation of the paper are provided.

CHAPTER TWO

LITRETURE REVIEW

2.1 Definition

2.1.1 Definition of partition wall

A **partition** is defined in British Standards as an "internal, dividing, non-load bearing, vertical Construction". In European, European Committee for Standardization (CEN) standards it is defined as a non-load bearing wall, and EOTA European Technical Approval Guideline for partitions (ETAG 003), is entitled "Internal partition kits for use as non-load bearing walls". Despite these inconsistencies, the term **partition** as used in this publication, normally relates to a non-load bearing materials. Whilst the primary function of a partition is for space division within a building, it may also be used to separate areas with different floor levels [26].

There are different classification of partition wall depending on the load bearing capability of the material, the material type it used, joint and connection mechanism it had and manufacturing technique used. Among these the load bearing capabilities of a partition classify partition in-to two major categories.

- Load bearing Partition Walls and
- Non-Load bearing Partition Walls

Load bearing Partition Walls – are walls which carry roof and/or upper floor loads in addition to their own self weight and wall lining [17]. Such group of partition wall most of the time are made from concrete and fiber reinforced concrete and other material. These load bearing materials are expected to have strong stability, integrity and stiffness property. And they can be hollow or solid block.

Non-Load bearing Partition Walls -are walls which impart self weight only to supporting structure and some live loads which are temporary loads due to furniture [17]. Most of the time these groups of partition are prepared in sheet form and they are light in weight and easy to handle.

Non-load bearing partition usually attached or connected to either timber stud load carrying structure (framework) or metal stud load carrying structure. The later has a better load carrying

capability and used most of the time in countries like Japan where earthquake are frequent[17]. This light weight non-load bearing partition walls are made from materials like gypsum, Plywood and composite.

Figure 2.1 shows a two-dimensional drawing for house framework.

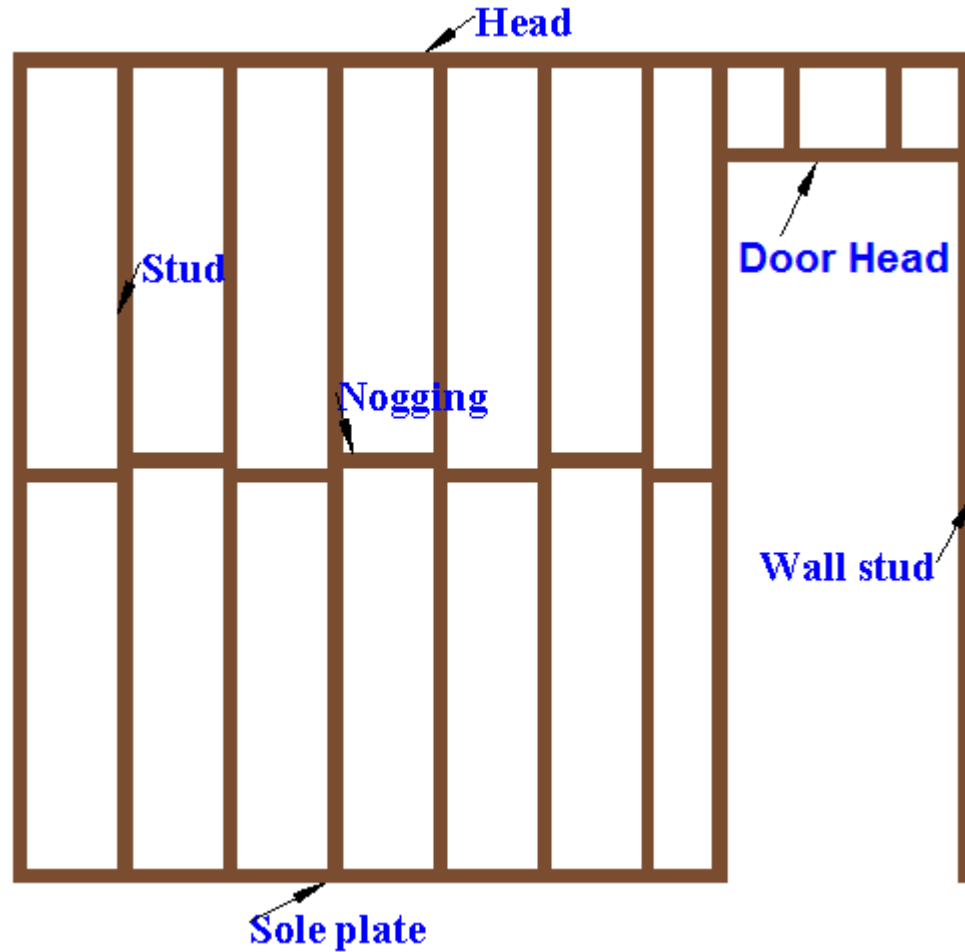

Figure 2.1: Two-dimensional drawing for stud framework

Composite materials are an ideal material for every application. Composite materials have become common engineering materials and are designed and manufactured for various applications including automotive components, sporting goods, aerospace parts, consumer goods, and in the marine and oil industries. The growth in composite usage also came about because of increased awareness regarding product performance and increased competition in the global market for lightweight components. Among all materials, composite materials have the potential to replace widely used steel and aluminum, and many times with better performance. Replacing

steel components with composite components can save 60 to 80% in component weight, and 20 to 50% weight by replacing aluminum parts [24].

Now a days building industries also use composite material for partition wall and panels. As a result material in housing can be improved. So, in this research it's tried to design and manufacture non-loading bearing partition wall from composite materials.

2.1.2 Definition of composite material

According to American society for materials (ASM) Handbook [1], composites can be defined as "a macroscopic combination of two or more distinct material having a recognizable interface between them." [13]. and a composite material is made by combining two or more materials to give a unique combination of properties [24].

Composite materials are flexible materials for multifunctional applications due to their significant properties such as high specific strength, modulus, bending stiffness and chemical resistance [13]. The two basic materials in composite are shown in figure 1.2.

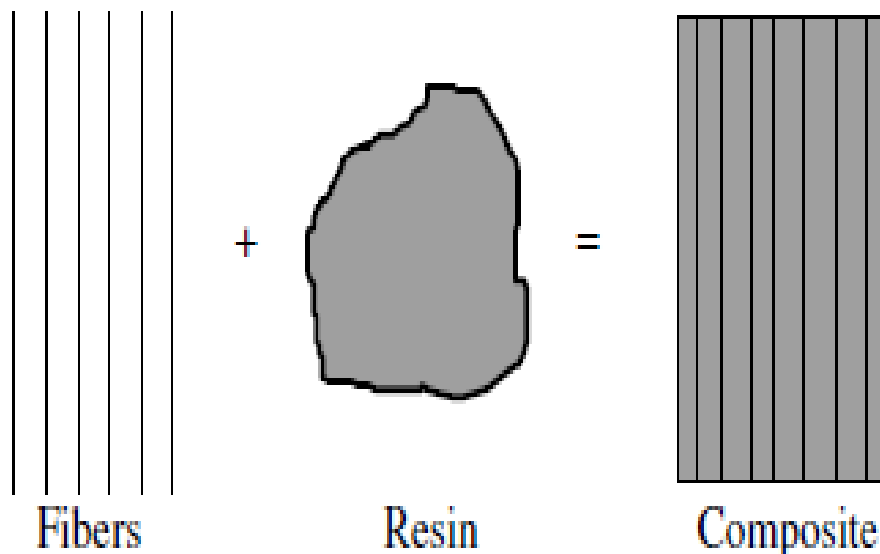

Figure 2.2: Formation of a composite material using fibers and resin [24]

2.2 Basic Constituents of Composites

Composite materials are made of two basic constituents namely, matrix and reinforcement.

2.2.1 Matrix

Matrix is part of the composite material in which it surrounds the fibers and thus protects those fibers against chemical and environmental attacks. For fibers to carry maximum load, the matrix must have a lower modulus and greater elongation than the reinforcement [24].

Matrix is a material which encapsulates two or more than two components in itself. In case of natural fiber reinforced composite material, matrix binds the fibers together. It transfers applied load to these fibers. Various types of materials are generally used as matrix material such as metal matrix, ceramic matrix, carbon graphite matrix, glass matrix and polymer matrix. Among these, polymer matrices are currently being used to a larger extent because of their enormous advantages [29].

Polymer matrix materials include thermosets such as epoxy, phenol and vinyl ester; or thermoplastics such as polyetherketone and polyethersulphone. Metal matrix materials are made by dispersing a reinforcing material into a metal matrix. Polymer matrix composites are used in modern day structural applications due to their significant advantages such as resistance to corrosion, resistance to chemicals, high strength to weight ratio, low thermal and electrical conductivity, and low moisture absorption [13].

The requirements for the matrix in natural fiber reinforced polymer composite are:

- (i) To bind the fibers together, and protect their surfaces from damage during fabrication in the service of life of the composite,
- (ii) Melting point should be lower than the degradation temperature of the fibers,
- (iii) To keep the fibers dispersed and separated so as to avoid any catastrophic propagation of cracks and subsequent failure, to transfer stresses to the fibers efficiently by adhesion and/or friction, when the composite is under load,
- (iv) To be thermally compatible with the reinforcement and
- (v) To be chemically compatible with the fibers over a long period [29].

2.2.2 Reinforcement

Reinforcements are part of composite which provide the strength and stiffness to the composite materials. The reinforcements can be fibers, particulates, or whiskers. The former is very common one. Reinforcing fibers are found in different forms, long continuous fibers, woven fibers and short chopped fibers. Each configuration results in different properties. The properties strongly depend on the way the fibers are laid in the composites materials [24].

Fiber can be classified in to two, based on their source.

a) Synthetic fiber and

b) Natural fiber.

a) Synthetic fiber

Synthetic fibers are fibers which are artificial. The most common synthetic reinforcements are glass, carbon, aramid and boron fibers. Typical fiber diameters range from 5 μ m (0.0002 in.) to 20 μ m (0.0008 in.). The diameter of a glass fiber is in the range of 5 μ to 25 μ m, a carbon fiber is 5 to 8 μ m, an aramid fiber is 12.5 μ m, and a boron fiber is 100 μ m. Because of this thin diameter, the fiber is flexible and easily conforms to various shapes [24].

The most widely used fiber materials in fiber-reinforced plastics (FRP) are glass, carbon, aramid, and boron as stated above. Glass is found in abundance and glass fibers are the cheapest among all other types of fibers. There are three major types of glass fibers: E-glass, S-glass, and S2-glass.

Some of the common types of reinforcements include:

- Continuous carbon tow, glass roving, aramid yarn
- Discontinuous chopped fibers
- Woven fabric
- Multidirectional fabric (stitch bonded for three-dimensional properties)
- Stapled
- Woven or knitted three-dimensional performs

Continuous fibers are used for filament winding, pultrusion, braiding, weaving, and prepregging applications. Continuous fibers are used with most thermoset and thermoplastic resin systems. Chopped fibers are used for making injection molding and compression molding compounds. Chopped fibers are made by cutting the continuous fibers. In spray-up and other processes, continuous fibers are used but are chopped by machine into small pieces before the application. Woven fabrics are used for making preregs as well as for making laminates for a variety of applications (e.g., boating, marine, and sporting). Preforms are made by braiding and other processes and used as reinforcements for RTM (resin transfer molding) and other molding operations [24].

b) Natural Fiber

The interest in natural fiber-reinforced polymer composite materials is rapidly growing both in terms of their industrial applications and fundamental research. They are renewable, cheap, completely or partially recyclable, and biodegradable. Plants, such as flax, cotton, hemp, jute, sisal, kenaf, pineapple, ramie, bamboo, etc., as well as wood, used from time immemorial as a source of lignocelluloses fibers, are more and more often applied as the reinforcement of composites. Their availability, renewability, low density, and price as well as satisfactory mechanical properties make them an attractive ecological alternative to glass, carbon and other man-made fibers used for the manufacturing of composites. The natural fiber-containing composites are more environmentally friendly, and are used in transportation (automobiles, railway coaches, aerospace), military applications, building and construction industries (ceiling paneling, partition boards), packaging, consumer products, etc [10, 12, 20, 21, 27, 28].

As a drawback, natural fibers exhibit low transverse and compressive strength. Natural fibers are also sensitive to environmental factors such as temperature and moisture. Generally, rising moisture content lowers the mechanical properties of a composite. As a result different research has been conducted to increase fiber matrix adhesion through different technique like treating the fiber surface with chemicals [10, 21, 23, and 29].

2.3 Mechanical adhesion of reinforcing fiber

The adhesion between the reinforcing fibers and the matrix in composite materials plays an important role in the final mechanical properties of the materials since the stress transfer between matrix and fibers determines reinforcement efficiency. The mechanical adhesion of reinforcing fibers is usually characterized by the interfacial shear strength (ISS) and it is determined by test methods such as fiber pull-out, microdebond test and fiber fragmentation test [10, 21, 23, 28].

2.3.1 Single fiber Pull-Out test

The Single Fiber Pull-Out test is a commonly used technique to measure interfacial shear strength (IFSS), in which the end of a fiber is embedded in block of matrix that is held as the fiber is pulled out whilst recording load versus displacement to give a "pull-out curve". The Single fiber Pull-Out test offers a number of important practical advantages:

- It is a direct measurement of interfacial strength,
- It requires only small amounts of fiber and matrix, and
- The debonding force can be plotted as a function of displacement and information about the failure process can be gained.

However, the Single Fiber Pull-Out test is based on single fiber specimens and does not reflect the failure process within a composite. As a result, the IFSS value from the pull-out test is considered to give a good indication of interfacial adhesion for natural fiber composites [31].

The tests were carried out by a fiber pull-out apparatus at the Institute for Polymer Research, Dresden, which allows control of the fiber displacement and force measurements as well as data acquisition and handling. The fiber ends were embedded in the polypropylene matrix in a separate micro-oven at a temperature of 200 °C, and the polypropylene droplets were subjected to a heating/cooling rate of 50 °C/min. The free fiber end was then glued to a steel bar that was mounted in a small motor-driven tensile machine [19].

Figure 2.3 shows the principle of a fiber pull-out test from the institute of polymer research, Dresden.

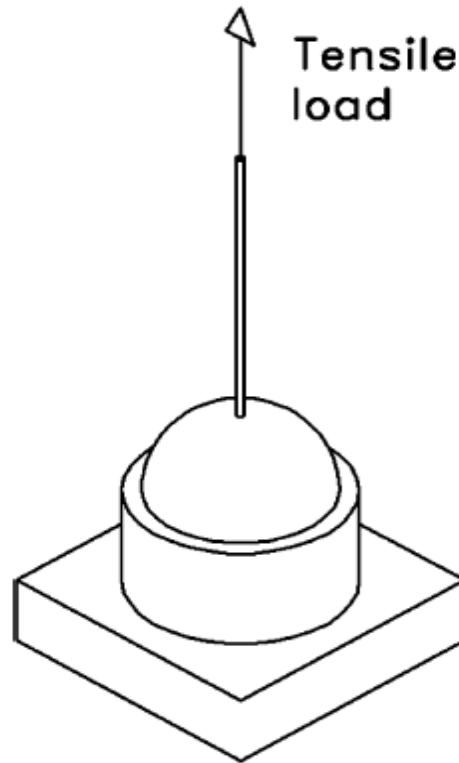

Figure 2.3: Single fiber pull out test [19]

The pull-out test was performed at a cross head displacement rate of 0.2 mm/s. The maximum debonding force and the embedded length was determined from each force displacement curve. The embedding lengths were selected as close as possible to 200 mm [19]. Then the shear strength can be calculated as follow:

$$\tau = \frac{F_d}{D \times \pi \times l_e} \quad 2.1$$

Where

τ : - is the interfacial shear strength

F_d : - is the debonding force

l_e : - is the embedded fiber length and

D : - is the fiber diameter

Based on equation 2.1 it is possible to calculate the interfacial shear strength of the composite materials.

2.3.2 Microbond test

Microbond test is a test where by a polymer matrix droplet is applied on a single reinforcing fiber, which is supported by stripping blades of special equipment; finally the fiber is pulled out from the droplet. In figure 2.4 the schematic representation of Microbond testis is shown.

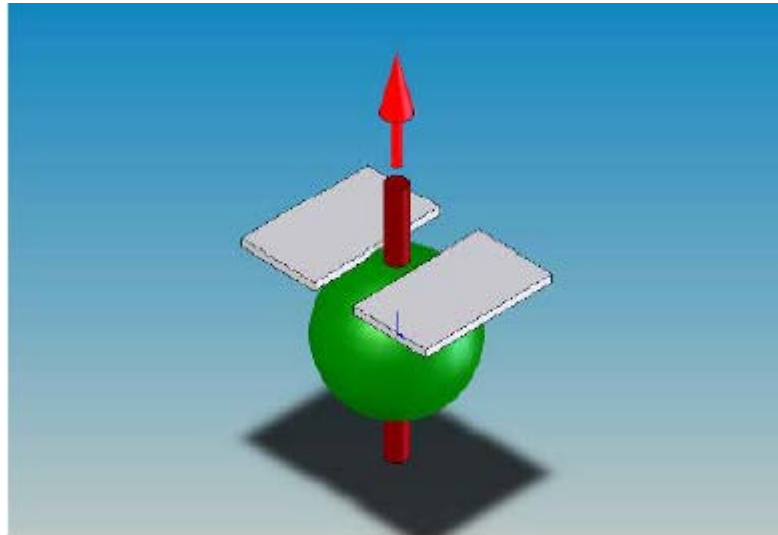

Figure 2.4: Schematic illustration of microbond test [7]

A real practical advantage of the microbond test is that the embedded fiber length can be easily determined, the stress-concentrating effect of the fiber-end can be avoided and owing to the rotational symmetry of the droplet the uniaxial clamping is also provided [6].

The disadvantage of the method is that the droplet shape strongly influences the precision of the test [7]. A further problem is that uncertainties in the position of the supporting points relative to each other and to the fiber strongly influence the reproducibility [8]. The stress distribution within the droplet is characterized by maxima around the supporting points and at the entry point of the fiber into the droplet [7].

Reference [7] presents a new and advanced microbond test by modifying the geometry and the disadvantages described above can be substantially reduced if a more uniform geometry and

stress state can be achieved and consequently the uncertainties of the test and the sensitivity of the method on the testing person can be reduced. In order to achieve these goals the uncertain geometry of the conventional microbond test has been replaced by a matrix cylinder of well reproducible shape and size, which is produced in a metal plate with a drilled hole. The modified microdebond test is shown in the figure below.

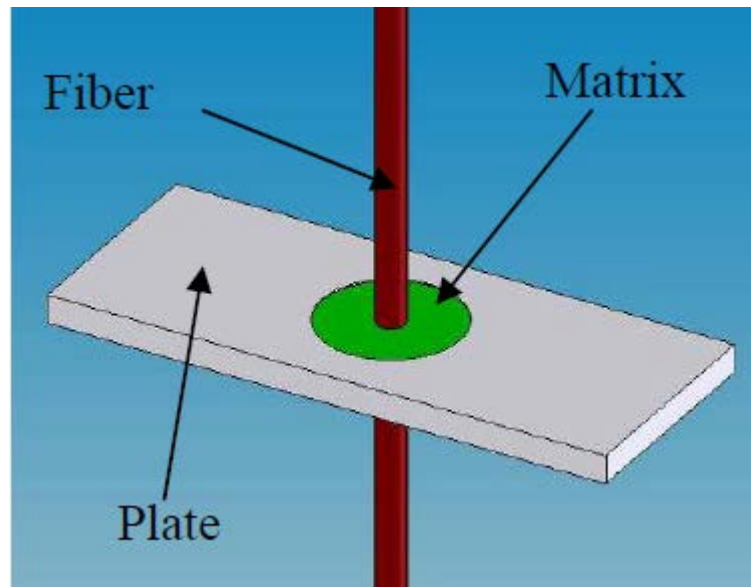

Figure 2.5: The modified test rig [7]

The advantage of the test arrangement is that the stripping blades contact the metal plate, therefore the load is distributed along the cylinder superficies and a uniform shear stress develops. This way one can avoid the elastic, perhaps plastic deformation of the matrix droplets under the blades, thus the formation of stress concentration spots. The test can be performed similarly to the conventional arrangement [7].

Finally Interfacial shear strength can be calculated from the force measured during the microbond tests based on the theory of interfacial shear strength.

$$\tau = \frac{F_{\max}}{D_f \times \pi \times L} \quad 2.2$$

Where:

τ : – is the interfacial shear strength

F_{\max} : - maximum tensile force

D_f : - diameter of the examined fiber and

L : - the length of the fiber part embedded in the matrix

2.3.3 Single fiber fragmentation test

The study of interfacial properties is very essential in order to produce high performance natural fibers composites. Single fiber fragmentation test is an important technique to observe the fiber breaks, fiber flaw spacing and interfacial debonds for evaluating the interface properties of the fiber–matrix composites. Kelly and Tyson [7] reported that single brittle and elastic fibers embedded in plastics will fracture successfully at the flaws positions of fibers when the single fibers composite is strained. Netravali et al. [8] has demonstrated SFFT test on E-glass fibers/epoxy composites. They have successfully measured fragment lengths and interfacial shear strength. Single carbon fiber/epoxy composite was fractured in brittle form during SFFT test which is documented by Varelidis et al. [9] similar studies on SFFT tests were also reported on single glass fibers and carbon fibers/epoxy composites as they fractured in a brittle manner with increasing strain [4].

This test involves the application of increasing axial stress to a specimen containing a single fiber embedded in a polymer matrix. Load is transferred through the matrix into the fiber by means of shear stress at the interface, and fiber failure occurs when this transferred stress reached the tensile strength of the fiber. The fiber will continue to fracture into shorter lengths as the load increases, until the fiber fragments are so small that the tensile stresses induced in the fiber can no longer reach the fiber tensile strength. At this point a state of saturation is reached, and the fragmentation process ceases. Fragment saturation occurs when a state of total fragmentation is reached, and the final fragment length is referred to as the critical fiber length (L_c). Fibers with lengths exceeding L_c will break into two, yielding a random distribution of fragment lengths between $L_c/2$ and L_c , whereas fibers with lengths below L_c will be pulled out of the matrix before fiber failure. It is commonly accepted that L_c is a good indicator of the ability of the

interface to transmit loads between the fiber and matrix, and a decrease in the interfacial adhesion leads to an increase L_c [4].

The interfacial shear strength of the fiber in this method can be calculated as follows

$$\tau = \frac{(\sigma)d}{2 \times L_c} \quad 2.3$$

Where

τ : - is the interfacial shear strength

σ : - is the average fiber strength at critical length of the fiber

d :- is the fiber diameter

L_c : - is the critical length related to the average fiber length at saturation of the fragmentation process

Using the above three methods, it is possible to measure interfacial shear strength of the fiber. But due to lack of some equipment to perform any one of the method mentioned above, the paper was not able to measure the interfacial strength of the proposed natural fiber that is "Enset fiber", however it is also possible to increase the parameter through surface treatment of the fiber.

2.4 Fire resistant

A **fire rated partition** is a partition for which the fire resistance performance has been determined according to the appropriate British or European standards. Similarly, the reaction to fire performance of the exposed surfaces is also determined by the appropriate fire test standards. The requirement to determine the fire resistance and the reaction to fire performance of a partition is not only to save life but also to save the building and other resources. The fire resistance of non-load bearing partitions is evaluated by: BS 476: Part 20:1987: "Method for determination of the fire resistance of elements of construction", which details the general principles of fire resistance testing, and BS 476: Part 22:1987: "Methods for determination of the fire resistance of elements of non-load bearing elements of construction", which details the procedures for testing partitions [26].

The test method measures two criteria of the partition's behavior in the fire test: **insulation** and **Integrity**.

Failure of integrity occurs if:

- the specimen collapses
- sustained flaming is observed on the unexposed face
- a cotton pad can be ignited by hot gases emerging from the specimen
- it is possible to penetrate a gap in the specimen with a 25 mm diameter gauge
- it is possible to penetrate a gap in the specimen with a 6 mm diameter gauge and for it to be traversed for a distance of 150 mm.

Failure of **insulation** occurs if:

- Integrity failure occurs
- The average unexposed face temperature rise as measured by the thermocouples is greater than 140°C.
- The maximum unexposed face temperature rise as measured by any fixed thermocouple and the roving thermocouple is greater than 180°C [26].

The fire resistant test of the proposed material was not conducted due to lack of experimental set-up. However, the fire resistance of the proposed material can be improved using special purpose resin which retards the fire flame expansion. These special purpose resins are made by adding fire retarding material as additive. For this particular case Bismaleimide (BMI) and Polyimide epoxy can be used. It is used for high temperature applications in aircrafts, missiles, and circuit boards. The glass transition temperature of BMIs is in the range of 550 to 600°F, whereas some polyimides offer greater than 700°F [24].

2.5 Sound resistance

The trend to light weight partition walls within commercial and domestic constructions raises interest in a little-studied type of intruding noise, noise generated by wall impacts and transmitted to the receiving space. This light weight partition need to be evaluated the sound performance through well organized equipment. This is because these materials are relatively worse than that of both reinforced concrete and brick [15, 18, 30].

In order to evaluate the insulation performance of a lightweight wall some relevant standards are required. International standards for measuring the insulation of floors to impact sound in the laboratory, such as ISO 140/part 6, BS, 2750/part 6 and ASTM 492, have already been

established. The international standards for field measurement of impact sound insulation of floors and walls. Such as ISO 140/part 7, BS 2750/ part 7, RS A1418 and CNS 8464 A3142, have also been established.

But there are still no standards for laboratory measurement of impact sound of a lightweight wall. For this reason, in this research, sound insulation performance of the proposed material was not performed.

However, to control the interior noise, double-wall structures are widely used in mobile vehicles, partition walls in building and aircraft fuselage shells thanks to their superior noise insulation performance over single-leaf structures. This performance, however, deteriorates at low-frequencies due to the resonances of the air gap between the two walls. A lot of research has been made to create a means to reduce the sound transmission loss and the way to control it [15].

There is a special material to enhance sound insulation performance like wool which is a non-combustible glass mineral for sound insulation in partitions, walls and floors.



Figure 2.6: Wool

The other important point to control sound transmission loss is to seal every opening in the wall using sealant especially around the corner, electrical apparatus and other part of the wall.

CHAPTER THREE

MATERIALS AND FABRICATION

3.1 Materials

3.1.1 Enset fiber

In composite material one of the main components is the reinforcement material that is fiber. So Enset fiber is a natural fiber which is extracted from local Enset plants. Enset is farmed in a mixed system along with grain crops, coffee and others. It is a fascinating plant, related to and resembling the banana tree, but taller, thicker and with no bananas (which gives rise to its English language name “the false banana”) tree. This plant is main source of food in the southern region of Ethiopia especially the” Guarage” people. One of the well known foods is “kocho”, a solid staple a bit like heavy bread, which is eaten with milk, cheese, cabbage, meat and/or coffee. This plant is also a major source fiber, the people call the fiber as “kancha”. They use it to make rope and a mat.

The fiber obtained from this plant has whitish in color, in average 1 m to 1.50 m long and it is a strong fiber. In this paper the Enset fiber was used as reinforcement. In the figure below the Enset plant is shown.



Figure 3.1: Enset plant

Using Enset fiber and the other part of the Enset plant, the Guarage people prepare mats for different purpose depending on the size of the mat. Most of the time the mat is used to décor their house specially the floor. This woven material is strong and costs less in price. As a result this woven material was selected to reinforce the partition wall for a building and it is shown in figure 3.3. In the figure below the Enset fiber is shown.



Figure 3.2: Enset fiber (kancha)



(a)



(b)

Figure 3.3: Tradition woven mat (a) Unfinished processing mat (b) Trimmed piece of mat prepared for laminating process

There is another special woven material which is prepared in the laboratory and it is made from pure Enset fiber manually. The material is prepared from bundles of fiber, then woven each other to make a mat like material. This material was made to prepare test specimen for bending and compression test. The material is shown in figure3.4.

Since the material was prepared manually there is some imperfection in determining the size of the bundles of the fiber and the spacing between them. This would result in heterogeneous property of the final material.



Figure 3.4: Special woven mat from bundles of fiber

Extraction process of Enset fiber

The extraction of the fiber was not taken place as the main objective. Rather the fiber as a byproduct. The main reason for extraction process is searching food. The process is discussed as follows according to the observation made.

- Cut the Enset plant which is ready for the process, from the ground level.
- Cut the outer two layers of the plant into smaller pieces.
- Attach the smaller piece on an inclined plane wood and hold it with right leg.
- Between the right leg and the inclined plane wood scrap it with a tool made from wood to squeeze the size.

- The one which is left on the inclined plane will be the fiber and the one which is left on the ground will be the food.

In the figure below the cross section of the Enset plant and the extraction process of the food is shown.



(a)

(b)



(c)

Figure 3.5: Enset plant (a) Cross section of Enset plant, (b) Slice of the layer and (c) Extraction of the food and the fiber

3.1.2 Polyesters Resin

The resin used for this study is Unsaturated Polyester with brand name of TOPAZ – 2100 AT manufactured by **Industrial Chemicals and Resins Co. Ltd.** TOPAZ – 2100 AT is a medium viscosity thixotropic unsaturated polyester resin based on Isophthalic Acid. It exhibits good mechanical and electrical properties together with good chemical resistance compared to general purpose resins. It has superior chemical resistance towards most mineral and organic acids, solvents and oils. Typical properties of the resin are shown on the table below:

Table 3.1: Chemical and Mechanical Properties of resin

Appearance	Pinkish Viscous Liquid
Viscosity @ 25oc (PaS)	0.45-0.55
Specific Gravity @ 25oc	1.10
Acid Value (Mg KOH/gm)	< 16
Volatile Content (%)	38-42
Tensile Strength (N/mm2)	60
Flexural Strength (N/mm2)	100-110
Heat Distortion Temperature (°C)	85 - 87

All the above information is based on the result of the test carried out at the manufacturer laboratories.

A polyester resin has the following benefits:

- Low cost,
- Good handling characteristics,
- Low viscosity and versatility,

- Good mechanical strength,
- Good electrical properties,
- Good heat resistance,
- Cold and hot molding,
- Flame resistant with fire proof additive, and
- Curing temperature is 120°C (250°F).

Quantity of resin required

The ratio of the resin to the laminate can be determined through experience. It may be based on the volume ratio or mass ratio. But for this study the ratio was made on the base of their mass. The laminate has three layers. The first layer is decorated cotton, the second traditional woven mat, and the third one is 300g fiber glass. The mass is measured using an electronic balance including the matrix. Based on the balance the following reading was obtained and it is shown in the table below.

Table 3.2: Mass of materials used for laminate

No	Material type	Mass reading (g)
1	Decorated cotton	44.5
2	Traditionally woven mat	189.7
3	Fiberglass	75.2
4	Polyester resin	497.6

Based on the above measurement, the mass of the laminate will be the sum of the three layers:

The mass of the laminate = $44.5+189.7+75.2=309.5\text{g}$

The mass of the resin= 497.6g

Therefore the ratio will be = 1.6

This means for every gram of the laminate, 1.6 grams of resin is required. To prepare a sample of partition wall with a size of 420mm long; 400mm wide and 5mm thickness, a resin of 497.6g and a laminate of 309.5g were used.

Such rough calculation can be made to prepare any size of the partition wall required.

3.1.3 Hardener (catalyst)

Polyester resin is cured by adding a catalyst, which causes a chemical reaction without changing its own composition. The catalyst initiates the chemical reaction of the unsaturated polyester and monomer ingredient from liquid to a solid state. When used as a curing agent, catalysts are referred to as catalytic hardeners. Proper care is required to be taken while handling the catalysts as they can cause skin burning and permanent eye damage.

The curing agent applied for the liquid resin is Hardener with brand name of BUTANOX M-50 Manufactured by AKZO NOBEL Company. The product is expected with a Density of 1180 Kg/m³ and Viscosity is 24×10^{-3} Pa.S at a temperature of 20°C. The hardener is soluble in Phthalate but insoluble in water. The chemical nomenclature of the hardener is Methyl Ethyl Ketone peroxide in Dimethyl Phthalate.

It is common to use the ratio of catalyst to resin between 2% - 5% based on their mass. Most of the time the ratio depends on the weather condition and it is also known that too much catalyst usually result in brittle material so care should be taken. But in this study 2% was used as the ratio between catalysts to resin. And the mixture is stirred for two or more minutes using rod like material

3.1.4 Vacuum bagging material

The vacuum bagging system consists of the airtight clamping envelope which is a method for removing air from the envelope until the epoxy adhesive cures. This section discusses some components of this system; it is shown in the figure 3.6, which is used by this paper that is commonly needed materials.

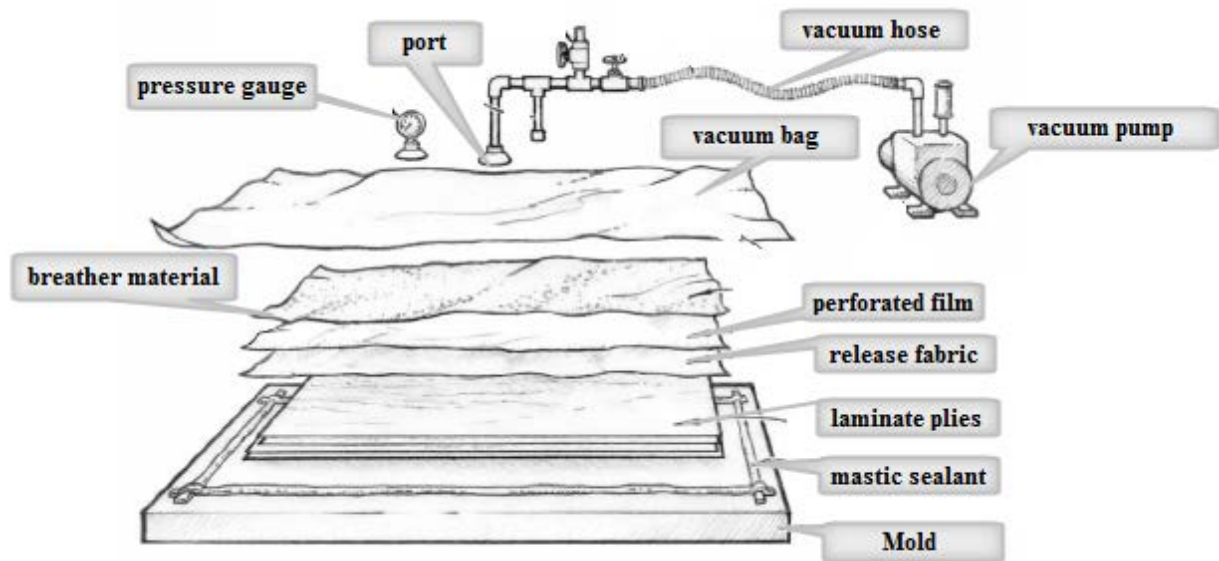

Figure 3.6: Vacuum bagging system [31]

The above figure shows the different equipments which are used for vacuum bagging process. Some of the basic once are vacuum pump; mold, mastic sealant, breather material, hose and the like which are used in this paper. So their description and use are given as follows.

Vacuum pump

The heart of a vacuum system is the vacuum pump. Powered vacuum pumps are mechanically similar to air compressors, but work in reverse so that air is drawn from the closed system and exhausted to the atmosphere.

Vacuum pumps are designated by their vacuum pressure potential or “Hg maximum” (Hg is the chemical symbol for mercury), their **displacement in cubic feet per minute (CFM)** and the horsepower required to drive the pump. Selection of the pump is based on this parameter. Especially the first two are basic.

Pump selection

The size and shape of the mold and type and quantity of the material being laminated determine the minimum pump requirements. If you are laminating flat panels consisting of a few layers of glass, flat veneers or a core material, 5" or 6" Hg (2.5–3 psi) vacuum pressure will provide enough clamping pressure for a good bond between all of the layers. If the area of the panel is limited to a few square feet, a 1 or 2CFM pump will be adequate to maintain that clamping pressure. As the panel area increases, the CFM requirement increases proportionately.

A displacement of 3.5 CFM may be adequate for up to a 14' panel; for larger jobs, a pump with a displacement of 10 CFM or more may be required. Poor seals in the plumbing system or an envelope, or material which allows air leakage, will require a larger capacity pump to maintain satisfactory vacuum pressure. The more airtight the system, the smaller the pump you'll need [31].

This paper used available vacuum pump from the laboratory without performing the selection criteria, this is because it is difficult to get the desired vacuum pump. As a result single stage high vacuum pump DS 40 which is a product of JAVAC plc is used and shown in the figure below.



Figure 3.7: Vacuum pump

Release fabric

Release fabric is a smooth woven fabric that will not bond to epoxy. It is used to separate the breather and the laminate or the vacuum bag and the laminate. Excess epoxy can wick through the release fabric and be peeled off the laminate after the laminate cures. It will leave a smooth textured surface that, in most cases, can be bonded to without additional preparation. Surfaces that will subject to highly-loaded bonds should be sanded. The fabric is available on the market and shown in the figure 3.8.



(a)

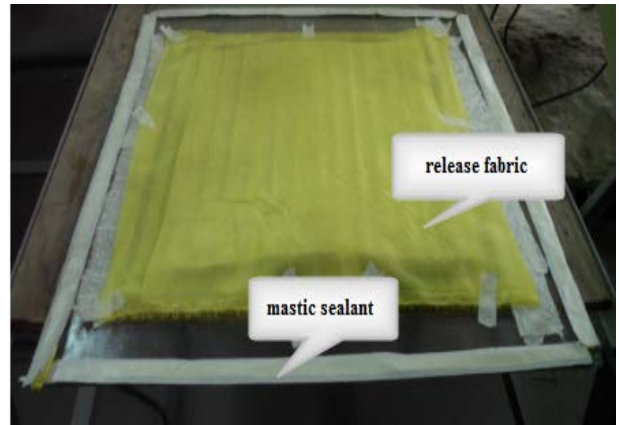

(b)

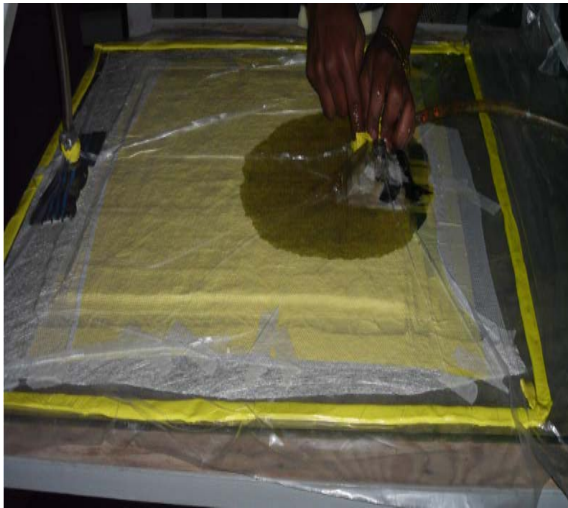

(c)



(d)

Figure 3.8: Release fabrics a) Shows the fabric, b) Shows the fabric attachment on the laminate, c) The fabric during the process and d) Shows the fabric when it was removed from the laminate.

Perforated film

A perforated film may be used in conjunction with the release fabric. This film helps to hold the resin in the laminate when high vacuum pressure is used with slow curing resin systems or thin laminates. Perforated films are available in a variety of holes size and patterns depending on the clamping pressure, and the resin's open time and viscosity. For this purpose, the following perforated film is used which is obtained from the market and it is shown in the figure 3.9.



(a)

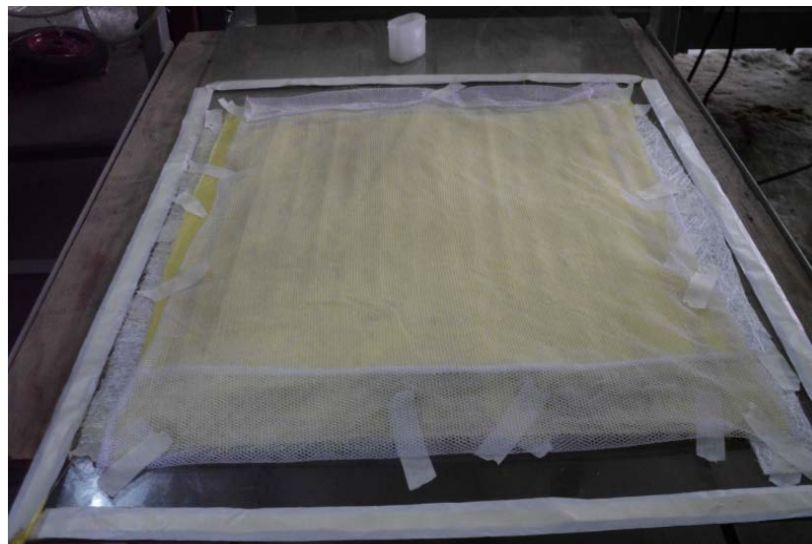

(b)

Figure 3.9: (a) shows the perforated film alone and (b) the perforated film during the attachment over the release fabric.

Vacuum bag

The vacuum bag, in most cases, forms half of the airtight envelope and it require about 20% larger than the maximum size of the mold. Clear plastic is preferable to an opaque material to allow easy inspection of the laminate as it cures. For higher pressure and temperature applications, specially manufactured vacuum bag material should be used round the laminate. The figure below shows vacuum bag before and during the process.



(a)



(b)

Figure 3.10: Vacuum bag (a) Before, and (b) During the process

Mastic sealant

Mastic is wide rubbery material that sticks to both the mold and the bagging material used to provide a continuous airtight seal between the bag and the mold around the perimeter of the mold. The mastic may also be used to seal the point where the manifold enters the bag and to repair leaks in the bag or plumbing. The mastic is not available in the local market but it is found in international market in roll form and it is shown in the figure below.



(a)

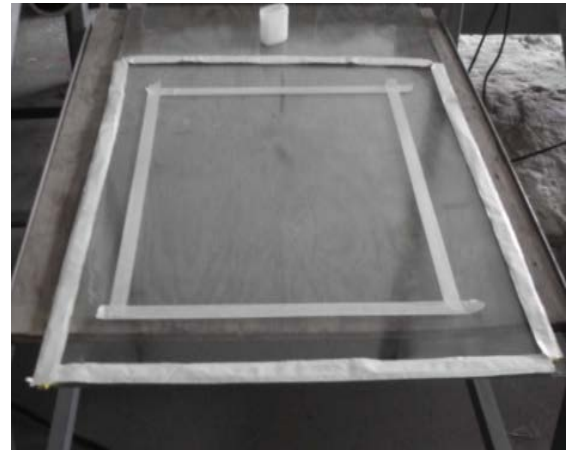

(b)

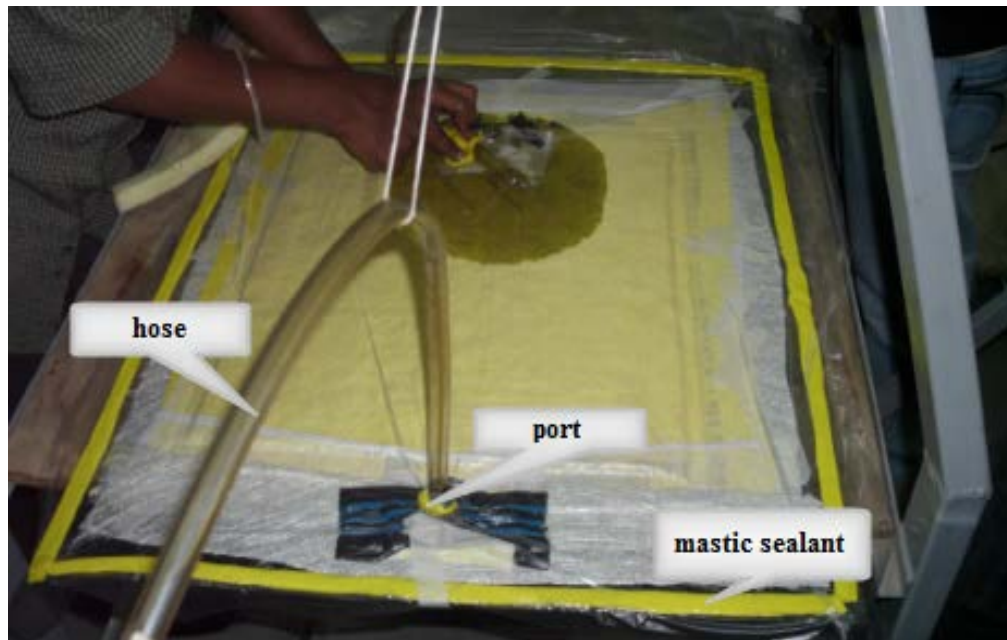

(c)

Figure 3.11: (a) Mastic roll, (b) Mastic attached to the mold and (c) mastic sealant during the process.

The plumbing system material

The plumbing system provides an airtight passage from the vacuum envelope to the vacuum pump, allowing the pump to remove air from the envelope and then reduce air pressure in the envelope. A basic system consists of flexible hose or rigid pipe, a trap, pressure gauge, control valve and a port that connects the pipe to the envelope. But in this research rigid hose and vacuum port are used and shown in figure 3.11.

Rigid hose connects the vacuum pump to the envelope and the matrix to the envelope. This hose can be flexible and rigid. Sometimes especial hose can be used for specific purposes.

Vacuum port connects the exhaust tubing to the vacuum bag. It can be designed specifically for the purpose or built from commonly available materials. One of the simplest ports is a hollow suction cup that sits over a small slit in the vacuum bag. Port1 is a port used to remove air from the envelope and have a breather to block the matrix from entering into the vacuum pump. And port 2 is used to feed matrix to the laminate. The attachments are shown in the figure below.



(a)



(b)

Figure 3.12: Vacuum port a) port 1, b) port 2

Mold release

Mold release is essential for preventing the epoxy from sticking to the mold when laminate part from the mold. There are generally three types of mold release used depending on the mold material and desired characteristics of the finished part. The most common type is a carnauba based paste wax. Fine detail and gloss level is obtained with the use of paste wax, but it can be difficult to buff anything with a textured surface.

The second type of release is the semi-permanent formulation. Many different manufacturers provide liquid release systems that apply much easier than paste wax and last for multiple parts on one application of the product. Generally a sealer and a release are used to provide the best results for new molds. Fine detail and gloss level is obtained as well as texture since buffing to remove excess is not usually necessary.

The final type of mold release is of the general contaminant variety. This can range from things like grease and Vaseline to toilet bowl wax, hair spray, hair gel or even clear packaging tape. These are generally used on rough or porous surfaces where detail, glosses, and texture are not issues for the final part [31].

In this research Vaseline is used as a release agent as shown in the figure below.

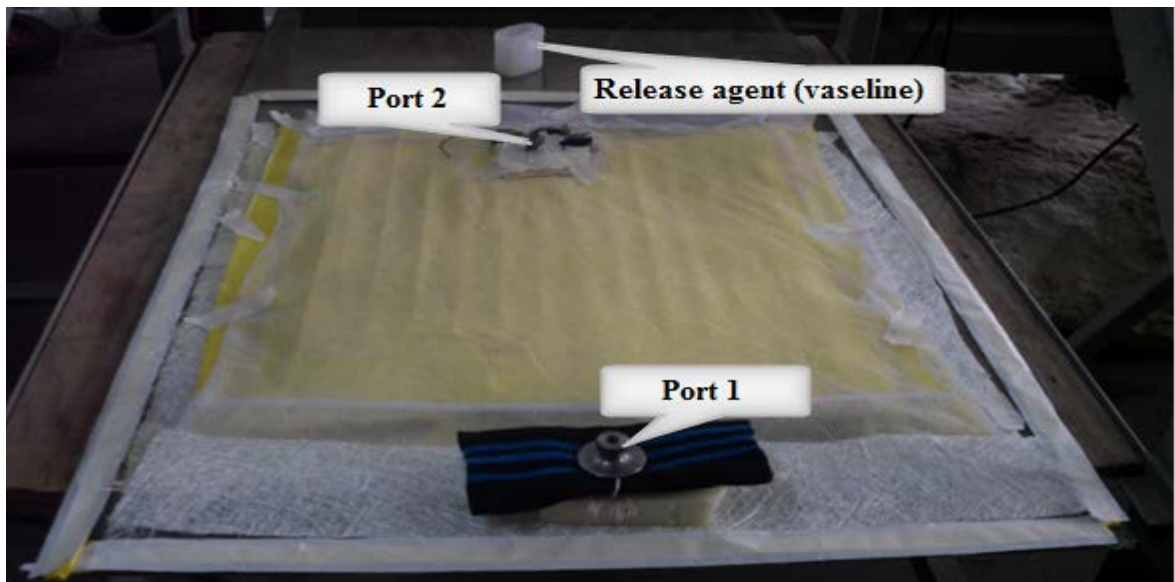

Figure 3.13: The vacuum system and the release agent

Vacuum Bagging Molds

Vacuum bagging molds vary widely in shape, size, and method of construction. Generally they are designed to perform two functions. They must hold the wet-out laminate in a specific shape until the resin system has cured and form half of an airtight envelope that contains the laminate. Some small molds are designed to fit completely inside an envelope and only need to be rigid enough to hold the laminate's shape.

The mold surface must be airtight and smooth enough to prevent bonding to the laminate.

Porous surfaces such as wood should be coated with epoxy or covered with a material such as plastic laminate to provide the necessary airtight surface. Each part produced in the mold will have a rough (bag) side and a smooth (mold) side. In most cases, the smooth, mold side of the laminated part will be its outer finished surface. Great care in finishing a mold surface will result in a part with a smoother surface finish. The appropriate mold release, most commonly paste wax, will allow the laminate to release cleanly from the surface.

The mold structure must be rigid enough to support the mold surface in its proper shape during the laminating process. Vacuum bagging molds take advantage of the fact that atmospheric pressure is equal everywhere on the outside of the envelope. The atmospheric pressure on the back of the mold will counteract all of the clamping pressure on the face of the mold.

A mold only needs to be strong enough to hold its shape against the spring back of the material being laminated. The quantity and stiffness of the laminate, the degree of compounding of the mold shape, the size of the mold and the precision of the finished laminate are factors that increase the amount of reinforcing required to stiffen the mold [31].

Glass plate is used as a mold in this finding because the final product is a plate like material. The glass mold is shown in the figure below.

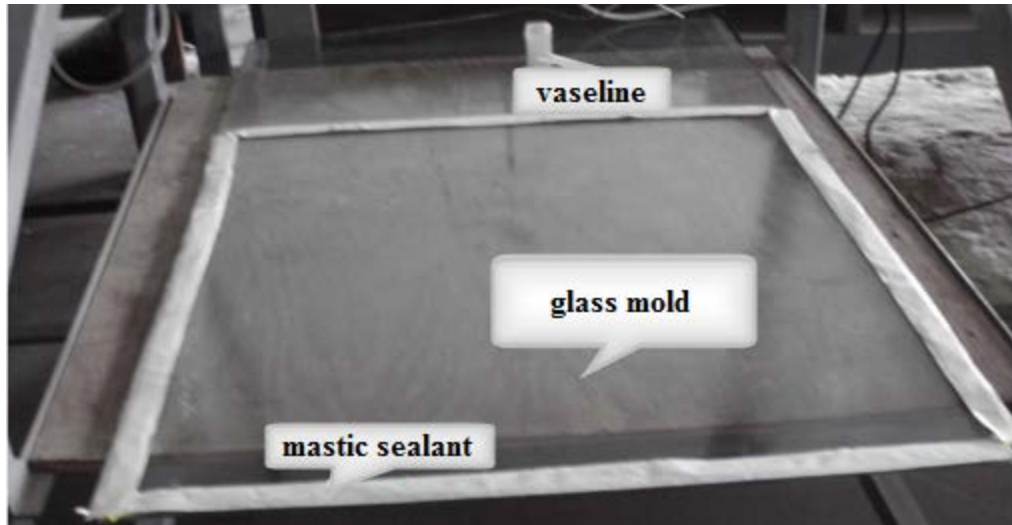

Figure 3.14: Glass mold

Care should be taken during delaminating process which is a process that includes starting from detaching the vacuum bag to release fabric and the mold from the laminate especially if proper release agent is not applied. This is because the glass mold may break during the process.

3.2 Fabrication

In this paper hand lay-up and vacuum bagging techniques was used as fabrication method. The techniques are described as follows.

3.2.1 Hand lay-up technique

In this process, liquid resin is applied to the mold and then reinforcement is placed on the top. A roller is used to impregnate the fiber with the resin. Another resin and reinforcement layer is applied until a suitable thickness builds up. It is a very flexible process that allows the user to optimize the part by placing different types of fabric and mat materials. This process requires less capital investment and expertise and is therefore easy to use.

The schematic diagram for hand lay-up process is shown in figure 3.15, where the thickness of the composite part is built up by applying a series of reinforcing layers and liquid resin layers. A roller is used to squeeze out excess resin and create a uniform distribution of the resin throughout the surface. By the squeezing action of the roller, homogeneous fiber wetting is obtained. The part is then cured mostly at room temperature and, once solidified; it is removed from the mold.

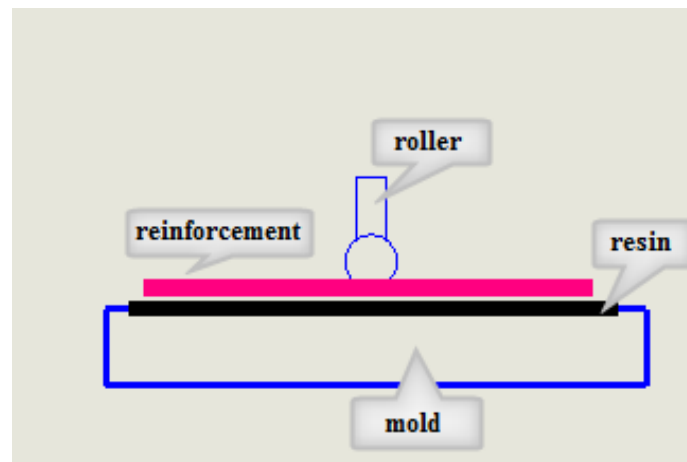

Figure 3.15: A typical schematic diagram for hand lay-up

Basic Processing Steps

The major processing steps in the hand lay-up process to prepare the partition wall include:

1. The mold is cleaned and prepared for use.
2. Release agent (Vaseline) is applied to the mold.
3. Apply liquid resin to the mold.

4. The reinforcement layer is placed on the mold surface and then it is impregnated with resin. Sometimes, the wetted fabric is placed directly on the mold surface. The reinforcement are placed in the following order. Front layer, decorated cotton is used and second traditional woven fiber is used and finally one layer of 300 g fiberglass is used.
5. Using brush, resin is uniformly distributed over the laminate and consolidation is made between the laminate and the mold.
6. The part is allowed to cure at room temperature overnight.

Advantages of the hand Lay-Up Process

The wet lay-up process is one of the oldest composite manufacturing techniques with the following advantages:

1. Very low capital investment is required for this process because there is a negligible equipment cost as compared to other processes.
2. The process is very simple and versatile. Any fiber type material can be selected with any fiber orientation.
3. The cost of making a prototype part is low because a simple mold can be used to make the part. In addition, the raw material used for this process is resin, mat, and fabric material, which are less expensive.

Disadvantages of the hand Lay-up process

The wet lay-up process has the following limitations:

1. The process is labor intensive.
2. The process is mostly suitable for prototyping as well as for making large structures.
3. Because of its open mold nature, styrene emission is a major concern.
4. The quality of the part produced is not consistent from part to part.
5. The process is not clean.

The final product using hand lay-up technique is shown in the figure 3.18. The product had some defect on its surface.



(a)

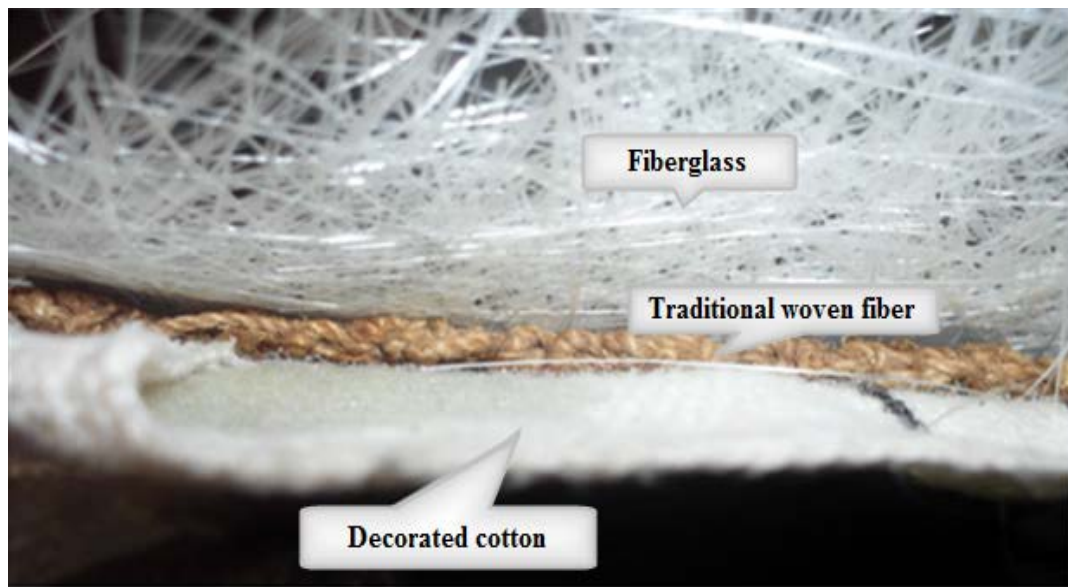

(b)

Figure 3.16: Sample partition wall, a) Lateral surface, b) Longitudinal cross section

To improve the quality of the product and its surface finish other production technique is used that is vacuum bagging technique and described as follow in the next section of the paper.

3.2.2 Vacuum bagging technique

Vacuum bagging uses atmospheric pressure as a clamp to hold the laminate plies together. The laminate is sealed within an airtight envelope. The envelope is an airtight mold on one side and an airtight bag on the other. When the bag is sealed to the mold, pressure on the outside and inside of this envelope is equal to atmospheric pressure and the schematic diagram is shown in figure 3.19 (a). Then it use a vacuum pump which evacuates air from the inside of the envelope, air pressure inside of the envelope is reduced while air pressure outside of the envelope remains at atmospheric pressure and it is shown in figure 3.19 (b). Atmospheric pressure forces the sides of the envelope and everything within the envelope together, putting equal and even pressure over the surface of the envelope.

The pressure differential between the inside and outside of the envelope determines the amount of clamping force on the laminate. The schematic diagram for this process is shown in the figure below.

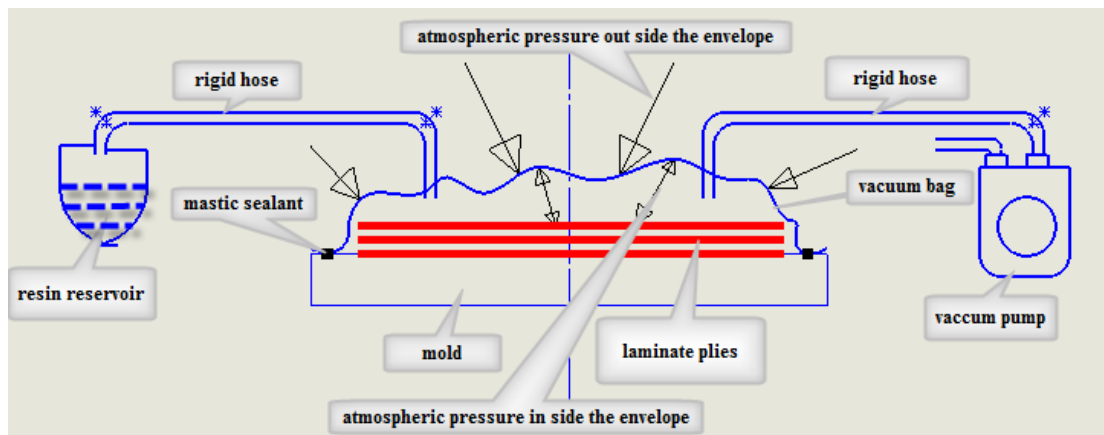

(a)

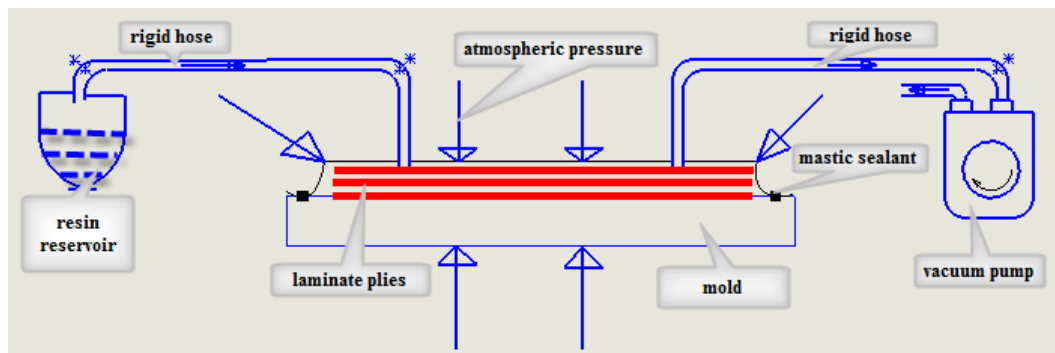

(b)

Figure 3.17: A typical vacuum bagging lay-up before and after vacuum is applied

Basic Processing Steps

The major processing steps in the vacuum lay-up process to prepare the partition wall include:

1. The mold is cleaned and prepared for use.
2. Apply release agent (Vaseline) to the mold.
3. Apply the mastic sealant around the perimeter of the mold.
4. Prepare the materials to be laminated and cut fabric and perforated film with appropriate size.
5. Put the laminate on the mold surface and attach the fabric and the perforated film over the laminate respectively.
6. Attach the port over the perforated film.
7. Attach the vacuum bag with the mastic sealant.
8. Cut the vacuum bag around the port to attach the fixed hose.
9. Attach the hose in their position.
10. Operate the vacuum pump and check leaks throughout the system.
11. Mix resin and hardener and feed to the system.
12. Observe the resin distribution over the laminate.
13. Stop feeding the resin hardener mixture , when it reaches the tip of the laminate and
14. The final process is delaminating the vacuum bag, the perforated film and release fabric from the laminate.

Advantages of vacuum bagging

The basic advantage of this processing technique:-

- Even clamping pressure
- Control of resin content
- Efficient laminating
- Custom shapes and have other minor advantages

Disadvantage of vacuum bagging

- It requires a small capital investment due to the equipment it uses
- It needs skill to make a huge and complex product

DESIGN AND ANALYSIS OF THICK PARTITION WALL FOR BUILDING FROM LOCAL COMPOSITE"ENSET" FIBER

Using a vacuum bagging technique a better quality partition wall prototype was made especially the surface finish was smart compared to the previous hand lay-up technique. The figure below shows the product made from this technique. Product A is made from traditionally woven fiber while product B is made from manually prepared woven fiber which is made in the laboratory.



(a)



(b)

Figure 3.18: Sample partition walls made using vacuum bagging technique a) product A, b) product B

CHAPTER FOUR

EXPERIMENT SET UP

In these research three categories of experiments was conducted. These were bending, compression, and impact. Bending and compression test was performed on a universal tensile test machine which is available in Addis Ababa Institute of Technology, Mechanical Engineering material laboratory. Impact test was made in non-standard way using penetrometer machine with some modification.

The experimental set up for each category is described as follows:

4.1 Experiment set up for three point bending tests

Three and four-point bending tests in laminate composite shows characteristics in their mechanical responses. Most researchers perform the bending test in composite material to deal with the fracture characteristic of the material. But in this paper the test is conducted to know some mechanical properties of the proposed material.

The specimen was prepared based on ASTM C393 OO and it was 120mm long, 30mm wide and has 16mm thickness which is shown in the figure below. The production method used to prepare the specimen was a hand lay-up method.



Figure 4.1: Bending specimen

DESIGN AND ANALYSIS OF THICK PARTITION WALL FOR BUILDING FROM LOCAL COMPOSITE"ENSET" FIBER

The specimen had some imperfection in its size and cross-sectional area due to lack of proper cutting tool, like wire cutting tool, and poor method of production. The specimen had two different surfaces due to the production technique. The mold side of the specimen surface is rich in resin and the back side is fiber rich.

The set up for three point bending test is shown in the figure.

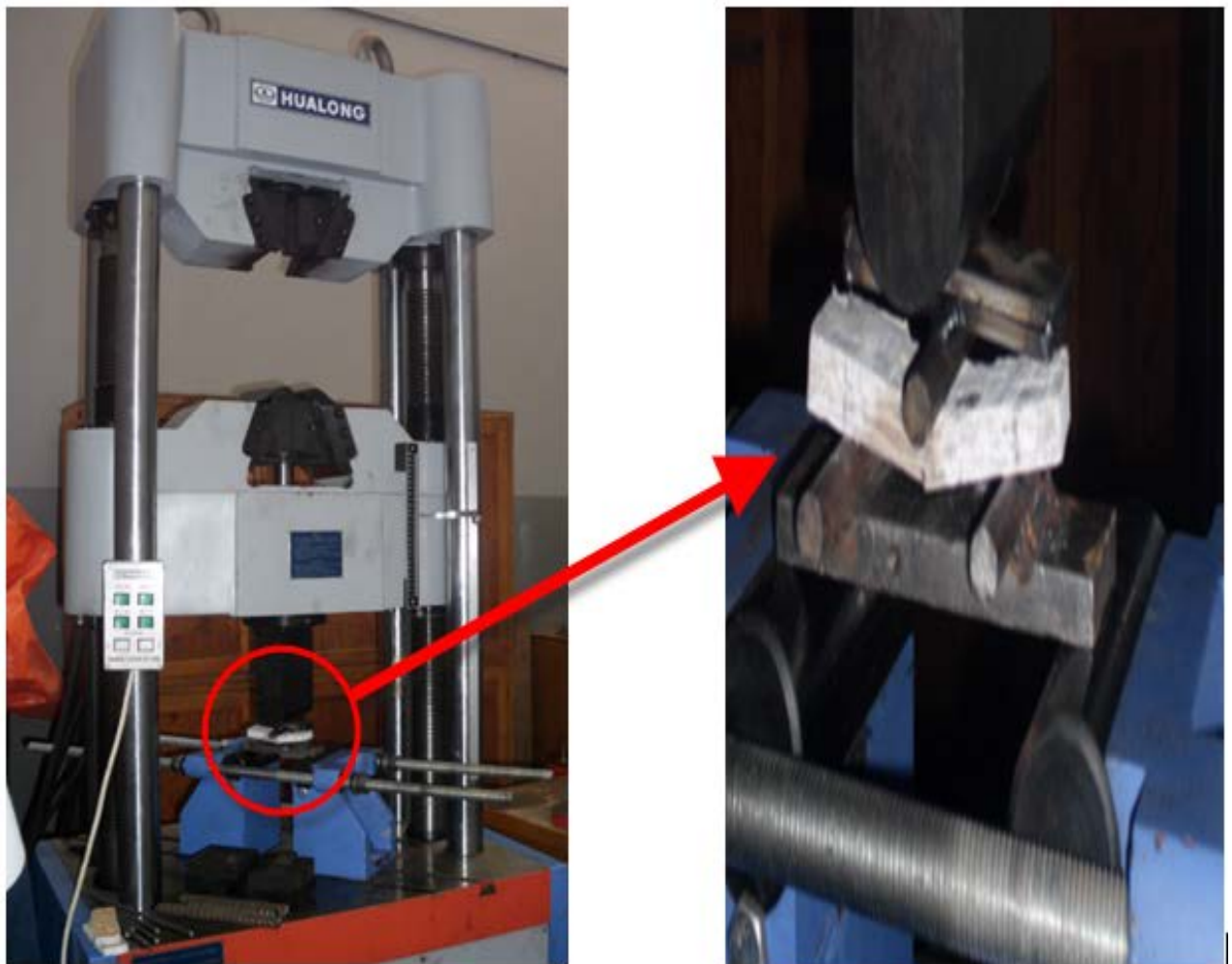

Figure 4.2: Three point bending set up

In figure 4.3 two dimensional drawing of three point bending set –up is shown. In this figure the roller spacing and the point of the application of the load is shown which is in the mid span of the specimen.

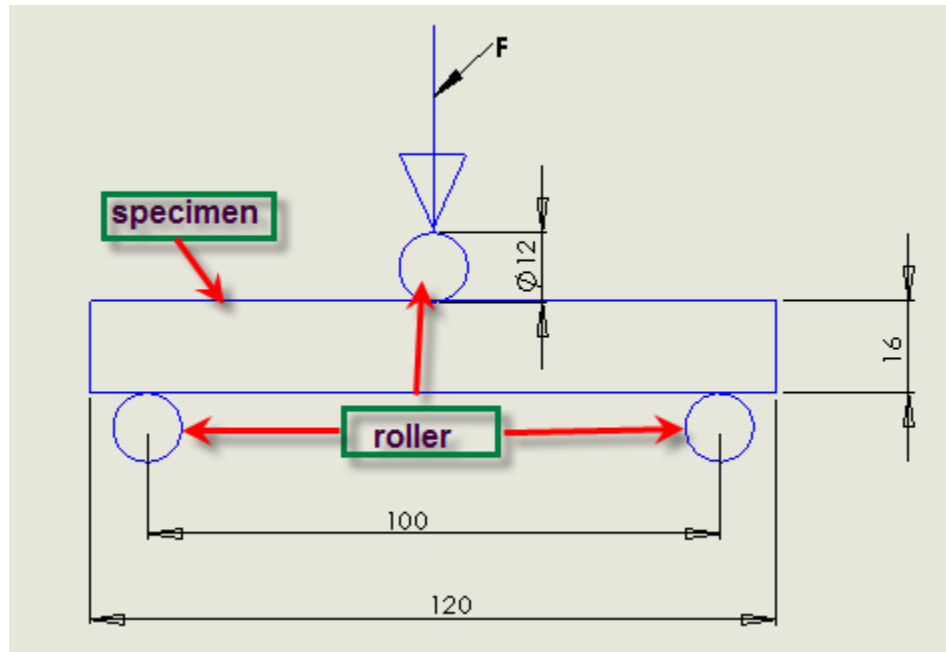

Figure 4.3: Two dimensional drawing of three point bending

Three bending test were performed, two in the fiber rich surface and the other in resin rich surface. The test machine is integrated with computer to draw the displacement versus force graph and it uses a hydraulic system to apply the load on the specimen.

4.2 Experiment set up for flat-wise compression test

Compression test is a basic test for structural material and others. It tells us the load carrying capability of the material. Compression testing of composite laminates is important for establishing failure limits as well as material quality control. So the proposed material for partition wall was tested in this test.

The specimen is prepared based on ASTM 365-94 and it had 32mm long, 32mm wide and a 16mm thickness. The production method used to prepare the specimen was a hand lay-up method which is similar to the bending specimen.

This specimen also had some imperfection due to the previously mentioned points like lack of proper cutting tool and poor production technique used to manufacture the specimen.

The set up for flat-wise compression test is shown in the figure4.4.

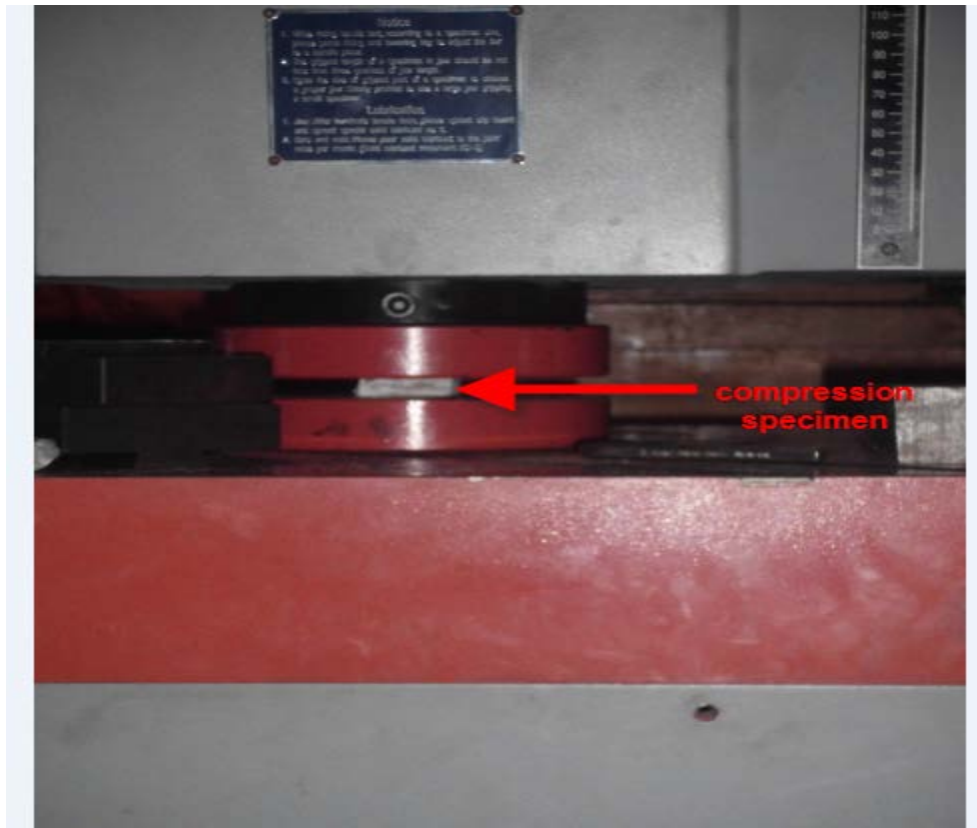

Figure 4.4: Compression test setup

4.3 Impact test setup

Impact testing is the other test which is performed on the proposed material. This test is conducted to know the ability of a material to absorb energy. In this research gypsum board and the proposed material was tested.

The test was performed in a non-standard way using Penetrometer, Soil Impact Tester, with some modification and it's available in the Addis Ababa institute of Technology, Civil Engineering Department, Soil laboratory. This test machine is used to measure the penetration resistance of soils by means of a dynamic cone (indenter) and identify the upper and lower positions of layers of different soil strengths.

The specimen used for impact test was made from Enset traditional mat material, one layer of fiberglass and resin using hand lay-up technique. The specimen was 250mm long, 200mm wide

and 5mm thickness. The gypsum board specimen had the same size but with different thickness. The thickness for gypsum board was 8mm.

The experimental set up for this test is shown in the figure. The impact load was thrown from the tip part of the penetrometer within the given height difference and the given speed. Then the dynamic cone (indenter) would apply the load to the specimen surface. And finally the specimen response to the load was observed. So in this way the experiment was conducted.

The test was conducted by varying the impact load. In this test the load used are 3kg, 4.5kg, 6.5kg and 14kg and the loads are applied on the specimen one by one based on the procedure. Then the result is observed.

Finally the result would be compared between the two specimens and it would be discussed later in the next chapter of this paper.

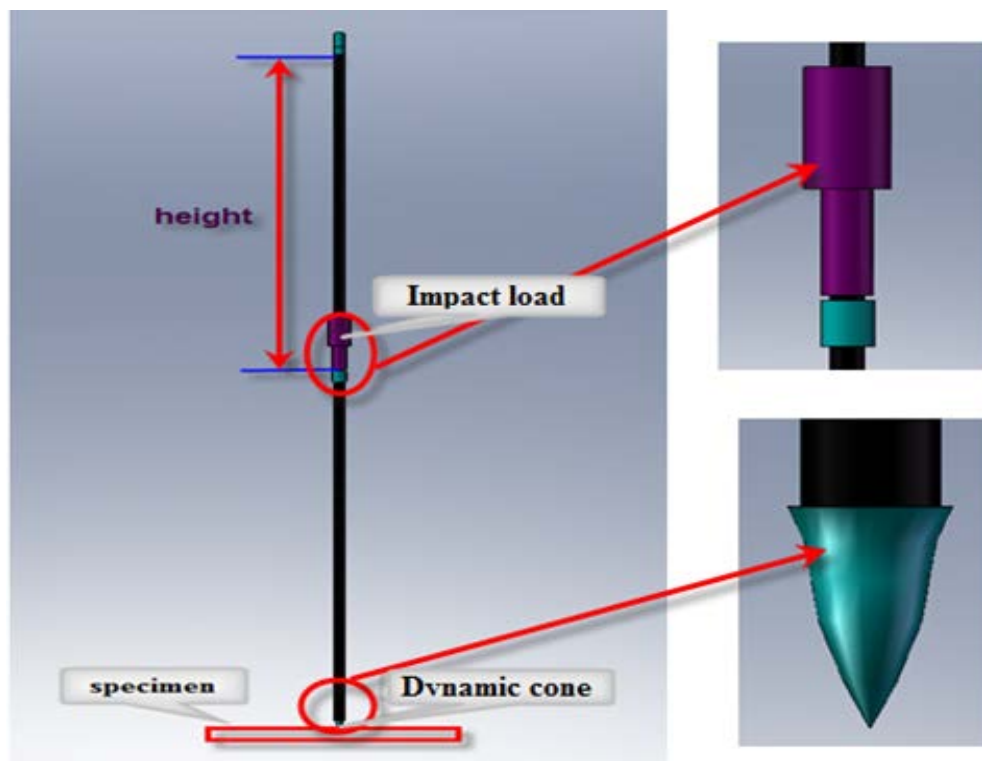

Figure 4.5: 3D view of impact test setup

The height difference between the initial and final position of the impact load is around 920mm. This helps to approximate the amount of energy absorbed by the specimen.

CHAPER FIVE

RESULTS AND DISCUSSION

5.1 Three point bending

The specimen for three point bending test was made using hand lay-up manufacturing process. The production technique employed brings in two different surface that is resin-rich (surface in contact with the mold) and fiber-rich regions (opposite surface), due to this the bending response of the composite of both surfaces was identified. As a result three bending specimens were prepared.

On the first specimen (NFC01) the load was applied in the fiber rich surface that means the compression side was the fiber rich surface and the tension side of the specimen was resin rich surface and the other two specimens, specimen (NFC02) and (NFC03) the load was applied in the resin rich surface which is opposite to the first specimen.

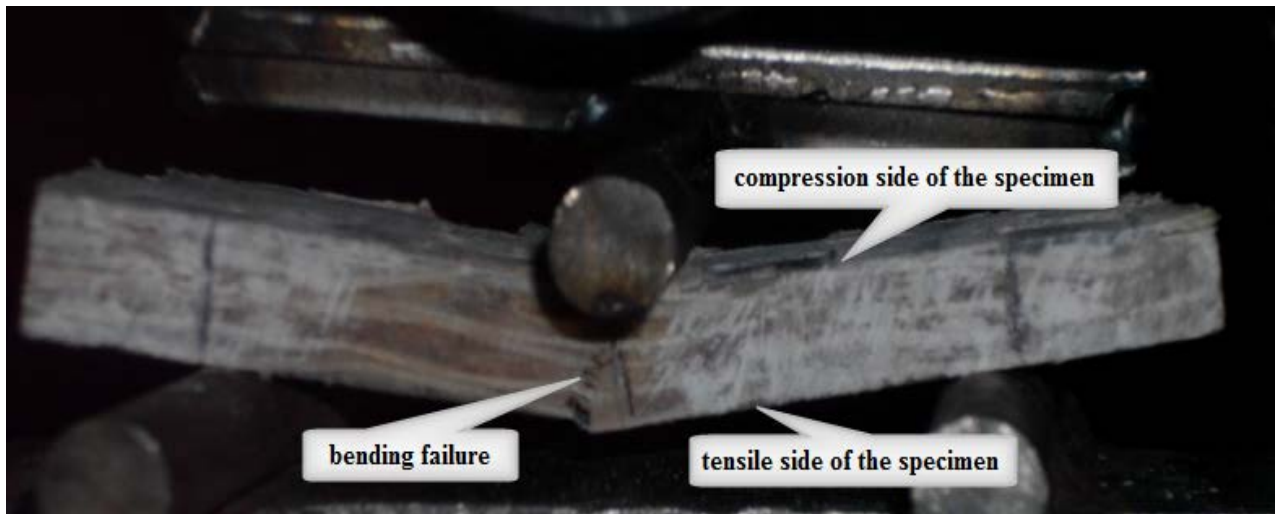

Figure 5.1: Illustration of the tension and compression side of the specimen

Specimen (NFC01)

The load was applied in the middle span of the specimen at a speed of 1.5 mm/min and data were collected from the computer which is integrated with the standard universal tensile test machine and the following results were obtained and they are indicated in table 5.1.

Table 5.1: Three point bending test result of specimen (NFC01)

Sample No.	Width mm	Thickness mm	F_{max} kN	E_c mm	E MPa	S_{max} MPa
NFC01	120.00	16.00	1.7	4.3	737.4	8.1

Where

F_{max} : - is the maximum load applied to the specimen and it is given in kilo Newton

E_c : - is the maximum deflection at the center of the specimen

E: - is elasticity modulus and it is given in mega Pascal (MPa) and

S_{max} : - is the maximum strength of the material and it is also given in mega Pascal (MPa)

The other result obtained from the computer was the stress vs. Displacement (strain) graph and are shown in the figure 5.1. From the figure it was observed that the crack initiated in the elastic deformation region of the material this is due to non- homogeneous properties of the material. The failure was occurred in a place where resin is rich. So it is possible to say that resin is the dominant factor in bending test.

The result also shows the maximum strength of the material and its deflection to be 8.1 MPa and 4.3 mm respectively. And the maximum force applied to the specimen is 1.7 kN.

The above mechanical properties can be improved if an advanced production technique is used. Like vacuum bagging, Pultrusion Process, Resin Transfer Molding Process and other advanced technique to make the material as much as possible uniform in its composition.

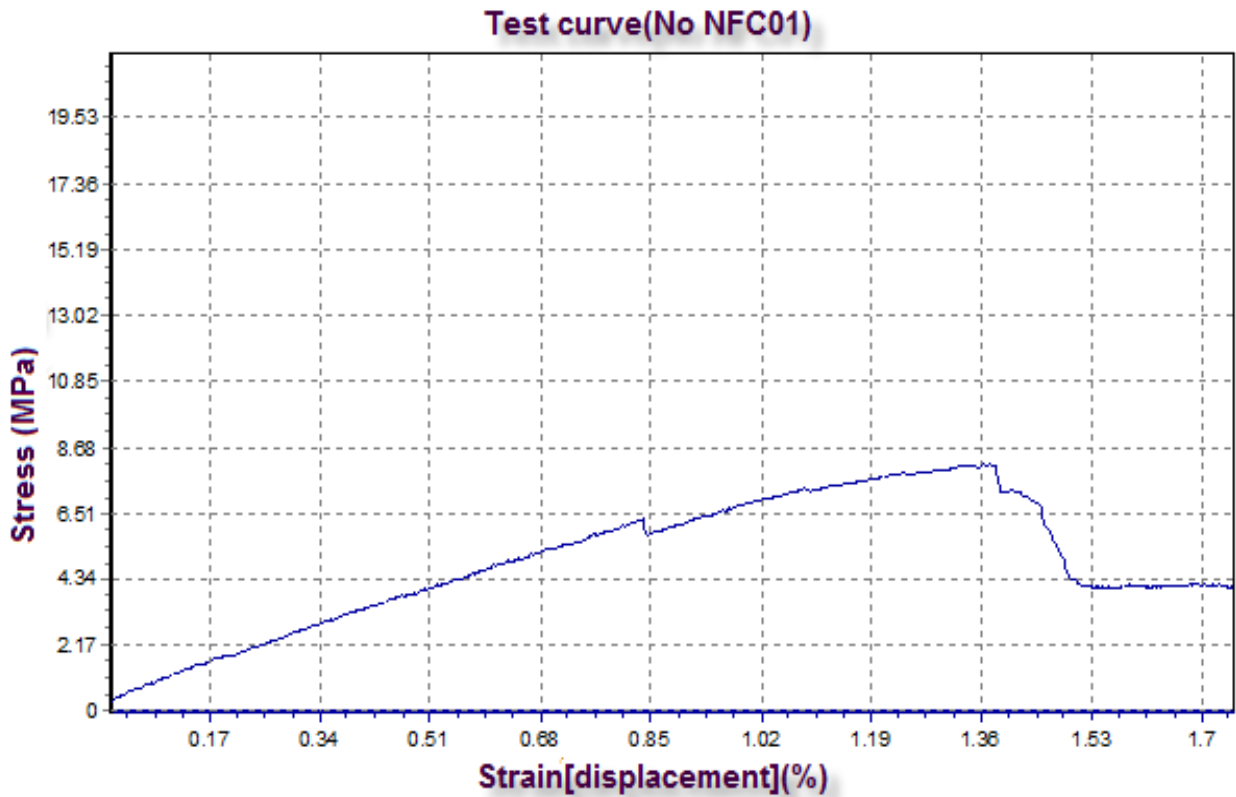

Figure 5.2: Stress vs. Displacement graph for specimen NFC01

Specimen (NFC02)

The specimen was tested in a similar manner except the speed load. In this case the speed load was 0.5 mm/min. The test result is indicated in the table 5.2.

Table 5.2: Three point bending test result of specimen (NFC02)

Sample No.	Width mm	Thickness mm	F_{max} kN	E_c mm	E MPa	S_{max} MPa
NFC02	120.00	16.00	2.2	4.9	557.1	10.7

Where

F_{max} , E_c , E and S_{max} are the maximum force, deflection, modulus of elasticity and the maximum strength of the specimen respectively.

The stress vs. the strain response of the specimen is given in the figure below for specimen (NFC02).

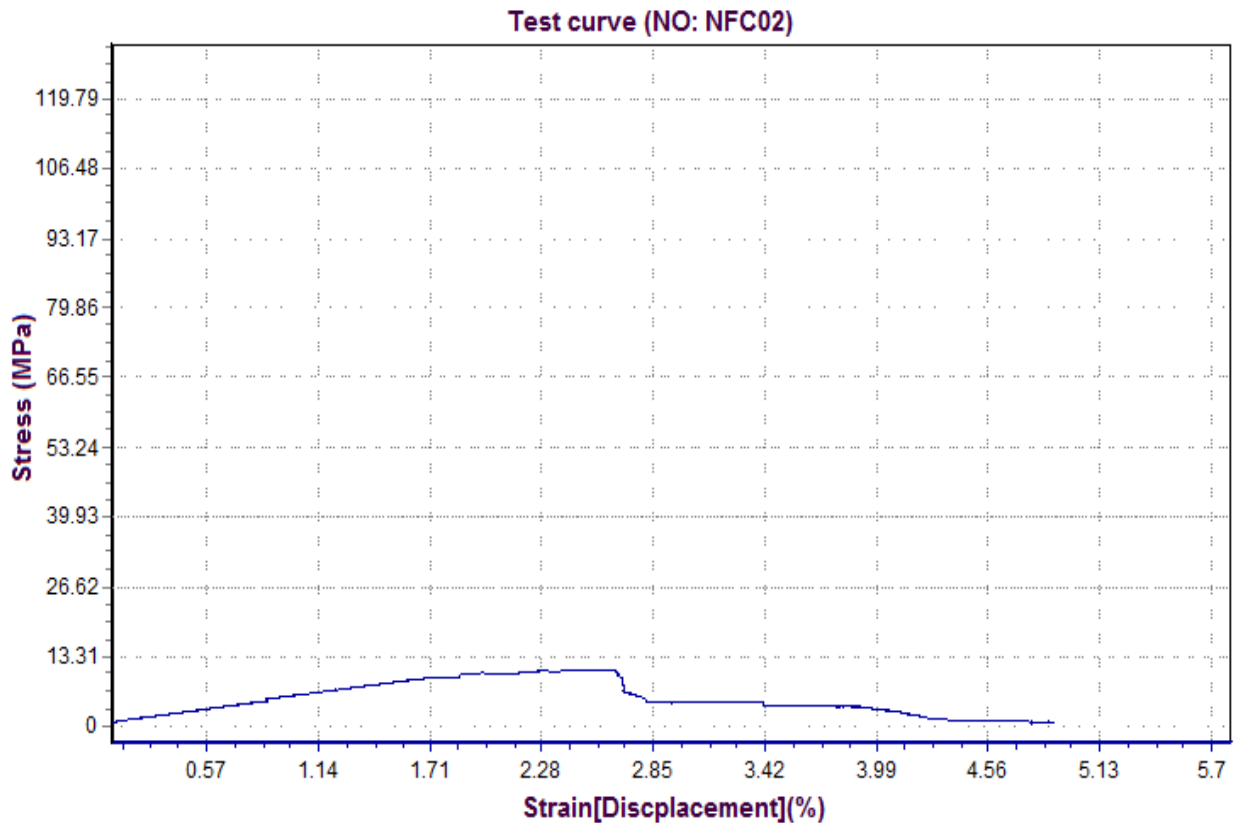

Figure 5.3: Stress vs. Displacement graph for specimen NFC02

In this result it can be seen that the maximum strength of the material is improved due to surface changes. In this case the load is applied in the resin rich surface that means the compression side of the specimen is resin rich and the tensile side is fiber rich and the tensile side with fiber rich surface responded in a better way than the tensile side with the resin rich surface.

As a result, the ultimate strength of the material became 10.7 MPa and its corresponding deflection is 4.9mm with the maximum applied load of 2.2kN.

Specimen (NFC03)

The specimen was tested in a similar situation with the previous one except the speed. In this test the speed is rated at 1mm/min.

The result is given in the table 5.3.

Table 5.3: Three point bending result for a specimen (NFC03)

Sample No.	Width mm	Thickness mm	Fmax kN	Ec mm	E MPa	Smax MPa
NFC03	120.00	16.00	3.5	6.2	738.6	17.1

The stress vs. strain graph for test specimen (NFC03) is shown in the figure 5.3. The result shows that a better mechanical property is got, when compared to the other two results. It is difficult to discuss the reason in this paper. It requires further research. However, the reason for such variation in mechanical property might be the production technique and type used, the cross sectional area of the materials, non homogeneous property of the materials and other.

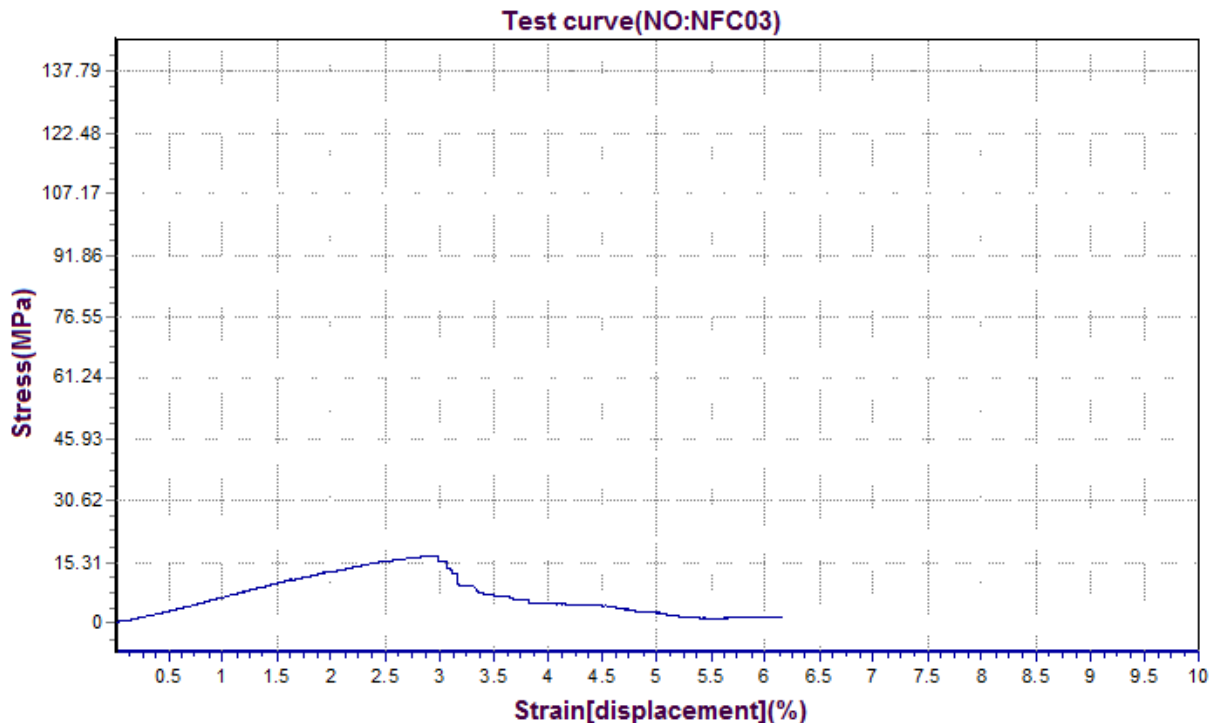

Figure 5.4: Stress vs. Strain graph of specimen (NFC03)

The ultimate strength of the material is 17.1 MPa and its corresponding maximum deflection is 6mm with the maximum force of 3.5 kN.

The average result of the three point bending test is given in the table 5.4. This result can be taken as the final mechanical property of the material.

Table 5.4: Average result of the three point bending test

Sample No.	Width mm	Thickness mm	Fmax kN	Ec mm	E MPa	Smax MPa
Average	120.00	16.00	2.46	5.13	667	11.96

The three bending experiment which were conducted in this paper are not enough to study the fracture. To study the fracture, there should be a number of specimen and their result considering different parameters. Then it will not be difficult. In fracture study, it is required to know the properties such as crack initiation, propagation and others. To perform this experiment a lot of equipment is required especially electron microscope of high revolution is basic.

As a conclusion the result obtained in the three point bending test is not bad for partition wall purpose this is because the partition wall is not load bearing material. The only load it has is the load which comes from furniture and materials in housing. However the mechanical property of the material can be improved by treating the fiber with chemicals to increase fiber resin adhesion.

5.2 Compression test

Specimen (NFC1): the result of this specimen under flat wise compression test is given in the table 5.5.

Table 5.5: Compression test results of specimen (NFC1)

Sample No.	Width h mm	Thickness mm	Fmax kN	Fuy kN	Fly kN	Fpy kN (0.2%)	Rmax MPa	ReH MPa	ReL MPa
NFC-1	40.00	14.00	618.1	256.8	256.1	256.5	1103.8	458.6	457.3

Where

F_{max} :- is the maximum applied load

F_{uy} :- is the upper yield

F_{ly} :- is the lower yield

F_{py} :- is the proof yield

R_{max} :- is the maximum compressive strength

ReH :- is the higher yield and,

ReL :- is the lower yield

The result of stress vs. the strain graph is given in the figure 5.4 . In this graph there is up and down and the curve is not smooth this is due to non-homogeneous property of the material since the resin and fiber distribution is not even.

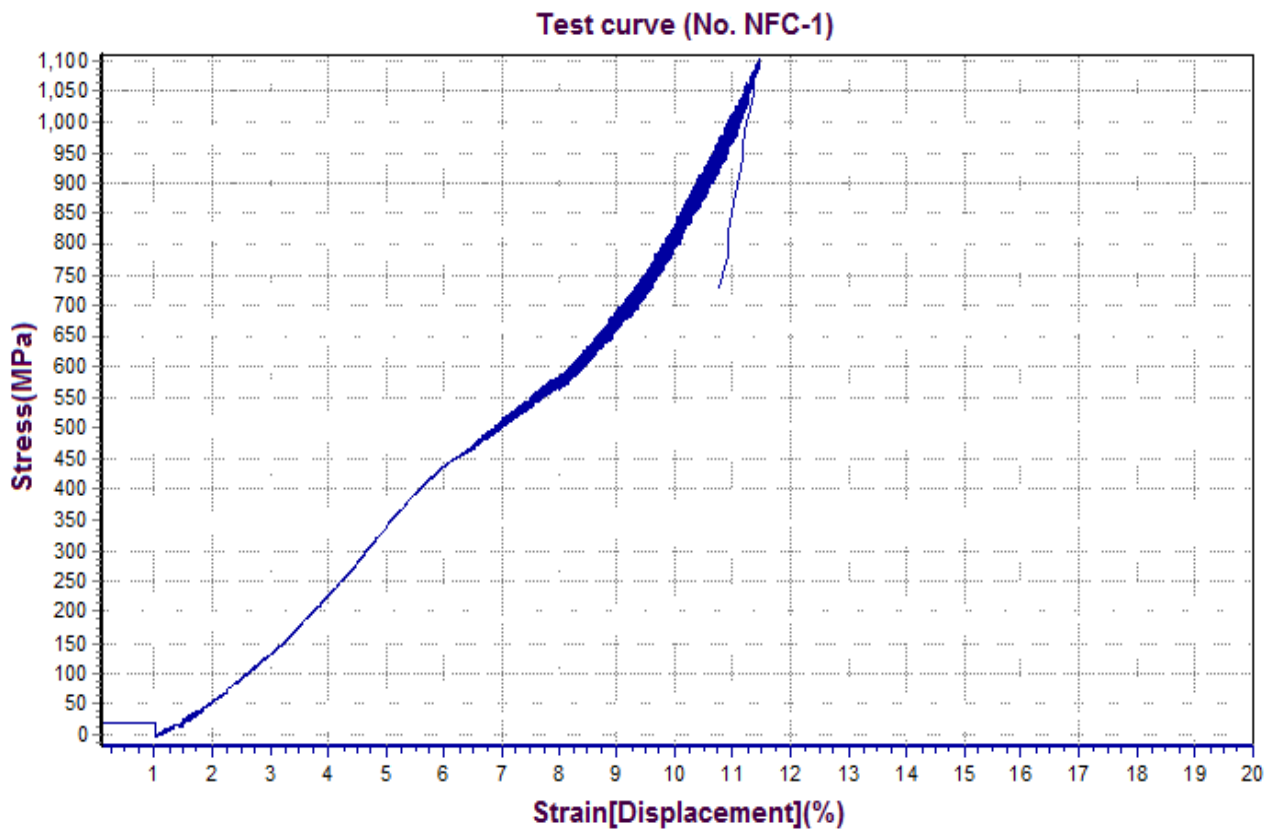

Figure 5.5: Stress vs. Strain graph of specimen (NFC-1)

Specimen (NFC-2): The compression test was made in a similar manner with specimen (NFC-1) in every aspect.

The test result is given in the table 5.6.

Table 5.6: Compression test result of specimen (NFC-2)

Sample No.	Width mm	Thickness mm	Fmax kN	Fuy kN	Fly kN	Fpy kN (0.2%)	Rmax MPa	ReH MPa	ReL MPa
NFC-2	40.00	14.00	617.4	252.7	246.9	249.4	1102.4	451.2	440.8

The stress vs. the strain graph is given in the figure below.

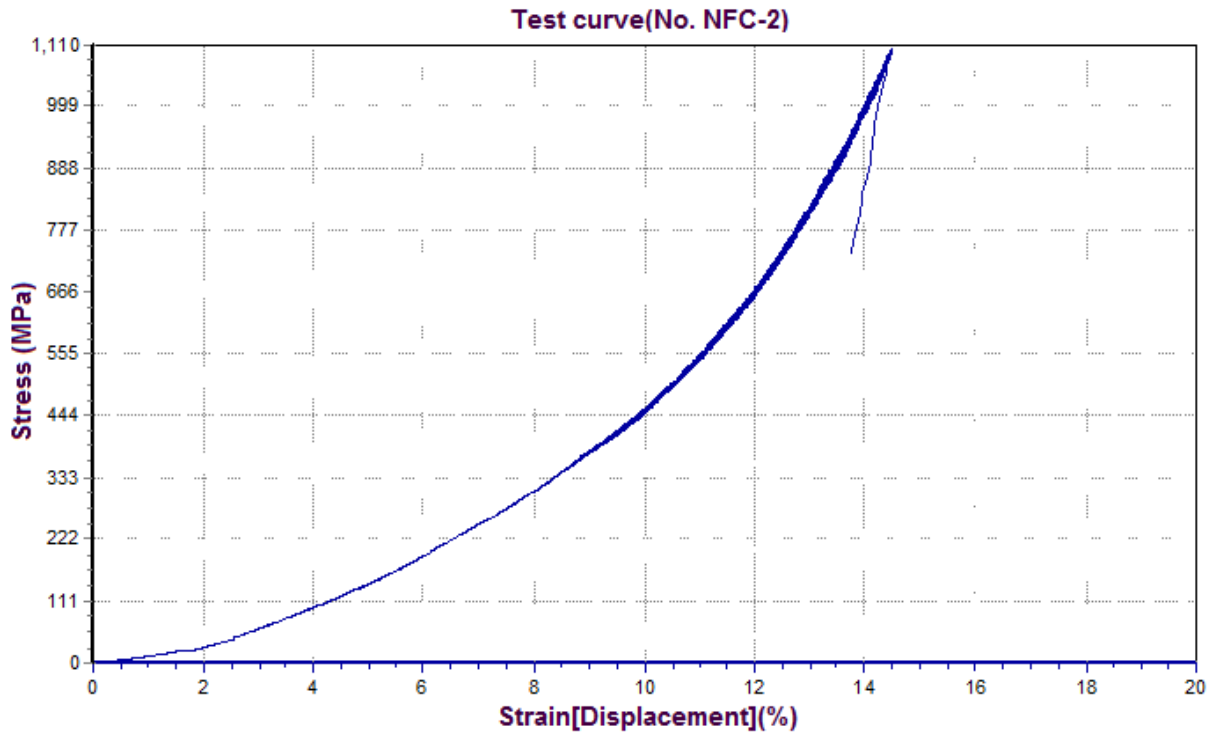

Figure 5.6: Stress vs. Strain graph of specimen (NFC-2)

The average compressive result of the two tests is given the table below.

Table 5.7: Average compression test result of specimen (NFC-2)

Sample No.	Width mm	Thickness mm	Fmax kN	Fuy kN	Fly kN	Fpy kN (0.2%)	Rmax MPa	ReH MPa	ReL MPa
Average	40.00	14.00	617.75	254.75	251.5	252.95	1102.4	451.2	440.8

The specimen after compressive test is shown in the figure. The specimen changed their size after the tests both have the dimension of around 40mm long, 40mm wide and 9mm thick.



Figure 5.7: Compressive failure (a) specimen (NFC-1), (b) specimen (NFC-2)

The result of the two flat wise compression tests shows that in the plastic region that means before the yield strength the curve was smooth while in the plastic region the curve shows up and down this indicate that the out surface is relatively more homogeneous than the interior surface. And the initiation point of the up and down part of the graph indicates the plastic region is getting closer and closer.

The average result of the test can be taken as the mechanical property of the material. Based on this the proposed material has the maximum compressive strength of 1102.4MPa, the higher yield stress 451.2, the lower yield stress 440.8 and other mechanical property can be referred from the table 5.7. Better result can be obtained if different layup orientation of the laminate is used.

This compression result of the material is enough for non-load bearing partition wall since there is no critical load subjected to the non-load bearing partition. The test is made for the purpose of characterizing the mechanical property of the proposed material.

5.3 Impact test

There is no standard impact test machine available in the laboratory that vary the impact load or speed and that give the contact force history during impact and the resulting impact energy. So in this paper penetrometer, soil impact test machine with some modification was used to compare gypsum board and the proposed material. As a result two type of specimen was prepared.

Gypsum board

Three gypsum sample specimen was tested for impact all are identical in every respect. Sample specimen-1 with impact load of 3Kg, sample specimen-2 was tested with 6.5Kg load and sample specimen-3 with 14kg. The response of the two specimens is shown in the figure 5.7.



(a)



(b)



(c)

Figure 5.8: Gypsum board impact damage (a) sample specimen-1, (b) sample specimen-2 and (c) sample specimen-3

From the result it is observed that as the impact load increase the damage on the specimen is reduced this is because as the load increase the time of the impact load on the specimen is minimized and the impact energy is maximized.

The gypsum board might fail under 3kg load. But this is not the point of interest in the paper, rather to compare the two materials.

Natural Enset fiber composite material

Four sample specimens were prepared from the new proposed material and all have the same size and composition. Here the specimens were tested for 3 kg, 4.5 kg, 6.5 kg and 14 kg of impact load.

The response of the material to the applied impact load is shown in the figure 5.8.

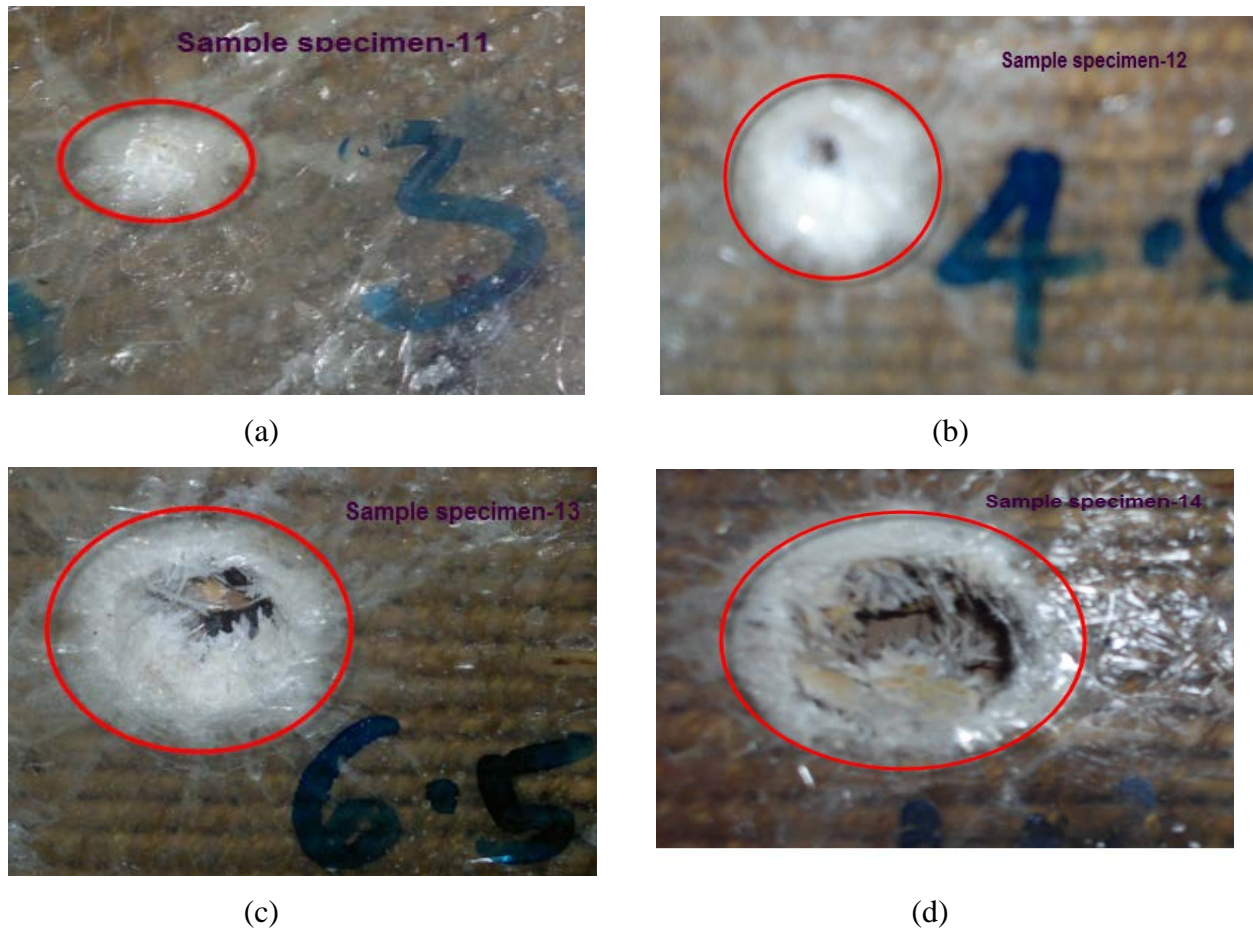

Figure 5.9: Impact damage (a) sample specimen-11, (b) sample specimen-12, (c) sample specimen-13 And (d) sample specimen-14

The impact speed and energy can be approximated using the principle of conservation of energy. The only load in the system is gravity but other force's like friction between the impact load and the road can be neglected. So the potential energy of the system is equivalent to the kinetic energy. Therefore, the speed of the impact load can be approximate as follows:

$$mgh = \frac{1}{2} mv^2 \quad 5.1$$

$$gh = \frac{1}{2} v^2$$

$$9.81 \text{ m/s} \times 0.92\text{m} = \frac{1}{2} v^2$$

$$v^2 = 18.05$$

$$v = 4.25 \text{ m/s}$$

Where:

m: - is a mass of the impact load

g: - is gravitational constant

h:- is the height difference between the initial and final position of the impact load and

v:- is impact load speed

The speed of the impact load is constant and it doesn't vary with the impact mass while the energy highly depends on the mass of the impact load. So the energy for each mass is calculated as follows:

$$E = mgh \quad 5.2$$

$$E1 = 3 \text{ kg} \times 9.81 \frac{\text{m}}{\text{s}^2} \times 0.92 \text{ m} = 27.07\text{J}$$

$$E2 = 4.5 \text{ kg} \times 9.81 \frac{\text{m}}{\text{s}^2} \times 0.92 \text{ m} = 40.61\text{J}$$

$$E3 = 6.5 \text{ kg} \times 9.81 \frac{\text{m}}{\text{s}^2} \times 0.92 \text{ m} = 58.66\text{J}$$

$$E4 = 14 \text{ kg} \times 9.81 \frac{\text{m}}{\text{s}^2} \times 0.92 \text{ m} = 126.35\text{J}$$

This result show that specimen-11 was able to absorb about 27.07 J of energy without critical damage to the specimen and the same is true for specimen-12 it absorbs about 40.61 J of energy but the damage is a little intensified. Even though specimen-13 and specimen-14 has got a significant damage, the failure is not critical. Since this failure doesn't affect the integrity of the entire product.

DESIGN AND ANALYSIS OF THICK PARTITION WALL FOR BUILDING FROM LOCAL COMPOSITE"ENSET" FIBER

From the result the two types of material that is gypsum board and composite material are not comparable with regard to impact test. Composite materials from the local fiber are stronger than the gypsum and it is simple to recover from the damage it considered.

As a result partition wall made from local composite material has a good absorber of impact load. It can absorb about 40.61 J of energy without critical damage. So the material can be used as a non-load bearing partition wall.

CHAPTER SIX

CONCLUSIONS AND RECOMMENDATION

6.1 Conclusions

The research was conducted to achieve its objective which was to design high quality partition wall from local Enset fiber. In achieving this objective, a lot of work was performed and the following conclusions are drawn.

- Enset fiber is a possible candidate to reinforce non-load bearing partition wall.
- Among the two production techniques used to produce sample partition wall, vacuum bagging technique was better to produce high quality product than the hand lay-up technique.
- High quality product which has cultural value, non-load bearing partition wall material was achieved.
- The mechanical property of the material was investigated through experiments such as the bending and compressive strength of the product.
- Impact resistance of the proposed material was much better than that of gypsum board. This means the proposed material absorb a significant amount of energy than that of the gypsum board.

6.2 Recommendation

The following areas are recommended for future work:

- Finding a new natural fiber from our endemic plants.
- Studying fracture analysis of composite materials made from Enset fiber
- Studying surface treatment of Enset fiber to improve adhesion between the fiber the matrix which result in a better mechanical property.

REFERENCE

1. Akil Md. Hazizan, and Cantwell W.J., “The Low Velocity Impact Response of an Aluminium Honeycomb Sandwich Structure”, *Composites: Part B* 34 (2003) 679–687.
2. Angelo G. Facc, Mark T. Kortschot, and, Ning Yan, “Predicting the Tensile Strength of Natural Fiber Reinforced Thermoplastics”, *Composites Science and Technology* 67 (2007) 2454–2466.
3. Autar K. Kaw, *Mechanics of Composite Materials*, second edition, Taylor & Francis Group, LLC, 2006.
4. Awal A., Cescutti G., Ghosh S.B. , and, Müssig, J. “Interfacial Studies of Natural Fibers Polypropylene Composites Using Single Fibers Fragmentation Test (SFFT)”, *Composites: Part A* 42 (2011) 50–56.
5. Beckermann G.W., and Pickering K.L., “Engineering and Evaluation of Hemp Fiber Reinforced Polypropylene Composites: Micro-Mechanics and Strength Prediction Modelling”, *Composites: Part A* 40 (2009) 210–217.
6. Carlos Leiva, Luis F. Vilches, Jose´ Vale, and Constantino FernándeZ-Pereira, “Fire Resistance of Biomass Ash Panels Used for Internal Partitions in Buildings”, *Fire Safety Journal* 44 (2009) 622–628.
7. Czigány.T and Morlin.B,” Development and Application of Microbond Test for Characterizing Fiber-matrix Adhesion”, Budapest University of Technology and Economics, 2009.
8. Department of Defense Handbook, *Composite Materials Handbook Volume 1. Polymer Matrix Composites Guidelines for Characterization of Structural Materials*. United states department of defense, Volume 1 of 5, JUNE 2002.
9. Djoko S.Riyanto, “Comparative Test Methods for Evaluating Shear Strength of Structural Lumber”, Unpublished Thesis, Oregon State University, 1996.
10. Fang Ming Zhao, Tomonaga Okabe, Nobuo Takeda, “The Estimation of Statistical Fiber Strength by Fragmentation Tests of Single-Fiber Composites”, *Composites Science and Technology* 60 (2000) 1965-1974.

11. Jose I. Restrepo, and Andrew M. Bersofsky, "Performance Characteristics of Light Gage Steel Stud Partition Walls", *Thin-Walled Structures* 49 (2011) 317–324.
12. Joung-Man Park, Pyung-Gee Kim, Jung-Hoon Jang, Zuoqia Wang, Byung-Sun Hwang, and Kenneth Lawrence DeVries" Interfacial Evaluation and Durability of Modified Jute Fibers Polypropylene (PP) Composites Using Micromechanical Test and Acoustic Emission", *Composites: Part B* 39 (2008) 1042–1061.
13. Kanakaji Chittineni, "Functionally Gradient Synthetic Foams", Unpublished Thesis, Louisiana State University, 2009.
14. Karger-kocsis J., "Instrumented Impact Fracture and Related Failure Behavior in Short and Long Glass Fiber –Reinforced Polypropylene", *Composites Science and Technology* 48(1993), 273-283.
15. Li Y.Y., and Cheng L., "Mechanisms of Active Control of Sound Transmission through a Linked Double-Wall System into an Acoustic Cavity", *Applied Acoustics* 69 (2008) 614–623.
16. Michael Brunig, and Larissa Driemeier, "Numerical Simulation of Taylor Impact Tests", *International Journal of Plasticity* 23 (2007) 1979–2003.
17. Mitek, "Guidelines for the Design and Fixing and Branching of Posi-Strut: Floor and Roof Truss System", Australia, 2007.
18. Osipov A., Mees P., and Vermeif G., "Low-Frequency Airborne Sound Transmission Through Single Partitions in Buildings", *Applied Acoustics*, Vol. 52, No. 3/4, pp. 213-288, 1997.
19. Per Nygard, and Claes-Goran Gustafson, "Interface and Impregnation Relevant Tests for Continuous Glass Fibers-Polypropylene Composites", *Composites: Part A* 34 (2003) 995–1006.
20. Prakash Tudu, "Processing and Characterization of Natural Fiber Reinforced Polymer Composites", Unpublished Thesis, National Institute of Technology Rourkela, 2009.
21. Raphael S. F, Eve M. F, Mirtânia A. L, and Sérgio R. L, "Bending in Laminas of NFPR: Type of Reinforcement, Fracture and Properties", *Materials Research*. 2011; 14(1): 67-72.

22. Rio Merino M., Santa Cruz Astorqui J., Hernandez Olivares F., "New Prefabricated Elements of Lightened Plaster Used for Partitions and Extrados", *Construction and Building Materials* 19 (2005) 487–492.
23. Roberts Joffe, Janis Andersons, and Lennart Wallstroma, "Strength and Adhesion Characteristics of Elementary Flax Fibers with Different Surface Treatments", *Composites: Part A* 34 (2003) 603–612.
24. Sanjay K. Mazumdar, *Composites Manufacturing: Materials, Product, and Process Engineering*, CRC press, 2002.
25. Shili-Pin Huang, Kuo-Tsai Chen, and Rong-Ping Lai, "Development of Standardized Impact Sources for Laboratory Measurement of Sound Transmission through Light Weight Walls", *Applied Acoustics* 58 (1999) 333-349.
26. The Association for Specialist Fire Protection (ASFP), *Fire Rated Non-Load Bearing Partitions ("The Purple Book")*, June 2003.
27. Torres F.G., and Cubillas, M.L. "Study of the Interfacial Properties of Natural Fibers Reinforced Polyethylene", *Polymer Testing* 24 (2005) 694–698.
28. Timothy Thamae and Caroline Baillie, "Influence of Fiber Extraction Method, Alkali and Silane Treatment on the Interface of Agave Americana Waste HDPE Composites as Possible Roof Ceilings in Lesotho", *Queens University, Canada*, 2007
29. Valadez-Gonzalez A., Cervantes-Uc J.M., Olayo R., and Herrera-Franco P.J., "Effect of Fiber Surface Treatment on the Fiber–Matrix Bond Strength of Natural Fiber Reinforced Composites", *Composites: Part B* 30 (1999) 309–320.
30. Vijay Kumar Thakur and Singha A S., "Natural Fibers-Based Polymers: Part I- Mechanical Analysis of Pine Needles Reinforced Biocomposites", *Bull. Mater. Sci.*, Vol. 33, No. 3, pp. 257–264, June 2010.
31. Wanga J., Lub T.J., Woodhouse J., Langley R.S., and Evans J., "Sound Transmission Through light Weight Double-Leaf Partitions: Theoretical Modelling", *Journal of Sound and Vibration* 286 (2005) 817–847.
32. WEST SYSTEM® Epoxy, *A guide to the principles and practical application of vacuum bagging for laminating composite materials*, 7th Edition, April, 2010.
33. Yan Li, Pickering K.L., and Farrell R.L., "Determination of Interfacial Shear Strength of

White Rot Fungi Treated Hemp fiber Reinforced Polypropylene", Composites Science and Technology 69 (2009) 1165–1171.

34. ASTM C 365-94 Standard Test Method for Flat Wise Compressive Property of Sandwich Cores. ASTM international, PA, USA.
35. ASTM C 393-00 Standard Test Method for Three Point Bending of Sandwich Cores. ASTM international, PA, USA.