

**QUANTUM ANALYSIS OF COHERENTLY
PREPARED DEGENERATE AND
NONDEGENERATE THREE-LEVEL LASERS**

A Thesis Presented to the

School of Graduate Studies

Addis Ababa University

In Partial Fulfillment

of the Requirement for the Degree

of Master of Science in Physics

by

Mesfin Abayneh

June 2001

ACKNOWLEDGMENT

I wish to express my deep gratitude to my advisor and instructor Dr. Fesseha Kassahun for his unreserved guidance and assistance during the whole period of my research work. I would like to extend my appreciation to the Abdus Salam International Center for Theoretical Physics (ICTP) for the financial support I have received during my M. Sc. study. I would also like to acknowledge the Department of Physics and School of Graduate Studies of Addis Ababa University for all co-operation I had during my M. Sc. study.

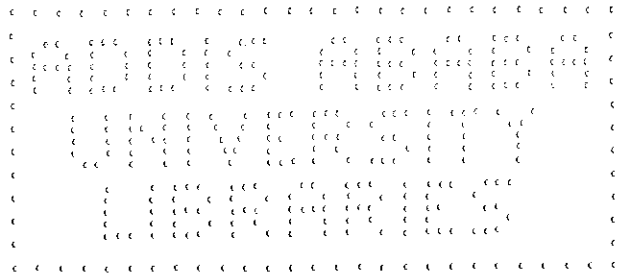

CONTENTS

1. INTRODUCTION	1
2. COHERENTLY PREPARED DEGENERATE THREE-LEVEL LASER	3
2.1. The Master Equation	3
2.2. Quadrature Variance	10
2.3. Squeezing Spectrum	14
2.4. Photon Statistics	16
A. The variance of the photon number	16
B. The photon number distribution	18
3. COHERENTLY PREPARED NONDEGENERATE THREE-LEVEL LASER	22
3.1. The Master Equation	22
3.2. Quadrature Variance	29
3.3. Squeezing Spectrum	31
3.4. Photon Statistics	36
A. The variances of the photon number	36
B. The photon number distribution	40
4. CONCLUSION	45
References	46

1. INTRODUCTION

In 1954, Gordon, Zeiger, and Townes showed that coherent electromagnetic radiation can be generated in the radio frequency range by the so-called maser (microwave amplification by stimulated emission of radiation) [1]. The maser principle was extended for the first time by Schawlow and Townes, and also by Prokhorov, to the optical domain, thus obtaining a laser (light amplification by stimulated emission of radiation) [2,3]. A laser consists of a set of atoms interacting with a resonant electromagnetic radiation inside a cavity with a single port-mirror. A laser operating well above threshold generates coherent light.

Squeezed light is generated when the quantum noise in one quadrature is suppressed below the vacuum level at the expense of enhanced fluctuations in the conjugate quadrature, with the product of the variance in the two quadratures satisfying the uncertainty relation [4-8]. Squeezing is a nonclassical feature of light. A degenerate parametric oscillator is a typical source of squeezed light [9-13]. It is also worth mentioning that squeezed light has important applications in low-noise communication and weak-signal detection [14,15].

A coherently prepared three-level laser is defined as a quantum optical system in which three-level atoms in a cascade configuration and initially prepared in a coherent superposition of the top and bottom levels are injected at a certain rate into a cavity coupled to a vacuum reservoir via a single-port mirror. We denote the top, middle, and bottom levels by $|a\rangle$, $|b\rangle$, and $|c\rangle$, respectively. In addition, we assume the cavity mode to be at resonance with the two transitions $|a\rangle \rightarrow |b\rangle$ and $|b\rangle \rightarrow |c\rangle$, with direct transition between levels $|a\rangle$ and $|c\rangle$ to be dipole forbidden. It has been found that a degenerate three-level laser produces under certain conditions squeezed light [16-18].

The aim of this thesis is to analyze the squeezing and statistical properties of coherently

prepared degenerate and nondegenerate three-level lasers. We consider a three-level laser in which atomic coherence is introduced by preparing the atoms to be initially in a coherent superposition of the top and the bottom levels. The transition from the top level to the middle level and then to the bottom level produces two photons of the same frequency in a degenerate three-level laser. Whereas in a nondegenerate three-level laser the transition from the top level to the bottom level via the intermediate level results in the generation of two photons of different frequencies.

In this thesis, we first derive, applying the method used in ref. [19], the master equation for the cavity radiation of the degenerate and nondegenerate three-level lasers. Then employing the master equation, we obtain the equations of evolution for the first and second order moments of the cavity mode operators. With the aid of the steady state solutions of the resulting equations, we calculate the quadrature variance, the mean photon number, and the variance of the photon number. We also calculate, using the time dependent solutions, the squeezing spectrum. Moreover, applying the steady state solutions, we determine the antinormally ordered characteristic function [19] with the aid of which the Q function is obtained. Finally the Q function is used to calculate the photon number distribution [13].

2. A COHERENTLY PREPARED DEGENERATE THREE-LEVEL LASER

A coherently prepared degenerate three-level laser is defined as a quantum optical system in which three-level atoms in cascade configuration and initially prepared in a coherent superposition of the top and bottom levels are injected at a certain rate into a cavity coupled to a vacuum reservoir via a single-port mirror. An atom emits two photons of the same frequency as it makes a transition from the top level to the middle level and then to the bottom level. Such a laser generates under certain conditions squeezed light [19].

In this chapter we wish to analyze the squeezing and statistical properties of a coherently prepared degenerate three-level laser. We first derive in the linear approximation and in the good-cavity limit the equation of evolution of the density operator for the cavity mode and with the help of this equation, we obtain the equations of evolution of first and second-order moments for the cavity mode operators. Then applying the steady-state solutions of the resulting equations, we calculate the quadrature variance, the squeezing spectrum and the variance of the photon number. Furthermore, employing the same solutions, we determine the antinormally ordered characteristic function with the aid of which the Q function is obtained. Finally the Q function is used to calculate the photon number distribution.

2.1 The Master Equation

A three-level laser consists of a cavity into which three-level atoms in a cascade configuration are injected at a constant rate r_a and removed from the cavity after a certain time τ . We denote the top, middle, and bottom levels by $|a\rangle$, $|b\rangle$, and $|c\rangle$, respectively. In

addition, we assume the cavity mode to be at resonance with the two transitions $|a\rangle \rightarrow |b\rangle$ and $|b\rangle \rightarrow |c\rangle$, with direct transition between levels $|a\rangle$ and $|c\rangle$ to be dipole forbidden.

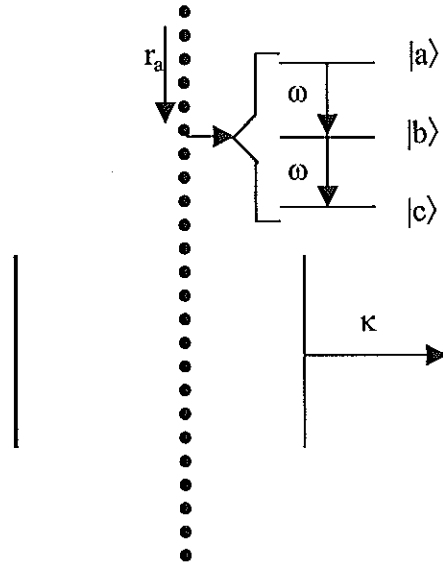

Fig. 2.1 A coherently prepared degenerate three-level laser.

The interaction of a three-level atom with the cavity mode can be described in the interaction picture and at resonance by the Hamiltonian

$$\hat{H} = ig[\hat{a}^\dagger(|b\rangle\langle a| + |c\rangle\langle b|) - \hat{a}(|a\rangle\langle b| + |b\rangle\langle c|)], \quad (2.1)$$

where g having the dimension of $\frac{1}{t}$ is the atom-radiation coupling constant taken to be equal for both transitions, and \hat{a} is the annihilation operator for the cavity mode. We take the initial state of a three-level atom to be

$$|\psi_A(0)\rangle = C_a(0)|a\rangle + C_c(0)|c\rangle \quad (2.2)$$

and hence the initial density operator for a single atom has the form

$$\hat{\rho}_A(0) = \rho_{aa}^{(0)}|a\rangle\langle a| + \rho_{ac}^{(0)}|a\rangle\langle c| + \rho_{ca}^{(0)}|c\rangle\langle a| + \rho_{cc}^{(0)}|c\rangle\langle c| \quad (2.3)$$

in which $\rho_{aa}^{(0)} = |C_a^{(0)}|^2$ and $\rho_{cc}^{(0)} = |C_c^{(0)}|^2$ are the probabilities for the atom to be initially in the upper and lower levels, respectively, and $\rho_{ac}^{(0)} = \rho_{ca}^{(0)*} = |\rho_{ac}^{(0)}|e^{i\theta}$ represents the initial coherence of the atom.

Suppose $\hat{\rho}_{AR}(t, t_j)$ is the density operator for a single atom plus the cavity mode at time t , with the atom injected at time t_j such that $(t - \tau) \leq t_j \leq t$. The density operator for all atoms in the cavity plus the cavity mode at time t can then be written as

$$\hat{\rho}_{AR}(t) = r_a \sum_j \hat{\rho}_{AR}(t, t_j) \Delta t, \quad (2.4)$$

where $r_a \Delta t$ represents the number of atoms injected into the cavity at time t_j . Now converting the summation into integration, we have

$$\hat{\rho}_{AR}(t) = r_a \int_{t-\tau}^t \hat{\rho}_{AR}(t, t') dt', \quad (2.5)$$

and on differentiating with respect to t , there follows

$$\frac{d}{dt} \hat{\rho}_{AR}(t) = r_a (\hat{\rho}_{AR}(t, t) - \hat{\rho}_{AR}(t, t - \tau)) + r_a \int_{t-\tau}^t \frac{\partial}{\partial t} \hat{\rho}_{AR}(t, t') dt'. \quad (2.6)$$

We notice that $\hat{\rho}_{AR}(t, t)$ is the density operator for the cavity mode plus an atom injected at time t . The cavity mode and the atom being injected are uncorrelated, so that this operator can be expressed as

$$\hat{\rho}_{AR}(t, t) = \hat{\rho}_A(0) \hat{\rho}(t), \quad (2.7)$$

with $\hat{\rho}(t)$ being the density operator for the cavity mode alone. We also observe that $\hat{\rho}_{AR}(t, t - \tau)$ represents the density operator for an atom plus the cavity mode at time

t, with the atom being removed from the cavity at this time. The cavity mode and the atom being removed are uncorrelated, so that this operator can also be put in the form

$$\hat{\rho}_{AR}(t, t - \tau) = \hat{\rho}_A(t - \tau)\hat{\rho}(t). \quad (2.8)$$

Now in view of (2.7) and (2.8), one can rewrite (2.6) as

$$\frac{d}{dt}\hat{\rho}_{AR}(t) = r_a (\hat{\rho}_A(0) - \hat{\rho}_A(t - \tau))\hat{\rho}(t) + r_a \int_{t-\tau}^t \frac{\partial}{\partial t'}\hat{\rho}_{AR}(t, t')dt'. \quad (2.9)$$

In the absence of dissipation the density operator $\hat{\rho}_{AR}(t, t')$ evolves in time according to

$$\frac{\partial}{\partial t'}\hat{\rho}_{AR}(t, t') = -i[\hat{H}, \hat{\rho}_{AR}(t, t')], \quad (2.10)$$

and hence using this, (2.9) can be rewritten as

$$\frac{d}{dt}\hat{\rho}_{AR}(t) = r_a (\hat{\rho}_A(0) - \hat{\rho}_A(t - \tau))\hat{\rho}(t) - ir_a \int_{t-\tau}^t [\hat{H}, \hat{\rho}_{AR}(t, t')]dt'. \quad (2.11)$$

Taking into account (2.5), one can put Eq.(2.11) in the form

$$\frac{d}{dt}\hat{\rho}_{AR}(t) = r_a (\hat{\rho}_A(0) - \hat{\rho}_A(t - \tau))\hat{\rho}(t) - i[\hat{H}, \hat{\rho}_{AR}(t)]. \quad (2.12)$$

Furthermore, tracing over the atomic variables and taking into account the damping of the cavity mode by a vacuum reservoir, we get

$$\begin{aligned} \frac{d}{dt}\hat{\rho} &= r_a Tr_A (\hat{\rho}_A(0) - \hat{\rho}_A(t - \tau))\hat{\rho}(t) - iTr_A[\hat{H}, \hat{\rho}_{AR}(t)] \\ &\quad + \frac{1}{2}\kappa(2\hat{a}\hat{\rho}\hat{a}^\dagger - \hat{\rho}\hat{a}^\dagger\hat{a} - \hat{a}^\dagger\hat{a}\hat{\rho}), \end{aligned} \quad (2.13)$$

where κ is the cavity damping constant.

Since

$$Tr\hat{\rho}_A(0) = Tr\hat{\rho}_A(t - \tau) = 1, \quad (2.14)$$

we see that Eq.(2.13) reduces to

$$\frac{d}{dt}\hat{\rho} = -iTr_A[\hat{H}, \hat{\rho}_{AR}(t)] + \frac{1}{2}\kappa(2\hat{a}\hat{\rho}\hat{a}^\dagger - \hat{\rho}\hat{a}^\dagger\hat{a} - \hat{a}^\dagger\hat{a}\hat{\rho}). \quad (2.15)$$

Employing (2.1) and applying the cyclic property of the trace operation, the master equation for the cavity mode can be put in the form

$$\begin{aligned} \frac{d}{dt}\hat{\rho} = & g(\hat{a}^\dagger\hat{\rho}_{ab} - \hat{\rho}_{ab}\hat{a}^\dagger + \hat{a}^\dagger\hat{\rho}_{bc} - \hat{\rho}_{bc}\hat{a}^\dagger + \hat{\rho}_{ba}\hat{a} - \hat{a}\hat{\rho}_{ba} + \hat{\rho}_{cb}\hat{a} - \hat{a}\hat{\rho}_{cb}) \\ & + \frac{1}{2}\kappa(2\hat{a}\hat{\rho}\hat{a}^\dagger - \hat{\rho}\hat{a}^\dagger\hat{a} - \hat{a}^\dagger\hat{a}\hat{\rho}), \end{aligned} \quad (2.16)$$

where $\hat{\rho}_{\alpha\beta}$ is defined by

$$\hat{\rho}_{\alpha\beta} = \langle\alpha|\hat{\rho}_{AR}|\beta\rangle, \quad (2.17)$$

with $\alpha, \beta = a, b, c$. On the other hand, we observe from (2.12) that

$$\frac{d}{dt}\hat{\rho}_{\alpha\beta} = r_a(\langle\alpha|\hat{\rho}_A(0)|\beta\rangle - \langle\alpha|\hat{\rho}_A(t-\tau)|\beta\rangle)\hat{\rho}(t) - i(\langle\alpha|\hat{H}\hat{\rho}_{AR}|\beta\rangle - \langle\alpha|\hat{\rho}_{AR}\hat{H}|\beta\rangle) - \gamma\hat{\rho}_{\alpha\beta}, \quad (2.18)$$

where the last term included to account for the decay of atoms due to spontaneous emission. And γ , considered to be the same for all the three levels, is the atomic decay rate.

We assume that the atoms are removed from the cavity after they have decayed to a level other than the middle or lower level. We then see that

$$\langle\alpha|\hat{\rho}_A(t-\tau)|\beta\rangle = 0, \quad (2.19)$$

and hence Eq.(2.18) reduces to

$$\frac{d}{dt}\hat{\rho}_{\alpha\beta} = r_a\langle\alpha|\hat{\rho}_A(0)|\beta\rangle\hat{\rho}(t) - i(\langle\alpha|\hat{H}\hat{\rho}_{AR}|\beta\rangle - \langle\alpha|\hat{\rho}_{AR}\hat{H}|\beta\rangle) - \gamma\hat{\rho}_{\alpha\beta}. \quad (2.20)$$

Applying this equation and taking into account (2.1) and (2.3), one readily obtains

$$\frac{d}{dt}\hat{\rho}_{ab} = g(\hat{\rho}_{aa}\hat{a} - \hat{a}\hat{\rho}_{bb} - \hat{\rho}_{ac}\hat{a}^\dagger) - \gamma\hat{\rho}_{ab}, \quad (2.21)$$

$$\frac{d}{dt}\hat{\rho}_{bc} = g(\hat{\rho}_{bb}\hat{a} + \hat{a}^\dagger\hat{\rho}_{ac} - \hat{a}\hat{\rho}_{cc}) - \gamma\hat{\rho}_{bc}, \quad (2.22)$$

$$\frac{d}{dt}\hat{\rho}_{aa} = r_a\rho_{aa}^{(0)}\hat{\rho} - g(\hat{\rho}_{ab}\hat{a}^\dagger + \hat{a}\hat{\rho}_{ba}) - \gamma\hat{\rho}_{aa}, \quad (2.23)$$

$$\frac{d}{dt}\hat{\rho}_{bb} = g(\hat{a}^\dagger\hat{\rho}_{ab} + \hat{\rho}_{ba}\hat{a} - \hat{\rho}_{bc}\hat{a}^\dagger - \hat{a}\hat{\rho}_{cb}) - \gamma\hat{\rho}_{bb}, \quad (2.24)$$

$$\frac{d}{dt}\hat{\rho}_{ac} = r_a\rho_{ac}^{(0)}\hat{\rho} + g(\hat{\rho}_{ab}\hat{a} - \hat{a}\hat{\rho}_{bc}) - \gamma\hat{\rho}_{ac}, \quad (2.25)$$

$$\frac{d}{dt}\hat{\rho}_{cc} = r_a\rho_{cc}^{(0)}\hat{\rho} + g(\hat{a}^\dagger\hat{\rho}_{bc} + \hat{\rho}_{cb}\hat{a}) - \gamma\hat{\rho}_{cc}. \quad (2.26)$$

We carry out our analysis applying the linear and adiabatic approximation schemes. The linear approximation is achieved by dropping the g -terms in (2.23), (2.24), (2.25), and (2.26)

$$\frac{d}{dt}\hat{\rho}_{aa} = r_a\rho_{aa}^{(0)}\hat{\rho} - \gamma\hat{\rho}_{aa}, \quad (2.27)$$

$$\frac{d}{dt}\hat{\rho}_{bb} = -\gamma\hat{\rho}_{bb}, \quad (2.28)$$

$$\frac{d}{dt}\hat{\rho}_{ac} = r_a\rho_{ac}^{(0)}\hat{\rho} - \gamma\hat{\rho}_{ac}, \quad (2.29)$$

$$\frac{d}{dt}\hat{\rho}_{cc} = r_a\rho_{cc}^{(0)}\hat{\rho} - \gamma\hat{\rho}_{cc}. \quad (2.30)$$

In addition, we assume that $\kappa \ll g, \gamma$ (the good-cavity limit). Under this assumption, the cavity mode variables change slowly compared with the atomic variables. Since the atomic variables reach steady state in the relatively short period of γ^{-1} , one can take the time derivatives of such variables to be zero, while keeping the zero-order atomic and cavity mode variables at time t . This procedure may be referred to as the adiabatic approximation scheme. Thus upon applying the adiabatic approximation scheme, we get from Eqs. (2.27), (2.28), (2.29), and (2.30) that

$$\hat{\rho}_{aa} = \frac{r_a\rho_{aa}^{(0)}}{\gamma}\hat{\rho}, \quad (2.31)$$

$$\hat{\rho}_{bb} = 0, \quad (2.32)$$

$$\hat{\rho}_{ac} = \frac{r_a \rho_{ac}^{(0)}}{\gamma} \hat{\rho}, \quad (2.33)$$

$$\hat{\rho}_{cc} = \frac{r_a \rho_{cc}^{(0)}}{\gamma} \hat{\rho}. \quad (2.34)$$

Now combination of (2.21), (2.31), (2.32), and (2.33) as well as (2.22), (2.32), (2.33), and (2.34) leads to

$$\frac{d}{dt} \hat{\rho}_{ab} = \frac{gr_a}{\gamma} (\rho_{aa}^{(0)} \hat{\rho} \hat{a} - \rho_{ac}^{(0)} \hat{\rho} \hat{a}^\dagger) - \gamma \hat{\rho}_{ab}, \quad (2.35)$$

$$\frac{d}{dt} \hat{\rho}_{bc} = \frac{gr_a}{\gamma} (\rho_{ac}^{(0)} \hat{a}^\dagger \hat{\rho} - \rho_{cc}^{(0)} \hat{a} \hat{\rho}) - \gamma \hat{\rho}_{bc}. \quad (2.36)$$

Using once more the adiabatic approximation scheme, we easily find

$$\hat{\rho}_{ab} = \frac{gr_a}{\gamma^2} (\rho_{aa}^{(0)} \hat{\rho} \hat{a} - \rho_{ac}^{(0)} \hat{\rho} \hat{a}^\dagger), \quad (2.37)$$

$$\hat{\rho}_{bc} = \frac{gr_a}{\gamma^2} (\rho_{ac}^{(0)} \hat{a}^\dagger \hat{\rho} - \rho_{cc}^{(0)} \hat{a} \hat{\rho}). \quad (2.38)$$

Finally, on account of (2.37), (2.38), and (2.16), the equation of evolution of the density operator for the cavity mode takes the form

$$\begin{aligned} \frac{d}{dt} \hat{\rho} = & \frac{1}{2} A \rho_{aa}^{(0)} (2 \hat{a}^\dagger \hat{\rho} \hat{a} - \hat{\rho} \hat{a} \hat{a}^\dagger - \hat{a} \hat{a}^\dagger \hat{\rho}) + \frac{1}{2} (A \rho_{cc}^{(0)} + \kappa) (2 \hat{a} \hat{\rho} \hat{a}^\dagger - \hat{\rho} \hat{a}^\dagger \hat{a} - \hat{a}^\dagger \hat{a} \hat{\rho}) \\ & + \frac{1}{2} A \rho_{ac}^{(0)} (\hat{\rho} \hat{a}^{\dagger 2} + \hat{a}^{\dagger 2} \hat{\rho} - 2 \hat{a}^\dagger \hat{\rho} \hat{a}^\dagger) + \frac{1}{2} A \rho_{ca}^{(0)} (\hat{\rho} \hat{a}^2 + \hat{a}^2 \hat{\rho} - 2 \hat{a} \hat{\rho} \hat{a}), \end{aligned} \quad (2.39)$$

where

$$A = \frac{2r_a g^2}{\gamma^2} \quad (2.40)$$

is the linear gain coefficient.

It is worth mentioning that the quantum properties of the light generated by degenerate three-level laser are determined by the master equation (2.39). It is not hard to see that with $\rho_{ac}^{(0)} = \rho_{cc}^{(0)} = 0$ and $\rho_{aa}^{(0)} = 1$, this equation goes over to the master equation of a two-level laser operating below threshold. The term involving $\rho_{aa}^{(0)}$ corresponds to the usual gain and that proportional to $\rho_{cc}^{(0)}$, to absorption. We will see that the atomic

coherence $\rho_{ac}^{(0)}$ as well as $\rho_{ca}^{(0)}$ is responsible for squeezing. The term involving κ represents cavity losses.

2.2 Quadrature Variance

We next seek to determine the quadrature variance of the cavity mode. The equation of evolution for the cavity mode operator \hat{a} is expressible as

$$\frac{d}{dt}\langle\hat{a}(t)\rangle = Tr\left(\frac{d\hat{\rho}}{dt}\hat{a}\right), \quad (2.41)$$

with the aid of Eq.(2.39) and employing the comutation relations

$$[\hat{a}, f(\hat{a}^\dagger, \hat{a})] = \frac{\partial}{\partial \hat{a}^\dagger} f(\hat{a}^\dagger, \hat{a}) \quad (2.42)$$

and

$$[\hat{a}^\dagger, f(\hat{a}^\dagger, \hat{a})] = -\frac{\partial}{\partial \hat{a}} f(\hat{a}^\dagger, \hat{a}). \quad (2.43)$$

Eq.(2.41) can be expressed as

$$\frac{d}{dt}\langle\hat{a}(t)\rangle = -\frac{1}{2}\mu\langle\hat{a}(t)\rangle. \quad (2.44)$$

In the same way one can readily obtain that

$$\frac{d}{dt}\langle\hat{a}^2(t)\rangle = -\mu\langle\hat{a}^2(t)\rangle + A\rho_{ac}^{(0)}, \quad (2.45)$$

$$\frac{d}{dt}\langle\hat{a}^\dagger(t)\hat{a}(t)\rangle = -\mu\langle\hat{a}^\dagger(t)\hat{a}(t)\rangle + A\rho_{aa}^{(0)}, \quad (2.46)$$

in which

$$\mu = \kappa - A(\rho_{aa}^{(0)} - \rho_{cc}^{(0)}). \quad (2.47)$$

In veiw of (2.44), (2.45), and (2.46) the steady-state solutions of the first and second-order moments become

$$\langle\hat{a}(t)\rangle_{ss} = 0, \quad (2.48)$$

$$\langle \hat{a}^2(t) \rangle_{ss} = \frac{A}{\mu} \rho_{ac}^{(0)}, \quad (2.49)$$

$$\langle \hat{a}^\dagger(t) \hat{a}(t) \rangle_{ss} = \frac{A}{\mu} \rho_{aa}^{(0)}. \quad (2.50)$$

The variance of the quadrature operators

$$\hat{a}_+ = \hat{a}^\dagger + \hat{a} \quad (2.51)$$

and

$$\hat{a}_- = i(\hat{a}^\dagger - \hat{a}) \quad (2.52)$$

can be written as

$$\Delta a_\pm^2 = \langle \hat{a}_\pm^2 \rangle - \langle \hat{a}_\pm \rangle^2, \quad (2.53)$$

where the + and - refer to the unsqueezed and squeezed quadratures, respectively.

These operators are Hermitian and satisfying the commutation relation

$$[\hat{a}_+, \hat{a}_-] = 2i. \quad (2.54)$$

Applying (2.48) along with (2.51) and (2.52)

$$\langle \hat{a}_\pm \rangle = 0. \quad (2.55)$$

So that Eq.(2.53) reduces to

$$\Delta a_\pm^2 = \langle \hat{a}_\pm^2 \rangle. \quad (2.56)$$

On account of the commutation relation

$$[\hat{a}, \hat{a}^\dagger] = 1, \quad (2.57)$$

we can express Eq.(2.56) in the normal ordering

$$\Delta a_\pm^2 = 1 + \langle : \hat{a}_\pm^2(t) : \rangle, \quad (2.58)$$

where $::$ denotes normal ordering.

With the aid of the definitions (2.51) and (2.52), the expectation value of the squares of the quadrature operators in normal order is

$$\langle : \hat{a}_{\pm}^2(t) : \rangle = \pm[\langle \hat{a}^{\dagger 2}(t) \rangle + \langle \hat{a}^2(t) \rangle \pm 2\langle \hat{a}^{\dagger}(t)\hat{a}(t) \rangle] \quad (2.59)$$

Applying the results (2.50), (2.49) and its complex conjugate, one finds at steady state

$$\langle : \hat{a}_{\pm}^2(t) : \rangle = \pm[A(\rho_{ac}^{(0)} + \rho_{ca}^{(0)} \pm 2\rho_{aa}^{(0)})/\mu]. \quad (2.60)$$

It proves to be more convenient to introduce a new parameter defined by

$$\rho_{aa}^{(0)} = \frac{1 - \eta}{2}, \quad (2.61)$$

so that in view of the fact that

$$\rho_{aa}^{(0)} + \rho_{cc}^{(0)} = 1 \quad (2.62)$$

and

$$|\rho_{ac}^{(0)}|^2 = \rho_{aa}^{(0)}\rho_{cc}^{(0)}, \quad (2.63)$$

one easily finds

$$\rho_{cc}^{(0)} = \frac{1 + \eta}{2} \quad (2.64)$$

and

$$|\rho_{ac}^{(0)}| = \frac{1}{2}(1 - \eta^2)^{\frac{1}{2}}. \quad (2.65)$$

Upon setting

$$\rho_{ac}^{(0)} = |\rho_{ac}^{(0)}|e^{i\theta} \quad (2.66)$$

and taking into account (2.47), expression (2.60) can then be rewritten as

$$\langle : \hat{a}_{\pm}^2(t) : \rangle = \pm \frac{A \left((1 - \eta^2)^{\frac{1}{2}} \cos\theta \pm (1 - \eta) \right)}{A\eta + \kappa}. \quad (2.67)$$

Now combination of (2.58) and (2.67) yields at steady state

$$\Delta a_{\pm}^2 = \frac{\kappa + A(1 \pm (1 - \eta^2)^{\frac{1}{2}} \cos\theta)}{A\eta + \kappa} \quad (2.68)$$

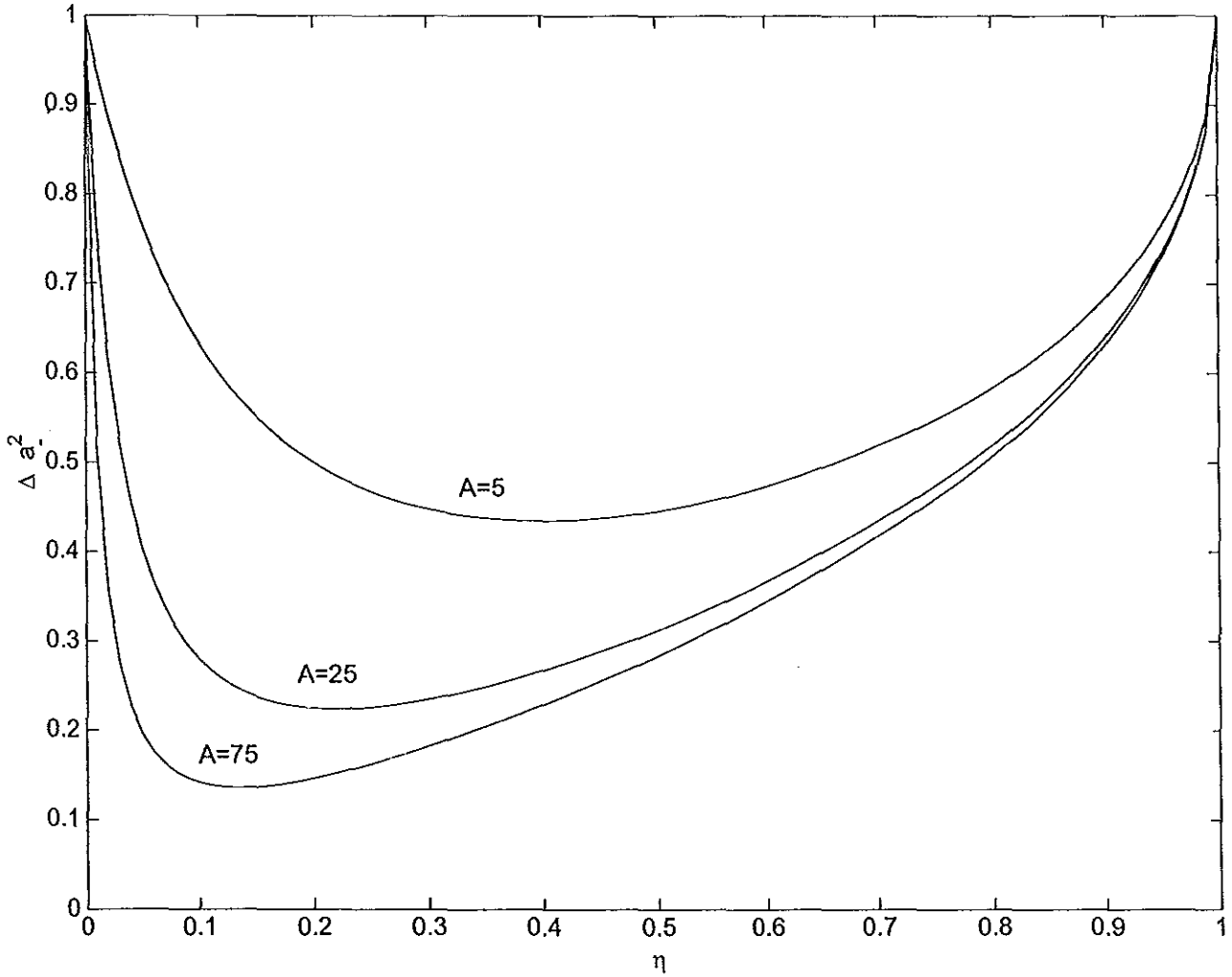

Fig.2.2 plots of the quadrature variance Δa_{\pm}^2 versus η for $\kappa=0.8$, $\theta=0$, and for different linear gain coefficient.

We see from Fig. 2.2 that the cavity mode is in a squeezed state for all values of η between zero and one and the degree of squeezing increases as the linear gain coefficient increases. It also appears that almost perfect squeezing can be achieved for sufficiently large values of the linear gain coefficient.

2.3 Squeezing Spectrum

We now proceed to calculate the squeezing spectrum of the cavity mode. The squeezing spectrum of a single-mode light can be expressed as

$$S_{\pm}^{out}(\omega) = 1 + 2Re \int_0^{\infty} \langle : \hat{a}_{\pm}^{out}(t), \hat{a}_{\pm}^{out}(t + \tau) : \rangle_{ss} e^{i\omega\tau} d\tau, \quad (2.69)$$

where

$$\hat{a}_{+}^{out}(t) = \hat{a}_{out}^{\dagger}(t) + \hat{a}_{out}(t), \quad (2.70)$$

$$\hat{a}_{-}^{out}(t) = i(\hat{a}_{out}^{\dagger}(t) - \hat{a}_{out}(t)). \quad (2.71)$$

We note that for a cavity mode coupled to a vacuum reservoir, the output and intracavity variables are related by [19]

$$\hat{a}_{\pm}^{out}(t) = \sqrt{\kappa} \hat{a}_{\pm}(t). \quad (2.72)$$

In view of (2.72), the squeezing spectrum expressed in terms of intracavity variables as

$$S_{\pm}^{out}(\omega) = 1 + 2\kappa Re \int_0^{\infty} \langle : \hat{a}_{\pm}(t), \hat{a}_{\pm}(t + \tau) : \rangle_{ss} e^{i\omega\tau} d\tau, \quad (2.73)$$

where

$$\langle \hat{a}_{\pm}(t) \hat{a}_{\pm}(t + \tau) \rangle = \langle \hat{a}_{\pm}(t) \hat{a}_{\pm}(t + \tau) \rangle - \langle \hat{a}_{\pm}(t) \rangle \langle \hat{a}_{\pm}(t + \tau) \rangle. \quad (2.74)$$

Therefore, on account of (2.74) and (2.55), the squeezing spectrum can be put in the form

$$S_{\pm}^{out}(\omega) = 1 + 2\kappa Re \int_0^{\infty} \langle : \hat{a}_{\pm}(t) \hat{a}_{\pm}(t + \tau) : \rangle_{ss} e^{i\omega\tau} d\tau. \quad (2.75)$$

To this end, we note that the time-dependent solution of Eq.(2.44) can be written as

$$\langle \hat{a}(t + \tau) \rangle = \langle \hat{a}(t) \rangle e^{-\frac{\kappa}{2}\tau}. \quad (2.76)$$

Furthermore, on account of (2.76) together with (2.51) and (2.52), we note that

$$\langle \hat{a}_{\pm}(t + \tau) \rangle = \langle \hat{a}_{\pm}(t) \rangle e^{-\frac{\kappa}{2}\tau}, \quad (2.77)$$

and application of the quantum regration theorem leads to

$$\langle : \hat{a}_{\pm}(t)\hat{a}_{\pm}(t+\tau) : \rangle = \langle : \hat{a}_{\pm}(t)\hat{a}_{\pm}(t) : \rangle e^{-\frac{\kappa}{2}\tau}. \quad (2.78)$$

Now upon substituting (2.78) into (2.75) and taking into account (2.67), we readily obtain

$$S_{\pm}^{out}(\omega) = 1 \pm \frac{\kappa A \left((1-\eta^2)^{\frac{1}{2}} \cos\theta \pm (1-\eta) \right)}{\omega^2 + [(A\eta + \kappa)/2]^2}. \quad (2.79)$$

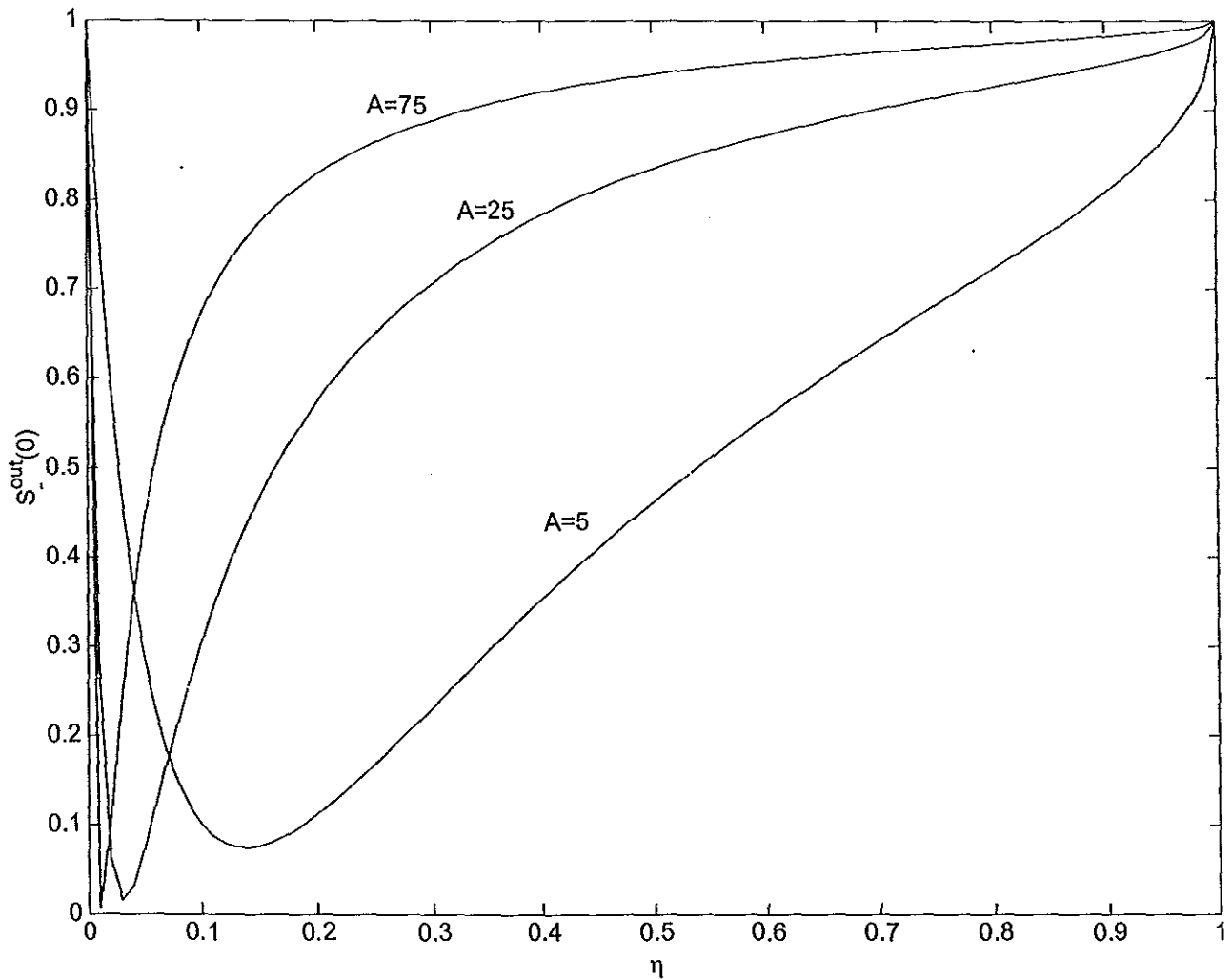

Fig.2.3 plots of the squeezing spectrum $S_{-}^{out}(0)$ versus η for $\kappa=0.8$, $\theta=0$, and for different linear gain coefficient.

In Fig. 2.3 we see that, at $\omega=0$ there is perfect squeezing for a sufficiently large values of A (linear gain coefficient) for a value of η very close to zero.

2.4 Photon Statistics

In this section we seek to calculate the variance of the photon number and the photon number distribution, at steady state, for a degenerate three-level laser coupled to ordinary vacuum.

A. The variance of the photon number

The variance of the photon number is expressible as

$$\Delta n^2 = \langle \hat{n}^2 \rangle - \langle \hat{n} \rangle^2, \quad (2.80)$$

where

$$\hat{n} = \hat{a}^\dagger(t)\hat{a}(t) \quad (2.81)$$

is the photon number of the cavity mode at any time t .

Using the commutation relation

$$[\hat{a}, \hat{a}^\dagger] = 1, \quad (2.82)$$

one can rewrite Eq.(2.80) as

$$\Delta n^2 = \bar{n} + \langle \hat{a}^{\dagger 2}(t)\hat{a}^2(t) \rangle_{ss} - \bar{n}^2. \quad (2.83)$$

In view of (2.50), the mean photon number at steady state is

$$\langle \hat{a}^\dagger(t)\hat{a}(t) \rangle_{ss} = \frac{A}{\mu} \rho_{aa}^{(0)}, \quad (2.84)$$

in terms of the parameter η the mean photon number at steady state is given by

$$\bar{n} = \frac{A(1 - \eta)}{2(A\eta + \kappa)}. \quad (2.85)$$

Furthermore, since the cavity mode operator $\hat{a}(t)$ at steady state is a Gaussian random variable [19], i.e., has a vanishing mean, one can rewrite (2.83) as

$$\Delta n^2 = \bar{n} + \bar{n}^2 + \langle \hat{a}^{\dagger 2}(t) \rangle_{ss} \langle \hat{a}^2(t) \rangle_{ss}, \quad (2.86)$$

so that in view of (2.49) and its complex conjugate, the photon number variance found to be

$$\Delta n^2 = \bar{n} + \bar{n}^2 + \frac{A^2}{\mu^2} |\rho_{ac}^{(0)}|^2, \quad (2.87)$$

in terms of η the photon number variance can be put in the form

$$\Delta n^2 = \bar{n} + \bar{n}^2 + \frac{A^2(1 - \eta^2)}{4(A\eta + \kappa)^2} \quad (2.88)$$

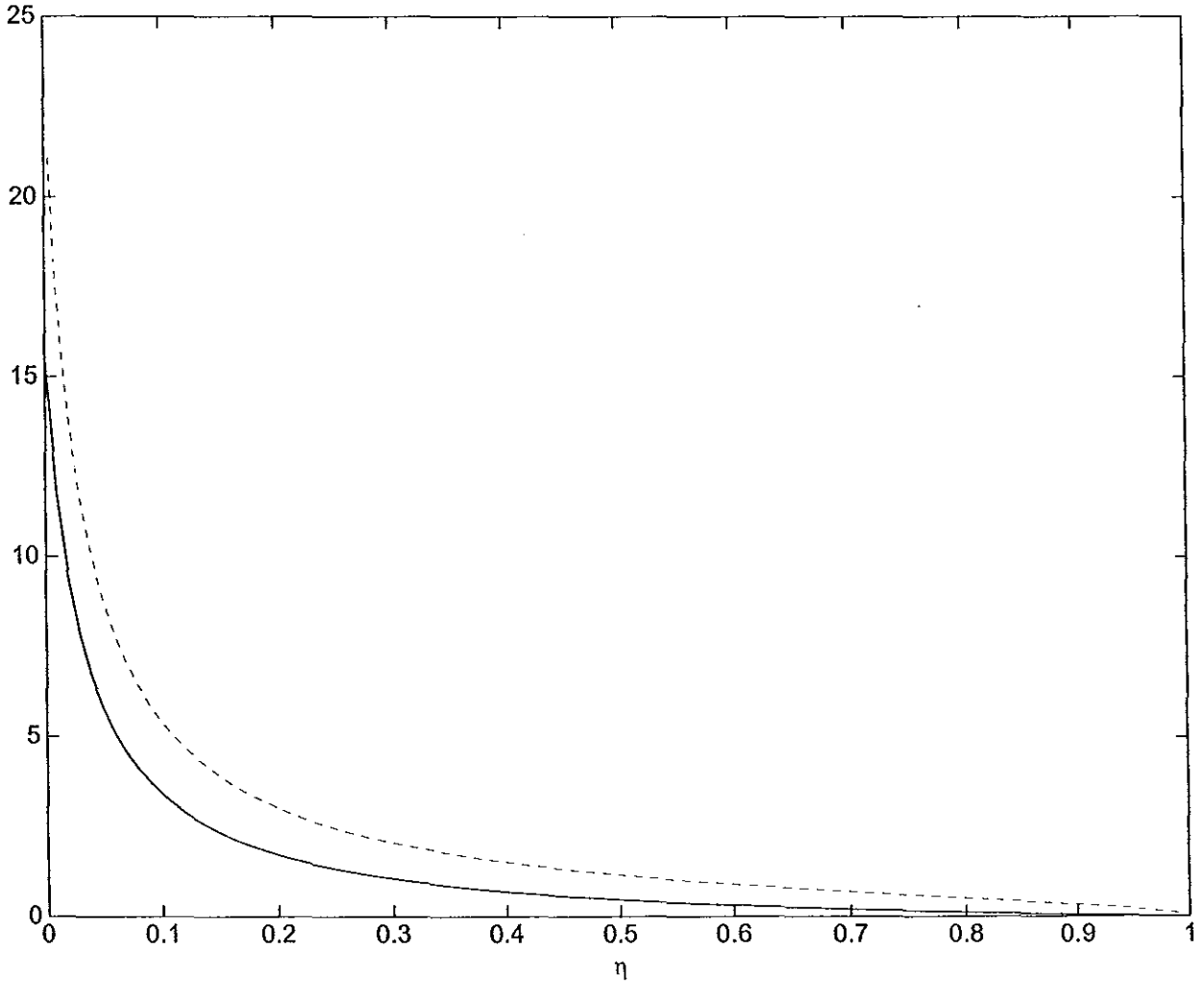

Fig. 2.4 Plots of the mean photon number \bar{n} (solid curve) and the uncertainty in the

photon number Δn (dotted curve) versus η for $A=25$ and for $\kappa=0.8$.

Fig. 2.4 clearly indicates that both the mean photon number and the uncertainty in the photon number decreases with η .

B. The Photon Number Distribution

Finally, we proceed to calculate the photon number distribution employing the Q function.

The Q function for a single-mode light is expressible as [19]

$$Q(\alpha^*, \alpha) = \frac{1}{\pi^2} \int d^2z \Phi(z^*, z) \exp(z^* \alpha - z \alpha^*), \quad (2.89)$$

where the antinormally ordered characteristic function in the Heisenberg picture is expressed as [19]

$$\Phi(z^*, z) = \text{Tr} \left(\hat{\rho}(0) e^{-z^* \hat{a}(t)} e^{z \hat{a}^\dagger(t)} \right) \quad (2.90)$$

here $\hat{\rho}(0)$ is the density operator for the cavity mode and the reservoir at the initial time.

To this end, applying the identity

$$e^A e^B = e^{A+B+\frac{1}{2}[A,B]}, \quad (2.91)$$

one can express the characteristic function (2.90) as

$$\begin{aligned} \Phi(z^*, z) &= e^{-\frac{1}{2}z^*z} \text{Tr} \left(\hat{\rho}(0) \exp(z \hat{a}^\dagger - z^* \hat{a}) \right) \\ &= e^{-\frac{1}{2}z^*z} \langle \exp(z \hat{a}^\dagger - z^* \hat{a}) \rangle, \end{aligned} \quad (2.92)$$

and hence on account of the fact that \hat{a} at steady state is a Gaussian random variable [19], we have

$$\Phi(z^*, z) = e^{-\frac{1}{2}z^*z} \exp \left(\frac{1}{2} \langle [z \hat{a}^\dagger - z^* \hat{a}]^2 \rangle_{ss} \right), \quad (2.93)$$

squaring the expression in the bracket and applying the commutation relation (2.82)

Eq.(2.93) can be put in the form

$$\Phi(z^*, z) = e^{-z^*z} \exp\left(\frac{1}{2}([z^2 \hat{a}^{\dagger 2} + z^{*2} \hat{a}^2 - 2z^* z \hat{a}^\dagger \hat{a}])_{ss}\right). \quad (2.94)$$

Next introducing the steady state expectation values of \hat{a}^2 , $\hat{a}^{\dagger 2}$, and $\hat{a}^\dagger \hat{a}$ from (2.49) and (2.50) into (2.94), the characteristic function can be written as

$$\Phi(z^*, z) = \exp[-az^*z + (bz^2 + b^*z^{*2})/2], \quad (2.95)$$

where the coefficients have in terms of the parameter η the form

$$a = 1 + \frac{A(1 - \eta)}{2(A\eta + \kappa)}, \quad (2.96)$$

$$b = \frac{A(1 - \eta^2)^{\frac{1}{2}}}{2(A\eta + \kappa)} e^{-i\theta}. \quad (2.97)$$

Furthermore substituting (2.95) into (2.89), the Q function can be written as

$$Q(\alpha^*, \alpha) = \frac{1}{\pi^2} \int d^2z \exp[-az^*z + (bz^2 + b^*z^{*2})/2 + z^*\alpha - z\alpha^*]. \quad (2.98)$$

Therefore, performing the integration over z , the Q function for the cavity mode is found at steady state to be

$$Q(\alpha^*, \alpha) = \frac{[u^2 - vv^*]^{\frac{1}{2}}}{\pi} \exp[-u\alpha^*\alpha + (v\alpha^2 + v^*\alpha^{*2})/2], \quad (2.99)$$

where

$$u = \frac{a}{a^2 - bb^*}, \quad (2.100)$$

$$v = \frac{b}{a^2 - bb^*}. \quad (2.101)$$

The photon number distribution for a single-mode light at steady state, can be expressed in terms of the Q function as [13]

$$P(n) = \frac{\pi}{n!} \frac{\partial^{2n}}{\partial \alpha^n \partial \alpha^{*n}} [Q(\alpha^*, \alpha) e^{\alpha^* \alpha}]_{\alpha^* = \alpha = 0}. \quad (2.102)$$

Now applying (2.99) along with (2.102), the photon number distribution for the cavity mode takes the form

$$P(n) = \frac{1}{n!} [u^2 - vv^*]^{\frac{1}{2}} \frac{\partial^{2n}}{\partial \alpha^{*n} \partial \alpha^n} \exp[(1-u)\alpha^* \alpha + (v^* \alpha^{*2} + v \alpha^2)/2]_{\alpha^* = \alpha = 0}. \quad (2.103)$$

Hence expanding the exponential functions in power series, we have

$$P(n) = \frac{1}{n!} [u^2 - vv^*]^{\frac{1}{2}} \sum_{klm} \frac{(1-u)^k v^{*l} v^m}{2^{l+m} k! l! m!} \frac{\partial^{2n}}{\partial \alpha^{*n} \partial \alpha^n} [(\alpha^*)^{k+2l} \alpha^{k+2m}]_{\alpha^* = \alpha = 0}, \quad (2.104)$$

and in view of the fact that

$$\frac{\partial^n}{\partial x^n} x^p = \frac{p!}{(p-n)!} x^{p-n}, \quad (2.105)$$

we find

$$P(n) = \frac{1}{n!} [u^2 - vv^*]^{\frac{1}{2}} \sum_{klm} \frac{(1-u)^k v^{*l} v^m}{2^{l+m} k! l! m!} \frac{(k+2l)!(k+2m)!}{(k+2l-n)!(k+2m-n)!} \times [(\alpha^*)^{k+2l-n} \alpha^{k+2m-n}]_{\alpha^* = \alpha = 0}. \quad (2.106)$$

Applying the condition $\alpha = \alpha^* = 0$, it then follows

$$P(n) = \frac{1}{n!} [u^2 - vv^*]^{\frac{1}{2}} \sum_{klm} \frac{(1-u)^k v^{*l} v^m}{2^{l+m} k! l! m!} \frac{(k+2l)!(k+2m)!}{(k+2l-n)!(k+2m-n)!} \delta_{k+2l,n} \delta_{k+2m,n}. \quad (2.107)$$

From the property of the kronecker delta, we see that

$$k + 2l = n \quad (2.108)$$

and

$$k + 2m = n, \quad (2.109)$$

this implies

$$l = m \quad (2.110)$$

Finally, on account of the result $m = l$ and $k = n - 2l$, the photon number distribution takes the form

$$P(n) = [u^2 - vv^*]^{\frac{1}{2}} \sum_{l=0}^{\lfloor n/2 \rfloor} \frac{n!(1-u)^{n-2l}(vv^*)^l}{2^{2l}l!(n-2l)!}, \quad (2.111)$$

where $\lfloor n \rfloor = n/2$ for even n and $\lfloor n \rfloor = (n-1)/2$ for odd n . This distribution function has the same form as the one for the signal mode from a degenerate parametric oscillator. We see from Fig. 2.5 that the probability to find an even number of photons is greater than the probability to find an odd number of photons. This is due to the fact that the photons are always generated in pairs and the existence of some finite probability to find an odd number of photons is due to damping of the cavity mode.

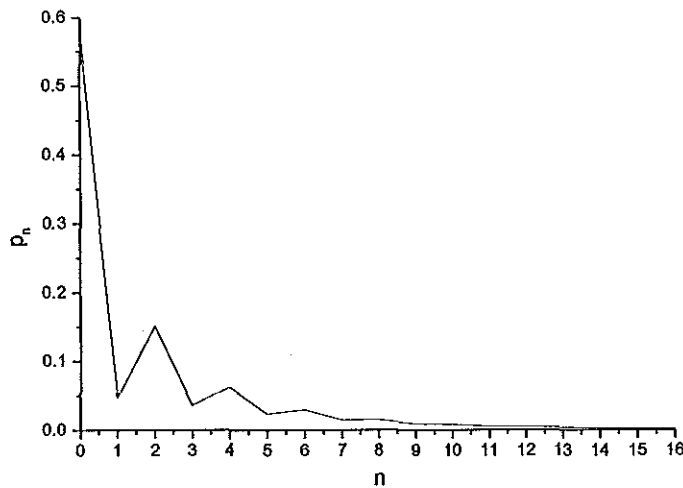

Fig. 2.5 photon number distribution p_n versus number of photons n for $A=25$, $\kappa=0.8$, $\theta=0$, and $\eta=0.2$.

3. A COHERENTLY PREPARED NONDEGENERATE THREE-LEVEL LASER

We consider here a three-level atom in a cascade configuration and initially prepared in a superposition of the top and bottom levels. We assume that such an atom emits two photons of different frequencies as it makes a transition from the top level to the intermediate level and then to the bottom level. We define a nondegenerate three-level laser as an optical system into which three-level atoms (described above) are injected at a constant rate r_a into a cavity coupled to an ordinary vacuum via a single port mirror. The atoms are removed from the cavity after time τ .

In this chapter, we first derive in the linear approximation and in the good-cavity limit the master equation for the light generated by a nondegenerate three-level laser. Then using the resulting equation, we obtain the equations of evolution for the first and second order moments of the radiation operators. With the aid of the steady-state solutions of these equations, we calculate the quadrature variance, the squeezing spectrum and the variance of the photon numbers. Furthermore, applying the same solutions, we determine the antinormally ordered characteristic function with the aid of which the Q function is obtained. Finally the Q function is employed to calculate the photon number distribution.

3.1 The Master Equation

The interaction of a three-level atom with the cavity mode can be described in the interaction picture by the Hamiltonian

$$\hat{H} = ig[\hat{a}^\dagger|b\rangle\langle a| - \hat{a}|a\rangle\langle b| + \hat{b}^\dagger|c\rangle\langle b| - \hat{b}|b\rangle\langle c|], \quad (3.1)$$

where g is the atom-radiation coupling constant which is taken to be equal for both transitions and $\hat{a}(\hat{b})$ are the annihilation operators for the two modes of the cavity.

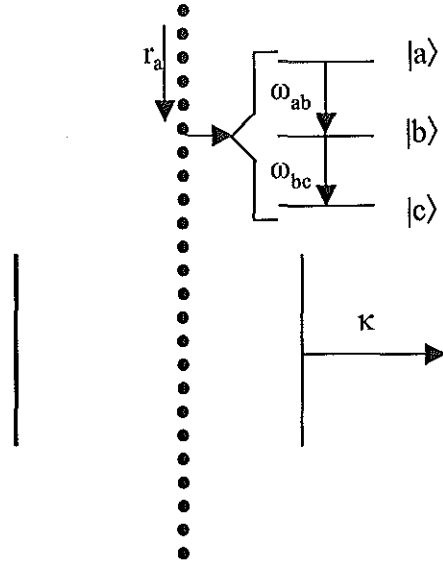

Fig. 3.1 A coherently prepared nondegenerate three-level laser

We take the initial state of a three-level atom to be

$$|\psi_A(0)\rangle = C_a(0)|a\rangle + C_c(0)|c\rangle, \quad (3.2)$$

where $C_a(0)$ and $C_c(0)$ are the probability amplitudes for the atoms to be in levels $|a\rangle$ and $|c\rangle$, respectively. And hence the initial density operator for a single atom becomes

$$\hat{\rho}_A(0) = \rho_{aa}^{(0)}|a\rangle\langle a| + \rho_{ac}^{(0)}|a\rangle\langle c| + \rho_{ca}^{(0)}|c\rangle\langle a| + \rho_{cc}^{(0)}|c\rangle\langle c|, \quad (3.3)$$

where $\rho_{aa}^{(0)} = |C_a|^2$, $\rho_{cc}^{(0)} = |C_c|^2$, and $\rho_{ac}^{(0)} = C_a C_c^*$. The density operator for all atoms in the cavity plus the cavity modes at time t can be expressed as

$$\hat{\rho}_{AR}(t) = r_a \sum_j \hat{\rho}_{AR}(t, t_j) \Delta t, \quad (3.4)$$

where $r_a \Delta t$ is the number of atoms injected into the cavity at time t_j . Converting the

summation into integration, we get

$$\hat{\rho}_{AR}(t) = r_a \int_{t-\tau}^t \hat{\rho}_{AR}(t, t'), \quad (3.5)$$

and differentiating with respect to t , we obtain

$$\frac{d}{dt} \hat{\rho}_{AR}(t) = r_a (\hat{\rho}_{AR}(t, t) - \hat{\rho}_{AR}(t, t - \tau)) + r_a \int_{t-\tau}^t \frac{\partial}{\partial t} \hat{\rho}_{AR}(t, t') dt'. \quad (3.6)$$

We note that $\hat{\rho}_{AR}(t, t)$ is the density operator for the cavity modes plus an atom injected at time t . Thus it can be expressed as

$$\hat{\rho}_{AR}(t, t) = \hat{\rho}_A(0) \hat{\rho}(t), \quad (3.7)$$

in which $\hat{\rho}(t)$ is the density operator for the cavity modes alone. We also observe that $\hat{\rho}_{AR}(t, t - \tau)$ is the density operator for the cavity modes plus an atom at time t , with the atom being removed from the cavity at this time. We can also express this operator as

$$\hat{\rho}_{AR}(t, t - \tau) = \hat{\rho}_A(t - \tau) \hat{\rho}(t). \quad (3.8)$$

Now with the aid of (3.7) and (3.8), we can rewrite (3.6) as

$$\frac{d}{dt} \hat{\rho}_{AR}(t) = r_a (\hat{\rho}_A(0) - \hat{\rho}_A(t - \tau)) \hat{\rho}(t) + r_a \int_{t-\tau}^t \frac{\partial}{\partial t} \hat{\rho}_{AR}(t, t') dt'. \quad (3.9)$$

In view of (2.10), Eq.(3.9) takes the form

$$\frac{d}{dt} \hat{\rho}_{AR}(t) = r_a (\hat{\rho}_A(0) - \hat{\rho}_A(t - \tau)) \hat{\rho}(t) - i r_a \int_{t-\tau}^t [\hat{H}, \hat{\rho}(t, t')] dt', \quad (3.10)$$

and applying (3.5), Eq.(3.10) can be put in the form

$$\frac{d}{dt} \hat{\rho}_{AR}(t) = r_a (\hat{\rho}_A(0) - \hat{\rho}_A(t - \tau)) \hat{\rho}(t) - i [\hat{H}, \hat{\rho}_{AR}(t)]. \quad (3.11)$$

Moreover, tracing over the atomic variables and taking into consideration the damping of the cavity modes by vacuum reservoirs, we have

$$\frac{d}{dt} \hat{\rho} = r_a \text{Tr}_A (\hat{\rho}_A(0) - \hat{\rho}_A(t - \tau)) \hat{\rho}(t) - i \text{Tr}_A [\hat{H}, \hat{\rho}_{AR}(t)]$$

$$+\frac{1}{2}\kappa(2\hat{a}\hat{\rho}\hat{a}^\dagger - \hat{\rho}\hat{a}^\dagger\hat{a} - \hat{a}^\dagger\hat{a}\hat{\rho} + 2\hat{b}\hat{\rho}\hat{b}^\dagger - \hat{\rho}\hat{b}^\dagger\hat{b} - \hat{b}^\dagger\hat{b}\hat{\rho}). \quad (3.12)$$

where κ , assumed the same for both modes, is the cavity damping constant. Taking into account (2.14) we see that

$$\frac{d}{dt}\hat{\rho} = -iTr_A[\hat{H}, \hat{\rho}_{AR}(t)] + \frac{1}{2}\kappa(2\hat{a}\hat{\rho}\hat{a}^\dagger - \hat{\rho}\hat{a}^\dagger\hat{a} - \hat{a}^\dagger\hat{a}\hat{\rho} + 2\hat{b}\hat{\rho}\hat{b}^\dagger - \hat{\rho}\hat{b}^\dagger\hat{b} - \hat{b}^\dagger\hat{b}\hat{\rho}). \quad (3.13)$$

Making use of (3.1) and applying the cyclic property of the trace operation, Eq.(3.13) can be put in the form

$$\begin{aligned} \frac{d}{dt}\hat{\rho} = & g(\hat{a}^\dagger\hat{\rho}_{ab} - \hat{\rho}_{ab}\hat{a}^\dagger + \hat{b}^\dagger\hat{\rho}_{bc} - \hat{\rho}_{bc}\hat{b}^\dagger + \hat{\rho}_{ba}\hat{a} - \hat{a}\hat{\rho}_{ba} + \hat{\rho}_{cb}\hat{b} - \hat{b}\hat{\rho}_{cb}) \\ & + \frac{1}{2}\kappa(2\hat{a}\hat{\rho}\hat{a}^\dagger - \hat{\rho}\hat{a}^\dagger\hat{a} - \hat{a}^\dagger\hat{a}\hat{\rho} + 2\hat{b}\hat{\rho}\hat{b}^\dagger - \hat{\rho}\hat{b}^\dagger\hat{b} - \hat{b}^\dagger\hat{b}\hat{\rho}), \end{aligned} \quad (3.14)$$

where the matrix element $\hat{\rho}_{\alpha\beta}$ is defined by

$$\hat{\rho}_{\alpha\beta} = \langle\alpha|\hat{\rho}_{AR}|\beta\rangle, \quad (3.15)$$

with $\alpha, \beta = a, b, c$.

On the other hand, employing (3.11) we can write

$$\begin{aligned} \frac{d}{dt}\hat{\rho}_{\alpha\beta} = & r_a(\langle\alpha|\hat{\rho}_A(0)|\beta\rangle - \langle\alpha|\hat{\rho}_A(t-\tau)|\beta\rangle)\hat{\rho}(t) \\ & -i(\langle\alpha|\hat{H}\hat{\rho}_{AR}|\beta\rangle - \langle\alpha|\hat{\rho}_{AR}\hat{H}|\beta\rangle) - \gamma\hat{\rho}_{\alpha\beta}, \end{aligned} \quad (3.16)$$

in which the last term is included to account for the decay of atoms due to spontaneous emission. And γ , taken to be the same for all the three levels, is the atomic decay rate. Here as in chapter 2 we also assume that the atoms are removed from the cavity after they have decayed to a level other than the intermediate or lower level. Thus we have

$$\langle\alpha|\hat{\rho}_A(t-\tau)|\beta\rangle = 0, \quad (3.17)$$

so that Eq.(3.16) reduces to

$$\frac{d}{dt}\hat{\rho}_{\alpha\beta} = r_a\langle\alpha|\hat{\rho}_A(0)|\beta\rangle\hat{\rho}(t) - i(\langle\alpha|\hat{H}\hat{\rho}_{AR}|\beta\rangle - \langle\alpha|\hat{\rho}_{AR}\hat{H}|\beta\rangle) - \gamma\hat{\rho}_{\alpha\beta}. \quad (3.18)$$

Employing this equation and taking into account (3.1) and (3.3), one obtains

$$\frac{d}{dt}\hat{\rho}_{ab} = g(\hat{\rho}_{aa}\hat{a} - \hat{a}\hat{\rho}_{bb} - \hat{\rho}_{ac}\hat{b}^\dagger) - \gamma\hat{\rho}_{ab}, \quad (3.19)$$

$$\frac{d}{dt}\hat{\rho}_{bc} = g(\hat{a}^\dagger\hat{\rho}_{ac} + \hat{\rho}_{bb}\hat{b} - \hat{b}\hat{\rho}_{cc}) - \gamma\hat{\rho}_{bc}, \quad (3.20)$$

$$\frac{d}{dt}\hat{\rho}_{aa} = r_a\rho_{aa}^{(0)}\hat{\rho} - g(\hat{\rho}_{ab}\hat{a}^\dagger + \hat{a}\hat{\rho}_{ba}) - \gamma\hat{\rho}_{aa}, \quad (3.21)$$

$$\frac{d}{dt}\hat{\rho}_{bb} = g(\hat{\rho}_{ba}\hat{a} + \hat{a}^\dagger\hat{\rho}_{ab} - \hat{\rho}_{bc}\hat{b}^\dagger - \hat{b}\hat{\rho}_{cb}) - \gamma\hat{\rho}_{bb}, \quad (3.22)$$

$$\frac{d}{dt}\hat{\rho}_{ac} = r_a\rho_{ac}^{(0)}\hat{\rho} + g(\hat{\rho}_{ab}\hat{b} - \hat{a}\hat{\rho}_{bc}) - \gamma\hat{\rho}_{ac}, \quad (3.23)$$

$$\frac{d}{dt}\hat{\rho}_{cc} = r_a\rho_{cc}^{(0)}\hat{\rho} + g(\hat{\rho}_{cb}\hat{b} + \hat{b}^\dagger\hat{\rho}_{bc}) - \gamma\hat{\rho}_{cc}. \quad (3.24)$$

We confine our discussion to linear analysis by dropping the g-terms in (3.21), (3.22), (3.23), and (3.24). It then follows that

$$\frac{d}{dt}\hat{\rho}_{aa} = r_a\rho_{aa}^{(0)}\hat{\rho} - \gamma\hat{\rho}_{aa}, \quad (3.25)$$

$$\frac{d}{dt}\hat{\rho}_{bb} = -\gamma\hat{\rho}_{bb}, \quad (3.26)$$

$$\frac{d}{dt}\hat{\rho}_{ac} = r_a\rho_{ac}^{(0)}\hat{\rho} - \gamma\hat{\rho}_{ac}, \quad (3.27)$$

$$\frac{d}{dt}\hat{\rho}_{cc} = r_a\rho_{cc}^{(0)}\hat{\rho} - \gamma\hat{\rho}_{cc}. \quad (3.28)$$

Here again we assume that $\kappa \ll g, \gamma$ (the good-cavity limit). In the good-cavity limit, the cavity mode variables change slowly compared with the atomic variables. Since the atomic variables reach steady state in the relatively short period of γ^{-1} , we can take the time derivatives of such variables to be zero, while keeping the zero-order atomic and

cavity mode variables at time t . Employing this adiabatic approximation scheme, we get from Eqs.(3.25), (3.26), (3.27), and (3.28) that

$$\hat{\rho}_{aa} = \frac{r_a \rho_{aa}^{(0)}}{\gamma} \hat{\rho}, \quad (3.29)$$

$$\hat{\rho}_{bb} = 0, \quad (3.30)$$

$$\hat{\rho}_{ac} = \frac{r_a \rho_{ac}^{(0)}}{\gamma} \hat{\rho}, \quad (3.31)$$

$$\hat{\rho}_{cc} = \frac{r_a \rho_{cc}^{(0)}}{\gamma} \hat{\rho}. \quad (3.32)$$

Now combination of (3.19), (3.29), (3.30), and (3.31) as well as (3.20), (3.30), (3.31), and (3.32) yields

$$\frac{d}{dt} \hat{\rho}_{ab} = \frac{gr_a}{\gamma} (\rho_{aa}^{(0)} \hat{\rho} \hat{a} - \rho_{ac}^{(0)} \hat{\rho} \hat{b}^\dagger) - \gamma \hat{\rho}_{ab}, \quad (3.33)$$

$$\frac{d}{dt} \hat{\rho}_{bc} = \frac{gr_a}{\gamma} (\rho_{ac}^{(0)} \hat{a}^\dagger \hat{\rho} - \rho_{cc}^{(0)} \hat{b} \hat{\rho}) - \gamma \hat{\rho}_{bc}. \quad (3.34)$$

Employing again the adiabatic approximation scheme, we easily find

$$\hat{\rho}_{ab} = \frac{gr_a}{\gamma^2} (\rho_{aa}^{(0)} \hat{\rho} \hat{a} - \rho_{ac}^{(0)} \hat{\rho} \hat{b}^\dagger), \quad (3.35)$$

$$\hat{\rho}_{bc} = \frac{gr_a}{\gamma^2} (\rho_{ac}^{(0)} \hat{a}^\dagger \hat{\rho} - \rho_{cc}^{(0)} \hat{b} \hat{\rho}). \quad (3.36)$$

On account of (3.35), (3.36), and (3.14) the equation of evolution of the density operator for the cavity modes takes the form

$$\begin{aligned} \frac{d}{dt} \hat{\rho} = & \frac{1}{2} A \rho_{aa}^{(0)} (2\hat{a}^\dagger \hat{\rho} \hat{a} - \hat{\rho} \hat{a} \hat{a}^\dagger - \hat{a} \hat{a}^\dagger \hat{\rho}) + \frac{1}{2} A \rho_{cc}^{(0)} (2\hat{b} \hat{\rho} \hat{b}^\dagger - \hat{\rho} \hat{b}^\dagger \hat{b} - \hat{b}^\dagger \hat{b} \hat{\rho}) \\ & + \frac{1}{2} A \rho_{ac}^{(0)} (\hat{\rho} \hat{a}^\dagger \hat{b}^\dagger + \hat{a}^\dagger \hat{b}^\dagger \hat{\rho} - 2\hat{a}^\dagger \hat{\rho} \hat{b}^\dagger) + \frac{1}{2} A \rho_{ca}^{(0)} (\hat{\rho} \hat{a} \hat{b} + \hat{a} \hat{b} \hat{\rho} - 2\hat{b} \hat{\rho} \hat{a}) \\ & + \frac{1}{2} \kappa (2\hat{a} \hat{\rho} \hat{a}^\dagger - \hat{\rho} \hat{a}^\dagger \hat{a} - \hat{a}^\dagger \hat{a} \hat{\rho} + 2\hat{b} \hat{\rho} \hat{b}^\dagger - \hat{\rho} \hat{b}^\dagger \hat{b} - \hat{b}^\dagger \hat{b} \hat{\rho}), \end{aligned} \quad (3.37)$$

where

$$A = 2r_a \frac{g^2}{\gamma^2} \quad (3.38)$$

is the linear gain coefficient. It is worth to mention that the quantum properties of the light generated by a nondegenerate three-level laser are determined by the master equation (3.37). It is easy to see that with $\hat{b} = \hat{a}$ and $\kappa_b=0$, this equation goes to the master equation of a coherently prepared degenerate three-level laser.

With the aid of the master equation (3.37) along with (2.42) and (2.43), it is easy to verify that

$$\frac{d}{dt}\langle\hat{a}\rangle = \frac{1}{2}p\langle\hat{a}\rangle - \frac{1}{2}A\rho_{ac}^{(0)}\langle\hat{b}^\dagger\rangle, \quad (3.39a)$$

$$\frac{d}{dt}\langle\hat{b}^\dagger\rangle = \frac{1}{2}A\rho_{ca}^{(0)}\langle\hat{a}\rangle - \frac{1}{2}q\langle\hat{b}^\dagger\rangle, \quad (3.39b)$$

$$\frac{d}{dt}\langle\hat{a}^2\rangle = p\langle\hat{a}^2\rangle - A\rho_{ac}^{(0)}\langle\hat{a}\hat{b}^\dagger\rangle, \quad (3.39c)$$

$$\frac{d}{dt}\langle\hat{b}^2\rangle = -q\langle\hat{b}^2\rangle + A\rho_{ac}^{(0)}\langle\hat{a}^\dagger\hat{b}\rangle, \quad (3.39d)$$

$$\frac{d}{dt}\langle\hat{a}\hat{b}^\dagger\rangle = \frac{1}{2}(p-q)\langle\hat{a}\hat{b}^\dagger\rangle + \frac{1}{2}A\rho_{ca}^{(0)}\langle\hat{a}^2\rangle - \frac{1}{2}A\rho_{ac}^{(0)}\langle\hat{b}^{\dagger 2}\rangle, \quad (3.39e)$$

$$\frac{d}{dt}\langle\hat{a}^\dagger\hat{a}\rangle = p\langle\hat{a}^\dagger\hat{a}\rangle - \frac{1}{2}A\rho_{ca}^{(0)}\langle\hat{a}\hat{b}\rangle - \frac{1}{2}A\rho_{ac}^{(0)}\langle\hat{a}^\dagger\hat{b}^\dagger\rangle + A\rho_{aa}^{(0)}, \quad (3.39f)$$

$$\frac{d}{dt}\langle\hat{b}^\dagger\hat{b}\rangle = -q\langle\hat{b}^\dagger\hat{b}\rangle + \frac{1}{2}A\rho_{ca}^{(0)}\langle\hat{a}\hat{b}\rangle + \frac{1}{2}A\rho_{ac}^{(0)}\langle\hat{a}^\dagger\hat{b}^\dagger\rangle, \quad (3.39g)$$

$$\frac{d}{dt}\langle\hat{a}\hat{b}\rangle = \frac{1}{2}(p-q)\langle\hat{a}\hat{b}\rangle + \frac{1}{2}A\rho_{ac}^{(0)}(\langle\hat{a}^\dagger\hat{a}\rangle - \langle\hat{b}^\dagger\hat{b}\rangle + 1), \quad (3.39h)$$

in which

$$p = A\rho_{aa}^{(0)} - \kappa, \quad (3.40)$$

$$q = A\rho_{cc}^{(0)} + \kappa. \quad (3.41)$$

The steady state solutions of these equations are found to be

$$\langle\hat{a}\rangle_{ss} = 0, \quad (3.42a)$$

$$\langle\hat{b}^\dagger\rangle_{ss} = 0, \quad (3.42b)$$

$$\langle\hat{a}^2\rangle = 0, \quad (3.42c)$$

$$\langle \hat{b}^{\dagger 2} \rangle_{ss} = 0, \quad (3.42d)$$

$$\langle \hat{a} \hat{b}^{\dagger} \rangle_{ss} = 0, \quad (3.42e)$$

$$\langle \hat{a}^{\dagger} \hat{a} \rangle_{ss} = \frac{-A^3 \rho_{aa}^{(0)} |\rho_{ac}^{(0)}|^2 + A^2 |\rho_{ac}^{(0)}|^2 q + A \rho_{aa}^{(0)} (p - q) q}{[A^2 |\rho_{ac}^{(0)}|^2 - pq](p - q)}, \quad (3.42f)$$

$$\langle \hat{b}^{\dagger} \hat{b} \rangle_{ss} = \frac{-A^3 \rho_{aa}^{(0)} |\rho_{ac}^{(0)}|^2 + A^2 |\rho_{ac}^{(0)}|^2 p}{[A^2 |\rho_{ac}^{(0)}|^2 - pq](p - q)}, \quad (3.42g)$$

$$\langle \hat{a} \hat{b} \rangle_{ss} = \frac{(-A \rho_{aa}^{(0)} + p) A q \rho_{ac}^{(0)}}{[A^2 |\rho_{ac}^{(0)}|^2 - pq](p - q)}, \quad (3.42h)$$

where *ss* denotes steady state.

3.2 Quadrature Variance

We now proceed to calculate the quadrature variance. The variance of the quadrature operators

$$\hat{c}_+ = \frac{1}{\sqrt{2}}(\hat{a}_+ + \hat{b}_+), \quad (3.43)$$

and

$$\hat{c}_- = \frac{1}{\sqrt{2}}(\hat{a}_- + \hat{b}_-), \quad (3.44)$$

are defined by

$$\Delta c_{\pm}^2 = \langle \hat{c}_{\pm}^2 \rangle - \langle \hat{c}_{\pm} \rangle^2. \quad (3.45)$$

These operators are Hermitian and satisfying the commutation relation

$$[\hat{c}_+, \hat{c}_-] = 2i. \quad (3.46)$$

In view of (3.42a) and (3.45b) along with (2.51) and (2.52) it is easy to show that

$$\langle \hat{c}_{\pm} \rangle = 0, \quad (3.47)$$

and hence Eq.(3.45) reduces to

$$\Delta c_{\pm}^2 = \langle \hat{c}_{\pm}^2 \rangle. \quad (3.48)$$

Using the definitions (3.43) and (3.44) as well as (2.51) and (2.52), we can rewrite (3.48) as

$$\Delta c_{\pm}^2 = 1 + \langle \hat{a}^\dagger \hat{a} \rangle + \langle \hat{b}^\dagger \hat{b} \rangle + \langle \hat{a}^\dagger \hat{b} \rangle + \langle \hat{a} \hat{b}^\dagger \rangle \pm \frac{1}{2} \left(\langle \hat{a}^2 \rangle + \langle \hat{a}^{\dagger 2} \rangle + \langle \hat{b}^2 \rangle + \langle \hat{b}^{\dagger 2} \rangle + 2\langle \hat{a} \hat{b} \rangle + 2\langle \hat{a}^\dagger \hat{b}^\dagger \rangle \right). \quad (3.49)$$

On account of the results (3.42c), (3.42d), and (3.42e) expression (3.49) becomes

$$\Delta c_{\pm}^2 = 1 + \langle \hat{a}^\dagger \hat{a} \rangle + \langle \hat{b}^\dagger \hat{b} \rangle \pm \left(\langle \hat{a} \hat{b} \rangle + \langle \hat{a}^\dagger \hat{b}^\dagger \rangle \right), \quad (3.50)$$

and substitution of (3.42f), (3.42g), and (3.42h) into (3.50) yields

$$\begin{aligned} \Delta c_{\pm}^2 = & \frac{[A^2 |\rho_{ac}^{(0)}|^2 - pq](p - q) - A^3 \rho_{aa}^{(0)} |\rho_{ac}^{(0)}|^2 + A^2 |\rho_{ac}^{(0)}|^2 q + A \rho_{aa}^{(0)} (p - q) q}{[A^2 |\rho_{ac}^{(0)}|^2 - pq](p - q)} \\ & + \frac{-A^3 \rho_{aa}^{(0)} |\rho_{ac}^{(0)}|^2 + A^2 |\rho_{ac}^{(0)}|^2 p \pm (-A \rho_{aa}^{(0)} + p) A q (\rho_{ac}^{(0)} + \rho_{ca}^{(0)})}{[A^2 |\rho_{ac}^{(0)}|^2 - pq](p - q)}. \end{aligned} \quad (3.51)$$

So that upon setting

$$\rho_{ac}^{(0)} = |\rho_{ac}^{(0)}| e^{i\theta}, \quad (3.52)$$

and taking into account (3.40), and (3.41), the quadrature variance takes the form

$$\begin{aligned} \Delta c_{\pm}^2 = & \frac{-\kappa A^2 |\rho_{ac}^{(0)}|^2 - \kappa A^2 \rho_{cc}^{(0)2} - 3\kappa^2 A \rho_{cc}^{(0)} + \kappa^2 A \rho_{aa}^{(0)} - 2\kappa^3}{2\kappa A^2 |\rho_{ac}^{(0)}|^2 - \kappa A^2 \rho_{cc}^{(0)2} - \kappa A^2 \rho_{aa}^{(0)2} - 3\kappa^2 A \rho_{cc}^{(0)} + 3\kappa^2 A \rho_{aa}^{(0)} - 2\kappa^3} \\ & \pm \frac{-2\kappa A |\rho_{ac}^{(0)}| (A \rho_{cc}^{(0)} + \kappa) \cos \theta}{2\kappa A^2 |\rho_{ac}^{(0)}|^2 - \kappa A^2 \rho_{cc}^{(0)2} - \kappa A^2 \rho_{aa}^{(0)2} - 3\kappa^2 A \rho_{cc}^{(0)} + 3\kappa^2 A \rho_{aa}^{(0)} - 2\kappa^3}. \end{aligned} \quad (3.53)$$

Applying the relations (2.59) to (2.64), the quadrature variance can be put in the form

$$\Delta c_{\pm}^2 = \frac{\left(\frac{\kappa A^2}{2} + 2\kappa^2 A \right) \eta + \left(\frac{\kappa A^2}{2} + \kappa^2 A + 2\kappa^3 \right) \pm \left(\frac{\kappa A^2}{2} (\eta^2 - \eta^4)^{\frac{1}{2}} + \left(\kappa^2 A + \frac{\kappa A^2}{2} \right) (1 - \eta^2)^{\frac{1}{2}} \right)}{(\kappa A^2 \eta^2 + 3\kappa^2 A \eta + 2\kappa^3)}. \quad (3.54)$$

Fig.3.2 clearly shows that the cavity modes are in a two-mode squeezed state for all values of η between zero and one and the degree of squeezing increases as the linear gain coefficient increases.

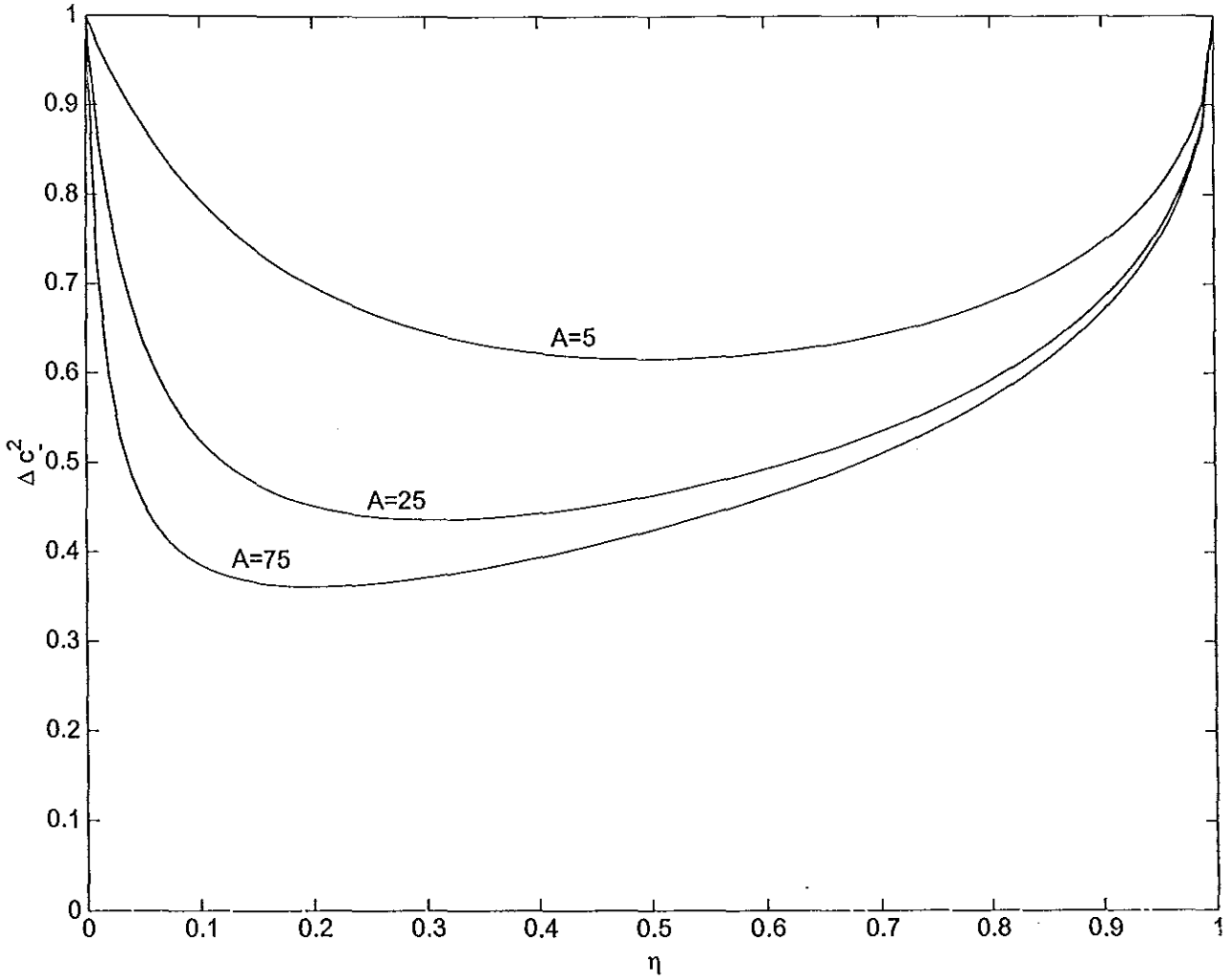

Fig. 3.2 Plots of the quadrature variance Δc_{\pm}^2 versus η for $\kappa=0.8$, and $\theta=0$, and for different values of the linear gain coefficient.

3.3 Squeezing Spectrum

For a two-mode light the squeezing spectrum is expressible as

$$S_{\pm}^{out}(\omega) = 1 + 2\text{Re} \int_0^{\infty} \langle : \hat{c}_{\pm}^{out}(t), \hat{c}_{\pm}^{out}(t + \tau) : \rangle_{ss} e^{i\omega\tau} d\tau \quad (3.55)$$

where

$$\hat{c}_{+}^{out}(t) = \frac{1}{\sqrt{2}}(\hat{a}_{+}^{out}(t) + \hat{b}_{+}^{out}(t)), \quad (3.56)$$

$$\hat{c}_{-}^{out}(t) = \frac{1}{\sqrt{2}}(\hat{a}_{-}^{out}(t) + \hat{b}_{-}^{out}(t)). \quad (3.57)$$

It is not difficult to notice that for a cavity mode coupled to a vacuum reservoir, the output and intracavity variables are related by

$$\hat{c}_{\pm}^{out}(t) = \sqrt{\kappa}\hat{c}_{\pm}(t). \quad (3.58)$$

In view of (3.58), Eq.(3.55) can be expressed in terms of the intracavity variables as

$$S_{\pm}^{out}(\omega) = 1 + 2\kappa Re \int_0^{\infty} \langle : \hat{c}_{\pm}(t), \hat{c}_{\pm}(t + \tau) : \rangle_{ss} e^{i\omega\tau} d\tau, \quad (3.59)$$

in which

$$\langle \hat{c}_{\pm}(t), \hat{c}_{\pm}(t + \tau) \rangle = \langle \hat{c}_{\pm}(t)\hat{c}_{\pm}(t + \tau) \rangle - \langle \hat{c}_{\pm}(t) \rangle \langle \hat{c}_{\pm}(t + \tau) \rangle. \quad (3.60)$$

Therefore, on account of (3.47), and (3.60), the squeezing spectrum (3.59) can be put in the form

$$S_{\pm}^{out}(\omega) = 1 + 2\kappa Re \int_0^{\infty} \langle : \hat{c}_{\pm}(t)\hat{c}_{\pm}(t + \tau) : \rangle_{ss} e^{i\omega\tau} d\tau. \quad (3.61)$$

Moreover from Eqs.(3.39a) and (3.39b), we have

$$\frac{d}{dt} \langle \hat{a}(t) \rangle = \frac{1}{2}p \langle \hat{a}(t) \rangle - \frac{1}{2}A\rho_{ac}^{(0)} \langle \hat{b}^{\dagger}(t) \rangle, \quad (3.62)$$

$$\frac{d}{dt} \langle \hat{b}^{\dagger}(t) \rangle = \frac{1}{2}A\rho_{ca}^{(0)} \langle \hat{a}(t) \rangle - \frac{1}{2}q \langle \hat{b}^{\dagger}(t) \rangle. \quad (3.63)$$

In view of (3.62)

$$\langle \hat{b}^{\dagger}(t) \rangle = \frac{2}{A\rho_{ac}^{(0)}} \left[\frac{1}{2}p \langle \hat{a}(t) \rangle - \frac{d}{dt} \langle \hat{a}(t) \rangle \right], \quad (3.64)$$

substituting this into (3.63) we get

$$\frac{d^2}{dt^2} \langle \hat{a}(t) \rangle - \frac{1}{2}(p - q) \frac{d}{dt} \langle \hat{a}(t) \rangle + \frac{1}{4}(A^2 |\rho_{ac}^{(0)}|^2 - pq) \langle \hat{a}(t) \rangle = 0. \quad (3.65)$$

From (3.63) we also have

$$\langle \hat{a}(t) \rangle = \frac{2}{A\rho_{ca}^{(0)}} \left[\frac{d}{dt} \langle \hat{b}^{\dagger}(t) \rangle + \frac{1}{2}q \langle \hat{b}^{\dagger}(t) \rangle \right], \quad (3.66)$$

so that inserting this into (3.62) leads to

$$\frac{d^2}{dt^2}\langle\hat{b}^\dagger(t)\rangle - \frac{1}{2}(p-q)\frac{d}{dt}\langle\hat{b}^\dagger(t)\rangle + \frac{1}{4}(A^2|\rho_{ac}^{(0)}|^2 - pq)\langle\hat{b}^\dagger(t)\rangle = 0. \quad (3.67)$$

The solutions of (3.65) and (3.67) are expressible as

$$\langle\hat{a}(t+\tau)\rangle = (a_1\langle\hat{a}(t)\rangle - a_2\langle\hat{b}^\dagger(t)\rangle)e^{\lambda_1\tau} - (a_3\langle\hat{a}(t)\rangle - a_2\langle\hat{b}^\dagger(t)\rangle)e^{\lambda_2\tau} \quad (3.68)$$

and

$$\langle\hat{b}^\dagger(t+\tau)\rangle = (a_4^*\langle\hat{a}(t)\rangle - a_3^*\langle\hat{b}^\dagger(t)\rangle)e^{\lambda_1\tau} - (a_4^*\langle\hat{a}(t)\rangle - a_1^*\langle\hat{b}^\dagger(t)\rangle)e^{\lambda_2\tau}, \quad (3.69)$$

where

$$\lambda_1 = \frac{1}{4}(p-q) + \frac{1}{4}\sqrt{(p-q)^2 - 4(A^2|\rho_{ac}^{(0)}|^2 - pq)}, \quad (3.70a)$$

$$\lambda_2 = \frac{1}{4}(p-q) - \frac{1}{4}\sqrt{(p-q)^2 - 4(A^2|\rho_{ac}^{(0)}|^2 - pq)}, \quad (3.70b)$$

$$a_1 = \frac{\frac{1}{2}p - \lambda_2}{\lambda_1 - \lambda_2}, \quad (3.70c)$$

$$a_2 = \frac{A\rho_{ac}^{(0)}}{2(\lambda_1 - \lambda_2)}, \quad (3.70d)$$

$$a_3 = \frac{\frac{1}{2}p - \lambda_1}{\lambda_1 - \lambda_2}, \quad (3.70e)$$

$$a_4 = \frac{2(\frac{1}{2}p - \lambda_1)(\frac{1}{2}p - \lambda_2)}{A\rho_{ca}^{(0)}(\lambda_1 - \lambda_2)}. \quad (3.70f)$$

Furthermore, using (3.43) and (3.44), the expectation values of the intracavity quadrature operators can be written as

$$\langle\hat{c}_\pm(t+\tau)\rangle = \frac{1}{\sqrt{2}}(\langle\hat{a}_\pm(t+\tau)\rangle + \langle\hat{b}_\pm(t+\tau)\rangle). \quad (3.71)$$

Applying (2.51) and (2.52) and a similar definition for \hat{b}_\pm , one gets

$$\langle\hat{c}_+(t+\tau)\rangle = \frac{1}{\sqrt{2}}(\langle\hat{a}^\dagger(t+\tau)\rangle + \langle\hat{a}(t+\tau)\rangle + \langle\hat{b}^\dagger(t+\tau)\rangle + \langle\hat{b}(t+\tau)\rangle) \quad (3.72)$$

and

$$\langle\hat{c}_-(t+\tau)\rangle = \frac{i}{\sqrt{2}}(\langle\hat{a}^\dagger(t+\tau)\rangle - \langle\hat{a}(t+\tau)\rangle + \langle\hat{b}^\dagger(t+\tau)\rangle - \langle\hat{b}(t+\tau)\rangle). \quad (3.73)$$

Now substituting (3.68) and(3.69) along with their complex conjugates into (3.72) and (3.73) we find

$$\begin{aligned} \langle \hat{c}_+(t+\tau) \rangle &= \frac{1}{\sqrt{2}} [((a_1^* + a_4) \langle \hat{a}^\dagger(t) \rangle + (a_4^* + a_1) \langle \hat{a}(t) \rangle - (a_3^* + a_2) \langle \hat{b}^\dagger(t) \rangle - (a_2^* + a_3) \langle \hat{b}(t) \rangle) e^{\lambda_1 \tau} \\ &+ ((a_1^* + a_2) \langle \hat{b}^\dagger(t) \rangle + (a_2^* + a_1) \langle \hat{b}(t) \rangle - (a_3^* + a_4) \langle \hat{a}^\dagger(t) \rangle - (a_4^* + a_3) \langle \hat{a}(t) \rangle) e^{\lambda_2 \tau}] \end{aligned} \quad (3.74)$$

and

$$\begin{aligned} \langle \hat{c}_-(t+\tau) \rangle &= \frac{i}{\sqrt{2}} [((a_1^* - a_4) \langle \hat{a}^\dagger(t) \rangle + (a_4^* - a_1) \langle \hat{a}(t) \rangle - (a_3^* - a_2) \langle \hat{b}^\dagger(t) \rangle - (a_2^* - a_3) \langle \hat{b}(t) \rangle) e^{\lambda_1 \tau} \\ &+ ((a_1^* - a_2) \langle \hat{b}^\dagger(t) \rangle + (a_2^* - a_1) \langle \hat{b}(t) \rangle - (a_3^* - a_4) \langle \hat{a}^\dagger(t) \rangle - (a_4^* - a_3) \langle \hat{a}(t) \rangle) e^{\lambda_2 \tau}]. \end{aligned} \quad (3.75)$$

Employing the quantum regration theorem and taking into account (3.42c), (3.42d), and (3.42e) one arrives at

$$\langle : \hat{c}_\pm(t) \hat{c}_\pm(t+\tau) : \rangle_{ss} = \frac{1}{2} (A_\pm e^{\lambda_1 \tau} - B_\pm e^{\lambda_2 \tau}), \quad (3.76)$$

where

$$\begin{aligned} A_\pm &= (a_1 + a_1^* \pm (a_4 + a_4^*)) \langle \hat{a}^\dagger(t) \hat{a}(t) \rangle_{ss} - (a_3 + a_3^* \pm (a_2 + a_2^*)) \langle \hat{b}^\dagger(t) \hat{b}(t) \rangle_{ss} \\ &+ (a_4 - a_2 \pm (a_1^* - a_3^*)) \langle \hat{a}^\dagger(t) \hat{b}^\dagger(t) \rangle_{ss} + (a_4^* - a_2^* \pm (a_1 - a_3)) \langle \hat{a}(t) \hat{b}(t) \rangle_{ss} \end{aligned} \quad (3.77)$$

and

$$\begin{aligned} B_\pm &= (a_3 + a_3^* \pm (a_4 + a_4^*)) \langle \hat{a}^\dagger(t) \hat{a}(t) \rangle_{ss} - (a_1 + a_1^* \pm (a_2 + a_2^*)) \langle \hat{b}^\dagger(t) \hat{b}(t) \rangle_{ss} \\ &+ (a_4 - a_2 \pm (a_3^* - a_1^*)) \langle \hat{a}^\dagger(t) \hat{b}^\dagger(t) \rangle_{ss} + (a_4^* - a_2^* \pm (a_3 - a_1)) \langle \hat{a}(t) \hat{b}(t) \rangle_{ss}, \end{aligned} \quad (3.78)$$

so that using the expressions (3.70a), (3.70b), (3.70c), (3.70d) and their complex conjugates, we can rewrite A_\pm and B_\pm as

$$A_\pm = \frac{(p - 2\lambda_2 \pm A|\rho_{ac}^{(0)}|)}{\lambda_1 - \lambda_2} \langle \hat{a}^\dagger(t) \hat{a}(t) \rangle_{ss} - \frac{(p - 2\lambda_1 \pm A|\rho_{ac}^{(0)}|)}{\lambda_1 - \lambda_2} \langle \hat{b}^\dagger(t) \hat{b}(t) \rangle_{ss}$$

$$\pm(\langle \hat{a}^\dagger(t)\hat{b}^\dagger(t) \rangle_{ss} + \langle \hat{a}(t)\hat{b}(t) \rangle_{ss}) \quad (3.79)$$

and

$$B_\pm = \frac{(p - 2\lambda_1 \pm A|\rho_{ac}^{(0)}|)}{\lambda_1 - \lambda_2} \langle \hat{a}^\dagger(t)\hat{a}(t) \rangle_{ss} - \frac{(p - 2\lambda_2 \pm A|\rho_{ac}^{(0)}|)}{\lambda_1 - \lambda_2} \langle \hat{b}^\dagger(t)\hat{b}(t) \rangle_{ss} \\ \pm(\langle \hat{a}^\dagger(t)\hat{b}^\dagger(t) \rangle_{ss} + \langle \hat{a}(t)\hat{b}(t) \rangle_{ss}). \quad (3.80)$$

Upon introducing (3.76) into (3.61), the squeezing spectrum takes the form

$$S_\pm^{out}(\omega) = 1 + \kappa \left[A_\pm Re \int_0^\infty e^{(\lambda_1 + i\omega)\tau} d\tau - B_\pm Re \int_0^\infty e^{(\lambda_2 + i\omega)\tau} d\tau \right]. \quad (3.81)$$

Carrying out the integration leads to

$$S_\pm^{out}(\omega) = 1 - \kappa \left[A_\pm \frac{\lambda_1}{\lambda_1^2 + \omega^2} - B_\pm \frac{\lambda_2}{\lambda_2^2 + \omega^2} \right]. \quad (3.82)$$

For $\omega=0$ the squeezing spectrum becomes

$$S_\pm^{out}(0) = 1 - \kappa \left[\frac{\lambda_2 A_\pm - \lambda_1 B_\pm}{\lambda_1 \lambda_2} \right]. \quad (3.82)$$

Now with the aid of (3.79) and (3.80), one readily gets

$$S_\pm^{out}(0) = 1 - \kappa \frac{[\lambda_2(p - 2\lambda_2 \pm A|\rho_{ac}^{(0)}|) - \lambda_1(p - 2\lambda_1 \pm A|\rho_{ac}^{(0)}|)] \langle \hat{a}^\dagger \hat{a} \rangle_{ss} \\ - \kappa \frac{[\lambda_1(p - 2\lambda_2 \pm A|\rho_{ac}^{(0)}|) - \lambda_2(p - 2\lambda_1 \pm A|\rho_{ac}^{(0)}|)] \langle \hat{b}^\dagger \hat{b} \rangle_{ss} \\ \pm \kappa \frac{(\lambda_1 + \lambda_2)}{\lambda_1 \lambda_2} (\langle \hat{a}^\dagger \hat{b}^\dagger \rangle_{ss} + \langle \hat{a} \hat{b} \rangle_{ss})}{\lambda_1 \lambda_2 (\lambda_1 - \lambda_2)}. \quad (3.84)$$

Next using the steady-state solutions (3.42f),(3.42g), and (3.45h), we have

$$S_-^{out}(0) = \frac{-\kappa A^3 \eta^3 - 2\kappa^2 A^2 \eta^2 + (\kappa^3 A + 2\kappa A^3 + 2\kappa^2 A^2) \eta + (4\kappa^2 A^2 + 4\kappa^3 A + 2\kappa^4)}{\kappa A^3 \eta^3 + 4\kappa^2 A^2 \eta^2 + 5\kappa^3 A \eta + 2\kappa^4} \\ + \frac{-(2\kappa A^3 + 2\kappa^2 A^2)(\eta^2 - \eta^4)^{\frac{1}{2}} - (4\kappa^2 A^2 + 4\kappa^3 A)(1 - \eta^2)^{\frac{1}{2}}}{\kappa A^3 \eta^3 + 4\kappa^2 A^2 \eta^2 + 5\kappa^3 A \eta + 2\kappa^4}. \quad (3.85)$$

Fig. 3.3 shows that for $\omega=0$ there appears to be perfect squeezing for sufficiently large values of A and for values of η very close to zero.

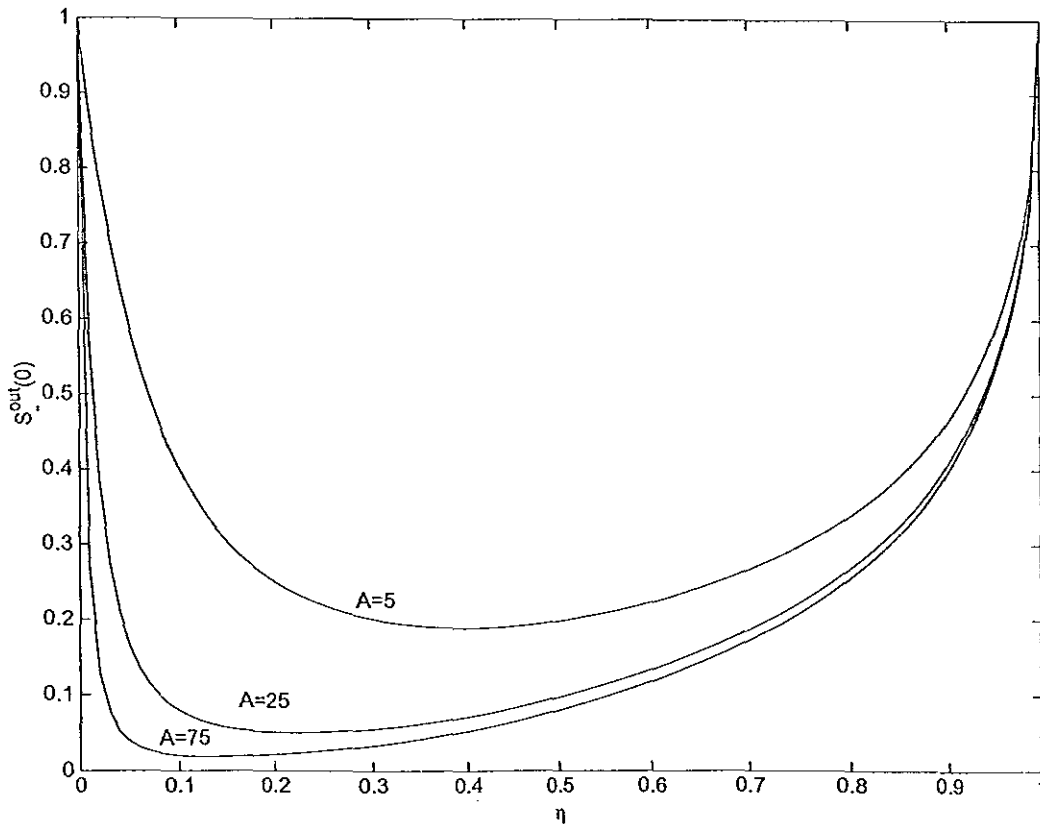

Fig. 3.3 Plots of the squeezing spectrum $S_-^{out}(0)$ versus η for $\kappa=0.8, \theta=0$, and for different values of the linear gain coefficient.

3.4 Photon Statistics

We wish here to calculate the variance of the photon number for both cavity modes and the photon number distribution at steady state for a two-mode light.

A. The variances of the photon number

The variance of the photon number, for one of the cavity modes is expressible as

$$\Delta n_1^2 = \langle \hat{n}_1^2 \rangle - \langle \hat{n}_1 \rangle^2, \quad (3.86)$$

where

$$\hat{n}_1 = \hat{a}^\dagger \hat{a}. \quad (3.87)$$

Applying the commutation relation (2.81), we can rewrite (3.86) as

$$\Delta n_1^2 = \bar{n}_1 + \langle \hat{a}^{\dagger 2} \hat{a}^2 \rangle_{ss} - \bar{n}_1^2. \quad (3.88)$$

We see from (3.42f) the mean photon number, for one of the cavity modes, at steady state is given by

$$\bar{n}_1 = \frac{-A^3 \rho_{aa}^{(0)} |\rho_{ac}^{(0)}|^2 + A^2 |\rho_{ac}^{(0)}|^2 q + A \rho_{aa}^{(0)} (p - q) q}{[A^2 |\rho_{ac}^{(0)}|^2 - pq](p - q)}, \quad (3.89)$$

in terms of η Eq.(3.89) can be put in the form

$$\bar{n}_1 = \frac{-\frac{3\kappa A^2}{4} \eta^2 - (\kappa^2 A - \frac{\kappa A^2}{2}) \eta + \frac{\kappa A^2}{4} + \kappa^2 A}{\kappa A^2 \eta^2 + 3\kappa^2 A \eta + 2\kappa^3}. \quad (3.90)$$

On the other hand, in view of (3.42a) the cavity mode operator \hat{a} at steady state is a Gaussian random variable, so that one can rewrite the variance as

$$\Delta n_1^2 = \bar{n}_1 + \bar{n}_1^2 + \langle \hat{a}^{\dagger 2} \rangle_{ss} \langle \hat{a}^2 \rangle_{ss}, \quad (3.91)$$

on account of (3.42c) the photon number variance reduces to

$$\Delta n_1^2 = \bar{n}_1 + \bar{n}_1^2. \quad (3.92)$$

In fig. 3.4 we see that both the mean photon number and the uncertainty in the photon number for mode a decreases with η .

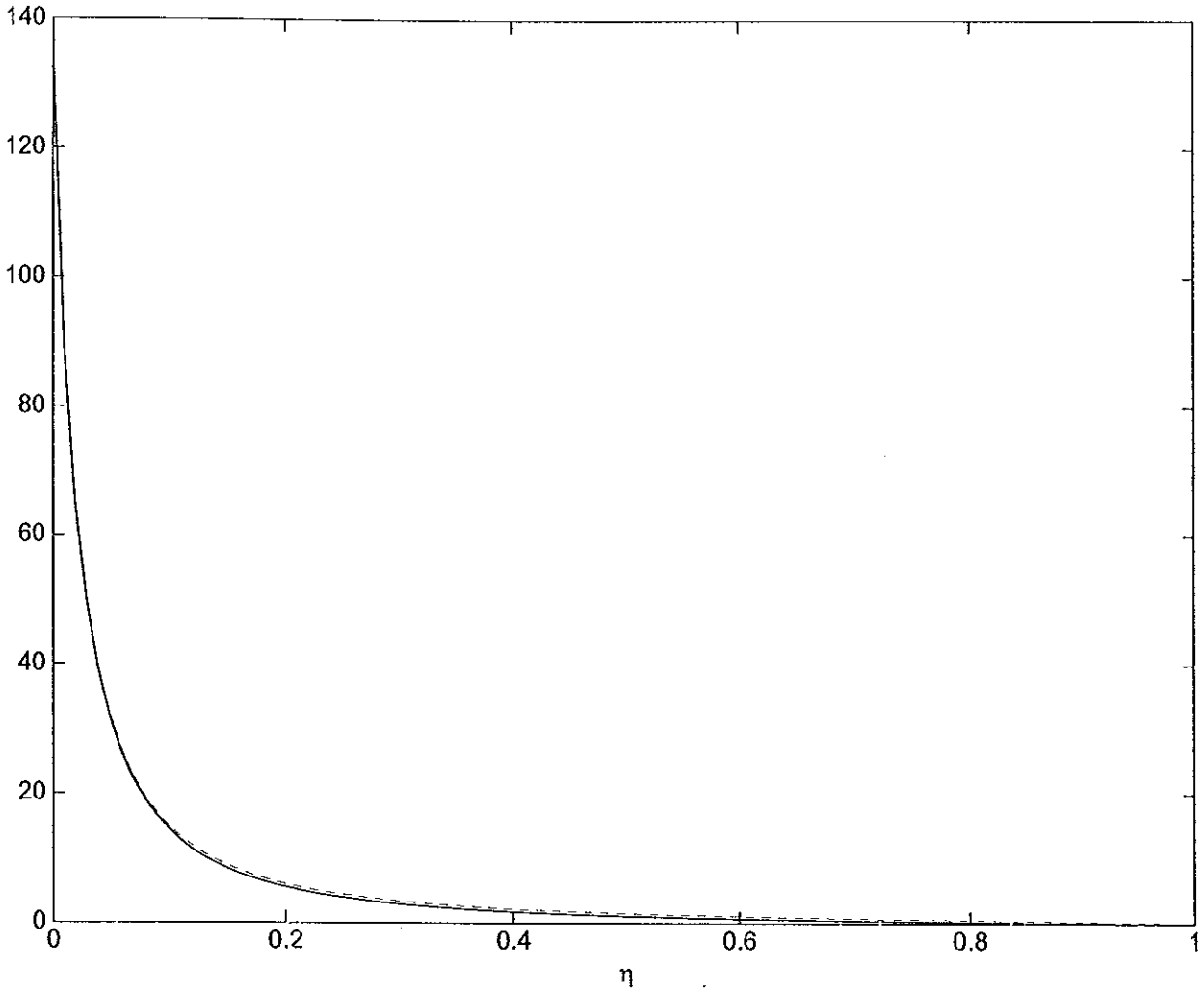

Fig. 3.4 Plots of the mean photon number \bar{n}_1 (solid curve) and the uncertainty in the photon number Δn_1 (dotted curve) versus η for $A=25$ and for $\kappa=0.8$.

Furthermore, the variance of the photon number, for the other mode of the cavity modes can be written as

$$\Delta n_2^2 = \langle \hat{n}_2^2 \rangle - \langle \hat{n}_2 \rangle^2, \quad (3.93)$$

where

$$\hat{n}_2 = \hat{b}^\dagger \hat{b}. \quad (3.94)$$

Using the commutation relation

$$[\hat{b}, \hat{b}^\dagger] = 1, \quad (3.95)$$

one can rewrite Eq.(3.93) as

$$\Delta n_2^2 = \bar{n}_2 + \langle \hat{b}^{\dagger 2} \hat{b}^2 \rangle_{ss} - \bar{n}_2^2. \quad (3.96)$$

In view of (3.42g) the mean photon number $\hat{b}^{\dagger} \hat{b}$, at steady state is given by

$$\bar{n}_2 = \frac{-A^3 \rho_{aa}^{(0)} |\rho_{ac}^{(0)}|^2 + A^2 |\rho_{ac}^{(0)}|^2 p}{[A^2 |\rho_{ac}^{(0)}|^2 - pq](p - q)}, \quad (3.97)$$

in terms of η this can be rewritten as

$$\bar{n}_2 = \frac{-\frac{\kappa A^2}{4} \eta^2 + \frac{\kappa A^2}{4}}{\kappa A^2 \eta^2 + 3\kappa^2 A \eta + 2\kappa^3}. \quad (3.98)$$

One can notice from (3.42b) that, the cavity mode operator \hat{b} at steady state is a Gaussian random variable, so that we can rewrite the variance of the photon number (3.96) as

$$\Delta n_2^2 = \bar{n}_2 + \bar{n}_2^2 + \langle \hat{b}^{\dagger 2} \rangle_{ss} \langle \hat{b}^2 \rangle_{ss}, \quad (3.99)$$

applying (3.42d) the photon number variance reduces to

$$\Delta n_2^2 = \bar{n}_2 + \bar{n}_2^2. \quad (3.100)$$

Fig. 3.5 clearly shows that both the photon number and the uncertainty in the photon number for mode b decreases with η .

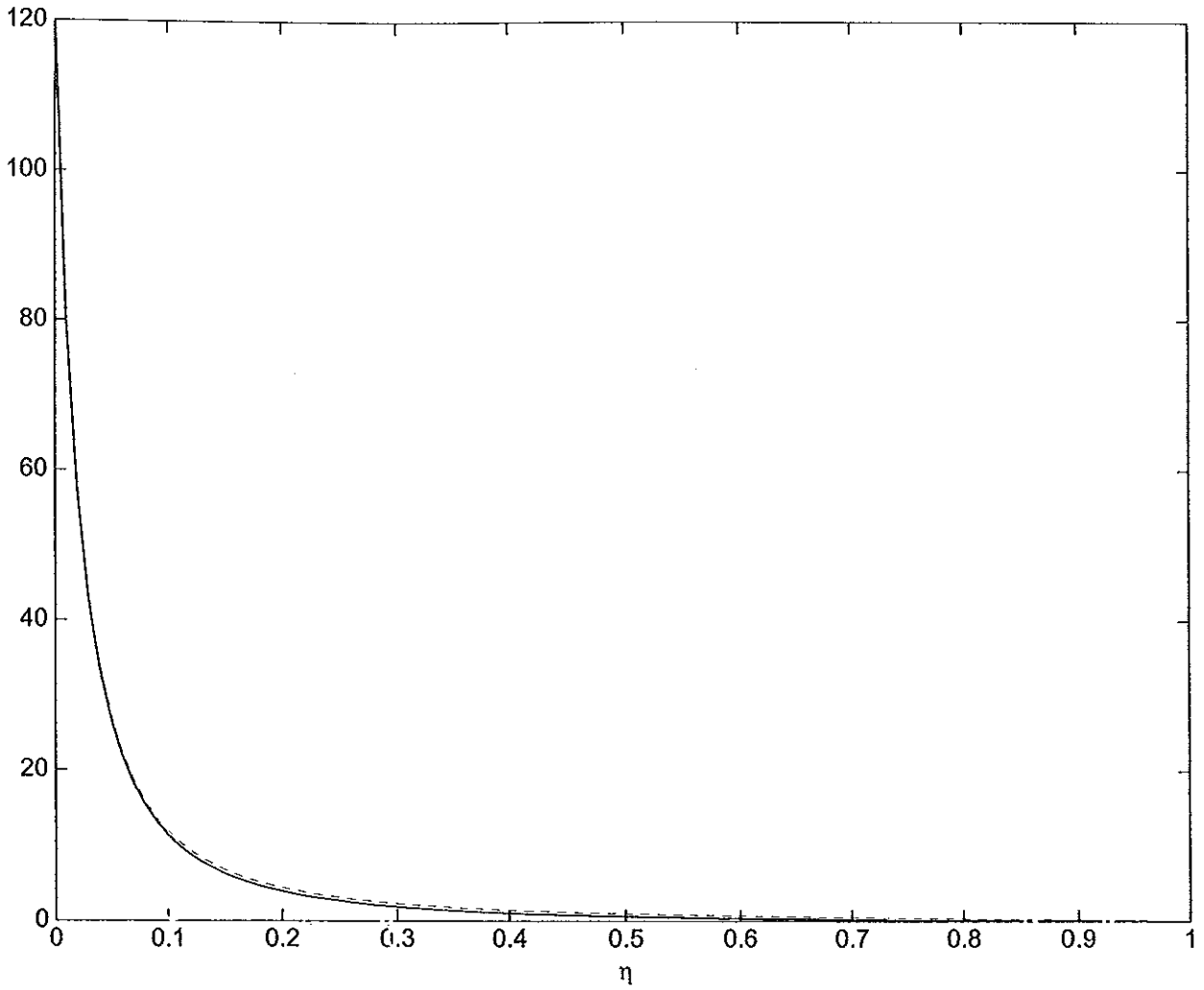

Fig. 3.5 shows the Plots of the mean photon number, \bar{n}_2 , (solid curve) and the uncertainty in the photon number, Δn_2 , (dotted curve) versus η for $A=25$ and $\kappa=0.8$.

B. The Photon Number Distribution

Finally, we proceed to calculate the photon number distribution employing the Q function.

The Q function for a two-mode light is expressible as

$$Q(\alpha, \beta) = \frac{1}{\pi^4} \int d^2 z d^2 \eta \Phi(z, \eta) \exp[z^* \alpha + \eta^* \beta - z \alpha^* - \eta \beta^*], \quad (3.101)$$

here the antinormally ordered characteristic function, for a two-mode light, is defined in the Heisenberg picture as [19]

$$\Phi(z, \eta) = \text{Tr} \left(\hat{\rho}(0) e^{-z^* a(t)} e^{z a^\dagger(t)} e^{-\eta^* b(t)} e^{\eta b^\dagger(t)} \right), \quad (3.102)$$

where $\hat{\rho}(0)$ is the initial density operator for the cavity modes plus reservoir modes.

The characteristic function can be rewritten on account of the Baker-Hausdorff identity (2.80) as

$$\begin{aligned}\Phi(z, \eta) &= e^{-\frac{1}{2}(z^*z + \eta^*\eta)} \text{Tr} \left(\hat{\rho}(0) \exp[z\hat{a}^\dagger(t) - z^*\hat{a}(t) + \eta\hat{b}^\dagger(t) - \eta^*\hat{b}(t)] \right) \\ &= e^{-\frac{1}{2}(z^*z + \eta^*\eta)} \langle \exp[z\hat{a}^\dagger(t) - z^*\hat{a}(t) + \eta\hat{b}^\dagger(t) - \eta^*\hat{b}(t)] \rangle.\end{aligned}\quad (3.103)$$

Since \hat{a} and \hat{b} at steady state are Gaussian random variables, this expression can be put in the form

$$\Phi(z, \eta) = e^{-\frac{1}{2}(z^*z + \eta^*\eta)} \exp \left(\frac{1}{2} \langle [z\hat{a}^\dagger - z^*\hat{a} + \eta\hat{b}^\dagger - \eta^*\hat{b}]^2 \rangle_{ss} \right).\quad (3.104)$$

Squaring the expression in the bracket and employing the commutation relations (2.81) and (3.95), it then follows that

$$\Phi(z, \eta) = \exp[-az^*z - b\eta^*\eta + cz\eta + c^*z^*\eta^*],\quad (3.105)$$

where

$$a = 1 + \langle \hat{a}^\dagger \hat{a} \rangle_{ss},\quad (3.106)$$

$$b = 1 + \langle \hat{b}^\dagger \hat{b} \rangle_{ss},\quad (3.107)$$

$$c = \langle \hat{a}^\dagger \hat{b}^\dagger \rangle_{ss}.\quad (3.108)$$

The above coefficients can be put in terms of η as

$$a = 1 + \frac{-\frac{3A^2\kappa}{4}\eta^2 - (A\kappa^2 - \frac{A^2\kappa}{2})\eta + \frac{A^2\kappa}{4} + A\kappa^2}{\kappa A^2\eta^2 + 3\kappa^2 A\eta + 2\kappa^3},\quad (3.109)$$

$$b = 1 + \frac{-\frac{\kappa A^2}{4}\eta^2 + \frac{\kappa A^2}{4}}{\kappa A^2\eta^2 + 3\kappa^2 A\eta + 2\kappa^3},\quad (3.110)$$

$$c = \frac{\left(\frac{\kappa A^2}{4}\eta + \frac{\kappa A^2}{4} + \frac{\kappa^2 A}{2} \right) (1 - \eta^2)^{1/2}}{\kappa A^2\eta^2 + 3\kappa^2 A\eta + 2\kappa^3} e^{-i\theta}.\quad (3.111)$$

Performing the differentiation we find

$$P(m, n) = \frac{ur - vv^*}{m!n!} \sum_{ijkl} \frac{(1-u)^i (1-r)^j v^k v^{*l}}{i!j!k!l!} \frac{(i+l)!(i+k)!}{(i+l-n)!(i+k-n)!} \frac{(j+l)!(j+k)!}{(j+l-m)!(j+k-m)!} [(\alpha^*)^{i+l-n} \alpha^{i+k-n} (\beta^*)^{j+l-m} \beta^{j+k-m}]_{\alpha^*=\alpha=\beta^*=\beta=0}, \quad (3.120)$$

using the conditions $\alpha^* = \alpha = \beta^* = \beta = 0$, one gets

$$P(m, n) = \frac{ur - vv^*}{m!n!} \sum_{ijkl} \frac{(1-u)^i (1-r)^j v^k v^{*l}}{i!j!k!l!} \frac{(i+l)!(i+k)!}{(i+l-n)!(i+k-n)!} \frac{(j+l)!(j+k)!}{(j+l-m)!(j+k-m)!} \delta_{i+l,n} \delta_{i+k,n} \delta_{j+l,m} \delta_{j+k,m}. \quad (3.121)$$

On account of the property of the Kronecker delta, we note that

$$l = n - i, \quad (3.122)$$

$$k = n - i, \quad (3.123)$$

$$l = m - j, \quad (3.124)$$

$$k = m - j, \quad (3.125)$$

which implies

$$l = k, \quad (3.126)$$

$$i = n - k, \quad (3.127)$$

$$j = m - k. \quad (3.128)$$

In view of these relations, the photon number distribution turns out to be

$$P(m, n) = (ur - vv^*) m!n! \sum_{k=0}^{\min(m,n)} \frac{(1-u)^{n-k} (1-r)^{m-k} v^k v^{*k}}{(n-k)!(m-k)!k!^2}, \quad (3.129)$$

where $\min(m,n)$ is the minimum of m and n . Therefore, for $m = n$ the photon number distribution takes the form

$$P(n, n) = (ur - vv^*) \sum_{k=0}^n \frac{n!^2 [(1-u)(1-r)]^{n-k} (v^*v)^k}{[(n-k)!]^2 k!^2}. \quad (3.130)$$

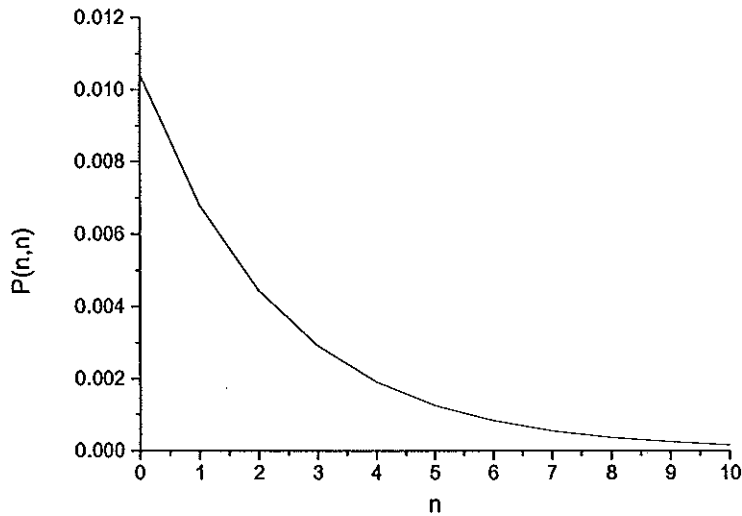

Fig. 3.6 Photon number distribution $p(n,n)$ versus number of photons n for $A=25$, $\kappa=0.8$, $\theta=0$, and $\eta=0.3$.

The probability to observe zero signal and zero idler photons is high. As it is clearly shown in Fig. 3.6 the probability to observe n signal and n idler photons decreases with n .

4. CONCLUSION

We have derived the master equation for the cavity radiation for the coherently prepared degenerate and nondegenerate three-level lasers in the linear and adiabatic (good-cavity limit) approximations. With the aid of this equation, we have obtained the equations of evolution of the first and second-order moments for the cavity mode operators. Employing the steady state solutions of the resulting equations, we have calculated the quadrature variance for the cavity radiation, and using the time dependent solutions the squeezing spectrum of the output radiation. We have seen that for the two systems, the cavity radiation as well as the output radiation is in a squeezed state for values of η between zero and one. We have found that almost perfect squeezing can be achieved for sufficiently large values of the linear gain coefficient.

Furthermore, applying the same solutions we have determined the antinormally ordered characteristic function [19] with the aid of which the Q function has been obtained. Finally, the Q function is used to calculate the photon number distribution [13]. We have found that the distribution function for a coherently prepared degenerate three-level laser has the same form as the distribution function for the signal mode from a degenerate parametric oscillator. The probability of finding an even number of photons is greater than the probability of finding an odd number of photons for the light produced by a degenerate three-level laser. This is because the photons are always generated in pairs and the existence of some finite probability to find an odd number of photons is due to damping of the cavity mode. On the other hand, the distribution function for a coherently prepared nondegenerate three-level laser has the same form as the distribution function for the signal mode from a nondegenerate parametric oscillator. We have also seen that the photon number distribution in both cases decreases with the photon number.

REFERENCES

- [1] J. P. Gordon, H. J. Zeiger, and C. H. Townes, *Phys. Rev.* 95, 282 (1954).
- [2] A. L. Schawlow and C. H. Townes, *Phys. Rev.* 112, 40 (1958).
- [3] A. M. Prokhorov, *Sov. Phys. JETP* 34, 1658 (1958).
- [4] D. F. Walls, *Nature* 306, 141 (1983).
- [5] D. Stoler, *Phys. Rev. D* 1, 3217 (1970).
- [6] H. P. Yuen, *Phys. Rev. A* 13, 2226 (1976).
- [7] J. N. Hollenhorst, *Phys. Rev. D* 19, 1669 (1979).
- [8] Min Xiao, Ling-An Wu, and H. J. Kimble, *Phys. Rev. Lett.* 59, 278 (1987).
- [9] G. J. Milburn and D. F. Walls, *Opt. Commun.* 39, 401 (1981).
- [10] L. A. Lugiato and G. Strini, *Opt. Commun.* 41, 67 (1982).
- [11] M. J. Collett and C. W. Gardiner, *Phys. Rev. A* 30, 1386 (1984).
- [12] J. Anwar and M. S. Zubairy, *Phys. Rev. A* 45, 1804 (1992).
- [13] B. Daniel and K. Fesseha, *Opt. Commun.* 151, 384 (1998).
- [14] C. M. Caves, *Phys. Rev. D* 23, 1693 (1981).
- [15] See, for example, K. Zaheer and M. S. Zubairy, in *Advances in Atomic and Molecular and optical physics*, edited by D. R. Bates and B. Bederson (Academic, Newyork, 1990), vol. 28, p.143.
- [16] M. O. Scully, K. Wodkiewicz, M. S. Zubairy, J. Bergou, N. Lu, and J. Meyer ter Vehn, *Phys. Rev. Lett.* 60, 1832 (1988).
- [17] N. A. Ansari, *Phys. Rev. A* 48, 4686 (1993).
- [18] K. Fesseha, *Phys. Rev. A* 63, 033811-1 (2001).
- [19] K. Fesseha, "*Fundamentals of Quantum Optics*" (to be published).