

EPIDEMIOLOGY OF SCHISTOSOMIASIS
IN BAHIR DAR

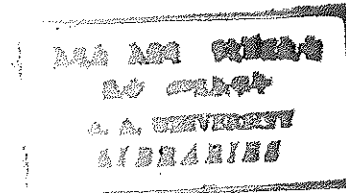

A THESIS

Presented to the
School of Graduate Studies
Addis Ababa University

In Partial Fulfillment
of the Requirements for the Degree
of Master of Science in
Biology

By

Berhanu Erko

June, 1988

ACKNOWLEDGEMENTS

I am greatly indebted to Dr. Shibru Tedla, my research advisor, for identification of the research problem and his unreserved help and guidance in the course of the study.

I am grateful to Dr. Beyene Petros, head of Department of Biology, Addis Ababa University, for his worthwhile criticisms and the pains he took in commenting on the work and final draft of the paper.

This paper would not have assumed its present form without his help.

I am very grateful to the co-operative staff of the Institute of Pathobiology in general and to Ato Fekadu Abebe, Ato Hailu Birrie and Ato Tufa Abate in particular for their constructive suggestions and material assistance in the course of the study.

I would like to acknowledge with thanks the assistance of Ato Ammasu Fantahun, student Erkie Sintayaw, Ato Getachew Haile and student Mulugeta Teshale in snail sampling, stool specimen collection and water contact observations.

Due thanks go to Ato Negash Gemeda and Ato Tesgaye Moge of the Institute of Pathobiology for assisting in mice ~~perfusion~~ and processing of stool specimens for microscopic examination, respectively.

I am also thankful to Ato Mekonnen Anega of the Biology Department, Addis Ababa University, for microscopic examination of stool specimens.

It is also a pleasure for me to acknowledge W/t Fikerte Tulu and W/t Belaynesh Brile for typing the first and final drafts of the paper, respectively.

I would also like to thank Ato Anketse-Berhan Kiflu-Gebre, Ato Belay Guta, Ato Italo Berisso, Ato Mekuria Lakew, Ato Merha-Tebeb Bezabih, Ato Muluneh w/Tsadik, Ato Paulos Gutema, W/t Roman Zewdie, Ato Tadesse Chali, Ato Teketel Yohannes, Ato Workneh Gobena and other colleagues and friends who helped and contributed to the work in various ways.

Finally, I would like to express my gratitude to the Swedish Agency for Research and Cooperation with the Developing Countries (SAREC) and Addis Ababa University for covering the expenses incurred in this study.

TABLE OF CONTENTS

	<u>PAGE</u>
ACKNOWLEDGEMENTS	i
TABLE OF CONTENTS	iii
LIST OF TABLES	iv
LIST OF FIGURES	v
ABSTRACT	vi
INTRODUCTION	1
MATERIALS AND METHODS	13
The study area	13
Parasitological methods	14
Parasitological studies	15
Prevalence studies	15
Incidence studies	15
Malacological studies	17
Transmission studies	20
Water contact studies	20
Statistical analysis	21
RESULTS	22
Parasitological findings	22
Malacological findings	27
Sentinel-mouse immersion results	32
Water contact observations	32
DISCUSSION	40
CONCLUSION	50
REFERENCES	52
APPENDICES	64

LIST OF TABLES

	<u>PAGE</u>
Table 1: Prevalence and intensity of <u>Schistosoma mansoni</u> infection by age and sex among residents of Kebeles 8, 9 and 10, in Bahir Lar.....	23
Table 2: Prevalence and intensity of <u>S. mansoni</u> infection by age and sex among children of Dil Chibo and Sertse Lengel elementary schools	26
Table 3: Incidence of schistosomiasis mansoni among children aged 6-10 years in Dil Chibo and Sertse Lengel elementary Schools, March, 1987-February, 1988	28
Table 4: Sentinel-mouse immersion results	33
Table 5: Water contact activities by age and sex, July, 1987 (rainy season).....	34
Table 6: Water contact activities by age and sex, December, 1987(dry season)	35
Table 7: Diurnal variation in frequency of water contacts..	36

LIST OF FIGURES

	<u>PAGE</u>
Figure 1: A partial sketch-map of Bahir Dar town showing sites of parasitological, malacological, transmission and human-water contact studies	16
Figure 2: Scoop used for sampling snails	19
Figure 3: Flooting cage for exposing mice to the lake and river waters.....	19
Figure 4: Correlation between prevalence and intensity of schistosomiasis (data from combined results of kebeles 8,9 and 10 in Bahir Dar).....	25
Figure 5: The bimonthly fluctuation in the number of <u>Biomphalaria pfeifferi</u> snails and associated <u>S. mansoni</u> infection in <u>B. pfeifferi</u> together with the monthly rainfall and temperature.....	30

■ V ■
ABSTRACT

Various aspects of the epidemiology of schistosomiasis mansoni were studied for a period of one year at Bahir Dar with the prime objective of elucidating the transmission patterns.

Parasitological surveys revealed an overall prevalence of 12% among residents of Kebeles 8, 9 and 10. More males (17%) than females (8%) were infected ($P < 0.01$). The overall prevalence for school children of Dil Chibo and Sertse Dengel were 32% and 45%, respectively. School children yielded high annual incidence at the second survey (February). Malacological findings suggested that Biomphalaria pfeifferi snails peaked in density in September, towards the end of the rainy season in Lake Tana and in January, around the middle of the dry season at a site on the bank of the River Abay. In September, infected snails were recovered from all collection sites. Schistosome infection also developed in a relatively large number of mice immersed in the month of September. In two series of surveys, the major water contact activities were identified and it was observed that there were diurnal and seasonal variations in these activities.

The study in general revealed that infection rates depend on age, sex and geographical location with respect to water body. Snail population dynamics and associated schistosomal infection seem to depend on rainfall and associated ecological changes. Incidence studies, malacological findings and sentinel - mouse exposure results suggest that the main transmission season in Lake Tana is towards the end and after rainy season. Intermittent transmission may also take place throughout the year. Diurnal and seasonal variations in human-water contact behaviours such as playing in water of children, bathing and swimming appear to have epidemiological significance in the transmission of schistosomiasis.

INTRODUCTION

In a broad sense, epidemiology can be defined as the study of the distribution and determinants of diseases and injuries in human populations (Mausner and Kramer, 1985). Discussing the epidemiological study of schistosomiasis, Jordan and Webbe (1982) pointed out that it involves snail intermediate hosts, vertebrate hosts and the many factors that may influence the common environment of these hosts and the parasite. Thus, a profound understanding of schistosomiasis epidemiology seems to depend on the study of all transmission factors of the disease.

The principal schistosome species that cause human schistosomiasis are, Schistosoma haematobium, S. mansoni, S. japonicum, S. intercalatum and S. mekongi (WHO, 1985). Other species such as S. mattheei, S. rodhaini, S. bovis and S. margrebowiei occasionally infect humans in parts of Africa (Cheesbrough, 1987).

Schistosoma haematobium primarily occurs in Africa and South - West Asia with a small focus in India. S. mansoni is distributed in parts of Africa, Southwest Asia and Central and South America (Wright, 1973). S. japonicum is endemic in China, Thailand, India, Indonesia, Japan and other Far East countries (WHO, 1985). S. mekongi is found in Laos, Kampuchea and Thailand in the Mekong River Basin (Cheesbrough, 1987). S. intercalatum is limited in distribution to west and Central African countries such as Zaire (Wolfe, 1974), Cameroon (Deschiens et al., 1969) and Nigeria (Wright et al., 1972).

Schistosomes require snail intermediate hosts of some kind or another for completion of their life cycle. In Africa, intermediate snail hosts of S. mansoni and S. rodhaini are species of the genus Biomphalaria (Brown, 1980). These snails are widely distributed

and are represented by four species groups, namely, the pfeifferi group, the alexanderina group, the choanoamphala group and the suganica group (Mandahl - Barth, 1958).

In America, three species of the genus Biomphalaria, that is, B. glabrata, B. straminea and B. tenagophila serve as intermediate hosts for S. mansoni (WHO, 1980). However, the most common intermediate host in this locus is B. glabrata.

For S. haematobium, S. intercalatum and other zoonotic species such as S. bovis, S. mattheei and S. margrebowiei which rarely infect humans, the snail hosts are species of Bulinus (Brown, 1980).

The snail hosts of S. japonicum and S. mekongi are certain species of the genus Oncomelania and Tricula aperta, respectively (Vogel et al., 1972). The distributional pattern of snails and the fluctuation in their density are governed by ecological factors which condition the habitat. Generally, snails are said to have capability of tolerating different chemical and physical factors within very wide limits (Webbe, 1982). According to Malek (1958), the stability of snail habitats is conditioned by food, oxygen, sunlight and water quality, Malek (1962) described that the current velocity, nonpermanence of the habitat, silt content of the water, temperature and density of aquatic weeds and algae have bearing on snails population. On the other hand, Berrie (1970) pointed to water temperature, organic content of the water body and light penetratin. Detailed explanation on the effect of each of this factor on the snail population was also given by WHO(1957) and Watson (1958).

Of abiotic and biotic factors, snail population dynamics is more influenced by the former(Southwood, 1977). The two abiotic factors which have considerable influence on snail populations are rainfall,

and temperature (Appleton, 1970). Snails in notably dry areas with wet/dry seasonal climates build up their population during the dry season and are flushed of their stream habitat during the rainy season. These climatic effects have been reported from different countries (Webbe, 1960; Cridland, 1958; Webbe and Msangi, 1968; Barbosa, 1962; Hairston, 1973; Sodeman, 1979).

In areas where rainfall, water levels, and temperature are relatively constant, there are no pronounced cyclic changes and reproduction may take place throughout the year (Webbe, 1965). Nevertheless, Ritchie et al. (1962) and Webbe (1965) have pointed out the possibility of irregular population changes independent of external factors by intrinsically operating factors such as birth rate, natural mortality and environmental resistance. Furthermore, Webbe (1964) described that factors which condition the habitats of snail are apparently multiple and act together rather than individually. Therefore, it seems that the effects of factors, other than rainfall and temperature on the snail density and distribution appear to be of no less significance.

Maintenance of successful transmission of schistosomiasis involves three unrelated animal species, namely, a molluscan intermediate host, a vertebrate definitive host and the parasite focusing on a common transmission site (Sturrock, 1986).

For establishment of infection in vector snails, schistosome eggs necessarily have to reach the habitat of susceptible snails. The eggs are either directly deposited in water or they are transported to the habitat from where they have been deposited. Obvious routes by which the ova reach snail infested water are direct defecation into the water, that is, from latrines built over rivers or canals

as in the Far East and from a bridge over a river as in St. Lucia (Jordan et al., 1980).

For S. haematobium, the most common route of contamination is direct micturation into the water (Jordan and Webbe, 1982).

Christie and Upatham (1977) described that the greatest amount of contamination is from faecal matter deposited behind bushes or in tall grass on river banks. This leads to increase in infection rates of snails with the onset of rains. The washing of faecally contaminated clothing (Chernin and Antolics, 1973) and faecally soiled hands (Jordan et al., 1980) may lead to the introduction of eggs into the water. The habits of cleansing of perianal faecal soiling while bathing (Husting, 1965; Prentice et al., 1970) and washing of perianal region practices among Muslim males after defecation may also add small numbers of schistosome eggs to water (Jordan and Webbe, 1982). In some situations, sewage may be the source of contamination (Rowan, 1964).

The numerous animals definitive hosts of Schistosoma japonicum and of less importance, those of S. mansoni, add to the contamination of snail habitats with eggs of those worms (Jordan et al., 1980).

Following the contamination of snail habitats with schistosome eggs, the majority of these eggs will hatch with the emergence of free living miracidia. Among physical factors which affect the hatchability of the eggs lie light, temperature and hydrogen ion concentration (Ingalls, cited by Hairston, 1973). After hatching, the continuity of the parasites' life cycle depends on the miracidial finding and infecting of appropriate snail hosts.

The proportion of snails infected with schistosomes at any given time depends upon a complex interaction of factors. The most

important of these factors are the distribution and behaviour of definitive hosts, the relative susceptibility to infection of the strain of intermediate host and such climatic factors as temperature and rainfall (Hariston, 1973). According to Christensen(1980), increasing water velocity, increasing water volume, increasing water depth and decreasing snail density reduce miracidial host finding. Other factors which influence the infection of snails by miracidia are the age of snails and miracidia, the number of miracidia per snail, dispersion of snails and miracidia, the length of contact time, water turbulence and ultraviolet light(Cited by Webbe,1982).

Flowing water is of considerable significance in the epidemiology of schistosomiasis for distributing infective miracidia over appreciable distances (Jordan and Webbe, 1982). Upatham(1973) recorded successful host finding by the S.mansoni miracidium at a distance of 97.54 meters down stream in moderately flowing water. Webbe(1966) and Upatham (1973) described that moderately flowing water increases the scanning capacity and potential contact with snail intermediate hosts. Webbe(1966) has demonstrated the effect of water velocities on the infection of Biomphalaria sudanica tanganyicensis exposed to S. mansoni miracidia in experimental flowing water system. When snails were exposed to 1- 50 miracidia per snail at water velocity of 0.15- 1.07 m/second for more than one hour, high infection rates were recorded in all except in the snails exposed to about 1 miracidium per snail. However, how far these experimental findings can be extrapolated to infection under natural condition have not been confirmed. On the other hand, Upatham(1973) described that host location takes place at flow rates of or below 10cm/second and miracidia can rarely find their

hosts above these level. According to Jordan and Webbe(1982), snails may be successfully infected at any water velocity they can withstand, although most infections probably occur in the relatively sheltered conditions of the microhabitats provided along the margins of streams, in pools or within vegetation.

Upatham(1972) demonstrated that factors such as hydrogen ion concentration outside the range of 6 - 9, NaCl concentration above 4200 ppm and high turbidity reduce the infectivity of S. mansoni miracidia. On the other hand, Malek (1958) found that undernourished snails harbour fewer parasites and also that the development of sporocyst is inhibited. Purnell (1966) showed that the infection rate in snails increases with increasing temperature up to the thermal death point of snails. This was demonstrated by DeWitt (1955) in Biomphalaria glabrata and B. sudanica tanganyicensis using S. mansoni miracidia. It was stated that temperature increases the activity of both miracidia and snails, thereby increasing the chance of contact (Berrie, 1970). By contrast, low temperature retards the metabolism of both the parasite and snail host(Stirewalt, 1954; DeWitt,1955). According to DeWitt(1955) and Prah and James (1977), lower temperature level at which snails are infected by S. mansoni and S. haematobium miracidia is 15 - 15°C, while the optimum is 25 - 35°C.

Temperature also affects the viability and hatchability of eggs (Ingall, 1949), miracidial transformation to cercaria (Foster, 1964) and the incubation period(Chu et al., 1966; Shattock et al., 1965), metabolism of the parasite and the host(Stirewalt,1954; DeWitt, 1955) and cercarial production (Shiff et al., 1975).

Cercariae emanating from vector snails infect humans when they come in contact with natural surface water during everyday activities

such as washing, bathing, fetching water and swimming. However, the possibility of transmission from water carried into houses for domestic uses have also been described (Polderman, 1974).

Water contact studies have been carried out in various schistosomiasis endemic countries (Pimentel et al., 1961; Farooq. et al., 1966; Farooq and Mallah, 1966; Dalton, 1976; Kloos and Lemma, 1980; Fenwick et al., 1982).

The studies are increasingly being given appreciation for a variety of reasons. They enable to pinpoint those human activities involving the greatest risk of exposure (Dalton and Pole, 1978). Furthermore, Jordan and Webbe (1982) described that water contact studies help answer questions relating to variations in egg output with age, the development and role of immunity; and that they can indicate the time and site of transmission when complemented with biological and parasitological studies.

According to Stoll (cited by Chandler, 1956), about 114 million people were victims of schistosomiasis in 1947 all over the world. After three years, this figure rose to 150 million (Halawani, 1959). Recently, it was estimated that schistosomiasis endemic areas extend over 74 tropical and subtropical countries (WHO, 1985). In these endemic regions of the world, about 1 billion people are at risk of schistosomiasis infection (Sturrock; 1986) and an estimated 250 million people suffer from the infection (Christensen et al., 1987).

The human host appears to solely contribute to the drastic increment. Mott (1984) states that " Schistosomiasis is caused by people-not snail

Such a view can be seen from two perspectives. Firstly, poor human sanitary habits lead to the pollution of snail habitats with the parasite eggs and hence snail infection from which cercariae emanate to infect the human host. Secondly, because of inadequate planning of irrigation schemes or man made lakes, new breeding grounds will be available for snail intermediate hosts, and hence expansion of schistosomiasis foci. The second situation greatly enhances the spread of the disease especially with the increasing use of freshwater resources to feed the exploding human population.

The awareness of the endemicity of schistosomiasis in Ethiopia dates back to the time of Italian invasion. However, regarding its history, authorities differ in their views. Some assumed schistosomiasis to be of recent problem introduced from countries such as Saudi Arabia (Ayađ, 1956; Lemma, 1969). On the other hand, Kloos et al., (1978) considered it to be of antiquity and believed that the parasite existed in isolated areas such as the Blue Nile Gorge, Lake Tana area and the Mui Valley.

Ayađ (1956) by reviewing available Italian literature up to 1952 and from his own work concluded that schistosomiasis mansoni infection was endemic in Lake Tana region, Eritrea, Gondar and Hararghe. Subsequently, Chang (1961), Zaphiropoulos (1963), Kubasta (1964) and Lo et al., (1973), among others, confirmed the endemicity of this disease as reported by Ayađ (1956). Yiman (1964) first reported 10 cases of schistosomiasis mansoni at Wonji. But he assumed them to be imported. Duncan and Lemma (1976) and Tekelehaimanot and Goll (1978) further proved the transmission of schistosomiasis mansoni in this same focus. Buck et al., (1965) and Lemma (1965) showed that

schistosomiasis mansoni is also highly endemic in Aqwa, Tigray Administrative region. Fuller et al., (1979) demonstrated that schistosomiasis mansoni infection is well established in the Omo basin and its tributaries. Gundersen and Birrie (1982) investigated the distribution of human infection with S. mansoni in Mendi District, Wollega Region. Birrie (1986) surveyed the Borkena River Basin for S. mansoni and its snail intermediate hosts. Eshete (1987) reported 12.4% infection prevalence of schistosomiasis mansoni cases among Anuak ethnic group in Western Ethiopia.

Unlike schistosomiasis mansoni which has a wider geographical range in Ethiopia, Schistosomiasis haematobium has limited geographical distribution (Kloos et al., 1978; McConnell and Armstrong, 1976). Generally it is said that schistosomiasis haematobium is endemic in the lowlands and schistosomiasis mansoni occurs in the highlands of Ethiopia.

Ayad (1956) reported two cases of schistosomiasis haematobium at Gewani in the Middle Awash Valley. Russel (1958) gave conclusive evidence of the endemicity of schistosomiasis haematobium in this region and in Ethiopia as a whole. Subsequently, this was confirmed by Lemma (1969). Regarding the history of schistosomiasis in the Awash Valley, Lemma believed that this infection was imported from the highlands of Ethiopia when people moved to the low lands of Awash in search of jobs and better opportunities.

The endemicity of urinary schistosomiasis at Wabi Shebele flood - Plain, Eastern Ethiopia, was reported by De Sole et al. (1978). Ali et al. (1986) reported for the first time high infection rate

of schistosomiasis haematobium from Kurmuk, Wollega Region in the Western boarder of Ethiopia.

Reports from all 14 administrative regions of Ethiopia have shown that the number of reported schistomiasis cases increased from 1024 cases in 1972 to 21801 in 1976 (Institute of Pathobiology, 1980). Nevertheless, to what extent these figures are correct representations of the actual cases is questionable because, systematically collected and representative data from which the conclusion was drawn is not presented.

Recently, based on the countrywide survey carried out from 1978 to 1982, Ayele (1982) reported the occurence of infection due to schistosomiasis mansoni in 136 communities of the 216 surveyed and an infection rate 6.2% for schistosomiasis haematobium in 17 communities examined. He also estimated that 14 million and 3 million people are living in risk areas for schistomiasis mansoni and schistosomiasis haematobium infections, respectively in Ethiopia.

The fact that new schistosomiasis foci are being described may be an indication of the spread of the disease to the new areas previously free of schistosomiasis and/or it may be the discovery of the already established schistosomiasis foci following the introduction of community services such as health services and road constructions to the rural and remote areas of the country.

With regards to malacology, our current knowledge of schistosome intermediate snail hosts in Ethiopia is based upon malacological investigations made by various workers. The results of these studies have been summarized by Lo et al.(1988). This review also describes the taxonomic status of the snail hosts.

In the Awash Valley, the intermediate snail host for S. haematobium was shown to be Bulinus abyssinicus (Lo, 1970). In the Wabi Shebele Valley, the snail host is not known (De Sole et al., 1978). For the recently found S. haematobium focus, Kumuruk in Western Wollega, the snail host is B. africanus (Ali et al., 1986). Snail intermediate hosts for S. mansoni are Biomphalaria pfeifferi and B. sudanica.

Control efforts of schistosomiasis have been made at Adwa and Wonji and Shoa sugar estates. In Adwa it was possible to reduce prevalence of infection from 62.5% to 36.4% after 5 years application of local streams with enoc (Powdered berries of the plant Phytolacca dodecandra) (Goll et al., 1983). However, because of discontinuation of the programme, control has not materialized. Control efforts made at Wonji using Fresion (N - tritylmorpholine) and Bayluscide (niclosamide) also have not been successful for the same reason as that of Adwa (Teklehaimanot and Goll, 1978). Investigation on the disruption of bilharzia transmission was also made in the Kurtume flood plain of the Awash Valley (Haile - Meskel et al., 1981).

To prevent further expansion or to eradicate schistosomiasis in Ethiopia, a systematic schistosomiasis control programme to be implemented by the health services has not yet been formulated. However, according to Lo et al. (1988), a national schistosomiasis control programme is now being developed based on the epidemiology and geographic distribution of schistosomiasis and its intermediate hosts. The programme is facilitated by the restructuring of the Malaria Control Programme to include schistosomiasis and other vector-borne diseases.

With regard to schistosomiasis mansoni in Lake Tana, its endemicity is well established. However, the surveys of this disease made at Lake Tana shore in Bahir Dar (Ayad, 1956; Ayele et al., 1986) were sketchy, time limited and mainly focused on the prevalence of infection. With respect to longitudinal patterns of transmission dynamics of schistosomiasis, no study has been undertaken to date. The general objective of the present study was , therefore, to elucidate transmission patterns of schistosomiasis mansoni in the town of Bahir Dar. Specific objectives were to assess indices of human infection in the study population; to find out changes in the snail population and associated schistosomal infection in the snail hosts with time; to identify important water contact activities; and to establish the time-scale of transmission in this endemic focus.

Unlike the previous surveys conducted in the region, the present study considers more epidemiological parameters. Hence, it is hoped that the fulfillment of these objectives may provide base-line data for the future control strategy to be instituted in this focus.

* * *

MATERIALS AND METHODS

The Study area

Bahir Dar is a lake - port town located in Gojjam administrative region in the north western part of Ethiopia. It is geographically located almost on the border-line of Gojjam and Gondar administrative regions somewhere at the southern most part of Lake Tana, the source of the River Abay (The Blue Nile). More specifically, the town of Bahir Dar is located at $11^{\circ}33'N$ and $37^{\circ}24'E$. It has a direct access both to the water of Lake Tana and to the very upper most course of the River Abay.

Bahir Dar is one of the most important urban centers in the north western region of the country and a notable tourist center. It has some 320 and 490 kilometers air and ground distances, respectively, from the capital city of the country, Addis Ababa. The town is not only an important political and economic center but also has a significant population concentration. It had a total population of 61,310 as of June 1987. Of this 27,238 and 33,392, respectively were males and females. It is one of the towns of the country which is considered fast growing for its population has doubled within the past 10 years, with a growth rate of more than 5 per cent, which is more than the national average. With regards to the health services, there is one hospital, one health center and five pharmacies in the town. According to the 1987 study entitled " Basic physical and social Infrastructure Profiles of Bahir Dar, " the most prevalent diseases among the adult population were, in order of severity, intestinal parasites (Particularly Schistosoma mansoni), tuberculosis, obstetric complications and traumatic obstacles, that is, asthma and cardiovascular diseases. Among the children, the worst diseases were malnutrition, gastro - enteritis,

measels and whooping cough (Ministry of Health, 1987).

Much of the prevalent illness is in part due to lack of sanitary facilities. There is no sewerage system. The majority of housing units have no toilet facilities of any kind. The houses are not screened that flies and other diseases carrying insects breed freely and contribute to the spread of diseases.

Parasitological methods

The parasitological method employed was Kato technique modified by Peters et al. (1980). To collect stool specimens from the subjects, big roll of thin plastic was cut into pieces and distributed out to the subjects by assistants of the researcher at Kebeles' offices. The faecal material being placed on a piece of plastic was pressed through a stainless steel sieve (mesh size 105) to remove coarse fibres and large solid particles. The sieved stools were scraped with a wooden tongue depressor and applied to the hole (6.5 mm diameter) in the aluminium template delivering 20 mg plug of sample. With careful removal of the template, a 20 mg plug of faeces was left on the slide. On this plug, a 25 x 35 mm glycerol - malachite green - impregnated cellophane coverslip was pressed thereby creating a thin disk of stool for examination. Two Kato slides were prepared from one stool specimen and each was read twice by the same technician at the Institute of Pathobiology. Egg counts were made only for Schistosoma mansoni, that is, the ova of other helminthes were not quantitated ; only their presence was noted. The intensity of infection was expressed as the geometric mean of egg counts.

Parasitological studies

Prevalence studies. Stool specimens were collected from residents of Kebeles 8,9 and 10 and school children of Dil Chibo and Sertse Dengel elementary Schools(Fig.1). Residents of Kebele 10 have access to both the River Abay and Lake Tana, but prefer using river water for all activities and purposes. Residents of Kebele 9 have access only to the River Abay, whereas those of kebele 8 are far from both water bodies.

After getting information on the number of households and family size from kebeles' offices, 20 per cent systematic random surveys of the total households were made for each of the three kebeles.

All members of the selected households were told by Kebele office bearers to come to kebeles' offices in the morning in order to provide stool specimens. The number of subjects sampled from each kebele is shown in Table 1. For measuring S. mansoni infection rates among the school children, lists of students from grade 1-6 were obtained from the teachers in Dil Chibo and Sertse Dengel schools and 20 per cent systematic random sampling was selected. Thus, 331 students in Dil Chibo and 394 students in Sertse Dengel schools were selected for the study (Table 2).

At the time of stool specimen collection, every individual subjected to the stool examination was interviewed by the researcher and his assistants about his/her age, sex, the place where each person had been living previously prior to coming to Bahir Dar, religion, occupation, water contact activities and source of household water supply.

Incidence studies. For incidence measurement, school children in the two schools who were found to be negative at the original parasitological survey carried out for prevalence determination and who were 6 to 10 years were used. Accordingly, 171 children

Fig.1. A partial sketch-map of Bahir Dar town showing sites of parasitological, malacological, transmission and human-water contact studies.

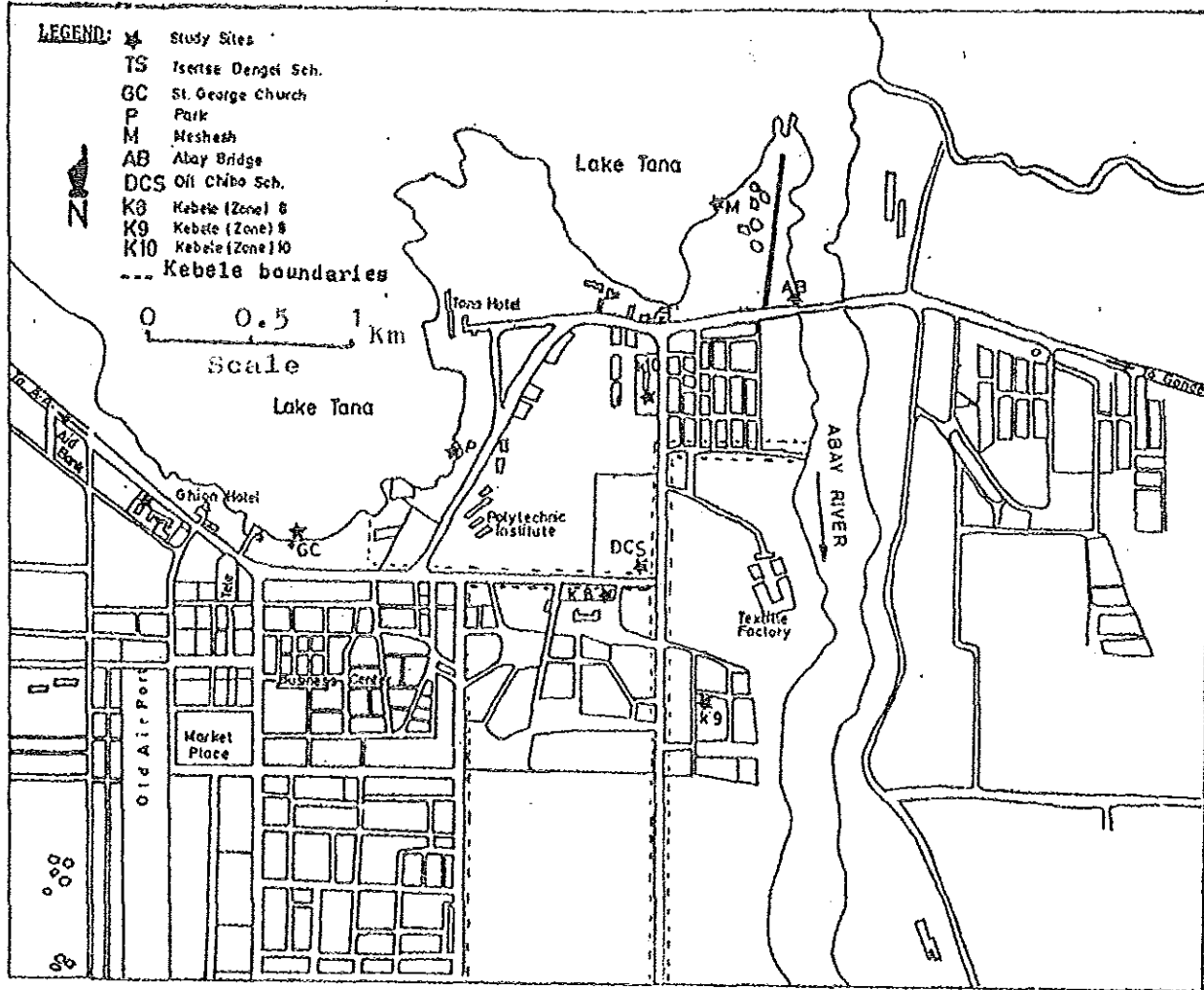

Source:

Adopted from Water Supply and Sewerage Authority, Oct. 1982. Bahir Dar, Feasibility Study for water supply. Final report, Fig.5.1.

from Lil Chibo and 106 children from Sertse Dengel elementary schools were studied. Incidence surveys were carried out at six months interval for a period of one year. Annual incidence was calculated using a formula described by Farooq and Hairston (1966), that is, $I = 1 - X^{12/Y}$, where I is annual incidence and X is the proportion remaining negative for Y months.

Malacological studies

Snail surveys, like all other aspects of the study, were commenced in March 1987 and terminated in February, 1988. Snail collections were carried out at four human water contact sites identified after making observations on human water contact activities. The sites were Meshesh (M), beneath the Abay river bridge (AB), near the Polytechnic Institute (P) and near the Saint George Church(GC) (Fig.1). Except site AB which is situated on the Abay River bank, the rest are along Lake Tana.

Bimonthly snail collections took place at the selected sites by a method suited to a particular site as the type of water body determines the sampling method (Sturrock, 1986). At almost all sides of the lake, sparse littoral vegetation grew and was interspersed with big rocks. In such habitats, collections were made by handpicking (sites P and GC). While handpicking, forceps and gloves were used to avoid direct contact with the potentially cercariae - infested water. The bimonthly handpicking and forceps collections were done for 2 hours at each site.

Site M alongside Lake Tana and site AB on the bank of the River Abay had relatively few scattered rocks and dense vegetation that

snails could not be visible to the naked eye thereby necessitating for the blind pass of a standard scoop (Fig. 2) and scooping time of 30 minutes.

During collection, care was taken that the same persons were used to collect the snails systematically and with uniform speed at the same site throughout the collection period. All snails were collected in morning hours.

The snails collected were immediately carried to the Bahir Dar Teachers' College Biology laboratory on the day of collection. Detailed information of size and cercarial infection rate were obtained only for Biomohalaria pfeifferi snails. The maximum diameter of the shell was measured to the nearest millimeter using a plastic ruler fixed on the top of the laboratory table. Crushing and shedding were employed to check for cercarial infections. Immediately after collection, around noon, snails were placed individually in glass tubes of about 10 ml capacity containing clear pond water. They were exposed for 4 hours to artificial light source in the laboratory. The emanating cercariae, if any, were observed using hand lense or microscope. Snails which did not shed cercariae were examined by crushing. Snails were crushed between two microscope slides and the cercariae were searched for in tissues under a dissecting microscope or low power microscope objective by the researcher. Although much attention was paid to human schistosome cercariae, the presence of other cercariae such as furcocercous - longifurcate cercariae and xiphidiocercariae was noted.

Meteorological data from March, 1987 to February, 1988, that is, monthly air temperatures and rainfall were provided by the Meteorology station situated in Bahir Dar town.

Figure 2. Scoop used for sampling snails.

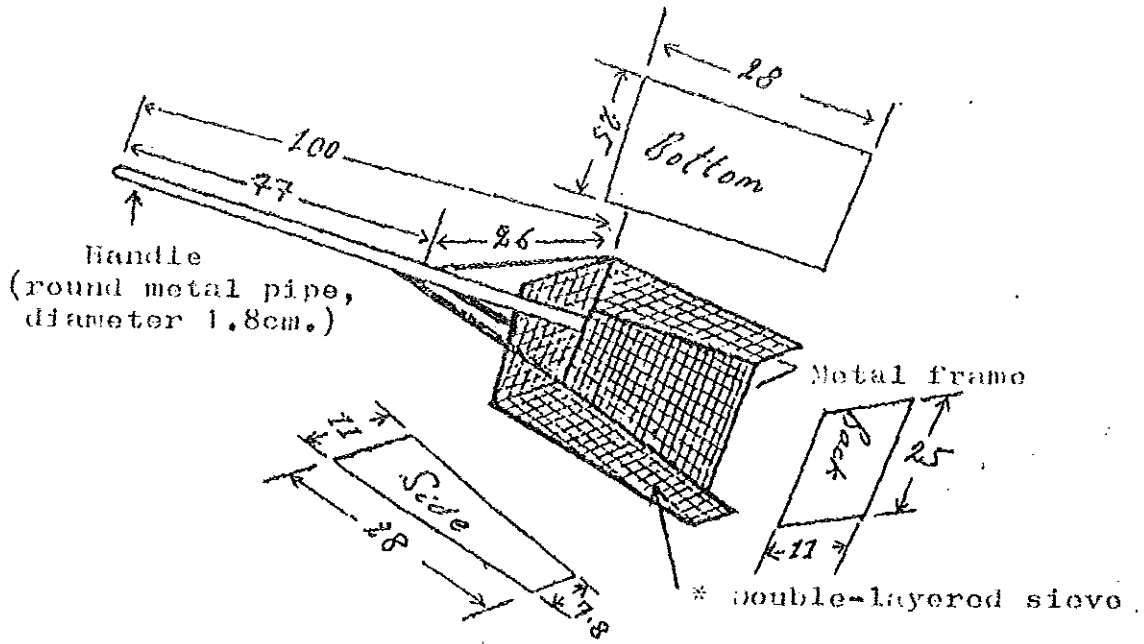

- * Opening of inner sieve = 0.2 cm²
- Opening of outer sieve = 0.4 cm²

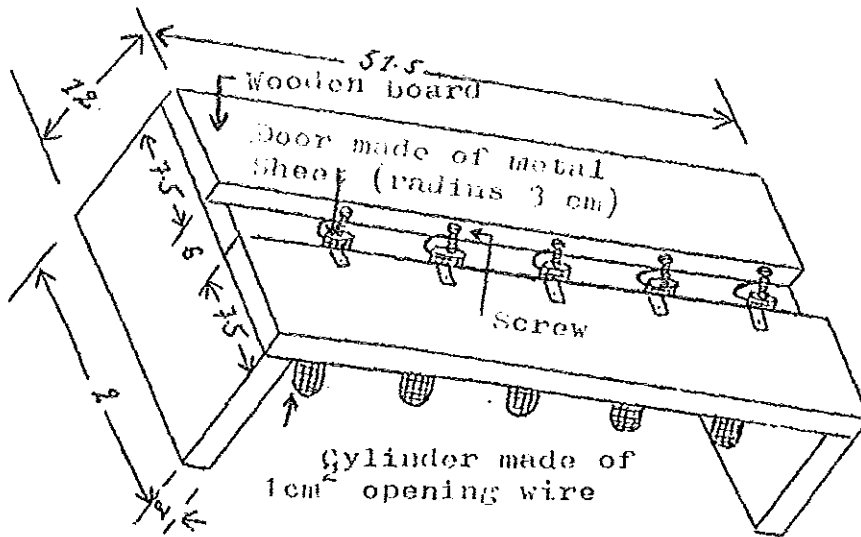

Fig. 3. Floating cage for exposing mice to the lake and river waters.

N.B. All dimensions are in cm.

At each visit to each collection site, the physical characteristics (water level, water velocity and vegetation) of the site were briefly noted without carrying measurements.

Transmission studies

The Swiss albino strain of Mus musculus mice used in the transmission studies were purchased from the National Research Institute of Health, Addis Ababa. Mice immersion took place every two months at each of the 4 water contact sites in groups of 5 using 4 floating cages (see Fig.3) for 2 hours between 10:00 a.m. and 12 a.m. After 6 weeks laboratory maintenance at Bahir Dar Teachers' College biology laboratory, the mice were transported to the Institute of Pathobiology, Addis Ababa, to be sacrificed for the recovery of adult worms by the perfusion method following the procedure described by Duval and Lewitt (1967).

Water contact studies

Water contact studies were initially carried out at all selected human - water contact points for 4 days to obtain an overall view of activities, age and sex distribution of the users at each site. But, quantitative water contact observations were continued only at site AB after it became clearer that there was no clustering of water contact activity at any one point. Site P was fenced for recreation and assigned guards 8 months after the commencement of the study. However, observations have shown that some intruders washed clothes, swam and bathed when guards were not around.

At human water contact point AB, 2 series of water contact observations were made. The first series of observations was made in the rainy season (July, 1987) and the second in the dry season (December, 1987) for seven consecutive days from 6:30 a.m. to 6:30 p.m. Hence, the data included in this paper is based on observations made at water contact site AB.

To accomplish this aspect of the study, forms were prepared by the researcher with details of major water related activities at human - water contact sites, sex and age groups in years (Appendix I). To determine duration of exposure (contact) and diurnal variations of water contact activities, forms portrayed in Appendices II and III were used, respectively.

For noting all activities going on at the 4 human - water contact sites, 4 local students trained by the researcher were used. The students were trained on how to fill the forms. Each of the 4 students were placed at one water contact site and they recorded all human - water contact activities by type of activity, time of entry into and exit from the water, age and sex of the users. The researcher supervised the observers during each water contact survey.

Statistical analysis

To test for the significance of difference in incidence between schools and the significance of difference in prevalence between schools, kebeles and sexes, χ^2 - test was used (Snedecor and Cochran, 1967). Also, graphs and tables were used in the analysis.

RESULTS

Parasitological findings

Results of stool examination of individual kebeles are summarized in Table 1. The overall prevalence of infection for residents of kebeles 8, 9 and 10 was 12%. More males (17%) than females (8%) were infected. This difference is statistically significant at 0.01 level. In none of kebeles were any Schistosoma mansoni infections found in the age 0 - 4 years. The peak prevalence of infection in both sexes (23%) occurred in the 10 - 14 years age group. Prevalence declined after age group 10 - 14 years. However, little rise in prevalence was evidenced in the subjects of 60 and above years. Intensity of infection shows a similar pattern of age variation as prevalence (Fig.4).

The prevalence of S. mansoni in Sertse Dengel school was 45% and that in Dil Chibo school 32%. This difference is statistically significant at 0.01 level. Males had higher prevalence of infection than females ———42% for males and 18% for females in Dil Chibo school and 51% for males and 37% for females in Sertse Dengel school. The highest geometric mean egg count was obtained for the age group 10 - 14 years, followed by age group 5 - 9 years, and then by age group 15 - 19 years. This pattern closely corresponds with the age link prevalence (Table 2). Interviews made with both nonschool and school populations at the time of stool specimen collection showed that about 96.6% of the subjects in the sample had lived at least 7 years prior to the survey in Bahir Dar. This indicates that nearly all positive cases had acquired their infection in Bahir Dar.

Table 1: Prevalence and intensity of Schistosoma mansoni infection by age and sex among residents of Kebeles 8, 9 and 10 in Bahir Dar.

		Age Group in years									Total	
		0-4	5-9	10-14	15-19	20-29	30-39	40-49	50-59	60+		
Kebele 8	Male	No.Pos./No.examined	0/12	1/8	16/104	8/100	3/47	1/20	4/58	0/10	1/8	34/367
		% Positive	0	13	15	8	6	5	7	0	13	9
		*EPGS	0	136	173	85	75	50	57	0	50	89
	Female	No.Pos./No.examined	0/4	0/16	9/104	3/112	1/48	2/56	1/28	0/9	0/4	16/381
		% positive	0	0	9	3	2	4	4	0	0	4
		*EPGS	0	0	87	63	100	71	50	0	0	74
	Total	No.Pos./No.examined	0/16	1/24	25/208	11/212	4/95	3/76	5/86	0/19	1/12	50/748
		% positive	0	4	12	5	4	4	6	0	8	7
		*EPGS	0	136	130	74	88	61	54	0	50	85
Kebele 9	Male	No.Pos./No.examined	0/7	3/11	16/44	10/47	3/17	1/7	2/16	1/15	2/15	38/179
		% positive	0	27	36	21	18	14	13	7	13	21
		*EPGS	0	104	343	62	50	100	71	50	75	107
	Female	No.Pos./No.examined	0/14	1/16	9/20	11/44	2/88	3/48	3/32	0/9	0/4	29/275
		% positive	0	6	45	25	2	6	9	0	0	11
		*EPGS	0	50	110	81	71	75	86	0	0	79
	Total	No.Pos./No.examined	0/21	4/27	25/64	21/91	5/105	4/55	5/48	1/24	2/19	67/454
		% positive	0	15	39	23	5	7	10	4	11	15
		*EPGS	0	77	227	72	61	88	79	50	75	91

Table 1. Contd.

= 24 =

		Age group in years										
		0 - 4	5 - 9	10 - 14	15 - 19	20-29	30-39	40-49	50-59	60 +	Total	
Kebele 10	Male	No.Pos./No.examined	0/25	19/115	34/65	11/41	6/27	4/24	3/20	2/19	1/14	80/350
		% positive	0	17	52	27	22	17	15	11	7	23
		* EPGS	0	134	173	104	65	59	63	50	100	94
	Female	No.Pos./No.examined	0/14	10/92	13/85	4/58	4/65	3/51	2/40	2/32	3/30	41/467
		% positive	0	11	15	7	6	6	5	6	10	9
		* EPGS	0	127	283	173	50	63	71	100	63	116
	Total	No.Pos./No.examined	0/39	29/207	47/150	15/99	10/92	7/75	5/60	4/51	4/44	121/817
		% positive	0	14	31	15	11	9	8	8	9	15
		* EPGS	0	131	228	139	58	61	67	75	82	105
Kebeles 8, 9, and 10	Male	No.Pos./No.examined	0/44	23/134	66/213	29/188	12/91	6/51	9/94	3/44	4/37	152/896
		% positive	0	17	31	15	13	12	10	7	11	17
		* EPGS	0	125	230	84	63	70	64	50	75	95
	Female	No.Pos./No.examined	0/32	11/124	31/209	18/214	7/201	8/155	6/100	2/50	3/38	86/1123
		% positive	0	9	15	8	3	5	6	4	8	8
		* EPGS	0	89	160	106	74	70	69	75	63	89
	Total	No.Pos./No.examined	0/76	34/258	97/422	47/402	19/292	14/206	15/194	5/94	7/75	238/2019
		% Positive	0	13	23	12	7	7	8	5	9	12
		* EPGS	0	107	195	95	69	70	67	63	69	92

* EPGS : eggs per gram of stool

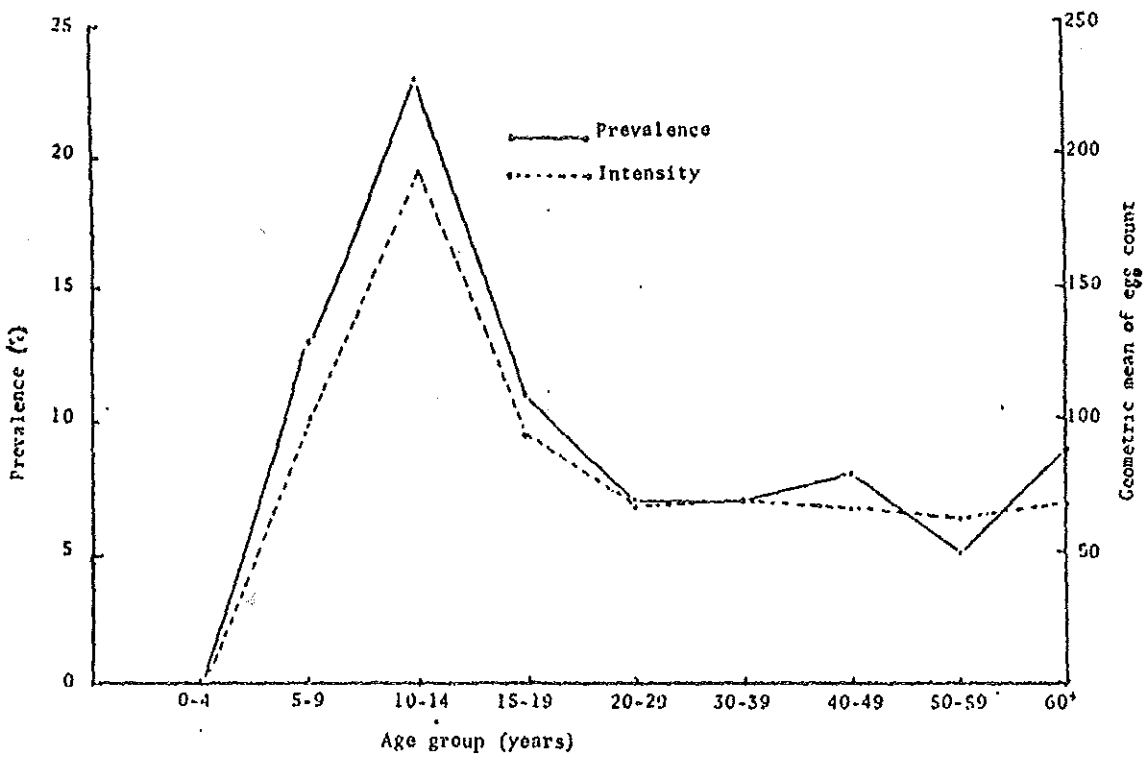

Fig.4. Correlation between prevalence and intensity of schistosomiasis (data from combined results of kebeles 8, 9 and 10, in Bahir Dar).

Table 2. Prevalence and intensity of S. mansoni infection by age and sex among children of Dil Chibo and Sertse Dengel elementary schools

		Age group in years				
		5-9	10-14	15-19	Total	
Dil Chibo School	Male	No. pos./No. examined	30/85	51/102	3/13	84/200
		% positive	35	50	23	42
		* EPGS	104	149	100	118
	Female	No. pos./No. examined	6/50	16/74	1/7	23/131
		% positive	12	22	14	18
		* EPGS	85	107	50	81
	Total	No. pos./No. examined	36/135	67/176	4/20	107/331
		% positive	27	38	20	32
		* EPGS	95	128	75	99
Sertse Dengel School	Male	No. pos./No. examined	21/69	86/130	7/25	114/224
		% positive	30	66	28	51
		* EPGS	199	281	136	205
	Female	No. pos./No. examined	21/64	34/85	8/21	63/170
		% positive	33	40	38	37
		* EPGS	158	209	96	154
	Total	No. pos./No. examined	42/133	120/215	15/46	177/394
		% positive	32	56	33	45
		* EPGS	179	245	116	180

* EPGS: eggs per gram of stool

Interviews further showed that more households in Kebeles 8 and 9 had piped water supply than kebele 10.

Examination for other intestinal helminthiases gave prevalence of 61.8% for ascariasis, 42% for trichuriasis, 36.5% for ancylostomiasis and 7% for taeniasis.

Incidence of schistosomiasis mansoni among children aged 6 - 10 years in Dil Chibo and Sertes Dengel schools is presented in Table 3. Incidence among children was slightly higher in Sertes Dengel school (3.7% and 5.7% at first and second surveys, respectively) than in Dil Chibo school (3.4% and 3.5% at first and second surveys, respectively), although this differences between the two schools are not statistically significant ($P < 0.01$).

Malacological findings

The number of snails collected bimonthly in the study sites, the number with cercarial infection and the monthly rainfall and temperature data are indicated graphically in Fig.5.

At site AB on the bank of the River Abay, Biomphalaria snails tended to decrease in number from March, 1987 to July, 1987 after which it started to gradually increase until density reached a peak in January 1988, around middle of the dry season.

At sites M, P and GC on the shore of Lake Tana, the patterns of change noted in population of B. pfeifferi were similar. From March, 1987 to May of that year, the number of snails collected was declining except at site M where no snails were collected in March because of complete drying of the habitat. From July,

Table 3. Incidence of schistomiasis mansoni among children aged 6-10 years in Dil Chibo and Sertse Denegel elementary schools, March, 1987 - February, 1988.

Age(years)	No. of children found negative					
	Dil Chibo school			Sertse Dengel school		
	Original	1 st incidence	2 nd incidence	Original	1 st incidence	2 nd incidence
	parasitologic survey (March, 1987)	survey (Sept.1987)	survey (Feb, 1988)	parasitologic survey (March,1987)	survey (Sept.1987)	survey (Feb. 1988)
6	8	8	8	11	11	11
7	5	5	5	14	14	14
8	35	35	35	5	5	4
9	68	67	66	29	28	28
10	55	53	51	47	46	44
Total	171	168	168	106	104	101
Annual Incidence		3.4%	3.5%		3.7%	5.7%

1987 to September of the same year, snails tended to increase in number and their density peaked in the months of September. After September, the number of snails collected bimonthly progressively declined until relatively few snails were collected in January, 1988.

Infected snails were collected from site GC in March, from site P in November and from all sites in September. In May and July 1987 and Jan., 1988 no infected snails were collected from any human - water contact sites. Water level, in both Lake Tana and the River Abay, attained its annual peak in August after which it started to decline gradually until the next rainy season. Although no measurement of the velocity was taken, observation indicated that the water of the River Abay attained maximum velocity in the rainy season and the flow rate decreased in the dry season. With the falling water level, the density of aquatic vegetation declined and many snails were seen stranded dead on rocks and vegetation. During collection, snails were mostly found associated with leaves of Ceratophyllum demersum L., and rarely with leaves and stem of Nymphaea caerulea Sav. and Cyperus papyrus L, other aquatic weeds, decaying wood and rocks.

The annual average temperature of the study area during the study period was 18.6°C, which very nearly approximates the average temperature of the coldest months of November, December and January. The warmest months of the year were March, April and May. The highest maximum temperature observed was 29.9°C in April.

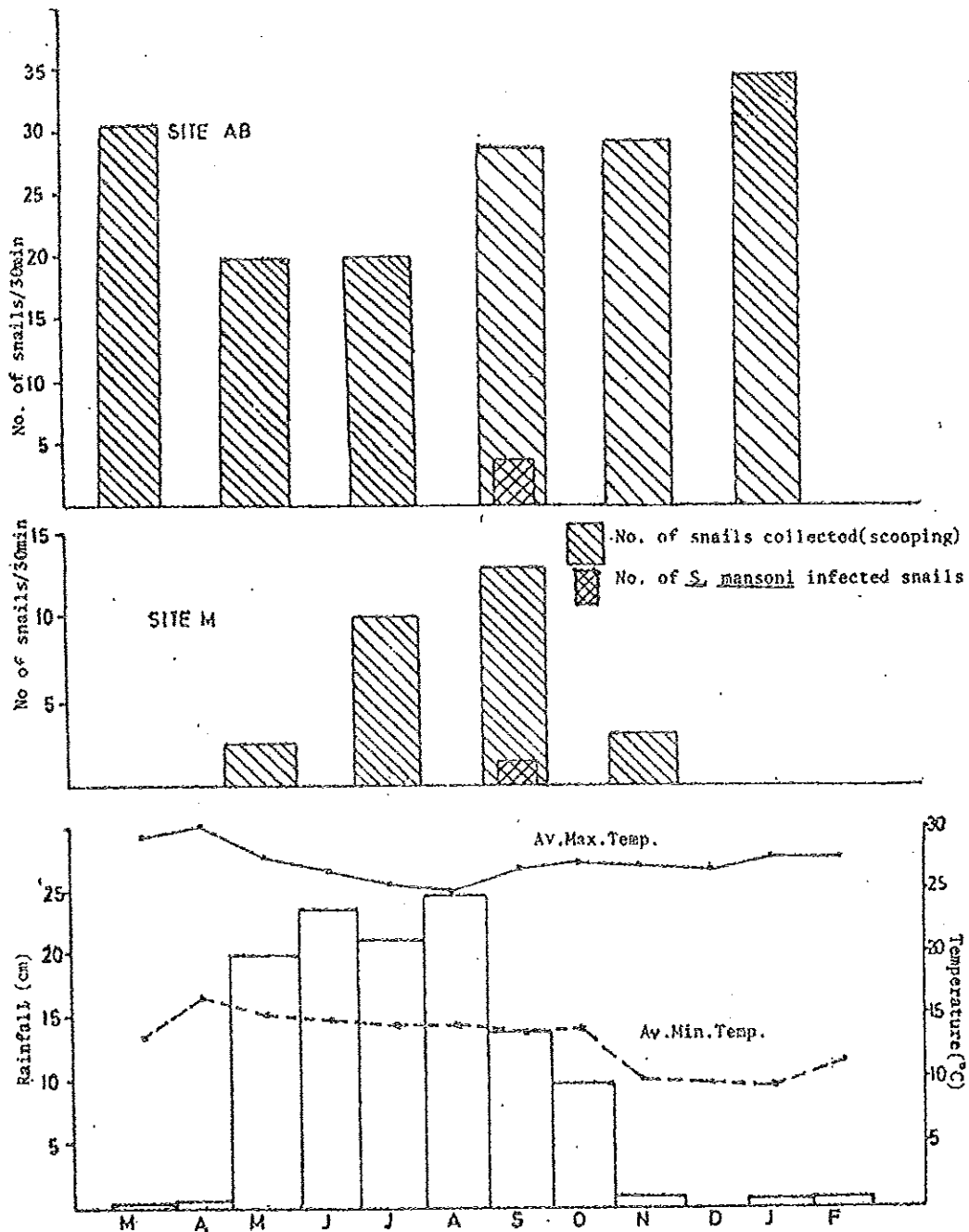

Fig.5. The bimonthly fluctuation in the number of *Biomphalaria pfeifferi* snails and associated *S. mansoni* infection in *B. pfeifferi* together with the monthly rainfall and temperature.

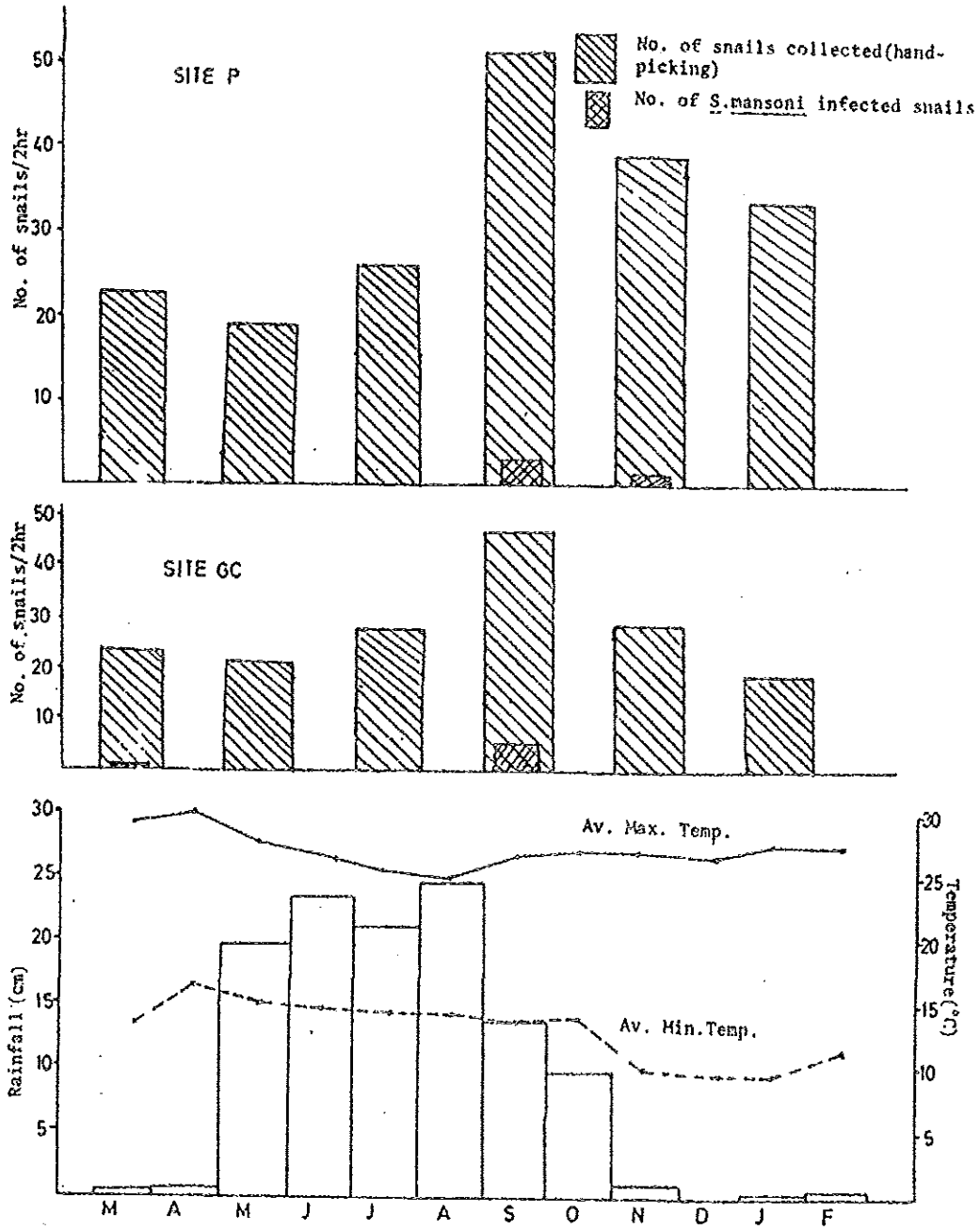

Fig. 5. Contd.

The driest months of the year included November, December, January, February, March and April in which the monthly rainfall was extremely lower than the annual average of 94.7 mm. It was in December that zero observation was made. The wettest months which received greater than the annual average rainfall were May, June, July, August, September and October. The highest amount of rainfall, about 245.4 mm was received in August (Fig.5).

Sentinel - mouse immersion

Results of sentinel mouse immersion are shown in Table 4. At sites M and P, schistosomal infection developed in mice only on one occasion (September). In mice immersed at human-water contact site GC, infection developed on two occasions (March and September) and no infection developed in mice immersed at site AB.

Water contact observations

Tables 5 and 6 show the major water contact and contaminative activities by age, sex and season recorded during two series of observations at human-water contact site AB. Table 5 indicates observations made in the rainy season while Table 6 is a record of observations made during the dry season. Water contact patterns for the rainy season were, in order of decreasing frequency, washing extremities (41.97%), water collection (34.73%), bathing (9.17%), drinking (8.03%), washing clothes(2.75%), fishing (1.61%), swimming (0.85%), defecation (contamination), (0.49%) and playing (0.39%). The patterns for the dry season were washing extremities (31.1%), water collections (28.1%), swimming (10.29%), drinking (9.49%), bathing (6.49%), washing clothes (6.24%), playing (5.29%), fishing(2.47%) and defecation (contamination) (0.59%).

Table 4. Sentinel-mouse immersion results

Month	Site							
	M		AB		P		GC	
	No. immersed	% infected	No. immersed	% infected	No. immersed	% infected	No. immersed	% infe
<u>1987</u>								
March	5	0	5(1)	0	5	0	5(2)	66.
May -	5	0	5(3)	0	5	0	5	0
July	5(1)	0	5	0	5(2)	0	5(1)	0
Sept.	5	20	5(2)	0	5(2)	33.3	5	20
Nov.	5(2)	0	5	0	5(1)	0	5(1)	0
<u>1988</u>								
Jan.	5	0	5(1)	0	5(2)	0	5	0

N.B.- Number in the brackets represent mice died during laboratory maintenance.

- Percentage infected is calculated based on the number of mice survived to the time of perfusion.

Table 5: Water contact activities by age and sex, July, 1987 (rainy season).

Particular activity	Age group in years																Total	%		
	0 - 4		5 - 9		10 - 14		15 - 19		20 - 29		30 - 39		40 - 49		50 - 59				60 +	
	M	F	M	F	M	F	M	F	M	F	M	F	M	F	M	F			M	F
Washing clothes	-	-	-	-	8	13	4	20	10	18	-	11	-	-	-	-	-	-	84	2.75
Water collection	-	-	20	28	66	164	28	202	4	342	8	152	-	46	-	-	-	-	1060	34.73
Swimming	-	-	-	-	14	-	5	-	7	-	-	-	-	-	-	-	-	-	26	0.85
Bathing	-	-	20	-	34	10	42	8	18	38	26	74	10	-	-	-	-	-	280	9.17
Washing extremities	-	-	54	38	94	114	59	114	186	178	180	106	119	29	10	-	-	-	1281	41.97
Drinking	-	-	24	10	39	30	22	30	42	10	10	18	10	-	-	-	-	-	245	8.03
Playing	-	-	4	1	2	-	5	-	-	-	-	-	-	-	-	-	-	-	12	0.39
Fishing	-	-	-	-	14	-	10	-	3	-	10	-	10	-	2	-	-	-	49	1.61
Defecation (Contamination)	-	-	-	-	-	1	3	-	4	-	-	5	-	2	-	-	-	-	15	0.49
Total	-	-	122	77	271	332	178	374	274	586	234	366	149	77	12	-	-	-	3052	

Table 6. Water - contact activities by age and sex , December, 1987 (dry season).

Particular activity	Age group in years																		Total	%
	0 - 4		5 - 9		10-14		15-19		20-29		30-39		40-49		50-59		60+			
	M	F	M	F	M	F	M	F	M	F	M	F	M	F	M	F	M	F		
Washing (Hands)	-	-	-	-	11	16	23	38	34	47	29	66	16	19	1	1	2	-	303	6.24
Water collection	1	5	97	123	107	141	7	150	17	308	5	257	5	123	-	17	-	-	1363	28.1
Swimming	3	5	100	70	108	72	88	15	37	-	1	-	1	-	-	-	-	-	500	10.29
Bathing	5	6	2	8	14	17	28	12	44	32	56	38	36	5	10	2	-	-	315	6.49
Washing extremities	12	26	70	84	168	108	203	15	247	103	95	68	105	10	34	18	8	-	1509	31.1
Drinking	1	-	40	51	52	40	57	54	61	47	30	2	13	3	-	-	-	-	461	9.49
Playing	5	5	121	32	77	5	12	-	-	-	-	-	-	-	-	-	-	-	257	5.29
Fishing	-	-	10	-	64	-	39	-	4	-	1	-	2	-	-	-	-	-	120	2.47
Defecation (Contamination)	1	-	7	2	4	-	6	1	2	3	1	1	-	1	-	-	-	-	29	0.59
Total	28	47	447	370	615	399	463	420	446	540	218	432	178	161	45	38	10	-	4857	

Table 7: Diurnal variation in frequency of water contacts
(% contacts).

Activity	6a.m-9a.m.	9a.m-12a.m	12a.m-3p.m.	3p.m-6p.m.
Washing clothes	20	30	33	17
Water collection	24.7	21.7	14.9	38.2
Swimming	5	32	43	20
Bathing	16	19	44	21
Washing extremities	28.8	16.4	31.3	23.3
Drinking	12.5	34	29.6	23.6
Playing	2.7	10.3	57.6	29.46
Fishing	16.16	13.13	40.4	30.3
Defecation (contamination)	24.14	20.7	34.5	20.7

There were relatively more contacts for washing clothes and water collection for females than for males. Bathing and swimming were predominantly performed by males. Playing in water was restricted to children. Fishing was purely the activity of males. In other activities such as washing extremities and drinking water, the frequency of contacts was similar in both sexes.

Washing clothes. Both females and males of ages more than 10 years were involved in this activity. During washing, they either stood directly inside the water and washed clothes on rocks protruding from the water or they washed on basins laid aside near the bank with water drawn in Pails. In standing, water usually reached up to their calves and while washing, hands were immersed up to the wrists. Most people used soap to wash clothes.

Water collection. This activity was mainly performed by females of all ages except the very young and elderly. Clay pitcher was the principal container for water. Few adult males were observed filling the water in large plastic barrels and carted it home for various purposes. While washing or filling the barrels, water splashed up to their elbows or their knees if they were wading in the shallow parts.

Swimming and playing. These activities were found to be more predominant among boys. Swimming involved a considerable bodily exposure to water.

Children went to the river to collect water or for the mere purpose of playing in groups, or accompanying someone who went

there to collect water or perform other activities. More male children than females enjoyed playing in the water: diving into shallow water, wadding and running in the water, splashing water over one another, and so on. When they splashed water over one another, they immersed their hands up to wrists and in running and wadding about, the legs might be exposed up to knees.

Bathing Like in swimming, there was a considerable bodily exposure to water in bathing. More males than females indulged themselves in this activity. Some people used soap when bathing.

Washing extremities. This included washing hands and feet. While washing the hands, water usually reached up to elbows. While washing feet, water may reach up to the knees.

Drinking. People usually did not go to the river for the mere purpose of drinking water. But they were observed drinking while performing other activities, for instance, washing clothes, collecting water, etc. Water collectors used their container to drink with. Those engaged in other activities used cupped hands briefly washed or drank directly from the river by kneeling or bowing down.

Fishing. Line fishing was the common method used to catch fish and it was an activity entirely performed by males. It involved minimal body exposure to water when removing hook from fish or when skinning.

Defecation. Observations of human excretion behaviour revealed that a few individuals of both sexes defecated under bushes and in tall grass just on the river bank. Very few children were seen defecating on rocks in water when swimming or bathing.

Based on the average time taken for different activities in contacting water, the patterns of activities in a decreasing order were washing clothes (59 minutes), fishing (41 minutes), swimming (28 minutes), bathing (15 minutes), playing (12 minutes), collecting water (5 minutes), washing extremities (3 minutes) and drinking (2 minutes).

Table 7 shows diurnal variations in water related activities at human water contact site AB. In activities such as washing clothes, swimming, bathing, drinking, playing and fishing, more than 50 per cent of the contacts with water took place between 9 a.m and 3 p.m., while collecting water and washing extremities involved less than 50 per cent. Before 9 a.m., collecting water (24.7%) and washing extremities (28.8%) formed the highest intensity of contacts with water. After 3 p.m., activities which had the highest intensity were collecting water (38.2%), fishing (30.3%) and playing (29.46%). Table 7 also shows that more than 50% of incidences of defecation took place around noon.

DISCUSSION

Parasitological surveys conducted in the town of Bahir Dar by investigators such as Ayele et al., (1986) revealed high infection rates for intestinal helminthiases. The present study conducted from March 1987 - February 1988 also indicated similar infection rates. This reflects poor sanitary habits which maintain the life cycle of the parasites. Particularly, the habits of defecating in the open - air, mainly observed among children, seem to be the chief contributor to the high prevalence.

The residents of the river front kebele 10 were expected to show higher prevalence of schistosomiasis mansoni infection than those of Kebele 9 by virtue of its proximity to the river Abay, scarcity of piped water supply and frequent exposure of the residents to river water. However, their prevalence was found to be equal (15%). The fact that the findings did not support the expectation might suggest that the snails and the parasite at the water contact site facing kebele 10 may have been more affected by the relatively stronger water current at that site. The river course and bank adjacent to kebele 9 had relatively denser vegetation. However, to confirm the degree of infectivity of the water, the diffused distribution of human - water contact site made malacological and transmission studies impossible at water contact site facing Kebele 9.

A correlation between age and infection prevalence and egg counts has been described by workers such as Siongok et al. (1976), Lemma et al. (1979) and Smith et al. (1979). As can be seen from Fig. 4, there is a peak in prevalence of infection and egg count in the age group 10-14 years. Nevertheless in this age group, the egg counts were not very high. Similar findings have been

reported in the community of Chiweti, northern Ethiopia (Hiatt, 1976; Polderman, 1979).

Figure 4 also shows that infection rates decline with age after forming peak in the age group 10-14 years. According to Memoranda (1974), this decrease in the prevalence of schistosomiasis in adults is attributed to reduced exposure to infection or to the development of immunological processes.

When infection rates of residents of kebele 8 are compared to that of kebeles 9 and 10, the correlation between geographical proximity of residents to the potential transmission sites and household infection rates is markedly evident. An important observation demonstrating the epidemiological significance of geographical location was the higher prevalence of infection observed in children of Sertse Dengel elementary school than in those of Dil Chibo. Dil Chibo school is situated farther away from Lake Tana than Sertse Dengel school. Interviews made with the school children at the time of stool specimen collection revealed that children of Sertse Dengel frequently went for swimming in Lake Tana while those of Dil Chibo rarely did so. Furthermore, interviews revealed that it was males from both schools, who frequently swam. Therefore, high frequency of exposure to potentially infected water bodies appears to account for higher prevalence in children of Sertse Dengel school and particularly in male children of both schools.

In a preliminary survey conducted at Sertse Dengel school, an overall prevalence of 69.3% was reported (Ayele et al., 1986). The present survey done at the same school and by using the same parasitological technique indicated a prevalence of 45%. It is not clear, however, if this difference in prevalence between the two

studies is due to reduction in transmission or to sampling bias due to lack of data.

Comparison of infection rates between sexes in the study population as a whole shows that female population had lower prevalence rates. As suggested earlier, this significant difference between them can be explained in terms of their activities. Many males swam and bathed very often whereas females did so only rarely. At Gorgora and Kunzila, the northern Shore of Lake Tana, Polderman (1974b) also attributed the difference in prevalence between sexes to the difference in exposure to the lake water.

Incidence, a measure of transmission over a given period of time, usually over 12 months (Jordan and Webbe, 1982), has been worked out for schistosomal infection in different schistosomiasis endemic countries. Farooq and Hairston (1966), working in Egypt, have found schistosomiasis haematobium incidence rates as high as 22.8% per year for the age group 0 - 6 years and schistosomiasis mansoni incidence rates of 8.5% per year. An overall four month incidence of 263 per 1000 was reported among migrants around Lake Tana (Ayele and Tiruneh, 1982). Incidence rates found in this study are presented in Table 3.

The fact that incidence calculated at the second survey (Feb., 1988) in both schools was higher than the incidence calculated at the first survey (April 1988), hints that most transmission of the disease takes place sometime between September and February.

As can be seen from Fig.5, there was little seasonal variation in temperature at the study area. However, rainfall was clearly the dominant feature of seasonal change. Thus, snail populations

as well as associated schistosomal infection appear to fluctuate according to rainfall and associated ecological changes such as water level and the density of aquatic weeds, specially Ceratophyllum demersum.

Seasonal fluctuations in the population densities of Biomphalaria, snails were studied elsewhere in Africa (McCullough, 1957 ; Cridland, 1958; Teesdale and Nelson, 1958; Gilles et al., 1975; Onabamiro 1971; Soëman, 1979). In streams around Chiwahit, northern Ethiopia, Polderman (1974 a) found permanent populations of Biomphalaria pfeifferi snails little affected by seasonal changes. Polderman (1974 b) also reported abundant mollusc fauna including numerous B. pfeifferi along the shores of Lake Tana with a dense vegetation of reeds near Wawa, a few kilometers to the east of Gorgora in October.

In this study, at human - water contact sites M, P and GC on the shores of Lake Tana, a similar pattern of seasonal fluctuation was noted in the population of Biomphalaria pfeifferi with peak density observed towards the end of the rainy season (September).

Webbe (1962) described that the density of Biomphalaria pfeifferi snails decreased due to the flooding effect and fluctuation of water level in Lake Province, Tanganyika. In Lake Volta, Ghana, the abundance of Bulinus truncatus rohlfsi coincided with the main growing season of ceratophyllum (Chu and Dawood, 1970; Chu and Vanderburg, 1976; Klumpp and Chu, 1977; Chu, 1978; Klumpp and Chu, 1980).

Similarly, peak formation in the population of snails in Lake Tana at about September could be attributed to the dense aquatic weeds,

particularly Ceratophyllum demersum or to the reduction of flooding and the flushing effects of the rains. The decline in snail density in March and January might have resulted from the falling water level in the lake. In May and July, the small number of snails collected might be attributed to the rising lake level and corresponding negative changes in habitat.

The fact that abundant Biomphalaria pfeifferi snails were found during thick growth of Ceratophyllum demersum may give some insight as regards the possibility of implementing weed removal as a control strategy. However, this presupposes further ecological studies.

At site AB on the River Abay, snails appeared to increase in numbers from the end of the rainy season to the middle of the dry season (January). During this time of the year, water current appears to be sufficiently slow to allow for the establishment of snail populations. Such a pattern of change in snail population was also reported by Sodeman (1979) and Lemma et al. (1979). These authors attributed small number of snails recovered during the rainy season to the flushing effect of water velocity.

Difference in population build up of snails in Lake Tana and the River Abay in the dry season appears to be due to the difference in density of aquatic weeds of the two habitats. In the dry season, the course and shallow banks of the River Abay had relatively denser vegetation while the rocky shores of Lake Tana had sparse or no vegetation at all for a few months of the year. In describing the importance of aquatic weeds to snails, Lazo et al. (1966) have observed that weeds obstruct the flow of water

and provide an excellent breeding ground for snails. So at the shores of Lake Tana where there was sparse or no vegetation during the dry season, desiccation of habitats and death of snails was more apparent than at sites on the River Abay.

Besides fluctuation in the density of snail population, associated seasonal fluctuations in cercarial or snail infection rates have also been reported from various schistosomiasis endemic countries. Among these are Nigeria (Gilles et al., 1965), Rhodesia (Shiff et al., (1979) and Liberia (Sodeman, 1979). Similar fluctuations in snail infection rates were noted in this study.

Except at site AB on the Bank of the River Abay, the time of peak cercarial infection coincided with the time of collection of relatively large number of snails. Such overlapping of high cercarial infection rate and peak snail population was reported for Lake Province, Tanganyika (Webbe, 1962). Although the collection of infected snails at site GC in March and P in November suggest little intermittent transmission of schistosomiasis in place and time, the general pattern of transmission in Lake Tana appears to be high as the water level started to recede around September. Thus, it appears that there is a close correlation between snail density, cercarial transmission and the density of Ceratophyllum wecos. The finding that corresponds with this transmission pattern is that of S. haematobium in Lake Volta (Klumpp and Chu, 1977; Chu, 1978).

In the case of cercarial transmission patterns at human water contact on the River Abay, care must be taken in interpreting the data gathered from a single water contact site. Because, the

results from this single site might or might not be typical of the whole situation of the River Abay in Bahir Dar.

The fact that relatively large number of infected snails were collected towards the end of the rainy season when mature snails started to appear in the habitat could be due to the pollution of snail habitats from the wash-in of infected faeces by flood. The relatively small number of infected snails collected, in the dry season further suggests the importance of the wash-in of faeces as the chief source of snail infection. The absence of infected snails during the early rainy season (May - July) might be attributed to the effect of flooding, high water velocity or the effect of heavy rains either on the snails or miracidia and prepatency of S. mansoni infection in Biomphalaria pfeifferi. During this early rainy season, the snail population was composed of a larger proportion of young snails. This could also be the reason for the absence of infected snails since high infection rate is typical of mature snails (Webbe, 1962).

Cercarial infection rate or number of infected snails (Fig.5) showed no correlation with the results of sentinel mouse exposure (Table 4). This discrepancy cannot be explained with the available data although water velocity may have been a factor at AB Site.

Discussing the lack of correlation between cercarial infection rate and the results of mouse exposure, Sato et al., (1985) stated that the population and distribution of cercariae emanated from the infected snails in the natural water vary with factors such as water current. Furthermore, Jordan et al. (1980) pointed out that water velocity may affect cercarial infectivity by altering time available for penetration.

Like the various water related activities classified in Egypt (Farooq and Mallah, 1966) and Ethiopia (Kloos and Lemma, 1980), water related activities identified in this study could also be broken down as follows: contaminative, exposure and mixed (both contaminative and exposure). Contaminative activity included defecation, exposure included contacts with potentially infective water such as water collection, washing extremities, drinking, playing and fishing, while mixed activities were washing clothes, swimming and bathing.

Most females were found to be engaged in activities of shorter duration involving minimal body exposure than males. Males mostly had exposure of longer duration which involved maximal body exposure. This difference of activities between sexes might have accounted for the higher infection rates in males (Tables 1 and 2).

By virtue of having a longer duration and being frequented when peak cercarial shedding time is expected (9 a.m - 3 p.m), washing clothes seem to involve the maximal risk of exposure to infection. However, the use of detergents (Jordan et al., 1980) and the fact that only limited parts of the body come in contact with the water appear to reduce the risk of infection while washing.

Bathing and swimming could carry an increased risk of infection because they involve total bodily immersion.

Activities such as water collection, washing extremities, drinking and fishing were probably of less importance in the transmission of schistosomiasis. Because, they involved exposure of short duration and bodily exposure was minimal.

Defecation (contamination) constituted the least proportion of the observed activities. However, since most of the observed contaminative activities took place, directly on the edge of the water under bushes or in tall grass, the pollution of snail habitats was very likely. This was common in the rainy season when vegetation cover is higher.

Table 7 presents diurnal variations in human-water related activities while a comparison of tables 5 and 6 reveals seasonal variations. These observations agree with that made in Tensae Berhan (Kloos and Lemma, 1980) and in St.Lucia (Dalton,1976). Diurnal variations, might depend on school shift, market hours or weather. Seasonal variations in water contact activities appear to depend on weather, availability of rainwater during the rainy season or the rising of water level. Higher water contact activities recorded in the dry season (Table 6) may suggest that warm weather induces water contact activities. As interviews made at the time of stool specimen collection indicated, rainwater caught from the roof of a house is used for several purposes during the rainy season thereby minimizing the frequency for household contacts. The rising of water level was avoided by many, especially children, as suggested by small number of contacts recorded in the rainy season (Table 5).

In Egypt, Farooq and Mallah (1966) found that peak seasonal and diurnal cycles of infectivity of waters coincide with the frequency and duration of water contact activities. Rowan(1958) observed that cercarial densities reach their peak during the middle of the day. In some streams in northern Ethiopia, Polderman (1974b) reported that the time of peak cercarial density is

11:00 a.m. to 3 p.m. Observations made in the course of this study revealed that some water contact activities had the highest intensity between 9 a.m. and 3 p.m. (Table 7) when cercarial density was expected to be high in the natural water. Furthermore, from water contact observations carried out in the dry season (Table 6), it can be suggested that the period of increasing water contact activities induced by warm weather coincided with the period when high infectivity of the water was noted (at about September). Thus, it was possible that majority of the cases acquired infection from having contact with water teeming with cercariae as a result of diurnal and seasonal variations in their water contact activities.

Attempts have not been made to correlate parasitological data and water contact studies on the same individuals to assess the risk of infection from different water contact activities. Nevertheless, Jordan and Webbe (1982) have pointed out that infection depends on factors such as contact duration, degree of bodily exposure and time of day. Hence, taking these factors into account, swimming, bathing and playing appear to increase the likelihood of schistosomiasis mansoni transmission in this endemic focus.

CONCLUSION

Differences in infection rates among kebeles and between schools points to the importance of geographical location of a population with respect to the potentially infective water body. Incidence of infection in Dil Chibo and Sertse Dengel schools may also be influenced by distance to the water although this needs further study.

Infection rates between sexes seem to differ due to differences in water contact behaviour of the two sexes.

Based on the extent of body exposure, duration of contact with water and the time of the day, it can be concluded that playing in water, swimming and bathing play important role in the transmission of schistosomiasis.

Snail population dynamics and associated schistosomal infection appear to vary according to rainfall and associated ecological factors such as water level fluctuation and the density of aquatic weeds, specially Ceratophyllum demersum.

As suggested by mice exposure results, malacological findings and incidence studies, the peak of transmission period of schistosomiasis in Lake Tana appears to take place towards the end and after rainy season when Biomphalaria pfeifferi snails are abundant. However, this needs to be confirmed by further malacological and transmission studies. Little intermittent transmission throughout they year is also likely.

Since data on snail population and infection were gathered from only a single essential human-water contact point on the River Abay at Bahir Dar, care should be taken in interpreting the results.

Finally, to recommend control strategy which is cost-effective and feasible to this endemic focus, monthly surveys over a period of at least one year should be made --large samples of snails from several sites should be screened to accurately determine the seasonality in snail population dynamics and schistosomal infections in the vector snails. It would also seem to be more effectual if this should be corroborated by monthly sentinel-mouse exposure studies. However, the following can at least be suggested based on the present study to reduce transmission of the disease: chemotherapy of infected individuals, focal mollusciciding towards the end of the rainy season when infected Biomphalaria pfeifferi snails appear to occur in abundance, to encourage the building and use of piped water supply and latrines, and to limit those human-water contact activities which have high intensity at around noon to early morning or late afternoon when the infectivity of the natural water is expected to be low. These last 3 measures could only be implemented through health education.

REFERENCES

- Ali, A., Lo.C.T., and Ayele, T. (1986). Schistosoma haematobium in Western Ethiopia. Ethiop. Med. J., 24(2), 73 - 78.
- Appleton, C.C. (1978), Review of literature on abiotic factors influencing the distribution and life cycles of bilharziasis intermediate host snails. Malacol. Rev., 11, 1 - 26.
- Ayad, N. (1956). Bilharziasis survey in British Somaliland, Eritrea, Ethiopia, Somalia, the Sudan and Yemen, Bull. Wld. Hlth Org., 14(1), 117.
- Ayele, T. (1982). The Distribution of schistosomiasis in Ethiopia: results of 1978 - 1982 survey. In: Schistosomiasis in Ethiopia. Proceedings of a Symposium on Human Schistosomiasis in Ethiopia: pp 1-8, Ayele, T., and Lo.C.T.(Eds). Institute of Pathobiology, Addis Ababa University.
- Ayele, T., Abebe, F., Lo.C.T., and Tedla, S. (1986). A preliminary study of schistosomiasis mansoni in Bahir Lar. Abstract in Ethiop. Med. J., 24(1), 43.
- Ayele, T., and Tiruneh, M. (1982). The incidence of schistosomiasis mansoni in new comers around Lake Tana. In: Schistosomiasis in Ethiopia. Proceedings of a symposium on Human Schistosomiasis in Ethiopia: pp. 29 - 31. Ayele, T., and Lo.C.T.(Eds). Institute of Pathobiology, Addis Ababa University.
- Barbosa, F.S.(1962). Aspects of the ecology of the intermediate hosts of S. mansoni interfering with the transmission of bilharziasis in North-eastern Brazil: In: Ciba Foundation Symposium on Bilharziasis. 23-35. Wolstenholme, G.E.W., and OConnor, M. (Ed.). Little, Brown and Company, Boston.
- Berrie, A.D.(1970). Snail Problems in African Schistosomiasis. In: Advances in Parasitology, Vol. 8. Academic Press, London, New York.
- Birrie, H. (1986). Survey of Schistosomiasis mansoni in the Borkena river basin, Ethiopia, Ethiop. Med. J., 24(4), 150.

- Brown, D.S. (1980). Freshwater snails of Africa and Their Medical Importance. Taylor and Francis, London.
- Buck, A.A., Spruyt, D.J., Wade, M.K., Dressa, A., and Feyssa, E. (1965). Schistosomiasis in AGwa: A report on epidemiological pilot study. Ethiop. Med. J., 3, 93 - 106.
- Chandler, A.C. (1956). Introduction to Parasitology. Chap. 13, John Wiley and Sons., New York.
- Chang, W.P. (1961). Report on bilharziasis in Gorgora, north shore of Lake Tana, Ethiopia. Gondar Health Series, Technical Report No.1, 4 - 7.
- Cheesbrough, M. (1987). Medical laboratory Manual for Tropical countries (2nd ed.) Vol.1. Tropical Health Technology and Butterworths, London.
- Chernin, E., and Antolics, V.M. (1973). Laboratory transmission of S. mansoni to snails via fomites. J. Parasit., 59, 589-591.
- Christensen, N.O. (1980). Echinostoma revolutum: labeling of miracidia with radioselenium in vivo and assay for host finding. Exp. Parasit., 50, 67 - 73.
- Christensen, N.O., Frandsen, F., and Svenningsen, A.E. (1987), eds. Danish Bilharziasis Laboratory Biennial Report, 1985 and 1986. Charlottenluna, Denmark.
- Christie, J.L., and Upatham, E.S. (1977). Control of S. mansoni transmission by chemotherapy in St. Lucia. II. Biological results. Am. J. Trop. Med. Hyg., 26, 894-898.
- Chu, K.Y. (1978). Trial of ecological and Chemical measures for the control of S. haematobium transmission in a Volta Lake Village. Bull. Wld Hlth Org., 56, 313 - 322.
- Chu, K.Y., and Dawood, I.k. (1970). Cercarial transmission seasons of S. mansoni in the Nile delta area. Bull. Wld Hlth Org., 49, 575.

- Chu, K.Y., Massouh, J., and Sabbaghian, H. (1966). Host parasite relationship of Bulinus truncatus and S. haematobium in Iran. 3. Effect of Water temperature on the ability of miracidia to infect snails. Bull. Wld Hlth Org., 34, 131-133.
- Chu, K.Y., and Vanderburg, J.A. (1976). Techniques for estimating densities of Bulinus truncatus rohlfsi and its horizontal distribution in Volta Lake, Ghana. Bull. Wld Hlth Org., 54, 411 - 420.
- Crieland, C.C. (1958). Ecological factors affecting the numbers of snails in a permanent stream. Ibid 61, 16.
- Dalton, P.R. (1976). A Sociological approach to the control of Schistosoma mansoni in St. Lucia. Bull. Wld Hlth Org., 54(5), 587-595
- Dalton, P.R., and Fole, D. (1978), water contact patterns in relation to S. haematobium infection. Bull. Wld Hlth Org., 56, 417.
- Dazo, B.C., Hairston, N.G., and Dawood, I.K. (1966). The ecology of Bulinus truncatus and Biomphalaria alexandrina and its implications for the control of bilharziasis in the Egypt 49 project areas. Bull. Wld Hlth Org., 35(3), 339-356.
- Deschiens, R., and Lelas, A.E. (1969). L'extension géographique de la bilharziose a schistosoma intercalatum en Afrique tropicale. Trans. Roy. Soc. Trop. Med. Hyg., 63(4 suppl.),
- De Sole, G., Lemma, A., Mazengia, B (1978). Schistosoma haematobium in the Wabi Shebelle Valley of Ethiopia. Am. J. Trop. Med. Hyg., 27, 928 - 930.
- DeWitt, W.H. (1955). Influence of temperature on Penetration of Snail hosts by S. mansoni miracidia. Exp. Parasit., 4, 271 - 276.
- Duncan, J., and Lemma, A. (1976). Investigations into the control of schistosomiasis at the HVA Wonji - Shoa Sugar estates in Ethiopia. 1. Intiation of the project. Ethiop. Med. J., 14, 3.

- Duval, R.H., and DeWitt, W.B. (1967). An improved perfusion technique for recovering adult schistosomes from laboratory animals. Am. J. Trop. Med. Hyg., 16(4), 483-487.
- Eshete, H. (1987). Schistosoma mansoni infections in the Anuak ethnic group, Western Ethiopia. Ethiop. Med. J., 25(4), 195 - 198.
- Farooq, M., and Hairston, N.G. (1966). The epidemiology of S. haematobium and S. mansoni infection in the Egypt - 49 project area: 4. Measurement of the incidence of bilharziasis. Bull. Wld Hlth Org., 33(3), 331 - 338.
- Farooq, M., and Mallah, M.B. (1966). The behavioural pattern of social and religious water contact activities in Egypt - 49 Bilharziasis Project Area. Bull. Wld Hlth Org., 35, 377.
- Farooq, M., Nielsen, J., Samoon, S.A., Mallah, M.B., and Allam A.A.(1966). The epidemiology of S. haematobium and S. mansoni infection in Egypt-49 project area 2. Prevalence of bilharziasis in relation to personal attributes and habits. Bull. Wld Hlth Org., 35(3), 293 - 318.
- Fenwick, A., Cheesmond, A.k., Kardoman, M., Amin M.A., and Manjing, B.K. (1982). Schistosomiasis among labouring communities in the Gezira irrigated area, Sudan. J. Trop. Med. Hyg., 85(1), 3 - 11.
- Foster, R. (1964). The effect of temperature on the development of S. mansoni Sambon 1907 in the intermediate host. J.Trop Med. Hyg., 67, 288 - 292.
- Fuller, G.K., Lemma, A., and Haile, T. (1979). Schistosomiasis in Omo National Park of Southwest Ethiopia. Am. J. Trop. Med. Hyg., 28(3), 526 - 530.
- Gilles, H.M., Lucas, A., Adeniyi - Jones, C., Linder R., Anand S.V., Brabant, H., Cockshott, W.p., Cowper, S.G., Muler R.l., Nira, P.R., and Wilson, A.M.M. (1965). S.haematobium infection in Nigeria. II. Infection at a primary school in Ibadan. Ann. Trop. Med. Parasit., 59, 441 - 450.

- Goll, P.H., Lemma, A., Duncan, J., and Mazengia, G. (1983). Control of schistosomiasis in Aowa, Ethiopia using the plant molluscicide endod (Phytolacca dodecandra). J. Tropenmed. Parasit., 34, 177-183.
- Gundersen, G.S., and Birrie, H. (1982). Schistosomiasis mansoni at different altitudes in the Blue Nile Valley, Mendi district, Wollega region, Ethiopia. In : Schistosomiasis in Ethiopia. Proceedings of a Symposium on Human Schistosomiasis in Ethiopia: pp. 15-18. Ayele T., and Lo., C.T. (Eds). Institute of Pathobiology, Addis Ababa University.
- Haile-Meskal, F., Abdulahi, Y., and Eshete, H. (1981). Disruption of bilharzia transmission in Kortume flood plain of the Awash Valley, Ethiopia. Ethiop. Med. J., 19,117-122.
- Hairston, N.G. (1973). The dynamics of transmission. In: Epidemiology and Control of Schistosomiasis (Bilharziasis): pp. 250 - 333. Ansari, M (Ed.), Karger, London.
- Halawani, A. (1959). Report on schistosomiasis. Proceedings of 6th International Congress on Tropical Medicine and Malaria 2, 9.
- Husting, E.L. (1965). A Probable method of transmission of S. mansoni. Centr. Afr. J. Med., 11, 330 - 331.
- Hiatt, R.A. (1976). Morbidity from S. mansoni infections: an epidemiological study based on quantitative analysis of egg excretion in two highland Ethiopian villages. Am.J. Trop. Med. Hyg., 25, 808.
- Ingall, J.E. (1949). The molluscan intermediate host and schistosomiasis japonicum. I. observation on the condition governing the hatching of eggs of S. japonicum. J. Parasit., 35, 147 - 151.

- Institute of Pathobiology (1980). Progress Report No.2 Expanded Programme of applied research and training towards prevention and control of schistosomiasis in Ethiopia. Pathobiology Research Institute, Addis Ababa.
- Jordan, P., Christie, J.D., and Unrau, G.D. (1980). Schistosomiasis transmission with particular reference to possible ecological and biological methods of control. Acta Topica 37,95 - 135.
- Jordan, P. and Webbe, G. (1982). Schistosomiasis Epidemiology, Treatment and Control. 1st ed., William Heineman Medical Books Ltd., London.
- Kloos, H., and Lemma, A. (1980). The epidemiology of S. mansoni. infection in Tensae Berhan: Human water contact patterns, Ethiop. Med. J., 18, 91 - 99.
- Kloos, H., Lemma, A., and De Sole, G. (1978). S. mansoni distribution in Ethiopia: A study in medical geography. Ann. Trop. Med. Parasit., 72, 461 - 470.
- Klumpp, R.K., and Chu, K.Y. (1977). Ecological studies of Bulinus rohlfsi, the intermediate host of S. haematobium in the Volta Lake. Bull. Wld. Hlth Org., 55, 715 - 730.
- Klumpp, R.K., and Chu, K.Y. (1980). Importance of Aquatic weed Ceratophyllum to transmission of S. haematobium in the Volta Lake . Bull. Wld. Hlth Org., 55, 715 -798.
- Kubasta, M. (1964). Schistosomiasis mansoni in the Harar Province. Ethiop. Med. J., 2, 260.
- Lemma, A. (1965). Schistosomiasis in Adwa: A report on an ecological pilot study. Ethiop. Med. J., 3,84.
- Lemma, A. (1969). Bilharziasis in the Awash Valley. I. An epidemiological study with special emphasis on its possible future economic and public health importance. Ethiop. Med. J., 7, 147 - 176.

- Lemma, A., De Sèle, G., Polderman, A.M., Mazengia, B., Reda, A., and Kloos, H. (1979). The epidemiology of S. mansoni infection in Tensae Berhan, Ethiopia: Prevalence of schistosomiasis. Ethiop. Med. J., 17 63 - 74.
- Lo. C.T. (1970). Snail intermediate host of S. haematobium in Ethiopia. Proc. Organization of African Unity Symposium on Schistosomiasis, pp. 85 - 88. OAU Health Bureau Publ., No.1, Addis Ababa.
- Lo.C.T., Flemings, M.B., Lemma, A. (1973). Schistosomiasis in Harar, Alemaya, and the Damota Valley, Ethiopia. Ethiop. Med. J., 11, 271-278.
- Lo.C.T., Kloos, H., and Birrie, H. (1988) Schistosomiasis. In: The Ecology of Health and Disease. Zein Ahmed Zein, and Kloos, H. (Eds). Ministry of Health, Addis Ababa.
- Malek, E.A. (1958). Factors conditioning the habitat of bilharziasis intermediate hosts of the family planorbidae. Bull. Wld Hlth Org., 18, 785 - 818.
- Malek, E.A. (1962). Bilharziasis Control in Pump schemes near Khartoum, Sudan, and evaluation of chemical and mechanical barriers. Bull. Wld. Hlth Org., 27, 41 - 58.
- Manuahl - Barth, G. (1958). Intermediate Hosts of Schistosoma: African Biomphalaria and Bulinus. WHO Monograph series No.37., WHO, Geneva.
- Mausner, J.S., and Kramer, S. (1985). Epidemiology: an introductory text, 2nd ed. Saunders, Philadelphia.
- Mc Connell, E., and Armstrong, J.C. (1976). Intestinal parasitism in fifty communities on the central plateau of Ethiopia. Ethiop. Med. J., 14, 159 - 168.

- McCullough, F.S. (1957). The seasonal density of populations of Eulinus (Physopsis) globosus and E. forskalii in natural habitats in Ghana. Ann. Trop. Med. Parasit., 51, 235 - 248.
- Memoranda (1974). Immunology of schistosomiasis. Bull. WHO Hlth Org., 51, 553 - 595.
- Ministry of Health (1987). Basic Physical and Social Infrastructure of Bahir Dar. Ministry of Health, Gojjam Regional Branch.
- Mott, K.E. (1984). Schistosomiasis: new goals. World Health (December, 1984), pp. 3 - 4 .
- Onabamiro, S.D. (1971). Studies on schistosomiasis in Sierra Leone - I. Ann. Trop. Med. Parasit., 65 , 497 - 504.
- Peters, P.A. El Alomy, M., Warren, K.S., and Mahmoud A.A.F.(1980). Quick Kato smear for field quantification of S. mansoni eggs. Am. J. Trop. Med. Hyg., 29, 217 - 219.
- Pimentel, D., Gerhardt, C., Williams, E.R., White, P.C.Jr., and Ferguson, F.F. (1961). Aspects of Schistosomal endemicity in three Puerto Rican Watersheds, Am. J. Trop. Med. Hyg., 10, 523-529.
- Polderman, A.M. (1974 a). Schistosomiasis in Begemder Province, Ethiopia. Final Report on a Research Project, Leiden Netherlands.
- Polderman, A.M. (1974 b). Intestinal schistosomiasis north and west of Lake Tana Ethiopia. Trop. Geogr. Med., 26, 170 - 177.
- Polderman, A.M. (1979). Transmission dynamics of endemic schistosomiasis. Trop. Geogr. Med., 31, 465 - 475.
- Pra, S.K., and James, C. (1977). The influence of physical factors on the survival and infectivity of miracidia of S. mansoni and S. haematobium. I. Effect of temperature and ultra - violet light. J. Helminth., 51, 73 - 85.

- Prentice, M.A., Panesar, T.S., and Coles, G.C. (1970).
Transmission of S. mansoni in a large body of water.
Ann. Trop. Med. Parasit., 64, 339 - 348.
- Purnell, R.E. (1966). Host-parasite relationships in
schistosomiasis. I. The effect of temperature on the
infection of Biomphalaria sudanica tangaanyicensis with
S. mansoni cercariae. Ann. Trop. Med. Parasit., 60, 90-93.
- Ritchie, L.S., Radke, M.G., and Ferguson, F.F. (1962). Population
Dynamics of Australorbis glabratus in Puerto Rico. Bull.
Wld Hlth Org., 27, 171 - 178.
- Rowan, W.B. (1964). Sewage treatment and schistosome eggs.
Am. J. Trop. Med. Hyg., 13, 572 - 576.
- Russel, J.E.L. (1958). Final report pilot mobile health team
Ethiopia. WHO/EM/PHA/ 62, Ethiopia 13, 36 pp.
- Sato, K., Noga, S., Miguwe, D.K., Ziro, G.N. and Muhoho, N.D.
(1985). Epidemiological studies on S. haematobium infection
in coastal area, Kenya; cercarial density at water contact
points and identification of species of cercariae. Trop.
Med., 27(4), 197 - 202.
- Shattock, M.S., Fraster, R. J. and Garnett, P.A. (1965).
Seasonal variations of cercarial output from Biomphalaria
pfeifferi and Bulinus (Physopsis) blokosus in Southern
Rhodesia. Bull., Wld Hlth Org., 33, 276 - 278.
- Shiff, C.G., Coutts, W.C., Yiannakis, C., and Holmes, R. W. (1979).
Seasonal patterns in the transmission of S. haematobium in
Rhodesia, and its control by winter application of
molluscicide, Trans., Roy. Soc. Trop. Med. Hyg., 73(4),
375 - 381.
- Shiff, C.J. Evans, A., Yinnakis, C., and Eardley, M. (1975).
Seasonal influence on the production of S. haematobium
and S. mansoni cercariae in Rhodesia. Int. J. Parasit.,
5, 119 - 123.

- Siongok, T.A., Mahmoud, A.A.P., Ouma, J.H., Warren, K.S., Muller, A.S., Honda, A.K., and Houser, R.B. (1976). Morbidity in schistosomiasis mansoni in relation to intensity of infection: Study of a community in Machakos, Kenya, Am. J. Trop. Med. Hyg., 25, 273 - 284.
- Smith, J.H., Warren, K.S., and Mahamoud, A.A.P. (1971). Morbidity in schistosomiasis mansoni in relation to intensity of infection: Study of a community in Kisumu, Kenya, Am. J. Trop. Med. Hyg., 28, 220 - 229.
- Snedecor, G.W., and Cochran, W.G. (1967). Statistical Methods, 6th ed. The Iowa State University Press., Iowa, U.S.A.
- Sodeman, Jr. W.A. (1979). A longitudinal study of schistosome vector snail populations in Liberia. Am. J. Trop. Med. Hyg., 28(3), 531 - 538.
- Southwood, T.R.E. (1977) Habitat, the temple of ecological strategies? J. Anim. Ecol., 46, 337 - 365.
- Stirewalt, M.A. (1954). Effect of snail maintenance temperatures on development of S. mansoni, Exp. Parasit., 3, 604 - 516.
- Sturrock, R.F. (1986). Detection of schistosome transmission sites: snail collection to detect schistosome transmission sites. Parasitol. Today 2(3), 59 - 61.
- Teesdale, C., and Nelson, G.S. (1958). Recent work on Schistosomes and snails in Kenya, E. Afr. Med. J., 35, 427-438.
- Teklehaimanot, R. and Goll, P.H. (1978). Investigations into the control of schistosomiasis at the HVA Wonji-Shoa Sufar Estates in Ethiopia. Ethiop. Med. J., 16, 115.
- Uptham, E.S. (1972). Studies on the hatching of S. mansoni eggs in standing water and running water habits in St. Lucia, West Indies. S. E. Asia. J. Trop. Med. Publ. Hlth., 3, 600 - 604.

- Urtahan, E.S. (1973). The effect of low temperature on the penetration and development of St. Lucian S. mansoni miracidia in local Biomphalaria glabrata. S. E. Asia, J. Trop. Med. Publ. Hlth., 4, 367 - 370.
- Vogel, M., Bruckner, D., and Bruce, J. I. (1972). S. mekongi Sp. n. from man and animals, compared with four geographic strains of S. japonicum. J. parasit., 64(4) 577 - 584.
- Water Supply and Sewerage Authority (1982). Feasibility Study for water supply. Associated Engineering Services Ltd., Vancouver, British Columbia.
- Watson, J.M. (1958). Proceedings of the Sixth International Congress on Tropical Medicine and Malaria 2, 203.
- Webbe, G. (1960). Observations on the seasonal fluctuation of snail population densities in the northern Province of Tanganyika. Ann. Trop. Med. Parasit., 54, 54.
- Webbe, G. (1962). The transmission of S. haematobium in an area of Lake Province, Tanganyika. Bull. Wld Hlth Org., 29, 59-85.
- Webbe, G. (1964). Biology of intermediate hosts of schistosomiasis, with particular reference to control of schistosomiasis. Ann. Trop. Med. Parasit., 58, 228 - 233.
- Webbe, G. (1965). Transmission of bilharziasis. Bull. Wld Hlth Org., 33, 155 - 162.
- Webbe, G. (1966). The effect of water velocities on the infection of animals exposed to S. mansoni cercariae. Ann. Trop. Med. Parasit., 60, 78 - 89.
- Webbe, G., (1982). The intermediate host and host parasite relationships. In: Schistosomiasis Epidemiology, Treatment and Control. Jordan, P., and Webbe, G. (Eds). William Heinemann Medical Books Ltd., London.
- Webbe, G., and Msagani, A.S. (1958). Observations on three species of Bulinus on the east coast of Africa. Ann. Trop. Med. Parasit., 52, 302 - 314.

Wolfe, M.S. (1974). Schistosoma intercalatum infection in an American family. Am. J. Trop. Med. Hyg., 23(1), 45 - 50.

World Health Organization (1957). Group on the Ecology of Intermediate Snail Hosts of Bilharziasis. WHO. Tech. Rep. Ser. No. 120.

World Health Organization (1980). Epidemiology and Control of Schistosomiasis, WHO. Tech. Rep. Ser., No.643.

World Health Organization (1985). The control of Schistosomiasis WHO. Tech. Rep. Ser., No, 728.

Wright, C.A., Southgate, U.R., and Knowles, R.G. (1972). What is S. intercalatum Fisher 1934? Trans. Roy. Soc. Trop. Med. Hyg., 66, 28.

Wright W.H. (1973), Geographic distribution of schistosomes and their intermediate hosts. In: Epidemiology and Control of Schistosomiasis (Bilharziasis): pp. 32 - 250. Ansari, M. (Ed.).

Yiman, M. (1964). Schistosomiasis at Wonji. Ethiop. Med. J., 2, 250.

Zaphiropoulos, M. (1963). Preliminary observations on bilharziasis in Lake Tana, Ethiopia, and on the treatment of S. mansoni infections with Miracil - D. Gondar Health Series, No.7, 27 - 33.

APPENDIX III

Water Contact Form II

Activity _____

Observer _____

Site _____

Date _____

Activity	6a.m.-9a.m.	9a.m.-12a.m.	12a.m.-3p.m.	3p.m.-6.p.m.	Total
Washing clothes					
Swimming					
Bathing					
Washing extremities					
Drinking					
Playing					
Fishing					
Defecation					
Total					